

SECTION IP
INSTRUMENT PANEL

A
B
C
D
E
F
G
H
I
IP
K
L
M
N
O
P

CONTENTS

PRECAUTION	2	CLUSTER LID C	16
PRECAUTIONS	2	Exploded View	16
Precaution for Supplemental Restraint System (SRS) "AIR BAG" and "SEAT BELT PRE-TENSIONER"	2	Removal and Installation	16
Precaution Necessary for Steering Wheel Rotation After Battery Disconnect	2	INSTRUMENT LOWER PANEL RH AND GLOVE BOX	17
PREPARATION	4	Exploded View	17
PREPARATION	4	Removal and Installation	17
Special Service Tool	4	INSTRUMENT UPPER PANEL RH	18
Commercial Service Tool	4	Exploded View	18
SYMPTOM DIAGNOSIS	6	Removal and Installation	18
SQUEAK AND RATTLE TROUBLE DIAGNOSES	6	A/T FINISHER	19
Work Flow	6	Removal and Installation	19
Generic Squeak and Rattle Troubleshooting	8	FRONT CENTER CONSOLE	20
Diagnostic Worksheet	10	Exploded View	20
ON-VEHICLE REPAIR	12	Removal and Installation	20
INSTRUMENT PANEL ASSEMBLY	12	REAR CENTER CONSOLE	21
Exploded View	12	Removal and Installation	21
Removal and Installation	13	DISASSEMBLY AND ASSEMBLY	22
CLUSTER LID A	15	FRONT CENTER CONSOLE	22
Exploded View	15	Exploded View	22
Removal and Installation	15	Disassembly and Assembly	23
		REAR CENTER CONSOLE	24
		Exploded View	24
		Disassembly and Assembly	25

PRECAUTIONS

< PRECAUTION >

PRECAUTION

PRECAUTIONS

Precaution for Supplemental Restraint System (SRS) "AIR BAG" and "SEAT BELT PRE-TENSIONER"

INFOID:000000005867479

The Supplemental Restraint System such as "AIR BAG" and "SEAT BELT PRE-TENSIONER", used along with a front seat belt, helps to reduce the risk or severity of injury to the driver and front passenger for certain types of collision. This system includes seat belt switch inputs and dual stage front air bag modules. The SRS system uses the seat belt switches to determine the front air bag deployment, and may only deploy one front air bag, depending on the severity of a collision and whether the front occupants are belted or unbelted. Information necessary to service the system safely is included in the SR and SB section of this Service Manual.

WARNING:

- To avoid rendering the SRS inoperative, which could increase the risk of personal injury or death in the event of a collision which would result in air bag inflation, all maintenance must be performed by an authorized NISSAN/INFINITI dealer.
- Improper maintenance, including incorrect removal and installation of the SRS, can lead to personal injury caused by unintentional activation of the system. For removal of Spiral Cable and Air Bag Module, see the SR section.
- Do not use electrical test equipment on any circuit related to the SRS unless instructed to in this Service Manual. SRS wiring harnesses can be identified by yellow and/or orange harnesses or harness connectors.

PRECAUTIONS WHEN USING POWER TOOLS (AIR OR ELECTRIC) AND HAMMERS

WARNING:

- When working near the Airbag Diagnosis Sensor Unit or other Airbag System sensors with the Ignition ON or engine running, DO NOT use air or electric power tools or strike near the sensor(s) with a hammer. Heavy vibration could activate the sensor(s) and deploy the air bag(s), possibly causing serious injury.
- When using air or electric power tools or hammers, always switch the Ignition OFF, disconnect the battery, and wait at least 3 minutes before performing any service.

Precaution Necessary for Steering Wheel Rotation After Battery Disconnect

INFOID:000000005867480

NOTE:

- This Procedure is applied only to models with Intelligent Key system and NATS (NISSAN ANTI-THEFT SYSTEM).
- Remove and install all control units after disconnecting both battery cables with the ignition knob in the "LOCK" position.
- Always use CONSULT-III to perform self-diagnosis as a part of each function inspection after finishing work. If DTC is detected, perform trouble diagnosis according to self-diagnostic results.

For models equipped with the Intelligent Key system and NATS, an electrically controlled steering lock mechanism is adopted on the key cylinder.

For this reason, if the battery is disconnected or if the battery is discharged, the steering wheel will lock and steering wheel rotation will become impossible.

If steering wheel rotation is required when battery power is interrupted, follow the procedure below before starting the repair operation.

OPERATION PROCEDURE

1. Connect both battery cables.

NOTE:

Supply power using jumper cables if battery is discharged.

2. Use the Intelligent Key or mechanical key to turn the ignition switch to the "ACC" position. At this time, the steering lock will be released.
3. Disconnect both battery cables. The steering lock will remain released and the steering wheel can be rotated.
4. Perform the necessary repair operation.

PRECAUTIONS

< PRECAUTION >

5. When the repair work is completed, return the ignition switch to the "LOCK" position before connecting the battery cables. (At this time, the steering lock mechanism will engage.)
6. Perform a self-diagnosis check of all control units using CONSULT-III.

A

B

C

D

E

F

G

H

I

IP

K

L

M

N

O

P

PREPARATION

< PREPARATION >

PREPARATION

PREPARATION

Special Service Tool

INFOID:000000003775416

The actual shapes of Kent-Moore tools may differ from those of special service tools illustrated here.

Tool number (Kent-Moore No.) Tool name	Description
— (J-39570) Chassis ear	Locating the noise
— (J-43980) NISSAN Squeak and Rattle kit	Repairing the cause of noise
— (J-46534) Trim Tool Set	Removing trim components

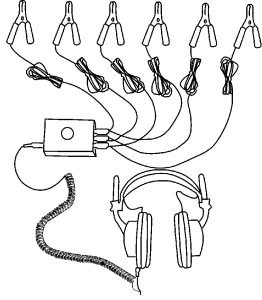

SBT839

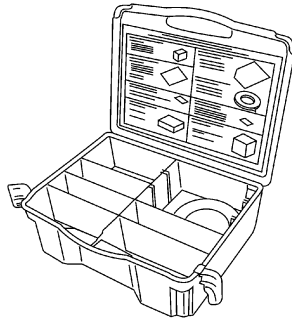

SBT840

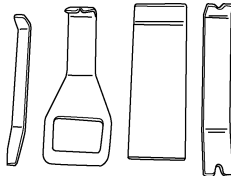

AWJIA0483ZZ

Commercial Service Tool

INFOID:000000003775417

PREPARATION

< PREPARATION >

(Kent-Moore No.) Tool name	Description	A
(J-39565) Engine ear	Locating the noise	B C
Power Tool	Loosening bolts and nuts	D E F

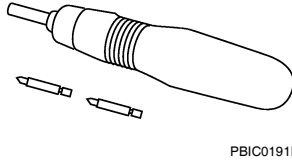
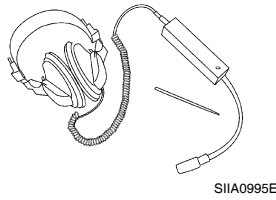

IP

K
 L
 M
 N
 O
 P

SQUEAK AND RATTLE TROUBLE DIAGNOSES

< SYMPTOM DIAGNOSIS >

SYMPTOM DIAGNOSIS

SQUEAK AND RATTLE TROUBLE DIAGNOSES

Work Flow

INFOID:000000003775418

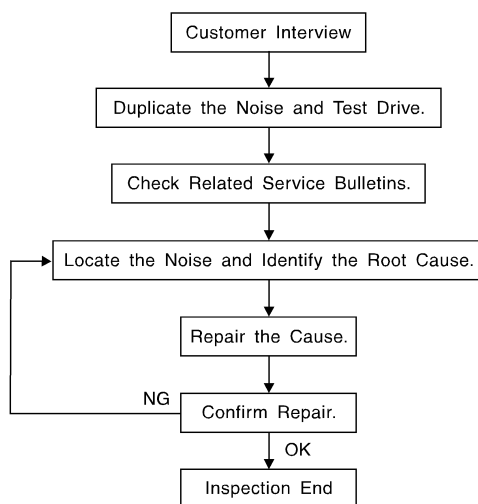

SBT842

CUSTOMER INTERVIEW

Interview the customer if possible, to determine the conditions that exist when the noise occurs. Use the Diagnostic Worksheet during the interview to document the facts and conditions when the noise occurs and any customer's comments; refer to [IP-10, "Diagnostic Worksheet"](#). This information is necessary to duplicate the conditions that exist when the noise occurs.

- The customer may not be able to provide a detailed description or the location of the noise. Attempt to obtain all the facts and conditions that exist when the noise occurs (or does not occur).
- If there is more than one noise in the vehicle, be sure to diagnose and repair the noise that the customer is concerned about. This can be accomplished by test driving the vehicle with the customer.
- After identifying the type of noise, isolate the noise in terms of its characteristics. The noise characteristics are provided so the customer, service adviser and technician are all speaking the same language when defining the noise.
- Squeak —(Like tennis shoes on a clean floor)
Squeak characteristics include the light contact/fast movement/brought on by road conditions/hard surfaces = higher pitch noise/softer surfaces = lower pitch noises/edge to surface = chirping.
- Creak—(Like walking on an old wooden floor)
Creak characteristics include firm contact/slow movement/twisting with a rotational movement/pitch dependent on materials/often brought on by activity.
- Rattle—(Like shaking a baby rattle)
Rattle characteristics include the fast repeated contact/vibration or similar movement/loose parts/missing clip or fastener/incorrect clearance.
- Knock —(Like a knock on a door)
Knock characteristics include hollow sounding/sometimes repeating/often brought on by driver action.
- Tick—(Like a clock second hand)
Tick characteristics include gentle contacting of light materials/loose components/can be caused by driver action or road conditions.
- Thump—(Heavy, muffled knock noise)
Thump characteristics include softer knock/dead sound often brought on by activity.
- Buzz—(Like a bumble bee)
Buzz characteristics include high frequency rattle/firm contact.
- Often the degree of acceptable noise level will vary depending upon the person. A noise that you may judge as acceptable may be very irritating to the customer.
- Weather conditions, especially humidity and temperature, may have a great effect on noise level.

DUPLICATE THE NOISE AND TEST DRIVE

SQUEAK AND RATTLE TROUBLE DIAGNOSES

< SYMPTOM DIAGNOSIS >

If possible, drive the vehicle with the customer until the noise is duplicated. Note any additional information on the Diagnostic Worksheet regarding the conditions or location of the noise. This information can be used to duplicate the same conditions when you confirm the repair.

If the noise can be duplicated easily during the test drive, to help identify the source of the noise, try to duplicate the noise with the vehicle stopped by doing one or all of the following:

- 1) Close a door.
 - 2) Tap or push/pull around the area where the noise appears to be coming from.
 - 3) Rev the engine.
 - 4) Use a floor jack to recreate vehicle "twist".
 - 5) At idle, apply engine load (electrical load, and shift selector in drive position with brakes applied).
 - 6) Raise the vehicle on a hoist and hit a tire with a rubber hammer.
- Drive the vehicle and attempt to duplicate the conditions the customer states exist when the noise occurs.
 - If it is difficult to duplicate the noise, drive the vehicle slowly on an undulating or rough road to stress the vehicle body.

CHECK RELATED SERVICE BULLETINS

After verifying the customer concern or symptom, check ASIST for Technical Service Bulletins (TSBs) related to that concern or symptom.

If a TSB relates to the symptom, follow the procedure to repair the noise.

LOCATE THE NOISE AND IDENTIFY THE ROOT CAUSE

1. Narrow down the noise to a general area. To help pinpoint the source of the noise, use a listening tool (Chassis Ear: J-39570, Engine Ear: J-39565 and mechanic's stethoscope).
2. Narrow down the noise to a more specific area and identify the cause of the noise by:
 - removing the components in the area that you suspect the noise is coming from.
Do not use too much force when removing clips and fasteners, otherwise clips and fasteners can be broken or lost during the repair, resulting in the creation of new noise.
 - tapping or pushing/pulling the component that you suspect is causing the noise.
Do not tap or push/pull the component with excessive force, otherwise the noise will be eliminated only temporarily.
 - feeling for a vibration with your hand by touching the component(s) that you suspect is (are) causing the noise.
 - placing a piece of paper between components that you suspect are causing the noise.
 - looking for loose components and contact marks.
Refer to [IP-8, "Generic Squeak and Rattle Troubleshooting"](#).

REPAIR THE CAUSE

- If the cause is a loose component, tighten the component securely.
- If the cause is insufficient clearance between components:
 - separate components by repositioning or loosening and retightening the component, if possible.
 - insulate components with a suitable insulator such as urethane pads, foam blocks, felt cloth tape or urethane tape. A NISSAN Squeak and Rattle Kit (J-43980) is available through your authorized NISSAN Parts Department.

CAUTION:

Do not use excessive force as many components are constructed of plastic and may be damaged.

Always check with the Parts Department for the latest parts information.

The following materials are contained in the NISSAN Squeak and Rattle Kit (J-43980). Each item can be ordered separately as needed.

URETHANE PADS [1.5 mm (0.059 in) thick]

Insulates connectors, harness, etc.

76268-9E005: 100×135 mm (3.94×5.31 in)/76884-71L01: 60×85 mm (2.36×3.35 in)/76884-71L02: 15×25 mm (0.59×0.98 in)

INSULATOR (Foam blocks)

Insulates components from contact. Can be used to fill space behind a panel.

73982-9E000: 45 mm (1.77 in) thick, 50×50 mm (1.97×1.97 in)/73982-50Y00: 10 mm (0.39 in) thick, 50×50 mm (1.97×1.97 in)

INSULATOR (Light foam block)

80845-71L00: 30 mm (1.18 in) thick, 30×50 mm (1.18×1.97 in)

FELT CLOTH TAPE

Used to insulate where movement does not occur. Ideal for instrument panel applications.

SQUEAK AND RATTLE TROUBLE DIAGNOSES

< SYMPTOM DIAGNOSIS >

68370-4B000: 15×25 mm (0.59×0.98 in) pad/68239-13E00: 5 mm (0.20 in) wide tape roll. The following materials not found in the kit can also be used to repair squeaks and rattles.

UHMW (TEFLON) TAPE

Insulates where slight movement is present. Ideal for instrument panel applications.

SILICONE GREASE

Used instead of UHMW tape that will be visible or not fit.

Note: Will only last a few months.

SILICONE SPRAY

Use when grease cannot be applied.

DUCT TAPE

Use to eliminate movement.

CONFIRM THE REPAIR

Confirm that the cause of a noise is repaired by test driving the vehicle. Operate the vehicle under the same conditions as when the noise originally occurred. Refer to the notes on the Diagnostic Worksheet.

Generic Squeak and Rattle Troubleshooting

INFOID:000000003775419

Refer to Table of Contents for specific component removal and installation information.

INSTRUMENT PANEL

Most incidents are caused by contact and movement between:

1. The cluster lid A and instrument panel
2. Acrylic lens and combination meter housing
3. Instrument panel to front pillar garnish
4. Instrument panel to windshield
5. Instrument panel mounting pins
6. Wiring harnesses behind the combination meter
7. A/C defroster duct and duct joint

These incidents can usually be located by tapping or moving the components to duplicate the noise or by pressing on the components while driving to stop the noise. Most of these incidents can be repaired by applying felt cloth tape or silicone spray (in hard to reach areas). Urethane pads can be used to insulate wiring harnesses.

CAUTION:

Do not use silicone spray to isolate a squeak or rattle. If you saturate the area with silicone, you will not be able to recheck the repair.

CENTER CONSOLE

Components to pay attention to include:

1. Shifter assembly cover to finisher
2. A/C control unit and cluster lid C
3. Wiring harnesses behind audio and A/C control unit

The instrument panel repair and isolation procedures also apply to the center console.

DOORS

Pay attention to the:

1. Finisher and inner panel making a slapping noise
2. Inside handle escutcheon to door finisher
3. Wiring harnesses tapping
4. Door striker out of alignment causing a popping noise on starts and stops

Tapping or moving the components or pressing on them while driving to duplicate the conditions can isolate many of these incidents. You can usually insulate the areas with felt cloth tape or insulator foam blocks from the NISSAN Squeak and Rattle Kit (J-43980) to repair the noise.

TRUNK

Trunk noises are often caused by a loose jack or loose items put into the trunk by the owner.

In addition look for:

1. Trunk lid bumpers out of adjustment

SQUEAK AND RATTLE TROUBLE DIAGNOSES

< SYMPTOM DIAGNOSIS >

2. Trunk lid striker out of adjustment
3. The trunk lid torsion bars knocking together
4. A loose license plate or bracket

Most of these incidents can be repaired by adjusting, securing or insulating the item(s) or component(s) causing the noise.

SUNROOF/HEADLINING

Noises in the sunroof/headlining area can often be traced to one of the following:

1. Sunroof lid, rail, linkage or seals making a rattle or light knocking noise
2. Sun visor shaft shaking in the holder
3. Front or rear windshield touching headliner and squeaking

Again, pressing on the components to stop the noise while duplicating the conditions can isolate most of these incidents. Repairs usually consist of insulating with felt cloth tape.

OVERHEAD CONSOLE (FRONT AND REAR)

Overhead console noises are often caused by the console panel clips not being engaged correctly. Most of these incidents are repaired by pushing up on the console at the clip locations until the clips engage.

In addition look for:

1. Loose harness or harness connectors.
2. Front console map/reading lamp lens loose.
3. Loose screws at console attachment points.

SEATS

When isolating seat noise it's important to note the position the seat is in and the load placed on the seat when the noise is present. These conditions should be duplicated when verifying and isolating the cause of the noise.

Cause of seat noise include:

1. Headrest rods and holder
2. A squeak between the seat pad cushion and frame
3. The rear seatback lock and bracket

These noises can be isolated by moving or pressing on the suspected components while duplicating the conditions under which the noise occurs. Most of these incidents can be repaired by repositioning the component or applying urethane tape to the contact area.

UNDERHOOD

Some interior noise may be caused by components under the hood or on the engine wall. The noise is then transmitted into the passenger compartment.

Causes of transmitted underhood noise include:

1. Any component mounted to the engine wall
2. Components that pass through the engine wall
3. Engine wall mounts and connectors
4. Loose radiator mounting pins
5. Hood bumpers out of adjustment
6. Hood striker out of adjustment

These noises can be difficult to isolate since they cannot be reached from the interior of the vehicle. The best method is to secure, move or insulate one component at a time and test drive the vehicle. Also, engine RPM or load can be changed to isolate the noise. Repairs can usually be made by moving, adjusting, securing, or insulating the component causing the noise.

A
B
C
D
E
F
G
H
I
IP
K
L
M
N
O
P

SQUEAK AND RATTLE TROUBLE DIAGNOSES

< SYMPTOM DIAGNOSIS >

Diagnostic Worksheet

INFOID:00000003775420

Dear Customer:

We are concerned about your satisfaction with your vehicle. Repairing a squeak or rattle sometimes can be very difficult. To help us fix your vehicle right the first time, please take a moment to note the area of the vehicle where the squeak or rattle occurs and under what conditions. You may be asked to take a test drive with a service advisor or technician to ensure we confirm the noise you are hearing.

SQUEAK & RATTLE DIAGNOSTIC WORKSHEET

I. WHERE DOES THE NOISE COME FROM? (circle the area of the vehicle)

The illustrations are for reference only, and may not reflect the actual configuration of your vehicle.

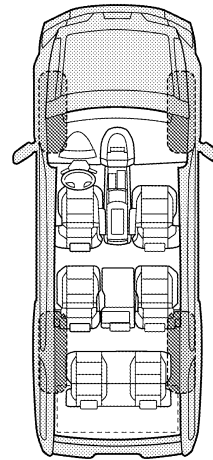
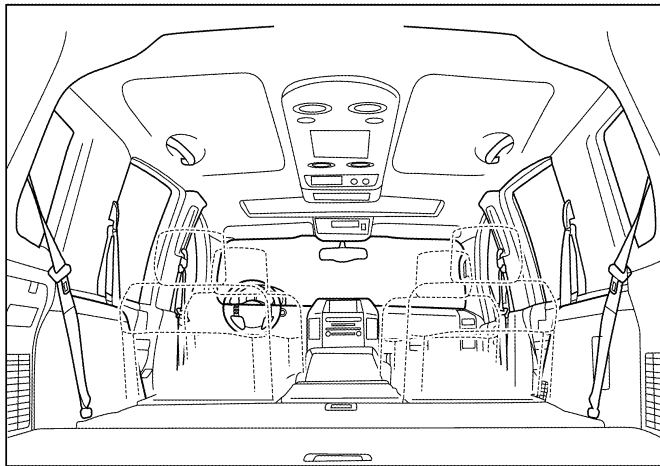
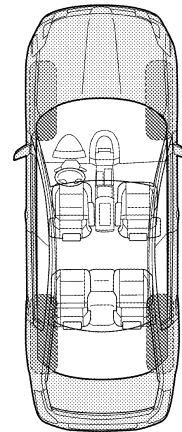
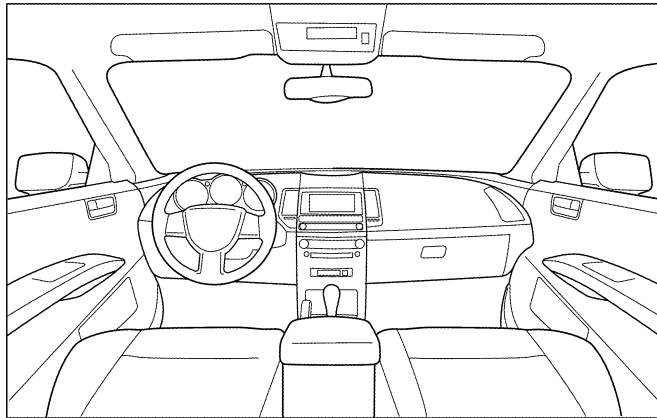

Continue to page 2 of the worksheet and briefly describe the location of the noise or rattle. In addition, please indicate the conditions which are present when the noise occurs.

SQUEAK AND RATTLE TROUBLE DIAGNOSES

< SYMPTOM DIAGNOSIS >

SQUEAK & RATTLE DIAGNOSTIC WORKSHEET - page 2

Briefly describe the location where the noise occurs:

II. WHEN DOES IT OCCUR? (please check the boxes that apply)

- | | |
|---|--|
| <input type="checkbox"/> Anytime | <input type="checkbox"/> After sitting out in the rain |
| <input type="checkbox"/> 1st time in the morning | <input type="checkbox"/> When it is raining or wet |
| <input type="checkbox"/> Only when it is cold outside | <input type="checkbox"/> Dry or dusty conditions |
| <input type="checkbox"/> Only when it is hot outside | <input type="checkbox"/> Other: |

III. WHEN DRIVING:

- Through driveways
- Over rough roads
- Over speed bumps
- Only about ____ mph
- On acceleration
- Coming to a stop
- On turns: left, right or either (circle)
- With passengers or cargo
- Other: _____
- After driving ____ miles or ____ minutes

IV. WHAT TYPE OF NOISE

- Squeak (like tennis shoes on a clean floor)
- Creak (like walking on an old wooden floor)
- Rattle (like shaking a baby rattle)
- Knock (like a knock at the door)
- Tick (like a clock second hand)
- Thump (heavy muffled knock noise)
- Buzz (like a bumble bee)

TO BE COMPLETED BY DEALERSHIP PERSONNEL

Test Drive Notes:

	YES	NO	Initials of person performing
Vehicle test driven with customer	<input type="checkbox"/>	<input type="checkbox"/>	_____
- Noise verified on test drive	<input type="checkbox"/>	<input type="checkbox"/>	_____
- Noise source located and repaired	<input type="checkbox"/>	<input type="checkbox"/>	_____
- Follow up test drive performed to confirm repair	<input type="checkbox"/>	<input type="checkbox"/>	_____

VIN: _____ Customer Name _____
 W.O.# _____ Date: _____

This form must be attached to Work Order

LAI A0071E

A
B
C
D
E
F
G
H
I
IP
K
L
M
N
O
P

INSTRUMENT PANEL ASSEMBLY

< ON-VEHICLE REPAIR >

ON-VEHICLE REPAIR

INSTRUMENT PANEL ASSEMBLY

Exploded View

INFOID:000000003775421

SEC. 680

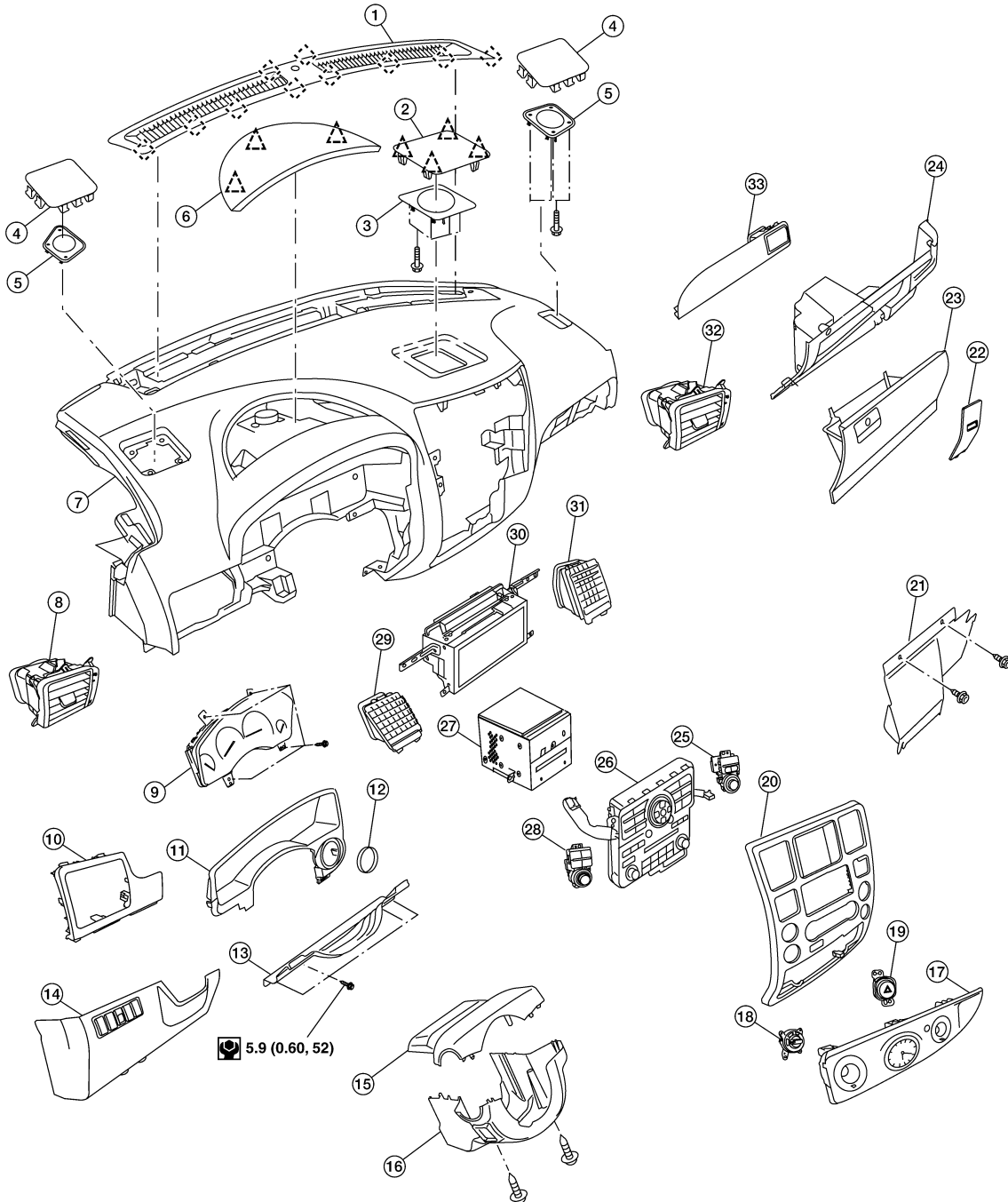

AWJIA0236GB

INSTRUMENT PANEL ASSEMBLY

< ON-VEHICLE REPAIR >

- | | | | |
|--------------------------------------|-----------------------------------|---------------------------------|---|
| 1. Defroster grille | 2. Center speaker grille | 3. Speaker center | A |
| 4. Speaker grille outer | 5. Speaker outer | 6. Instrument panel upper cover | |
| 7. Instrument panel and pad assembly | 8. Side ventilator assembly LH | 9. Combination meter | B |
| 10. Instrument upper panel LH | 11. Cluster lid A | 12. Key cylinder escutcheon | |
| 13. Lower knee protector | 14. Instrument lower panel LH | 15. Steering column cover upper | B |
| 16. Steering column cover lower | 17. Cluster lid C lower | 18. 4WD switch (if equipped) | |
| 19. Hazard switch | 20. Cluster lid C | 21. Instrument lower cover RH | C |
| 22. Fuse access cover | 23. Glove box | 24. Instrument lower panel RH | |
| 25. Audio switch RH | 26. A/C and AV switch assembly | 27. Audio unit | D |
| 28. Audio switch LH | 29. Center ventilator assembly LH | 30. Display assembly | |
| 31. Center ventilator assembly RH | 32. Side ventilator assembly RH | 33. Instrument upper panel RH | D |
- ☐ Metal clip △ Clip

Removal and Installation

INFOID:000000003775422

REMOVAL

CAUTION:

Disconnect both the negative and positive battery terminals in advance.

1. Disconnect both negative and positive terminals, then wait at least 3 minutes.
2. Remove front center console. Refer to [IP-20, "Removal and Installation"](#).
3. Remove steering column assembly. Refer to [ST-20, "Removal and Installation"](#).
4. Remove combination meter. Refer to [MWI-102, "Removal and Installation"](#).
5. Remove instrument panel upper cover and disconnect rear sonar speaker (if equipped).
6. Remove cluster lid C. Refer to [IP-16, "Removal and Installation"](#).
7. Remove display assembly. Refer to [AV-168, "Removal and Installation"](#).
8. Remove instrument lower/upper panel RH and glove box. Refer to [IP-17, "Removal and Installation"](#) and [IP-18, "Removal and Installation"](#).
9. Release the clips, disconnect the optical sensor harness and remove defroster grille.
10. Release the clips, disconnect the connectors and remove RH, LH, and center speakers.
11. Remove RH/LH front pillar finishers. Refer to [INT-14, "Removal and Installation"](#).
12. Remove the passenger air bag module nuts and disconnect the connectors. Refer to [SR-10, "Removal and Installation"](#).
13. Disconnect remaining optional equipment connectors (if equipped).
14. Remove instrument panel and pad assembly screws.

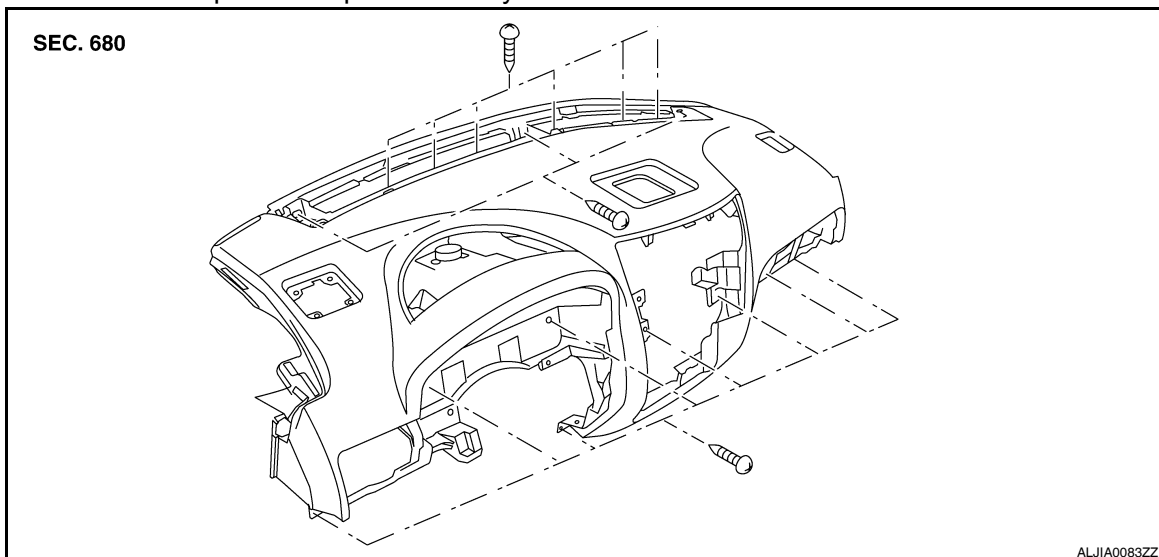

15. Release instrument panel and pad assembly lifting rearward away from steering member, then carefully remove through front door opening.

INSTRUMENT PANEL ASSEMBLY

< ON-VEHICLE REPAIR >

CAUTION:

Always use an assistant to steady the instrument panel and pad assembly during removal from vehicle interior.

INSTALLATION

Installation is in the reverse order of removal.

CLUSTER LID A

< ON-VEHICLE REPAIR >

CLUSTER LID A

Exploded View

INFOID:000000003775423

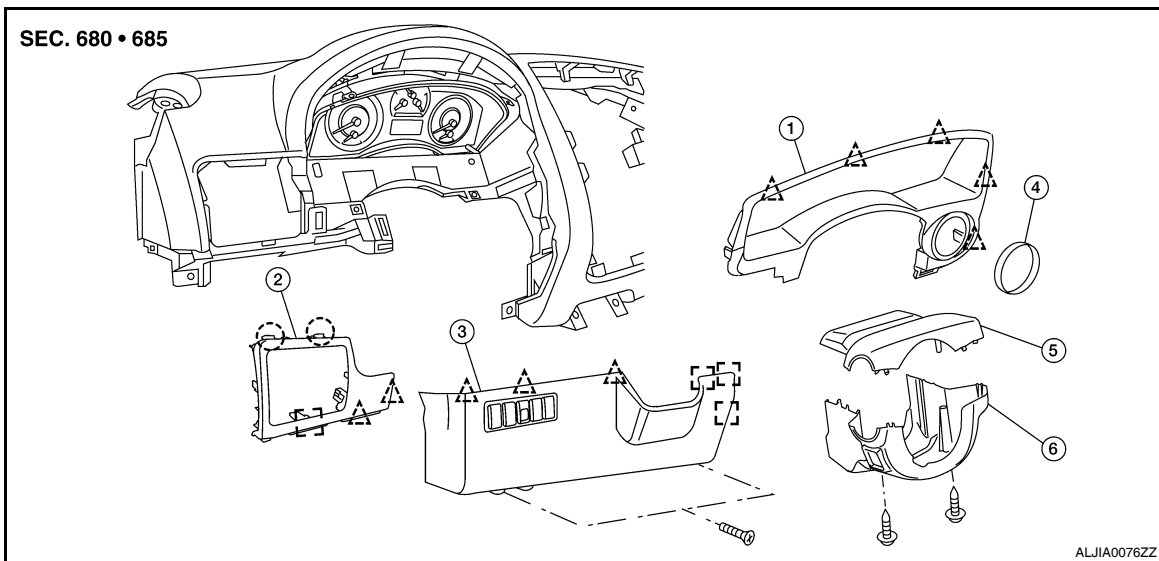

- | | | |
|----------------------------|--------------------------------|--------------------------------|
| 1. Cluster lid A | 2. Instrument upper panel LH | 3. Instrument lower panel LH |
| 4. Key cylinder escutcheon | 5. Steering column cover upper | 6. Steering column cover lower |
| Metal clip | Clip | Pawl |

Removal and Installation

INFOID:000000003775424

REMOVAL

1. Release the clips and remove the screws, then disconnect the connectors and remove instrument lower panel LH.
2. Release the clips then remove instrument upper panel LH.
3. Remove the screws, then remove steering column cover upper and lower from steering column.
4. Remove key cylinder escutcheon from cluster lid A.
5. Release the clips and remove cluster lid A from instrument panel and pad assembly.

INSTALLATION

Installation is in the reverse order of removal.

CLUSTER LID C

< ON-VEHICLE REPAIR >

CLUSTER LID C

Exploded View

INFOID:000000003775425

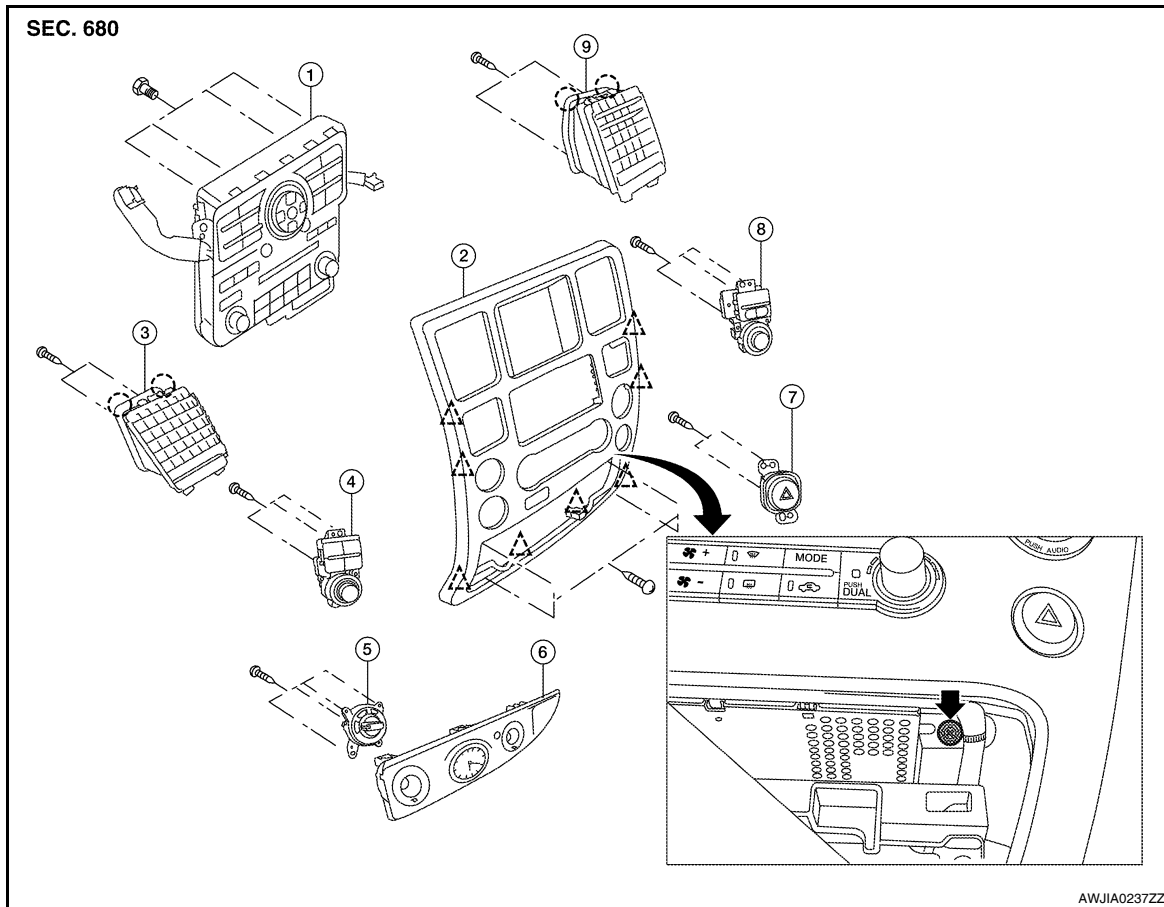

- | | | |
|-------------------------------|-----------------------------|----------------------------------|
| 1. A/C and AV switch assembly | 2. Cluster lid C | 3. Center ventilator assembly LH |
| 4. Audio switch LH | 5. 4WD switch (if equipped) | 6. Cluster lid C lower/clock |
| 7. Hazard switch | 8. Audio switch RH | 9. Center ventilator assembly RH |
- △ Clip ○ Pawl

Removal and Installation

INFOID:000000003775426

REMOVAL

1. Release the clips and remove cluster lid C lower.
2. Remove the upper and lower cluster lid C screws.
3. Release the clips, then pull cluster lid C rearward to remove from instrument panel and pad assembly.
4. Disconnect electrical connectors.

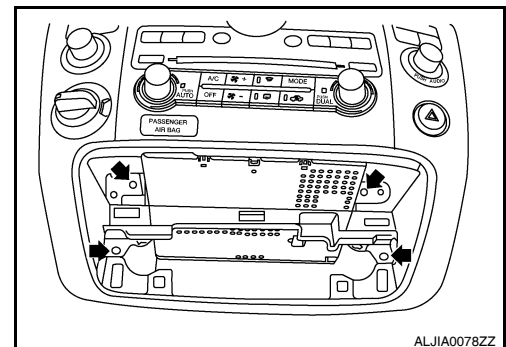

INSTALLATION

Installation is in the reverse order of removal.

INSTRUMENT LOWER PANEL RH AND GLOVE BOX

< ON-VEHICLE REPAIR >

INSTRUMENT LOWER PANEL RH AND GLOVE BOX

Exploded View

INFOID:000000003775427

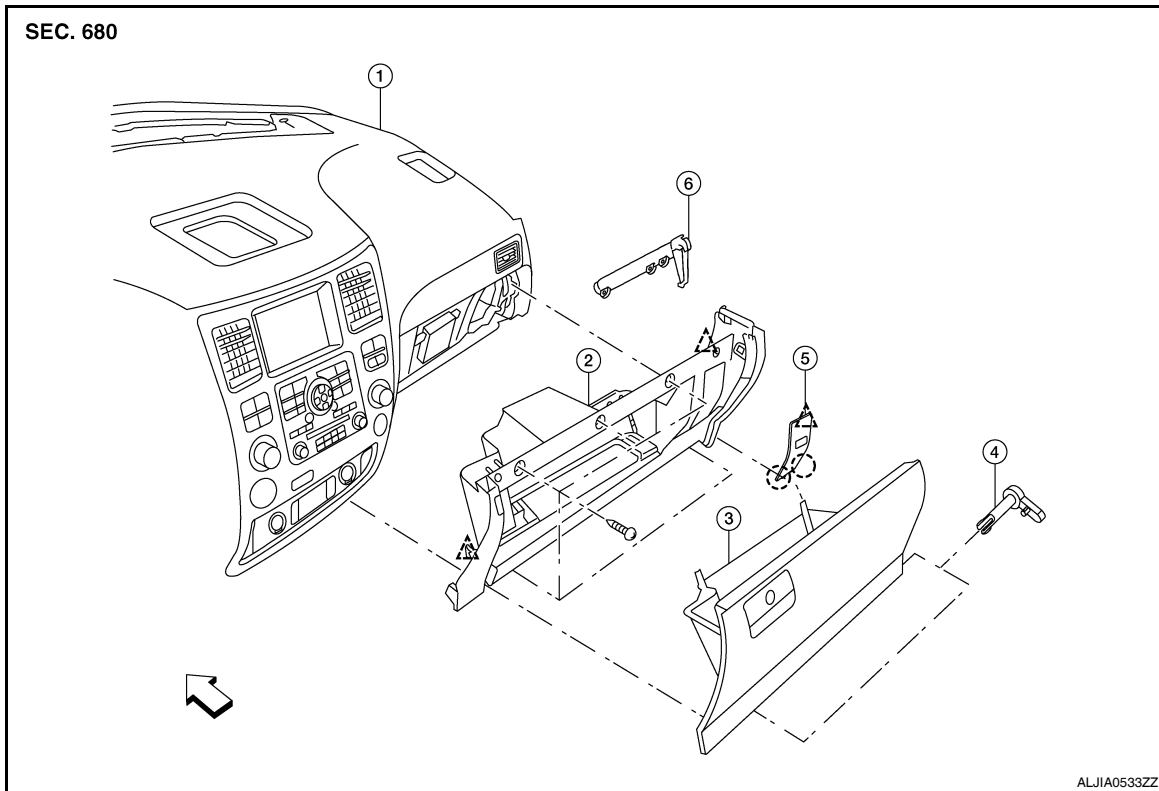

- 1. Instrument panel and pad assembly
- 2. Instrument lower panel RH
- 3. Glove box
- 4. Glove box pivot pin
- 5. Fuse access cover
- 6. Glove box dampener
- △ Clip
- Pawl
- ⇐ Vehicle front

Removal and Installation

INFOID:000000003775428

REMOVAL

1. Remove the instrument lower cover RH.
2. Remove the instrument lower panel RH screws.
3. Release the clips and remove instrument lower panel RH and glove box from instrument panel and pad assembly.
4. Release the clips and remove fuse access cover.
5. Remove glove box pivot pins and damper clip, then remove glove box from instrument panel RH.

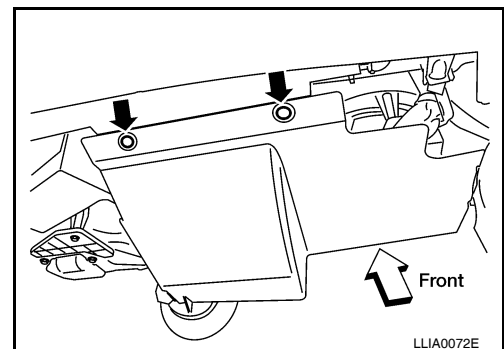

INSTALLATION

Installation is in the reverse order of removal.

INSTRUMENT UPPER PANEL RH

< ON-VEHICLE REPAIR >

INSTRUMENT UPPER PANEL RH

Exploded View

INFOID:000000003775429

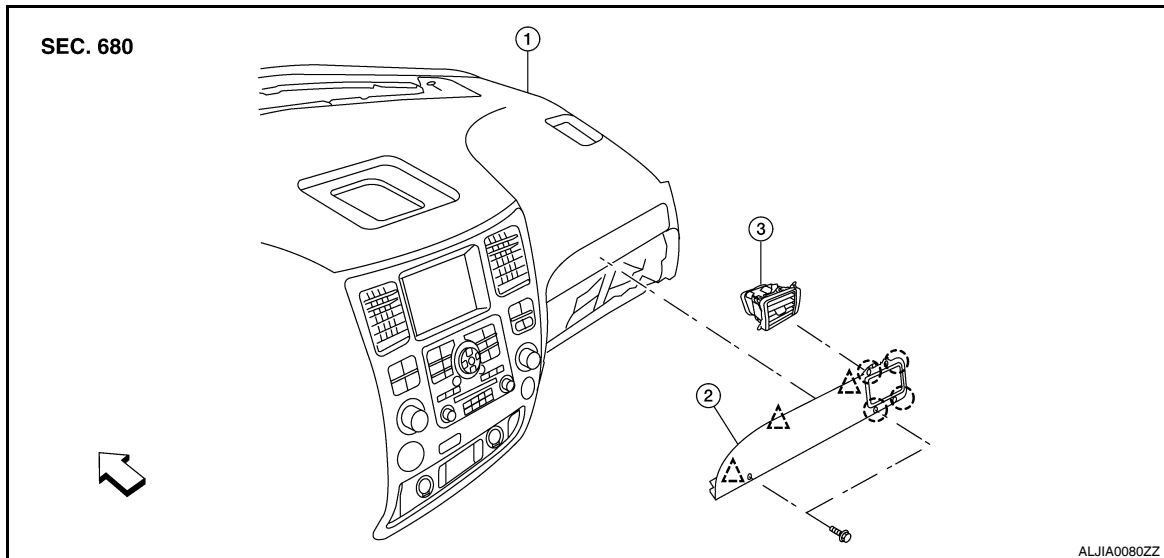

- | | | |
|--------------------------------------|------------------------------|--------------------------------|
| 1. Instrument panel and pad assembly | 2. Instrument upper panel RH | 3. Side ventilator assembly RH |
| Clip | Pawl | Vehicle front |

Removal and Installation

INFOID:000000003775430

REMOVAL

1. Remove instrument lower panel RH and glove box. Refer to [IP-17. "Removal and Installation"](#).
2. Remove instrument upper panel RH screws, then release the clips and remove from instrument panel and pad assembly.

INSTALLATION

Installation is in the reverse order of removal.

A/T FINISHER

< ON-VEHICLE REPAIR >

A/T FINISHER

Removal and Installation

INFOID:000000003775431

REMOVAL

1. Remove the shift lever handle (1).
☐: Metal clips
2. Remove the storage compartment mask (3) and front console upper finisher (4).
3. Pull up on A/T finisher (2) to release clips, then tilt aside.
4. Disconnect A/T finisher electrical connectors and remove from front center console assembly.

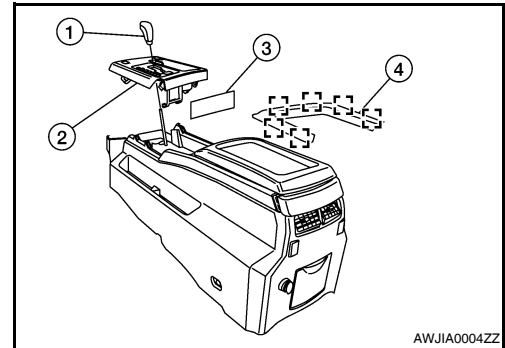

INSTALLATION

Installation is in the reverse order of removal.

A
B
C
D
E
F
G
H
I
IP
K
L
M
N
O
P

FRONT CENTER CONSOLE

< ON-VEHICLE REPAIR >

FRONT CENTER CONSOLE

Exploded View

INFOID:000000003775432

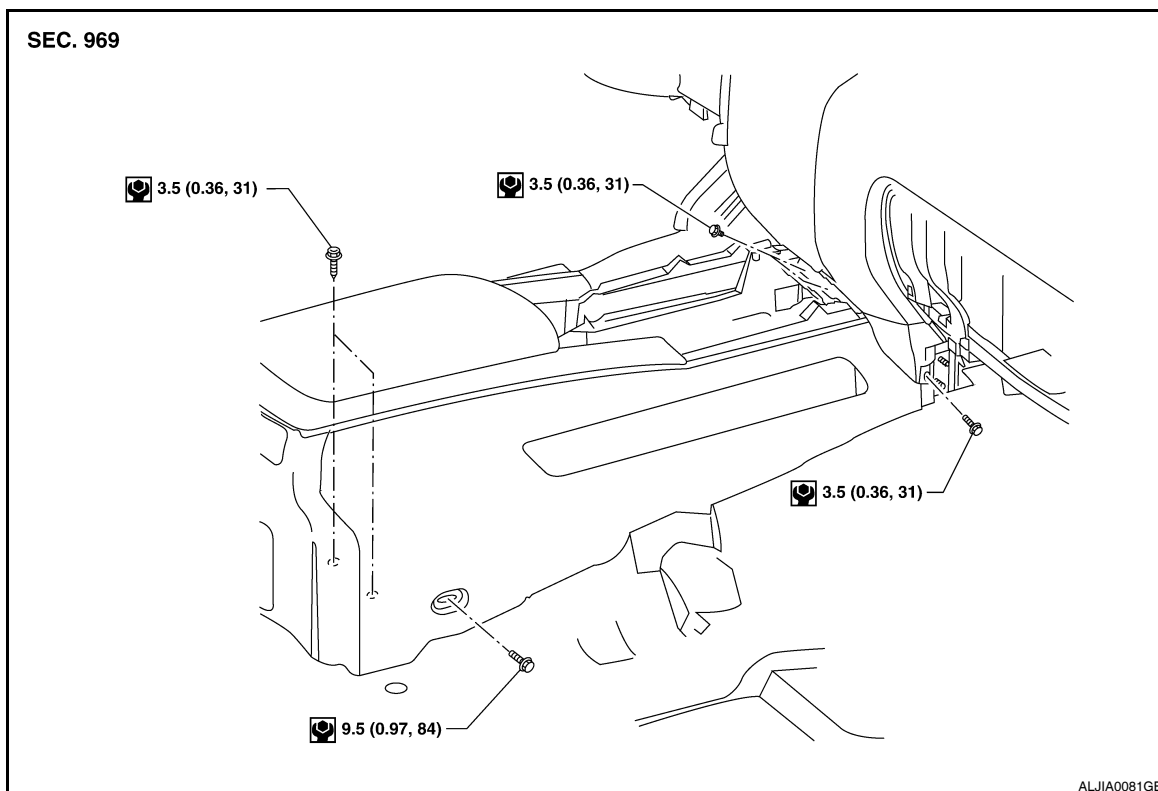

Removal and Installation

INFOID:000000003775433

REMOVAL

1. Move front seats forward.
2. Disconnect the battery negative terminal.
3. Remove cupholder door latch by pushing it forward.
4. Remove A/T finisher and front center console upper screws. Refer to [IP-19. "Removal and Installation"](#).
5. Remove A/T shift selector. Refer to [TM-196. "A/T Shift Selector Removal and Installation"](#).
6. Remove instrument lower panel RH and glove box assembly. Refer to [IP-17. "Removal and Installation"](#).
7. Remove center console lower cover RH/LH, then remove front center console lower screws.
8. Open the console lid assembly and remove console bin mat, then remove the rear inside screws.
9. Remove lower front center console screws at the rear.
10. Release front center console from floor and tilt to disconnect electrical connectors.
11. Carefully remove front center console assembly through rear door opening.

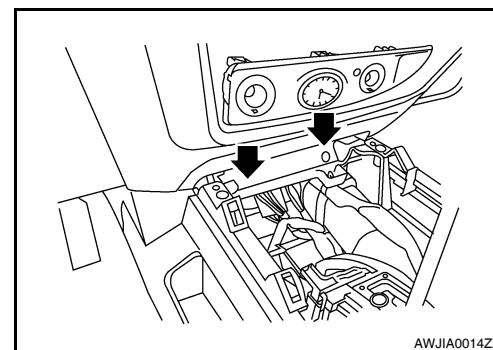

CAUTION:

Always use an assistant to steady the front center console assembly during removal from vehicle interior.

INSTALLATION

Installation is in the reverse order of removal.

REAR CENTER CONSOLE

< ON-VEHICLE REPAIR >

REAR CENTER CONSOLE

Removal and Installation

INFOID:000000003775434

REMOVAL

1. Remove cup holder insert.
2. Release latch and remove rear center console assembly.

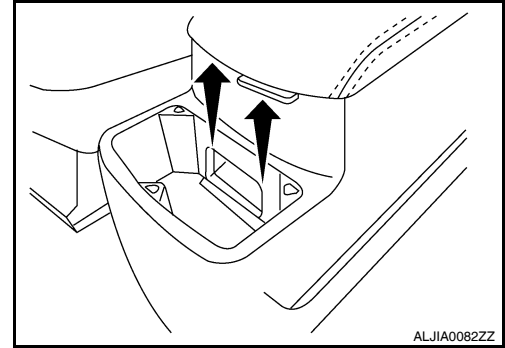

INSTALLATION

Installation is in the reverse order of removal.

A

B

C

D

E

F

G

H

I

IP

K

L

M

N

O

P

FRONT CENTER CONSOLE

< DISASSEMBLY AND ASSEMBLY >

DISASSEMBLY AND ASSEMBLY

FRONT CENTER CONSOLE

Exploded View

INFOID:000000003775435

SEC.969

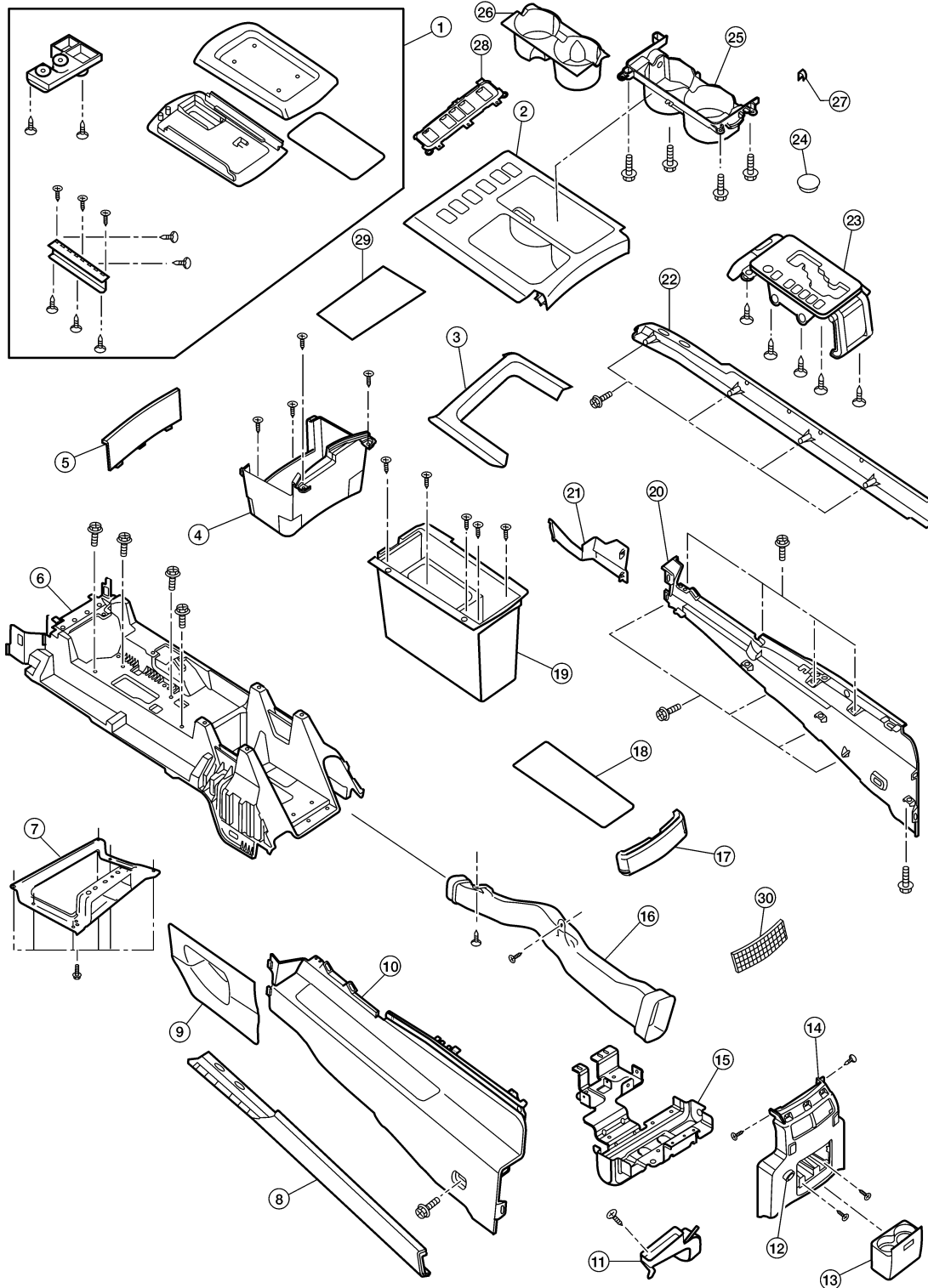

AWJIA0506ZZ

FRONT CENTER CONSOLE

< DISASSEMBLY AND ASSEMBLY >

1. Console lid assembly	2. A/T finisher	3. Console upper finisher	A
4. Storage compartment	5. Storage compartment mask	6. Console reinforcement assembly	
7. Console front bracket	8. Lower side finisher LH	9. Center console lower cover LH	
10. Console cover LH	11. Rear console duct	12. Console power socket	B
13. Rear cup holder assembly	14. Rear finisher assembly	15. Console rear bracket	
16. Heat duct	17. Rear upper finisher	18. Console bin mat	
19. Console bin	20. Console cover RH	21. Center console lower cover RH	C
22. Lower side finisher RH	23. A/T shift selector	24. Mask	
25. Cup holder assembly	26. Cup holder insert	27. Cup holder latch	
28. Console switch bezel	29. Console mat	30. Rear finisher ventilator grille	D

Disassembly and Assembly

INFOID:000000003775436

DISASSEMBLY

1. Remove latch from console lid.
2. Remove console lid and lid hinge.
3. Remove console bin.
4. Disconnect electrical harness connector from DVD player (if equipped).
5. Remove rear upper finisher.
6. Remove rear cup holder assembly.
7. Remove rear finisher assembly, tilt aside and disconnect electrical connectors.
8. Remove console power socket, then disconnect electrical connector.
9. Remove screws on each side, release clips and remove console covers RH/LH.
10. Remove storage compartment and mask.
11. Remove console front bracket.
12. Remove heat duct and rear console duct.
13. Remove console rear bracket.

ASSEMBLY

Assembly is in the reverse order of disassembly.

E

F

G

H

I

IP

K

L

M

N

O

P

REAR CENTER CONSOLE

< DISASSEMBLY AND ASSEMBLY >

REAR CENTER CONSOLE

Exploded View

INFOID:000000003775437

SEC. 969

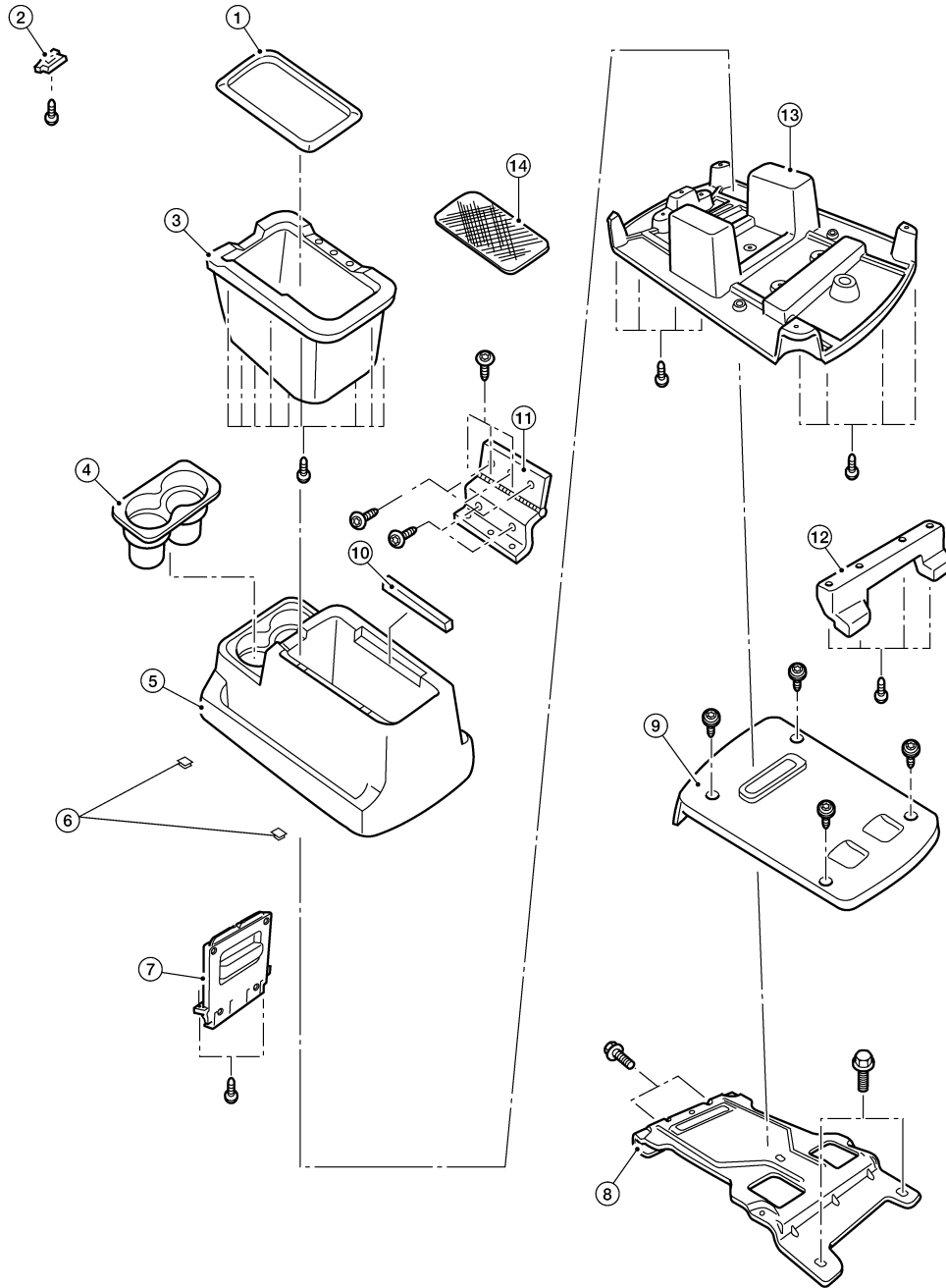

- | | | |
|---------------------------------|--------------------------------|----------------------------|
| 1. Lid assembly | 2. Lid latch | 3. Console bin |
| 4. Cup holder insert | 5. Rear upper console assembly | 6. Rubber bumpers |
| 7. Floor latch | 8. Rear console floor bracket | 9. Rear console floor base |
| 10. Hinge cover | 11. Hinge | 12. Base hook |
| 13. Rear lower console assembly | 14. Console bin mat | |

AWJIA0340GB

REAR CENTER CONSOLE

< DISASSEMBLY AND ASSEMBLY >

Disassembly and Assembly

INFOID:000000003775438

DISASSEMBLY

1. Remove cup holder insert.
2. Remove hinge cover.
3. Remove screws and remove lid assembly.
4. Remove screw and remove latch from lid assembly.
5. Remove screws and remove hinge.
6. Remove screws and separate rear upper console assembly and rear lower console assembly.
7. Remove floor latch from rear upper console assembly.
8. Remove screws and remove console bin from rear upper console assembly.
9. Remove screws and remove rear console floor base.
10. Remove bolts and remove rear console floor bracket.

ASSEMBLY

Assembly is in the reverse order of disassembly.

A

B

C

D

E

F

G

H

I

IP

K

L

M

N

O

P