

SECTION **CCS**

CRUISE CONTROL SYSTEM

A
B
C
D
E
F
G
H
I
J
K
L
M
N
P

CONTENTS

BASIC INSPECTION	3	CONSULT-III Function (ICC)	18
DIAGNOSIS AND REPAIR WORKFLOW	3	COMPONENT DIAGNOSIS	22
Work Flow	3	DTC 11 CONTROL UNIT	22
INSPECTION AND ADJUSTMENT	5	DTC 11 CONTROL UNIT	22
ADDITIONAL SERVICE WHEN REPLACING CONTROL UNIT	5	DTC 12 VDC CONTROL UNIT	23
ADDITIONAL SERVICE WHEN REPLACING CONTROL UNIT : Description	5	DTC 12 VDC CONTROL UNIT	23
ADDITIONAL SERVICE WHEN REPLACING CONTROL UNIT : Special Repair Requirement	5	DTC 20 CAN COMM CIRCUIT	24
LASER BEAM AIMING ADJUSTMENT	5	DTC 20 CAN COMM CIRCUIT	24
LASER BEAM AIMING ADJUSTMENT : Outline of Laser Beam Aiming Adjustment Procedure	5	DTC 31 POWER SUPPLY CIR1, DTC 34 POWER SUPPLY CIR2	25
LASER BEAM AIMING ADJUSTMENT : Preparation	5	DTC 31 POWER SUPPLY CIR1, DTC 34 POWER SUPPLY CIR2	25
LASER BEAM AIMING ADJUSTMENT : Setting up the ICC Target Board	6	DTC 41 VHCL SPEED SE CIRC	26
LASER BEAM AIMING ADJUSTMENT : Sensor Adjustment	7	DTC 41 VHCL SPEED SE CIRC	26
ACTION TEST	8	DTC 43 VDC/TCS/ABS CIRC	27
ACTION TEST : ICC System Running Test	8	DTC 43 VDC/TCS/ABS CIRC	27
FUNCTION DIAGNOSIS	12	DTC 45 BRAKE SW/STOP L SW	28
AUTOMATIC SPEED CONTROL DEVICE (ASCD)	12	DTC 45 BRAKE SW/STOP L SW	28
System Description	12	DTC 46 OPERATION SW CIRC	30
INTELLIGENT CRUISE CONTROL SYSTEM	13	DTC 46 OPERATION SW CIRC	30
System Diagram	13	DTC 74 LASER BEAM OFF CNTR	32
System Description	13	DTC 74 LASER BEAM OFF CNTR	32
Component Parts Location	15	DTC 90 STOP LAMP RLY FIX	33
Component Description	16	DTC 90 STOP LAMP RLY FIX	33
DIAGNOSIS SYSTEM (ICC SENSOR INTEGRATED UNIT)	17	DTC 92 ECM CIRCUIT	38
Diagnosis Description	17	DTC 92 ECM CIRCUIT	38
		DTC 96 NP RANGE	39
		DTC 96 NP RANGE	39
		DTC 97 AT CIRCUIT	40
		DTC 97 AT CIRCUIT	40



DTC 98 GEAR POSITION	41	ICC SYSTEM DOES NOT CANCEL WHEN A/ T SELECTOR LEVER SETS ON "N"	62
DTC 98 GEAR POSITION	41	Diagnosis Procedure	62
DTC 102 LASER STAIN	42	CHIME DOES NOT SOUND	63
DTC 102 LASER STAIN	42	Diagnosis Procedure	63
DTC 103 LASER SENSOR FAIL	43	DRIVING FORCE IS HUNTING	64
DTC 103 LASER SENSOR FAIL	43	Diagnosis Procedure	64
DTC 104 LASER AIMING INCOMP	44	ICC SYSTEM FREQUENTLY CANNOT DE- TECT THE VEHICLE AHEAD/ DETECTION ZONE IS SHORT	65
DTC 104 LASER AIMING INCOMP	44	Diagnosis Procedure	65
DTC 107 LASER COMM FAIL	45	THE SYSTEM DOES NOT DETECT THE VE- HICLE AHEAD AT ALL	66
DTC 107 LASER COMM FAIL	45	Diagnosis Procedure	66
DTC109 LASER HIGH TEMP	46	NORMAL OPERATING CONDITION	67
DTC 109 LASER HIGH TEMP	46	Description	67
ECU DIAGNOSIS	47	PRECAUTION	69
ICC UNIT	47	PRECAUTIONS	69
Terminal and Reference Value for ICC Unit	47	Precaution for Supplemental Restraint System (SRS) "AIR BAG" and "SEAT BELT PRE-TEN- SIONER"	69
Wiring Diagram	48	ICC System Service	69
Fail Safe	55	PREPARATION	70
Diagnostic Trouble Code (DTC) Chart	56	PREPARATION	70
SYMPTOM DIAGNOSIS	58	Special Service Tool	70
INTELLIGENT CRUISE CONTROL SYSTEM SYMPTOMS	58	ON-VEHICLE REPAIR	71
Symptom Chart	58	ICC C/U	71
MAIN SWITCH DOES NOT TURN ON, MAIN SWITCH DOES NOT TURN OFF	59	ICC Unit	71
Diagnosis Procedure	59	ICC SENSOR INTEGRATED UNIT	72
ICC SYSTEM CANNOT BE SET (MAIN SWITCH TURNS ON/OFF)	60	ICC Sensor	72
Diagnosis Procedure	60	ICC STEERING SWITCH	73
ICC STEERING SWITCH (OTHER THAN MAIN SWITCH) DOES NOT FUNCTION	61	Removal and Installation	73
Diagnosis Procedure	61		

DIAGNOSIS AND REPAIR WORKFLOW

< BASIC INSPECTION >

BASIC INSPECTION

DIAGNOSIS AND REPAIR WORKFLOW

Work Flow

INFOID:000000005145970

OVERALL SEQUENCE

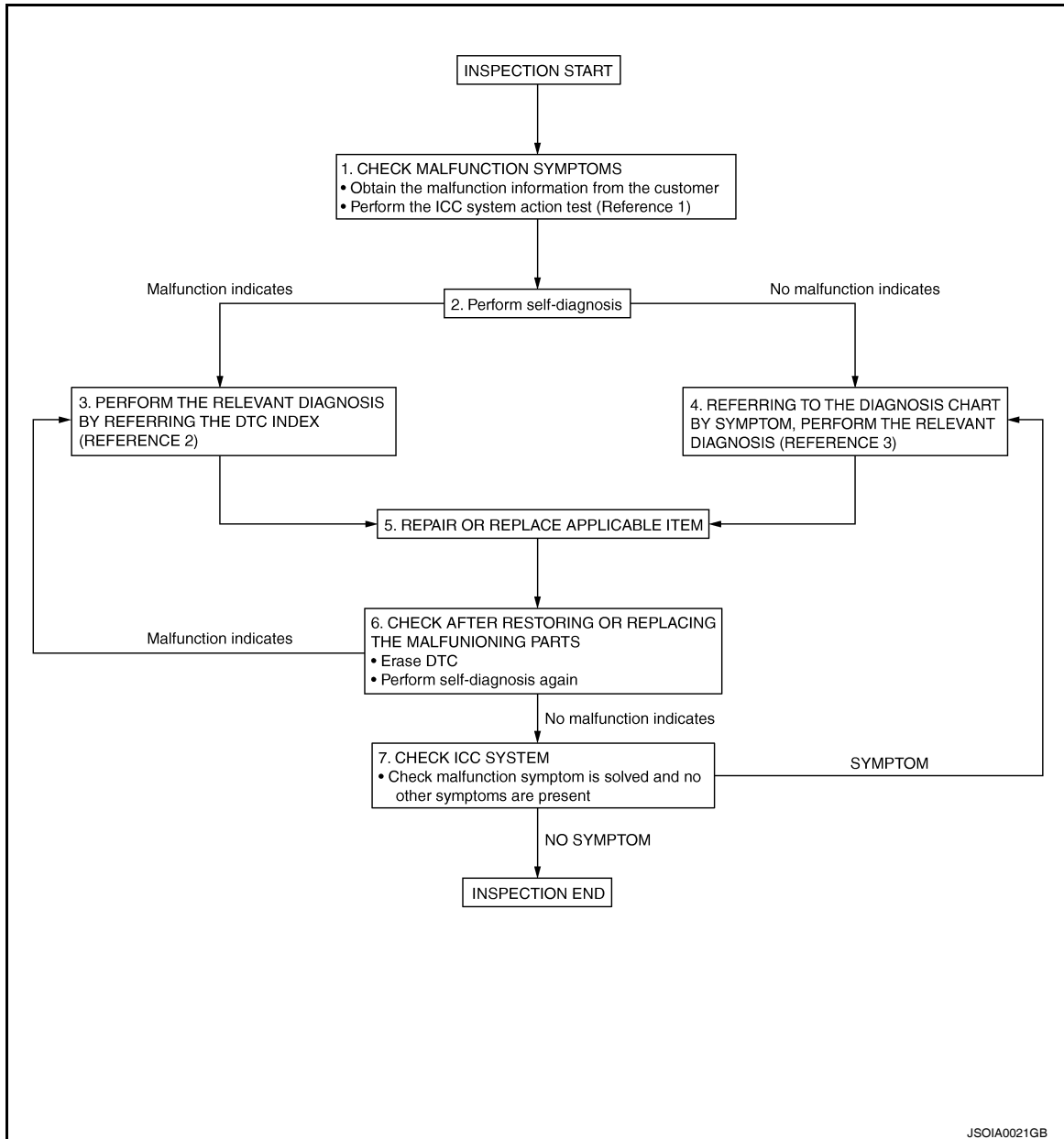

- Reference 1... Refer to [CCS-5, "ADDITIONAL SERVICE WHEN REPLACING CONTROL UNIT : Special Repair Requirement"](#).
- Reference 2... Refer to [CCS-56, "Diagnostic Trouble Code \(DTC\) Chart"](#).
- Reference 3... Refer to [CCS-58, "Symptom Chart"](#).

DETAILED FLOW

1. CHECK SYMPTOM

Check the malfunction symptoms by performing the following items.

- Obtain the malfunction information (conditions and environment when the malfunction occurred) from the customer.

DIAGNOSIS AND REPAIR WORKFLOW

< BASIC INSPECTION >

- Perform the ICC system action test to check the ICC system operation status. Refer to [CCS-5. "ADDITIONAL SERVICE WHEN REPLACING CONTROL UNIT : Special Repair Requirement"](#).

>> GO TO 2

2.PERFORM SELF-DIAGNOSIS OF ICC UNIT

1. Perform self-diagnosis of ICC unit.
2. Check if DTC is detected.

Is any DTC detected?

- YES >> GO TO 3
NO >> GO TO 4

3.CHECK SELF-DIAGNOSIS RESULTS

1. Check the DTC detected in the self-diagnosis results.
2. Perform the relevant diagnosis by referring to the DTC index. Refer to [CCS-56. "Diagnostic Trouble Code \(DTC\) Chart"](#).

NOTE:

If "CAN COMM CIRCUIT [U1000]" (DTC 20) is displayed, start with the diagnosis for the CAN communication system. Refer to [LAN-87. "Diagnosis Procedure"](#).

>> GO TO 5

4.DIAGNOSIS BY SYMPTOM

Referring to the diagnosis chart by symptom, perform the relevant diagnosis. Refer to [CCS-58. "Symptom Chart"](#).

>> GO TO 5

5.REPAIR OR REPLACE APPLICABLE ITEM

Repair or replace applicable item.

>> GO TO 6

6.CHECK AFTER REPAIRING OR REPLACING THE APPLICABLE ITEM

1. Erase DTC.
2. Perform the self-diagnosis for the ICC unit again after repairing or replacing the applicable item.
3. Check if DTC is detected.

Is any DTC detected?

- YES >> GO TO 3
NO >> GO TO 7

7.CHECK ICC SYSTEM

Test the ICC system for normal operation to see if the malfunction symptom is solved and no other symptoms are present.

No symptoms?

- YES >> Inspection End.
NO >> GO TO 4

INSPECTION AND ADJUSTMENT

< BASIC INSPECTION >

INSPECTION AND ADJUSTMENT

ADDITIONAL SERVICE WHEN REPLACING CONTROL UNIT

ADDITIONAL SERVICE WHEN REPLACING CONTROL UNIT : Description

INFOID:000000005145971

Always perform the laser beam aiming adjustment after replacing the ICC unit. In addition, test the ICC system operations to see if it functions normally.

ADDITIONAL SERVICE WHEN REPLACING CONTROL UNIT : Special Repair Requirement

INFOID:000000005145972

1. LASER BEAM AIMING ADJUSTMENT

Adjust laser beam aiming. Refer to [CCS-5. "LASER BEAM AIMING ADJUSTMENT : Outline of Laser Beam Aiming Adjustment Procedure"](#).

>> GO TO 2

2. ICC SYSTEM ACTION TEST

1. Perform the ICC system operation test. Refer to [CCS-8. "ACTION TEST : ICC System Running Test"](#).
2. Check that the ICC system operates normally.

>> INSPECTION END.

LASER BEAM AIMING ADJUSTMENT

LASER BEAM AIMING ADJUSTMENT : Outline of Laser Beam Aiming Adjustment Procedure

INFOID:000000005145973

CAUTION:

- The laser beam aiming adjustment cannot be performed without CONSULT-III.
- The laser beam aiming adjustment must be performed every time the ICC sensor is removed, installed or has been moved as a result of a collision.

1. Prepare the vehicle and the work area.
2. Set up the ICC target board. For details, refer to Technical Service Bulletin.

Tool number : KV99110100 (J-45718)

3. Adjust the sensor following the procedure on CONSULT-III.
4. Check system operation after the adjustment.

LASER BEAM AIMING ADJUSTMENT : Preparation

INFOID:000000005145974

- Place the vehicle on level ground. Shift the transmission into "P" position and release the parking brake.
- Adjust the tire pressure to the specified value.
- See that there is no load in the vehicle. Coolant, engine oil and fuel should be filled to correct level.
- Check that the vehicle suspension has been adjusted to the standard height by the load leveling rear air suspension system. Refer to [SCS-7. "CONSULT-III Function"](#).
- Clean the sensor with a soft cloth.

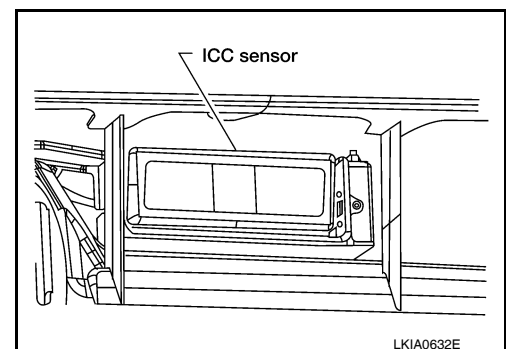

A
B
C
D
E
F
G
H
I
J
K
L
M
N
P

CCS

INSPECTION AND ADJUSTMENT

< BASIC INSPECTION >

LASER BEAM AIMING ADJUSTMENT : Setting up the ICC Target Board

INFOID:000000005145975

CAUTION:

Accuracy in setting up the ICC target board is essential for the laser beam aiming adjustment. For details, refer to Technical Service Bulletin.

ADJUSTING HEIGHT OF THE TARGET

1. Attach a triangle scale as shown.

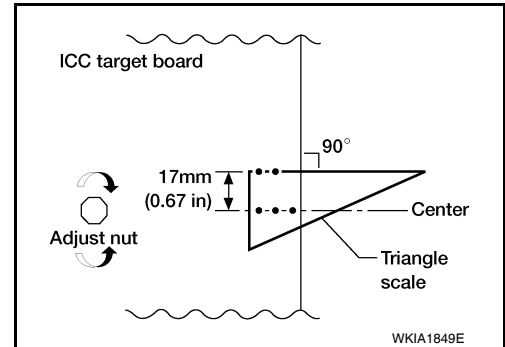

2. Adjust the height of the target stand so that the point of the triangle aims above the center of the ICC sensor.

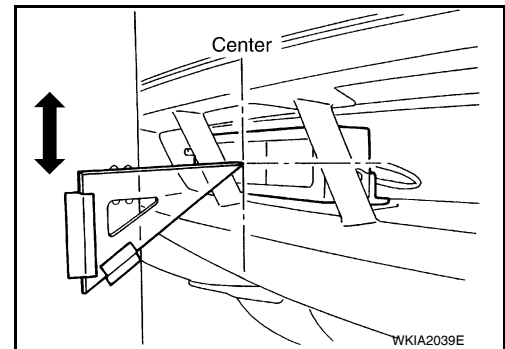

ADJUSTING THE POSITION OF THE TARGET BOARD STRING

1. Attach a scale or straightedge (at least 350 mm [14 in] or longer).

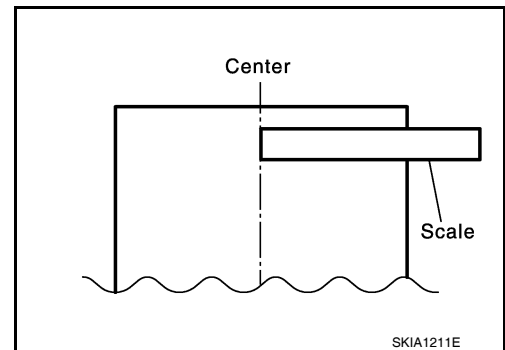

2. Suspend a string with a weight on the end 218 mm (8.6 in) to the left side of the target board center.

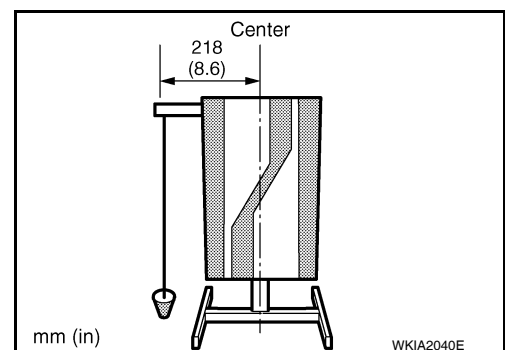

POSITIONING THE TARGET

1. Suspend a string with weights on each end over the centerline of the vehicle. The string should lay over the center of the front and back bumpers. Mark these centerpoints on the ground at each weight.

INSPECTION AND ADJUSTMENT

< BASIC INSPECTION >

2. Connect the two center points using a string. Extend the string an additional 5 m (16 ft) beyond the front centerpoint and mark the floor. Position the target board weight on this mark.

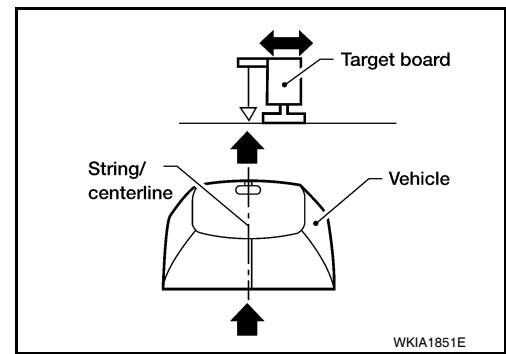

3. Relocate the suspended string from the left side of the target board to the center of the target board. Mark this point on the ground.

4. Pivot the target board on its center mark 20° to either side.
NOTE:
Approx. 50 mm (1.97 in) shift will produce a 20° movement.

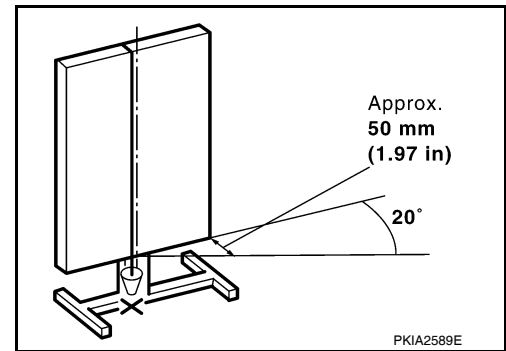

5. Remove any items in the shaded space shown in the figure.

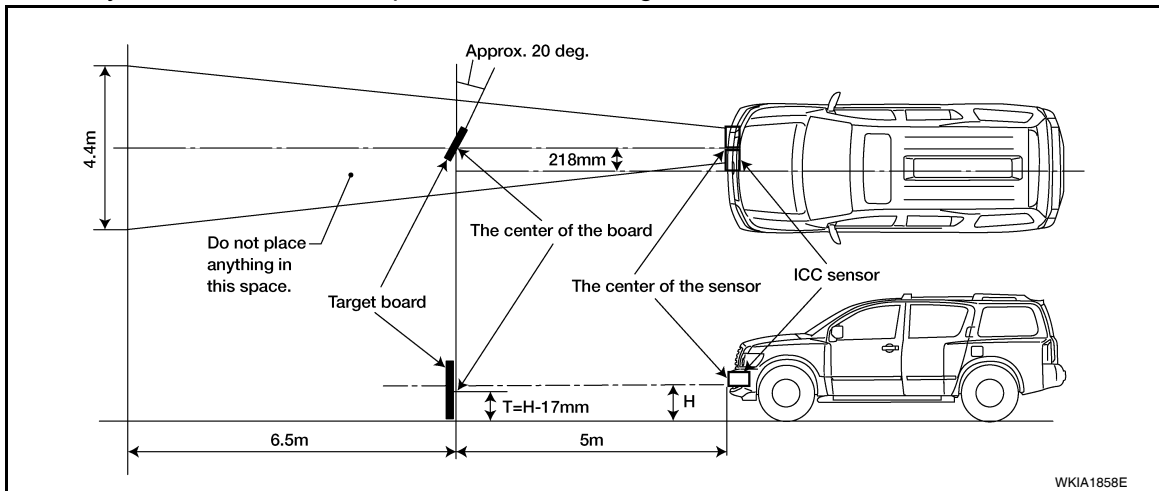

NOTE:

In case the background space shown in the illustration is not available, or if the background is light colored, place a 400 mm (15.75 in) long frosted black board or black cloth to both sides of the target board.

LASER BEAM AIMING ADJUSTMENT : Sensor Adjustment

INFOID:000000005145976

CAUTION:

Never view ICC sensor unit body window directly during laser beam aiming adjustment.

NOTE:

Complete all necessary steps for laser beam adjustment until the CONSULT-III indicates "COMPLETED". If the procedure does not complete, the ICC system is inoperable.

1. SET CONSULT-III TO THE LASER BEAM AIMING ADJUSTMENT MODE

1. Connect CONSULT-III and select "Work Support" of "ICC".
2. Select "LASER BEAM ADJUST".
3. Touch "START".

A
B
C
D
E
F
G
H
I
J
K
L
M
N
P



INSPECTION AND ADJUSTMENT

< BASIC INSPECTION >

NOTE:

If the adjustment screen does not appear on CONSULT-III 10 sec. after touching "LASER BEAM ADJUST" screen, the following causes may be considered:

- Target is not set accurately.
- There is not enough space beside the target.
- Deformation of vehicle or inappropriate installation of sensor. Sensor may be installed out of the adjustable range.
- The area is not suitable for the adjustment work.
- ICC sensor is not clean.

>> GO TO 2

2. LASER BEAM AIMING CONFIRMATION

After the CONSULT-III displays "ADJUST THE VERTICAL OF LASER BEAM AIMING" turn the vertical adjusting screw until "U/D CORRECT" value is set in the range of ± 4 .

NOTE:

- Turn the screw slowly. The value on the CONSULT-III is slower than the actual movement of the ICC sensor. Wait 2 seconds between each adjustment. Also, during adjustment work, do not block the ICC sensor lens with your hand or body. In that case, there are times when aiming cannot be conducted correctly.
- Turning the screw clockwise raises the ICC sensor and counter-clockwise lowers the ICC sensor.

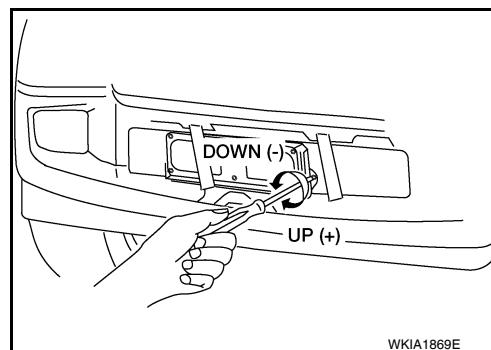

>> GO TO 3

3. LASER BEAM AIMING CONFIRMATION

1. When "U/D CORRECT" value indicates ± 4 , confirm that the value remains within ± 4 for at least 2 seconds while nothing is touching the ICC sensor.
2. When "COMPLETED THE VERTICAL AIMING OF LASER BEAM" appears on screen, touch "END".

NOTE:

Be sure that the margin of "U/D CORRECT" is within ± 4 when the ICC sensor unit is untouched.

3. Confirm that "ADJUSTING AUTOMATIC HORIZONTAL LASER BEAM AIMING" is on screen and wait while the horizontal adjustment is made automatically. (maximum: 10 seconds).
4. Confirm that "NORMALLY COMPLETED" is displayed on CONSULT-III and close the aiming adjustment procedure by touching "END".

NOTE:

Complete all the procedures once "LASER BEAM ADJUST" mode is entered in CONSULT-III. When the procedure is discontinued, the ICC system is inoperable.

>> LASER BEAM AIMING ADJUSTMENT END.

CHECK AFTER THE ADJUSTMENT

Test the ICC system by performing the ICC System Running Test. Refer to [CCS-8. "ACTION TEST : ICC System Running Test"](#).

ACTION TEST

ACTION TEST : ICC System Running Test

INFOID:000000005145977

VEHICLE-TO-VEHICLE DISTANCE CONTROL MODE

SET CHECKING

1. Press the ON/OFF switch for less than 1.5 seconds.
2. Drive the vehicle between 40 km/h (25 MPH) and 144 km/h (89 MPH).
3. Push the COAST/SET switch.
4. Confirm that the desired speed is set as the COAST/SET switch is released.

NOTE:

INSPECTION AND ADJUSTMENT

< BASIC INSPECTION >

- When there is no vehicle ahead, drive at the set speed steadily.
- When there is a vehicle ahead, control to maintain distance from the vehicle ahead, watching its speed.
- The set vehicle speed is displayed on the ICC system indicator in the combination meter.

CHECK FOR INCREASE OF THE CRUISING SPEED

1. Set vehicle-to-vehicle distance control mode at desired speed.
2. Check if the set speed increases by 1.6 km/h (1 MPH) as ACCEL/RES switch is pushed.

NOTE:

The maximum set speed of the vehicle-to-vehicle distance control mode is 144 km/h (89 MPH).

CHECK FOR DECREASE OF THE CRUISING SPEED

1. Set vehicle-to-vehicle distance control mode at desired speed.
2. Check if the set speed decreases by 1.6 km/h (1 MPH) as COAST/SET switch is pushed.

NOTE:

- Vehicle-to-vehicle distance control mode is automatically turned off when the driving speed lowers to 32 km/h (20 MPH) due to the deceleration of the vehicle ahead.
- The minimum set speed of the vehicle-to-vehicle distance control mode is 40 km/h (25 MPH).

CHECK FOR THE CANCELLATION OF VEHICLE-TO-VEHICLE DISTANCE CONTROL MODE (NORMAL DRIVING CONDITION) IN THE FOLLOWING CASES:

1. When the brake pedal is depressed after the system is turned on.
2. When the selector lever is shifted to the "N" (Neutral) position.
3. When the system is turned off.
4. When CANCEL switch is operated.

CHECK FOR RESTORING THE SPEED THAT IS SET BY VEHICLE-TO-VEHICLE DISTANCE CONTROL MODE BEFORE CANCELLATION

1. Cancel the system by depressing the brake. Then, check that the speed before cancellation is restored when pressing ACCEL/RES switch with vehicle speed at 40 km/h (25 MPH) or above.
2. Cancel the system by shifting the selector lever to "N". Then, check if the speed set before the cancellation is restored when ACCEL/RES switch is pressed.
3. Check if the speed previously set is restored when ACCEL/RES switch is operated when driving 40 km/h (25 MPH) or above, after canceling vehicle-to-vehicle distance control mode by operating the CANCEL switch.

CHECK ON/OFF SWITCH OPERATION

1. Start the engine. Then, check that the following operations are performed correctly.
2. Vehicle-to-vehicle distance control mode is displayed when ON/OFF switch is pressed ON. Vehicle-to-vehicle distance control mode goes off when ON/OFF switch is turned to OFF.
3. Turn off the ignition switch while ON/OFF switch is ON. Turn the ignition switch back to ON and confirm that CRUISE lamp and ICC system display are OFF.

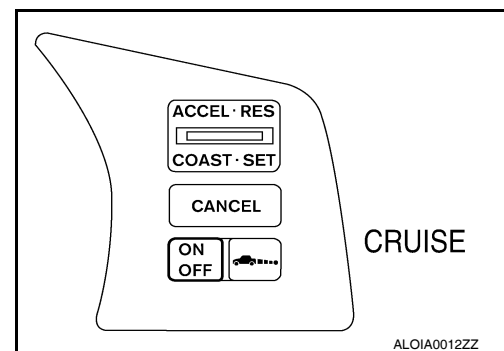

CHECK FOR ACCEL/RES, COAST/SET, CANCEL SWITCHES

1. Check if ACCEL/RES, COAST/SET, CANCEL switches operate smoothly.
2. Check if switch buttons rebound as the buttons are released.

CHECK FOR DISTANCE SWITCH

1. Start the engine.
2. Press the ON/OFF switch for less than 1.5 seconds.
3. Press the DISTANCE switch.
4. Check if the set distance indicator changes display in order of: (long)→(middle)→(short).

NOTE:



A
B
C
D
E
F
G
H
I
J
K
L
M
N

P

INSPECTION AND ADJUSTMENT

< BASIC INSPECTION >

The set distance indicator shows long immediately after the engine starts.

Distance	Display	Approximate distance at 60 MPH (100 km/h) [ft (m)]
Long		195 (60)
Middle		130 (40)
Short		90 (30)

SKIA6178E

CONVENTIONAL (FIXED SPEED) CRUISE CONTROL MODE

SET CHECKING

1. Press the ON/OFF switch for more than 1.5 seconds.
2. Drive the vehicle between 40 km/h (25 MPH) and 144 km/h (89 MPH).
3. Push the COAST/SET switch.
4. Confirm that the desired speed is set when the COAST/SET switch is released.

NOTE:

- ICC system display in the combination meter shows nothing.

CHECK FOR INCREASE OF THE CRUISING SPEED

1. Set the conventional (fixed speed) cruise control mode at desired speed.
2. Check if the set speed increases by 1.6 km/h (1 MPH) as ACCEL/RES switch is pushed.

NOTE:

- If the ACCEL/RES switch is held, the vehicle speed increases until the switch is released.
- The maximum set speed is 144 km/h (89 MPH).

CHECK FOR DECREASE OF THE CRUISING SPEED

1. Set the conventional (fixed speed) cruise control mode at desired speed.
2. Check if the set speed decreases by 1.6 km/h (1 MPH) as COAST/SET switch is pushed.

NOTE:

- Conventional (fixed speed) cruise control mode is automatically turned off when the driving speed lowers to 32 km/h (20 MPH).
- The lowest set speed is 40 km/h (25 MPH).

CHECK FOR THE CANCELLATION OF CONVENTIONAL (FIXED SPEED) CRUISE CONTROL MODE (NORMAL DRIVING CONDITION) IN THE FOLLOWING CASES:

Refer to "CHECK FOR THE CANCELLATION OF VEHICLE-TO-VEHICLE DISTANCE CONTROL MODE (NORMAL DRIVING CONDITION) IN THE FOLLOWING CASES:" .

CHECK FOR RESTORING THE SPEED THAT IS SET BY CONVENTIONAL (FIXED SPEED) CRUISE CONTROL MODE BEFORE ICC CANCELLATION

Refer to "CHECK FOR RESTORING THE SPEED THAT IS SET BY VEHICLE-TO-VEHICLE DISTANCE CONTROL MODE BEFORE CANCELLATION" .

CHECK ON/OFF SWITCH OPERATION

INSPECTION AND ADJUSTMENT

< BASIC INSPECTION >

1. Start the engine. Then, check that the following operations are performed correctly.
2. CRUISE lamp illuminates and ICC system indicator goes off when ON/OFF switch is pressed ON for more than 1.5 seconds. The CRUISE lamp goes off when ON/OFF switch is turned to OFF.
3. Turn off the ignition switch while ON/OFF switch is ON. Turn the ignition switch back to ON and confirm that CRUISE lamp is OFF.

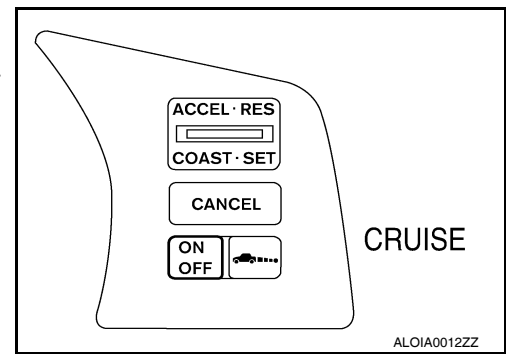

CHECK FOR ACCEL/RES, COAST/SET, CANCEL SWITCHES

1. Check if ACCEL/RES, COAST/SET, CANCEL switches operate smoothly.
2. Check if switch buttons rebound as the buttons are released.

A
B
C
D
E
F
G
H
I
J
K
L
M
N
P

CCS

AUTOMATIC SPEED CONTROL DEVICE (ASCD)

< FUNCTION DIAGNOSIS >

FUNCTION DIAGNOSIS

AUTOMATIC SPEED CONTROL DEVICE (ASCD)

System Description

INFOID:000000005145978

For information regarding the automatic speed control device, refer to [EC-33, "System Description"](#).

INTELLIGENT CRUISE CONTROL SYSTEM

< FUNCTION DIAGNOSIS >

INTELLIGENT CRUISE CONTROL SYSTEM

System Diagram

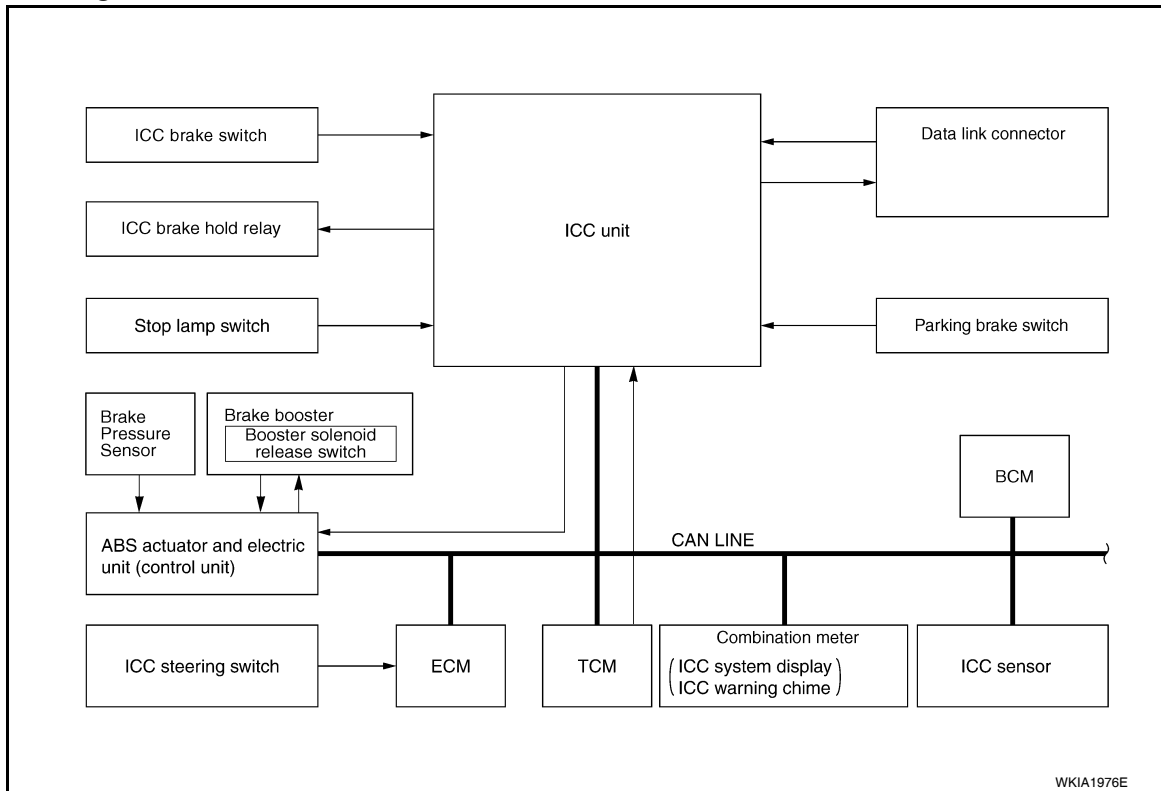

System Description

INFOID:000000005145980

- The Intelligent Cruise Control (ICC) system automatically maintains a selected distance from the vehicle ahead according to that vehicle's speed, or at the set speed, if the road ahead is clear.
- The ICC function has two cruise control modes and brake assist (with preview function).
- To activate or deactivate the ICC system and set the vehicle speed and vehicle-to-vehicle distance, use the ICC steering switch.
- The operation status of the ICC system is indicated on the ICC system display of the combination meter.

VEHICLE-TO-VEHICLE DISTANCE CONTROL MODE

- Vehicle-to-vehicle distance control mode, the vehicle can maintain the same speed as other vehicles without the constant need to adjust the set speed as the driver would with a normal cruise control system.
- The system is intended to enhance the operation of the vehicle when following the vehicle traveling in the same lane and direction.
- If the ICC sensor integrated unit detects a slower moving vehicle ahead, the system will reduce speed so that the vehicle ahead can be followed at the selected distance.
- The system automatically controls the throttle and applies the brakes (up to 25% of vehicle braking power) if necessary.
- The detection range of the sensor is approximately 390 ft (120 m) ahead.
- Refer to Owner's Manual for Intelligent Cruise Control System operating instructions.

CONVENTIONAL (FIXED SPEED) CRUISE CONTROL MODE

- Conventional (fixed speed) cruise control mode is cruising at preset speeds.
- Refer to Owner's Manual for Intelligent Cruise Control System operating instructions.

BRAKE ASSIST (WITH PREVIEW FUNCTION)

- When the force applied to brake pedal exceeds a certain level, the Brake Assist is activated and generates a greater braking force than that of a conventional brake booster even with light pedal force.
- When the Preview Function identifies the need to apply the sudden brake by sensing the vehicle ahead in the same lane and the distance and relative speed from it, it applies the brake pre-pressure before driver depresses the brake pedal and improves brake response by reducing its free play.
- Refer to Owner's Manual for BRAKE ASSIST (WITH PREVIEW FUNCTION) operating instructions.

A
B
C
D
E
F
G
H
I
J
K
L
M
N
P

CCS

INTELLIGENT CRUISE CONTROL SYSTEM

< FUNCTION DIAGNOSIS >

ICC STEERING SWITCH

ICC system is operated by MAIN switch and four control switches, all mounted on the steering wheel.

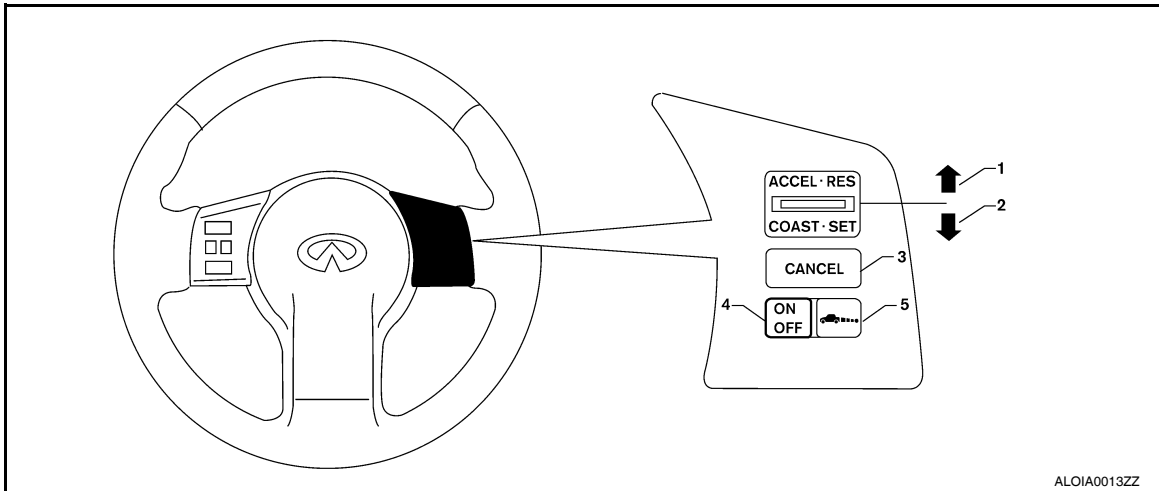

- | | | |
|-----------------------------|---------------------|------------------|
| 1. ACCELERATE/RESUME switch | 2. COAST/SET switch | 3. CANCEL switch |
| 4. ON/OFF switch | 5. DISTANCE switch | |

NOTE:

The on board self-diagnosis function of the ICC system can be started with the RESUME/ACCELERATE switch and SET/COAST switch. Refer to [CCS-17, "Diagnosis Description"](#).

In Vehicle-To-Vehicle Distance Control Mode

No.	Switch name	Description
1	ACCEL/RES switch	Resumes set speed or increases speed incrementally.
2	SET/COAST switch	Sets desired cruise speed or reduces speed incrementally.
3	CANCEL switch	Deactivates system without erasing set speed.
4	ON/OFF switch	Master switch to activate the system.
5	DISTANCE switch	Changes the following distance from: Long, Middle, Short.

In Conventional (Fixed Speed) Cruise Control Mode

No.	Switch name	Description
1	ACCEL/RES switch	Resumes set speed or increases speed incrementally.
2	SET/COAST switch	Sets desired cruise speed or reduces speed incrementally.
3	CANCEL switch	Deactivates system without erasing set speed.
4	ON/OFF switch	Master switch to activate the system.
5	DISTANCE switch	Ineffective in this mode.

ICC SYSTEM DISPLAY

For information about the ICC system display, refer to the Owner Manual.

INTELLIGENT CRUISE CONTROL SYSTEM

< FUNCTION DIAGNOSIS >

Component Parts Location

INFOID:000000005145981

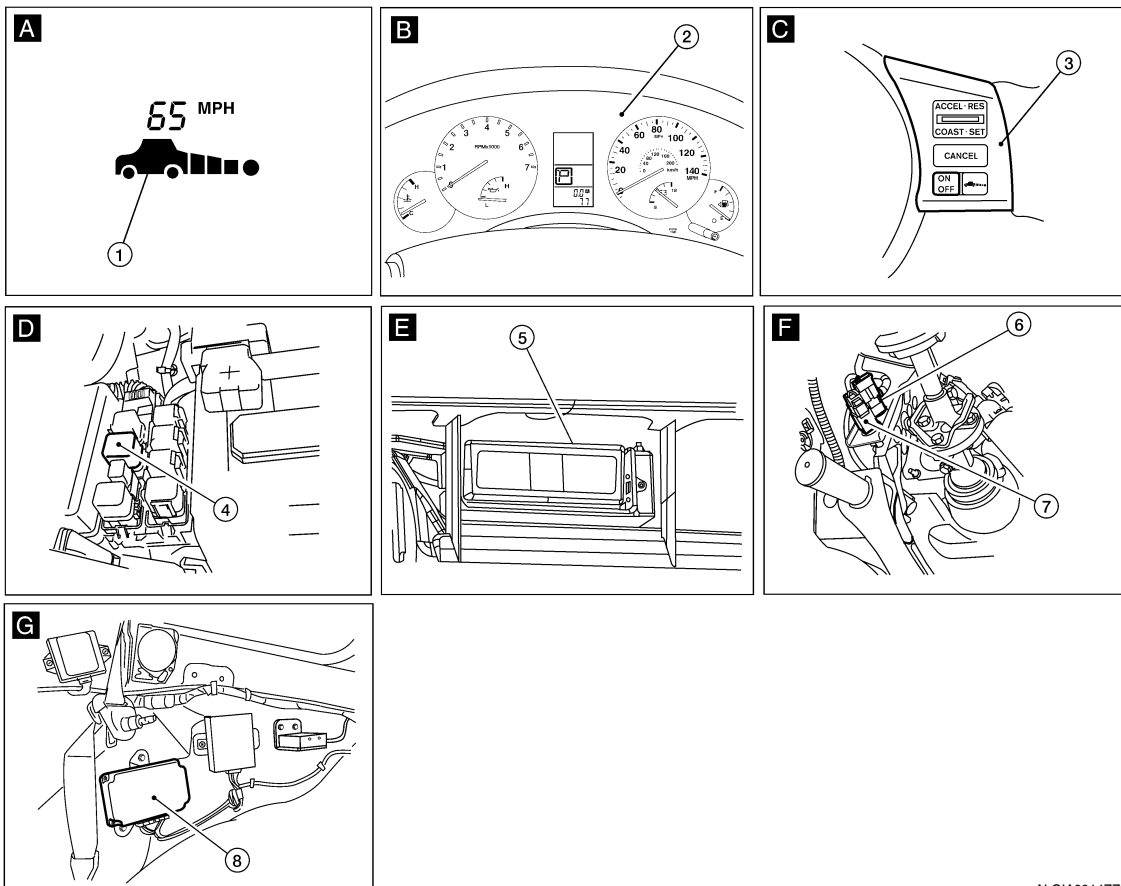
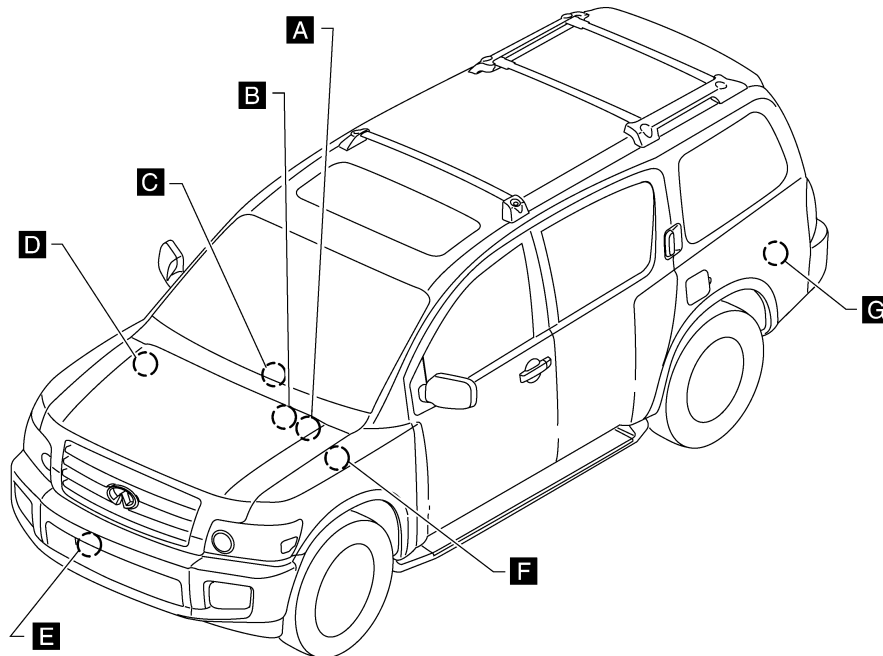

- | | | |
|------------------------------|---|-----------------------------|
| 1. ICC system display | 2. Combination meter M23, M24 (with built in information display) | 3. ICC steering switch M102 |
| 4. ICC brake hold relay E134 | 5. ICC sensor E42 | 6. ICC brake switch E43 |
| 7. Stop lamp switch E38 | 8. ICC unit B13, B17 (view with luggage side finisher lower LH removed) | |

ALOIA0014ZZ

A
B
C
D
E
F
G
H
I
J
K
L
M
N
P

CCS

INTELLIGENT CRUISE CONTROL SYSTEM

< FUNCTION DIAGNOSIS >

Component Description

INFOID:000000005145982

×: Applicable

Component	Vehicle-to-vehicle distance control mode	Conventional (Fixed speed) cruise control mode	Brake assist (With preview function)	Description
ICC unit	×	×	×	Controls vehicle speed through ECM via CAN communication.
ICC sensor	×	×	×	Measures distance to objects in front of the vehicle and transmits that information to the ICC unit.
ECM	×	×	×	Refer to EC-21, "System Diagram" .
ABS actuator and electric unit (control unit)	×	×	×	Refer to BRC-17, "System Description" .
Brake pressure sensor	×		×	Detects brake fluid pressure.
Brake booster	×		×	Adjusts brake fluid pressure based on command from ABS actuator and electric unit (control unit).
BCM	×			Transmits front wiper request signal to ICC sensor integrated unit through CAN communication.
TCM	×	×		Refer to TM-20, "TCM Function" .

DIAGNOSIS SYSTEM (ICC SENSOR INTEGRATED UNIT)

< FUNCTION DIAGNOSIS >

DIAGNOSIS SYSTEM (ICC SENSOR INTEGRATED UNIT)

Diagnosis Description

INFOID:000000005145983

The ICC system includes the on board self-diagnosis function that allows the technician to check for any trouble codes on the ICC system display by operating the ICC steering switch.

ON BOARD SELF-DIAGNOSIS OPERATION PROCEDURE

1. Turn ignition switch OFF.
2. Start engine.
3. From 5 seconds through 15 seconds after start engine, press RESUME/ACCELERATE switch 5 times, and SET/COAST switch 5 times.

NOTE:

- Never turn the MAIN switch ON.
- When operation above is not completed from 5 seconds through 15 seconds, start again from above go to 1.

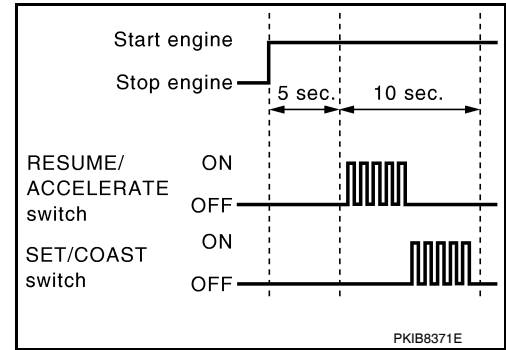

4. When the on board self-diagnosis starts up, the ICC system display shows DTC No. (1) at the set vehicle speed indicator. Refer to [CCS-56, "Diagnostic Trouble Code \(DTC\) Chart"](#).

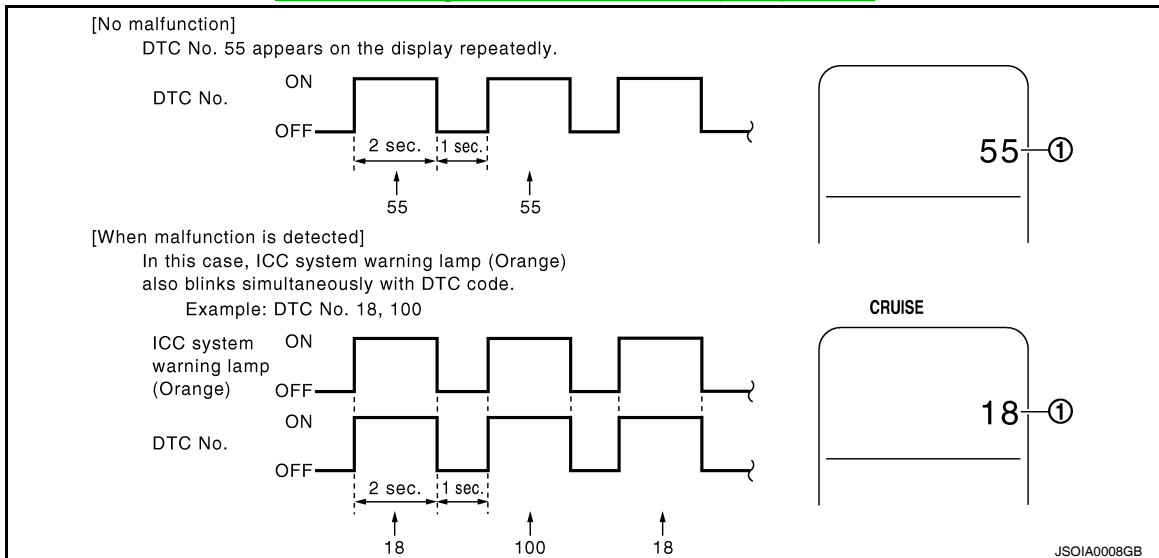

NOTE:

- DTC will disappear after 5 minutes.
- When more than one malfunction is detected, a maximum of 3 code numbers can be stored; the latest malfunction will be displayed first.

WHEN ON BOARD SELF-DIAGNOSIS WILL NOT START UP

If the on board self-diagnosis does not start up, check the following items.

Assumed abnormal point	Inspection item
ICC steering switch malfunction.	Perform the inspection for DTC 46 OPERATION SW CIRC. Refer to CCS-30, "DTC 46 OPERATION SW CIRC" .
Harness malfunction between ICC steering switch and ECM.	
ECM malfunction.	
ICC unit malfunction.	<ul style="list-style-type: none"> • Inspect the ICC sensor power and ground circuits. Refer to CCS-25, "DTC 31 POWER SUPPLY CIR1, DTC 34 POWER SUPPLY CIR2" • Perform the self-diagnosis for the ICC unit with CONSULT-III, and check the diagnosis results. Refer to CCS-56, "Diagnostic Trouble Code (DTC) Chart".

DIAGNOSIS SYSTEM (ICC SENSOR INTEGRATED UNIT)

< FUNCTION DIAGNOSIS >

ERASING ON BOARD SELF-DIAGNOSIS

1. Stop the vehicle and turn ignition switch OFF.
2. Start engine and start on board self-diagnosis.
3. During on board self-diagnosis, press CANCEL switch 5 times, and DISTANCE switch 5 times in this order.

NOTE:

- Press them within 10 seconds after pressing CANCEL switch at first.
- When operation is not completed within 10 seconds, start again from step 2 above.

4. DTC 55 will be shown.

NOTE:

DTC of an existing malfunction will not be erased.

5. Turn ignition switch OFF to exit the diagnosis.

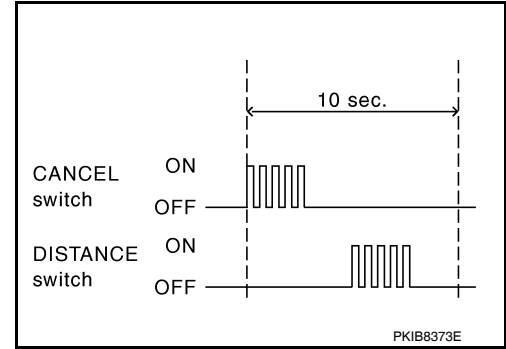

CONSULT-III Function (ICC)

INFOID:000000005145984

DESCRIPTION

CONSULT-III can display each diagnostic item using the diagnostic test modes shown following.

Test mode	Function
Work Support	<ul style="list-style-type: none"> • Monitors aiming direction to facilitate laser beam aiming operation. • Indicates causes of automatic cancellation of the ICC system.
Self Diagnostic Result	Displays malfunctioning system memorized in ICC sensor integrated unit.
Data Monitor	Displays real-time input/output data of ICC sensor integrated unit.
Active Test	Enables operation check of electrical loads by sending driving signal to them.
ECU Identification	Displays part number of ICC sensor integrated unit.

WORK SUPPORT

Work support item	Function
CAUSE OF AUTO-CANCEL	Indicates causes of automatic cancellation of the ICC system.
LASER BEAM ADJUST	Outputs laser beam, calculates dislocation of the beam, and indicates adjustment direction. For the adjustment procedure, refer to CCS-5, "ADDITIONAL SERVICE WHEN REPLACING CONTROL UNIT : Special Repair Requirement" .

Cause of Auto-Cancel Display Item List

×: Applicable

Cause of cancellation	Vehicle-to-vehicle distance control mode	Conventional (fixed speed) cruise control mode	Description
OPERATING WIPER	×		Windshield wipers were operated at HI or LO speed operation.
OPERATING ABS	×		ABS function was operated.
OPERATING TCS	×	×	TCS function was operated.
OPERATING VDC	×	×	VDC function was operated.
OPE SW VOLT CIRC	×	×	Outside the standard control switch input voltage was detected.
ECM CIRCUIT	×	×	ECM did not permit ICC operation.
LASER SUN BEAM	×		Intense light such as sunlight entered ICC sensor integrated unit light sensing part.
LASER TEMP	×		Temperature around ICC sensor integrated unit became low.
OP SW DOUBLE TOUCH	×	×	ICC steering switches were pressed at the same time.
WHL SPD ELEC NOISE	×	×	Wheel speed sensor signal caught electromagnetic noise.

DIAGNOSIS SYSTEM (ICC SENSOR INTEGRATED UNIT)

< FUNCTION DIAGNOSIS >

VDC/TCS OFF SW	×		VDC OFF switch was pressed.
WHEEL SPD UNMATCH	×	×	Wheel speed became different from A/T vehicle speed.
TIRE SLIP	×	×	Wheel slipped.
IGN LOW VOLT	×	×	Power supply voltage became low.
NO RECORD	×	×	—

- Last five cancel (system cancel) causes are displayed.
- “CAUSE OF AUTO-CANCEL” displays times of ignition switch ON/OFF up to 254 maximum. 254 is kept though the number exceeds 254. The number returns to 0 when detecting the same cancellation causes.

SELF DIAGNOSTIC RESULT

For details, refer to [CCS-56, "Diagnostic Trouble Code \(DTC\) Chart"](#).

NOTE:

“DTC RESULTS” and “TIME” are indicated on “Self Diagnostic Result”. “TIME” is used as a reference data of diagnosis. It shows when malfunction is detected.

“TIME” shows the following.

- 0: malfunction is detected at present (from malfunction detection to ignition switch OFF).
CAN communication ([U1000], [U1010])
- 1 ~ 39: Displays when it is normal at present and finds malfunction in the past. It increases like 0→1→2...38→39 after returning to the normal condition whenever IGN OFF→ON. If it is over 39, it is fixed to 39 until the self-diagnostic results are erased. It returns to 0 when malfunction is detected again in the process.
Other than CAN communication (other than [U1000], [U1010])
- 1 ~ 49: Displays when it is normal at present and finds malfunction in the past. It increases like 0→1→2...48→49 after returning to the normal condition whenever IGN OFF→ON. If it is over 49, it is fixed to 49 until the self-diagnostic results are erased. It returns to 0 when malfunction is detected again in the process.

DATA MONITOR

×: Applicable

Monitored Item [unit]	MAIN SIGNALS	SELECTION FROM MENU	Description
VHCL SPEED SE [km/h] or [mph]	×	×	Indicates vehicle speed calculated from ICC sensor integrated unit through CAN communication [ABS actuator and electric unit (control unit) transmits vehicle speed signal (wheel speed) through CAN communication].
SET VHCL SPD [km/h] or [mph]	×	×	Indicates set vehicle speed memorized in ICC sensor integrated unit.
THRTL OPENING [%]	×	×	Indicates throttle position read from ICC sensor integrated unit through CAN communication (ECM transmits accelerator pedal position signal through CAN communication).
SET DISTANCE [SHOR/MID/LONG]	×	×	Indicates set distance memorized in ICC sensor integrated unit.
MAIN SW [On/Off]	×	×	Indicates [On/Off] status as judged from ICC steering switch signal (ECM transmits ICC steering switch signal through CAN communication).
SET/COAST SW [On/Off]	×	×	Indicates [On/Off] status as judged from ICC steering switch signal (ECM transmits ICC steering switch signal through CAN communication).
CANCEL SW [On/Off]	×	×	Indicates [On/Off] status as judged from ICC steering switch signal (ECM transmits ICC steering switch signal through CAN communication).
RESUME/ACC SW [On/Off]	×	×	Indicates [On/Off] status as judged from ICC steering switch signal (ECM transmits ICC steering switch signal through CAN communication).
DISTANCE SW [On/Off]		×	Indicates [On/Off] status as judged from ICC steering switch signal (ECM transmits ICC steering switch signal through CAN communication).
CRUISE OPE [On/Off]	×	×	Indicates whether controlling or not (ON means “controlling”).
BRAKE SW [On/Off]	×	×	Indicates [On/Off] status as judged from ICC brake switch signal (ECM transmits ICC brake switch signal through CAN communication).

DIAGNOSIS SYSTEM (ICC SENSOR INTEGRATED UNIT)

< FUNCTION DIAGNOSIS >

Monitored Item [unit]	MAIN SIGNALS	SELECTION FROM MENU	Description
STOP LAMP SW [On/Off]	×	×	Indicates [On/Off] status as judged from stop lamp switch signal (ECM transmits stop lamp switch signal through CAN communication).
CRUISE LAMP [On/Off]	×	×	Indicates [On/Off] status of MAIN switch indicator lamp output.
NP SW SIG [On/Off]	×	×	Indicates [On/Off] status as judged from transmission range switch signal (ECM transmits transmission range switch signal through CAN communication).
STP LMP DRIVE [On/Off]	×	×	Indicates [On/Off] status of ICC brake hold relay drive output.
PWR SUP MONI [V]	×	×	Indicates IGN voltage input by ICC sensor integrated unit.
IDLE SW [On/Off]		×	Indicates [On/Off] status of idle switch read from ICC sensor integrated unit through CAN communication (ECM transmits On/Off status through CAN communication).
OWN VHCL [On/Off]		×	Indicates [On/Off] status of own vehicle indicator output.
VHCL AHEAD [On/Off]		×	Indicates [On/Off] status of vehicle ahead detection indicator output.
ICC WARNING [On/Off]		×	Indicates [On/Off] status of ICC system warning lamp output.
BUZZER O/P [On/Off]		×	Indicates [On/Off] status of ICC warning chime output.
ENGINE RPM [rpm]		×	Indicates engine speed read from ICC sensor integrated unit through CAN communication (ECM transmits engine speed through CAN communication).
WIPER SW [OFF/LOW/HIGH]		×	Indicates wiper [OFF/LOW/HIGH] status (BCM transmits front wiper request signal through CAN communication).
D RANGE SW [On/Off]		×	Indicates [On/Off] status of "D" or "DS" or "M" positions read from ICC sensor integrated unit through CAN communication; ON when position "D" or "DS" or "M" (TCM transmits shift position indicator lamp signal through CAN communication).
NP RANGE SW [On/Off]		×	Indicates shift position indicator lamp signal read from ICC sensor integrated unit through CAN communication (TCM transmits shift position indicator lamp signal through CAN communication).
VHCL SPD AT [km/h] or [mph]		×	Indicates vehicle speed calculated from A/T vehicle speed sensor read from ICC sensor integrated unit through CAN communication (TCM transmits A/T vehicle speed sensor signal through CAN communication).
GEAR [1, 2, 3, 4, 5]		×	Indicates A/T gear position read from ICC sensor integrated unit through CAN communication (TCM transmits current gear position signal through CAN communication).
MODE SIG [OFF, ICC, ASCD]		×	Indicates the active mode from ICC or ASCD [conventional (fixed speed) cruise control mode].
SET DISP IND [On/Off]		×	Indicates [On/Off] status of SET switch indicator output.
DISTANCE [m]		×	Indicates the distance from the vehicle ahead.
RELATIVE SPD [m/s]		×	Indicates the relative speed of the vehicle ahead.

ACTIVE TEST

DIAGNOSIS SYSTEM (ICC SENSOR INTEGRATED UNIT)

< FUNCTION DIAGNOSIS >

Active test item	Function	
ICC BUZZER	Activates/deactivates the ICC buzzer.	A
METER LAMP	Turns ON/OFF the MAIN switch indicator and ICC system warning lamp. NOTE: Start the engine and perform active test.	B
STOP LAMP	Drives the ICC brake hold relay and turns ON/OFF the stop lamp.	C

NOTE:

- Never perform the active test while driving.
- “Active Test” cannot be started while ICC system warning lamp illuminates.

ECU IDENTIFICATION

Displays the part number of the ICC sensor integrated unit.

A
B
C
D
E
F
G
H
I
J
K
L
M
N
P

CCS

DTC 11 CONTROL UNIT

< COMPONENT DIAGNOSIS >

COMPONENT DIAGNOSIS

DTC 11 CONTROL UNIT

DTC 11 CONTROL UNIT

INFOID:000000005145985

1. DIAGNOSTIC CHECK

Perform self diagnosis of the ICC system.

Are any items other than "DTC 11 CONTROL UNIT" indicated on self-diagnosis display?

- YES >> Repair or replace as necessary. Erase DTC and perform ICC system running test. Refer to [CCS-8, "ACTION TEST : ICC System Running Test"](#).
- NO >> Replace ICC unit. Refer to [CCS-71, "ICC Unit"](#). Erase DTC and perform ICC system running test. Refer to [CCS-8, "ACTION TEST : ICC System Running Test"](#).

DTC 12 VDC CONTROL UNIT

< COMPONENT DIAGNOSIS >

DTC 12 VDC CONTROL UNIT

DTC 12 VDC CONTROL UNIT

INFOID:000000005145986

Regarding Wiring Diagram information, refer to [CCS-48, "Wiring Diagram"](#).

1. DIAGNOSIS CHECK

Perform self-diagnosis of ABS actuator and electric unit (control unit).

Is malfunction indicated?

YES >> Repair or replace as necessary. Erase DTC and perform ICC system running test. Refer to [CCS-8, "ACTION TEST : ICC System Running Test"](#).

NO >> GO TO 2

2. CHECK CONNECTOR ICC UNIT AND ABS ACTUATOR AND ELECTRIC UNIT (CONTROL UNIT)

1. Turn ignition switch OFF.
2. Disconnect ICC unit, and ABS actuator and electric unit (control unit) connectors, and connect them securely again. Erase DTC, then perform self-diagnosis of ICC system again.

Does the DTC return?

YES >> Poor connector connection. Check connector housing for disconnected, loose, bent and collapsed terminals. If any malfunction is detected, repair as necessary. Erase DTC and perform ICC system running test. Refer to [CCS-8, "ACTION TEST : ICC System Running Test"](#).

NO >> GO TO 3

3. CHECK HARNESS BETWEEN ICC UNIT AND ABS ACTUATOR AND ELECTRIC UNIT (CONTROL UNIT)

1. Turn ignition switch OFF.
2. Disconnect ICC unit and ABS actuator and electric unit (control unit) connectors.
3. Check continuity between ICC unit harness connector B13 terminal 10, and ABS actuator and electric unit (control unit) connector E125 terminal 7.

Continuity should exist.

Does continuity exist?

YES >> Replace ICC unit. Refer to [CCS-71, "ICC Unit"](#). Erase DTC and perform ICC system running test. Refer to [CCS-8, "ACTION TEST : ICC System Running Test"](#).

NO >> • Repair harness between ICC unit, and ABS actuator and electric unit (control unit).
• Erase DTC and perform ICC system running test. Refer to [CCS-8, "ACTION TEST : ICC System Running Test"](#).

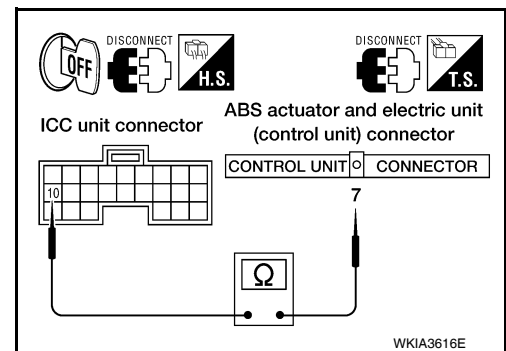

DTC 20 CAN COMM CIRCUIT

< COMPONENT DIAGNOSIS >

DTC 20 CAN COMM CIRCUIT

DTC 20 CAN COMM CIRCUIT

INFOID:000000005145987

1. CHECK CAN COMMUNICATION

1. Perform self-diagnosis.

>> GO TO "CAN system". Refer to [LAN-4, "System Description"](#).

DTC 31 POWER SUPPLY CIR1, DTC 34 POWER SUPPLY CIR2

< COMPONENT DIAGNOSIS >

DTC 31 POWER SUPPLY CIR1, DTC 34 POWER SUPPLY CIR2

DTC 31 POWER SUPPLY CIR1, DTC 34 POWER SUPPLY CIR2

INFOID:000000005145988

Regarding Wiring Diagram information, refer to [CCS-48, "Wiring Diagram"](#).

1. CHECK ICC UNIT CONNECTOR

1. Turn ignition switch OFF.
2. Disconnect ICC unit connectors and connect them securely again. Erase DTC, then perform self-diagnosis of ICC system again.

Does the DTC reset?

YES >> GO TO 2

NO >> • Poor connector connection.

- Check connector. Check connector housing for disconnected, loose, bent, and collapsed terminals. If any malfunction is detected, repair as as necessary. Erase DTC and perform ICC system running test. Refer to [CCS-8, "ACTION TEST : ICC System Running Test"](#).

2. CHECK POWER SUPPLY CIRCUIT FOR ICC UNIT

1. Turn ignition switch ON.
2. Check voltage between ICC unit harness connector B17 terminals 33, 42 and ground.

Battery voltage should exist.

Does battery voltage exist?

YES >> GO TO 3

NO >> • Repair ICC unit power supply harness.

- Erase DTC and perform ICC system running test. Refer to [CCS-8, "ACTION TEST : ICC System Running Test"](#).

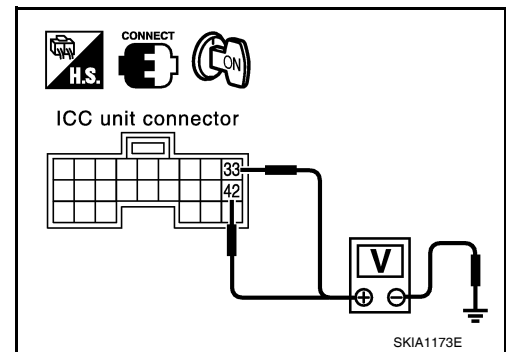

3. CHECK GROUND CIRCUIT FOR ICC UNIT

1. Turn ignition switch OFF.
2. Disconnect ICC unit connectors.
3. Check continuity between ICC unit harness connector B13 terminals 19, 20, and connector B17 terminal 46 and ground.

Continuity should exist.

Does continuity exist?

YES >> Replace ICC unit. Refer to [CCS-71, "ICC Unit"](#). Erase DTC and perform ICC system running test. Refer to [CCS-8, "ACTION TEST : ICC System Running Test"](#).

NO >> • Repair ICC unit ground harness.

- Erase DTC and perform ICC system running test. Refer to [CCS-8, "ACTION TEST : ICC System Running Test"](#).

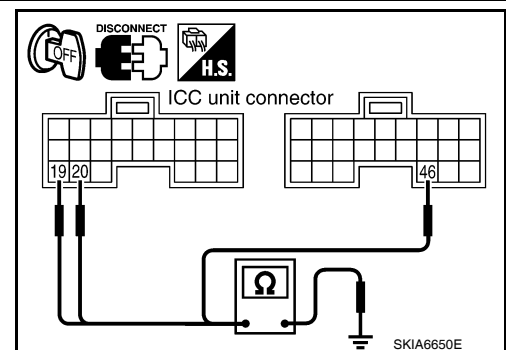

A
B
C
D
E
F
G
H
I
J
K
L
M
N
P

DTC 41 VHCL SPEED SE CIRC

< COMPONENT DIAGNOSIS >

DTC 41 VHCL SPEED SE CIRC

DTC 41 VHCL SPEED SE CIRC

INFOID:000000005145989

1. PERFORM ICC UNIT SELF-DIAGNOSIS

Perform self-diagnosis.

Is "DTC 43 VDC/TCS/ABS CIRC" or "DTC 20 CAN COMM CIRCUIT" indicated in self-diagnosis item display?

YES >> Repair or replace as necessary. Erase DTC and perform ICC system running test. Refer to [CCS-8, "ACTION TEST : ICC System Running Test"](#).

NO >> GO TO 2

2. CHECK A/T VEHICLE SPEED SENSOR

With data monitor, check "VHCL SPD AT".

Does the data monitor item work normally?

YES >> Replace ICC unit. Refer to [CCS-71, "ICC Unit"](#). Erase DTC and perform ICC system running test. Refer to [CCS-8, "ACTION TEST : ICC System Running Test"](#).

NO >> • Check TCM.
• Erase DTC and perform ICC system running test. Refer to [CCS-8, "ACTION TEST : ICC System Running Test"](#).

DTC 43 VDC/TCS/ABS CIRC

< COMPONENT DIAGNOSIS >

DTC 43 VDC/TCS/ABS CIRC

DTC 43 VDC/TCS/ABS CIRC

INFOID:000000005145990

1. DIAGNOSIS CHECK 1

Perform self-diagnosis.

Is "CAN COMM CIRCUIT" indicated?

YES >> Repair or replace as necessary. Erase DTC and perform ICC system running test. Refer to [CCS-8, "ACTION TEST : ICC System Running Test"](#).

NO >> GO TO 2

2. DIAGNOSIS CHECK 2

Perform self-diagnosis of ABS actuator and electric unit (control unit).

Is malfunction indicated?

YES >> Repair the ABS system as necessary. Erase DTC and perform ICC system running test. Refer to [CCS-8, "ACTION TEST : ICC System Running Test"](#).

NO >> Replace ICC unit. Refer to [CCS-71, "ICC Unit"](#). Erase DTC and perform ICC system running test. Refer to [CCS-8, "ACTION TEST : ICC System Running Test"](#).

A
B
C
D
E
F
G
H
I
J
K
L
M
N
P

CCS

DTC 45 BRAKE SW/STOP L SW

< COMPONENT DIAGNOSIS >

DTC 45 BRAKE SW/STOP L SW

DTC 45 BRAKE SW/STOP L SW

INFOID:000000005145991

Regarding Wiring Diagram information, refer to [CCS-48, "Wiring Diagram"](#).

1. CHECK CONNECTORS FOR ICC UNIT

1. Turn ignition switch OFF.
2. Disconnect ICC unit connectors and connect them securely again. Erase DTC, then perform self-diagnosis of ICC system again.

Does the DTC reset?

- YES >> • Poor connector connection.
• Check connectors. Check connectors housing for disconnected, loose, bent, and collapsed terminals. If any malfunction is detected, repair as necessary. Erase DTC and perform ICC system running test. Refer to [CCS-8, "ACTION TEST : ICC System Running Test"](#).
- NO >> GO TO 2

2. CHECK STOP LAMP SWITCH AND ICC BRAKE SWITCH

With data monitor, check if "STOP LAMP SW" and "BRAKE SW" are operating normally.

Do the monitor items display properly?

- YES >> Replace ICC unit. Refer to [CCS-71, "ICC Unit"](#). Erase DTC and perform ICC system running test. Refer to [CCS-8, "ACTION TEST : ICC System Running Test"](#).
- NO >> • BRAKE SW: GO TO 3
• STOP LAMP SW: GO TO 5

3. ICC BRAKE SWITCH INSTALLATION AND ADJUSTMENT INSPECTION

Check ICC brake switch for proper installation and adjust if necessary.

Does ICC brake switch operate normally?

- YES >> GO TO 4
- NO >> After adjustment, erase DTC and perform ICC system running test. Refer to [CCS-8, "ACTION TEST : ICC System Running Test"](#).

4. CHECK ICC BRAKE SWITCH

Check ICC brake switch.

Does the ICC brake switch check OK?

- YES >> Replace ICC unit. Refer to [CCS-71, "ICC Unit"](#). Erase DTC and perform ICC system running test. Refer to [CCS-8, "ACTION TEST : ICC System Running Test"](#).
- NO >> Replace ICC brake switch. Erase DTC and perform ICC system running test. Refer to [CCS-8, "ACTION TEST : ICC System Running Test"](#).

5. CHECK STOP LAMP ILLUMINATION

Check stop lamp illumination.

Do the stop lamps operate normally?

- YES >> GO TO 6
- NO >> • Check stop lamp circuit.
• Erase DTC and perform ICC system running test. Refer to [CCS-8, "ACTION TEST : ICC System Running Test"](#).

6. CHECK ICC BRAKE HOLD RELAY

DTC 45 BRAKE SW/STOP L SW

< COMPONENT DIAGNOSIS >

1. Turn ignition switch OFF.
2. Remove ICC brake hold relay.
3. Check continuity between ICC brake hold relay terminals.

7 - 6 Continuity should not exist.

4 - 3 Continuity should exist.

Are continuity results as specified?

YES >> GO TO 7

NO >> Replace ICC brake hold relay. Erase DTC and perform ICC system running test. Refer to [CCS-8, "ACTION TEST : ICC System Running Test"](#).

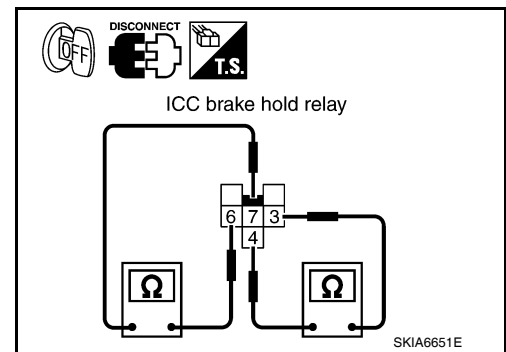

7. CHECK ICC BRAKE HOLD RELAY CIRCUIT

1. Disconnect ICC unit and stop lamp switch connectors.
2. Check continuity between ICC unit harness connector (A) B17 terminal 38 and ICC brake hold relay harness connector (B) E134 terminal 6.

Continuity should exist.

3. Check continuity between ICC unit harness connector (A) B17 terminal 38 and stop lamp switch harness connector (C) E38 terminal 4.

Continuity should exist.

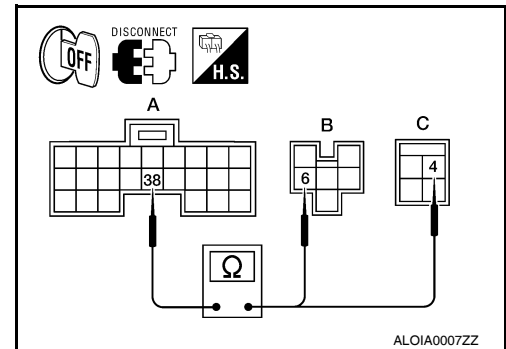

Are continuity test results as specified?

YES >> Replace ICC unit. Refer to [CCS-71, "ICC Unit"](#). Erase DTC and perform ICC system running test. Refer to [CCS-8, "ACTION TEST : ICC System Running Test"](#).

NO >> • Repair harness between ICC unit and ICC brake hold relay or stop lamp switch.
• Erase DTC and perform ICC system running test. Refer to [CCS-8, "ACTION TEST : ICC System Running Test"](#).

DTC 46 OPERATION SW CIRC

< COMPONENT DIAGNOSIS >

DTC 46 OPERATION SW CIRC

DTC 46 OPERATION SW CIRC

INFOID:000000005145992

Regarding Wiring Diagram information, refer to [CCS-48, "Wiring Diagram"](#).

1. CHECK ECM CONNECTOR

1. Turn ignition switch OFF.
2. Disconnect ECM connector and connect it securely again. Erase DTC, then perform self-diagnosis of ICC system again.

Does the DTC reset?

- YES >> • Poor connector connection.
• Check connector. Check connector housing for disconnected, loose, bent, and collapsed terminals. If any malfunction is detected, repair as as necessary. Erase DTC and perform ICC system running test. Refer to [CCS-8, "ACTION TEST : ICC System Running Test"](#).

NO >> GO TO 2

2. CHECK ICC STEERING SWITCH

Check ICC steering switch.

Does the ICC steering switch check OK?

YES >> GO TO 3

- NO >> Replace ICC steering switch assembly. Refer to [CCS-73, "Removal and Installation"](#). Erase DTC and perform ICC system running test. Refer to [CCS-8, "ACTION TEST : ICC System Running Test"](#).

3. CHECK ICC STEERING SWITCH SIGNAL CIRCUIT

1. Turn ignition switch OFF.
2. Disconnect ECM and spiral cable connectors.
3. Check continuity between ECM harness connectors E16 and F54 terminals 67, 99 and spiral cable harness connector M30 terminals 33, 34.

67 - 33, 99 - 34

Continuity should exist.

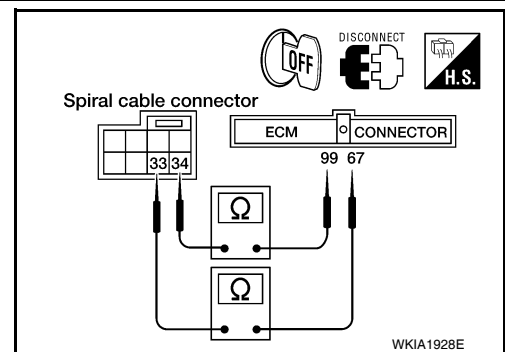

Does continuity exist?

YES >> GO TO 4

- NO >> • Repair harness between ECM and spiral cable.
• Erase DTC and perform ICC system running test. Refer to [CCS-8, "ACTION TEST : ICC System Running Test"](#).

4. CHECK ICC STEERING SWITCH SIGNAL CIRCUIT

1. Disconnect remaining spiral cable connector.
2. Check continuity between spiral cable (A) (to vehicle) terminals 33, 34 and spiral cable (B) (to switch) terminals 14, 15.

34 - 14, 33 - 15

Continuity should exist.

Does continuity exist?

- YES >> Replace ECM. Erase DTC and perform ICC system running test. Refer to [CCS-8, "ACTION TEST : ICC System Running Test"](#).

- NO >> • Replace spiral cable. Refer to [SR-7, "Removal and Installation"](#).

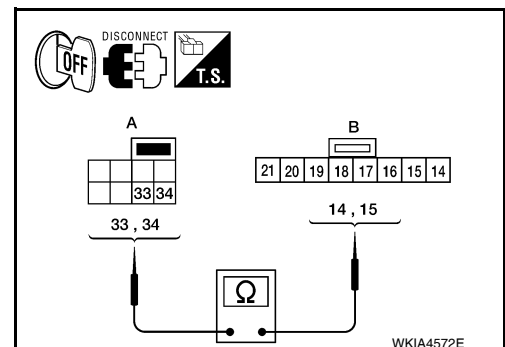

DTC 46 OPERATION SW CIRC

< COMPONENT DIAGNOSIS >

- Erase DTC and perform ICC system running test. Refer to [CCS-8. "ACTION TEST : ICC System Running Test"](#).

A

B

C

D

E

F

G

H

I

J

K

L

M

N

CCS

P

DTC 74 LASER BEAM OFF CNTR

< COMPONENT DIAGNOSIS >

DTC 74 LASER BEAM OFF CNTR

DTC 74 LASER BEAM OFF CNTR

INFOID:000000005145993

1. DIAGNOSTIC CHECK

1. Adjust laser beam aiming. Refer to [CCS-5, "LASER BEAM AIMING ADJUSTMENT : Outline of Laser Beam Aiming Adjustment Procedure"](#). Erase DTC and perform ICC system running test. Refer to [CCS-8, "ACTION TEST : ICC System Running Test"](#) .
2. Perform self-diagnosis of ICC system.

Is DTC 74 LASER BEAM OFF CNTR incicated?

- YES >> • Replace ICC sensor and adjust laser beam aiming. Refer to [CCS-72, "ICC Sensor"](#) .
• Erase DTC and perform ICC system running test. Refer to [CCS-8, "ACTION TEST : ICC System Running Test"](#).
- NO >> Inspection end.

DTC 90 STOP LAMP RLY FIX

< COMPONENT DIAGNOSIS >

DTC 90 STOP LAMP RLY FIX

DTC 90 STOP LAMP RLY FIX

INFOID:000000005145994

Regarding Wiring Diagram information, refer to [CCS-48, "Wiring Diagram"](#).

1. CHECK ICC UNIT CONNECTOR

1. Turn ignition switch OFF.
2. Disconnect and check ICC unit connector.

Does connector check OK?

- YES >> GO TO 2
NO >> • Connector malfunction.
• Erase DTC and perform ICC system running test. Refer to [CCS-8, "ACTION TEST : ICC System Running Test"](#).

2. CHECK STOP LAMP SWITCH AND ICC BRAKE SWITCH

1. Connect ICC unit connector and turn ignition switch ON.
2. With data monitor, check that "STOP LAMP SW" and "BRAKE SW" operate normally.

Do the monitor items display normally?

- YES >> GO TO 11
NO >> • BRAKE SW: GO TO 3
• STOP LAMP SW: GO TO 8

3. CHECK AND ADJUST ICC BRAKE SWITCH

Check ICC brake switch for proper installation and adjust if necessary.

Does the ICC brake switch pass inspection?

- YES >> GO TO 4
NO >> After adjustment, erase DTC and perform ICC system running test. Refer to [CCS-8, "ACTION TEST : ICC System Running Test"](#).

4. CHECK ICC BRAKE SWITCH

Check ICC brake switch. Refer to [CCS-28, "DTC 45 BRAKE SW/STOP L SW"](#).

Is the ICC brake switch operating normally?

- YES >> GO TO 5
NO >> Replace ICC brake switch. Erase DTC and perform ICC system running test. Refer to [CCS-8, "ACTION TEST : ICC System Running Test"](#).

5. CHECK ICC BRAKE HOLD RELAY

Disconnect ICC brake hold relay and check continuity between ICC brake hold relay terminal 4 and terminal 3.

Continuity should exist.

Does continuity exist?

- YES >> GO TO 6
NO >> Replace ICC brake hold relay. Erase DTC and perform ICC system running test. Refer to [CCS-8, "ACTION TEST : ICC System Running Test"](#).

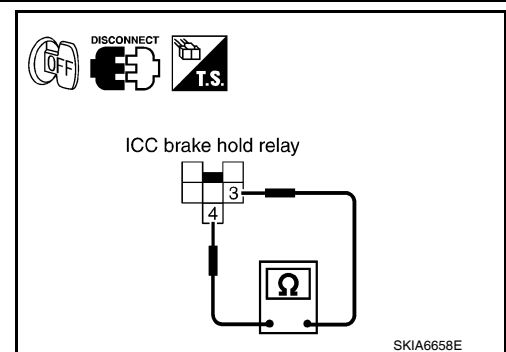

6. CHECK HARNESS THROUGH ICC BRAKE HOLD RELAY, ICC BRAKE SWITCH, ICC UNIT

1. Disconnect ECM and ICC unit harness connectors.

DTC 90 STOP LAMP RLY FIX

< COMPONENT DIAGNOSIS >

2. Check continuity between ICC brake hold relay harness connector (B) E134 terminal 3 and ICC unit harness connector (A) B17 terminal 29.

Continuity should exist.

3. Check continuity between ICC unit harness connector (A) B17 terminal 29 and ground.

Continuity should not exist.

Are continuity test results as specified?

YES >> GO TO 7

NO >> • Repair harness between ICC brake hold relay and ICC brake switch.

• Repair harness between ICC brake switch and ICC unit.

• Erase DTC and perform ICC system running test. Refer to [CCS-8, "ACTION TEST : ICC System Running Test"](#).

7.CHECK ICC BRAKE HOLD RELAY POWER SUPPLY CIRCUIT

1. Turn ignition switch ON.
2. Check voltage between ICC brake hold relay harness connector E134 terminal 4 and ground.

Battery voltage should exist

Does battery voltage exist?

YES >> Replace ICC unit. Refer to [CCS-71, "ICC Unit"](#). Erase DTC and perform ICC system running test. Refer to [CCS-8, "ACTION TEST : ICC System Running Test"](#).

NO >> • Check fuse or ICC brake hold relay power supply system harness.

• Erase DTC and perform ICC system running test. Refer to [CCS-8, "ACTION TEST : ICC System Running Test"](#).

8.CHECK STOP LAMP SWITCH

1. Turn ignition switch OFF.
2. Check stop lamp switch.

Does stop lamp switch operate normally?

YES >> GO TO 9

NO >> Replace stop lamp switch. Erase DTC and perform ICC system running test. Refer to [CCS-8, "ACTION TEST : ICC System Running Test"](#).

9.CHECK ICC BRAKE HOLD RELAY CIRCUIT

1. Disconnect stop lamp switch connector.
2. When brake pedal is not depressed, make sure that stop lamp does not illuminate.

Does the ICC brake hold relay check OK?

YES >> Replace ICC unit. Refer to [CCS-71, "ICC Unit"](#). Erase DTC and perform ICC system running test. Refer to [CCS-8, "ACTION TEST : ICC System Running Test"](#).

NO >> GO TO 10

10.CHECK ICC BRAKE HOLD RELAY

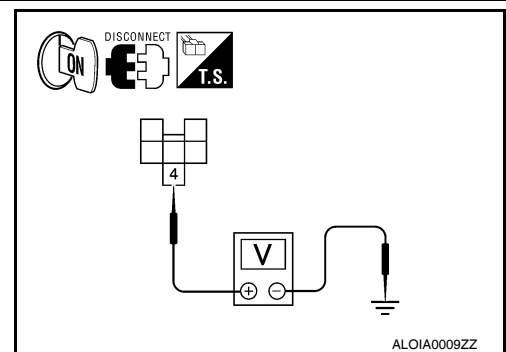
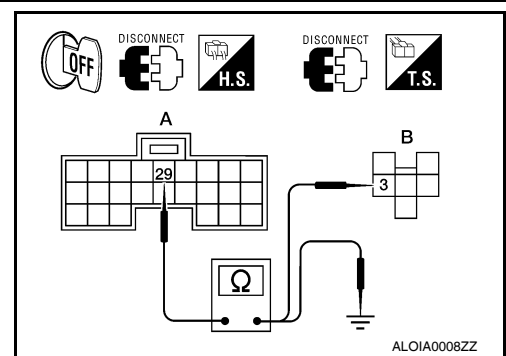

DTC 90 STOP LAMP RLY FIX

< COMPONENT DIAGNOSIS >

1. Disconnect ICC brake hold relay.
2. Check continuity between ICC brake hold relay E134 terminal 7 and terminal 6.

Continuity should not exist.

Are continuity test results as specified?

- YES >> Replace ICC unit. Refer to [CCS-71, "ICC Unit"](#). Erase DTC and perform ICC system running test. Refer to [CCS-8, "ACTION TEST : ICC System Running Test"](#).
- NO >> Replace ICC brake hold relay. Erase DTC and perform ICC system running test. Refer to [CCS-8, "ACTION TEST : ICC System Running Test"](#).

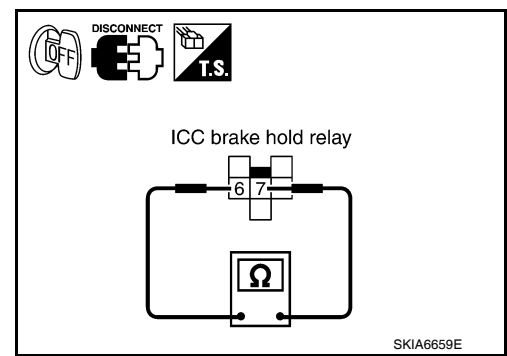

11. CHECK HARNESS THROUGH ICC UNIT, ICC BRAKE HOLD RELAY, AND GROUND

1. Disconnect ICC unit and ICC brake hold relay harness connectors.
2. Check continuity between ICC unit harness connector B17 terminal 47 and ICC brake hold relay harness connector E134 terminal 1.

47 - 1 Continuity should exist.

3. Check continuity between ICC unit harness connector B17 terminal 47 and ground.

47 - Ground Continuity should not exist.

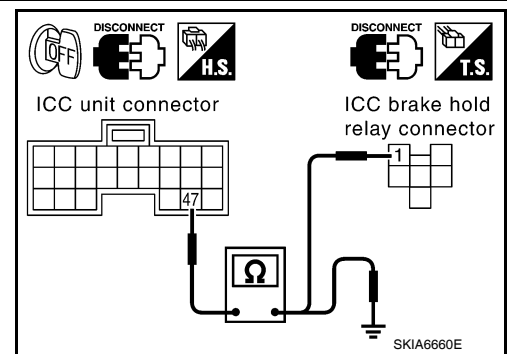

4. Check continuity between ICC brake hold relay harness connector E134 terminal 2 and ground.

Continuity should exist.

Are continuity test results as specified?

- YES >> GO TO 12
- NO >> • Repair harness through ICC unit and ICC brake hold relay, or between ICC brake hold relay and ground.
• Erase DTC and perform ICC system running test. Refer to [CCS-8, "ACTION TEST : ICC System Running Test"](#).

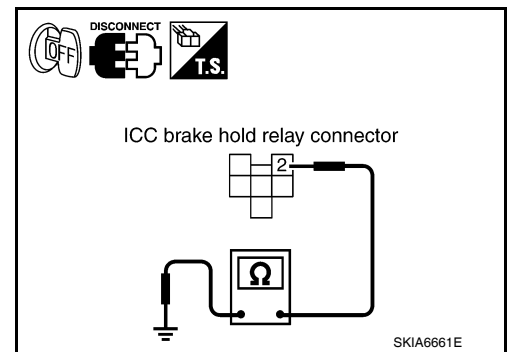

12. CHECK ICC BRAKE HOLD RELAY

- Check continuity between ICC brake hold relay terminal 1 and terminal 2.

Continuity should exist (minimal resistance through coil will exist)

Does continuity exist?

- YES >> GO TO 13
- NO >> Replace ICC brake hold relay. Erase DTC and perform ICC system running test. Refer to [CCS-8, "ACTION TEST : ICC System Running Test"](#).

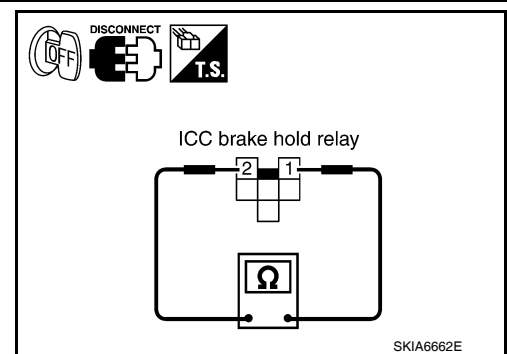

13. CHECK ICC UNIT STANDARD VOLTAGE

A
B
C
D
E
F
G
H
I
J
K
L
M
N
P

CCS

DTC 90 STOP LAMP RLY FIX

< COMPONENT DIAGNOSIS >

1. Connect connectors of ICC unit and stop lamp switch.
2. While performing active test (STOP LAMP: STP LMP DRIVE ON) with CONSULT-III, check voltage between ICC unit harness connector B17 terminal 47 and ground.

47 - Ground

**Battery voltage should exist
(during active test)**

Does battery voltage exist?

- YES >> GO TO 14
NO >> Replace ICC unit. Refer to [CCS-71, "ICC Unit"](#). Erase DTC and perform ICC system running test. Refer to [CCS-8, "ACTION TEST : ICC System Running Test"](#).

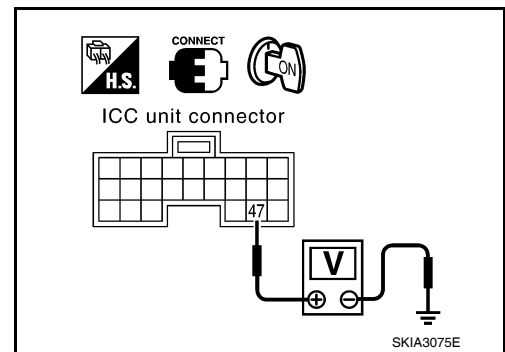

14. CHECK ICC BRAKE HOLD RELAY POWER SUPPLY CIRCUIT

Check voltage between ICC brake hold relay harness connector E134 terminal 7 and ground.

7 - Ground

Battery voltage should exist

Does battery voltage exist?

- YES >> GO TO 15
NO >> • Check fuse or ICC brake hold relay power supply harness.
• Erase DTC and perform ICC system running test. Refer to [CCS-8, "ACTION TEST : ICC System Running Test"](#).

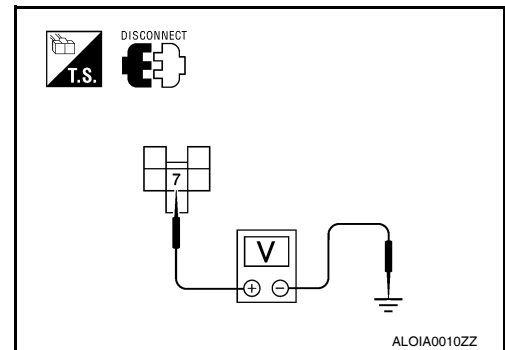

15. CHECK HARNESS BETWEEN ICC BRAKE HOLD RELAY AND ICC UNIT

1. Turn ignition switch OFF.
2. Disconnect ICC unit harness connectors.
3. Check continuity between ICC brake hold relay harness connector (B) E134 terminal 6 and ICC unit harness connector (A) B17 terminal 38.

6 - 38

Continuity should exist.

4. Check continuity between ICC unit harness connector (A) B17 terminal 38 and ground.

38 - Ground

Continuity should not exist.

Are continuity test results as specified?

- YES >> GO TO 16
NO >> • Repair harness between ICC brake hold relay and ICC unit or between ICC brake hold relay and stop lamp switch.
• Erase DTC and perform ICC system running test. Refer to [CCS-8, "ACTION TEST : ICC System Running Test"](#).

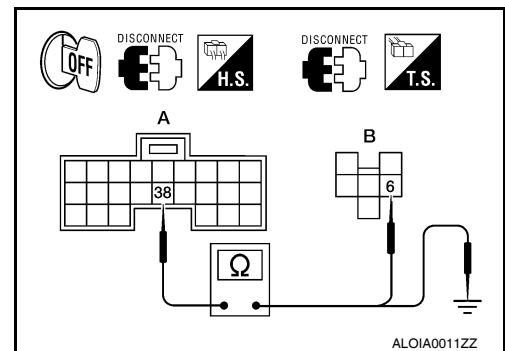

16. CHECK ICC BRAKE HOLD RELAY

1. Connect ICC unit and ICC brake hold relay harness connectors.
2. Disconnect stop lamp switch connector.
3. Perform active test (STOP LAMP) with CONSULT-III, and make sure that stop lamps are illuminated.

Do the stop lamps illuminate?

- YES >> GO TO 17
NO >> Replace ICC brake hold relay. Erase DTC and perform ICC system running test. Refer to [CCS-8, "ACTION TEST : ICC System Running Test"](#).

17. CHECK ICC UNIT STANDARD VOLTAGE

DTC 90 STOP LAMP RLY FIX

< COMPONENT DIAGNOSIS >

1. Connect stop lamp switch connector.
2. While performing active test (STOP LAMP: STP LMP DRIVE ON) with CONSULT-III, check voltage between ICC unit harness connector B17 terminal 29 and ground.

29 - Ground **Approx. 0V (during active test)**

Are voltage readings as specified?

- YES >> Replace ICC unit. Refer to [CCS-71, "ICC Unit"](#). Erase DTC and perform ICC system running test. Refer to [CCS-8, "ACTION TEST : ICC System Running Test"](#).
- NO >> Replace stop lamp switch. Erase DTC and perform ICC system running test. Refer to [CCS-8, "ACTION TEST : ICC System Running Test"](#).

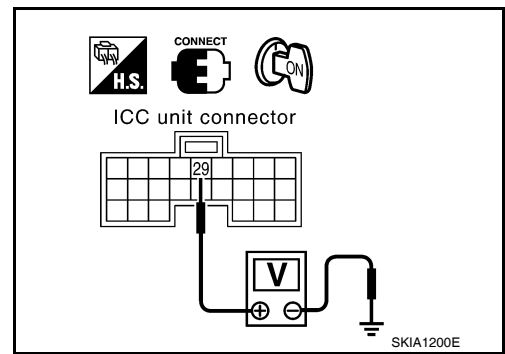

A
B
C
D
E
F
G
H
I
J
K
L
M
N
P

CCS

DTC 92 ECM CIRCUIT

< COMPONENT DIAGNOSIS >

DTC 92 ECM CIRCUIT

DTC 92 ECM CIRCUIT

INFOID:000000005145995

1. DIAGNOSIS CHECK 1

Perform self-diagnosis with CONSULT-III.

Is "CAN COMM CIRCUIT" indicated?

- YES >> Repair or replace as necessary. Erase DTC and perform ICC system running test. Refer to [CCS-8, "ACTION TEST : ICC System Running Test"](#) .
- NO >> GO TO 2

2. DIAGNOSIS CHECK 2

Perform ECM self-diagnosis.

Is malfunction indicated?

- YES >> Repair or replace as necessary. Erase DTC and perform ICC system running test. Refer to [CCS-8, "ACTION TEST : ICC System Running Test"](#).
- NO >> Replace ICC unit. Refer to [CCS-71, "ICC Unit"](#). Erase DTC and perform ICC system running test. Refer to [CCS-8, "ACTION TEST : ICC System Running Test"](#).

DTC 96 NP RANGE

< COMPONENT DIAGNOSIS >

DTC 96 NP RANGE

DTC 96 NP RANGE

INFOID:000000005145996

Regarding Wiring Diagram information, refer to [CCS-48, "Wiring Diagram"](#).

1. CHECK ICC UNIT CONNECTORS

1. Turn ignition switch OFF.
2. Disconnect ICC unit harness connectors and connect them securely again. Erase DTC, then perform self-diagnosis of ICC system again.

Does the DTC reset?

YES >> GO TO 2

NO >> • Poor connector connection.

- Check connector. Check connector housing for disconnected, loose, bent, and collapsed terminals. If any malfunction is detected, repair as necessary. Erase DTC and perform ICC system running test. Refer to [CCS-8, "ACTION TEST : ICC System Running Test"](#).

2. CHECK NP RANGE SWITCH SIGNAL

With data monitor, check that "NP RANGE SW" operates normally.

Does the "NP RANGE SW" monitor item operate normally?

YES >> Perform TCM diagnosis. Refer to [TM-30, "Introduction"](#).

NO >> GO TO 3

3. CHECK HARNESS BETWEEN ICC UNIT AND TCM

1. Turn ignition switch OFF.
2. Disconnect ICC unit harness connectors and A/T assembly harness connector.
3. Check continuity between ICC unit harness connector B13 terminal 7 and A/T assembly harness connector F9 terminal 9.

7 - 9

Continuity should exist.

Does continuity exist?

YES >> Replace ICC unit. Refer to [CCS-71, "ICC Unit"](#). Erase DTC and perform ICC system running test. Refer to [CCS-8, "ACTION TEST : ICC System Running Test"](#).

NO >> • Repair harness between ICC unit and TCM.

- Erase DTC and perform ICC system running test. Refer to [CCS-8, "ACTION TEST : ICC System Running Test"](#).

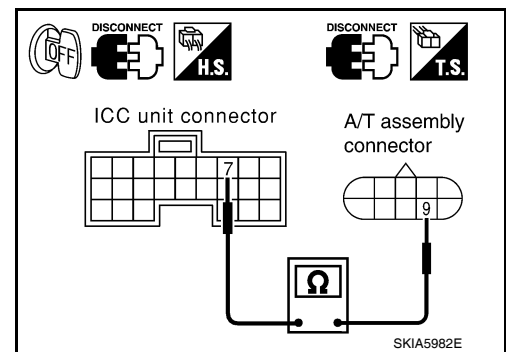

DTC 97 AT CIRCUIT

< COMPONENT DIAGNOSIS >

DTC 97 AT CIRCUIT

DTC 97 AT CIRCUIT

INFOID:000000005145997

1. CHECK A/T CIRCUIT

With TCM diagnosis, check that shift operates normally. Refer to [TM-20, "TCM Function"](#).

Is the transmission operating normally?

- YES >> Replace ICC unit. Refer to [CCS-71, "ICC Unit"](#).
- NO >> • Perform TCM diagnosis.
• Erase DTC and perform self-diagnosis of ICC system again.

DTC 98 GEAR POSITION

< COMPONENT DIAGNOSIS >

DTC 98 GEAR POSITION

DTC 98 GEAR POSITION

INFOID:000000005145998

1. DIAGNOSTIC CHECK

Perform ICC self diagnosis.

Does "DTC 43 VDC/TCS/ABS CIRC" or "DTC 41 VHCL SPEED SE CIRC" indicated in self-diagnosis display item?

- YES >> Repair or replace as necessary. Erase DTC and perform self-diagnosis of ICC system again.
- NO >> GO TO 2

2. CHECK VEHICLE SPEED SIGNAL

With data monitor, check that "VHCL SPEED SE" is normal.

Does the "VHCL SPEED SE" monitor item display normally?

- YES >> GO TO 3
- NO >> Replace ICC unit. Refer to [CCS-71, "ICC Unit"](#). Erase DTC and perform self-diagnosis of ICC system again.

3. CHECK GEAR SHIFT POSITION

Check that gear positions are correct in A/T.

Does the transmission operate normally?

- YES >> GO TO 5
- NO >> GO TO 4

4. CHECK TCM GEAR POSITION SIGNAL

With TCM data monitor, check that gear positions are correct.

Does the data monitor indicate proper gear positions?

- YES >> Replace ICC unit. Refer to [CCS-71, "ICC Unit"](#).
- NO >> • Perform TCM diagnosis.
 - Erase DTC and perform self-diagnosis of ICC system again.

5. CHECK TCM TURBINE ROTATION

With TCM diagnosis, check that turbine rpm is normal. Refer to [TM-48, "Description"](#).

Does the TCM check OK?

- YES >> Replace ICC unit. Refer to [CCS-71, "ICC Unit"](#).
- NO >> • Perform TCM diagnosis.
 - Erase DTC and perform self-diagnosis of ICC system again. Refer to [CCS-17, "Diagnosis Description"](#).

A
B
C
D
E
F
G
H
I
J
K
L
M
N
P



DTC 102 LASER STAIN

< COMPONENT DIAGNOSIS >

DTC 102 LASER STAIN

DTC 102 LASER STAIN

INFOID:000000005145999

1.VISUAL INSPECTION (1)

Check that there is no contamination and foreign material on ICC sensor body window.

Is the ICC sensor clean?

YES >> GO TO 2

NO >> • Clean ICC sensor.

- Erase DTC and perform ICC system running test. Refer to [CCS-8, "ACTION TEST : ICC System Running Test"](#).

2.VISUAL INSPECTION (2)

Check ICC sensor body window for cracks.

Is the ICC sensor window undamaged?

YES >> GO TO 3

NO >> • Replace ICC sensor and adjust laser beam. Refer to [CCS-72, "ICC Sensor"](#).

- Erase DTC and perform ICC system running test. Refer to [CCS-8, "ACTION TEST : ICC System Running Test"](#).

3.ASK CUSTOMER FOR DRIVING CONDITIONS

1. Is there any trace of contamination or foreign material on ICC sensor?
2. Is there any possibility that vehicle was driven in snow or ICC sensor was frosted?
3. Is there any possibility that ICC sensor was fogged temporarily? (Front window glass may have also been fogged.)

Was the ICC sensor obstructed by normal conditions?

YES >> Explain system operation and parameters to customer. System may be operating normally.

NO >> • Replace ICC sensor and adjust laser beam aiming. Refer to [CCS-72, "ICC Sensor"](#).

- Erase DTC and perform ICC system running test. Refer to [CCS-8, "ACTION TEST : ICC System Running Test"](#).

DTC 103 LASER SENSOR FAIL

< COMPONENT DIAGNOSIS >

DTC 103 LASER SENSOR FAIL

DTC 103 LASER SENSOR FAIL

INFOID:000000005146000

1. DIAGNOSTIC CHECK

Perform self-diagnosis.

Are "DTC 11 CONTROL UNIT" or DTC 20 CAN COMM CIRCUIT" indicated in self diagnosis?

- YES >> GO TO applicable item inspection. Refer to [CCS-22. "DTC 11 CONTROL UNIT"](#), and [CCS-24. "DTC 20 CAN COMM CIRCUIT"](#).
- NO >> • Replace ICC sensor and adjust laser beam aiming. Refer to [CCS-72. "ICC Sensor"](#).
• Erase DTC and perform ICC system running test. Refer to [CCS-8. "ACTION TEST : ICC System Running Test"](#).

A
B
C
D
E
F
G
H
I
J
K
L
M
N
P

CCS

DTC 104 LASER AIMING INCOMP

< COMPONENT DIAGNOSIS >

DTC 104 LASER AIMING INCOMP

DTC 104 LASER AIMING INCOMP

INFOID:000000005146001

1. DIAGNOSTIC CHECK

1. Adjust laser beam aiming. Refer to [CCS-5, "LASER BEAM AIMING ADJUSTMENT : Outline of Laser Beam Aiming Adjustment Procedure"](#). Erase DTC and perform ICC system running test. Refer to [CCS-8, "ACTION TEST : ICC System Running Test"](#).
2. Perform self-diagnosis of ICC system.

Is "DTC 104 LASER AIMING INCOMP" indicated?

- YES >> • Replace ICC sensor and adjust laser beam aiming. Refer to [CCS-72, "ICC Sensor"](#).
• Erase DTC and perform ICC system running test. Refer to [CCS-8, "ACTION TEST : ICC System Running Test"](#).
- NO >> Inspection end.

DTC 107 LASER COMM FAIL

< COMPONENT DIAGNOSIS >

DTC 107 LASER COMM FAIL

DTC 107 LASER COMM FAIL

INFOID:000000005146002

1. DIAGNOSTIC CHECK

Perform self-diagnosis?

Is "DTC 11 CONTROL UNIT" or "DTC 20 CAN COMM CIRCUIT" indicated?

- YES >> GO TO applicable item inspection. Refer to [CCS-22. "DTC 11 CONTROL UNIT"](#), or [CCS-24. "DTC 20 CAN COMM CIRCUIT"](#).
- NO >> • Replace ICC sensor and adjust laser beam aiming. Refer to [CCS-72. "ICC Sensor"](#).
• Erase DTC and perform ICC system running test. Refer to [CCS-8. "ACTION TEST : ICC System Running Test"](#).

A
B
C
D
E
F
G
H
I
J
K
L
M
N
P

CCS

DTC109 LASER HIGH TEMP

< COMPONENT DIAGNOSIS >

DTC109 LASER HIGH TEMP

DTC 109 LASER HIGH TEMP

INFOID:000000005146003

1.CHECK SYMPTOM

Inspect engine cooling system.

Did the engine overheat?

- YES >>
- Repair cooling system.
 - Erase DTC and perform ICC system running test. Refer to [CCS-8, "ACTION TEST : ICC System Running Test"](#). Then perform self-diagnosis of ICC system again.
- NO >>
- Replace ICC sensor and adjust laser beam aiming. Refer to [CCS-72, "ICC Sensor"](#).
 - Erase DTC, then perform ICC system running test. Refer to [CCS-8, "ACTION TEST : ICC System Running Test"](#). Then perform self-diagnosis of ICC system again.

ICC UNIT

< ECU DIAGNOSIS >

ECU DIAGNOSIS

ICC UNIT

Terminal and Reference Value for ICC Unit

INFOID:000000005146004

Terminal	Wire color	Item	Condition		Voltage (V) (Approx.)	
			Ignition switch	Operation		
1	W/L	Battery power supply	OFF	—	Battery voltage	
2	W/L					
5	P	CAN-L	—	—	—	
7	B/R	N-P RANGE	ON	A/T selector lever in "P" or "N"	Battery voltage	
10	V/R	Brake booster signal	ON	—	Approx. 12V Approx. 5V  SKIA1243E	
14	L	CAN-H	—	—	—	
19	B	Ground	—	—	—	
20	B					
29	BR/W	ICC brake switch (normally closed)	ON	Selector lever: Not in "N" or "P" position	Depress the brake pedal	0
					Release the brake pedal	Battery voltage
30	L	TX	—	—	—	
33	R/B	Ignition switch power supply	ON	—	Battery voltage	
38	R/G	Stop lamp switch (normally open)	OFF	Depress the brake pedal		
				Release the brake pedal	0	
39	V/W	RX	—	—	—	
40	G	Parking brake signal	ON	Parking brake is ON	0	
				Parking brake is OFF	Battery voltage	
42	R/B	Ignition switch power supply	—	—	Battery voltage	
46	B	Ground	—	—	—	
47	BR	Stop lamp drive output signal	ON	Brake operating with ICC system	Battery voltage	
				Brake not operating with ICC system	0	

A
B
C
D
E
F
G
H
I
J
K
L
M
N
P

CCS

ICC UNIT

< ECU DIAGNOSIS >

Wiring Diagram

INFOID:000000005146005

INTELLIGENT CRUISE CONTROL SYSTEM

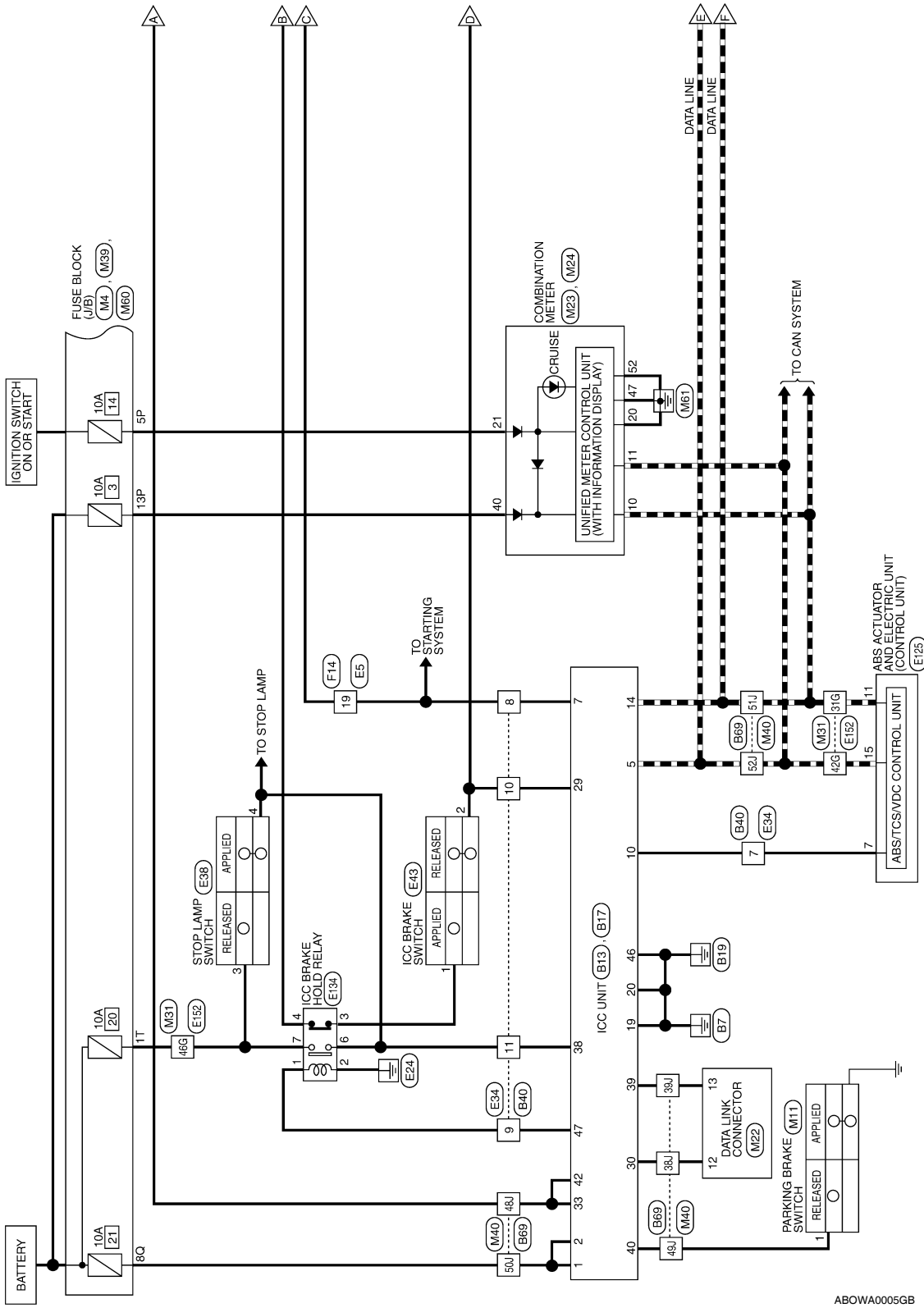

ABOWA0005GB

ICC UNIT

< ECU DIAGNOSIS >

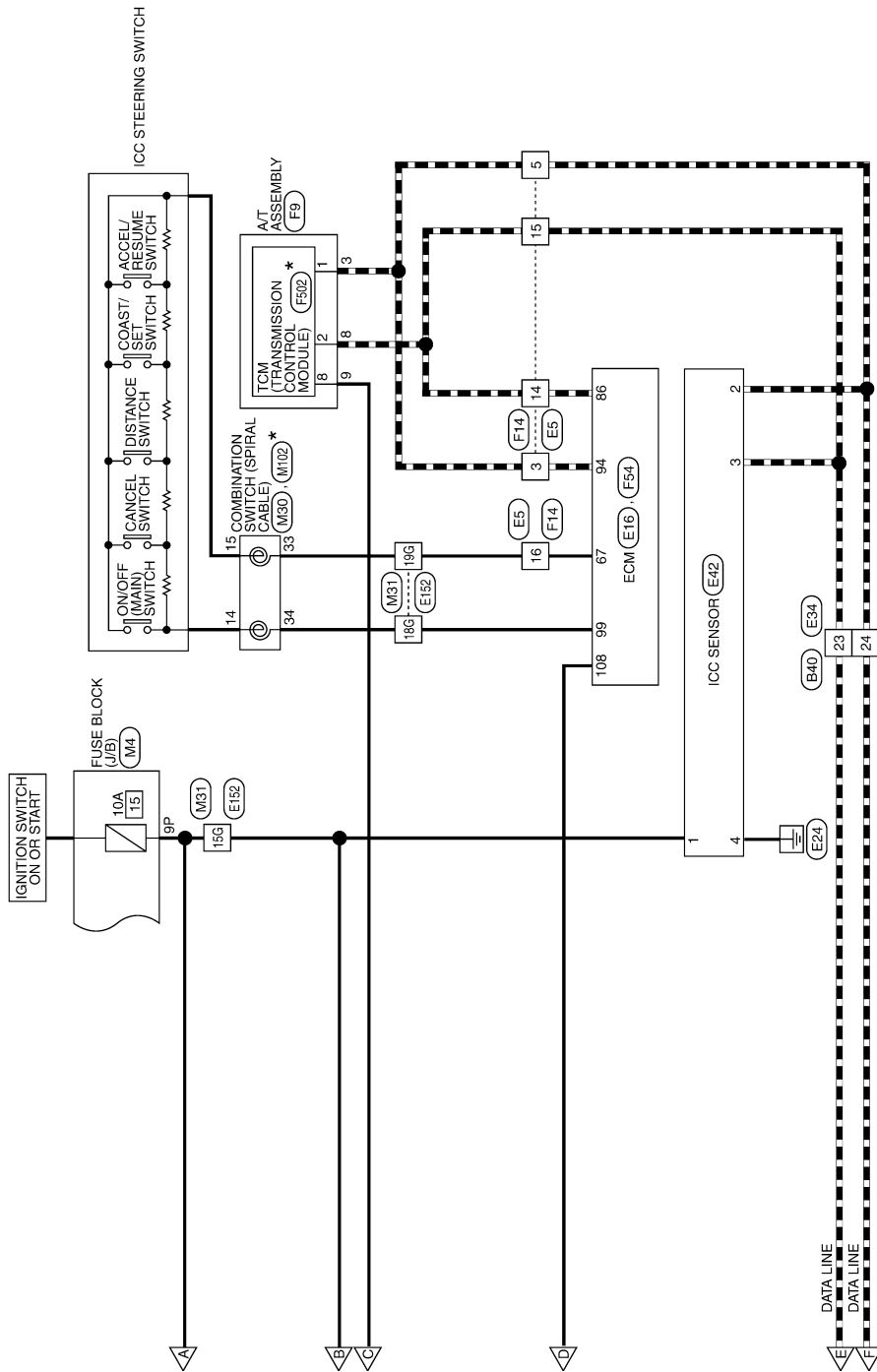

*: THIS CONNECTOR IS NOT SHOWN IN "HARNES LAYOUT" OF PG SECTION.

ABOWA0004GB

A
B
C
D
E
F
G
H
I
J
K
L
M
N
P



INTELLIGENT CRUISE CONTROL SYSTEM CONNECTORS

Connector No.	M4
Connector Name	FUSE BLOCK (J/B)
Connector Color	WHITE



Terminal No.	Color of Wire	Signal Name
5P	O/L	-
9P	R/B	-
13P	P	-

Connector No.	M11
Connector Name	PARKING BRAKE SWITCH
Connector Color	BLACK



Terminal No.	Color of Wire	Signal Name
1	G	-

Connector No.	M22
Connector Name	DATA LINK CONNECTOR
Connector Color	WHITE

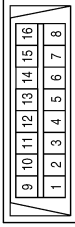

Terminal No.	Color of Wire	Signal Name
12	L	-
13	V/W	-

Connector No.	M23
Connector Name	COMBINATION METER
Connector Color	WHITE

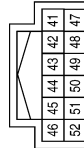

Terminal No.	Color of Wire	Signal Name
47	B	POWER GND
52	B	POWER GND

Connector No.	M24
Connector Name	COMBINATION METER
Connector Color	WHITE



Terminal No.	Color of Wire	Signal Name
10	L	CAN-H
11	P	CAN-L
20	B	GROUND
21	O/L	RUN/START
40	P	BATTERY

Connector No.	M30
Connector Name	COMBINATION SWITCH
Connector Color	GRAY

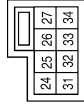

Terminal No.	Color of Wire	Signal Name
33	B	-
34	G/Y	-

ICC UNIT

< ECU DIAGNOSIS >

Connector No.	M39
Connector Name	FUSE BLOCK (J/B)
Connector Color	WHITE

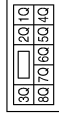

Terminal No.	Color of Wire	Signal Name
8Q	W/L	-

Terminal No.	Color of Wire	Signal Name
15G	R/B	-
18G	G/Y	-
19G	B	-
31G	L	-
42G	P	-
46G	R/Y	-

Connector No.	M31
Connector Name	WIRE TO WIRE
Connector Color	WHITE

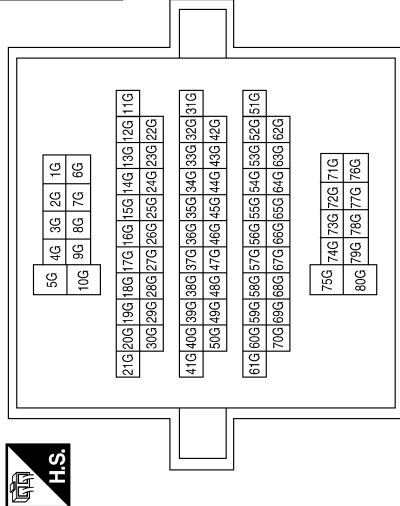

Connector No.	M60
Connector Name	FUSE BLOCK (J/B)
Connector Color	WHITE

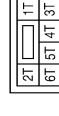

Terminal No.	Color of Wire	Signal Name
1T	R/Y	-

Terminal No.	Color of Wire	Signal Name
38J	L	-
39J	V/W	-
48J	R/B	-
49J	G	-
50J	W/L	-
51J	L	-
52J	P	-

Connector No.	M40
Connector Name	WIRE TO WIRE
Connector Color	WHITE

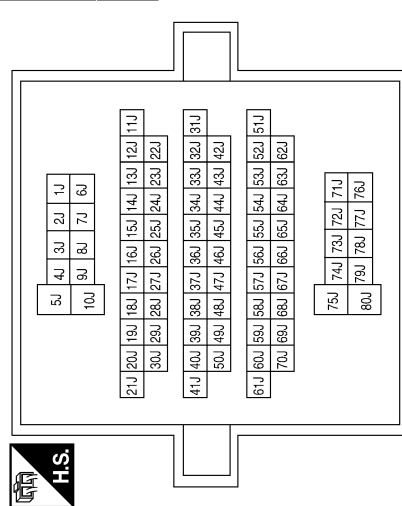

ABOIA0012GB

A
B
C
D
E
F
G
H
I
J
K
L
M
N
P



ICC UNIT

< ECU DIAGNOSIS >

Connector No.	E16
Connector Name	ECM
Connector Color	BLACK

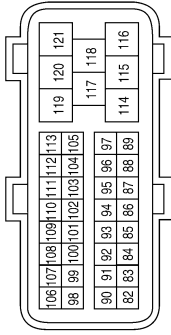

Terminal No.	Color of Wire	Signal Name
86	P	CAN-L
94	L	CAN-H
99	G/Y	ASCDSW
108	BR/W	BNC SW

Connector No.	E42
Connector Name	ICC SENSOR
Connector Color	BLACK

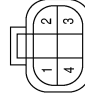

Terminal No.	Color of Wire	Signal Name
1	R/B	IGN PWR
2	L	CAN-H
3	P	CAN-L
4	B	-

Connector No.	E5
Connector Name	WIRE TO WIRE
Connector Color	WHITE

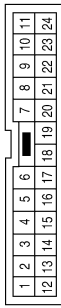

Terminal No.	Color of Wire	Signal Name
3	L	-
5	L	-
14	P	-
15	P	-
16	B	-
19	B/R	-

Connector No.	E38
Connector Name	STOP LAMP SWITCH
Connector Color	WHITE



Terminal No.	Color of Wire	Signal Name
3	R/Y	-
4	R/G	-

Connector No.	M102
Connector Name	COMBINATION SWITCH
Connector Color	GRAY



Terminal No.	Color of Wire	Signal Name
14	Y	-
15	B	-

Connector No.	E34
Connector Name	WIRE TO WIRE
Connector Color	WHITE

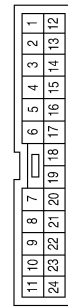

Terminal No.	Color of Wire	Signal Name
7	V/R	-
8	B/R	-
9	BR	-
10	BR/W	-
11	R/G	-
23	P	-
24	L	-

A01A0008GB

ICC UNIT

< ECU DIAGNOSIS >

Connector No.	E43
Connector Name	ICC BRAKE SWITCH
Connector Color	BROWN



Terminal No.	Color of Wire	Signal Name
1	L	-
2	BR/W	-

Connector No.	E125
Connector Name	ABS ACTUATOR AND ELECTRIC UNIT (CONTROL UNIT)
Connector Color	BLACK



Terminal No.	Color of Wire	Signal Name													
1	2	3	4	5	6	7	8	9	10	11	12	13	14	15	16
17	18	19	20	21	22	23	24	25	26	27	28	29	30	31	32
33	34	35	36	37	38	39	40	41	42	43	44	45	46	47	

Terminal No.	Color of Wire	Signal Name
7	V/R	BST INH
11	L	CAN-H
15	P	CAN-L

Connector No.	E134
Connector Name	ICC BRAKE HOLD RELAY
Connector Color	GRAY



Terminal No.	Color of Wire	Signal Name
1	BR	-
2	B	-
3	L	-
4	R/B	-
6	R/G	-
7	R/Y	-

Connector No.	E152
Connector Name	WIRE TO WIRE
Connector Color	WHITE

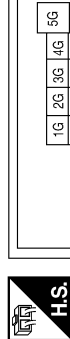

11G	12G	13G	14G	15G	16G	17G	18G	19G	20G	21G
22G	23G	24G	25G	26G	27G	28G	29G	30G		
31G	32G	33G	34G	35G	36G	37G	38G	39G	40G	41G
42G	43G	44G	45G	46G	47G	48G	49G	50G		
51G	52G	53G	54G	55G	56G	57G	58G	59G	60G	61G
62G	63G	64G	65G	66G	67G	68G	69G	70G		
71G	72G	73G	74G	75G						

Terminal No.	Color of Wire	Signal Name
15G	R/B	-
18G	G/Y	-
19G	B	-
31G	L	-
42G	P	-
46G	R/Y	-

Connector No.	F9
Connector Name	A/T ASSEMBLY
Connector Color	GREEN



Terminal No.	Color of Wire	Signal Name
3	L	-
8	P	-
9	B/R	-

ABOIA0009GB

A
B
C
D
E
F
G
H
I
J
K
L
M
N
P



ICC UNIT

< ECU DIAGNOSIS >

Connector No.	F502
Connector Name	TCM (TRANSMISSION CONTROL MODULE)
Connector Color	GRAY



Terminal No.	Color of Wire	Signal Name
1	BR	CAN-H
2	L/Y	CAN-L
8	G	START-RLY

Connector No.	F54
Connector Name	ECM
Connector Color	BLACK

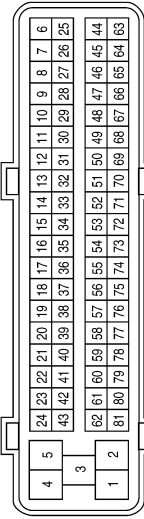

Terminal No.	Color of Wire	Signal Name
67	B	GND-A

Connector No.	F14
Connector Name	WIRE TO WIRE
Connector Color	WHITE

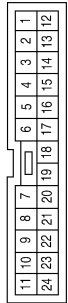

Terminal No.	Color of Wire	Signal Name
3	L	-
5	L	-
14	P	-
15	P	-
16	B	-
19	B/R	-

Connector No.	BT3
Connector Name	ICC UNIT
Connector Color	WHITE

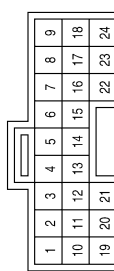

Terminal No.	Color of Wire	Signal Name
1	W/L	B
2	W/L	B
3	-	-
4	-	-
5	P	CAN-L
6	-	-
7	B/R	N-P RANGE
8	-	-
9	-	-
10	V/R	-

Terminal No.	Color of Wire	Signal Name
11	-	-
12	-	-
13	-	-
14	L	CAN-H
15	-	-
16	-	-
17	-	-
18	-	-
19	B	GND
20	B	GND
21	-	-
22	-	-
23	-	-
24	-	-

A01A0010GB

ICC UNIT

< ECU DIAGNOSIS >

Connector No.	B69
Connector Name	WIRE TO WIRE
Connector Color	WHITE

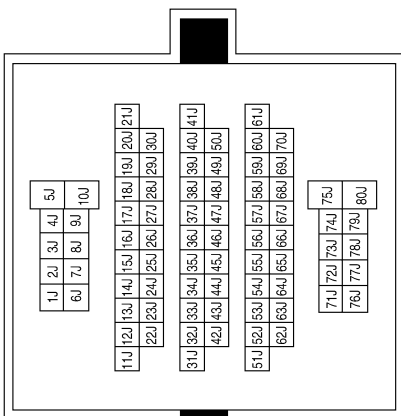

Terminal No.	Color of Wire	Signal Name
38J	L	-
39J	V/W	-
48J	R/B	-
49J	G	-
50J	W/L	-
51J	L	-
52J	P	-

Connector No.	B40
Connector Name	WIRE TO WIRE
Connector Color	WHITE

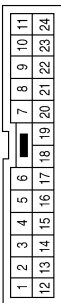

Terminal No.	Color of Wire	Signal Name
7	V/R	-
8	B/R	-
9	BR	-
10	BR/W	-
11	R/G	-
23	P	-
24	L	-

Connector No.	B17
Connector Name	ICC UNIT
Connector Color	GRAY

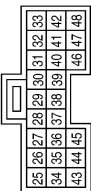

Terminal No.	Color of Wire	Signal Name
25	-	-
26	-	-
27	-	-
28	-	-
29	BR/W	-
30	L	TX
31	-	-
32	-	-
33	R/B	IGN
34	-	-
35	-	-
36	-	-
37	-	-
38	R/G	BVO SW
39	V/W	RX
40	G	PKB
41	-	-
42	R/B	IGN
43	-	-
44	-	-
45	-	-
46	B	GND
47	BR	-
48	-	-

AB0IA0007GB

INFOID:000000005146006

Fail Safe

When a malfunction occurs in ICC system, a chime sounds a beep, the system is released and ICC system warning lamp in combination meter illuminates. System setting is not accepted when malfunction is detected.

A
B
C
D
E
F
G
H
I
J
K
L
M
N
P



ICC UNIT

< ECU DIAGNOSIS >

Diagnostic Trouble Code (DTC) Chart

INFOID:000000005146007

×:Applicable

DTC No.	CONSULT-III screen terms	ICC system warning lamp	Fail-safe			Malfunctions detected where...	Reference page
			Vehicle-to-vehicle distance control mode	Conventional (fixed speed) cruise control mode	Brake assist (with preview function)		
11	CONTROL UNIT	×	×	×	×	• ICC unit internal malfunction	CCS-22
12	VDC CONTROL UNIT	×	×	×	×	• VDC malfunction • Brake booster signal harness is open or shorted	CCS-23
20	CAN COMM CIRCUIT	×	×	×	×	• ICC unit detected CAN communication malfunction	CCS-24
31	POWER SUPPLY CIR1	×	×	×	×	• ICC unit power supply voltage is excessively low (less than 8V)	CCS-25
34	POWER SUPPLY CIR2	×	×	×	×	• ICC unit power supply voltage is excessively high.	CCS-25
41	VHCL SPEED SE CIRC	×	×	×	×	• Wheel sensor malfunction • ABS actuator and electric unit (control unit) malfunction • A/T vehicle speed sensor malfunction • TCM malfunction	CCS-26
43	VDC/TCS/ABS CIRC	×	×	×	×	• VDC/TCS/ABS system malfunction	CCS-27
45	BRAKE SW/ STOP L SW	×	×	×	×	• ICC brake switch or stop lamp switch harness is open or shorted • ICC brake switch or stop lamp switch is stuck to OFF • ICC brake switch or stop lamp switch is stuck to ON	CCS-28
46	OPERATION SW CIRC	×	×	×		• ICC steering switch harness or spiral cable is open or shorted • ICC steering switch malfunction	CCS-30
74	LASER BEAM OFF CNTR	×	×		×	• Laser beam of ICC sensor is off the aiming point	CCS-32
90	STOP LAMP RLY FIX	×	×		×	• Normally open terminal of stop lamp relay is stuck	CCS-33
92	ECM CIRCUIT	×	×	×	×	• ECM malfunction • Accelerator pedal position sensor malfunction • ICC unit malfunction	CCS-38
96	NP RANGE	×	×	×		• Transmission range switch harness is open or shorted • Transmission range switch malfunction • TCM malfunction	CCS-39
97	AT CIRCUIT	×	×	×		• TCM malfunction	CCS-40
98	GEAR POSITION	×	×	×		• TCM malfunction • A/T input speed sensor malfunction • A/T vehicle speed sensor malfunction	CCS-41

ICC UNIT

< ECU DIAGNOSIS >

DTC No.	CONSULT-III screen terms	ICC system warning lamp	Fail-safe			Malfunctions detected where...	Reference page
			Vehicle-to-vehicle distance control mode	Conventional (fixed speed) cruise control mode	Brake assist (with preview function)		
102	LASER STAIN	×	×		×	• ICC sensor body window has contamination	CCS-42
103	LASER SENSOR FAIL	×	×		×	• ICC sensor internal malfunction	CCS-43
104	LASER AIMING INCMP	×	×		×	• Laser beam aiming of ICC sensor is not adjusted	CCS-44
107	LASER COMM FAIL	×	×		×	• CAN data received by ICC sensor is strange (from ICC unit, combination meter or ECM)	CCS-45
109	LASER HIGH TEMP	×	×		×	• Temperature around ICC sensor is excessively high	CCS-46

NOTE: DTC 55 will display when no malfunction is detected.

A
B
C
D
E
F
G
H
I
J
K
L
M
N
P

CCS

INTELLIGENT CRUISE CONTROL SYSTEM SYMPTOMS

< SYMPTOM DIAGNOSIS >

SYMPTOM DIAGNOSIS

INTELLIGENT CRUISE CONTROL SYSTEM SYMPTOMS

Symptom Chart

INFOID:000000005146008

	Symptoms	Reference page
Operation	ON/OFF switch does not switch ON.	CCS-59
	ON/OFF switch does not switch OFF.	CCS-59
	Cruise does not function for setting (powering functions).	CCS-60
	CANCEL switch does not function.	CCS-61
	RESUME does not function.	CCS-61
	The set speed does not increase.	CCS-61
	The set distance to the vehicle ahead cannot be changed.	CCS-61
	The ICC is not cancelled when the gear is in "N".	CCS-62
Display/Chime	The ICC system display does not appear.	Check combination meter. Refer to MWI-22. "Diagnosis Description"
	Chime does not function.	CCS-63
Control	Driving force is hunting.	CCS-64
Function to detect the vehicle ahead	The system frequently cannot detect the vehicle ahead.	CCS-65
	The distance to detect the vehicle ahead is short.	CCS-65
	The system misidentifies a vehicle even though there is no vehicle ahead.	<ul style="list-style-type: none"> Refer to CCS-5. "LASER BEAM AIMING ADJUSTMENT : Outline of Laser Beam Aiming Adjustment Procedure" Refer to CCS-8. "ACTION TEST : ICC System Running Test"
	The system misidentifies a vehicle in the next lane.	<ul style="list-style-type: none"> Refer to CCS-5. "LASER BEAM AIMING ADJUSTMENT : Outline of Laser Beam Aiming Adjustment Procedure" Refer to CCS-8. "ACTION TEST : ICC System Running Test"
	The system does not detect a vehicle at all.	CCS-66

MAIN SWITCH DOES NOT TURN ON, MAIN SWITCH DOES NOT TURN OFF

< SYMPTOM DIAGNOSIS >

MAIN SWITCH DOES NOT TURN ON, MAIN SWITCH DOES NOT TURN OFF

Diagnosis Procedure

INFOID:000000005146009

NOTE:

- *1: The ICC system display in the combination meter does not illuminate.
- *2: The ICC system display in the combination meter remains powered.

1. CHECK ON/OFF SWITCH

With "DATA MONITOR", check that ON/OFF switch operates normally.

Does ON/OFF switch operate normally?

YES >> GO TO 2

NO >> GO TO 3

2. CHECK ICC UNIT CONNECTOR

1. Turn ignition switch OFF.
2. Disconnect ICC unit harness connectors.
3. Check connector housing for disconnected, loose, bent, and collapsed terminals.

Does the ICC unit pass inspection?

YES >> GO TO 3

NO >> • Poor connector connection.

- Repair ICC unit connector. Erase DTC and perform ICC system running test. Refer to [CCS-8, "ACTION TEST : ICC System Running Test"](#).

3. DIAGNOSIS CHECK

Perform self-diagnosis.

Is "CAN COMM CIRCUIT" indicated?

YES >> Refer to [CCS-24, "DTC 20 CAN COMM CIRCUIT"](#).

NO >> Refer to [CCS-30, "DTC 46 OPERATION SW CIRC"](#).

A
B
C
D
E
F
G
H
I
J
K
L
M
N
P

CCS

ICC SYSTEM CANNOT BE SET (MAIN SWITCH TURNS ON/OFF)

< SYMPTOM DIAGNOSIS >

ICC SYSTEM CANNOT BE SET (MAIN SWITCH TURNS ON/OFF)

Diagnosis Procedure

INFOID:000000005146010

The ICC cannot be set in the following cases.

- When the vehicle speed is not in range of approx. 40 km/h (25 MPH) to 144 km/h (89 MPH).
- When the selector lever is in "N".
- While the brake is in operation.
- When the windshield wipers are operating.

1. CHECK CAUSE OF AUTOMATIC CANCELLATION

1. With "CAUSE OF AUTO-CANCEL" in "WORK SUPPORT", check if any cause of cancellation exists.

Is there a cause of cancellation stored?

YES >> • Cancel with appropriate cause.

- For causes A, B, or C, go to specified diagnosis.

A: "OPE SW VOLT CIRC" : Refer to [CCS-30. "DTC 46 OPERATION SW CIRC"](#).

B: "VHCL SPD UNMATCH" : Refer to [CCS-26. "DTC 41 VHCL SPEED SE CIRC"](#).

C: "IGN LOW VOLT" : Refer to [CCS-25. "DTC 31 POWER SUPPLY CIR1, DTC 34 POWER SUPPLY CIR2"](#).

NO >> GO TO 2

2. PERFORM SELF-DIAGNOSIS

1. Perform -self-diagnosis to check for malfunctioning items.

Does the ICC have any DTC's stored?

YES >> Repair or replace as necessary, erase DTC. Perform ICC system running test. Refer to [CCS-8. "ACTION TEST : ICC System Running Test"](#).

NO >> GO TO 3

3. CHECK SWITCHES AND VEHICLE SPEED SIGNAL

1. With "DATA MONITOR", check that the following switches and vehicle speed signal operate normally.

A: VHCL SPEED SE B: NP RANGE SW

C: BRAKE SW D: SET/COAST SW

Do the monitor items display properly?

YES >> Replace ICC unit and erase DTC. Refer to [CCS-71. "ICC Unit"](#). Perform ICC system running test. Refer to [CCS-8. "ACTION TEST : ICC System Running Test"](#).

NO >> • A: Refer to [CCS-26. "DTC 41 VHCL SPEED SE CIRC"](#).

- B: Refer to [CCS-62. "Diagnosis Procedure"](#).

- C: Refer to [CCS-28. "DTC 45 BRAKE SW/STOP L SW"](#).

- D: Refer to [CCS-30. "DTC 46 OPERATION SW CIRC"](#).

ICC STEERING SWITCH (OTHER THAN MAIN SWITCH) DOES NOT FUNCTION

< SYMPTOM DIAGNOSIS >

ICC STEERING SWITCH (OTHER THAN MAIN SWITCH) DOES NOT FUNCTION

Diagnosis Procedure

INFOID:000000005146011

RESUME will not function in the following cases:

- When ON/OFF switch is pressed once after the ICC system was ON.
- When the vehicle speed is less than 32 km/h (20 MPH).

1.CHECK SWITCH

1. With "DATA MONITOR", check that the following switches operate normally.
"RESUME/ACC SW", "CANCEL SW", "DISTANCE ADJ".

Do the monitor items display properly?

YES >> Replace ICC unit and erase DTC. Refer to [CCS-71, "ICC Unit"](#). Perform ICC system running test.
Refer to [CCS-8, "ACTION TEST : ICC System Running Test"](#).

NO >> GO TO 2

2.CHECK DIAGNOSIS

Perform self-diagnosis with CONSULT-III.

Is "CAN COMM CIRCUIT" indicated?

YES >> Refer to [CCS-24, "DTC 20 CAN COMM CIRCUIT"](#).

NO >> Refer to [CCS-30, "DTC 46 OPERATION SW CIRC"](#).

A
B
C
D
E
F
G
H
I
J
K
L
M
N
P

CCS

ICC SYSTEM DOES NOT CANCEL WHEN A/T SELECTOR LEVER SETS ON "N"

< SYMPTOM DIAGNOSIS >

ICC SYSTEM DOES NOT CANCEL WHEN A/T SELECTOR LEVER SETS ON "N"

Diagnosis Procedure

INFOID:000000005146012

1. CHECK D RANGE SWITCH

1. With "DATA MONITOR", check that "NP RANGE SW" operates normally.

Does the monitor item display normally?

YES >> Replace ICC unit and erase DTC. Refer to [CCS-71, "ICC Unit"](#). Perform ICC system running test. Refer to [CCS-8, "ACTION TEST : ICC System Running Test"](#).

NO >> GO TO 2

2. CHECK CAN COMMUNICATION

1. With self-diagnosis, check "CAN COMM CIRCUIT".

Does "CAN COMM CIRCUIT" display with self-diagnosis?

YES >> Refer to [CCS-24, "DTC 20 CAN COMM CIRCUIT"](#).

NO >> GO TO 3

3. CHECK NP RANGE SWITCH

1. With "DATA MONITOR", check that "N" position switch operates normally.

Does the monitor item display normally?

YES >> Replace ICC unit. Refer to [CCS-71, "ICC Unit"](#). Perform ICC system running test. Refer to [CCS-8, "ACTION TEST : ICC System Running Test"](#).

NO >> Repair or replace as necessary. Perform ICC system running test. Refer to [CCS-8, "ACTION TEST : ICC System Running Test"](#).

CHIME DOES NOT SOUND

< SYMPTOM DIAGNOSIS >

CHIME DOES NOT SOUND

Diagnosis Procedure

INFOID:000000005146013

The chime may not sound occasionally in the following cases even if the distance from the vehicle ahead is short:

- When the speed difference from that of the vehicle ahead is small (both vehicles driving at similar speed).
- When the vehicle ahead drives at faster speed (the actual distance is increasing).
- When depressing the accelerator.
- Chime does not sound when the vehicle is not driving.
- Chime does not sound when the system does not detect any vehicle ahead. Diagnose the conditions under which the system is detecting the vehicle ahead and when the system is malfunctioning. If there is any malfunction in detecting the vehicle ahead. Refer to [CCS-65, "Diagnosis Procedure"](#).

1. CHECK ICC WARNING CHIME

Check warning chime operation.

Did the ICC warning chime fail to operate?

YES >> Determine preceding vehicle detection status when malfunction occurred. If chime should have sounded replace ICC unit. Refer to [CCS-71, "ICC Unit"](#). Perform ICC system running test. Refer to [CCS-8, "ACTION TEST : ICC System Running Test"](#).

NO >> GO TO 2

2. CAN COMMUNICATION INSPECTION

1. With -self-diagnosis, check "CAN COMM CIRCUIT".

Does "CAN COMM CIRCUIT" display with self-diagnosis?

YES >> Refer to [CCS-24, "DTC 20 CAN COMM CIRCUIT"](#).

NO >> Replace combination meter. Refer to [MWI-100, "Removal and Installation"](#). Erase DTC and perform ICC system running test. Refer to [CCS-8, "ACTION TEST : ICC System Running Test"](#).

A
B
C
D
E
F
G
H
I
J
K
L
M
N
P

CCS

DRIVING FORCE IS HUNTING

< SYMPTOM DIAGNOSIS >

DRIVING FORCE IS HUNTING

Diagnosis Procedure

INFOID:000000005146014

1. CHECK ECM

1. Perform self-diagnosis of ECM.

Does the ECM pass the self-diagnosis test?

YES >> Refer to [CCS-65, "Diagnosis Procedure"](#).

NO >> Repair as necessary. Erase DTC and perform ICC system running test. Refer to [CCS-8, "ACTION TEST : ICC System Running Test"](#).

ICC SYSTEM FREQUENTLY CANNOT DETECT THE VEHICLE AHEAD/ DETECTION ZONE IS SHORT

< SYMPTOM DIAGNOSIS >

ICC SYSTEM FREQUENTLY CANNOT DETECT THE VEHICLE AHEAD/ DETECTION ZONE IS SHORT

Diagnosis Procedure

INFOID:000000005146015

The detection function may become disrupted in the following cases:

- When the reflector of the vehicle ahead is small or not clean enough to reflect the laser.
- When driving a road with extremely sharp corners.
- When the laser cannot detect the reflector of the vehicle ahead as the vehicle ahead is passing a hill or passing the peak.

1.VISUAL CHECK

1. Check ICC sensor body window for contamination and foreign materials.

Is the ICC sensor window clean and free of obstruction?

YES >> GO TO 2

NO >> If any contamination or foreign materials are found, remove them. Then perform ICC system running test. Refer to [CCS-8, "ACTION TEST : ICC System Running Test"](#).

2.CHECK FUNCTION

1. After performing laser beam aiming adjustment, perform ICC system running test. Refer to [CCS-8, "ACTION TEST : ICC System Running Test"](#). Check that preceding vehicle detection performance has been improved.

Is the ICC system operating normally?

YES >> INSPECTION END.

NO >> • Replace ICC sensor and perform laser beam aiming adjustment. Refer to [CCS-72, "ICC Sensor"](#).
• Perform ICC system running test. Refer to [CCS-8, "ACTION TEST : ICC System Running Test"](#).

A
B
C
D
E
F
G
H
I
J
K
L
M
N
P



THE SYSTEM DOES NOT DETECT THE VEHICLE AHEAD AT ALL

< SYMPTOM DIAGNOSIS >

THE SYSTEM DOES NOT DETECT THE VEHICLE AHEAD AT ALL

Diagnosis Procedure

INFOID:000000005146016

1. VISUAL CHECK

With ignition switch turned ON (engine not started), check that all indicator lamps in ICC system display are continuously lit. (Check for a missing segment in preceding vehicle detection display.)

Does the display operate normally?

YES >> GO TO 2

NO >> Check combination meter. Refer to [MWI-22, "Diagnosis Description"](#).

2. VISUAL CHECK

Check ICC sensor window for contamination and foreign materials.

Is the ICC sensor window clean and free of obstruction?

YES >> If any contamination or foreign materials are found, remove them. Perform ICC system running test. Refer to [CCS-8, "ACTION TEST : ICC System Running Test"](#).

NO >> GO TO 3

3. VISUAL CHECK

Check ICC sensor window for cracks and scratches.

Is the ICC sensor window intact?

YES >> GO TO 4

NO >> • Replace ICC sensor and perform laser beam aiming adjustment. Refer to [CCS-72, "ICC Sensor"](#).

• Perform ICC system running test. Refer to [CCS-8, "ACTION TEST : ICC System Running Test"](#).

4. ADJUST ICC SENSOR

• After performing laser beam aiming adjustment, perform ICC system running test. Refer to [CCS-8, "ACTION TEST : ICC System Running Test"](#). Check that preceding vehicle detection performance has been improved.

Is the ICC system operating normally?

YES >> INSPECTION END.

NO >> • Replace ICC sensor and perform laser beam aiming adjustment. Refer to [CCS-72, "ICC Sensor"](#).

• Perform ICC system running test. Refer to [CCS-8, "ACTION TEST : ICC System Running Test"](#).

NORMAL OPERATING CONDITION

< SYMPTOM DIAGNOSIS >

NORMAL OPERATING CONDITION

Description

INFOID:000000005146017

PRECAUTIONS FOR VEHICLE-TO-VEHICLE DISTANCE CONTROL MODE

- Intelligent Cruise Control is functionally limited. This never support careless driving and low visibility (rain, fog, etc.). Drive the vehicle safely. Keep a safe distance between vehicles by decreasing the vehicle speed according to the driving condition etc.
- Intelligent Cruise Control never stop the vehicle automatically. Intelligent Cruise Control is automatically released, and the buzzer sounds if any vehicle ahead is not detected when the vehicle speed is approximately 35 km (21.5 MPH) or less.
- Use this system when the vehicle speed does not extremely change. This system may not properly function when any vehicle cuts in, or when the vehicle ahead suddenly applies the brake. Then, the warning (buzzer and indication) activates.
- Never use Intelligent Cruise Control in the following conditions.
 - A well-trafficed road, and a tight turn.
It may cause any accident because the driving does not fit to the road condition.
 - A slippery road (e.g., freezing, or snowy road)
The vehicle may lose the control by wheelspin.
 - The vehicle drives in bad whether (rain, fog, snow etc.).
The distance from the vehicle ahead is not detected precisely if the whether condition is bad. Intelligent Cruise Control is released automatically if the wiper activates in low or high speed.
 - The vehicle receives bright light (sunshine etc.).
The distance from the vehicle ahead is not detected precisely if bright light enters in the vehicle.
 - Raindrop or snow is on the sensor.
The distance from the vehicle ahead is not detected precisely if raindrop or snow attaches on the sensor.
 - A steep downhill
The setting vehicle speed may exceed if Intelligent Cruise Control does not detect the vehicle ahead. The brake may heat up in the vehicle-to-vehicle distance control mode.
 - A repeated uphill and downhill
Intelligent Cruise Control may not detect the vehicle ahead precisely. An accident may occur by tailgating.
- Maintaining proper vehicle distance is difficult due to frequent acceleration/deceleration.
It may cause any accident because the driving does not fit to the road condition if keeping a proper vehicle-to-vehicle distance is difficult.
- When entering in the highway interchange (swerving off the main line),
Unexpected accident may cause if the vehicle ahead drives slower than the preset vehicle speed. The vehicle-to-vehicle distance control mode accelerates automatically because the vehicle ahead is not detected on the lane if the own vehicle or the vehicle ahead changes the lane.
- Intelligent Cruise Control does not activate to the parking vehicles, and vehicles driving extremely slower than the own vehicle. Never hit the vehicle stopping at a tollgate, or the tail end of traffic jam.
- Intelligent Cruise Control does not activate to the vehicle edging way, and non-vehicle objects (passengers etc.).
- This function detects the reflector of the vehicle ahead. Intelligent Cruise Control may not detect the vehicle ahead, and keep a proper vehicle-to-vehicle distance in the following conditions. Drive the vehicle according to the driving condition.
 - The vehicle ahead installs the reflector higher (trailer etc.).
 - The rear of the vehicle ahead is extremely dirt.
 - The vehicle ahead or vehicle on other lanes splashes water or snow on the road.
 - The vehicle ahead provides dark exhaust gas. Smoke blocks the visibility.
 - The vehicle ahead attaches film on the reflector. The vehicle ahead does not install the reflector. The reflector is broken.
 - Extremely heavy load is on the rear seat or in the cargo area.
 - The vehicle drives on a repeated uphill and downhill

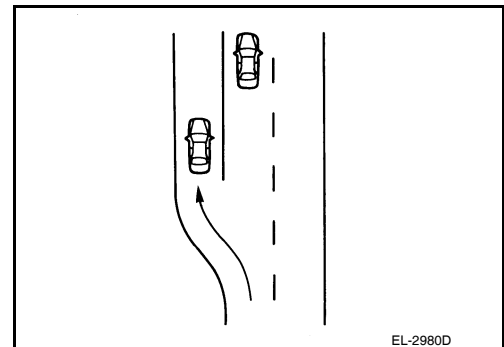

A
B
C
D
E
F
G
H
I
J
K
L
M
N
P

CCS

NORMAL OPERATING CONDITION

< SYMPTOM DIAGNOSIS >

- The sensor detection distance is limited if the vehicle-to-vehicle distance is close. The vehicle distance may not maintain properly because the motorcycle (A) driving on the lane edge is not detected or detecting the vehicle ahead (cutting in the own vehicle) delays.
- The sensor dirt is detected automatically. But it is not perfect. Dirt is not judged despite the sensor is dirt. Dirt is not detected if snow or ice is on the sensor.
Keeping the vehicle-to-vehicle distance is difficult. Drive the vehicle safely. Always clean the sensor.
Intelligent Cruise Control is released automatically if dirt is detected.

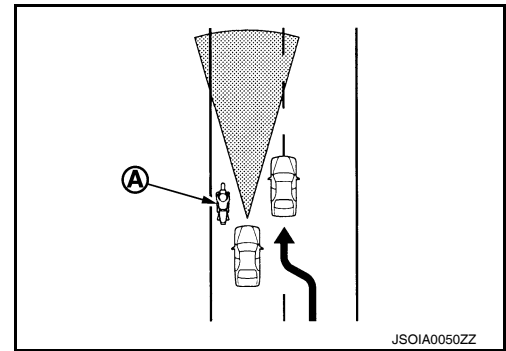

- The vehicle ahead may not be detected temporarily, the vehicle or object on the neighboring lane may be detected or the warning buzzer may sound according to the road shape (curve and narrow road) and the own vehicle condition (steering, driving lane position, accident, malfunction etc.).
The vehicle ahead is not detected temporarily. The vehicle approaches too close.

PRECAUTIONS FOR CONVENTIONAL (FIXED SPEED) CRUISE CONTROL MODE

- Conventional cruise control mode does neither control the brake nor activate the warning.
Drive the vehicle safely. Keep a safe distance between vehicles by decreasing the vehicle speed according to the driving condition etc.
- Never use the conventional cruise control mode in the following conditions.
 - A well-trafficed road, and a tight turn.
It may cause any accident because the driving does not fit to the road condition.
 - A slippery road (e.g., freezing, or snowy road)
The vehicle may lose the control by wheelspin.
 - A steep downhill
The engine brake does not activate effectively on a steep downhill. The preset vehicle speed may exceed.

PRECAUTIONS

< PRECAUTION >

PRECAUTION

PRECAUTIONS

Precaution for Supplemental Restraint System (SRS) "AIR BAG" and "SEAT BELT PRE-TENSIONER"

INFOID:000000005146018

The Supplemental Restraint System such as "AIR BAG" and "SEAT BELT PRE-TENSIONER", used along with a front seat belt, helps to reduce the risk or severity of injury to the driver and front passenger for certain types of collision. This system includes seat belt switch inputs and dual stage front air bag modules. The SRS system uses the seat belt switches to determine the front air bag deployment, and may only deploy one front air bag, depending on the severity of a collision and whether the front occupants are belted or unbelted. Information necessary to service the system safely is included in the SR and SB section of this Service Manual.

WARNING:

- To avoid rendering the SRS inoperative, which could increase the risk of personal injury or death in the event of a collision which would result in air bag inflation, all maintenance must be performed by an authorized NISSAN/INFINITI dealer.
- Improper maintenance, including incorrect removal and installation of the SRS, can lead to personal injury caused by unintentional activation of the system. For removal of Spiral Cable and Air Bag Module, see the SR section.
- Do not use electrical test equipment on any circuit related to the SRS unless instructed to in this Service Manual. SRS wiring harnesses can be identified by yellow and/or orange harnesses or harness connectors.
- When working near the Airbag Diagnosis Sensor Unit or other Airbag System sensors with the Ignition ON or engine running, DO NOT use air or electric power tools or strike near the sensor(s) with a hammer. Heavy vibration could activate the sensor(s) and deploy the air bag(s), possibly causing serious injury.
- When using air or electric power tools or hammers, always switch the Ignition OFF, disconnect the battery, and wait at least 3 minutes before performing any service.

ICC System Service

INFOID:000000005146019

- Do not look straight into the laser beam discharger when adjusting laser beam aiming.
- Turn the MAIN switch OFF in conditions similar to driving, such as free rollers or a chassis dynamometer.
- Do not use the ICC sensor integrated unit removing from vehicle. Never disassemble and remodel.
- Erase DTC when replacing parts of ICC system, then check the operation of ICC system after adjusting laser beam aiming if necessary.

A
B
C
D
E
F
G
H
I
J
K
L
M
N
P

CCS

PREPARATION

< PREPARATION >

PREPARATION

PREPARATION

Special Service Tool

INFOID:000000005146020

The actual shapes of Kent-Moore tools may differ from those of special service tools illustrated here.

Tool number (Kent-Moore No.) Tool name	Description
KV99110100 (J-45718) ICC target board  PKIA0358J	Performing laser beam aiming adjustment

ON-VEHICLE REPAIR

ICC C/U

ICC Unit

INFOID:000000005146021

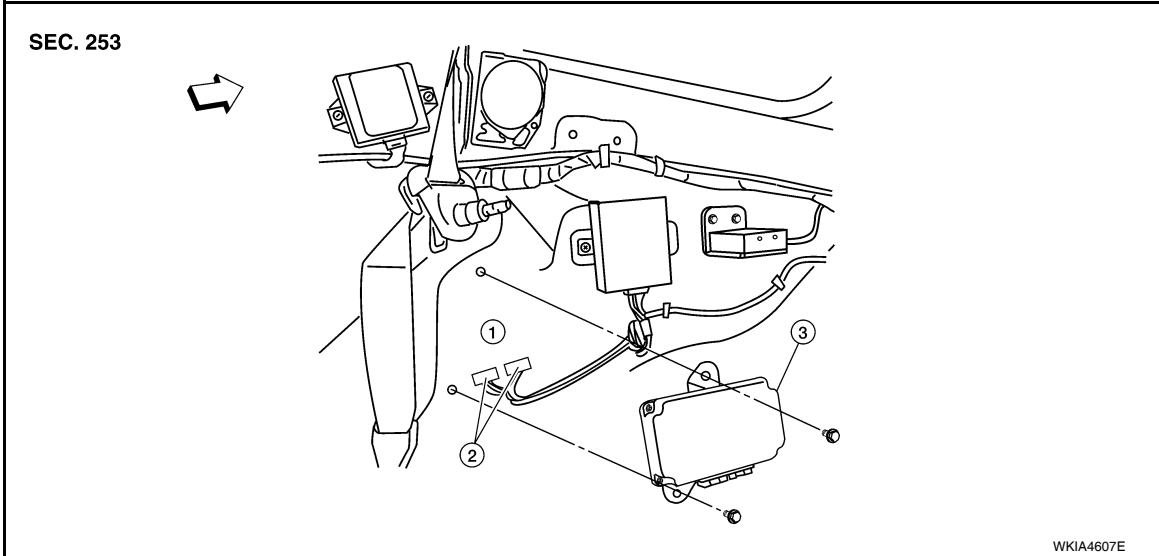

- 1. Rear inner side panel LH (shown with finisher removed)
- 2. ICC unit harness connector
- 3. ICC unit

← Vehicle front

A
B
C
D
E
F
G
H
I
J
K
L
M
N
P

CCS

ICC SENSOR INTEGRATED UNIT

< ON-VEHICLE REPAIR >

ICC SENSOR INTEGRATED UNIT

ICC Sensor

INFOID:000000005146022

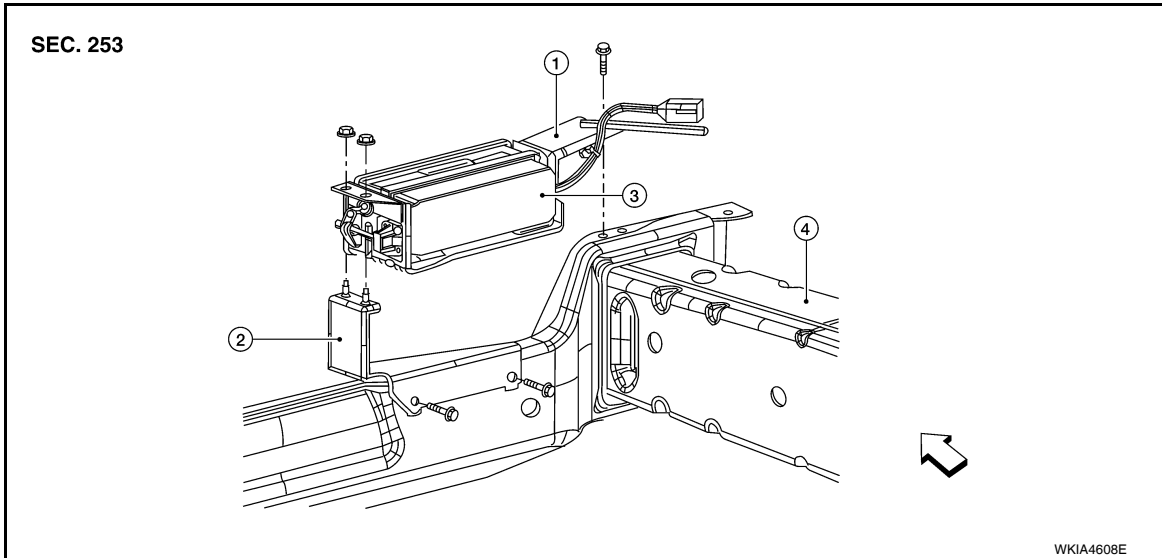

1. ICC sensor bracket

2. ICC frame bracket

3. ICC sensor

4. Frame side rail

← Vehicle front

CAUTION:

Perform the laser beam aiming procedure every time the ICC sensor is removed or installed. Refer to [CCS-5](#).

ICC STEERING SWITCH

< ON-VEHICLE REPAIR >

ICC STEERING SWITCH

Removal and Installation

INFOID:000000005146023

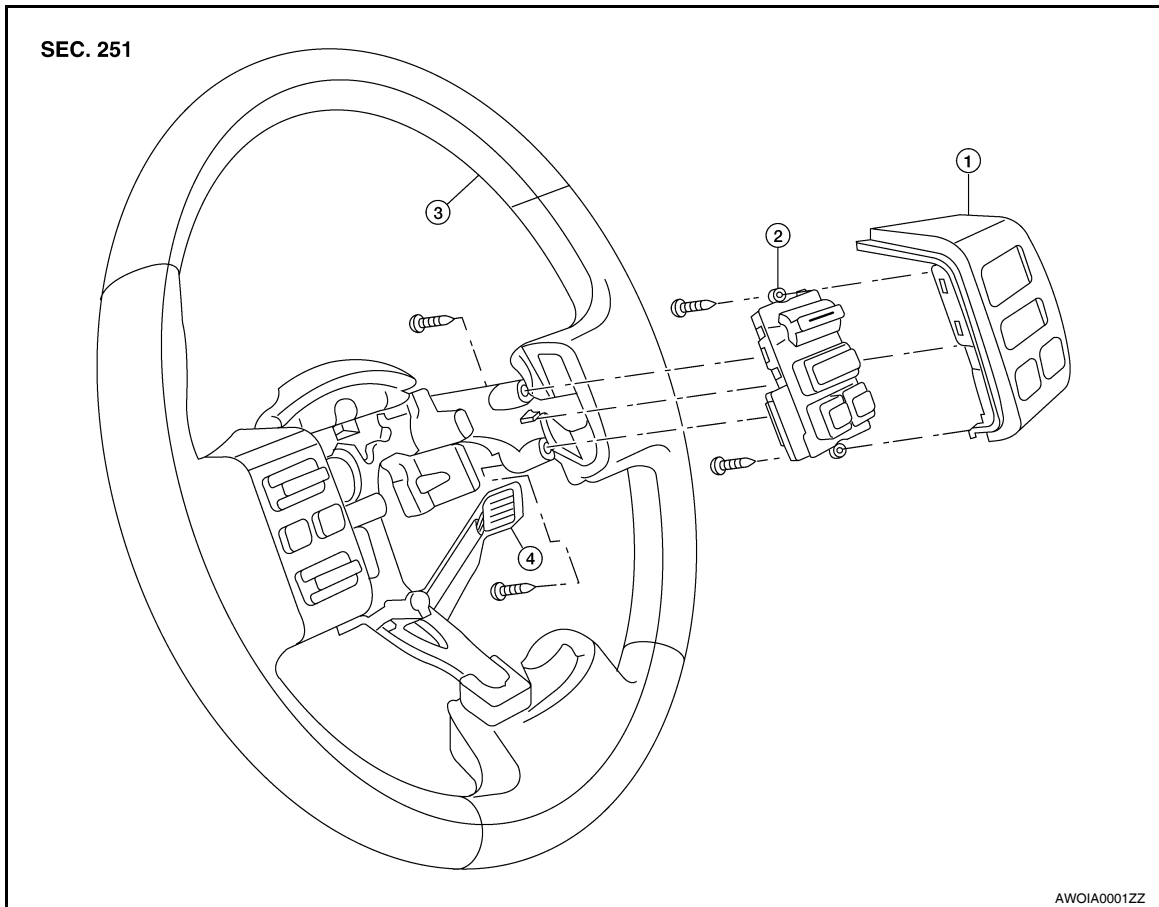

1. Steering wheel ICC switch finisher
2. Steering wheel ICC switch
3. Steering wheel
4. Steering wheel ICC switch connector

REMOVAL

1. Remove the steering wheel. Refer to [ST-18, "Removal and Installation"](#).
2. Remove the steering wheel rear cover.
3. Pull the steering wheel ICC switch out of the steering wheel, disconnect the steering wheel ICC switch connector.
4. Remove the steering wheel ICC switch finisher screws and remove the steering wheel ICC switch finisher.

INSTALLATION

Installation is in the reverse order of removal.

A
B
C
D
E
F
G
H
I
J
K
L
M
N
P

CCS