

SECTION **RAX**
REAR AXLE

A
B
C

RAX

CONTENTS

E

| | | | | |
|--|---|--|----|---|
| PRECAUTION | 2 | ON-VEHICLE REPAIR | 7 | F |
| PRECAUTIONS | 2 | REAR DRIVE SHAFT | 7 | G |
| Precaution for Supplemental Restraint System (SRS) "AIR BAG" and "SEAT BELT PRE-TENSIONER" | 2 | Component | 7 | |
| Precaution Necessary for Steering Wheel Rotation After Battery Disconnect | 2 | REMOVAL AND INSTALLATION | 8 | H |
| Precaution | 3 | WHEEL HUB | 8 | |
| PREPARATION | 4 | Removal and Installation | 8 | |
| PREPARATION | 4 | REAR DRIVE SHAFT | 10 | I |
| Special Service Tool | 4 | Removal and Installation | 10 | |
| Commercial Service Tool | 4 | DISASSEMBLY AND ASSEMBLY | 11 | J |
| SYMPTOM DIAGNOSIS | 5 | REAR DRIVE SHAFT | 11 | |
| NOISE, VIBRATION AND HARSHNESS (NVH) TROUBLESHOOTING | 5 | Disassembly and Assembly | 11 | K |
| NVH Troubleshooting Chart | 5 | SERVICE DATA AND SPECIFICATIONS (SDS) | 16 | |
| ON-VEHICLE MAINTENANCE | 6 | SERVICE DATA AND SPECIFICATIONS (SDS) | 16 | L |
| WHEEL HUB | 6 | Wheel Bearing | 16 | |
| On-Vehicle Inspection and Service | 6 | Drive Shaft | 16 | M |
| | | Boot Bands | 16 | |

F
G
H
I
J
K
L
M
N
O
P

PRECAUTIONS

< PRECAUTION >

PRECAUTION

PRECAUTIONS

Precaution for Supplemental Restraint System (SRS) "AIR BAG" and "SEAT BELT PRE-TENSIONER"

INFOID:000000005274242

The Supplemental Restraint System such as "AIR BAG" and "SEAT BELT PRE-TENSIONER", used along with a front seat belt, helps to reduce the risk or severity of injury to the driver and front passenger for certain types of collision. This system includes seat belt switch inputs and dual stage front air bag modules. The SRS system uses the seat belt switches to determine the front air bag deployment, and may only deploy one front air bag, depending on the severity of a collision and whether the front occupants are belted or unbelted. Information necessary to service the system safely is included in the SR and SB section of this Service Manual.

WARNING:

- To avoid rendering the SRS inoperative, which could increase the risk of personal injury or death in the event of a collision which would result in air bag inflation, all maintenance must be performed by an authorized NISSAN/INFINITI dealer.
- Improper maintenance, including incorrect removal and installation of the SRS, can lead to personal injury caused by unintentional activation of the system. For removal of Spiral Cable and Air Bag Module, see the SR section.
- Do not use electrical test equipment on any circuit related to the SRS unless instructed to in this Service Manual. SRS wiring harnesses can be identified by yellow and/or orange harnesses or harness connectors.

PRECAUTIONS WHEN USING POWER TOOLS (AIR OR ELECTRIC) AND HAMMERS

WARNING:

- When working near the Airbag Diagnosis Sensor Unit or other Airbag System sensors with the Ignition ON or engine running, DO NOT use air or electric power tools or strike near the sensor(s) with a hammer. Heavy vibration could activate the sensor(s) and deploy the air bag(s), possibly causing serious injury.
- When using air or electric power tools or hammers, always switch the Ignition OFF, disconnect the battery, and wait at least 3 minutes before performing any service.

Precaution Necessary for Steering Wheel Rotation After Battery Disconnect

INFOID:000000005274243

NOTE:

- This Procedure is applied only to models with Intelligent Key system and NATS (NISSAN ANTI-THEFT SYSTEM).
- Remove and install all control units after disconnecting both battery cables with the ignition knob in the "LOCK" position.
- Always use CONSULT-III to perform self-diagnosis as a part of each function inspection after finishing work. If DTC is detected, perform trouble diagnosis according to self-diagnostic results.

For models equipped with the Intelligent Key system and NATS, an electrically controlled steering lock mechanism is adopted on the key cylinder.

For this reason, if the battery is disconnected or if the battery is discharged, the steering wheel will lock and steering wheel rotation will become impossible.

If steering wheel rotation is required when battery power is interrupted, follow the procedure below before starting the repair operation.

OPERATION PROCEDURE

1. Connect both battery cables.

NOTE:

Supply power using jumper cables if battery is discharged.

2. Use the Intelligent Key or mechanical key to turn the ignition switch to the "ACC" position. At this time, the steering lock will be released.
3. Disconnect both battery cables. The steering lock will remain released and the steering wheel can be rotated.
4. Perform the necessary repair operation.

PRECAUTIONS

< PRECAUTION >

5. When the repair work is completed, return the ignition switch to the "LOCK" position before connecting the battery cables. (At this time, the steering lock mechanism will engage.)
6. Perform a self-diagnosis check of all control units using CONSULT-III.

Precaution

INFOID:000000005148950

Observe the following precautions when disassembling and servicing drive shaft.

- Perform work in a location which is as dust-free as possible.
- Before disassembling and servicing, clean the outside of parts.
- Prevention of the entry of foreign objects must be taken into account during disassembly of the service location.
- Disassembled parts must be carefully reassembled in the correct order. If work is interrupted, a clean cover must be placed over parts.
- Paper shop cloths must be used. Fabric shop cloths must not be used because of the danger of lint adhering to parts.
- Disassembled parts (except for rubber parts) should be cleaned with kerosene which shall be removed by blowing with air or wiping with paper shop cloths.

A

B

C

RAX

E

F

G

H

I

J

K

L

M

N

O

P

PREPARATION

< PREPARATION >

PREPARATION

PREPARATION

Special Service Tool

INFOID:000000005148951

The actual shapes of the Kent-Moore tools may differ from those of the special service tools illustrated here.

| Tool number (Kent-Moore No.) Tool name | Description |
|--|---|
| KV38100500 (—) Drift | Installing drive shaft plug a: 80 mm (3.15 in) dia. b: 60 mm (2.36 in) dia. |
| KV38102200 (—) Drift | Installing drive shaft plug a: 90 mm (3.54 in) dia. b: 31 mm (1.22 in) dia. |
| KV40107300 (—) Boot band crimping tool | Installing boot bands |

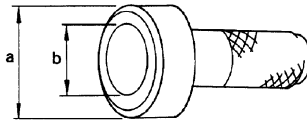

ZZA0701D

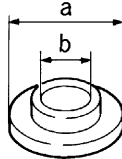

ZZA0920D

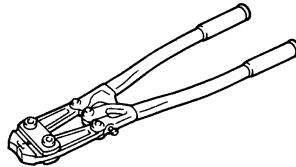

ZZA1229D

Commercial Service Tool

INFOID:000000005148952

| Tool name | Description |
|-------------|-------------------------|
| Power tools | Removing bolts and nuts |

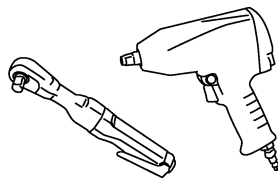

PBIC0190E

NOISE, VIBRATION AND HARSHNESS (NVH) TROUBLESHOOTING

< SYMPTOM DIAGNOSIS >

SYMPTOM DIAGNOSIS

NOISE, VIBRATION AND HARSHNESS (NVH) TROUBLESHOOTING

NVH Troubleshooting Chart

INFOID:000000005148953

Use chart below to help you find the cause of the symptom. If necessary, repair or replace these parts.

| Reference page | | Possible cause and SUSPECTED PARTS | | | | | | | | | | | | | |
|----------------|-------------------------------|------------------------------------|--------------------------|-----------|----------------------------------|--------------------|--------------|------------|------------------|-----------------|-------|------------|-----------------|--------|----------|
| | | Excessive joint angle | Joint sliding resistance | Imbalance | Improper installation, looseness | Parts interference | DIFFERENTIAL | FRONT AXLE | FRONT SUSPENSION | REAR SUSPENSION | TIRES | ROAD WHEEL | PROPELLER SHAFT | BRAKES | STEERING |
| Symptom | Noise | x | x | | x | x | x | x | x | | x | x | x | x | x |
| | Shake | x | | x | x | x | | x | x | | x | x | x | x | x |
| | Vibration | | | | x | x | | x | x | x | x | x | | | x |
| | Shimmy | | | | x | x | | x | x | | x | x | | x | x |
| | Shudder | | | | x | | | x | x | | x | x | | x | x |
| | Poor quality ride or handling | | | | x | x | | x | x | x | x | x | | | x |

x: Applicable

A
B
C
RAX
E
F
G
H
I
J
K
L
M
N
O
P

WHEEL HUB

< ON-VEHICLE MAINTENANCE >

ON-VEHICLE MAINTENANCE

WHEEL HUB

On-Vehicle Inspection and Service

INFOID:000000005148954

Inspect the components for any looseness or back lash. Inspect each component for any excessive wear or damage. Replace any components as necessary.

WHEEL BEARING INSPECTION

- Move the wheel hub and bearing assembly in the axial direction by hand to check the axial end play. Check that the axial end play is with specification. Replace the wheel hub and bearing assembly as necessary.

Axial end play : 0 mm (0 in)

- Rotate the wheel hub and bearing assembly to check that there are no unusual noises or other abnormal conditions. Replace the wheel hub and bearing assembly as necessary.

REAR DRIVE SHAFT

< ON-VEHICLE REPAIR >

ON-VEHICLE REPAIR

REAR DRIVE SHAFT

Component

INFOID:000000005148955

Rear Drive Shaft

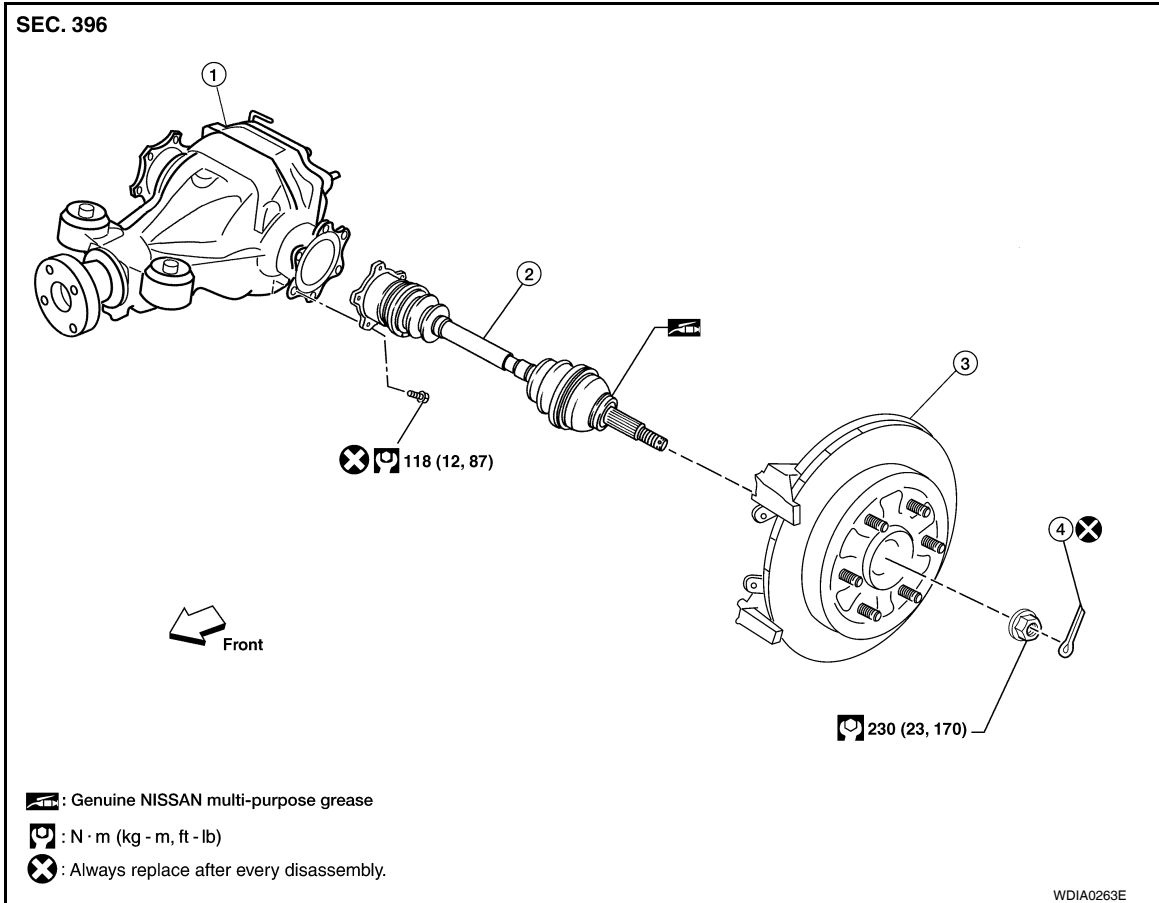

1. Rear final drive assembly
2. Rear drive shaft
3. Rear brake and hub assembly
4. Cotter pin

WHEEL HUB

< REMOVAL AND INSTALLATION >

REMOVAL AND INSTALLATION

WHEEL HUB

Removal and Installation

INFOID:000000005148956

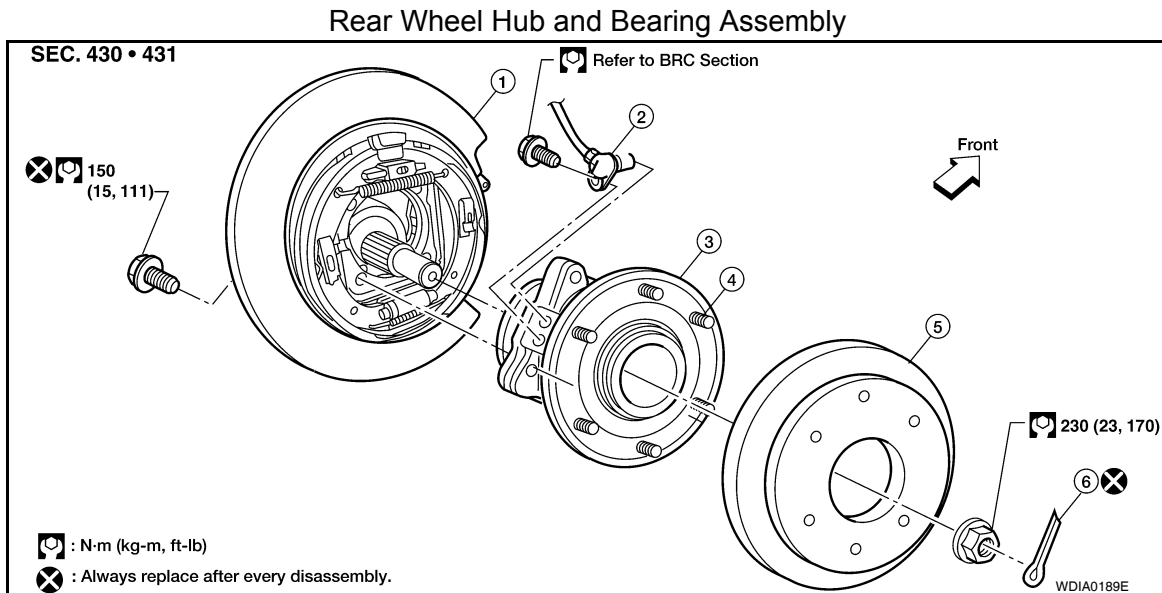

1. Back plate
2. Rear ABS sensor
3. Wheel hub and bearing assembly
4. Wheel stud
5. Rear disc rotor
6. Cotter pin

NOTE:

The rear ABS sensor is routed through the back of the rear backing plate and into the side of the wheel hub and bearing assembly. It is necessary to remove the wheel hub and bearing assembly to remove the rear ABS sensor.

REMOVAL

1. Remove the wheel and tire using power tool.
2. Remove the rear brake caliper, without disconnecting the hydraulic hose, using power tool. Reposition the rear brake caliper aside using suitable wire. Refer to [BR-36, "Removal and Installation of Brake Caliper and Disc Rotor"](#).

NOTE:

- Do not depress the brake pedal while the brake caliper is removed.

3. Remove the rear disc rotor.
4. Remove the cotter pin, then remove the nut from the drive shaft using power tool.
 - Discard the cotter pin, use a new one for installation.
5. Remove the drive shaft. Refer to [RAX-10, "Removal and Installation"](#).

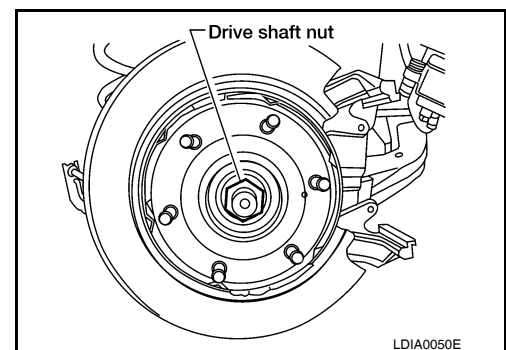

6. Remove the four wheel hub and bearing assembly bolts using power tool.
 - Discard the four wheel hub and bearing assembly bolts, use new ones for installation.

WHEEL HUB

< REMOVAL AND INSTALLATION >

7. Pull out the wheel hub and bearing assembly for access to remove the rear ABS sensor from the wheel hub and bearing assembly as shown.
 - Inspect the ABS sensor O-ring, replace the ABS sensor assembly if damaged.
 - Clean the ABS sensor hole and mounting surface with a suitable brake cleaner and a clean lint-free shop rag. Be careful that dirt and debris do not enter the axle bearing area.
 - Apply a coat of suitable grease to the ABS sensor O-ring and mounting hole.

CAUTION:

Do not pull on the ABS harness.

8. Remove the wheel hub and bearing assembly.

INSTALLATION

Installation is in the reverse order of removal.

- Apply grease 44003 7S000 to contact surface between wheel hub and drive shaft. Use sufficient grease to completely coat contact area.
- Inspect the ABS sensor O-ring, replace the ABS sensor assembly if damaged.
- Clean the ABS sensor hole and mounting surface with a suitable brake cleaner and a clean lint-free shop rag. Be careful that dirt and debris do not enter the axle bearing area.
- Apply a coat of suitable grease to the ABS sensor O-ring and mounting hole.
- Use a new cotter pin for installation.
- Use new wheel hub and bearing assembly bolts for installation.

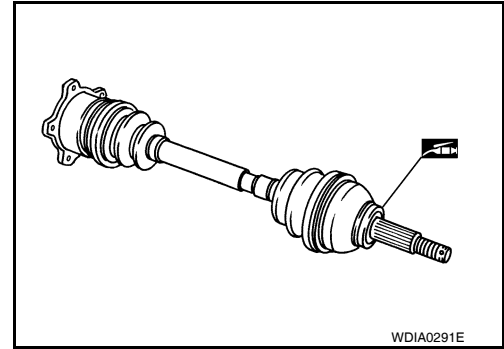
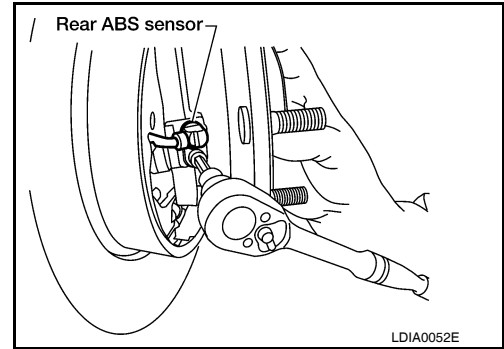

A
B
C
RAX
E
F
G
H
I
J
K
L
M
N
O
P

REAR DRIVE SHAFT

< REMOVAL AND INSTALLATION >

REAR DRIVE SHAFT

Removal and Installation

INFOID:000000005148957

REMOVAL

1. Remove the wheel and tire using power tool.
2. Remove the stabilizer bar clamp. Refer to [RSU-9, "Component"](#).
3. Remove the cotter pin and discard, then remove the drive shaft nut from the drive shaft.
 - Do not reuse the cotter pin, discard after removal and use a new cotter pin for installation.

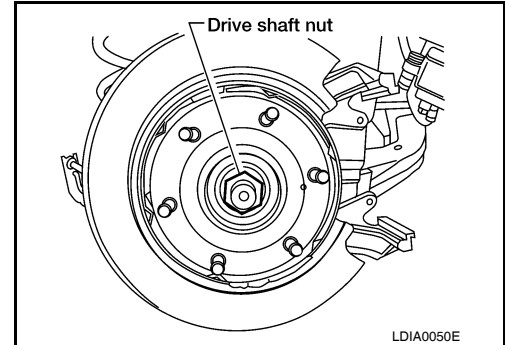

4. Remove the six bolts from the inside flange of the drive shaft using power tool.
 - Do not reuse the drive shaft inside flange bolts, discard after removal and use new bolts for installation.
5. Separate the drive shaft from the wheel hub and bearing assembly by lightly tapping the end with a suitable hammer and wood block. If it is difficult to separate, use a suitable puller.
6. Remove the drive shaft.

CAUTION:

When removing the drive shaft, do not bend at an excessive angle to the drive shaft joint. Do not excessively extend the slide joint.

INSPECTION AFTER REMOVAL

- Move the joint up and down, left and right, and in the axial direction. Check for any rough movement or significant looseness.
- Check the boot for cracks or other damage, and for any grease leakage.
- If necessary, disassemble the drive shaft, and repair as necessary.

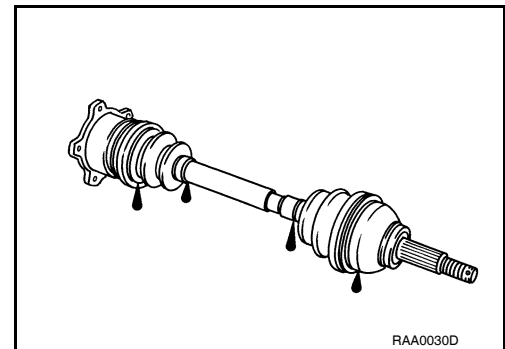

INSTALLATION

Installation is in the reverse order of removal.

- Do not reuse the drive shaft inside flange bolts, discard after removal and use new bolts for installation.
- Do not reuse the cotter pin, discard after removal and use a new cotter pin for installation.

Drive shaft lock nut : Refer to [RAX-7, "Component"](#).

Drive shaft inside flange bolts : Refer to [RAX-7, "Component"](#).

REAR DRIVE SHAFT

< DISASSEMBLY AND ASSEMBLY >

DISASSEMBLY AND ASSEMBLY

REAR DRIVE SHAFT

Disassembly and Assembly

INFOID:000000005274245

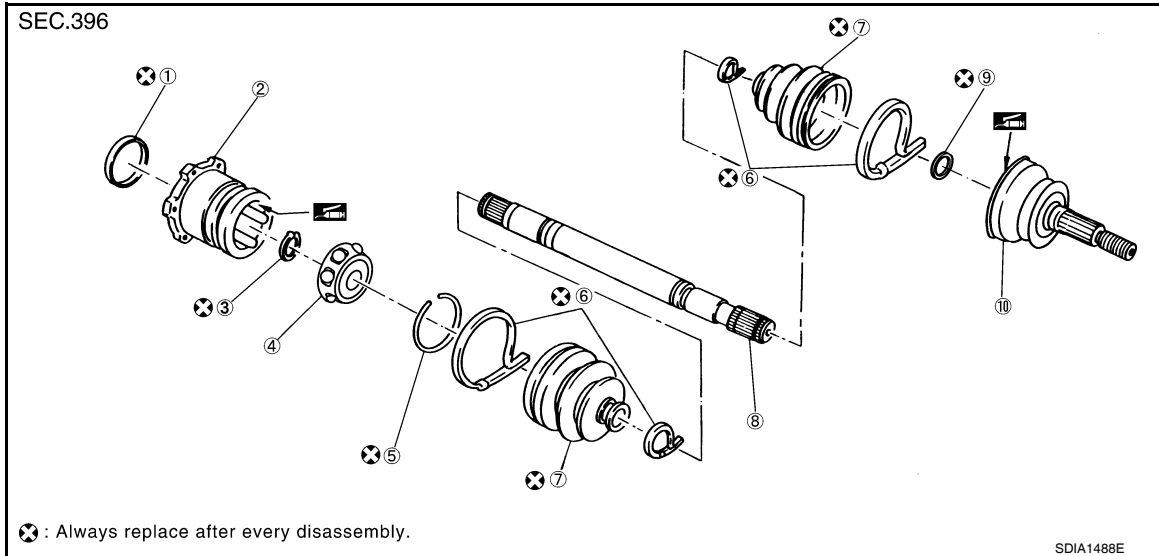

- | | | |
|---|-----------------|--------------|
| 1. Plug | 2. Housing | 3. Snap ring |
| 4. Ball cage, steel ball, inner race assembly | 5. Stopper ring | 6. Boot band |
| 7. Boot | 8. Shaft | 9. Circlip |
| 10. Joint sub-assembly | | |

DISASSEMBLY

Final Drive Side

- Secure the drive shaft in a vise.
CAUTION:
When securing the drive shaft in a vise, use copper or aluminum plates between the vise and the drive shaft.
- Remove the boot bands.
- If the plug needs to be removed, move the boot to the wheel side, then drive the plug out using a suitable tool.
- Remove the stopper ring using a suitable tool as shown, and pull the housing out.

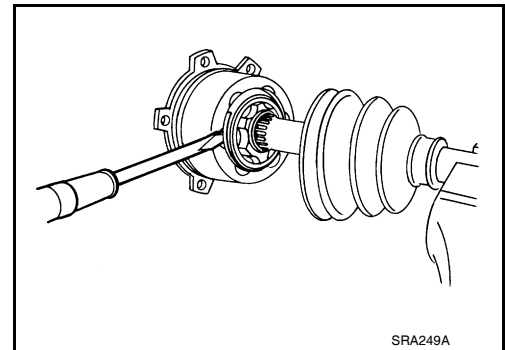

REAR DRIVE SHAFT

< DISASSEMBLY AND ASSEMBLY >

5. Remove the snap ring using a suitable tool, then remove the ball cage, steel ball, inner race assembly from the drive shaft.

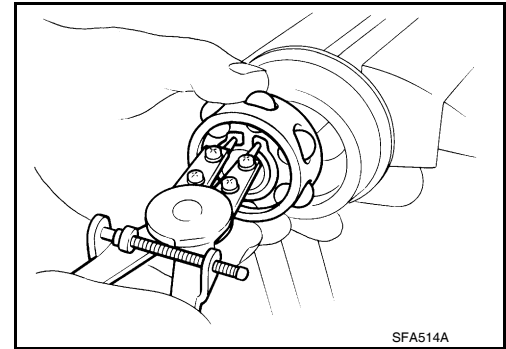

6. Remove the boot from the drive shaft.
7. Remove any old grease on the housing using paper towels.

Wheel Side

1. Secure the drive shaft in a vise.

CAUTION:

When securing the drive shaft in a vise, use copper or aluminum plates between the vise and the drive shaft.

2. Remove the boot bands, then remove the boot from the joint sub-assembly.
3. Screw a suitable drive shaft puller 30 mm (1.18 in) or more into the threaded part of the joint sub-assembly. Pull the joint sub-assembly out of the drive shaft as shown.

CAUTION:

- If the joint sub-assembly cannot be removed after five or more attempts, replace the drive shaft and joint sub-assembly as a set.
- Align the sliding hammer and drive shaft and remove the joint sub-assembly by pulling directly.

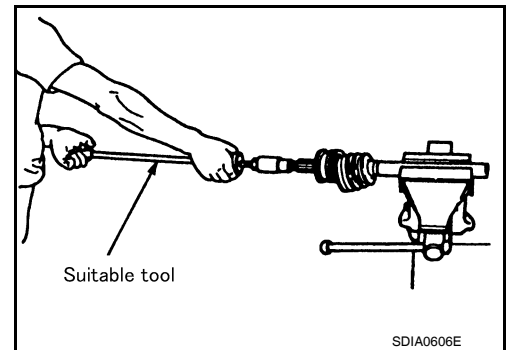

4. Remove the boot from the drive shaft.
5. Remove the circlip from the drive shaft.
6. While rotating the ball cage, remove any old grease on the joint sub-assembly using paper towels.

INSPECTION AFTER DISASSEMBLY

Drive Shaft

- Replace the drive shaft if there is any runout, cracking, or other damage.

Joint Sub-assembly

- Check for any rough rotation or unusual axial looseness.
- Clean any foreign material from inside the joint sub-assembly.
- Check for any compression scars, cracks, or fractures.

CAUTION:

If any defective conditions are found in the joint sub-assembly components, replace the entire joint sub-assembly.

Sliding Joint Side (Housing)

- Check for any compression scars, cracks, fractures, or unusual wear on the ball rolling surface.
- Check for any damage to the drive shaft screws.
- Check for any deformation of the boot installation components.

Ball Cage

- Check the sliding surface for any compression scars, cracks, or fractures.

Steel Ball

- Check for any compression scars, cracks, fractures, or unusual wear.

Inner Race

REAR DRIVE SHAFT

< DISASSEMBLY AND ASSEMBLY >

- Check the ball sliding surface for any compression scars, cracks, or fractures.
- Check for any damage to the serrated part.

CAUTION:

If any defective conditions are found, install a new housing, ball cage, steel ball, and inner race as a set.

ASSEMBLY

Final Drive Side

1. If the plug has been removed, use Tool to press in a new one.

Tool number : KV38100500 (—)
 : KV38102200 (—)

NOTE:

Discard the old plug and use a new one for assembly.

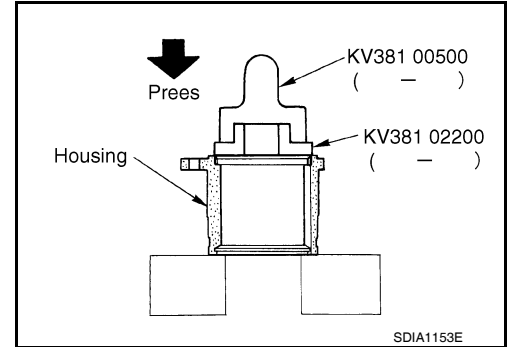

2. Wrap the serrated part of the shaft with tape. Install the boot band and boot to shaft.

NOTE:

Discard the old boot band and boot and use a new one for assembly.

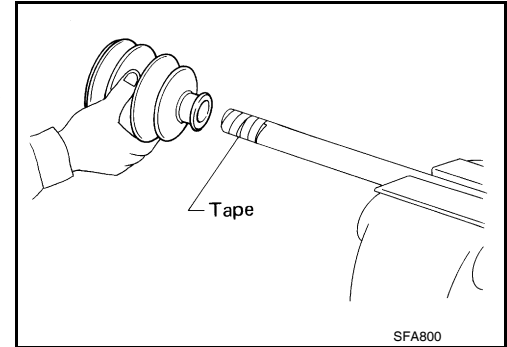

3. Remove the tape wound around the serrated part of the shaft.
4. Install the ball cage, steel ball, and inner race assembly on the shaft, and secure them tightly using the snap ring.

NOTE:

Discard the old snap ring and use a new one for assembly.

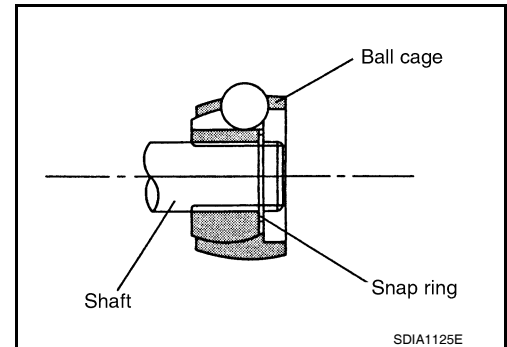

5. Insert the specified quantity of Genuine NISSAN Grease or equivalent, onto the housing (indicated by * marks), and install it onto shaft. Refer to [MA-13, "Fluids and Lubricants"](#).

Grease capacity : 175 – 195 g (6.17 – 6.88 oz)

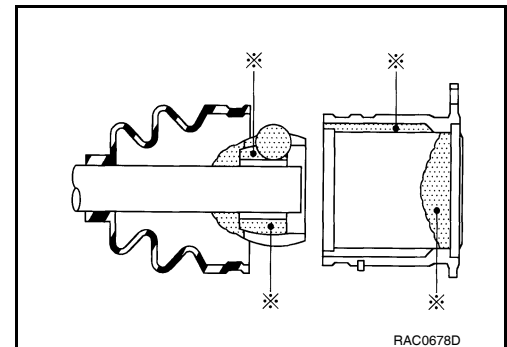

6. Install the stopper ring onto the housing.

A
B
C
RAX
E
F
G
H
I
J
K
L
M
N
O
P

REAR DRIVE SHAFT

< DISASSEMBLY AND ASSEMBLY >

- After installation, pull on the shaft to check engagement between the joint sub-assembly and the stopper ring.

- Install the boot securely into the grooves (indicated by * marks) as shown.

CAUTION:

If there is grease on boot mating surfaces (indicated by * marks) of shaft and housing, boot may come off. Remove all grease from surfaces.

- Check that the boot installation length (L) is the length indicated below. Insert a suitable tool into large side of the boot. Bleed the air from the boot to prevent any boot deformation.

Boot installation length (L) : 147.9 mm (5.82 in)

CAUTION:

- The boot may break if the boot installation length is less than the specified value.
- Do not touch the tip of the tool to the inside of the boot.

- Secure the large and small ends of the boot with the new boot bands as shown.

NOTE:

Discard the old boot bands and use new ones for assembly.

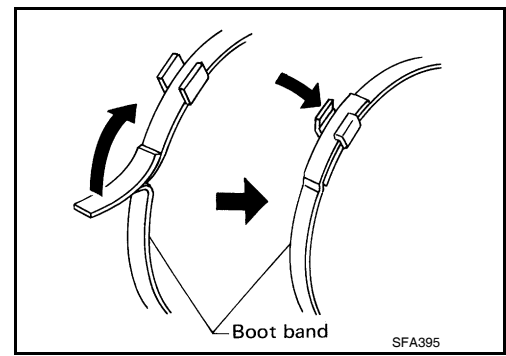
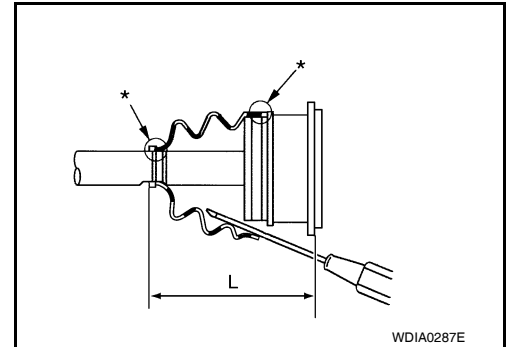

- After installing the housing and shaft, rotate the boot to check that the boot is positioned correctly. If the boot is not positioned correctly, reposition the boot and secure the boot using a new boot band.

Wheel Side

- Insert the Genuine NISSAN Grease or equivalent, into the joint sub-assembly serration hole until the grease begins to ooze from the ball groove and serration hole. Refer to [MA-13, "Fluids and Lubricants"](#). After inserting the grease, use a shop cloth to wipe off the grease that has oozed out.

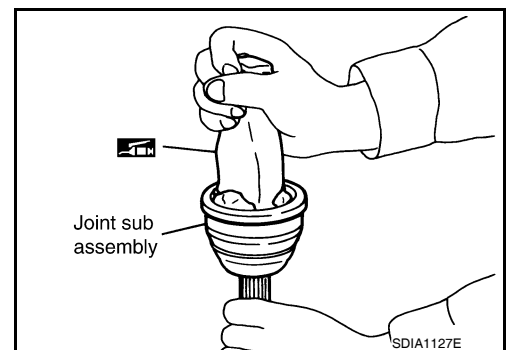

- Wind the serrated part of the shaft with tape. Install the boot band and boot onto the shaft. Do not damage the boot.

NOTE:

Discard the old boot band and boot and use a new one for assembly.

- Remove the protective tape wound around the serrated part of the shaft.

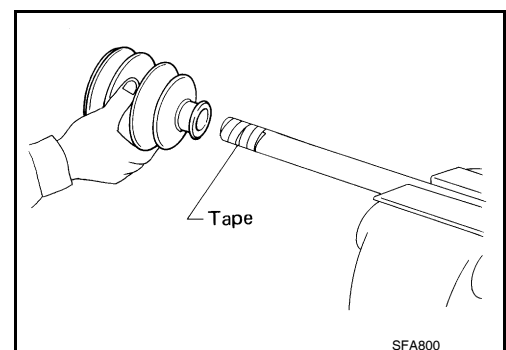

REAR DRIVE SHAFT

< DISASSEMBLY AND ASSEMBLY >

4. Attach the circlip to the shaft. The circlip must fit securely into the shaft groove. Attach the nut to the joint sub-assembly. Use a suitable tool to press-fit the circlip.

NOTE:

Discard the old circlip and use a new one for assembly.

5. Insert the specified quantity of Genuine NISSAN Grease or equivalent, into the housing from the large end of the boot. Refer to [MA-13, "Fluids and Lubricants"](#).

Grease capacity : 140 – 160 g (4.93 – 5.64 oz)

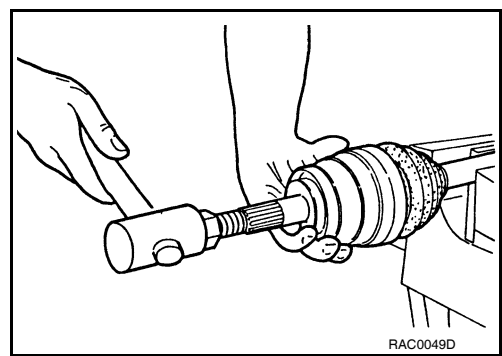

6. Install the boot securely into the grooves (indicated by the * marks) as shown.

CAUTION:

If there is grease on the boot mating surfaces (indicated by the * marks) of the shaft and housing, the boot may come off. Remove all grease from the shaft surfaces.

7. Check that the boot installation length (L) is the specified length. Insert a flat-tip screwdriver or similar tool into the large end of the boot. Bleed the air from the boot to prevent boot deformation.

Boot installation length (L) : 134.5 mm (5.30 in)

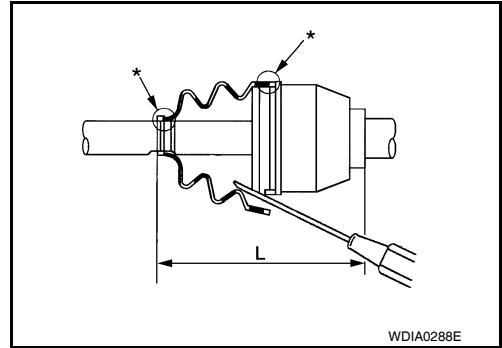

CAUTION:

- The boot may break if the boot installation length is less than the specified length.
- Do not contact inside surface of boot with the tip of the screwdriver.

8. Secure large and small ends of the boot using new boot bands using tool as shown.

Tool number : KV40107300 (—)

NOTE:

Discard the old boot bands and use new ones for assembly.

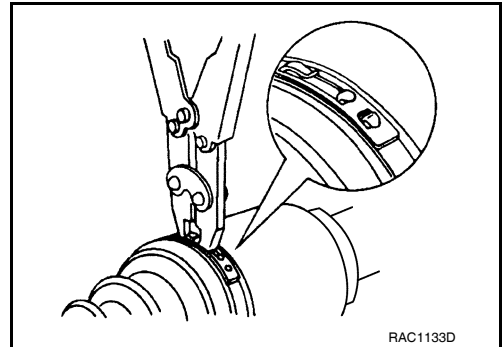

- Secure boot band so that dimension (M) meets specification as shown.

Dimension (M) : 1.0 – 4.0 mm (0.039 – 0.157 in)

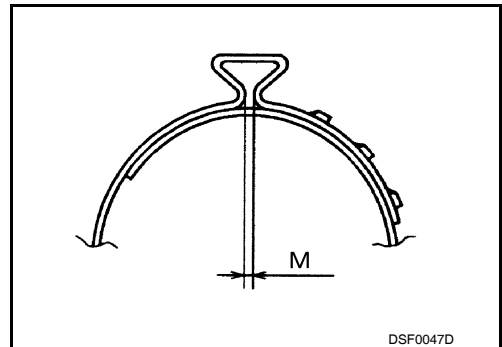

9. After installing the housing to the shaft, rotate the boot to check that it is positioned correctly. If the boot is not positioned correctly, remove the old boot bands then reposition the boot and secure the boot with new boot bands.

A
B
C
RAX
E
F
G
H
I
J
K
L
M
N
O
P

SERVICE DATA AND SPECIFICATIONS (SDS)

< SERVICE DATA AND SPECIFICATIONS (SDS)

SERVICE DATA AND SPECIFICATIONS (SDS)

SERVICE DATA AND SPECIFICATIONS (SDS)

Wheel Bearing

INFOID:000000005148959

| | |
|----------------|-------------|
| Axial end play | 0 mm (0 in) |
|----------------|-------------|

Drive Shaft

INFOID:000000005148960

| Joint | Wheel side | Final drive side |
|-----------------------|---------------------------------|---------------------------------|
| Grease capacity | 140 – 160 g (4.93 – 5.64 oz) | 175 – 195 g (6.17 – 6.88 oz) |
| Boot installed length | 134.5 mm (5.30 in) | 147.9 mm (5.82 in) |

Boot Bands

INFOID:000000005148961

Unit: mm (in)

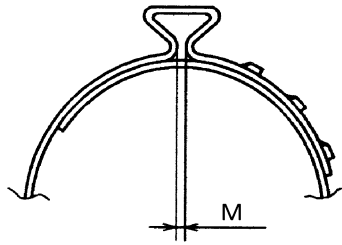

DSF0047D

| | |
|---------------|---------------------------|
| Dimension (M) | 1.0 - 4.0 (0.039 - 0.157) |
|---------------|---------------------------|