

SECTION **EXT**
EXTERIOR

A
B
C
D
E
F
G
H
I
J
L
M
N
O
P

CONTENTS

PRECAUTION	3	FENDER PROTECTOR	23
PRECAUTIONS	3	FENDER PROTECTOR : Exploded View	23
Precaution for Supplemental Restraint System (SRS) "AIR BAG" and "SEAT BELT PRE-TENSIONER"	3	FENDER PROTECTOR : Removal and Installation	23
Precaution Necessary for Steering Wheel Rotation after Battery Disconnect	3	REAR WHEEL HOUSE PROTECTOR	23
Precaution for Procedure without Cowl Top Cover.....	4	REAR WHEEL HOUSE PROTECTOR : Exploded View	24
Precaution for Work	4	REAR WHEEL HOUSE PROTECTOR : Removal and Installation	24
PREPARATION	5	FLOOR SIDE FAIRING	25
PREPARATION	5	Exploded View	25
Commercial Service Tools	5	Removal and Installation	25
SYMPTOM DIAGNOSIS	6	OVER FENDER	26
SQUEAK AND RATTLE TROUBLE DIAGNOSES	6	Exploded View	26
Work Flow	6	Removal and Installation	26
Inspection Procedure	8	ROOF RAIL	29
Diagnostic Worksheet	10	Exploded View	29
REMOVAL AND INSTALLATION	12	Removal and Installation	29
FRONT BUMPER	12	ROOF SIDE MOLDING	31
Exploded View	12	Exploded View	31
Removal and Installation	13	Removal and Installation	31
REAR BUMPER	16	DOOR OUTSIDE MOLDING	32
Exploded View	16	Exploded View	32
Removal and Installation	17	Removal and Installation	32
FRONT GRILLE	19	DOOR PARTING SEAL	34
Exploded View	19	Exploded View	34
Removal and Installation	19	Removal and Installation	34
COWL TOP	21	SILL MOLDING	36
Exploded View	21	Exploded View	36
Removal and Installation	21	Removal and Installation	36
FENDER PROTECTOR	23	DOOR SASH COVER	37
		Exploded View	37
		Removal and Installation	37

EXT

FRONT PILLAR FINISHER	40	Removal and Installation	43
Exploded View	40		
Removal and Installation	40		
REAR SPOILER	41	BACK DOOR FINISHER	44
Exploded View	41	Exploded View	44
Removal and Installation	41	Removal and Installation	44
DRIP MOLDING	43	SIDE STEP	45
Exploded View	43	Exploded View	45
		Removal and Installation	45

PRECAUTIONS

< PRECAUTION >

PRECAUTION

PRECAUTIONS

Precaution for Supplemental Restraint System (SRS) "AIR BAG" and "SEAT BELT PRE-TENSIONER"

INFOID:000000006367589

The Supplemental Restraint System such as "AIR BAG" and "SEAT BELT PRE-TENSIONER", used along with a front seat belt, helps to reduce the risk or severity of injury to the driver and front passenger for certain types of collision. This system includes seat belt switch inputs and dual stage front air bag modules. The SRS system uses the seat belt switches to determine the front air bag deployment, and may only deploy one front air bag, depending on the severity of a collision and whether the front occupants are belted or unbelted. Information necessary to service the system safely is included in the "SRS AIR BAG" and "SEAT BELT" of this Service Manual.

WARNING:

- To avoid rendering the SRS inoperative, which could increase the risk of personal injury or death in the event of a collision that would result in air bag inflation, all maintenance must be performed by an authorized NISSAN/INFINITI dealer.
- Improper maintenance, including incorrect removal and installation of the SRS, can lead to personal injury caused by unintentional activation of the system. For removal of Spiral Cable and Air Bag Module, see the "SRS AIR BAG".
- Do not use electrical test equipment on any circuit related to the SRS unless instructed to in this Service Manual. SRS wiring harnesses can be identified by yellow and/or orange harnesses or harness connectors.

PRECAUTIONS WHEN USING POWER TOOLS (AIR OR ELECTRIC) AND HAMMERS

WARNING:

- When working near the Air Bag Diagnosis Sensor Unit or other Air Bag System sensors with the ignition ON or engine running, DO NOT use air or electric power tools or strike near the sensor(s) with a hammer. Heavy vibration could activate the sensor(s) and deploy the air bag(s), possibly causing serious injury.
- When using air or electric power tools or hammers, always switch the ignition OFF, disconnect the battery, and wait at least 3 minutes before performing any service.

Precaution Necessary for Steering Wheel Rotation after Battery Disconnect

INFOID:000000006367590

NOTE:

- Before removing and installing any control units, first turn the push-button ignition switch to the LOCK position, then disconnect both battery cables.
- After finishing work, confirm that all control unit connectors are connected properly, then re-connect both battery cables.
- Always use CONSULT-III to perform self-diagnosis as a part of each function inspection after finishing work. If a DTC is detected, perform trouble diagnosis according to self-diagnosis results.

For vehicle with steering lock unit, if the battery is disconnected or discharged, the steering wheel will lock and cannot be turned.

If turning the steering wheel is required with the battery disconnected or discharged, follow the operation procedure below before starting the repair operation.

OPERATION PROCEDURE

1. Connect both battery cables.

NOTE:

Supply power using jumper cables if battery is discharged.

2. Turn the push-button ignition switch to ACC position.
(At this time, the steering lock will be released.)
3. Disconnect both battery cables. The steering lock will remain released with both battery cables disconnected and the steering wheel can be turned.
4. Perform the necessary repair operation.

A

B

C

D

E

F

G

H

I

J

EXT

L

M

N

O

P

PRECAUTIONS

< PRECAUTION >

5. When the repair work is completed, re-connect both battery cables. With the brake pedal released, turn the push-button ignition switch from ACC position to ON position, then to LOCK position. (The steering wheel will lock when the push-button ignition switch is turned to LOCK position.)
6. Perform self-diagnosis check of all control units using CONSULT-III.

Precaution for Procedure without Cowl Top Cover

INFOID:000000006367591

When performing the procedure after removing cowl top cover, cover the lower end of windshield with urethane, etc.

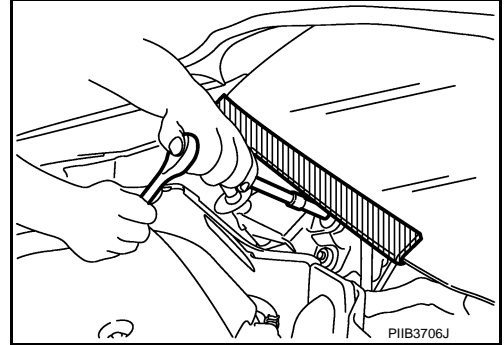

Precaution for Work

INFOID:000000006367592

- After removing and installing the opening/closing parts, be sure to carry out fitting adjustments to check their operation.
- Check the lubrication level, damage, and wear of each part. If necessary, grease or replace it.

PREPARATION



< PREPARATION >

PREPARATION

PREPARATION

Commercial Service Tools

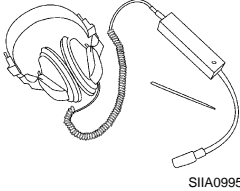
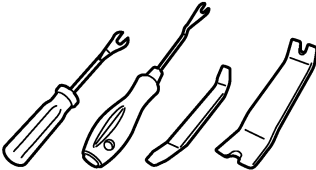
INFOID:000000006367593

Tool name	Description
<p data-bbox="159 516 269 543">Engine ear</p>  <p data-bbox="776 632 841 646">SIIA0995E</p>	<p data-bbox="1008 516 1187 543">Locates the noise</p>
<p data-bbox="159 768 293 795">Remover tool</p>  <p data-bbox="776 884 862 898">JMKIA3050ZZ</p>	<p data-bbox="1008 768 1382 795">Removes clips, pawls and metal clips</p>
<p data-bbox="159 1020 269 1047">Power tool</p>  <p data-bbox="776 1136 841 1150">PIIB1407E</p>	

A

B

C

D

E

F

G

H

I

J

EXT

L

M

N

O

P

SQUEAK AND RATTLE TROUBLE DIAGNOSES

< SYMPTOM DIAGNOSIS >

SYMPTOM DIAGNOSIS

SQUEAK AND RATTLE TROUBLE DIAGNOSES

Work Flow

INFOID:000000006367800

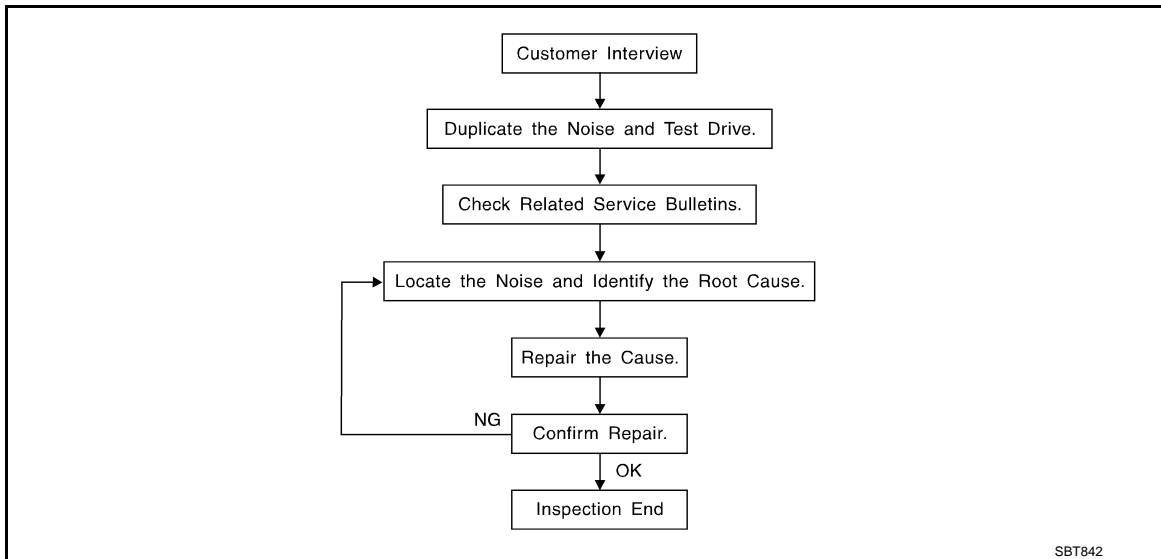

CUSTOMER INTERVIEW

Interview the customer if possible, to determine the conditions that exist when the noise occurs. Use the Diagnostic Worksheet during the interview to document the facts and conditions when the noise occurs and any customer comments. Refer to [EXT-10. "Diagnostic Worksheet"](#). This information is necessary to duplicate the conditions that exist when the noise occurs.

- The customer may not be able to provide a detailed description or the location of the noise. Attempt to obtain all the facts and conditions that exist when the noise occurs (or does not occur).
- If there is more than one noise in the vehicle, perform a diagnosis and repair the noise that the customer is concerned about. This can be accomplished by performing a test drive with the customer.
- After identifying the type of noise, isolate the noise in terms of its characteristics. The noise characteristics are provided so that the customer, service adviser, and technician use the same language when describing the noise.
- Squeak – (Like tennis shoes on a clean floor)
Squeak characteristics include the light contact / fast movement / brought on by road conditions / hard surfaces = high-pitched noise / softer surfaces = low-pitched noises / edge to surface = chirping
- Creak – (Like walking on an old wooden floor)
Creak characteristics include firm contact / slow movement/twisting with a rotational movement / pitch dependent on materials / often brought on by activity.
- Rattle – (Like shaking a baby rattle)
Rattle characteristics include fast repeated contact / vibration or similar movement / loose parts/missing clip or fastener / incorrect clearance.
- Knock – (Like a knock on a door)
Knock characteristics include hollow sounds / sometimes repeating / often brought on by driver action.
- Tick – (Like a clock second hand)
Tick characteristics include gentle contacting of light materials / loose components / can be caused by driver action or road conditions.
- Thump – (Heavy, muffled knock noise)
Thump characteristics include softer knock / dull sounds often brought on by activity.
- Buzz – (Like a bumblebee)
Buzz characteristics include high frequency rattle / firm contact.
- Often the degree of acceptable noise level varies depending upon the person. A noise that a technician may judge as acceptable may be very irritating to a customer.
- Weather conditions, especially humidity and temperature, may have a great effect on noise level.

DUPLICATE THE NOISE AND TEST DRIVE

SQUEAK AND RATTLE TROUBLE DIAGNOSES

< SYMPTOM DIAGNOSIS >

If possible, drive the vehicle with the customer until the noise is duplicated. Note any additional information on the Diagnostic Worksheet regarding the conditions or location of the noise. This information can be used to duplicate the same conditions when the repair is reconfirmed.

If the noise can be duplicated easily during the test drive, to help identify the source of the noise, try to duplicate the noise with the vehicle stopped by doing one or all of the following items:

- 1) Close a door.
 - 2) Tap or push/pull around the area where the noise appears to be coming from.
 - 3) Rev the engine.
 - 4) Use a floor jack to recreate vehicle "twist".
 - 5) At idle, apply engine load (electrical load, half-clutch on M/T models, drive position on A/T models).
 - 6) Raise the vehicle on a hoist and hit a tire with a rubber hammer.
- Drive the vehicle and attempt to duplicate the conditions the customer states exist when the noise occurs.
 - If it is difficult to duplicate the noise, drive the vehicle slowly on an undulating or rough road to stress the vehicle body.

CHECK RELATED SERVICE BULLETINS

After verifying the customer concern or symptom, check ASIST for Technical Service Bulletins (TSBs) related to the concern or symptom.

If a TSB relates to the symptom, follow the procedure to repair the noise.

LOCATE THE NOISE AND IDENTIFY THE ROOT CAUSE

1. Narrow down the noise to a general area. To help pinpoint the source of the noise, use a listening tool (Chassis ear: J-39570, engine ear, and mechanics stethoscope).
2. Narrow down the noise to a more specific area and identify the cause of the noise by:
 - Removing the component(s) in the area that is / are suspected to be the cause of the noise. Do not use too much force when removing clips and fasteners, otherwise clips and fasteners can be broken or lost during the repair, resulting in the creation of new noise.
 - Tapping or pushing/pulling the component(s) that is / are suspected to be the cause of the noise. Do not tap or push/pull the component(s) with excessive force, otherwise the noise is eliminated only temporarily.
 - Feeling for a vibration by hand by touching the component(s) that is / are suspected to be the cause of the noise.
 - Placing a piece of paper between components that are suspected to be the cause of the noise.
 - Looking for loose components and contact marks.
Refer to [EXT-8. "Inspection Procedure"](#).

REPAIR THE CAUSE

- If the cause is a loose component, tighten the component securely.
- If the cause is insufficient clearance between components:
 - Separate components by repositioning or loosening and retightening the components, if possible.
 - Insulate components with a suitable insulator such as urethane pads, foam blocks, felt cloth tape, or urethane tape. A NISSAN Squeak and Rattle Kit (J-43980) is available through the authorized NISSAN Parts Department.

CAUTION:

Never use excessive force as many components are constructed of plastic and may be damaged.

NOTE:

Always check with the Parts Department for the latest parts information.

The following materials are contained in the NISSAN Squeak and Rattle Kit (J-43980). Each item can be ordered separately as needed.

URETHANE PADS [1.5 mm (0.059 in) thick]

Insulates connectors, harness, etc.

- 76268-9E005: 100 × 135 mm (3.937 × 5.315 in)
- 76884-71L01: 60 × 85 mm (2.362 × 3.346 in)
- 76884-71L02: 15 × 25 mm (0.591 × 0.984 in)

INSULATOR (Foam blocks)

Insulates components from contact. Can be used to fill space behind a panel.

- 73982-9E000: 45 mm (1.772 in) thick, 50 × 50 mm (1.969 × 1.969 in)
- 73982-50Y00: 10 mm (0.394 in) thick, 50 × 50 mm (1.969 × 1.969 in)

INSULATOR (Light foam block)

80845-71L00: 30 mm (1.181 in) thick, 30 × 50 mm (1.181 × 1.969 in)

FELT CLOTHTAPE

SQUEAK AND RATTLE TROUBLE DIAGNOSES

< SYMPTOM DIAGNOSIS >

Used to insulate where movement does not occur. Ideal for instrument panel applications.

- 68370-4B000: 15 × 25 mm (0.591 × 0.984 in) pad
- 68239-13E00: 5 mm (0.197 in) wide tape roll

The following materials, not found in the kit, can also be used to repair squeaks and rattles.

UHMW (TEFLON) TAPE

Insulates where slight movement is present. Ideal for instrument panel applications.

SILICONE GREASE

Used in place of UHMW tape that is visible or does not fit. Only lasts a few months.

SILICONE SPRAY

Used when grease cannot be applied.

DUCT TAPE

Used to eliminate movement.

CONFIRM THE REPAIR

After repair is complete, test drive the vehicle to confirm that the cause of noise is repaired by test driving the vehicle. Operate the vehicle under the same conditions as when the noise originally occurred. Refer to the notes on the Diagnostic Worksheet.

Inspection Procedure

INFOID:000000006367801

Refer to Table of Contents for specific component removal and installation information.

INSTRUMENT PANEL

Most incidents are caused by contact and movement between:

1. The cluster lid A and instrument panel
2. Acrylic lens and combination meter housing
3. Instrument panel to front pillar garnish
4. Instrument panel to windshield
5. Instrument panel mounting pins
6. Wiring harnesses behind the combination meter
7. A/C defroster duct and duct joint

These incidents can usually be located by tapping or moving the components to duplicate the noise or by pressing on the components while driving to stop the noise. Most of these incidents can be repaired by applying felt cloth tape or silicon spray (in hard to reach areas). Urethane pads can be used to insulate wiring harness.

CAUTION:

Never use silicone spray to isolate a squeak or rattle. If the area is saturated with silicone, the recheck of repair becomes impossible.

CENTER CONSOLE

Components to check include:

1. Shifter assembly cover to finisher
2. A/C control unit and cluster lid C
3. Wiring harnesses behind audio and A/C control unit

The instrument panel repair and isolation procedures also apply to the center console.

DOORS

Check the following items:

1. Finisher and inner panel making a slapping noise
2. Inside handle escutcheon connection to door finisher
3. Wiring harnesses tapping
4. Door striker out of alignment causing a popping noise on starts and stops

Tapping, moving the components, or pressing on them while driving to duplicate the conditions can isolate many of these incidents. The areas can usually be insulated with felt cloth tape or insulator foam blocks from the NISSAN Squeak and Rattle Kit (J-43980) to repair the noise.

TRUNK

Trunk noises are often caused by a loose jack or loose items put into the trunk by the customer.

In addition check for the following items:

SQUEAK AND RATTLE TROUBLE DIAGNOSES

< SYMPTOM DIAGNOSIS >

1. Trunk lid dumpers out of adjustment
2. Trunk lid striker out of adjustment
3. Trunk lid torsion bars knocking together
4. A loose license plate or bracket

Most of these incidents can be repaired by adjusting, securing, or insulating the item(s) or component(s) causing the noise.

SUNROOF/HEADLINING

Noises in the sunroof / headlining area can often be traced to one of the following items:

1. Sunroof lid, rail, linkage, or seals making a rattle or light knocking noise
2. Sunvisor shaft shaking in the holder
3. Front or rear windshield touching headlining and squeaking

Again, pressing on the components to stop the noise while duplicating the conditions can isolate most of these incidents. Repairs usually consist of insulating with felt cloth tape.

SEATS

When isolating seat noise it is important to note the position the seat is in and the load placed on the seat when the noise occurs. These conditions should be duplicated when verifying and isolating the cause of the noise.

Causes of seat noise include:

1. Headrest rods and holder
2. A squeak between the seat pad cushion and frame
3. The rear seatback lock and bracket

These noises can be isolated by moving or pressing on the suspected components while duplicating the conditions under which the noise occurs. Most of these incidents can be repaired by repositioning the component or applying urethane tape to the contact area.

UNDERHOOD

Some interior noise may be caused by components under the hood or on the engine wall. The noise is then transmitted into the passenger compartment.

Causes of transmitted underhood noise include:

1. Any component mounted to the engine wall
2. Components that pass through the engine wall
3. Engine wall mounts and connectors
4. Loose radiator mounting pins
5. Hood bumpers out of adjustment
6. Hood striker out of adjustment

These noises can be difficult to isolate since they cannot be reached from the interior of the vehicle. The best method is to secure, move, or insulate one component at a time and test drive the vehicle. Also, engine RPM or load can be changed to isolate the noise. Repairs can usually be made by moving, adjusting, securing, or insulating the component causing the noise.

A
B
C
D
E
F
G
H
I
J
L
M
N
O
P

EXT

SQUEAK AND RATTLE TROUBLE DIAGNOSES

< SYMPTOM DIAGNOSIS >

Diagnostic Worksheet

INFOID:00000006367802



SQUEAK & RATTLE DIAGNOSTIC WORKSHEET

Dear Infiniti Customer:

We are concerned about your satisfaction with your Infiniti vehicle. Repairing a squeak or rattle sometimes can be very difficult. To help us fix your Infiniti right the first time, please take a moment to note the area of the vehicle where the squeak or rattle occurs and under what conditions. You may be asked to take a test drive with a service consultant or technician to ensure we confirm the noise you are hearing.

I. WHERE DOES THE NOISE COME FROM? (circle the area of the vehicle)

The illustrations are for reference only, and may not reflect the actual configuration of your vehicle.

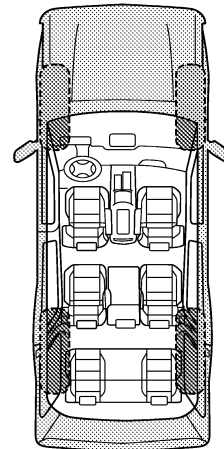
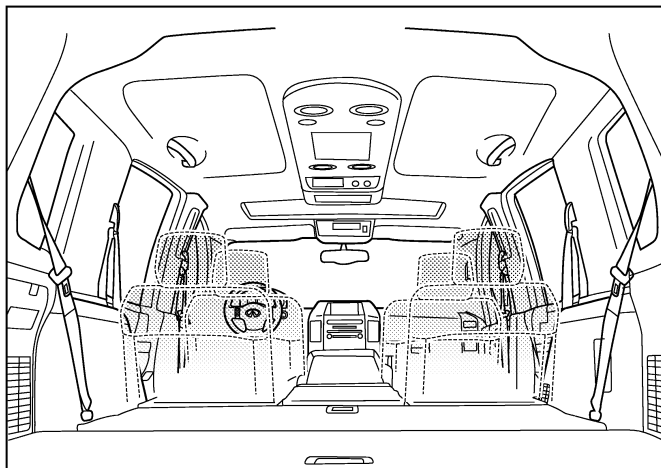
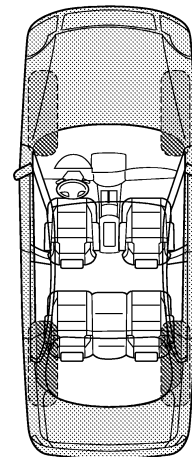
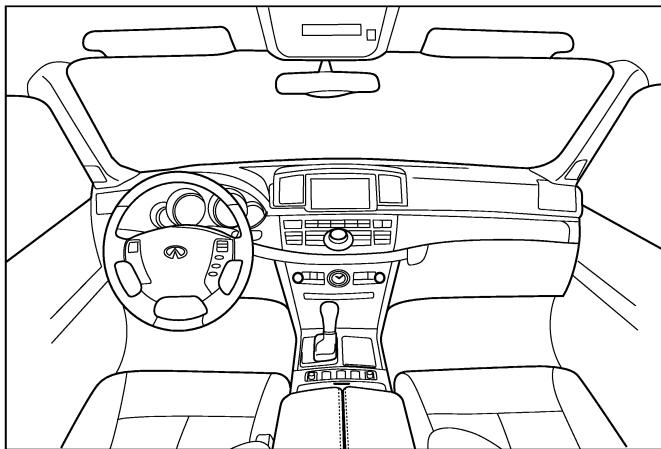

Continue to page 2 of the worksheet and briefly describe the location of the noise or rattle. In addition, please indicate the conditions which are present when the noise occurs.

PIIB8741E

SQUEAK AND RATTLE TROUBLE DIAGNOSES

< SYMPTOM DIAGNOSIS >

SQUEAK & RATTLE DIAGNOSTIC WORKSHEET - page 2

Briefly describe the location where the noise occurs:

II. WHEN DOES IT OCCUR? (please check the boxes that apply)

- | | |
|---|--|
| <input type="checkbox"/> anytime | <input type="checkbox"/> after sitting out in the rain |
| <input type="checkbox"/> 1st time in the morning | <input type="checkbox"/> when it is raining or wet |
| <input type="checkbox"/> only when it is cold outside | <input type="checkbox"/> dry or dusty conditions |
| <input type="checkbox"/> only when it is hot outside | <input type="checkbox"/> other: |

III. WHEN DRIVING:

- through driveways
- over rough roads
- over speed bumps
- only about ____ mph
- on acceleration
- coming to a stop
- on turns: left, right or either (circle)
- with passengers or cargo
- other: _____
- after driving ____ miles or ____ minutes

IV. WHAT TYPE OF NOISE

- squeak (like tennis shoes on a clean floor)
- creak (like walking on an old wooden floor)
- rattle (like shaking a baby rattle)
- knock (like a knock at the door)
- tick (like a clock second hand)
- thump (heavy, muffled knock noise)
- buzz (like a bumble bee)

TO BE COMPLETED BY DEALERSHIP PERSONNEL

Test Drive Notes:

	YES	NO	Initials of person performing
Vehicle test driven with customer	<input type="checkbox"/>	<input type="checkbox"/>	_____
- Noise verified on test drive	<input type="checkbox"/>	<input type="checkbox"/>	_____
- Noise source located and repaired	<input type="checkbox"/>	<input type="checkbox"/>	_____
- Follow up test drive performed to confirm repair	<input type="checkbox"/>	<input type="checkbox"/>	_____

VIN: _____ Customer Name: _____
W.O.# _____ Date: _____

This form must be attached to Work Order

PIIB8742E

A
B
C
D
E
F
G
H
I
J
L
M
N
O
P

EXT

FRONT BUMPER

< REMOVAL AND INSTALLATION >

REMOVAL AND INSTALLATION

FRONT BUMPER

Exploded View

INFOID:000000006367597

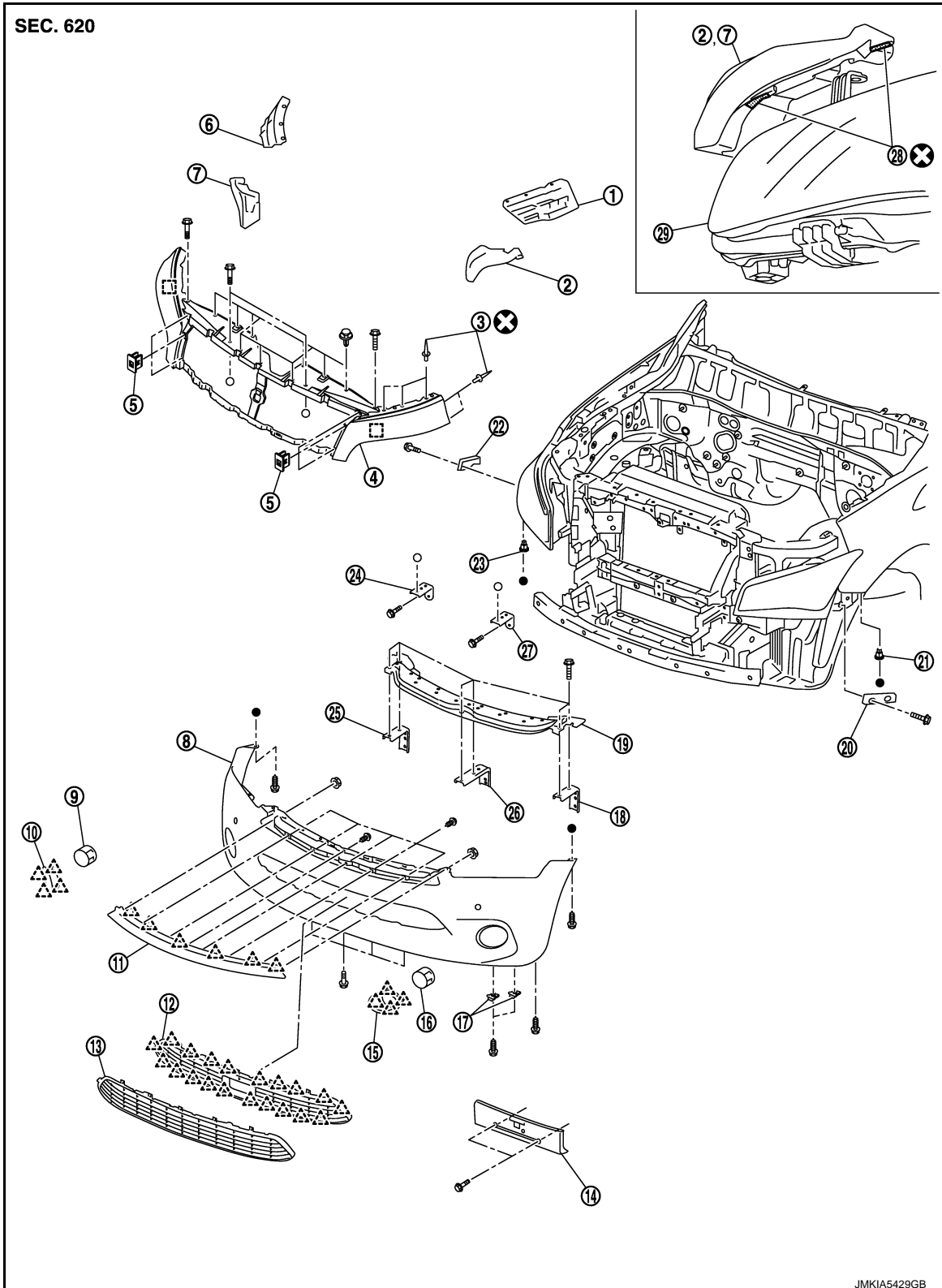

FRONT BUMPER

< REMOVAL AND INSTALLATION >

- | | | | |
|--|---------------------------------|------------------------------------|--|
| 1. Bumper molding bracket LH | 2. Energy absorber LH | 3. Rivet | |
| 4. Bumper molding | 5. Grommet | 6. Bumper molding bracket RH | |
| 7. Energy absorber RH | 8. Bumper fascia assembly | 9. Front fog lamp RH | |
| 10. Front fog lamp finisher RH | 11. Front grille lower molding | 12. Front bumper grille (with ICC) | |
| 13. Front bumper grille (without ICC) | 14. License plate bracket | 15. Front fog lamp finisher LH | |
| 16. Front fog lamp LH | 17. U nut | 18. Bumper retainer bracket LH | |
| 19. Bumper retainer | 20. Bumper side bracket LH | 21. Grommet | |
| 22. Bumper side bracket RH | 23. Grommet | 24. Bumper molding stay RH | |
| 25. Bumper retainer bracket RH | 26. Bumper retainer bracket CTR | 27. Bumper molding stay LH | |
| 28. double-sided tape
[t: 0.13 mm (0.005 in)] | | | |

 : Pawl

 : Metal clip

Removal and Installation

INFOID:000000006367598

REMOVAL

CAUTION:

Bumper fascia is made of resin. Never apply strong force to it, and be careful to prevent contact with oil.

- Fully open hood assembly.
- Remove front grille. Refer to [EXT-19, "Removal and Installation"](#).
- Remove bumper molding.
 - Remove front fender drip cover. Refer to [DLK-223, "FRONT FENDER DRIP COVER : Removal and Installation"](#).
 - Remove bumper molding upper fixing screws (A) (LH and RH).

 : Vehicle front

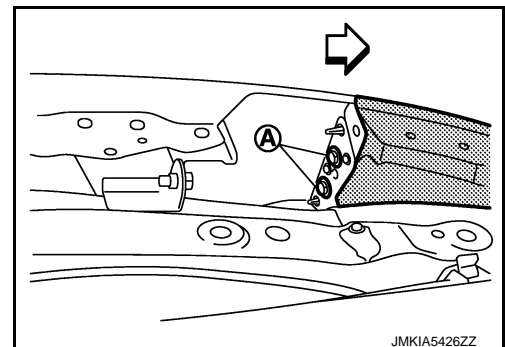

- Remove bumper molding fixing clips (A).

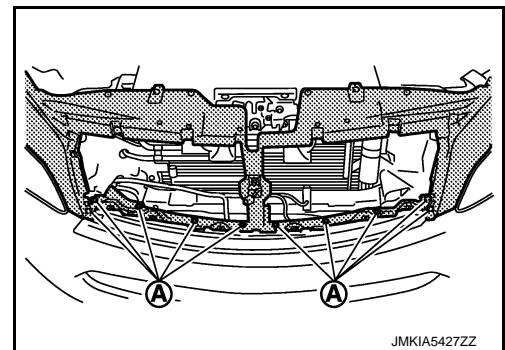

FRONT BUMPER

< REMOVAL AND INSTALLATION >

4. Pull bumper molding (1) toward the direction shown in the figure, and then disengage bumper molding fixing metal clips (LH and RH).

 : Metal clip

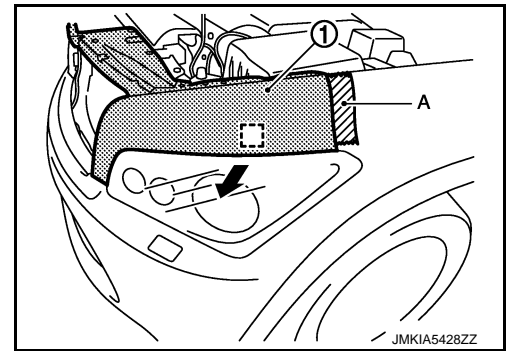

5. Remove bumper molding.
4. Remove front over fender front side. Refer to [EXT-26, "Removal and Installation"](#).
5. Remove clips of bumper upper side.
6. Remove bumper fascia assembly fixing screws (A) (LH and RH).

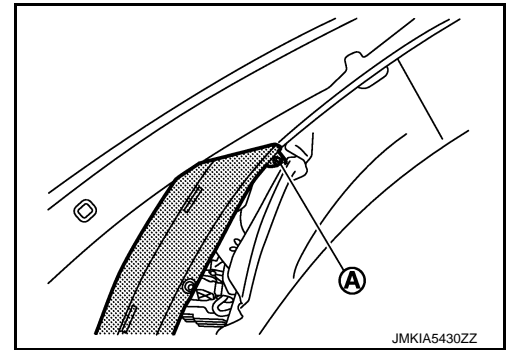

7. Pull bumper fascia assembly toward the vehicle outside as shown by the arrow in the figure, and then disengage the bumper fascia assembly from bumper side brackets (LH and RH).

 : Pawl

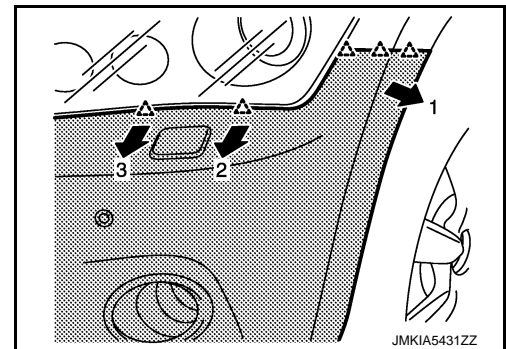

8. Disconnect corner sensor harness connector and fog lamp harness connector.
9. Remove bumper fascia assembly.

CAUTION:

When removing bumper fascia assembly, 2 workers are required so as to prevent it from dropping.

10. Remove the following parts after removing bumper fascia assembly.
 - Front grille lower molding.
 - Front bumper grille.
 - Sonar sensor (LH and RH). Refer to [AV-239, "Removal and Installation"](#).
 - Front fog lamp assembly (LH and RH). Refer to [EXL-128, "Removal and Installation"](#).
 - Front fog lamp finishers (LH and RH)
 - Bumper side bracket (LH and RH)
 - License plate bracket
11. Remove bumper upper retainer.

INSTALLATION

Note the following item, and then install in the reverse order of removal.

NOTE:

FRONT BUMPER

< REMOVAL AND INSTALLATION >

- The following table shows the specified values for checking normal installation status.
- Fitting adjustment cannot be performed.

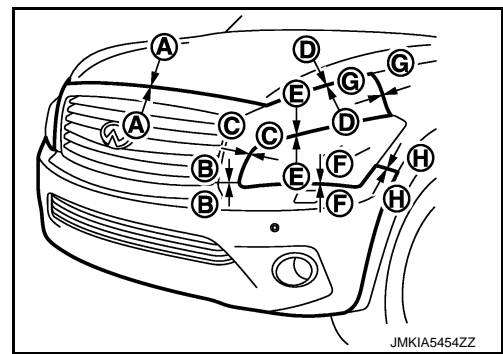

Portion		Clearance	Surface height difference
Front grille – Hood	A – A	3.7 – 8.3 mm (0.146 – 0.327 in)	(-0.9) – (+3.9) mm [(-0.035) – (+0.154) in]
Bumper fascia assembly – Front bumper molding	B – B	0.1 – 3.4 mm (0.004 – 0.134 in)	(-1.9) – (+1.9) mm [(-0.075) – (+0.075) in]
Front bumper molding – Headlamp	C – C	0.1 – 2.5 mm (0.004 – 0.098 in)	—
Front bumper molding – Hood	D – D	1.2 – 5.8 mm (0.047 – 0.228 in)	(-2.4) – (+2.4) mm [(-0.094) – (+0.094) in]
Front bumper molding – Headlamp	E – E	0.1 – 2.5 mm (0.004 – 0.098 in)	—
Bumper fascia assembly – Headlamp	F – F	0.2 – 3.1 mm (0.008 – 0.122 in)	0.5 – 3.5 mm (0.020 – 0.138 in)
Front fender – Front bumper molding	G – G	0.0 – 0.7 mm (0.000 – 0.028 in)	(-1.0) – (+1.0) mm [(-0.039) – (+0.039) in]
Front fender – Bumper fascia assembly	H – H	0.0 – 0.8 mm (0.000 – 0.031 in)	(-0.7) – (+1.3) mm [(-0.028) – (+0.051) in]

A
B
C
D
E
F
G
H
I
J
EXT
L
M
N
O
P

REAR BUMPER

< REMOVAL AND INSTALLATION >

REAR BUMPER

Exploded View

INFOID:000000006367599

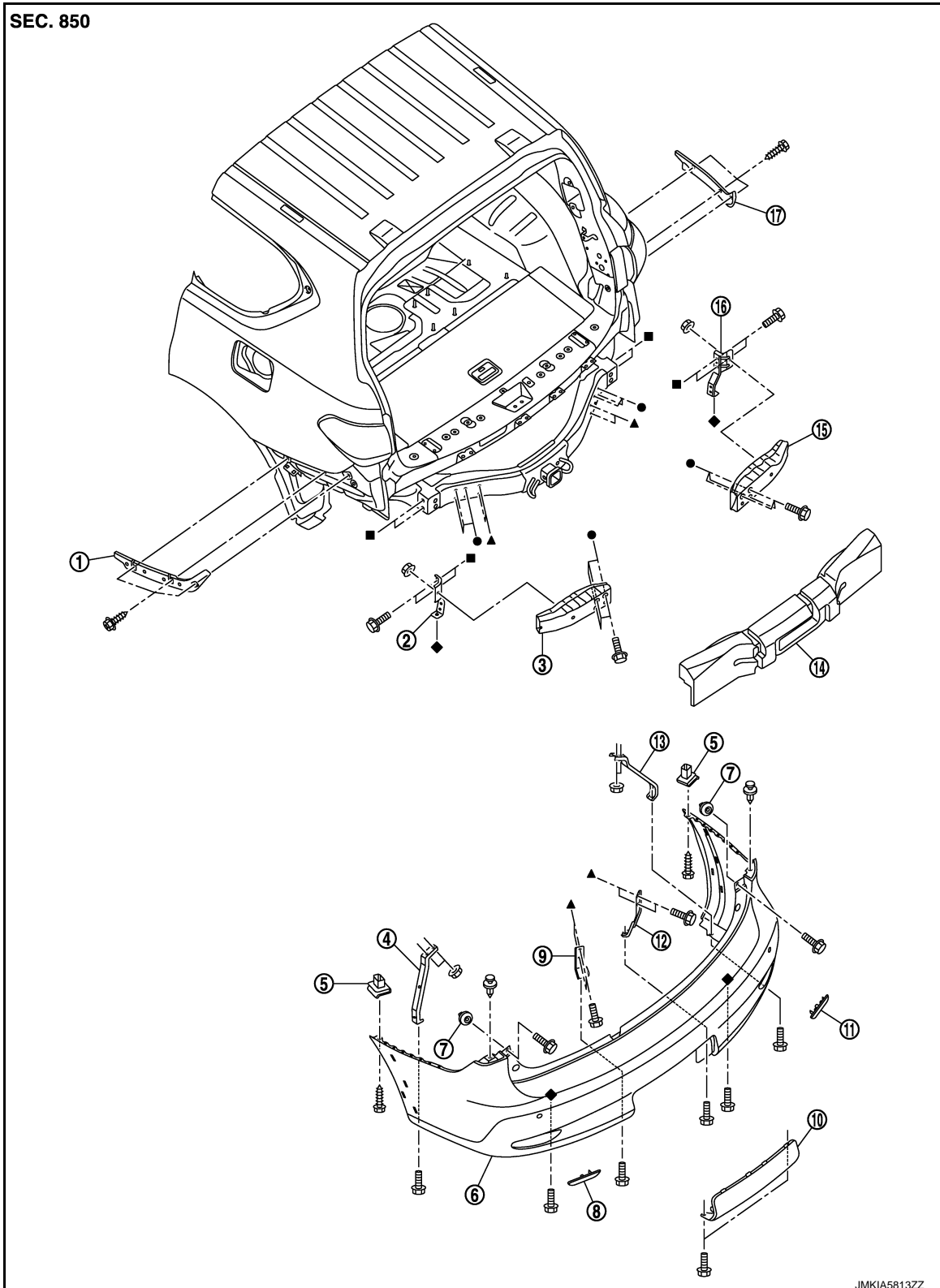

- | | | |
|---------------------------|------------------------|---------------------------------|
| 1. Bumper side bracket LH | 2. Bumper stay LH | 3. Bumper side reinforcement LH |
| 4. Bumper side stay LH | 5. Grommet | 6. Bumper fascia assembly |
| 7. Grommet | 8. Reflex reflector LH | 9. Bumper stay LH |

REAR BUMPER

< REMOVAL AND INSTALLATION >

- | | | |
|---------------------------|----------------------------|----------------------------------|
| 10. Bumper lower finisher | 11. Reflex reflector RH | 12. Bumper stay RH |
| 13. Bumper side stay RH | 14. Energy absorber | 15. Bumper side reinforcement RH |
| 16. Bumper stay RH | 17. Bumper side bracket RH | |

Removal and Installation

INFOID:000000006367600

REMOVAL

CAUTION:

Bumper fascia is made of resin. Never apply strong force to it, and be careful to prevent contact with oil.

1. Fully open back door assembly.
2. Remove rear combination lamp (LH and RH). Refer to [EXL-138, "Removal and Installation"](#).
3. Remove bumper fascia fixing clips (A) and screws (B) (LH and RH).

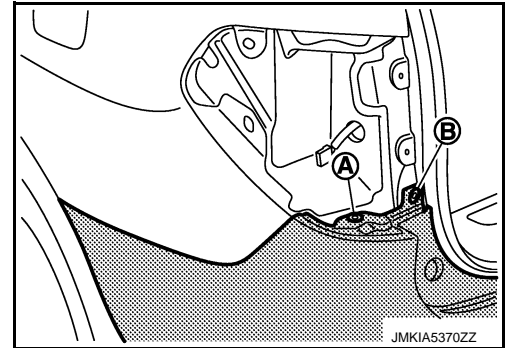

4. Remove rear over fender fixing screws.
5. Remove bumper fascia lower mounting bolts.
6. Remove screws (A) of bumper fascia front end upper (LH and RH).

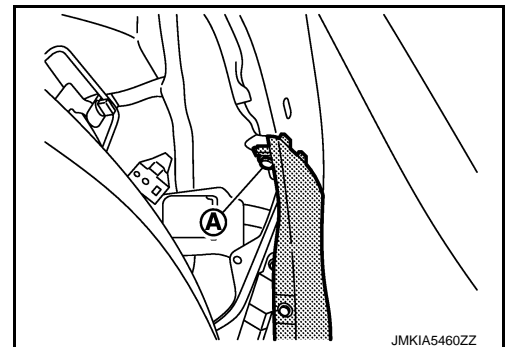

7. Pull bumper fascia assembly toward the vehicle outside as shown by the arrow in the figure, and then disengage the bumper fascia assembly from bumper side brackets (LH and RH).

 : Pawl

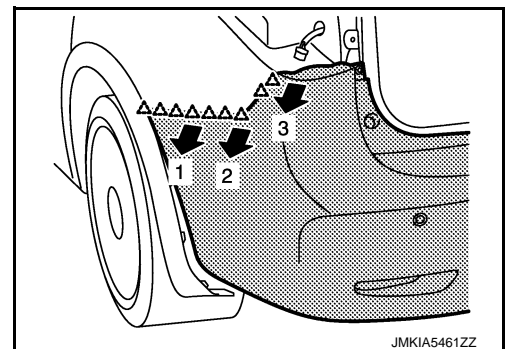

8. Remove bumper fascia assembly.

CAUTION:

When removing bumper fascia assembly, 2 workers are required so as to prevent it from dropping.

9. Remove the following parts after removing rear bumper fascia.
 - Bumper side brackets (LH and RH)
 - Reflex reflector (LH and RH)
 - Bumper stay bracket (LH and RH)
 - Bumper stay (LH and RH)

REAR BUMPER

< REMOVAL AND INSTALLATION >

- Bumper protector (LH and RH)
- Bumper side reinforcement (LH and RH)

10. Remove energy absorber.

INSTALLATION

Note the following item, and then install in the reverse order of removal.

NOTE:

- The following table shows the specified values for checking normal installation status.
- Fitting adjustment cannot be performed.

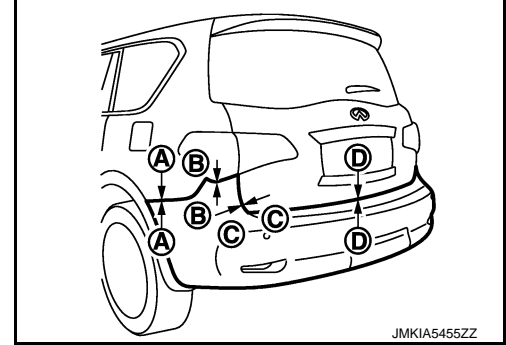

Portion		Clearance	Surface height difference
Bumper fascia assembly – Rear fender	A – A	0.0 – 1.0 mm (0.000 – 0.039 in)	(-0.7) – (+1.3) mm [(-0.028) – (+0.051) in]
Bumper fascia assembly – Rear combination lamp	B – B	0.3 – 3.0 mm (0.012 – 0.118 in)	—
Bumper fascia assembly – Back door	C – C	2.8 – 6.1 mm (0.110 – 0.240 in)	—
Bumper fascia assembly – Back door	D – D	3.8 – 7.8 mm (0.150 – 0.307 in)	—

FRONT GRILLE

< REMOVAL AND INSTALLATION >

FRONT GRILLE

Exploded View

INFOID:000000006367601

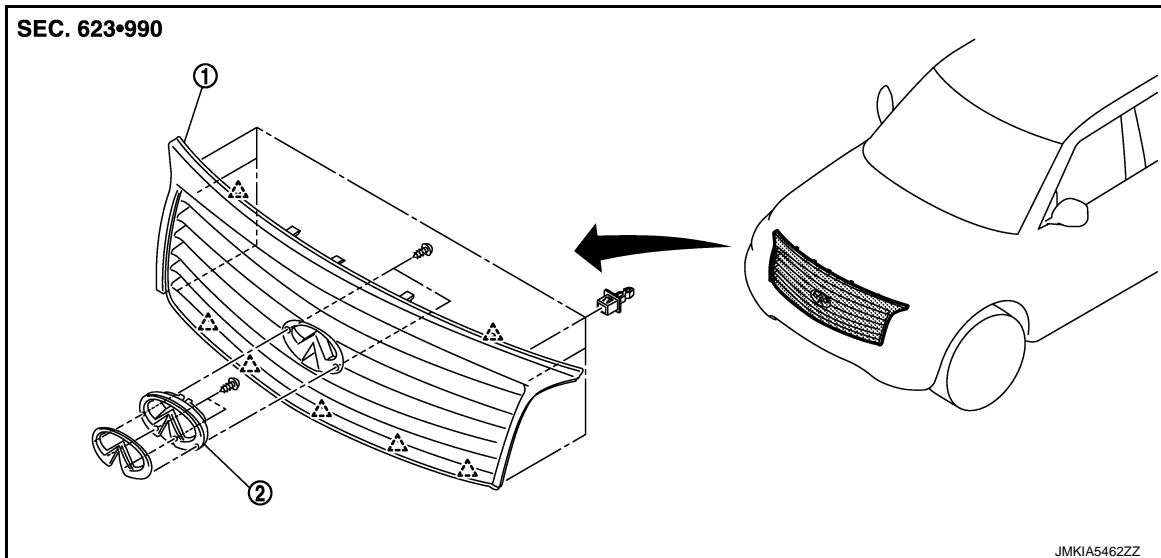

1. Front grille

2. Front emblem

△ : Pawl

Removal and Installation

INFOID:000000006367602

REMOVAL

1. Fully open hood assembly.
2. Apply protective tape (A) on surrounding area of front grille (1).

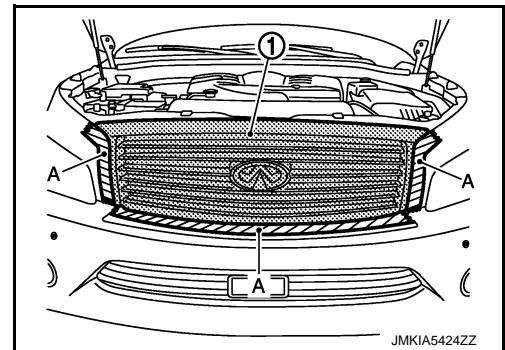

3. Remove front grille upper fixing clips.

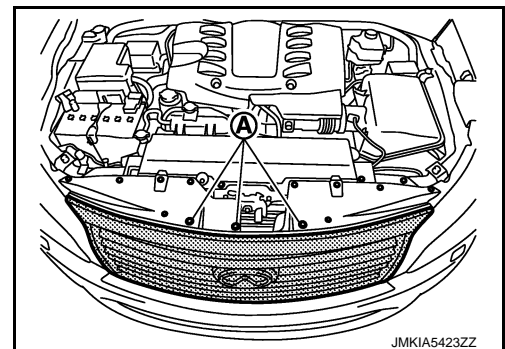

A
B
C
D
E
F
G
H
I
J
EXT
L
M
N
O
P

FRONT GRILLE

< REMOVAL AND INSTALLATION >

4. Pull front grille toward the direction shown in the figure, and then disengage front grille fixing clips.

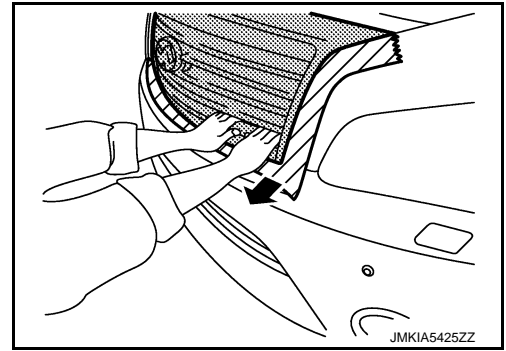

5. Disconnect front camera harness connector, and then remove front grille.
6. Remove emblem after removing front grille.

INSTALLATION

Install in the reverse order of removal.

COWL TOP

< REMOVAL AND INSTALLATION >

COWL TOP

Exploded View

INFOID:000000006367603

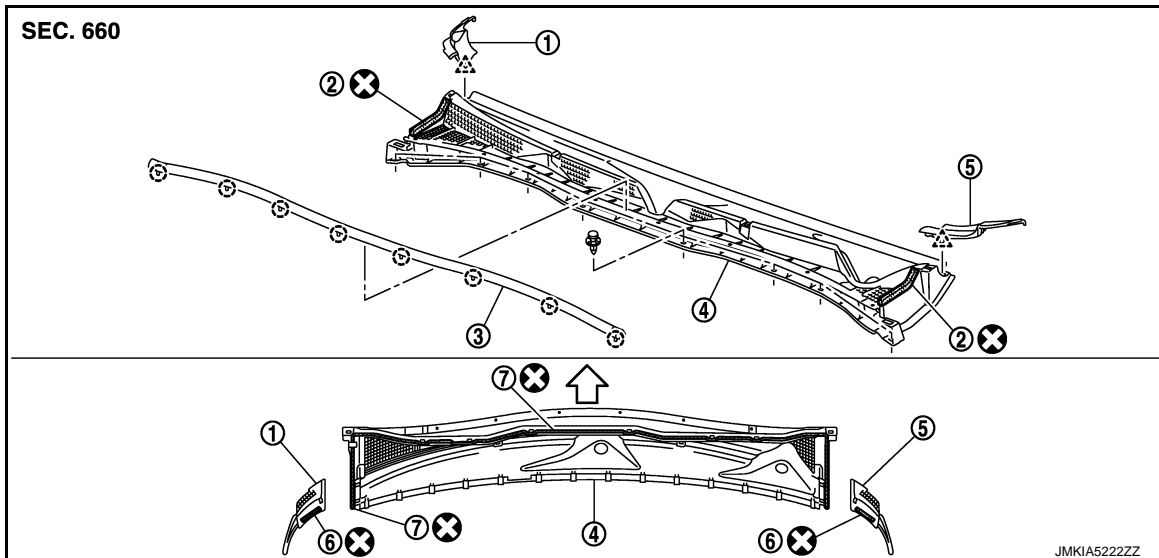

- | | | |
|------------------------------------|-------------------------------------|---|
| 1. Front fender cover RH | 2. EPT seal [t: 15.0 mm (0.591 in)] | 3. Cowl top cover seal |
| 4. Cowl top cover | 5. Front fender cover LH | 6. Double-sided tape [t: 1.2 mm (0.047 in)] |
| 7. EPT seal [t: 3.0 mm (0.118 in)] | | |

○ : Clip

△ : Pawl

← : Vehicle front

Refer to [GI-4. "Components"](#) for symbols in the figure.

Removal and Installation

INFOID:000000006367604

EXT

REMOVAL

1. Fully open hood assembly.
2. Remove front wiper arm (LH and RH). Refer to [WW-66. "Removal and Installation"](#).
3. Remove front fender cover (LH and RH).
4. Disconnect front washer tube connector.
5. Remove cowl top cover fixing clips.
6. Pull forward to release cowl top cover (1) from windshield glass.

CAUTION:

When performing the procedure after removing cowl top cover, cover the lower end of windshield glass with urethane etc.

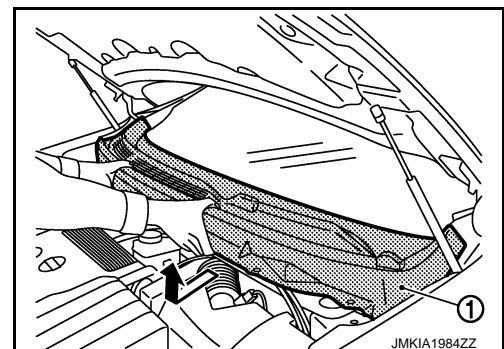

7. Remove the following parts after removing cowl top cover.
 - Cowl top seal
 - Washer nozzle (LH and RH)
 - Washer tube

COWL TOP

< REMOVAL AND INSTALLATION >

- EPT sealer

INSTALLATION

Note the following items and then, install in the reverse order of removal.

CAUTION:

- **When installing cowl top cover, check that blind clips are securely fitted in panel holes on body, and then press them in.**
- **Always replace cowl top cover EPT sealer with a new one when installing old cowl top cover.**
- **After installing, perform adjustment of wiper arms. Refer to [WW-66, "Adjustment"](#).**

FENDER PROTECTOR

< REMOVAL AND INSTALLATION >

FENDER PROTECTOR

FENDER PROTECTOR

FENDER PROTECTOR : Exploded View

INFOID:000000006367605

FENDER PROTECTOR

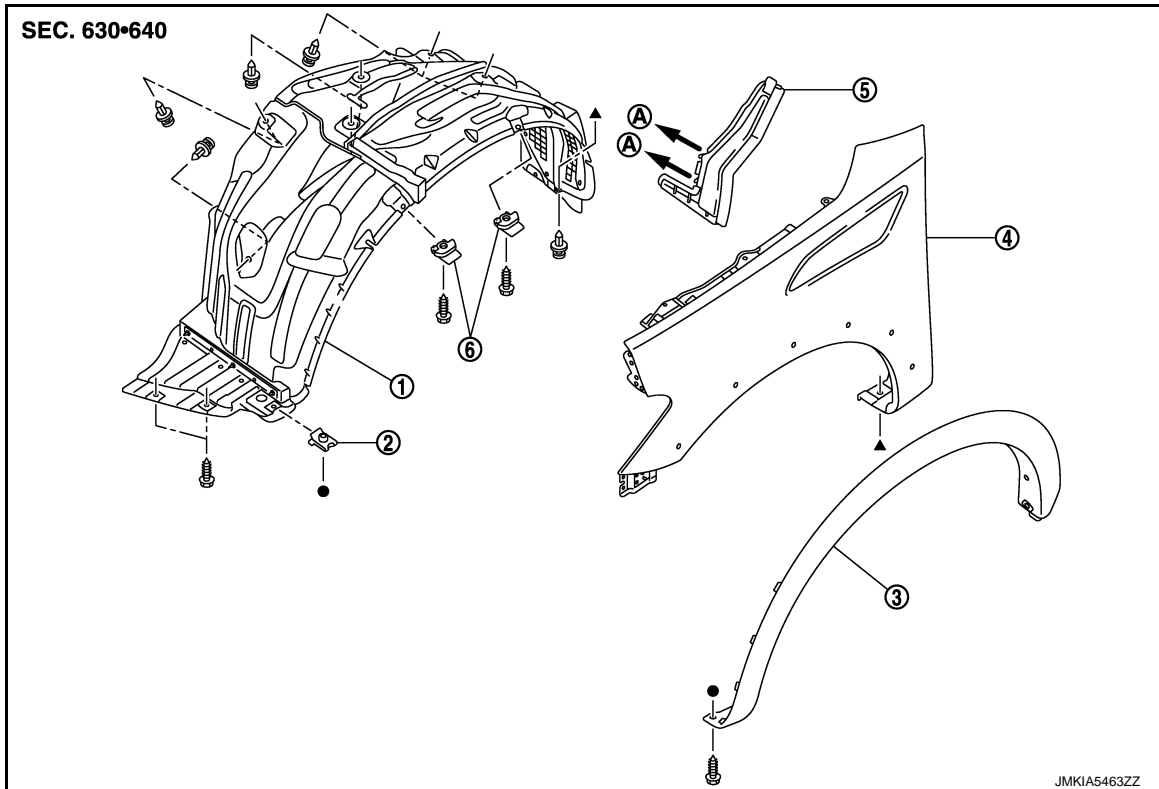

- | | | |
|-----------------------|------------------------|----------------|
| 1. Fender protector | 2. U nut | 3. Over fender |
| 4. Fender | 5. Hoodledge insulator | 6. Fender clip |
| A: To hoodledge panel | | |

FENDER PROTECTOR : Removal and Installation

INFOID:000000006367606

REMOVAL

1. Remove mounting bolts, from front lower.
2. Release front fender protector fixing clips, and then remove front fender protector.
3. Disengage hoodledge insulator fixing pawls, and then remove hoodledge insulator.

INSTALLATION

Install in the reverse order of removal.

REAR WHEEL HOUSE PROTECTOR

FENDER PROTECTOR

< REMOVAL AND INSTALLATION >

REAR WHEEL HOUSE PROTECTOR : Exploded View

INFOID:000000006367607

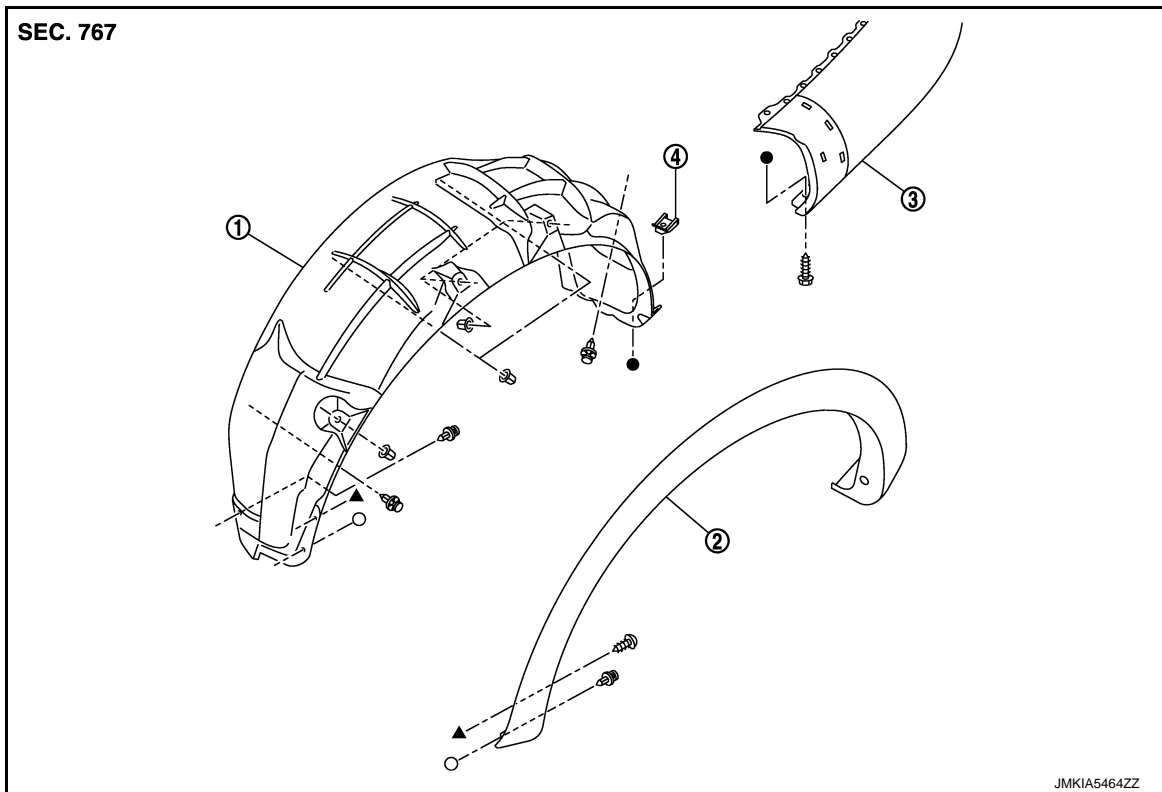

- 1. Rear wheel house protector
- 2. Over fender
- 3. Rear bumper fascia
- 4. Wheel house protector clip

REAR WHEEL HOUSE PROTECTOR : Removal and Installation

INFOID:000000006367608

REMOVAL

1. Remove rear wheel house protector fixing screws.
2. Remove rear wheel house protector fixing clips and then remove rear wheel house protector.

INSTALLATION

Install in the reverse order of removal.

FLOOR SIDE FAIRING

< REMOVAL AND INSTALLATION >

FLOOR SIDE FAIRING

Exploded View

INFOID:000000006367609

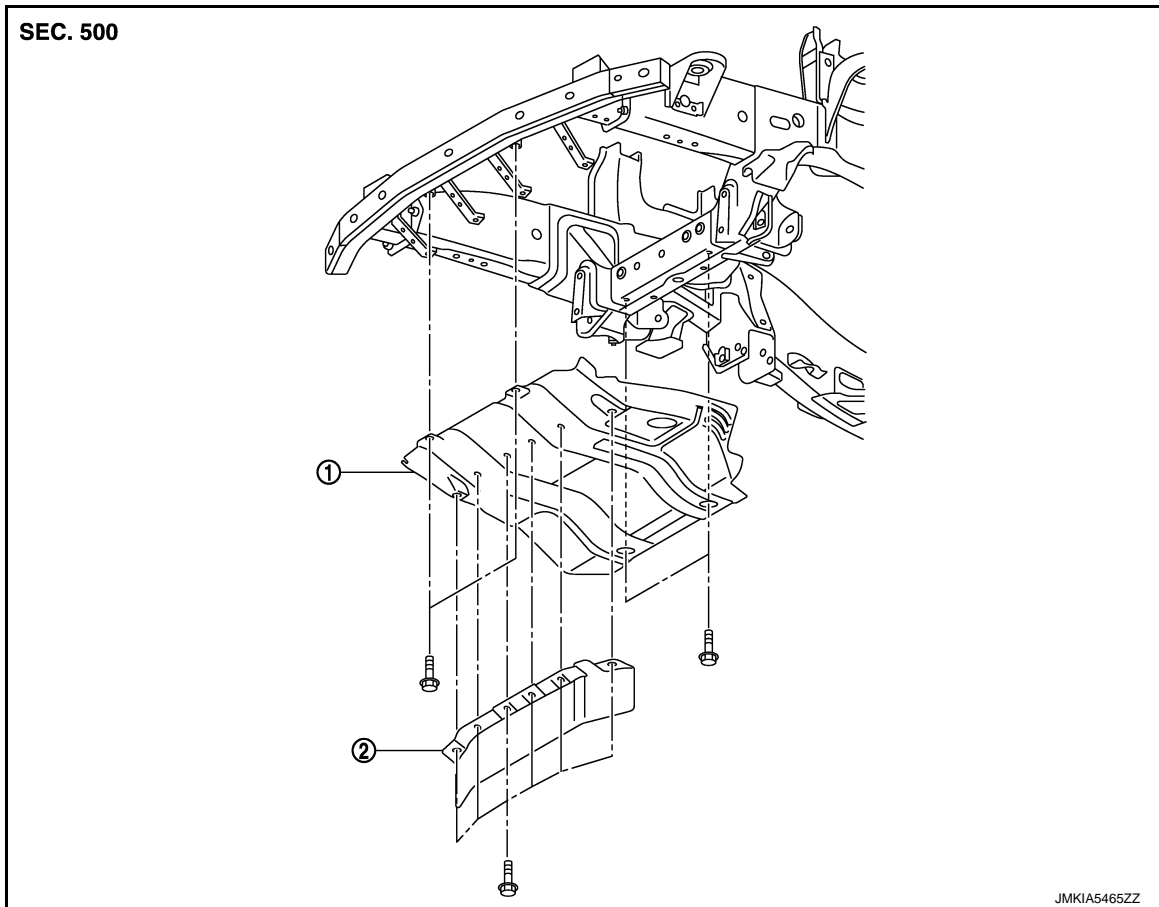

1. Front under cover

2. Front under deflector

A
B
C
D
E
F
G
H
I
J

EXT

Removal and Installation

INFOID:000000006367610

REMOVAL

Front Under Cover

1. Remove front under deflector mounting bolts, and then remove front under deflector.
2. Remove front under cover mounting bolts, and then remove front under cover.

INSTALLATION

Install in the reverse order of removal.

L
M
N
O
P

OVER FENDER

< REMOVAL AND INSTALLATION >

OVER FENDER

Exploded View

INFOID:000000006367611

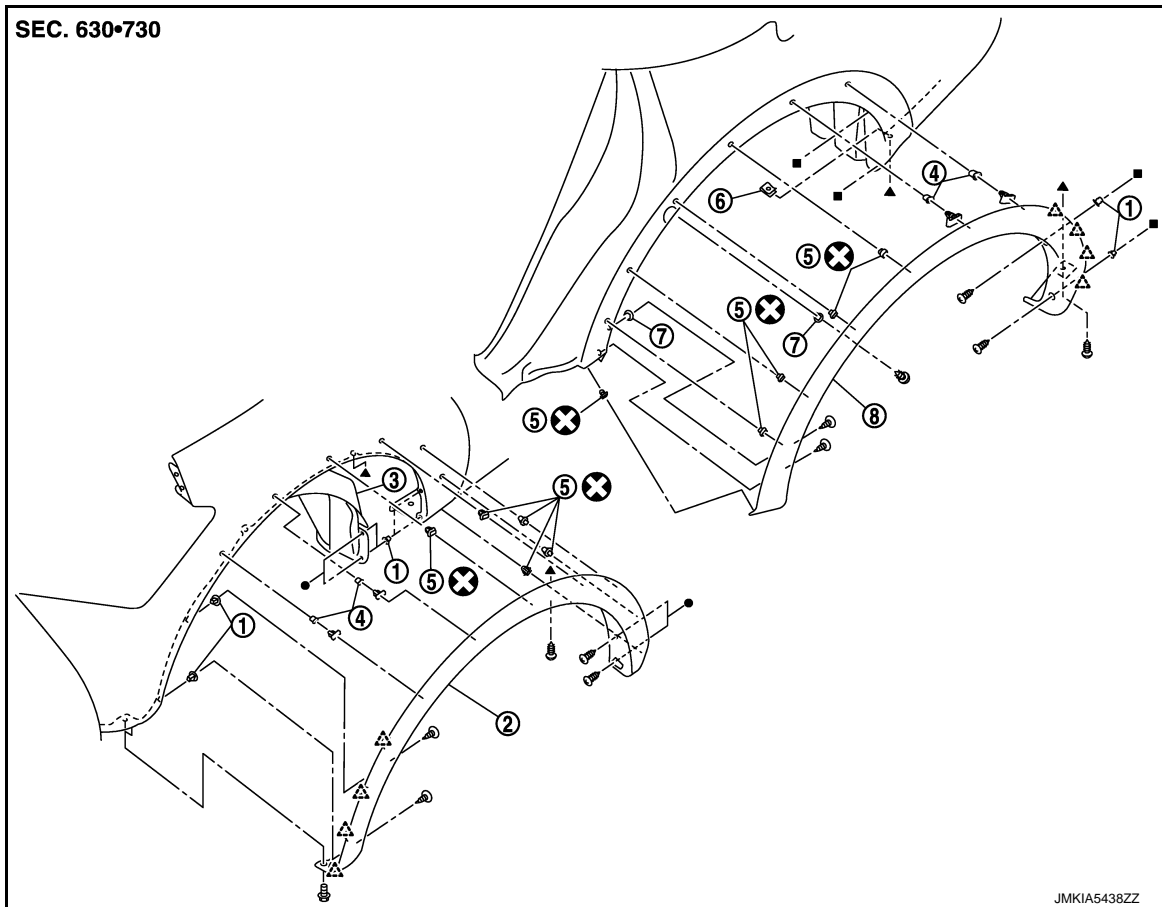

- | | | |
|------------|----------------------|-------------------------|
| 1. Grommet | 2. Front over fender | 3. Front fender proctor |
| 4. Grommet | 5. Clip | 6. U nut |
| 7. Grommet | 8. Rear over fender | |

 : Pawl

Refer to [GI-4, "Components"](#) for symbols in the figure.

Removal and Installation

INFOID:000000006367612

REMOVAL

Front over fender

1. Remove front over fender front side fixing screws and bolts.
2. Remove front fender protector front side. Keep the service area. Refer to [EXT-23, "FENDER PROTECTOR : Removal and Installation"](#).

OVER FENDER

< REMOVAL AND INSTALLATION >

3. Disengage front over fender rear side fixing pawls from behind of front fender, and the pull front over fender front side toward the direction shown in the figure.

 : Pawl

CAUTION:

Never pull the front over fender strongly.

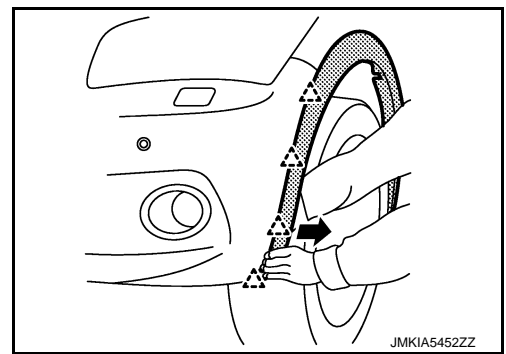

4. Remove front fender protector. Refer to [EXT-23. "FENDER PROTECTOR : Removal and Installation"](#)
5. Remove side step front side fixing clips.
6. Disengage front over fender rear side fixing pawls from behind of fender, and then pull front over fender front side toward the direction shown in the figure.

 : Clip

CAUTION:

Never pull the front over fender strongly.

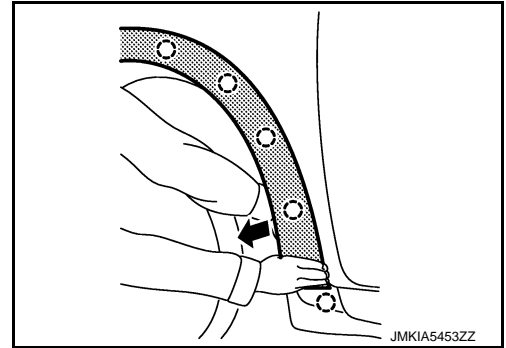

7. Remove front over fender.

Rear over fender

1. Remove rear over fender rear side fixing screws and bolts.
2. Remove rear fender protector rear side. Keep the service area. Refer to [EXT-24. "REAR WHEEL HOUSE PROTECTOR : Removal and Installation"](#).
3. Disengage rear over fender rear side fixing pawls from behind of rear fender, and the pull rear over fender rear side toward the direction shown in the figure.

 : Pawl

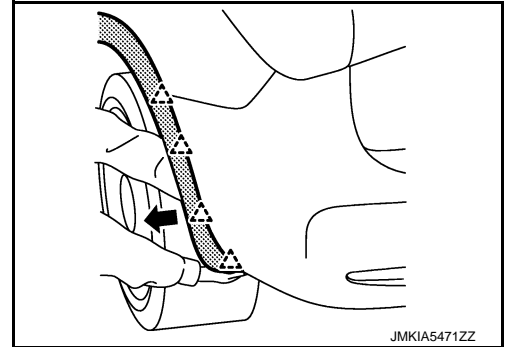

4. Remove rear fender protctor. Refer to [EXT-24. "REAR WHEEL HOUSE PROTECTOR : Removal and Installation"](#).
5. Remove rear over fender front side fixing screws and bolts.
6. Using a remover tool (A), disengage the clips from the rear over fender by starting from the rear.

 : Clip

CAUTION:

- Apply a protective tape (B) on the body to protect the painted surface from damage.
- Disengage the clips slowly and carefully.
- Never pull the front over fender strongly.

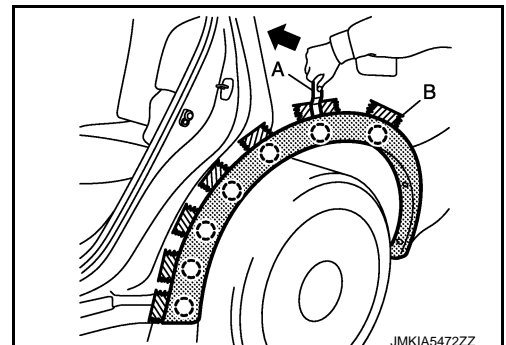

A
B
C
D
E
F
G
H
I
J
EXT
L
M
N
O
P

OVER FENDER

< REMOVAL AND INSTALLATION >

INSTALLATION

Install in the reverse order of removal.

CAUTION:

- When installing, check visually the over fender and the clips, then replace them with new parts if they have been damaged.
- When installing over fender, check that blind clips are securely fitted in panel holes on body, and then press them in.

ROOF RAIL

< REMOVAL AND INSTALLATION >

ROOF RAIL

Exploded View

INFOID:000000006367613

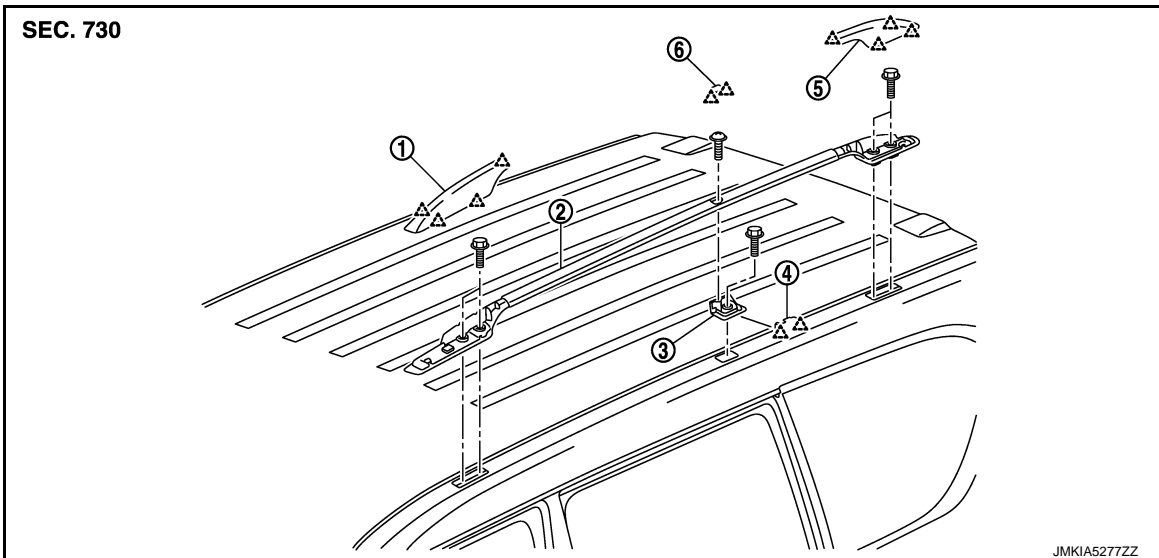

- | | | |
|--------------------------|-------------------------|---------------------------|
| 1. Front roof rail cover | 2. Roof rail assembly | 3. Center leg assembly |
| 4. Center leg cover | 5. Rear roof rail cover | 6. Center roof rail cover |

 : Pawl

Refer to [GI-4. "Components"](#) for symbols in the figure.

Removal and Installation

INFOID:000000006367614

REMOVAL

1. Remove front roof rail cover (1) with remover tool (A).

CAUTION:

Apply protective tape (B) around the roof rail.

 : Pawl

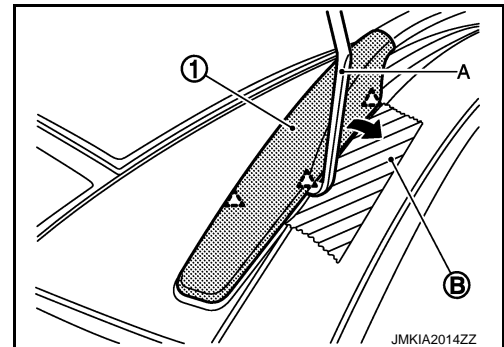

2. Remove center roof rail cover (1) with flat-bladed screwdriver (A).

 : Pawl

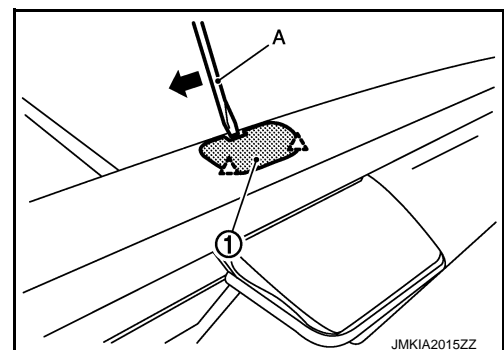

A
B
C
D
E
F
G
H
I
J
L
M
N
O
P

EXT

ROOF RAIL

< REMOVAL AND INSTALLATION >

3. Remove rear roof rail cover (1) with remover tool (A).

CAUTION:

Apply protective tape (B) around the roof rail.

 : Pawl

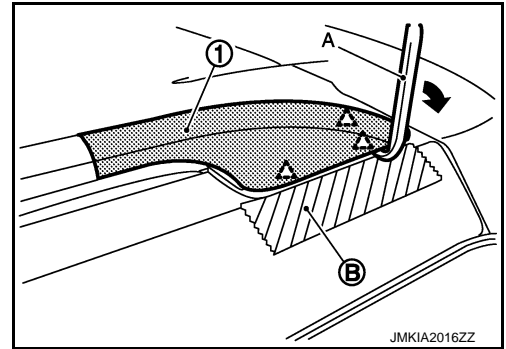

4. Remove roof rail mounting bolts, and then remove roof rail assembly.
5. Pull to the side, disengage pawls and remove center leg cover (1).

 : Pawl

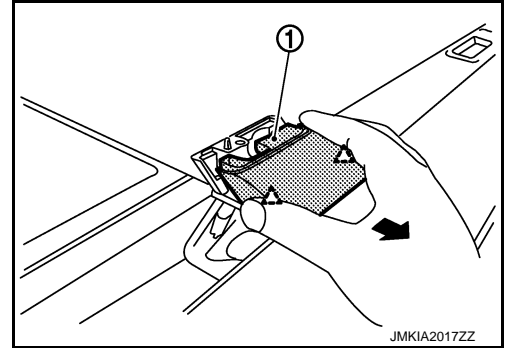

6. Remove roof rail center leg assembly mounting bolt, and then remove roof rail center leg assembly.

INSTALLATION

Install in the reverse order of removal.

ROOF SIDE MOLDING

< REMOVAL AND INSTALLATION >

ROOF SIDE MOLDING

Exploded View

INFOID:000000006367615

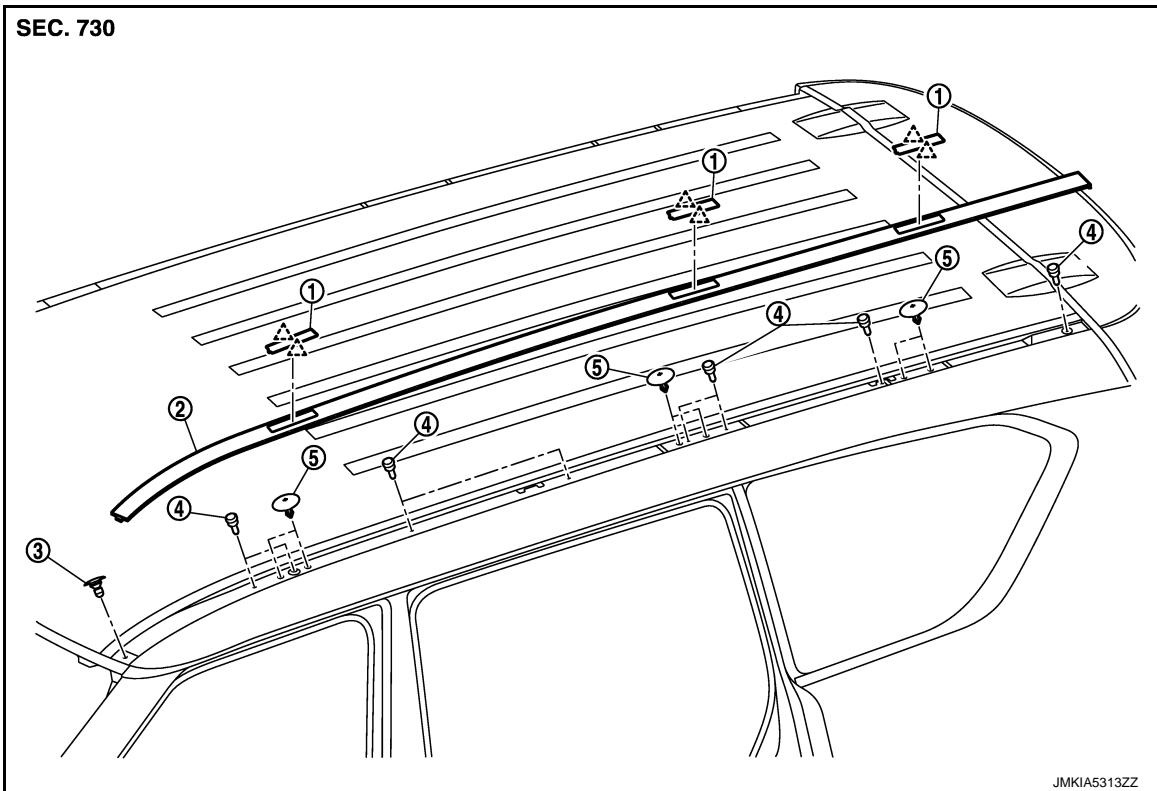

- 1. Roof side molding cap
- 2. Roof side molding
- 3. Grommet
- 4. Roof side molding clip
- 5. Grommet

△ : Pawl

Removal and Installation

INFOID:000000006367616

REMOVAL

1. Remove roof rail assembly and roof rail center leg assembly. Refer to [EXT-29, "Removal and Installation"](#).
2. Disengage roof side molding (1) fixing clips with remover tool (A), and then remove roof side molding.

CAUTION:

Apply protective tape (B) around the roof side molding.

○ : Clip

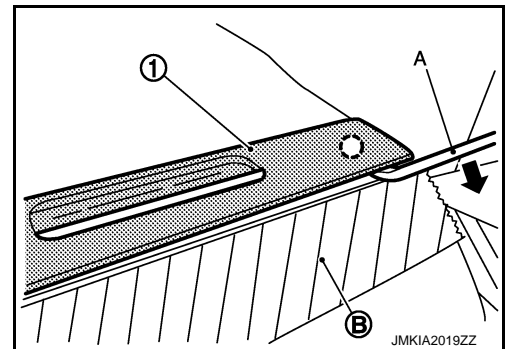

INSTALLATION

Note the following item, and then install in the reverse order of removal.

CAUTION:

To install roof side molding, check if all clips are matched over holes of panel on vehicle, then push it.

DOOR OUTSIDE MOLDING

< REMOVAL AND INSTALLATION >

DOOR OUTSIDE MOLDING

Exploded View

INFOID:000000006367617

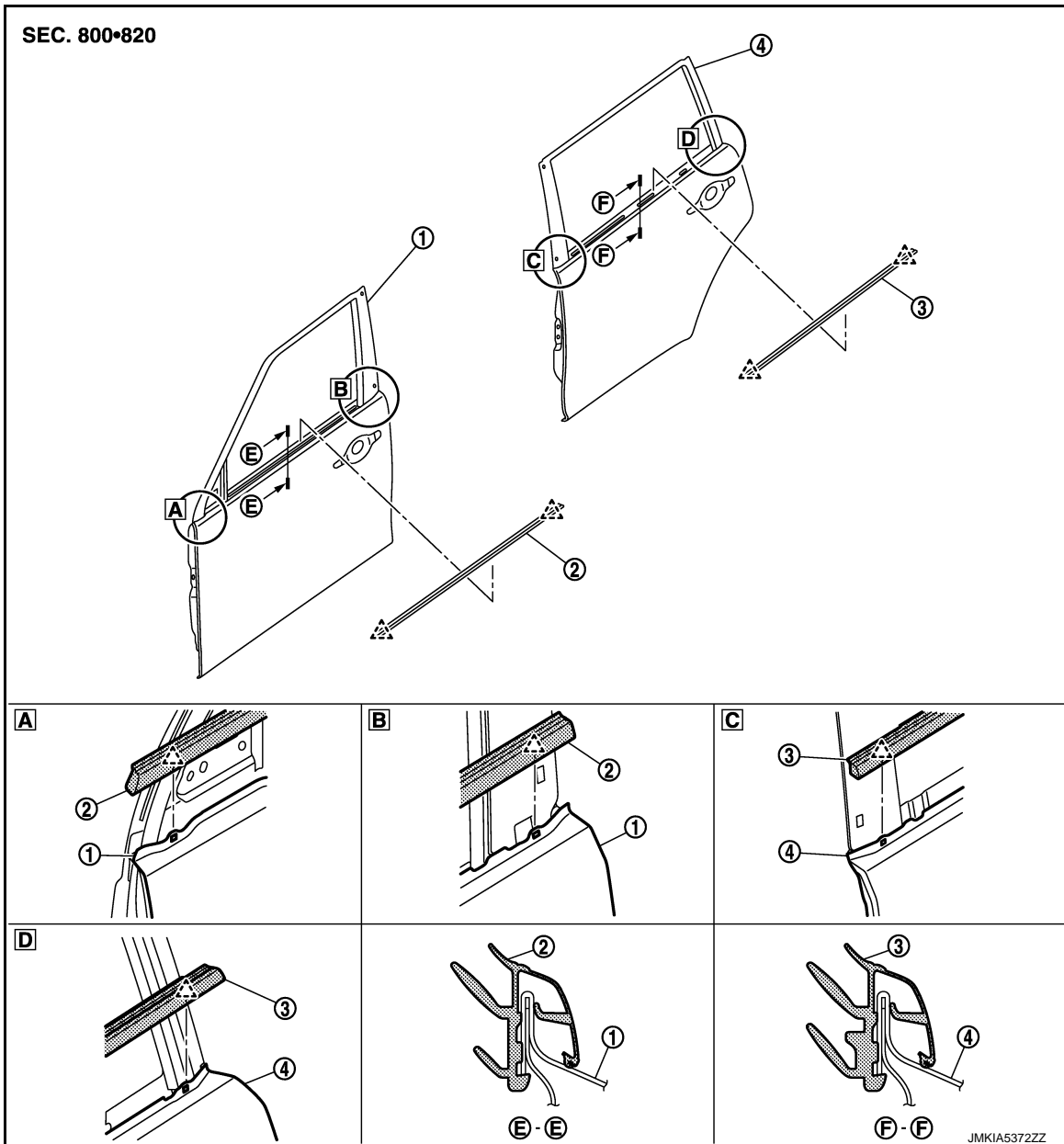

1. Front door panel

2. Front door outside molding

3. Rear door outside molding

4. Rear door panel

 : Pawl

Removal and Installation

INFOID:000000006367618

FRONT DOOR OUTSIDE MOLDING

Removal

1. Fully open door window.

DOOR OUTSIDE MOLDING

< REMOVAL AND INSTALLATION >

2. Twist and pull up to upper side, and then remove front door outside molding (1).

CAUTION:

- Apply protective tape around front door panel.
- Never twist and pull up to door outside molding strongly.

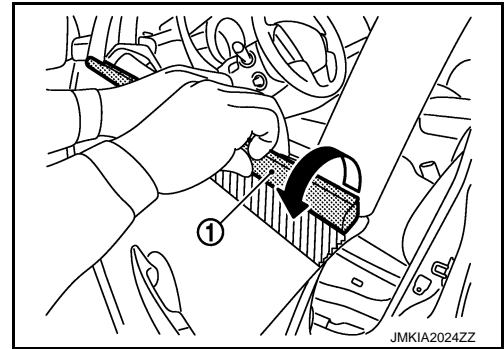

REAR DOOR OUTSIDE MOLDING

1. Fully open door window.
2. Twist and pull up to upper side, and then remove rear door outside molding (1).

CAUTION:

- Apply protective tape around rear door panel.
- Never twist and pull up to door outside molding strongly.

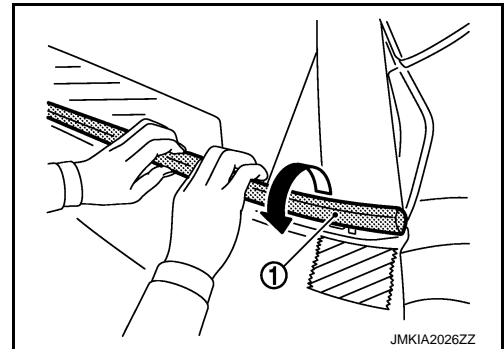

Installation

Install in the reverse order of removal.

A
B
C
D
E
F
G
H
I
J
L
M
N
O
P

EXT

DOOR PARTING SEAL

< REMOVAL AND INSTALLATION >

DOOR PARTING SEAL

Exploded View

INFOID:000000006367619

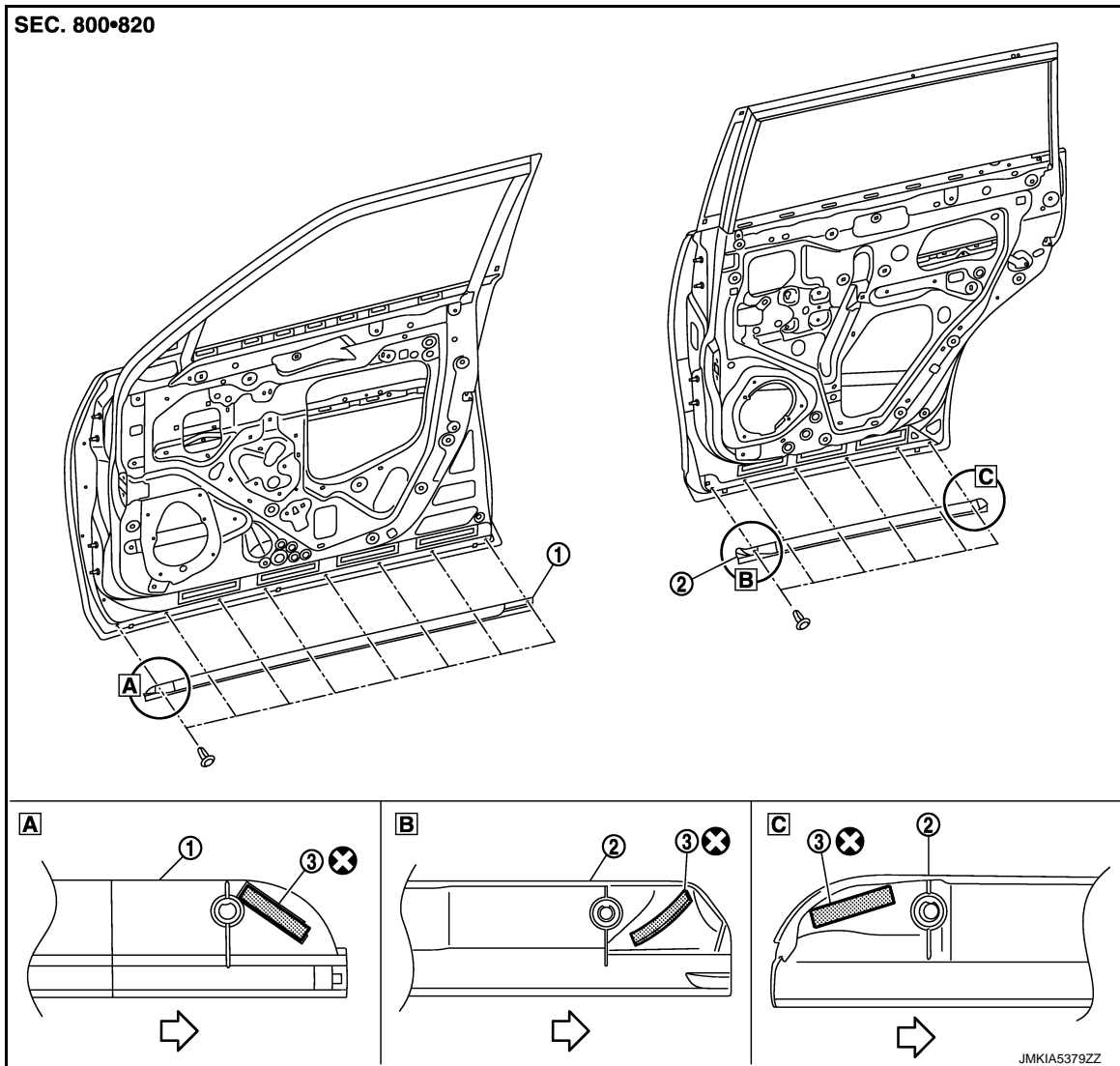

1. Front door parting seal

2. Rear door parting seal

3. Double sided tape
[0.8 mm (0.031) in]

← : Vehicle front

Refer to [GI-4. "Components"](#) for symbols in the figure.

Removal and Installation

INFOID:000000006367620

REMOVAL

1. Fully open door.
2. Disengage the door parting seal fixing clips with a remover tool, and then remove door parting seal.

CAUTION:

- Disengage the clips slowly and carefully.
- Never pull the door parting seal strongly.

INSTALLATION

Note the following items, and then install in the reverse order of removal.

CAUTION:

DOOR PARTING SEAL

< REMOVAL AND INSTALLATION >

- When installing, check visually the clips, then replace them with new parts if they have been damaged.
- When installing door parting seal, check that blind clips are securely fitted in panel holes on body, and then press them in.
- Always replace double-sided tape with a new one, if door parting seal.

A

B

C

D

E

F

G

H

I

J

EXT

L

M

N

O

P

SILL MOLDING

< REMOVAL AND INSTALLATION >

SILL MOLDING

Exploded View

INFOID:000000006367621

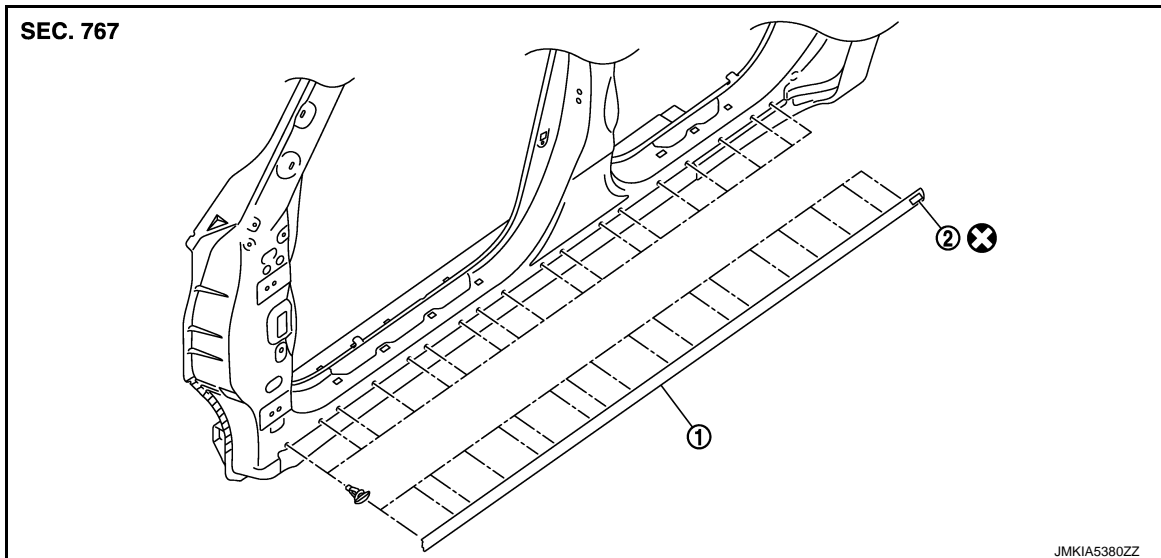

1. Sill molding
2. Double-sided tape
[t: 1.2 mm (0.047) in]

Refer to [GI-4. "Components"](#) for symbols in the figure.

Removal and Installation

INFOID:000000006367622

REMOVAL

1. Fully open front and rear door.
2. Disengage sill molding (1) fixing clips with a remover tool (A), and then remove sill molding.

CAUTION:

- Disengage the clips slowly and carefully.
- Never pull the sill molding strongly.

 : Clip

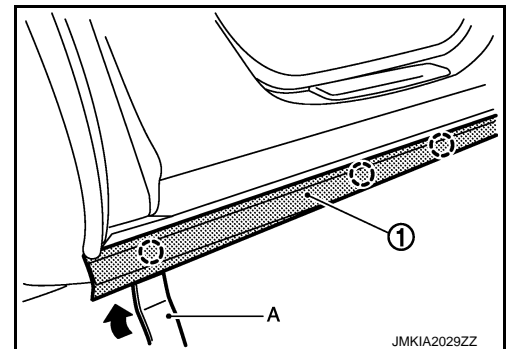

INSTALLATION

Note the following items, and then install in the reverse order of removal.

CAUTION:

- When installing, check visually the sill molding and the clips, then replace them with new parts if they have been damaged.
- When installing the sill molding, check that blind clips are securely fitted in panel holes on body, and then press them in.

DOOR SASH COVER

< REMOVAL AND INSTALLATION >

DOOR SASH COVER

Exploded View

INFOID:000000006367623

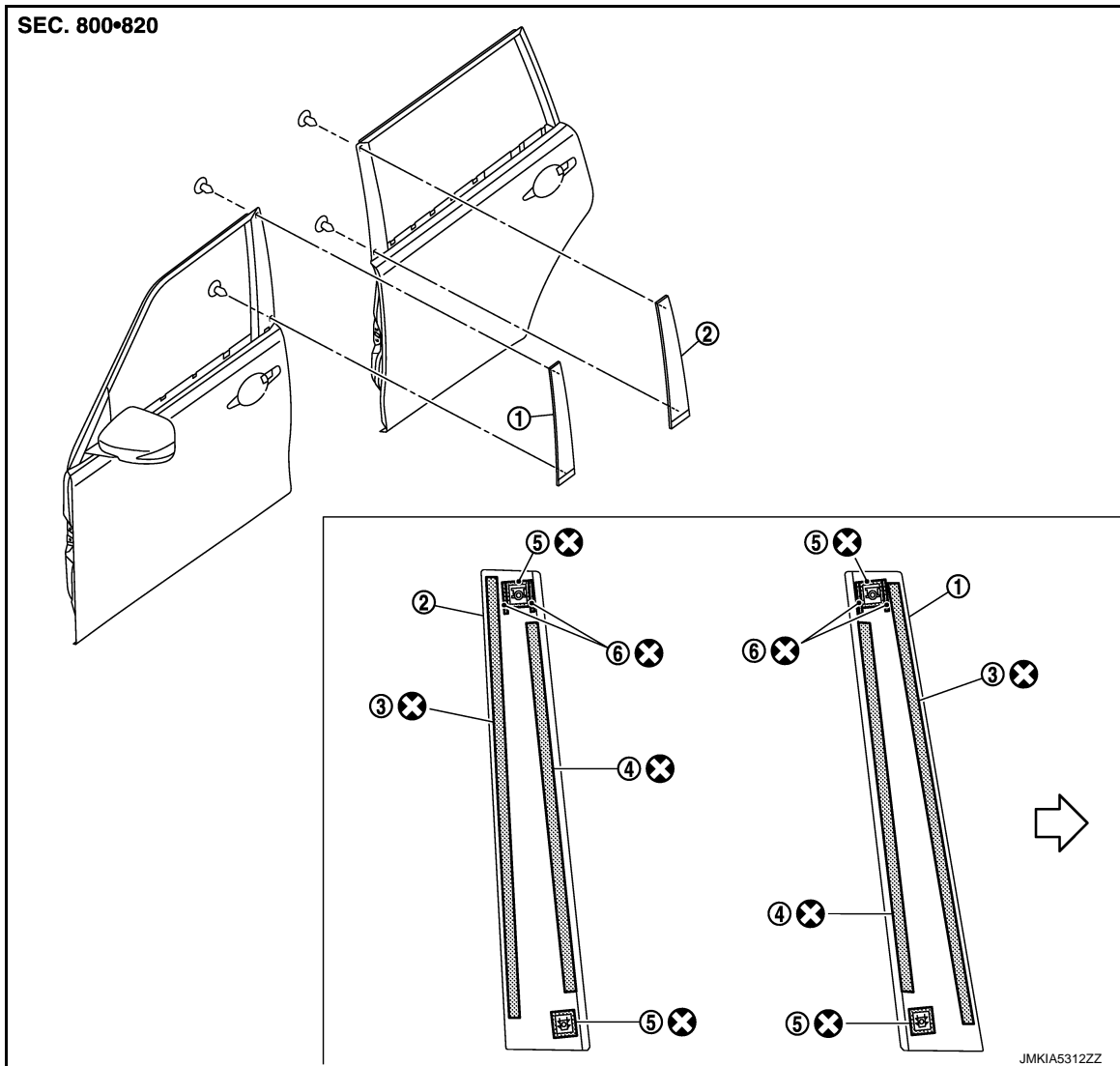

- | | | |
|---|---|---|
| 1. Front door sash cover | 2. Rear door sash cover | 3. Double sided tape
[1.2 mm (0.047) in] |
| 4. Double sided tape
[2.0 mm (0.079) in] | 5. Double sided tape
[1.6 mm (0.063) in] | 6. EPT seal
[1.6 mm (0.063) in] |

⊖ : Clip

← : Vehicle front

Refer to [GI-4, "Components"](#) for symbols in the figure.

Removal and Installation

INFOID:000000006367624

FRONT DOOR SASH COVER

Removal

1. Remove front door sash cover fixing clips.

A
B
C
D
E
F
G
H
I
J
EXT
L
M
N
O
P

DOOR SASH COVER

< REMOVAL AND INSTALLATION >

2. Insert a remover tool (A) between front door sash cover (1) and door panel, cut double-sided tape using a cutter (B) while lifting front door sash cover, and remove front door sash cover.

CAUTION:

- Use a remover tool which is made of a material that does not damage door panel.
- Never lift front door sash cover with excessive force.

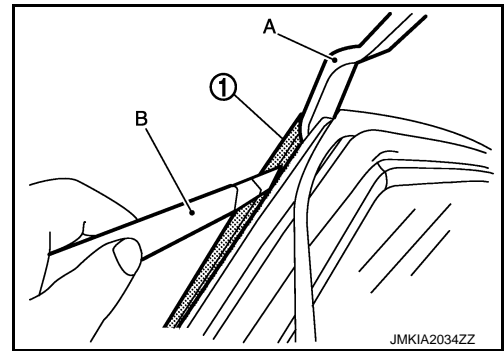

Installation

Note the following items, and then install in the reverse order of removal.

CAUTION:

- When installing, slide and install front door sash cover (2) from door rear side, so that front door outside molding (1) is not deformed.

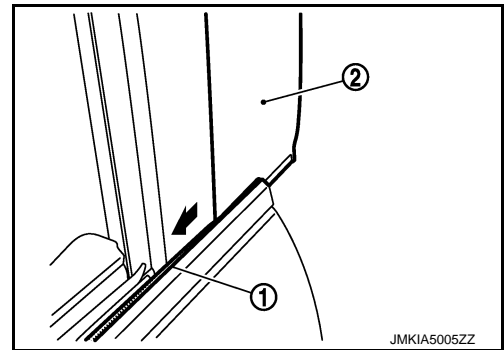

- Replace double-sided tape on back of front door sash cover with a new double-sided adhesive tape if front door sash cover is reused.
- Replace EPT sealer of front door sash cover with a new EPT sealer if front door sash cover is reused.
- Remove double-sided adhesive tape remaining on body and back of front door sash cover using double-sided adhesive tape remover when removing front door sash molding.
- Install after cleaning adhesive parts of door side and back of front door sash cover.
- To secure contact, do not wash vehicle within 24 hours after installation.

REAR DOOR SASH COVER

Removal

1. Remove rear door sash cover fixing clips.
2. Insert a remover tool (A) between rear door sash cover (1) and door panel, cut double-sided tape using a cutter (B) while lifting rear door sash cover, and remove rear door sash cover.

CAUTION:

- Never use an item as a remover tool that could damage door panel.
- Never lift rear door sash cover with excessive force.

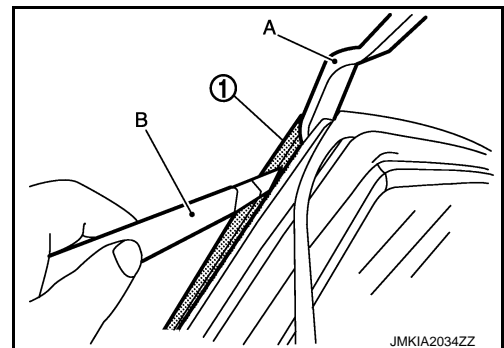

Installation

Note the following items, and install in the reverse order of removal.

CAUTION:

DOOR SASH COVER

< REMOVAL AND INSTALLATION >

- When installing, slide and install rear door sash cover (2) from door front, so that rear door outside molding (1) is not deformed.

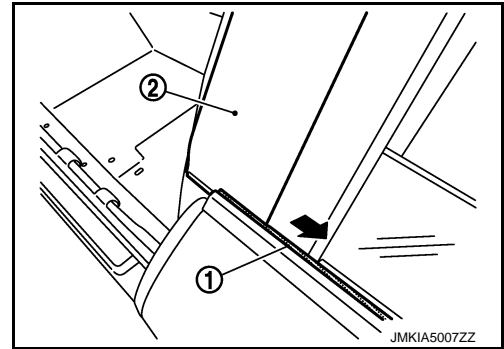

- Replace double-sided adhesive tape on back of rear door sash cover with a new double-sided adhesive tape if rear door sash cover is reused.
- Replace EPT sealer of rear door sash cover with a new EPT sealer if rear door sash cover is reused.
- Remove double-sided adhesive tape remaining on body and back of rear door sash cover using double-sided adhesive tape remover when removing rear door sash cover.
- Install after cleaning adhesive parts of door side and back of rear door sash cover.
- To secure contact, do not wash vehicle within 24 hours after installation.

A
B
C
D
E
F
G
H
I
J
L
M
N
O
P

EXT

FRONT PILLAR FINISHER

< REMOVAL AND INSTALLATION >

FRONT PILLAR FINISHER

Exploded View

INFOID:000000006367625

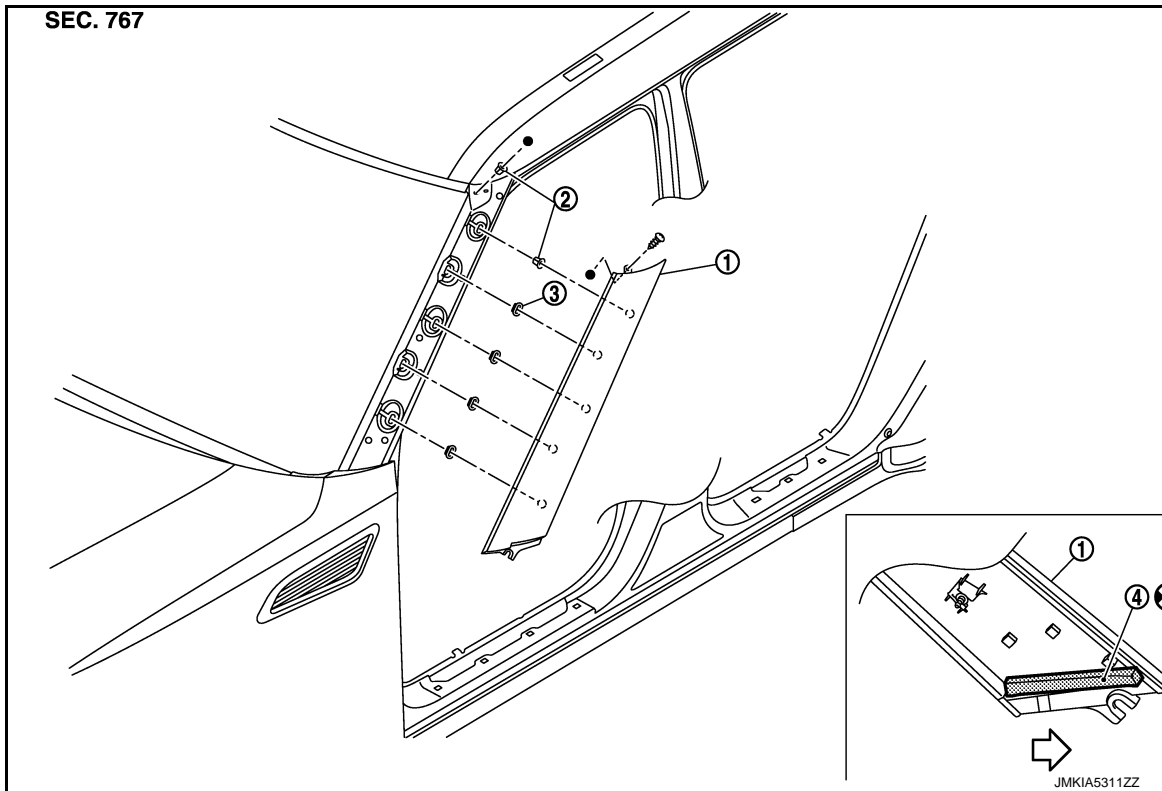

1. Front pillar finisher 2. Grommet 3. Grommet
4. EPT sealer [t: 12.0 mm (0.472 in)]

← : Vehicle front

Refer to [GI-4, "Components"](#) for symbols in the figure.

Removal and Installation

INFOID:000000006367626

REMOVAL

1. Remove roof drip molding. Refer to [EXT-43, "Removal and Installation"](#).
2. Remove front pillar finisher fixing screw.
3. Disengage clips with remover tool, and then remove front pillar finisher.

INSTALLATION

Note the following items, and then install in the reverse order of removal.

CAUTION:

- **Visually check the clips for deformation and damage during installation. Replace with new ones if necessary.**
- **When installing front pillar finisher, check that clips are securely fitted in body panel holes, and press them in.**

REAR SPOILER

< REMOVAL AND INSTALLATION >

REAR SPOILER

Exploded View

INFOID:000000006367627

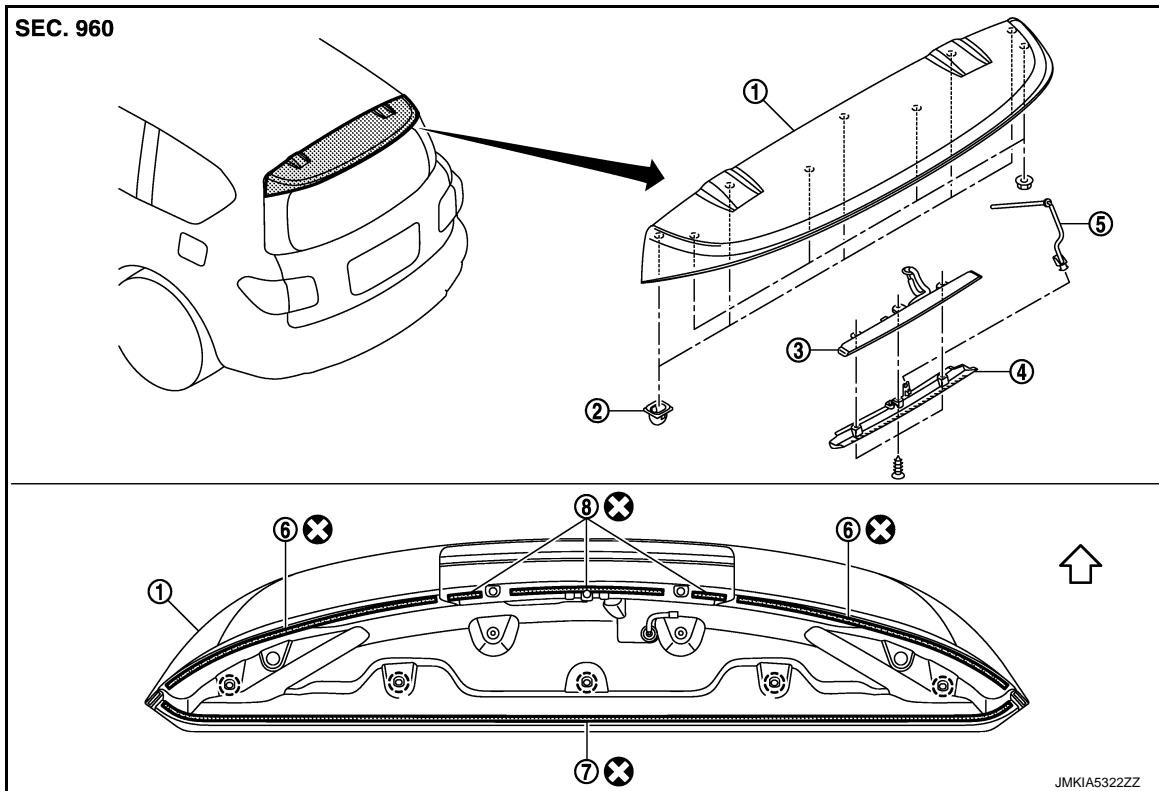

- | | | |
|---|--------------------------------------|--------------------------------------|
| 1. Rear spoiler assembly | 2. Grommet | 3. High-mounted stop lamp |
| 4. High-mounted stop lamp cover | 5. Washer nozzle | 6. EPT sealer [t: 5.0 mm (0.197 in)] |
| 7. Double-sided tape [t: 1.6 mm (0.063 in)] | 8. EPT sealer [t: 4.0 mm (0.157 in)] | |

⊖ : Clip

← : Vehicle front

Refer to [GI-4. "Components"](#) for symbols in the figure.

Removal and Installation

INFOID:000000006367628

REMOVAL

1. Remove back door trim. Refer to [INT-39. "Removal and Installation"](#).
2. Remove rear spoiler mounting nuts.
3. Cut rear spoiler fixing double-sided tape with cutter knife.
4. Disengage rear spoiler fixing clips with remover tool (A), and then remove rear spoiler.

CAUTION:

Apply a protective tape (B) on body panel and rear spoiler to protect the painted surface from damage.

⊖ : Clip

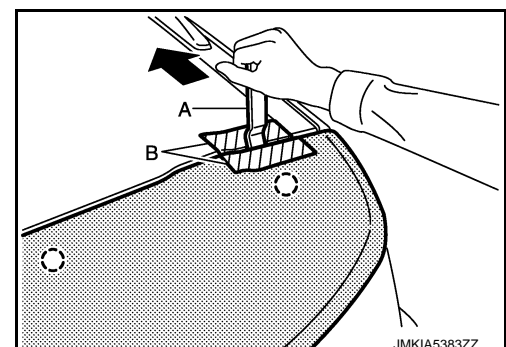

REAR SPOILER

< REMOVAL AND INSTALLATION >

5. Remove following parts after removing rear spoiler.
 - High-mounted stop lamp
 - Grommets
 - Washer nozzle

INSTALLATION

Note the following items, and then install in the reverse order of removal.

CAUTION:

- **Be careful no to damage the back door.**
- **Always replace double-sided tape with a new one, if rear spoiler is reused.**
- **Remove double-sided tape remaining on back door panel and back of rear spoiler with a double-sided tape remover, after removing rear spoiler.**
- **When installing, visually check the rear spoiler and the clips, then replace them with new parts if they are damaged.**
- **When installing rear spoiler, check that clips and bolts are securely fitted in back door panel holes, and then press them in.**
- **Never wash the vehicle within 24 hours after installing so as to keep adhesive.**

DRIP MOLDING

< REMOVAL AND INSTALLATION >

DRIP MOLDING

Exploded View

INFOID:000000006367629

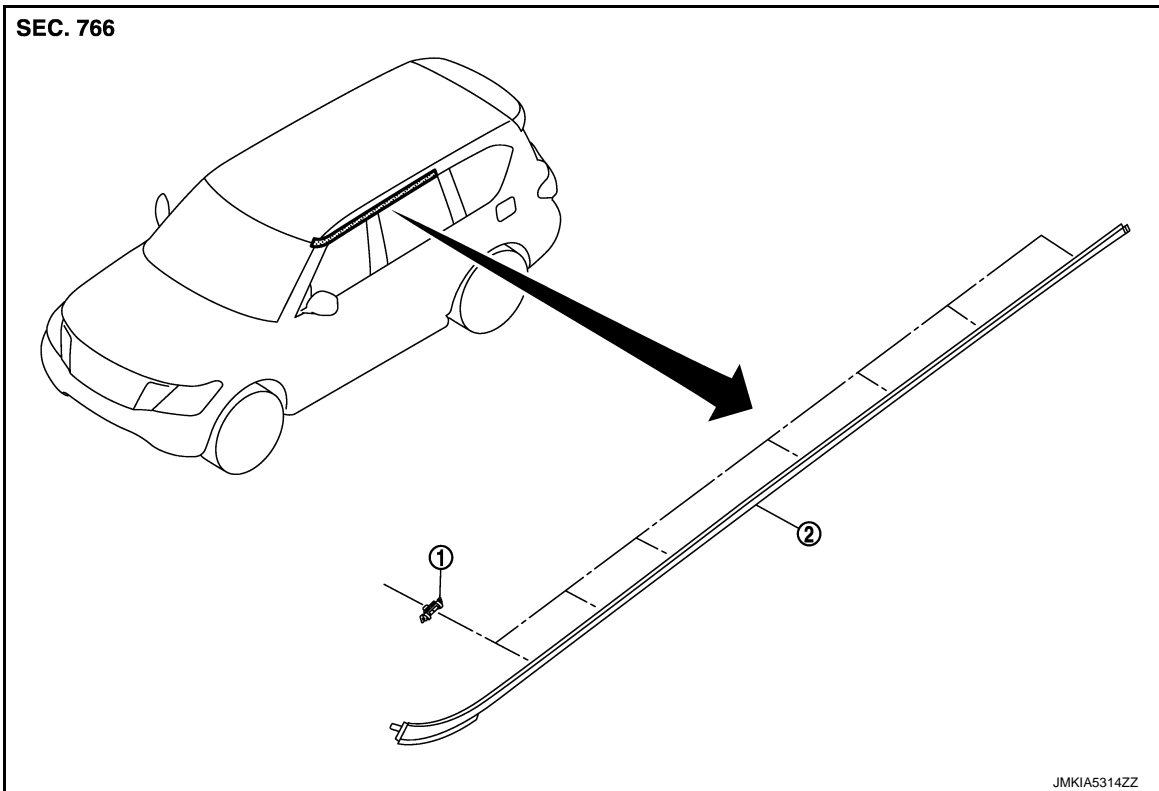

1. Drip molding clip

2. Drip molding

Removal and Installation

INFOID:000000006367630

REMOVAL

Remove drip molding fixing clips from rear end to front end using remover tool (A).

CAUTION:

Apply protective tape (B) on body panel to protect the painted damage from damage.

○ : Clip

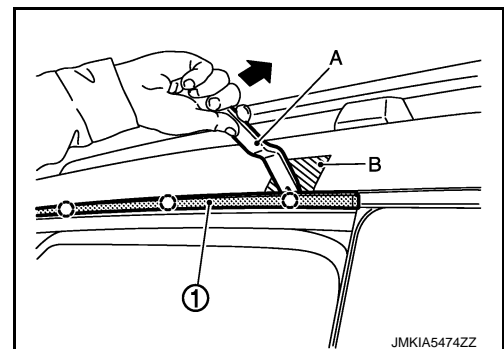

INSTALLATION

Note the following items, and then install in the reverse order of removal.

CAUTION:

When installing, check visually the drip molding and clips, then replace them with new parts if they are damaged.

A
B
C
D
E
F
G
H
I
J
EXT
L
M
N
O
P

BACK DOOR FINISHER

< REMOVAL AND INSTALLATION >

BACK DOOR FINISHER

Exploded View

INFOID:000000006367631

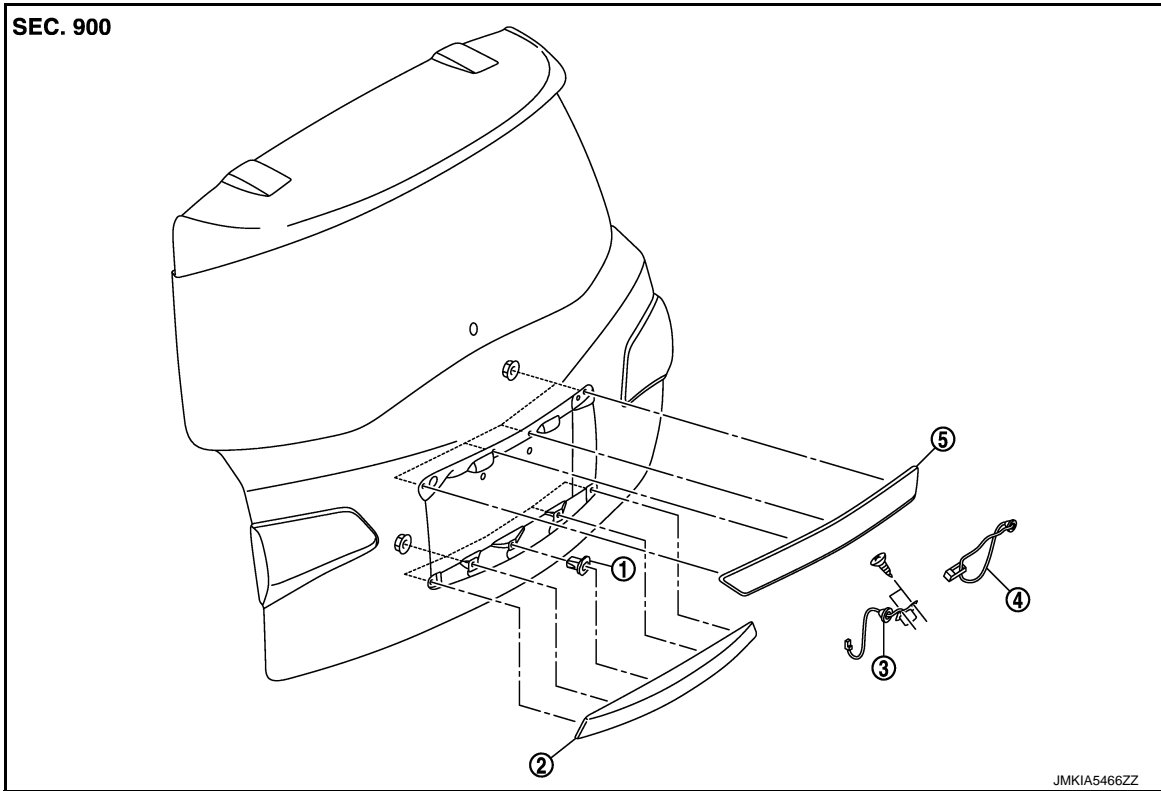

- | | | |
|------------------------------------|------------------------------------|---------------------|
| 1. Grommet | 2. Back door finisher center lower | 3. Rear view camera |
| 4. Back door opener request switch | 5. Back door finisher center upper | |

Removal and Installation

INFOID:000000006367632

REMOVAL

Back Door Finisher Center Upper

1. Remove back door trim. Refer to [INT-39. "Removal and Installation"](#).
2. Disconnect rear view camera and back door opener switch harness connectors.
3. Remove back door finisher center upper mounting nuts.
4. Disengage fixing clips, and then remove back door finisher center upper.
5. Remove following parts after removing back door finisher center upper mounting nuts.
 - Rear view camera
 - Back door opener switch
 - License lamp

Back Door Finisher Center Lower

1. Remove back door trim. Refer to [INT-39. "Removal and Installation"](#).
2. Remove back door finisher center lower mounting nuts.
3. Disengage fixing clips, and then remove back door finisher center lower.

INSTALLATION

Install in the reverse order of removal.

SIDE STEP

< REMOVAL AND INSTALLATION >

SIDE STEP

Exploded View

INFOID:000000006367633

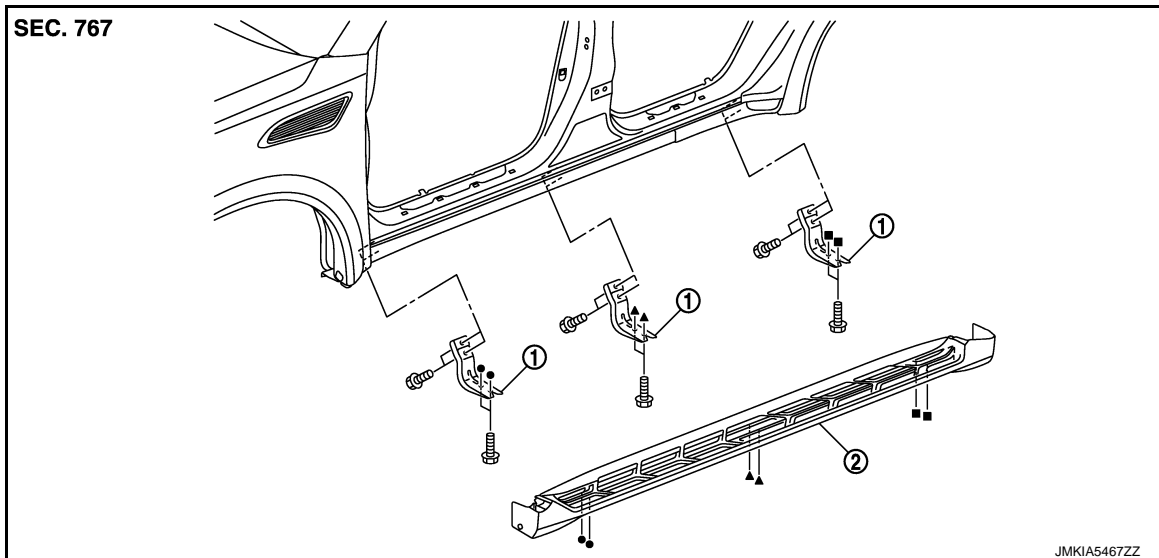

1. Side step bracket

2. Side step

Removal and Installation

INFOID:000000006367634

REMOVAL

1. Remove side step mounting bolts, and then remove side step.
2. Remove side step bracket mounting bolts, and then remove side step brackets.

INSTALLATION

Install in the reverse order of removal.

A
B
C
D
E
F
G
H
I
J
L
M
N
O
P

EXT