

SECTION **FAX**
FRONT AXLE

A
B
C

FAX

CONTENTS

E

2WD	PRECAUTION 3	PRECAUTION 11	F
	PRECAUTIONS 3	PRECAUTIONS 11	G
	Precaution for Supplemental Restraint System (SRS) "AIR BAG" and "SEAT BELT PRE-TENSIONER" 3	Precaution for Supplemental Restraint System (SRS) "AIR BAG" and "SEAT BELT PRE-TENSIONER" 11	H
	Precaution Necessary for Steering Wheel Rotation after Battery Disconnect 3	Precaution Necessary for Steering Wheel Rotation after Battery Disconnect 11	
	PREPARATION 5	PREPARATION 13	I
	PREPARATION 5	Special Service Tools 13	J
	Commercial Service Tools 5	Commercial Service Tools 13	
	SYMPTOM DIAGNOSIS 6	SYMPTOM DIAGNOSIS 15	K
	NOISE, VIBRATION AND HARSHNESS (NVH) TROUBLESHOOTING 6	NOISE, VIBRATION AND HARSHNESS (NVH) TROUBLESHOOTING 15	L
	NVH Troubleshooting Chart 6	NVH Troubleshooting Chart 15	
	PERIODIC MAINTENANCE 7	PERIODIC MAINTENANCE 16	M
	FRONT WHEEL HUB AND KNUCKLE 7	FRONT WHEEL HUB AND KNUCKLE 16	N
	Inspection 7	Inspection 16	
	REMOVAL AND INSTALLATION 8	FRONT DRIVE SHAFT 17	O
	FRONT WHEEL HUB AND KNUCKLE 8	Inspection 17	P
	Exploded View 8	REMOVAL AND INSTALLATION 18	
	Removal and Installation 8	FRONT WHEEL HUB AND KNUCKLE 18	
	Inspection 9	Exploded View 18	
	SERVICE DATA AND SPECIFICATIONS (SDS) 10	Removal and Installation 18	
	SERVICE DATA AND SPECIFICATIONS (SDS) 10	Inspection 20	
	Wheel Hub and Bearing Assembly 10	FRONT DRIVE SHAFT BOOT 21	
4WD		Exploded View 21	
		Removal and Installation 21	
		Inspection 21	
		FRONT DRIVE SHAFT 22	

Exploded View	22
Removal and Installation	22
WHEEL SIDE	23
WHEEL SIDE : Disassembly and Assembly	23
FINAL DRIVE SIDE	26
FINAL DRIVE SIDE : Disassembly and Assembly...	26
Inspection	28

SERVICE DATA AND SPECIFICATIONS (SDS) 29

SERVICE DATA AND SPECIFICATIONS (SDS) 29

Wheel Hub and Bearing Assembly	29
Drive Shaft	29

PRECAUTION

PRECAUTIONS

Precaution for Supplemental Restraint System (SRS) "AIR BAG" and "SEAT BELT PRE-TENSIONER"

INFOID:000000006271838

The Supplemental Restraint System such as "AIR BAG" and "SEAT BELT PRE-TENSIONER", used along with a front seat belt, helps to reduce the risk or severity of injury to the driver and front passenger for certain types of collision. This system includes seat belt switch inputs and dual stage front air bag modules. The SRS system uses the seat belt switches to determine the front air bag deployment, and may only deploy one front air bag, depending on the severity of a collision and whether the front occupants are belted or unbelted. Information necessary to service the system safely is included in the "SRS AIR BAG" and "SEAT BELT" of this Service Manual.

WARNING:

- To avoid rendering the SRS inoperative, which could increase the risk of personal injury or death in the event of a collision that would result in air bag inflation, all maintenance must be performed by an authorized NISSAN/INFINITI dealer.
- Improper maintenance, including incorrect removal and installation of the SRS, can lead to personal injury caused by unintentional activation of the system. For removal of Spiral Cable and Air Bag Module, see the "SRS AIR BAG".
- Do not use electrical test equipment on any circuit related to the SRS unless instructed to in this Service Manual. SRS wiring harnesses can be identified by yellow and/or orange harnesses or harness connectors.

PRECAUTIONS WHEN USING POWER TOOLS (AIR OR ELECTRIC) AND HAMMERS

WARNING:

- When working near the Air Bag Diagnosis Sensor Unit or other Air Bag System sensors with the ignition ON or engine running, DO NOT use air or electric power tools or strike near the sensor(s) with a hammer. Heavy vibration could activate the sensor(s) and deploy the air bag(s), possibly causing serious injury.
- When using air or electric power tools or hammers, always switch the ignition OFF, disconnect the battery, and wait at least 3 minutes before performing any service.

Precaution Necessary for Steering Wheel Rotation after Battery Disconnect

INFOID:000000006271942

NOTE:

- Before removing and installing any control units, first turn the push-button ignition switch to the LOCK position, then disconnect both battery cables.
- After finishing work, confirm that all control unit connectors are connected properly, then re-connect both battery cables.
- Always use CONSULT-III to perform self-diagnosis as a part of each function inspection after finishing work. If a DTC is detected, perform trouble diagnosis according to self-diagnosis results.

For vehicle with steering lock unit, if the battery is disconnected or discharged, the steering wheel will lock and cannot be turned.

If turning the steering wheel is required with the battery disconnected or discharged, follow the operation procedure below before starting the repair operation.

OPERATION PROCEDURE

1. Connect both battery cables.
 - NOTE:**
Supply power using jumper cables if battery is discharged.
2. Turn the push-button ignition switch to ACC position.
(At this time, the steering lock will be released.)
3. Disconnect both battery cables. The steering lock will remain released with both battery cables disconnected and the steering wheel can be turned.
4. Perform the necessary repair operation.

A
B
C
FAX
E
F
G
H
I
J
K
L
M
N
O
P

PRECAUTIONS

< PRECAUTION >

[2WD]

-
5. When the repair work is completed, re-connect both battery cables. With the brake pedal released, turn the push-button ignition switch from ACC position to ON position, then to LOCK position. (The steering wheel will lock when the push-button ignition switch is turned to LOCK position.)
 6. Perform self-diagnosis check of all control units using CONSULT-III.

PREPARATION

< PREPARATION >

[2WD]

PREPARATION

PREPARATION

Commercial Service Tools

INFOID:000000006225414

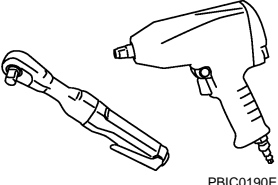
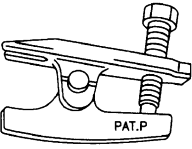
Tool name	Description
<p data-bbox="167 415 277 441">Power tool</p>  <p data-bbox="829 632 901 646">PBIC0190E</p>	<p data-bbox="1011 415 1263 441">Loosening bolts and nuts</p>
<p data-bbox="167 667 342 693">Ball joint remover</p>  <p data-bbox="792 821 829 835">PAT.P</p> <p data-bbox="829 884 868 898">NT146</p>	<ul data-bbox="1011 667 1430 718" style="list-style-type: none">• Removing ball joint for steering knuckle• Removing hub bolt

A

B

C

FAX

E

F

G

H

I

J

K

L

M

N

O

P

NOISE, VIBRATION AND HARSHNESS (NVH) TROUBLESHOOTING

< SYMPTOM DIAGNOSIS >

[2WD]

SYMPTOM DIAGNOSIS

NOISE, VIBRATION AND HARSHNESS (NVH) TROUBLESHOOTING

NVH Troubleshooting Chart

INFOID:000000006225415

Use chart below to find the cause of the symptom. If necessary, repair or replace these parts.

Reference		FAX-8	—	FAX-7	NVH in FAX and FSU sections	NVH in WT section	NVH in WT section	NVH in BR section	NVH in ST section
Possible cause and SUSPECTED PARTS		Improper installation, looseness	Parts interference	Wheel bearing damage	FRONT AXLE AND FRONT SUSPENSION	TIRE	ROAD WHEEL	BRAKE	STEERING
Symptom	FRONT AXLE	Noise	x	x	x	x	x	x	x
		Shake	x	x	x	x	x	x	x
		Vibration	x	x	x	x			x
		Shimmy	x	x		x	x	x	x
		Judder	x			x	x	x	x
		Poor quality ride or handling	x	x		x	x		

x: Applicable

FRONT WHEEL HUB AND KNUCKLE

< PERIODIC MAINTENANCE >

[2WD]

PERIODIC MAINTENANCE

FRONT WHEEL HUB AND KNUCKLE

Inspection

INFOID:000000006225416

MOUNTING INSPECTION

Make sure that the mounting conditions (looseness, backlash) of each component and component conditions (wear, damage) are normal.

WHEEL BEARING INSPECTION

- Move wheel hub and bearing assembly in the axial direction by hand. Make sure there is no looseness of wheel hub and bearing assembly.

Axial end play : Refer to [FAX-10, "Wheel Hub and Bearing Assembly"](#).

- Rotate wheel hub and bearing assembly and make sure that is no unusual noise or other irregular conditions. If there is any of irregular conditions, replace wheel hub and bearing assembly.

A
B
C
FAX
E
F
G
H
I
J
K
L
M
N
O
P

FRONT WHEEL HUB AND KNUCKLE

< REMOVAL AND INSTALLATION >

[2WD]

REMOVAL AND INSTALLATION

FRONT WHEEL HUB AND KNUCKLE

Exploded View

INFOID:000000006225418

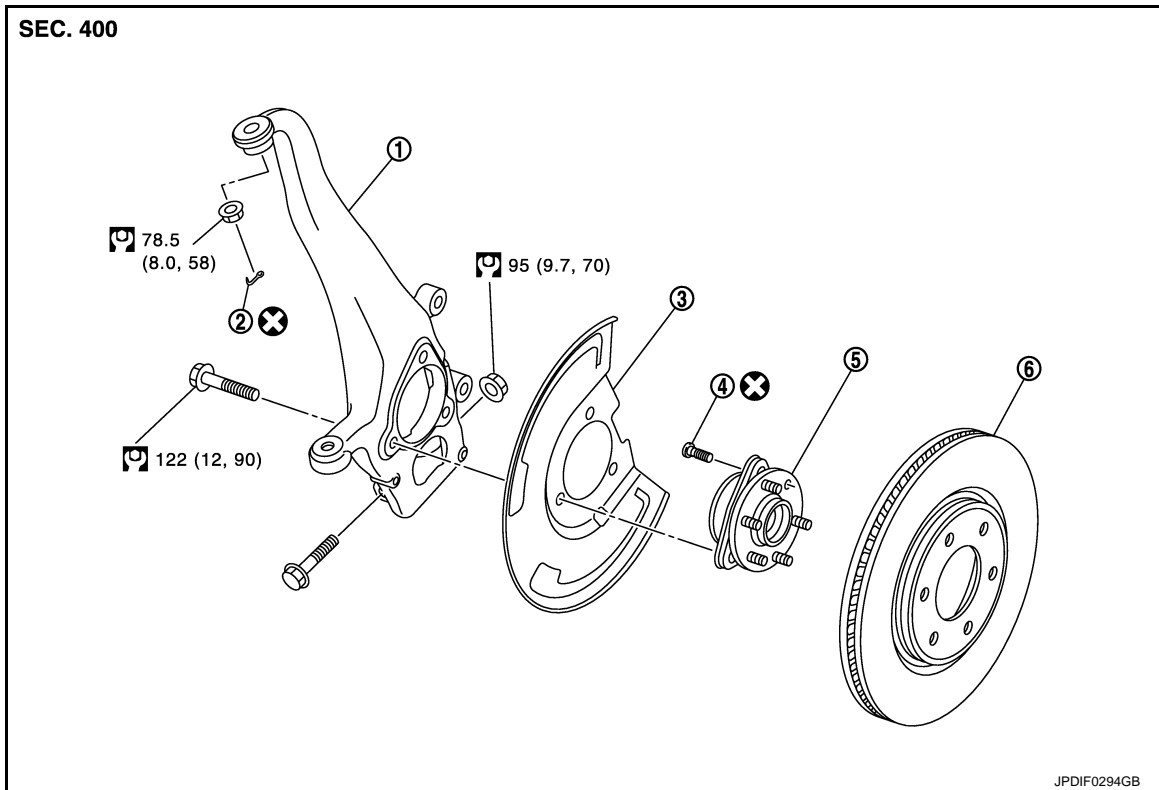

- | | | |
|---------------------|-----------------------------------|-----------------|
| 1. Steering knuckle | 2. Cotter pin | 3. Splash guard |
| 4. Hub bolt | 5. Wheel hub and bearing assembly | 6. Disc rotor |

Refer to [GI-4, "Components"](#) for symbols in the figure.

Removal and Installation

INFOID:000000006225419

REMOVAL

1. Remove tires with power tool. Refer to [WT-64, "Removal and Installation"](#).
2. Remove brake hose bracket. Refer to [BR-23, "FRONT : Removal and Installation"](#).
3. Remove caliper assembly mounting bolts. Hang caliper assembly in a place where it will not interfere with work. Refer to [BR-37, "BRAKE CALIPER ASSEMBLY : Removal and Installation"](#).
CAUTION:
Never depress brake pedal while brake caliper is removed.
4. Remove disc rotor.
CAUTION:
 - Put matching marks on the wheel hub and bearing assembly and the disc rotor before removing the disc rotor.
 - Never drop disc rotor.
5. Remove wheel sensor harness. Refer to [BRC-134, "FRONT WHEEL SENSOR : Removal and Installation"](#).
CAUTION:
Never pull on wheel sensor harness.
6. Remove steering outer socket. Refer to [ST-42, "Removal and Installation"](#).
7. Set suitable jack under lower link.

FRONT WHEEL HUB AND KNUCKLE

[2WD]

< REMOVAL AND INSTALLATION >

- Remove shock absorber mounting bolt from lower link. Refer to [FSU-10, "Removal and Installation"](#).
- Separate upper link from steering knuckle, using the ball joint remover (commercial service tool), and remove upper link.

CAUTION:

- Temporarily tighten the nut to prevent damage to threads and to prevent the ball joint remover from suddenly coming off.
- Never damage ball joint boot.

- Remove wheel hub and bearing assembly, and then remove splash guard.

- Remove lower link from steering knuckle.

CAUTION:

Never damage ball joint boot.

- Remove steering knuckle.

- Remove hub bolts (1) from wheel hub and bearing assembly, using the ball joint remover (A) (commercial service tool).

CAUTION:

- Remove hub bolt only when necessary.
- Never hammer the hub bolt to avoid impact to the wheel hub and bearing assembly.
- Pull out the hub bolt in a direction perpendicular to the wheel hub and bearing assembly.

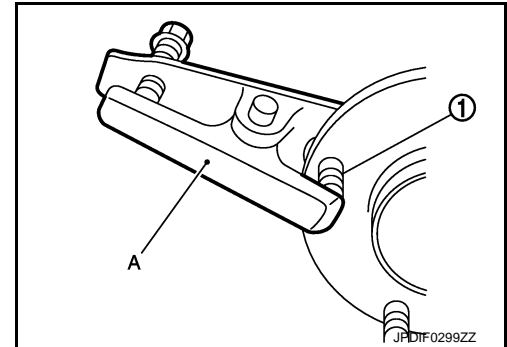

- Perform inspection after removal. Refer to [FAX-9, "Inspection"](#).

INSTALLATION

Note the following, and install in the reverse order of removal.

- Place a suitable washer (A) as shown in the figure to install the hub bolts (1) by using the tightening force of the nut (B).

CAUTION:

- Check that there is no clearance between wheel hub and bearing assembly, and hub bolt.
- Never reuse hub bolt.
- Perform the final tightening of each of parts under unladen conditions, which were removed when removing wheel hub and bearing assembly and steering knuckle.
- Never reuse cotter pin.
- Perform inspection after installation. Refer to [FAX-9, "Inspection"](#).

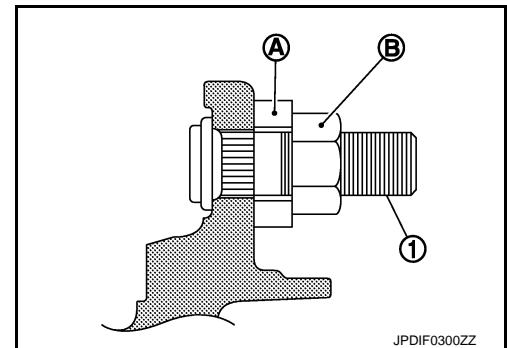

INFOID:000000006225420

Inspection

INSPECTION AFTER REMOVAL

Check components for deformation, cracks, and other damage. Replace it if necessary.

Ball Joint Inspection

Check boots of lower link and steering outer socket ball joint for breakage, axial play, and torque. Refer to [FSU-15, "Inspection"](#) and [ST-46, "Inspection"](#).

INSPECTION AFTER INSTALLATION

- Check wheel sensor harness for proper connection. Refer to [BRC-134, "FRONT WHEEL SENSOR : Exploded View"](#).
- Check the wheel alignment. Refer to [FSU-7, "Inspection"](#).
- Adjust neutral position of steering angle sensor. Refer to [BRC-64, "Work Procedure"](#).

SERVICE DATA AND SPECIFICATIONS (SDS)

< SERVICE DATA AND SPECIFICATIONS (SDS)

[2WD]

SERVICE DATA AND SPECIFICATIONS (SDS)

SERVICE DATA AND SPECIFICATIONS (SDS)

Wheel Hub and Bearing Assembly

INFOID:000000006225429

Item	Standard
Axial end play	0.05 mm (0.002 in) or less

< PRECAUTION >

PRECAUTION

PRECAUTIONS

Precaution for Supplemental Restraint System (SRS) "AIR BAG" and "SEAT BELT PRE-TENSIONER"

INFOID:000000006271941

The Supplemental Restraint System such as "AIR BAG" and "SEAT BELT PRE-TENSIONER", used along with a front seat belt, helps to reduce the risk or severity of injury to the driver and front passenger for certain types of collision. This system includes seat belt switch inputs and dual stage front air bag modules. The SRS system uses the seat belt switches to determine the front air bag deployment, and may only deploy one front air bag, depending on the severity of a collision and whether the front occupants are belted or unbelted. Information necessary to service the system safely is included in the "SRS AIR BAG" and "SEAT BELT" of this Service Manual.

WARNING:

- To avoid rendering the SRS inoperative, which could increase the risk of personal injury or death in the event of a collision that would result in air bag inflation, all maintenance must be performed by an authorized NISSAN/INFINITI dealer.
- Improper maintenance, including incorrect removal and installation of the SRS, can lead to personal injury caused by unintentional activation of the system. For removal of Spiral Cable and Air Bag Module, see the "SRS AIR BAG".
- Do not use electrical test equipment on any circuit related to the SRS unless instructed to in this Service Manual. SRS wiring harnesses can be identified by yellow and/or orange harnesses or harness connectors.

PRECAUTIONS WHEN USING POWER TOOLS (AIR OR ELECTRIC) AND HAMMERS

WARNING:

- When working near the Air Bag Diagnosis Sensor Unit or other Air Bag System sensors with the ignition ON or engine running, DO NOT use air or electric power tools or strike near the sensor(s) with a hammer. Heavy vibration could activate the sensor(s) and deploy the air bag(s), possibly causing serious injury.
- When using air or electric power tools or hammers, always switch the ignition OFF, disconnect the battery, and wait at least 3 minutes before performing any service.

Precaution Necessary for Steering Wheel Rotation after Battery Disconnect

INFOID:000000006271943

NOTE:

- Before removing and installing any control units, first turn the push-button ignition switch to the LOCK position, then disconnect both battery cables.
- After finishing work, confirm that all control unit connectors are connected properly, then re-connect both battery cables.
- Always use CONSULT-III to perform self-diagnosis as a part of each function inspection after finishing work. If a DTC is detected, perform trouble diagnosis according to self-diagnosis results.

For vehicle with steering lock unit, if the battery is disconnected or discharged, the steering wheel will lock and cannot be turned.

If turning the steering wheel is required with the battery disconnected or discharged, follow the operation procedure below before starting the repair operation.

OPERATION PROCEDURE

1. Connect both battery cables.
 - NOTE:**
Supply power using jumper cables if battery is discharged.
2. Turn the push-button ignition switch to ACC position.
(At this time, the steering lock will be released.)
3. Disconnect both battery cables. The steering lock will remain released with both battery cables disconnected and the steering wheel can be turned.
4. Perform the necessary repair operation.

A
B
C
E
F
G
H
I
J
K
L
M
N
O
P

FAX

PRECAUTIONS

[4WD]

< PRECAUTION >

5. When the repair work is completed, re-connect both battery cables. With the brake pedal released, turn the push-button ignition switch from ACC position to ON position, then to LOCK position. (The steering wheel will lock when the push-button ignition switch is turned to LOCK position.)
6. Perform self-diagnosis check of all control units using CONSULT-III.

Precautions for Drive Shaft

INFOID:000000006225390

- Observe the following precautions when disassembling and assembling drive shaft.
 - Never disassemble joint sub-assembly because it is non-overhaul parts.
 - Perform work in a location which is as dust-free as possible.
 - Clean the parts, before disassembling and assembling.
 - Prevent the entry of foreign objects during disassembly of the service location.
 - Reassemble disassembled parts carefully in the correct order. If work is interrupted, a clean cover must be placed over parts.
 - Use paper waste. Fabric shop cloths must not be used because of the danger of lint adhering to parts.
 - Clean disassembled parts (except for rubber parts) with kerosene which shall be removed by blowing with air or wiping with paper waste.

PREPARATION

< PREPARATION >

[4WD]



PREPARATION

PREPARATION

Special Service Tools

INFOID:000000006225391

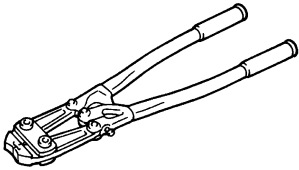
The actual shapes of Kent-Moore tools may differ from those of special service tools illustrated here.

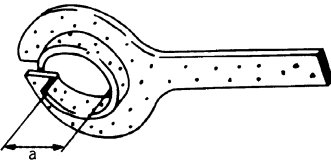
Tool number (Kent-Moore No.) Tool name		Description
KV40107300 (-) Boot band crimping tool	 <p style="text-align: center; font-size: small;">ZZA1229D</p>	Installing boot band
KV40107500 (-) Drive shaft attachment	 <p style="text-align: center; font-size: small;">ZZA1230D</p>	Removing drive shaft
KV38106300 (-) Protector a: 35 mm (1.38 in) dia.	 <p style="text-align: center; font-size: small;">PDA1183J</p>	Installing drive shaft

Commercial Service Tools

INFOID:000000006225392

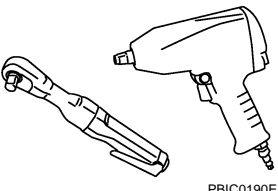
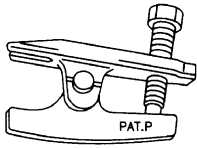
Tool name		Description
Power tool	 <p style="text-align: center; font-size: small;">PBIC0190E</p>	Loosening bolts and nuts
Ball joint remover	 <p style="text-align: center; font-size: small;">NT146</p>	<ul style="list-style-type: none"> Removing ball joint for steering knuckle Removing hub bolt

PREPARATION

< PREPARATION >

[4WD]

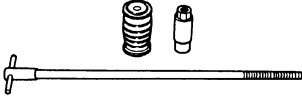
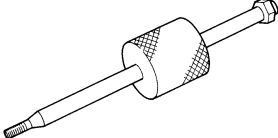
Tool name	Description
<p data-bbox="162 197 332 226">Drive shaft puller</p>  <p data-bbox="824 415 912 432">JPDIG0152ZZ</p>	<p data-bbox="1006 197 1412 226">Removing drive shaft joint sub assembly</p>
<p data-bbox="162 449 324 478">Sliding hummer</p>  <p data-bbox="824 667 896 684">ZZA0023D</p>	<p data-bbox="1006 449 1226 478">Removing drive shaft</p>

NOISE, VIBRATION AND HARSHNESS (NVH) TROUBLESHOOTING

< SYMPTOM DIAGNOSIS >

[4WD]

SYMPTOM DIAGNOSIS

NOISE, VIBRATION AND HARSHNESS (NVH) TROUBLESHOOTING

NVH Troubleshooting Chart

INFOID:000000006225393

Use chart below to find the cause of the symptom. If necessary, repair or replace these parts.

Reference			—	FAX-28	—	FAX-18	—	FAX-16	NVH in FAX and FSU sections	Refer to FRONT AXLE in this chart.	NVH in WT section	NVH in WT section	Refer to DRIVE SHAFT in this chart.	NVH in BR section	NVH in ST section	
Possible cause and SUSPECTED PARTS			Excessive joint angle	Joint sliding resistance	Imbalance	Improper installation, looseness	Parts interference	Wheel bearing damage	FRONT AXLE AND FRONT SUSPENSION	FRONT AXLE	TIRE	ROAD WHEEL	DRIVE SHAFT	BRAKE	STEERING	
Symptom	DRIVE SHAFT	Noise	x	x				x	x	x	x	x	x	x	x	
		Shake	x		x			x	x	x	x	x		x	x	
	FRONT AXLE	Noise				x	x	x	x		x	x	x	x	x	x
		Shake				x	x	x	x		x	x	x	x	x	x
		Vibration				x	x	x	x		x		x			x
		Shimmy				x	x		x		x	x		x	x	x
		Judder				x			x		x	x		x	x	x
		Poor quality ride or handling				x	x		x		x	x				

x: Applicable

A
B
C
E
F
G
H
I
J
K
L
M
N
O
P

FAX

PERIODIC MAINTENANCE

FRONT WHEEL HUB AND KNUCKLE

Inspection

INFOID:000000006225394

MOUNTING INSPECTION

Make sure that the mounting conditions (looseness, backlash) of each component and component conditions (wear, damage) are normal.

WHEEL BEARING INSPECTION

- Move wheel hub and bearing assembly in the axial direction by hand. Make sure there is no looseness of wheel hub and bearing assembly.

Axial end play : Refer to [FAX-29, "Wheel Hub and Bearing Assembly"](#).

- Rotate wheel hub and bearing assembly and make sure that is no unusual noise or other irregular conditions. If there is any of irregular conditions, replace wheel hub and bearing assembly.

FRONT DRIVE SHAFT

< PERIODIC MAINTENANCE >

[4WD]

FRONT DRIVE SHAFT

Inspection

INFOID:000000006225395

Check the following items, and replace the part if necessary.

- Check drive shaft mounting point and joint for looseness and other damage.

CAUTION:

Replace entire drive shaft assembly when noise or vibration occurs from drive shaft.

- Check boot for cracks and other damage.

A

B

C

FAX

E

F

G

H

I

J

K

L

M

N

O

P

FRONT WHEEL HUB AND KNUCKLE

< REMOVAL AND INSTALLATION >

[4WD]

REMOVAL AND INSTALLATION

FRONT WHEEL HUB AND KNUCKLE

Exploded View

INFOID:000000006225396

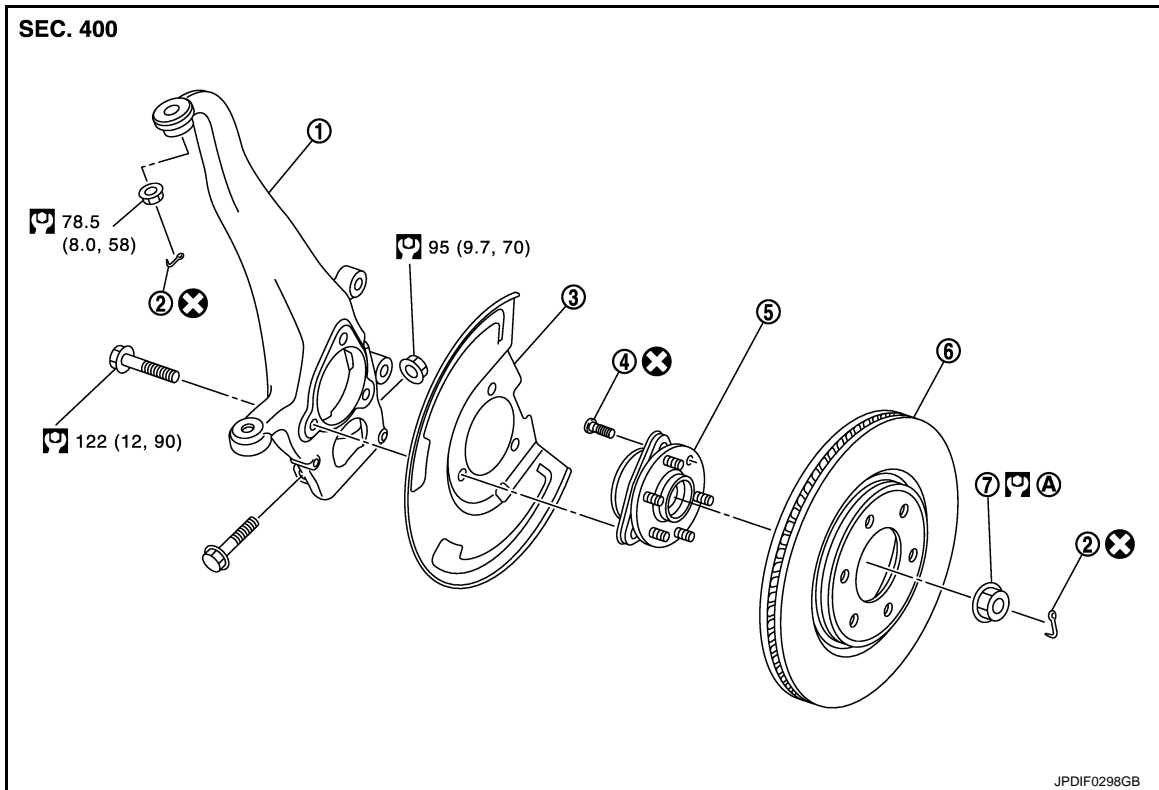

- | | | |
|-----------------------|-----------------------------------|-----------------|
| 1. Steering knuckle | 2. Cotter pin | 3. Splash guard |
| 4. Hub bolt | 5. Wheel hub and bearing assembly | 6. Disc rotor |
| 7. Wheel hub lock nut | | |
- A. Tightening must be done following the installation procedure. Refer to [FAX-18, "Removal and Installation"](#).
Refer to [GI-4, "Components"](#) for symbols in the figure.

Removal and Installation

INFOID:000000006225397

REMOVAL

1. Remove tires.
2. Remove brake hose bracket. Refer to [BR-23, "FRONT : Removal and Installation"](#).
3. Remove caliper assembly mounting bolts. Hang caliper assembly in a place where it will not interfere with work. Refer to [BR-37, "BRAKE CALIPER ASSEMBLY : Removal and Installation"](#).
CAUTION:
Never depress brake pedal while brake caliper is removed.
4. Remove disc rotor.
CAUTION:
 - Put matching marks on the wheel hub and bearing assembly and the disc rotor before removing the disc rotor.
 - Never drop disc rotor.
5. Remove wheel sensor harness. Refer to [BRC-134, "FRONT WHEEL SENSOR : Removal and Installation"](#).
CAUTION:
Never pull on wheel sensor harness.
6. Remove steering outer socket. Refer to [ST-42, "Removal and Installation"](#).

FRONT WHEEL HUB AND KNUCKLE

[4WD]

< REMOVAL AND INSTALLATION >

7. Set suitable jack under lower link.
8. Remove shock absorber mounting bolt from lower link. Refer to [FSU-10, "Removal and Installation"](#).
9. Separate upper link from steering knuckle, using the ball joint remover (commercial service tool), and remove upper link.
CAUTION:
 - Temporarily tighten the nut to prevent damage to threads and to prevent the ball joint remover from suddenly coming off.
 - Never damage ball joint boot.
10. Remove cotter pin, and then loosen wheel hub lock nut.
11. Put matching mark on drive shaft and wheel hub and bearing assembly.
CAUTION:
Use paint or similar substance for matching marks. Never scratch the surface.
12. Patch wheel hub lock nut with a piece of wood. Hammer the wood to disengage wheel hub and bearing assembly from drive shaft.
CAUTION:
 - Never place drive shaft joint at an extreme angle. Also be careful not to overextend slide joint.
 - Never allow drive shaft to hang down without support for or joint sub-assembly, shaft and the other parts.**NOTE:**
Use suitable puller, if wheel hub and bearing assembly and drive shaft cannot be separated even after performing the above procedure.
13. Remove wheel hub lock nut.
14. Remove wheel hub and bearing assembly, and then remove splash guard.
15. Remove lower link from steering knuckle.
CAUTION:
Never damage ball joint boot.
16. Remove steering knuckle.
17. Remove hub bolts (1) from wheel hub and bearing assembly, using the ball joint remover (A) (commercial service tool).
CAUTION:
 - Remove hub bolt only when necessary.
 - Never hammer the hub bolt to avoid impact to the wheel hub and bearing assembly.
 - Pull out the hub bolt in a direction perpendicular to the wheel hub and bearing assembly.
18. Perform inspection after removal. Refer to [FAX-20, "Inspection"](#).

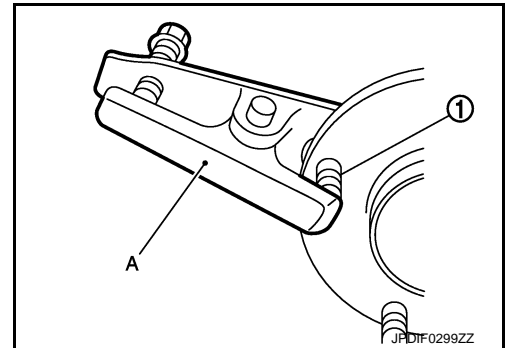

INSTALLATION

Note the following, and install in the reverse order of removal.

- Place a suitable washer (A) as shown in the figure to install the hub bolts (1) by using the tightening force of the nut (B).
- CAUTION:**
- Check that there is no clearance between wheel hub and bearing assembly, and hub bolt.
 - Never reuse hub bolt.
- Use the following torque range for tightening the wheel hub lock nut.

 : 118 – 123 N·m (12.1 – 12.5 kg·m, 87 – 90 ft·lb)

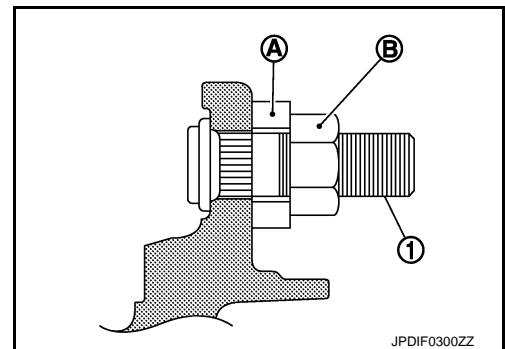

CAUTION:

- Since the drive shaft is assembled by press-fitting, use the tightening torque range for the wheel hub lock nut.
- Be sure to use torque wrench to tighten the wheel hub lock nut. Never use a power tool.
- Perform the final tightening of each of parts under unladen conditions, which were removed when removing wheel hub and bearing assembly and steering knuckle.

FRONT WHEEL HUB AND KNUCKLE

[4WD]

< REMOVAL AND INSTALLATION >

- Never reuse cotter pin.
- Perform inspection after installation. Refer to [FAX-20, "Inspection"](#).

Inspection

INFOID:000000006225398

INSPECTION AFTER REMOVAL

Check components for deformation, cracks, and other damage. Replace it if necessary.

Ball Joint Inspection

Check boots of lower link and steering outer socket ball joint for breakage, axial play, and torque. Refer to [FSU-15, "Inspection"](#) and [ST-46, "Inspection"](#).

INSPECTION AFTER INSTALLATION

1. Check wheel sensor harness for proper connection. Refer to [BRC-134, "FRONT WHEEL SENSOR : Exploded View"](#).
2. Check the wheel alignment. Refer to [FSU-7, "Inspection"](#).
3. Adjust neutral position of steering angle sensor. Refer to [BRC-64, "Work Procedure"](#).

FRONT DRIVE SHAFT BOOT

< REMOVAL AND INSTALLATION >

[4WD]

FRONT DRIVE SHAFT BOOT

Exploded View

INFOID:000000006225399

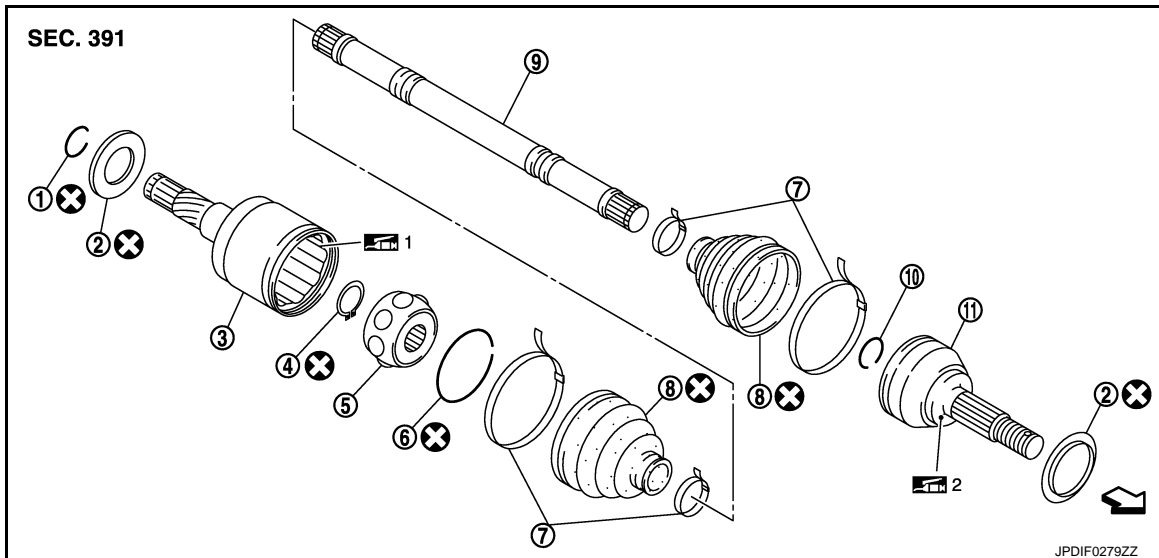

- | | | |
|-------------------|---|-----------------|
| 1. Circular clip | 2. Dust shield | 3. Housing |
| 4. Snap ring | 5. Ball cage/steel ball/inner race assembly | 6. Stopper ring |
| 7. Boot band | 8. Boot | 9. Shaft |
| 10. Circular clip | 11. Joint sub-assembly | |

↔ : Wheel side

: NISSAN genuine grease or an equivalent.

Refer to [GI-4, "Components"](#) for symbols not described on the above.

Removal and Installation

INFOID:000000006225400

NOTE:

Remove boot after drive shaft is removed from the vehicle.

- Remove and install drive shaft. Refer to [FAX-22, "Removal and Installation"](#).
- Disassembly and assembly drive shaft. Refer to [FAX-23, "WHEEL SIDE : Disassembly and Assembly"](#) (wheel side) or [FAX-26, "FINAL DRIVE SIDE : Disassembly and Assembly"](#) (final drive side).

Inspection

INFOID:000000006225401

INSPECTION AFTER REMOVAL

- Move joint up/down, left/right, and in the axial directions. Check for motion that is not smooth and for significant looseness.
- Check boot for cracks, damage, and leakage of grease.
- Disassemble drive shaft and exchange malfunctioning part if there is a non-standard condition.

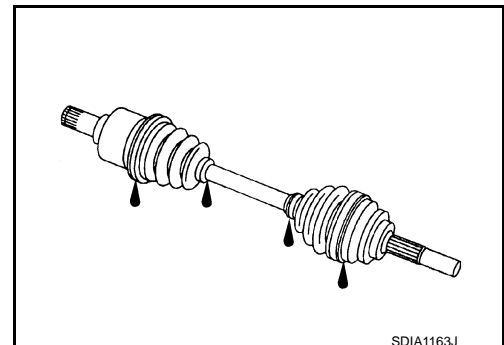

SDIA1163J

FRONT DRIVE SHAFT

< REMOVAL AND INSTALLATION >

[4WD]

FRONT DRIVE SHAFT

Exploded View

INFOID:000000006225402

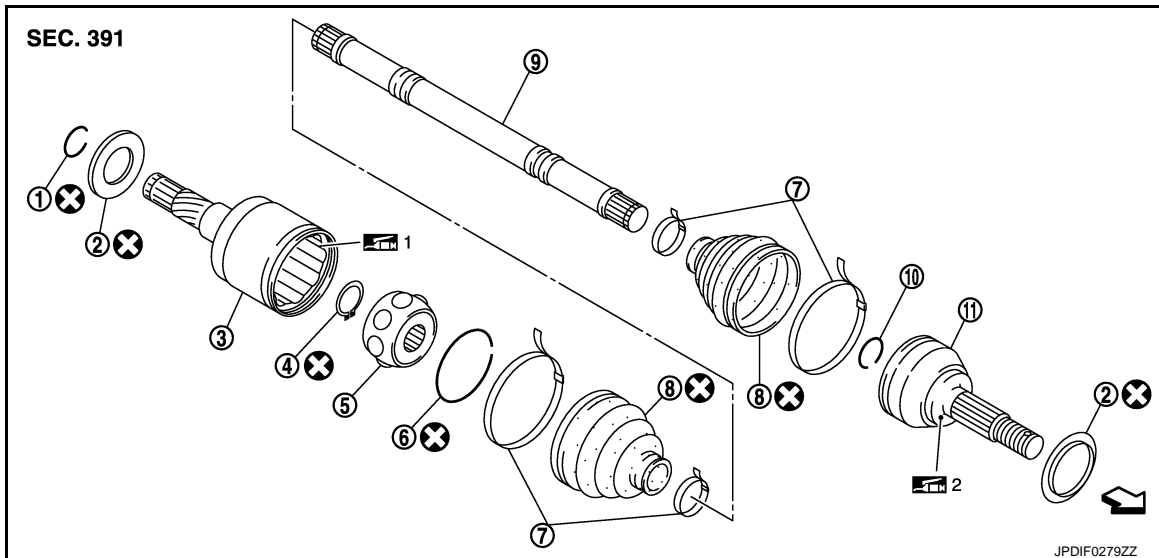

- | | | |
|-------------------|---|-----------------|
| 1. Circular clip | 2. Dust shield | 3. Housing |
| 4. Snap ring | 5. Ball cage/steel ball/inner race assembly | 6. Stopper ring |
| 7. Boot band | 8. Boot | 9. Shaft |
| 10. Circular clip | 11. Joint sub-assembly | |

↔ : Wheel side

 : NISSAN genuine grease or an equivalent.

Refer to [GI-4, "Components"](#) for symbols not described on the above.

Removal and Installation

INFOID:000000006225403

REMOVAL

1. Remove tires.
2. Remove brake hose bracket. Refer to [BR-23, "FRONT : Removal and Installation"](#).
3. Remove caliper assembly mounting bolts. Hang caliper assembly in a place where it will not interfere with work. Refer to [BR-37, "BRAKE CALIPER ASSEMBLY : Removal and Installation"](#).
CAUTION:
Never depress brake pedal while brake caliper is removed.
4. Remove disc rotor. Refer to [FAX-18, "Removal and Installation"](#).
5. Remove wheel sensor harness. Refer to [BRC-134, "FRONT WHEEL SENSOR : Removal and Installation"](#).
CAUTION:
Never pull on wheel sensor harness.
6. Remove height sensor from upper link (right side). Refer to [EXL-136, "Removal and Installation"](#).
7. Remove steering outer socket. Refer to [ST-42, "Removal and Installation"](#).
8. Set suitable jack under lower link.
9. Remove shock absorber mounting bolt from lower link. Refer to [FSU-10, "Removal and Installation"](#).
10. Separate upper link from steering knuckle, using the ball joint remover (commercial service tool), and remove upper link.
CAUTION:
 - Temporarily tighten the nut to prevent damage to threads and to prevent the ball joint remover from suddenly coming off.

FRONT DRIVE SHAFT

[4WD]

< REMOVAL AND INSTALLATION >

- **Never damage ball joint boot.**

11. Remove cotter pin, and then loosen wheel hub lock nut.
12. Patch wheel hub lock nut with a piece of wood. Hammer the wood to disengage wheel hub and bearing assembly from drive shaft.

CAUTION:

- **Never place drive shaft joint at an extreme angle. Also be careful not to overextend slide joint.**
- **Never allow drive shaft to hang down without support for or joint sub-assembly, shaft and the other parts.**

NOTE:

Use suitable puller, if wheel hub and bearing assembly and drive shaft cannot be separated even after performing the above procedure.

13. Remove wheel hub lock nut.
14. Remove fender protector. Refer to [EXT-23. "FENDER PROTECTOR : Removal and Installation"](#).
15. Remove drive shaft from front final drive using the drive shaft attachment [SST: KV40107500 (-)] (A) and a sliding hammer (commercial service tool) (B) while inserting tip of the drive shaft attachment between housing and front final drive.

CAUTION:

- **Never place drive shaft joint at an extreme angle when removing drive shaft. Also be careful not to overextend slide joint.**
- **Confirm that the circular clip is attached to the drive shaft.**

16. Perform inspection after removal. Refer to [FAX-28. "Inspection"](#).

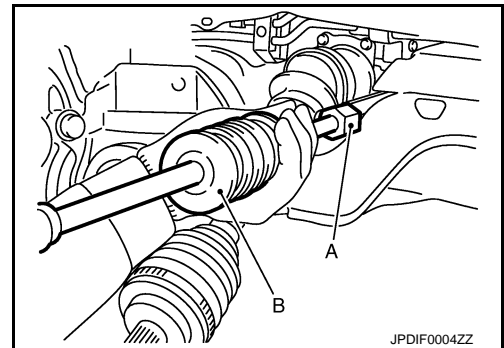

INSTALLATION

Note the following, and install in the reverse order of removal.

CAUTION:

Always replace final drive side oil seal with new one when installing drive shaft. Refer to [DLN-160. "Removal and Installation"](#)

- Place the protector [SST: KV38106300 (-)] (A) onto final drive to prevent damage to the oil seal while inserting drive shaft. Slide drive shaft sliding joint and tap with a hammer to install securely.

CAUTION:

Check that circular clip is completely engaged.

- Use the following torque range for tightening the wheel hub lock nut.

 : 118 – 123 N·m (12.1 – 12.5 kg·m, 87 – 90 ft·lb)

CAUTION:

- **Since the drive shaft is assembled by press-fitting, use the tightening torque range for the wheel hub lock nut.**
- **Be sure to use torque wrench to tighten the wheel hub lock nut. Never use a power tool.**
- Perform the final tightening of each of parts under unladen conditions, which were removed when removing wheel hub and bearing assembly and steering knuckle.
- Never reuse cotter pin.
- Perform inspection after installation. Refer to [FAX-28. "Inspection"](#).

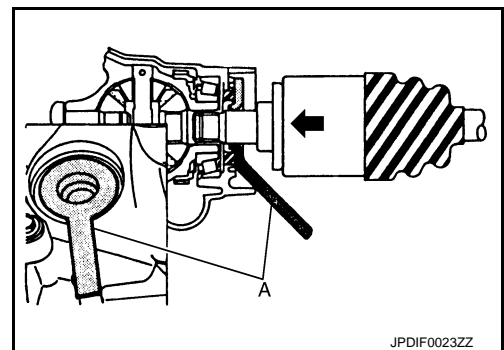

WHEEL SIDE

WHEEL SIDE : Disassembly and Assembly

INFOID:000000006225404

DISASSEMBLY

1. Fix shaft with a vise.

CAUTION:

Protect shaft when fixing with a vise using aluminum or copper plates.

2. Remove dust shield from joint sub-assembly.
3. Remove boot bands and then remove boot from joint sub-assembly.

FRONT DRIVE SHAFT

[4WD]

< REMOVAL AND INSTALLATION >

4. Screw the drive shaft puller (commercial service tool) (A) 30 mm (1.18 in) or more into the thread of joint sub-assembly, and pull joint sub-assembly from shaft.

CAUTION:

- If joint sub-assembly cannot be removed after five or more unsuccessful attempts, replace shaft and joint sub assembly as a set.
- Align drive shaft puller and drive shaft and remove them by pulling directory.

5. Remove circular clip from shaft.
6. Remove boot from shaft.
7. Perform inspection after disassembly. Refer to [FAX-28, "Inspection"](#).

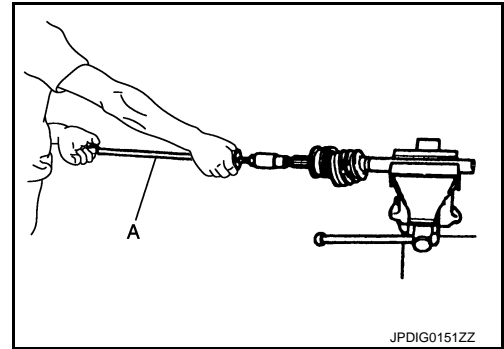

ASSEMBLY

1. While rotating ball cage, clean old grease on joint sub-assembly with paper waste.
2. Fill serration slot joint sub-assembly (1) with NISSAN genuine grease or equivalent until the serration slot and ball groove become full to the brim.

CAUTION:

After applying grease, use a shop cloth to wipe off old grease that has oozed out.

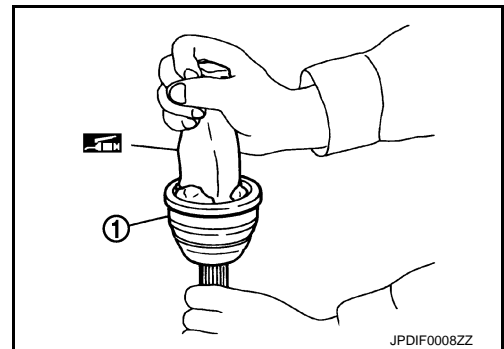

3. Install boot and boot bands to shaft.
CAUTION:
 - Wrap serration on shaft with tape (A) to protect the boot from damage.
 - Never reuse boot and boot band.
4. Remove the tape wrapped around the serration on shaft.
5. Position circular clip on groove at the shaft edge.

CAUTION:

Never reuse circular clip.

NOTE:

Drive joint inserter is recommended when installing circular clip.

6. Align both center axles of the shaft edge and joint sub-assembly. Then assemble shaft with joint sub-assembly holding circular clip.
7. Install joint sub-assembly to shaft using plastic hammer.

CAUTION:

Confirm that joint sub-assembly is correctly engaged while rotating drive shaft.

8. Apply the specified amount of grease into the boot inside from large diameter side of boot.

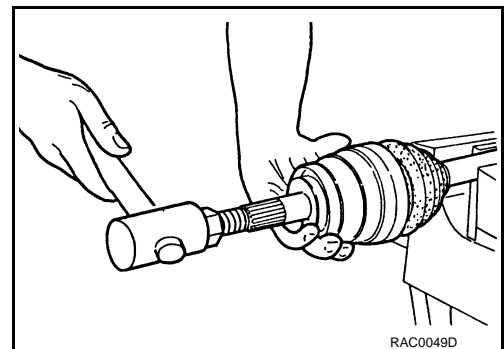
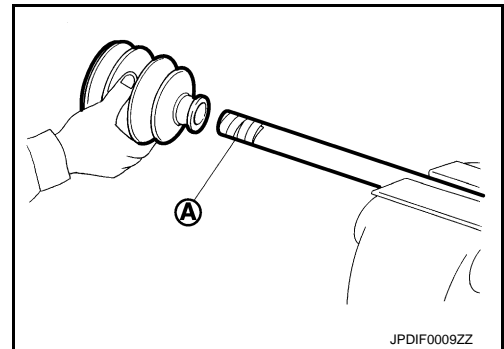

Grease amount : Refer to [FAX-29, "Drive Shaft"](#).

FRONT DRIVE SHAFT

[4WD]

< REMOVAL AND INSTALLATION >

9. Install the boot securely into grooves (indicated by "*" marks) shown in the figure.

CAUTION:

If grease adheres to the boot mounting surface (indicated by "*" mark) on the shaft or housing, boot may come off. Remove all grease from the surfaces.

10. To prevent the deformation of the boot, adjust the boot installation length (L) to the specified value shown below by inserting the suitable tool into inside of the boot from the large diameter side of boot and discharging the inside air.

L : Refer to [FAX-29, "Drive Shaft"](#).

CAUTION:

- If the boot installation length is outside the standard, it may cause breakage of boot.
- Be careful not to touch the inside of the boot with the tip of tool.

11. Install new boot bands securely.

CAUTION:

Never reuse boot band.

- a. Small boot band

- i. Secure the ends of the boot with boot bands using the boot band crimping tool [SST: KV40107300 (-)] (A).

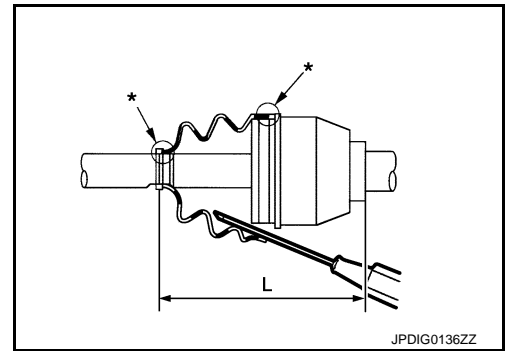

JPDIG0136ZZ

A
B
C

FAX

E

F

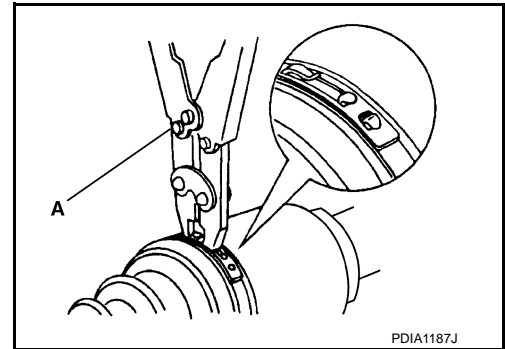

PDIA1187J

G
H
I
J

CAUTION:

Secure boot band so that dimension (M) meets the specification as shown in the figure.

M : 1.0 – 4.0 mm (0.039 – 0.157 in)

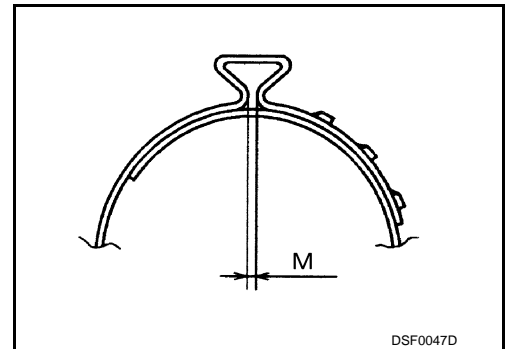

DSF0047D

K
L
M

- b. Large boot band

- i. Put boot band in the groove on drive shaft boot. Then fit pawls (←) into holes to temporary installation.

NOTE:

For the large diameter side, fit projection (A) and guide slit (B) at first.

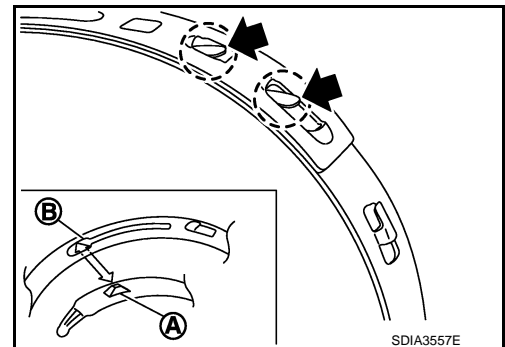

SDIA3557E

N
O
P

FRONT DRIVE SHAFT

[4WD]

< REMOVAL AND INSTALLATION >

- ii. Pinch projection on the band with suitable pliers to tighten band.
- iii. Insert tip of band below end of the pawl.
12. Secure joint sub-assembly and shaft, and then check that they are in the correct position when rotating boot. Install them with boot band when boot installation positions become incorrect.

CAUTION:

Never reuse boot band.

13. Install dust shield to joint sub-assembly.

CAUTION:

Never reuse dust shield.

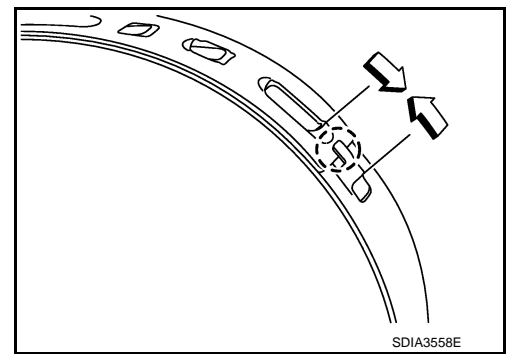

FINAL DRIVE SIDE

FINAL DRIVE SIDE : Disassembly and Assembly

INFOID:000000006225405

DISASSEMBLY

1. Fix shaft with a vise.

CAUTION:

Protect shaft when fixing with a vise using aluminum or copper plates.

2. Remove circular clip from housing.
3. Remove dust shield from housing.
4. Remove boot bands, and then remove boot from housing.
5. Put matching marks on housing and shaft.

CAUTION:

Use paint or similar substance for matching marks. Never scratch the surface.

6. Remove stopper ring with suitable tool, and pull out housing.
7. Put matching marks on ball cage/steel ball/inner race assembly and shaft.

CAUTION:

Use paint or similar substance for matching marks. Never scratch the surface.

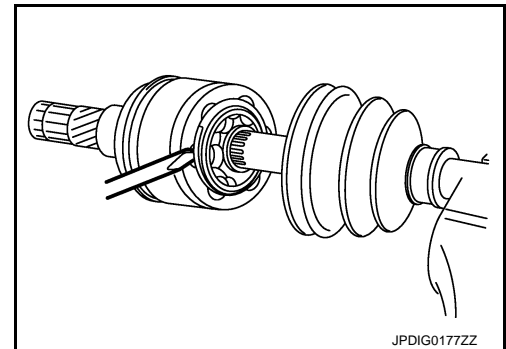

8. Remove snap ring, then remove ball cage/steel ball/inner race assembly from shaft.
9. Remove boot from shaft.
10. Perform inspection after disassembly. Refer to [FAX-28. "Inspection"](#).

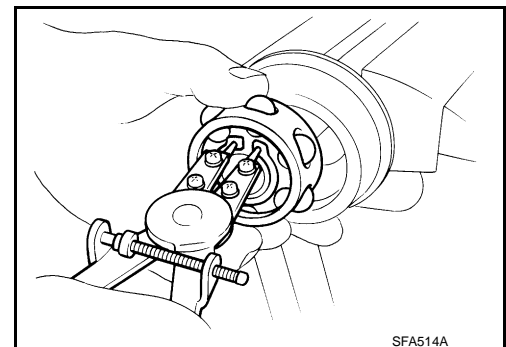

ASSEMBLY

1. Remove old grease on housing with paper waste.

FRONT DRIVE SHAFT

[4WD]

< REMOVAL AND INSTALLATION >

2. Install boot and boot bands to shaft.

CAUTION:

- Wrap serration on shaft with tape (A) to protect the boot from damage.
- Never reuse boot and boot band.

3. Remove the tape wrapped around the serration on shaft.

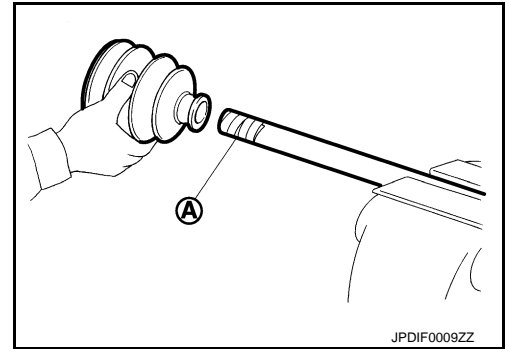

4. Install ball cage/steel ball/inner race assembly (1), align it with the matching marks on shaft (2) put during the removal.

5. Secure ball cage/steel ball/inner race assembly onto shaft with snap ring (3).

CAUTION:

Never reuse snap ring.

6. Apply the appropriate amount of grease onto housing and sliding surface.

Grease amount : Refer to [FAX-29, "Drive Shaft"](#).

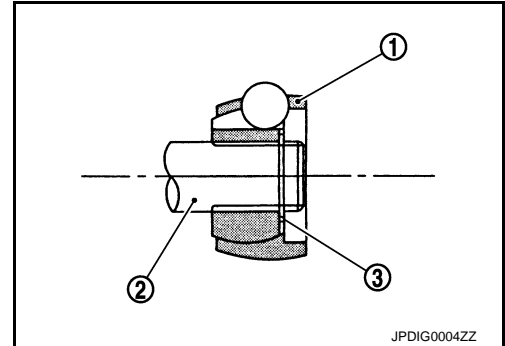

7. Install housing to shaft.

8. Install stopper ring to housing.

CAUTION:

Never reuse stopper ring.

9. After installed, pull shaft to check engagement between housing and stopper ring.

10. Install boot securely into grooves (indicated by "*" marks) shown in the figure.

CAUTION:

If grease adheres to the boot mounting surfaces (indicated by "*" marks) on shaft or housing, boot may be removed. Remove all grease from the surfaces.

11. To prevent deformation of the boot, adjust the boot installation length (L) to the value shown below by inserting the suitable tool into the inside of boot from the large diameter side of boot and discharging inside air.

L : Refer to [FAX-29, "Drive Shaft"](#).

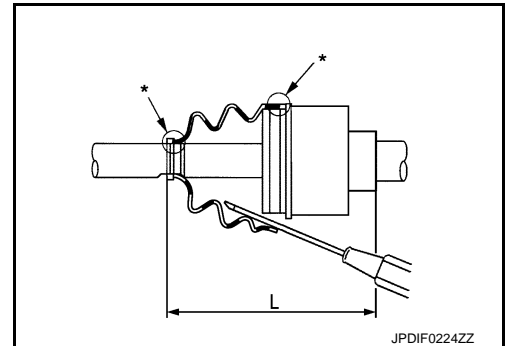

CAUTION:

- If the boot installation length is outside the standard, it may cause breakage of boot.
- Be careful not to touch the inside of the boot with the tip of tool.

12. Install boot bands securely as shown in the figure.

CAUTION:

Never reuse boot band.

13. Secure housing and shaft, and then check that they are in the correct position when rotating boot. Install them with boot band when the mounting positions become incorrect.

CAUTION:

Never reuse boot band.

14. Install dust shield to housing.

CAUTION:

Never reuse dust shield.

15. Install circular clip to housing.

CAUTION:

Never reuse circular clip.

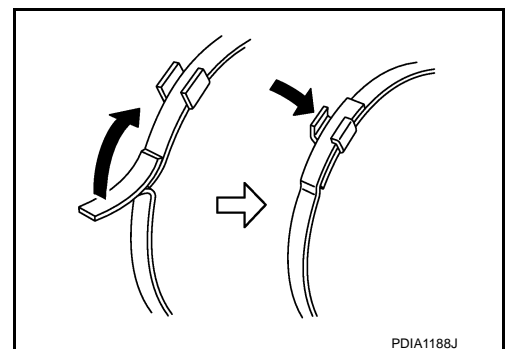

A
B
C
FAX
E
F
G
H
I
J
K
L
M
N
O
P

FRONT DRIVE SHAFT

< REMOVAL AND INSTALLATION >

[4WD]

INFOID:000000006225406

Inspection

INSPECTION AFTER REMOVAL

- Move joint up/down, left/right, and in the axial directions. Check for motion that is not smooth and for significant looseness.
- Check boot for cracks, damage, and leakage of grease.
- Disassemble drive shaft and exchange malfunctioning part if there is a non-standard condition.

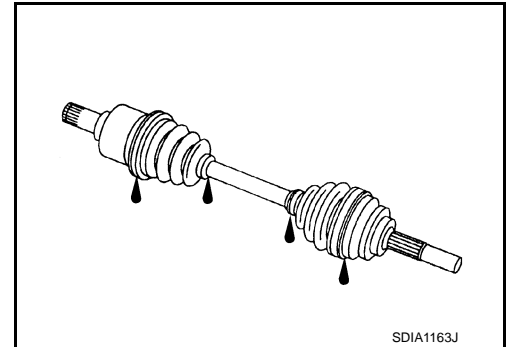

INSPECTION AFTER DISASSEMBLY

Shaft

Check shaft for runout, cracks, or other damage. Replace it if necessary.

Joint Sub-Assembly (Wheel Side)

Check the following items, replace the parts if necessary.

- Joint sub-assembly for rough rotation and excessive axial looseness.
- The inside of the joint sub-assembly for entry of foreign material.
- Joint sub-assembly for compression scars, cracks, and fractures inside of joint sub-assembly.

Replace joint sub-assembly if there are any non-standard conditions of components.

Housing (Final Drive side)

Replace housing if there is scratching or wear of housing roller contact surface.

INSPECTION AFTER INSTALLATION

1. Check wheel sensor harness for proper connection. Refer to [BRC-134, "FRONT WHEEL SENSOR : Exploded View"](#).
2. Check the wheel alignment. Refer to [FSU-7, "Inspection"](#).
3. Adjust neutral position of steering angle sensor. Refer to [BRC-64, "Work Procedure"](#).
4. Adjust levelizer adjustment of height sensor. Refer to [EXL-61, "LEVELIZER ADJUSTMENT : Special Repair Requirement"](#).

SERVICE DATA AND SPECIFICATIONS (SDS)

< SERVICE DATA AND SPECIFICATIONS (SDS)

[4WD]

SERVICE DATA AND SPECIFICATIONS (SDS)

SERVICE DATA AND SPECIFICATIONS (SDS)

Wheel Hub and Bearing Assembly

INFOID:0000000006225407

Item	Standard
Axial end play	0.05 mm (0.002 in) or less

Drive Shaft

INFOID:0000000006225408

Item	Standard	
	Wheel side	Final drive side
Grease quantity	205 – 225 g (7.23 – 7.94 oz)	130 – 150 g (4.59 – 5.29 oz)
Boots installed length	157.8 mm (6.21 in)	196.4 mm (7.73 in)

A
B
C
FAX
E
F
G
H
I
J
K
L
M
N
O
P