

SECTION **IP**
INSTRUMENT PANEL

A
B
C
D
E
F
G
H
I
IP
K
L
M
N
O
P

CONTENTS

PRECAUTION	2	SQUEAK AND RATTLE TROUBLE DIAG- NOSES	7
PRECAUTIONS	2	Work Flow	7
Precaution for Supplemental Restraint System (SRS) "AIR BAG" and "SEAT BELT PRE-TEN- SIONER"	2	Inspection Procedure	9
Precaution Necessary for Steering Wheel Rota- tion after Battery Disconnect	2	Diagnostic Worksheet	11
Service	3	REMOVAL AND INSTALLATION	13
PREPARATION	4	INSTRUMENT PANEL ASSEMBLY	13
PREPARATION	4	Exploded View	13
Special Service Tools	4	Removal and Installation	14
Commercial Service Tools	4	CENTER CONSOLE ASSEMBLY	23
CLIP LIST	6	Exploded View	23
Clip List	6	Removal and Installation	25
SYMPTOM DIAGNOSIS	7	Disassembly and Assembly	27
		REAR CONSOLE ASSEMBLY	29
		Exploded View	29
		Removal and Installation	29
		Disassembly and Assembly	30

PRECAUTIONS

< PRECAUTION >

PRECAUTION

PRECAUTIONS

Precaution for Supplemental Restraint System (SRS) "AIR BAG" and "SEAT BELT PRE-TENSIONER"

INFOID:000000006113088

The Supplemental Restraint System such as "AIR BAG" and "SEAT BELT PRE-TENSIONER", used along with a front seat belt, helps to reduce the risk or severity of injury to the driver and front passenger for certain types of collision. This system includes seat belt switch inputs and dual stage front air bag modules. The SRS system uses the seat belt switches to determine the front air bag deployment, and may only deploy one front air bag, depending on the severity of a collision and whether the front occupants are belted or unbelted. Information necessary to service the system safely is included in the "SRS AIR BAG" and "SEAT BELT" of this Service Manual.

WARNING:

- To avoid rendering the SRS inoperative, which could increase the risk of personal injury or death in the event of a collision that would result in air bag inflation, all maintenance must be performed by an authorized NISSAN/INFINITI dealer.
- Improper maintenance, including incorrect removal and installation of the SRS, can lead to personal injury caused by unintentional activation of the system. For removal of Spiral Cable and Air Bag Module, see the "SRS AIR BAG".
- Do not use electrical test equipment on any circuit related to the SRS unless instructed to in this Service Manual. SRS wiring harnesses can be identified by yellow and/or orange harnesses or harness connectors.

PRECAUTIONS WHEN USING POWER TOOLS (AIR OR ELECTRIC) AND HAMMERS

WARNING:

- When working near the Air Bag Diagnosis Sensor Unit or other Air Bag System sensors with the ignition ON or engine running, DO NOT use air or electric power tools or strike near the sensor(s) with a hammer. Heavy vibration could activate the sensor(s) and deploy the air bag(s), possibly causing serious injury.
- When using air or electric power tools or hammers, always switch the ignition OFF, disconnect the battery, and wait at least 3 minutes before performing any service.

Precaution Necessary for Steering Wheel Rotation after Battery Disconnect

INFOID:000000006113089

NOTE:

- Before removing and installing any control units, first turn the push-button ignition switch to the LOCK position, then disconnect both battery cables.
- After finishing work, confirm that all control unit connectors are connected properly, then re-connect both battery cables.
- Always use CONSULT-III to perform self-diagnosis as a part of each function inspection after finishing work. If a DTC is detected, perform trouble diagnosis according to self-diagnosis results.

For vehicle with steering lock unit, if the battery is disconnected or discharged, the steering wheel will lock and cannot be turned.

If turning the steering wheel is required with the battery disconnected or discharged, follow the operation procedure below before starting the repair operation.

OPERATION PROCEDURE

1. Connect both battery cables.

NOTE:

Supply power using jumper cables if battery is discharged.

2. Turn the push-button ignition switch to ACC position.
(At this time, the steering lock will be released.)
3. Disconnect both battery cables. The steering lock will remain released with both battery cables disconnected and the steering wheel can be turned.
4. Perform the necessary repair operation.

PRECAUTIONS

< PRECAUTION >

5. When the repair work is completed, re-connect both battery cables. With the brake pedal released, turn the push-button ignition switch from ACC position to ON position, then to LOCK position. (The steering wheel will lock when the push-button ignition switch is turned to LOCK position.)
6. Perform self-diagnosis check of all control units using CONSULT-III.

Service

INFOID:000000006113090

- Disconnect battery negative terminal in advance.
- Disconnect air bag system line in advance.
- Never tamper with or force air bag lid open, as this may adversely affect air bag performance.
- Be careful not to scratch pad and other parts.
- When removing or disassembling any part, be careful not to damage or deform it. Protect parts, that may get in the way with a shop cloth.
- When removing parts with a screwdriver or other tool, cover the tool surface with vinyl tape to protect parts.
- Keep removed parts protected with a shop cloth.
- If a clip is deformed or damaged, replace it.
- If an un reusable part is removed, replace it with a new one.
- Tighten bolts and nuts firmly to the specified torque.
- After reassembly is complete, check that each part functions correctly.
- Remove stains via the following procedure.

Water-soluble stains:

Dip a soft cloth in warm water, and then squeeze it tightly. After wiping off the stain, wipe with a soft dry cloth.

Oil stain:

Dissolve a synthetic detergent in warm water (density of 2 to 3%), dip the cloth, then wipe off the stain with the cloth. Next, dip the cloth in fresh water and squeeze it tightly. Then wipe off the detergent completely. Then wipe the area with a soft dry cloth.

- Never use any organic solvent, such as thinner or benzine.

A
B
C
D
E
F
G
H
I
K
L
M
N
O
P

IP

PREPARATION

< PREPARATION >

PREPARATION

PREPARATION

Special Service Tools

INFOID:000000006113091

The actual shapes of Kent-Moore tools may differ from those of special service tools illustrated here.

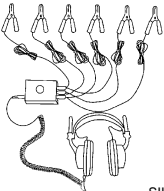
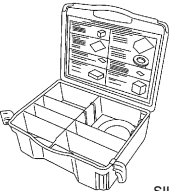
Tool number (Kent-Moore No.) Tool name	Description
(J-39570) Chassis ear  SIIA0993E	Locates the noise
(J-43980) NISSAN Squeak and Rattle Kit  SIIA0994E	Repairs the cause of noise

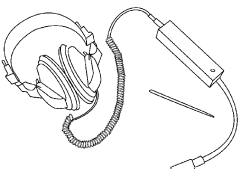
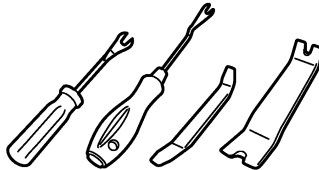

Commercial Service Tools

INFOID:000000006113092

Tool name	Description
Engine ear  SIIA0995E	Locates the noise
Remover tool  JMKIA3050ZZ	Removes clips, pawls, and metal clips

PREPARATION

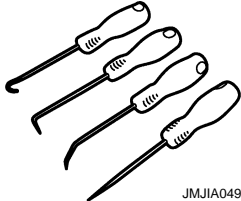
< PREPARATION >

Tool name	Description
<p data-bbox="159 300 347 329">Hook and pick tool</p>  <p data-bbox="776 415 862 432">JMJA0490ZZ</p>	<p data-bbox="1008 300 1299 329">Removes rear console cover</p>
<p data-bbox="159 552 269 581">Power tool</p>  <p data-bbox="776 663 846 680">PIIB1407E</p>	

A
B
C
D
E
F
G
H
I
K
L
M
N
O
P

IP

CLIP LIST

< PREPARATION >

CLIP LIST

Clip List

INFOID:000000006113093

Shapes	Removal & Installation	Shapes	Removal & Installation
	<p>Removal: Remove by bending up with flat-bladed screwdrivers or clip remover.</p>		<p>Removal:</p>
	<p>Removal: Remove with a clip remover.</p>		<p>Removal:</p>
	<p>Removal: Push center pin to catching position. (Do not remove center pin by hitting it.)</p> <p>Installation:</p>		<p>Removal: Holder portion of clip must be spread out to remove rod.</p>
	<p>Removal: Remove by bending up with flat-bladed screwdrivers or clip remover.</p>		<p>Removal:</p> <ol style="list-style-type: none"> Screw out with a Phillips screwdriver. Remove female portion with flat-bladed screwdriver.
	<p>Removal:</p>		<p>Removal:</p> <p>Rotate 45° to remove.</p> <p>Installation:</p>
	<p>Removal:</p>		<p>Removal:</p>

JMJIA3734GB

SQUEAK AND RATTLE TROUBLE DIAGNOSES

< SYMPTOM DIAGNOSIS >

SYMPTOM DIAGNOSIS

SQUEAK AND RATTLE TROUBLE DIAGNOSES

Work Flow

INFOID:000000006425523

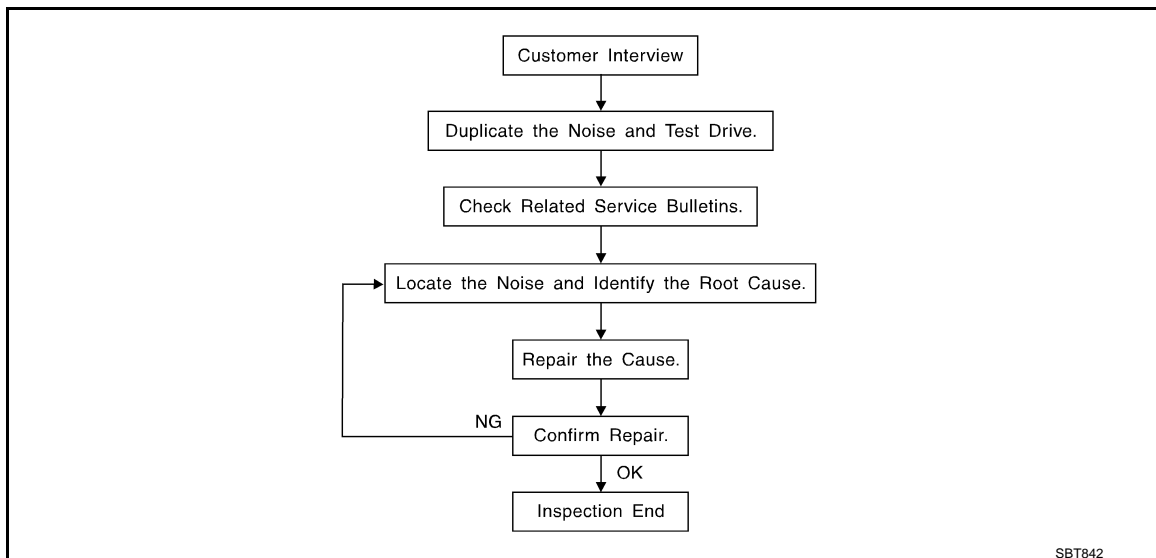

CUSTOMER INTERVIEW

Interview the customer if possible, to determine the conditions that exist when the noise occurs. Use the Diagnostic Worksheet during the interview to document the facts and conditions when the noise occurs and any customer comments. Refer to [IP-11, "Diagnostic Worksheet"](#). This information is necessary to duplicate the conditions that exist when the noise occurs.

- The customer may not be able to provide a detailed description or the location of the noise. Attempt to obtain all the facts and conditions that exist when the noise occurs (or does not occur).
- If there is more than one noise in the vehicle, perform a diagnosis and repair the noise that the customer is concerned about. This can be accomplished by performing a test drive with the customer.
- After identifying the type of noise, isolate the noise in terms of its characteristics. The noise characteristics are provided so that the customer, service adviser, and technician use the same language when describing the noise.
- Squeak – (Like tennis shoes on a clean floor)
Squeak characteristics include the light contact / fast movement / brought on by road conditions / hard surfaces = high-pitched noise / softer surfaces = low-pitched noises / edge to surface = chirping
- Creak – (Like walking on an old wooden floor)
Creak characteristics include firm contact / slow movement/twisting with a rotational movement / pitch dependent on materials / often brought on by activity.
- Rattle – (Like shaking a baby rattle)
Rattle characteristics include fast repeated contact / vibration or similar movement / loose parts/missing clip or fastener / incorrect clearance.
- Knock – (Like a knock on a door)
Knock characteristics include hollow sounds / sometimes repeating / often brought on by driver action.
- Tick – (Like a clock second hand)
Tick characteristics include gentle contacting of light materials / loose components / can be caused by driver action or road conditions.
- Thump – (Heavy, muffled knock noise)
Thump characteristics include softer knock / dull sounds often brought on by activity.
- Buzz – (Like a bumblebee)
Buzz characteristics include high frequency rattle / firm contact.
- Often the degree of acceptable noise level varies depending upon the person. A noise that a technician may judge as acceptable may be very irritating to a customer.
- Weather conditions, especially humidity and temperature, may have a great effect on noise level.

DUPLICATE THE NOISE AND TEST DRIVE

SQUEAK AND RATTLE TROUBLE DIAGNOSES

< SYMPTOM DIAGNOSIS >

If possible, drive the vehicle with the customer until the noise is duplicated. Note any additional information on the Diagnostic Worksheet regarding the conditions or location of the noise. This information can be used to duplicate the same conditions when the repair is reconfirmed.

If the noise can be duplicated easily during the test drive, do the following with the vehicle stopped to help identify the source of the noise.

- 1) Close a door.
 - 2) Tap or push/pull around the area where the noise appears to be coming from.
 - 3) Rev the engine.
 - 4) Use a floor jack to recreate vehicle "twist".
 - 5) At idle, apply engine load (electrical load, half-clutch on M/T models, drive position on A/T models).
 - 6) Raise the vehicle on a hoist and hit a tire with a rubber hammer.
- Drive the vehicle and attempt to duplicate the conditions the customer states exist when the noise occurs.
 - If it is difficult to duplicate the noise, drive the vehicle slowly on an undulating or rough road to stress the vehicle body.

CHECK RELATED SERVICE BULLETINS

After verifying the customer concern or symptom, check ASIST for Technical Service Bulletins (TSBs) related to the concern or symptom.

If a TSB relates to the symptom, follow the procedure to repair the noise.

LOCATE THE NOISE AND IDENTIFY THE ROOT CAUSE

1. Narrow down the noise to a general area. To help pinpoint the source of the noise, use a listening tool (Chassis ear: J-39570, engine ear, and mechanics stethoscope).
2. Narrow down the noise to a more specific area and identify the cause of the noise by:
 - Removing the component(s) in the area(s) that is / are suspected to be the cause of the noise. Do not use too much force when removing clips and fasteners, otherwise clips and fasteners can be broken or lost during the repair, creating a new noise.
 - Tapping or pushing/pulling the component(s) that is / are suspected to be the cause of the noise. Do not tap or push/pull the component(s) with excessive force, otherwise the noise is eliminated only temporarily.
 - Feeling for a vibration by hand by touching the component(s) that is / are suspected to be the cause of the noise.
 - Placing a piece of paper between components that are suspected to be the cause of the noise.
 - Looking for loose components and contact marks.
Refer to [IP-9, "Inspection Procedure"](#).

REPAIR THE CAUSE

- If the cause is a loose component, tighten the component securely.
- If the cause is insufficient clearance between components:
 - Separate components by repositioning or loosening and retightening the components, if possible.
 - Insulate components with a suitable insulator such as urethane pads, foam blocks, felt cloth tape, or urethane tape. A NISSAN Squeak and Rattle Kit (J-43980) is available through the authorized NISSAN Parts Department.

CAUTION:

Never use excessive force as many components are constructed of plastic and may be damaged.

NOTE:

Always check with the Parts Department for the latest parts information.

The following materials are contained in the NISSAN Squeak and Rattle Kit (J-43980). Each item can be ordered separately as needed.

URETHANE PADS [1.5 mm (0.059 in) thick]

Insulates connectors, harness, etc.

- 76268-9E005: 100 × 135 mm (3.937 × 5.315 in)
- 76884-71L01: 60 × 85 mm (2.362 × 3.346 in)
- 76884-71L02: 15 × 25 mm (0.591 × 0.984 in)

INSULATOR (Foam blocks)

Insulates components from contact. Can be used to fill space behind a panel.

- 73982-9E000: 45 mm (1.772 in) thick, 50 × 50 mm (1.969 × 1.969 in)
- 73982-50Y00: 10 mm (0.394 in) thick, 50 × 50 mm (1.969 × 1.969 in)

INSULATOR (Light foam block)

80845-71L00: 30 mm (1.18 in) thick, 30 × 50 mm (1.181 × 1.969 in)

FELT CLOTHTAPE

SQUEAK AND RATTLE TROUBLE DIAGNOSES

< SYMPTOM DIAGNOSIS >

Used to insulate where movement does not occur. Ideal for instrument panel applications.

- 68370-4B000: 15 × 25 mm (0.591 × 0.984 in) pad
- 68239-13E00: 5 mm (0.197 in) wide tape roll

The following materials, not found in the kit, can also be used to repair squeaks and rattles.

UHMW (TEFLON) TAPE

Insulates where slight movement is present. Ideal for instrument panel applications.

SILICONE GREASE

Used in place of UHMW tape that is visible or does not fit. Only lasts a few months.

SILICONE SPRAY

Used when grease cannot be applied.

DUCT TAPE

Used to eliminate movement.

CONFIRM THE REPAIR

After repair is complete, test drive the vehicle to confirm that the cause of noise is repaired by test driving the vehicle. Operate the vehicle under the same conditions as when the noise originally occurred. Refer to the notes on the Diagnostic Worksheet.

Inspection Procedure

INFOID:000000006425524

Refer to Table of Contents for specific component removal and installation information.

INSTRUMENT PANEL

Most incidents are caused by contact and movement between:

1. The cluster lid A and instrument panel
2. Acrylic lens and combination meter housing
3. Instrument panel to front pillar garnish
4. Instrument panel to windshield
5. Instrument panel mounting pins
6. Wiring harnesses behind the combination meter
7. A/C defroster duct and duct joint

These incidents can usually be located by tapping or moving the components to duplicate the noise or by pressing on the components while driving to stop the noise. Most of these incidents can be repaired by applying felt cloth tape or silicon spray (in hard to reach areas). Urethane pads can be used to insulate wiring harness.

CAUTION:

Never use silicone spray to isolate a squeak or rattle. If the area is saturated with silicone, the recheck of repair becomes impossible.

CENTER CONSOLE

Components to check include:

1. Shifter assembly cover to finisher
2. A/C control unit and cluster lid C
3. Wiring harnesses behind audio and A/C control unit

The instrument panel repair and isolation procedures also apply to the center console.

DOORS

Check the following items:

1. Finisher and inner panel making a slapping noise
2. Inside handle escutcheon connection to door finisher
3. Wiring harnesses tapping
4. Door striker out of alignment causing a popping noise on starts and stops

Tapping, moving the components, or pressing on them while driving to duplicate the conditions can isolate many of these incidents. The areas can usually be insulated with felt cloth tape or insulator foam blocks from the NISSAN Squeak and Rattle Kit (J-43980) to repair the noise.

TRUNK

Trunk noises are often caused by a loose jack or loose items put into the trunk by the customer.

In addition check for the following items:

SQUEAK AND RATTLE TROUBLE DIAGNOSES

< SYMPTOM DIAGNOSIS >

1. Trunk lid dumpers out of adjustment
2. Trunk lid striker out of adjustment
3. Trunk lid torsion bars knocking together
4. A loose license plate or bracket

Most of these incidents can be repaired by adjusting, securing, or insulating the item(s) or component(s) causing the noise.

SUNROOF/HEADLINING

Noises in the sunroof / headlining area can often be traced to one of the following items:

1. Sunroof lid, rail, linkage, or seals making a rattle or light knocking noise
2. Sunvisor shaft shaking in the holder
3. Front or rear windshield touching headlining and squeaking

Again, pressing on the components to stop the noise while duplicating the conditions can isolate most of these incidents. Repairs usually consist of insulating with felt cloth tape.

SEATS

When isolating seat noise it is important to note the position the seat is in and the load placed on the seat when the noise occurs. These conditions should be duplicated when verifying and isolating the cause of the noise.

Causes of seat noise include:

1. Headrest rods and holder
2. A squeak between the seat pad cushion and frame
3. The rear seatback lock and bracket

These noises can be isolated by moving or pressing on the suspected components while duplicating the conditions under which the noise occurs. Most of these incidents can be repaired by repositioning the component or applying urethane tape to the contact area.

UNDERHOOD

Some interior noise may be caused by components under the hood or on the engine wall. The noise is then transmitted into the passenger compartment.

Causes of transmitted underhood noise include:

1. Any component mounted to the engine wall
2. Components that pass through the engine wall
3. Engine wall mounts and connectors
4. Loose radiator mounting pins
5. Hood bumpers out of adjustment
6. Hood striker out of adjustment

These noises can be difficult to isolate since they cannot be reached from the interior of the vehicle. The best method is to secure, move, or insulate one component at a time and test drive the vehicle. Also, engine RPM or load can be changed to isolate the noise. Repairs can usually be made by moving, adjusting, securing, or insulating the component causing the noise.

SQUEAK AND RATTLE TROUBLE DIAGNOSES

< SYMPTOM DIAGNOSIS >

Diagnostic Worksheet

INFOID:000000006425525



SQUEAK & RATTLE DIAGNOSTIC WORKSHEET

Dear Infiniti Customer:

We are concerned about your satisfaction with your Infiniti vehicle. Repairing a squeak or rattle sometimes can be very difficult. To help us fix your Infiniti right the first time, please take a moment to note the area of the vehicle where the squeak or rattle occurs and under what conditions. You may be asked to take a test drive with a service consultant or technician to ensure we confirm the noise you are hearing.

I. WHERE DOES THE NOISE COME FROM? (circle the area of the vehicle)

The illustrations are for reference only, and may not reflect the actual configuration of your vehicle.

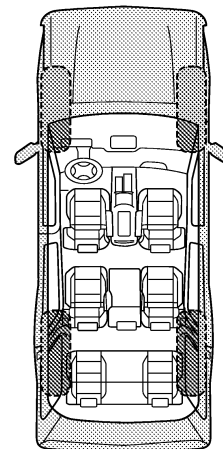
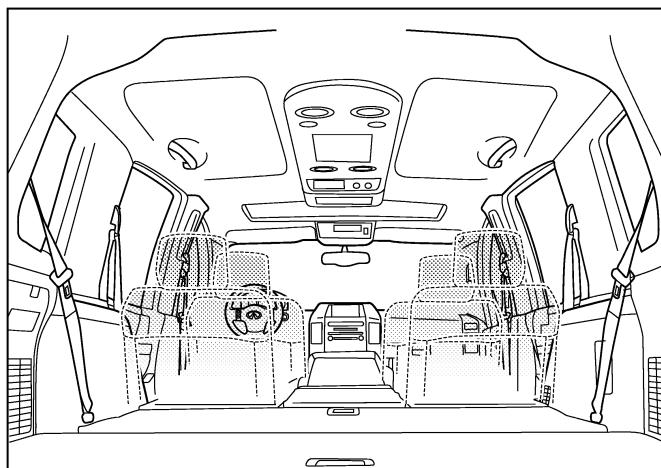
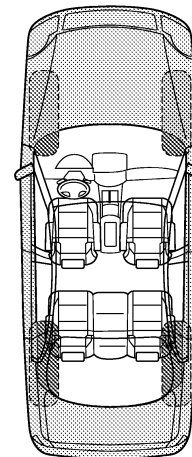
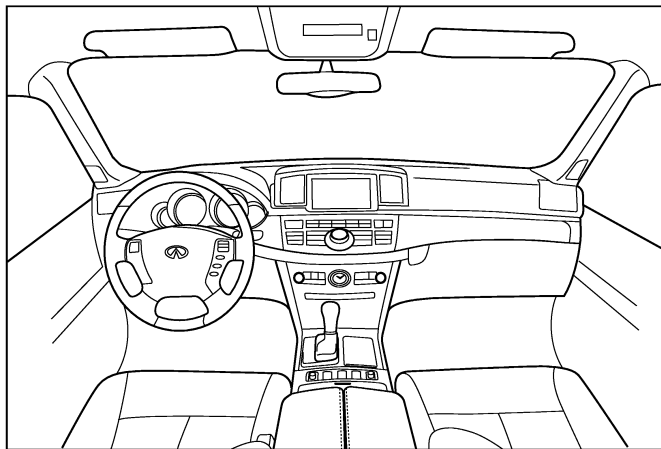

Continue to page 2 of the worksheet and briefly describe the location of the noise or rattle. In addition, please indicate the conditions which are present when the noise occurs.

PIIB8741E

A
B
C
D
E
F
G
H
I
IP
K
L
M
N
O
P

SQUEAK AND RATTLE TROUBLE DIAGNOSES

< SYMPTOM DIAGNOSIS >

SQUEAK & RATTLE DIAGNOSTIC WORKSHEET - page 2

Briefly describe the location where the noise occurs:

II. WHEN DOES IT OCCUR? (please check the boxes that apply)

- | | |
|---|--|
| <input type="checkbox"/> anytime | <input type="checkbox"/> after sitting out in the rain |
| <input type="checkbox"/> 1st time in the morning | <input type="checkbox"/> when it is raining or wet |
| <input type="checkbox"/> only when it is cold outside | <input type="checkbox"/> dry or dusty conditions |
| <input type="checkbox"/> only when it is hot outside | <input type="checkbox"/> other: |

III. WHEN DRIVING:

- through driveways
- over rough roads
- over speed bumps
- only about ____ mph
- on acceleration
- coming to a stop
- on turns: left, right or either (circle)
- with passengers or cargo
- other: _____
- after driving ____ miles or ____ minutes

IV. WHAT TYPE OF NOISE

- squeak (like tennis shoes on a clean floor)
- creak (like walking on an old wooden floor)
- rattle (like shaking a baby rattle)
- knock (like a knock at the door)
- tick (like a clock second hand)
- thump (heavy, muffled knock noise)
- buzz (like a bumble bee)

TO BE COMPLETED BY DEALERSHIP PERSONNEL

Test Drive Notes:

	YES	NO	Initials of person performing
Vehicle test driven with customer	<input type="checkbox"/>	<input type="checkbox"/>	_____
- Noise verified on test drive	<input type="checkbox"/>	<input type="checkbox"/>	_____
- Noise source located and repaired	<input type="checkbox"/>	<input type="checkbox"/>	_____
- Follow up test drive performed to confirm repair	<input type="checkbox"/>	<input type="checkbox"/>	_____

VIN: _____ Customer Name: _____
W.O.# _____ Date: _____

This form must be attached to Work Order

PIIB8742E

INSTRUMENT PANEL ASSEMBLY

< REMOVAL AND INSTALLATION >

REMOVAL AND INSTALLATION

INSTRUMENT PANEL ASSEMBLY

Exploded View

INFOID:000000006113097

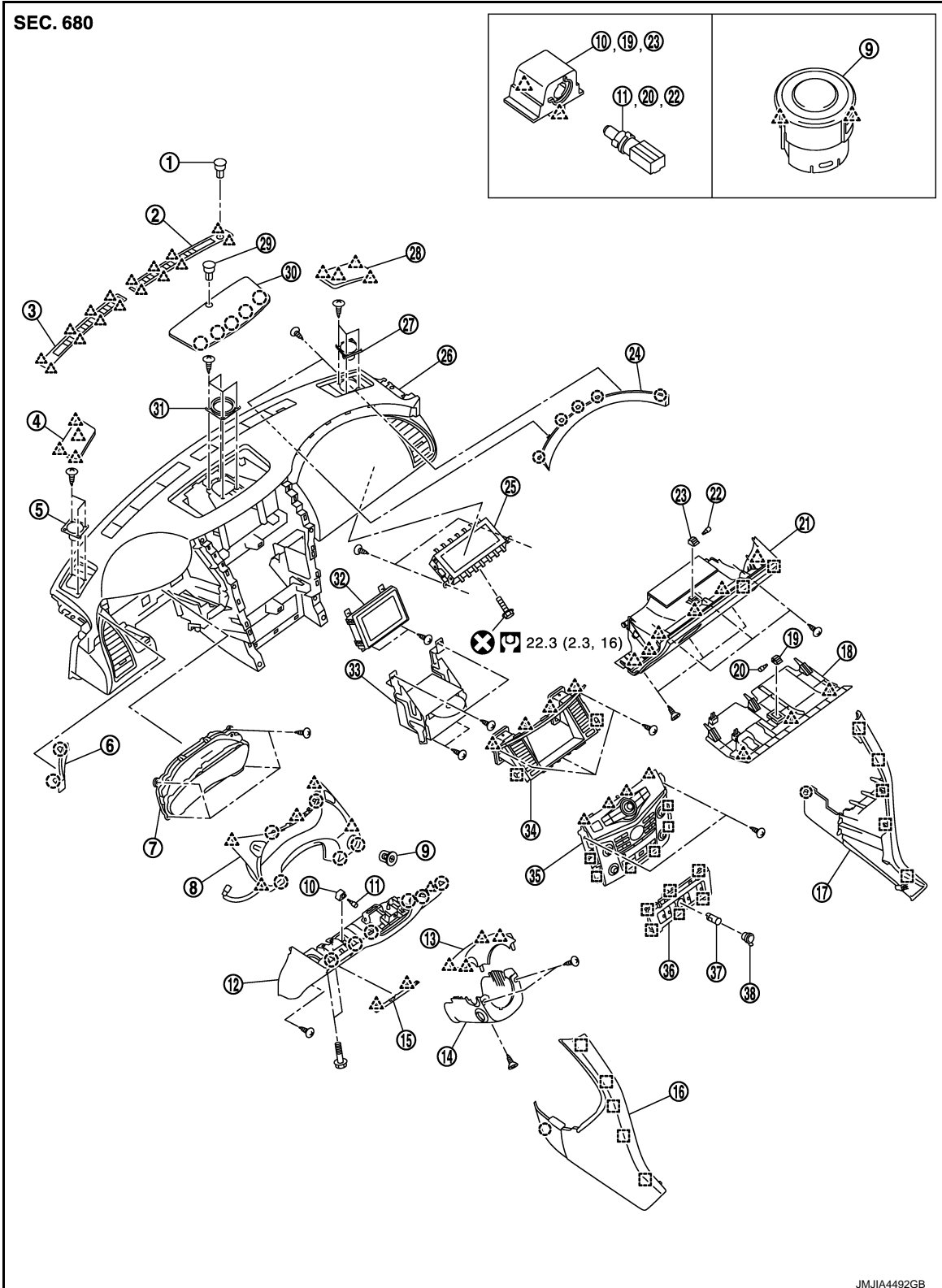



A
B
C
D
E
F
G
H
I
IP
K
L
M
N
O
P

INSTRUMENT PANEL ASSEMBLY

< REMOVAL AND INSTALLATION >

- | | | |
|------------------------------------|-----------------------------------|--------------------------------|
| 1. Optical sensor | 2. Front defroster grille RH | 3. Front defroster grille LH |
| 4. Speaker grille LH | 5. Squawker LH | 6. Instrument finisher A |
| 7. Combination meter | 8. Cluster lid A | 9. Push-button ignition switch |
| 10. Illumination lamp | 11. Socket and bulb | 12. Instrument lower panel LH |
| 13. Steering column upper cover | 14. Steering column lower cover | 15. Fuse block lid |
| 16. Instrument center finisher LH | 17. Instrument center finisher RH | 18. Instrument lower cover |
| 19. Illumination lamp | 20. Socket and bulb | 21. Glove box assembly |
| 22. Socket and bulb | 23. Illumination lamp | 24. Instrument finisher B |
| 25. Front passenger air bag module | 26. Instrument panel assembly | 27. Squawker RH |
| 28. Speaker grille RH | 29. Sunload sensor | 30. Upper ventilator grille |
| 31. Center speaker | 32. Front display unit | 33. AV control unit |
| 34. Cluster lid D | 35. Cluster lid C | 36. Cluster lid C lower |
| 37. Inner socket | 38. Socket knob | |

 : Clip

 : Pawl

 : Metal clip

Refer to [GI-4. "Components"](#) for symbols in the figure.

Removal and Installation

INFOID:000000006113098

WORK STEP

When removing instrument panel assembly, combination meter, front display unit, AV control unit, instrument finisher A, instrument finisher B, and center console assembly take steps as per the order shown in the following chart.

PARTS	INSTRUMENT PANEL ASSEMBLY	COMBINATION METER	FRONT DISPLAY UNIT	AV control unit	INSTRUMENT FINISHER A	INSTRUMENT FINISHER B	CENTER CONSOLE ASSEMBLY
Instrument lower cover	[1]		[1]	[1]		[1]	[1]
Glove box assembly	[2]					[2]	
Front passenger air bag module harness connector	[3]					[3]	
Front passenger air bag module mounting bolt	[4]					[4]	
Selector lever knob	[5]		[2]	[2]		[5]	[2]
Console finisher assembly	[6]		[3]	[3]		[6]	[3]
Instrument center finisher RH	[7]		[4]	[4]		[7]	[4]
Front body side welt RH	[8]					[8]	
Front pillar garnish RH	[9]					[9]	
Speaker grille RH	[10]					[10]	
Squawker RH	[11]					[11]	
Front defroster grille RH	[12]					[12]	
Front defroster grille LH	[13]					[13]	
Instrument center finisher LH	[14]		[5]	[5]		[14]	[5]
Console rear finisher	[15]					[15]	[6]
Center console assembly	[16]					[16]	[7]
Front body side welt LH	[17]	[1]			[1]	[17]	
Front pillar garnish LH	[18]					[18]	
Speaker grille LH	[19]					[19]	

INSTRUMENT PANEL ASSEMBLY

< REMOVAL AND INSTALLATION >

PARTS	INSTRUMENT PANEL ASSEMBLY	COMBINATION METER	FRONT DISPLAY UNIT	AV control unit	INSTRUMENT FINISHER A	INSTRUMENT FINISHER B	CENTER CONSOLE ASSEMBLY
Squawker LH	[20]					[20]	
Instrument lower panel LH	[21]	[2]			[2]	[21]	
Disconnect meter control switch harness connector	[22]	[3]			[3]	[22]	
Driver air bag module	[23]					[23]	
Steering wheel	[24]					[24]	
Steering column cover	[25]					[25]	
Combination switch	[26]					[26]	
Spiral cable	[27]					[27]	
Cluster lid A	[28]	[4]			[4]	[28]	
Combination meter	[29]	[5]				[29]	
Instrument finisher A					[5]		
Upper ventilator grille	[30]					[30]	
Center speaker	[31]					[31]	
Cluster lid C	[32]		[6]	[6]		[32]	
Cluster lid C lower	[33]			[7]		[33]	
AV control unit	[34]			[8]		[34]	
Cluster lid D	[35]		[7]			[35]	
Front display unit	[36]		[8]			[36]	
instrument panel assembly mounting screws and bolts	[37]					[37]	
Squawker LH harness clip	[38]					[38]	
Instrument panel assembly	[39]					[39]	
Instrument finisher B						[40]	

[]:Number indicates step in removal procedures.

WARNING:

Before servicing, turn ignition switch OFF, disconnect battery negative terminal, and wait 3 minutes or more.

CAUTION:

When removing, always use a remover tool that is made of plastic.

REMOVAL

1. Remove instrument lower cover.
 1. Pull disengaged pawls downward.
 2. Pull back instrument lower cover.
 3. Disconnect harness connectors.

 : Pawl

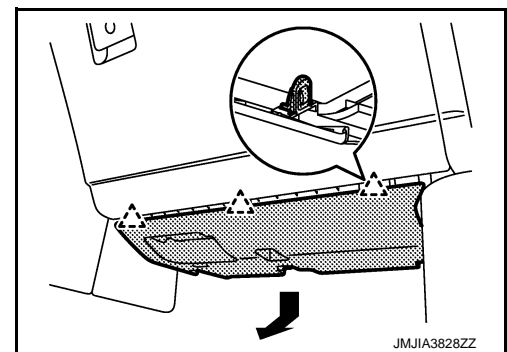

INSTRUMENT PANEL ASSEMBLY

< REMOVAL AND INSTALLATION >

2. Remove glove box assembly.
 1. Remove glove box assembly fixing screws (A).
 2. Open glove box lid.
 3. Remove glove box assembly fixing screws (B).
 4. Pull back glove box assembly.
 5. Disconnect harness connector.

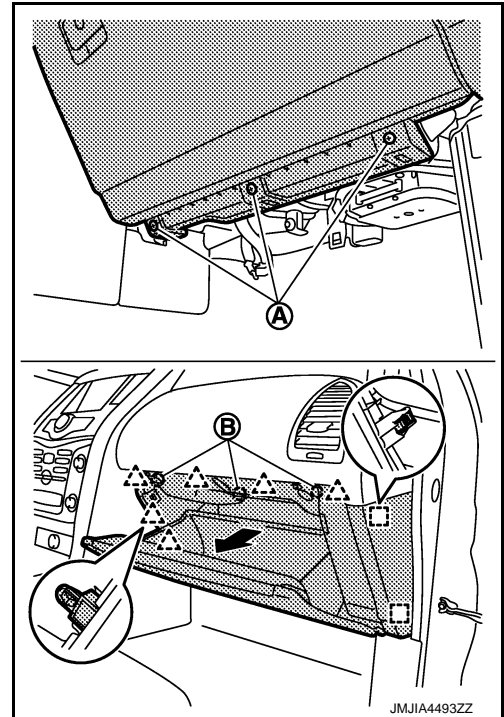
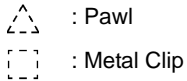

3. Disconnect harness connector (A) of front passenger air bag module.
4. Remove front passenger air bag module mounting bolt (B).

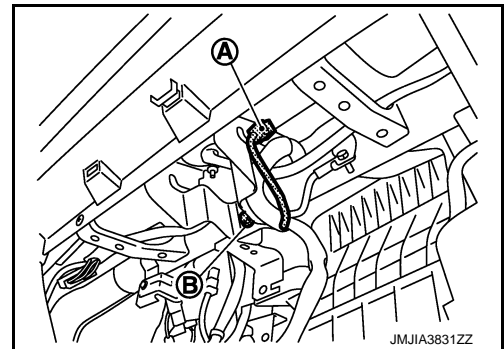

5. Remove selector lever knob. Refer to [TM-176. "Removal and Installation"](#).
6. Remove console finisher assembly.
 1. Put front seat to rearmost position.
 2. Pull console finisher assembly upward to disengage from center console assembly.
 3. Disconnect harness connectors.

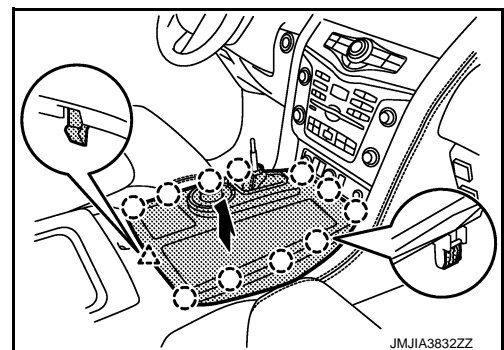
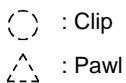

7. Remove instrument center finisher RH.

INSTRUMENT PANEL ASSEMBLY

< REMOVAL AND INSTALLATION >

1. Pull the instrument center finisher RH lower side, and then disengage the fixing clip.

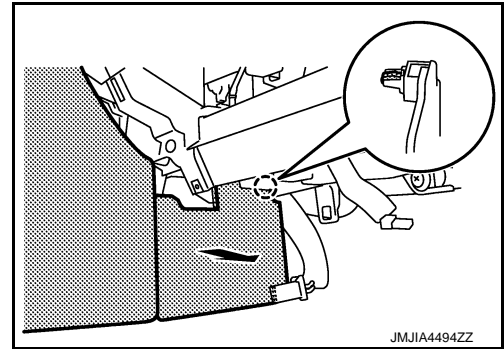
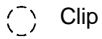

2. Pull back instrument center finisher RH, and then disengage metal clips.
3. Disengage instrument center finisher RH fixing pawl from instrument panel assembly.

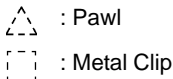
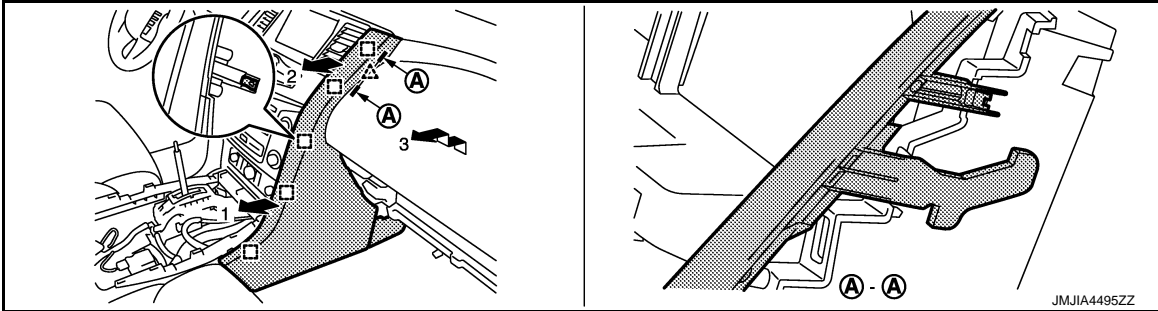

8. Remove front body side welt RH. Refer to [INT-20, "BODY SIDE WELT : Removal and Installation"](#).
9. Remove front pillar garnish RH. Refer to [INT-19, "FRONT PILLAR GARNISH : Removal and Installation"](#).
10. Remove speaker grille RH.
 1. Disengage speaker grille RH fixing pawls with remover tool (A).
 2. Pull up speaker grille RH.

CAUTION:

Apply protective tape (B) on the part to protect it from damage.

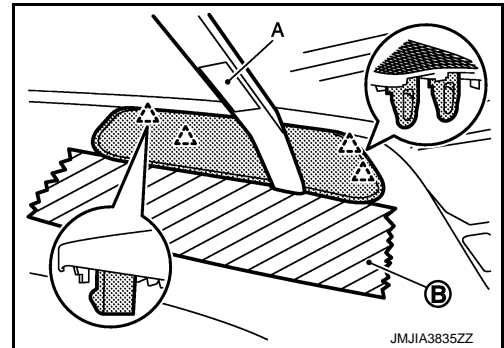
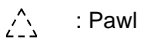

11. Remove squawker RH. Refer to [AV-218, "Removal and Installation"](#).
12. Remove front defroster grille RH. Refer to [VTL-10, "FRONT DEFROSTER GRILLE : Removal and Installation"](#).
13. Remove front defroster grille LH. Refer to [VTL-10, "FRONT DEFROSTER GRILLE : Removal and Installation"](#).
14. Remove instrument center finisher LH.

INSTRUMENT PANEL ASSEMBLY

< REMOVAL AND INSTALLATION >

1. Pull the instrument center finisher LH lower side, and then disengage the fixing clip.

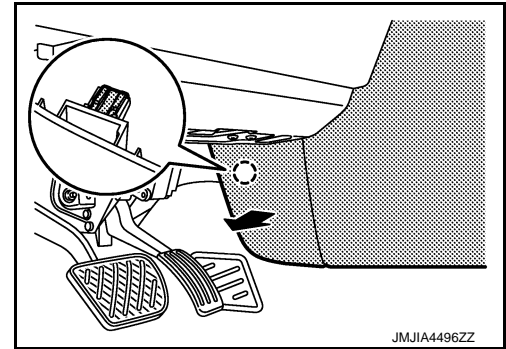
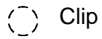

2. Pull back instrument center finisher LH, and then disengage metal clips.
3. Disengage instrument center finisher LH fixing pawl from instrument panel assembly.

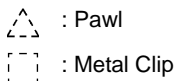
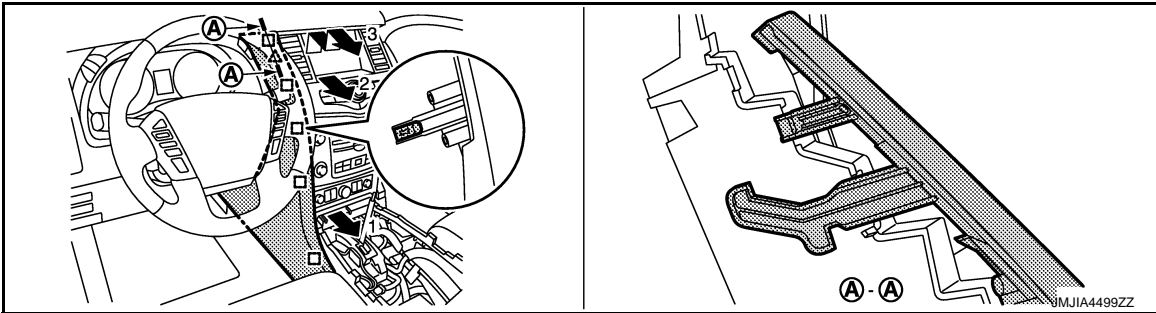

15. Remove console rear finisher.

1. Put front seat to frontmost position.
2. Pull back console rear finisher with remover tool (A).
3. Disconnect harness connectors and harness clips.

CAUTION:

Apply protective tape (B) on the part to protect it from damage.

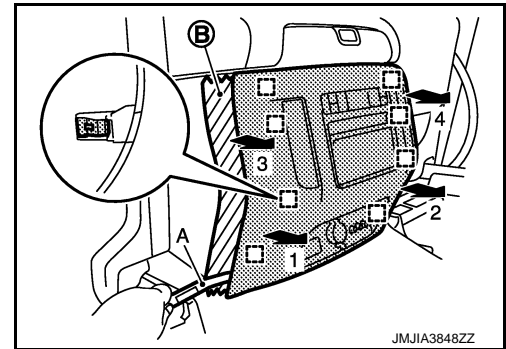

16. Remove center console assembly.

1. Remove centre console assembly rear side fixing screws (A).

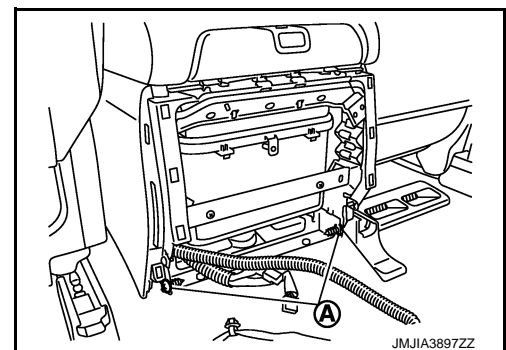

2. Put front seat to rearmost position.

INSTRUMENT PANEL ASSEMBLY

< REMOVAL AND INSTALLATION >

- Remove center console assembly front fixing screws (B).

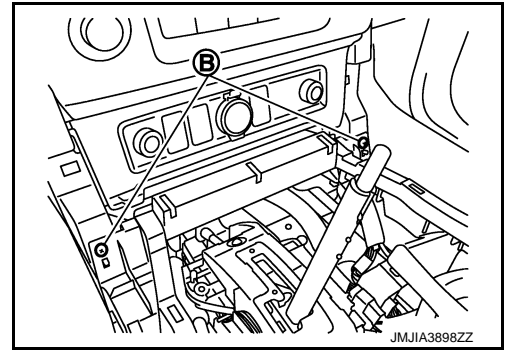

- Lift up center console assembly back side, and then remove center console assembly.

- Remove front body side welt LH. Refer to [INT-20, "BODY SIDE WELT : Removal and Installation"](#).
- Remove front pillar garnish LH. Refer to [INT-19, "FRONT PILLAR GARNISH : Removal and Installation"](#).
- Remove speaker grille LH.

- Disengage speaker grille LH fixing pawls with remover tool (A).
- Pull up speaker grille LH.

CAUTION:

Apply protective tape (B) on the part to protect it from damage.

 : Pawl

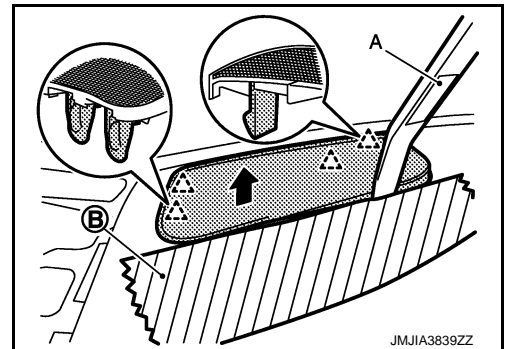

- Remove squawker LH. Refer to [AV-218, "Removal and Installation"](#).

- Remove instrument lower panel LH.

- Remove food opener lever fixing bolts. Refer to [DLK-238, "Removal and Installation"](#)
- Pull back instrument lower panel LH, and then disengage the clips and pawl.
- Disconnect harness connectors and aspirator duct.

 : Clip

 : Pawl

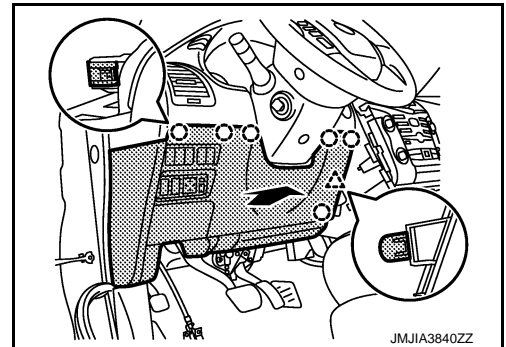

- Disconnect meter control switch harness connector (A).

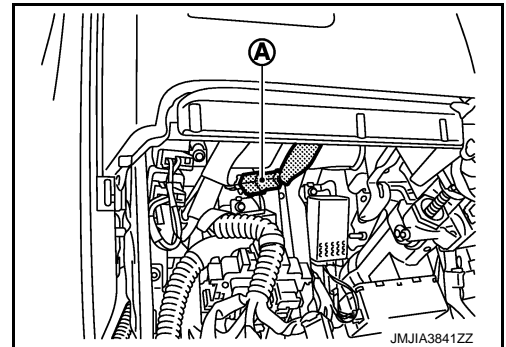

- Remove driver air bag module. Refer to [SR-11, "Removal and Installation"](#).

- Remove steering wheel. Refer to [ST-33, "Removal and Installation"](#).

INSTRUMENT PANEL ASSEMBLY

< REMOVAL AND INSTALLATION >

25. Remove steering column covers.

1. Remove steering column cover fixing screws (A).
2. Pull up steering column upper cover (1), and then disengage steering column upper cover fixing pawls.
3. Remove steering column upper cover.
4. Pull down steering column lower cover (2), and then disconnect ADP steering switch connector (with ADP).
5. Remove steering column lower cover.

 : Pawl

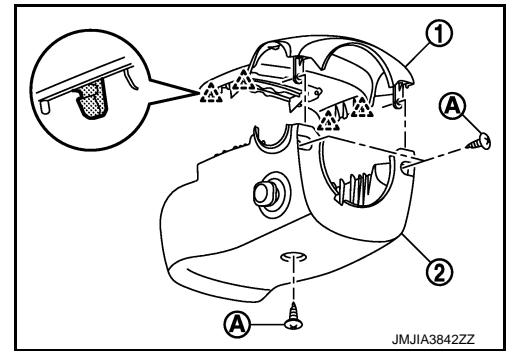



26. Remove combination switch. Refer to [BCS-82, "Removal and Installation"](#).

27. Remove spiral cable. Refer to [SR-14, "Removal and Installation"](#).

28. Remove cluster lid A.

1. Pull back cluster lid A, and then disengage the clips and pawls.
2. Disconnect harness connectors.

 : Clip

 : Pawl

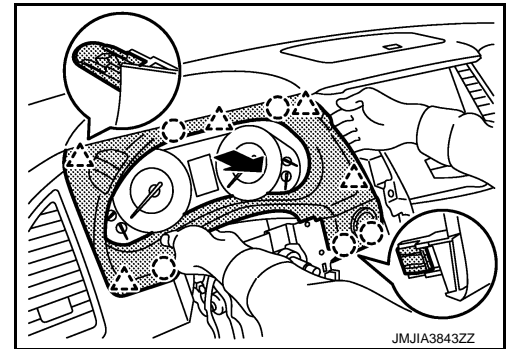

29. Remove combination meter. Refer to [MWI-85, "Removal and Installation"](#).

30. Remove upper ventilator grille.

1. Disengage upper ventilator grille fixing clips and pawls with remover tool (A)
2. Pull toward the arrow direction.

CAUTION:

Apply protective tape (B) on the part to protect it from damage.

 : Clip

 : Pawl

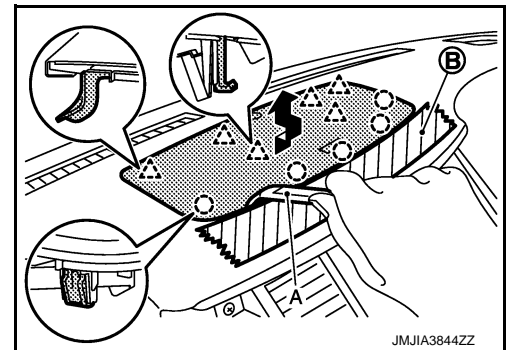

31. Remove center speaker. Refer to [AV-221, "Removal and Installation"](#).

32. Remove cluster lid C.

1. Remove cluster lid C fixing screws (A).
2. Pull back cluster lid C, and then disengage the pawls and metal clips.
3. Disconnect harness connectors.

 : Pawl

 : Metal Clip

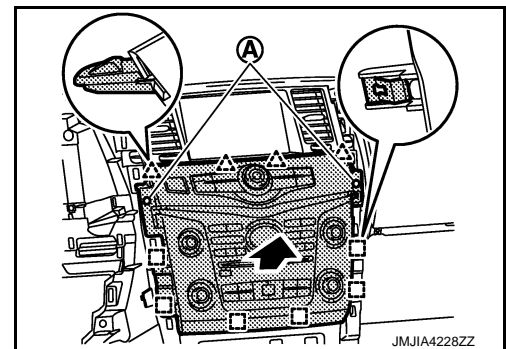

INSTRUMENT PANEL ASSEMBLY

< REMOVAL AND INSTALLATION >

33. Remove cluster lid C lower.

1. Disengage cluster lid C lower fixing metal clips with remover tool (A).
2. Pull back cluster lid C lower, and then disconnect harness connectors.

CAUTION:

Apply protective tape (B) on the part to protect it from damage.

 : Metal Clip

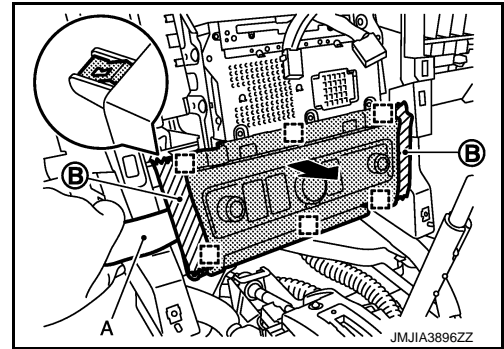

NOTE:

When removing cluster lid C lower without removing center console.

1. Disengage metal clips of lower side of cluster lid C lower using a remover tool (A).
2. Disengage metal clips of upper side of cluster lid C lower using a remover tool.
3. Pull back cluster lid C lower, and then disconnect harness connectors.

 Metal clip

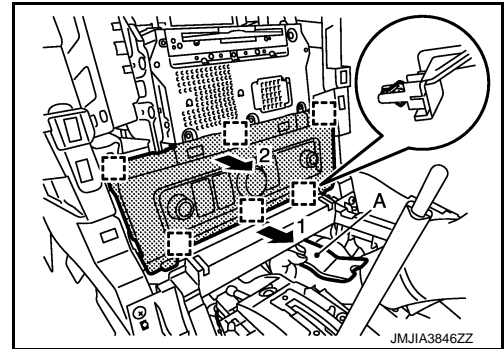

34. Remove AV control unit. Refer to [AV-212. "Removal and Installation"](#).

35. Remove cluster lid D.

1. Remove cluster lid D fixing screw (A).
2. Pull back cluster lid D, and then disengage the pawls and metal clips.

 : Pawl

 : Metal Clip

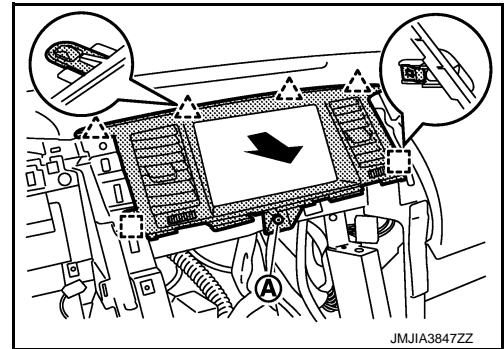

36. Remove front display unit. Refer to [AV-213. "Removal and Installation"](#).

37. Remove instrument panel assembly mounting screws (A) and bolts (B).

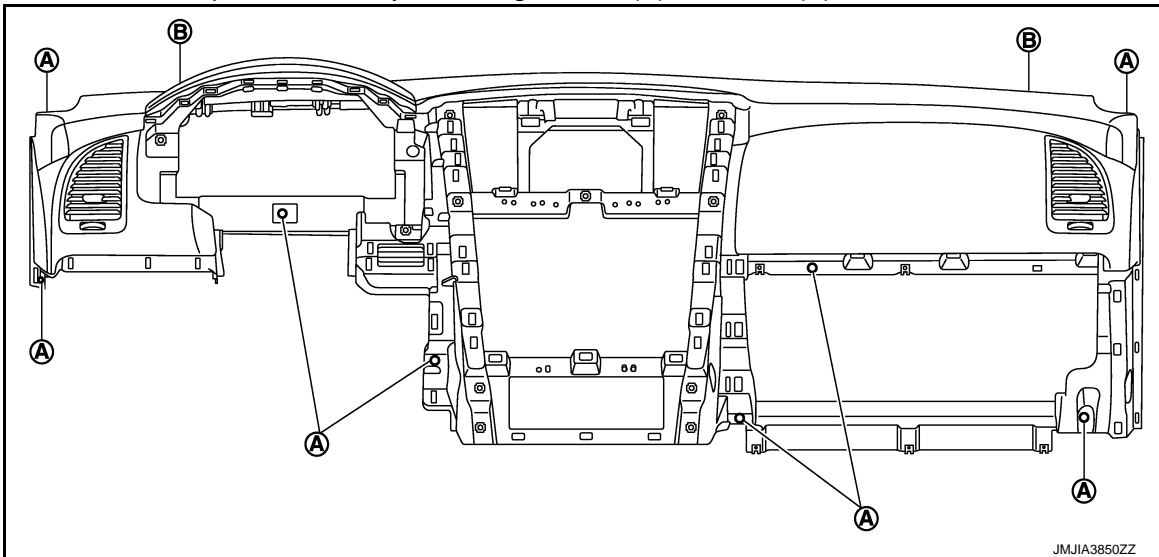

INSTRUMENT PANEL ASSEMBLY

< REMOVAL AND INSTALLATION >

38. Pull back instrument panel assembly, and then remove front squawker LH harness (1) fixing clip (A) from front ventilator duct (2).

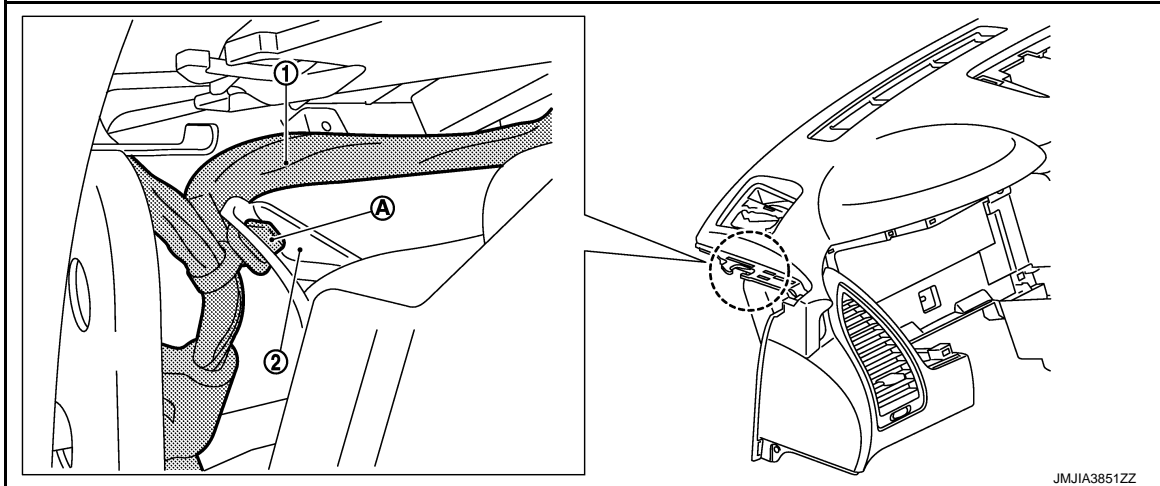

39. Remove instrument panel from passenger door opening portion.

CAUTION:

- Cover tool with a shop cloth to prevent windshield glass from being damaged.
 - When removing instrument panel assembly, 2 workers are required so as to prevent it from dropping.
40. Remove the following parts after removing instrument panel assembly.
- Front passenger air bag module. Refer to [SR-17, "Removal and Installation"](#).
 - Side ventilator grille LH/RH. Refer to [VTL-10, "SIDE VENTILATOR GRILLE : Removal and Installation"](#).
 - Side ventilator duct: Refer to [VTL-10, "SIDE VENTILATOR DUCT : Removal and Installation"](#).
 - Upper ventilator duct: Refer to [VTL-10, "UPPER VENTILATOR DUCT : Removal and Installation"](#).
 - Front defroster nozzle: Refer to [VTL-11, "FRONT DEFROSTER NOZZLE : Removal and Installation"](#).
 - Side defroster nozzle: Refer to [VTL-11, "SIDE DEFROSTER NOZZLE : Removal and Installation"](#).
 - GPS antenna: Refer to [AV-232, "Removal and Installation"](#).
 - Instrument finisher A
 - Instrument finisher B

INSTALLATION

Install in the reverse order of removal.

CENTER CONSOLE ASSEMBLY

< REMOVAL AND INSTALLATION >

CENTER CONSOLE ASSEMBLY

Exploded View

INFOID:000000006113099

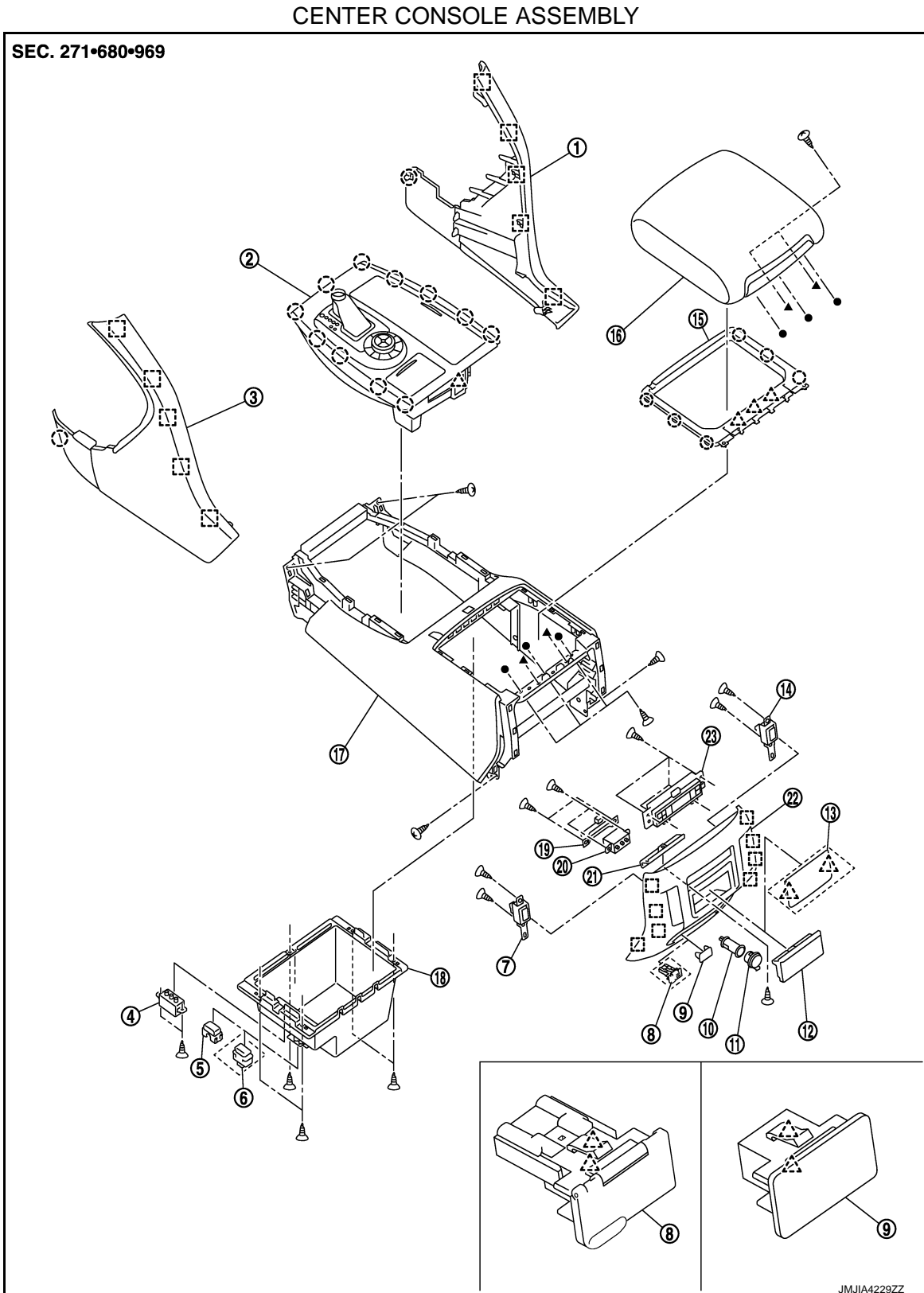

- | | | |
|----------------------------------|------------------------------|----------------------------------|
| 1. Instrument center finisher RH | 2. Console finisher assembly | 3. Instrument center finisher LH |
| 4. Front auxiliary input jacks | 5. Switch hole mask | 6. Main switch |

A
B
C
D
E
F
G
H
I
IP
K
L
M
N
O
P

CENTER CONSOLE ASSEMBLY

< REMOVAL AND INSTALLATION >

- | | | |
|---------------------------------|----------------------------------|-----------------------------|
| 7. Second heated seat switch LH | 8. 120W unit | 9. Mask |
| 10. Inner socket | 11. Socket knob | 12. Console ashtray |
| 13. Mask (without ashtray) | 14. Second heated seat switch RH | 15. Console hinge cover |
| 16. Console lid assembly | 17. Console body assembly | 18. Console box |
| 19. Inside key antenna | 20. Rear auxiliary input jacks | 21. Console ashtray bracket |
| 22. Console rear finisher | 23. Rear A/C control | |

- : Clip
 △ : Pawl
 □ : Metal clip

CONSOLE FINISHER ASSEMBLY

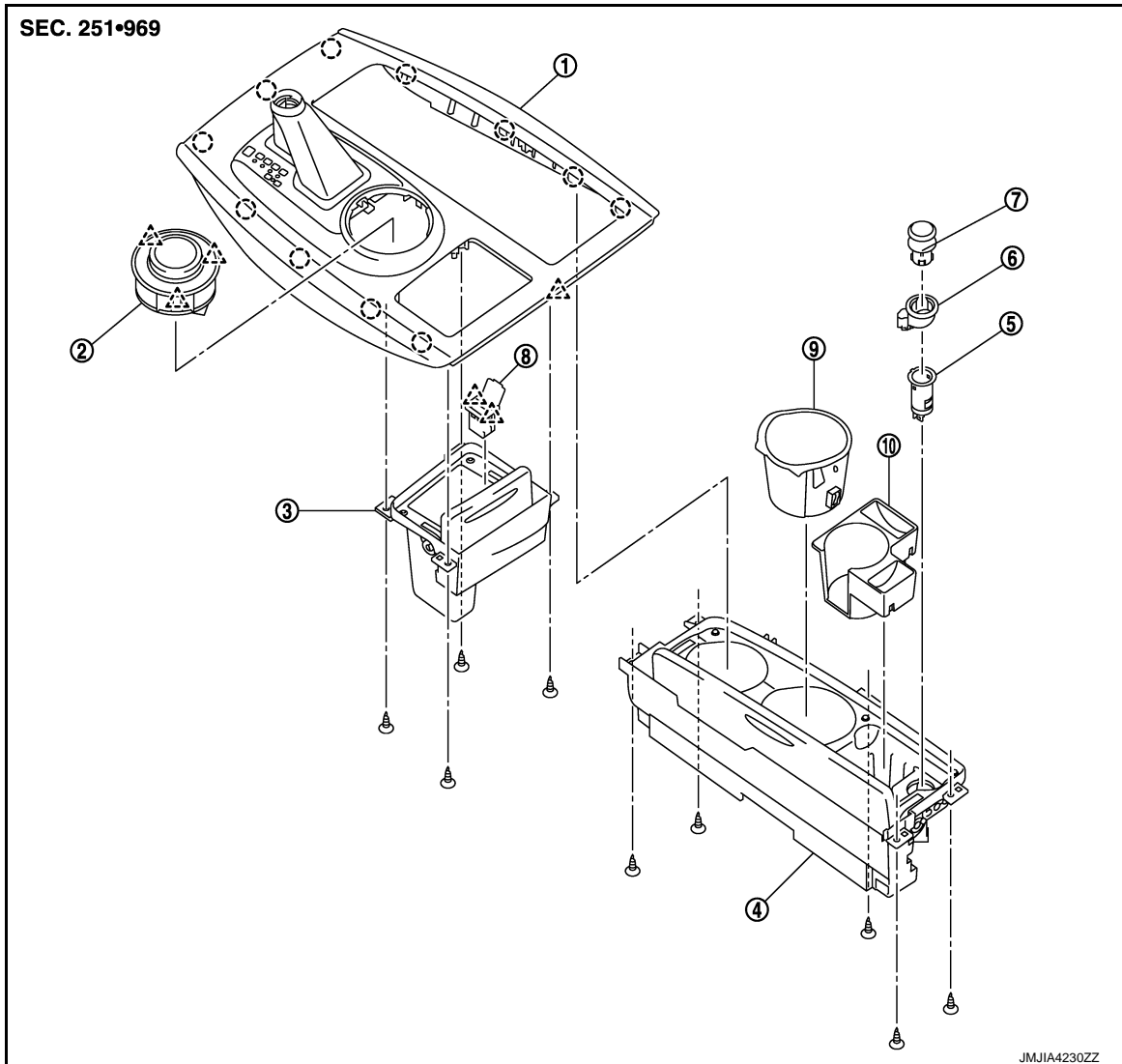

- | | | |
|----------------------------------|--|----------------------------|
| 1. AT control indicator assembly | 2. 4WD: 4WD switch assembly
2WD: SNOW MODE/TOW MODE/
VDC OFF switch assembly | 3. Console pocket assembly |
| 4. Cup holder assembly | 5. Inner socket | 6. Socket ring |
| 7. Socket knob | 8. USB connector | 9. Inner case |
| 10. Coin pocket | | |

- : Clip
 △ : Pawl

CENTER CONSOLE ASSEMBLY

< REMOVAL AND INSTALLATION >

Removal and Installation

INFOID:00000006113100

CAUTION:

When removing, always use a remover tool that is made of plastic.

REMOVAL

1. Remove instrument lower cover.
 1. Pull disengaged pawls downward.
 2. Pull back instrument lower cover.
 3. Disconnect harness connectors.

 : Pawl

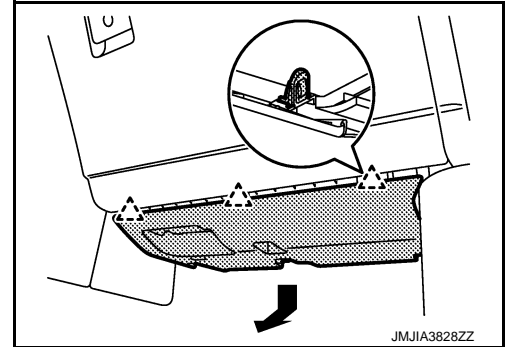

2. Remove selector lever knob. Refer to [TM-176. "Removal and Installation"](#).
3. Remove console finisher assembly.
 1. Put front seat to rearmost position.
 2. Pull console finisher assembly, upward to disengage from center console assembly.
 3. Disconnect harness connectors.

 : Clip

 : Pawl

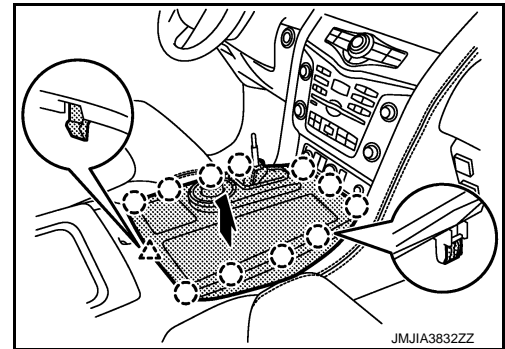

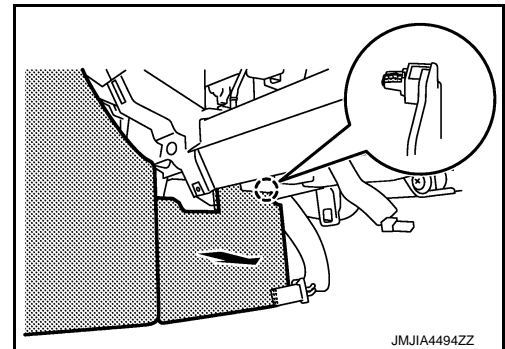

4. Remove instrument center finisher RH.
 1. Pull the instrument center finisher RH lower side, and then disengage the fixing clip.

 Clip

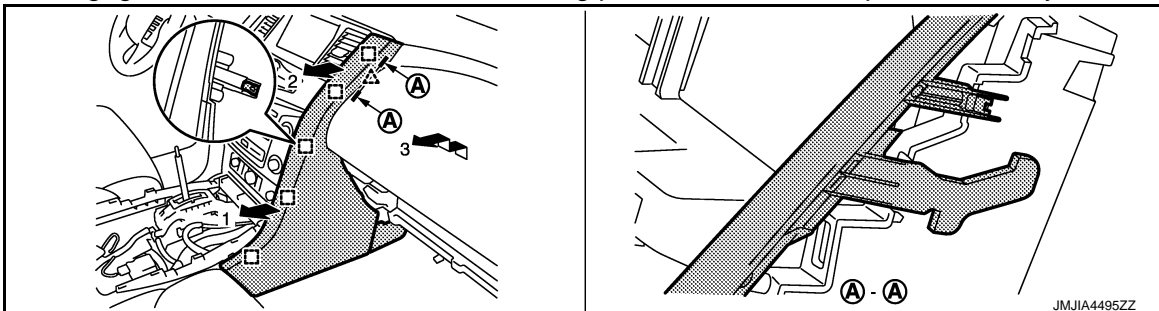

2. Pull back instrument center finisher RH, and then disengage metal clips.
3. Disengage instrument center finisher RH fixing pawl from instrument panel assembly.



 : Pawl

 : Metal Clip

CENTER CONSOLE ASSEMBLY

< REMOVAL AND INSTALLATION >

5. Remove instrument center finisher LH.

1. Pull the instrument center finisher LH lower side, and then disengage the fixing clip.

 Clip

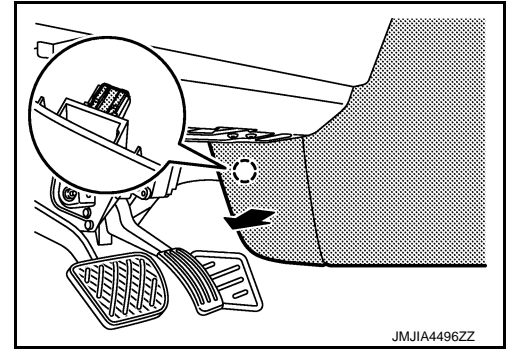

2. Pull back instrument center finisher LH, and then disengage metal clips.
3. Disengage instrument center finisher LH fixing pawl from instrument panel assembly.

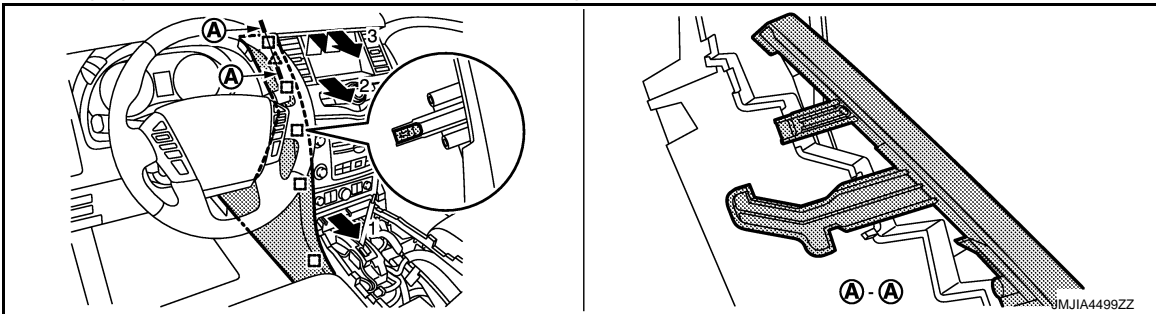

 Pawl

 Metal Clip

6. Remove console rear finisher.

1. Put front seat to frontmost position.
2. Pull back console rear finisher with remover tool (A).
3. Disconnect harness connectors and harness clips.

CAUTION:

Apply protective tape (B) on the part to protect it from damage.

 Metal Clip

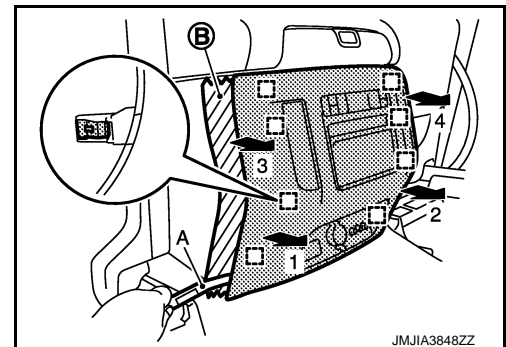

7. Remove center console assembly.

1. Remove center console assembly rear side fixing screws (A).

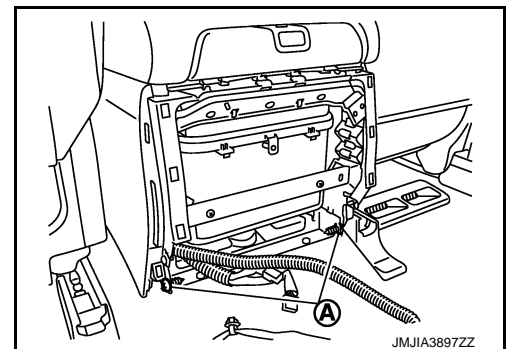

2. Put front seat to rearmost position.

CENTER CONSOLE ASSEMBLY

< REMOVAL AND INSTALLATION >

3. Remove center console assembly front fixing screws (B).

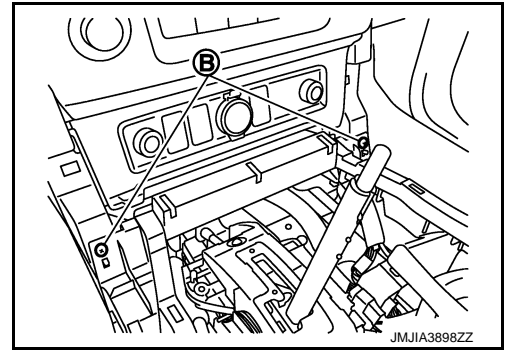

4. Lift up center console assembly back side, and then remove center console assembly.

INSTALLATION

Install in the reverse order of removal.

Disassembly and Assembly

INFOID:000000006113101

CAUTION:

When disassembling, always use a remover tool that is made of plastic.

Disassembly and Assembly of Center Console Assembly

DISASSEMBLY

1. Remove center console assembly. Refer to [IP-25, "Removal and Installation"](#).
2. Remove console mask.
 1. Open console lid.
 2. Remove console mask fixing clips with remover tool (A).
 3. Pull console mask up and back.
 4. Disconnect cool box switch connector (with Cool box).

 : Clip

CAUTION:

Apply protective tape (B) on the part to protect it from damage.

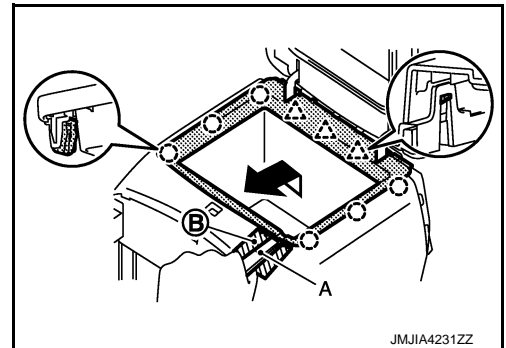

3. Remove console lid assembly mounting screws (A) and (B), and then remove console lid assembly.

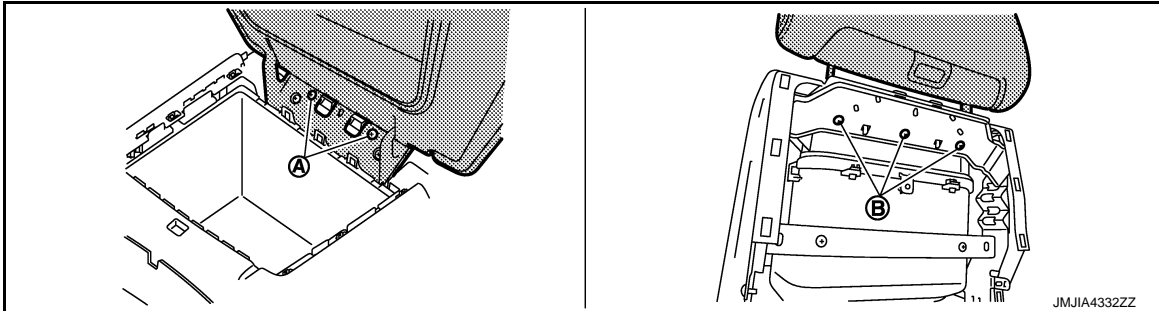

4. Remove console box fixing screws, and then remove console box.

ASSEMBLY

Assemble in the reverse order of disassembly.

Disassembly and Assembly of Console Finisher Assembly

DISASSEMBLY

1. Remove console finisher assembly. Refer to [IP-25, "Removal and Installation"](#).
2. Remove console pocket assembly fixing screws, and then remove console pocket assembly.
3. Remove cup holder assembly fixing screws, and then remove cup holder assembly.

CENTER CONSOLE ASSEMBLY

< REMOVAL AND INSTALLATION >

4. Remove console power socket. Refer to [PWO-11. "CONSOLE POWER SOCKET \(REAR\) : Removal and Installation"](#).
5. Remove 4WD switch assembly (2WD: SNOW MODE/TOW MODE/VDC OFF switch assembly). Refer to [DLN-108. "Removal and Installation"](#).

ASSEMBLY

Assemble in the reverse order of disassembly.

REAR CONSOLE ASSEMBLY

< REMOVAL AND INSTALLATION >



REAR CONSOLE ASSEMBLY

Exploded View

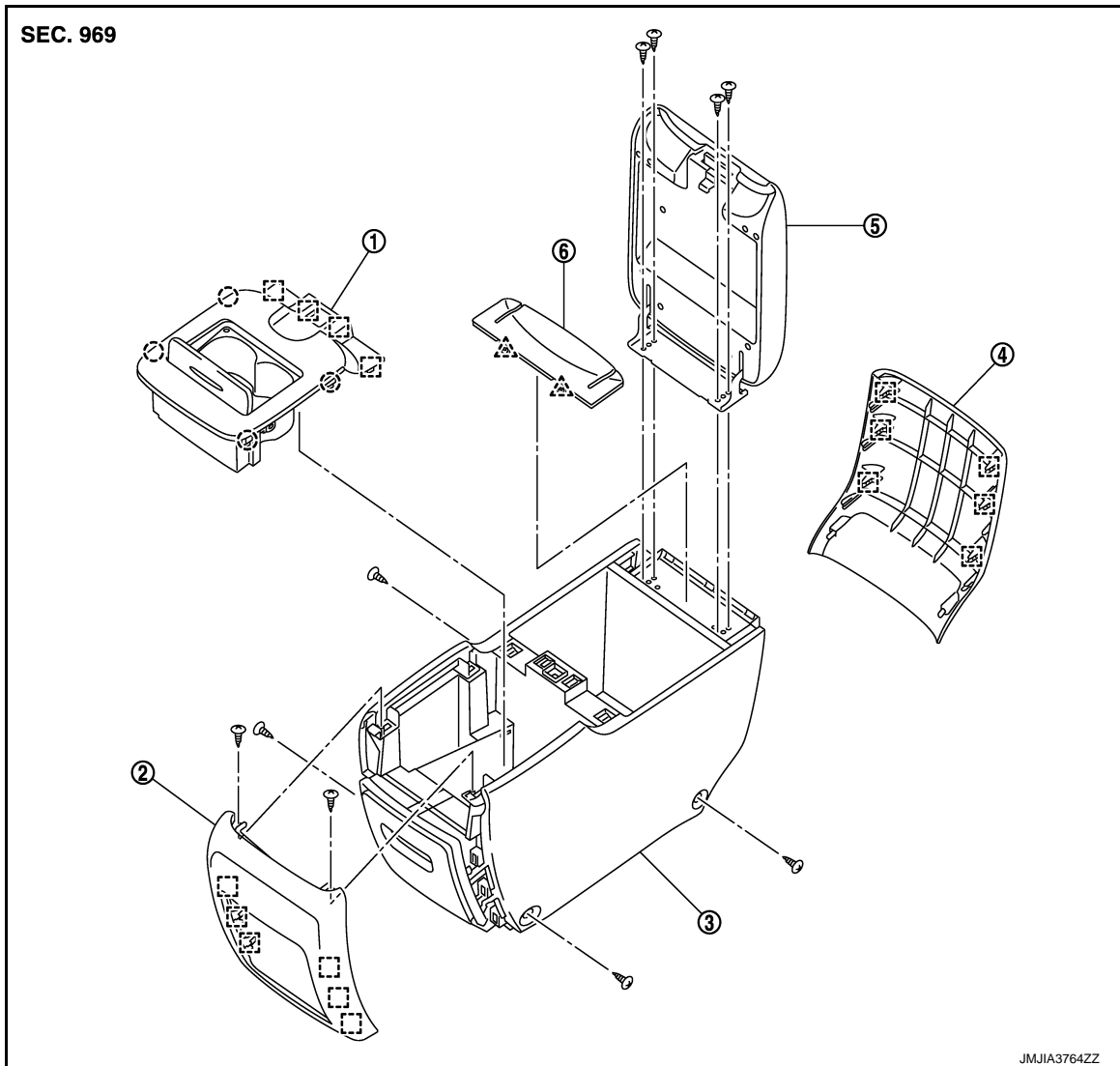
INFOID:000000006113102



- | | | |
|-------------------------------|--------------------------------|-------------------------------|
| 1. Cup holder assembly | 2. Rear console front finisher | 3. Rear console body assembly |
| 4. Rear console rear finisher | 5. Rear console lid assembly | 6. Rear console hinge mask |

-  : Clip
-  : Pawl
-  : Metal clip

Removal and Installation

INFOID:000000006113103

REMOVAL

- Operate rear seat lever or reclining lever to release seat lock assembly lock and to fold 2nd seats forward.
- Remove rear console assembly mounting screws, and then remove rear console assembly.

INSTALLATION

Install in the reverse order of removal.

A
B
C
D
E
F
G
H
I

IP

K
L

M
N

O
P

REAR CONSOLE ASSEMBLY

< REMOVAL AND INSTALLATION >

Disassembly and Assembly

INFOID:000000006113104

CAUTION:

When disassembling, always use a remover tool that is made of plastic.

DISASSEMBLY

1. Remove rear console assembly. Refer to [IP-29, "Removal and Installation"](#).
2. Remove rear console rear finisher.
Pull back rear console rear finisher, and then disengage metal clips.

 : Metal clip

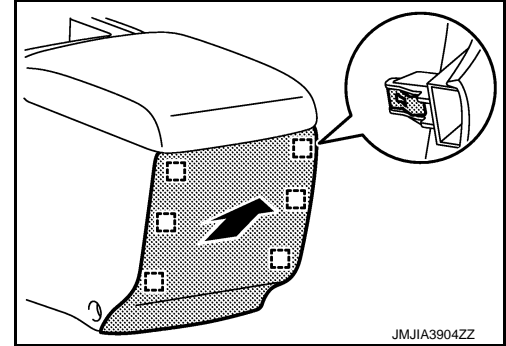

3. Remove rear console mask.
 1. Open the rear console lid assembly.
 2. Remove rear console hinge mask fixing pawls with remover tool (A).
 3. Pull rear console hinge mask up and back.

 : Pawl

CAUTION:

Apply protective tape (B) on the part to protect it from damage.

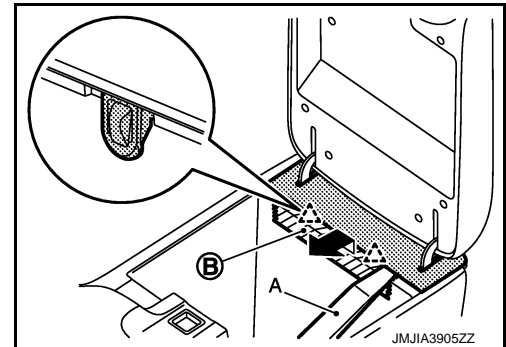

4. Remove console lid assembly mounting screws (A), and then remove console lid assembly.
5. Remove rear cup holder assembly.
 1. Open the rear console lid assembly.
 2. Pull upward to release rear cup holder assembly fixing clips and metal clips from rear console assembly.
 3. Pull rear console mask up and back.

 : Clip

 : Metal clip

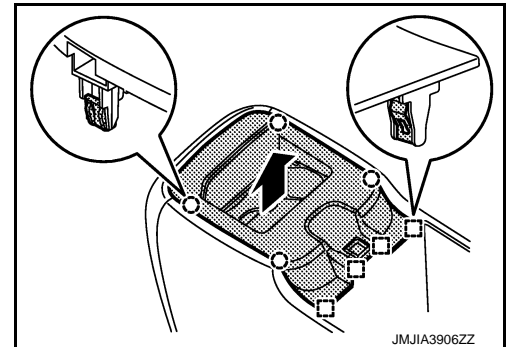

6. Remove rear console front finisher.
 1. Remove screws (A).
 2. Pull rear console front finisher, and then disengage metal clips.

 : Metal clip

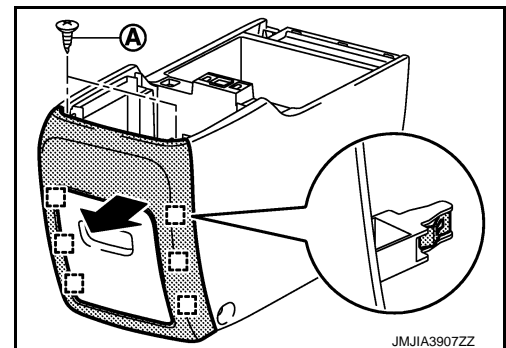

ASSEMBLY

Assemble in the reverse order of disassembly.