

SECTION **MIR**
MIRRORS

A
B
C

CONTENTS

PRECAUTION	3	DOOR MIRROR SYSTEM	11	F
PRECAUTIONS	3	Wiring Diagram	11	
Precaution for Supplemental Restraint System (SRS) "AIR BAG" and "SEAT BELT PRE-TENSIONER"	3	AUTO ANTI-DAZZLING INSIDE MIRROR SYSTEM	19	G
Precaution Necessary for Steering Wheel Rotation after Battery Disconnect	3	Wiring Diagram - INSIDE MIRROR SYSTEM -	19	
PREPARATION	5	BASIC INSPECTION	21	H
PREPARATION	5	DIAGNOSIS AND REPAIR WORKFLOW	21	I
Commercial Service Tools	5	Work Flow	21	
SYSTEM DESCRIPTION	6	DTC/CIRCUIT DIAGNOSIS	22	J
COMPONENT PARTS	6	DOOR MIRROR REMOTE CONTROL SWITCH	22	
DOOR MIRROR	6	OPEN/CLOSE SWITCH	22	K
DOOR MIRROR : Component Parts Location	6	OPEN/CLOSE SWITCH : Component Inspection.....	22	
DOOR MIRROR : Component Description	6	SYMPTOM DIAGNOSIS	23	MIR
INSIDE MIRROR	7	REVERSE INTERLOCK DOOR MIRROR DOES NOT OPERATE	23	
INSIDE MIRROR : Component Description	7	Diagnosis Procedure	23	M
SYSTEM	8	SQUEAK AND RATTLE TROUBLE DIAGNOSES	24	N
DOOR MIRROR SYSTEM	8	Work Flow	24	
DOOR MIRROR SYSTEM : System Diagram	8	Inspection Procedure	26	
DOOR MIRROR SYSTEM : System Description	8	Diagnostic Worksheet	28	O
AUTO ANTI-DAZZLING INSIDE MIRROR SYSTEM	9	REMOVAL AND INSTALLATION	30	P
AUTO ANTI-DAZZLING INSIDE MIRROR SYSTEM : System Description	9	INSIDE MIRROR	30	
ECU DIAGNOSIS INFORMATION	10	Exploded View	30	
DRIVER SEAT CONTROL UNIT, AUTOMATIC DRIVE POSITIONER CONTROL UNIT	10	Removal and Installation	30	
List of ECU Reference	10	OUTSIDE MIRROR	32	
WIRING DIAGRAM	11	Exploded View	32	
		DOOR MIRROR ASSEMBLY	32	

D
E

DOOR MIRROR ASSEMBLY : Removal and Installation	32	DOOR MIRROR COVER : Removal and Installation	36
DOOR MIRROR ASSEMBLY : Disassembly and Assembly	33	SIDE CAMERA FINISHER ASSEMBLY	36
GLASS MIRROR	35	SIDE CAMERA FINISHER ASSEMBLY : Removal and Installation	36
GLASS MIRROR : Removal and Installation	35	DOOR MIRROR REMOTE CONTROL SWITCH	38
DOOR MIRROR COVER	35	Removal and Installation	38

PRECAUTIONS

< PRECAUTION >

PRECAUTION

PRECAUTIONS

Precaution for Supplemental Restraint System (SRS) "AIR BAG" and "SEAT BELT PRE-TENSIONER"

INFOID:000000006257245

The Supplemental Restraint System such as "AIR BAG" and "SEAT BELT PRE-TENSIONER", used along with a front seat belt, helps to reduce the risk or severity of injury to the driver and front passenger for certain types of collision. This system includes seat belt switch inputs and dual stage front air bag modules. The SRS system uses the seat belt switches to determine the front air bag deployment, and may only deploy one front air bag, depending on the severity of a collision and whether the front occupants are belted or unbelted. Information necessary to service the system safely is included in the "SRS AIR BAG" and "SEAT BELT" of this Service Manual.

WARNING:

- To avoid rendering the SRS inoperative, which could increase the risk of personal injury or death in the event of a collision that would result in air bag inflation, all maintenance must be performed by an authorized NISSAN/INFINITI dealer.
- Improper maintenance, including incorrect removal and installation of the SRS, can lead to personal injury caused by unintentional activation of the system. For removal of Spiral Cable and Air Bag Module, see the "SRS AIR BAG".
- Do not use electrical test equipment on any circuit related to the SRS unless instructed to in this Service Manual. SRS wiring harnesses can be identified by yellow and/or orange harnesses or harness connectors.

PRECAUTIONS WHEN USING POWER TOOLS (AIR OR ELECTRIC) AND HAMMERS

WARNING:

- When working near the Air Bag Diagnosis Sensor Unit or other Air Bag System sensors with the ignition ON or engine running, DO NOT use air or electric power tools or strike near the sensor(s) with a hammer. Heavy vibration could activate the sensor(s) and deploy the air bag(s), possibly causing serious injury.
- When using air or electric power tools or hammers, always switch the ignition OFF, disconnect the battery, and wait at least 3 minutes before performing any service.

Precaution Necessary for Steering Wheel Rotation after Battery Disconnect

INFOID:000000006257246

NOTE:

- Before removing and installing any control units, first turn the push-button ignition switch to the LOCK position, then disconnect both battery cables.
- After finishing work, confirm that all control unit connectors are connected properly, then re-connect both battery cables.
- Always use CONSULT-III to perform self-diagnosis as a part of each function inspection after finishing work. If a DTC is detected, perform trouble diagnosis according to self-diagnosis results.

For vehicle with steering lock unit, if the battery is disconnected or discharged, the steering wheel will lock and cannot be turned.

If turning the steering wheel is required with the battery disconnected or discharged, follow the operation procedure below before starting the repair operation.

OPERATION PROCEDURE

1. Connect both battery cables.

NOTE:

Supply power using jumper cables if battery is discharged.

2. Turn the push-button ignition switch to ACC position.
(At this time, the steering lock will be released.)
3. Disconnect both battery cables. The steering lock will remain released with both battery cables disconnected and the steering wheel can be turned.
4. Perform the necessary repair operation.

A
B
C
D
E
F
G
H
I
J
K

MIR

M
N
O
P

PRECAUTIONS

< PRECAUTION >

5. When the repair work is completed, re-connect both battery cables. With the brake pedal released, turn the push-button ignition switch from ACC position to ON position, then to LOCK position. (The steering wheel will lock when the push-button ignition switch is turned to LOCK position.)
6. Perform self-diagnosis check of all control units using CONSULT-III.

PREPARATION

< PREPARATION >

PREPARATION

PREPARATION

Commercial Service Tools

INFOID:000000006257218

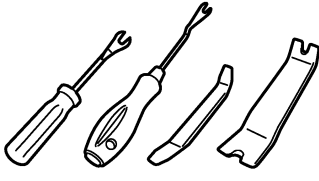
Tool name	Description
Remover tools  JMKIA3050ZZ	Removes the clips, pawls and metal clips

A
B
C
D
E
F
G
H
I
J
K
M
N
O
P

MIR

COMPONENT PARTS

< SYSTEM DESCRIPTION >

SYSTEM DESCRIPTION

COMPONENT PARTS

DOOR MIRROR

DOOR MIRROR : Component Parts Location

INFOID:000000006257219

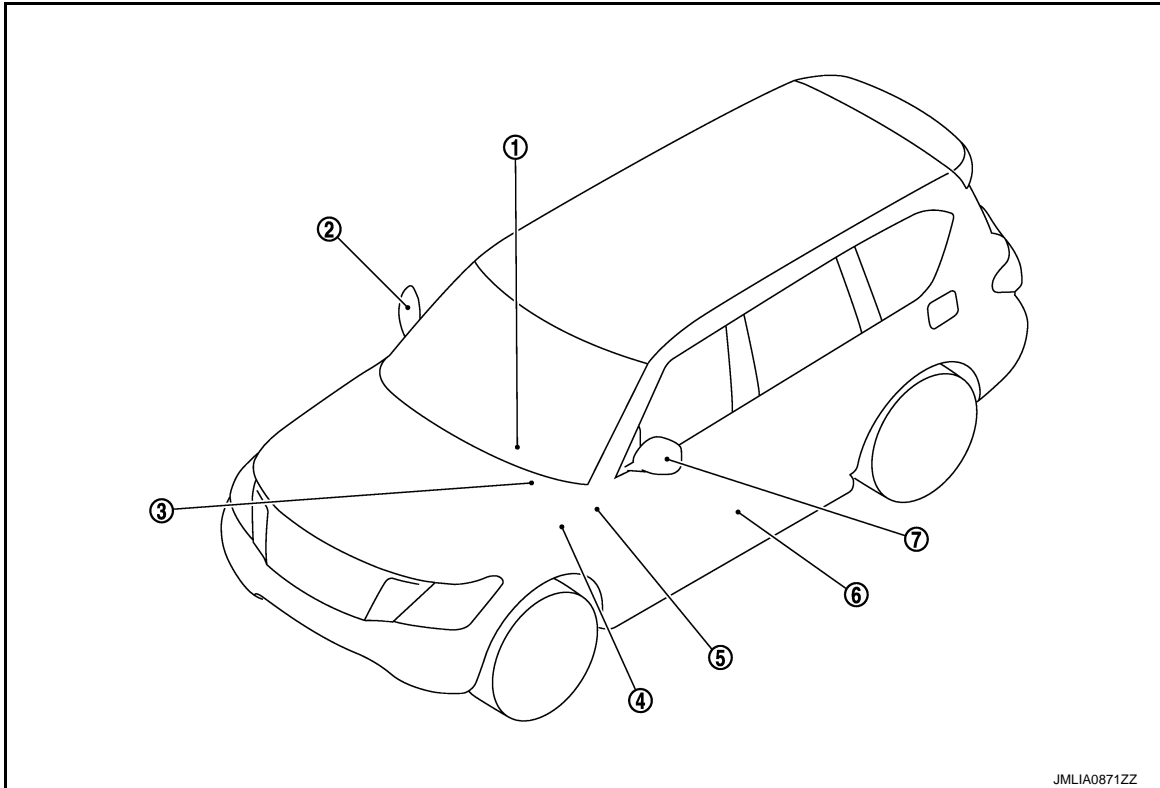

JMLIA0871ZZ

- | | | |
|--|--------------------------------------|--|
| 1. TCM
Refer to TM-10, "A/T CONTROL SYSTEM : Component Parts Location" | 2. Door mirror (passenger side) | 3. BCM
Refer to BCS-4, "BODY CONTROL SYSTEM : Component Parts Location" |
| 4. Automatic drive positioner control unit
Refer to ADP-6, "Component Parts Location" | 5. Door mirror remote control switch | 6. Driver seat control unit
Refer to ADP-6, "Component Parts Location" |
| 7. Door mirror (driver side) | | |

DOOR MIRROR : Component Description

INFOID:000000006257220

Component parts		Description
Automatic drive positioner control unit		Door mirror is supplied with power after receiving the input of mirror switch and changeover switch.
Door mirror remote control switch	Mirror switch	It transmits mirror face adjust operation to automatic drive positioner control unit.
	Changeover switch	It transmits the LH/RH control of door mirror that supplies power to automatic drive positioner control unit.
	Open/close switch	Power is supplied to folding mirror from door mirror remote control switch when operating switch.
Door mirror		It makes mirror face operate from side to side and up and down via integrated motor.

COMPONENT PARTS

< SYSTEM DESCRIPTION >

Component parts	Description
BCM	The ignition switch signal (ACC/ON) is transmitted to driver seat control unit via CAN communication.
Driver seat control unit	The ignition switch signal (ACC/ON) is transmitted to automatic drive positioner control unit via UART communication.
TCM	The A/T shift position signal is transmitted to driver seat control unit via CAN communication.

INSIDE MIRROR

INSIDE MIRROR : Component Description

INFOID:000000006257221

Component	Function
Auto anti-dazzling inside mirror	It automatically changes the light transmittance according to the brightness of the light from the headlight of the vehicle behind.

A
B
C
D
E
F
G
H
I
J
K
M
N
O
P

MIR

SYSTEM

< SYSTEM DESCRIPTION >

SYSTEM

DOOR MIRROR SYSTEM

DOOR MIRROR SYSTEM : System Diagram

INFOID:000000006257222

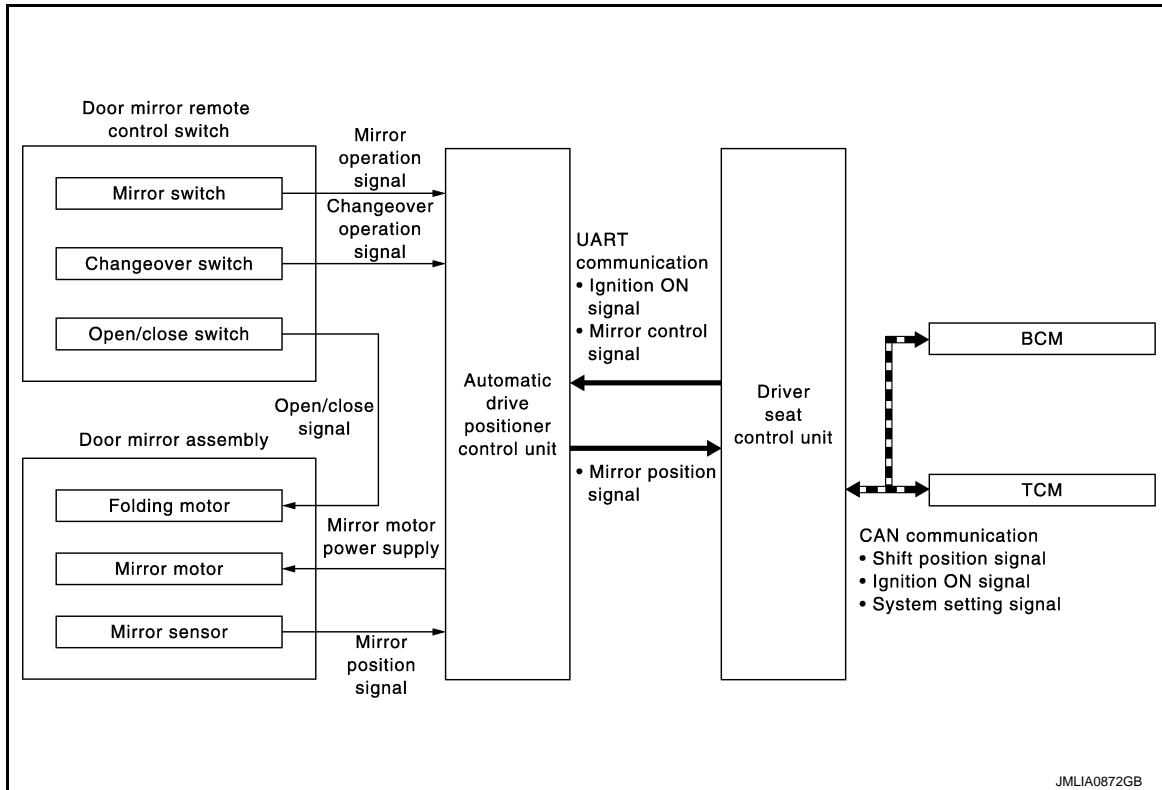

DOOR MIRROR SYSTEM : System Description

INFOID:000000006257223

MANUAL FUNCTION

Description

- Automatic drive positioner control unit controls door mirror.
- Automatic drive positioner control unit inputs changeover switch signal and perform the LH/RH control of door mirror motor supplying electric power when changeover switch is operated.
- Automatic drive positioner control unit inputs mirror switch signal and supplies electric power to door mirror.
- The ignition switch signal (ACC/ON) is transmitted from BCM to driver seat control unit via CAN communication and from driver seat control unit to automatic drive positioner control unit via UART communication.

Operation Conditions

If the following conditions are not satisfied, operation is not performed.

- Ignition switch: ON or ACC
- Changeover switch: Select either left or right

REVERSE INTERLOCK DOOR MIRROR SYSTEM

Description

- Select either of the door mirror faces by changeover switch, and then set mirror face downward.
- When ignition switch is ON position and A/T shift selector is in R position, TCM sends the R signal to driver seat control unit.
- The R signal is transmitted to automatic drive positioner control unit from driver seat control unit via UART communication.
- When the R signal is detected, automatic drive positioner control unit activated mirror motor.

Operation Conditions

If the following conditions are not satisfied, operation is not performed.

- Ignition switch: ON

SYSTEM

< SYSTEM DESCRIPTION >

- Changeover switch: Select either left or right
- A/T shift selector: R position

NOTE:

During the reverse interlock door mirror system, if all of the above conditions are not satisfied, mirror face returns to original angle.

AUTO ANTI-DAZZLING INSIDE MIRROR SYSTEM

AUTO ANTI-DAZZLING INSIDE MIRROR SYSTEM : System Description INFOID:000000006257224

The sensor built in inside mirror detects the brightness of headlight of the vehicle behind and automatically changes the light transmission to decrease the brightness.

A
B
C
D
E
F
G
H
I
J
K
M
N
O
P

MIR

DRIVER SEAT CONTROL UNIT, AUTOMATIC DRIVE POSITIONER CONTROL UNIT

< ECU DIAGNOSIS INFORMATION >

ECU DIAGNOSIS INFORMATION

DRIVER SEAT CONTROL UNIT, AUTOMATIC DRIVE POSITIONER CONTROL UNIT

List of ECU Reference

INFOID:000000006257225

ECU	Reference
DRIVER SEAT CONTROL UNIT	ADP-25, "Reference Value"
	ADP-30, "Fail Safe"
	ADP-31, "DTC Index"
AUTOMATIC DRIVE POSITIONER CONTROL UNIT	ADP-32, "Reference Value"

DOOR MIRROR SYSTEM

< WIRING DIAGRAM >

WIRING DIAGRAM

DOOR MIRROR SYSTEM

Wiring Diagram

INFOID:000000006257226

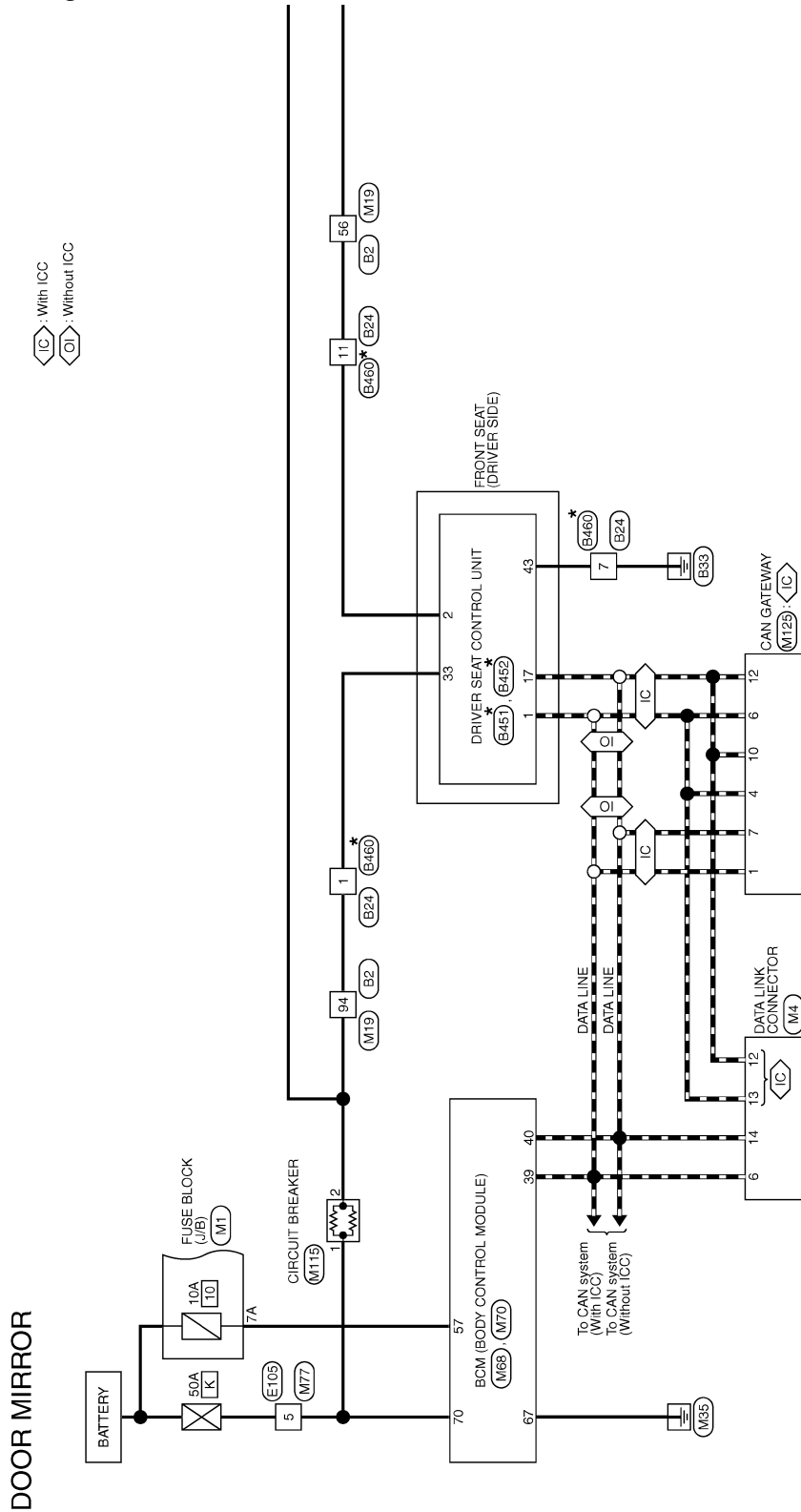

* : This connector is not shown in "Harness Layout".

2010/05/13

JCLWM5426GB

A
B
C
D
E
F
G
H
I
J
K
L
M
N
O
P

MIR

DOOR MIRROR SYSTEM

< WIRING DIAGRAM >

DOOR MIRROR

Connector No.	B2
Connector Name	WIRE TO WIRE
Connector Type	TH80MW-CS (E-TM4)

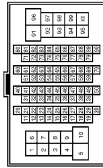

Terminal No.	Color of Wire	Signal Name [Specification]
2	L	-
3	BR	-
5	R/W	-
6	L	-
7	V	-
9	G	-
11	W/B	-
12	BR	-
13	G/R	-
14	B/Y	-
15	W/R	-
16	GR/R	-
18	G/W	-
19	V	-
20	W/G	-
21	B/W	-
22	V	-
23	SHIELD	-
24	G	-
25	O	-
26	Y	-
27	L/O	-
28	Y/R	-
29	L	-
30	R	-
31	G/Y	-
32	B/SB	-
33	LG/R	-
34	BR/W	-
35	GR/R	-
36	SB	-
37	LG	-
38	L	-
39	P	-
40	W/G	-
42	G/R	-
43	V/W	-
44	LG/B	-

Connector No.	B24
Connector Name	WIRE TO WIRE
Connector Type	HS12PW-CS



Terminal No.	Color of Wire	Signal Name [Specification]
1	W/R	-
2	Y/G	-
3	P/L	-
4	GR/R	-
5	LG/B	-
7	B	-
8	G/O	-
9	L	-
10	R/B	-
11	LG/R	-
12	P	-
13	L	-
14	V/W	-
15	BR	-

Connector No.	B431
Connector Name	DRIVER SEAT CONTROL UNIT
Connector Type	TH82PW-RH

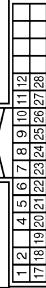

Terminal No.	Color of Wire	Signal Name [Specification]
1	R/Y	CAN-H
2	R	UART (TX/RX)
4	R/L	PULSE (RECLINER)
5	R/B	TELESCOPIC SENSOR
6	R/W	ADDRESS 2
7	R/G	IND-2
8	SB	SLIDE SW (BACKWARD)
9	L	RECLINER SW (BACKWARD)

10	L/B	FRONT LIFTER SW (DOWNWARD)
11	L/W	REAR LIFTER SW (DOWNWARD)
12	L/R	SENSOR POWER SUPPLY
17	V	-
18	B/W	CAN-L
19	B/R	PULSE (SLIDE)
20	B/L	PULSE (FRONT LIFTER)
21	W/B	PULSE (REAR LIFTER)
22	W/L	TILT SENSOR
23	W/R	ADDRESS 1
24	V/W	IND-1
25	Y/W	SLIDE SW (FORWARD)
26	Y/B	RECLINER SW (FORWARD)
25	Y/R	FRONT LIFTER SW (UPWARD)
27	Y/L	REAR LIFTER SW (UPWARD)
28	G	SET SW

Connector No.	B462
Connector Name	DRIVER SEAT CONTROL UNIT
Connector Type	HS12PW-CS

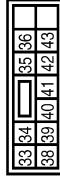

Terminal No.	Color of Wire	Signal Name [Specification]
33	R	BAT
34	B	SLIDE MOTOR (BACKWARD)
35	G	RECLINER MOTOR (FORWARD)
36	L	FRONT LIFTER MOTOR (DOWNWARD)
38	GR	SLIDE MOTOR (FORWARD)
39	Y	RECLINER MOTOR (BACKWARD)
40	W	FRONT LIFTER MOTOR (UPWARD)
41	V	REAR LIFTER MOTOR (UPWARD)
42	P/B	REAR LIFTER MOTOR (DOWNWARD)
43	LG	GND

A
B
C
D
E
F
G
H
I
J
K
L
M
N
O
P

MIR

DOOR MIRROR SYSTEM

< WIRING DIAGRAM >

DOOR MIRROR

Connector No.	B460
Connector Name	WIRE TO WIRE
Connector Type	TH16MW-CS



1	2	3	4	5	6	7		
8	9	10	11	12	13	14	15	16

Terminal No.	Color of Wire	Signal Name [Specification]
1	R	-
2	R/G	-
3	R/W	-
4	W/R	-
5	W/L	-
7	LG	-
8	W/B	-
9	R/B	-
10	R	-
11	R	-
12	V	-
13	R/Y	-
14	G	-
15	-	-

Connector No.	D1
Connector Name	WIRE TO WIRE
Connector Type	TH40PW-CS15



1	2	3	4	5	6	7	8	9	10	11	12	13	14	15	16	17	18	19	20	21	22	23	24	25	26	27	28	29	30	31	32	33	34	35	36	37	38	39	40	41	42	43	44	45	46	47	48	49	50	51	52	53	54	55	56	57	58	59	60	61	62	63	64	65	66	67	68	69	70	71	72	73	74	75	76	77	78	79	80	81	82	83	84	85	86	87	88	89	90	91	92	93	94	95	96	97	98	99	100
---	---	---	---	---	---	---	---	---	----	----	----	----	----	----	----	----	----	----	----	----	----	----	----	----	----	----	----	----	----	----	----	----	----	----	----	----	----	----	----	----	----	----	----	----	----	----	----	----	----	----	----	----	----	----	----	----	----	----	----	----	----	----	----	----	----	----	----	----	----	----	----	----	----	----	----	----	----	----	----	----	----	----	----	----	----	----	----	----	----	----	----	----	----	----	----	----	----	----	-----

Terminal No.	Color of Wire	Signal Name [Specification]
1	V	-
2	W	-
3	V	-
4	Y	-
5	LG/R	-
6	BR/W	-
8	V	-
9	G	-

10	L	-
11	L/O	-
13	Y	-
14	R	-
15	B	-
16	B	-
17	R	-
18	B	-
19	BR/Y	-
20	P	-
22	V	-
23	P/B	-
25	BR/W	-
26	W/R	-
28	W/G	-
33	V/W	-
36	W/B	-
37	BR/Y	-
38	SB	-
39	W/L	-
40	L/W	-
41	V/G	-
42	P/L	-
43	LG	-
44	SHIELD	-
45	G	-
46	W	-
47	O	-
48	G/W	-
49	Y	-
50	L/Y	-
51	GR/R	-
52	LG/B	-
53	Y	-
54	B	-
55	R	-

Connector No.	D3
Connector Name	DOOR MIRROR (DRIVER SIDE)
Connector Type	TH2MMV-NH



1	2	3	4	5	6	7	8	9	10	11	12	13	14	15	16	17	18	19	20	21	22	23	24	25	26	27	28	29	30	31	32	33	34	35	36	37	38	39	40	41	42	43	44	45	46	47	48	49	50	51	52	53	54	55	56	57	58	59	60	61	62	63	64	65	66	67	68	69	70	71	72	73	74	75	76	77	78	79	80	81	82	83	84	85	86	87	88	89	90	91	92	93	94	95	96	97	98	99	100
---	---	---	---	---	---	---	---	---	----	----	----	----	----	----	----	----	----	----	----	----	----	----	----	----	----	----	----	----	----	----	----	----	----	----	----	----	----	----	----	----	----	----	----	----	----	----	----	----	----	----	----	----	----	----	----	----	----	----	----	----	----	----	----	----	----	----	----	----	----	----	----	----	----	----	----	----	----	----	----	----	----	----	----	----	----	----	----	----	----	----	----	----	----	----	----	----	----	----	-----

Terminal No.	Color of Wire	Signal Name [Specification]
2	BR/W	-
3	W	SIDE CAMERA LH COMM

5	Y	SIDE CAMERA LH IMAGE SIGNAL
6	R	SIDE CAMERA LH POWER SUPPLY
7	L	-
8	O	-
9	W/B	-
10	SB	-
11	BR/Y	-
12	L/W	-
14	P	-
17	G	SIDE CAMERA LH IMAGE GND
18	B	SIDE CAMERA LH GND
19	B	-
20	G	-
21	L/Y	-
22	G/W	-
23	W/L	-
24	Y	-

Connector No.	D21
Connector Name	WIRE TO WIRE
Connector Type	TH40PW-CS15



1	2	3	4	5	6	7	8	9	10	11	12	13	14	15	16	17	18	19	20	21	22	23	24	25	26	27	28	29	30	31	32	33	34	35	36	37	38	39	40	41	42	43	44	45	46	47	48	49	50	51	52	53	54	55	56	57	58	59	60	61	62	63	64	65	66	67	68	69	70	71	72	73	74	75	76	77	78	79	80	81	82	83	84	85	86	87	88	89	90	91	92	93	94	95	96	97	98	99	100
---	---	---	---	---	---	---	---	---	----	----	----	----	----	----	----	----	----	----	----	----	----	----	----	----	----	----	----	----	----	----	----	----	----	----	----	----	----	----	----	----	----	----	----	----	----	----	----	----	----	----	----	----	----	----	----	----	----	----	----	----	----	----	----	----	----	----	----	----	----	----	----	----	----	----	----	----	----	----	----	----	----	----	----	----	----	----	----	----	----	----	----	----	----	----	----	----	----	----	-----

Terminal No.	Color of Wire	Signal Name [Specification]
1	G	-
2	W	-
3	V	-
8	P/L	-
8	L/R	-
8	L/W	-
9	G/Y	-
10	L	-
11	L/O	-
13	L	-
14	R	-
15	B	-
18	B/W	-
18	R	-
20	P	-
22	Y/R	-
23	LG/B	-
25	R/W	-
26	W/R	-

36	G/O	-
37	Y/B	-
38	V	-
39	W/L	-
40	L/O	-
44	SHIELD	-
45	Y	-
46	W	-
47	LG	-
48	L/R	-
49	Y	-
50	R/B	-
52	LG	-
53	G	-
54	B	-
55	R	-

Connector No.	D23
Connector Name	DOOR MIRROR (PASSENGER SIDE)
Connector Type	TH2MMV-NH



1	2	3	4	5	6	7	8	9	10	11	12	13	14	15	16	17	18	19	20	21	22	23	24	25	26	27	28	29	30	31	32	33	34	35	36	37	38	39	40	41	42	43	44	45	46	47	48	49	50	51	52	53	54	55	56	57	58	59	60	61	62	63	64	65	66	67	68	69	70	71	72	73	74	75	76	77	78	79	80	81	82	83	84	85	86	87	88	89	90	91	92	93	94	95	96	97	98	99	100
---	---	---	---	---	---	---	---	---	----	----	----	----	----	----	----	----	----	----	----	----	----	----	----	----	----	----	----	----	----	----	----	----	----	----	----	----	----	----	----	----	----	----	----	----	----	----	----	----	----	----	----	----	----	----	----	----	----	----	----	----	----	----	----	----	----	----	----	----	----	----	----	----	----	----	----	----	----	----	----	----	----	----	----	----	----	----	----	----	----	----	----	----	----	----	----	----	----	----	-----

Terminal No.	Color of Wire	Signal Name [Specification]
2	R/W	-
3	W	SIDE CAMERA LH COMM
4	LG	SIDE CAMERA LH IMAGE SIGNAL
5	Y	SIDE CAMERA LH POWER SUPPLY
8	R	-
7	L	-
8	LG	-
9	G/O	-
10	V	-
11	Y/B	-
12	L/O	-
14	P	-
17	G	SIDE CAMERA LH IMAGE GND
18	B	SIDE CAMERA LH GND
19	B	-
20	G/Y	-
21	R/B	-
22	L/R	-
23	W/L	-
24	Y	-

JCLWM5429GB

DOOR MIRROR SYSTEM

< WIRING DIAGRAM >

DOOR MIRROR

Connector No.	E105
Connector Name	WIRE TO WIRE
Connector Type	TH80MW-CS (E-TM4)



Terminal No.	Color of Wire	Signal Name [Specification]
1	L	
2	L/W	
3	R/B	
4	L	
5	Y	
7	W/G	
8	P/B	
9	W/B	
10	L	
11	L	
12	P	
13	P/B	
14	BR	
15	L/B	
16	SB	
17	P	
18	BR	
19	Y/G	
20	BR/Y	
21	Y/V	
22	L	
23	Y	
24	L/W	
26	L	
27	L/W	
28	O	
29	R/W	
30	L/B	
31	Y	
32	GR/R	
34	Y	
35	R	
36	B/R	
37	G/Y	
38	G	
40	SB	
41	W/R	
42	R	

43	V	
51	L/O	
52	BR/W	
53	BR/Y	
54	GR/L	
60	W	
61	B	
62	R	
63	G	
64	SHIELD	
91	BR	
92	L/W	
94	Y/B	
95	G/R	
97	R	
98	G/B	
100	W/R	

Connector No.	M1
Connector Name	FUSE BLOCK (J/B)
Connector Type	NS50FW-M2



Terminal No.	Color of Wire	Signal Name [Specification]
1A	Y	
2A	GR	
3A	W	
4A	Y/G	
5A	V	
6A	L/W	
7A	LG	
8A	W	

Connector No.	M4
Connector Name	DATA LINK CONNECTOR
Connector Type	BD16FN

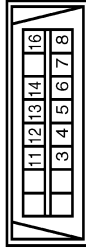

Terminal No.	Color of Wire	Signal Name [Specification]
3	LG	
4	B	
5	B	
6	L	
7	SB	
8	GR	
11	SB	
12	R	
13	L	
14	P	
16	Y	

Connector No.	M8
Connector Name	DOOR MIRROR REMOTE CONTROL SWITCH
Connector Type	TK18FBR



Terminal No.	Color of Wire	Signal Name [Specification]
2	BR	
3	GR/B	
4	V/W	
5	GR/R	
6	Y/G	
8	O	
9	LG	
10	W/B	
11	G/O	
12	V	
13	B	

14	O/L
15	B
16	L/O

A
B
C
D
E
F
G
H
I
J
K
L
M
N
O
P

MIR

JCLWM5430GB

DOOR MIRROR SYSTEM

< WIRING DIAGRAM >

DOOR MIRROR

Connector No.	M19
Connector Name	WIRE TO WIRE
Connector Type	THB07V-CS16-TM4

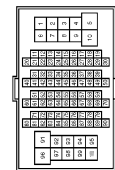

Terminal No.	Color of Wire	Signal Name [Specification]
2	L	-
3	BR	-
5	R/W	-
6	L	-
7	V	-
9	G	-
11	W/B	-
12	BR	-
13	G/R	-
14	B/Y	-
15	W/R	-
16	GR/R	-
18	G/W	-
19	V	-
20	W/G	-
21	B/W	-
22	V	-
23	SHIELD	-
24	G	-
25	O	-
26	Y	-
27	L/O	-
28	Y/R	-
29	L	-
30	R	- [With ICC]
31	P	- [Without ICC]
32	B/SB	-
33	LG/R	-
34	BR/W	-
35	GR/R	-
36	SB	-
37	LG	-
38	L	-
39	P	-
40	W/G	-
42	G/R	-
43	V/W	-

44	LG/B	-
45	R/Y	-
46	B	-
49	GB	-
50	R/B	-
51	W/R	-
52	BR/Y	-
53	O/B	-
54	G/O	-
55	R/B	-
56	LG/R	-
57	GR/R	-
58	Y/G	-
59	V/W	-
60	R	-
63	Y	-
64	R	-
65	W	-
66	G	-
67	B	-
68	SHIELD	-
69	LG/B	-
70	P/L	-
71	L	-
72	R	-
77	Y/B	-
78	Y/L	-
79	Y	-
80	W/R	-
81	Y/L	-
83	BR/W	-
84	L/O	-
86	O	-
87	W/R	-
88	O	-
89	W/L	-
90	GR/L	-
91	W	-
92	G	-
94	W/R	-
96	P/W	-
97	R	-
98	V	-
99	L/W	-
100	P/B	-

Connector No.	M20
Connector Name	WIRE TO WIRE
Connector Type	TH40MW-CS15

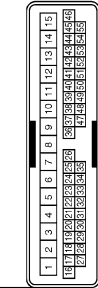

Terminal No.	Color of Wire	Signal Name [Specification]
1	V	-
2	W	-
3	V	-
4	Y	-
5	LG/R	-
6	BR/W	-
8	G	-
10	L	-
11	L/O	-
13	Y	-
14	R	-
15	B	-
18	B	-
19	R	-
20	P	-
22	V	-
23	P/B	-
25	BR/W	-
26	W/R	-
28	W/G	-
33	V/W	-
38	W/B	-
37	BR/Y	-
38	SB	-
39	W/L	-
40	L/W	-
41	Y/G	-
42	P/L	-
43	LG	-
44	SHIELD	-
45	G	-
46	W	-
47	O	-
48	G/W	-
49	Y	-
50	L/Y	-
51	GR/R	-

52	LG/B	-
53	Y	-
54	B	-
55	R	-

JCLWM5431GB

DOOR MIRROR SYSTEM

< WIRING DIAGRAM >

DOOR MIRROR

Connector No.	M22
Connector Name	WIRE TO WIRE
Connector Type	TH40MW-CS-5

1	2	3	4	5	6	7	8	9	10	11	12	13	14	15
16	17	18	19	20	21	22	23	24	25	26	27	28	29	30
31	32	33	34	35	36	37	38	39	40	41	42	43	44	45

Terminal No.	Color of Wire	Signal Name [Specification]
1	G	
2	W	
3	V	
4	P/L	
5	L/R	
6	L/W	
7	G/Y	
8	L	
9	L/W	
10	L	
11	L/W	
12	L	
13	L	
14	R	
15	B	
16	B/W	
17	R	
18	R	
19	R	
20	P	
21	P	
22	Y/R	
23	LG/B	
24	W/R	
25	W/R	
26	G/O	
27	G/O	
28	Y/B	
29	V	
30	W/L	
31	W/L	
32	W/L	
33	L/O	
34	SHIELD	
35	Y	
36	W	
37	LG	
38	L/R	
39	Y	
40	R/B	
41	LG	
42	G	
43	B	
44	B	
45	R	

Connector No.	M68
Connector Name	BCM (BODY CONTROL MODULE)
Connector Type	TH40FB-NH

1	2	3	4	5	6	7	8	9	10	11	12	13	14	15	16	17	18	19	20
21	22	23	24	25	26	27	28	29	30	31	32	33	34	35	36	37	38	39	40

Terminal No.	Color of Wire	Signal Name [Specification]
2	BR/Y	COMBI SW INPUT 5
3	GR	COMBI SW INPUT 4
4	L	COMBI SW INPUT 3
5	G	COMBI SW INPUT 2
6	V	COMBI SW INPUT 1
7	Y	POWER WINDOW SW COMM
8	R	STOP LAMP SW 1
9	R	L&R SENSOR SERIAL LINK
10	P/B	OPTICAL SENSOR
11	L/O	DIMMER SIGNAL
12	Y/G	SENSOR PWR SPLY
13	B/Y	RECEIVER SENSOR GND
14	R	RECEIVER PWR SPLY
15	B	KYLS ENT RECEIVER COMM
16	P	NATS ANT AMP
17	P	KYLS ENT RECEIVER RSSI
18	GR/R	SECURITY IND CONT
19	SB	DONGLE LINK
20	LG/R	NATS ANT AMP
21	W	HAZARD SW
22	W/L	BK DOOR ORNB SW
23	W/G	DR DOOR UNLK SW SENSOR
24	LG	COMBI SW OUTPUT 9
25	Y	COMBI SW OUTPUT 4
26	R/W	COMBI SW OUTPUT 3
27	SR	COMBI SW OUTPUT 2
28	G/Y	SHIFT P
29	L	CAN-H
30	P	CAN-L

Connector No.	M70
Connector Name	BCM (BODY CONTROL MODULE)
Connector Type	FE40SPW-FH4B-SA

56	57	58	59	60	61	62	63	64
65	66	67	68	69	70			

Terminal No.	Color of Wire	Signal Name [Specification]
56	W/R	INT ROOM LAMP PWR SPLY
57	LG	BAT (FUSE)
58	G	PASSENGER DOOR UNLK OUTPUT
59	G	TURIN SIGNAL LH OUTPUT
60	G/Y	TURIN SIGNAL RH OUTPUT
61	R	STEP LAMP CONT
62	BR	ROOM LAMP TIMER CONT
63	GR/R	CRANKING REQUEST
64	R	ALL DOOR LOCK OUTPUT
65	V	DR DOOR FUEL LID UNLK OUTPUT
66	B	GND
67	Y	PW PWR SPLY (IGN)
68	W	PW PWR SPLY (BAT)
69	Y	BAT (F/L)
70	Y	BAT (F/L)

Connector No.	M75
Connector Name	AUTOMATIC DRIVE POSITIONER CONTROL UNIT
Connector Type	TH24PW-NH

1	2	3	4	5	6	7	8	9	10	11	12
13	14	15	16	17	18	19	20	21	22	23	24

Terminal No.	Color of Wire	Signal Name [Specification]
1	Y	UPWARD
2	GR/B	SELECT RH
3	Y/G	UPWARD
4	GR/R	LEFTWARD
5	R/B	MIR SEAS UP DOWN (RH)
6	L/Y	MIR SEAS UP DOWN (LH)
7	P	FORWARD
8	LG/R	RX TX

10	L/O	MIR MTR UP (RH)
11	Y/B	MIR MTR LEFT (RH)
12	SB	MIR MTR DOWN RIGHT (LH)
13	LG	DOWNWARD
14	BR	SELECT LH
15	O/L	DOWNWARD
16	V/W	RIGHTWARD
17	L/R	MIR SEAS LEFT & RIGHT (RH)
18	G/W	MIR SEAS LEFT & RIGHT (LH)
19	G	BACKWARD
20	Y	SENS GND
21	W/L	SENS POWER
22	V	MIR MTR DOWN RIGHT (RH)
23	L/W	MIR MTR UP (LH)
24	BR/Y	MIR MTR LEFT (LH)

A
B
C
D
E
F
G
H
I
J
K
L
M
N
O
P

MIR

DOOR MIRROR SYSTEM

< WIRING DIAGRAM >

DOOR MIRROR

Connector No.	M77
Connector Name	WIRE TO WIRE
Connector Type	TH8DFW-CS16-TM4

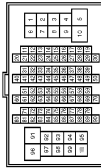

Terminal No.	Color of Wire	Signal Name [Specification]
1	W	
2	L/W	
3	R/B	
4	L	
5	Y	
7	W/G	
8	P/B	
9	W/B	
10	L	
11	L	
12	P	-- [With ICC]
12	R	-- [Without ICC]
13	P/B	
14	BR	
15	O/L	
16	SB	
17	P	
18	BR	
19	Y/G	
20	BR/Y	
21	V	
22	L	
23	Y	
24	L/W	
26	L	
27	L/W	
28	O	
28	R/W	
30	O/L	
31	Y	
32	GR/R	
34	Y	
35	R	
36	B/O	
37	G/Y	
38	G	
40	SB	
41	W/R	

42	R	
43	V	
51	L/O	
52	BR/W	
53	BR/Y	
54	GR/L	
60	W	
61	B	
62	G	
63	R	
64	SHIELD	
91	BR	
92	L/W	
94	Y/B	
95	L/R	
97	R	
98	O/L	
100	W/B	

Connector No.	M104
Connector Name	AUTOMATIC DRIVE POSITIONER CONTROL UNIT
Connector Type	HS8DFW-CS



Terminal No.	Color of Wire	Signal Name [Specification]
25	W/R	UPWARD
26	L	BACKWARD
27	P	UPWARD
28	G	DOWNWARD
29	W/B	UPWARD/FRONTWARD
30	B	GND

Connector No.	M115
Connector Name	CIRCUIT BREAKER
Connector Type	MS8DFW-P-LC



Terminal No.	Color of Wire	Signal Name [Specification]
1	Y	
2	W/R	

Connector No.	M125
Connector Name	CAN GATEWAY
Connector Type	TH12FW-NH

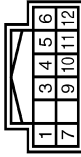

Terminal No.	Color of Wire	Signal Name [Specification]
1	L	CAN-H
3	Y	BATTERY
4	L	CAN-H
5	B	GND
8	L	CAN-H
7	B	CAN-L
9	GR	IGNITION
10	R	CAN-L
11	B	GND
12	R	CAN-L

JCLWM5433GB

AUTO ANTI-DAZZLING INSIDE MIRROR SYSTEM

< WIRING DIAGRAM >

AUTO ANTI-DAZZLING INSIDE MIRROR SYSTEM

Wiring Diagram - INSIDE MIRROR SYSTEM -

INFOID:000000006257227

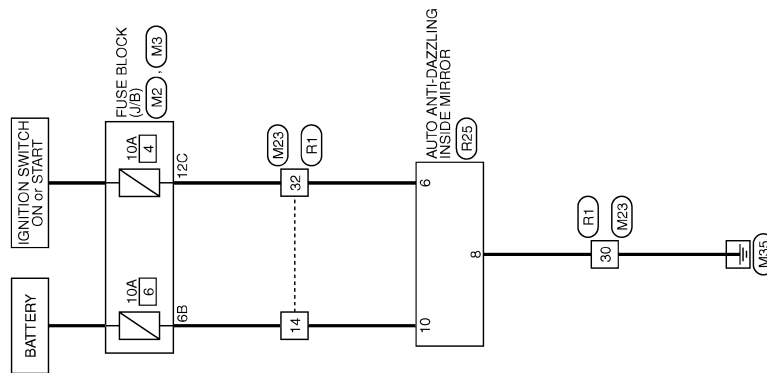

INSIDE MIRROR

2010/05/13

JCLWM5434GB

A
B
C
D
E
F
G
H
I
J
K
L
M
N
O
P

MIR

AUTO ANTI-DAZZLING INSIDE MIRROR SYSTEM

< WIRING DIAGRAM >

INSIDE MIRROR

Connector No.	M2
Connector Name	FUSE BLOCK (J/B)
Connector Type	NS10FW-CS



4B	6B	2B	1B
10B	9B	8B	7B
6B	5B	6B	5B

Terminal No.	Color of Wire	Signal Name [Specification]
1B	R	-
3B	R	-
4B	B	-
5B	BR	-
6B	Y	-
7B	G	-
8B	L/O	-
10B	W/B	-

Connector No.	M3
Connector Name	FUSE BLOCK (J/B)
Connector Type	NS12FW-CS



5C	4C	3C	2C	1C
12C	11C	10C	9C	8C
7C	6C	5C	4C	3C
2C	1C	10C	9C	8C

Terminal No.	Color of Wire	Signal Name [Specification]
6C	R	-
7C	B	-
8C	W	-
10C	GR	-
11C	R/L	-
12C	GR/L	-

Connector No.	M23
Connector Name	WIRE TO WIRE
Connector Type	TH32MW-NH



1	2	3	4	5	6	7	8	9	10	11	12	13	14	15	16	17	18	19	20	21	22	23	24	25	26	27	28	29	30	31	32
---	---	---	---	---	---	---	---	---	----	----	----	----	----	----	----	----	----	----	----	----	----	----	----	----	----	----	----	----	----	----	----

Terminal No.	Color of Wire	Signal Name [Specification]
1	W	-
4	Y	-
7	B	-
8	Y/L	-
10	B	-
11	R	-
12	Y	-
13	SHIELD	-
14	Y	-
15	W/R	-
16	L/O	-
17	Y	-
20	W	-
22	SB	-
23	Y/R	-
24	SHIELD	-
25	Y/G	-
26	L/O	-
27	W/G	-
28	Y	-
29	L	-
30	B/SB	-
31	SB	-
32	GR/L	-

Connector No.	R1
Connector Name	WIRE TO WIRE
Connector Type	TH32FW-NH



16	15	14	13	12	11	10	9	8	7	6	5	4	3	2	1
32	31	30	29	28	27	26	25	24	23	22	21	20	19	18	17

Terminal No.	Color of Wire	Signal Name [Specification]
1	W	-
4	Y	-
7	B	-
8	Y/L	-
10	B	-
11	R	-
12	Y	-
13	SHIELD	-
14	B/Y	-
15	W/R	-
16	L/O	-
17	Y	-
20	W	-
22	SB	-
23	Y	-
24	SHIELD	-
25	Y/G	-
26	L	-
27	W/G	-
28	Y	-
29	L	-
30	B/SB	-
31	BR	-
32	B/R	-

Connector No.	R23
Connector Name	AUTO ANTI-DAZZLING INSIDE MIRROR
Connector Type	TH10FB-NH



10	8	6
----	---	---

Terminal No.	Color of Wire	Signal Name [Specification]
6	B/R	-
8	B	-
10	B/Y	-

DIAGNOSIS AND REPAIR WORKFLOW

< BASIC INSPECTION >

BASIC INSPECTION

DIAGNOSIS AND REPAIR WORKFLOW

Work Flow

INFOID:000000006257228

DETAILED FLOW

1.OBTAIN INFORMATION ABOUT SYMPTOM

Interview the customer to obtain the malfunction information (conditions and environment when the malfunction occurred) as much as possible when the customer brings the vehicle in.

>> GO TO 2.

2.CHECK DTC

Perform self-diagnosis for automatic drive positioner (ADP) with CONSULT-III.

Is any DTC detected?

YES >> Refer to [ADP-31, "DTC Index"](#)

NO >> GO TO 3.

3.REPRODUCE THE MALFUNCTION INFORMATION

Check the malfunction on the vehicle that the customer describes.

Inspect the relation of the symptoms and the condition when the symptoms occur.

>> GO TO 4.

4.IDENTIFY THE MALFUNCTIONING SYSTEM WITH "SYMPTOM DIAGNOSIS"

Use "Symptom diagnosis" from the symptom inspection result in step 3. Then identify where to start performing the diagnosis based on possible causes and symptoms.

>> GO TO 5.

5.IDENTIFY MALFUNCTIONING PARTS WITH "COMPONENT DIAGNOSIS"

Perform the diagnosis with "Component diagnosis" of the applicable system.

>> GO TO 6.

6.REPAIR OR REPLACE THE MALFUNCTIONING PARTS

Repair or replace the specified malfunctioning parts.

>> GO TO 7.

7.FINAL CHECK

Check that malfunctions are not reproduced when obtaining the malfunction information from the customer, referring to the symptom inspection result in step 3.

Are all malfunctions corrected?

YES >> INSPECTION END

NO >> GO TO 4.

A
B
C
D
E
F
G
H
I
J
K
MIR
M
N
O
P

DOOR MIRROR REMOTE CONTROL SWITCH

< DTC/CIRCUIT DIAGNOSIS >

DTC/CIRCUIT DIAGNOSIS

DOOR MIRROR REMOTE CONTROL SWITCH OPEN/CLOSE SWITCH

OPEN/CLOSE SWITCH : Component Inspection

INFOID:000000006257229

1. CHECK OPEN/CLOSE SWITCH

1. Turn ignition switch OFF.
2. Disconnect door mirror remote control switch connector.
3. Check continuity between door mirror remote control switch terminals.

[Driver side]

Door mirror remote control switch		Condition		Continuity
Terminal				
12	10	Open/close switch	OPEN	Existed
13	8		CLOSE	
12	8			
13	10			

[Passenger side]

Door mirror remote control switch		Condition		Continuity
Terminal				
12	11	Open/close switch	OPEN	Existed
13	9		CLOSE	
12	9			
13	11			

Is the inspection result normal?

- YES >> INSPECTION END
NO >> Replace door mirror remote control switch.

REVERSE INTERLOCK DOOR MIRROR DOES NOT OPERATE

< SYMPTOM DIAGNOSIS >

SYMPTOM DIAGNOSIS

REVERSE INTERLOCK DOOR MIRROR DOES NOT OPERATE

Diagnosis Procedure

INFOID:000000006257230

1. CHECK DOOR MIRROR (MANUAL FUNCTION)

Check door mirror function with door mirror remote control switch.
Refer to [ADP-126. "DOOR MIRROR : Diagnosis Procedure"](#).

Is the inspection result normal?

YES >> GO TO 2.

NO >> Repair or replace the malfunctioning parts.

2. CHECK DTC

Check DTC for TCM.
Refer to [TM-78. "DTC Index"](#).

Is the inspection result normal?

YES >> GO TO 3.

NO >> Repair or replace the malfunctioning parts.

3. CONFIRM THE OPERATION

Confirm the operation again.

Is the result normal?

YES >> Check intermittent incident. Refer to [GI-40. "Intermittent Incident"](#).

NO >> GO TO 1.

A
B
C
D
E
F
G
H
I
J
K
M
N
O
P

MIR

SQUEAK AND RATTLE TROUBLE DIAGNOSES

< SYMPTOM DIAGNOSIS >

SQUEAK AND RATTLE TROUBLE DIAGNOSES

Work Flow

INFOID:000000006257247

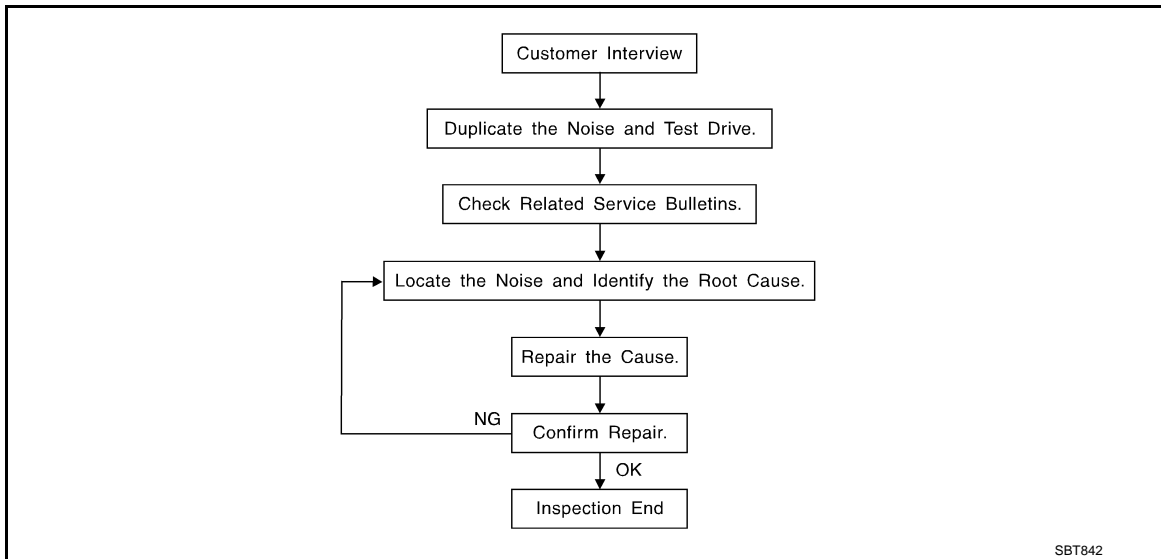

CUSTOMER INTERVIEW

Interview the customer if possible, to determine the conditions that exist when the noise occurs. Use the Diagnostic Worksheet during the interview to document the facts and conditions when the noise occurs and any of customer's comments; refer to [MIR-28, "Diagnostic Worksheet"](#). This information is necessary to duplicate the conditions that exist when the noise occurs.

- The customer may not be able to provide a detailed description or the location of the noise. Attempt to obtain all the facts and conditions that exist when the noise occurs (or does not occur).
- If there is more than one noise in the vehicle, perform a diagnosis and repair the noise that the customer is concerned about. This can be accomplished by performing a cruise test on the vehicle with the customer.
- After identifying the type of noise, isolate the noise in terms of its characteristics. The noise characteristics are provided so the customer, service adviser and technician are all speaking the same language when defining the noise.
- Squeak – (Like tennis shoes on a clean floor)
Squeak characteristics include the light contact/fast movement/brought on by road conditions/hard surfaces = higher pitch noise/softer surfaces = lower pitch noises/edge to surface = chirping
- Creak – (Like walking on an old wooden floor)
Creak characteristics include firm contact/slow movement/twisting with a rotational movement/pitch dependent on materials/often brought on by activity.
- Rattle – (Like shaking a baby rattle)
Rattle characteristics include the fast repeated contact/vibration or similar movement/loose parts/missing clip or fastener/incorrect clearance.
- Knock – (Like a knock on a door)
Knock characteristics include hollow sounding/sometimes repeating/often brought on by driver action.
- Tick – (Like a clock second hand)
Tick characteristics include gentle contacting of light materials/loose components/can be caused by driver action or road conditions.
- Thump – (Heavy, muffled knock noise)
Thump characteristics include softer knock/dead sound often brought on by activity.
- Buzz – (Like a bumblebee)
Buzz characteristics include high frequency rattle/firm contact.
- Often the degree of acceptable noise level will vary depending up on the person. A noise that you may judge as acceptable may be very irritating to the customer.
- Weather conditions, especially humidity and temperature, may have a great effect on noise level.

DUPLICATE THE NOISE AND TEST DRIVE

If possible, drive the vehicle with the customer until the noise is duplicated. Note any additional information on the Diagnostic Worksheet regarding the conditions or location of the noise. This information can be used to duplicate the same conditions when you confirm the repair.

SQUEAK AND RATTLE TROUBLE DIAGNOSES

< SYMPTOM DIAGNOSIS >

If the noise can be duplicated easily during the test drive, to help identify the source of the noise, try to duplicate the noise with the vehicle stopped by doing one or all of the following:

- 1) Close a door.
 - 2) Tap or push/pull around the area where the noise appears to be coming from.
 - 3) Rev the engine.
 - 4) Use a floor jack to recreate vehicle "twist".
 - 5) At idle, apply engine load (electrical load, half-clutch on M/T models, drive position on A/T models).
 - 6) Raise the vehicle on a hoist and hit a tire with a rubber hammer.
- Drive the vehicle and attempt to duplicate the conditions the customer states exist when the noise occurs.
 - If it is difficult to duplicate the noise, drive the vehicle slowly on an undulating or rough road to stress the vehicle body.

CHECK RELATED SERVICE BULLETINS

After verifying the customer concern or symptom, check ASIST for Technical Service Bulletins (TSBs) related to that concern or symptom.

If a TSB relates to the symptom, follow the procedure to repair the noise.

LOCATE THE NOISE AND IDENTIFY THE ROOT CAUSE

1. Narrow down the noise to a general area. To help pinpoint the source of the noise, use a listening tool (Chassis Ear: J-39570, Engine Ear and mechanics stethoscope).
2. Narrow down the noise to a more specific area and identify the cause of the noise by:
 - Removing the components in the area that you suspect the noise is coming from.
Do not use too much force when removing clips and fasteners, otherwise clips and fastener can be broken or lost during the repair, resulting in the creation of new noise.
 - Tapping or pushing/pulling the component that you suspect is causing the noise.
Do not tap or push/pull the component with excessive force, otherwise the noise will be eliminated only temporarily.
 - Feeling for a vibration with your hand by touching the component(s) that you suspect is (are) causing the noise.
 - Placing a piece of paper between components that you suspect are causing the noise.
 - Looking for loose components and contact marks.
Refer to [MIR-26, "Inspection Procedure"](#).

REPAIR THE CAUSE

- If the cause is a loose component, tighten the component securely.
- If the cause is insufficient clearance between components:
 - Separate components by repositioning or loosening and retightening the component, if possible.
 - Insulate components with a suitable insulator such as urethane pads, foam blocks, felt cloth tape or urethane tape. A Nissan Squeak and Rattle Kit (J-43980) is available through your authorized Nissan Parts Department.

CAUTION:

Do not use excessive force as many components are constructed of plastic and may be damaged.

NOTE:

Always check with the Parts Department for the latest parts information.

The following materials are contained in the Nissan Squeak and Rattle Kit (J-43980). Each item can be ordered separately as needed.

URETHANE PADS [1.5 mm (0.059 in) thick]

Insulates connectors, harness, etc.

76268-9E005: 100 × 135 mm (3.94 × 5.31 in)/76884-71L01: 60 × 85 mm (2.36 × 3.35 in)/76884-71L02: 15 × 25 mm (0.59 × 0.98 in)

INSULATOR (Foam blocks)

Insulates components from contact. Can be used to fill space behind a panel.

73982-9E000: 45 mm (1.77 in) thick, 50 × 50 mm (1.97 × 1.97 in)/73982-

50Y00: 10 mm (0.39 in) thick, 50 × 50 mm (1.97 × 1.97 in)

INSULATOR (Light foam block)

80845-71L00: 30 mm (1.18 in) thick, 30 × 50 mm (1.18 × 1.97in)

FELT CLOTHTAPE

Used to insulate where movement does not occur. Ideal for instrument panel applications.

68370-4B000: 15 × 25 mm (0.59 × 0.98 in) pad/68239-13E00: 5 mm (0.20 in) wide tape roll

The following materials, not found in the kit, can also be used to repair squeaks and rattles.

UHMW (TEFLON) TAPE

SQUEAK AND RATTLE TROUBLE DIAGNOSES

< SYMPTOM DIAGNOSIS >

Insulates where slight movement is present. Ideal for instrument panel applications.

SILICONE GREASE

Used in place of UHMW tape that will be visible or not fit. Will only last a few months.

SILICONE SPRAY

Use when grease cannot be applied.

DUCT TAPE

Use to eliminate movement.

CONFIRM THE REPAIR

Confirm that the cause of a noise is repaired by test driving the vehicle. Operate the vehicle under the same conditions as when the noise originally occurred. Refer to the notes on the Diagnostic Worksheet.

Inspection Procedure

INFOID:000000006257248

Refer to Table of Contents for specific component removal and installation information.

INSTRUMENT PANEL

Most incidents are caused by contact and movement between:

1. The cluster lid A and instrument panel
2. Acrylic lens and combination meter housing
3. Instrument panel to front pillar garnish
4. Instrument panel to windshield
5. Instrument panel mounting pins
6. Wiring harnesses behind the combination meter
7. A/C defroster duct and duct joint

These incidents can usually be located by tapping or moving the components to duplicate the noise or by pressing on the components while driving to stop the noise. Most of these incidents can be repaired by applying felt cloth tape or silicon spray (in hard to reach areas). Urethane pads can be used to insulate wiring harness.

CAUTION:

Do not use silicone spray to isolate a squeak or rattle. If you saturate the area with silicone, you will not be able to recheck the repair.

CENTER CONSOLE

Components to pay attention to include:

1. Shifter assembly cover to finisher
2. A/C control unit and cluster lid C
3. Wiring harnesses behind audio and A/C control unit

The instrument panel repair and isolation procedures also apply to the center console.

DOORS

Pay attention to the:

1. Finisher and inner panel making a slapping noise
2. Inside handle escutcheon to door finisher
3. Wiring harnesses tapping
4. Door striker out of alignment causing a popping noise on starts and stops

Tapping or moving the components or pressing on them while driving to duplicate the conditions can isolate many of these incidents. You can usually insulate the areas with felt cloth tape or insulator foam blocks from the Nissan Squeak and Rattle Kit (J-43980) to repair the noise.

TRUNK

Trunk noises are often caused by a loose jack or loose items put into the trunk by the owner.

In addition look for:

1. Trunk lid dumpers out of adjustment
2. Trunk lid striker out of adjustment
3. The trunk lid torsion bars knocking together
4. A loose license plate or bracket

SQUEAK AND RATTLE TROUBLE DIAGNOSES

< SYMPTOM DIAGNOSIS >

Most of these incidents can be repaired by adjusting, securing or insulating the item(s) or component(s) causing the noise.

SUNROOF/HEADLINING

Noises in the sunroof/headlining area can often be traced to one of the following:

1. Sunroof lid, rail, linkage or seals making a rattle or light knocking noise
2. Sunvisor shaft shaking in the holder
3. Front or rear windshield touching headlining and squeaking

Again, pressing on the components to stop the noise while duplicating the conditions can isolate most of these incidents. Repairs usually consist of insulating with felt cloth tape.

SEATS

When isolating seat noise it's important to note the position the seat is in and the load placed on the seat when the noise is present. These conditions should be duplicated when verifying and isolating the cause of the noise.

Cause of seat noise include:

1. Headrest rods and holder
2. A squeak between the seat pad cushion and frame
3. The rear seatback lock and bracket

These noises can be isolated by moving or pressing on the suspected components while duplicating the conditions under which the noise occurs. Most of these incidents can be repaired by repositioning the component or applying urethane tape to the contact area.

UNDERHOOD

Some interior noise may be caused by components under the hood or on the engine wall. The noise is then transmitted into the passenger compartment.

Causes of transmitted underhood noise include:

1. Any component mounted to the engine wall
2. Components that pass through the engine wall
3. Engine wall mounts and connectors
4. Loose radiator mounting pins
5. Hood bumpers out of adjustment
6. Hood striker out of adjustment

These noises can be difficult to isolate since they cannot be reached from the interior of the vehicle. The best method is to secure, move or insulate one component at a time and test drive the vehicle. Also, engine RPM or load can be changed to isolate the noise. Repairs can usually be made by moving, adjusting, securing, or insulating the component causing the noise.

A
B
C
D
E
F
G
H
I
J
K
M
N
O
P

MIR

SQUEAK AND RATTLE TROUBLE DIAGNOSES

< SYMPTOM DIAGNOSIS >

Diagnostic Worksheet

INFOID:000000006257249



SQUEAK & RATTLE DIAGNOSTIC WORKSHEET

Dear Infiniti Customer:

We are concerned about your satisfaction with your Infiniti vehicle. Repairing a squeak or rattle sometimes can be very difficult. To help us fix your Infiniti right the first time, please take a moment to note the area of the vehicle where the squeak or rattle occurs and under what conditions. You may be asked to take a test drive with a service consultant or technician to ensure we confirm the noise you are hearing.

I. WHERE DOES THE NOISE COME FROM? (circle the area of the vehicle)

The illustrations are for reference only, and may not reflect the actual configuration of your vehicle.

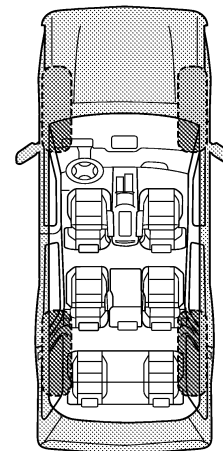
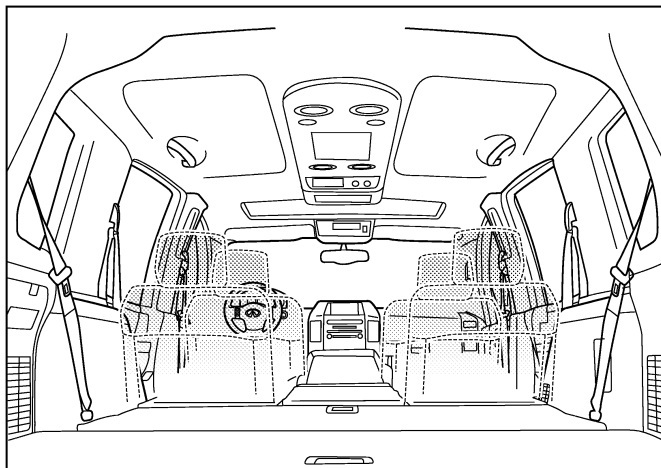
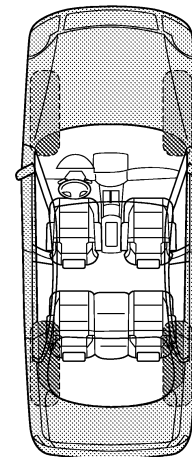
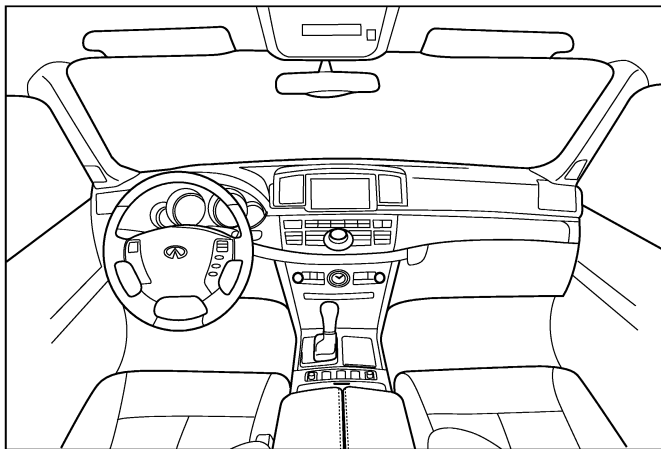

Continue to page 2 of the worksheet and briefly describe the location of the noise or rattle. In addition, please indicate the conditions which are present when the noise occurs.

PIIB8741E

SQUEAK AND RATTLE TROUBLE DIAGNOSES

< SYMPTOM DIAGNOSIS >

SQUEAK & RATTLE DIAGNOSTIC WORKSHEET - page 2

Briefly describe the location where the noise occurs:

II. WHEN DOES IT OCCUR? (please check the boxes that apply)

- | | |
|---|--|
| <input type="checkbox"/> anytime | <input type="checkbox"/> after sitting out in the rain |
| <input type="checkbox"/> 1st time in the morning | <input type="checkbox"/> when it is raining or wet |
| <input type="checkbox"/> only when it is cold outside | <input type="checkbox"/> dry or dusty conditions |
| <input type="checkbox"/> only when it is hot outside | <input type="checkbox"/> other: |

III. WHEN DRIVING:

- through driveways
- over rough roads
- over speed bumps
- only about ____ mph
- on acceleration
- coming to a stop
- on turns: left, right or either (circle)
- with passengers or cargo
- other: _____
- after driving ____ miles or ____ minutes

IV. WHAT TYPE OF NOISE

- squeak (like tennis shoes on a clean floor)
- creak (like walking on an old wooden floor)
- rattle (like shaking a baby rattle)
- knock (like a knock at the door)
- tick (like a clock second hand)
- thump (heavy, muffled knock noise)
- buzz (like a bumble bee)

TO BE COMPLETED BY DEALERSHIP PERSONNEL

Test Drive Notes:

	YES	NO	Initials of person performing
Vehicle test driven with customer	<input type="checkbox"/>	<input type="checkbox"/>	_____
- Noise verified on test drive	<input type="checkbox"/>	<input type="checkbox"/>	_____
- Noise source located and repaired	<input type="checkbox"/>	<input type="checkbox"/>	_____
- Follow up test drive performed to confirm repair	<input type="checkbox"/>	<input type="checkbox"/>	_____

VIN: _____ Customer Name: _____
W.O.# _____ Date: _____

This form must be attached to Work Order

PIIB8742E

A
B
C
D
E
F
G
H
I
J
K
M
N
O
P

MIR

INSIDE MIRROR

< REMOVAL AND INSTALLATION >

REMOVAL AND INSTALLATION

INSIDE MIRROR

Exploded View

INFOID:000000006257234

With rain sensor models

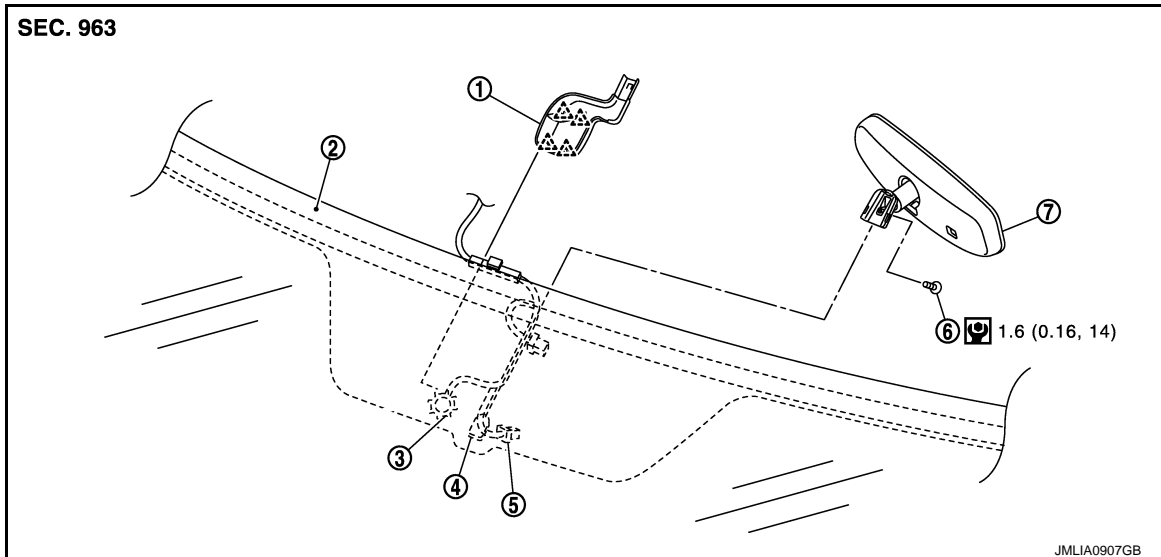

- | | | |
|----------------------|----------------------|----------------|
| 1. Rain sensor cover | 2. Windshield glass | 3. Rain sensor |
| 4. Mirror base | 5. Harness connector | 6. TORX bolt |
| 7. Inside mirror | | |

 : Pawl

Refer to [GI-4, "Components"](#) for symbols in the figure.

Without rain sensor models

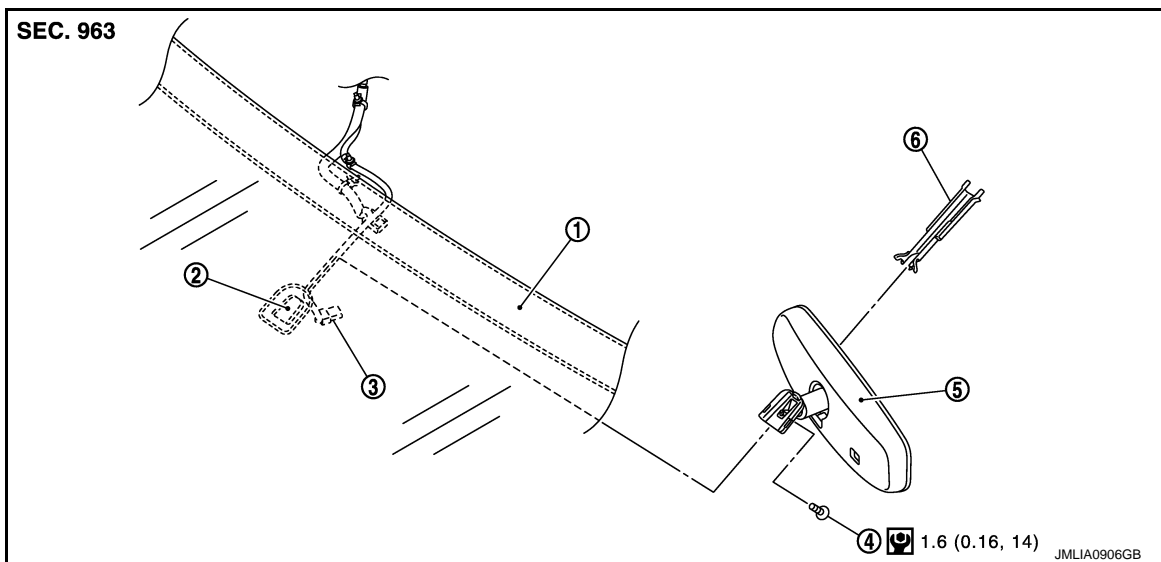

- | | | |
|---------------------|------------------|------------------------|
| 1. Windshield glass | 2. Mirror base | 3. Harness connector |
| 4. TORX bolt | 5. Inside mirror | 6. Inside mirror cover |

Refer to [GI-4, "Components"](#) for symbols in the figure.

Removal and Installation

INFOID:000000006257235

WITH RAIN SENSOR MODELS

Revision: 2010 May

MIR-30

2011 QX56

INSIDE MIRROR

< REMOVAL AND INSTALLATION >

Removal

1. Disengage rain sensor cover fixing pawls with a remover tool to remove.
2. Disconnect harness connector from inside mirror.
3. Loosen TORX bolt and slide inside mirror upward to remove.

Installation

Install in the reverse order of removal.

WITHOUT RAIN SENSOR MODELS

Removal

1. Remove inside mirror cover.
2. Disconnect harness connector from inside mirror.
3. Loosen TORX bolt and slide inside mirror upward to remove.

Installation

Install in the reverse order of removal.

A

B

C

D

E

F

G

H

I

J

K

MIR

M

N

O

P

OUTSIDE MIRROR

< REMOVAL AND INSTALLATION >

OUTSIDE MIRROR

Exploded View

INFOID:000000006257236

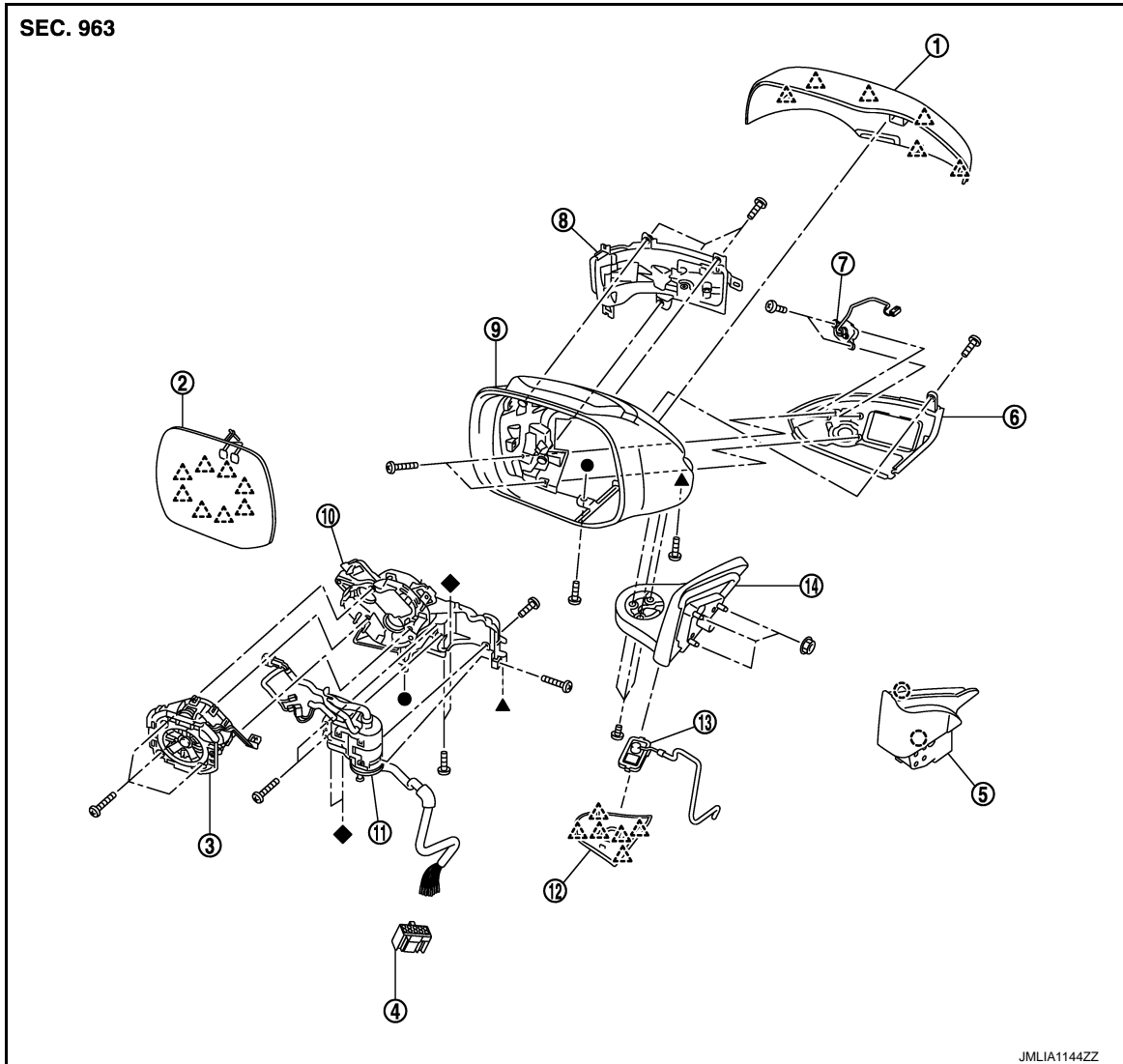

- | | | |
|-----------------------|--------------------------|-------------------------|
| 1. Door mirror cover | 2. Glass mirror | 3. Actuator assembly |
| 4. Connector | 5. Door mirror cover | 6. Side camera finisher |
| 7. Around view camera | 8. Side turn signal lamp | 9. Housing |
| 10. Bracket | 11. Power fold unit | 12. Base cover |
| 13. Puddle lamp | 14. Base | |

- : Clip
△ : Pawl

DOOR MIRROR ASSEMBLY

DOOR MIRROR ASSEMBLY : Removal and Installation

INFOID:000000006257237

REMOVAL

1. Remove front door finisher and door mirror corner cover. Refer to [INT-14, "Removal and Installation"](#).
2. Disconnect door mirror assembly harness connector.
3. Remove door mirror mounting nuts, and then remove door mirror assembly.

OUTSIDE MIRROR

< REMOVAL AND INSTALLATION >

INSTALLATION

Note the following item, and then install in the reverse order of removal.

CAUTION:

Perform camera image calibration (with side camera models). Refer to [AV-112, "Work Procedure"](#).

DOOR MIRROR ASSEMBLY : Disassembly and Assembly

INFOID:000000006257238

DISASSEMBLY

1. Remove door mirror assembly from front door panel. Refer to [MIR-32, "DOOR MIRROR ASSEMBLY : Removal and Installation"](#).
2. Remove glass mirror. Refer to [MIR-35, "GLASS MIRROR : Removal and Installation"](#).
3. Remove door mirror cover. Refer to [MIR-36, "DOOR MIRROR COVER : Removal and Installation"](#).
4. Remove actuator.
 1. Remove actuator (1) fixing screws (A).

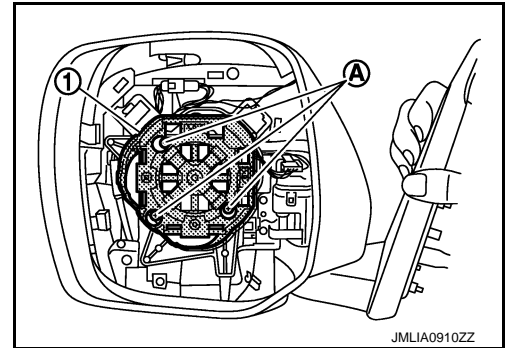

2. Disconnect the harness connectors behind the actuator.

NOTE:

Disconnect the harness connector (B) of automatic driving position system (2) if equipped.

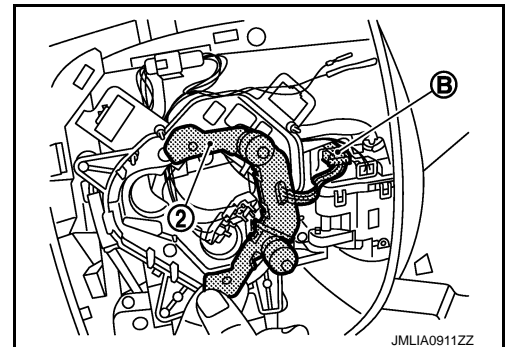

5. Remove side camera finisher assembly (1).
 1. Remove side camera finisher fixing screw (A).

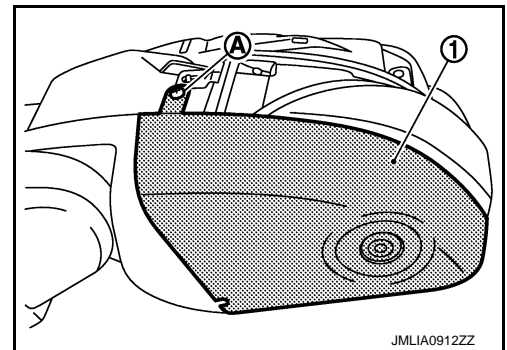

A
B
C
D
E
F
G
H
I
J
K
M
N
O
P

MIR

OUTSIDE MIRROR

< REMOVAL AND INSTALLATION >

2. Disconnect harness connector (B), and remove screws (C) and pawl (D) fixing the side camera finisher (1) to housing.

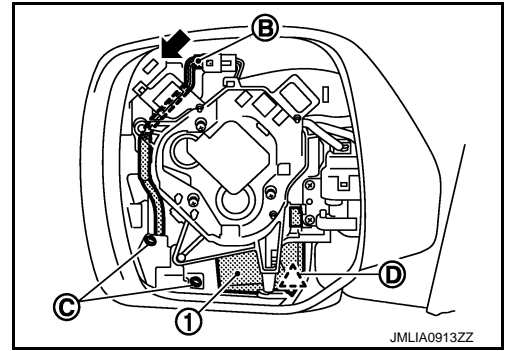

3. Remove side turn signal lamp fixing screws (E), and then remove side turn signal lamp.

NOTE:

Pull slightly side camera finisher (1) covering side turn signal lamp bottom screw.

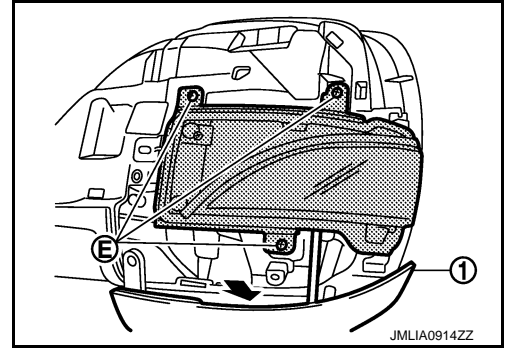

4. Remove side camera finisher assembly.
5. Remove around view camera. Refer to [AV-233. "Removal and Installation"](#).

6. Remove all the harness connector terminal from the connector.

NOTE:

Write a short note to describe connector terminal layout before starting operation.

7. Remove base.

1. Remove base cover.
Remove base cover fixing pawls with a flat-bladed screwdriver (A) wrapped into a tape.

CAUTION:

Apply protective tape (B) around the base to protect the surface from damage.

 : Pawl

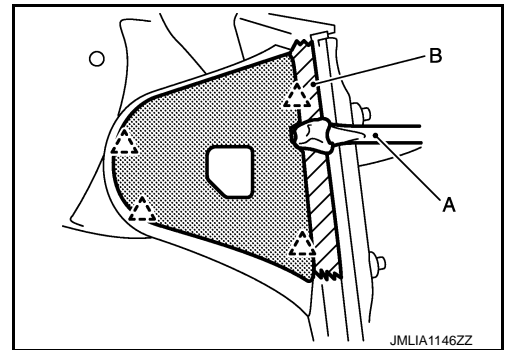

2. Remove puddle lamp. Refer to [INL-79. "Removal and Installation"](#).
3. Remove base mounting bolts located under base cover.
4. Remove base.

8. Remove the fixing screws (A), and then remove power fold unit and bracket from housing.

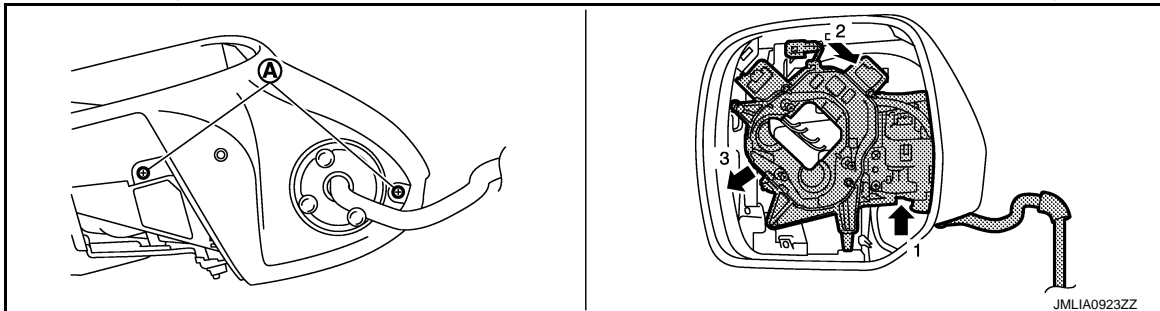

OUTSIDE MIRROR

< REMOVAL AND INSTALLATION >

9. Remove fixing screws (A), (B) and then remove power fold unit (2) from bracket (1).

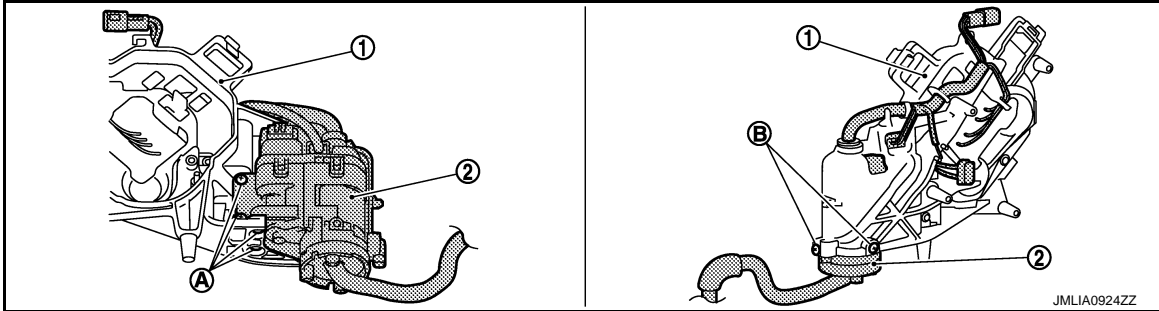

ASSEMBLY

Assemble in the reverse order of disassembly.

GLASS MIRROR

GLASS MIRROR : Removal and Installation

INFOID:000000006257239

REMOVAL

1. Remove door mirror assembly from front door. Refer to [MIR-32, "DOOR MIRROR ASSEMBLY : Removal and Installation"](#).
2. Remove glass mirror.
 1. Place the glass mirror upward.
 2. Put a strip of protective tape (B) on housing assembly.
 3. As shown in the figure, insert a small flat-bladed screwdriver (A) between glass mirror (1) and actuator (2). Push up both pawls simultaneously to remove glass mirror lower half side.

NOTE:

Insert flat-bladed screwdriver into recesses, and push up while rotating (twisting) to make work easier.

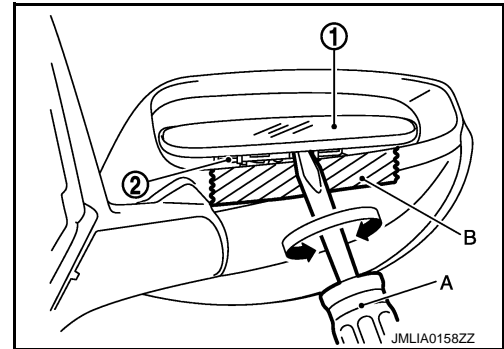

4. Remove terminals (A) of mirror heater attachment from glass mirror (1) if equipped.

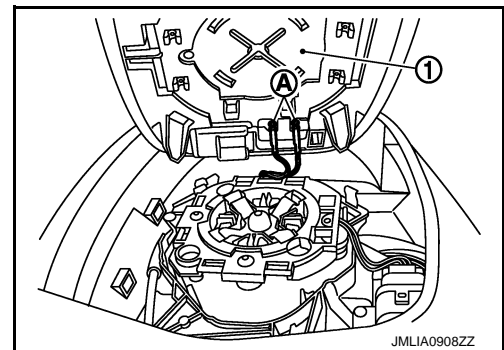

3. Lightly lift up lower side of glass mirror, and detach both pawls of upper side as if pulling it out to disassemble glass mirror from actuator.

NOTE:

Be careful not to allow grease on sealing agent in center of mirror or back side of glass mirror.

INSTALLATION

Note the following item, and then install in the reverse order in the reverse order of disassembly.

CAUTION:

After installation, visually check that pawls are securely engaged.

DOOR MIRROR COVER

OUTSIDE MIRROR

< REMOVAL AND INSTALLATION >

DOOR MIRROR COVER : Removal and Installation

INFOID:000000006257240

CAUTION:

Never damage the mirror bodies.

REMOVAL

1. Remove the glass mirror. Refer to [MIR-35, "GLASS MIRROR : Removal and Installation"](#).
2. Remove the pawls (A), and disassemble door mirror cover from door mirror assembly.

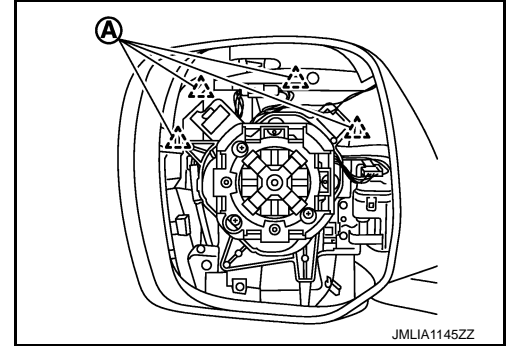

INSTALLATION

Note the following item, and then install in the reverse order of removal.

CAUTION:

After installation, visually check that all the pawls are securely engaged.

SIDE CAMERA FINISHER ASSEMBLY

SIDE CAMERA FINISHER ASSEMBLY : Removal and Installation

INFOID:000000006257241

Disassembly

1. Remove door mirror assembly from front door panel. Refer to [MIR-32, "DOOR MIRROR ASSEMBLY : Removal and Installation"](#).
2. Remove glass mirror. Refer to [MIR-35, "GLASS MIRROR : Removal and Installation"](#).
3. Remove door mirror cover. Refer to [MIR-36, "DOOR MIRROR COVER : Removal and Installation"](#).
4. Remove side camera finisher (1) fixing screw (A).

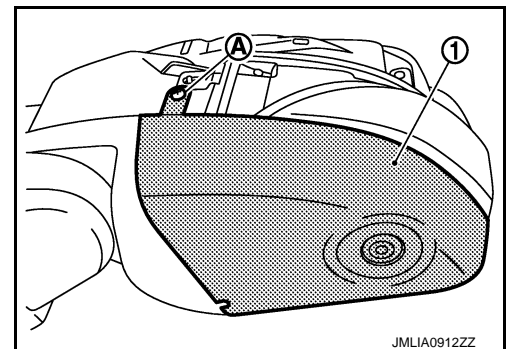

5. Disconnect harness connector (B), and remove screws (C) and pawl (D) fixing the side camera finisher (1) to housing.

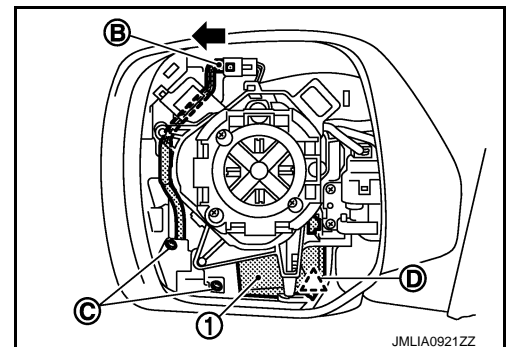

OUTSIDE MIRROR

< REMOVAL AND INSTALLATION >

6. Remove side turn signal lamp fixing screws (E) and remove side turn signal lamp.

NOTE:

Pull slightly side camera finisher (1) covering side turn signal lamp bottom screw.

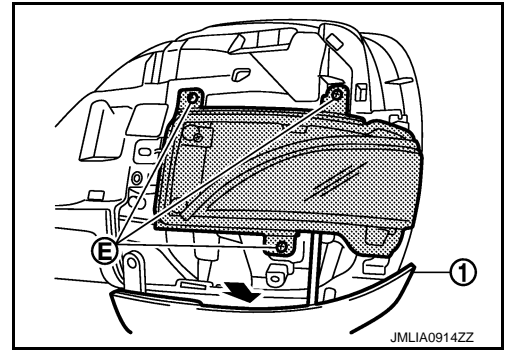

7. Remove side camera finisher assembly.
8. Remove around view camera. Refer to [AV-233, "Removal and Installation"](#).

Assembly

Assemble in the reverse order of disassembly.

A
B
C
D
E
F
G
H
I
J
K
L
M
N
O
P

MIR

DOOR MIRROR REMOTE CONTROL SWITCH

< REMOVAL AND INSTALLATION >

DOOR MIRROR REMOTE CONTROL SWITCH

Removal and Installation

INFOID:000000006257242

REMOVAL

1. Remove the instrument lower panel LH. Refer to [IP-14. "Removal and Installation"](#).
2. Remove the screws (A).

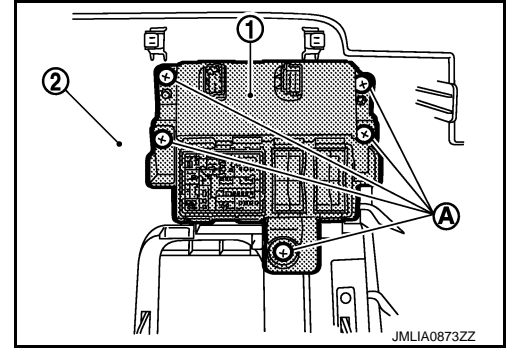

3. Remove the door mirror remote control switch (1) from instrument lower panel LH (2).

INSTALLATION

Install in the reverse order of removal.