

SECTION **SCS**

SUSPENSION CONTROL SYSTEM

A
B
C
D

SCS

CONTENTS

| | | |
|--|---|----------|
| | | |
| HBMC | | |
| PRECAUTION | CHECK SYSTEM PRESSURE | F |
| 4 | Work Procedure | 15 |
| PRECAUTIONS | PRESSURE REDUCING METHOD | G |
| 4 | Work Procedure | 17 |
| Precaution for Supplemental Restraint System (SRS) "AIR BAG" and "SEAT BELT PRE-TEN- SIONER" | AIR BLEEDING METHOD | H |
| 4 | Work Procedure | 18 |
| Precaution Necessary for Steering Wheel Rota- tion after Battery Disconnect | CHECK INTERNAL LEAKAGE | I |
| 4 | Work Procedure | 20 |
| Precaution for Procedure without Cowl Top Cover..... | CHECK FOR MALFUNCTION | J |
| 5 | Work Procedure | 22 |
| Precaution for Hydraulic Body-Motion Control System | CHECK SHOCK ABSORBER FOR MAL- FUNCTION | K |
| 5 | Work Procedure | 24 |
| PREPARATION | CHECK ORIFICE FOR CLOGGING | L |
| 6 | Work Procedure | 27 |
| PREPARATION | SYMPTOM DIAGNOSIS | M |
| 6 | 29 | |
| Special Service Tools | DIFFERENCE IN APPEARANCE | N |
| 6 | Description | 29 |
| Commercial Service Tools | Inspection Procedure | 29 |
| 6 | LARGE ROLL ANGLE | O |
| SYSTEM DESCRIPTION | Description | 30 |
| 7 | Inspection Procedure | 30 |
| DESCRIPTION | REMOVAL AND INSTALLATION | P |
| 7 | 31 | |
| Description | HYDRAULIC BODY-MOTION CONTROL SYSTEM | 31 |
| 7 | Hydraulic Piping | 31 |
| COMPONENT PARTS | FRONT TUBE ASSEMBLY | 31 |
| 8 | FRONT TUBE ASSEMBLY : Exploded View | 32 |
| Component Parts Location | FRONT TUBE ASSEMBLY : Removal and Instal- lation | 32 |
| 8 | FRONT TUBE ASSEMBLY : Inspection | 34 |
| Component Description | | |
| 8 | | |
| STRUCTURE AND OPERATION | | |
| 9 | | |
| Hydraulic Body-Motion Control System | | |
| 9 | | |
| Shock Absorber | | |
| 9 | | |
| PPMU | | |
| 10 | | |
| Accumulator | | |
| 11 | | |
| PPMU Pipe | | |
| 11 | | |
| SYSTEM | | |
| 12 | | |
| System Diagram | | |
| 12 | | |
| System Description | | |
| 12 | | |
| Component Description | | |
| 14 | | |
| BASIC INSPECTION | | |
| 15 | | |

| | | | |
|---|-----------|--|-----------|
| ACCUMULATOR | 34 | ECU DIAGNOSIS INFORMATION | 58 |
| ACCUMULATOR : Exploded View | 35 | AIR LEVELIZER CONTROL MODULE | 58 |
| ACCUMULATOR : Removal and Installation | 35 | Reference Value | 58 |
| ACCUMULATOR : Inspection | 38 | Fail-safe | 59 |
| ACCUMULATOR : Disposal | 38 | DTC Inspection Priority Chart | 59 |
| PPMU, MIDDLE TUBE ASSEMBLY, PPMU PIPE ... | 38 | DTC Index | 59 |
| PPMU, MIDDLE TUBE ASSEMBLY, PPMU PIPE | | WIRING DIAGRAM | 61 |
| : Exploded View | 39 | AIR LEVELIZER CONTROL SYSTEM | 61 |
| PPMU, MIDDLE TUBE ASSEMBLY, PPMU PIPE | | Wiring Diagram | 61 |
| : Removal and Installation | 39 | BASIC INSPECTION | 65 |
| PPMU, MIDDLE TUBE ASSEMBLY, PPMU PIPE | | DIAGNOSIS AND REPAIR WORKFLOW | 65 |
| : Inspection | 43 | Work Flow | 65 |
| PPMU, MIDDLE TUBE ASSEMBLY, PPMU PIPE | | Diagnostic Work Sheet | 66 |
| : Disposal | 43 | STANDARD VEHICLE HEIGHT SETTING | 67 |
| REAR TUBE ASSEMBLY | 43 | Description | 67 |
| REAR TUBE ASSEMBLY : Exploded View | 44 | Work Procedure | 67 |
| REAR TUBE ASSEMBLY : Removal and Installa- | | DTC/CIRCUIT DIAGNOSIS | 69 |
| tion | 44 | C1801 VHCL HEIGHT SENSOR | 69 |
| REAR TUBE ASSEMBLY : Inspection | 46 | DTC Logic | 69 |
| AIR LEVELIZER CONTROL SYSTEM | | Diagnosis Procedure | 69 |
| PRECAUTION | 47 | Component Inspection | 70 |
| PRECAUTIONS | 47 | C1802 AIR SUS COMPRS RELAY | 72 |
| Precaution for Supplemental Restraint System | | DTC Logic | 72 |
| (SRS) "AIR BAG" and "SEAT BELT PRE-TEN- | | Diagnosis Procedure | 72 |
| SIONER" | 47 | C1803 AIR SUSPENSION EXH SOL | 74 |
| Precaution Necessary for Steering Wheel Rota- | | DTC Logic | 74 |
| tion after Battery Disconnect | 47 | Diagnosis Procedure | 74 |
| Precaution for Procedure without Cowl Top Cover.. | | Component Inspection | 75 |
| Precaution for Air Levelizer Control System | 48 | C1804 VHCL HEIGHT ADJ UP | 77 |
| SYSTEM DESCRIPTION | 49 | DTC Logic | 77 |
| DESCRIPTION | 49 | Diagnosis Procedure | 77 |
| Description | 49 | Component Inspection (Air Compressor Relay) | 79 |
| COMPONENT PARTS | 50 | Component Inspection (Air Compressor) | 79 |
| Component Parts Location | 50 | C1805 VHCL HEIGHT ADJ DOWN | 80 |
| Component Description | 50 | DTC Logic | 80 |
| Air Levelizer Control Module | 51 | Diagnosis Procedure | 80 |
| Vehicle Height Sensor | 51 | C1806 VHCL HEIGHT SEN FIX | 81 |
| Air Compressor | 51 | DTC Logic | 81 |
| Air Compressor Relay | 51 | Diagnosis Procedure | 81 |
| CK SUSP Indicator Lamp | 51 | C1807 VHCL HEIGHT SEN VOLT | 82 |
| STRUCTURE AND OPERATION | 52 | DTC Logic | 82 |
| Rear Shock Absorber | 52 | Diagnosis Procedure | 82 |
| Vehicle Height Sensor | 53 | C1808 AIR SUS COMPRS FNCTN | 84 |
| SYSTEM | 54 | DTC Logic | 84 |
| System Diagram | 54 | Diagnosis Procedure | 84 |
| System Description | 54 | U1000 CAN COMM CIRCUIT | 87 |
| Fail-safe | 55 | | |
| DIAGNOSIS SYSTEM (AIR LEVELIZER | | | |
| CONTROL MODULE) | 56 | | |
| CONSULT-III Function | 56 | | |

| | | | | |
|---|-----------|---|-----------|------------|
| Description | 87 | Diagnosis Procedure | 92 | |
| DTC Logic | 87 | CK SUSP INDICATOR LAMP DOES NOT | | A |
| Diagnosis Procedure | 87 | TURN OFF | 93 | |
| U1010 CONTROL UNIT (CAN) | 88 | Description | 93 | B |
| Description | 88 | Diagnosis Procedure | 93 | |
| DTC Logic | 88 | REMOVAL AND INSTALLATION | 94 | C |
| Diagnosis Procedure | 88 | AIR LEVELIZER CONTROL MODULE | 94 | |
| POWER SUPPLY AND GROUND CIRCUIT | 89 | Exploded View | 94 | D |
| Diagnosis Procedure | 89 | Removal and Installation | 94 | |
| CK SUSP INDICATOR LAMP CIRCUIT | 90 | Adjustment | 94 | D |
| Description | 90 | AIR COMPRESSOR/AIR TUBE | 95 | |
| Component Function Check | 90 | Exploded View | 95 | SCS |
| Diagnosis Procedure | 90 | Removal and Installation | 95 | |
| SYMPTOM DIAGNOSIS | 91 | Inspection | 97 | |
| VEHICLE HEIGHT CANNOT BE RAISED | 91 | VEHICLE HEIGHT SENSOR | 98 | F |
| Description | 91 | Exploded View | 98 | |
| Diagnosis Procedure | 91 | Removal and Installation | 98 | G |
| VEHICLE HEIGHT CANNOT BE LOWERED | 92 | Adjustment | 99 | |
| Description | 92 | | | H |
| | | | | I |
| | | | | J |
| | | | | K |
| | | | | L |
| | | | | M |
| | | | | N |
| | | | | O |
| | | | | P |

< PRECAUTION >

PRECAUTION

PRECAUTIONS

Precaution for Supplemental Restraint System (SRS) "AIR BAG" and "SEAT BELT PRE-TENSIONER"

INFOID:000000006256134

The Supplemental Restraint System such as "AIR BAG" and "SEAT BELT PRE-TENSIONER", used along with a front seat belt, helps to reduce the risk or severity of injury to the driver and front passenger for certain types of collision. This system includes seat belt switch inputs and dual stage front air bag modules. The SRS system uses the seat belt switches to determine the front air bag deployment, and may only deploy one front air bag, depending on the severity of a collision and whether the front occupants are belted or unbelted. Information necessary to service the system safely is included in the "SRS AIR BAG" and "SEAT BELT" of this Service Manual.

WARNING:

- **To avoid rendering the SRS inoperative, which could increase the risk of personal injury or death in the event of a collision that would result in air bag inflation, all maintenance must be performed by an authorized NISSAN/INFINITI dealer.**
- **Improper maintenance, including incorrect removal and installation of the SRS, can lead to personal injury caused by unintentional activation of the system. For removal of Spiral Cable and Air Bag Module, see the "SRS AIR BAG".**
- **Do not use electrical test equipment on any circuit related to the SRS unless instructed to in this Service Manual. SRS wiring harnesses can be identified by yellow and/or orange harnesses or harness connectors.**

PRECAUTIONS WHEN USING POWER TOOLS (AIR OR ELECTRIC) AND HAMMERS

WARNING:

- **When working near the Air Bag Diagnosis Sensor Unit or other Air Bag System sensors with the ignition ON or engine running, DO NOT use air or electric power tools or strike near the sensor(s) with a hammer. Heavy vibration could activate the sensor(s) and deploy the air bag(s), possibly causing serious injury.**
- **When using air or electric power tools or hammers, always switch the ignition OFF, disconnect the battery, and wait at least 3 minutes before performing any service.**

Precaution Necessary for Steering Wheel Rotation after Battery Disconnect

INFOID:000000006256136

NOTE:

- Before removing and installing any control units, first turn the push-button ignition switch to the LOCK position, then disconnect both battery cables.
- After finishing work, confirm that all control unit connectors are connected properly, then re-connect both battery cables.
- Always use CONSULT-III to perform self-diagnosis as a part of each function inspection after finishing work. If a DTC is detected, perform trouble diagnosis according to self-diagnosis results.

For vehicle with steering lock unit, if the battery is disconnected or discharged, the steering wheel will lock and cannot be turned.

If turning the steering wheel is required with the battery disconnected or discharged, follow the operation procedure below before starting the repair operation.

OPERATION PROCEDURE

1. Connect both battery cables.

NOTE:

Supply power using jumper cables if battery is discharged.

2. Turn the push-button ignition switch to ACC position.
(At this time, the steering lock will be released.)
3. Disconnect both battery cables. The steering lock will remain released with both battery cables disconnected and the steering wheel can be turned.
4. Perform the necessary repair operation.

PRECAUTIONS

[HBMC]

< PRECAUTION >

- When the repair work is completed, re-connect both battery cables. With the brake pedal released, turn the push-button ignition switch from ACC position to ON position, then to LOCK position. (The steering wheel will lock when the push-button ignition switch is turned to LOCK position.)
- Perform self-diagnosis check of all control units using CONSULT-III.

Precaution for Procedure without Cowl Top Cover

INFOID:000000006256138

When performing the procedure after removing cowl top cover, cover the lower end of windshield with urethane, etc.

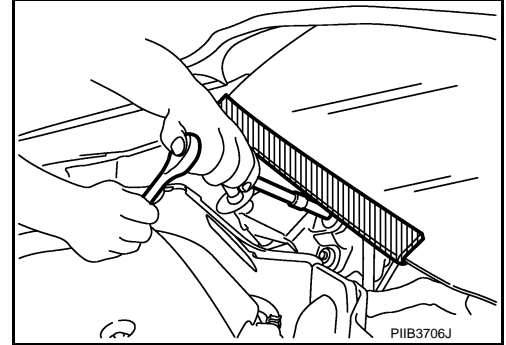

Precaution for Hydraulic Body-Motion Control System

INFOID:000000006255996

WARNING:

- Always check the piping for loose connections, damage, or twists before starting operation, since pressure in hydraulic circuit becomes high during air bleeding operation.
- When repairing or replacing a malfunctioning part, always release pressure from hydraulic circuit, since dangerous conditions may be created when oil leakage occurs during air bleeding operation.
- Clean surrounding areas of oil inlet and air bleeder using steam before starting operation, since there may be mud on it.
- Always decrease pressure when removing a system related part, since system pressure is high.
- Seal the removed part using vinyl tape for preventing dirt from getting on or entering the removed part.
- Check system pressure again 1 day or more after bleeding operation is complete, since system pressure may decrease when air bleeding is insufficient.
- Use Genuine NISSAN Hydraulic Suspension Fluid for suspension fluid.
- Never reuse drained suspension fluid.
- Check for suspension fluid leakage after removing a system-related part.

PREPARATION

[HBMC]

< PREPARATION >

PREPARATION

PREPARATION

Special Service Tools

INFOID:000000006255997

The actual shapes of Kent-Moore tools may differ from those of special service tools illustrated here.

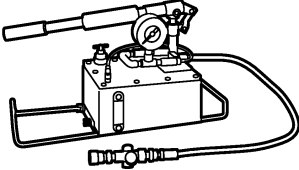
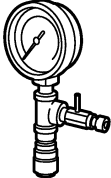
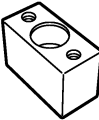
| Tool number (Kent-Moore No.) Tool name | Description |
|--|---|
| KV40107700 (—) Suspension oil pump |  <p style="text-align: center;">JSEIA0183ZZ</p> <ul style="list-style-type: none"> • Air bleeding • System diagnosis |
| KV40108000 (—) Oil pressure gauge |  <p style="text-align: center;">JSEIA0184ZZ</p> <p>System pressure check</p> |
| KV40108400 (—) Leak check plug |  <p style="text-align: center;">JSEIA0185ZZ</p> <p>Shock absorber leakage check</p> |

Commercial Service Tools

INFOID:000000006414888

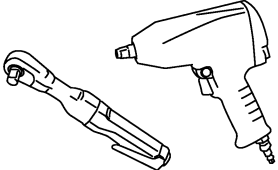
| Tool name | Description |
|------------|--|
| Power tool |  <p style="text-align: center;">PBIC0190E</p> <p>Loosening bolts and nuts</p> |

< SYSTEM DESCRIPTION >

SYSTEM DESCRIPTION

DESCRIPTION

Description

INFOID:000000006255998

- Hydraulic body-motion control system is adopted, which makes shock absorber stroke appropriately by hydraulic pressure according to driving scenes.
- The adoption of this system allows the reduction in a roll angle (i.e. vehicle body tilt angle at cornering) to improve steering stability and ride quality during travel on level roads. Furthermore, the use of this system improves the running performance on rough roads by shock absorption and quality tire adhesion through maximized stroke.

A
B
C
D
F
G
H
I
J
K
L
M
N
O
P

SCS

COMPONENT PARTS

[HBMC]

< SYSTEM DESCRIPTION >

COMPONENT PARTS

Component Parts Location

INFOID:000000006255999

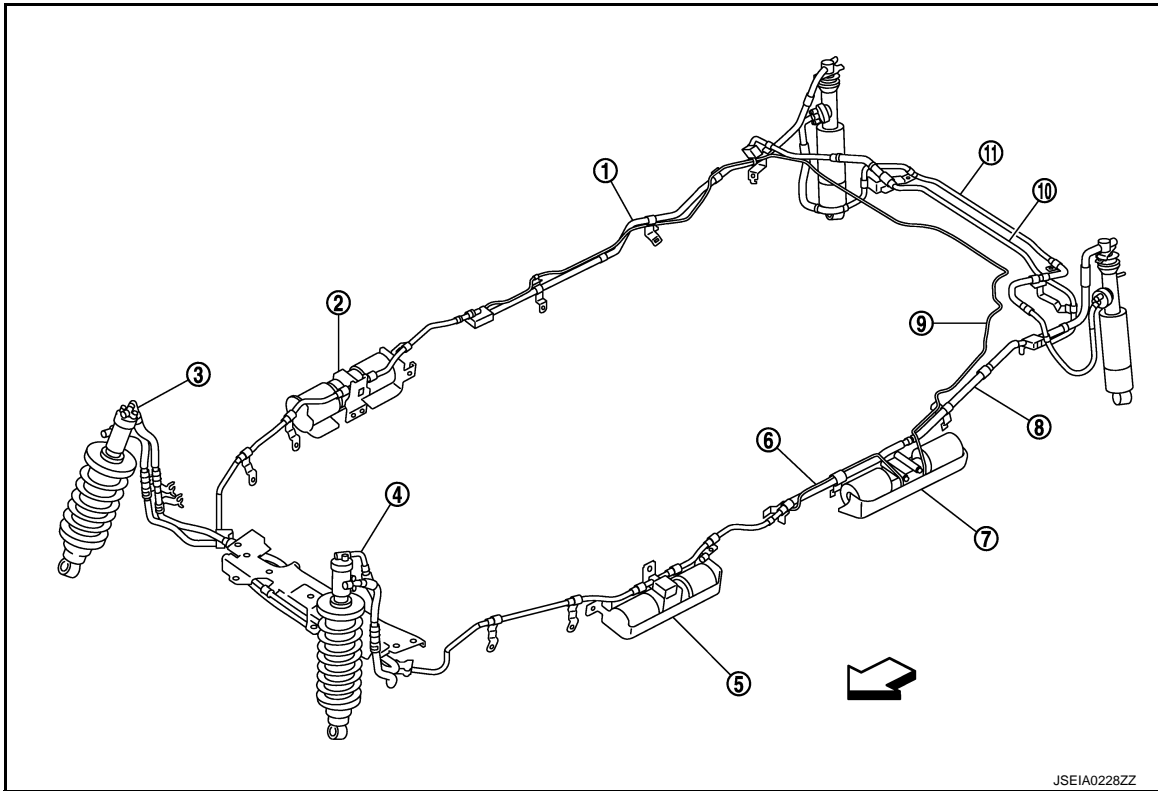

JSEIA0228ZZ

- | | | |
|----------------------------|----------------------------|--------------------------|
| 1. Middle tube assembly RH | 2. Accumulator assembly RH | 3. Front tube assembly A |
| 4. Front tube assembly B | 5. Accumulator assembly LH | 6. PPMU pipe A |
| 7. PPMU assembly | 8. Middle tube assembly LH | 9. PPMU pipe B |
| 10. Rear tube assembly A | 11. Rear tube assembly B | |
- ← Vehicle front

Component Description

INFOID:000000006256000

| Component parts | Reference |
|-----------------|---|
| Shock absorber | SCS-9, "Shock Absorber" |
| Accumulator | SCS-11, "Accumulator" |
| PPMU | SCS-10, "PPMU" |
| PPMU pipe A | SCS-11, "PPMU Pipe" |
| PPMU pipe B | |

STRUCTURE AND OPERATION

Hydraulic Body-Motion Control System

INFOID:000000006256001

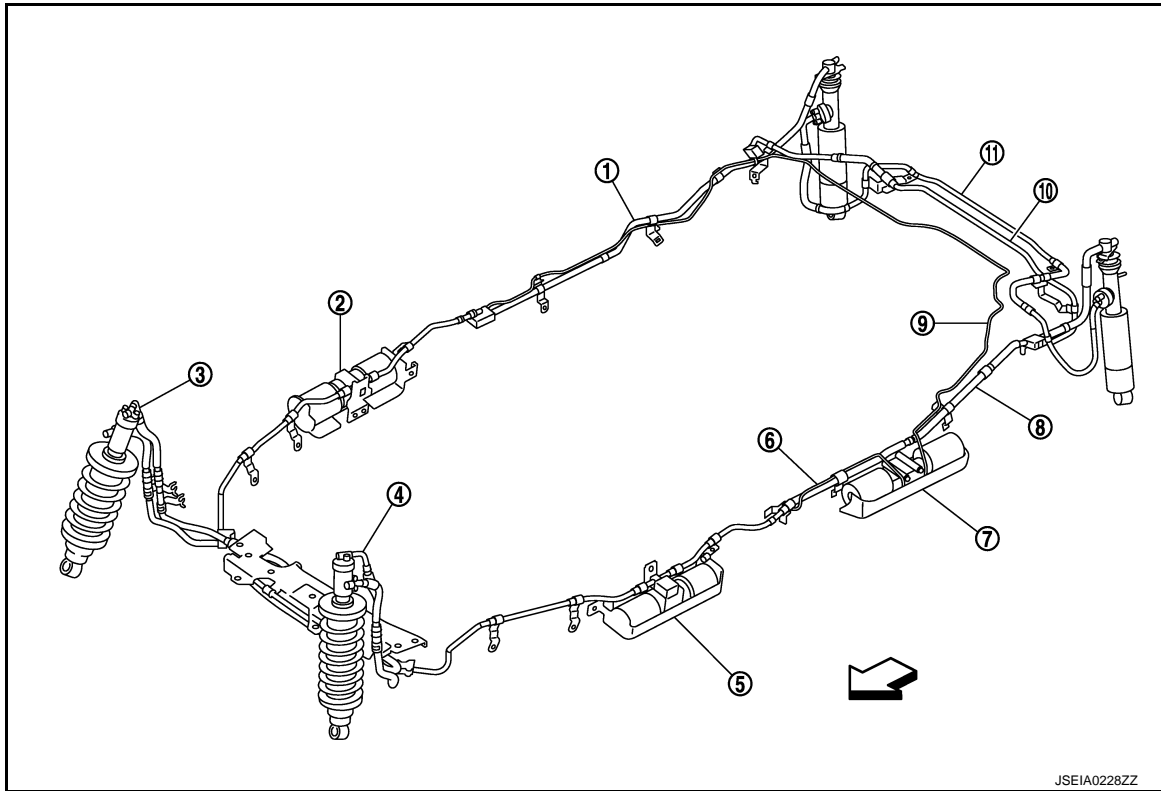

- | | | |
|----------------------------|----------------------------|--------------------------|
| 1. Middle tube assembly RH | 2. Accumulator assembly RH | 3. Front tube assembly A |
| 4. Front tube assembly B | 5. Accumulator assembly LH | 6. PPMU pipe A |
| 7. PPMU assembly | 8. Middle tube assembly LH | 9. PPMU pipe B |
| 10. Rear tube assembly A | 11. Rear tube assembly B | |
- ↔ Vehicle front

Shock Absorber

INFOID:000000006256002

The use of accumulator-generated pressure responsive to driving conditions or pressure generated by oil flow to the upper/lower chamber improves the steering stability at curving, in addition to the running performance and a ride quality during off-road travel.

FRONT SIDE

Oil enters from oil inlet outlet hole (A) and flows into lower chamber (3) via outside oil path of cylinder inside. Oil enters from oil inlet outlet hole (B) and flows into upper chamber (1). With the pressure difference between oil flowed into the upper chamber and lower chamber, the piston (2) moves up and down and conveys a force generated through this motion to the tires.

STRUCTURE AND OPERATION

< SYSTEM DESCRIPTION >

[HBMC]

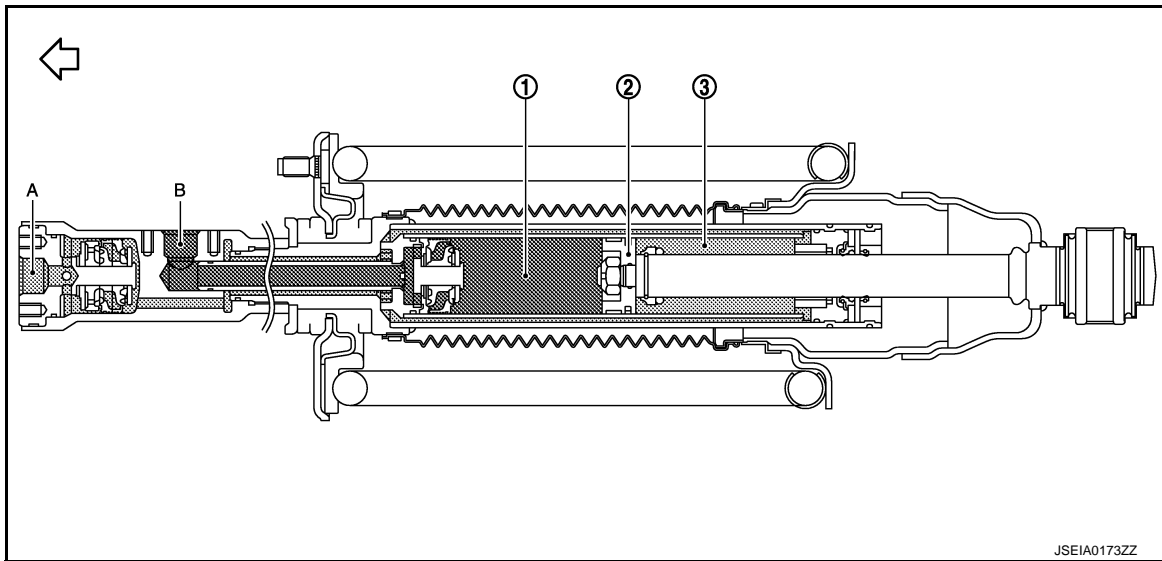

- 1. Upper chamber
- 2. Piston
- 3. Lower chamber
- A. Oil inlet outlet hole
- B. Oil inlet outlet hole
- ←: Vehicle upper

REAR SIDE

Oil enters from oil inlet outlet hole (A) and flows into upper chamber (1). Oil enters from oil inlet outlet hole (B) and flows into lower chamber (3) via outside oil path of cylinder inside. With the pressure difference between oil flowed into the upper chamber and lower chamber, the piston (2) moves up and down and conveys a force generated through this motion to the tires.

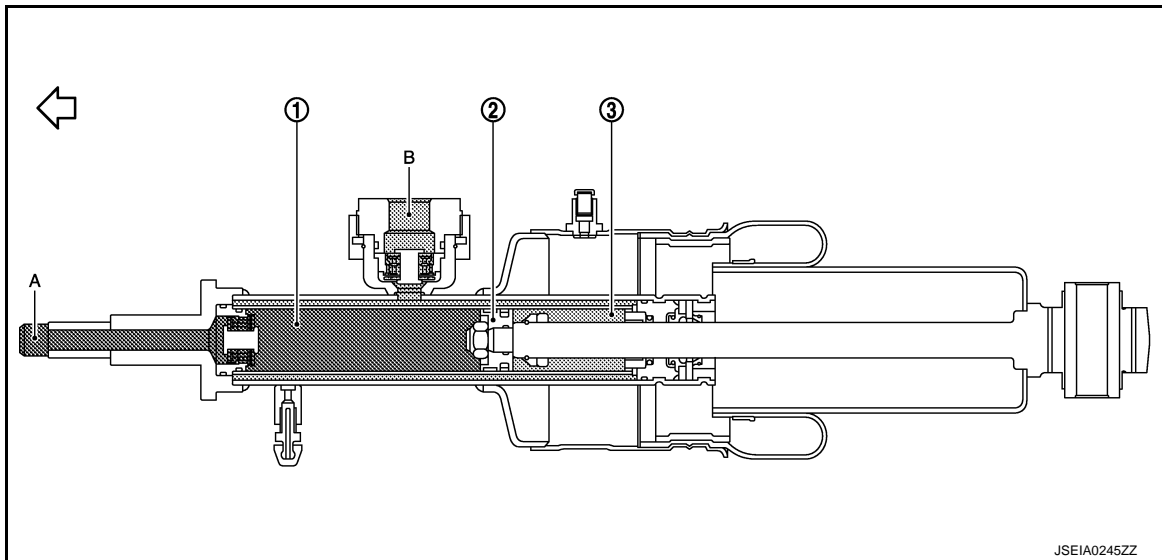

- 1. Upper chamber
- 2. Piston
- 3. Lower chamber
- A. Oil inlet outlet hole
- B. Oil inlet outlet hole
- ←: Vehicle upper

PPMU

INFOID:000000006256003

- PPMU stands for Passive Pressure Maintenance Unit.
- System pressure increases according to increase of oil volume due to oil temperature increase. Sudden rise in system pressure can be controlled by feeding the increased oil into the PPMU.
- Oil flows into oil chamber via PPMU pipe A and PPMU pipe B by influence of pressure change, pushes gas spring of nitrogen gas, and pools.

STRUCTURE AND OPERATION

[HBMC]

< SYSTEM DESCRIPTION >

When system pressure decreases, influent oil is distributed to both pipes by gas spring reaction force of nitrogen gas via PPMU pipe A and PPMU pipe B to control sudden decrease in system pressure.

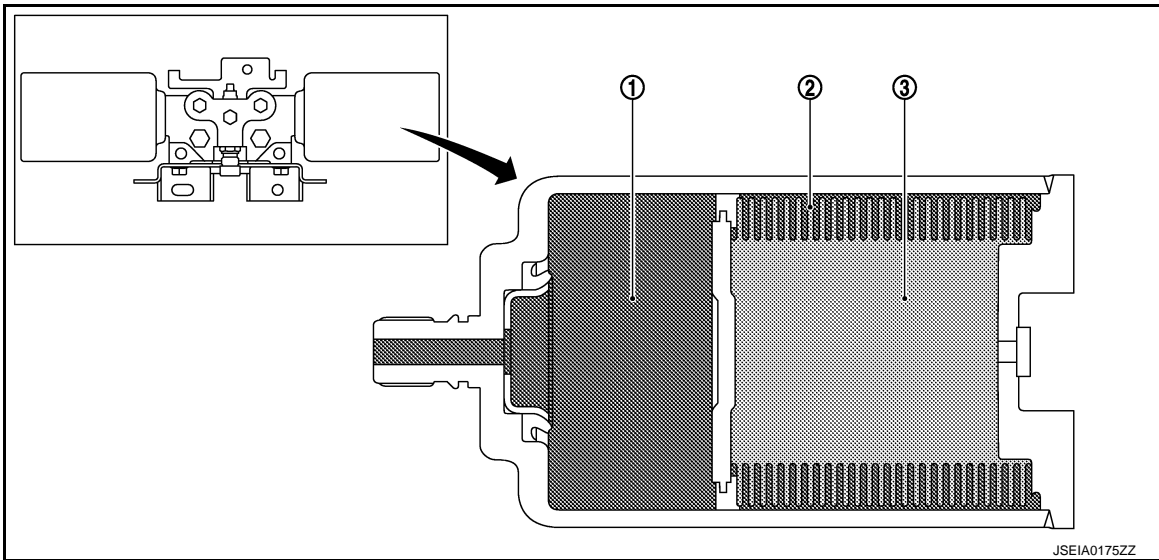

1. Oil chamber

2. Bellows

3. Gas chamber

Accumulator

INFOID:000000006256004

Influent oil from both front and rear shock absorbers on the outer ring flows simultaneously into the oil chamber during cornering, and gas spring reaction force of nitrogen gas increases pressure, according to the influent oil level. As for inner ring side, the gas spring conveys oil from the oil chamber to both front and rear shock absorbers and decreases pressure, according to the oil level.

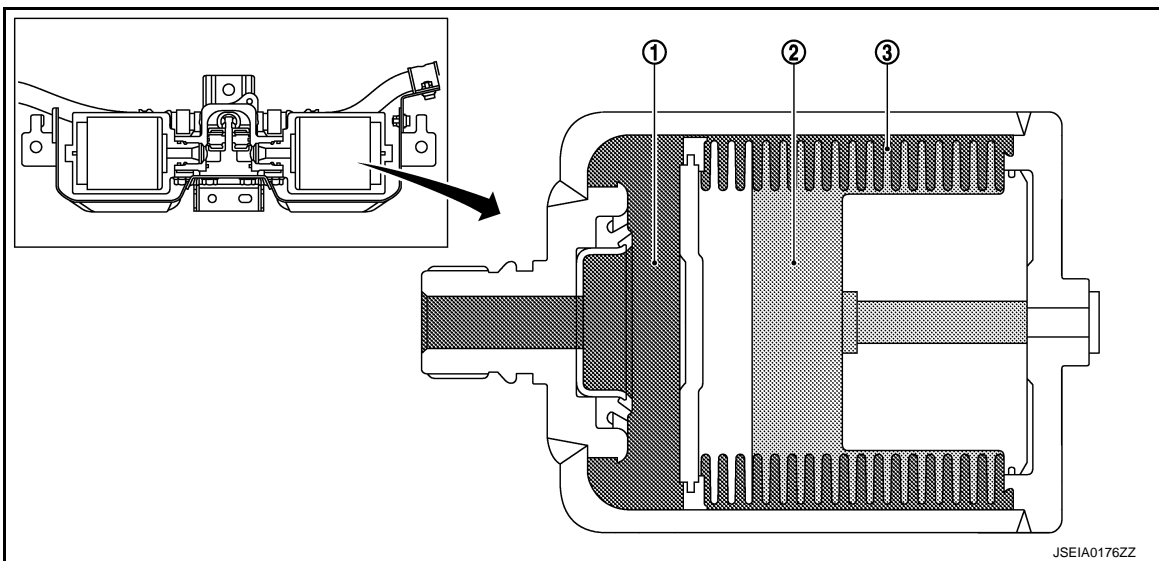

1. Oil chamber

2. Gas chamber

3. Bellows

PPMU Pipe

INFOID:000000006256005

PPMU and right and left tubes are connected. When oil increases according to increase of system pressure, increased amount of oil is sent to PPMU. When system pressure decreases, oil discharged from PPMU is sent to right and left tubes.

SYSTEM

System Diagram

INFOID:000000006256006

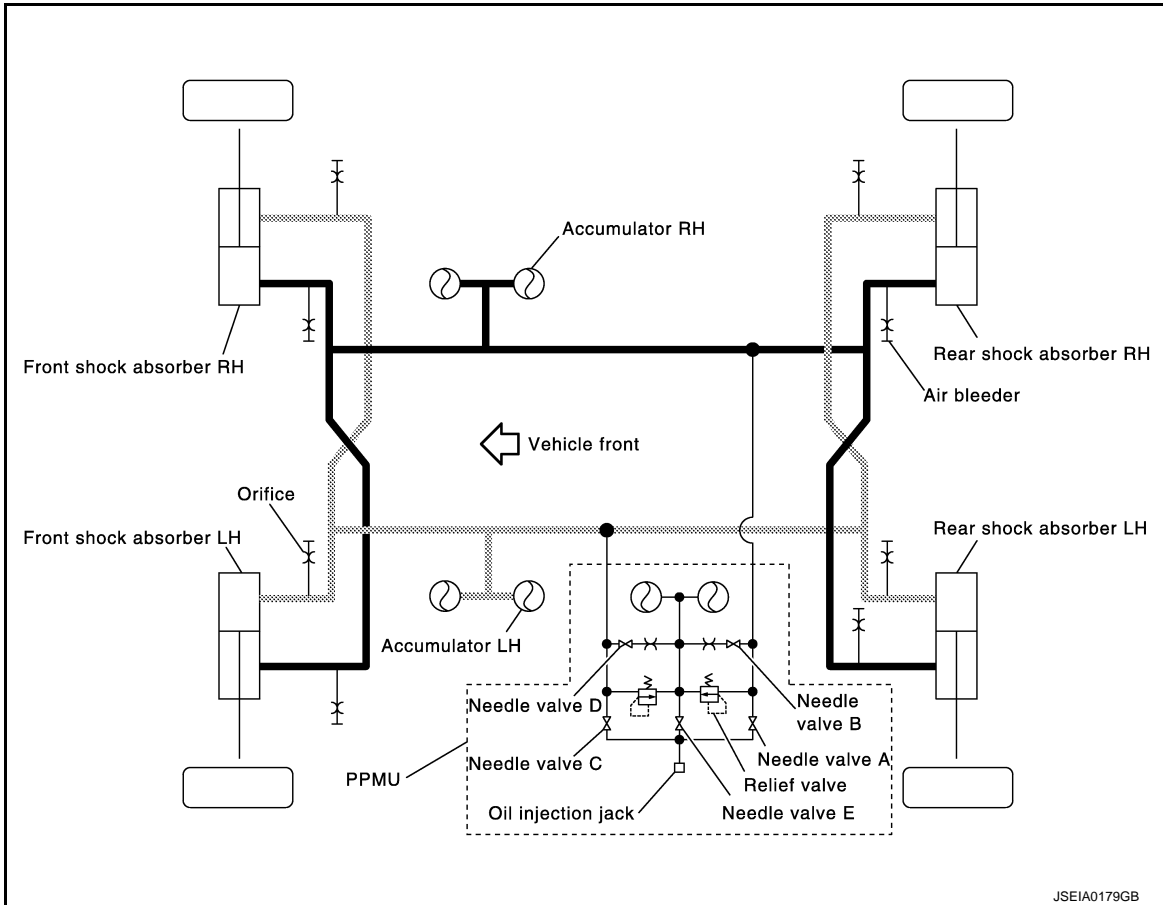

System Description

INFOID:000000006256007

- Drivability during cornering and driving on rough road is improved by mechanically generating oil pressure by connecting 4 units of shock absorbers to front, rear, right, and left by piping lines of 2 systems.
- Oil filling and system diagnosis can be performed using PPMU.

OPERATING PRINCIPLE

During cornering (Front and rear wheels in the outer side of corner: compressing)

When shock absorber in the outer side of corner is compressed during cornering, oil moves along piping path and overflowing oil from piping path flows in accumulator in the outer side of corner. Then, pressure increases by action of gas spring of nitrogen gas according to amount of oil that flows in.

Pressure in the inner side of corner decreases, since oil is discharged from accumulator by stroke (extending direction) of shock absorber.

The pressure difference generates stabilizer-like action to maintain balance in vehicle posture for a steady driving at cornering.

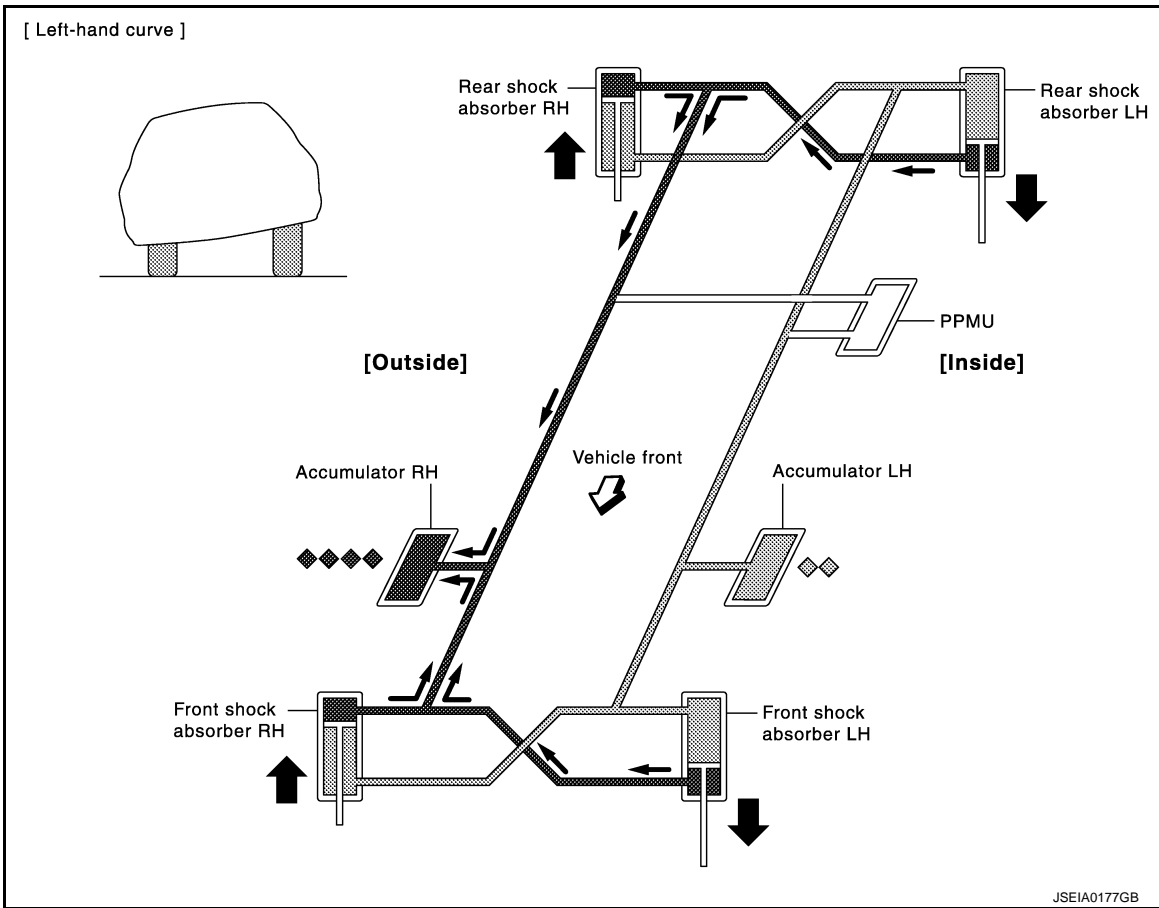

A
B
C
D
SCS
F
G
H
I
J
K
L
M
N
O
P

During rough road driving (Front wheel LH: compressing, front wheel RH: extending, rear wheel LH: extending, rear wheel RH: compressing)

Discharged oil from each shock absorber moves along piping path, but oil does not overflow from piping path, since oil moves in between each shock absorber. Oil does not flow in accumulator and system pressure does not increase.

Since the oil from the contracted shock absorber flows into the shock absorber upper chamber, stabilizer-like action is not generated. This improves the adhesion level and the running performance on rough roads.

SYSTEM

< SYSTEM DESCRIPTION >

[HBMC]

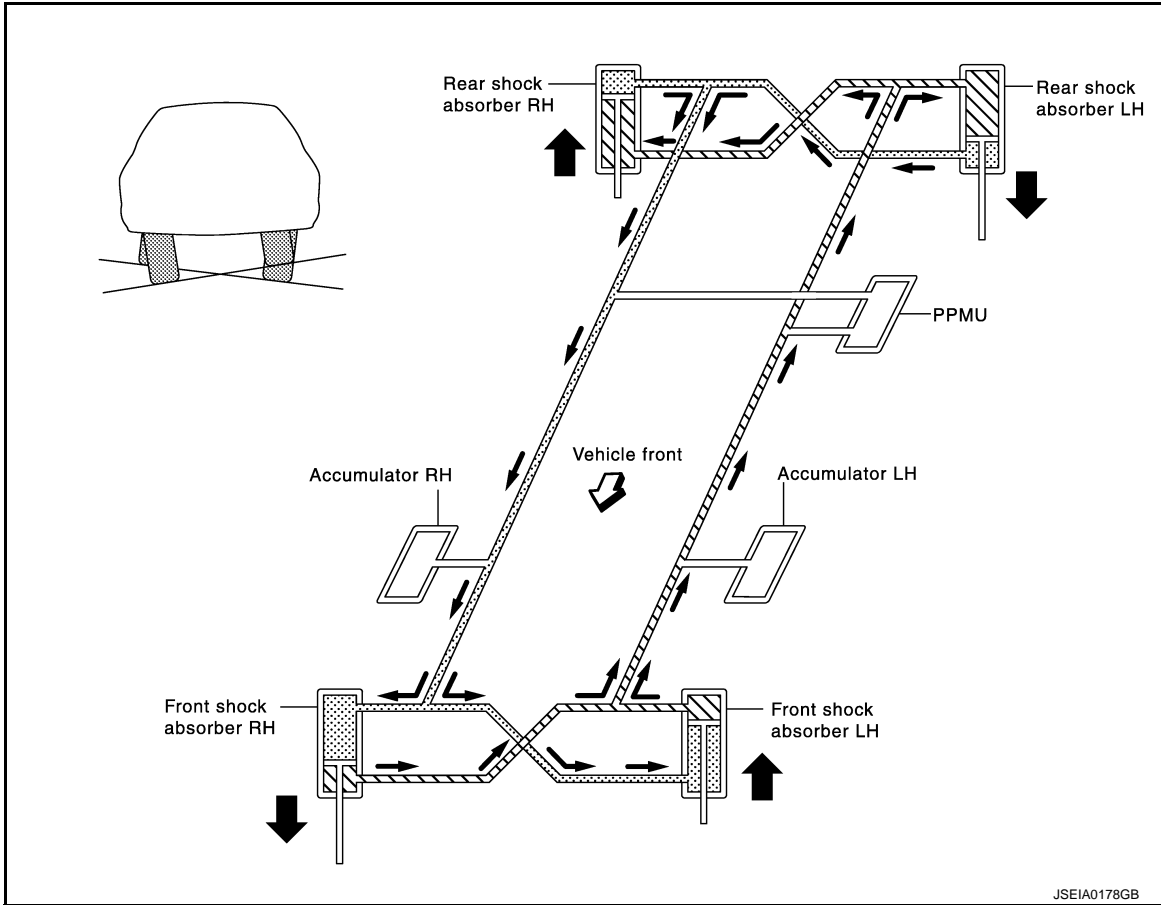

Component Description

INFOID:000000006256008

| Component parts | Description |
|--------------------|--|
| Needle valve A | Needle valve for oil filling or trouble diagnosis. It is usually closed. |
| Needle valve B | Needle valve for trouble diagnosis. It is usually open. |
| Needle valve C | Needle valve for oil filling or trouble diagnosis. It is usually closed. |
| Needle valve D | Needle valve for trouble diagnosis. It is usually open. |
| Needle valve E | Needle valve for oil filling or trouble diagnosis. It is usually closed. |
| Relief valve | If system pressure increases, then the orifice becomes clogged and oil flow into PPMU becomes disrupted, resulting in a large pressure difference between PPMU and both pipes. In this case, the relief valve opens to let the oil flow. |
| Oil injection jack | <ul style="list-style-type: none"> Oil filling inlet For basic inspection use. |
| Air bleeder | For air bleeding use. |

CHECK SYSTEM PRESSURE

[HBMC]

< BASIC INSPECTION >

BASIC INSPECTION

CHECK SYSTEM PRESSURE

Work Procedure

INFOID:000000006256009

CAUTION:

- Clean surrounding areas of oil injection jack using steam before starting operation, since there may be mud on it.
- Clean oil pressure gauge (special service tool: KV40108000) jack with steam before use.

1. Lift up the vehicle.
2. Remove protector of PPMU.
3. Remove cap of oil injection jack.
4. Install an oil pressure gauge (SST: KV40108000) (A) to oil injection jack.

CAUTION:

- Jack must be securely inserted until a click sound can be heard.
- Pressure reducing valve (B) of the oil pressure gauge must be closed.

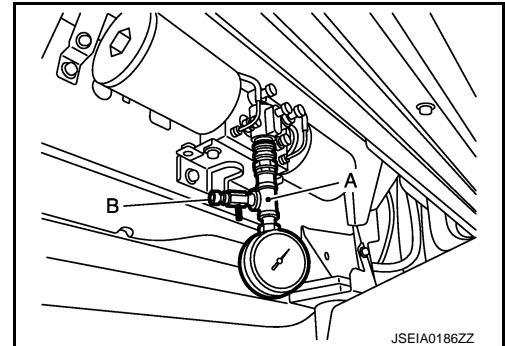

5. Loosen needle valves A, C, and E of PPMU by approximately 2 rotations.

CAUTION:

Never loosen the needle valve more than required.

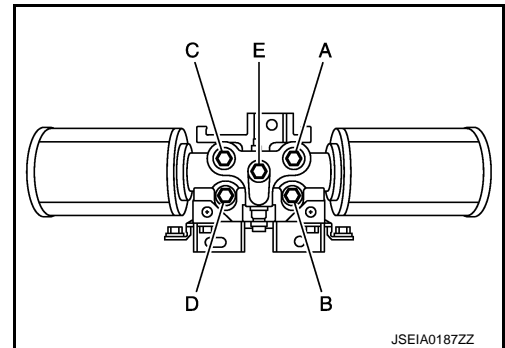

6. Refer to the figure and check the specified pressure.
7. Tighten needle valves A, C, and E of PPMU to the specified torque.

Tightening torque : 8.3 N·m (0.85 kg·m, 73 in·lb)

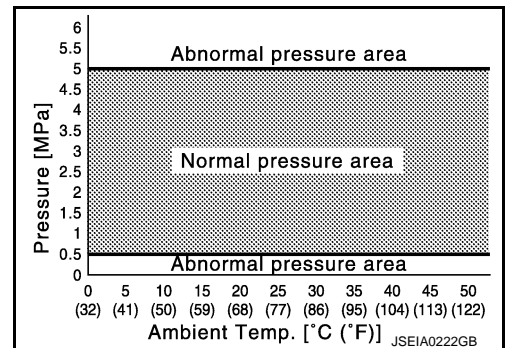

CHECK SYSTEM PRESSURE

[HBMC]

< BASIC INSPECTION >

- Loosen pressure reducing valve (A) of oil pressure gauge and then lower pressure.

CAUTION:

Be careful since oil drains swiftly from oil drain hole (B).

- Check that reading of oil pressure gauge is 0 MPa.
- Remove oil pressure gauge.
- Install cap of oil injection jack.
- Install protector of PPMU. Refer to [SCS-39, "PPMU, MIDDLE TUBE ASSEMBLY, PPMU PIPE : Exploded View"](#).

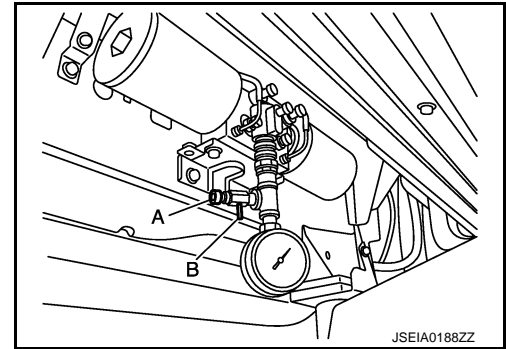

PRESSURE REDUCING METHOD

Work Procedure

INFOID:000000006256010

CAUTION:

- Clean surrounding areas of oil injection jack using steam before starting operation, since there may be mud on it.
- Clean oil pressure gauge (special service tool: KV40108000) jack with steam before use.

1. Lift up the vehicle.
2. Remove protector of PPMU.
3. Remove cap of oil injection jack.
4. Install an oil pressure gauge (SST: KV40108000) (A) to oil injection jack.

CAUTION:

- Jack must be securely inserted until a click sound can be heard.
- Pressure reducing valve (B) of the oil pressure gauge must be closed.

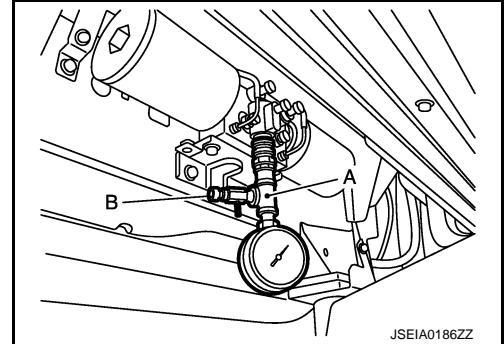

5. Loosen needle valves A, C, and E of PPMU by approximately 2 rotations.

CAUTION:

Never loosen the needle valve more than required.

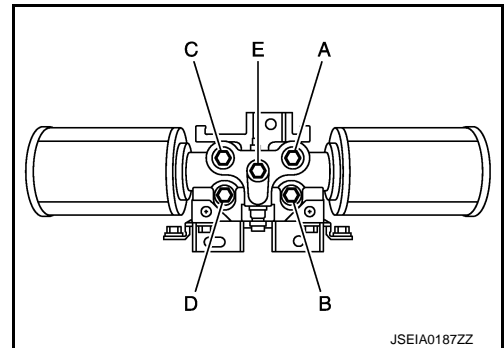

6. Loosen pressure reducing valve (A) of oil pressure gauge and then lower pressure.

CAUTION:

Be careful since oil drains swiftly from oil drain hole (B).

7. Check that reading of oil pressure gauge is 0 MPa.
8. Tighten needle valves A, C, and E of PPMU to the specified torque.

Tightening torque : 8.3 N·m (0.85 kg-m, 73 in-lb)

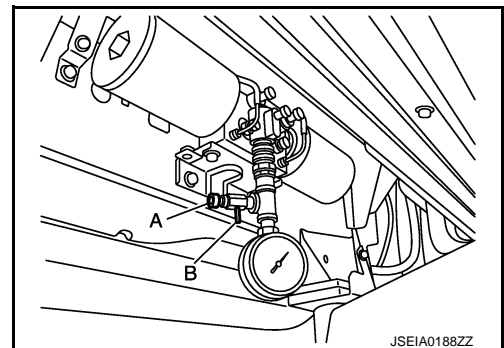

A
B
C
D
SCS
F
G
H
I
J
K
L
M
N
O
P

AIR BLEEDING METHOD

< BASIC INSPECTION >

[HBMC]

AIR BLEEDING METHOD

Work Procedure

INFOID:000000006256011

WARNING:

- Always check the piping for loose connections, damage, or twists before starting operation, since pressure in hydraulic circuit becomes high during operation.
- When repairing or replacing a malfunctioning part, always release pressure from hydraulic circuit, since dangerous conditions may be created when oil leakage occurs during air bleeding operation.

CAUTION:

- Clean surrounding areas of oil injection jack and air bleeder using steam before starting operation, since there may be mud on it.
- Clean suspension oil pump (special service tool: KV40107700) jack with steam before use.
- Check system pressure again 1 day or more after bleeding operation is complete, since system pressure may decrease when air bleeding is insufficient.

1. Lift up the vehicle.
2. Remove protector of PPMU.
3. Remove cap of oil injection jack.
4. Install hose (A) of a suspension oil pump (SST: KV40107700) to oil injection jack.

CAUTION:

Jack must be securely inserted until a click sound can be heard.

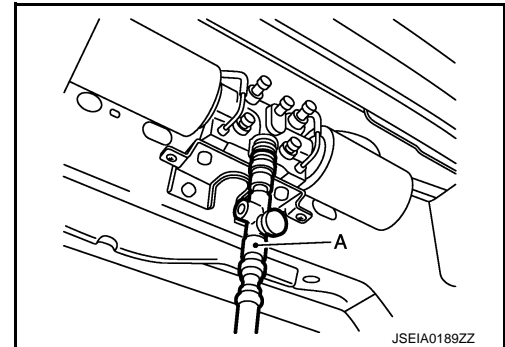

5. Loosen pressure reducing valve (A) of hose portion of suspension oil pump.

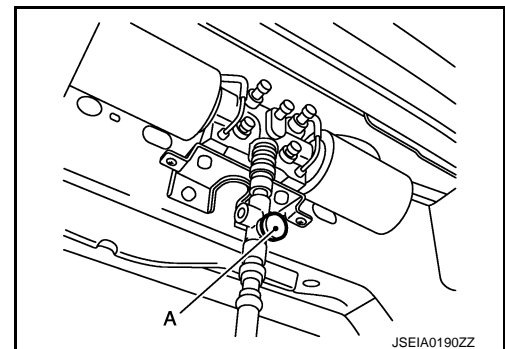

6. Set knob (A) of suspension oil pump to the direction as shown in the figure.
7. Close pressure reducing valve of hose portion of suspension oil pump while sending oil by applying pressure using suspension oil pump. (Air bleeding in hose is complete.)

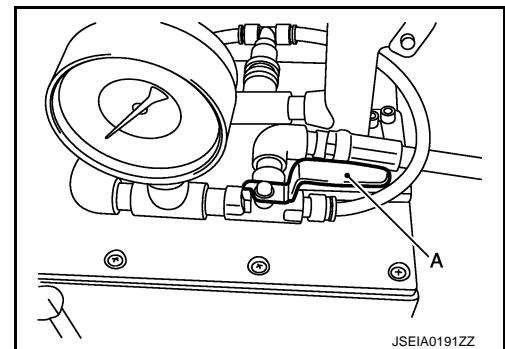

AIR BLEEDING METHOD

[HBMC]

< BASIC INSPECTION >

- Loosen needle valves A, C, and E of PPMU by approximately 2 rotations.

CAUTION:

Never loosen the needle valve more than required.

- Install bleeder tube and drain tank to bleeder valve in upper side of rear shock absorber RH.
- Loosen bleeder valve and bleed air while sending oil by applying pressure using suspension oil pump, and then quickly tighten air bleeder.

CAUTION:

Be careful that oil in suspension oil pump is not at half or less.

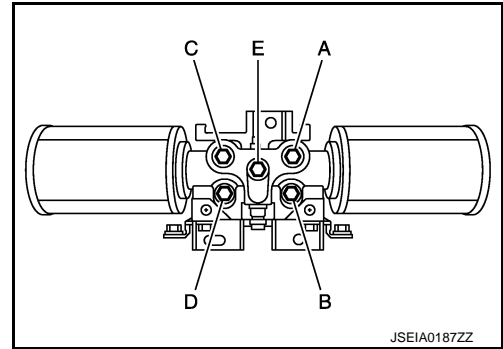

- Repeat step 10 until no air appears in bleeder tube.
- Tighten bleeder valve to the specified torque. Refer to [SCS-32, "FRONT TUBE ASSEMBLY : Exploded View"](#) (front shock absorber), [SCS-39, "PPMU, MIDDLE TUBE ASSEMBLY, PPMU PIPE : Exploded View"](#) (upper side of rear shock absorber).

Lower side of rear shock absorber

Tightening torque : 8.3 N-m (0.85 kg-m, 73 in-lb)

- Perform operation according to steps 9 to 12 in the order of rear shock absorber RH (lower side) → front shock absorber RH (upper side and lower side) → rear shock absorber LH (upper side and lower side) → front shock absorber LH (upper side and lower side).
- Repeat steps 9 to 13 (2nd turn).
- Refer to the figure and send oil by applying pressure.

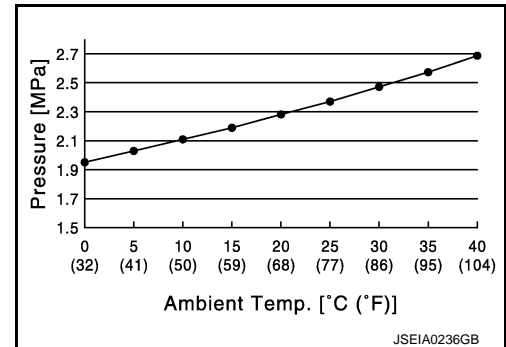

- Tighten needle valves A, C, and E of PPMU to the specified torque.

Tightening torque : 8.3 N-m (0.85 kg-m, 73 in-lb)

- Set knob (A) of suspension oil pump to the direction as shown in the figure and check that reading of pressure gauge is 0 MPa.
- Remove hose of suspension oil pump.
- Install cap of oil injection jack.
- Install protector of PPMU. Refer to [SCS-39, "PPMU, MIDDLE TUBE ASSEMBLY, PPMU PIPE : Exploded View"](#).

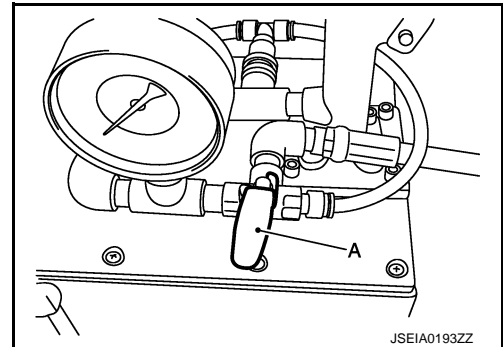

CHECK INTERNAL LEAKAGE

[HBMC]

< BASIC INSPECTION >

CHECK INTERNAL LEAKAGE

Work Procedure

INFOID:000000006256012

CAUTION:

- Clean surrounding areas of oil injection jack using steam before starting operation, since there may be mud on it.
- Clean oil pressure gauge (special service tool: KV40108000) jack with steam before use.

1. Remove protector of PPMU.
2. Remove cap of oil injection jack.
3. Install an oil pressure gauge (SST: KV40108000) (A) to oil injection jack.

CAUTION:

- Jack must be securely inserted until a click sound can be heard.
- Pressure reducing valve (B) of the oil pressure gauge must be closed.

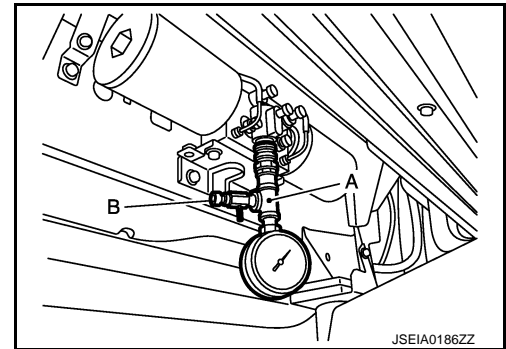

4. Loosen needle valves A, C, and E of PPMU by approximately 2 rotations.

CAUTION:

Never loosen the needle valve more than required.

5. Lift up the vehicle.

CAUTION:

Check that tires never contact the ground.

6. Tighten needle valves C and E of PPMU.
7. Loosen lock nut of needle valve D of PPMU and then tighten needle valve D.
8. Lift down the vehicle.

CAUTION:

Check that the lift is fully lowered.

9. Write down a value of the oil pressure gauge after 5 minutes.
10. Tighten needle valve A of PPMU.
11. Loosen lock nut of needle valve B of PPMU and then tighten needle valve B.
12. Loosen needle valve C of PPMU by approximately 2 rotations.

CAUTION:

Never loosen the needle valve more than required.

13. Read a value of oil pressure gauge.
14. Compare difference of reading with pressure reading in step 9.

Pressure difference

0.1 MPa or more : Normal

0.1 MPa or less : Malfunction

15. Tighten needle valves A, C, and E of PPMU to the specified torque.

 : 8.3 N·m (0.85 kg·m, 73 in·lb)

16. Loosen needle valves B and D of PPMU by approximately 2 rotations and then tighten lock nut to the specified torque.

CAUTION:

Never loosen the needle valve more than required.

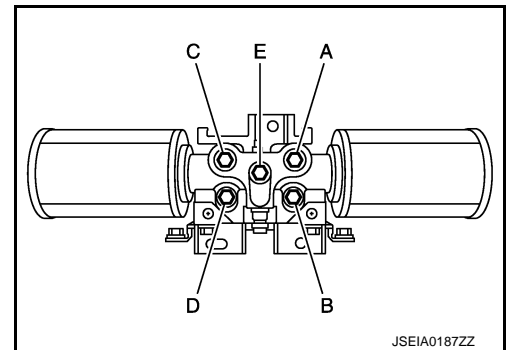

CHECK INTERNAL LEAKAGE

< BASIC INSPECTION >

[HBMC]

 : 20 N·m (2.0 kg-m, 15 ft-lb)

17. Loosen pressure reducing valve (A) of oil pressure gauge and lower pressure.

CAUTION:

Be careful since oil drains swiftly from oil drain hole (B).

18. Check that reading of oil pressure gauge is 0 MPa.
19. Remove oil pressure gauge.

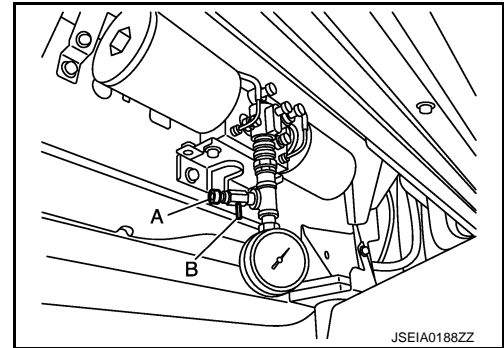

A
B
C
D

SCS

F
G
H
I
J
K
L
M
N
O
P

CHECK FOR MALFUNCTION

[HBMC]

< BASIC INSPECTION >

CHECK FOR MALFUNCTION

Work Procedure

INFOID:000000006256013

CAUTION:

- Clean surrounding areas of oil injection jack using steam before starting operation, since there may be mud on it.
- Clean oil pressure gauge (special service tool: KV40108000) jack with steam before use.

1. Remove protector of PPMU.
2. Remove cap of oil injection jack.
3. Install an oil pressure gauge (SST: KV40108000) (A) to oil injection jack.

CAUTION:

- Jack must be securely inserted until a click sound can be heard.
- Pressure reducing valve (B) of the oil pressure gauge must be closed.

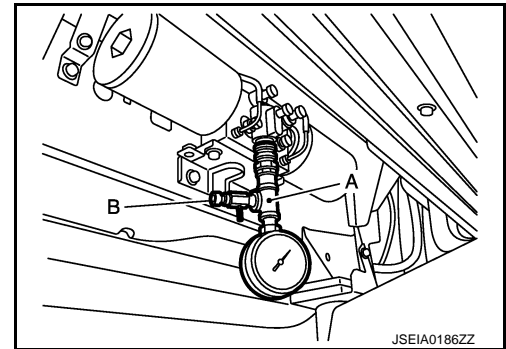

4. Loosen needle valves A, C, and E of PPMU by approximately 2 rotations.

CAUTION:

Never loosen the needle valve more than required.

5. Lift up the vehicle.

CAUTION:

Check that tires never contact the ground.

6. Tighten needle valves A and C of PPMU.
7. Loosen lock nuts of needle valves B and D of PPMU and then tighten needle valves B and D.
8. Write down a value of the oil pressure gauge.
9. Lift down the vehicle.

CAUTION:

Check that the lift is fully lowered.

10. Read a value of oil pressure gauge.
11. Compare difference of reading with pressure reading in step 8.

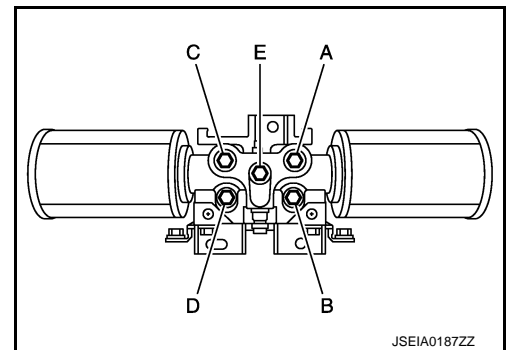

Pressure change

Pressure increases : PPMU malfunction

Pressure does not change : Shock absorber malfunction

12. Tighten needle valves A, C, and E of PPMU to the specified torque.

Tightening torque : 8.3 N·m (0.85 kg-m, 73 in-lb)

13. Loosen needle valves B and D of PPMU by approximately 2 rotations and then tighten lock nut to the specified torque.

CAUTION:

Never loosen the needle valve more than required.

Tightening torque : 20 N·m (2.0 kg-m, 15 ft-lb)

CHECK FOR MALFUNCTION

[HBMC]

< BASIC INSPECTION >

- Loosen pressure reducing valve (A) of oil pressure gauge and then lower pressure.

CAUTION:

Be careful since oil drains swiftly from oil drain hole (B).

- Check that reading of oil pressure gauge is 0 MPa.
- Remove oil pressure gauge.

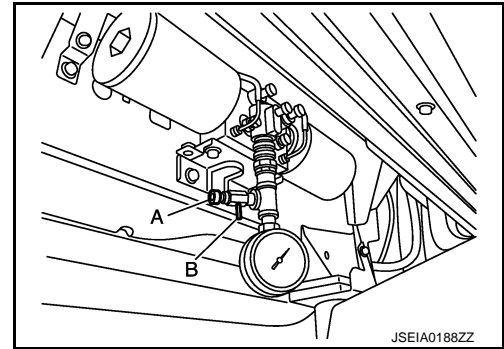

A
B
C
D

SCS

F
G
H
I
J
K
L
M
N
O
P

CHECK SHOCK ABSORBER FOR MALFUNCTION

[HBMC]

< BASIC INSPECTION >

CHECK SHOCK ABSORBER FOR MALFUNCTION

Work Procedure

INFOID:000000006256014

CAUTION:

- Clean surrounding areas of oil injection jack using steam before starting operation, since there may be mud on it.
- Clean suspension oil pump (special service tool: KV40107700) jack with steam before use.
- Clean leak check plug (special service tool: KV40108400) jack with steam before use.
- Check each shock absorber, one by one, in accordance with the following procedures.

1. Lift up the vehicle.
2. Remove protector of PPMU.
3. Remove cap of oil injection jack.
4. Install hose (A) of a suspension oil pump (SST: KV40107700) to oil injection jack.

CAUTION:

- Jack must be securely inserted until a click sound can be heard.
- Pressure reducing valve (B) of the suspension oil pump must be closed.

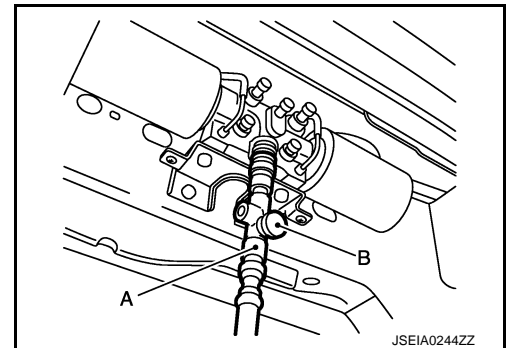

5. Loosen needle valves A, C, and E of PPMU by approximately 2 rotations.

CAUTION:

Never loosen the needle valve more than required.

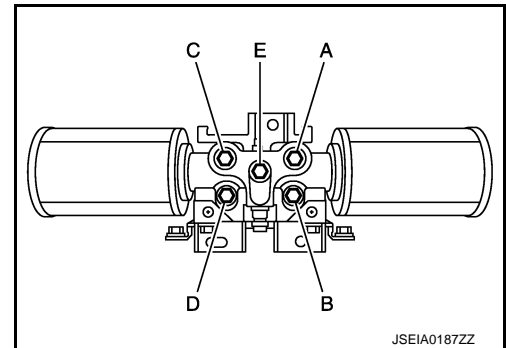

6. Set knob (A) of suspension oil pump to the direction as shown in the figure and check that reading of pressure gauge is 0 MPa.
7. Tighten needle valves A, C, and E of PPMU.

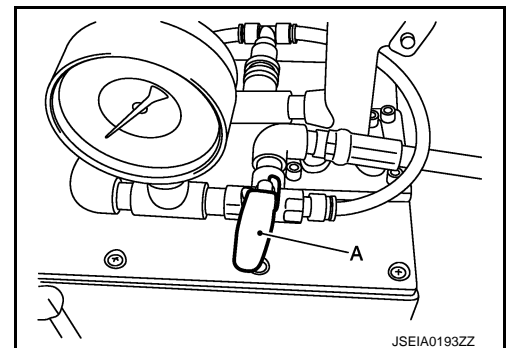

8. Disconnect upper side pipe or lower side pipe of each shock absorber.
 - For front shock absorber

CHECK SHOCK ABSORBER FOR MALFUNCTION

[HBMC]

< BASIC INSPECTION >

- Disconnect upper side pipe (B) of front shock absorber.

A : Lower side pipe

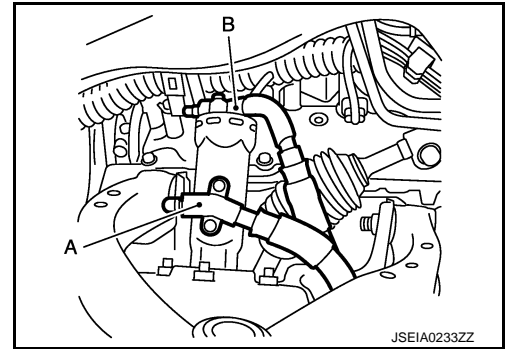

- For rear shock absorber
- Disconnect lower side pipe (B) of rear shock absorber.

A : Upper side pipe

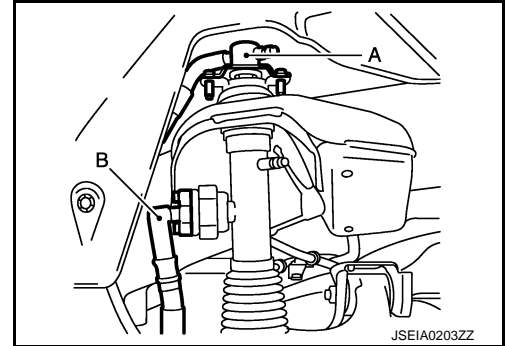

9. Install a leak check plug (SST: KV40108400) (A) to the removed pipe and tighten the leak check plug to the specified torque.

CAUTION:

- O-ring must be free of scratches and damage.
- Piping must be kept free of the intrusion of dust and dirt.

Tightening torque : 5.0 N·m (0.51 kg·m, 44 in·lb)

10. Loosen lock nuts of needle valves B and D of PPMU and then tighten needle valves B and D.
11. Loosening position of needle valve of PPMU varies according to shock absorber that is checked. Loosen needle valve of PPMU by approximately 2 rotations, as per the following table.

CAUTION:

Never loosen the needle valve more than required.

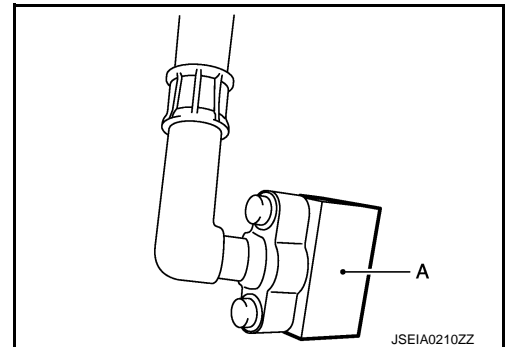

| Shock absorber | Loosening position of needle valve |
|----------------|------------------------------------|
| Front LH | C |
| Rear LH | C |
| Front RH | A |
| Rear RH | A |

12. Set knob (A) of suspension oil pump to the direction as shown in the figure.
13. Apply pressure of up to 2.4 MPa.
14. Go to step 15 when oil comes out from lower portion of shock absorber which pipe is removed from. Go to step 16 when oil does not come out.
15. Replace shock absorber, since shock absorber has internal leakage. Refer to [FSU-10. "Removal and Installation"](#) (front), [RSU-8. "Removal and Installation"](#) (rear).

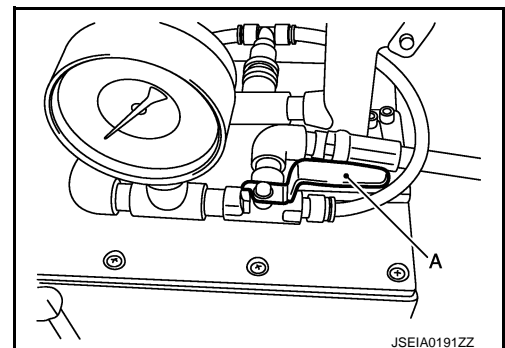

CHECK SHOCK ABSORBER FOR MALFUNCTION

[HBMC]

< BASIC INSPECTION >

16. Shock absorber that is checked is normal. Set knob (A) of suspension oil pump to the direction as shown in the figure and check that reading of pressure gauge is 0 MPa.
17. Tighten the loosened needle valve of PPMU.
18. Remove leak check plug from pipe. Install pipe to lower portion of shock absorber and tighten pipe to the specified torque.

CAUTION:

- O-ring must be free of scratches and damage.
- Piping must be kept free of the intrusion of dust and dirt.

Tightening torque : 5.0 N·m (0.51 kg·m, 44 in·lb)

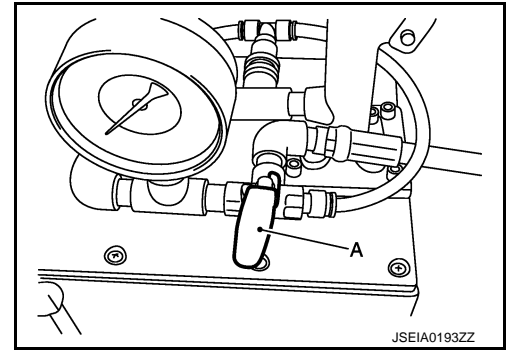

19. Check other shock absorbers in accordance with procedures of steps 8 to 18.
20. Tighten needle valves A, C, and E of PPMU to the specified torque, after completion of check.

Tightening torque : 8.3 N·m (0.85 kg·m, 73 in·lb)

21. Loosen needle valves B and D of PPMU by approximately 2 rotations and then tighten lock nuts to the specified torque.

CAUTION:

Never loosen the needle valve more than required.

Tightening torque : 20 N·m (2.0 kg·m, 15 ft·lb)

CHECK ORIFICE FOR CLOGGING

[HBMC]

< BASIC INSPECTION >

CHECK ORIFICE FOR CLOGGING

Work Procedure

INFOID:00000006256015

CAUTION:

- Clean surrounding areas of oil injection jack using steam before starting operation, since there may be mud on it.
- Clean oil pressure gauge (special service tool: KV40108000) jack with steam before use.

1. Remove protector of PPMU.
2. Remove cap of oil injection jack.
3. Install an oil pressure gauge (SST: KV40108000) (A) to oil injection jack.

CAUTION:

- Jack must be securely inserted until a click sound can be heard.
- Pressure reducing valve (B) of the oil pressure gauge must be closed.

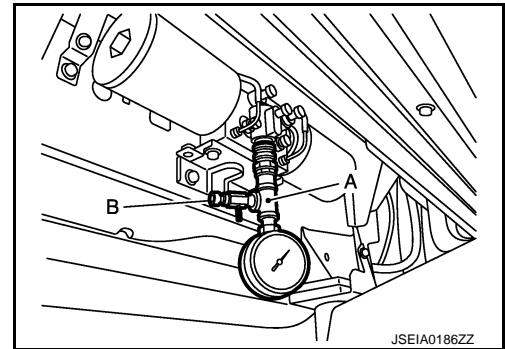

4. Loosen needle valves A, C, and E of PPMU by approximately 2 rotations.

CAUTION:

Never loosen the needle valve more than required.

5. Lift up the vehicle.

CAUTION:

Check that tires never contact the ground.

6. Tighten needle valves A, C, and E of PPMU.

7. Lift down the vehicle.

CAUTION:

Check that the lift is fully lowered.

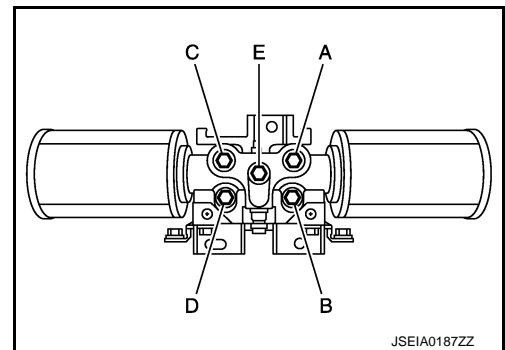

8. Loosen pressure reducing valve (A) of oil pressure gauge and then lower pressure.

CAUTION:

Be careful since oil drains swiftly from oil drain hole (B).

9. Check that reading of oil pressure gauge is 0 MPa. Close pressure reducing valve.

10. Loosen needle valve E of PPMU by approximately 2 rotations.

CAUTION:

Never loosen the needle valve more than required.

11. Write down a value of the oil pressure gauge.

12. Tighten needle valve E of PPMU.

13. Loosen pressure reducing valve of oil pressure gauge and then lower pressure.

CAUTION:

Be careful since oil drains swiftly from oil drain hole.

14. Check that reading of oil pressure gauge is 0 MPa. Close pressure reducing valve.

15. Loosen needle valve A of PPMU by approximately 2 rotations.

CAUTION:

Never loosen the needle valve more than required.

16. Read a value of the oil pressure gauge after 5 minutes.

17. Compare difference of reading with pressure reading in step 11.

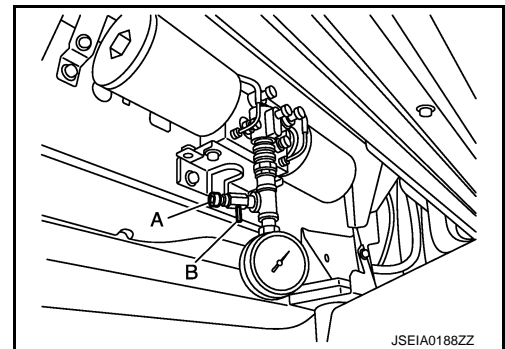

A
B
C
D
E
F
G
H
I
J
K
L
M
N
O
P

SCS

CHECK ORIFICE FOR CLOGGING

< BASIC INSPECTION >

[HBMC]

Pressure difference

0.2 MPa or more : Replace the PPMU. Refer to [SCS-39, "PPMU, MIDDLE TUBE ASSEMBLY, PPMU PIPE : Removal and Installation"](#).

0.2 MPa or less : Normal

18. Tighten needle valve A of PPMU.
19. Loosen pressure reducing valve of oil pressure gauge and then lower pressure.
CAUTION:
Be careful since oil drains swiftly from oil drain hole.
20. Check that reading of oil pressure gauge is 0 MPa. Close pressure reducing valve.
21. Loosen needle valve C of PPMU by approximately 2 rotations.
CAUTION:
Never loosen the needle valve more than required.
22. Read a value of the oil pressure gauge after 5 minutes.
23. Compare difference of reading with pressure reading in step 11.

Pressure difference

0.2 MPa or more : Replace the PPMU. Refer to [SCS-39, "PPMU, MIDDLE TUBE ASSEMBLY, PPMU PIPE : Removal and Installation"](#).

0.2 MPa or less : Normal

24. Tighten needle valve C of PPMU.
25. Loosen pressure reducing valve of oil pressure gauge and then lower pressure.
CAUTION:
Be careful since oil drains swiftly from oil drain hole.
26. Check that reading of oil pressure gauge is 0 MPa.
27. Remove oil pressure gauge.
28. Tighten needle valves A, C, and E of PPMU to the specified torque.

 : **8.3 N·m (0.85 kg·m, 73 in·lb)**

SYMPTOM DIAGNOSIS

DIFFERENCE IN APPEARANCE

Description

INFOID:000000006256016

While the vehicle is stopped, the difference of vehicle height of right side and left side (between wheel center and wheel arch) is 25 mm (0.98 in) or more.

Inspection Procedure

INFOID:000000006256017

1. CHECK APPEARANCE

1. Visually check that the exterior parts (e.g. suspension spring) have no malfunctions.
2. Visually check tube and pipe for crush or oil leakage.

Is the check result normal?

- YES >> GO TO 2.
 NO >> Repair or replace damaged parts.

2. CHECK CLOGGING OF ORIFICE IN PPMU

1. Install an oil pressure gauge (SST: KV40108000) (A) to oil injection jack.

CAUTION:

- Clean surrounding areas of oil injection jack using steam before starting operation, since there may be mud on it.
- Clean oil pressure gauge (special service tool: KV40108000) jack with steam before use.
- Jack must be securely inserted until a click sound can be heard.
- Pressure reducing valve (B) of the oil pressure gauge must be closed.

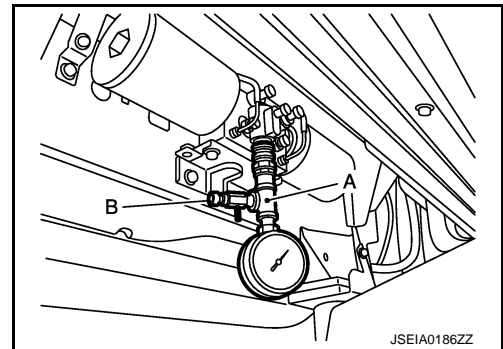

2. Loosen needle valves A and C of PPMU by approximately 2 rotations for check changes in vehicle height.

CAUTION:

Never loosen the needle valve more than required.

3. Tighten needle valve A and C of PPMU to the specified torque after the inspection.

Tightening torque : 8.3 N-m (0.85 kg-m, 73 in-lb)

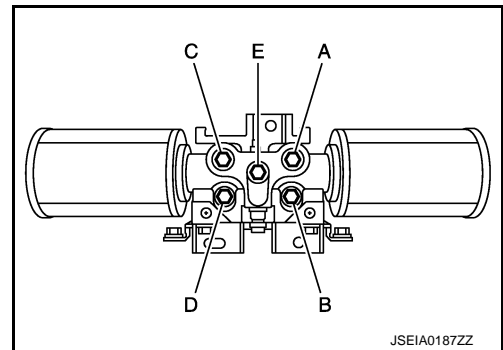

Does the vehicle height change 10 mm (0.39 in) or more?

- YES >> For detailed inspection of clogging of orifice in PPMU, refer to [SCS-27, "Work Procedure"](#).
 NO >> INSPECTION END

A
B
C
D
E
F
G
H
I
J
K
L
M
N
O
P

SCS

LARGE ROLL ANGLE

Description

INFOID:000000006256018

During cornering, inclination of the vehicle to outer side of corner is large.

Inspection Procedure

INFOID:000000006256019

1. CHECK APPEARANCE

1. Visually check that the exterior parts (e.g. suspension spring) have no malfunctions.
2. Visually check tube and pipe for crush or oil leakage.

Is the inspection result normal?

- YES >> GO TO 2.
 NO >> Repair or replace damaged parts.

2. CHECK NEEDLE VALVE OF PPMU

Check that needle valves A and C are tightened to the specified torque.

Tightening torque : 8.3 N·m (0.85 kg·m, 73 in·lb)

Is the inspection result normal?

- YES >> GO TO 3.
 NO >> Tighten to the specified torque.

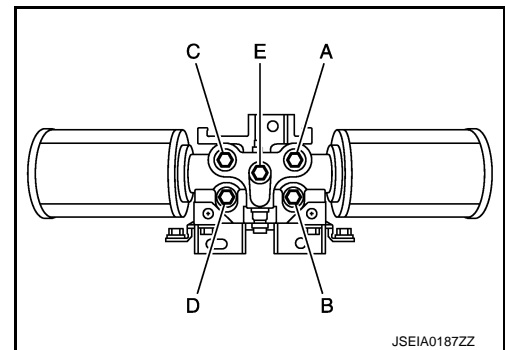

3. SYSTEM PRESSURE CHECK

Check system pressure. Refer to [SCS-15, "Work Procedure"](#).

Is the inspection result normal?

- YES >> GO TO 4.
 NO >> Perform adjustment of system pressure. Refer to [SCS-18, "Work Procedure"](#).

4. CHECK INTERNAL LEAKAGE

Check internal leakage. Refer to [SCS-20, "Work Procedure"](#).

Is the inspection result normal?

- YES >> INSPECTION END
 NO >> GO TO 5.

5. CHECK MALFUNCTIONING PART

Identify malfunctioning part. Refer to [SCS-22, "Work Procedure"](#).

Does the pressure increase?

- YES >> Replace the PPMU. Refer to [SCS-39, "PPMU, MIDDLE TUBE ASSEMBLY, PPMU PIPE : Removal and Installation"](#).
 NO >> GO TO 6.

6. CHECK SHOCK ABSORBER

Identify malfunctioning shock absorber. Refer to [SCS-24, "Work Procedure"](#).

- >> Replace identified shock absorber. Refer to [FSU-10, "Removal and Installation"](#) (front), [RSU-8, "Removal and Installation"](#) (rear).

REMOVAL AND INSTALLATION

HYDRAULIC BODY-MOTION CONTROL SYSTEM

Hydraulic Piping

INFOID:000000006256020

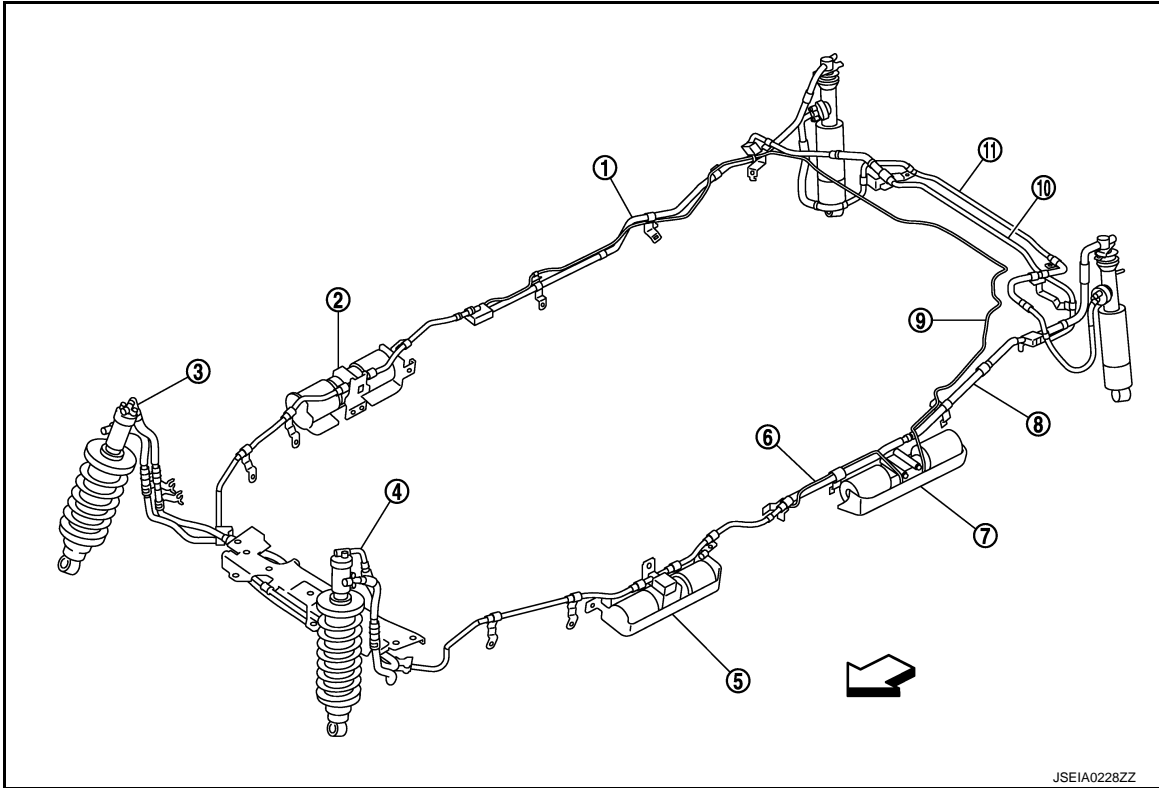

- | | | |
|----------------------------|----------------------------|--------------------------|
| 1. Middle tube assembly RH | 2. Accumulator assembly RH | 3. Front tube assembly A |
| 4. Front tube assembly B | 5. Accumulator assembly LH | 6. PPMU pipe A |
| 7. PPMU assembly | 8. Middle tube assembly LH | 9. PPMU pipe B |
| 10. Rear tube assembly A | 11. Rear tube assembly B | |
- ← Vehicle front

FRONT TUBE ASSEMBLY

A
B
C
D
SCS
F
G
H
I
J
K
L
M
N
O
P

HYDRAULIC BODY-MOTION CONTROL SYSTEM

[HBMC]

< REMOVAL AND INSTALLATION >

FRONT TUBE ASSEMBLY : Exploded View

INFOID:000000006256021

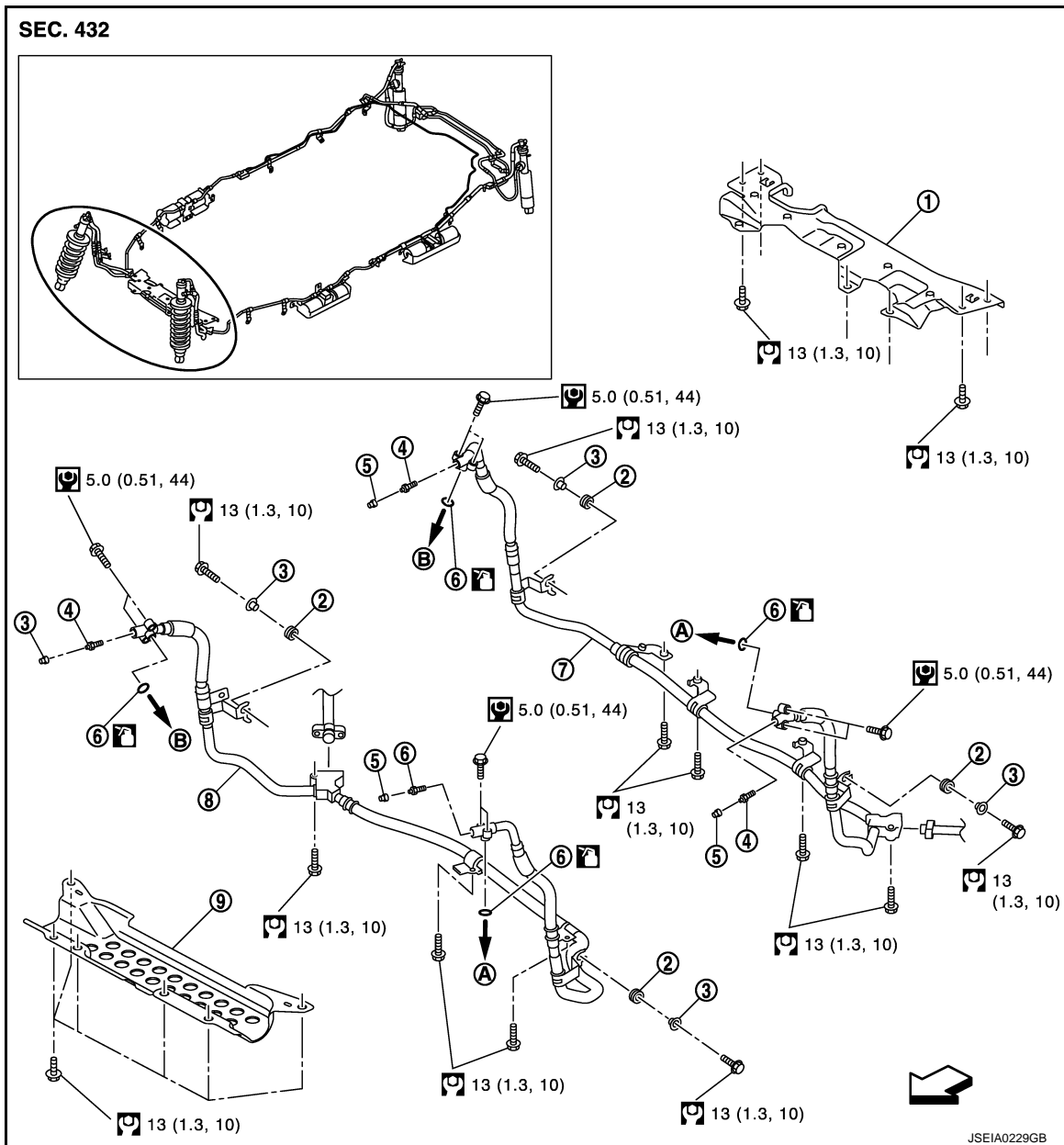

- | | | |
|-------------------------------|---|----------------|
| 1. Protector B | 2. Bushing | 3. Collar |
| 4. Bleeder valve | 5. Cap | 6. O-ring |
| 7. Front tube assembly A | 8. Front tube assembly B | 9. Protector A |
| A. To front shock absorber LH | B. To front shock absorber RH | |
| ← Vehicle front | Apply genuine NISSAN hydraulic suspension fluid | |

Refer to [GI-4, "Components"](#) for symbols not described on the above.

FRONT TUBE ASSEMBLY : Removal and Installation

INFOID:000000006256022

REMOVAL

Front Tube Assembly A (from Front Shock Absorber RH Upper to Front Shock Absorber LH Lower)

1. Reduce system pressure. Refer to [SCS-17, "Work Procedure"](#).

HYDRAULIC BODY-MOTION CONTROL SYSTEM

[HBMC]

< REMOVAL AND INSTALLATION >

2. Disconnect lower side pipe (A) of front shock absorber LH.

B : Upper side pipe

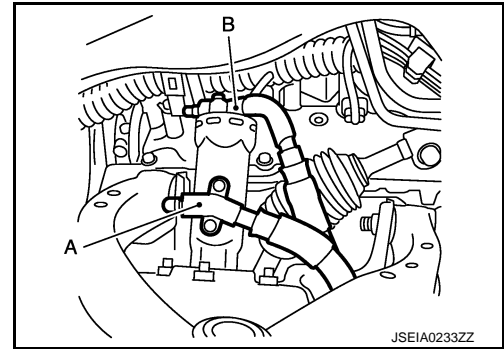

3. Disconnect pipe (A) of accumulator assembly LH from left side 3-way (B).

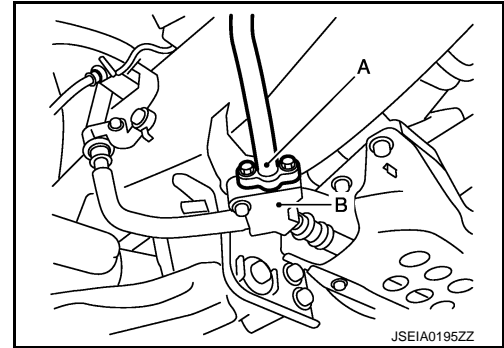

4. Disconnect upper side pipe (A) of front shock absorber RH.

B : Lower side pipe

5. Remove protector A with power tool.
6. Remove mounting bolts of left side 3-way.
7. Remove protector B with power tool.
8. Remove mounting bolts of each bracket.
9. Remove front tube assembly A from the vehicle.
10. Perform inspection after removal. Refer to [SCS-34, "FRONT TUBE ASSEMBLY : Inspection"](#).

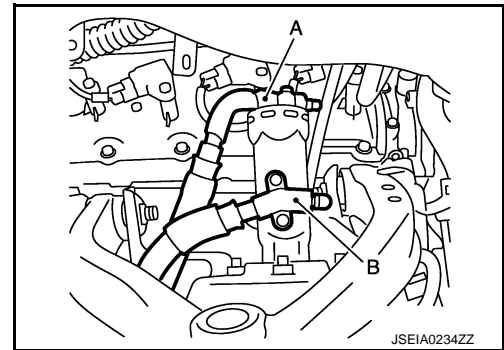

Front Tube Assembly B (from Front Shock Absorber LH Upper to Front Shock Absorber RH Lower)

1. Reduce system pressure. Refer to [SCS-17, "Work Procedure"](#).
2. Disconnect upper side pipe (B) of front shock absorber LH.

A : Lower side pipe

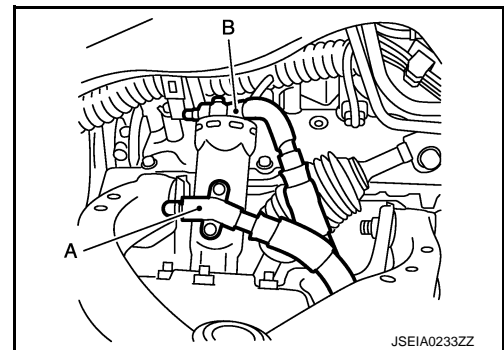

A
B
C
D
SCS
F
G
H
I
J
K
L
M
N
O
P

HYDRAULIC BODY-MOTION CONTROL SYSTEM

[HBMC]

< REMOVAL AND INSTALLATION >

3. Disconnect pipe (A) of accumulator assembly RH from right side 3-way (B).

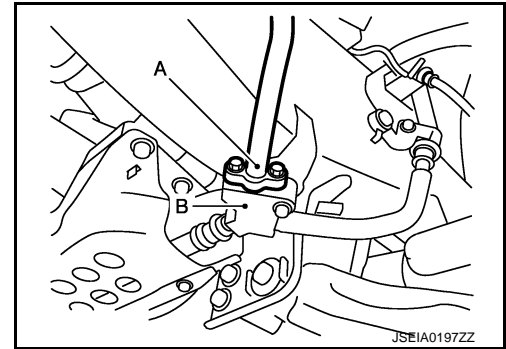

4. Disconnect lower side pipe (B) of front shock absorber RH.

A : Upper side pipe

5. Remove protector A with power tool.
6. Remove mounting bolts of right side 3-way.
7. Remove protector B with power tool.
8. Remove mounting bolts of each bracket.
9. Remove front tube assembly B from the vehicle.
10. Perform inspection after removal. Refer to [SCS-34, "FRONT TUBE ASSEMBLY : Inspection"](#).

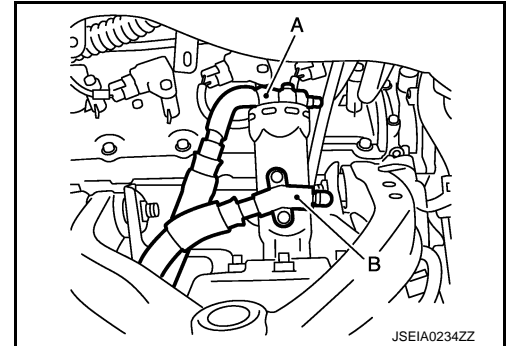

INSTALLATION

Note the following, and install in the reverse order of removal.

- Apply genuine NISSAN hydraulic suspension fluid to O-ring.
- Check connection portion of each piping for dirt or dust.
- Completely insert guide (A) to guide hole on frame when installing left side 3-way.
- For tightening torque for pipe of accumulator assembly LH, refer to [SCS-35, "ACCUMULATOR : Exploded View"](#).
- For tightening torque for pipe of accumulator assembly RH, refer to [SCS-35, "ACCUMULATOR : Exploded View"](#).

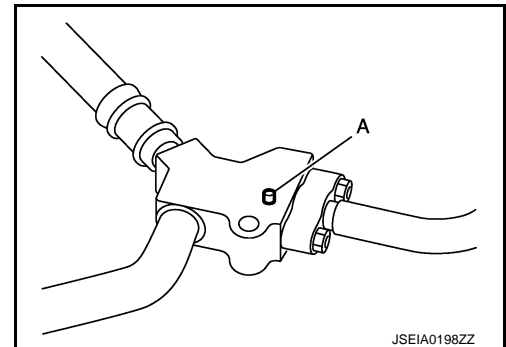

FRONT TUBE ASSEMBLY : Inspection

INFOID:000000006256023

INSPECTION AFTER REMOVAL

- O-ring must be free of scratches and damage.
- Pipe and tube must be free of scratches and damage.

INSPECTION AFTER INSTALLATION

Check oil leakage, twists, deformation, contact with other parts, and loose connections.

ADJUSTMENT AFTER INSTALLATION

Perform air bleeding. Refer to [SCS-18, "Work Procedure"](#).

ACCUMULATOR

HYDRAULIC BODY-MOTION CONTROL SYSTEM

[HBMC]

< REMOVAL AND INSTALLATION >

ACCUMULATOR : Exploded View

INFOID:000000006256024

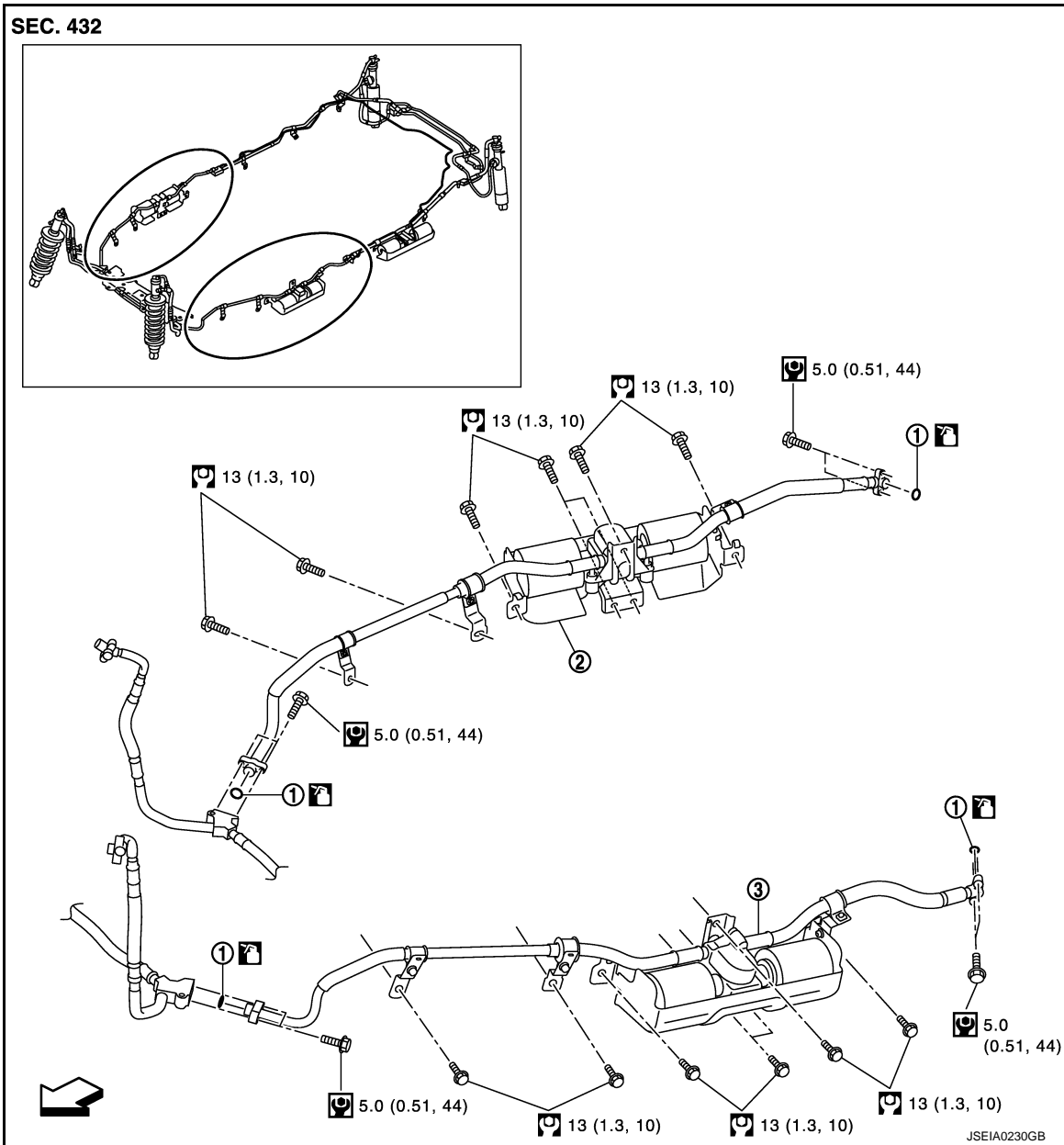

- 1. O-ring
- 2. Accumulator assembly RH
- 3. Accumulator assembly LH
- Vehicle front
- Apply genuine NISSAN hydraulic suspension fluid

Refer to [GI-4. "Components"](#) for symbols not described on the above.

ACCUMULATOR : Removal and Installation

INFOID:000000006256025

REMOVAL

Accumulator Assembly LH

WARNING:

A
B
C
D
SCS
F
G
H
I
J
K
L
M
N
O
P

HYDRAULIC BODY-MOTION CONTROL SYSTEM

< REMOVAL AND INSTALLATION >

[HBMC]

Never remove mounting bolts of protector.

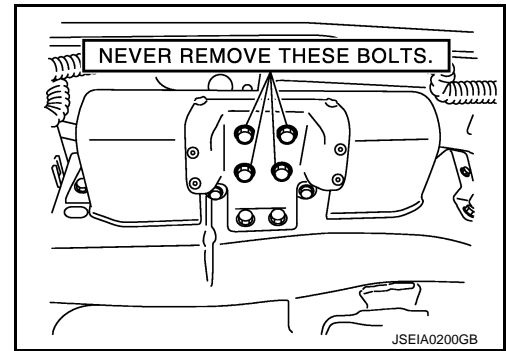

1. Reduce system pressure. Refer to [SCS-17. "Work Procedure"](#).
2. Disconnect pipe (A) of accumulator assembly LH from left side 3-way (B).

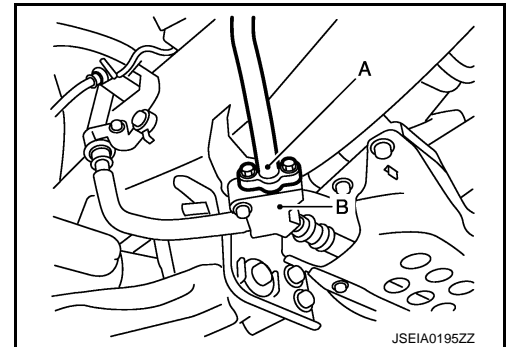

3. Disconnect pipe (A) of accumulator assembly LH from left side middle joint (B).
4. Separate chassis and body. Refer to [DLK-251. "Removal and Installation"](#).
5. Remove mounting bolts of each bracket.

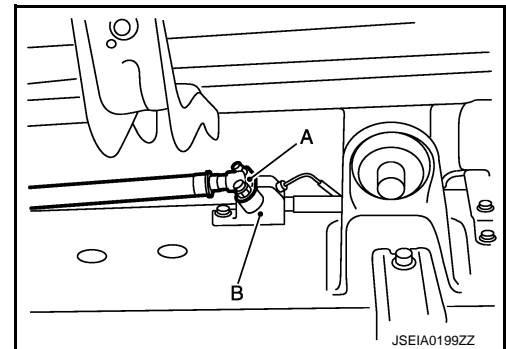

6. Remove mounting bolts of accumulator assembly LH.
WARNING:
Never remove mounting bolts of protector.
7. Remove accumulator assembly LH from the vehicle.
8. Perform inspection after removal. Refer to [SCS-38. "ACCUMULATOR : Inspection"](#).

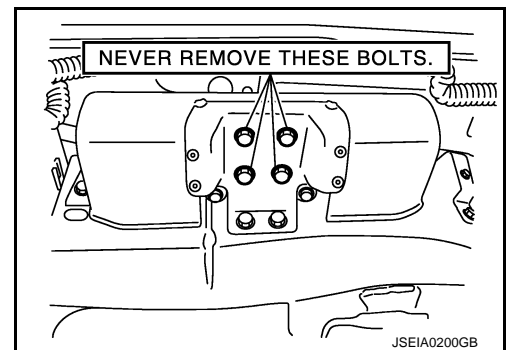

Accumulator Assembly RH

WARNING:

HYDRAULIC BODY-MOTION CONTROL SYSTEM

[HBMC]

< REMOVAL AND INSTALLATION >

Never remove mounting bolts of protector.

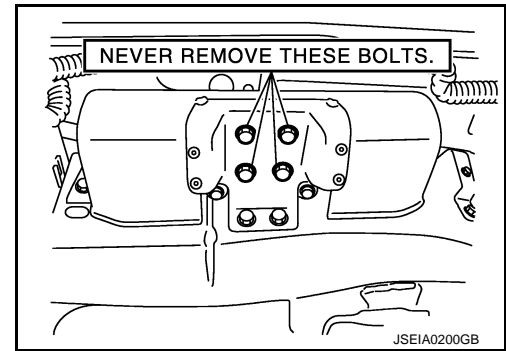

1. Reduce system pressure. Refer to [SCS-17, "Work Procedure"](#).
2. Disconnect pipe (A) of accumulator assembly RH from right side 3-way (B).

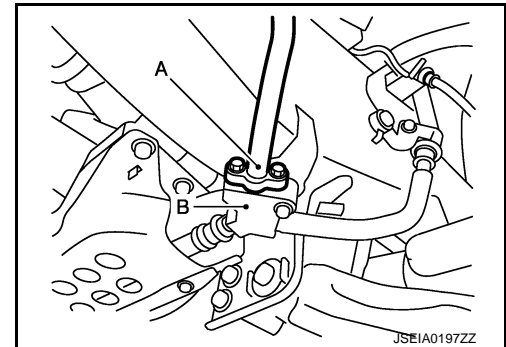

3. Remove pipe (A) of accumulator assembly RH from right side middle joint (B).
4. Separate chassis and body. Refer to [DLK-251, "Removal and Installation"](#).
5. Remove mounting bolts of each bracket.

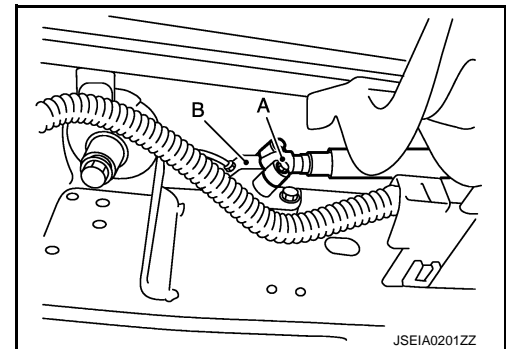

6. Remove mounting bolts of accumulator assembly RH.

WARNING:

Never remove mounting bolts of protector.

7. Remove accumulator assembly RH from the vehicle.
8. Perform inspection after removal. Refer to [SCS-38, "ACCUMULATOR : Inspection"](#).

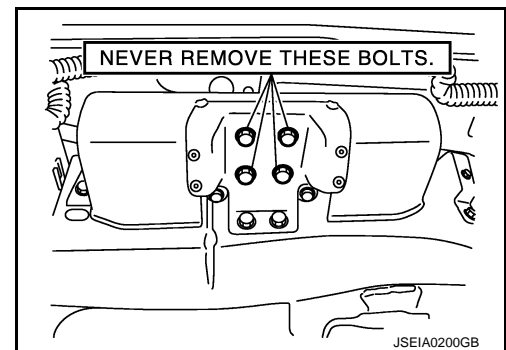

INSTALLATION

Note the following, and install in the reverse order of removal.

- Apply genuine NISSAN hydraulic suspension fluid to O-ring.
- Check connection portion of each piping for dirt or dust.

A
B
C
D
SCS
F
G
H
I
J
K
L
M
N
O
P

HYDRAULIC BODY-MOTION CONTROL SYSTEM

[HBMC]

< REMOVAL AND INSTALLATION >

- Completely engage hooks on frame when installing accumulator assembly.

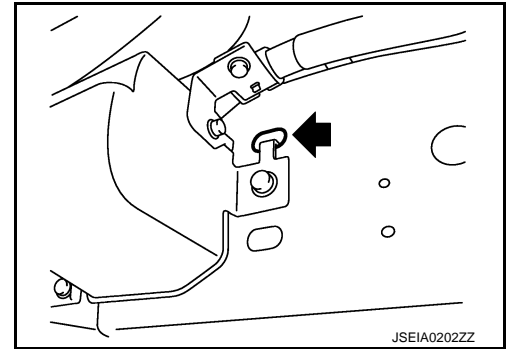

INFOID:000000006256026

ACCUMULATOR : Inspection

INSPECTION AFTER REMOVAL

- O-ring must be free of scratches and damage.
- Pipe and tube must be free of scratches and damage.

INSPECTION AFTER INSTALLATION

Check oil leakage, twists, deformation, contact with other parts, and loose connections.

ADJUSTMENT AFTER INSTALLATION

Perform air bleeding. Refer to [SCS-18. "Work Procedure"](#).

ACCUMULATOR : Disposal

INFOID:000000006256027

CAUTION:

- Always wear safety goggles.
- Always wear safety gloves.
- Be careful since pressure is higher when temperature is high.
- Be careful since metal shavings or oil may be blown away by compressed gas.
- Discard drained oil in accordance with local laws and regulations.

WORK PROCEDURE

1. Remove both tanks using an oil filter wrench.
2. Secure tank using a vise.
3. Drill a hole as shown in the figure (●) using an electric drill. Drain gas and oil.

NOTE:

- Gas is colorless, odorless, and harmless.
- Use an electric drill with a drill bit of approximately 4 mm (0.16 in).
- Drilling a hole is easier when electric drill speed is slow.

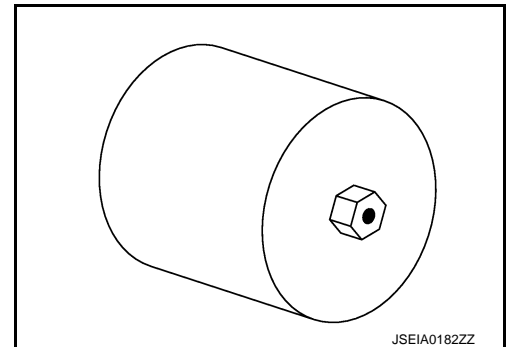

PPMU, MIDDLE TUBE ASSEMBLY, PPMU PIPE

HYDRAULIC BODY-MOTION CONTROL SYSTEM

[HBMC]

< REMOVAL AND INSTALLATION >

PPMU, MIDDLE TUBE ASSEMBLY, PPMU PIPE : Exploded View

INFOID:000000006256028

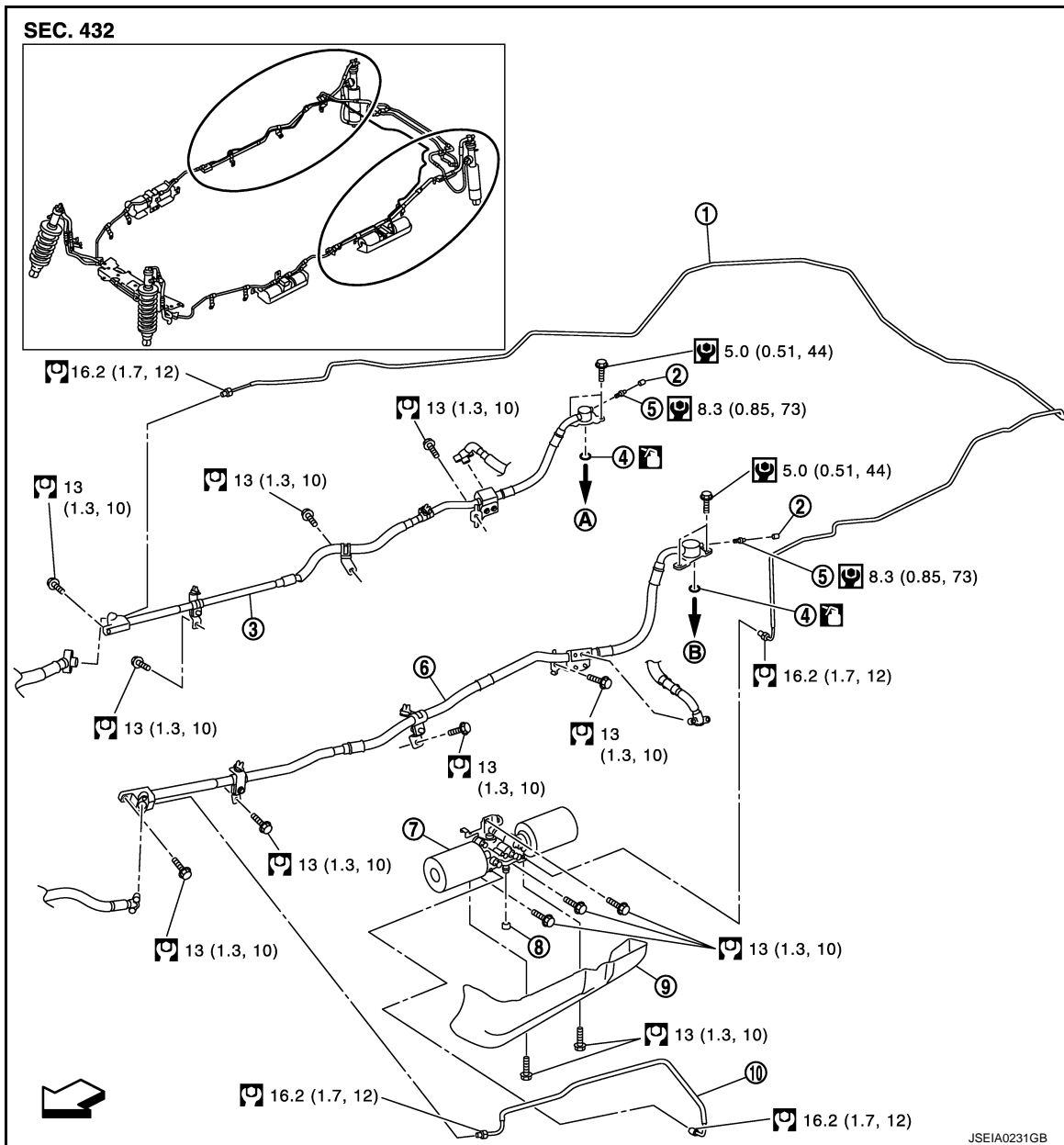

- | | | |
|------------------------------|---|----------------------------|
| 1. PPMU pipe B | 2. Cap | 3. Middle tube assembly RH |
| 4. O-ring | 5. Bleeder valve | 6. Middle tube assembly LH |
| 7. PPMU | 8. Cap | 9. Protector |
| 10. PPMU pipe A | | |
| A. To rear shock absorber RH | B. To rear shock absorber LH | |
| Vehicle front | Apply genuine NISSAN hydraulic suspension fluid | |

Refer to [GI-4, "Components"](#) for symbols not described on the above.

PPMU, MIDDLE TUBE ASSEMBLY, PPMU PIPE : Removal and Installation

INFOID:000000006256029

REMOVAL

PPMU

HYDRAULIC BODY-MOTION CONTROL SYSTEM

[HBMC]

< REMOVAL AND INSTALLATION >

1. Reduce system pressure. Refer to [SCS-17, "Work Procedure"](#).
2. Remove protector.
3. Disconnect PPMU pipe A and PPMU pipe B from PPMU.
4. Remove mounting bolts of PPMU.
5. Remove PPMU from the vehicle.
6. Perform inspection after removal. Refer to [SCS-43, "PPMU, MIDDLE TUBE ASSEMBLY, PPMU PIPE : Inspection"](#).

Middle Tube Assembly LH (from Rear Shock Absorber LH Upper to Left Side Middle Joint)

1. Reduce system pressure. Refer to [SCS-17, "Work Procedure"](#).
2. Remove PPMU.
3. Disconnect upper side pipe (A) of rear shock absorber LH.

B : Lower side pipe

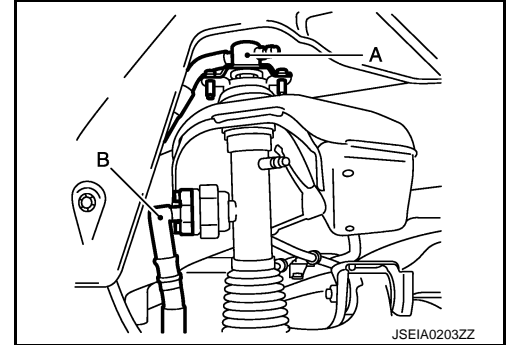

4. Disconnect pipe (A) of rear tube assembly B from left side rear joint (B).

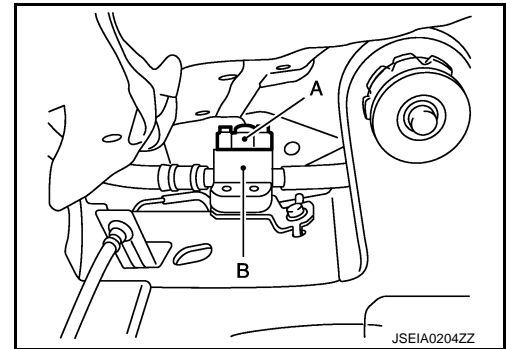

5. Disconnect pipe (A) of accumulator assembly LH from left side middle joint (B).

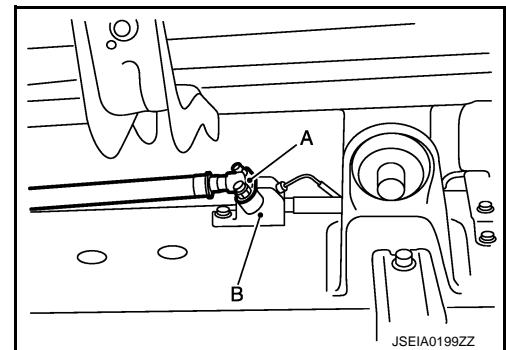

6. Disconnect PPMU pipe A (A) from left side middle joint (B).
7. Separate chassis and body. Refer to [DLK-251, "Removal and Installation"](#).
8. Remove mounting bolts of each bracket.
9. Remove middle tube assembly LH from the vehicle.
10. Perform inspection after removal. Refer to [SCS-43, "PPMU, MIDDLE TUBE ASSEMBLY, PPMU PIPE : Inspection"](#).

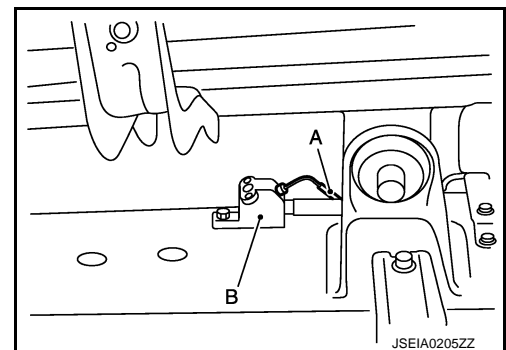

HYDRAULIC BODY-MOTION CONTROL SYSTEM

[HBMC]

< REMOVAL AND INSTALLATION >

Middle Tube Assembly RH (from Rear Shock Absorber RH Upper to Right Side Middle Joint)

1. Reduce system pressure. Refer to [SCS-17, "Work Procedure"](#).
2. Disconnect upper side pipe (A) of rear shock absorber RH.

B : Lower side pipe

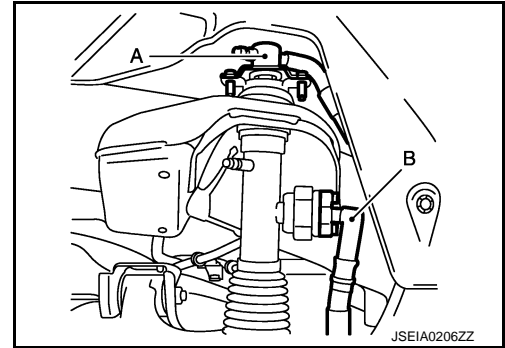

3. Disconnect pipe (A) of rear tube assembly A from right side rear joint (B).

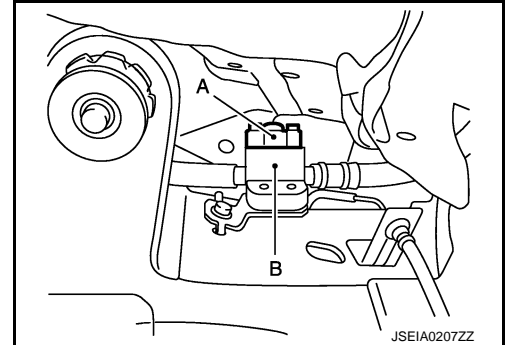

4. Remove pipe (A) of accumulator assembly RH from right side middle joint (B).

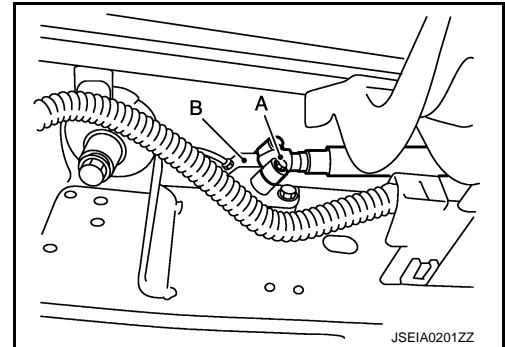

5. Disconnect PPMU pipe B (A) from right side middle joint (B).
6. Separate chassis and body. Refer to [DLK-251, "Removal and Installation"](#).
7. Remove mounting bolts of each bracket.
8. Remove middle tube assembly RH from the vehicle.
9. Perform inspection after removal. Refer to [SCS-43, "PPMU, MIDDLE TUBE ASSEMBLY, PPMU PIPE : Inspection"](#).

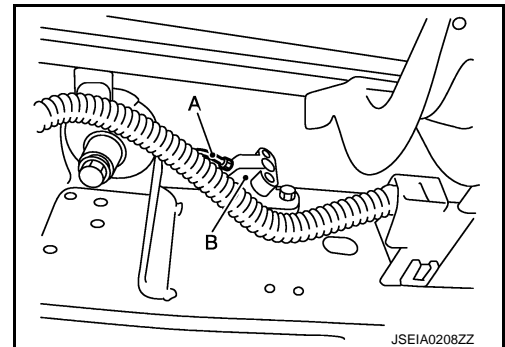

PPMU pipe A and PPMU pipe B

1. Reduce system pressure. Refer to [SCS-17, "Work Procedure"](#).
2. Remove PPMU pipe A from left side middle joint.
3. Remove PPMU pipe B from right side middle joint.
4. Separate chassis and body. Refer to [DLK-251, "Removal and Installation"](#).
5. Remove PPMU pipe B from the vehicle.
6. Perform inspection after removal. Refer to [SCS-43, "PPMU, MIDDLE TUBE ASSEMBLY, PPMU PIPE : Inspection"](#).

HYDRAULIC BODY-MOTION CONTROL SYSTEM

[HBMC]

< REMOVAL AND INSTALLATION >

INSTALLATION

PPMU

Note the following, and install in the reverse order of removal.

- Check connection portion of each piping for dirt or dust.
- Completely engage hooks of bracket on frame when installing PPMU.

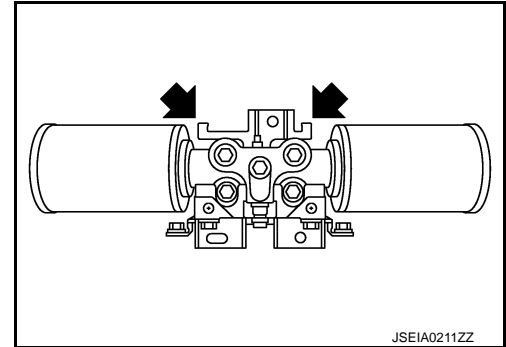

Middle Tube Assembly LH (from Rear Shock Absorber LH Upper to Left Side Middle Joint)

Note the following, and install in the reverse order of removal.

- Apply genuine NISSAN hydraulic suspension fluid to O-ring.
- Check connection portion of each piping for dirt or dust.
- For tightening torque for pipe of rear tube assembly B, refer to [SCS-44. "REAR TUBE ASSEMBLY : Exploded View"](#).
- For tightening torque for pipe of accumulator assembly LH, refer to [SCS-35. "ACCUMULATOR : Exploded View"](#).
- Completely insert guide (A) to guide hole on frame when installing left side middle joint.

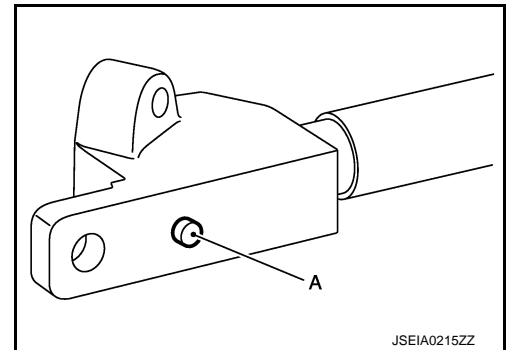

Middle Tube Assembly RH (from Rear Shock Absorber RH Upper to Right Side Middle Joint)

- O-ring must be free of scratches and damage.
- Apply genuine NISSAN hydraulic suspension fluid to O-ring.
- Check connection portion of each piping for dirt or dust.
- For tightening torque for pipe of rear tube assembly A refer to [SCS-44. "REAR TUBE ASSEMBLY : Exploded View"](#).
- For tightening torque for pipe of accumulator assembly RH, refer to [SCS-35. "ACCUMULATOR : Exploded View"](#).
- Completely insert guide (A) to guide hole on frame when installing right side middle joint.

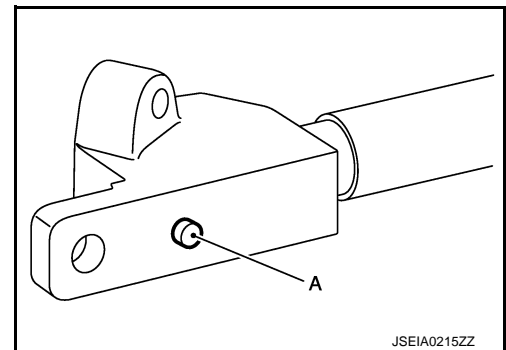

PPMU pipe A and PPMU pipe B

Install in the reverse order of removal.

HYDRAULIC BODY-MOTION CONTROL SYSTEM

[HBMC]

< REMOVAL AND INSTALLATION >

PPMU, MIDDLE TUBE ASSEMBLY, PPMU PIPE : Inspection

INFOID:000000006256030

INSPECTION AFTER REMOVAL

- O-ring must be free of scratches and damage.
- Pipe and tube must be free of scratches and damage.

INSPECTION AFTER INSTALLATION

Check oil leakage, twists, deformation, contact with other parts, and loose connections.

ADJUSTMENT AFTER INSTALLATION

Perform air bleeding. Refer to [SCS-18, "Work Procedure"](#).

PPMU, MIDDLE TUBE ASSEMBLY, PPMU PIPE : Disposal

INFOID:000000006256031

CAUTION:

- Always wear safety goggles.
- Always wear safety gloves.
- Be careful since pressure is higher when temperature is high.
- Be careful since metal shavings or oil may be blown away by compressed gas.
- Discard drained oil in accordance with local laws and regulations.

WORK PROCEDURE

1. Remove both tanks using an oil filter wrench.
2. Secure tank using a vise.
3. Drill a hole as shown in the figure (●) using an electric drill. Drain gas and oil.

NOTE:

- Gas is colorless, odorless, and harmless.
- Use an electric drill with a drill bit of approximately 4 mm (0.16 in).
- Drilling a hole is easier when electric drill speed is slow.

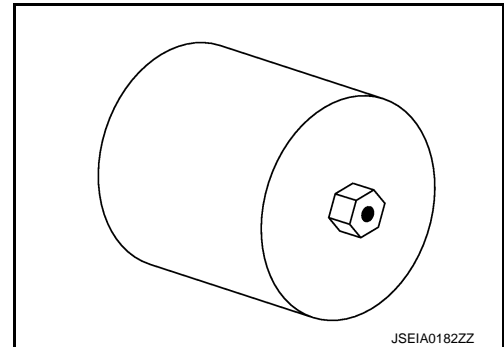

REAR TUBE ASSEMBLY

A
B
C
D
E
F
G
H
I
J
K
L
M
N
O
P

SCS

HYDRAULIC BODY-MOTION CONTROL SYSTEM

[HBMC]

< REMOVAL AND INSTALLATION >

REAR TUBE ASSEMBLY : Exploded View

INFOID:000000006256032

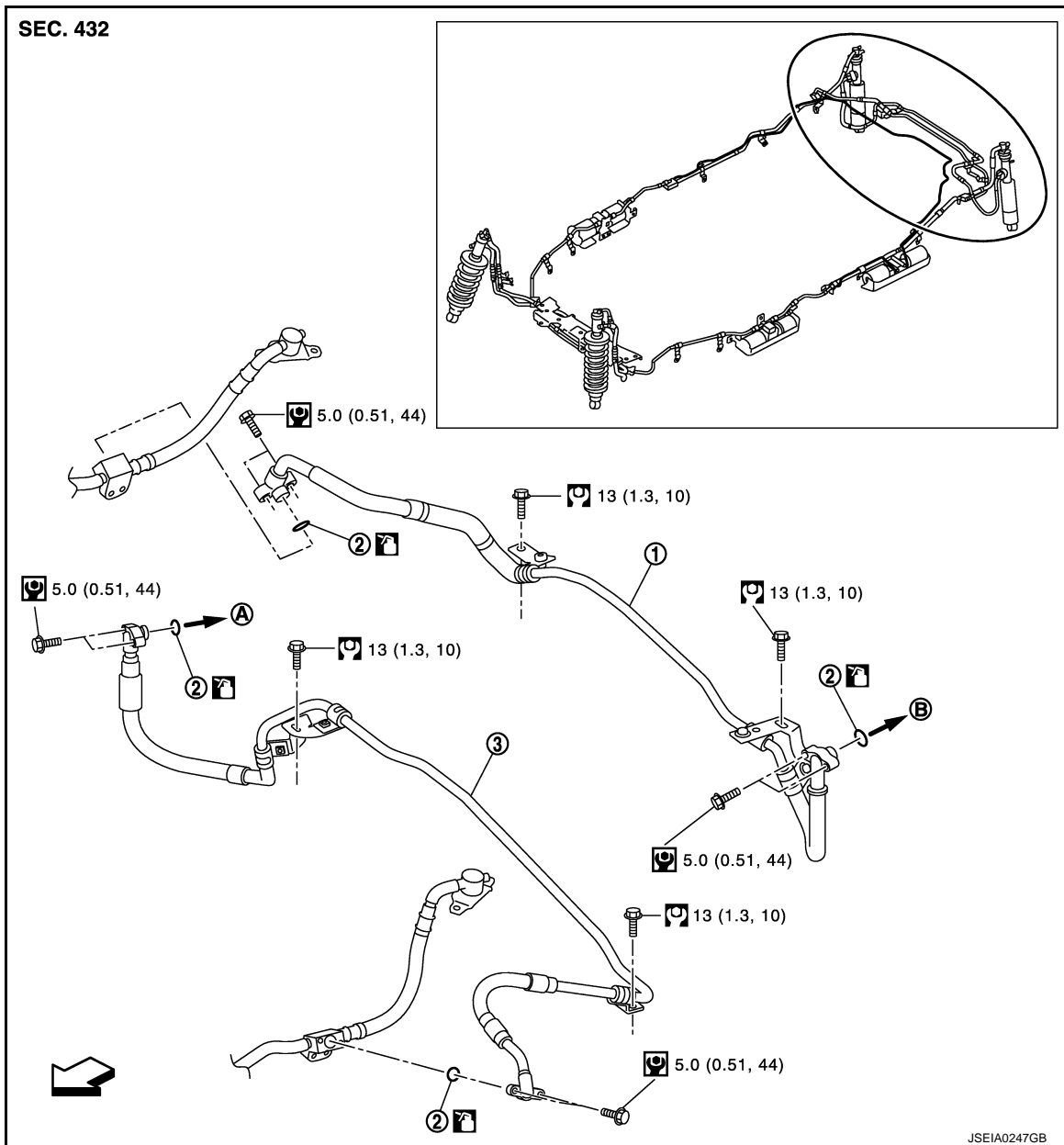

1. Rear tube assembly A

2. O-ring

3. Rear tube assembly B

← Vehicle front

 Apply genuine NISSAN hydraulic suspension fluid

Refer to [GI-4. "Components"](#) for symbols not described on the above.

REAR TUBE ASSEMBLY : Removal and Installation

INFOID:000000006256033

REMOVAL

Rear Tube Assembly A (from Rear Shock Absorber LH Lower to Right Side Rear Joint)

1. Reduce system pressure. Refer to [SCS-17. "Work Procedure"](#).
2. Remove rear muffler. Refer to [EX-5. "Removal and Installation"](#).

HYDRAULIC BODY-MOTION CONTROL SYSTEM

[HBMC]

< REMOVAL AND INSTALLATION >

3. Remove lower side pipe (A) of rear shock absorber LH.

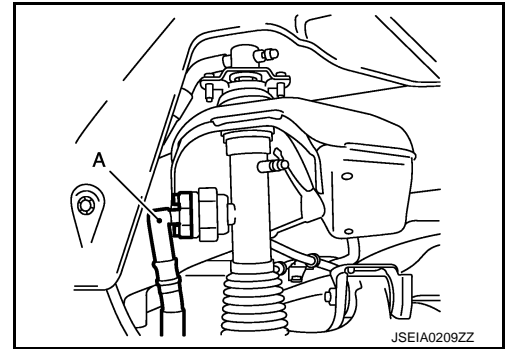

4. Remove pipe (A) from left side rear joint (B).

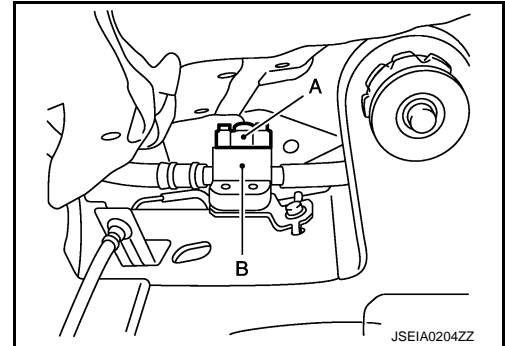

5. Remove lower side pipe (A) of rear shock absorber RH.

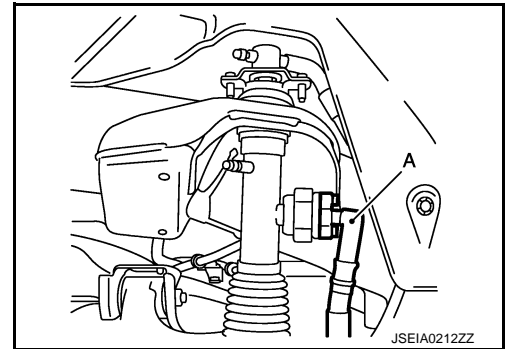

6. Remove pipe (A) from right side rear joint (B).
7. Remove mounting bolts of bracket of rear tube assembly A and B.
8. Remove rear tube assembly A from the vehicle.
9. Perform inspection after removal. Refer to [SCS-46. "REAR TUBE ASSEMBLY : Inspection"](#).

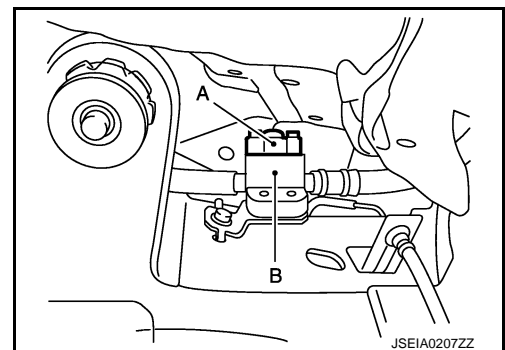

Rear Tube Assembly B (from Rear Shock Absorber RH Lower to Left Side Rear Joint)

1. Reduce system pressure. Refer to [SCS-17. "Work Procedure"](#).
2. Remove rear muffler. Refer to [EX-5. "Removal and Installation"](#).

A
B
C
D
SCS
F
G
H
I
J
K
L
M
N
O
P

HYDRAULIC BODY-MOTION CONTROL SYSTEM

[HBMC]

< REMOVAL AND INSTALLATION >

3. Remove lower side pipe (A) of rear shock absorber RH.

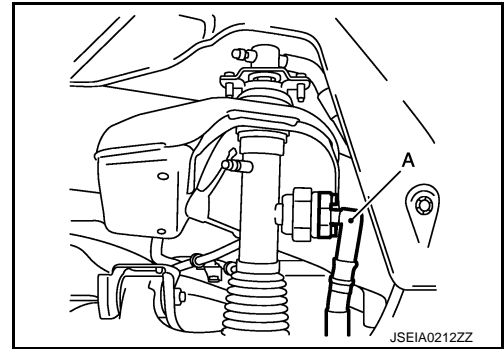

4. Remove pipe (A) from left side rear joint (B).
5. Remove mounting bolts of bracket of rear tube assembly B.
6. Remove mounting bolts of bracket of rear left brake hose, and then free hose.
7. Remove rear tube assembly B from the vehicle.
8. Perform inspection after removal. Refer to [SCS-46. "REAR TUBE ASSEMBLY : Inspection"](#).

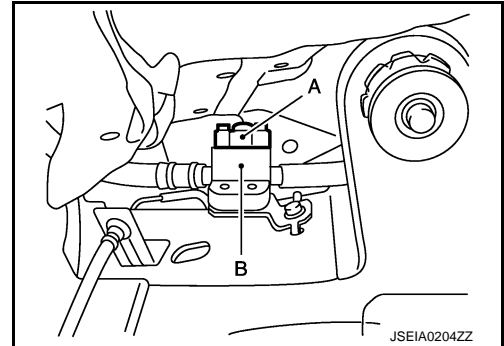

INSTALLATION

Note the following, and install in the reverse order of removal.

- Apply genuine NISSAN hydraulic suspension fluid to O-ring.
- Check connection portion of each piping for dirt or dust.

REAR TUBE ASSEMBLY : Inspection

INFOID:000000006256034

INSPECTION AFTER REMOVAL

- O-ring must be free of scratches and damage.
- Pipe and tube must be free of scratches and damage.

INSPECTION AFTER INSTALLATION

Check oil leakage, twists, deformation, contact with other parts, and loose connections.

ADJUSTMENT AFTER INSTALLATION

Perform air bleeding. Refer to [SCS-18. "Work Procedure"](#).

PRECAUTION

PRECAUTIONS

Precaution for Supplemental Restraint System (SRS) "AIR BAG" and "SEAT BELT PRE-TENSIONER"

INFOID:000000006256135

The Supplemental Restraint System such as "AIR BAG" and "SEAT BELT PRE-TENSIONER", used along with a front seat belt, helps to reduce the risk or severity of injury to the driver and front passenger for certain types of collision. This system includes seat belt switch inputs and dual stage front air bag modules. The SRS system uses the seat belt switches to determine the front air bag deployment, and may only deploy one front air bag, depending on the severity of a collision and whether the front occupants are belted or unbelted. Information necessary to service the system safely is included in the "SRS AIR BAG" and "SEAT BELT" of this Service Manual.

WARNING:

- To avoid rendering the SRS inoperative, which could increase the risk of personal injury or death in the event of a collision that would result in air bag inflation, all maintenance must be performed by an authorized NISSAN/INFINITI dealer.
- Improper maintenance, including incorrect removal and installation of the SRS, can lead to personal injury caused by unintentional activation of the system. For removal of Spiral Cable and Air Bag Module, see the "SRS AIR BAG".
- Do not use electrical test equipment on any circuit related to the SRS unless instructed to in this Service Manual. SRS wiring harnesses can be identified by yellow and/or orange harnesses or harness connectors.

PRECAUTIONS WHEN USING POWER TOOLS (AIR OR ELECTRIC) AND HAMMERS

WARNING:

- When working near the Air Bag Diagnosis Sensor Unit or other Air Bag System sensors with the ignition ON or engine running, DO NOT use air or electric power tools or strike near the sensor(s) with a hammer. Heavy vibration could activate the sensor(s) and deploy the air bag(s), possibly causing serious injury.
- When using air or electric power tools or hammers, always switch the ignition OFF, disconnect the battery, and wait at least 3 minutes before performing any service.

Precaution Necessary for Steering Wheel Rotation after Battery Disconnect

INFOID:000000006256137

NOTE:

- Before removing and installing any control units, first turn the push-button ignition switch to the LOCK position, then disconnect both battery cables.
- After finishing work, confirm that all control unit connectors are connected properly, then re-connect both battery cables.
- Always use CONSULT-III to perform self-diagnosis as a part of each function inspection after finishing work. If a DTC is detected, perform trouble diagnosis according to self-diagnosis results.

For vehicle with steering lock unit, if the battery is disconnected or discharged, the steering wheel will lock and cannot be turned.

If turning the steering wheel is required with the battery disconnected or discharged, follow the operation procedure below before starting the repair operation.

OPERATION PROCEDURE

1. Connect both battery cables.

NOTE:

Supply power using jumper cables if battery is discharged.

2. Turn the push-button ignition switch to ACC position.
(At this time, the steering lock will be released.)
3. Disconnect both battery cables. The steering lock will remain released with both battery cables disconnected and the steering wheel can be turned.
4. Perform the necessary repair operation.

A
B
C
D
SCS
F
G
H
I
J
K
L
M
N
O
P

PRECAUTIONS

< PRECAUTION >

[AIR LEVELIZER CONTROL SYSTEM]

5. When the repair work is completed, re-connect both battery cables. With the brake pedal released, turn the push-button ignition switch from ACC position to ON position, then to LOCK position. (The steering wheel will lock when the push-button ignition switch is turned to LOCK position.)
6. Perform self-diagnosis check of all control units using CONSULT-III.

Precaution for Procedure without Cowl Top Cover

INFOID:000000006256139

When performing the procedure after removing cowl top cover, cover the lower end of windshield with urethane, etc.

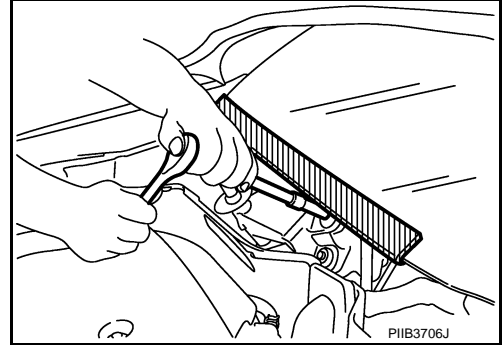

INFOID:000000006256038

Precaution for Air Levelizer Control System

- Never allow water and dust to enter the inside of air compressor.
- Never disassemble the vehicle height sensor.

SYSTEM DESCRIPTION

DESCRIPTION

Description

INFOID:000000006256039

- Corrects sinkage of vehicle rear that occurs in laden or towing conditions.
- Maintains vehicle height at a constant level and improves riding comfort by charging or discharging air in air chamber of rear shock absorber, according to signal from vehicle height sensor installed to rear suspension.

A

B

C

D

F

G

H

I

J

K

L

M

N

O

P

SCS

COMPONENT PARTS

< SYSTEM DESCRIPTION >

[AIR LEVELIZER CONTROL SYSTEM]

COMPONENT PARTS

Component Parts Location

INFOID:000000006256040

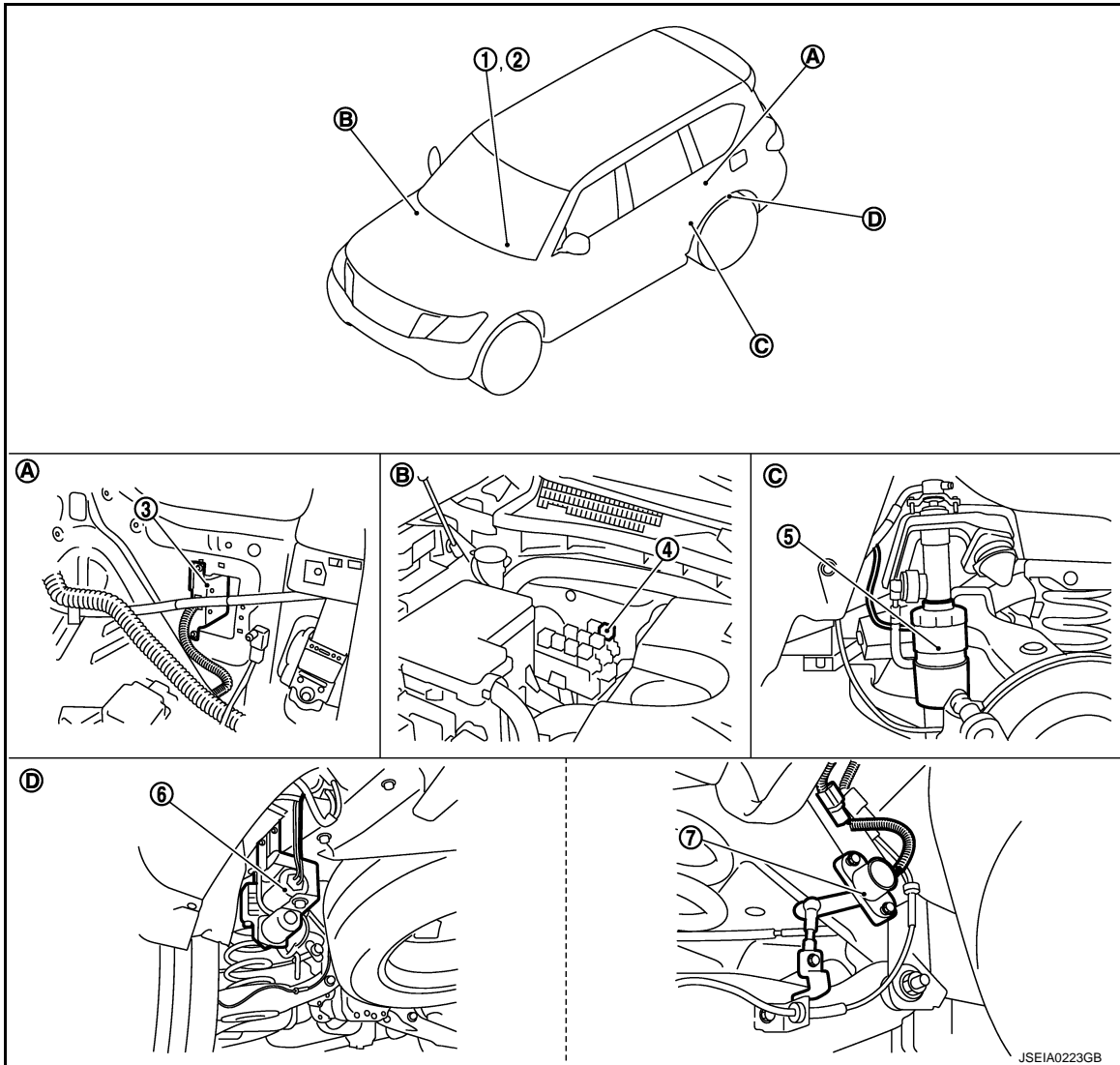

- | | | |
|---|---------------------------|---------------------------------|
| 1. Combination meter Refer to MWI-6, "METER SYSTEM : Component Parts Location" . | 2. CK SUSP indicator lamp | 3. Air levelizer control module |
| 4. Air compressor relay | 5. Air chamber | 6. Air compressor |
| 7. Vehicle height sensor | | |
| A. Inside of luggage side finisher lower (LH) | B. Engine room (RH) | C. Rear shock absorber |
| D. Vehicle rear (LH) | | |

Component Description

INFOID:000000006256041

| Component parts | Reference |
|------------------------------|--|
| Air levelizer control module | SCS-51, "Air Levelizer Control Module" |
| Vehicle height sensor | SCS-51, "Vehicle Height Sensor" |
| Air compressor | SCS-51, "Air Compressor" |
| Exhaust solenoid | |

COMPONENT PARTS

< SYSTEM DESCRIPTION >

[AIR LEVELIZER CONTROL SYSTEM]

| Component parts | Reference |
|------------------------|--|
| Air compressor relay | SCS-51, "Air Compressor Relay" |
| CK SUSP indicator lamp | SCS-51, "CK SUSP Indicator Lamp" |

Air Levelizer Control Module

INFOID:000000006256042

- Operates ON/OFF of air compressor (exhaust solenoid), according to signal from vehicle height sensor.
- Transmits CK SUSP indicator lamp signal to the combination meter via CAN communication, when setting of standard vehicle height is incomplete.
- If malfunction is detected, the system enters fail-safe mode. Refer to [SCS-59, "Fail-safe"](#).

Vehicle Height Sensor

INFOID:000000006256043

Measures vehicle height of vehicle rear and transmits this information to air levelizer control module according to electric signal.

Air Compressor

INFOID:000000006256044

Operates according to signal from air levelizer control module via air compressor relay, and charges air in air chamber of rear shock absorber.

EXHAUST SOLENOID

Operates according to signal from air levelizer control module, and discharges air in air chamber of rear shock absorber.

Air Compressor Relay

INFOID:000000006256045

Turns ON according to signal from air levelizer control module, and operates air compressor.

CK SUSP Indicator Lamp

INFOID:000000006256046

- Turns ON for 2 seconds when ignition switch is turned ON, for the purpose of bulb check.
- Turns ON when setting of standard vehicle height is incomplete.

NOTE:

Does not turn ON when the system is malfunctioning.

A
B
C
D
E
F
G
H
I
J
K
L
M
N
O
P

SCS

STRUCTURE AND OPERATION

[AIR LEVELIZER CONTROL SYSTEM]

< SYSTEM DESCRIPTION >

STRUCTURE AND OPERATION

Rear Shock Absorber

INFOID:00000006256047

- Discharges air in air chamber (2) from air valve (1) when vehicle height of vehicle rear is higher than standard vehicle height, has shock absorber stroke in compressed direction, lowers vehicle height, and returns it to standard vehicle height.
- Also charges air in air chamber from air valve when height of vehicle rear is lower than standard vehicle height, has shock absorber stroke in extending direction, raises vehicle height, and returns it to standard vehicle height.
- Charged air, because of rubber (3) that is hard and located on side surface, does not expand in lateral direction, but expands in vertical direction, and enables shock absorber to extend or retract.

Without Hydraulic Body-Motion Control System

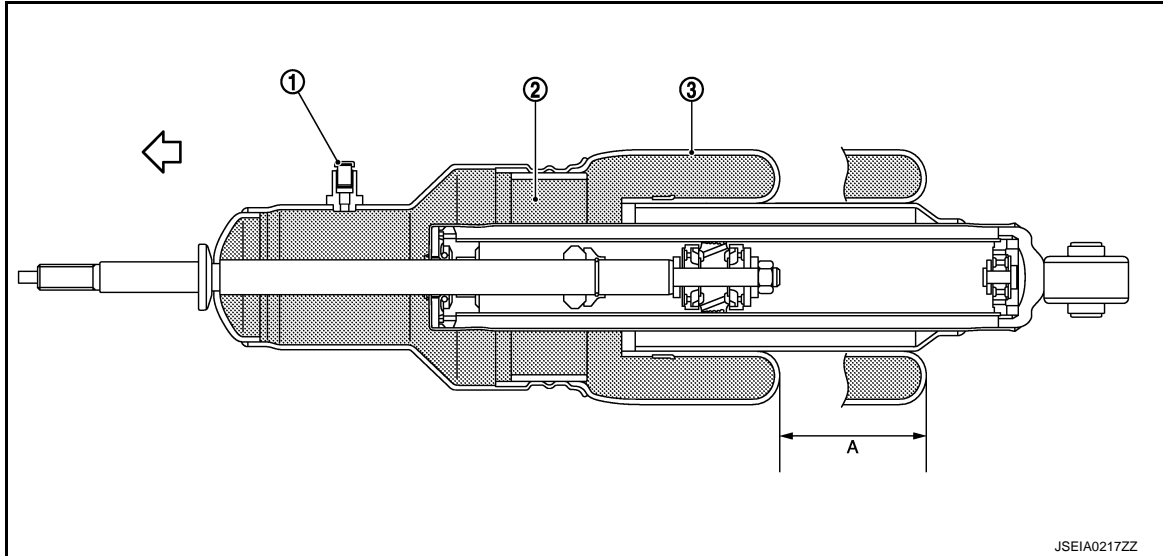

- | | | | | | |
|----|---------------|----|-------------|----|--------|
| 1. | Air valve | 2. | Air chamber | 3. | Rubber |
| A. | Stroke | | | | |
| ← | Vehicle upper | | | | |

With Hydraulic Body-Motion Control System

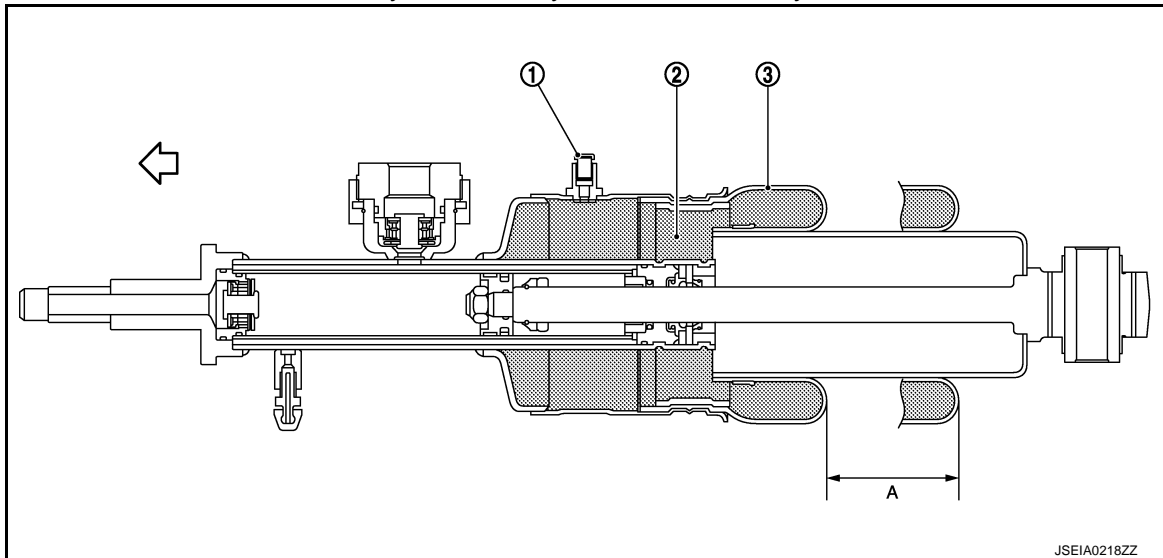

- | | | | | | |
|----|---------------|----|-------------|----|--------|
| 1. | Air valve | 2. | Air chamber | 3. | Rubber |
| A. | Stroke | | | | |
| ← | Vehicle upper | | | | |

STRUCTURE AND OPERATION

[AIR LEVELIZER CONTROL SYSTEM]

< SYSTEM DESCRIPTION >

Vehicle Height Sensor

INFOID:000000006256048

Vehicle height sensor is installed between rear suspension member (1) and rear lower link (2).

Since arm (A) portion and rod (B) portion are ball joint type, distance between rear suspension member and rear lower link shortens when vehicle height of vehicle rear lowers because of laden or towing conditions, and arm portion changes to the status that is higher in its left side as shown in the figure.

This angle change in arm portion is transmitted to the air levelizer control module according to electric signal.

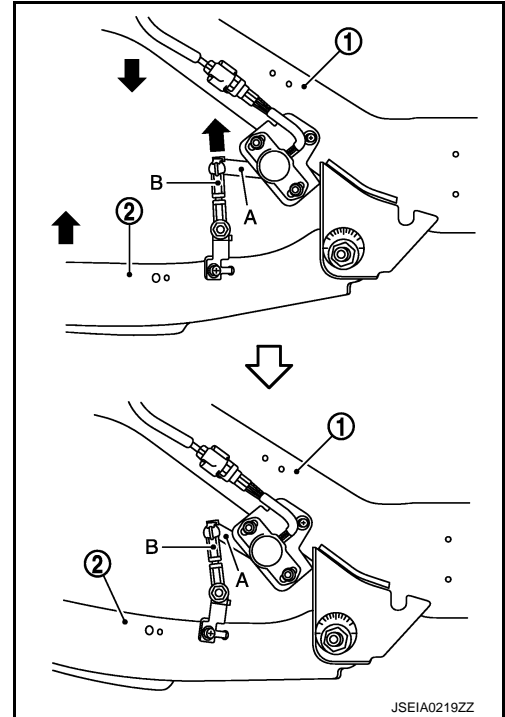

A
B
C
D
SCS
F
G
H
I
J
K
L
M
N
O
P

SYSTEM

System Diagram

INFOID:000000006256049

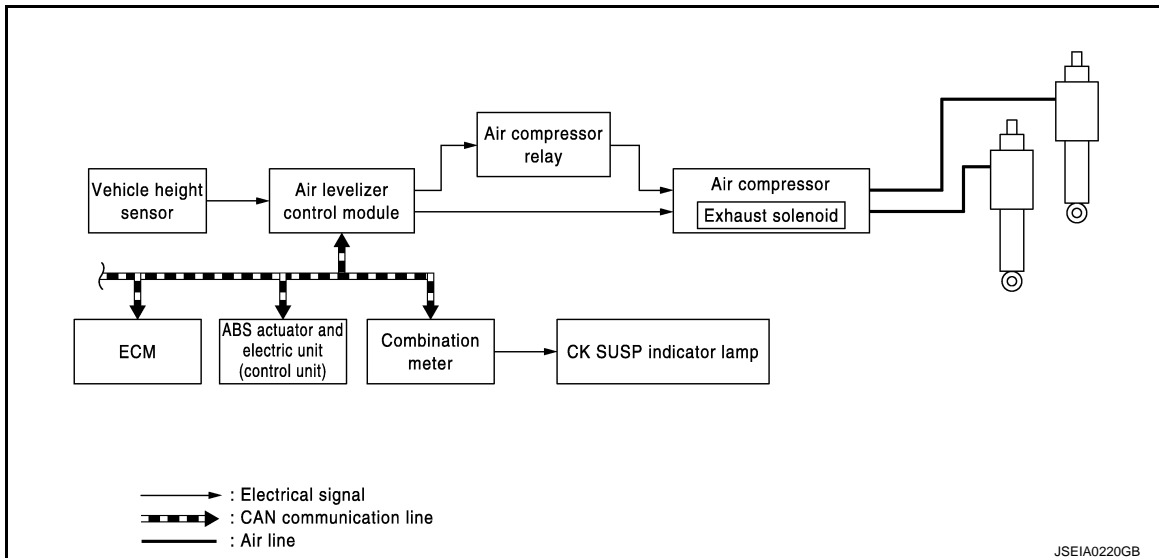

System Description

INFOID:000000006256050

- Based on the signal from the vehicle height sensor, the air levelizer control module operates the air compressor (exhaust solenoid) and controls vehicle height so that it remains at a constant height. This operation occurs if vehicle height of vehicle rear is judged to be 15 mm (0.59 in) or more or 15 mm (0.59 in) or less than standard vehicle height, continuously for 30 seconds, when engine is started.
- If malfunction is detected, the system enters fail-safe mode. Refer to [SCS-59, "Fail-safe"](#).

INPUT/OUTPUT SIGNAL

Air levelizer control module transmits and receives following signals between each control unit via CAN communication line.

| Component parts | Control signal |
|---|---|
| ECM | Transmits the following signal via CAN communication line to air levelizer control module. <ul style="list-style-type: none"> • Engine speed signal |
| Combination meter | Receives the following signal via CAN communication line from air levelizer control module. <ul style="list-style-type: none"> • CK SUSP indicator lamp signal |
| ABS actuator and electric unit (control unit) | Transmits the following signal via CAN communication line to air levelizer control module. <ul style="list-style-type: none"> • Vehicle speed signal |

OPERATING PRINCIPLE

System Time Table

SYSTEM

< SYSTEM DESCRIPTION >

[AIR LEVELIZER CONTROL SYSTEM]

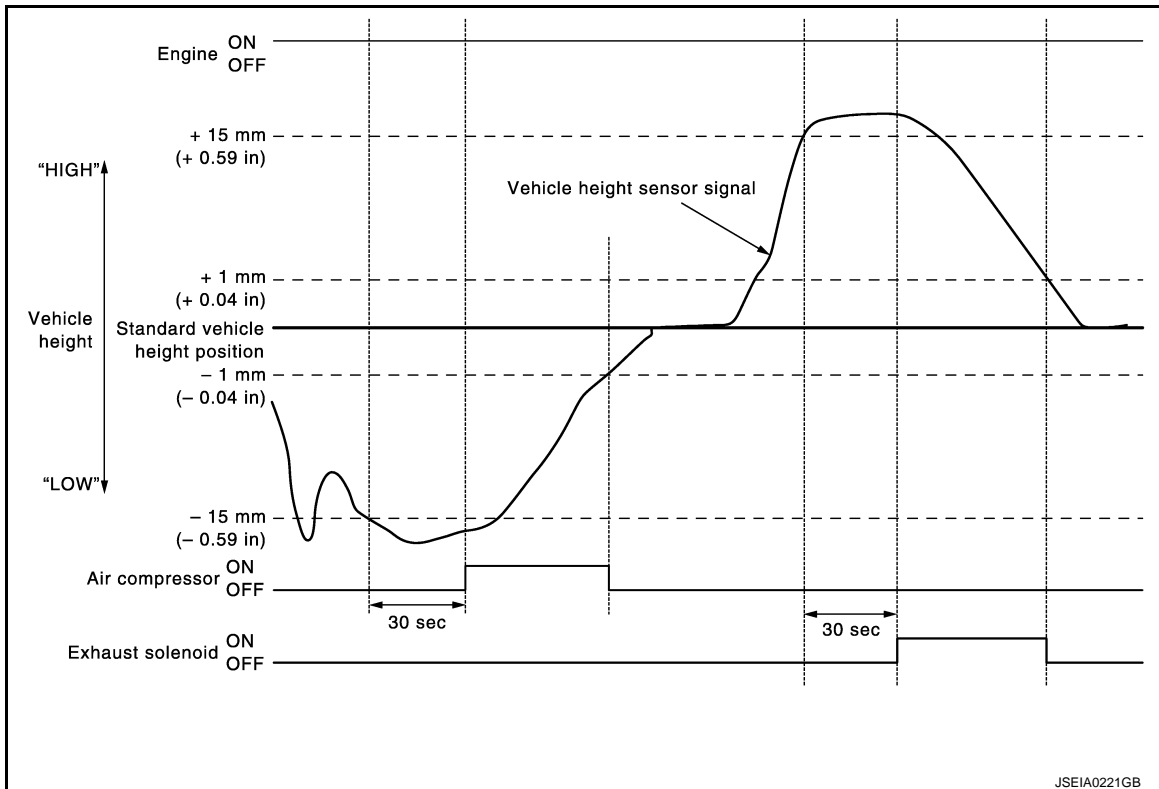

A

B

C

D

SCS

F

G

H

Vehicle height raises [When starting engine, if vehicle height of vehicle rear continues for 30 seconds or more in a status that is 15 mm (0.59 in) or less than standard vehicle height]

1. Vehicle height sensor detects vehicle height status, and transmits this information to air levelizer control module.
2. Air levelizer control module turns air compressor relay ON and operates air compressor.
3. Air compressor charges air in air chamber of shock absorber.
4. Vehicle height raises, and control is complete when status is -1 mm (-0.04 in) of standard vehicle height value.

I

J

Vehicle height lowers [When starting engine, if vehicle height of vehicle rear continues for 30 seconds or more in a status that is 15 mm (0.59 in) or more of standard vehicle height]

1. Vehicle height sensor detects vehicle height status, and transmits this information to air levelizer control module.
2. Air levelizer control module turns exhaust solenoid of air compressor ON.
3. Air compressor discharges air from air chamber of shock absorber.
4. Vehicle height lowers, and control is complete when status is +1 mm (+0.04 in) of standard vehicle height.

K

L

Fail-safe

INFOID:000000006256051

If malfunction is detected, control stops.

The system may enter fail-safe mode under certain conditions (for example, over-laden conditions) when electronic circuit is normal.

In this case, always check that the system returns to normal by starting engine after unloading load.

M

N

O

P

DIAGNOSIS SYSTEM (AIR LEVELIZER CONTROL MODULE)

< SYSTEM DESCRIPTION >

[AIR LEVELIZER CONTROL SYSTEM]

DIAGNOSIS SYSTEM (AIR LEVELIZER CONTROL MODULE)

CONSULT-III Function

INFOID:000000006256052

CONSULT-III APPLICATION ITEMS

| Diagnostic test mode | Function |
|--------------------------------|---|
| Work Support | This mode enables a technician to adjust some devices faster and more accurately. |
| Self Diagnostic Results | Retrieve DTC from ECU and display diagnostic items. |
| Data Monitor | Monitor the input/output signal of the control unit in real time. |
| CAN Diagnosis | This mode displays a network diagnosis result about CAN by a diagram. |
| CAN Diagnostic Support Monitor | It monitors the status of CAN communication. |
| ECU Identification | Display the ECU identification number (part number etc.) of the selected system. |
| Active Test | Send the drive signal from CONSULT-III to the actuator. The operation check can be performed. |

WORK SUPPORT

CAUTION:

Perform the procedure when the vehicle is stopped.

| Item name | Description |
|-----------------------|--|
| STANDARD HEIGHT LEVEL | Forcibly sets vehicle height to the set standard vehicle height. |
| ADJUST HEIGHT INI | Sets standard vehicle height. |
| CLEAR HEIGHT INI | Erases standard vehicle height. |

SELF DIAGNOSTIC RESULTS

Refer to [SCS-59, "DTC Index"](#).

When "CRNT" is displayed on self-diagnosis result,

- The system is presently malfunctioning.

When "PAST" is displayed on self-diagnosis result,

- System malfunction in the past is detected, but the system is presently normal.

Freeze frame data (FFD)

| Item name | Description |
|-------------|--|
| IGN COUNTER | <p>The number of times that ignition switch is turned ON after the DTC is detected is displayed.</p> <ul style="list-style-type: none">• When "0" is displayed: It indicates that the system is presently malfunctioning.• When except "0" is displayed: It indicates that system malfunction in the past is detected, but the system is presently normal. <p>NOTE: Each time when ignition switch is turned OFF to ON, numerical number increases in 1 → 2 → 3...38 → 39. When the operation number of times exceeds 39, the number do not increase and "39" is displayed until self-diagnosis is erased.</p> |

DATA MONITOR

| Monitored item (Unit) | Remarks |
|--------------------------|---|
| IGN VOLT (V) | Displays the power supply voltage of air levelizer control module. |
| VHCL HT INTLZ STA | Displays setting status of standard vehicle height. |
| VHCL HT INIT SLCT | Displays setting status of standard vehicle height. |
| VHCL HEIGHT SEN (V) | Displays the signal voltage of vehicle height sensor. |
| VHCL HT CNVSN VL (mm) | Displays the vehicle height recognized by air levelizer control module. |
| VHCL HGT FIX TIME (hour) | Displays period of time that signal from vehicle height sensor does not change. |

DIAGNOSIS SYSTEM (AIR LEVELIZER CONTROL MODULE)

< SYSTEM DESCRIPTION >

[AIR LEVELIZER CONTROL SYSTEM]

| Monitored item (Unit) | Remarks |
|-----------------------|---|
| VHCL HGT INIT VAL (V) | <ul style="list-style-type: none"> • Displays voltage when standard vehicle height is set. • Value does not change until setting of standard vehicle height is performed again. |
| COMPRESSOR | Displays operation status of air compressor. |
| EXH SOLENOID | Displays operation status of exhaust solenoid. |
| ENG SPEED SIG | Displays operation status of engine. |
| WARNING LAMP | Displays turning ON status of CK SUSP indicator lamp. |

ACTIVE TEST

CAUTION:

- Perform the procedure when the vehicle is stopped.
- Be careful that battery is not discharged when performing the procedure while engine is stopped.

| Item name | Description |
|------------------|---|
| COMPRESSOR | Air compressor can be operated. |
| EXHAUST SOLENOID | Ehaust solenoid of air compressore can be operated. |
| WARNING LAMP | CK SUSP indicator lamp can be turned ON or OFF. |

A
B
C
D
F
G
H
I
J
K
L
M
N
O
P

SCS

AIR LEVELIZER CONTROL MODULE

< ECU DIAGNOSIS INFORMATION >

[AIR LEVELIZER CONTROL SYSTEM]

ECU DIAGNOSIS INFORMATION

AIR LEVELIZER CONTROL MODULE

Reference Value

INFOID:000000006256053

VALUES ON DIAGNOSIS TOOL

| Item name | Condition | Value/Status (Approx.) |
|-------------------|---|------------------------|
| IGN VOLT | Ignition switch ON | 10 – 16 V |
| VHCL HT INTLZ STA | Completion of the standard vehicle height setting | CMPLT |
| | Other than the above | INCMP |
| VHCL HT INIT SLCT | Completion of the standard vehicle height setting | 1 |
| | Other than the above | 0 |
| VHCL HEIGHT SEN | Lift up the vehicle | 2.8 – 3.8 V |
| VHCL HT CNVSN VL | Lift down the vehicle | -15 – 15 mm |
| VHCL HGT FIX TIME | Lift up the vehicle | 0 h |
| VHCL HGT INIT VAL | Completion of the standard vehicle height setting | 2.800 – 3.800 V |
| | Other than the above | 0 V |
| COMPRESSOR | When the air compressor is operating | On |
| | Other than the above | Off |
| EXH SOLENOID | When exhaust solenoid is operating | On |
| | Other than the above | Off |
| ENG SPEED SIG | Engine running | RUN |
| | Other than the above | STOP |
| WARNING LAMP | When CK SUSP indicator lamp is ON | On |
| | Other than the above | Off |

TERMINAL LAYOUT

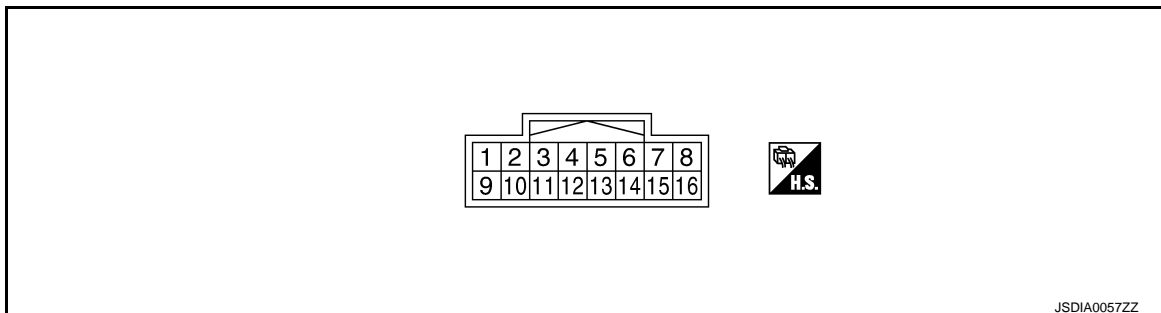

PHYSICAL VALUES

| Terminal (Wire color) | | Description | | Condition | Reference value (Approx.) |
|--------------------------|--------|--------------------------------|------------------|--------------------------------------|--------------------------------|
| + | - | Signal name | Input/ Output | | |
| 2 (B) | Ground | GND | — | Always | Less than 1 Ω |
| 3 (V) | Ground | Air compressor relay | Output | IGN ON | Air compressor: ON 9 – 16 V |
| | | | | Air compressor: OFF Less than 2 V | |
| 4 (L/W) | Ground | Vehicle height sensor (GND) | — | Always | Less than 1 Ω |

AIR LEVELIZER CONTROL MODULE

< ECU DIAGNOSIS INFORMATION >

[AIR LEVELIZER CONTROL SYSTEM]

| Terminal (Wire color) | | Description | | Condition | Reference value (Approx.) |
|--------------------------|-----------|--|------------------|-----------------------|------------------------------|
| + | - | Signal name | Input/ Output | | |
| 5 (W) | Ground | Vehicle height sensor (SIGNAL) | Input | IGN ON | 0.2 – 4.6 V |
| | | | | IGN OFF | 0 V |
| 7 (P) | 16 (L) | CAN-L | Input/ Output | — | 54 – 69 Ω |
| 9 (P/L) | Ground | Air levelizer control module power supply | Input | IGN ON | 10 – 16 V |
| | | | | IGN OFF | 0 V |
| 11 (V/W) | Ground | Exhaust solenoid | Output | IGN ON | 9 – 16 V |
| | | | | Exhaust solenoid: OFF | Less than 2 V |
| 13 (R) | Ground | Vehicle height sensor (Power supply) | Output | IGN ON | 4.5 – 5.5 V |
| | | | | IGN OFF | 0 V |
| 16 (L) | 7 (P) | CAN-H | Input/ Output | — | 54 – 69 Ω |

Fail-safe

INFOID:0000000006256054

If malfunction is detected, control stops.

The system may enter fail-safe mode under certain conditions (for example, over-laden conditions) when electronic circuit is normal.

In this case, always check that the system returns to normal by starting engine after unloading load.

DTC Inspection Priority Chart

INFOID:0000000006256055

If some DTCs are displayed at the same time, perform inspections one by one based on the following priority chart.

| Priority | Detected items (DTC) |
|----------|--|
| 1 | <ul style="list-style-type: none"> • U1000 CAN COMM CIRCUIT • U1010 CONTROL UNIT (CAN) |
| 2 | <ul style="list-style-type: none"> • C1801 VHCL HEIGHT SENSOR • C1802 AIR SUS COMPRS RELAY • C1803 AIR SUS EXH SOL • C1806 VHCL HEIGHT SEN FIX • C1807 VHCL HEIGHT SEN VOLT |
| 3 | <ul style="list-style-type: none"> • C1804 VHCL HEIGHT ADJ UP • C1805 VHCL HEIGHT ADJ DOWN • C1808 AIR SUS COMPRS FNCTN |

DTC Index

INFOID:0000000006256056

| DTC | CONSULT-III display | Reference page |
|-------|----------------------|------------------------|
| C1801 | VHCL HEIGHT SENSOR | SCS-69 |
| C1802 | AIR SUS COMPRS RELAY | SCS-72 |
| C1803 | AIR SUS EXH SOL | SCS-74 |
| C1804 | VHCL HEIGHT ADJ UP | SCS-77 |
| C1805 | VHCL HEIGHT ADJ DOWN | SCS-80 |
| C1806 | VHCL HEIGHT SEN FIX | SCS-81 |
| C1807 | VHCL HEIGHT SEN VOLT | SCS-82 |
| C1808 | AIR SUS COMPRS FNCTN | SCS-84 |

AIR LEVELIZER CONTROL MODULE

< ECU DIAGNOSIS INFORMATION >

[AIR LEVELIZER CONTROL SYSTEM]

| | | |
|-------|--------------------|------------------------|
| U1000 | CAN COMM CIRCUIT | SCS-87 |
| U1010 | CONTROL UNIT (CAN) | SCS-88 |

AIR LEVELIZER CONTROL SYSTEM

[AIR LEVELIZER CONTROL SYSTEM]

< WIRING DIAGRAM >

WIRING DIAGRAM

AIR LEVELIZER CONTROL SYSTEM

Wiring Diagram

INFOID:000000006256057

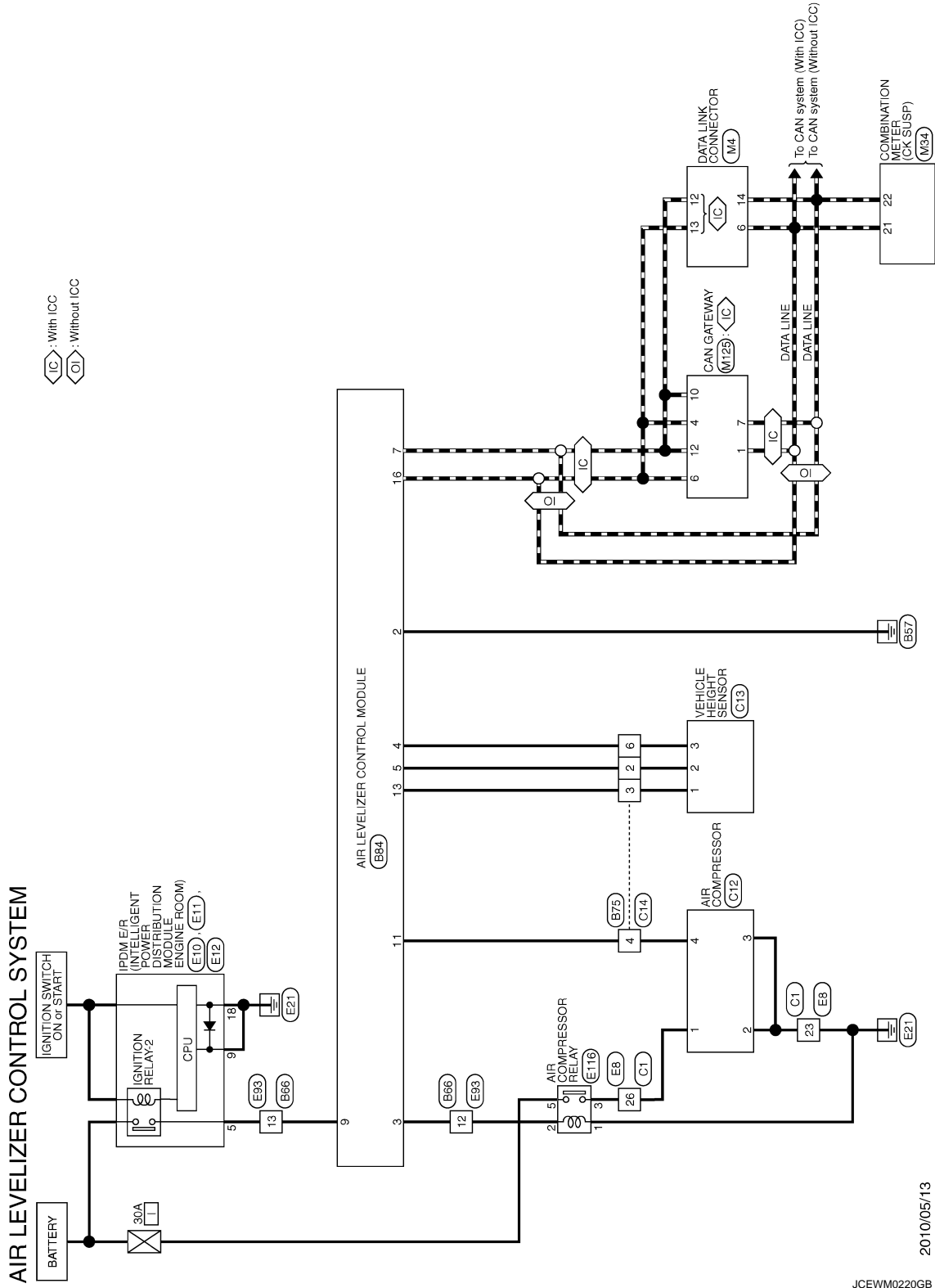

2010/05/13

JCEWM0220GB

SCS

AIR LEVELIZER CONTROL SYSTEM

[AIR LEVELIZER CONTROL SYSTEM]

< WIRING DIAGRAM >

AIR LEVELIZER CONTROL SYSTEM

| | |
|----------------|--------------|
| Connector No. | B66 |
| Connector Name | WIRE TO WIRE |
| Connector Type | TH18MW-NH |

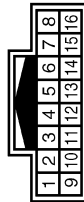

| Terminal No. | Color of Wire | Signal Name [Specification] |
|--------------|---------------|-----------------------------|
| 1 | R | - |
| 2 | B | - |
| 3 | G | - |
| 4 | W | - |
| 5 | SHIELD | - |
| 7 | GR | - |
| 8 | R/W | - |
| 11 | R | - |
| 12 | V | - |
| 13 | P/L | - |
| 15 | R/Y | - |
| 16 | L/W | - |

| | |
|----------------|--------------|
| Connector No. | B75 |
| Connector Name | WIRE TO WIRE |
| Connector Type | RK06FGY |



| Terminal No. | Color of Wire | Signal Name [Specification] |
|--------------|---------------|-----------------------------|
| 1 | W | - |
| 2 | R | - |
| 3 | V/W | - |
| 4 | L/W | - |
| 5 | L/W | - |
| 6 | L/W | - |

| | |
|----------------|------------------------------|
| Connector No. | B84 |
| Connector Name | AIR LEVELIZER CONTROL MODULE |
| Connector Type | TH18FV-NH |



| Terminal No. | Color of Wire | Signal Name [Specification] |
|--------------|---------------|------------------------------------|
| 2 | B | GND |
| 3 | V | AIR COMPRESSOR RELAY |
| 4 | L/W | VEHICLE HEIGHT SENSOR GND |
| 5 | W | VEHICLE HEIGHT SENSOR SIGNAL |
| 7 | P | CAN-L |
| 9 | P/L | IGN |
| 11 | V/W | EXHAUST SOLENOID |
| 13 | R | VEHICLE HEIGHT SENSOR POWER SUPPLY |
| 16 | L | CAN-H |

| | |
|----------------|--------------------|
| Connector No. | C1 |
| Connector Name | WIRE TO WIRE |
| Connector Type | SAA38FB-RS1D-S/J22 |

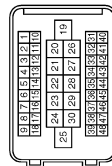

| Terminal No. | Color of Wire | Signal Name [Specification] |
|--------------|---------------|-----------------------------|
| 1 | Y | - |
| 3 | SB | - |
| 4 | L/Y | - |
| 5 | R | - |
| 8 | V | - |
| 9 | P | - |
| 10 | BR/Y | - |
| 11 | Y/V | - |
| 12 | V/W | - |
| 14 | Y/L | - |
| 17 | BR | - |
| 18 | R/O | - |
| 20 | G/W | - |

| | | |
|----|------|---|
| 22 | L/W | - |
| 23 | B | - |
| 24 | Y/G | - |
| 25 | R | - |
| 26 | SB | - |
| 27 | R/G | - |
| 28 | V | - |
| 29 | B | - |
| 40 | LG/R | - |
| 41 | R/G | - |
| 42 | B/R | - |

| | |
|----------------|----------------|
| Connector No. | C12 |
| Connector Name | AIR COMPRESSOR |
| Connector Type | X04FGY |



| Terminal No. | Color of Wire | Signal Name [Specification] |
|--------------|---------------|-------------------------------|
| 1 | SB | AIR COMPRESSOR POWER SUPPLY |
| 2 | B | AIR COMPRESSOR GROUND |
| 3 | B | EXHAUST SOLENOID GROUND |
| 4 | L/W | EXHAUST SOLENOID POWER SUPPLY |

| | |
|----------------|-----------------------|
| Connector No. | C13 |
| Connector Name | VEHICLE HEIGHT SENSOR |
| Connector Type | RK03FB |



| Terminal No. | Color of Wire | Signal Name [Specification] |
|--------------|---------------|-----------------------------|
| 1 | R | 5V |
| 2 | W | SIG |
| 3 | L/W | GND |

| | |
|----------------|--------------|
| Connector No. | C14 |
| Connector Name | WIRE TO WIRE |
| Connector Type | RK08MGY |



| Terminal No. | Color of Wire | Signal Name [Specification] |
|--------------|---------------|-----------------------------|
| 2 | W | - |
| 3 | R | - |
| 4 | L/W | - |
| 6 | L/W | - |

AIR LEVELIZER CONTROL SYSTEM

[AIR LEVELIZER CONTROL SYSTEM]

< WIRING DIAGRAM >

AIR LEVELIZER CONTROL SYSTEM

| | |
|----------------|---------------------|
| Connector No. | E1B |
| Connector Name | WIRE TO WIRE |
| Connector Type | 3AA38MB-RS (0-SJZ2) |

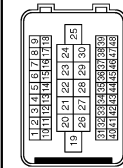

| Terminal No. | Color of Wire | Signal Name [Specification] |
|--------------|---------------|-----------------------------|
| 1 | Y | - |
| 2 | SB | - |
| 3 | L/Y | - |
| 4 | R | - |
| 5 | V | - |
| 6 | P | - |
| 7 | BR/Y | - |
| 8 | Y/V | - |
| 9 | V/W | - |
| 10 | Y/L | - |
| 11 | BR | - |
| 12 | R/Y | - |
| 13 | G/W | - |
| 14 | L/W | - |
| 15 | Y/G | - |
| 16 | B | - |
| 17 | R | - |
| 18 | SB | - |
| 19 | R/G | - |
| 20 | V | - |
| 21 | B | - |
| 22 | LG/R | - |
| 23 | R/G | - |
| 24 | B/R | - |
| 25 | B | - |
| 26 | SB | - |
| 27 | R/G | - |
| 28 | V | - |
| 29 | B | - |
| 30 | LG/R | - |
| 31 | R/G | - |
| 32 | B/R | - |
| 33 | B | - |
| 34 | SB | - |
| 35 | R/G | - |



| | |
|----------------|---|
| Connector No. | E10 |
| Connector Name | IPM E/R INTELLIGENT POWER DISTRIBUTION MODULE (ENGINE ROOM) |
| Connector Type | M06FW-LC |

| Terminal No. | Color of Wire | Signal Name [Specification] |
|--------------|---------------|-----------------------------|
| 3 | R | - |
| 4 | L | - |
| 5 | P/L | - |
| 7 | W/G | - |
| 8 | W | - |

| | |
|----------------|---|
| Connector No. | E11 |
| Connector Name | IPM E/R INTELLIGENT POWER DISTRIBUTION MODULE (ENGINE ROOM) |
| Connector Type | M06FB-LC |



| Terminal No. | Color of Wire | Signal Name [Specification] |
|--------------|---------------|-----------------------------|
| 9 | B | - |
| 14 | L | - |

| | |
|----------------|---|
| Connector No. | E12 |
| Connector Name | IPM E/R INTELLIGENT POWER DISTRIBUTION MODULE (ENGINE ROOM) |
| Connector Type | NS08FBF-CS |



| Terminal No. | Color of Wire | Signal Name [Specification] |
|--------------|---------------|-----------------------------|
| 17 | B | - |
| 18 | B | - |
| 19 | V | - |
| 20 | W | - |
| 21 | L | - |

| | |
|----------------|--------------|
| Connector No. | E13 |
| Connector Name | WIRE TO WIRE |
| Connector Type | T1H16FW-MH |

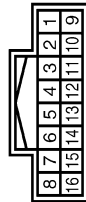

| Terminal No. | Color of Wire | Signal Name [Specification] |
|--------------|---------------|-----------------------------|
| 1 | R | - |
| 2 | B | - |
| 3 | G | - |
| 4 | W | - |
| 5 | SHIELD | - |
| 6 | R/W | - |
| 7 | GR | - |
| 8 | R/W | - |
| 11 | R | - |
| 12 | V | - |
| 13 | P/L | - |
| 15 | R/Y | - |
| 16 | L/W | - |

| | |
|----------------|----------------------|
| Connector No. | E116 |
| Connector Name | AIR COMPRESSOR RELAY |
| Connector Type | 24347 9F500 |



| Terminal No. | Color of Wire | Signal Name [Specification] |
|--------------|---------------|-----------------------------|
| 1 | B | - |
| 2 | V | - |
| 3 | SB | - |
| 5 | Y/B | - |

| | |
|----------------|---------------------|
| Connector No. | M4 |
| Connector Name | DATA LINK CONNECTOR |
| Connector Type | ED16FW |

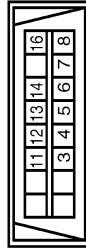

| Terminal No. | Color of Wire | Signal Name [Specification] |
|--------------|---------------|-----------------------------|
| 3 | LG | - |
| 4 | B | - |
| 5 | B | - |
| 6 | B | - |
| 7 | SB | - |
| 8 | SB | - |
| 11 | SB | - |
| 12 | R | - |
| 13 | L | - |
| 14 | P | - |
| 16 | Y | - |

A
B
C
D
SCS
F
G
H
I
J
K
L
M
N
O
P

AIR LEVELIZER CONTROL SYSTEM

< WIRING DIAGRAM >

[AIR LEVELIZER CONTROL SYSTEM]

AIR LEVELIZER CONTROL SYSTEM

| | |
|----------------|-------------------|
| Connector No. | M84 |
| Connector Name | COMBINATION METER |
| Connector Type | TH40FV-NH |



| | | | | | | | | | | | | | | | | | | | | | | | | | | | | | | | | | | | | | | | |
|---|---|---|---|---|---|---|---|---|----|----|----|----|----|----|----|----|----|----|----|----|----|----|----|----|----|----|----|----|----|----|----|----|----|----|----|----|----|----|----|
| 1 | 2 | 3 | 4 | 5 | 6 | 7 | 8 | 9 | 10 | 11 | 12 | 13 | 14 | 15 | 16 | 17 | 18 | 19 | 20 | 21 | 22 | 23 | 24 | 25 | 26 | 27 | 28 | 29 | 30 | 31 | 32 | 33 | 34 | 35 | 36 | 37 | 38 | 39 | 40 |
|---|---|---|---|---|---|---|---|---|----|----|----|----|----|----|----|----|----|----|----|----|----|----|----|----|----|----|----|----|----|----|----|----|----|----|----|----|----|----|----|

| Terminal No. | Color of Wire | Signal Name [Specification] |
|--------------|---------------|--|
| 1 | Y | BATTERY POWER SUPPLY |
| 2 | GR | IGNITION SIGNAL |
| 3 | B | GROUND |
| 4 | B | GROUND |
| 5 | B | ILL. GND |
| 7 | R | LOW MODE SIGNAL |
| 8 | P/L | TRIP RESET SWITCH SIGNAL |
| 11 | G | ENTER SWITCH SIGNAL |
| 12 | O | SELECT SWITCH SIGNAL |
| 13 | W/R | ILLUMINATION CONTROL SWITCH SIGNAL (+) |
| 14 | R | ILLUMINATION CONTROL SWITCH SIGNAL (-) |
| 15 | R/W | AIR BAG SIGNAL |
| 18 | W/R | AMBIENT SENSOR SIGNAL |
| 19 | V/W | A/C AUTO AMP. CONNECTION RECOGNITION SIGNAL |
| 20 | B | AMBIENT SENSOR GROUND |
| 21 | L | CAN-H |
| 22 | P | CAN-L |
| 23 | B | GROUND |
| 24 | V | FUEL LEVEL SENSOR GROUND |
| 25 | O/L | ALTERNATOR SIGNAL |
| 26 | W | PARKING BRAKE SWITCH SIGNAL |
| 28 | GR/R | SECURITY SIGNAL |
| 29 | BR | WASHER LEVEL SWITCH SIGNAL |
| 30 | SB | VEHICLE SPEED SIGNAL (2-PULSE) |
| 31 | BR/W | VEHICLE SPEED SIGNAL (8-PULSE) |
| 33 | W | SNOW MODE SIGNAL |
| 34 | BR/Y | FUEL LEVEL SENSOR SIGNAL |
| 35 | O/B | SEAT BELT BUCKLE SWITCH SIGNAL (DRIVER SIDE) |
| 36 | G/Y | PASSENGER SEAT BELT WARNING SIGNAL |
| 37 | R/Y | NON-MANUAL MODE SIGNAL |
| 38 | L/W | MANUAL MODE SHIFT DOWN SIGNAL |
| 39 | Y/B | MANUAL MODE SHIFT UP SIGNAL |
| 40 | G/W | MANUAL MODE SIGNAL |

| | |
|----------------|-------------|
| Connector No. | M125 |
| Connector Name | CAN GATEWAY |
| Connector Type | TH12FV-NH |



| | | | | | | | | | | | |
|---|---|---|---|---|---|---|---|---|----|----|----|
| 1 | 2 | 3 | 4 | 5 | 6 | 7 | 8 | 9 | 10 | 11 | 12 |
|---|---|---|---|---|---|---|---|---|----|----|----|

| Terminal No. | Color of Wire | Signal Name [Specification] |
|--------------|---------------|-----------------------------|
| 1 | L | CAN-H |
| 3 | Y | BATTERY |
| 4 | L | CAN-H |
| 5 | B | GND |
| 6 | L | CAN-H |
| 7 | P | CAN-H |
| 9 | GR | IGNITION |
| 10 | R | CAN-L |
| 11 | B | GND |
| 12 | R | CAN-L |

BASIC INSPECTION

DIAGNOSIS AND REPAIR WORKFLOW

Work Flow

INFOID:000000006256058

DETAILED FLOW

1. INTERVIEW FROM THE CUSTOMER

Clarify customer complaints before inspection. First of all, perform an interview utilizing [SCS-66, "Diagnostic Work Sheet"](#) and reproduce the symptom as well as fully understand it. Ask customer about his/her complaints carefully. Check symptoms by driving vehicle with customer, if necessary.

CAUTION:

Customers are not professional. Never guess easily like "maybe the customer means that..." or "maybe the customer mentions this symptom".

>> GO TO 2.

2. CHECK SYMPTOM

Reproduce the symptom that is indicated by the customer, based on the information from the customer obtained by interview. Also check that the symptom is not caused by fail-safe mode. Refer to [SCS-59, "Fail-safe"](#).

CAUTION:

When the symptom is caused by normal operation, fully inspect each portion and obtain the understanding of customer that the symptom is not caused by a malfunction.

>> GO TO 3.

3. PERFORM THE SELF-DIAGNOSIS

 With CONSULT-III

Perform self-diagnosis for "E-SUS".

Is any DTC detected?

YES >> Record or print self-diagnosis results. GO TO 4.

NO >> GO TO 6.

4. RECHECK THE SYMPTOM

 With CONSULT-III

1. Erase self-diagnostic results for "E-SUS".

2. Perform DTC confirmation procedures for the error-detected system.

NOTE:

If some DTCs are detected at the same time, determine the order for performing the diagnosis based on [SCS-59, "DTC Inspection Priority Chart"](#).

Is any DTC detected?

YES >> GO TO 5.

NO >> Check harness and connectors based on the information obtained by interview. Refer to [GI-40, "Intermittent Incident"](#).

5. REPAIR OR REPLACE ERROR-DETECTED PART

- Repair or replace error-detected parts.
- Reconnect part or connector after repairing or replacing.
- When DTC is detected, erase self-diagnostic result for "E-SUS".

>> GO TO 7.

6. IDENTIFY ERROR-DETECTED SYSTEM BY SYMPTOM DIAGNOSIS

Estimate error-detected system based on symptom diagnosis and perform inspection.

Can the error-detected system be identified?

DIAGNOSIS AND REPAIR WORKFLOW

[AIR LEVELIZER CONTROL SYSTEM]

< BASIC INSPECTION >

YES >> GO TO 7.

NO >> Check harness and connectors based on the information obtained by interview. Refer to [GI-40](#), "[Intermittent Incident](#)".

7. FINAL CHECK

④ With CONSULT-III

1. Check the reference value for "E-SUS".

2. Recheck the symptom and check that the symptom is not reproduced on the same conditions.

Is the symptom reproduced?

YES >> GO TO 3.

NO >> INSPECTION END

Diagnostic Work Sheet

INFOID:000000006256059

Description

- In general, customers have their own criteria for a problem. Therefore, it is important to understand the symptom and status well enough by asking the customer about his/her concerns carefully. To systemize all the information for the diagnosis, prepare the interview sheet referring to the interview points.
- In some cases, multiple conditions that appear simultaneously may cause a DTC to be detected.

INTERVIEW SHEET SAMPLE

| Interview sheet | | | | | |
|---------------------------|-------|--|--|-------------------------------------|---------|
| Customer name | MR/MS | Registration number | | Initial year registration | |
| | | Vehicle type | | VIN | |
| Storage date | | Engine | | Mileage | km/Mile |
| Symptom | | <input type="checkbox"/> Does not operate () function | | | |
| | | <input type="checkbox"/> Warning lamp for () turns ON | | | |
| | | <input type="checkbox"/> Noise | | <input type="checkbox"/> Vibration | |
| | | <input type="checkbox"/> Other () | | | |
| First occurrence | | <input type="checkbox"/> Recently <input type="checkbox"/> Other () | | | |
| Frequency of occurrence | | <input type="checkbox"/> Always <input type="checkbox"/> Under a certain conditions of <input type="checkbox"/> Sometimes (time/day) | | | |
| Climate conditions | | <input type="checkbox"/> Irrelevant | | | |
| | | Weather | <input type="checkbox"/> Fine <input type="checkbox"/> Cloud <input type="checkbox"/> Rain <input type="checkbox"/> Snow <input type="checkbox"/> Others () | | |
| | | Temperature | <input type="checkbox"/> Hot <input type="checkbox"/> Warm <input type="checkbox"/> Cool <input type="checkbox"/> Cold <input type="checkbox"/> Temp. [Approx. °C (°F)] | | |
| Relative humidity | | <input type="checkbox"/> High <input type="checkbox"/> Moderate <input type="checkbox"/> Low | | | |
| Road conditions | | <input type="checkbox"/> Urban area <input type="checkbox"/> Suburb area | | <input type="checkbox"/> Highway | |
| | | <input type="checkbox"/> Mountainous road (uphill or downhill) | | <input type="checkbox"/> Rough road | |
| Operating condition, etc. | | <input type="checkbox"/> Irrelevant <input type="checkbox"/> When engine starts <input type="checkbox"/> During idling <input type="checkbox"/> During driving <input type="checkbox"/> During acceleration <input type="checkbox"/> At constant speed driving <input type="checkbox"/> During deceleration <input type="checkbox"/> During cornering (right curve or left curve) <input type="checkbox"/> When steering wheel is steered (to right or to left) | | | |
| Memo | | | | | |

STANDARD VEHICLE HEIGHT SETTING

[AIR LEVELIZER CONTROL SYSTEM]

< BASIC INSPECTION >

STANDARD VEHICLE HEIGHT SETTING

Description

INFOID:000000006256060

Air levelizer control module enables precise control, by acquiring memorized standard vehicle height and signal (vehicle height) from vehicle height sensor. For this reason, always set standard vehicle height after performing the following operations.

- Removal and installation or replacement of vehicle height sensor
- Replacement of air levelizer control module

Work Procedure

INFOID:000000006256061

1. CLEAR STANDARD VEHICLE HEIGHT

④ With CONSULT-III

1. Lift up the vehicle.

CAUTION:

Check that tires never contact the ground.

2. Start the engine.
3. Select "COMPRESSOR" in "Active Test" in "E-SUS".
4. Touch "ON" and wait 60 seconds or more.
5. Touch "OFF".
6. Select "CLEAR HEIGHT INI" in "Work Support" in "E-SUS".
7. Touch "Start".
8. Touch "Clear".

NOTE:

CONSULT-III continues indicating "EXECUTING". The completion of the standard vehicle height erasing can be checked by the CK SUSP indicator lamp ON condition.

Does CK SUSP indicator lamp turn ON?

YES >> GO TO 2.

NO >> Perform step 1 again.

2. ADJUST STANDARD VEHICLE HEIGHT

④ With CONSULT-III

1. Select "ADJUST HEIGHT INI" in "Work Support" in "E-SUS".
2. Touch "Start".
3. Touch "Initial 1".

NOTE:

CONSULT-III continues indicating "EXECUTING". The completion of the standard vehicle height adjustment can be checked by the CK SUSP indicator lamp OFF condition.

Does CK SUSP indicator lamp turn OFF?

YES >> GO TO 3.

NO >> Perform step 1 again.

3. ADJUST VEHICLE HEIGHT

④ With CONSULT-III

1. Lift down the vehicle.

CAUTION:

Check that the lift is fully lowered.

2. Select "STANDARD HEIGHT LEVEL" in "Work Support" in "E-SUS".
3. Touch "Start".
4. Touch "Revert" and wait 120 seconds or more.
5. Although CONSULT-III continues indicating "EXECUTING", select "VHCL HGT CNVSN VL" in "Data Monitor" in "E-SUS".

Is value within -15 – 15 mm?

YES >> GO TO 4.

NO >> Perform step 1 again.

4. CHECK DTC

④ With CONSULT-III

A

B

C

D

SCS

F

G

H

I

J

K

L

M

N

O

P

STANDARD VEHICLE HEIGHT SETTING

[AIR LEVELIZER CONTROL SYSTEM]

< BASIC INSPECTION >

Select "Self Diagnostic Results" in "E-SUS".

Is any DTC detected?

YES >> Refer to [SCS-59. "DTC Index"](#).

NO >> SETTING END

C1801 VHCL HEIGHT SENSOR

< DTC/CIRCUIT DIAGNOSIS >

[AIR LEVELIZER CONTROL SYSTEM]

DTC/CIRCUIT DIAGNOSIS

C1801 VHCL HEIGHT SENSOR

DTC Logic

INFOID:000000006256062

DTC DETECTION LOGIC

| DTC | Display item1 | Malfunction detected condition | Possible cause |
|-------|--------------------|--|---|
| C1801 | VHCL HEIGHT SENSOR | Signal voltage of the vehicle height sensor remains 0.2 V or less or 4.6 V or more continuously for 60 seconds during sensor voltage (4.5 – 5.5 V) output by the air levelizer control module. | <ul style="list-style-type: none"> • Harness or connectors (Sensor circuit is open.) • Vehicle height sensor • Air levelizer control module • Rear suspension component parts |

DTC CONFIRMATION PROCEDURE

1. PRECONDITIONING

If "DTC CONFIRMATION PROCEDURE" has been previously conducted, always turn ignition switch OFF and wait at least 10 seconds before conducting the next test.

>> GO TO 2.

2. CHECK DTC DETECTION

Ⓜ With CONSULT-III

1. Turn ignition switch ON and wait 60 seconds or more.
2. Perform "Self Diagnostic Results" in "E-SUS".

Is "C1801" detected?

- YES >> Go to [SCS-69, "Diagnosis Procedure"](#).
 NO >> INSPECTION END

Diagnosis Procedure

INFOID:000000006256063

1. CHECK APPEARANCE

Visually check for malfunction of suspension components, installing malfunction, or deformation of vehicle height sensor.

Is the inspection result normal?

- YES >> GO TO 2.
 NO >> Repair or replace damaged parts.

2. CHECK POWER SUPPLY CIRCUIT (PART 1)

1. Disconnect vehicle height sensor connector.
2. Turn ignition switch ON.
CAUTION:
Never start the engine.
3. Check voltage between vehicle height sensor harness connector and ground.

| Vehicle height sensor | | — | Voltage |
|-----------------------|----------|--------|-------------|
| Connector | Terminal | | |
| C13 | 1 | Ground | 4.5 – 5.5 V |

Is the inspection result normal?

- YES >> GO TO 4.
 NO >> GO TO 3.

3. CHECK POWER SUPPLY CIRCUIT (PART 2)

1. Turn ignition switch OFF.
2. Disconnect air levelizer control module connector.

C1801 VHCL HEIGHT SENSOR

[AIR LEVELIZER CONTROL SYSTEM]

< DTC/CIRCUIT DIAGNOSIS >

3. Check continuity between air levelizer control module harness connector and vehicle height sensor harness connector.

| Air levelizer control module | | Vehicle height sensor | | Continuity |
|------------------------------|----------|-----------------------|----------|------------|
| Connector | Terminal | Connector | Terminal | |
| B84 | 13 | C13 | 1 | Existed |

4. Check continuity between air levelizer control module harness connector and ground.

| Air levelizer control module | | — | Continuity |
|------------------------------|----------|--------|-------------|
| Connector | Terminal | | |
| B84 | 13 | Ground | Not existed |

Is the inspection result normal?

- YES >> 1. Check intermittent incident. Refer to [GI-40, "Intermittent Incident"](#).
2. If inspection result is OK, replace the air levelizer control module. Refer to [SCS-94, "Removal and Installation"](#).

NO >> Repair or replace damaged parts.

4.CHECK HARNESS BETWEEN AIR LEVELIZER CONTROL MODULE AND VEHICLE HEIGHT SENSOR

- Turn ignition switch OFF.
- Disconnect air levelizer control module connector.
- Check continuity between air levelizer control module harness connector and vehicle height sensor harness connector.

| Air levelizer control module | | Vehicle height sensor | | Continuity |
|------------------------------|----------|-----------------------|----------|------------|
| Connector | Terminal | Connector | Terminal | |
| B84 | 5 | C13 | 2 | Existed |
| | 4 | | 3 | |

4. Check continuity between air levelizer control module harness connector and ground.

| Air levelizer control module | | — | Continuity |
|------------------------------|----------|--------|-------------|
| Connector | Terminal | | |
| B84 | 5 | Ground | Not existed |
| | 4 | | |

Are the inspection results normal?

YES >> GO TO 5.

NO >> Repair or replace damaged parts.

5.CHECK VEHICLE HEIGHT SENSOR

Check the vehicle height sensor. Refer to [SCS-70, "Component Inspection"](#).

Is the inspection result normal?

YES >> GO TO 6.

NO >> Replace the vehicle height sensor. Refer to [SCS-98, "Removal and Installation"](#).

6.CHECK INTERMITTENT INCIDENT

Refer to [GI-40, "Intermittent Incident"](#).

Is the inspection result normal?

YES >> Replace the air levelizer control module. Refer to [SCS-94, "Removal and Installation"](#).

NO >> Repair or replace damaged parts.

Component Inspection

INFOID:000000006256064

1.CHECK VEHICLE HEIGHT SENSOR

C1801 VHCL HEIGHT SENSOR

[AIR LEVELIZER CONTROL SYSTEM]

< DTC/CIRCUIT DIAGNOSIS >

1. Remove the vehicle height sensor. Refer to [SCS-98, "Removal and Installation"](#).
2. Check resistance between vehicle height sensor connector terminals.

| Vehicle height sensor | | Condition | Resistance (Approx.) |
|-----------------------|---|------------|----------------------|
| Terminal | | | |
| 1 | 2 | A position | 1.9 – 3.0 kΩ |
| | | B position | 320 – 680 Ω |
| 1 | 3 | Always | 1.6 – 2.4 kΩ |
| 2 | 3 | A position | 320 – 680 Ω |
| | | B position | 1.9 – 3.0 kΩ |

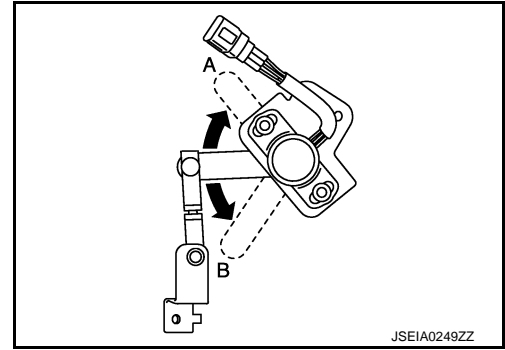

Are the inspection results normal?

- YES >> 1. Install the vehicle height sensor. Refer to [SCS-94, "Removal and Installation"](#).
 2. Perform "STANDARD VEHICLE HEIGHT SETTING". Refer to [SCS-67, "Work Procedure"](#).
- NO >> Replace the vehicle height sensor. Refer to [SCS-98, "Removal and Installation"](#).

A
B
C
D
SCS
F
G
H
I
J
K
L
M
N
O
P

C1802 AIR SUS COMPRS RELAY

< DTC/CIRCUIT DIAGNOSIS >

[AIR LEVELIZER CONTROL SYSTEM]

C1802 AIR SUS COMPRS RELAY

DTC Logic

INFOID:000000006256065

DTC DETECTION LOGIC

| DTC | Display item | Malfunction detected condition | Possible cause |
|-------|----------------------|--|--|
| C1802 | AIR SUS COMPRS RELAY | <ul style="list-style-type: none"> Output voltage of the air compressor relay remains 9 V or less continuously for 5 seconds during air compressor ON signal output by the air levelizer control module. Output voltage of the air compressor relay remains 2 V or more continuously for 10 seconds during air compressor OFF signal output by the air levelizer control module. | <ul style="list-style-type: none"> Harness or connector Air compressor relay Air levelizer control module |

DTC CONFIRMATION PROCEDURE

1. PRECONDITIONING

If "DTC CONFIRMATION PROCEDURE" has been previously conducted, always turn ignition switch OFF and wait at least 10 seconds before conducting the next test.

>> GO TO 2.

2. CHECK DTC DETECTION

④ With CONSULT-III

- Turn ignition switch ON and wait 10 seconds or more.
- Select "COMPRESSOR" in "Active Test" in "E-SUS".
- Touch "ON" and wait 5 seconds or more.
- Select "Self Diagnostic Result" in "E-SUS".

Is "C1802" detected ?

YES >> Go to [SCS-72, "Diagnosis Procedure"](#).

NO >> INSPECTION END

Diagnosis Procedure

INFOID:000000006256066

1. CHECK AIR COMPRESSOR ON SIGNAL FROM AIR LEVELIZER CONTROL MODULE

④ CONSULT-III

- Disconnect air compressor relay connector.
- Turn ignition switch ON.

CAUTION:

Never start the engine.

- Select "COMPRESSOR" in "Active Test" in "E-SUS".
- Touch "ON".
- While operating test item, check voltage between air compressor relay harness connector and ground.

| Air compressor relay | | — | Voltage |
|----------------------|----------|--------|----------|
| Connector | Terminal | | |
| E116 | 2 | Ground | 9 – 16 V |

Is the inspection result normal?

YES >> GO TO 4.

NO >> GO TO 2.

2. CHECK HARNESS BETWEEN AIR LEVELIZER CONTROL MODULE AND AIR COMPRESSOR RELAY

- Turn ignition switch OFF.
- Disconnect air levelizer control module connector.

C1802 AIR SUS COMPRS RELAY

[AIR LEVELIZER CONTROL SYSTEM]

< DTC/CIRCUIT DIAGNOSIS >

3. Check continuity between air levelizer control module harness connector and air compressor relay harness connector.

| Air levelizer control module | | Air compressor relay | | Continuity |
|------------------------------|----------|----------------------|----------|------------|
| Connector | Terminal | Connector | Terminal | |
| B84 | 3 | E116 | 2 | Existed |

4. Check continuity between air levelizer control module harness connector and ground.

| Air levelizer control module | | — | Continuity |
|------------------------------|----------|--------|-------------|
| Connector | Terminal | | |
| B84 | 3 | Ground | Not existed |

5. Check voltage between air levelizer control module harness connector and ground.

| Air levelizer control module | | — | Voltage |
|------------------------------|----------|--------|---------|
| Connector | Terminal | | |
| B84 | 3 | Ground | 0 V |

Are the inspection results normal?

- YES >> GO TO 3.
 NO >> Repair or replace damaged part.

3.CHECK INTERMITTENT INCIDENT

Refer to [GI-40. "Intermittent Incident"](#).

Is the inspection result normal?

- YES >> Replace the air levelizer control module. Refer to [SCS-94. "Removal and Installation"](#).
 NO >> Repair or replace damaged parts.

4.CHECK AIR COMPRESSOR RELAY GROUND

1. Turn ignition switch OFF.
 2. Check continuity between air compressor relay harness connector and ground.

| Air compressor relay | | — | Continuity |
|----------------------|----------|--------|------------|
| Connector | Terminal | | |
| E116 | 1 | Ground | Existed |

Is the inspection result normal?

- YES >> GO TO 5.
 NO >> Repair or replace damaged part.

5.CHECK AIR COMPRESSOR RELAY

1. Remove the air compressor relay. Refer to [SCS-50. "Component Parts Location"](#).
 2. Check continuity between air compressor relay harness connector terminals.

| Air compressor relay | | Continuity |
|----------------------|---|------------|
| Terminal | | |
| 1 | 2 | Existed |

Is the inspection result normal?

- YES >> Check intermittent incident. Refer to [GI-40. "Intermittent Incident"](#).
 NO >> Replace the air compressor relay. Refer to [SCS-50. "Component Parts Location"](#).

A
B
C
D
SCS
F
G
H
I
J
K
L
M
N
O
P

C1803 AIR SUSPENSION EXH SOL

< DTC/CIRCUIT DIAGNOSIS >

[AIR LEVELIZER CONTROL SYSTEM]

C1803 AIR SUSPENSION EXH SOL

DTC Logic

INFOID:000000006256067

DTC DETECTION LOGIC

| DTC | Display item | Malfunction detected condition | Possible cause |
|-------|-----------------|--|--|
| C1803 | AIR SUS EXH SOL | <ul style="list-style-type: none">Output voltage of the exhaust solenoid remains 9 V or less continuously for 5 seconds during exhaust solenoid ON signal output by the air levelizer control module.Output voltage of the exhaust solenoid remains 2 V or more continuously for 10 seconds during exhaust solenoid ON signal output by the air levelizer control module. | <ul style="list-style-type: none">Harness or connectorExhaust solenoidAir levelizer control module |

DTC CONFIRMATION PROCEDURE

1. PRECONDITIONING

If "DTC CONFIRMATION PROCEDURE" has been previously conducted, always turn ignition switch OFF and wait at least 10 seconds before conducting the next test.

>> GO TO 2.

2. CHECK DTC DETECTION

④ With CONSULT-III

- Turn ignition switch ON and wait 10 seconds or more.
- Select "EXHAUST SOLENOID" in "Active Test" in "E-SUS".
- Touch "ON" and wait 5 seconds or more.
- Select "Self Diagnostic Result" in "E-SUS".

Is "C1803" detected ?

YES >> Go to [SCS-74, "Diagnosis Procedure"](#).

NO >> INSPECTION END

Diagnosis Procedure

INFOID:000000006256068

1. CHECK EXHAUST SOLENOID ON SIGNAL FROM AIR LEVELIZER CONTROL MODULE

④ CONSULT-III

- Disconnect air compressor harness connector.
- Turn ignition switch ON.
CAUTION:
Never start the engine.
- Select "EXHAUST SOLENOID" in "Active Test" in "E-SUS".
- Touch "ON".
- While operating test item, check voltage between air compressor harness connector and ground.

| Air compressor | | — | Voltage |
|----------------|----------|--------|----------|
| Connector | Terminal | | |
| C12 | 4 | Ground | 9 – 16 V |

Is the inspection result normal?

YES >> GO TO 4.

NO >> GO TO 2.

2. CHECK HARNESS BETWEEN AIR LEVELIZER CONTROL MODULE AND AIR COMPRESSOR

- Turn ignition switch OFF.
- Disconnect air levelizer control module harness connector.

C1803 AIR SUSPENSION EXH SOL

[AIR LEVELIZER CONTROL SYSTEM]

< DTC/CIRCUIT DIAGNOSIS >

3. Check continuity between air levelizer control module harness connector and air compressor harness connector.

| Air levelizer control module | | Air compressor | | Continuity |
|------------------------------|----------|----------------|----------|------------|
| Connector | Terminal | Connector | Terminal | |
| B84 | 11 | C12 | 4 | Existed |

4. Check continuity between air levelizer control module harness connector and ground.

| Air levelizer control module | | — | Continuity |
|------------------------------|----------|--------|-------------|
| Connector | Terminal | | |
| B84 | 11 | Ground | Not existed |

Are the inspection results normal?

YES >> GO TO 3.

NO >> Repair or replace damaged part.

3.CHECK INTERMITTENT INCIDENT

Refer to [GI-40, "Intermittent Incident"](#).

Is the inspection result normal?

YES >> Replace the air levelizer control module. Refer to [SCS-94, "Removal and Installation"](#).

NO >> Repair or replace damaged parts.

4.CHECK AIR COMPRESSOR GROUND

- Turn ignition switch OFF.
- Check continuity between air compressor harness connector and ground.

| Air compressor | | — | Continuity |
|----------------|----------|--------|------------|
| Connector | Terminal | | |
| C12 | 3 | Ground | Existed |

Are the inspection results normal?

YES >> GO TO 5.

NO >> Repair or replace damaged part.

5.CHECK AIR COMPRESSOR (EXHAUST SOLENOID)

Check the air compressor (exhaust solenoid). Refer to [SCS-75, "Component Inspection"](#).

Is the inspection result normal?

YES >> Check intermittent incident. Refer to [GI-40, "Intermittent Incident"](#).

NO >> Replace the air compressor. Refer to [SCS-95, "Removal and Installation"](#).

Component Inspection

INFOID:000000006256069

CAUTION:

- Keep the inside of air compressor free of dust.
- Keep the resin stick and resin pipe free of scratches and burrs.

1.CHECK AIR COMPRESSOR (EXHAUST SOLENOID)

- Remove the air compressor. Refer to [SCS-95, "Removal and Installation"](#).

C1803 AIR SUSPENSION EXH SOL

[AIR LEVELIZER CONTROL SYSTEM]

< DTC/CIRCUIT DIAGNOSIS >

2. Insert resin stick (A) 4.7 mm (0.185 in) in diameter into either one of the air compressor air tube holes to prevent leakage of air.
3. Insert resin pipe (B) 4.7 mm (0.185 in) in diameter into the other air tube hole and install air gauge (C) on the tip of the pipe.
4. Apply 12 V between air compressor connector terminal 1 and 2 until the air gauge reading reaches approximately 500 mm Hg (0.67 MPa).

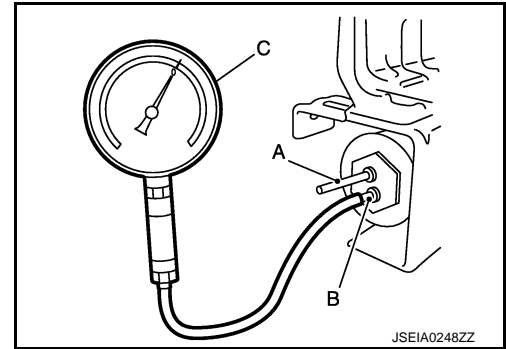

CAUTION:

- Never make the terminals short.
- Connect the fuse between the terminals when applying the voltage.

| (+) (fuse) | (-) | Condition | Status |
|-------------------------|-----|--|---|
| Air compressor Terminal | | | |
| 1 | 2 | Apply 12 V between air compressor connector terminal 1 and 2 until the air gauge reading reaches approximately 500 mm Hg (0.67 MPa). | Air gauge needle remains at the pressurized position. |

5. Apply 12 V between air compressor connector terminal 3 and 4 for approximately 2 seconds.

CAUTION:

- Never make the terminals short.
- Connect the fuse between the terminals when applying the voltage.

| (+) (fuse) | (-) | Condition | Status |
|-------------------------|-----|---|---|
| Air compressor Terminal | | | |
| 4 | 3 | Apply 12 V between air compressor connector terminal 3 and 4 for approximately 2 seconds. | Air gauge reading lowers and the needle stops moving. |

*: It takes approximately 2 minutes for the air gauge needle to stop moving.

Is the inspection result normal?

YES >> INSPECTION END

NO >> Replace the air compressor. Refer to [SCS-95. "Removal and Installation"](#).

C1804 VHCL HEIGHT ADJ UP

< DTC/CIRCUIT DIAGNOSIS >

[AIR LEVELIZER CONTROL SYSTEM]

C1804 VHCL HEIGHT ADJ UP

DTC Logic

INFOID:000000006256070

DTC DETECTION LOGIC

| DTC | Display item | Malfunction detected condition | Possible cause |
|-------|--------------------|--|---|
| C1804 | VHCL HEIGHT ADJ UP | The vehicle height is 15 mm (0.59 in) or more lower than the reference height despite the output of air compressor ON signal continuously for 120 seconds by the air levelizer control module. | <ul style="list-style-type: none">• Harness or connector• Air compressor• Air compressor relay• Air levelizer control module• Rear shock absorber (air chamber)• Vehicle height sensor• Air tube• Rear suspension component parts• Overloaded |

DTC CONFIRMATION PROCEDURE

1. PRECONDITIONING

If "DTC CONFIRMATION PROCEDURE" has been previously conducted, always turn ignition switch OFF and wait at least 10 seconds before conducting the next test.

>> GO TO 2.

2. CHECK DTC DETECTION

Ⓜ With CONSULT-III

1. Set vehicle in the unloaded vehicle status.
2. Start the engine and wait 150 seconds or more.
3. Perform "Self Diagnostic Result" in "E-SUS".

Is "C1804" detected ?

- YES >> Go to [SCS-77. "Diagnosis Procedure"](#).
NO >> INSPECTION END

Diagnosis Procedure

INFOID:000000006256071

1. CHECK APPEARANCE

Visually check for malfunction of suspension components, damage of air chamber of rear shock absorber, installation malfunction, or deformation of vehicle height sensor.

Is the inspection result normal?

- YES >> GO TO 2.
NO >> Repair or replace damaged parts.

2. CHECK AIR LEAK

Apply soapy water to air tube, connecting portions between air tube and each component, and air chamber of rear shock absorber. Check for air leakage.

Is the inspection result normal?

- YES >> GO TO 3.
NO >> Repair or replace damaged parts.

3. CHECK AIR COMPRESSOR RELAY POWER SUPPLY

1. Turn ignition switch OFF.
2. Check 30A fuse (#1).
3. Disconnect air compressor relay connector.
4. Check voltage between air compressor relay harness connector and ground.

C1804 VHCL HEIGHT ADJ UP

< DTC/CIRCUIT DIAGNOSIS >

[AIR LEVELIZER CONTROL SYSTEM]

| Air compressor relay | | — | Voltage |
|----------------------|----------|--------|-----------------|
| Connector | Terminal | | |
| E116 | 5 | Ground | Battery voltage |

Is the inspection result normal?

YES >> GO TO 4.

NO >> Repair or replace damaged part.

4.CHECK AIR COMPRESSOR RELAY OUTPUT CIRCUIT

1. Turn ignition switch OFF.
2. Disconnect air compressor connector.
3. Check continuity between air compressor relay harness connector and air compressor harness connector.

| Air compressor relay | | Air compressor | | Continuity |
|----------------------|----------|----------------|----------|------------|
| Connector | Terminal | Connector | Terminal | |
| E116 | 3 | C12 | 1 | Existed |

4. Check continuity between air compressor relay harness connector and ground.

| Air compressor relay | | — | Continuity |
|----------------------|----------|--------|-------------|
| Connector | Terminal | | |
| E116 | 3 | Ground | Not existed |

Are the inspection results normal?

YES >> GO TO 5.

NO >> Repair or replace damaged part.

5.CHECK AIR COMPRESSOR GROUND

Check continuity between air compressor harness connector and ground.

| Air compressor | | — | Continuity |
|----------------|----------|--------|------------|
| Connector | Terminal | | |
| C12 | 2 | Ground | Existed |

Are the inspection results normal?

YES >> GO TO 6.

NO >> Repair or replace damaged part.

6.CHECK AIR COMPRESSOR RELAY

Check the air compressor relay. Refer to [SCS-79, "Component Inspection \(Air Compressor Relay\)"](#).

Is the inspection result normal?

YES >> GO TO 7.

NO >> Replace the air compressor relay.

7.CHECK AIR COMPRESSOR

Check the air compressor. Refer to [SCS-79, "Component Inspection \(Air Compressor\)"](#).

Is the inspection result normal?

YES >> GO TO 8.

NO >> Replace the air compressor. Refer to [SCS-95, "Removal and Installation"](#).

8.CHECK INTERMITTENT INCIDENT

Refer to [GI-40, "Intermittent Incident"](#).

Is the inspection result normal?

- YES >>
1. Perform "STANDARD VEHICLE HEIGHT SETTING". Refer to [SCS-67, "Work Procedure"](#).
 2. If DTC is detected, replace the air levelizer control module. Refer to [SCS-94, "Removal and Installation"](#).

C1804 VHCL HEIGHT ADJ UP

[AIR LEVELIZER CONTROL SYSTEM]

< DTC/CIRCUIT DIAGNOSIS >

NO >> Repair or replace damaged part.

Component Inspection (Air Compressor Relay)

INFOID:000000006256072

1. CHECK AIR COMPRESSOR RELAY

1. Remove the air compressor relay. Refer to [SCS-50. "Component Parts Location"](#).
2. Apply 12 V direct current between air compressor relay terminals 1 and 2.
CAUTION:
 - **Never make the terminals short.**
 - **Connect the fuse between the terminals when applying the voltage.**
3. Check continuity between air compressor relay terminals 3 and 5.

| (+) (fuse) | (-) | Condition | Continuity |
|----------------------|-----|---|-------------|
| Air compressor relay | | | |
| Terminal | | | |
| 2 | 1 | Apply 12 V direct current between terminals 2 and 1. | Existed |
| — | — | Does not apply 12 V direct current between terminals 2 and 1. | Not existed |

Is the inspection result normal?

YES >> INSPECTION END

NO >> Replace the air compressor relay. Refer to [SCS-50. "Component Parts Location"](#).

Component Inspection (Air Compressor)

INFOID:000000006256073

CAUTION:

Keep the inside of air compressor free of dust.

1. CHECK AIR COMPRESSOR

1. Remove the air compressor. Refer to [SCS-95. "Removal and Installation"](#).
2. Apply 12 V direct current between air compressor terminals 1 and 2.
CAUTION:
 - **Never make the terminals short.**
 - **Connect the fuse between the terminals when applying the voltage.**

| (+) (fuse) | (-) | Condition | Status |
|----------------|-----|--|-----------------------------------|
| Air compressor | | | |
| Terminal | | | |
| 1 | 2 | Apply 12 V direct current between terminals 1 and 2. | Air flows from air exhaust holes. |

Is the inspection result normal?

YES >> INSPECTION END

NO >> Replace the air compressor. Refer to [SCS-95. "Removal and Installation"](#).

C1805 VHCL HEIGHT ADJ DOWN

< DTC/CIRCUIT DIAGNOSIS >

[AIR LEVELIZER CONTROL SYSTEM]

C1805 VHCL HEIGHT ADJ DOWN

DTC Logic

INFOID:000000006256074

DTC DETECTION LOGIC

| DTC | Display item | Malfunction detected condition | Possible cause |
|-------|----------------------|--|---|
| C1805 | VHCL HEIGHT ADJ DOWN | The vehicle height is 15 mm (0.59 in) or more raise than the reference height despite the output of exhaust solenoid ON signal continuously for 120 seconds by the air levelizer control module. | <ul style="list-style-type: none">• Harness or connector• Vehicle height sensor• Air compressor (exhaust solenoid)• Air tube• Rear suspension component parts |

DTC CONFIRMATION PROCEDURE

1. PRECONDITIONING

If "DTC CONFIRMATION PROCEDURE" has been previously conducted, always turn ignition switch OFF and wait at least 10 seconds before conducting the next test.

>> GO TO 2.

2. CHECK DTC DETECTION

④ With CONSULT-III

1. Start the engine and wait 150 seconds or more.
2. Perform "Self Diagnostic Result" in "E-SUS".

Is "C1805" detected ?

- YES >> Go to [SCS-80. "Diagnosis Procedure"](#).
NO >> INSPECTION END

Diagnosis Procedure

INFOID:000000006256075

1. CHECK APPEARANCE

Visually check for malfunction of suspension components, crush of air tube, installation malfunction, or deformation of vehicle height sensor.

Is the inspection result normal?

- YES >> GO TO 2.
NO >> Repaire or replace damaged parts.

2. CHECK INTERMITTENT INCIDENT

Refer to [GI-40. "Intermittent Incident"](#).

Is the inspection result normal?

- YES >> Perform "STANDARD VEHICLE HEIGHT SETTING". Refer to [SCS-67. "Work Procedure"](#).
NO >> Repair or replace damaged part.

C1806 VHCL HEIGHT SEN FIX

[AIR LEVELIZER CONTROL SYSTEM]

< DTC/CIRCUIT DIAGNOSIS >

C1806 VHCL HEIGHT SEN FIX

DTC Logic

INFOID:000000006256076

DTC DETECTION LOGIC

| DTC | Display item | Malfunction detected condition | Possible cause |
|-------|---------------------|--|--|
| C1806 | VHCL HEIGHT SEN FIX | The signal voltage of the vehicle height sensor does not change for cumulated time of 100 hours under the condition that the air levelizer control module outputs sensor voltage (4.5 – 5.5 V) with vehicle speeds 2 km/h (2 MPH) or more. | <ul style="list-style-type: none">• Harness or connector• Vehicle height sensor |

DTC CONFIRMATION PROCEDURE

1.PRECONDITIONING

If "DTC CONFIRMATION PROCEDURE" has been previously conducted, always turn ignition switch OFF and wait at least 10 seconds before conducting the next test.

>> GO TO 2.

2.CHECK VEHICLE HEIGHT SENSOR FIXATION

Ⓜ With CONSULT-III

1. Start the engine.
2. Select "VHCL HEIGHT SEN" in "Data Monitor" in "E-SUS".
3. Drive vehicle and maintain the following conditions for 5 minutes or more.

Vehicle speed : 5 km/h (3 MPH) or more

Does the value of "VHCL HEIGHT SEN" change?

YES >> INSPECTION END

NO >> Go to [SCS-81, "Diagnosis Procedure"](#).

Diagnosis Procedure

INFOID:000000006256077

1.CHECK APPEARANCE

Visually check for installation malfunction, or deformation of vehicle height sensor.

Is the inspection result normal?

YES >> GO TO 2.

NO >> Repaire or replace damaged parts.

2.CHECK VEHICLE HEIGHT SENSOR

Check the vehicle height sensor. Refer to [SCS-70, "Component Inspection"](#).

Is the inspection result normal?

YES >> Check intermittent incident. Refer to [GI-40, "Intermittent Incident"](#).

NO >> Replace the vehicle height sensor. Refer to [SCS-98, "Removal and Installation"](#).

C1807 VHCL HEIGHT SEN VOLT

< DTC/CIRCUIT DIAGNOSIS >

[AIR LEVELIZER CONTROL SYSTEM]

C1807 VHCL HEIGHT SEN VOLT

DTC Logic

INFOID:000000006256078

DTC DETECTION LOGIC

| DTC | Display item | Malfunction detected condition | Possible cause |
|-------|----------------------|---|---|
| C1807 | VHCL HEIGHT SEN VOLT | The sensor power supply is more than 5.5 V or less than 4.5 V continuously for 20 seconds when the ignition switch is ON. | <ul style="list-style-type: none"> • Harness or connector • Vehicle height sensor • Air levelizer control module |
| | | Sensor power supply is 0.5 V or more continuously for 1 second during 2 seconds after turning ON the ignition switch. | |

DTC CONFIRMATION PROCEDURE

1. PRECONDITIONING

If "DTC CONFIRMATION PROCEDURE" has been previously conducted, always turn ignition switch OFF and wait at least 10 seconds before conducting the next test.

>> GO TO 2.

2. CHECK DTC DETECTION

④ With CONSULT-III

1. Turn ignition switch ON and wait 20 seconds or more.
2. Perform "Self Diagnostic Results" in "E-SUS".

Is "C1807" detected ?

- YES >> Go to [SCS-82, "Diagnosis Procedure"](#).
 NO >> INSPECTION END

Diagnosis Procedure

INFOID:000000006256079

1. CHECK POWER SUPPLY CIRCUIT (PART 1)

1. Disconnect vehicle height sensor connector.
2. Turn ignition switch ON.
CAUTION:
Never start the engine.
3. Check voltage between the vehicle height sensor harness connector and ground.

| Vehicle height sensor | | — | Voltage |
|-----------------------|----------|--------|-------------|
| Connector | Terminal | | |
| C13 | 1 | Ground | 4.5 – 5.5 V |

Is the inspection result normal?

- YES >> GO TO 3.
 NO >> GO TO 2.

2. CHECK POWER SUPPLY CIRCUIT (PART 2)

1. Turn ignition switch OFF.
2. Disconnect air levelizer control module connector.
3. Check continuity between air levelizer control module harness connector and vehicle height sensor harness connector.

| Air levelizer control module | | Vehicle height sensor | | Continuity |
|------------------------------|----------|-----------------------|----------|------------|
| Connector | Terminal | Connector | Terminal | |
| B84 | 13 | C13 | 1 | Existed |

C1807 VHCL HEIGHT SEN VOLT

< DTC/CIRCUIT DIAGNOSIS >

[AIR LEVELIZER CONTROL SYSTEM]

4. Check continuity between air levelizer control module harness connector and ground.

| Air levelizer control module | | — | Continuity |
|------------------------------|----------|--------|-------------|
| Connector | Terminal | | |
| B84 | 13 | Ground | Not existed |

Is the inspection result normal?

YES >> 1. Check intermittent incident. Refer to [GI-40, "Intermittent Incident"](#).
2. If inspection result is OK, replace the air levelizer control module. Refer to [SCS-94, "Removal and Installation"](#).

NO >> Repair or replace damaged parts.

3. CHECK HARNESS BETWEEN AIR LEVELIZER CONTROL MODULE AND VEHICLE HEIGHT SENSOR

1. Turn ignition switch OFF.
2. Disconnect air levelizer control module connector.
3. Check continuity between air levelizer control module harness connector and vehicle height sensor harness connector.

| Air levelizer control module | | Vehicle height sensor | | Continuity |
|------------------------------|----------|-----------------------|----------|------------|
| Connector | Terminal | Connector | Terminal | |
| B84 | 5 | C13 | 2 | Existed |
| | 4 | | 3 | |

4. Check continuity between air levelizer control module harness connector and ground.

| Air levelizer control module | | — | Continuity |
|------------------------------|----------|--------|-------------|
| Connector | Terminal | | |
| B84 | 5 | Ground | Not existed |
| | 4 | | |

Are the inspection results normal?

YES >> GO TO 4.

NO >> Repair or replace damaged parts.

4. CHECK VEHICLE HEIGHT SENSOR

Check the vehicle height sensor. Refer to [SCS-70, "Component Inspection"](#).

Is the inspection result normal?

YES >> Check intermittent incident. Refer to [GI-40, "Intermittent Incident"](#).

NO >> Replace the vehicle height sensor. Refer to [SCS-98, "Removal and Installation"](#).

C1808 AIR SUS COMPRS FNCTN

< DTC/CIRCUIT DIAGNOSIS >

[AIR LEVELIZER CONTROL SYSTEM]

C1808 AIR SUS COMPRS FNCTN

DTC Logic

INFOID:000000006256080

DTC DETECTION LOGIC

| DTC | Display item | Malfunction detected condition | Possible cause |
|-------|----------------------|---|---|
| C1808 | AIR SUS COMPRS FNCTN | <p>The cumulative operating time of the air compressor reaches 180 seconds or more.</p> <p>NOTE: Cumulative time is cleared under the following conditions:</p> <ul style="list-style-type: none">• Ignition switch: OFF• Exhaust conditions: satisfied [Vehicle height remains 15 mm (0.59 in) or more higher than the reference height for 30 seconds.] | <ul style="list-style-type: none">• Harness or connector• Vehicle height sensor• Air compressor (exhaust solenoid)• Air compressor relay• Overloaded• Rear shock absorber (air chamber)• Rear suspension component parts• Air tube |

DTC CONFIRMATION PROCEDURE

1. PRECONDITIONING

If "DTC CONFIRMATION PROCEDURE" has been previously conducted, always turn ignition switch OFF and wait at least 10 seconds before conducting the next test.

>> GO TO 2.

2. CHECK DTC DETECTION

Ⓟ With CONSULT-III

1. Set vehicle in the unloaded vehicle status.
2. Start the engine and wait 5 minutes or more.
3. Perform "Self Diagnostic Result" in "E-SUS".

Is "C1808" detected ?

- YES >> Go to [SCS-84. "Diagnosis Procedure"](#).
NO >> INSPECTION END

Diagnosis Procedure

INFOID:000000006256081

1. CHECK APPEARANCE

Visually check for malfunction of suspension components, damage of air chamber of rear shock absorber, installation malfunction, or deformation of vehicle height sensor.

Is the inspection result normal?

- YES >> GO TO 2.
NO >> Repair or replace damaged parts.

2. CHECK AIR LEAK

Apply soapy water to air tube, connecting portions between air tube and each component, and air chamber of rear shock absorber. Check for air leakage.

Is the inspection result normal?

- YES >> GO TO 3.
NO >> Repair or replace damaged parts.

3. CHECK AIR COMPRESSOR RELAY POWER SUPPLY

1. Turn ignition switch OFF.
2. Check 30A fuse (#1).
3. Disconnect air compressor relay connector.
4. Check voltage between air compressor relay harness connector and ground.

C1808 AIR SUS COMPRS FNCTN

< DTC/CIRCUIT DIAGNOSIS >

[AIR LEVELIZER CONTROL SYSTEM]

| Air compressor relay | | — | Voltage |
|----------------------|----------|--------|-----------------|
| Connector | Terminal | | |
| E116 | 5 | Ground | Battery voltage |

Is the inspection result normal?

YES >> GO TO 4.

NO >> Repair or replace damaged part.

4.CHECK AIR COMPRESSOR RELAY OUTPUT CIRCUIT

1. Turn ignition switch OFF.
2. Disconnect air compressor connector.
3. Check continuity between air compressor relay harness connector and air compressor harness connector.

| Air compressor relay | | Air compressor | | Continuity |
|----------------------|----------|----------------|----------|------------|
| Connector | Terminal | Connector | Terminal | |
| E116 | 3 | C12 | 1 | Existed |

4. Check continuity between air compressor relay harness connector and ground.

| Air compressor relay | | — | Continuity |
|----------------------|----------|--------|-------------|
| Connector | Terminal | | |
| E116 | 3 | Ground | Not existed |

Are the inspection results normal?

YES >> GO TO 5.

NO >> Repair or replace damaged part.

5.CHECK AIR COMPRESSOR GROUND

Check continuity between air compressor harness connector and ground.

| Air compressor | | — | Continuity |
|----------------|----------|--------|------------|
| Connector | Terminal | | |
| C12 | 2 | Ground | Existed |

Are the inspection results normal?

YES >> GO TO 6.

NO >> Repair or replace damaged part.

6.CHECK AIR COMPRESSOR RELAY

Check the air compressor relay. Refer to [SCS-79, "Component Inspection \(Air Compressor Relay\)"](#).

Is the inspection result normal?

YES >> GO TO 7.

NO >> Replace the air compressor relay.

7.CHECK AIR COMPRESSOR

Check the air compressor. Refer to [SCS-79, "Component Inspection \(Air Compressor\)"](#).

Is the inspection result normal?

YES >> GO TO 8.

NO >> Replace the air compressor. Refer to [SCS-95, "Removal and Installation"](#).

8.CHECK INTERMITTENT INCIDENT

Refer to [GI-40, "Intermittent Incident"](#).

Is the inspection result normal?

- YES >>
1. Perform "STANDARD VEHICLE HEIGHT SETTING". Refer to [SCS-67, "Work Procedure"](#).
 2. If DTC is detected, replace the air levelizer control module. Refer to [SCS-94, "Removal and Installation"](#).

C1808 AIR SUS COMPRS FNCTN

< DTC/CIRCUIT DIAGNOSIS >

[AIR LEVELIZER CONTROL SYSTEM]

NO >> Repair or replace damaged part.

U1000 CAN COMM CIRCUIT

[AIR LEVELIZER CONTROL SYSTEM]

< DTC/CIRCUIT DIAGNOSIS >

U1000 CAN COMM CIRCUIT

Description

INFOID:000000006256082

CAN (Controller Area Network) is a serial communication line for real-time application. It is an on-vehicle multiplex communication line with high data communication speed and excellent malfunction detection ability. Many electronic control units are equipped onto a vehicle, and each control unit shares information and links with other control units during operation (not independently). In CAN communication, control units are connected with 2 communication lines (CAN-H line, CAN-L line) allowing a high rate of information transmission with less wiring. Each control unit transmits/receives data but selectively reads required data only.

DTC Logic

INFOID:000000006256083

DTC DETECTION LOGIC

| DTC | Display item | Malfunction detected condition | Possible cause |
|-------|------------------|---|---|
| U1000 | CAN COMM CIRCUIT | Air levelizer control module is not transmitting or receiving CAN communication signal for 2 seconds or more. | <ul style="list-style-type: none">• Harness or connectors (CAN communication line is open or shorted.)• Air levelizer control module |

DTC CONFIRMATION PROCEDURE

1. PRECONDITIONING

If "DTC CONFIRMATION PROCEDURE" is previously conducted, always turn ignition switch OFF and wait at least 10 seconds before performing the next test.

>> GO TO 2.

2. CHECK DTC DETECTION

Ⓜ With CONSULT-III

1. Start the engine.
2. Run engine for at least 2 consecutive seconds at idle speed.
3. Perform "Self Diagnostic Results" in "E-SUS".

Is "U1000" detected?

YES >> Go to [SCS-87, "Diagnosis Procedure"](#).

NO >> INSPECTION END

Diagnosis Procedure

INFOID:000000006256084

Go to [LAN-18, "Trouble Diagnosis Flow Chart"](#).

U1010 CONTROL UNIT (CAN)

[AIR LEVELIZER CONTROL SYSTEM]

< DTC/CIRCUIT DIAGNOSIS >

U1010 CONTROL UNIT (CAN)

Description

INFOID:000000006256085

CAN (Controller Area Network) is a serial communication line for real-time application. It is an on-vehicle multiplex communication line with high data communication speed and excellent malfunction detection ability. Many electronic control units are equipped onto a vehicle, and each control unit shares information and links with other control units during operation (not independently). In CAN communication, control units are connected with 2 communication lines (CAN-H line, CAN-L line) allowing a high rate of information transmission with less wiring. Each control unit transmits/receives data but selectively reads required data only.

DTC Logic

INFOID:000000006256086

DTC DETECTION LOGIC

| DTC | Display item1 | Malfunction detected condition | Possible cause |
|-------|--------------------|---|------------------------------|
| U1010 | CONTROL UNIT (CAN) | Detecting error during the initial diagnosis of CAN controller of air levelizer control module. | Air levelizer control module |

DTC CONFIRMATION PROCEDURE

1. PRECONDITIONING

If "DTC CONFIRMATION PROCEDURE" is previously conducted, always turn ignition switch OFF and wait at least 10 seconds before performing the next test.

>> GO TO 2.

2. CHECK DTC DETECTION

④ With CONSULT-III

1. Start the engine.
2. Run engine for at least 2 consecutive seconds at idle speed.
3. Perform "Self Diagnostic Results" in "E-SUS".

Is "U1010" detected?

YES >> Go to [SCS-88, "Diagnosis Procedure"](#).

NO >> INSPECTION END

Diagnosis Procedure

INFOID:000000006256087

1. CHECK INTERMITTENT INCIDENT

Refer to [GI-40, "Intermittent Incident"](#).

Is the inspection result normal?

YES >> Replace the air levelizer control module. Refer to [SCS-94, "Removal and Installation"](#).

NO >> Repair or replace damaged parts.

POWER SUPPLY AND GROUND CIRCUIT

< DTC/CIRCUIT DIAGNOSIS >

[AIR LEVELIZER CONTROL SYSTEM]

POWER SUPPLY AND GROUND CIRCUIT

Diagnosis Procedure

INFOID:000000006256088

1. CHECK AIR LEVELIZER CONTROL MODULE IGNITION POWER SUPPLY CIRCUIT

1. Disconnect air levelizer control module connector.
2. Turn ignition switch ON.
CAUTION:
Never start the engine.
3. Check voltage between the air levelizer control module harness connector and ground.

| Air levelizer control module | | — | Voltage |
|------------------------------|----------|--------|-----------|
| Connector | Terminal | | |
| B84 | 9 | Ground | 10 – 16 V |

Is the inspection result normal?

- YES >> INSPECTION END
NO >> GO TO 2.

2. CHECK HARNESS BETWEEN AIR LEVELIZER CONTROL MODULE AND IPDM E/R

1. Turn ignition switch OFF.
2. Disconnect IPDM E/R connector.
3. Check continuity between air levelizer control module harness connector and IPDM E/R harness connector.

| Air levelizer control module | | IPDM E/R | | Continuity |
|------------------------------|----------|-----------|----------|------------|
| Connector | Terminal | Connector | Terminal | |
| B84 | 9 | E10 | 5 | Existed |

4. Check continuity between air levelizer control module harness connector ground.

| Air levelizer control module | | — | Continuity |
|------------------------------|----------|--------|-------------|
| Connector | Terminal | | |
| B84 | 9 | Ground | Not existed |

Is the inspection result normal?

- YES >> GO TO 3.
NO >> Repair or replace damaged parts.

3. CHECK IPDM E/R

Check the IPDM E/R. Refer to [PCS-10, "Diagnosis Description"](#).

Is the inspection result normal?

- YES >> Check intermittent incident. Refer to [GI-40, "Intermittent Incident"](#).
NO >> Repair or replace damaged parts.

A
B
C
D
SCS
F
G
H
I
J
K
L
M
N
O
P

CK SUSP INDICATOR LAMP CIRCUIT

< DTC/CIRCUIT DIAGNOSIS >

[AIR LEVELIZER CONTROL SYSTEM]

CK SUSP INDICATOR LAMP CIRCUIT

Description

INFOID:000000006256089

Air levelizer control module transmits CK SUSP indicator lamp signal to combination meter via CAN communication, when setting of standard vehicle height is incomplete. Based on the signal, combination meter turns CK SUSP indicator lamp ON.

Component Function Check

INFOID:000000006256090

1. CHECK CK SUSP INDICATOR LAMP OPERATION

Ⓟ CONSULT-III

1. Turn ignition switch ON.
2. Select "WARNING LAMP" in "Active Test" in "E-SUS".
3. While operating test item, check that the CK SUSP indicator lamp activates.

ON : CK SUSP indicator lamp turns ON

OFF : CK SUSP indicator lamp turns OFF

Is the inspection result normal?

YES >> INSPECTION END

NO >> Refer to [SCS-90, "Diagnosis Procedure"](#).

Diagnosis Procedure

INFOID:000000006256091

1. PERFORM SELF-DIAGNOSIS

Ⓟ CONSULT-III

1. Turn ignition switch ON.
2. Select "Self Diagnostic Result" in "E-SUS".

Are any DTC detected?

YES >> Refer to [SCS-59, "DTC Index"](#).

NO >> GO TO 2.

2. CHECK COMBINATION METER

Check combination meter. Refer to [MWI-29, "On Board Diagnosis Function"](#).

Is the inspection result normal?

YES >> Replace the air levelizer control module. Refer to [SCS-94, "Removal and Installation"](#).

NO >> Repair or replace the combination meter. Refer to [MWI-85, "Removal and Installation"](#).

VEHICLE HEIGHT CANNOT BE RAISED

< SYMPTOM DIAGNOSIS >

[AIR LEVELIZER CONTROL SYSTEM]

SYMPTOM DIAGNOSIS

VEHICLE HEIGHT CANNOT BE RAISED

Description

INFOID:000000006256092

Vehicle height remains in low status.

Diagnosis Procedure

INFOID:000000006256093

1. CHECK APPEARANCE

Visually check for fuse, malfunction of suspension components, installation malfunction, or deformation of vehicle height sensor.

Is the inspection result normal?

YES >> GO TO 2.

NO >> Repaire or replace damaged parts.

2. PERFORM SELF-DIAGNOSIS

1. Turn ignition switch ON.
2. Select "Self Diagnostic Result" in "E-SUS".

Are any DTC detected?

YES >> Refer to [SCS-59, "DTC Index"](#).

NO >> GO TO 3.

3. PERFORM STANDARD VEHICLE HEIGHT SETTING

Refer to [SCS-67, "Work Procedure"](#).

Is the symptom improved?

YES >> INSPECTION END

NO >> Replace the air levelizer control module. Refer to [SCS-94, "Removal and Installation"](#).

A
B
C
D
E
F
G
H
I
J
K
L
M
N
O
P

SCS

VEHICLE HEIGHT CANNOT BE LOWERED

< SYMPTOM DIAGNOSIS >

[AIR LEVELIZER CONTROL SYSTEM]

VEHICLE HEIGHT CANNOT BE LOWERED

Description

INFOID:000000006256094

Vehicle height remains in high status.

Diagnosis Procedure

INFOID:000000006256095

1. CHECK APPEARANCE

Visually check for fuse, malfunction of suspension components, installation malfunction, or deformation of vehicle height sensor.

Is the inspection result normal?

YES >> GO TO 2.

NO >> Repair or replace damaged parts.

2. PERFORM SELF-DIAGNOSIS

-
1. Turn ignition switch ON.
 2. Select "Self Diagnostic Result" in "E-SUS".

Are any DTC detected?

YES >> Refer to [SCS-59, "DTC Index"](#).

NO >> GO TO 3.

3. PERFORM STANDARD VEHICLE HEIGHT SETTING

Refer to [SCS-67, "Work Procedure"](#).

Is the symptom improved?

YES >> INSPECTION END

NO >> Replace the air levelizer control module. Refer to [SCS-94, "Removal and Installation"](#).

CK SUSP INDICATOR LAMP DOES NOT TURN OFF

< SYMPTOM DIAGNOSIS >

[AIR LEVELIZER CONTROL SYSTEM]

CK SUSP INDICATOR LAMP DOES NOT TURN OFF

Description

INFOID:000000006256096

- CK SUSP indicator lamp turns ON while driving the vehicle.
- CK SUSP indicator lamp does not turn ON after the completion of standard vehicle height setting.

Diagnosis Procedure

INFOID:000000006256097

1. STANDARD VEHICLE HEIGHT SETTING

Perform "STANDARD VEHICLE HEIGHT SETTING". Refer to [SCS-67. "Work Procedure"](#).

Does CK SUSP indicator lamp turn OFF?

YES >> INSPECTION END

NO >> Replace the air levelizer control module. Refer to [SCS-94. "Removal and Installation"](#).

A

B

C

D

SCS

F

G

H

I

J

K

L

M

N

O

P

AIR LEVELIZER CONTROL MODULE

< REMOVAL AND INSTALLATION >

[AIR LEVELIZER CONTROL SYSTEM]

REMOVAL AND INSTALLATION

AIR LEVELIZER CONTROL MODULE

Exploded View

INFOID:000000006256098

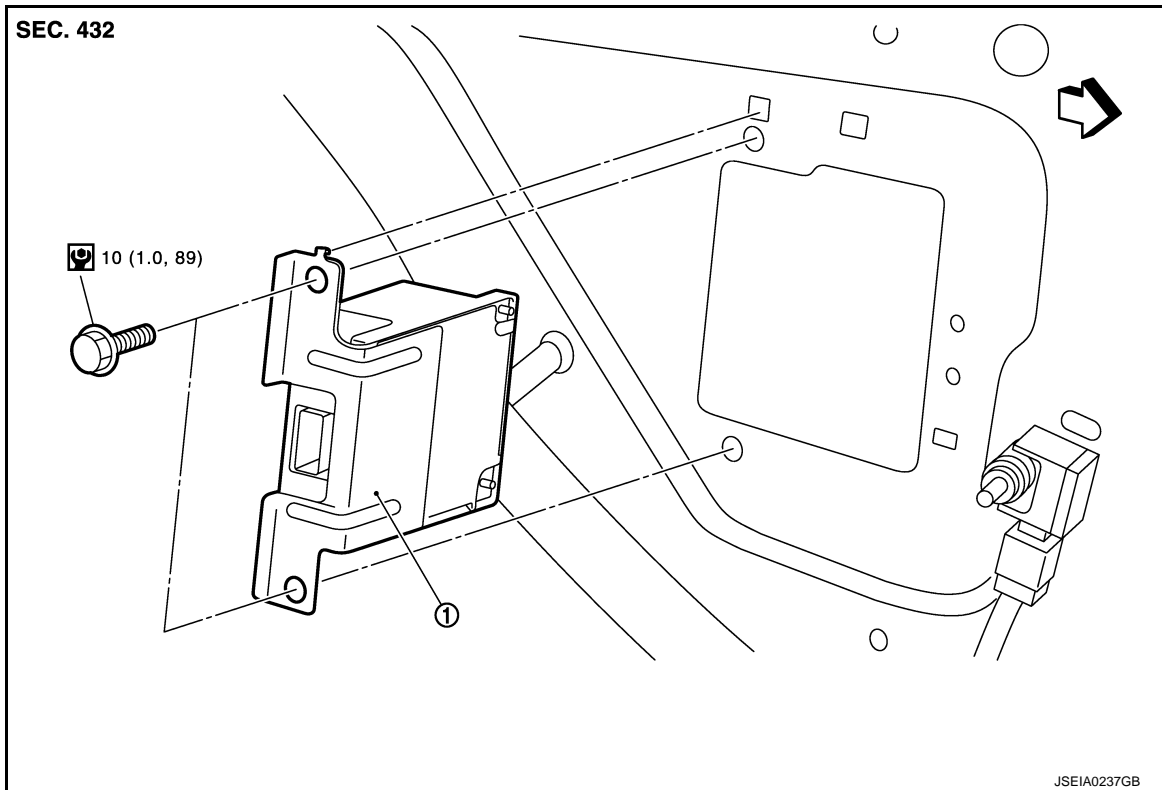

1. Air levelizer control module

←: Vehicle front

Refer to [GI-4, "Components"](#) for symbols not described on the above.

Removal and Installation

INFOID:000000006256099

REMOVAL

CAUTION:

Never impact on air levelizer control module when removing or installing air levelizer control module.

1. Disconnect battery cable from negative terminal.
2. Remove luggage side lower finisher (LH). Refer to [INT-33, "Exploded View"](#).
3. Disconnect air levelizer control module harness connector.
4. Remove the air levelizer control module.

INSTALLATION

Install in the reverse order of removal.

Adjustment

INFOID:000000006256100

After air levelizer control module is replaced, perform "STANDARD VEHICLE HEIGHT SETTING". Refer to [SCS-67, "Work Procedure"](#).

AIR COMPRESSOR/AIR TUBE

< REMOVAL AND INSTALLATION >

[AIR LEVELIZER CONTROL SYSTEM]

AIR COMPRESSOR/AIR TUBE

Exploded View

INFOID:000000006256101

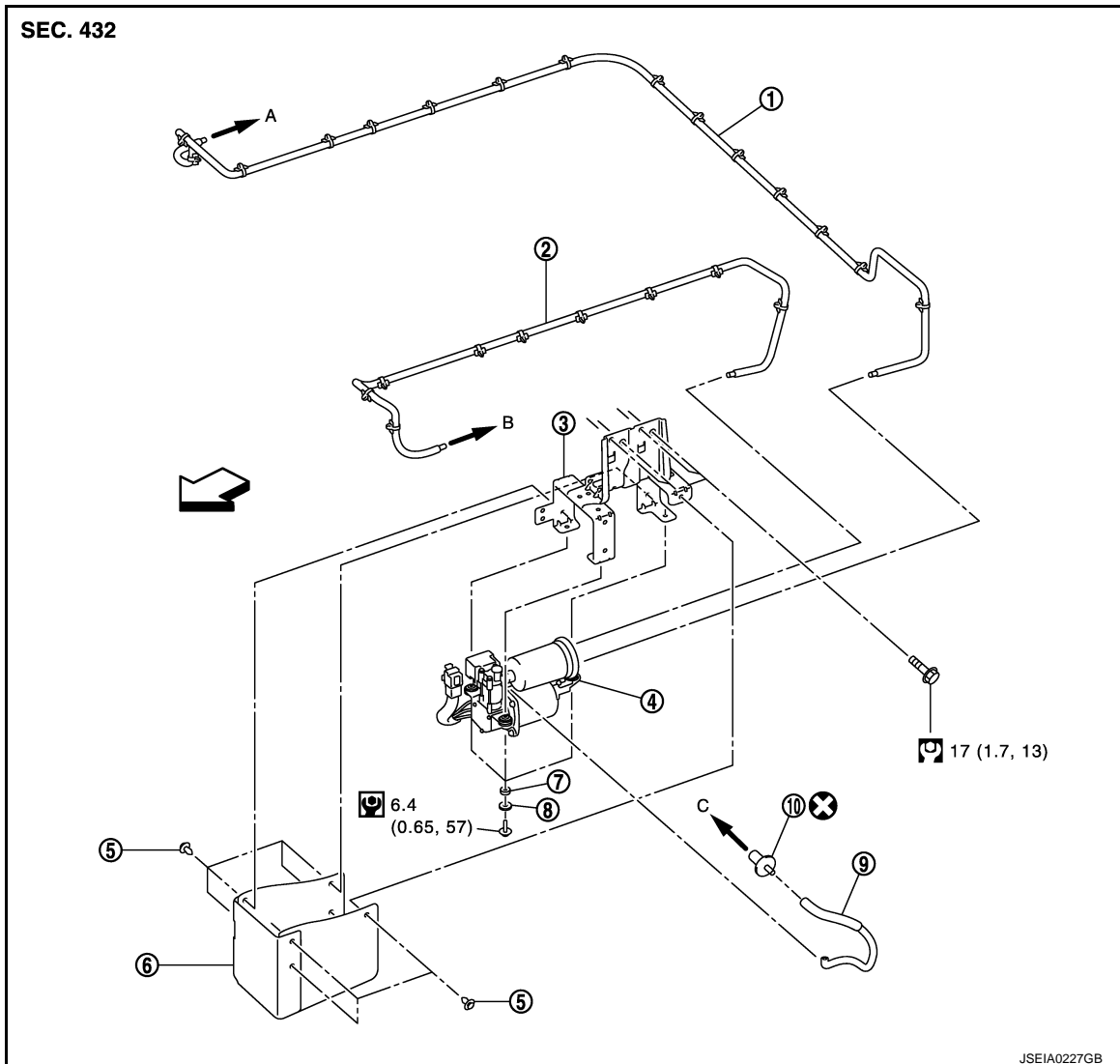

- | | | |
|--------------------------------|--------------------------------|-----------------|
| 1. Air tube A | 2. Air tube B | 3. Bracket |
| 4. Air compressor | 5. Clip | 6. Cover |
| 7. Insulator | 8. Washer | 9. Exhaust tube |
| 10. Exhaust tube connector | | |
| A. To rear shock absorber (RH) | B. To rear shock absorber (LH) | C. To frame |

← Vehicle front

Refer to [GI-4, "Components"](#) for symbols not described on the above.

Removal and Installation

INFOID:000000006256102

REMOVAL

CAUTION:

Seal the removed part using vinyl tape for preventing dirt from getting on or entering the removed part.

1. Lift up the vehicle.
2. Remove the cover.
3. Disconnect the air compressor harness connector.

AIR COMPRESSOR/AIR TUBE

< REMOVAL AND INSTALLATION >

[AIR LEVELIZER CONTROL SYSTEM]

4. Using a small spanner, remove the air tube A (1) and B (2) from air compressor.

CAUTION:

Be careful since air flows swiftly from air tube.

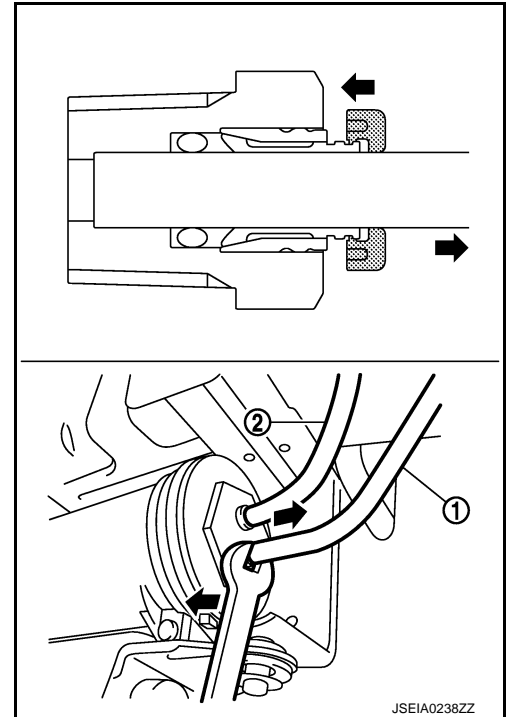

5. Remove the exhaust tube (1) from exhaust tube connector (2).
6. Remove the exhaust tube connector only when it is damaged.
7. Remove the exhaust tube from air compressor.
8. Remove the air compressor from bracket.
9. Remove the bracket from vehicle.
10. Remove the air tube A and B from rear shock absorbers RH and LH, according to the procedure in step 4.
11. Remove the air tube A and B from vehicle.
12. Perform inspection after removal. Refer to [SCS-97, "Inspection"](#).

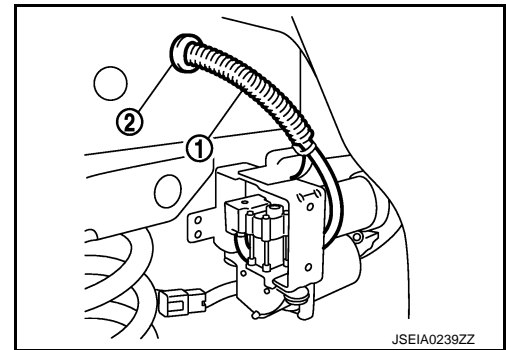

INSTALLATION

Note the following, and install in the reverse order of the removal.

- When installing air tube (1) to air compressor or shock absorber, insert as shown in the figure.
- Dry each component thoroughly before installing, to prevent moisture from entering air compressor.

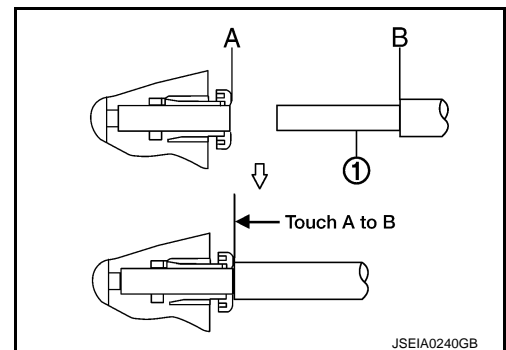

AIR COMPRESSOR/AIR TUBE

< REMOVAL AND INSTALLATION >

[AIR LEVELIZER CONTROL SYSTEM]

- Completely engage hooks on frame when installing bracket.

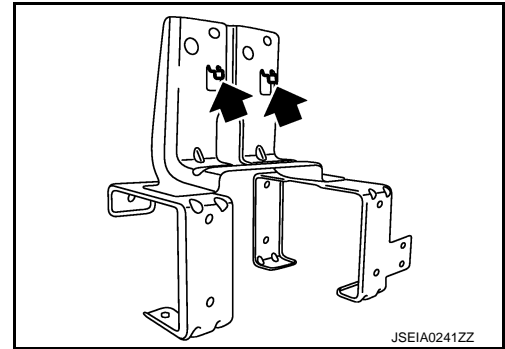

- Install exhaust tube (1) according to the figure.
- Perform inspection after installation. Rfer to [SCS-97, "Inspection"](#).

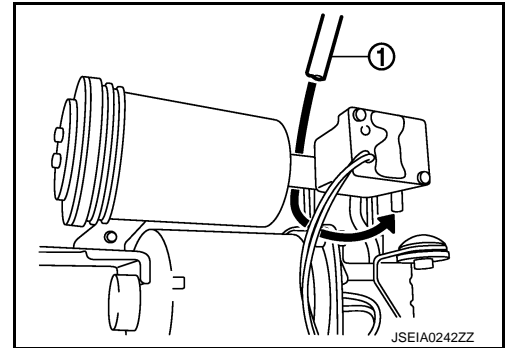

Inspection

INSPECTION AFTER REMOVAL

Check area 8 mm (0.31 in) from front end of air tubes for damage and burrs.

INSPECTION AFTER INSTALLATION

- Lightly pull air tubes and check that it is locked.
- Apply some soapy water to each joint. Check that there is no leakage of air after the activation of the air compressor during "Active Test" of CONSULT-III.

CAUTION:

Never allow soapy water to enter the inside of air compressor.

INFOID:000000006256103

VEHICLE HEIGHT SENSOR

< REMOVAL AND INSTALLATION >

[AIR LEVELIZER CONTROL SYSTEM]

VEHICLE HEIGHT SENSOR

Exploded View

INFOID:000000006256104

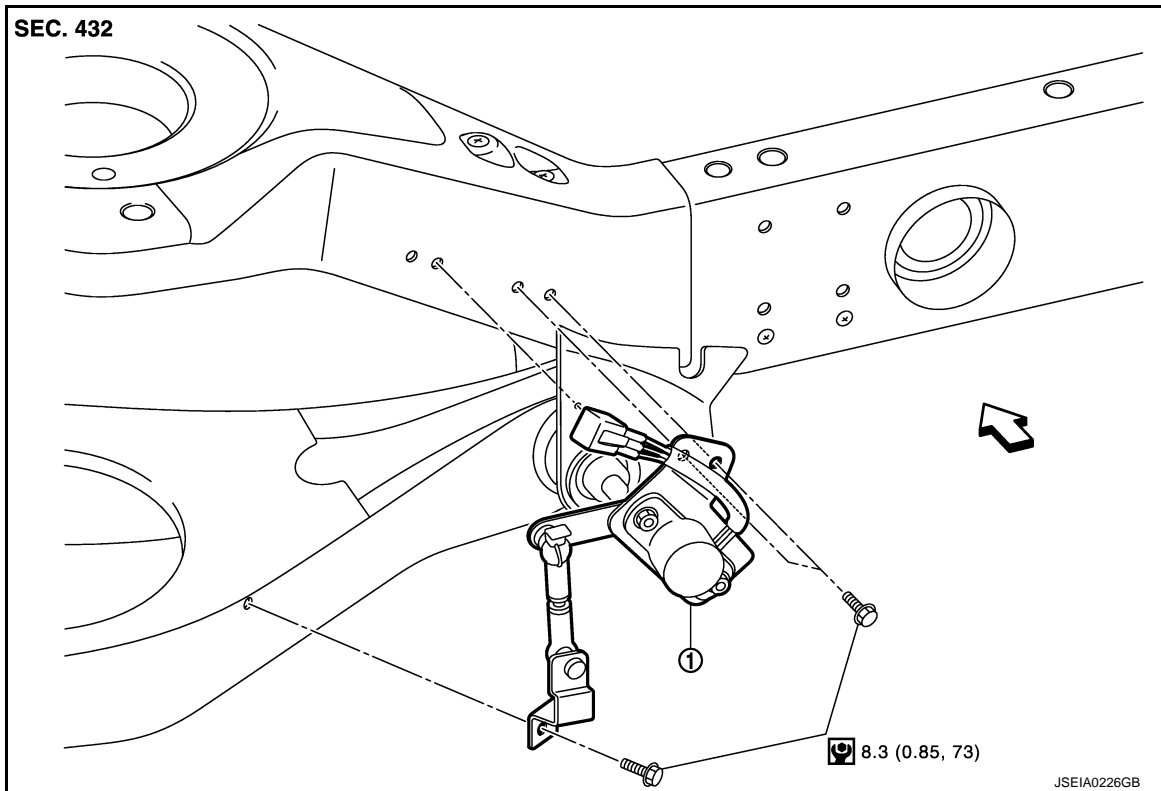

1. Vehicle height sensor

← Vehicle front

Refer to [GI-4. "Components"](#) for symbols not described on the above.

Removal and Installation

INFOID:000000006256105

REMOVAL

CAUTION:

Never disassemble the vehicle height sensor.

1. Lift up the vehicle.
2. Disconnect the vehicle height sensor harness connector.
3. Remove the vehicle height sensor.

INSTALLATION

Note the following, and install in the reverse order of the removal. Completely engage hooks on frame when installing vehicle height sensor.

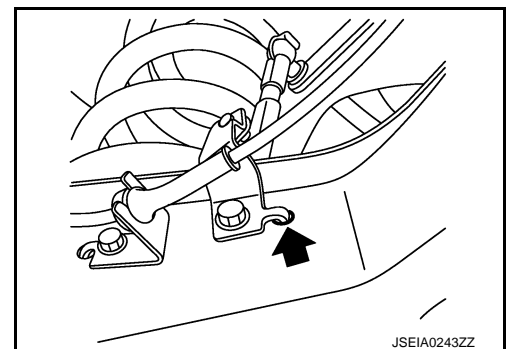

VEHICLE HEIGHT SENSOR

< REMOVAL AND INSTALLATION >

[AIR LEVELIZER CONTROL SYSTEM]

Adjustment

INFOID:000000006256106

After vehicle height sensor is replaced, removal or installation, perform "STANDARD VEHICLE HEIGHT SETTING". Refer to [SCS-67. "Work Procedure"](#).

- A
- B
- C
- D
- E
- F
- G
- H
- I
- J
- K
- L
- M
- N
- O
- P

SCS