

SECTION **SR**

SRS AIRBAG

A
B
C
D
E
F
G
SR
I
J
K
L
M
N
O
P

CONTENTS

PRECAUTION	2	SPIRAL CABLE	14
PRECAUTIONS	2	Exploded View	14
Precaution for Supplemental Restraint System (SRS) "AIR BAG" and "SEAT BELT PRE-TENSIONER"	2	Removal and Installation	14
Precaution Necessary for Steering Wheel Rotation after Battery Disconnect	2	FRONT PASSENGER AIR BAG MODULE	17
Precaution for Battery Service	3	Exploded View	17
Occupant Classification System	3	Removal and Installation	17
Service	3	SIDE CURTAIN AIR BAG MODULE	19
PREPARATION	4	Exploded View	19
PREPARATION	4	Removal and Installation	19
Commercial Service Tools	4	CRASH ZONE SENSOR	22
BASIC INSPECTION	5	Exploded View	22
COLLISION DIAGNOSIS	5	Removal and Installation	22
FOR FRONTAL COLLISION	5	SIDE AIR BAG (SATELLITE) SENSOR	24
FOR FRONTAL COLLISION : When SRS is activated in a collision	5	Exploded View	24
FOR FRONTAL COLLISION : When SRS is not activated in a collision	6	Removal and Installation	24
FOR SIDE AND ROLLOVER COLLISION	7	DIAGNOSIS SENSOR UNIT	26
FOR SIDE AND ROLLOVER COLLISION : When SRS is activated in a collision	7	Exploded View	26
FOR SIDE AND ROLLOVER COLLISION : When SRS is not activated in a collision	8	Removal and Installation	26
REMOVAL AND INSTALLATION	11	SEAT BELT PRE-TENSIONER	28
DRIVER AIR BAG MODULE	11	Exploded View	28
Exploded View	11	Removal and Installation	28
Removal and Installation	11	LAP PRE-TENSIONER	29
		Exploded View	29
		Removal and Installation	29
		OCCUPANT DETECTION SYSTEM CONTROL UNIT	30
		Exploded View	30
		Removal and Installation	30

PRECAUTIONS

< PRECAUTION >

PRECAUTION

PRECAUTIONS

Precaution for Supplemental Restraint System (SRS) "AIR BAG" and "SEAT BELT PRE-TENSIONER"

INFOID:000000006113043

The Supplemental Restraint System such as "AIR BAG" and "SEAT BELT PRE-TENSIONER", used along with a front seat belt, helps to reduce the risk or severity of injury to the driver and front passenger for certain types of collision. This system includes seat belt switch inputs and dual stage front air bag modules. The SRS system uses the seat belt switches to determine the front air bag deployment, and may only deploy one front air bag, depending on the severity of a collision and whether the front occupants are belted or unbelted. Information necessary to service the system safely is included in the "SRS AIR BAG" and "SEAT BELT" of this Service Manual.

WARNING:

- To avoid rendering the SRS inoperative, which could increase the risk of personal injury or death in the event of a collision that would result in air bag inflation, all maintenance must be performed by an authorized NISSAN/INFINITI dealer.
- Improper maintenance, including incorrect removal and installation of the SRS, can lead to personal injury caused by unintentional activation of the system. For removal of Spiral Cable and Air Bag Module, see the "SRS AIR BAG".
- Do not use electrical test equipment on any circuit related to the SRS unless instructed to in this Service Manual. SRS wiring harnesses can be identified by yellow and/or orange harnesses or harness connectors.

PRECAUTIONS WHEN USING POWER TOOLS (AIR OR ELECTRIC) AND HAMMERS

WARNING:

- When working near the Air Bag Diagnosis Sensor Unit or other Air Bag System sensors with the ignition ON or engine running, DO NOT use air or electric power tools or strike near the sensor(s) with a hammer. Heavy vibration could activate the sensor(s) and deploy the air bag(s), possibly causing serious injury.
- When using air or electric power tools or hammers, always switch the ignition OFF, disconnect the battery, and wait at least 3 minutes before performing any service.

Precaution Necessary for Steering Wheel Rotation after Battery Disconnect

INFOID:000000006113044

NOTE:

- Before removing and installing any control units, first turn the push-button ignition switch to the LOCK position, then disconnect both battery cables.
- After finishing work, confirm that all control unit connectors are connected properly, then re-connect both battery cables.
- Always use CONSULT-III to perform self-diagnosis as a part of each function inspection after finishing work. If a DTC is detected, perform trouble diagnosis according to self-diagnosis results.

For vehicle with steering lock unit, if the battery is disconnected or discharged, the steering wheel will lock and cannot be turned.

If turning the steering wheel is required with the battery disconnected or discharged, follow the operation procedure below before starting the repair operation.

OPERATION PROCEDURE

1. Connect both battery cables.

NOTE:

Supply power using jumper cables if battery is discharged.

2. Turn the push-button ignition switch to ACC position.
(At this time, the steering lock will be released.)
3. Disconnect both battery cables. The steering lock will remain released with both battery cables disconnected and the steering wheel can be turned.
4. Perform the necessary repair operation.

PRECAUTIONS

< PRECAUTION >

- When the repair work is completed, re-connect both battery cables. With the brake pedal released, turn the push-button ignition switch from ACC position to ON position, then to LOCK position. (The steering wheel will lock when the push-button ignition switch is turned to LOCK position.)
- Perform self-diagnosis check of all control units using CONSULT-III.

Precaution for Battery Service

INFOID:000000006113045

Before disconnecting the battery, lower both the driver and passenger windows. This will prevent any interference between the window edge and the vehicle when the door is opened/closed. During normal operation, the window slightly raises and lowers automatically to prevent any window to vehicle interference. The automatic window function will not work with the battery disconnected.

Occupant Classification System

INFOID:000000006113047

- Replace occupant classification system control unit and passenger front seat cushion as an assembly. Refer to [SE-105, "Exploded View"](#).

Service

INFOID:000000006113046

- Never use electrical test equipment to check SRS circuits unless instructed to in this Service Manual.
- Before servicing the SRS, turn ignition switch OFF, disconnect battery negative terminal and wait at least 3 minutes.
For approximately 3 minutes after the battery negative terminal is removed, it is still possible for the air bag and seat belt pre-tensioner to deploy. Therefore, never work on any SRS connectors or wires until at least 3 minutes have elapsed.
- Diagnosis sensor unit must always be installed with their arrow marks "⇐" pointing towards the front of the vehicle for proper operation. Also check diagnosis sensor unit for cracks, deformities, or rust before installation and replace as required.
- The spiral cable must be aligned in the neutral position since its rotations are limited. Never turn steering wheel and column after removal of steering gear.
- Handle air bag module carefully. Always place driver and front passenger air bag modules with the pad side facing upward and seat mounted front side air bag module standing with the stud bolt side facing downward.
- Perform self-diagnosis to check entire SRS for proper function after replacing any components.
- After air bag deploys, the front instrument panel assembly should be replaced if damaged.
- Always replace instrument panel pad following front passenger air bag deployment.

A
B
C
D
E
F
G
SR
I
J
K
L
M
N
O
P

PREPARATION

< PREPARATION >

PREPARATION

PREPARATION

Commercial Service Tools

INFOID:000000006113048

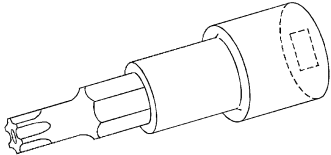
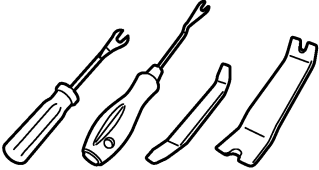
Tool name	Description
<p data-bbox="181 514 451 546">Tamper resistant TORX bit</p>  <p data-bbox="820 630 876 646">S-NT757</p>	<p data-bbox="987 504 1437 562">Removes driver air bag module and/or Air bag diagnosis sensor unit</p>
<p data-bbox="181 766 321 798">Remover tool</p>  <p data-bbox="820 882 909 898">JMKIA3050ZZ</p>	<p data-bbox="987 766 1372 798">Removes clips, pawls, and metal clips</p>

COLLISION DIAGNOSIS

< BASIC INSPECTION >

BASIC INSPECTION

COLLISION DIAGNOSIS FOR FRONTAL COLLISION

FOR FRONTAL COLLISION : When SRS is activated in a collision

INFOID:000000006113080

CAUTION:

Due to varying models and option levels, not all parts listed in the chart below apply to all vehicles.

WORK PROCEDURE

1. Before performing any of the following steps, ensure that all vehicle body and structural repairs have been completed.
2. Replace the diagnosis sensor unit.
3. Remove the front air bag modules, crash zone sensor, bracket and seat belt pre-tensioner assemblies.
4. Check the SRS components using the table below:
Replace any SRS components showing visible signs of damage. (dents, cracks and deformation, etc.)
5. Install new front air bag modules, crash zone sensor assembly, bracket and seat belt pre-tensioner assemblies.
6. Perform self-diagnosis using CONSULT-III or air bag warning lamp. Refer to [SRC-14, "Description"](#) for details. Ensure entire SRS operates properly.
7. After the work is completed, perform self-diagnosis to check that no malfunction is detected. Refer to [SRC-14, "Description"](#).

SRS INSPECTION (FOR FRONTAL COLLISION)

Part	Inspection
Driver air bag module	If the driver air bag has deployed: REPLACE Install with new fasteners.
Front passenger air bag module (if equipped)	If the front passenger air bag has deployed: REPLACE Install with new fasteners.
Crash zone sensor	If any of the front air bags or seat belt pre-tensioners* have been activated: REPLACE the crash zone sensor and bracket with new fasteners. *: Confirm seat belt pre-tensioner activation using CONSULT-III only.
Seat belt pre-tensioner assemblies (All applicable locations: buckle, retractor, lap outer)	If either the driver or passenger seat belt pre-tensioner* has been activated: REPLACE all seat belt pre-tensioner assemblies with new fasteners. *: Confirm seat belt pre-tensioner activation using CONSULT-III only.
Diagnosis sensor unit	If any of the SRS components have been activated: REPLACE the diagnosis sensor unit. Install with new fasteners.
Steering wheel	<ol style="list-style-type: none"> 1. Visually check steering wheel for deformities. 2. Check harness (built into steering wheel) and connectors for damage, and terminals for deformities. 3. Install driver air bag module into the steering wheel to check fit and alignment with the wheel. 4. Check steering wheel for excessive free play. 5. If no damage is found, reinstall. 6. If damaged – REPLACE.
Spiral cable	If the driver front air bag has deployed: REPLACE the spiral cable.
Occupant classification system (Passenger seat)	<ol style="list-style-type: none"> 1. Remove passenger seat assembly. 2. Check control unit case for dents, cracks or deformities. 3. Check connectors and pressure sensor tube for damage, and terminals for deformities. 4. Check seat frame and cushion pan for dents or deformities. 5. If no damage is found, reinstall seat with new fasteners. 6. If damaged – REPLACE seat cushion assembly with new fasteners.

COLLISION DIAGNOSIS

< BASIC INSPECTION >

Part	Inspection
Harness and connectors	<ol style="list-style-type: none"> 1. Check connectors for poor connection, damage, and terminals for deformities. 2. Check harness for binding, chafing, cuts, or deformities. 3. If no damage is found, reinstall the harness and connectors. 4. If damaged – REPLACE the damaged harness. Do not attempt to repair, splice or modify any SRS harness.
Instrument panel assembly	If the front passenger air bag has deployed: REPLACE the instrument panel assembly. (integrated type)

FOR FRONTAL COLLISION : When SRS is not activated in a collision

INFOID:000000006113081

CAUTION:

Due to varying models and option levels, not all parts listed in the chart below apply to all vehicles.

WORK PROCEDURE

1. Before performing any of the following steps, ensure that all vehicle body and structural repairs have been completed.
2. Check the SRS components using the table below:
Replace any SRS components showing visible signs of damage. (dents, cracks and deformation, etc.)
3. Perform self-diagnosis using CONSULT-III or air bag warning lamp. Refer to [SRC-14. "Description"](#) for details. Ensure entire SRS operates properly.
4. After the work is completed, perform self-diagnosis to check that no malfunction is detected. Refer to [SRC-14. "Description"](#).

SRS INSPECTION (FOR FRONTAL COLLISION)

Part	Inspection
Driver air bag module	<p>If the driver air bag has NOT been deployed:</p> <ol style="list-style-type: none"> 1. Remove driver air bag module. Check harness cover and connectors for damage, terminals for deformities, and harness for binding. 2. Install driver air bag module into the steering wheel to check fit and alignment with the wheel. 3. If no damage is found, reinstall with new fasteners. 4. If damaged – REPLACE. Install driver air bag module with new fasteners.
Front passenger air bag module (if equipped)	<p>If the front passenger air bag has NOT been deployed:</p> <ol style="list-style-type: none"> 1. Remove front passenger air bag module. Check harness cover and connectors for damage, terminals for deformities, and harness for binding. 2. Install front passenger air bag module into the instrument panel to check fit with the instrument panel. 3. If no damage is found, reinstall with new fasteners. 4. If damaged – REPLACE. Install front passenger air bag modules with new fasteners.
Crash zone sensor	<p>If the front air bags or seat belt pre-tensioners have NOT been activated:</p> <ol style="list-style-type: none"> 1. Remove the crash zone sensor. Check harness connectors for damage, terminals for deformities, and harness for binding. 2. Check for visible signs of damage (dents, cracks, deformation, etc.) of the crash zone sensor and bracket. 3. Install the crash zone sensor to check fit. 4. If no damage is found, reinstall with new fasteners. 5. If damaged – REPLACE the crash zone sensor and bracket with new fasteners.
Seat belt pre-tensioner assemblies (All applicable locations: buckle, retractor, lap outer)	<p>If the pre-tensioners have NOT been activated:</p> <ol style="list-style-type: none"> 1. Remove seat belt pre-tensioners. Check harness cover and connectors for damage, terminals for deformities, and harness for binding. 2. Check belts for damage and anchors for loose mounting. 3. Check retractor for smooth operation. 4. Check seat belt adjuster for damage. 5. Check for deformities of the center pillar inner. 6. If the center pillar inner has no damage, REPLACE the seat belt pre-tensioner assembly. 7. If no damage is found, reinstall seat belt pre-tensioner assembly. 8. If damaged – REPLACE. Install the seat belt pre-tensioners with new fasteners.

COLLISION DIAGNOSIS

< BASIC INSPECTION >

Part	Inspection
Diagnosis sensor unit	If none of the SRS components have been activated: 1. Check case for dents, cracks or deformities. 2. Check connectors for damage, and terminals for deformities. 3. If no damage is found, reinstall with new fasteners. 4. If damaged – REPLACE. Install diagnosis sensor unit with new fasteners.
Steering wheel	1. Visually check steering wheel for deformities. 2. Check harness (built into steering wheel) and connectors for damage, and terminals for deformities. 3. Install driver air bag module into the steering wheel to check fit and alignment with the wheel. 4. Check steering wheel for excessive free play. 5. If no damage is found, reinstall. 6. If damaged – REPLACE.
Spiral cable	If the driver front air bag has not deployed: 1. Visually check spiral cable and combination switch for damage. 2. Check connectors and protective tape for damage. 3. Check steering wheel for noise, binding or heavy operation. 4. If no damage is found, reinstall. 5. If damaged – REPLACE.
Occupant classification system (Passenger seat)	1. Remove passenger seat assembly. 2. Check control unit case for dents, cracks or deformities. 3. Check connectors and pressure sensor tube for damage, and terminals for deformities. 4. Check seat frame and cushion pan for dents or deformities. 5. If no damage is found, reinstall seat with new fasteners. 6. If damaged – REPLACE seat cushion assembly with new fasteners.
Harness and connectors	1. Check connectors for poor connection, damage, and terminals for deformities. 2. Check harness for binding, chafing, cuts, or deformities. 3. If no damage is found, reinstall the harness and connectors. 4. If damaged – REPLACE the damaged harness. Do not attempt to repair, splice or modify any SRS harness.
Instrument panel assembly	If the front passenger air bag has NOT deployed: 1. Visually check instrument panel assembly for damage. 2. If no damage is found, reinstall the instrument panel assembly. 3. If damaged – REPLACE the instrument panel assembly.

A
B
C
D
E
F
G
SR
I
J

FOR SIDE AND ROLLOVER COLLISION

FOR SIDE AND ROLLOVER COLLISION : When SRS is activated in a collision

INFOID:000000006113082

CAUTION:

Due to varying models and option levels, not all parts listed in the chart below apply to all vehicles.

WORK PROCEDURE

1. Before performing any of the following steps, ensure that all vehicle body and structural repairs have been completed.
2. Replace the following components:
 - Front seat back assembly (on the side on which side air bag is activated)
 - Door finisher (on the side on which door-mounted curtain air bag is activated)
 - Pop-up roll bar assemblies and pop-up roll bar covers
 - Side air bag (satellite) sensor LH/RH (on the side on which side air bag is activated)
 - Diagnosis sensor unit
 - Seat belt pre-tensioner assemblies
3. Check the SRS components and the related parts using the following table. Replace any SRS components and the related parts showing visible signs of damage. (dents, cracks, deformation, etc.)
4. Perform self-diagnosis using CONSULT-III and “AIR BAG” warning lamp. Refer to [SRC-14. "Description"](#) for details. Make sure entire SRS operates properly.
5. After the work is completed, perform self-diagnosis to check that no malfunction is detected. Refer to [SRC-14. "Description"](#).

K
L
M
N
O
P

COLLISION DIAGNOSIS

< BASIC INSPECTION >

SRS INSPECTION (FOR SIDE AND ROLLOVER COLLISION)

Part	Inspection
Side curtain air bag module LH	If the side curtain air bag LH has deployed: REPLACE the side curtain air bag module LH. Install with new fasteners.
Side curtain air bag module RH	If the side curtain air bag RH has deployed: REPLACE the side curtain air bag module RH. Install with new fasteners.
Front side air bag module LH	If the front side air bag LH has deployed: REPLACE front seatback assembly LH.
Front side air bag module RH	If the front side air bag RH has deployed: REPLACE front seatback assembly RH.
Side air bag (satellite) sensor (LH or RH)	If any of the SRS components have deployed: REPLACE the side air bag (satellite) sensor on the collision side with new fasteners.
Diagnosis sensor unit	If any of the SRS components have deployed: REPLACE the diagnosis sensor unit with new fasteners.
Seat belt pre-tensioner assemblies (All applicable locations: buckle, retractor, lap outer)	If either the driver or passenger seat belt pre-tensioner* has been activated: REPLACE all seat belt pre-tensioner assemblies with new fasteners. *: Confirm seat belt pre-tensioner activation using CONSULT-III only.
Center inner pillar	1. Check the center inner pillar on the collision side for damage (dents, cracks, deformation, etc.). 2. If damaged – REPAIR the center inner pillar.
Trim/headlining	1. Check for visible signs of damage (dents, cracks, deformation, etc.) of the interior trim on the collision side. 2. If damaged – REPLACE the damaged trim parts.
Door-mounted curtain air bag module LH	If the door-mounted curtain air bag module LH has deployed: REPLACE the door finisher LH and door-mounted curtain air bag module. Install with new fasteners.
Door-mounted curtain air bag module RH	If the door-mounted curtain air bag module RH has deployed: REPLACE the door finisher RH and door-mounted curtain air bag module. Install with new fasteners.
Pop-up roll bar assemblies	If the pop-up roll bar has deployed: REPLACE pop-up roll bar assemblies and pop-up roll bar covers. Install with new fasteners.

FOR SIDE AND ROLLOVER COLLISION : When SRS is not activated in a collision

INFOID:000000006113083

CAUTION:

Due to varying models and option levels, not all parts listed in the chart below apply to all vehicles.

WORK PROCEDURE

1. Before performing any of the following steps, ensure that all vehicle body and structural repairs have been completed.
2. Check the SRS components and the related parts using the following table.
 - If the front seat back assembly is damaged, the front seat back assembly must be replaced.
 - If the door finisher assembly is damaged, the door finisher assembly and door-mounted curtain air bag module must be replaced.
3. Perform self-diagnosis using CONSULT-III and “AIR BAG” warning lamp. Refer to [SRC-14. "Description"](#) for details. Make sure entire SRS operates properly.
4. After the work is completed, perform self-diagnosis to check that no malfunction is detected. Refer to [SRC-14. "Description"](#).

SRS INSPECTION (FOR SIDE AND ROLLOVER COLLISION)

COLLISION DIAGNOSIS

< BASIC INSPECTION >

Part	Inspection	
Side curtain air bag module LH	If the side curtain air bag LH has NOT deployed: 1. Check for visible signs of damage (dents, tears, deformation, etc.) of the center pillar on the collision side. 2. If damaged – Remove the side curtain air bag module LH. 3. Check for visible signs of damage (tears etc.) of the side curtain air bag module LH. 4. Check harness and connectors for damage, and terminals for deformities. 5. If no damage is found, reinstall the side curtain air bag module LH with new fasteners. 6. If damaged – REPLACE the side curtain air bag module LH with new fasteners.	A B C
Side curtain air bag module RH	If the side curtain air bag RH has NOT deployed: 1. Check for visible signs of damage (dents, tears, deformation, etc.) of the center pillar on the collision side. 2. If damaged – Remove the side curtain air bag module RH. 3. Check for visible signs of damage (tears etc.) of the side curtain air bag module RH. 4. Check harness and connectors for damage, and terminals for deformities. 5. If no damage is found, reinstall the side curtain air bag module RH with new fasteners. 6. If damaged – REPLACE the side curtain air bag module RH with new fasteners.	D E
Front side air bag module LH	If the front side air bag LH has NOT deployed: 1. Check for visible signs of damage (dents, tears, deformation, etc.) of the seat back on the collision side. 2. Check harness and connectors for damage, and terminals for deformities. 3. If damaged – REPLACE the front seatback assembly LH.	F
Front side air bag module RH	If the front side air bag RH has NOT deployed: 1. Check for visible signs of damage (dents, tears, deformation, etc.) of the seat back on the collision side. 2. Check harness and connectors for damage, and terminals for deformities. 3. If damaged – REPLACE the front seatback assembly RH.	G SR
Side air bag (satellite) sensor (LH or RH)	If none of the SRS components have been activated: 1. Remove the side air bag (satellite) sensor (LH or RH) on the collision side. Check harness connectors for damage, terminals for deformities, and harness for binding. 2. Check for visible signs of damage (dents, cracks, deformation, etc.) of the side air bag (satellite) sensor (LH or RH). 3. Install the side air bag (satellite) sensor (LH or RH) to check fit. 4. If no damage is found, reinstall the side air bag (satellite) sensor (LH or RH) with new fasteners. 5. If damaged – REPLACE the side air bag (satellite) sensor (LH or RH) with new fasteners.	I J
Diagnosis sensor unit	If none of the SRS components have been activated: 1. Check case and bracket for dents, cracks or deformities. 2. Check connectors for damage, and terminals for deformities. 3. If no damage is found, reinstall the diagnosis sensor unit with new fasteners. 4. If damaged – REPLACE the diagnosis sensor unit with new fasteners.	K L
Seat belt pre-tensioner assemblies (All applicable locations: buckle, retractor, lap outer)	If the pre-tensioners have NOT been activated: 1. Remove seat belt pre-tensioners. Check harness cover and connectors for damage, terminals for deformities, and harness for binding. 2. Check belts for damage and anchors for loose mounting. 3. Check retractor for smooth operation. 4. Check seat belt adjuster for damage. 5. Check for deformities of the center pillar inner. 6. If the center pillar inner has no damage, REPLACE the seat belt pre-tensioner assembly. 7. If no damage is found, reinstall seat belt pre-tensioner assembly. 8. If damaged – REPLACE. Install the seat belt pre-tensioners with new fasteners.	M N O
Seat (with front side air bag)	If the front LH or front RH side air bag modules have NOT deployed: 1. Visually check the seat on the collision side. 2. Remove the seat on the collision side and check the following for damage and deformities. - Harness, connectors and terminals - Frame and recliner (for front and rear seat), and also adjuster and slides (for front seat) 3. If no damage is found, reinstall the seat. 4. If damaged – REPLACE the damaged seat parts using new fasteners. If the front seat back is damaged, the front seat back assembly must be replaced.	P
Center inner pillar	1. Check the center inner pillar on the collision side for damage (dents, cracks, deformation, etc.). 2. If damaged – REPAIR the center inner pillar.	

COLLISION DIAGNOSIS

< BASIC INSPECTION >

Part	Inspection
Trim/headlining	<ol style="list-style-type: none"> 1. Check for visible signs of damage (dents, cracks, deformation, etc.) of the interior trim on the collision side. 2. If damaged – REPLACE the damaged trim parts.
Door-mounted curtain air bag module LH	<p>If the door-mounted curtain air bag LH has NOT deployed:</p> <ol style="list-style-type: none"> 1. Check for visible signs of damage (dents, tears, deformation, etc.) of the door finisher on the collision side. 2. If damaged – REPLACE the door finisher LH with new fasteners. 3. Check for visible signs of damaged (tears etc.) of the door-mounted curtain air bag module LH. 4. Check harness and connectors for damage, and terminals for deformities. 5. If no damage is found, reinstall door finisher. CAUTION: When removing door-mounted curtain air bag module from door finisher, never reuse door finisher. 6. If damaged – REPLACE the door finisher LH and door-mounted curtain air bag module LH with new fasteners.
Door-mounted curtain air bag module RH	<p>If the door-mounted curtain air bag RH has NOT deployed:</p> <ol style="list-style-type: none"> 1. Check for visible signs of damage (dents, tears, deformation, etc.) of the door finisher on the collision side. 2. If damaged – REPLACE the door finisher RH with new fasteners. 3. Check for visible signs of damage (tears etc.) of the door-mounted curtain air bag module RH. 4. Check harness and connectors for damage, and terminals for deformities. 5. If no damage is found, reinstall door finisher. CAUTION: When removing door-mounted curtain air bag module from door finisher, never reuse door finisher. 6. If damaged – REPLACE the door finisher RH and door-mounted curtain air bag module RH with new fasteners.
Pop-up roll bar	<p>If the pop-up roll bar has NOT deployed:</p> <ol style="list-style-type: none"> 1. Check for visible signs of damage (dents, tears, deformation, etc.) of the pop-up roll bar. 2. If damaged – REPLACE the pop-up roll bar with new fasteners. 3. Check harness and connectors for damage, and terminals for deformities. 4. If no damage is found, reinstall the pop-up roll bar with new fasteners. 5. Check for visible signs of damage (dents, cracks, deformation, etc.) of the seatback support brace assembly. 6. If damaged – REPAIR the seatback support brace assembly.

DRIVER AIR BAG MODULE

< REMOVAL AND INSTALLATION >

REMOVAL AND INSTALLATION

DRIVER AIR BAG MODULE

Exploded View

INFOID:000000006113051

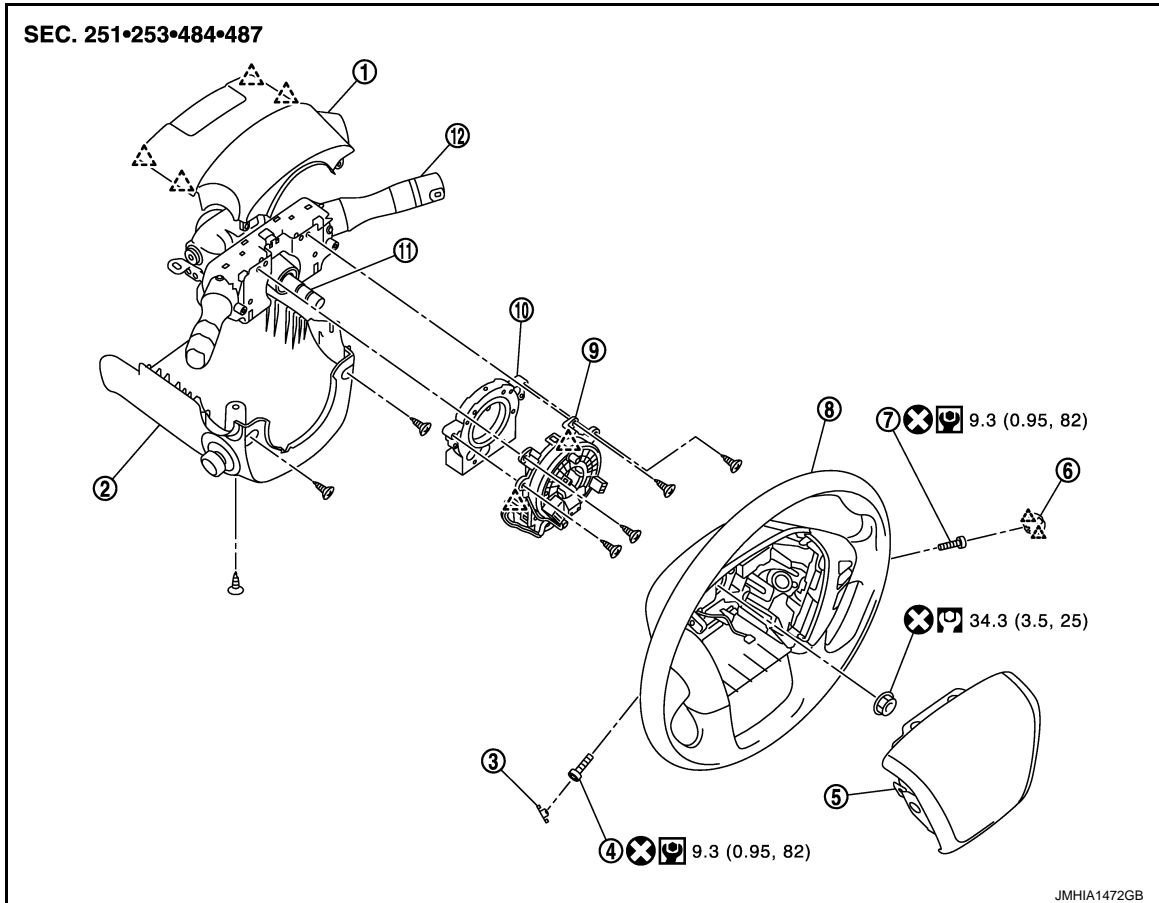

- | | | |
|--------------------------------|--------------------------------|------------------------|
| 1. Steering column upper cover | 2. Steering column lower cover | 3. Side lid LH |
| 4. TORX bolt LH | 5. Driver air bag module | 6. Side lid RH |
| 7. TORX bolt RH | 8. Steering wheel | 9. Spiral cable |
| 10. Steering angle sensor | 11. Steering column assembly | 12. Combination switch |

 : Pawl

Refer to [GI-4, "Components"](#) for symbols in the figure.

Removal and Installation

INFOID:000000006113052

WARNING:

- Before servicing, turn ignition switch OFF, disconnect battery negative terminal and wait 3 minutes or more.
- Always work from the side of air bag module. Never work in front of it.
- Never use the air tools or electric tools for servicing.

REMOVAL

1. Remove the side lids (LH/RH).
2. Remove the driver air bag module mounting TORX bolts (LH/RH).
3. Pull out the driver air bag module.

DRIVER AIR BAG MODULE

< REMOVAL AND INSTALLATION >

4. Disconnect the driver air bag module harness connector.

CAUTION:

- For installing/removing the driver air bag module harness connector, insert thin screwdriver wrapped in tape into notch, lift lock and remove the connector.
- Install the connector with lock raised, and push lock into the connector.
- After installing the connector, check that the lock is pushed securely into it.

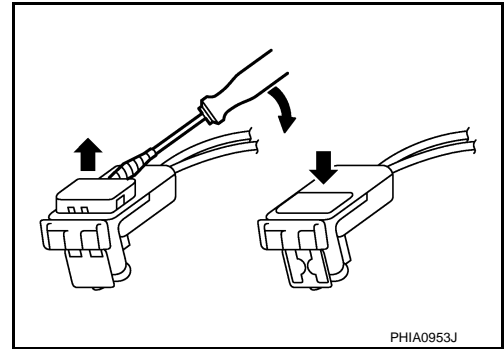

5. Remove the driver air bag module.

CAUTION:

- Always place the driver air bag module with pad side facing upward.

↖ : Upward

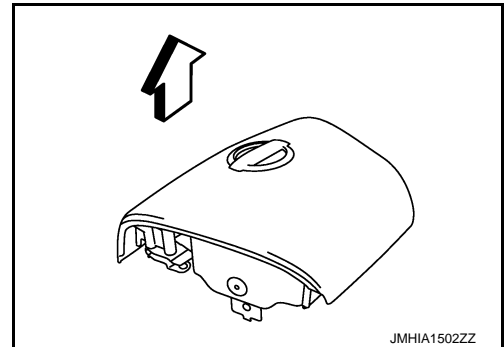

- Never impact the driver air bag module.
- Replace the driver air bag module if it has been dropped or sustained an impact.



- Never insert any foreign objects (screwdriver, etc.) into the driver air bag module.
- Never disassemble the driver air bag module.
- Never expose the driver air bag module to temperatures exceeding 90 °C (194 °F).
- Never allow oil, grease, detergent, or water to come in contact with the driver air bag module.

INSTALLATION

Note the following item, and install in the reverse order of removal.

CAUTION:

- Never use the old TORX bolts after removal, replace with the new TORX bolts.
- Fix the driver air bag module harness to the harness fixing hook (A).

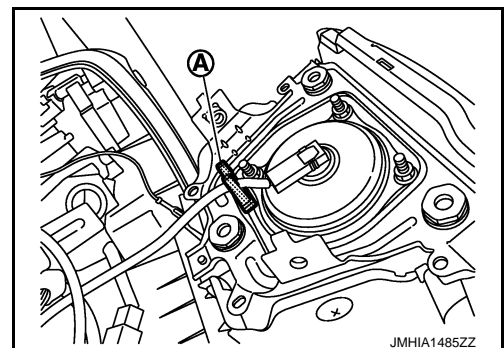

DRIVER AIR BAG MODULE

< REMOVAL AND INSTALLATION >

- Tighten the TORX bolts after completely adjusting the centers of fixing holes on the driver air bag module side and the steering wheel side. If the holes are misaligned, the bolt threads are damaged and the module is not installed securely.
- Never damage the harness while installing.
- If malfunction is detected by the air bag warning lamp, after repair or replacement of the malfunctioning parts, reset the memory using self-diagnosis or CONSULT-III. Refer to [SRC-14, "On Board Diagnosis Function"](#) or [SRC-19, "CONSULT-III Function"](#).
- After the work is completed, check that no system malfunction is detected by air bag warning lamp.

A

B

C

D

E

F

G

SR

I

J

K

L

M

N

O

P

SPIRAL CABLE

< REMOVAL AND INSTALLATION >

SPIRAL CABLE

Exploded View

INFOID:000000006113053

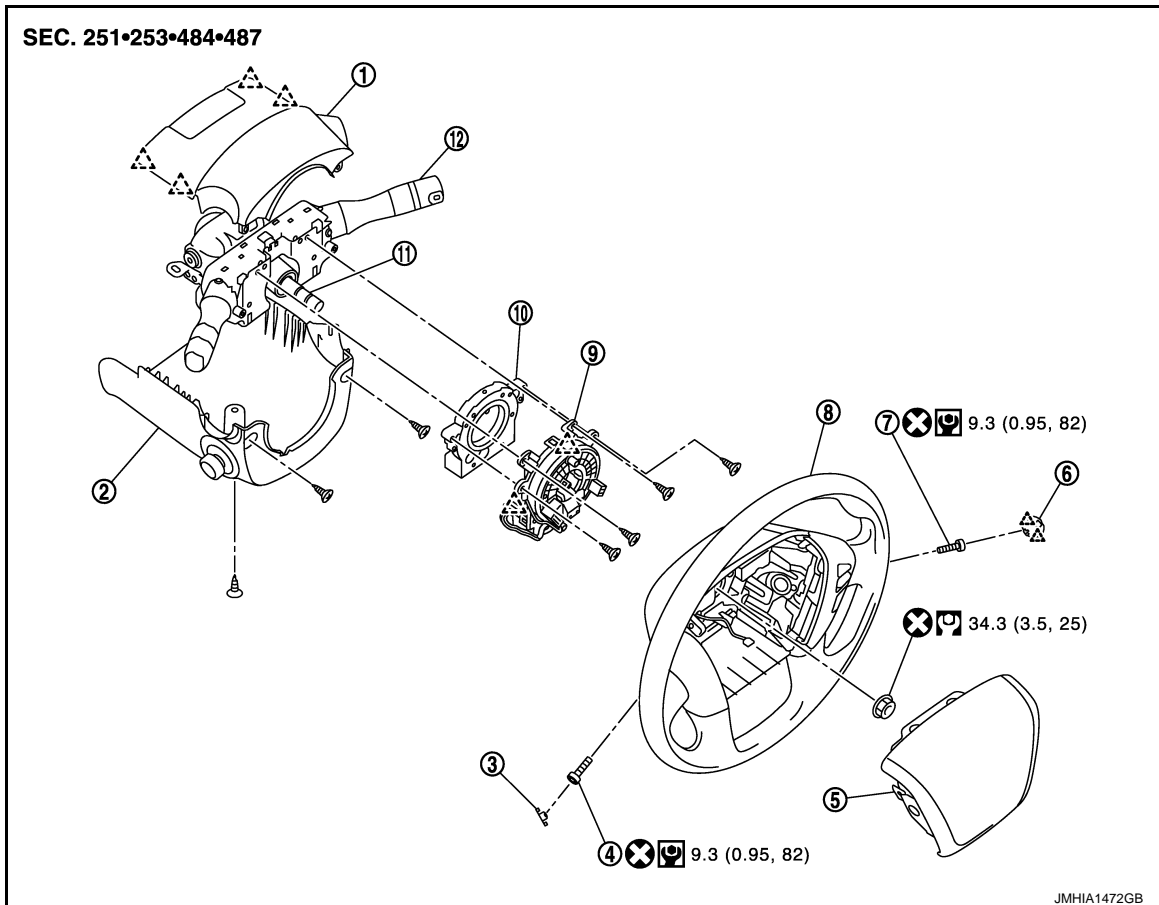

- | | | |
|--------------------------------|--------------------------------|------------------------|
| 1. Steering column upper cover | 2. Steering column lower cover | 3. Side lid LH |
| 4. TORX bolt LH | 5. Driver air bag module | 6. Side lid RH |
| 7. TORX bolt RH | 8. Steering wheel | 9. Spiral cable |
| 10. Steering angle sensor | 11. Steering column assembly | 12. Combination switch |

 : Pawl

Refer to [GI-4. "Components"](#) for symbols in the figure.

Removal and Installation

INFOID:000000006113054

WARNING:

- Before servicing, turn ignition switch OFF, disconnect battery negative terminal and wait 3 minutes or more.
- Never use the air tools or electric tools for servicing.

REMOVAL

1. Remove the driver air bag module. Refer to [SR-11. "Removal and Installation"](#).
2. Remove the steering wheel. Refer to [ST-33. "Removal and Installation"](#).
3. Remove the steering column upper cover and steering column lower cover. Refer to [IP-14. "Removal and Installation"](#).

SPIRAL CABLE

< REMOVAL AND INSTALLATION >

4. Disconnect the spiral cable body side harness connectors (A) and steering angle sensor harness connector (B).

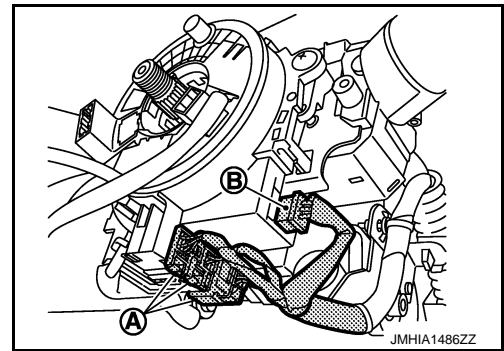

5. Remove the spiral cable fixing screws.
6. Pull out forward the spiral cable and steering sensor.
7. Remove steering angle sensor. Refer to [BRC-139. "Removal and Installation"](#).

CAUTION:

- Never impact the spiral cable.
- Replace the spiral cable if it has been dropped or sustained an impact.



- Never disassemble the spiral cable.
- Never apply lubricant to the spiral cable.
- Never allow oil, grease, detergent, or water to come in contact with the spiral cable.

INSTALLATION

Note the following item, and install in the reverse order of removal.

CAUTION:

- The spiral cable may snap during steering operation if the cable is installed in an improper position. The neutral position is set as follows.
- Carefully turn the spiral cable clockwise to the end position. Then turn it counterclockwise (about 2 and a half turns) and stop turning at the mark (B) on which the stopper insertion holes are in the same position.
- The service part is installed in the neutral position by the stopper and can be set without adjusting after the stopper is removed.
- Never over turn the spiral cable or go beyond the number of turns required. (These will cause the cable to snap.)
- Adjust the spiral cable locating pin (A) to the steering wheel locating pin hole (C).

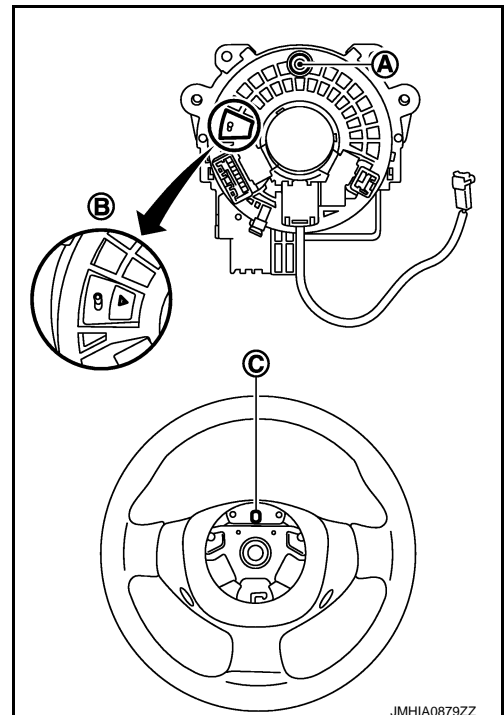

SPIRAL CABLE

< REMOVAL AND INSTALLATION >

- Fix the driver air bag module harnesses to the harness fixing hook (A).

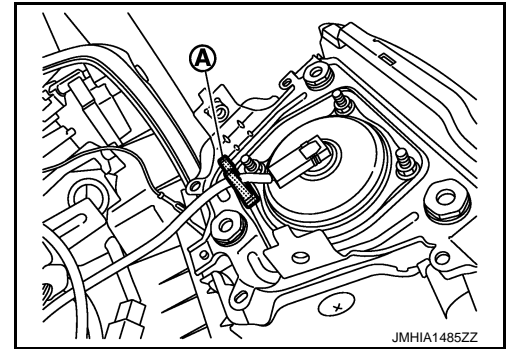

- If malfunction is detected by the air bag warning lamp, after repair or replacement of the malfunctioning parts, reset the memory using self-diagnosis or CONSULT-III. Refer to [SRC-14, "On Board Diagnosis Function"](#) or [SRC-19, "CONSULT-III Function"](#).
- After the work is completed, check that no system malfunction is detected by air bag warning lamp.

FRONT PASSENGER AIR BAG MODULE

< REMOVAL AND INSTALLATION >

FRONT PASSENGER AIR BAG MODULE

Exploded View

INFOID:000000006113055

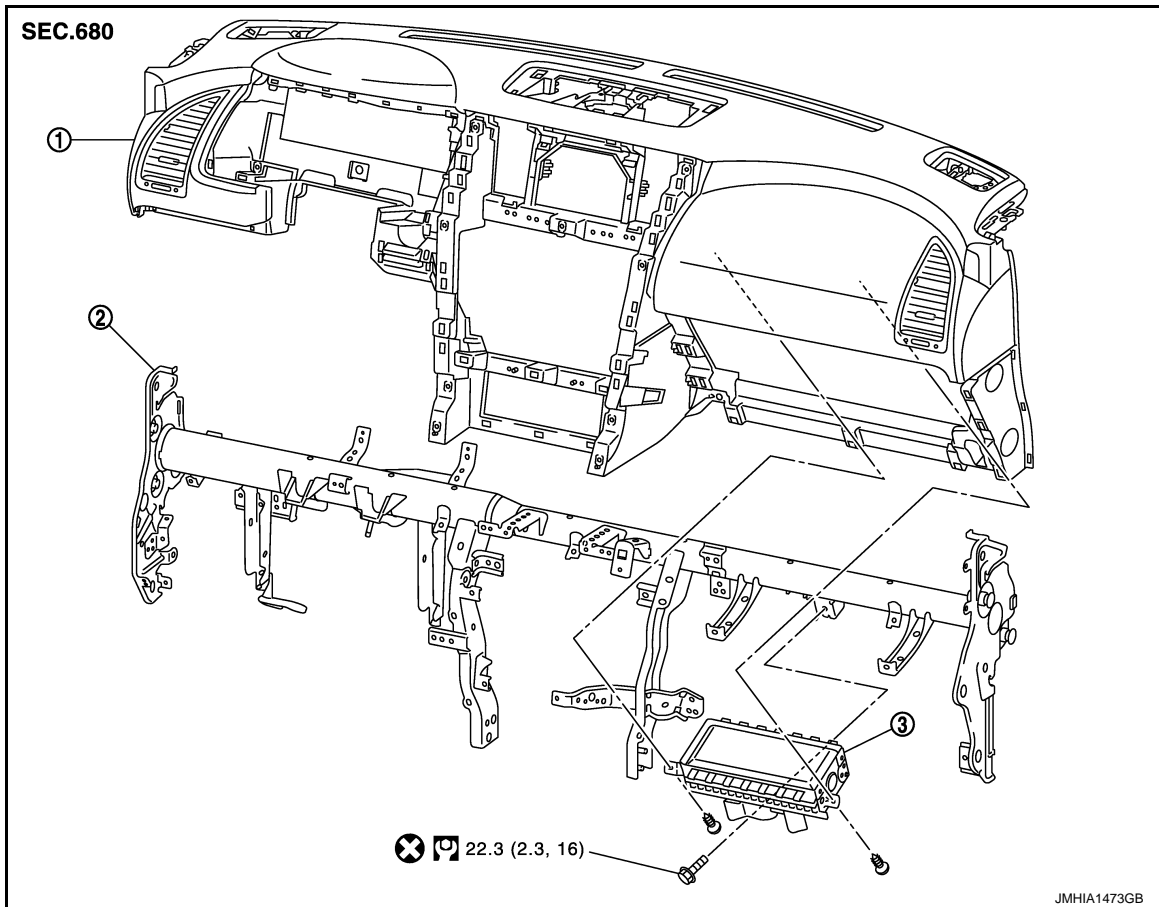

1. Instrument panel assembly 2. Steering member assembly 3. Front passenger air bag module

Refer to [GI-4, "Components"](#) for symbols in the figure.

Removal and Installation

INFOID:000000006113056

WARNING:

- Before servicing, turn ignition switch OFF, disconnect battery negative terminal and wait 3 minutes or more.
- Always work from the side of air bag module. Never work in front of it.
- Never use the air tools or electric tools for servicing.

REMOVAL

1. Remove the instrument panel assembly. Refer to [IP-14, "Removal and Installation"](#).
2. Remove the front passenger air bag module fixing screws (A).

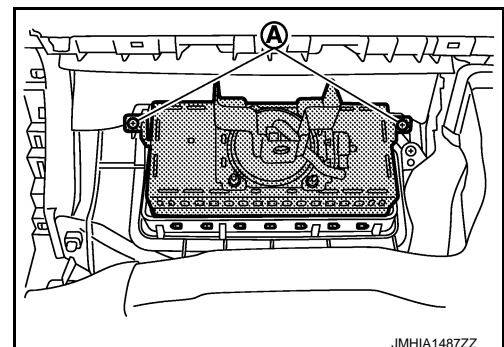

FRONT PASSENGER AIR BAG MODULE

< REMOVAL AND INSTALLATION >

3. Disconnect the front passenger air bag module fixing pawls with remover tool (A).
4. Lift up front passenger air bag module, and then remove front passenger air bag module.

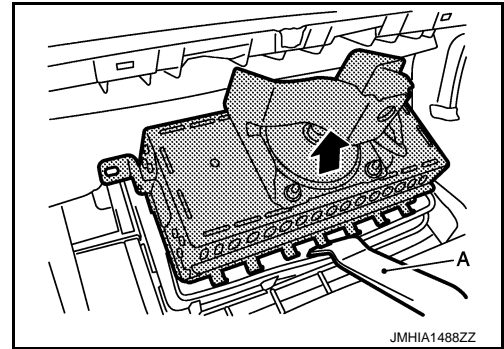

CAUTION:

- Always place the front passenger air bag module with pad side facing upward.

⇐ : Upward

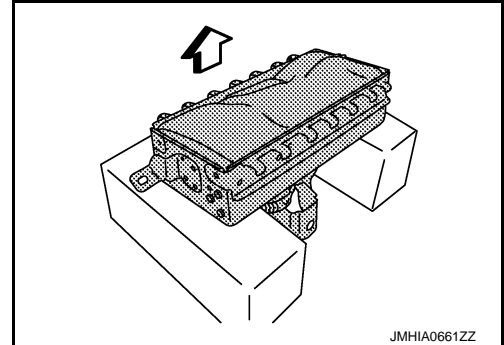

- Never impact the front passenger air bag module.
- Replace the front passenger air bag module if it has been dropped or sustained an impact.



- Never insert any foreign objects (screwdriver, etc.) into the front passenger air bag module.
- Never disassemble the front passenger air bag module.
- Never expose the front passenger air bag module to temperatures exceeding 90 °C (194 °F).
- Never allow oil, grease, detergent, or water to come in contact with the front passenger air bag module.

INSTALLATION

Note the following item, and install in the reverse order of removal.

CAUTION:

- Never use the old fixing bolts after removal, replace with the new bolts.
- Never damage the harness while installing.
- If malfunction is detected by the air bag warning lamp, after repair or replacement of the malfunctioning parts, reset the memory using self-diagnosis or CONSULT-III. Refer to [SRC-14, "On Board Diagnosis Function"](#) or [SRC-19, "CONSULT-III Function"](#).
- After the work is completed, check that no system malfunction is detected by air bag warning lamp.

SIDE CURTAIN AIR BAG MODULE

< REMOVAL AND INSTALLATION >

SIDE CURTAIN AIR BAG MODULE

Exploded View

INFOID:000000006113059

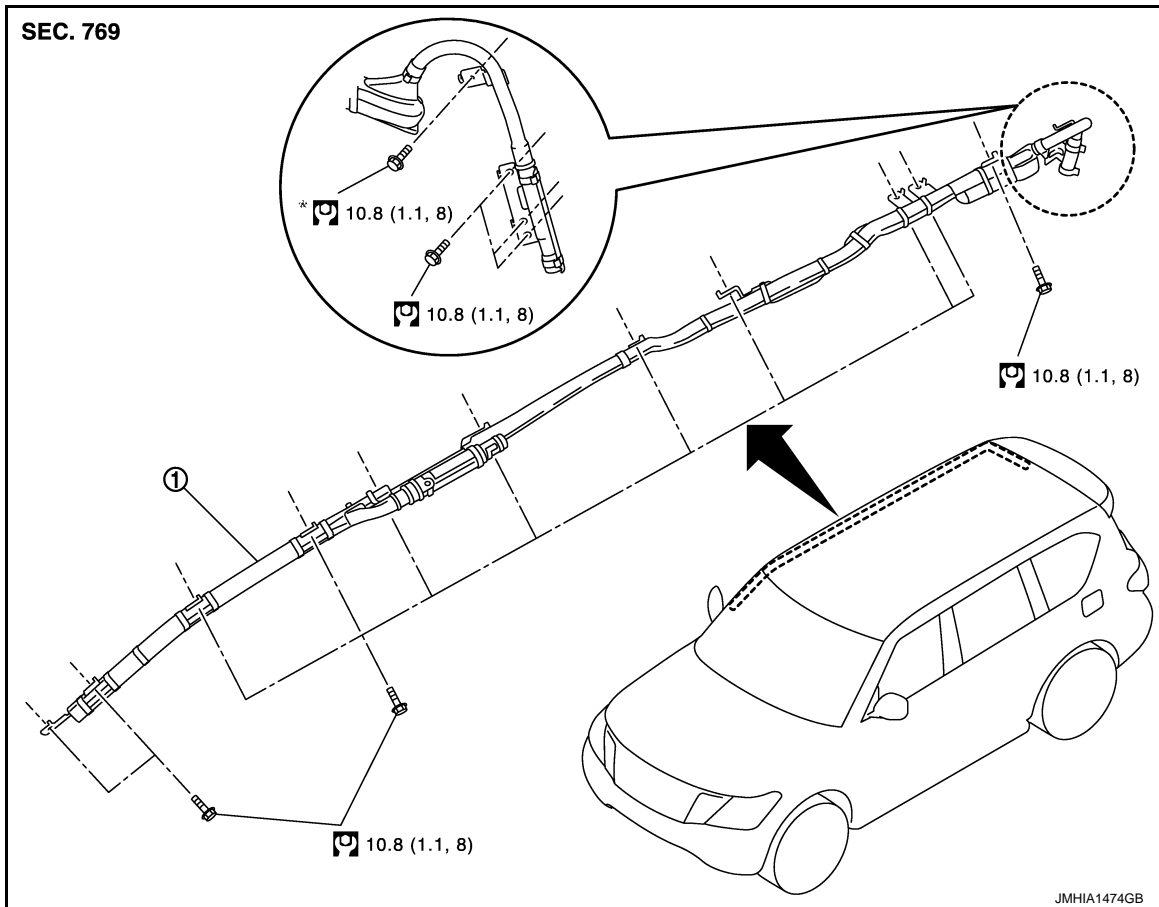

1. Side curtain air bag

*: Side curtain air bag RH side only

Refer to [GI-4, "Components"](#) for symbols in the figure.

Removal and Installation

INFOID:000000006113060

WARNING:

- Before servicing, turn ignition switch OFF, disconnect battery negative terminal and wait 3 minutes or more.
- Always work from the side of air bag module. Never work in front of it.
- Never use the air tools or electric tools for servicing.

REMOVAL

1. Remove the headlining assembly. Refer to [INT-29, "Removal and Installation"](#).
2. Remove the side curtain air bag module harness connector.

CAUTION:

A
B
C
D
E
F
G
SR
I
J
K
L
M
N
O
P

SIDE CURTAIN AIR BAG MODULE

< REMOVAL AND INSTALLATION >

- For installing/removing the side curtain air bag module harness connector, insert thin screwdriver wrapped in tape into notch, lift lock and remove the connector.
- Install the connector with lock raised, and push lock into the connector.
- After installing the connector, check that the lock is pushed securely into it.

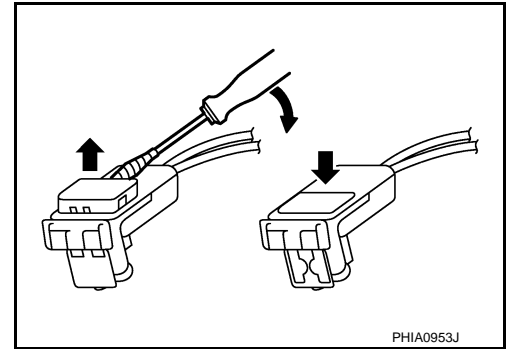

3. Remove the side curtain air bag module fixing bolts, and then remove the side curtain air bag module.

CAUTION:

- Never impact the side curtain air bag module.
- Replace the side curtain air bag module if it has been dropped or sustained an impact.



- Never insert any foreign objects (screwdriver, etc.) into the side curtain air bag module.
- Never disassemble the side curtain air bag module.
- Never expose the side curtain air bag module to temperatures exceeding 90 °C (194 °F).
- Never allow oil, grease, detergent, or water to come in contact with the side curtain air bag module.

INSTALLATION

Note the following item, and install in the reverse order of removal.

CAUTION:

- when installing, always be careful not to drop side curtain air bag module and install mounting bolts according to the order as shown in the figure.

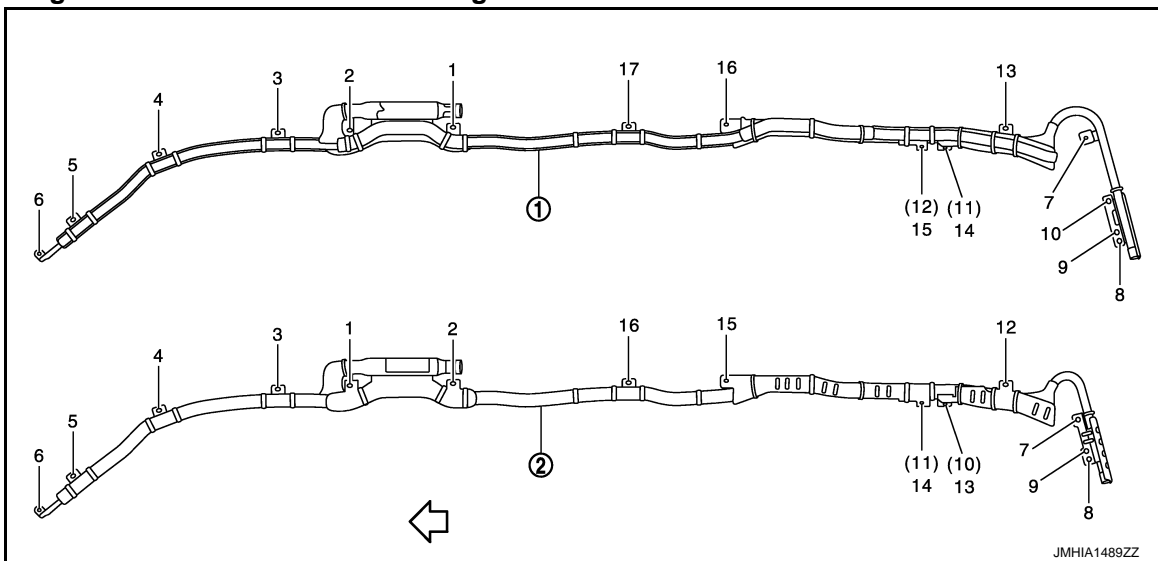

1. Side curtain air bag module RH 2. Side curtain air bag module LH

← : Vehicle front

(): Peel and stop of, temporary.

SIDE CURTAIN AIR BAG MODULE

< REMOVAL AND INSTALLATION >

- Never damage the harness while installing.
- If malfunction is detected by the air bag warning lamp, after repair or replacement of the malfunctioning parts, reset the memory using self-diagnosis or CONSULT-III. Refer to [SRC-14, "On Board Diagnosis Function"](#) or [SRC-19, "CONSULT-III Function"](#).
- After the work is completed, check that no system malfunction is detected by air bag warning lamp.

A

B

C

D

E

F

G

SR

I

J

K

L

M

N

O

P

CRASH ZONE SENSOR

< REMOVAL AND INSTALLATION >

CRASH ZONE SENSOR

Exploded View

INFOID:000000006216179

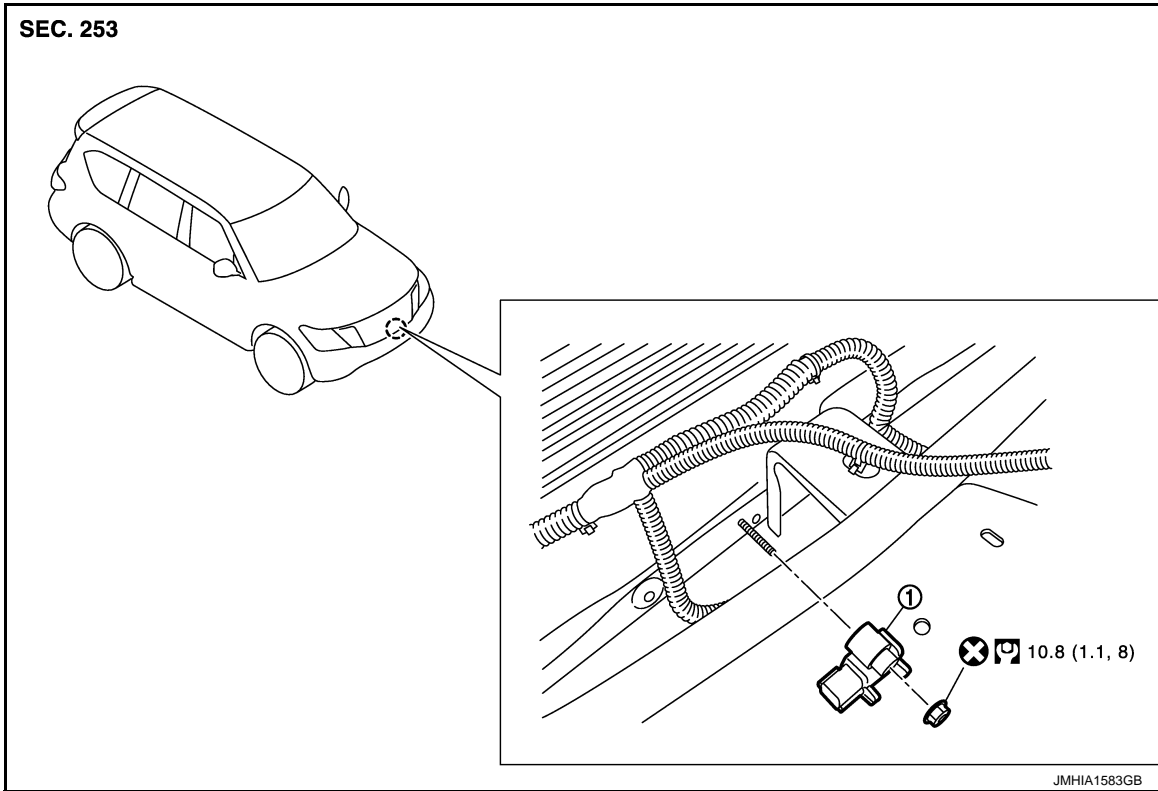

1. Crash zone sensor

Refer to [GI-4. "Components"](#) for symbols in the figure.

Removal and Installation

INFOID:000000006216180

WARNING:

- Before servicing, turn ignition switch OFF, disconnect battery negative terminal and wait 3 minutes or more.
- Never use the air tools or electric tools for servicing.

REMOVAL

1. Remove the front under cover. Refer to [EXT-25. "Removal and Installation"](#).
2. Disconnect the crash zone sensor harness connector.
3. Remove the crash zone sensor fixing nut, and then remove crash zone sensor.

CAUTION:

- Never impact the crash zone sensor.
- Replace the crash zone sensor if it has been dropped or sustained an impact.



CRASH ZONE SENSOR

< REMOVAL AND INSTALLATION >

- Replace the crash zone sensor of deployed driver air bag and deployed front passenger air bag.

INSTALLATION

Note the following item, and install in the reverse order of removal.

CAUTION:

- Never use the old fixing nut after removal, replace with the new nut.
- Never damage the harness connector while installing.
- If malfunction is detected by the air bag warning lamp, after repair or replacement of the malfunctioning parts, reset the memory using self-diagnosis or CONSULT-III. Refer to [SRC-14, "On Board Diagnosis Function"](#) or [SRC-19, "CONSULT-III Function"](#).
- After the work is completed, check that no system malfunction is detected by air bag warning lamp.

A
B
C
D
E
F
G
I
J
K
L
M
N
O
P

SR

SIDE AIR BAG (SATELLITE) SENSOR

< REMOVAL AND INSTALLATION >

SIDE AIR BAG (SATELLITE) SENSOR

Exploded View

INFOID:000000006113063

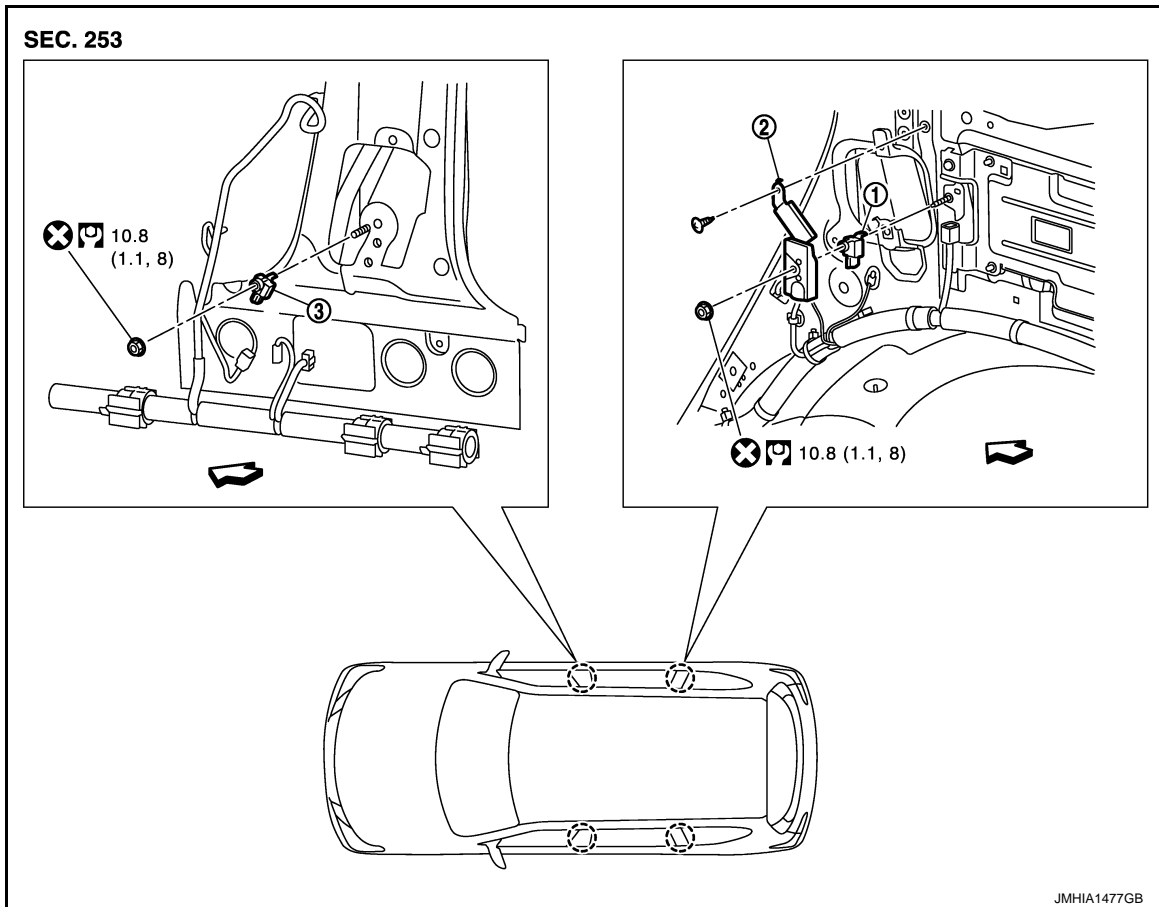

1. Side air bag rear (satellite) sensor 2. Bracket * 3. Side air bag front (satellite) sensor

↔ : Vehicle front

*: Side air bag rear (satellite) sensor RH side only

Refer to [GI-4. "Components"](#) for symbols in the figure.

Removal and Installation

INFOID:000000006113064

WARNING:

- Before servicing, turn ignition switch OFF, disconnect battery negative terminal and wait 3 minutes or more.
- Never use the air tools or electric tools for servicing.

REMOVAL

SIDE AIR BAG FRONT (SATELLITE) SENSOR LH

1. Remove the center pillar lower garnish LH. Refer to [INT-22. "CENTER PILLAR LOWER GARNISH : Removal and Installation"](#).
2. Remove the side air bag front (satellite) sensor LH fixing nut.
3. Disconnect the side air bag front (satellite) sensor LH harness connector, and then remove side air bag front (satellite) sensor LH.

SIDE AIR BAG FRONT (SATELLITE) SENSOR RH

1. Remove the center pillar lower garnish RH. Refer to [INT-22. "CENTER PILLAR LOWER GARNISH : Removal and Installation"](#).

SIDE AIR BAG (SATELLITE) SENSOR

< REMOVAL AND INSTALLATION >

2. Remove the front seat belt retractor. Refer to [SB-6, "SEAT BELT RETRACTOR : Removal and Installation"](#).
3. Remove the side air bag front (satellite) sensor RH fixing nut.
4. Disconnect the side air bag front (satellite) sensor RH harness connector, and then remove side air bag front (satellite) sensor RH.

SIDE AIR BAG REAR (SATELLITE) SENSOR LH

1. Remove the luggage side lower finisher LH. Refer to [INT-36, "LUGGAGE SIDE LOWER FINISHER : Removal and Installation"](#).
2. Remove the side air bag rear (satellite) sensor LH fixing nut.
3. Disconnect the side air bag rear (satellite) sensor LH harness connector, and then remove side air bag rear (satellite) sensor LH.

SIDE AIR BAG REAR (SATELLITE) SENSOR RH

1. Remove the luggage side lower finisher RH. Refer to [INT-36, "LUGGAGE SIDE LOWER FINISHER : Removal and Installation"](#).
2. Remove the shield bracket fixing screw, and then remove shield bracket.
3. Remove the side air bag rear (satellite) sensor RH fixing nut.
4. Disconnect the side air bag rear (satellite) sensor RH harness connector, and then remove side air bag rear (satellite) sensor RH.

CAUTION:

- Never impact the side air bag (satellite) sensor.
- Replace the side air bag (satellite) sensor if it has been dropped or sustained an impact.



- Replace the satellite sensor of deployed front side air bag module and deployed side curtain air bag module.

INSTALLATION

Note the following item, and install in the reverse order of removal.

CAUTION:

- Never use the old fixing nut after removal, replace with the new nut.
- Never damage the harness connector while installing
- If malfunction is detected by the air bag warning lamp, after repair or replacement of the malfunctioning parts, reset the memory using self-diagnosis or CONSULT-III. Refer to [SRC-14, "On Board Diagnosis Function"](#) or [SRC-19, "CONSULT-III Function"](#).
- After the work is completed, check that no system malfunction is detected by air bag warning lamp.

DIAGNOSIS SENSOR UNIT

< REMOVAL AND INSTALLATION >

DIAGNOSIS SENSOR UNIT

Exploded View

INFOID:000000006113065

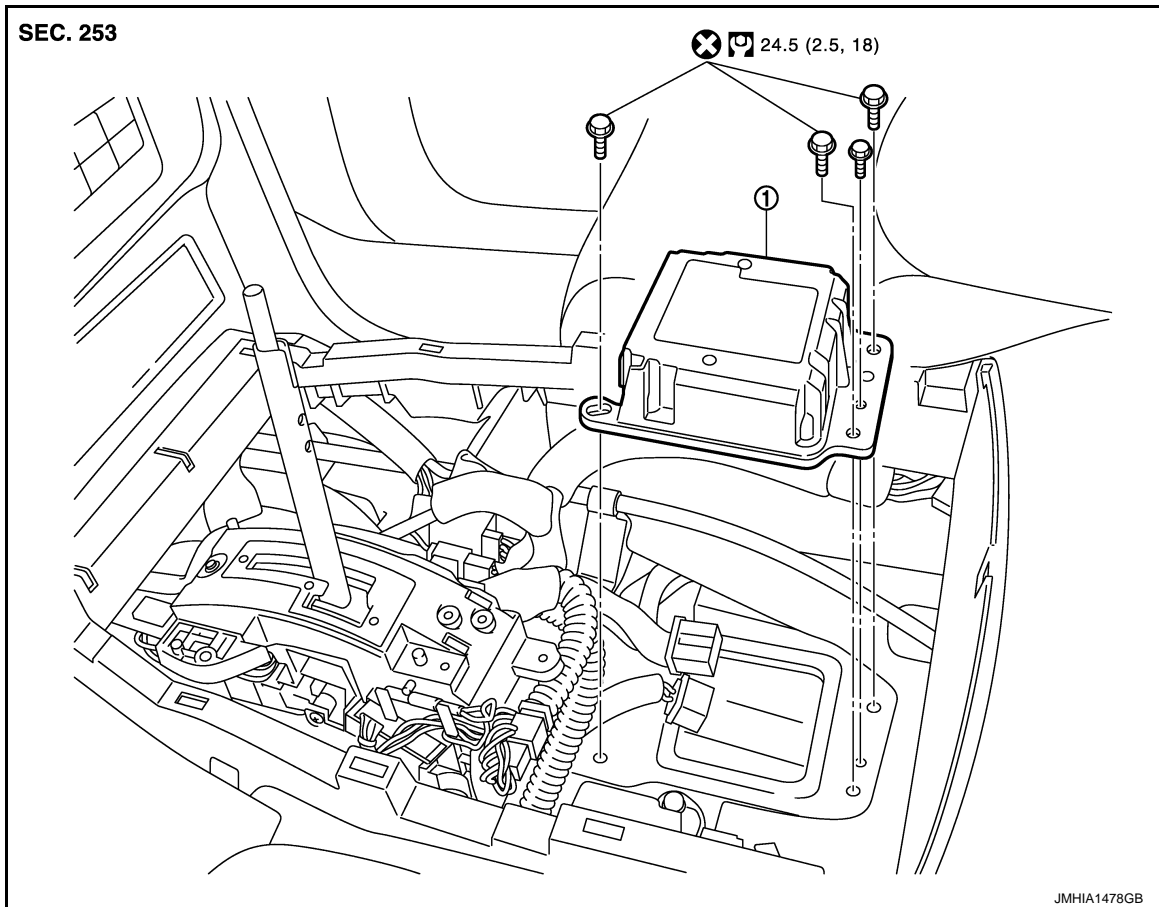

1. Diagnosis sensor unit

Refer to [GI-4, "Components"](#) for symbols in the figure.

Removal and Installation

INFOID:000000006113066

WARNING:

- Before servicing, turn ignition switch OFF, disconnect battery negative terminal and wait 3 minutes or more.
- Before disconnecting the air bag diagnosis sensor unit harness connectors, be sure to disconnect the each harness connector of the air bag module and seat belt pre-tensioner to prevent air bag deployment by static electricity and seat belt pre-tensioner operation.
- Never use the air tools or electric tools for servicing.
- When replacing the air bag diagnosis sensor unit, always check with the parts department for the latest parts information. Installing an incorrect air bag diagnosis sensor unit may or may not cause the air bag warning lamp to illuminate and may cause incorrect deployment of the supplemental air bags and seat belt pre-tensioners in a collision resulting in serious personal injury or death.

REMOVAL

1. Always check the air bag diagnosis sensor unit ECU discriminated number (identification number) using CONSULT-III.
2. Disconnect the each connector of all air bag modules and pre-tensioner seat belts.
3. Remove the console finisher assembly. Refer to [IP-25, "Removal and Installation"](#).
4. Remove the diagnosis sensor unit fixing bolts, ground bolt, and then remove diagnosis sensor unit.
5. Disconnect the diagnosis sensor unit harness connector.

DIAGNOSIS SENSOR UNIT

< REMOVAL AND INSTALLATION >

CAUTION:

- Never impact the diagnosis sensor unit.
- Replace the diagnosis sensor unit if it has been dropped or sustained an impact.

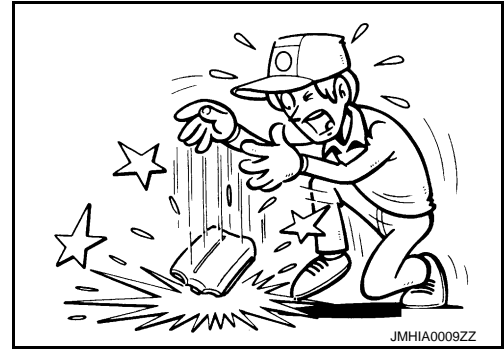

- Replace the diagnosis sensor unit of deployed SRS air bag and deployed front seat belt pretensioner.

INSTALLATION

Install in the reverse order of removal.

CAUTION:

- Never use the old fixing bolts after removal, replace with the new bolts.
- Never damage the harness connector while installing.
- If malfunction is detected by the air bag warning lamp, after repair or replacement of the malfunctioning parts, reset the memory using self-diagnosis or CONSULT-III. Refer to [SRC-14, "On Board Diagnosis Function"](#) or [SRC-19, "CONSULT-III Function"](#).
- After the work is completed, check that no system malfunction is detected by air bag warning lamp.
- After replacing the air bag diagnosis sensor unit, confirm using CONSULT-III that the ECU discriminated number (identification number) of the new replacement air bag sensor unit matches the ECU discriminated number (identification number) of the replaced (old) air bag diagnosis sensor unit.

NOTE:

If the ECU discriminated number of the new replacement air bag diagnosis sensor unit differs from the ECU discriminated number of the replaced air bag diagnosis sensor unit, reconfirm the parts information and verify that the correct air bag diagnosis sensor unit was installed.

A
B
C
D
E
F
G
SR
I
J
K
L
M
N
O
P

SEAT BELT PRE-TENSIONER

< REMOVAL AND INSTALLATION >

SEAT BELT PRE-TENSIONER

Exploded View

INFOID:000000006113067

Refer to [SB-6. "SEAT BELT RETRACTOR : Exploded View"](#).

Removal and Installation

INFOID:000000006113068

For removal and installation procedures, refer to [SB-6. "SEAT BELT RETRACTOR : Removal and Installation"](#).

LAP PRE-TENSIONER

< REMOVAL AND INSTALLATION >

LAP PRE-TENSIONER

Exploded View

INFOID:000000006418803

Refer to [SB-6. "SEAT BELT RETRACTOR : Exploded View"](#).

Removal and Installation

INFOID:000000006156561

For removal and installation procedures, refer to [SB-8. "SEAT BELT BUCKLE : Removal and Installation"](#).

A
B
C
D
E
F
G
SR
I
J
K
L
M
N
O
P

OCCUPANT DETECTION SYSTEM CONTROL UNIT

< REMOVAL AND INSTALLATION >

OCCUPANT DETECTION SYSTEM CONTROL UNIT

Exploded View

INFOID:000000006156560

Refer to [SE-105, "Exploded View"](#).

Removal and Installation

INFOID:000000006113084

1. Remove passenger seat assembly. Refer to [SE-112, "Removal and Installation"](#).
2. Remove occupant detection system control unit mounting bolts.
3. Remove occupant detection system control unit harness connector, and then remove occupant detection system control unit.