

SECTION **FL**
FUEL SYSTEM

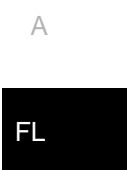

CONTENTS

PRECAUTION	2	Removal and Installation	5	F
PRECAUTIONS	2	Inspection	8	
General Precautions	2	FUEL TANK	9	G
PREPARATION	3	Exploded View	9	
PREPARATION	3	Removal and Installation	9	
Special Service Tool	3	Inspection	10	H
Commercial Service Tools	3	EVAP CANISTER	11	
PERIODIC MAINTENANCE	4	Exploded View	11	I
FUEL SYSTEM	4	Hydraulic Layout	11	
Inspection	4	Removal and Installation	13	J
Quick Connector	4	Disassembly and Assembly	13	
REMOVAL AND INSTALLATION	5	Inspection	13	J
FUEL LEVEL SENSOR UNIT, FUEL FILTER		SERVICE DATA AND SPECIFICATIONS		
AND FUEL PUMP ASSEMBLY	5	(SDS)	14	K
Exploded View	5	SERVICE DATA AND SPECIFICATIONS		
		(SDS)	14	L
		Fuel Tank	14	L

A
C
D
E
F
G
H
I
J
K
L
M
N
O
P

PRECAUTIONS

< PRECAUTION >

PRECAUTION

PRECAUTIONS

General Precautions

INFOID:000000007378399

WARNING:

When replacing fuel line parts, be sure to observe the following.

- Put a “CAUTION: FLAMMABLE” sign in the workshop.
- Be sure to work in a well ventilated area and furnish workshop with a CO2 fire extinguisher.
- Never smoke while servicing fuel system. Keep open flames and sparks away from the work area.

CAUTION:

- Use gasoline required by the regulations for octane number. Refer to [GI-33, "Fuel"](#).
- Before removing fuel line parts, perform out the following procedures:
 - Put drained fuel in an explosion-proof container and put the lid on securely. Keep the container in safe area.
 - Release fuel pressure from the fuel lines. Refer to the following table:

ENGINE	Reference page
VK56VD FOR USA AND CANADA	EC-150, "Work Procedure"
VK56VD FOR MEXICO	EC-697, "Work Procedure"

- Disconnect the battery cable from the negative terminal.
- Always replace O-rings with new ones.
- Never kink or twist tubes when they are being installed.
- Never tighten hose clamps excessively to avoid damaging hoses.
- After installing tubes, check there is no fuel leakage at connections in the following steps.
 - Apply fuel pressure to fuel lines with turning ignition switch “ON” (with engine stopped). Then check for fuel leakage at connections.
 - Start engine and rev it up and check for fuel leakage at connections.
- Use only a genuine NISSAN fuel filler cap as a replacement. If an incorrect fuel filler cap is used, the “MIL” may come on.

PREPARATION

< PREPARATION >

PREPARATION

PREPARATION

Special Service Tool

INFOID:000000007378400

A

FL

Tool number (Kent-Moore No.) Tool name	Description
KV10119800 (J-45722) Fuel tank lock ring wrench	Removing and installing fuel tank rock ring a: 187 mm (7.36 in) NOTE: The actual shapes of Kent-Moore No. tools may differ from those of the special tools illustrated here.
KV10119801 (J-45722) Fuel tank lock ring wrench	

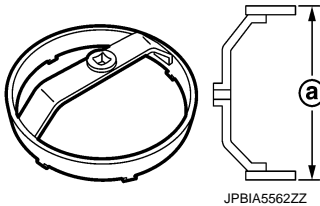
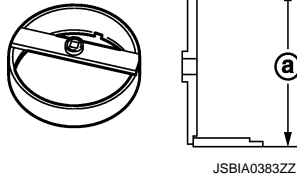

Commercial Service Tools

INFOID:000000007378401

Tool name	Description
Power tool	Loosening bolts and nuts

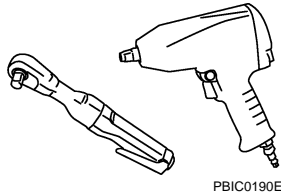

C

D

E

F

G

H

I

J

K

L

M

N

O

P

FUEL SYSTEM

< PERIODIC MAINTENANCE >

PERIODIC MAINTENANCE

FUEL SYSTEM

Inspection

INFOID:000000007378402

- Inspect fuel lines, fuel filler cap and fuel tank for improper attachment, leakage, cracks, damage, loose connections, chafing or deterioration.

- A : Engine
- B : Fuel line
- C : Fuel tank

- If necessary, repair or replace damaged parts.

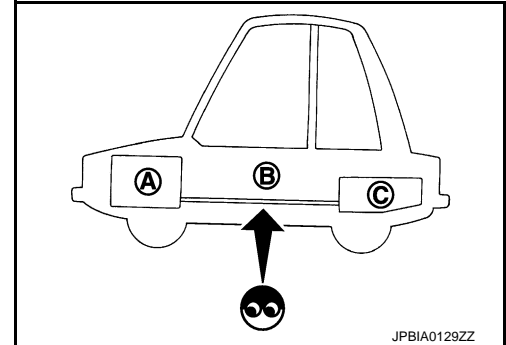

Quick Connector

INFOID:000000007378403

CAUTION:

- After connecting fuel tube quick connectors, check quick connectors are secure.

- 1 : Quick connector
- 2 : Retainer
- A : Hard tube (or the equivalent)
- B : Connection (cross-section)
- C : Resin tube
- D : To under floor fuel line
- E : To fuel tank
- F : Tab
- G : Disconnection

- Ensure that connector and resin tube never contact any adjacent parts.

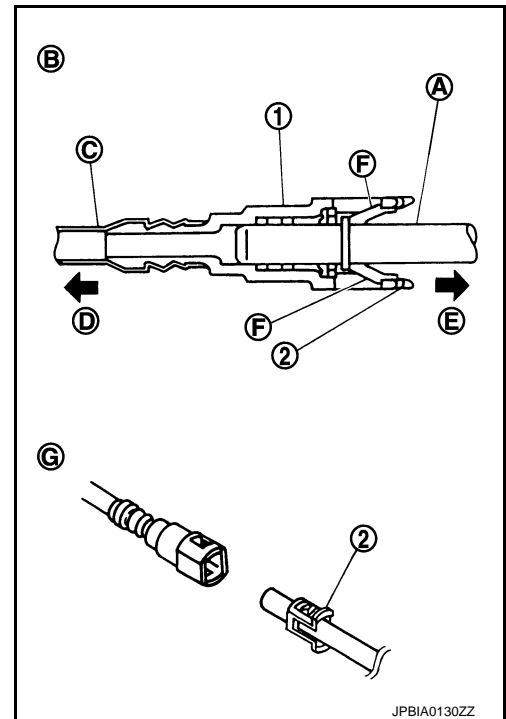

FUEL LEVEL SENSOR UNIT, FUEL FILTER AND FUEL PUMP ASSEMBLY

< REMOVAL AND INSTALLATION >

REMOVAL AND INSTALLATION

FUEL LEVEL SENSOR UNIT, FUEL FILTER AND FUEL PUMP ASSEMBLY

Exploded View

INFOID:000000007378404

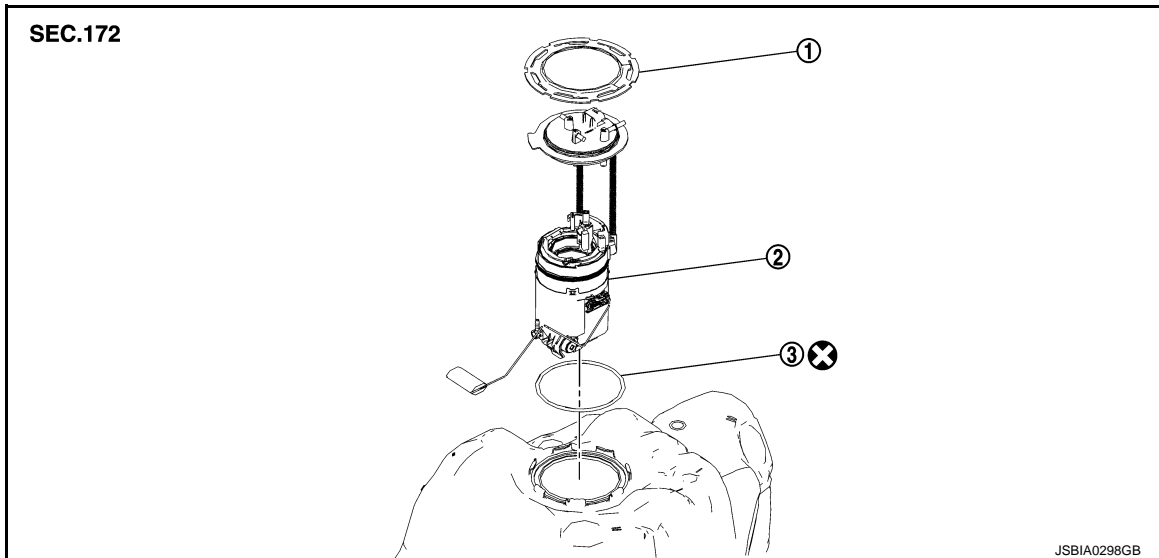

1. Lock ring
2. Fuel level sensor unit, fuel filter and fuel pump assembly
3. O-ring

Refer to [GI-4, "Components"](#) for symbols in the figure.

Removal and Installation

INFOID:000000007378405

WARNING:

Be sure to read "General Precautions" when working on the fuel system. Refer to [FL-2, "General Precautions"](#).

REMOVAL

1. Check fuel level on a level ground. If the fuel level is 7/8 of the fuel tank (full or nearly full), draw appropriate amount of fuel from the fuel tank.

Guideline : Draw approximately 20 liters from a full-tank condition.

- In the event of malfunction in fuel pump, insert a hose measuring 20mm (0.79 in) in diameter into the filler opening to draw approximately 20 liters fuel.

2. Release the fuel pressure from the fuel lines. Refer to the following table:

ENGINE	Reference page
VK56VD FOR USA AND CANADA	EC-150, "Work Procedure"
VK56VD FOR MEXICO	EC-697, "Work Procedure"

3. Open fuel filler lid.
4. Open filler cap and release the pressure inside fuel tank.
5. Tilt the second seat toward the front of the vehicle.

FUEL LEVEL SENSOR UNIT, FUEL FILTER AND FUEL PUMP ASSEMBLY

< REMOVAL AND INSTALLATION >

6. Peel off floor carpet, then remove inspection hole cover (1) by turning clips (2) clockwise by 90 degrees (b).

A : Direction mark

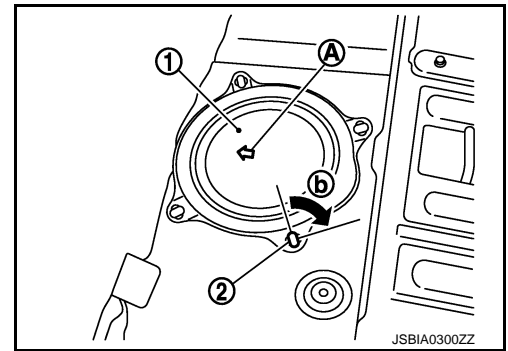

JSBIA0300ZZ

7. Disconnect harness connector (1) and all the fuel tube.

2 : Fuel feed tube

3 : Quick connector

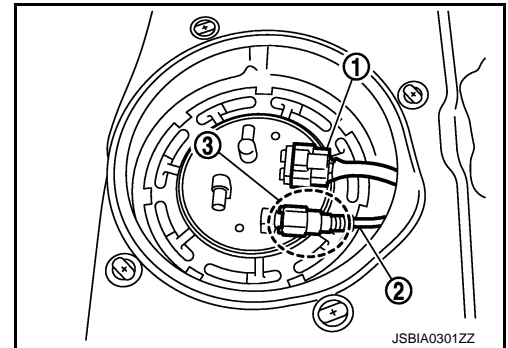

JSBIA0301ZZ

Disconnect quick connector as follows:

- Hold the sides of connector, push in tabs and pull out fuel feed tube.

A : Pull

B : Push in tabs

- If quick connector sticks to tube of main fuel level sensor unit, push and pull quick connector several times until they start to move. Then disconnect them by pulling.

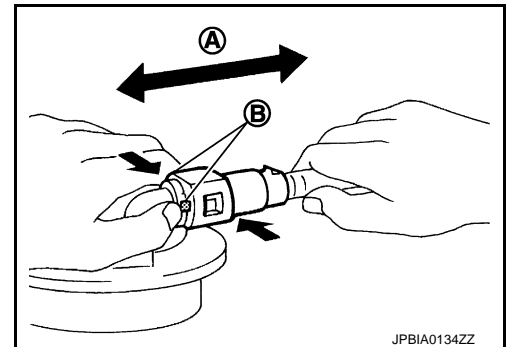

JPBIA0134ZZ

CAUTION:

FUEL LEVEL SENSOR UNIT, FUEL FILTER AND FUEL PUMP ASSEMBLY

< REMOVAL AND INSTALLATION >

- Quick connector (1) can be disconnected when the tabs (F) are completely depressed. Never twist it more than necessary.

B : Connection (Cross-section)
 D : To under floor fuel line
 E : To fuel tank
 G : Disconnection

- Never use any tools to disconnected quick connector.
- Keep resin tube (C) away from heat. Be especially careful when welding near the resin tube.
- Prevent acid liquid such as battery electrolyte, etc. from getting on resin tube.
- Never bend or twist resin tube during installation and disconnection.
- Never remove the remaining retainer (2) on hard tube (or the equivalent) (A) except when resin tube or retainer is replaced.
- When resin tube or hard tube (or the equivalent) is replaced, also replace retainer with new one.

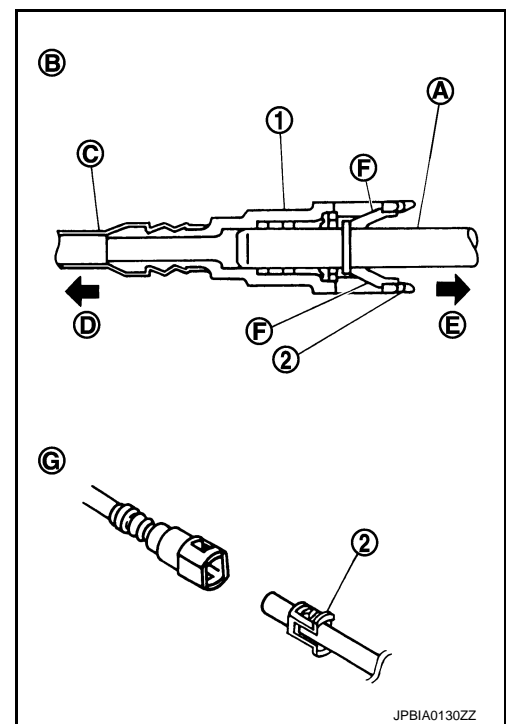

- To keep the connecting portion clean and to avoid damage and foreign materials, cover them completely with plastic bags (A) or something similar.

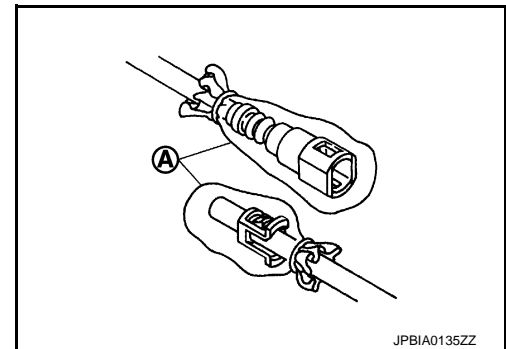

- Remove lock ring for fuel level sensor unit, fuel filter and fuel pump assembly with fuel tank lock ring wrench [SST: KV10119800/ KV10119801 (J-45722)] (A) by turning counter-clockwise.

NOTE:

The figure shows KV10119800.

- Remove fuel level sensor unit, fuel filter and fuel pump assembly.

CAUTION:

- Never bend float arm during removal.
- Avoid impacts such as falling when handling components.

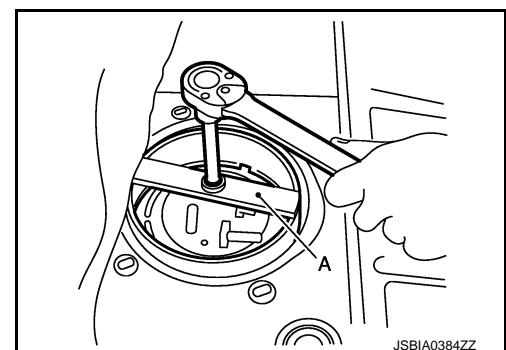

INSTALLATION

Note to the following, and install in the reverse order of removal.

CAUTION:

Do not reuse O-rings.

Quick Connector

- Connect quick connector as follows:

- Check the connection for damage or any foreign materials.
- Align the connector with the tube, then insert the connector straight into the tube until a click sound is heard.

FUEL LEVEL SENSOR UNIT, FUEL FILTER AND FUEL PUMP ASSEMBLY

< REMOVAL AND INSTALLATION >

3. After connecting, check that the connection is secure by following method.
 - Pull the tube and the connector to check they are securely connected.

A : Pull

- Visually confirm that the two retainer tabs are connected to the connector.

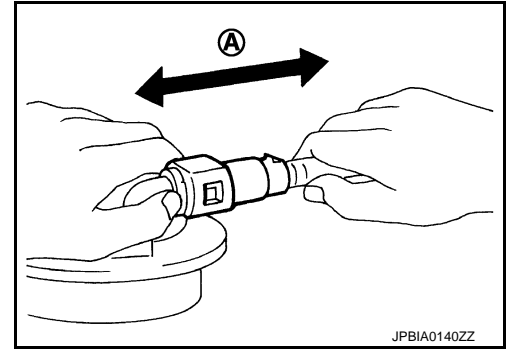

INFOID:000000007378406

Inspection

INSPECTION AFTER INSTALLATION

Use the following procedure to check for fuel leakage.

1. Turn ignition switch "ON" (with engine stopped), then check connections for leakage by applying fuel pressure to fuel piping.
2. Start engine and let it idle and check there are no fuel leakage at the fuel system connections.

FUEL TANK

< REMOVAL AND INSTALLATION >

FUEL TANK

Exploded View

INFOID:000000007378407

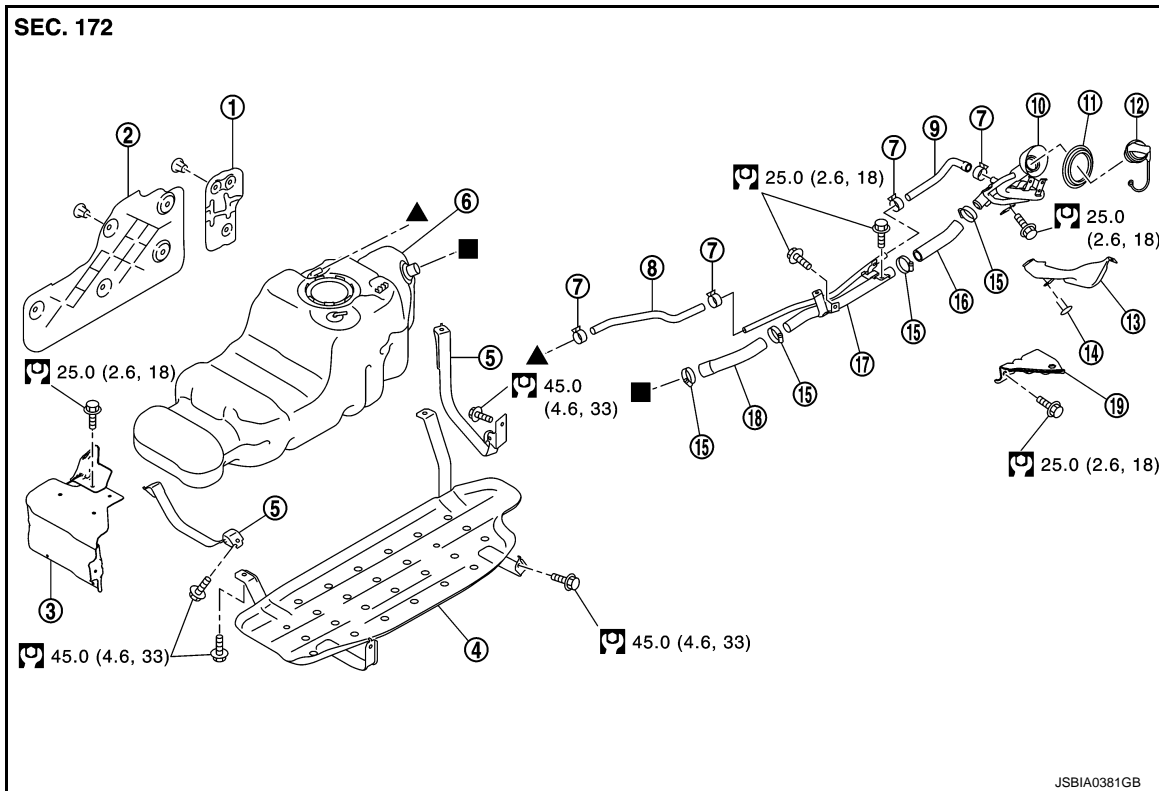

- | | | |
|--------------------------------|-----------------------------|------------------------------|
| 1. Fuel tank side protector | 2. Fuel tank side protector | 3. Fuel tank front protector |
| 4. Fuel tank protector | 5. Fuel tank mounting band | 6. Fuel tank |
| 7. Clamp | 8. Vent hose | 9. Vent hose |
| 10. Fuel filler tube | 11. Grommet | 12. Fuel filler cap |
| 13. Fuel filler tube protector | 14. Clip | 15. Clamp |
| 16. Fuel filler hose | 17. Fuel filler tube | 18. Fuel filler hose |
| 19. Fuel filler tube protector | | |

▲, ■ : Indicates that the part is connected at points with same symbol in actual vehicle.

Refer to [GI-4, "Components"](#) for symbols in the figure.

Removal and Installation

INFOID:000000007378408

WARNING:

Be sure to read "General Precautions" when working on the fuel system. Refer to [FL-2, "General Precautions"](#).

REMOVAL

CAUTION:

Perform work on level place.

1. Check fuel level on a level ground. If the fuel level is 7/8 of the fuel tank (full or nearly full), draw appropriate amount of fuel from the fuel tank.

Guideline : Draw approximately 20 liters from a full-tank condition.

- In the event of malfunction in fuel pump, insert a hose measuring 20mm (0.79 in) in diameter into the filler opening to draw approximately 20 liters fuel.

FUEL TANK

< REMOVAL AND INSTALLATION >

2. Perform steps 2 to 7 of "REMOVAL" in " FUEL LEVEL SENSOR UNIT, FUEL FILTER AND FUEL PUMP ASSEMBLY" on fuel level sensor unit, fuel filter and fuel pump assembly. Refer to [FL-5, "Removal and Installation"](#).
3. Remove LH rear wheel and tire.
4. Disconnect fuel filler hose, vent hose and EVAP hose at fuel tank side.
5. Remove fuel tank protector.
6. Remove the fuel tank mounting band bolts while supporting the fuel tank with a suitable lift jack.

CAUTION:

Support the position that fuel tank mounting bands never engage.

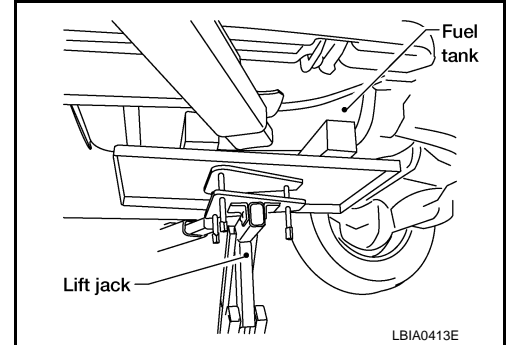

7. Supporting with hands, descend suitable jack carefully, and remove fuel tank.

CAUTION:

- Check that all connection points have been disconnected.
- Confirm there is no interference with vehicle.

Inspection

INFOID:000000007378409

INSPECTION AFTER INSTALLATION

Use the following procedure to check for fuel leakage.

1. Turn ignition switch "ON" (with engine stopped), and check connections for leakage by applying fuel pressure to fuel piping.
 2. Start engine and rev it up and check there are no fuel leakage at the fuel system tube and hose connections.
- After removing/installing rear suspension assembly, check to adjust wheel alignment. Refer to [RSU-6, "Inspection"](#).

EVAP CANISTER

< REMOVAL AND INSTALLATION >

EVAP CANISTER

Exploded View

INFOID:000000007378410

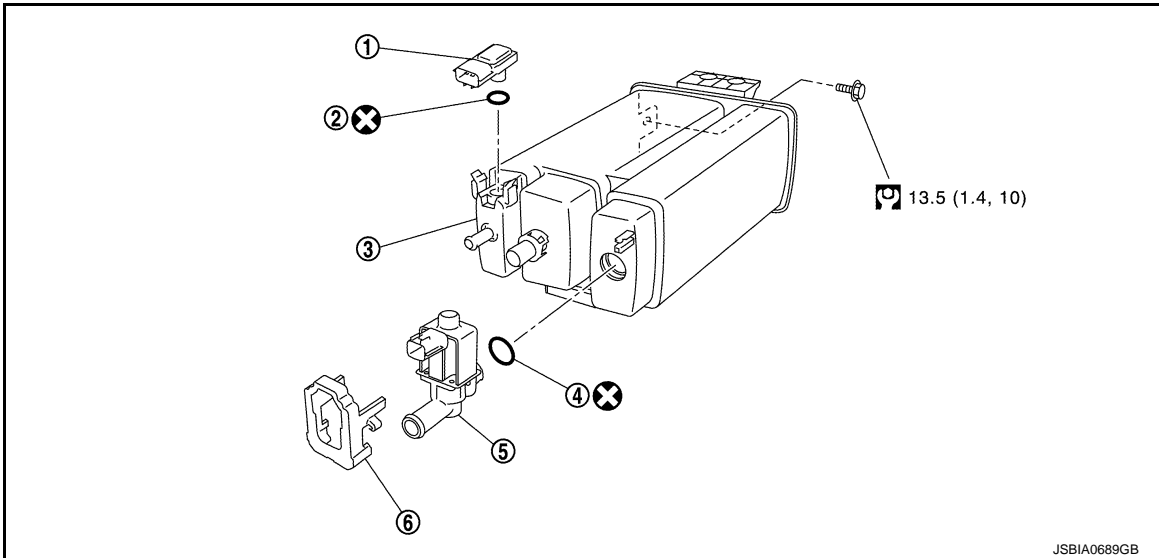

- | | | |
|--|-------------------------------------|---|
| 1. EVAP control system pressure sensor | 2. O-ring | 3. EVAP canister |
| 4. O-ring | 5. EVAP canister vent control valve | 6. EVAP canister vent control valve cover |

Refer to [GI-4, "Components"](#) for symbols not described on the above.

Hydraulic Layout

INFOID:000000007378411

EVAPORATIVE EMISSION LINE DRAWING

A
FL
C
D
E
F
G
H
I
J
K
L
M
N
O
P

EVAP CANISTER

< REMOVAL AND INSTALLATION >

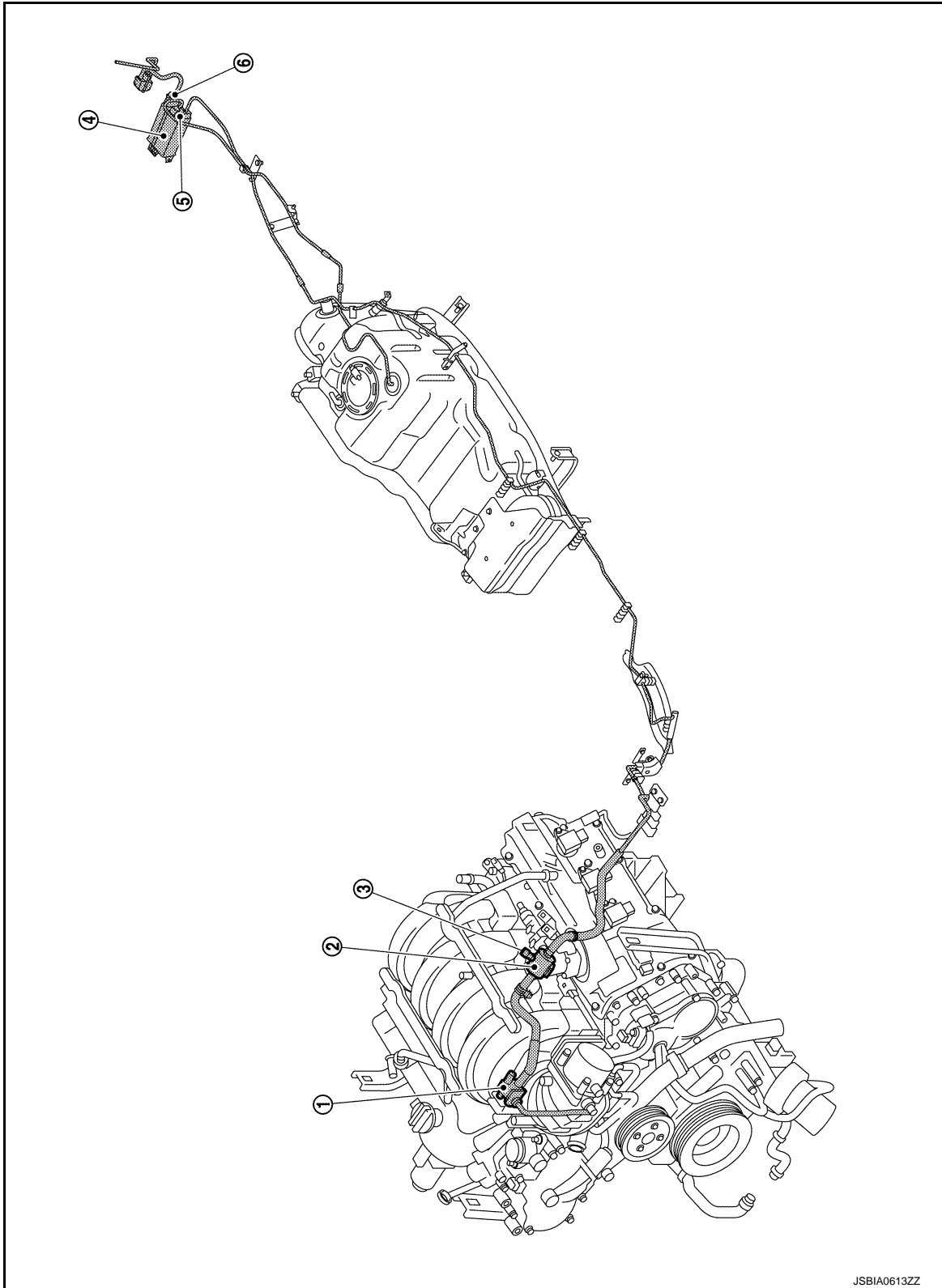

- | | | |
|--|--|-------------------------------------|
| 1. EVAP canister purge volume control solenoid valve | 2. EVAP purge resonator | 3. EVAP service port |
| 4. EVAP canister | 5. EVAP control system pressure sensor | 6. EVAP canister vent control valve |

NOTE:

Do not use soapy water or any type of solvent while installing vacuum hose or purge hoses.

EVAP CANISTER

< REMOVAL AND INSTALLATION >

Removal and Installation

INFOID:000000007378412

REMOVAL

1. Remove the spare tire.
2. Disconnect harness connectors and hoses.
3. Remove EVAP canister fixing bolt.
4. Remove EVAP canister.

NOTE:

The EVAP canister vent control valve and EVAP control system pressure sensor can be removed without removing the EVAP canister.

INSTALLATION

Install in the reverse order of removal.

NOTE:

Tighten EVAP canister fixing bolt to the specified torque.

Disassembly and Assembly

INFOID:000000007378413

DISASSEMBLY

1. Disengage the pawl and turn EVAP canister vent control valve counterclockwise.
 - Lock (A)
 - Unlock (B)
2. Remove the EVAP canister vent control valve.

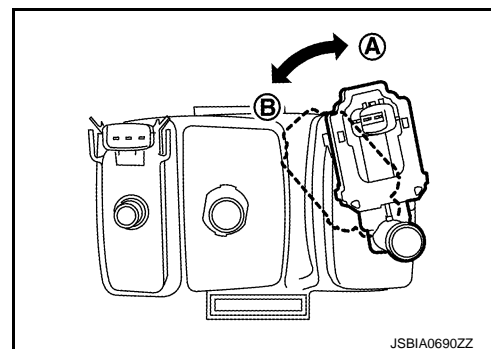

ASSEMBLY

Assemble in the reverse order of disassembly.

CAUTION:

Do not reuse O-rings.

Inspection

INFOID:000000007378414

Check EVAP canister as per the following:

1. Block port (B).
2. Blow air into port (A) and check that it flows freely out of port (C).
3. Release blocked port (B).
4. Apply vacuum pressure to port (B) and check that vacuum pressure exists at the ports (A) and (C).
5. Block port (A) and (B).
6. Apply pressure to port (C) and check that there is no leakage.

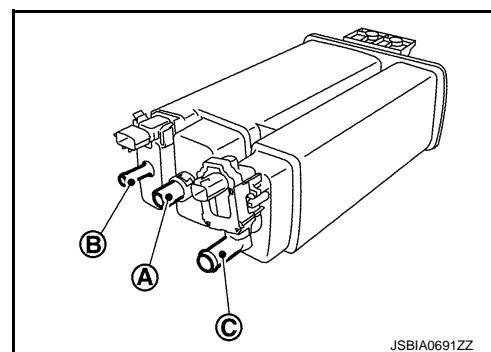

SERVICE DATA AND SPECIFICATIONS (SDS)

< SERVICE DATA AND SPECIFICATIONS (SDS)

SERVICE DATA AND SPECIFICATIONS (SDS)

SERVICE DATA AND SPECIFICATIONS (SDS)

Fuel Tank

INFOID:000000007378415

Standard and Limit

Fuel tank capacity	Approx. 98.4 ℓ (26 US gal, 21-5/8 Imp gal)
Fuel recommendation	Refer to GI-33, "Fuel"