

SECTION **CHG**
CHARGING SYSTEM

A
B
C
D
E
F
G
H
I
J
K
L

CONTENTS

PRECAUTION	3	Work Flow(Without EXP-800 NI or GR8-1200 NI)....	13
PRECAUTIONS	3	CHARGING SYSTEM PRELIMINARY INSPECTION	16
Precaution for Supplemental Restraint System (SRS) "AIR BAG" and "SEAT BELT PRE-TENSIONER"	3	Inspection Procedure	16
Precaution for Power Generation Voltage Variable Control System	3	POWER GENERATION VOLTAGE VARIABLE CONTROL SYSTEM OPERATION INSPECTION	17
PREPARATION	4	Inspection Procedure	17
PREPARATION	4	DTC/CIRCUIT DIAGNOSIS	19
Special Service Tools	4	B TERMINAL CIRCUIT	19
Commercial Service Tools	4	Description	19
SYSTEM DESCRIPTION	5	Diagnosis Procedure	19
COMPONENT PARTS	5	L TERMINAL CIRCUIT (OPEN)	20
Component Parts Location	5	Description	20
Component Description	5	Diagnosis Procedure	20
SYSTEM	6	L TERMINAL CIRCUIT (SHORT)	22
CHARGING SYSTEM	6	Description	22
CHARGING SYSTEM : System Diagram	6	Diagnosis Procedure	22
CHARGING SYSTEM : System Description	6	S TERMINAL CIRCUIT	23
POWER GENERATION VOLTAGE VARIABLE CONTROL SYSTEM	6	Description	23
POWER GENERATION VOLTAGE VARIABLE CONTROL SYSTEM : System Diagram	6	Diagnosis Procedure	23
POWER GENERATION VOLTAGE VARIABLE CONTROL SYSTEM : System Description	6	SYMPTOM DIAGNOSIS	24
WIRING DIAGRAM	8	CHARGING SYSTEM	24
CHARGING SYSTEM	8	Symptom Table	24
Wiring Diagram	8	REMOVAL AND INSTALLATION	25
BASIC INSPECTION	9	ALTERNATOR	25
DIAGNOSIS AND REPAIR WORKFLOW	9	Exploded View	25
Work Flow(With EXP-800 NI or GR8-1200 NI)	9	Removal and Installation	26
		Inspection	28
		SERVICE DATA AND SPECIFICATIONS (SDS)	29

CHG

N
O
P

SERVICE DATA AND SPECIFICATIONS

(SDS) 29

Alternator 29

PRECAUTIONS

< PRECAUTION >

PRECAUTION

PRECAUTIONS

Precaution for Supplemental Restraint System (SRS) "AIR BAG" and "SEAT BELT PRE-TENSIONER"

INFOID:000000009012357

The Supplemental Restraint System such as "AIR BAG" and "SEAT BELT PRE-TENSIONER", used along with a front seat belt, helps to reduce the risk or severity of injury to the driver and front passenger for certain types of collision. Information necessary to service the system safely is included in the "SRS AIR BAG" and "SEAT BELT" of this Service Manual.

WARNING:

Always observe the following items for preventing accidental activation.

- To avoid rendering the SRS inoperative, which could increase the risk of personal injury or death in the event of a collision that would result in air bag inflation, all maintenance must be performed by an authorized NISSAN/INFINITI dealer.
- Improper maintenance, including incorrect removal and installation of the SRS, can lead to personal injury caused by unintentional activation of the system. For removal of Spiral Cable and Air Bag Module, see "SRS AIR BAG".
- Never use electrical test equipment on any circuit related to the SRS unless instructed to in this Service Manual. SRS wiring harnesses can be identified by yellow and/or orange harnesses or harness connectors.

PRECAUTIONS WHEN USING POWER TOOLS (AIR OR ELECTRIC) AND HAMMERS

WARNING:

Always observe the following items for preventing accidental activation.

- When working near the Air Bag Diagnosis Sensor Unit or other Air Bag System sensors with the ignition ON or engine running, never use air or electric power tools or strike near the sensor(s) with a hammer. Heavy vibration could activate the sensor(s) and deploy the air bag(s), possibly causing serious injury.
- When using air or electric power tools or hammers, always switch the ignition OFF, disconnect the battery, and wait at least 3 minutes before performing any service.

Precaution for Power Generation Voltage Variable Control System

INFOID:000000009012358

CAUTION:

For this model, the battery current sensor that is installed to the battery cable at the negative terminal measures the charging/discharging current of the battery, and performs various controls. If the electrical component or the ground wire is connected directly to the battery terminal, the current other than that being measured with the battery current sensor is charging to or discharging from the battery. This condition causes the malfunction of the control, and then the battery discharge may occur. Do not connect the electrical component or the ground wire directly to the battery terminal.

A
B
C
D
E
F
G
H
I
J
K
L
N
O
P

CHG

PREPARATION

< PREPARATION >

PREPARATION

PREPARATION

Special Service Tools

INFOID:000000009012359

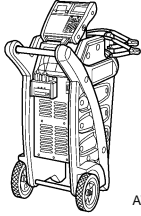
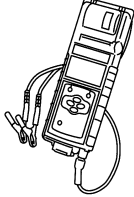
Tool number (Kent-Moore No.) Tool name	Description
<p>— (—) Model GR8-1200 NI Multitasking battery and electrical diagnostic station</p>  <p style="text-align: right; font-size: small;">AWIA1239ZZ</p>	<p>Tests batteries, starting and charging systems and charges batteries. For operating instructions, refer to diagnostic station instruction manual.</p>
<p>— (—) Model EXP-800 NI Battery and electrical diagnostic analyzer</p>  <p style="text-align: right; font-size: small;">JSMIA0806ZZ</p>	<p>Tests batteries and charging systems. For operating instructions, refer to diagnostic analyzer instruction manual.</p>

Commercial Service Tools

INFOID:000000009012360

Tool name	Description
<p>Power tool</p>  <p style="text-align: right; font-size: small;">PIIB1407E</p>	<p>Loosening bolts, nuts and screws</p>

COMPONENT PARTS

< SYSTEM DESCRIPTION >

SYSTEM DESCRIPTION

COMPONENT PARTS

Component Parts Location

INFOID:000000009012361

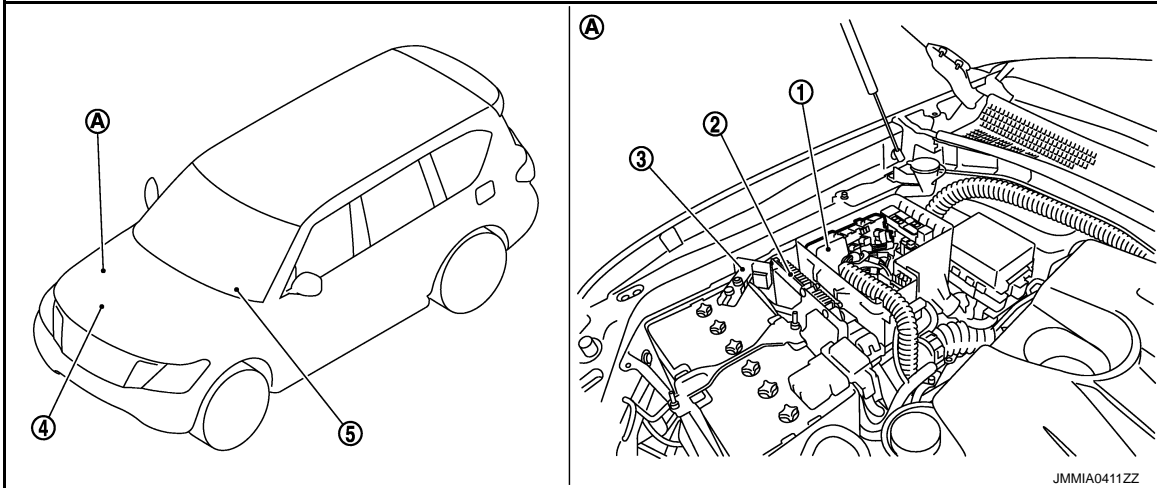

- | | | |
|---------------------|--|---------------------------|
| 1. IPDM E/R | 2. ECM | 3. Battery current sensor |
| 4. Alternator | 5. Combination meter (charge warning lamp) | |
| A. Engine room (RH) | | |

Component Description

INFOID:000000009012362

Component part	Description
Alternator (IC voltage regulator)	IC voltage regulator controls the power generation voltage by the target power generation voltage based on the received power generation command signal. When there is no power generation command signal, the alternator performs the normal power generation according to the characteristic of the IC voltage regulator.
Battery current sensor	Battery current sensor is installed to the battery cable at the negative terminal, and it detects the charging/discharging current of the battery and sends the voltage signal to ECM according to the current value.
Combination meter (Charge warning lamp)	The IC voltage regulator warning function activates to illuminate the charge warning lamp, if any of the following symptoms occur while alternator is operating: <ul style="list-style-type: none"> Excessive voltage is produced. No voltage is produced.
ECM	Battery current sensor detects the charging/discharging current of the battery. ECM judges the battery condition based on this signal. ECM judges whether to perform the power generation voltage variable control according to the battery condition. When performing the power generation voltage variable control, ECM calculates the target power generation voltage according to the battery condition and sends the calculated value as the power generation command value to IPDM E/R.
IPDM E/R	IPDM E/R converts the received power generation command value into the power generation command signal (PWM signal) and sends it to the IC voltage regulator.

SYSTEM

< SYSTEM DESCRIPTION >

SYSTEM

CHARGING SYSTEM

CHARGING SYSTEM : System Diagram

INFOID:000000009012363

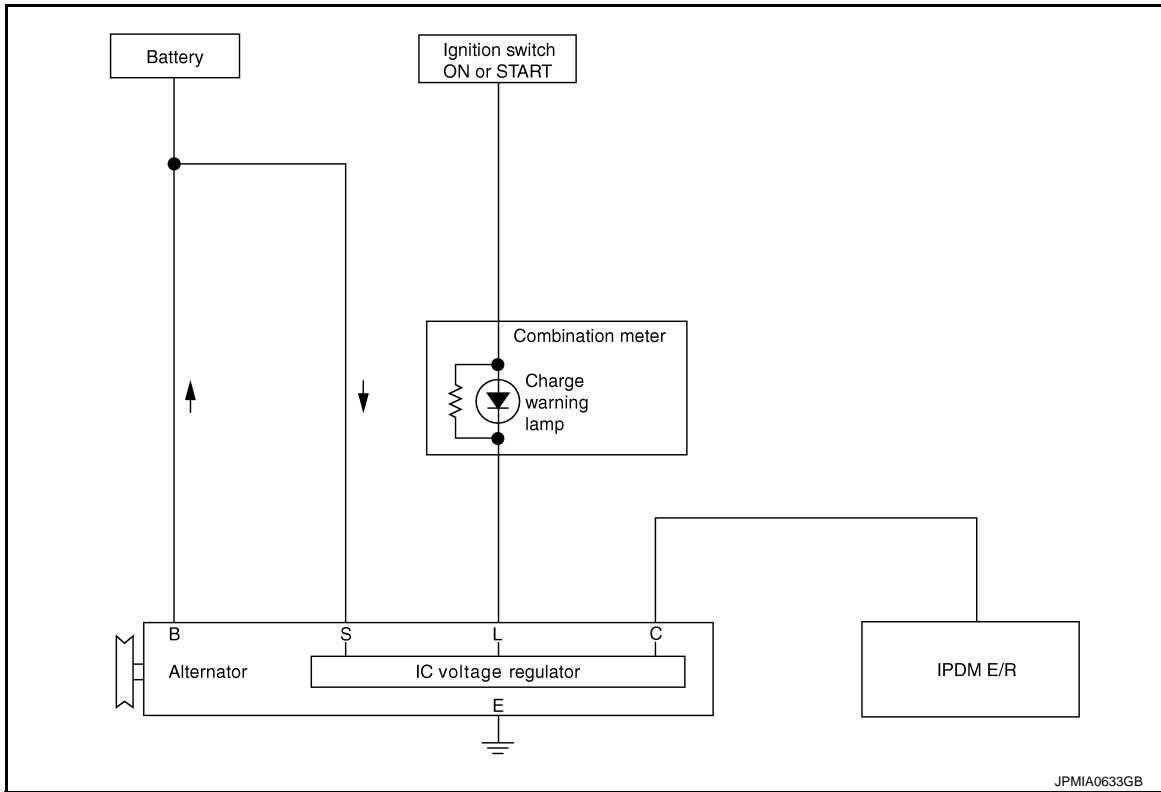

JPMIA0633GB

CHARGING SYSTEM : System Description

INFOID:000000009012364

The alternator provides DC voltage to operate the vehicle's electrical system and to keep the battery charged. The voltage output is controlled by the IC voltage regulator.

POWER GENERATION VOLTAGE VARIABLE CONTROL SYSTEM

POWER GENERATION VOLTAGE VARIABLE CONTROL SYSTEM : System Diagram

INFOID:000000009012365

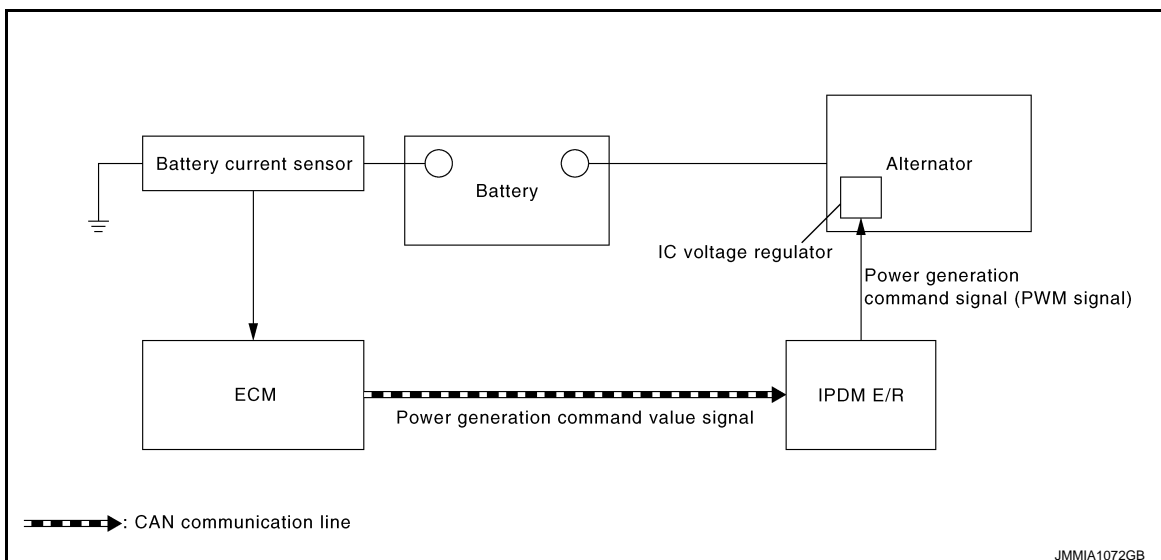

JMMIA1072GB

POWER GENERATION VOLTAGE VARIABLE CONTROL SYSTEM : System De-

SYSTEM

< SYSTEM DESCRIPTION >

scription

INFOID:000000009012366

By performing the power generation voltage variable control, the engine load due to the power generation of the alternator is reduced and fuel consumption is decreased.

NOTE:

When any malfunction is detected in the power generation voltage variable control system, the power generation is performed according to the characteristic of the IC voltage regulator of the alternator.

A
B
C
D
E
F
G
H
I
J
K
L

CHG

N
O
P

CHARGING SYSTEM

< WIRING DIAGRAM >

WIRING DIAGRAM

CHARGING SYSTEM

Wiring Diagram

INFOID:000000009012367

For connector terminal arrangements, harness layouts, and alphabets in a  (option abbreviation; if not described in wiring diagram), refer to [GI-12. "Connector Information"](#).

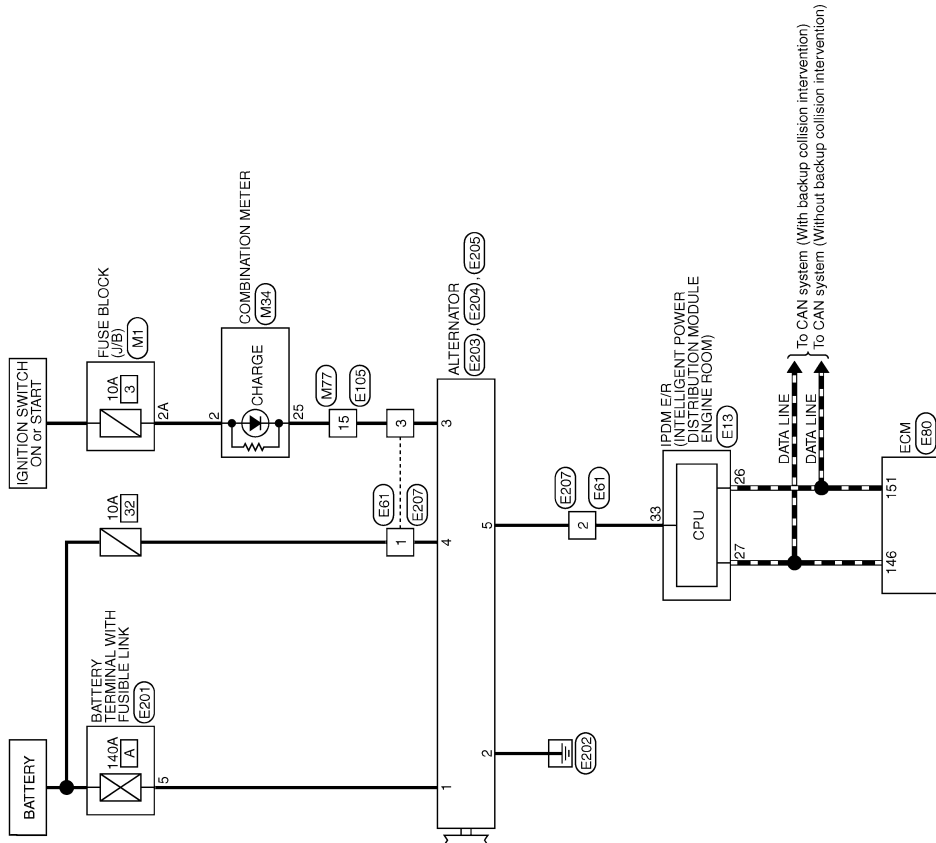

CHARGING SYSTEM

2013/01/30

JRMWD7275GB

DIAGNOSIS AND REPAIR WORKFLOW

< BASIC INSPECTION >

BASIC INSPECTION

DIAGNOSIS AND REPAIR WORKFLOW

Work Flow(With EXP-800 NI or GR8-1200 NI)

INFOID:000000009012368

CHARGING SYSTEM DIAGNOSIS WITH EXP-800 NI OR GR8-1200 NI

To test the charging system, use the following special service tools:

- EXP-800 NI Battery and electrical diagnostic analyzer
- GR8-1200 NI Multitasking battery and electrical diagnostic station

NOTE:

Refer to the applicable Instruction Manual for proper charging system diagnosis procedures.

A
B
C
D
E
F
G
H
I
J
K
L
N
O
P

CHG

DIAGNOSIS AND REPAIR WORKFLOW

< BASIC INSPECTION >

OVERALL SEQUENCE

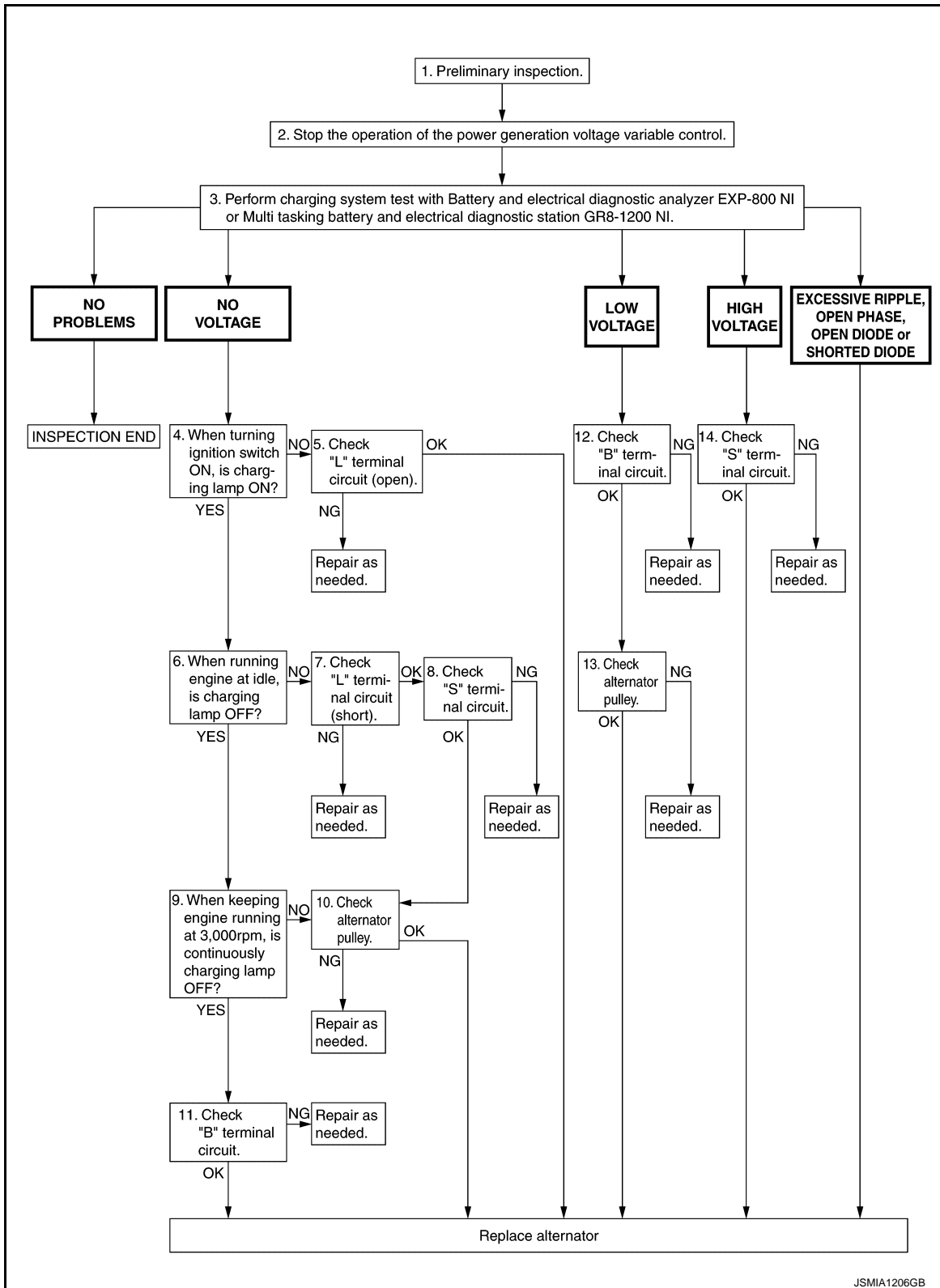

DETAILED FLOW

NOTE:

To ensure a complete and thorough diagnosis, the battery, starter and alternator test segments must be done as a set from start to finish.

1. PRELIMINARY INSPECTION

Perform the preliminary inspection. Refer to [CHG-16, "Inspection Procedure"](#).

DIAGNOSIS AND REPAIR WORKFLOW

< BASIC INSPECTION >

>> GO TO 2.

2. STOP POWER GENERATION VOLTAGE VARIABLE CONTROL SYSTEM

Stop the operation of the power generation voltage variable control in either of the following procedures.

- After selecting “ENGINE” of “SELECT SYSTEM” using CONSULT, set the DUTY value of “ALTERNATOR DUTY” to 0 % by selecting “ALTERNATOR DUTY” of “Active Test”. Continue “Active Test” until the end of inspection. (When the DUTY value is 0 or 100 %, the normal power generation is performed according to the characteristic of the IC voltage regulator of the alternator.)
- Turn the ignition switch OFF, and disconnect the battery current sensor connector. [However, DTC (P1550 - P1554) of the engine might remain. After finishing the inspection, connect the battery current sensor connector and erase the self-diagnosis results history of the engine using CONSULT.]

>> GO TO 3.

3. DIAGNOSIS WITH EXP-800 NI OR GR8-1200 NI

Perform the charging system test using Multitasking battery and electrical diagnostic station GR8-1200 NI or Battery and electrical diagnostic analyzer EXP-800 NI. Refer to the applicable Instruction Manual for proper testing procedures.

Test result

NO PROBLEMS>>Charging system is normal and will also show “DIODE RIPPLE” test result.

NO VOLTAGE>>GO TO 4.

LOW VOLTAGE>>GO TO 12.

HIGH VOLTAGE>>GO TO 14.

EXCESSIVE RIPPLE, OPEN PHASE, OPEN DIODE or SHORTED DIODE>>Replace the alternator. Perform “DIODE RIPPLE” test again using Multitasking battery and electrical diagnostic station GR8-1200 NI or Battery and electrical diagnostic analyzer EXP-800 NI to confirm repair.

4. INSPECTION WITH CHARGE WARNING LAMP (IGNITION SWITCH IS ON)

Turn the ignition switch ON.

Does the charge warning lamp illuminate?

YES >> GO TO 6.

NO >> GO TO 5.

5. “L” TERMINAL CIRCUIT (OPEN) INSPECTION

Check “L” terminal circuit (open). Refer to [CHG-20, "Diagnosis Procedure"](#).

Is the “L” terminal circuit normal?

YES >> Replace alternator.

NO >> Repair as needed.

6. INSPECTION WITH CHARGE WARNING LAMP (IDLING)

Start the engine and run it at idle.

Does the charge warning lamp turn OFF?

YES >> GO TO 9.

NO >> GO TO 7.

7. “L” TERMINAL CIRCUIT (SHORT) INSPECTION

Check “L” terminal circuit (short). Refer to [CHG-22, "Diagnosis Procedure"](#).

Is the “L” terminal circuit normal?

YES >> GO TO 8.

NO >> Repair as needed.

8. “S” TERMINAL CIRCUIT INSPECTION

Check “S” terminal circuit. Refer to [CHG-23, "Diagnosis Procedure"](#).

Is the “S” terminal circuit normal?

YES >> GO TO 10.

NO >> Repair as needed.

A

B

C

D

E

F

G

H

I

J

K

L

CHG

N

O

P

DIAGNOSIS AND REPAIR WORKFLOW

< BASIC INSPECTION >

9. INSPECTION WITH CHARGE WARNING LAMP (ENGINE AT 3,000 RPM)

Increase and maintain the engine speed at 3,000 rpm.

Does the charge warning lamp remain off?

YES >> GO TO 11.

NO >> GO TO 10.

10. INSPECTION OF ALTERNATOR PULLEY

Check alternator pulley. Refer to [CHG-28, "Inspection"](#).

Is alternator pulley normal?

YES >> Replace alternator.

NO >> Repair as needed.

11. "B" TERMINAL CIRCUIT INSPECTION

Check "B" terminal circuit. Refer to [CHG-19, "Diagnosis Procedure"](#).

Is "B" terminal circuit normal?

YES >> Replace alternator.

NO >> Repair as needed.

12. "B" TERMINAL CIRCUIT INSPECTION

Check "B" terminal circuit. Refer to [CHG-19, "Diagnosis Procedure"](#).

Is "B" terminal circuit normal?

YES >> GO TO 13.

NO >> Repair as needed.

13. INSPECTION OF ALTERNATOR PULLEY

Check alternator pulley. Refer to [CHG-28, "Inspection"](#).

Is alternator pulley normal?

YES >> Replace alternator.

NO >> Repair as needed.

14. "S" TERMINAL CIRCUIT INSPECTION

Check "S" terminal circuit. Refer to [CHG-23, "Diagnosis Procedure"](#).

Is the "S" terminal circuit normal?

YES >> Replace alternator.

NO >> Repair as needed.

DIAGNOSIS AND REPAIR WORKFLOW

< BASIC INSPECTION >

Work Flow(Without EXP-800 NI or GR8-1200 NI)

INFOID:000000009012369

OVERALL SEQUENCE

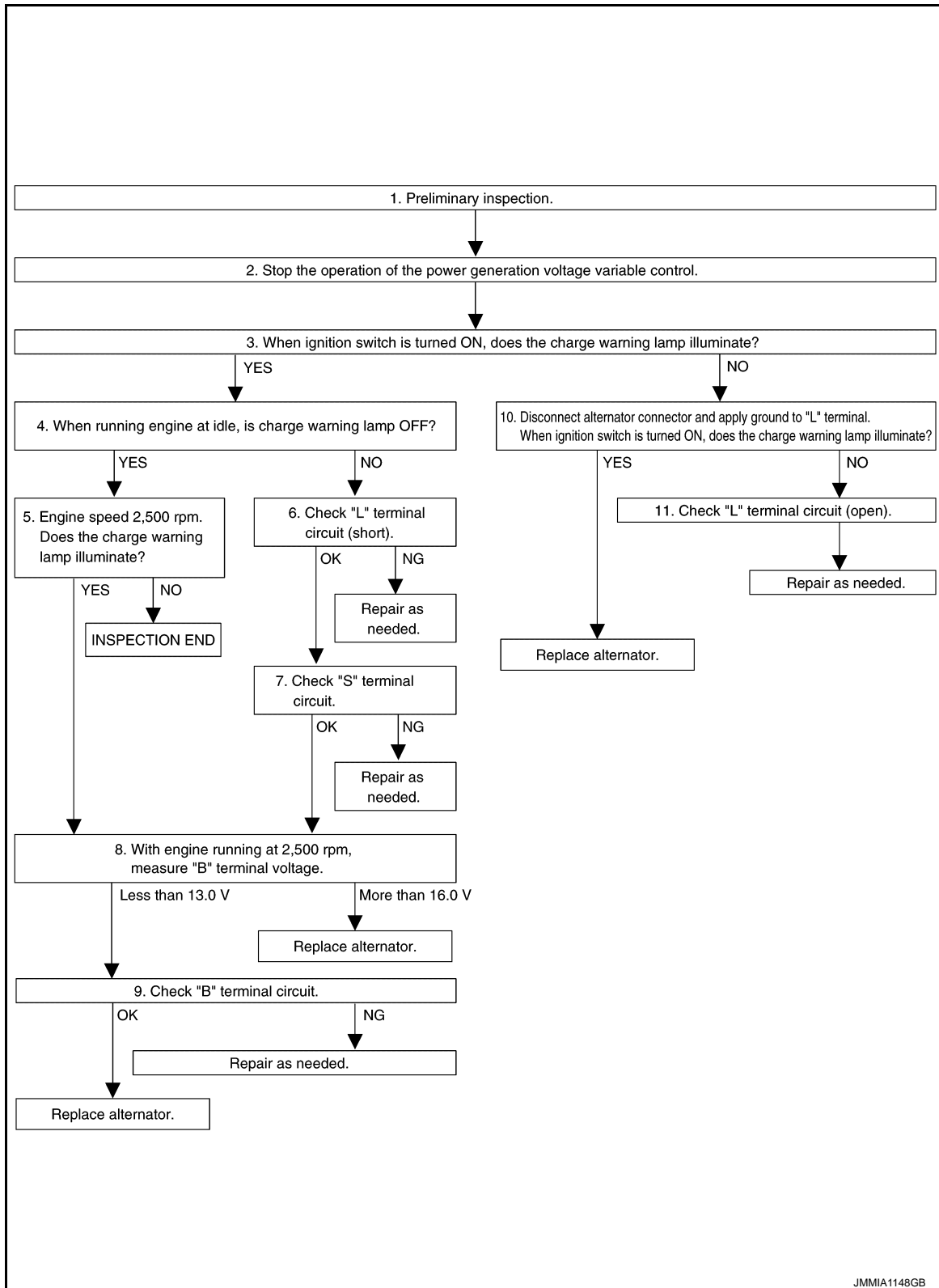

DETAILED FLOW

1. PRELIMINARY INSPECTION

Perform the preliminary inspection. Refer to [CHG-16, "Inspection Procedure"](#).

DIAGNOSIS AND REPAIR WORKFLOW

< BASIC INSPECTION >

>> GO TO 2.

2. STOP POWER GENERATION VOLTAGE VARIABLE CONTROL SYSTEM

Stop the operation of the power generation voltage variable control in either of the following procedures.

- After selecting "ENGINE" of "SELECT SYSTEM" using CONSULT, set the DUTY value of "ALTERNATOR DUTY" to 0 % by selecting "ALTERNATOR DUTY" of "Active Test". Continue "Active Test" until the end of inspection. (When the DUTY value is 0 or 100 %, the normal power generation is performed according to the characteristic of the IC voltage regulator of the alternator.)
- Turn the ignition switch OFF, and disconnect the battery current sensor connector. [However, DTC (P1550 - P1554) of the engine might remain. After finishing the inspection, connect the battery current sensor connector and erase the self-diagnosis results history of the engine using CONSULT.]

>> GO TO 3.

3. INSPECTION WITH CHARGE WARNING LAMP (IGNITION SWITCH IS TURNED ON)

When ignition switch is turned ON

Does the charge warning lamp illuminate?

YES >> GO TO 4.

NO >> GO TO 10.

4. INSPECTION WITH CHARGE WARNING LAMP (IDLING)

Start the engine and run it at idle.

Does the charge warning lamp turn OFF?

YES >> GO TO 5.

NO >> GO TO 6.

5. INSPECTION WITH CHARGE WARNING LAMP (ENGINE AT 2,500 RPM)

Increase and maintain the engine speed at 2,500 rpm.

Does the charge warning lamp illuminate?

YES >> GO TO 8.

NO >> INSPECTION END

6. "L" TERMINAL CIRCUIT (SHORT) INSPECTION

Check "L" terminal circuit (short). Refer to [CHG-22, "Diagnosis Procedure"](#).

Is the inspection result normal?

YES >> GO TO 7.

NO >> Repair as needed.

7. "S" TERMINAL CIRCUIT INSPECTION

Check "S" terminal circuit. Refer to [CHG-23, "Diagnosis Procedure"](#).

Is the inspection result normal?

YES >> GO TO 8.

NO >> Repair as needed.

8. MEASURE "B" TERMINAL VOLTAGE

Start engine. With engine running at 2,500 rpm, measure "B" terminal voltage.

What voltage does the measurement result show?

Less than 13.0 V >> GO TO 9.

More than 16.0 V >> Replace alternator. Refer to [CHG-26, "Removal and Installation"](#).

9. "B" TERMINAL CIRCUIT INSPECTION

Check "B" terminal circuit. Refer to [CHG-19, "Diagnosis Procedure"](#).

Is the inspection result normal?

YES >> Replace alternator. Refer to [CHG-26, "Removal and Installation"](#).

NO >> Repair as needed.

10. INSPECTION WITH CHARGE WARNING LAMP (IGNITION SWITCH IS ON)

DIAGNOSIS AND REPAIR WORKFLOW

< BASIC INSPECTION >

1. Disconnect alternator connector and apply ground to "L" terminal.
2. Turn the ignition switch ON.

Does the charge warning lamp illuminate?

YES >> Replace alternator. Refer to [CHG-26. "Removal and Installation"](#).

NO >> GO TO 11.

11. CHECK "L" TERMINAL CIRCUIT (OPEN)

Check "L" terminal circuit (open). Refer to [CHG-20. "Diagnosis Procedure"](#).

>> Repair as needed.

A

B

C

D

E

F

G

H

I

J

K

L

CHG

N

O

P

CHARGING SYSTEM PRELIMINARY INSPECTION

< BASIC INSPECTION >

CHARGING SYSTEM PRELIMINARY INSPECTION

Inspection Procedure

INFOID:000000009012370

1. CHECK BATTERY TERMINALS CONNECTION

Check if battery terminals are clean and tight.

Is the inspection result normal?

YES >> GO TO 2.

NO >> Repair battery terminals connection.

2. CHECK FUSE

Check for blown fuse and fusible link.

Unit	Power source (Power supply terminals)	Fuse No.
Alternator	Battery ("S" terminal)	32
Combination meter	Ignition switch ON ("L" terminal)	3

Is the inspection result normal?

YES >> GO TO 3.

NO >> Replace the blown fuse after repairing the applicable circuit.

3. CHECK "E" TERMINAL CONNECTION

Check if "E" terminal (alternator ground harness) is clean and tight.

Is the inspection result normal?

YES >> GO TO 4.

NO >> Repair "E" terminal connection.

4. CHECK DRIVE BELT TENSION

Check drive belt tension. Refer to [EM-20, "Checking"](#).

Is the inspection result normal?

YES >> INSPECTION END

NO >> Repair as needed.

POWER GENERATION VOLTAGE VARIABLE CONTROL SYSTEM OPERATION INSPECTION

< BASIC INSPECTION >

POWER GENERATION VOLTAGE VARIABLE CONTROL SYSTEM OPERATION INSPECTION

Inspection Procedure

INFOID:000000009012371

CAUTION:

When performing this inspection, always use a charged battery that has completed the battery inspection. (When the charging rate of the battery is low, the response speed of the voltage change will become slow. This can cause an incorrect inspection.)

1. CHECK ECM (CONSULT)

Perform ECM self-diagnosis with CONSULT. Refer to [EC-71, "CONSULT Function"](#).

Self-diagnostic results content

No malfunction detected>> GO TO 2.

Malfunction detected>> Check applicable parts, and repair or replace corresponding parts.

2. CHECK OPERATION OF POWER GENERATION VOLTAGE VARIABLE CONTROL SYSTEM

1. Connect CONSULT and start the engine.
2. shift the selector lever to "P" or "N" position and turn off all of the electric loads and A/C, etc.
3. Select "ALTERNATOR DUTY" at "Active Test" of "ENGINE", and then check the value of "BATTERY VOLT" monitor when DUTY value of "ALTERNATOR DUTY" is set to 40.0 %.

"BATTERY VOLT"

2 seconds after setting the DUTY value of "ALTERNATOR DUTY" to 40.0 % : 12 - 13.6 V

4. Check the value of "BATTERY VOLT" monitor when DUTY value of "ALTERNATOR DUTY" is set to 80.0%.

"BATTERY VOLT"

20 seconds after setting the DUTY value of "ALTERNATOR DUTY" to 80.0 % : +0.5 V or more against the value of "BATTERY VOLT" monitor when DUTY value is 40.0 %

Is the measurement value within the specification?

YES >> INSPECTION END

NO >> GO TO 3.

3. CHECK IPDM E/R (CONSULT)

Perform IPDM E/R self-diagnosis with CONSULT. Refer to [PCS-12, "CONSULT Function \(IPDM E/R\)"](#).

Self-diagnostic results content

No malfunction detected>> GO TO 4.

Malfunction detected>> Check applicable parts, and repair or replace corresponding parts.

4. CHECK HARNESS BETWEEN ALTERNATOR AND IPDM E/R

1. Turn ignition switch OFF.
2. Disconnect alternator harness connector and IPDM E/R harness connector.
3. Check continuity between alternator harness connector and IPDM E/R harness connector.

Alternator		IPDM E/R		Continuity
Connector	Terminal	Connector	Terminal	
E205	5	E13	33	Existed

4. Check continuity between alternator harness connector and ground.

POWER GENERATION VOLTAGE VARIABLE CONTROL SYSTEM OPERATION INSPECTION

< BASIC INSPECTION >

Alternator		Ground	Continuity
Connector	Terminal		
E205	5		Not existed

Is the inspection result normal?

YES >> Replace IPDM E/R.

NO >> Repair harness or connector between IPDM E/R and alternator.

B TERMINAL CIRCUIT

< DTC/CIRCUIT DIAGNOSIS >

DTC/CIRCUIT DIAGNOSIS

B TERMINAL CIRCUIT

Description

INFOID:000000009012372

"B" terminal circuit supplies power to charge the battery and to operate the vehicle's electrical system.

Diagnosis Procedure

INFOID:000000009012373

1. CHECK "B" TERMINAL CONNECTION

1. Turn ignition switch OFF.
2. Check that "B" terminal is clean and tight.

Is the inspection result normal?

YES >> GO TO 2.

NO >> Repair "B" terminal connection. Confirm repair by performing complete Charging system test using EXP-800 NI or GR8-1200 NI (if available). Refer to the applicable Instruction Manual for proper testing procedures.

2. CHECK "B" TERMINAL CIRCUIT

Check voltage between alternator "B" terminal and ground.

(+)		(-)	Voltage
Alternator			
Connector	Terminal		
E203	1	Ground	Battery voltage

Is the inspection result normal?

YES >> GO TO 3.

NO >> Check harness for open between alternator and fusible link.

3. CHECK "B" TERMINAL CONNECTION (VOLTAGE DROP TEST)

1. Start engine, then engine running at idle and warm.
2. Check voltage between battery positive terminal and alternator "B" terminal.

(+)	(-)		Voltage (V) (Approx.)
	Alternator		
	Connector	Terminal	
Battery positive terminal	E203	1	Less than 0.2

Is the inspection result normal?

YES >> "B" terminal circuit is normal. Refer to [CHG-9, "Work Flow\(With EXP-800 NI or GR8-1200 NI\)"](#) or [CHG-13, "Work Flow\(Without EXP-800 NI or GR8-1200 NI\)"](#).

NO >> Check harness between battery and alternator for poor continuity.

A
B
C
D
E
F
G
H
I
J
K
L
P

CHG

L TERMINAL CIRCUIT (OPEN)

< DTC/CIRCUIT DIAGNOSIS >

L TERMINAL CIRCUIT (OPEN)

Description

INFOID:000000009012374

The "L" terminal circuit controls the charge warning lamp. The charge warning lamp illuminates when the ignition switch is set to ON or START. When the alternator is providing sufficient voltage with the engine running, the charge warning lamp will go off. If the charge warning lamp illuminates with the engine running, a malfunction is indicated.

Diagnosis Procedure

INFOID:000000009012375

1. CHECK "L" TERMINAL CONNECTION

1. Turn ignition switch OFF.
2. Check that "L" terminal is clean and tight.

Is the inspection result normal?

YES >> GO TO 2.

NO >> Repair "L" terminal connection. Confirm repair by performing complete Charging system test using EXP-800 NI or GR8-1200 NI (if available). Refer to the applicable Instruction Manual for proper testing procedures.

2. CHECK "L" TERMINAL CIRCUIT (OPEN)

1. Disconnect alternator connector.
2. Apply ground to alternator harness connector terminal.
3. Check condition of the charge warning lamp with the ignition switch in the ON position.

(+)		(-)	Condition	Charge warning lamp
Alternator				
Connector	Terminal			
E205	3	Ground	Ignition switch ON	ON

Does it illuminate?

YES >> "L" terminal circuit is normal. Refer to [CHG-9. "Work Flow\(With EXP-800 NI or GR8-1200 NI\)"](#) or [CHG-13. "Work Flow\(Without EXP-800 NI or GR8-1200 NI\)"](#).

NO >> GO TO 3.

3. CHECK HARNESS CONTINUITY (OPEN CIRCUIT)

1. Disconnect the battery cable from the negative terminal.
2. Disconnect the combination meter connector.
3. Check continuity between alternator harness connector and combination meter harness connector.

Alternator		Combination meter		Continuity
Connector	Terminal	Connector	Terminal	
E205	3	M34	25	Existed

Is the inspection result normal?

YES >> GO TO 4.

NO >> Repair the harness or connector.

4. CHECK HARNESS CONTINUITY (OPEN CIRCUIT)

Check continuity between combination meter harness connector and fuse block (J/B).

Combination meter		Fuse block (J/B)		Continuity
Connector	Terminal	Connector	Terminal	
M34	2	M1	2A	Existed

Is the inspection result normal?

YES >> GO TO 5.

NO >> Repair the harness or connector.

L TERMINAL CIRCUIT (OPEN)

< DTC/CIRCUIT DIAGNOSIS >

5. CHECK POWER SUPPLY CIRCUIT

1. Connect the battery cable to the negative terminal.
2. Check voltage between combination meter harness connector and ground.

(+)		(-)	Condition	Voltage
Combination meter				
Connector	Terminal			
M34	2	Ground	Ignition switch ON	Battery voltage

Is the inspection result normal?

YES >> Replace combination meter.

NO >> Inspect the power supply circuit. Refer to [PG-31, "Wiring Diagram - IGNITION POWER SUPPLY -](#)

["](#)

A
B
C
D
E
F
G
H
I
J
K
L

CHG

N
O
P

L TERMINAL CIRCUIT (SHORT)

< DTC/CIRCUIT DIAGNOSIS >

L TERMINAL CIRCUIT (SHORT)

Description

INFOID:000000009012376

The "L" terminal circuit controls the charge warning lamp. The charge warning lamp illuminates when the ignition switch is set to ON or START. When the alternator is providing sufficient voltage with the engine running, the charge warning lamp will go off. If the charge warning lamp illuminates with the engine running, a malfunction is indicated.

Diagnosis Procedure

INFOID:000000009012377

1. CHECK "L" TERMINAL CIRCUIT (SHORT)

1. Turn ignition switch OFF.
2. Disconnect alternator connector.
3. Turn ignition switch ON.

Does charge warning lamp illuminate?

YES >> GO TO 2.

NO >> Refer to [CHG-9. "Work Flow\(With EXP-800 NI or GR8-1200 NI\)"](#) or [CHG-13. "Work Flow\(Without EXP-800 NI or GR8-1200 NI\)"](#).

2. CHECK HARNESS CONTINUITY (SHORT CIRCUIT)

1. Turn the ignition switch OFF.
2. Disconnect the battery cable from the negative terminal.
3. Disconnect combination meter connector.
4. Check continuity between combination meter harness connector and ground.

Combination meter		Ground	Continuity
Connector	Terminal		
M34	25		Not existed

Is the inspection result normal?

YES >> Replace combination meter.

NO >> Repair the harness or connector.

S TERMINAL CIRCUIT

< DTC/CIRCUIT DIAGNOSIS >

S TERMINAL CIRCUIT

Description

INFOID:000000009012378

The output voltage of the alternator is controlled by the IC voltage regulator at the "S" terminal detecting the input voltage.

The "S" terminal circuit detects the battery voltage to adjust the alternator output voltage with the IC voltage regulator.

Diagnosis Procedure

INFOID:000000009012379

1. CHECK "S" TERMINAL CONNECTION

1. Turn ignition switch OFF.
2. Check if "S" terminal is clean and tight.

Is the inspection result normal?

YES >> GO TO 2.

NO >> Repair "S" terminal connection. Confirm repair by performing complete Charging system test using EXP-800 NI or GR8-1200 NI (if available). Refer to the applicable Instruction Manual for proper testing procedures.

2. CHECK "S" TERMINAL CIRCUIT

Check voltage between alternator harness connector and ground.

(+)		(-)	Voltage
Alternator			
Connector	Terminal		
E205	4	Ground	Battery voltage

Is the inspection result normal?

YES >> Refer to [CHG-9. "Work Flow\(With EXP-800 NI or GR8-1200 NI\)"](#) or [CHG-13. "Work Flow\(Without EXP-800 NI or GR8-1200 NI\)"](#).

NO >> Check harness for open between alternator and fuse.

A
B
C
D
E
F
G
H
I
J
K
L

CHG

N
O
P

CHARGING SYSTEM

< SYMPTOM DIAGNOSIS >

SYMPTOM DIAGNOSIS

CHARGING SYSTEM

Symptom Table

INFOID:000000009012380

Symptom	Reference
Discharged battery	Refer to CHG-9, "Work Flow(With EXP-800 NI or GR8-1200 NI)" or CHG-13, "Work Flow(Without EXP-800 NI or GR8-1200 NI)" .
The charge warning lamp does not illuminate when the ignition switch is set to ON.	
The charge warning lamp does not turn OFF after the engine starts.	
The charging warning lamp turns ON when increasing the engine speed.	

ALTERNATOR

< REMOVAL AND INSTALLATION >

REMOVAL AND INSTALLATION

ALTERNATOR

Exploded View

INFOID:000000009012381

REMOVAL

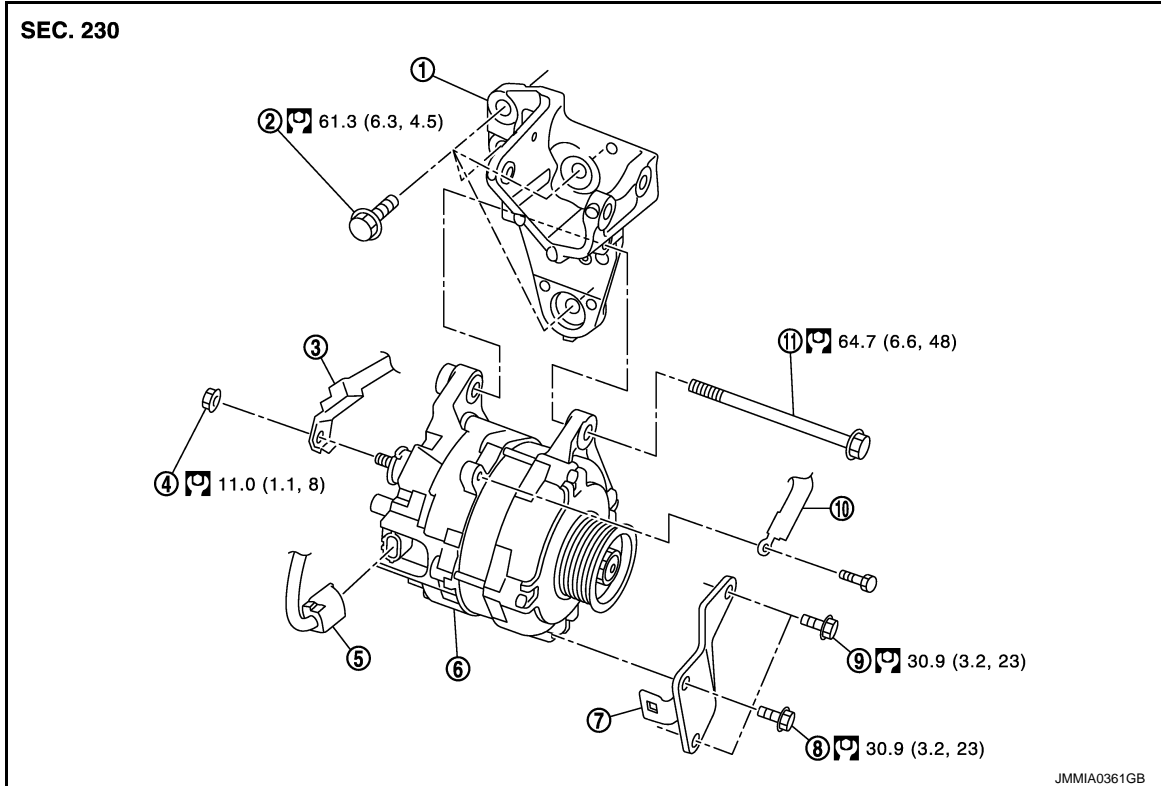

- | | | |
|-----------------------|--------------------------------------|----------------------------------|
| 1. Alternator bracket | 2. Alternator bracket mounting bolt | 3. "B" terminal harness |
| 4. "B" terminal nut | 5. Alternator connector | 6. Alternator |
| 7. Alternator stay | 8. Alternator mounting bolt (lower) | 9. Alternator stay mounting bolt |
| 10. Ground harness | 11. Alternator mounting bolt (upper) | |

 : N·m (kg-m, ft-lb)

DISASSEMBLY

A
B
C
D
E
F
G
H
I
J
K
L

CHG

ALTERNATOR

< REMOVAL AND INSTALLATION >

Type: A002TX1491

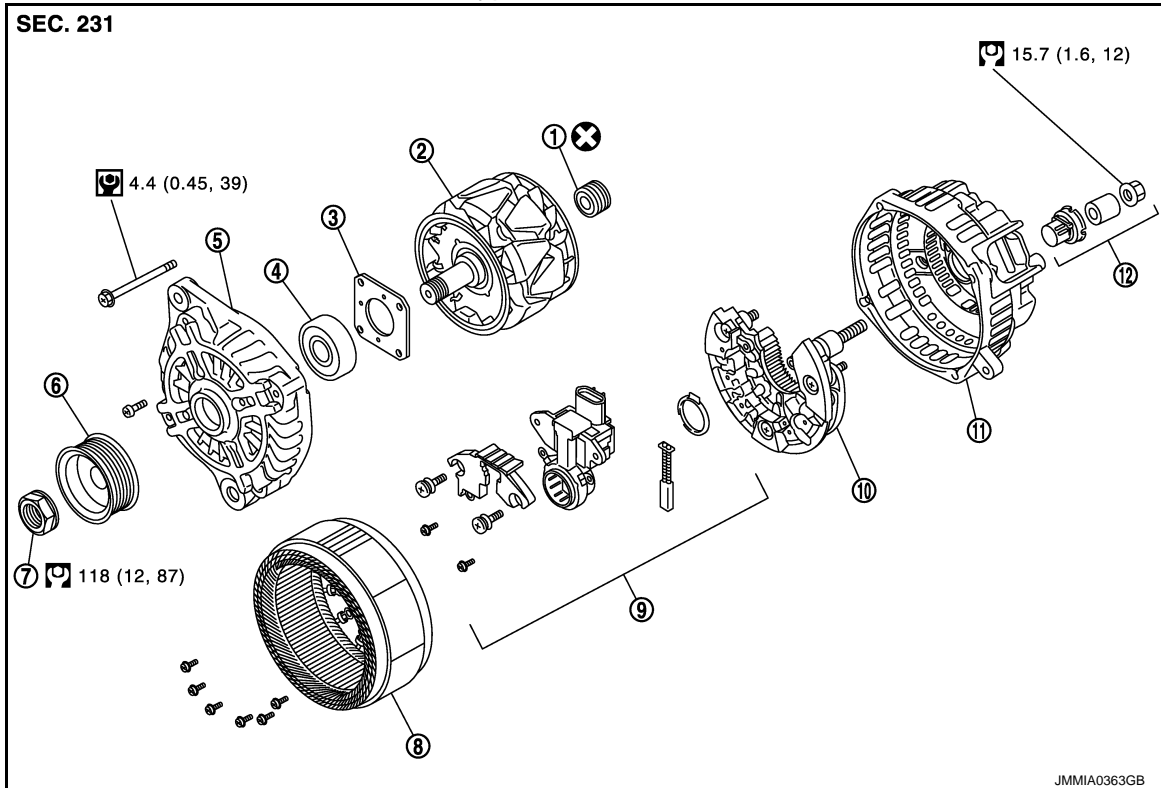

- | | | |
|--------------------|---------------------------|----------------------------------|
| 1. Rear bearing | 2. Rotor assembly | 3. Retainer |
| 4. Front bearing | 5. Front bracket assembly | 6. Pulley |
| 7. Pulley nut | 8. Stator assembly | 9. IC voltage regulator assembly |
| 10. Diode assembly | 11. Rear bracket assembly | 12. Terminal set |

⊗ : Always replace after every disassembly.

⊙ : N·m (kg-m, ft-lb)

⊙ : N·m (kg-m, in-lb)

Removal and Installation

INFOID:000000009012382

REMOVAL

1. Disconnect the battery cable from the negative terminal. Refer to [PG-148, "Removal and Installation"](#).
2. Remove front under cover. Refer to [EXT-25, "Removal and Installation"](#).
3. Remove drive belt. Refer to [EM-20, "Removal and Installation"](#).
4. Disconnect engine oil pressure switch connector (A) and alternator connector (B).
5. Remove harness bracket bolt (C).
6. Remove "B" terminal nut (D) and disconnect "B" terminal harness.

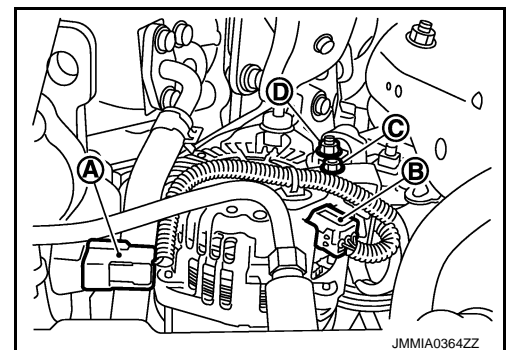

ALTERNATOR

< REMOVAL AND INSTALLATION >

7. Remove ground harness mounting bolt.

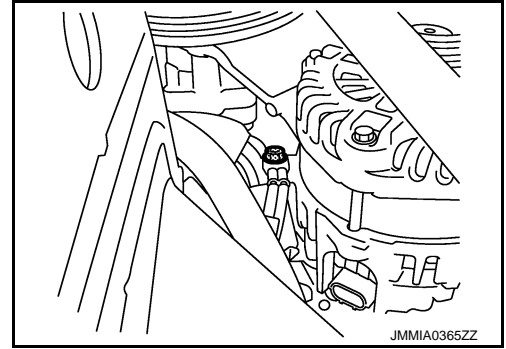

8. Remove alternator mounting bolt (lower), and then alternator mounting bolt (upper).

9. Remove A/T fluid cooler tube (1) from fan shroud (2).

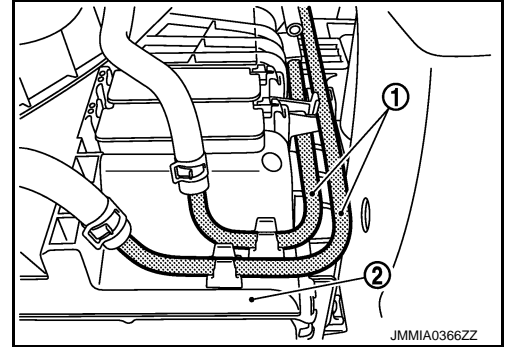

10. Move A/T fluid cooler tube (1) and secure work space.

11. Remove alternator assembly (2) from underneath the vehicle.

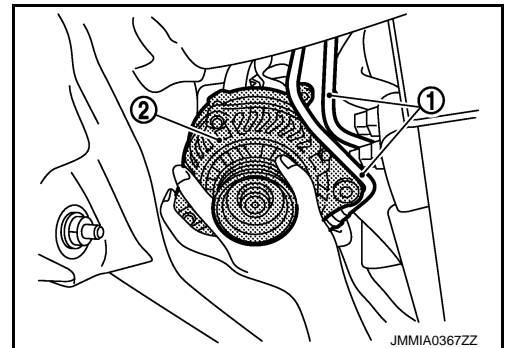

INSTALLATION

Note the following items, and then install in the reverse order of removal.

CAUTION:

- Be careful to tighten "B" terminal nut to the specified torque.
- Install alternator, and check tension of belt. Refer to [EM-20, "Checking"](#).
- For this model, the power generation voltage variable control system that controls the power generation voltage of the alternator has been adopted. Therefore, the power generation voltage variable control system operation inspection should be performed after replacing the alternator, and then make sure that the system operates normally. Refer to [CHG-17, "Inspection Procedure"](#).
- When installing alternator bracket, tighten mounting bolts in numerical order as shown in the figure.

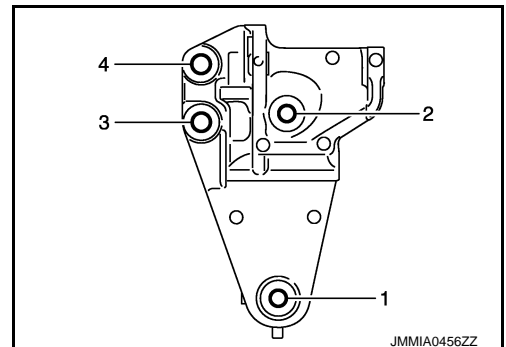

A
B
C
D
E
F
G
H
I
J
K
L

CHG

N
O
P

ALTERNATOR

< REMOVAL AND INSTALLATION >

Inspection

INFOID:000000009012383

ALTERNATOR PULLEY INSPECTION

Perform the following.

- Make sure that alternator pulley does not rattle.
- Make sure that alternator pulley nut is tight. Refer to [CHG-25. "Exploded View"](#).

SERVICE DATA AND SPECIFICATIONS (SDS)

< SERVICE DATA AND SPECIFICATIONS (SDS)

SERVICE DATA AND SPECIFICATIONS (SDS)

SERVICE DATA AND SPECIFICATIONS (SDS)

Alternator

INFOID:000000009012384

Type		A002TX1491
		MITSUBISHI make
Nominal rating	[V - A]	12 -150
Ground polarity		Negative
Minimum revolution under no-load (When 13.5 V is applied)	[rpm]	Less than 1,300
Hot output current (When 13.5 V is applied)	[A/rpm]	More than 57/1,500 More than 126/2,500 More than 152/5,000
Regulated output voltage	[V]	14.1 - 14.7*

*: Adjustment range of power generation voltage variable control is 11.4 - 15.6 V.

A
B
C
D
E
F
G
H
I
J
K
L
N
O
P

CHG