

SECTION **DEF**  
**DEFOGGER**

A  
B  
C  
D  
E  
F  
G  
H  
I  
J  
K  
DEF  
M  
N  
O  
P

CONTENTS

<b>PRECAUTION</b> .....	3	Work Flow .....	16
<b>PRECAUTIONS</b> .....	3	<b>DTC/CIRCUIT DIAGNOSIS</b> .....	17
Precaution for Supplemental Restraint System (SRS) "AIR BAG" and "SEAT BELT PRE-TENSIONER" .....	3	<b>REAR WINDOW DEFOGGER SWITCH</b> .....	17
<b>SYSTEM DESCRIPTION</b> .....	4	Component Function Check .....	17
<b>COMPONENT PARTS</b> .....	4	Diagnosis Procedure .....	17
Component Parts Location .....	4	<b>REAR WINDOW DEFOGGER RELAY</b> .....	18
Component Description .....	4	Component Function Check .....	18
<b>SYSTEM</b> .....	5	Diagnosis Procedure .....	18
System Diagram .....	5	<b>REAR WINDOW DEFOGGER</b> .....	19
System Description .....	5	Component Function Check .....	19
<b>DIAGNOSIS SYSTEM (BCM)</b> .....	6	Diagnosis Procedure .....	19
<b>COMMON ITEM</b> .....	6	<b>DOOR MIRROR DEFOGGER</b> .....	21
COMMON ITEM : CONSULT Function (BCM - COMMON ITEM) .....	6	Component Function Check .....	21
<b>REAR WINDOW DEFOGGER</b> .....	7	Diagnosis Procedure .....	21
REAR WINDOW DEFOGGER : CONSULT Function (BCM - REAR DEFOGGER) .....	7	<b>DRIVER SIDE DOOR MIRROR DEFOGGER</b> ...	22
<b>DIAGNOSIS SYSTEM (IPDM E/R)</b> .....	9	Component Function Check .....	22
Diagnosis Description .....	9	Diagnosis Procedure .....	22
CONSULT Function (IPDM E/R) .....	11	<b>PASSENGER SIDE DOOR MIRROR DEFOGGER</b> .....	23
<b>ECU DIAGNOSIS INFORMATION</b> .....	14	Component Function Check .....	23
<b>BCM, IPDM E/R</b> .....	14	Diagnosis Procedure .....	23
List of ECU Reference .....	14	<b>SYMPTOM DIAGNOSIS</b> .....	24
<b>WIRING DIAGRAM</b> .....	15	<b>ALL DEFOGGER SYSTEMS DO NOT OPERATE</b> .....	24
<b>REAR WINDOW DEFOGGER SYSTEM</b> .....	15	Diagnosis Procedure .....	24
Wiring Diagram .....	15	<b>REAR WINDOW DEFOGGER DOES NOT OPERATE BUT BOTH DOOR MIRROR DEFOGGERS OPERATE</b> .....	25
<b>BASIC INSPECTION</b> .....	16	Diagnosis Procedure .....	25
<b>DIAGNOSIS AND REPAIR WORK FLOW</b> .....	16	<b>DOOR MIRROR DEFOGGER DOES NOT OPERATE</b> .....	26

---

<b>BOTH SIDES</b> .....	<b>26</b>	<b>ON IS NOT DISPLAYED WHEN PRESSING REAR WINDOW DEFOGGER SWITCH BUT IT IS OPERATED</b> .....	<b>28</b>
BOTH SIDES : Description .....	26	Diagnosis Procedure .....	28
BOTH SIDES : Diagnosis Procedure .....	26	<b>REAR WINDOW DEFOGGER INDICATOR DOES NOT ILLUMINATE</b> .....	<b>29</b>
<b>DRIVER SIDE</b> .....	<b>26</b>	Diagnosis Procedure .....	29
DRIVER SIDE : Description .....	26	<b>REMOVAL AND INSTALLATION</b> .....	<b>30</b>
DRIVER SIDE : Diagnosis Procedure .....	26	<b>FILAMENT</b> .....	<b>30</b>
<b>PASSENGER SIDE</b> .....	<b>26</b>	Inspection and Repair .....	30
PASSENGER SIDE : Description .....	26		
PASSENGER SIDE : Diagnosis Procedure .....	26		

# PRECAUTIONS

< PRECAUTION >

## PRECAUTION

### PRECAUTIONS

#### Precaution for Supplemental Restraint System (SRS) "AIR BAG" and "SEAT BELT PRE-TENSIONER"

INFOID:000000009012657

The Supplemental Restraint System such as "AIR BAG" and "SEAT BELT PRE-TENSIONER", used along with a front seat belt, helps to reduce the risk or severity of injury to the driver and front passenger for certain types of collision. Information necessary to service the system safely is included in the "SRS AIR BAG" and "SEAT BELT" of this Service Manual.

**WARNING:**

Always observe the following items for preventing accidental activation.

- To avoid rendering the SRS inoperative, which could increase the risk of personal injury or death in the event of a collision that would result in air bag inflation, all maintenance must be performed by an authorized NISSAN/INFINITI dealer.
- Improper maintenance, including incorrect removal and installation of the SRS, can lead to personal injury caused by unintentional activation of the system. For removal of Spiral Cable and Air Bag Module, see "SRS AIR BAG".
- Never use electrical test equipment on any circuit related to the SRS unless instructed to in this Service Manual. SRS wiring harnesses can be identified by yellow and/or orange harnesses or harness connectors.

#### PRECAUTIONS WHEN USING POWER TOOLS (AIR OR ELECTRIC) AND HAMMERS

**WARNING:**

Always observe the following items for preventing accidental activation.

- When working near the Air Bag Diagnosis Sensor Unit or other Air Bag System sensors with the ignition ON or engine running, never use air or electric power tools or strike near the sensor(s) with a hammer. Heavy vibration could activate the sensor(s) and deploy the air bag(s), possibly causing serious injury.
- When using air or electric power tools or hammers, always switch the ignition OFF, disconnect the battery, and wait at least 3 minutes before performing any service.

A  
B  
C  
D  
E  
F  
G  
H  
I  
J  
K  
DEF  
M  
N  
O  
P

DEF

# COMPONENT PARTS

< SYSTEM DESCRIPTION >

## SYSTEM DESCRIPTION

### COMPONENT PARTS

#### Component Parts Location

INFOID:000000009012658

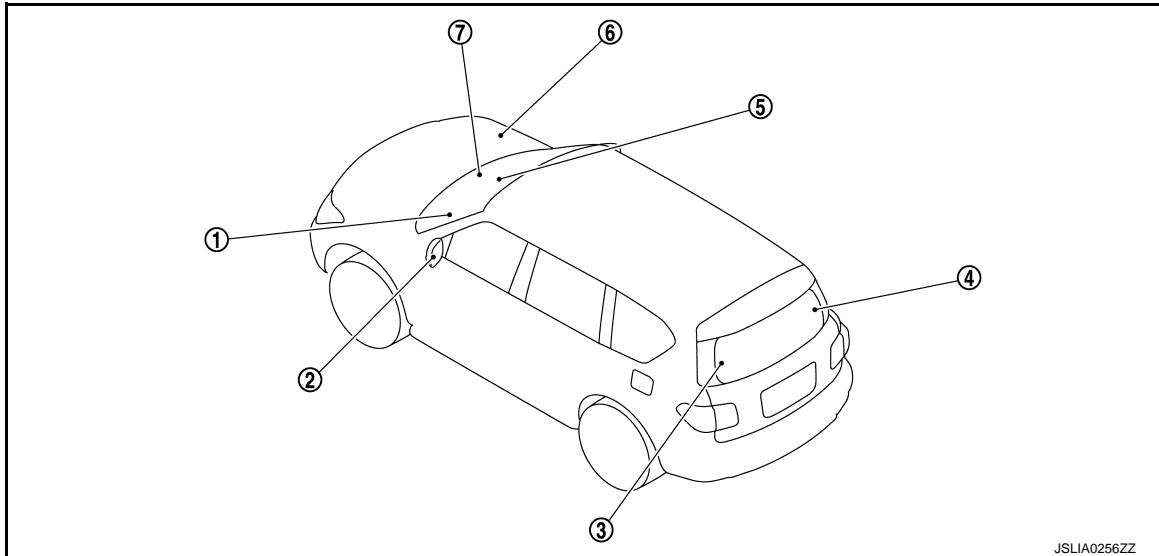

JSLIA0256ZZ

- |  |   |   |
|--|---|---|
| 1. BCM<br>Refer to <a href="#">BCS-4, "BODY CONTROL SYSTEM : Component Parts Location"</a> .   | 2. Door mirror defogger (driver side)                 | 3. Rear window defogger connector   |
| 4. Rear window defogger connector  | 5. Multifunction switch (rear window defogger switch) | 6. IPDM E/R<br>Refer to <a href="#">PCS-4, "Component Parts Location"</a> . |
| 7. AV control unit<br>Refer to <a href="#">AV-12, "Component Parts Location"</a> (Bose audio with navigation) or <a href="#">AV-292, "Component Parts Location"</a> (Telematics system). |   |   |

#### Component Description

INFOID:000000009012659

BCM	<ul style="list-style-type: none"> <li>• Detects rear window defogger switch signal and transmits rear window defogger control signal to IPDM E/R.</li> <li>• Performs the timer control of rear window defogger.</li> </ul>
IPDM E/R	<ul style="list-style-type: none"> <li>• Rear window defogger relay is installed.</li> <li>• Receives rear window defogger control signal from BCM and transmits rear window defogger control signal to AV control unit via CAN communication.</li> <li>• Controls rear window defogger relay to operate rear window defogger and door mirror defogger.</li> </ul>
Multifunction switch	<ul style="list-style-type: none"> <li>• The rear window defogger switch is installed.</li> <li>• Turns the indicator lamp ON when detecting the operation of rear window defogger.</li> </ul>
AV control unit	<ul style="list-style-type: none"> <li>• Transmits rear window defogger switch signal to BCM via CAN communication.</li> <li>• Transmits rear window defogger feedback signal to multifunction switch.</li> <li>• Displays rear window defogger ON to the display when detecting the operation of rear window defogger</li> </ul>
Rear window defogger	Heats the heating wire with the power supply from the rear window defogger relay to prevent the rear window from fogging up.
Door mirror defogger	Heats the heating wire with the power supply from the rear window defogger relay to prevent the door mirror from fogging up.

# SYSTEM

< SYSTEM DESCRIPTION >

## SYSTEM

### System Diagram

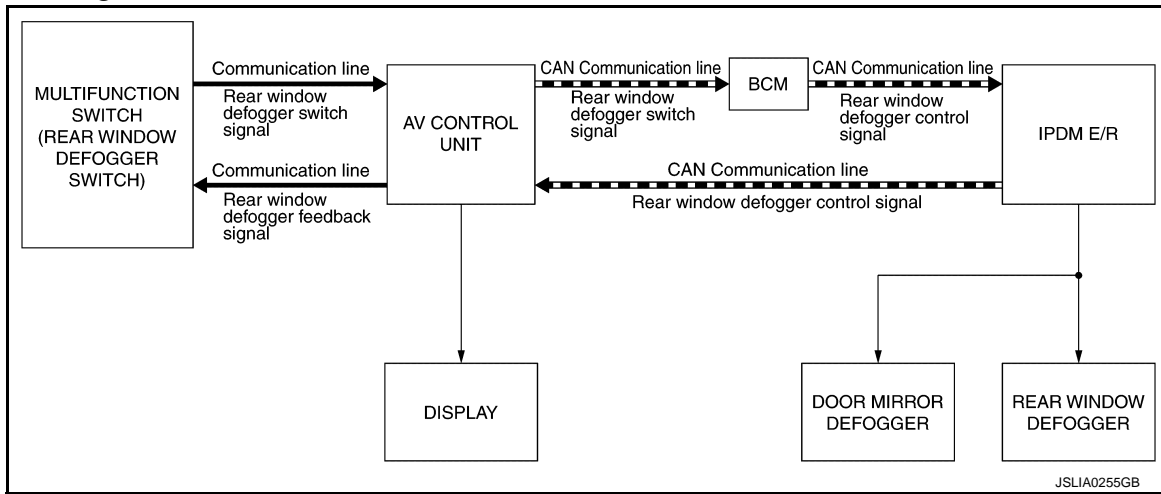

### System Description

INFOID:000000009012661

#### System Description

- Multifunction switch (rear window defogger switch) transmits rear window defogger switch signal to AV control unit via AV communication when rear window defogger switch is turned ON, while ignition switch is ON.
- AV control unit transmits rear window defogger switch signal to BCM via CAN communication.
- BCM transmits rear window defogger control signal to IPDM E/R for approximately 15 minutes via CAN communication when rear window defogger switch signal is received.
- IPDM E/R turns rear window defogger relay ON when rear window defogger control signal is received.
- Power is supplied to rear window defogger and door mirror defoggers when rear window defogger relay is ON.
- IPDM E/R transmits rear window defogger control signal to AV control unit via CAN communication.
- AV control unit transmits rear window defogger feedback signal to multifunction switch (rear window defogger switch) via AV communication.
- AV control unit displays rear window defogger ON to the display when detecting the operation of rear window defogger.

#### Timer function

- BCM transmits rear window defogger control signal to IPDM E/R for approximately 15 minutes when rear window defogger switch is turned ON while ignition switch is ON. Then, IPDM E/R activates rear window defogger and door mirror defoggers.
- Timer is canceled when rear window defogger switch is pressed again during timer operation. BCM stops the output of rear window defogger control signal. The same operation also occurs when the ignition switch is turned OFF during timer operation.

A  
B  
C  
D  
E  
F  
G  
H  
I  
J  
K  
DEF  
M  
N  
O  
P

# DIAGNOSIS SYSTEM (BCM)

< SYSTEM DESCRIPTION >

## DIAGNOSIS SYSTEM (BCM)

### COMMON ITEM

COMMON ITEM : CONSULT Function (BCM - COMMON ITEM)

INFOID:000000009012662

### APPLICATION ITEM

CONSULT performs the following functions via CAN communication with BCM.

Diagnosis mode	Function Description
Work Support	Changes the setting for each system function.
Self Diagnostic Result	Displays the diagnosis results judged by BCM. Refer to <a href="#">BCS-57, "DTC Index"</a> .
CAN Diag Support Monitor	Monitors the reception status of CAN communication viewed from BCM.
Data Monitor	The BCM input/output signals are displayed.
Active Test	The signals used to activate each device are forcibly supplied from BCM.
Ecu Identification	The BCM part number is displayed.
Configuration	<ul style="list-style-type: none"> <li>Read and save the vehicle specification.</li> <li>Write the vehicle specification when replacing BCM.</li> </ul>

### SYSTEM APPLICATION

BCM can perform the following functions for each system.

#### NOTE:

It can perform the diagnosis modes except the following for all sub system selection items.

×: Applicable item

System	Sub system selection item	Diagnosis mode		
		Work Support	Data Monitor	Active Test
Door lock	DOOR LOCK	×	×	×
Rear window defogger	REAR DEFOGGER		×	×
Warning chime	BUZZER		×	×
Interior room lamp timer	INT LAMP	×	×	×
Exterior lamp	HEAD LAMP	×	×	×
Wiper and washer	WIPER	×	×	×
Turn signal and hazard warning lamps	FLASHER	×	×	×
—	AIR CONDITONER*		×	×
<ul style="list-style-type: none"> <li>Intelligent Key system</li> <li>Engine start system</li> </ul>	INTELLIGENT KEY	×	×	×
Combination switch	COMB SW		×	
Body control system	BCM	×		
IVIS	IMMU	×	×	×
Interior room lamp battery saver	BATTERY SAVER	×	×	×
Back door	TRUNK		×	
Vehicle security system	THEFT ALM	×	×	×
RAP system	RETAINED PWR		×	
Signal buffer system	SIGNAL BUFFER		×	×
—	AIR PRESSURE MONITOR*	×	×	×

\*: This item is indicated, but not used.

### FREEZE FRAME DATA (FFD)

The BCM records the following vehicle condition at the time a particular DTC is detected, and displays on CONSULT.

# DIAGNOSIS SYSTEM (BCM)

## < SYSTEM DESCRIPTION >

CONSULT screen item	Indication/Unit	Description		
Vehicle Speed	km/h	Vehicle speed of the moment a particular DTC is detected		A
Odo/Trip Meter	km	Total mileage (Odometer value) of the moment a particular DTC is detected		B
Vehicle Condition	SLEEP>LOCK	Power position status of the moment a particular DTC is detected	While turning BCM status from low power consumption mode to normal mode (Power supply position is "LOCK")	C
	SLEEP>OFF		While turning BCM status from low power consumption mode to normal mode (Power supply position is "OFF".)	D
	LOCK>ACC		While turning power supply position from "LOCK" to "ACC"	E
	ACC>ON		While turning power supply position from "ACC" to "IGN"	F
	RUN>ACC		While turning power supply position from "RUN" to "ACC" (Vehicle is stopping and selector lever is except P position.)	G
	CRANK>RUN		While turning power supply position from "CRANKING" to "RUN" (From cranking up the engine to run it)	H
	RUN>URGENT		While turning power supply position from "RUN" to "ACC" (Emergency stop operation)	I
	ACC>OFF		While turning power supply position from "ACC" to "OFF"	J
	OFF>LOCK		While turning power supply position from "OFF" to "LOCK"	K
	OFF>ACC		While turning power supply position from "OFF" to "ACC"	DEF
	ON>CRANK		While turning power supply position from "IGN" to "CRANKING"	
	OFF>SLEEP		While turning BCM status from normal mode (Power supply position is "OFF".) to low power consumption mode	
	LOCK>SLEEP		While turning BCM status from normal mode (Power supply position is "LOCK".) to low power consumption mode	
	LOCK		Power supply position is "LOCK" (Ignition switch OFF with steering is locked.)	
	OFF		Power supply position is "OFF" (Ignition switch OFF with steering is unlocked.)	
	ACC		Power supply position is "ACC" (Ignition switch ACC)	
	ON		Power supply position is "IGN" (Ignition switch ON with engine stopped)	
ENGINE RUN	Power supply position is "RUN" (Ignition switch ON with engine running)			
CRANKING	Power supply position is "CRANKING" (At engine cranking)			
IGN Counter	0 - 39	The number of times that ignition switch is turned ON after DTC is detected <ul style="list-style-type: none"> <li>• The number is 0 when a malfunction is detected now.</li> <li>• The number increases like 1 → 2 → 3...38 → 39 after returning to the normal condition whenever ignition switch OFF → ON.</li> <li>• The number is fixed to 39 until the self-diagnosis results are erased if it is over 39.</li> </ul>		M

## REAR WINDOW DEFOGGER

### REAR WINDOW DEFOGGER : CONSULT Function (BCM - REAR DEFOGGER)

INFOID:000000009012663

#### DATA MONITOR

##### NOTE:

The following table includes information (items) inapplicable to this vehicle. For information (items) applicable to this vehicle, refer to CONSULT display items.

Monitor Item	Description
REAR DEF SW	This is displayed even when it is not equipped.
PUSH SW	Indicates [ON/OFF] condition of push switch.

## DIAGNOSIS SYSTEM (BCM)

< SYSTEM DESCRIPTION >

---

### ACTIVE TEST

Test Item	Description
REAR DEFOGGER	Rear window defogger operates when "ON" on CONSULT screen is touched.



# DIAGNOSIS SYSTEM (IPDM E/R)

< SYSTEM DESCRIPTION >

## DIAGNOSIS SYSTEM (IPDM E/R)

### Diagnosis Description

INFOID:000000009012664

### AUTO ACTIVE TEST

#### Description

In auto active test, the IPDM E/R sends a drive signal to the following systems to check their operation.

- Oil pressure warning lamp
- Rear window defogger
- Front wiper (LO, HI)
- Parking lamp
- License plate lamp
- Tail lamp
- Side marker lamp
- Front fog lamp
- Headlamp (LO, HI)
- A/C compressor (magnet clutch)

#### Operation Procedure

##### **CAUTION:**

**Never perform auto active test in the following conditions.**

- **Engine is running.**
- **CONSULT is connected.**

1. Close the hood and lift the wiper arms from the windshield. (Prevent windshield damage due to wiper operation)

##### **NOTE:**

When auto active test is performed with hood opened, sprinkle water on windshield beforehand.

2. Turn the ignition switch OFF.
3. Turn the ignition switch ON, and within 20 seconds, press the driver door switch 10 times. Then turn the ignition switch OFF.

##### **CAUTION:**

**Close passenger door.**

4. Turn the ignition switch ON within 10 seconds. After that the horn sounds once and the auto active test starts.

##### **CAUTION:**

**Engine starts when ignition switch is turned ON while brake pedal is depressed.**

5. The oil pressure warning lamp starts blinking when the auto active test starts.
6. After a series of the following operations is repeated 3 times, auto active test is completed.

##### **NOTE:**

- When auto active test has to be cancelled halfway through test, turn the ignition switch OFF.
- When auto active test is not activated, door switch may be the cause. Check door switch. Refer to [DLK-98](#), "[Component Function Check](#)".

#### Inspection in Auto Active Test

When auto active test is actuated, the following operation sequence is repeated 3 times.

Operation sequence	Inspection location	Operation
1	Oil pressure warning lamp	Blinks continuously during operation of auto active test
2	Rear window defogger	10 seconds
3	Front wiper	LO for 5 seconds → HI for 5 seconds
4	<ul style="list-style-type: none"><li>• Parking lamp</li><li>• License plate lamp</li><li>• Tail lamp</li><li>• Side marker lamp</li><li>• Front fog lamp</li></ul>	10 seconds

# DIAGNOSIS SYSTEM (IPDM E/R)

## < SYSTEM DESCRIPTION >

Operation sequence	Inspection location	Operation
5	Headlamp	LO for 10 seconds → HI ON ↔ OFF 5 times
6	A/C compressor (magnet clutch)	ON ↔ OFF 5 times

### Concept of auto active test

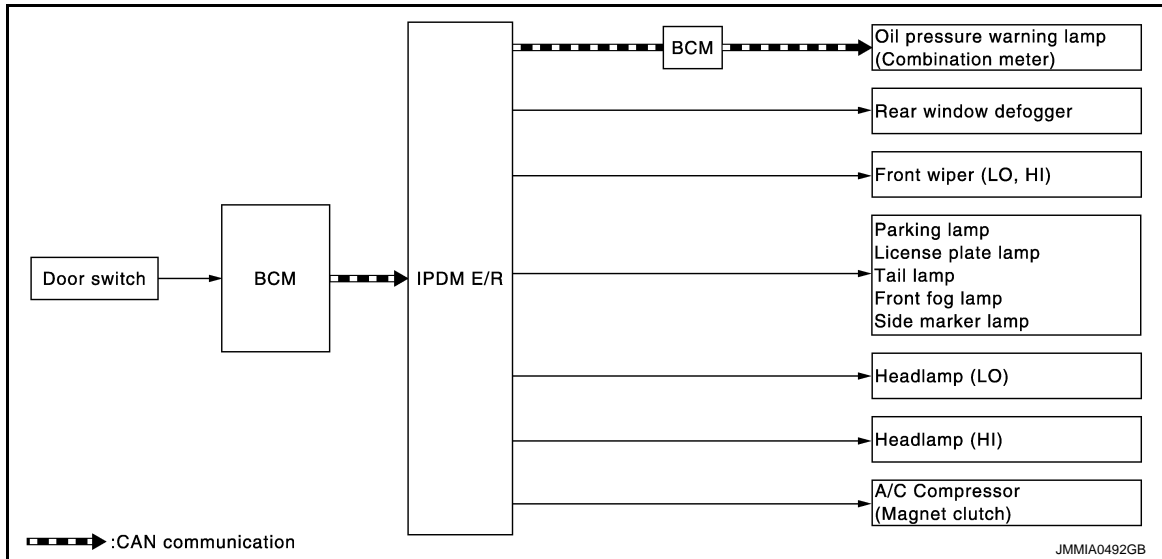

- IPDM E/R starts the auto active test with the door switch signals transmitted by BCM via CAN communication. Therefore, the CAN communication line between IPDM E/R and BCM is considered normal if the auto active test starts successfully.
- The auto active test facilitates troubleshooting if any systems controlled by IPDM E/R cannot be operated.

### Diagnosis chart in auto active test

Symptom	Inspection contents	Possible cause
Rear window defogger does not operate	Perform auto active test. Does the rear window defogger operate?	YES BCM signal input circuit
		NO <ul style="list-style-type: none"> <li>• Rear window defogger</li> <li>• Rear window defogger ground circuit</li> <li>• Harness or connector between IPDM E/R and rear window defogger</li> <li>• IPDM E/R</li> </ul>
Any of the following components do not operate <ul style="list-style-type: none"> <li>• Parking lamp</li> <li>• License plate lamp</li> <li>• Tail lamp</li> <li>• Side marker lamp</li> <li>• Front fog lamp</li> <li>• Headlamp (HI, LO)</li> <li>• Front wiper (HI, LO)</li> </ul>	Perform auto active test. Does the applicable system operate?	YES BCM signal input circuit
		NO <ul style="list-style-type: none"> <li>• Lamp or motor</li> <li>• Lamp or motor ground circuit</li> <li>• Harness or connector between IPDM E/R and applicable system</li> <li>• IPDM E/R</li> </ul>
A/C compressor does not operate	Perform auto active test. Does the magnet clutch operate?	YES <ul style="list-style-type: none"> <li>• A/C auto amp. signal input circuit</li> <li>• CAN communication signal between A/C auto amp. and ECM</li> <li>• CAN communication signal between ECM and IPDM E/R</li> </ul>
		NO <ul style="list-style-type: none"> <li>• Magnet clutch</li> <li>• Harness or connector between IPDM E/R and magnet clutch</li> <li>• IPDM E/R</li> </ul>

# DIAGNOSIS SYSTEM (IPDM E/R)

## < SYSTEM DESCRIPTION >

Symptom	Inspection contents		Possible cause
Oil pressure warning lamp does not operate	Perform auto active test. Does the oil pressure warning lamp blink?	YES	<ul style="list-style-type: none"> <li>• Harness or connector between IPDM E/R and oil pressure switch</li> <li>• Oil pressure switch</li> <li>• IPDM E/R</li> </ul>
		NO	<ul style="list-style-type: none"> <li>• CAN communication signal between IPDM E/R and BCM</li> <li>• CAN communication signal between BCM and combination meter</li> <li>• Combination meter</li> </ul>

## CONSULT Function (IPDM E/R)

INFOID:000000009012665

### APPLICATION ITEM

CONSULT performs the following functions via CAN communication with IPDM E/R.

Diagnosis mode	Description
Ecu Identification	Allows confirmation of IPDM E/R part number.
Self Diagnostic Result	Displays the diagnosis results judged by IPDM E/R.
Data Monitor	Displays the real-time input/output data from IPDM E/R input/output data.
Active Test	IPDM E/R can provide a drive signal to electronic components to check their operations.
CAN Diag Support Monitor	The results of transmit/receive diagnosis of CAN communication can be read.

### SELF DIAGNOSTIC RESULT

Refer to [PCS-22, "DTC Index"](#).

### DATA MONITOR

#### NOTE:

The following table includes information (items) inapplicable to this vehicle. For information (items) applicable to this vehicle, refer to CONSULT display items.

Monitor Item [Unit]	MAIN SIGNALS	Description
RAD FAN REQ [1/2/3/4]	×	Displays the value of the cooling fan speed request signal received from ECM via CAN communication.
AC COMP REQ [Off/On]	×	Displays the status of the A/C compressor request signal received from ECM via CAN communication.
TAIL&CLR REQ [Off/On]	×	Displays the status of the position light request signal received from BCM via CAN communication.
HL LO REQ [Off/On]	×	Displays the status of the low beam request signal received from BCM via CAN communication.
HL HI REQ [Off/On]	×	Displays the status of the high beam request signal received from BCM via CAN communication.
FR FOG REQ [Off/On]	×	Displays the status of the front fog light request signal received from BCM via CAN communication.
FR WIP REQ [Stop/1LOW/Low/Hi]	×	Displays the status of the front wiper request signal received from BCM via CAN communication.
WIP AUTO STOP [STOP P/ACT P]	×	Displays the status of the front wiper auto stop signal judged by IPDM E/R.
WIP PROT [Off/BLOCK]	×	Displays the status of the front wiper fail-safe operation judged by IPDM E/R.
IGN RLY1 -REQ [Off/On]		Displays the status of the ignition switch ON signal received from BCM via CAN communication.

## DIAGNOSIS SYSTEM (IPDM E/R)

### < SYSTEM DESCRIPTION >

Monitor Item [Unit]	MAIN SIG- NALS	Description
IGN RLY [Off/On]	×	Displays the status of the ignition relay judged by IPDM E/R.
PUSH SW [Off/On]		Displays the status of the push-button ignition switch judged by IPDM E/R.
INTER/NP SW [Off/On]		Displays the status of the shift position judged by IPDM E/R.
ST RLY CONT [Off/On]		Displays the status of the starter relay status signal received from BCM via CAN communication.
IHBT RLY -REQ [Off/On]		Displays the status of the starter control relay signal received from BCM via CAN communication.
ST/INHI RLY [Off/ ST ON/INHI ON/UNKWN]		Displays the status of the starter relay and starter control relay judged by IPDM E/R.
DETENT SW [Off/On]		Displays the status of the A/T shift selector (detention switch) judged by IPDM E/R.
S/L RLY -REQ [Off/On]		<b>NOTE:</b> The item is indicated, but not monitored.
S/L STATE [LOCK/UNLK/UNKWN]		<b>NOTE:</b> The item is indicated, but not monitored.
OIL P SW [Open/Close]		Displays the status of the oil pressure switch judged by IPDM E/R.
HOOD SW [Off/On]		Displays the status of the hood switch judged by IPDM E/R.
HL WASHER REQ [Off/On]		Displays the status of the headlamp washer request signal received from BCM via CAN communication.
THFT HRN REQ [Off/On]		Displays the status of the theft warning horn request signal received from BCM via CAN communication.
HORN CHIRP [Off/On]		Displays the status of the horn reminder signal received from BCM via CAN communication.

### ACTIVE TEST

Test item	Operation	Description
CORNERING LAMP	LH	<b>NOTE:</b> This item is indicated, but cannot be tested.
	RH	
HORN	On	Operates horn relay for 20 ms.
REAR DEFOGGER	Off	OFF
	On	Operates the rear window defogger relay.
FRONT WIPER	Off	OFF
	Lo	Operates the front wiper relay.
	Hi	Operates the front wiper relay and front wiper high relay.
MOTOR FAN*	1	OFF
	2	Transmits 50% pulse duty signal (PWM signal) to the cooling fan control module.
	3	Transmits 75% pulse duty signal (PWM signal) to the cooling fan control module.
	4	Transmits 100% pulse duty signal (PWM signal) to the cooling fan control module.
HEAD LAMP WASHER	On	Operates the headlamp washer relay for 1 second.

# DIAGNOSIS SYSTEM (IPDM E/R)

## < SYSTEM DESCRIPTION >

Test item	Operation	Description
EXTERNAL LAMPS	Off	OFF
	TAIL	Operates the tail lamp relay.
	Lo	Operates the headlamp low relay.
	Hi	Operates the headlamp low relay and ON/OFF the headlamp high relay at 1 second intervals.
	Fog	Operates the front fog lamp relay.

\*: Operates while the engine is running.

A  
B  
C  
D  
E  
F  
G  
H  
I  
J  
K  
DEF  
M  
N  
O  
P

DEF

# BCM, IPDM E/R

< ECU DIAGNOSIS INFORMATION >

## ECU DIAGNOSIS INFORMATION

BCM, IPDM E/R

List of ECU Reference

INFOID:000000009012666

ECU	Reference
BCM	<a href="#">BCS-35, "Reference Value"</a>
	<a href="#">BCS-56, "Fail-safe"</a>
	<a href="#">BCS-57, "DTC Inspection Priority Chart"</a>
	<a href="#">BCS-57, "DTC Index"</a>
IPDM E/R	<a href="#">PCS-15, "Reference Value"</a>
	<a href="#">PCS-20, "Fail-safe"</a>
	<a href="#">PCS-22, "DTC Index"</a>

# REAR WINDOW DEFOGGER SYSTEM

< WIRING DIAGRAM >

## WIRING DIAGRAM

### REAR WINDOW DEFOGGER SYSTEM

#### Wiring Diagram

INFOID:000000009012667

For connector terminal arrangements, harness layouts, and alphabets in a  (option abbreviation; if not described in wiring diagram), refer to [GI-12. "Connector Information"](#).

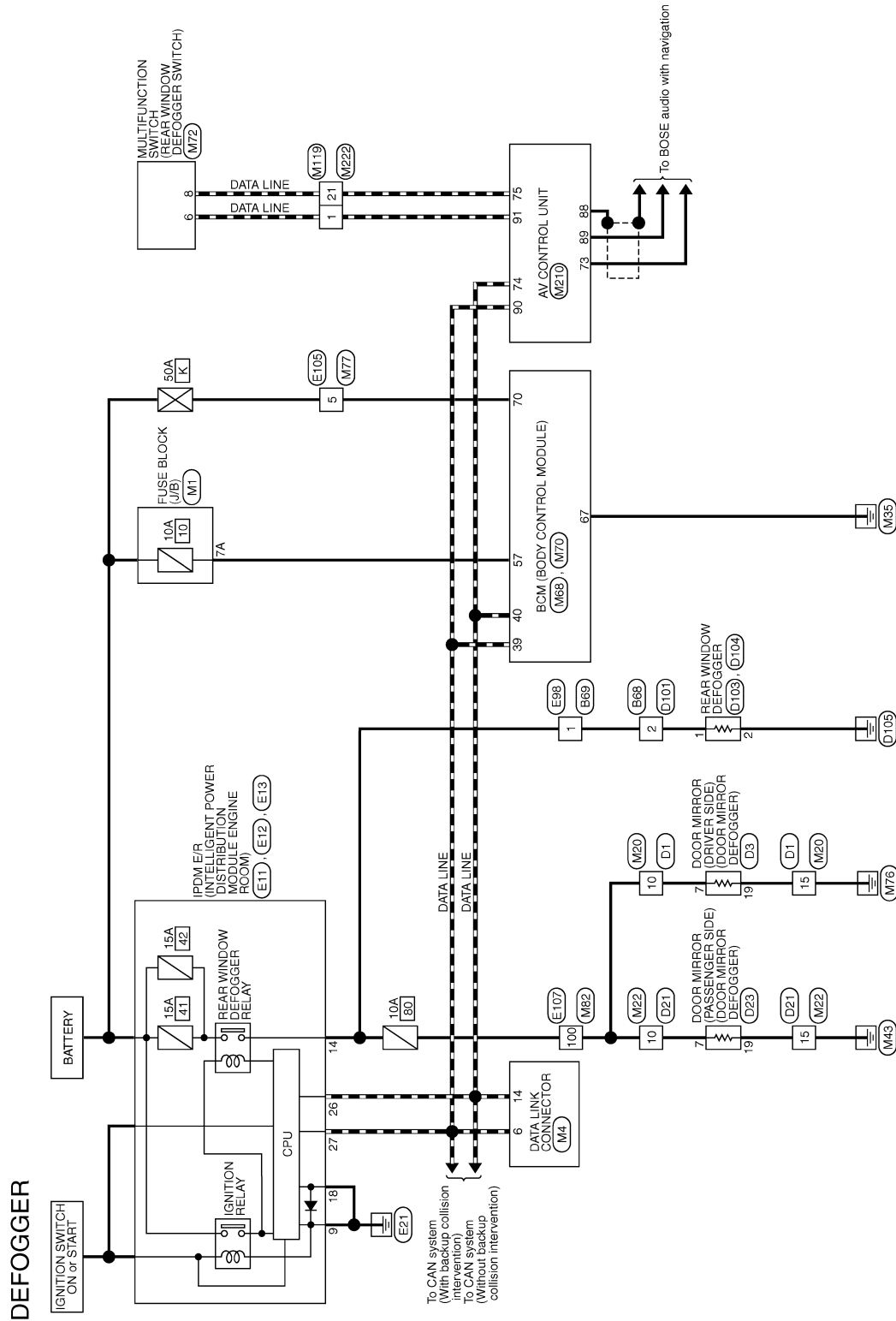

A  
B  
C  
D  
E  
F  
G  
H  
I  
J  
K  
DEF  
M  
N  
O  
P

# DIAGNOSIS AND REPAIR WORK FLOW

< BASIC INSPECTION >

## BASIC INSPECTION

### DIAGNOSIS AND REPAIR WORK FLOW

#### Work Flow

INFOID:000000009012668

#### DETAILED FLOW

##### 1.OBTAIN INFORMATION ABOUT SYMPTOM

Interview the customer to obtain the malfunction information (conditions and environment when the malfunction occurred) as much as possible when the customer brings the vehicle in.

>> GO TO 2.

##### 2.CHECK FOR DTC

Perform self diagnosis with CONSULT

Is any DTC detected?

YES-1 >> BCM: Refer to [BCS-57, "DTC Index"](#).

YES-2 >> IPDM E/R: Refer to [PCS-22, "DTC Index"](#).

NO >> GO TO 3.

##### 3.REPRODUCE THE MALFUNCTION INFORMATION

Check the malfunction on the vehicle that the customer describes.  
Inspect the relation of the symptoms and the condition when the symptoms occur.

>> GO TO 4.

##### 4.IDENTIFY THE MALFUNCTIONING SYSTEM WITH "SYMPTOM DIAGNOSIS"

Use "Symptom diagnosis" from the symptom inspection result in step 3. Then identify where to start performing the diagnosis based on possible causes and symptoms.

>> GO TO 5.

##### 5.IDENTIFY MALFUNCTIONING PARTS WITH "COMPONENT DIAGNOSIS"

Perform the diagnosis with "Component diagnosis" of the applicable system.

>> GO TO 6.

##### 6.REPAIR OR REPLACE THE MALFUNCTIONING PARTS

Repair or replace the specified malfunctioning parts.

>> GO TO 7.

##### 7.FINAL CHECK

Check that malfunctions are not reproduced when obtaining the malfunction information from the customer, referring to the symptom inspection result in step 3.

Are all malfunctions corrected?

YES >> INSPECTION END

NO >> GO TO 4.



# REAR WINDOW DEFOGGER SWITCH

< DTC/CIRCUIT DIAGNOSIS >

## DTC/CIRCUIT DIAGNOSIS

### REAR WINDOW DEFOGGER SWITCH

#### Component Function Check

INFOID:000000009012669

#### 1.CHECK REAR WINDOW DEFOGGER SWITCH FUNCTION

Check that the indicator lamp of rear window defogger illuminates when rear window defogger switch ON.

Is the inspection result normal?

- YES >> Rear window defogger switch function is OK.
- NO >> Refer to [DEF-17. "Diagnosis Procedure"](#).

#### Diagnosis Procedure

INFOID:000000009012670

#### 1.CHECK MULTIFUNCTION SWITCH (REAR WINDOW DEFOGGER SWITCH)

Does multifunction switch operate normally?

Refer to [AV-37. "On Board Diagnosis Function"](#).

Is the inspection result normal?

- YES >> INSPECTION END
- NO >> Replace multifunction switch (rear window defogger switch).

A  
B  
C  
D  
E  
F  
G  
H  
I  
J  
K  
M  
N  
O  
P

DEF

# REAR WINDOW DEFOGGER RELAY

< DTC/CIRCUIT DIAGNOSIS >

## REAR WINDOW DEFOGGER RELAY

### Component Function Check

INFOID:000000009012671

#### 1.CHECK FUNCTION

1. Perform IPDM E/R Active Test ("REAR DEFOGGER") using CONSULT.
2. Touch "ON".
3. Check that the rear window heating wire is getting warmer.

Is the inspection result normal?

- YES >> Rear window defogger relay function is OK.  
NO >> Refer to [DEF-18. "Diagnosis Procedure"](#).

### Diagnosis Procedure

INFOID:000000009012672

#### 1.CHECK FUSE

1. Turn ignition switch OFF.
2. Check the 15A fuse (No. 41, 42 located in IPDM E/R).

Is the inspection result normal?

- YES >> GO TO 2.  
NO >> Replace the blown fuse after repairing the affected circuit if a fuse is blown.

#### 2.CHECK IPDM E/R OUTPUT SIGNAL

1. Turn ignition switch ON.
2. Perform IPDM E/R Active Test ("REAR DEFOGGER") using CONSULT.
3. Touch "ON".
4. Check voltage between IPDM E/R harness connector and ground.

(+)		(-)	CONSULT Active Test condition	Voltage (V) (Approx.)	
IPDM E/R					
Connector	Terminal				
E11	14	Ground	REAR DEFOGGER	ON	Battery voltage
				OFF	0

Is the inspection result normal?

- YES >> INSPECTION END  
NO >> Replace IPDM E/R.

# REAR WINDOW DEFOGGER

< DTC/CIRCUIT DIAGNOSIS >

## REAR WINDOW DEFOGGER

### Component Function Check

INFOID:000000009012673

#### 1.CHECK FUNCTION

1. Perform IPDM E/R Active Test ("REAR DEFOGGER") using CONSULT.
2. Touch "ON".
3. Check that the rear window heating wire is getting warmer.

Is the inspection result normal?

- YES >> Rear window defogger function is OK.  
 NO >> Refer to [DEF-19. "Diagnosis Procedure"](#).

### Diagnosis Procedure

INFOID:000000009012674

#### 1.CHECK REAR WINDOW DEFOGGER POWER SUPPLY CIRCUIT

1. Turn ignition switch OFF.
2. Disconnect rear window defogger connector.
3. Turn ignition switch ON.
4. Check voltage between rear window defogger harness connector and ground.

(+)		(-)	Condition	Voltage (V) (Approx.)
Connector	Terminal			
D103	1	Ground	Rear window defogger switch	ON Battery voltage
			OFF 0	

Is the inspection result normal?

- YES >> GO TO 2.  
 NO >> GO TO 4.

#### 2.CHECK REAR WINDOW DEFOGGER GROUND CIRCUIT

1. Turn ignition switch OFF.
2. Check continuity between rear window defogger harness connector and ground.

Rear window defogger		Ground	Continuity
Connector	Terminal		
D104	2		Existed

Is the inspection result normal?

- YES >> GO TO 3.  
 NO >> Repair or replace harness.

#### 3.CHECK FILAMENT

Refer to [DEF-30. "Inspection and Repair"](#).

Is the inspection result normal?

- YES >> GO TO 5.  
 NO >> Repair filament.

#### 4.CHECK REAR WINDOW DEFOGGER POWER SUPPLY CIRCUIT

1. Turn ignition switch OFF.
2. Disconnect IPDM E/R connector.
3. Check continuity between IPDM E/R harness connector and rear window defogger harness connector.

IPDM E/R		Rear window defogger		Continuity
Connector	Terminal	Connector	Terminal	
E11	14	D103	1	Existed

DEF

A  
B  
C  
D  
E  
F  
G  
H  
I  
J  
K  
M  
N  
O  
P

## REAR WINDOW DEFOGGER

< DTC/CIRCUIT DIAGNOSIS >

---

Is the inspection result normal?

YES >> GO TO 5.

NO >> Repair or replace harness.

**5.**CHECK INTERMITTENT INCIDENT

---

Check intermittent incident.

Refer to [GI-43, "Intermittent Incident"](#).

>> INSPECTION END

# DOOR MIRROR DEFOGGER

< DTC/CIRCUIT DIAGNOSIS >

## DOOR MIRROR DEFOGGER

### Component Function Check

INFOID:000000009012675

#### 1.CHECK DOOR MIRROR DEFOGGER

1. Perform IPDM E/R Active Test ("REAR DEFOGGER") using CONSULT.
2. Touch "ON".
3. Check that both side door mirror glasses are getting warmer.

Is the inspection result normal?

- YES >> Door mirror defogger function is OK.  
NO >> Refer to [DEF-21, "Diagnosis Procedure"](#).

### Diagnosis Procedure

INFOID:000000009012676

#### 1.CHECK FUSE

1. Turn ignition switch OFF.
2. Check 10A fuse (No.80).

Is the inspection result normal?

- YES >> GO TO 2.  
NO >> Replace the blown fuse after repairing the affected circuit if a fuse is blown.

#### 2.CHECK DOOR MIRROR DEFOGGER CIRCUIT

1. Disconnect IPDM E/R connector and door mirror (driver sides) connector.
2. Check continuity between IPDM E/R harness connector and door mirror (driver side) harness connector.

IPDM E/R		Door mirror (driver side)		Continuity
Connector	Terminal	Connector	Terminal	
E11	14	D3	7	Existed

Is the inspection result normal?

- YES >> GO TO 3.  
NO >> Repair or replace harness.

#### 3.CHECK INTERMITTENT INCIDENT

Check intermittent incident.

Refer to [GI-43, "Intermittent Incident"](#).

>> INSPECTION END

A  
B  
C  
D  
E  
F  
G  
H  
I  
J  
K  
DEF  
M  
N  
O  
P

# DRIVER SIDE DOOR MIRROR DEFOGGER

< DTC/CIRCUIT DIAGNOSIS >

## DRIVER SIDE DOOR MIRROR DEFOGGER

### Component Function Check

INFOID:000000009012677

#### 1.CHECK DRIVER SIDE DOOR MIRROR DEFOGGER

1. Perform IPDM E/R Active Test ("REAR DEFOGGER") using CONSULT.
2. Touch "ON".
3. Check that the driver side door mirror glass is getting warmer.

Is the inspection result normal?

- YES >> Driver side door mirror defogger is OK.  
NO >> Refer to [DEF-22, "Diagnosis Procedure"](#).

### Diagnosis Procedure

INFOID:000000009012678

#### 1.CHECK POWER SUPPLY CIRCUIT

1. Turn ignition switch OFF.
2. Disconnect IPDM E/R connector and door mirror (driver side) connector.
3. Check continuity between IPDM E/R harness connector and door mirror (driver side) harness connector.

IPDM E/R		Door mirror defogger (driver side)		Continuity
Connector	Terminal	Connector	Terminal	
E11	14	D3	7	Existed

Is the inspection result normal?

- YES >> GO TO 2.  
NO >> Repair or replace harness.

#### 2.CHECK GROUND CIRCUIT

1. Turn ignition switch OFF.
2. Check continuity between door mirror (driver side) harness connector and ground.

Door mirror (driver side)		Ground	Continuity
Connector	Terminal		
D3	19		Existed

Is the inspection result normal?

- YES >> Replace door mirror glass (driver side).  
NO >> Repair or replace harness.

# PASSENGER SIDE DOOR MIRROR DEFOGGER

< DTC/CIRCUIT DIAGNOSIS >

## PASSENGER SIDE DOOR MIRROR DEFOGGER

### Component Function Check

INFOID:000000009012679

#### 1. CHECK PASSENGER SIDE DOOR MIRROR DEFOGGER

1. Perform IPDM E/R Active Test ("REAR DEFOGGER") using CONSULT.
2. Touch "ON".
3. Check that the passenger side door mirror glass is getting warmer.

Is the inspection result normal?

- YES >> Passenger side door mirror defogger is OK.  
NO >> Refer to [DEF-23. "Diagnosis Procedure"](#).

### Diagnosis Procedure

INFOID:000000009012680

#### 1. CHECK POWER SUPPLY CIRCUIT

1. Turn ignition switch OFF.
2. Disconnect IPDM E/R connector and door mirror (passenger side) connector.
3. Check continuity between IPDM E/R harness connector and door mirror (passenger side) harness connector.

IPDM E/R		Door mirror defogger (passenger side)		Continuity
Connector	Terminal	Connector	Terminal	
E11	14	D23	7	Existed

Is the inspection result normal?

- YES >> GO TO 2.  
NO >> Repair or replace harness.

#### 2. CHECK GROUND CIRCUIT

1. Turn ignition switch OFF.
2. Check continuity between door mirror (passenger side) harness connector and ground.

Door mirror (passenger side)		Ground	Continuity
Connector	Terminal		
D23	19		Existed

Is the inspection result normal?

- YES >> Replace door mirror glass (passenger side).  
NO >> Repair or replace harness.

A  
B  
C  
D  
E  
F  
G  
H  
I  
J  
K  
DEF  
M  
N  
O  
P

# ALL DEFOGGER SYSTEMS DO NOT OPERATE

< SYMPTOM DIAGNOSIS >

---

## SYMPTOM DIAGNOSIS

### ALL DEFOGGER SYSTEMS DO NOT OPERATE

#### Diagnosis Procedure

INFOID:000000009012681

#### 1. CHECK REAR WINDOW DEFOGGER SWITCH

---

Check rear window defogger switch.

Refer to [DEF-17, "Component Function Check"](#).

Is the inspection result normal?

YES >> GO TO 2.

NO >> Repair or replace the malfunctioning parts.

#### 2. CHECK REAR WINDOW DEFOGGER RELAY

---

Check rear window defogger relay.

Refer to [DEF-18, "Component Function Check"](#).

Is the inspection result normal?

YES >> GO TO 3.

NO >> Repair or replace the malfunctioning parts.

#### 3. CHECK DOOR MIRROR DEFOGGER

---

Check door mirror defogger.

Refer to [DEF-21, "Component Function Check"](#).

Is the inspection result normal?

YES >> GO TO 4.

NO >> Repair or replace the malfunctioning parts.

#### 4. CONFIRM THE OPERATION

---

Confirm the operation again.

Is the inspection result normal?

YES >> Check intermittent incident. Refer to [GI-43, "Intermittent Incident"](#).

NO >> GO TO 1.



# REAR WINDOW DEFOGGER DOES NOT OPERATE BUT BOTH DOOR MIRROR DEFOGGERS OPERATE

< SYMPTOM DIAGNOSIS >

## REAR WINDOW DEFOGGER DOES NOT OPERATE BUT BOTH DOOR MIRROR DEFOGGERS OPERATE

### Diagnosis Procedure

INFOID:000000009012682

#### 1. CHECK REAR WINDOW DEFOGGER

Check rear window defogger.

Refer to [DEF-19, "Component Function Check"](#).

Is the inspection result normal?

YES >> GO TO 2.

NO >> Repair or replace the malfunctioning parts.

#### 2. CONFIRM THE OPERATION

Confirm the operation again

Is the inspection result normal?

YES >> Check intermittent incident. Refer to [GI-43, "Intermittent Incident"](#).

NO >> GO TO 1.

A  
B  
C  
D  
E  
F  
G  
H  
I  
J  
K  
DEF  
M  
N  
O  
P

# DOOR MIRROR DEFOGGER DOES NOT OPERATE

< SYMPTOM DIAGNOSIS >

---

## DOOR MIRROR DEFOGGER DOES NOT OPERATE BOTH SIDES

### BOTH SIDES : Description

INFOID:000000009012683

Driver side and passenger side door mirror defoggers do not operate.

### BOTH SIDES : Diagnosis Procedure

INFOID:000000009012684

#### 1.CHECK DOOR MIRROR DEFOGGER

---

Check door mirror defogger.

Refer to [DEF-21, "Component Function Check"](#).

Is the inspection result normal?

YES >> GO TO 2.

NO >> Repair or replace the malfunctioning parts.

#### 2.CONFIRM THE OPERATION

---

Confirm the operation again.

Is the inspection result normal?

YES >> Check intermittent incident. Refer to [GI-43, "Intermittent Incident"](#).

NO >> GO TO 1.

## DRIVER SIDE

### DRIVER SIDE : Description

INFOID:000000009012685

Driver side door mirror defogger does not operate but passenger side door mirror defogger operates.

### DRIVER SIDE : Diagnosis Procedure

INFOID:000000009012686

#### 1.CHECK DRIVER SIDE DOOR MIRROR DEFOGGER

---

Check driver side door mirror defogger.

Refer to [DEF-22, "Component Function Check"](#).

Is the inspection result normal?

YES >> GO TO 2.

NO >> Repair or replace the malfunctioning parts.

#### 2.CONFIRM THE OPERATION

---

Confirm the operation again.

Is the inspection result normal?

YES >> Check intermittent incident. Refer to [GI-43, "Intermittent Incident"](#).

NO >> GO TO 1.

## PASSENGER SIDE

### PASSENGER SIDE : Description

INFOID:000000009012687

Passenger side door mirror defogger does not operate but driver side door mirror defogger operates.

### PASSENGER SIDE : Diagnosis Procedure

INFOID:000000009012688

#### 1.CHECK PASSENGER SIDE DOOR MIRROR DEFOGGER.

---

Check passenger side door mirror defogger.

Refer to [DEF-23, "Component Function Check"](#).

Is the inspection result normal?

YES >> GO TO 2.

NO >> Repair or replace the malfunctioning parts.

#### 2.CONFIRM THE OPERATION

# DOOR MIRROR DEFOGGER DOES NOT OPERATE

## < SYMPTOM DIAGNOSIS >

---

Confirm the operation again.

Is the inspection result normal?

- YES >> Check intermittent incident. Refer to [GI-43. "Intermittent Incident"](#).
- NO >> GO TO 1.

A  
B  
C  
D  
E  
F  
G  
H  
I  
J  
K  
DEF  
M  
N  
O  
P

# ON IS NOT DISPLAYED WHEN PRESSING REAR WINDOW DEFOGGER SWITCH BUT IT IS OPERATED

< SYMPTOM DIAGNOSIS >

---

## ON IS NOT DISPLAYED WHEN PRESSING REAR WINDOW DEFOGGER SWITCH BUT IT IS OPERATED

### Diagnosis Procedure

INFOID:000000009012689

#### 1. CHECK AV CONTROL UNIT FUNCTION

---

Check that the AV control unit is operating normally.

Refer to [AV-108, "Work Flow \(Multi AV\)"](#) (BOSE audio with navigation) or [AV-314, "Work Flow"](#) (Telematics system).

Is the inspection result normal?

YES >> GO TO 2.

NO >> Repair or replace the malfunctioning parts.

#### 2. CONFIRM THE OPERATION

---

Confirm the operation again.

Is the inspection result normal?

YES >> Check intermittent incident. Refer to [GI-43, "Intermittent Incident"](#).

NO >> GO TO 1.

# REAR WINDOW DEFOGGER INDICATOR DOES NOT ILLUMINATE

< SYMPTOM DIAGNOSIS >

## REAR WINDOW DEFOGGER INDICATOR DOES NOT ILLUMINATE

### Diagnosis Procedure

INFOID:000000009012690

#### 1.CHECK AV CONTROL UNIT FUNCTION

Check that the AV control unit is operating normally.

Refer to [AV-108, "Work Flow \(Multi AV\)"](#) (BOSE audio with navigation) or [AV-314, "Work Flow"](#) (Telematics system).

Is the inspection result normal?

YES >> GO TO 2.

NO >> Repair or replace the malfunctioning parts.

#### 2.CHECK MULTIFUNCTION SWITCH

Check that the multifunction switch is operating normally.

Refer to [AV-37, "On Board Diagnosis Function"](#).

Is the inspection result normal?

YES >> GO TO 3.

NO >> Repair or replace the malfunctioning parts.

#### 3.CONFIRM THE OPERATION

Confirm the operation again.

Is the inspection result normal?

YES >> Check intermittent incident. Refer to [GI-43, "Intermittent Incident"](#).

NO >> GO TO 1.

A  
B  
C  
D  
E  
F  
G  
H  
I  
J  
K  
DEF  
M  
N  
O  
P

# FILAMENT

< REMOVAL AND INSTALLATION >

## REMOVAL AND INSTALLATION

### FILAMENT

#### Inspection and Repair

INFOID:000000009012691

#### INSPECTION

1. When measuring voltage, wrap tin foil around the top of the negative probe. Then press the foil against the wire with your finger.

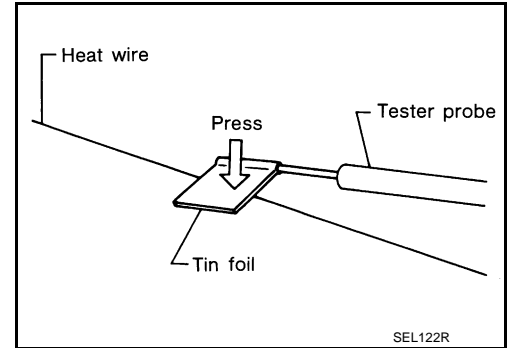

2. Attach probe circuit tester (in Volt range) to middle portion of each filament.

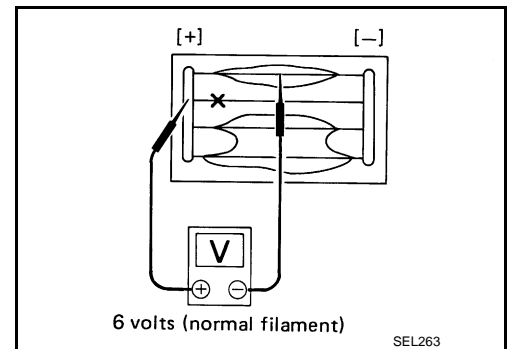

3. If a filament is burned out, circuit tester registers 0 or battery voltage.
4. To locate burned out point, move probe to left and right along filament. Test needle will swing abruptly when probe passes the point.

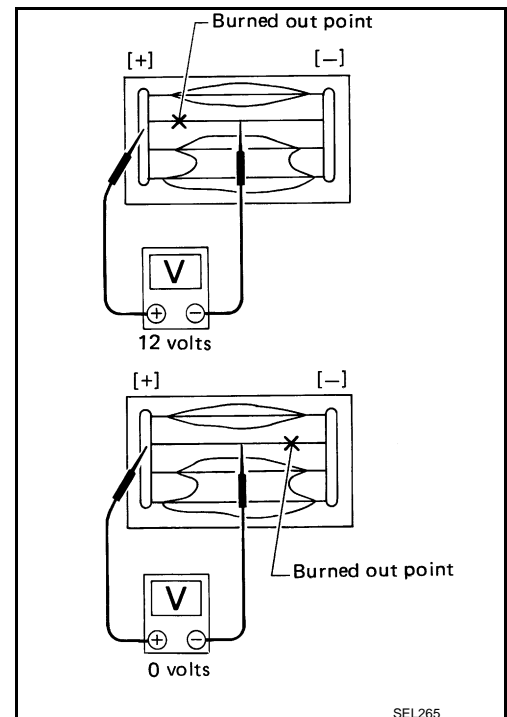

#### REPAIR

##### REPAIR EQUIPMENT

- Conductive silver composition (Dupont No. 4817 or equivalent)

# FILAMENT

## < REMOVAL AND INSTALLATION >

- Ruler 30 cm (11.8 in) long
- Drawing pen
- Heat gun
- Alcohol
- Cloth

### REPAIRING PROCEDURE

1. Wipe broken heat wire and its surrounding area clean with a cloth dampened in alcohol.
2. Apply a small amount of conductive silver composition to tip of drawing pen. Shake silver composition container before use.
3. Place ruler on glass along broken line. Deposit conductive silver composition on break with drawing pen. Slightly overlap existing heat wire on both sides [preferably 5 mm (0.20 in)] of the break.

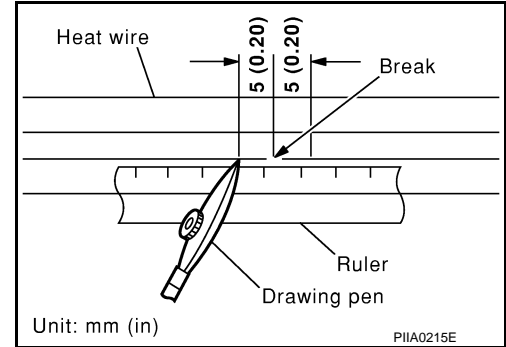

4. After repair has been completed, check repaired wire for continuity. This check should be conducted 10 minutes after silver composition is deposited. Do not touch repaired area while test is being conducted.

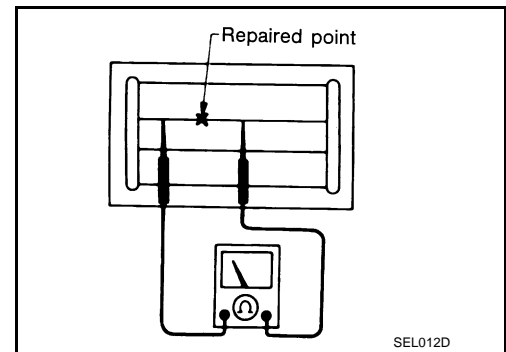

5. Apply a constant stream of hot air directly to the repaired area for approximately 20 minutes with a heat gun. A minimum distance of 3 cm (1.2 in) should be kept between repaired area and hot air outlet. If a heat gun is not available, let the repaired area dry for 24 hours.

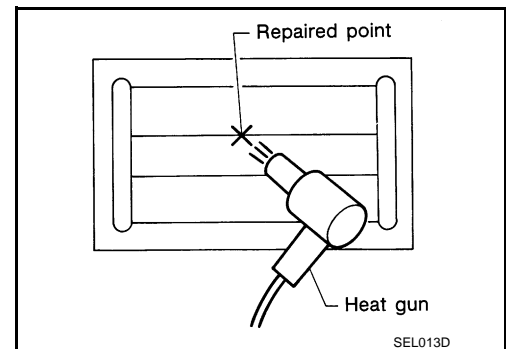

A  
B  
C  
D  
E  
F  
G  
H  
I  
J  
K  
DEF  
M  
N  
O  
P