

SECTION **INL**

INTERIOR LIGHTING SYSTEM

A
B
C
D
E
F
G
H
I
J
K
INL
M
N
O
P

CONTENTS

<p>PRECAUTION 3</p> <p>PRECAUTIONS 3</p> <p style="padding-left: 20px;">Precaution for Supplemental Restraint System (SRS) "AIR BAG" and "SEAT BELT PRE-TENSIONER"3</p> <p>SYSTEM DESCRIPTION 4</p> <p>COMPONENT PARTS 4</p> <p style="padding-left: 20px;">Component Parts Location4</p> <p style="padding-left: 20px;">Component Description4</p> <p>SYSTEM 6</p> <p>INTERIOR ROOM LAMP CONTROL SYSTEM6</p> <p style="padding-left: 20px;">INTERIOR ROOM LAMP CONTROL SYSTEM : System Diagram6</p> <p style="padding-left: 20px;">INTERIOR ROOM LAMP CONTROL SYSTEM : System Description6</p> <p>INTERIOR ROOM LAMP BATTERY SAVER SYSTEM8</p> <p style="padding-left: 20px;">INTERIOR ROOM LAMP BATTERY SAVER SYSTEM : System Diagram9</p> <p style="padding-left: 20px;">INTERIOR ROOM LAMP BATTERY SAVER SYSTEM : System Description9</p> <p>ILLUMINATION CONTROL SYSTEM10</p> <p style="padding-left: 20px;">ILLUMINATION CONTROL SYSTEM : System Diagram 10</p> <p style="padding-left: 20px;">ILLUMINATION CONTROL SYSTEM : System Description 10</p> <p>AUTO LIGHT ADJUSTMENT SYSTEM10</p> <p style="padding-left: 20px;">AUTO LIGHT ADJUSTMENT SYSTEM : System Diagram 11</p> <p style="padding-left: 20px;">AUTO LIGHT ADJUSTMENT SYSTEM : System Description 11</p> <p>DIAGNOSIS SYSTEM (BCM)12</p> <p>COMMON ITEM 12</p>	<p>COMMON ITEM : CONSULT Function (BCM - COMMON ITEM)12</p> <p>INT LAMP13</p> <p style="padding-left: 20px;">INT LAMP : CONSULT Function (BCM - INT LAMP) 14</p> <p>BATTERY SAVER15</p> <p style="padding-left: 20px;">BATTERY SAVER : CONSULT Function (BCM - BATTERY SAVER) 15</p> <p>ECU DIAGNOSIS INFORMATION17</p> <p>BCM17</p> <p style="padding-left: 20px;">List of ECU Reference17</p> <p>WIRING DIAGRAM 18</p> <p>INTERIOR ROOM LAMP CONTROL SYSTEM18</p> <p style="padding-left: 20px;">Wiring Diagram18</p> <p>ILLUMINATION22</p> <p style="padding-left: 20px;">Wiring Diagram22</p> <p>BASIC INSPECTION27</p> <p>DIAGNOSIS AND REPAIR WORK FLOW27</p> <p style="padding-left: 20px;">Work Flow27</p> <p>DTC/CIRCUIT DIAGNOSIS30</p> <p>INTERIOR ROOM LAMP POWER SUPPLY CIRCUIT30</p> <p style="padding-left: 20px;">Description30</p> <p style="padding-left: 20px;">Component Function Check30</p> <p style="padding-left: 20px;">Diagnosis Procedure30</p> <p>INTERIOR ROOM LAMP CONTROL CIRCUIT33</p> <p style="padding-left: 20px;">Description33</p> <p style="padding-left: 20px;">Component Function Check33</p> <p style="padding-left: 20px;">Diagnosis Procedure33</p>
---	--

LUGGAGE ROOM LAMP CIRCUIT	35	PASSENGER SIDE	46
Description	35	PASSENGER SIDE : Exploded View	46
Diagnosis Procedure	35	PASSENGER SIDE : Replacement	47
STEP LAMP CIRCUIT	37	REAR FOOT LAMP	47
Description	37	REAR FOOT LAMP : Exploded View	47
Component Function Check	37	REAR FOOT LAMP : Removal and Installation	47
Diagnosis Procedure	37	STEP LAMP	49
PUDDLE LAMP CIRCUIT	39	Exploded View	49
Description	39	Removal and Installation	49
Diagnosis Procedure	39	Replacement	49
PUSH-BUTTON IGNITION SWITCH ILLUMINATION CIRCUIT	40	MOOD LAMP	50
Component Function Check	40	FRONT DOOR ARMREST	50
Diagnosis Procedure	40	FRONT DOOR ARMREST : Exploded View	50
SYMPTOM DIAGNOSIS	42	FRONT DOOR ARMREST : Replacement	50
INTERIOR LIGHTING SYSTEM SYMPTOMS ...	42	REAR DOOR ARMREST	50
Symptom Table	42	REAR DOOR ARMREST : Exploded View	50
REMOVAL AND INSTALLATION	43	REAR DOOR ARMREST : Replacement	51
MAP LAMP	43	PERSONAL LAMP	52
Exploded View	43	Exploded View	52
Removal and Installation	43	Removal and Installation	52
Replacement	43	Replacement	53
VANITY MIRROR LAMP	44	PUDDLE LAMP	54
Exploded View	44	Exploded View	54
Replacement	44	Removal and Installation	54
GLOVE BOX LAMP	45	LUGGAGE ROOM LAMP	56
Exploded View	45	Exploded View	56
Replacement	45	Removal and Installation	56
FOOT LAMP	46	Replacement	56
DRIVER SIDE	46	SERVICE DATA AND SPECIFICATIONS (SDS)	57
DRIVER SIDE : Exploded View	46	SERVICE DATA AND SPECIFICATIONS (SDS)	57
DRIVER SIDE : Replacement	46	Bulb Specifications	57

PRECAUTIONS

< PRECAUTION >

PRECAUTION

PRECAUTIONS

Precaution for Supplemental Restraint System (SRS) "AIR BAG" and "SEAT BELT PRE-TENSIONER"

INFOID:000000009010352

The Supplemental Restraint System such as "AIR BAG" and "SEAT BELT PRE-TENSIONER", used along with a front seat belt, helps to reduce the risk or severity of injury to the driver and front passenger for certain types of collision. Information necessary to service the system safely is included in the "SRS AIR BAG" and "SEAT BELT" of this Service Manual.

WARNING:

Always observe the following items for preventing accidental activation.

- To avoid rendering the SRS inoperative, which could increase the risk of personal injury or death in the event of a collision that would result in air bag inflation, all maintenance must be performed by an authorized NISSAN/INFINITI dealer.
- Improper maintenance, including incorrect removal and installation of the SRS, can lead to personal injury caused by unintentional activation of the system. For removal of Spiral Cable and Air Bag Module, see "SRS AIR BAG".
- Never use electrical test equipment on any circuit related to the SRS unless instructed to in this Service Manual. SRS wiring harnesses can be identified by yellow and/or orange harnesses or harness connectors.

PRECAUTIONS WHEN USING POWER TOOLS (AIR OR ELECTRIC) AND HAMMERS

WARNING:

Always observe the following items for preventing accidental activation.

- When working near the Air Bag Diagnosis Sensor Unit or other Air Bag System sensors with the ignition ON or engine running, never use air or electric power tools or strike near the sensor(s) with a hammer. Heavy vibration could activate the sensor(s) and deploy the air bag(s), possibly causing serious injury.
- When using air or electric power tools or hammers, always switch the ignition OFF, disconnect the battery, and wait at least 3 minutes before performing any service.

A
B
C
D
E
F
G
H
I
J
K
L
M
N
O
P

INL

COMPONENT PARTS

< SYSTEM DESCRIPTION >

SYSTEM DESCRIPTION

COMPONENT PARTS

Component Parts Location

INFOID:000000009010353

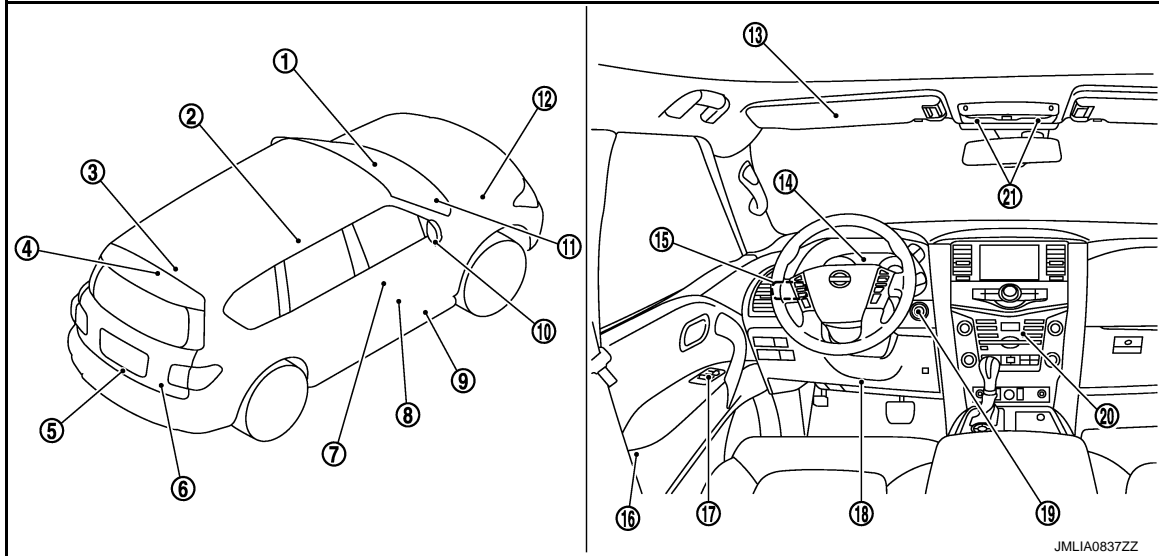

- | | | |
|--|---|--|
| 1. BCM
Refer to BCS-4, "BODY CONTROL SYSTEM : Component Parts Location" | 2. Personal lamp | 3. Luggage room lamp |
| 4. Remote keyless entry receiver
Refer to DLK-10, "DOOR LOCK SYSTEM : Component Parts Location" | 5. Back door lock assembly (back door switch) | 6. Automatic back door close switch |
| 7. Door request switch | 8. Door switch | 9. Step lamp |
| 10. Paddle lamp | 11. Optical sensor | 12. IPDM E/R
Refer to PCS-4, "Component Parts Location" |
| 13. Vanity mirror lamp | 14. Combination meter | 15. Combination switch |
| 16. Front door lock assembly (driver side) (door key cylinder switch, unlock sensor) | 17. Door lock and unlock switch | 18. Foot lamp |
| 19. Push-button ignition switch | 20. AV control unit
Refer to AV-12, "Component Parts Location" | 21. Map lamp |

Component Description

INFOID:000000009010354

Part	Description
BCM	Controls the interior lighting system.
IPDM E/R	Controls the integrated relay according to the request signal from BCM (via CAN communication).
Remote keyless entry receiver	Refer to DLK-11, "DOOR LOCK SYSTEM : Component Description" .
AV control unit	Receives the dimmer signal from BCM via CAN communication.
Optical sensor	Refer to EXL-7, "EXTERIOR LIGHTING SYSTEM : Component Description" .
Unlock sensor	Detects door lock condition of driver side door.

COMPONENT PARTS

< SYSTEM DESCRIPTION >

Part	Description
Combination switch (Lighting & turn signal switch)	Refer to BCS-8, "COMBINATION SWITCH READING SYSTEM : System Description" .
<ul style="list-style-type: none">• Door lock and unlock switch• Door request switch• Door key cylinder switch	Inputs the lock/unlock signal to BCM.
<ul style="list-style-type: none">• Door switch• Back door switch	Inputs the door switch signal to BCM.

A
B
C
D
E
F
G
H
I
J
K
M
N
O
P

INL

SYSTEM

< SYSTEM DESCRIPTION >

SYSTEM

INTERIOR ROOM LAMP CONTROL SYSTEM

INTERIOR ROOM LAMP CONTROL SYSTEM : System Diagram

INFOID:000000009010355

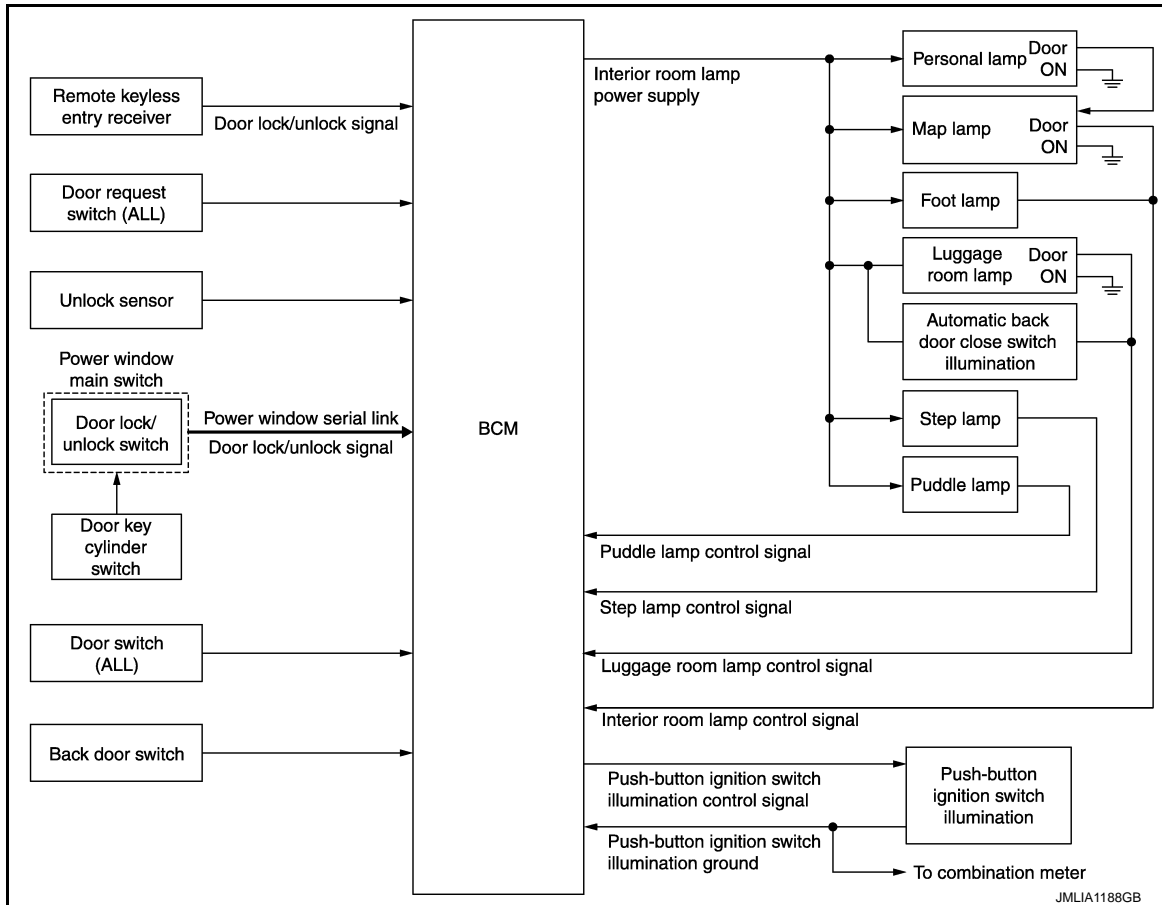

INTERIOR ROOM LAMP CONTROL SYSTEM : System Description

INFOID:000000009010356

OUTLINE

- Interior room lamps* are controlled by interior room lamp timer control function of BCM.
*: Map lamp, foot lamp and personal lamp (when map lamp switch and personal lamp switch are in DOOR position).
- Step lamp is controlled by step lamp control function of BCM.
- Luggage room lamp and automatic back door close switch illumination are controlled by luggage room lamp control function of BCM.
- Puddle lamp is controlled by puddle lamp timer control function of BCM.
- Push-button ignition switch illumination is controlled by the push-button ignition switch illumination control function of BCM and combination meter.
- Interior room lamps and puddle lamp are illuminated by welcome light function of Intelligent Key system. Refer to [DLK-26. "WELCOME LIGHT FUNCTION : System Description"](#).

INTERIOR ROOM LAMP TIMER CONTROL

SYSTEM

< SYSTEM DESCRIPTION >

Interior Room Lamp Timer Basic Operation

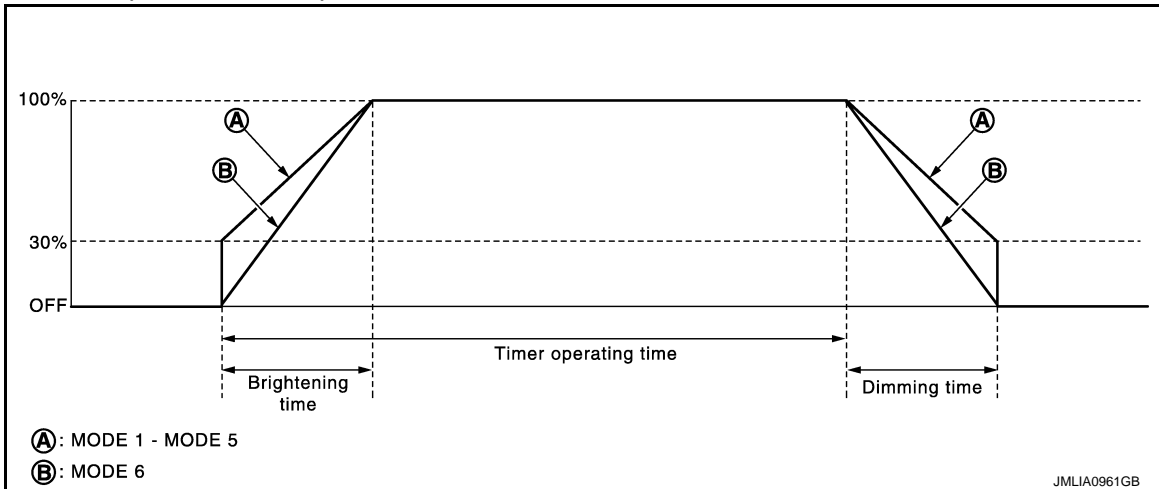

NOTE:

A: Sets the interior room lamp gradual brightening and dimming time.

B: Gradually brightens from 0% to 100% and gradually dims from 100% to 0% in 1 second.

- The interior room lamp turns ON and OFF (gradual brightening and dimming) by the interior room lamp timer.
- BCM judges the vehicle condition with the following items. It activates the interior room timer.
 - Ignition switch status
 - Door switch signal (except back door)
 - Door lock/unlock signal (remote keyless entry receiver, each door request switch, door key cylinder switch, door lock/unlock switch)

NOTE:

Each function of interior room lamp timer can be set by CONSULT. Refer to [INL-14, "INT LAMP : CONSULT Function \(BCM - INT LAMP\)"](#).

Interior Room Lamp ON Operation

- BCM always turns the interior room lamp ON when any door opens excepting back door.
- When all doors are closed, and any all door unlock operation is performed or ignition switch is turned OFF, BCM brightens interior room lamp to 30% brightness and maintains 30% brightness until any door opens.
- BCM activates the interior room timer in any of the following conditions to turn the interior room lamp ON for a period of time.
 - Any door opens before all doors close excepting back door.
 - Ignition switch is turned ON → OFF.
 - Any door unlock signal is detected when all doors close excepting back door with ignition switch OFF.

NOTE:

The timer restarts if new condition is input during the timer operating time.

Interior Room Lamp OFF Operation

BCM stops the timer and turns interior room lamp OFF, when any of the following conditions is satisfied.

- The interior room lamp timer operating time is expired with all doors closed excepting back door.
- Ignition switch position is other than OFF with all doors close excepting back door.
- Any door lock signal is detected with all doors close excepting back door.

LUGGAGE ROOM LAMP CONTROL

BCM controls the luggage room lamp and automatic back door close switch illumination (ground-side) to turn ON with back door switch ON.

- When luggage room lamp switch is turned to the ON position, luggage room lamp turns ON.
- When luggage room lamp switch is in the DOOR position and back door is opened, luggage room lamp turns ON.
- When back door is opened, automatic back door close switch illumination turn ON.

STEP LAMP CONTROL

BCM controls the step lamp (ground-side) to turn ON with any door switch ON excepting back door.

PUDDLE LAMP TIMER CONTROL

Puddle Lamp Timer Basic Operation

- BCM controls the ground to turn the puddle lamp ON.

SYSTEM

< SYSTEM DESCRIPTION >

- The puddle lamp turns ON and OFF by the puddle lamp timer.
- BCM judges the vehicle condition with the following items. It activates the puddle lamp timer.
 - Ignition switch status
 - Door switch signal (except back door)
 - Door lock/unlock signal (remote keyless entry receiver, each door request switch)
 - Driver side door lock status

Puddle Lamp ON Operation

BCM activates the puddle lamp timer in any of the following conditions to turn the puddle lamp ON for a period of time.

- Any door opens excepting back door.
- Any door opens before all doors close excepting back door.
- Ignition switch is turned ON → OFF.
- Door unlock signal by remote keyless entry receiver or each door request switch is detected.
- Driver side door is locked*.

NOTE:

The timer restarts if new condition is input during the timer operating time.

Puddle Lamp OFF Operation

BCM stops the timer and turns puddle lamp OFF, when any of the following conditions are satisfied.

- The puddle lamp timer operating time is expired.
- The interior room lamp OFF conditions.
- The interior room lamp timer operating time is expired.

PUSH-BUTTON IGNITION SWITCH ILLUMINATION CONTROL

Push-button Ignition Switch Illumination Basic Operation

- BCM controls the ON/OFF status of push-button ignition switch illumination according to vehicle status.
- BCM provides the push-button ignition switch illumination control signal and the ground to turn the push-button ignition switch illumination ON.
- BCM cuts the ground supply while each illumination (tail lamp) is ON. BCM switches to the ground control according to the meter illumination control function. Refer to [MWI-17. "METER ILLUMINATION CONTROL : System Description"](#).

Heart Beat Operation

BCM repeats brightening and dimming operation of push-button ignition switch illumination when any of the following conditions are satisfied.

- Welcome light function operates.
- When ignition switch is OFF and any of the following conditions are satisfied.
 - Driver side door changes from closed to open
 - Driver side door changes from locked to unlocked
 - Intelligent Key ID comparison is OK and driver side door changes from open to closed
 - ID comparison by Intelligent Key transponder is OK

Illumination ON Operation

When ignition switch is not OFF or tail lamp turns ON, push-button ignition switch illumination turns ON.

Dimming Operation

When tail lamp turns OFF and ignition switch is turned OFF, push-button ignition switch illumination dims to 50% brightness.

Illumination OFF Operation

Push-button ignition switch illumination turns OFF when ignition switch turns OFF and tail lamp turns from ON to OFF, while push-button ignition switch illumination is in ON status.

When push-button ignition switch illumination is at 50% brightness or in heartbeat status, and any of the following conditions are satisfied, push-button ignition switch illumination turns OFF.

- 15 seconds after start of heartbeat operation.
- When welcome light function is not operating and any on the following conditions is satisfied.
 - Driver side door is closed
 - Driver side door is locked
 - Intelligent Key ID comparison is NG
 - Comparison of Intelligent Key ID by transponder is NG

INTERIOR ROOM LAMP BATTERY SAVER SYSTEM

SYSTEM

< SYSTEM DESCRIPTION >

INTERIOR ROOM LAMP BATTERY SAVER SYSTEM : System Diagram

INFOID:000000009010357

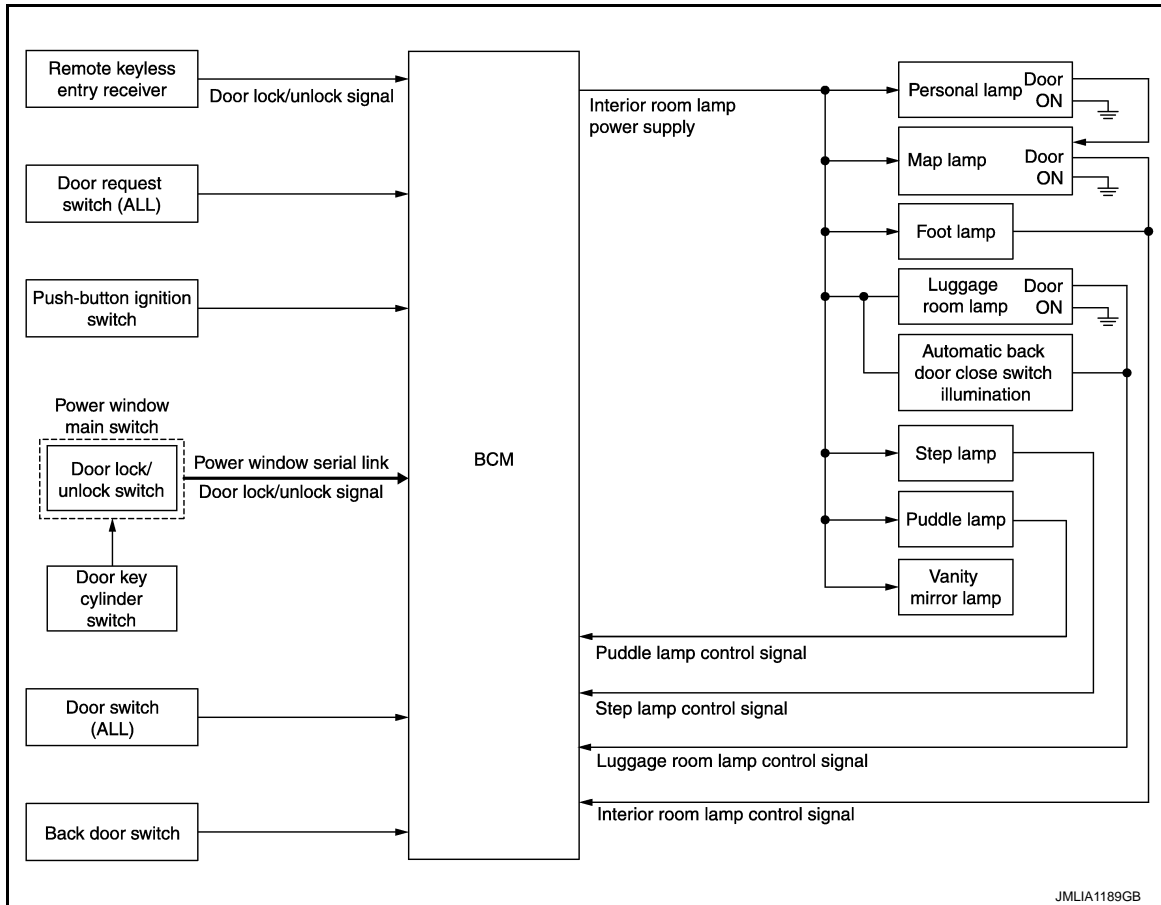

INTERIOR ROOM LAMP BATTERY SAVER SYSTEM : System Description

INFOID:000000009010358

OUTLINE

- Interior room lamp battery saver is controlled by BCM.
- BCM turns applicable lamps OFF depending on the vehicle condition. This function prevents the battery from over-discharging if the driver neglects turning OFF the any lamps.

Applicable lamps

- Map lamp
- Personal lamp
- Foot lamp
- Luggage room lamp
- Automatic back door close switch illumination
- Step lamp
- Puddle lamp
- Vanity mirror lamp

INTERIOR ROOM LAMP BATTERY SAVER FUNCTION

- When the ignition switch is turned to a position other than ON, BCM operates the timer for a period of time to cut the interior room lamp power supply.
- BCM restart the timer when any of the following signals changes while operating the timer.
 - Push-button ignition switch status
 - Door switch signal (ALL)
 - Door lock/unlock signal (remote keyless entry receiver, each door request switch, door lock and unlock switch, door key cylinder switch)
- BCM provides the interior room lamp power supply continuously when the ignition switch position is ON.
- When welcome light function operates.

NOTE:

SYSTEM

< SYSTEM DESCRIPTION >

Each function of interior room lamp battery saver can be set by CONSULT. Refer to [INL-15. "BATTERY SAVER : CONSULT Function \(BCM - BATTERY SAVER\)"](#).

ILLUMINATION CONTROL SYSTEM

ILLUMINATION CONTROL SYSTEM : System Diagram

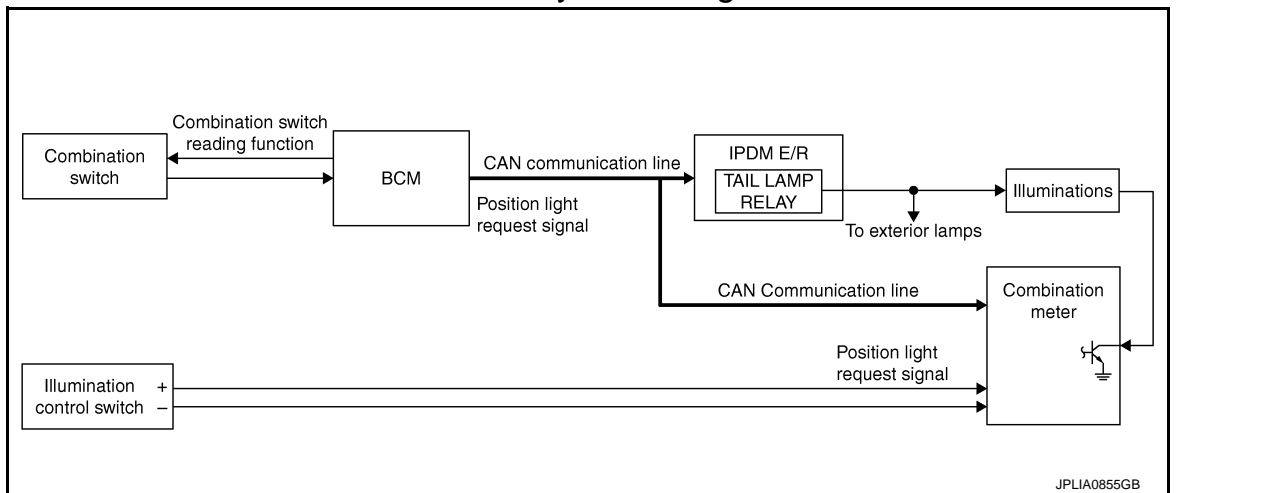

ILLUMINATION CONTROL SYSTEM : System Description

INFOID:000000009010360

OUTLINE

Each illumination lamp is controlled by each function of BCM, IPDM E/R and combination meter.

Control by BCM

- Combination switch reading function
- Headlamp control function

Control by IPDM E/R

- Relay control function

Control by combination meter

- Meter illumination control function (Refer to [MWI-17. "METER ILLUMINATION CONTROL : System Description"](#).)

ILLUMINATION CONTROL

- BCM detects the combination switch condition by the combination switch reading function.
- BCM transmits position light request signal to IPDM E/R and combination meter according to tail lamp ON condition.

Tail lamp ON condition

- Lighting switch 1ST
- Lighting switch 2ND
- Lighting switch AUTO, and the auto light function ON judgment
- Lighting switch AUTO, with the front fog lamp switch ON and the ignition switch ON
- IPDM E/R turns the integrated tail lamp relay ON according to position light request signal. It provides the power supply to each illumination lamp.
- Combination meter enters in the nighttime mode according to position light request signal. Under the nighttime mode the combination meter controls the illuminance by controlling each illumination lamp (ground side).

AUTO LIGHT ADJUSTMENT SYSTEM

SYSTEM

< SYSTEM DESCRIPTION >

AUTO LIGHT ADJUSTMENT SYSTEM : System Diagram

INFOID:000000009010361

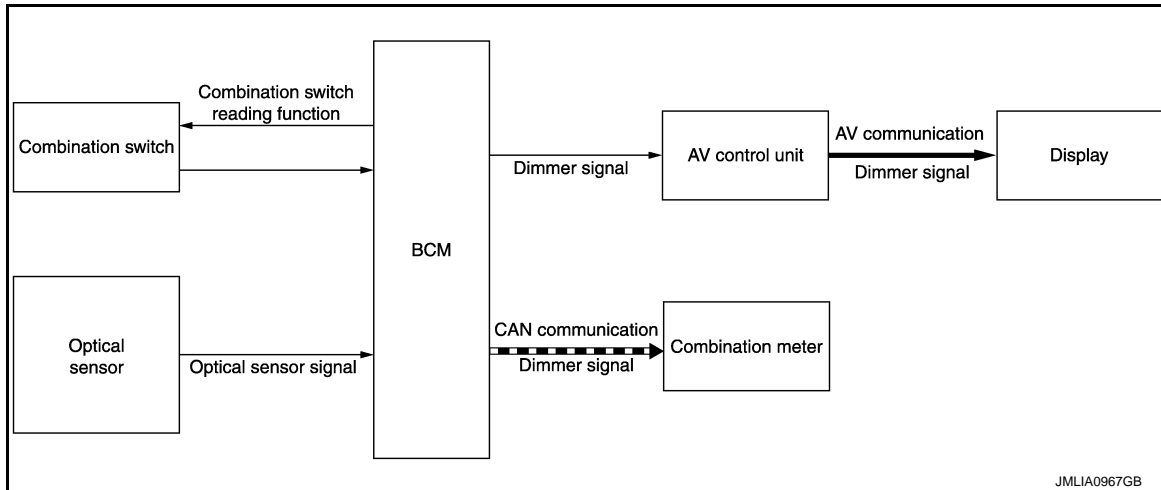

AUTO LIGHT ADJUSTMENT SYSTEM : System Description

INFOID:000000009010362

OUTLINE

Auto light adjustment system is controlled by each function of BCM, combination meter and AV control unit

Control by BCM

- Auto light system
- Auto light adjustment system

AUTO LIGHT ADJUSTMENT SYSTEM

Description

- BCM supplies voltage to the optical sensor when the ignition switch is turned ON or ACC.
- Optical sensor converts outside brightness (lux) to voltage and transmits the optical sensor signal to BCM.
- BCM judges dimming/brightening of combination meter and display according to brightness outside the vehicle, when ignition switch is ON.
- BCM transmits dimmer signal to combination meter via CAN communication, according to auto light adjustment conditions. Dimmer signal is also transmitted to AV control unit.

NOTE:

As to dimming/brightening timing, the sensitivity depends on settings. The settings can be changed with CONSULT. Refer to [EXL-22. "HEADLAMP : CONSULT Function \(BCM - HEAD LAMP\)"](#).

Auto Light Adjustment Timing Table

When the ignition switch is ON, the illumination of combination meter and display switches dimming/brightening in the following condition.

Combination meter and display	Dimming/brightening timing
Dimming	Outside brightness is 1250 lx or less for 3 seconds or more.
Brightening	Outside brightness is 2500 lx or more for 5 seconds or more.

BCM switches the illumination of combination meter and display to dimming when outside brightening obtained from the optical sensor signal is 1250 lx or less for 3 seconds or more. And BCM switches the illumination of combination meter and display to brightening when outside brightening from the optical sensor signal is 2500 lx or more for 5 seconds or more.

DIAGNOSIS SYSTEM (BCM)

< SYSTEM DESCRIPTION >

DIAGNOSIS SYSTEM (BCM)

COMMON ITEM

COMMON ITEM : CONSULT Function (BCM - COMMON ITEM)

INFOID:000000009336391

APPLICATION ITEM

CONSULT performs the following functions via CAN communication with BCM.

Diagnosis mode	Function Description
Work Support	Changes the setting for each system function.
Self Diagnostic Result	Displays the diagnosis results judged by BCM. Refer to BCS-57, "DTC Index" .
CAN Diag Support Monitor	Monitors the reception status of CAN communication viewed from BCM.
Data Monitor	The BCM input/output signals are displayed.
Active Test	The signals used to activate each device are forcibly supplied from BCM.
Ecu Identification	The BCM part number is displayed.
Configuration	<ul style="list-style-type: none"> • Read and save the vehicle specification. • Write the vehicle specification when replacing BCM.

SYSTEM APPLICATION

BCM can perform the following functions for each system.

NOTE:

It can perform the diagnosis modes except the following for all sub system selection items.

×: Applicable item

System	Sub system selection item	Diagnosis mode		
		Work Support	Data Monitor	Active Test
Door lock	DOOR LOCK	×	×	×
Rear window defogger	REAR DEFOGGER		×	×
Warning chime	BUZZER		×	×
Interior room lamp timer	INT LAMP	×	×	×
Exterior lamp	HEAD LAMP	×	×	×
Wiper and washer	WIPER	×	×	×
Turn signal and hazard warning lamps	FLASHER	×	×	×
—	AIR CONDITONER*		×	×
<ul style="list-style-type: none"> • Intelligent Key system • Engine start system 	INTELLIGENT KEY	×	×	×
Combination switch	COMB SW		×	
Body control system	BCM	×		
IVIS	IMMU	×	×	×
Interior room lamp battery saver	BATTERY SAVER	×	×	×
Back door	TRUNK		×	
Vehicle security system	THEFT ALM	×	×	×
RAP system	RETAINED PWR		×	
Signal buffer system	SIGNAL BUFFER		×	×
—	AIR PRESSURE MONITOR*	×	×	×

*: This item is indicated, but not used.

FREEZE FRAME DATA (FFD)

The BCM records the following vehicle condition at the time a particular DTC is detected, and displays on CONSULT.

DIAGNOSIS SYSTEM (BCM)

< SYSTEM DESCRIPTION >

CONSULT screen item	Indication/Unit	Description		
Vehicle Speed	km/h	Vehicle speed of the moment a particular DTC is detected		A
Odo/Trip Meter	km	Total mileage (Odometer value) of the moment a particular DTC is detected		
Vehicle Condition	SLEEP>LOCK	Power position status of the moment a particular DTC is detected	While turning BCM status from low power consumption mode to normal mode (Power supply position is "LOCK")	B
	SLEEP>OFF		While turning BCM status from low power consumption mode to normal mode (Power supply position is "OFF".)	C
	LOCK>ACC		While turning power supply position from "LOCK" to "ACC"	
	ACC>ON		While turning power supply position from "ACC" to "IGN"	D
	RUN>ACC		While turning power supply position from "RUN" to "ACC" (Vehicle is stopping and selector lever is except P position.)	
	CRANK>RUN		While turning power supply position from "CRANKING" to "RUN" (From cranking up the engine to run it)	E
	RUN>URGENT		While turning power supply position from "RUN" to "ACC" (Emergency stop operation)	
	ACC>OFF		While turning power supply position from "ACC" to "OFF"	F
	OFF>LOCK		While turning power supply position from "OFF" to "LOCK"	
	OFF>ACC		While turning power supply position from "OFF" to "ACC"	G
	ON>CRANK		While turning power supply position from "IGN" to "CRANKING"	
	OFF>SLEEP		While turning BCM status from normal mode (Power supply position is "OFF".) to low power consumption mode	H
	LOCK>SLEEP		While turning BCM status from normal mode (Power supply position is "LOCK".) to low power consumption mode	
	LOCK		Power supply position is "LOCK" (Ignition switch OFF with steering is locked.)	I
	OFF		Power supply position is "OFF" (Ignition switch OFF with steering is unlocked.)	J
	ACC		Power supply position is "ACC" (Ignition switch ACC)	
	ON		Power supply position is "IGN" (Ignition switch ON with engine stopped)	K
	ENGINE RUN		Power supply position is "RUN" (Ignition switch ON with engine running)	
CRANKING	Power supply position is "CRANKING" (At engine cranking)	INL		
IGN Counter	0 - 39	The number of times that ignition switch is turned ON after DTC is detected <ul style="list-style-type: none"> • The number is 0 when a malfunction is detected now. • The number increases like 1 → 2 → 3...38 → 39 after returning to the normal condition whenever ignition switch OFF → ON. • The number is fixed to 39 until the self-diagnosis results are erased if it is over 39. 		M

INT LAMP

DIAGNOSIS SYSTEM (BCM)

< SYSTEM DESCRIPTION >

INT LAMP : CONSULT Function (BCM - INT LAMP)

INFOID:000000009010364

WORK SUPPORT

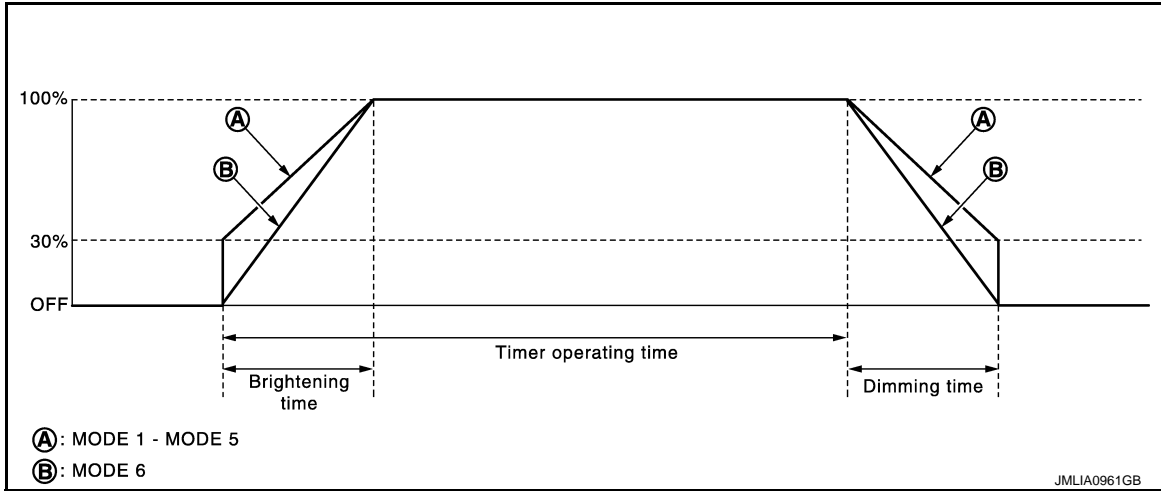

Service item	Setting item	Setting
SET I/L D-UNLCK INTCON	On*	With the interior room lamp timer function
	Off	Without the interior room lamp timer function
ROOM LAMP TIMER SET	MODE 2	7.5 sec.
	MODE 3*	15 sec.
	MODE 4	30 sec.
ROOM LAMP ON TIME SET	MODE 1	0.5 sec.
	MODE 2	1 sec.
	MODE 3	2 sec.
	MODE 4	3 sec.
	MODE 5	0 sec.
	MODE 6*	Gradually brightens from 0% to 100% brightness in 1 second.
ROOM LAMP OFF TIME SET	MODE 1	0.5 sec.
	MODE 2	1 sec.
	MODE 3	2 sec.
	MODE 4	3 sec.
	MODE 5	0 sec.
	MODE 6*	Gradually dims from 100% to 0% in 1 second.
R LAMP TIMER LOGIC SET	MODE 1*	Interior room lamp timer activates with synchronizing all doors.
	MODE 2	Interior room lamp timer activates with synchronizing the driver door only.

DATA MONITOR

NOTE:

The following table includes information (items) inapplicable to this vehicle. For information (items) applicable to this vehicle, refer to CONSULT display items.

Monitor item [Unit]	Description
REQ SW-DR [On/Off]	Indicated [On/Off] condition of door request switch (driver side)
REQ SW-AS [On/Off]	Indicated [On/Off] condition of door request switch (passenger side)

DIAGNOSIS SYSTEM (BCM)

< SYSTEM DESCRIPTION >

Monitor item [Unit]	Description
REQ SW-RR [On/Off]	NOTE: This item is displayed, but cannot be monitored
REQ SW-RL [On/Off]	NOTE: This item is displayed, but cannot be monitored
PUSH SW [On/Off]	Indicates [On/Off] condition of push-button ignition switch
UNLK SEN -DR [On/Off]	Indicates [On/Off] condition of driver door UNLOCK status
DOOR SW-DR [On/Off]	Indicated [On/Off] condition of front door switch (driver side)
DOOR SW-AS [On/Off]	Indicated [On/Off] condition of front door switch (passenger side)
DOOR SW-RR [On/Off]	Indicated [On/Off] condition of rear door switch RH
DOOR SW- RL [On/Off]	Indicated [On/Off] condition of rear door switch LH
DOOR SW- BK [On/Off]	Indicated [On/Off] condition of back door switch
CDL LOCK SW [On/Off]	Indicated [On/Off] condition of lock signal from door lock unlock switch
CDL UNLOCK SW [On/Off]	Indicated [On/Off] condition of unlock signal from door lock unlock switch
KEY CYL LK-SW [On/Off]	Indicated [On/Off] condition of lock signal from door key cylinder switch
KEY CYL UN-SW [On/Off]	Indicated [On/Off] condition of unlock signal from door key cylinder switch
TRNK/HAT MNTR [On/Off]	NOTE: This item is displayed, but cannot be monitored
RKE-LOCK [On/Off]	Indicates [On/Off] condition of LOCK signal from Intelligent Key
RKE-UNLOCK [On/Off]	Indicates [On/Off] condition of UNLOCK signal from Intelligent Key

ACTIVE TEST

Test item	Operation	Description
INT LAMP	On	Outputs the interior room lamp control signal.
	Off	Stops the interior room lamp control signal.
STEP LAMP TEST	On	Outputs the step lamp control signal.
	Off	Stops the step lamp control signal.

BATTERY SAVER

BATTERY SAVER : CONSULT Function (BCM - BATTERY SAVER)

INFOID:000000009010365

WORK SUPPORT

Service item	Setting item	Setting
ROOM LAMP TIMER SET	MODE 1	30 min.
	MODE 2	60 min.
	MODE 3*	15 min.
		Sets the interior room lamp battery saver timer operating time.

DIAGNOSIS SYSTEM (BCM)

< SYSTEM DESCRIPTION >

Service item	Setting item	Setting
BATTERY SAVER SET	On*	With the exterior lamp battery saver function
	Off	Without the exterior lamp battery saver function

*:Factory setting

DATA MONITOR

NOTE:

The following table includes information (items) inapplicable to this vehicle. For information (items) applicable to this vehicle, refer to CONSULT display items.

Monitor item [Unit]	Description
REQ SW-DR [On/Off]	Indicated [On/Off] condition of door request switch (driver side)
REQ SW-AS [On/Off]	Indicated [On/Off] condition of door request switch (passenger side)
REQ SW-RR [On/Off]	NOTE: This item is displayed, but cannot be monitored
REQ SW-RL [On/Off]	NOTE: This item is displayed, but cannot be monitored
PUSH SW [On/Off]	Indicates [On/Off] condition of push-button ignition switch
UNLK SEN -DR [On/Off]	Indicates [On/Off] condition of driver door UNLOCK status
DOOR SW-DR [On/Off]	Indicated [On/Off] condition of front door switch (driver side)
DOOR SW-AS [On/Off]	Indicated [On/Off] condition of front door switch (passenger side)
DOOR SW-RR [On/Off]	Indicated [On/Off] condition of rear door switch RH
DOOR SW- RL [On/Off]	Indicated [On/Off] condition of rear door switch LH
DOOR SW- BK [On/Off]	Indicated [On/Off] condition of back door switch
CDL LOCK SW [On/Off]	Indicated [On/Off] condition of lock signal from door lock unlock switch
CDL UNLOCK SW [On/Off]	Indicated [On/Off] condition of unlock signal from door lock unlock switch
KEY CYL LK-SW [On/Off]	Indicated [On/Off] condition of lock signal from door key cylinder switch
KEY CYL UN-SW [On/Off]	Indicated [On/Off] condition of unlock signal from door key cylinder switch
TRNK/HAT MNTR [On/Off]	NOTE: This item is displayed, but cannot be monitored
RKE-LOCK [On/Off]	Indicates [On/Off] condition of LOCK signal from Intelligent Key
RKE-UNLOCK [On/Off]	Indicates [On/Off] condition of UNLOCK signal from Intelligent Key

ACTIVE TEST

Test item	Operation	Description
BATTERY SAVER	Off	Cuts the interior room lamp power supply.
	On	Outputs the interior room lamp power supply.

BCM

< ECU DIAGNOSIS INFORMATION >

ECU DIAGNOSIS INFORMATION

BCM

List of ECU Reference

INFOID:000000009010366

ECU	Reference
	BCS-35, "Reference Value"
BCM	BCS-56, "Fail-safe"
	BCS-57, "DTC Inspection Priority Chart"
	BCS-57, "DTC Index"

A

B

C

D

E

F

G

H

I

J

K

INL

M

N

O

P

INTERIOR ROOM LAMP CONTROL SYSTEM

< WIRING DIAGRAM >

WIRING DIAGRAM

INTERIOR ROOM LAMP CONTROL SYSTEM

Wiring Diagram

INFOID:000000009010367

For connector terminal arrangements, harness layouts, and alphabets in a  (option abbreviation; if not described in wiring diagram), refer to [GI-12. "Connector Information"](#).

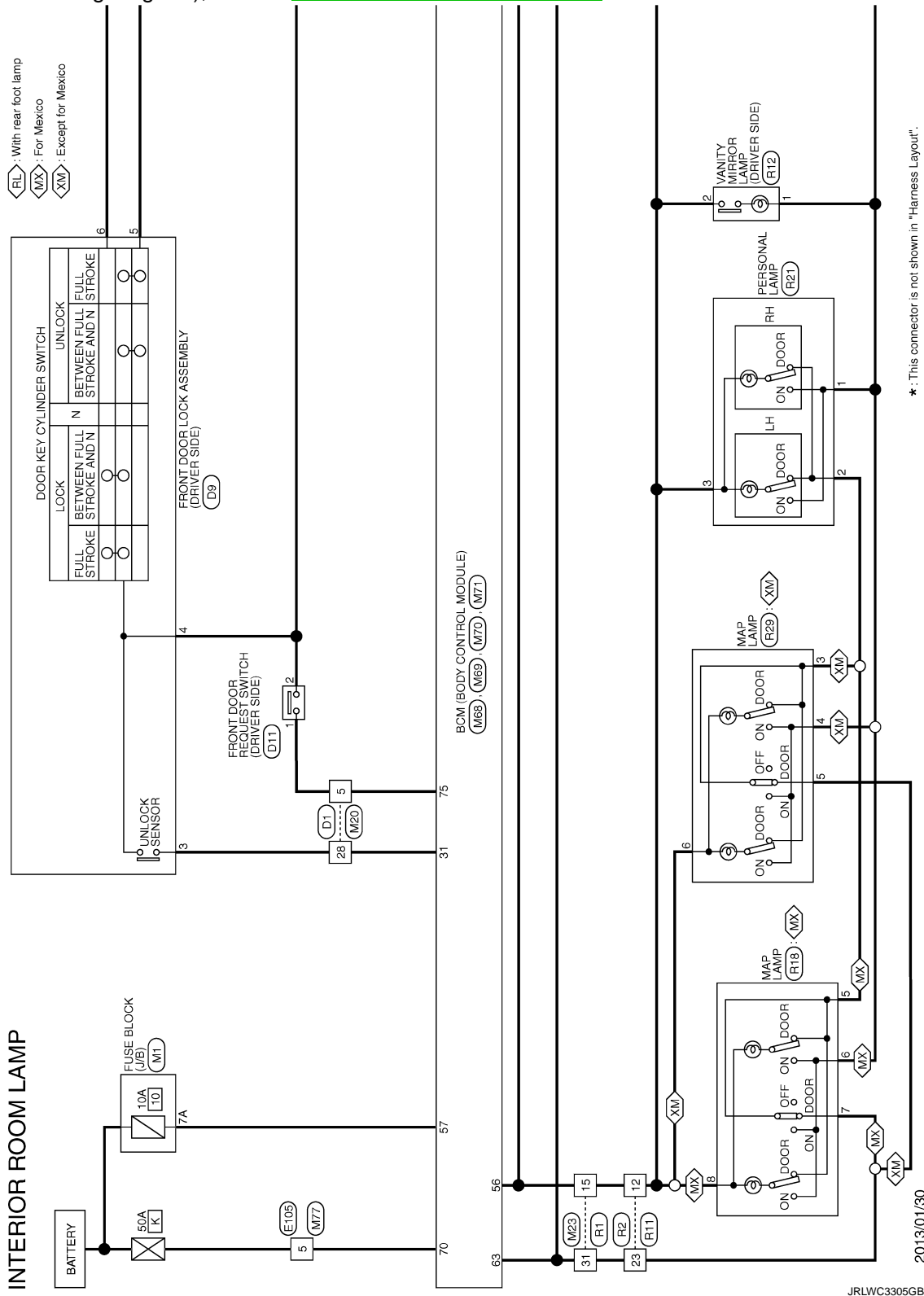

INTERIOR ROOM LAMP CONTROL SYSTEM

< WIRING DIAGRAM >

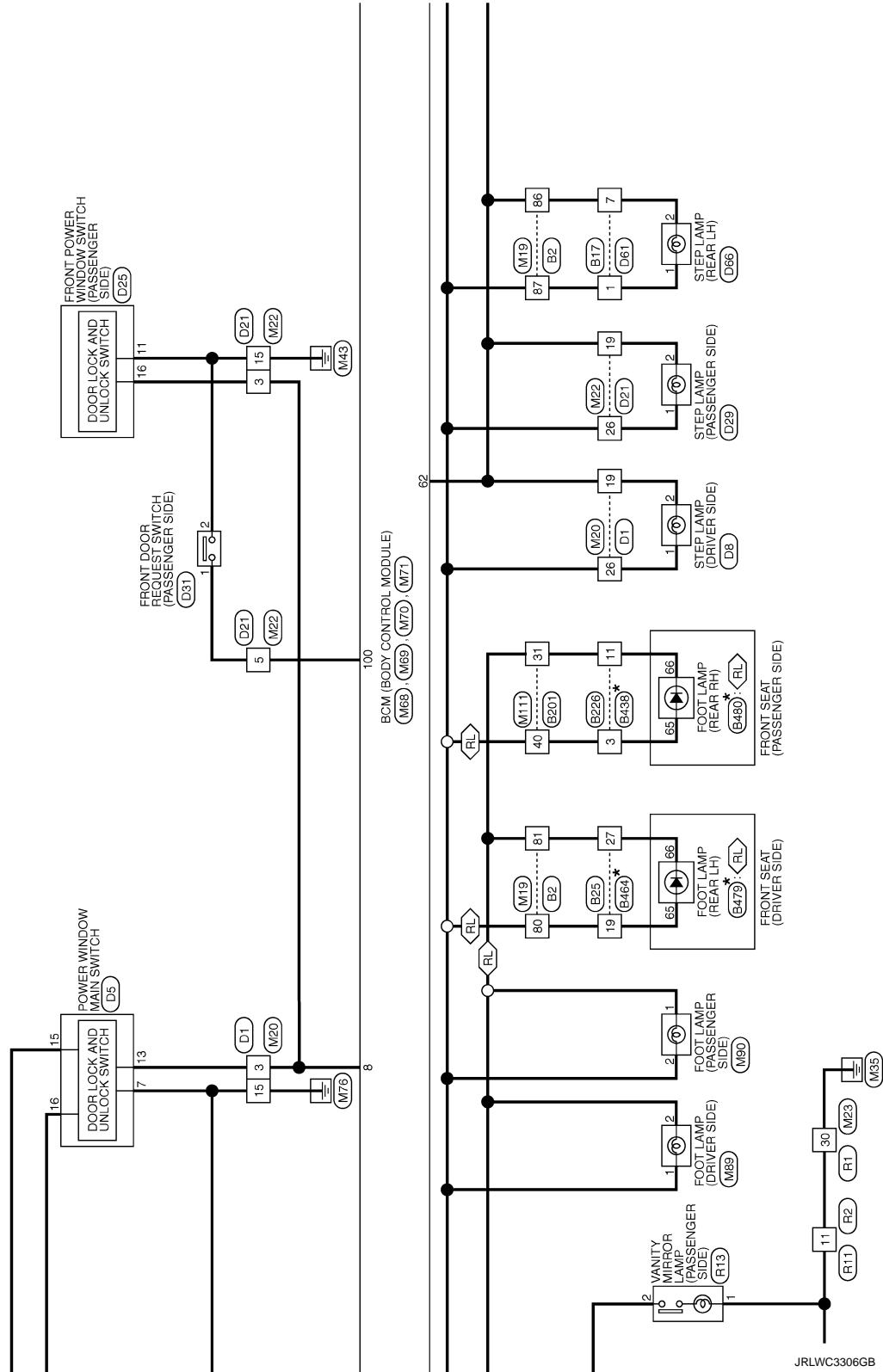

A
B
C
D
E
F
G
H
I
J
K
L
M
N
O
P

INL

INTERIOR ROOM LAMP CONTROL SYSTEM

< WIRING DIAGRAM >

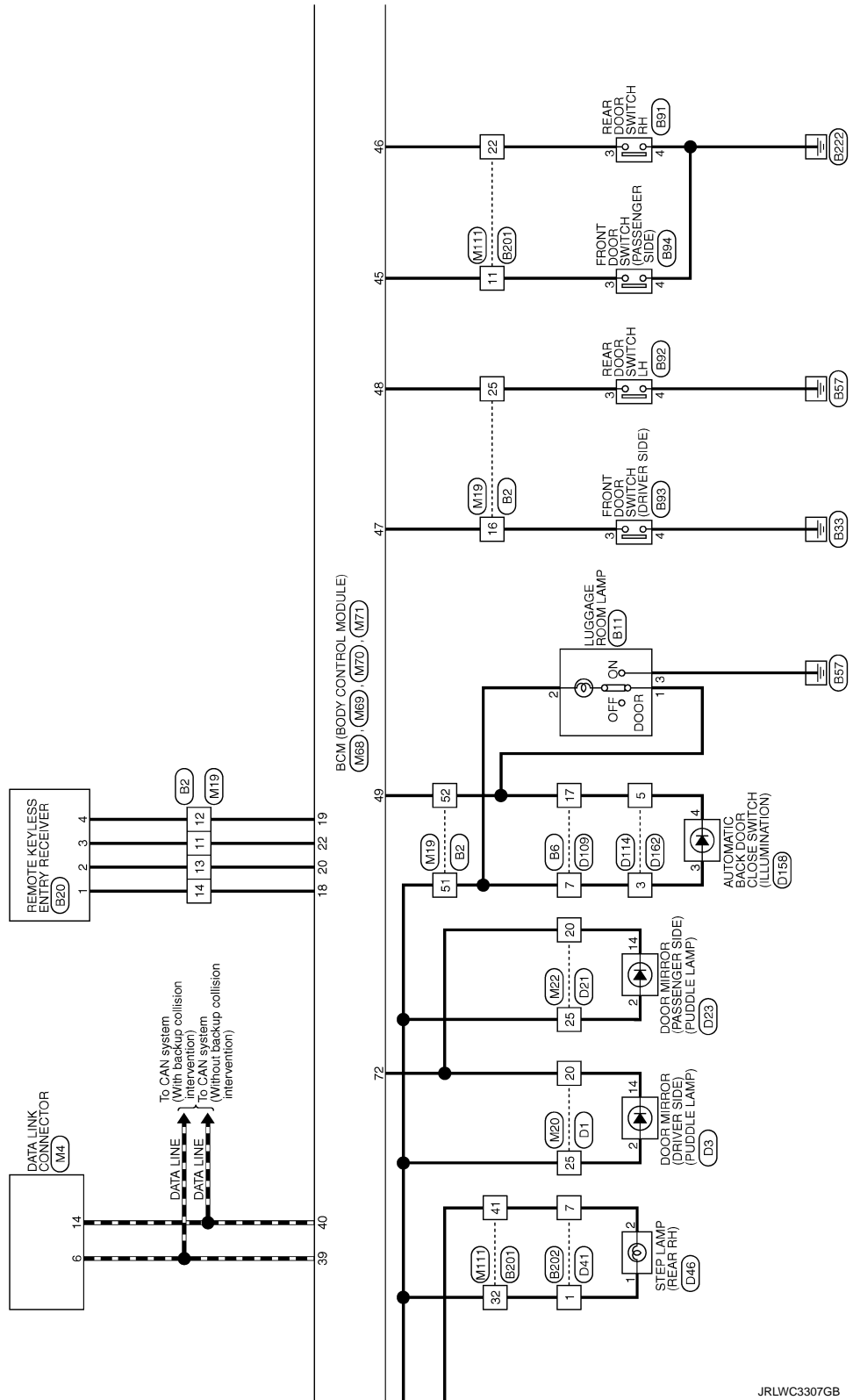

JRLWC3307GB

INTERIOR ROOM LAMP CONTROL SYSTEM

< WIRING DIAGRAM >

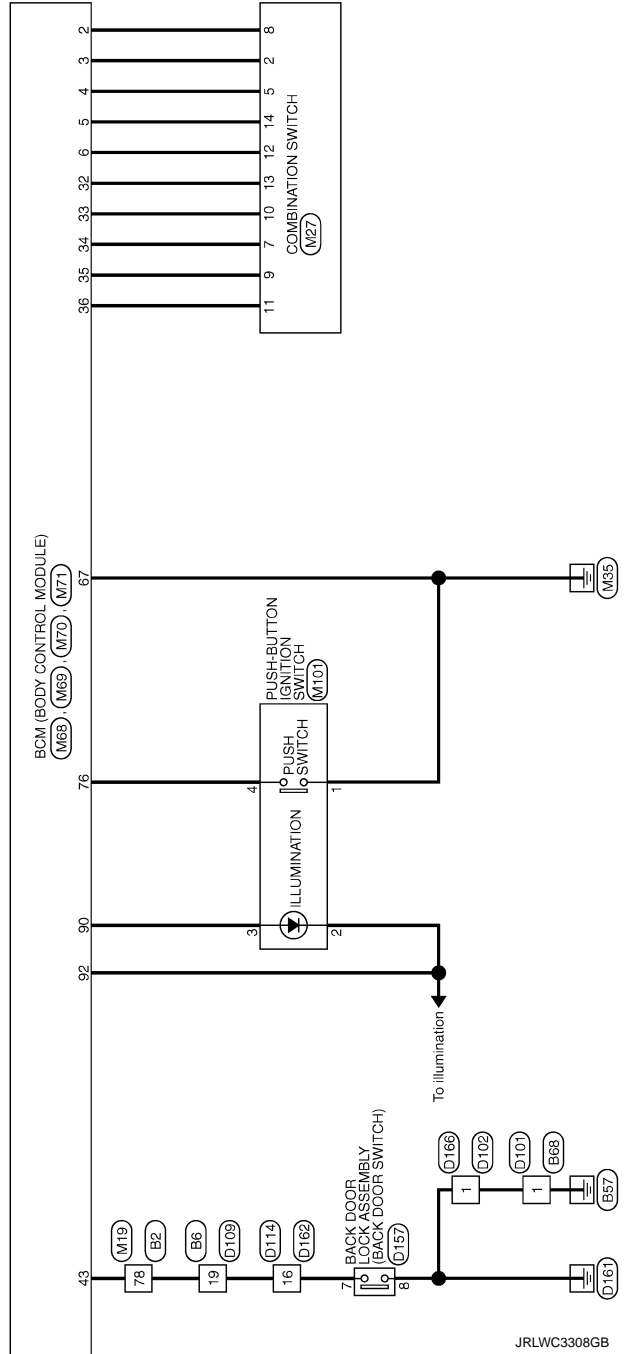

A
B
C
D
E
F
G
H
I
J
K
INL
M
N
O
P

ILLUMINATION

< WIRING DIAGRAM >

ILLUMINATION

Wiring Diagram

INFOID:000000009010368

For connector terminal arrangements, harness layouts, and alphabets in a  (option abbreviation; if not described in wiring diagram), refer to [GI-12, "Connector Information"](#).

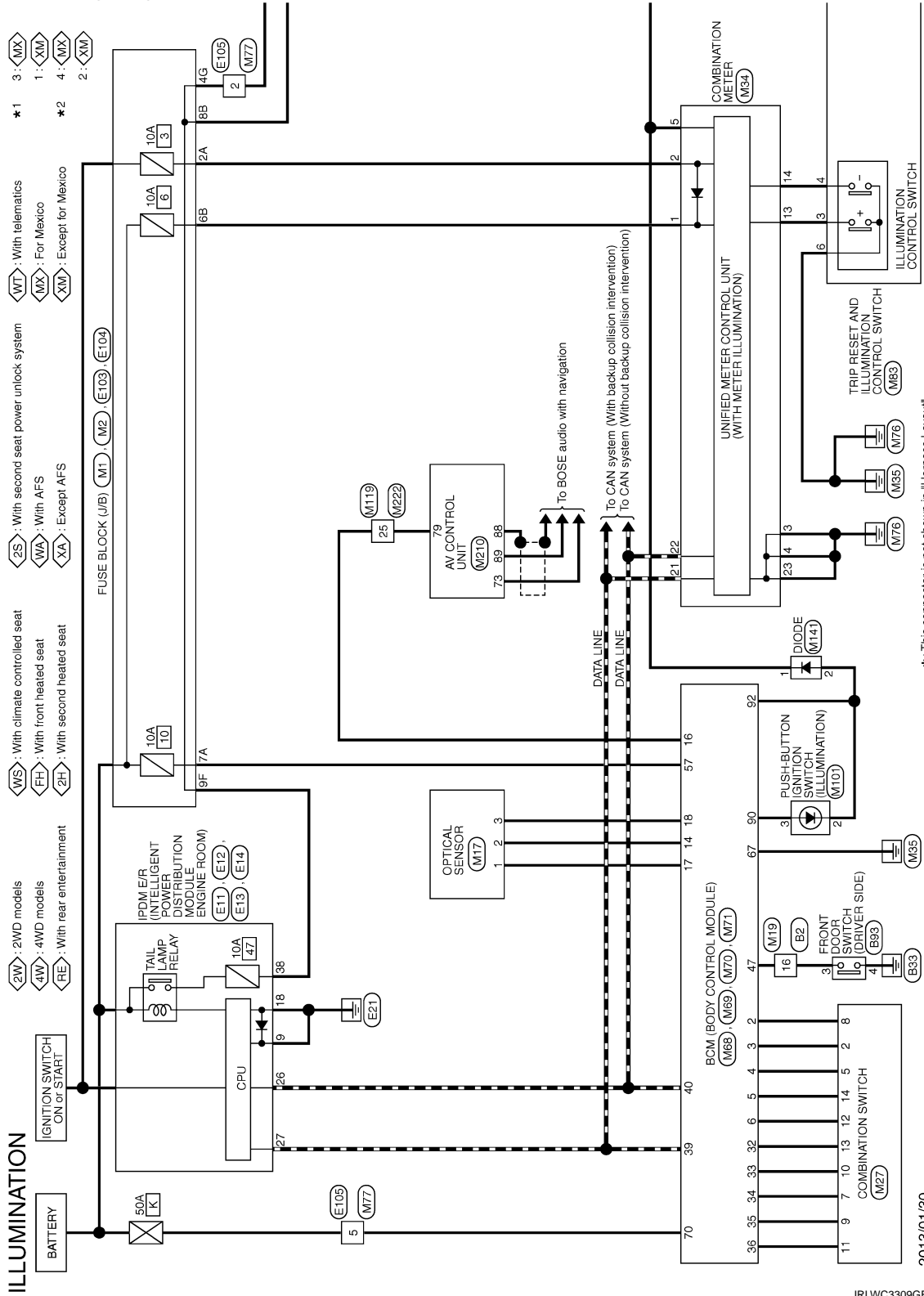

ILLUMINATION

< WIRING DIAGRAM >

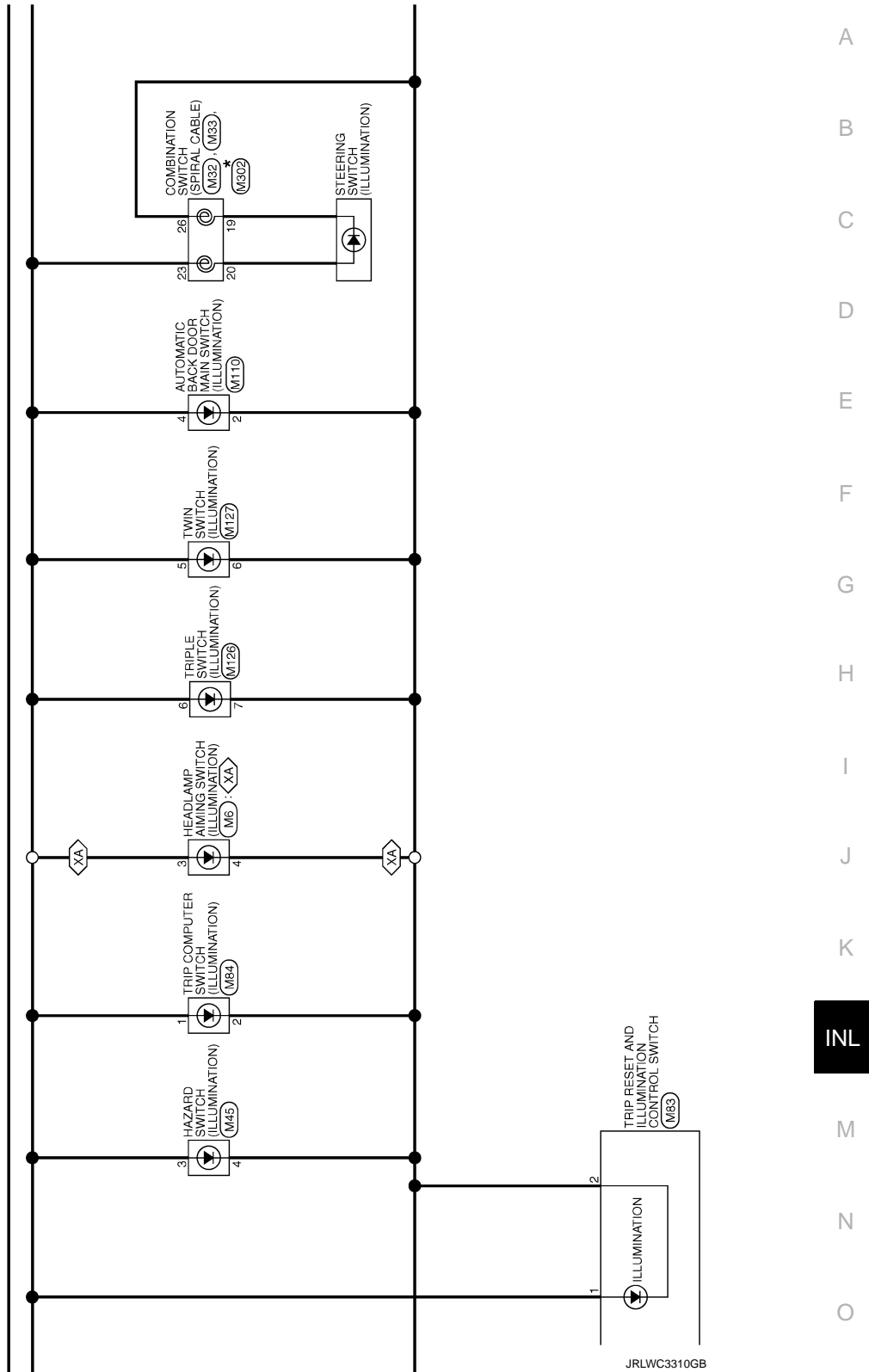

A
B
C
D
E
F
G
H
I
J
K
INL
M
N
O
P

ILLUMINATION

< WIRING DIAGRAM >

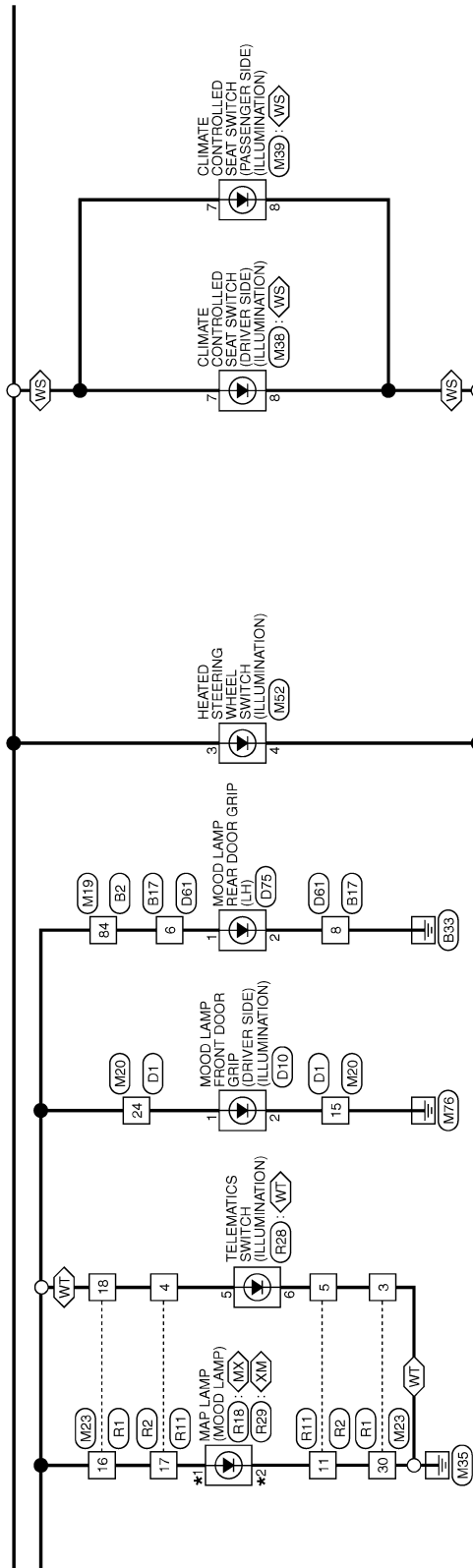

JRLWC3311GB

ILLUMINATION

< WIRING DIAGRAM >

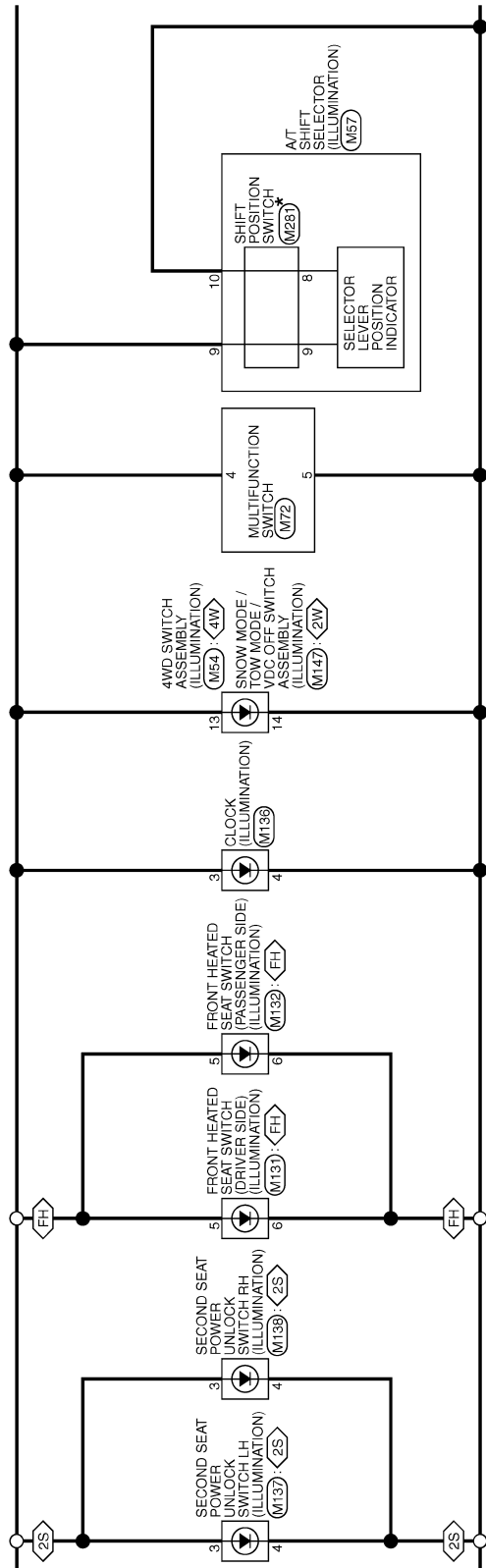

JRLWC3312GB

A
B
C
D
E
F
G
H
I
J
K
INL
M
N
O
P

ILLUMINATION

< WIRING DIAGRAM >

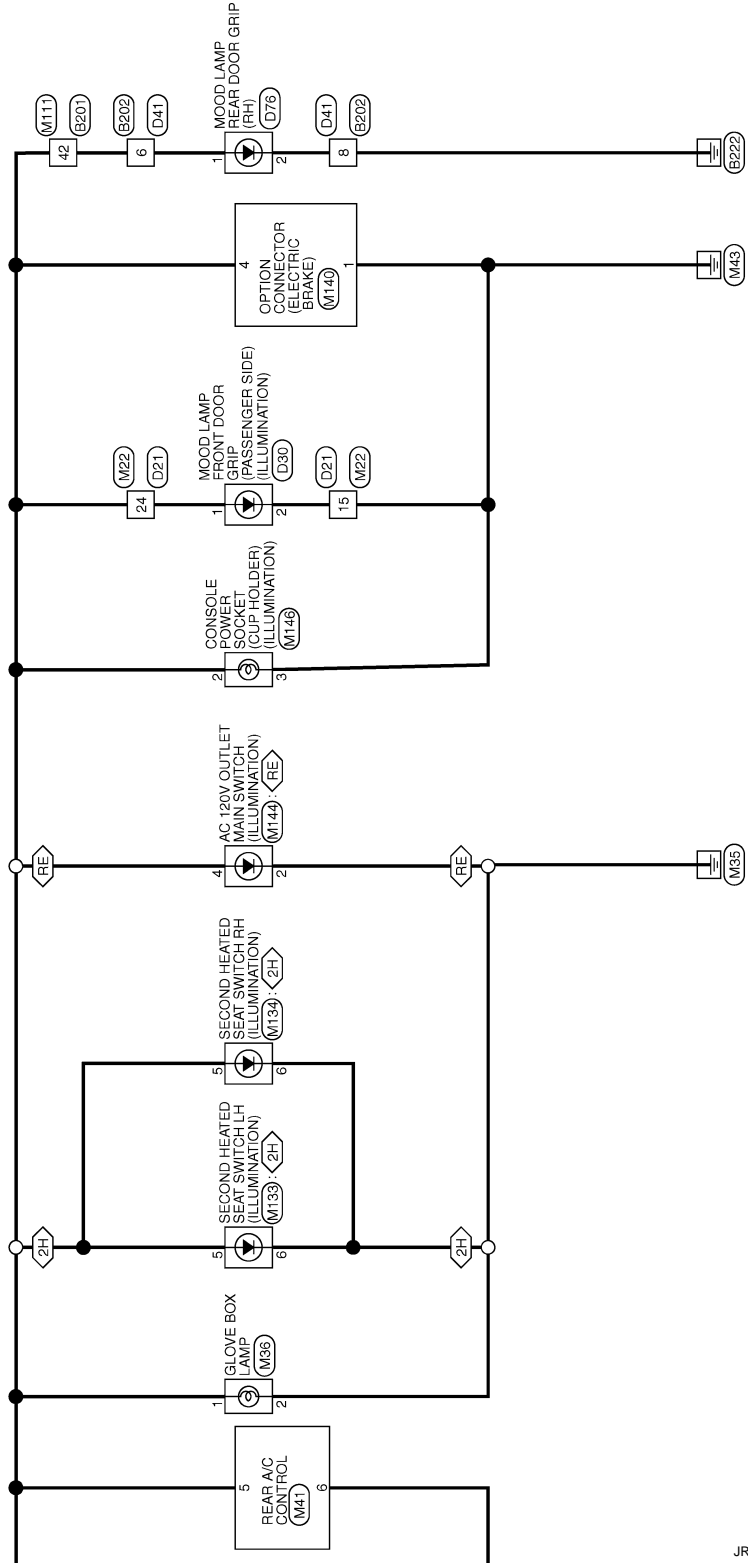

JRLWC3313GB

DIAGNOSIS AND REPAIR WORK FLOW

< BASIC INSPECTION >

BASIC INSPECTION

DIAGNOSIS AND REPAIR WORK FLOW

Work Flow

INFOID:000000009010369

OVERALL SEQUENCE

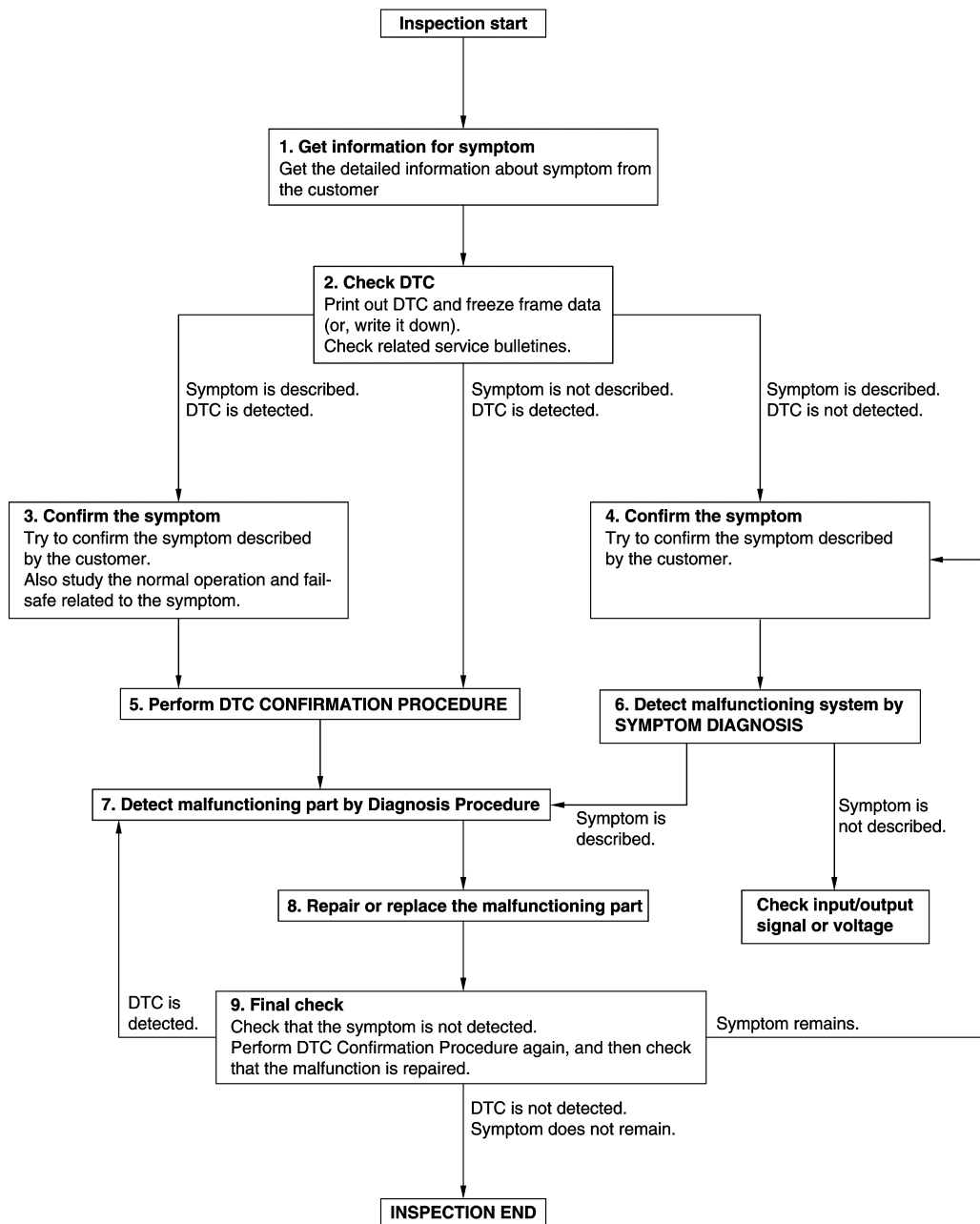

DETAILED FLOW

JMKIA8652GB

DIAGNOSIS AND REPAIR WORK FLOW

< BASIC INSPECTION >

1. GET INFORMATION FOR SYMPTOM

1. Get detailed information from the customer about the symptom (the condition and the environment when the incident/malfunction occurs).
2. Check operation condition of the function that is malfunctioning.

>> GO TO 2.

2. CHECK DTC

1. Check DTC.
2. Perform the following procedure if DTC is detected.
 - Record DTC and freeze frame data (Print them out using CONSULT.)
 - Erase DTC.
 - Study the relationship between the cause detected by DTC and the symptom described by the customer.
3. Check related service bulletins for information.

Are any symptoms described and any DTC detected?

Symptom is described, DTC is detected>>GO TO 3.

Symptom is described, DTC is not detected>>GO TO 4.

Symptom is not described, DTC is detected>>GO TO 5.

3. CONFIRM THE SYMPTOM

Try to confirm the symptom described by the customer.

Also study the normal operation and fail-safe related to the symptom.

Verify relation between the symptom and the condition when the symptom is detected.

>> GO TO 5.

4. CONFIRM THE SYMPTOM

Try to confirm the symptom described by the customer.

Verify relation between the symptom and the condition when the symptom is detected.

>> GO TO 6.

5. PERFORM DTC CONFIRMATION PROCEDURE

Perform DTC CONFIRMATION PROCEDURE for the detected DTC, and then check that DTC is detected again. At this time, always connect CONSULT to the vehicle, and check self diagnostic results in real time. If two or more DTCs are detected, refer to DTC INSPECTION PRIORITY CHART, and determine trouble diagnosis order.

NOTE:

- Freeze frame data is useful if the DTC is not detected.
- Perform Component Function Check if DTC CONFIRMATION PROCEDURE is not included on Service Manual. This simplified check procedure is an effective alternative though DTC cannot be detected during this check.
If the result of Component Function Check is NG, it is the same as the detection of DTC by DTC CONFIRMATION PROCEDURE.

Is DTC detected?

YES >> GO TO 7.

NO >> Check according to [GI-43. "Intermittent Incident"](#).

6. DETECT MALFUNCTIONING SYSTEM BY SYMPTOM DIAGNOSIS

Detect malfunctioning system according to SYMPTOM DIAGNOSIS based on the confirmed symptom in step 4, and determine the trouble diagnosis order based on possible causes and symptom.

Is the symptom described?

YES >> GO TO 7.

NO >> Monitor input data from related sensors or check voltage of related module terminals using CONSULT.

7. DETECT MALFUNCTIONING PART BY DIAGNOSIS PROCEDURE

DIAGNOSIS AND REPAIR WORK FLOW

< BASIC INSPECTION >

Inspect according to Diagnosis Procedure of the system.

Is malfunctioning part detected?

YES >> GO TO 8.

NO >> Check according to [GI-43. "Intermittent Incident"](#).

8. REPAIR OR REPLACE THE MALFUNCTIONING PART

1. Repair or replace the malfunctioning part.
2. Reconnect parts or connectors disconnected during Diagnosis Procedure again after repair and replacement.
3. Check DTC. If DTC is detected, erase it.

>> GO TO 9.

9. FINAL CHECK

When DTC is detected in step 2, perform DTC CONFIRMATION PROCEDURE again, and then check that the malfunction is repaired securely.

When symptom is described by the customer, refer to confirmed symptom in step 3 or 4, and check that the symptom is not detected.

Is DTC detected and does symptom remain?

YES-1 >> DTC is detected: GO TO 7.

YES-2 >> Symptom remains: GO TO 4.

NO >> Before returning the vehicle to the customer, always erase DTC.

A
B
C
D
E
F
G
H
I
J
K
INL
M
N
O
P

INTERIOR ROOM LAMP POWER SUPPLY CIRCUIT

< DTC/CIRCUIT DIAGNOSIS >

DTC/CIRCUIT DIAGNOSIS

INTERIOR ROOM LAMP POWER SUPPLY CIRCUIT

Description

INFOID:000000009010370

Provides the interior room lamp power supply. Also cuts the power supply when the interior room lamp battery saver activating.

Component Function Check

INFOID:000000009010371

1. CHECK INTERIOR ROOM LAMP POWER SUPPLY FUNCTION

ⓅCONSULT ACTIVE TEST

1. Turn ignition switch ON.
2. Turn each interior room lamp ON.
 - Personal lamp
 - Map lamp
 - Foot lamp
 - Luggage room lamp
 - Automatic back door close switch illumination
 - Step lamp
 - Puddle lamp
 - Vanity mirror lamp
3. Select "BATTERY SAVER" of BCM (BATTERY SAVER) active test item.
4. With operating the test items, check that each interior room lamp turns ON/OFF.

Off : Interior room lamp OFF

On : Interior room lamp ON

Does the interior room lamp turn ON/OFF?

YES >> Interior room lamp power supply circuit is normal.

NO >> Refer to [INL-30, "Diagnosis Procedure"](#).

Diagnosis Procedure

INFOID:000000009010372

1. CHECK INTERIOR ROOM LAMP POWER SUPPLY OUTPUT

ⓅCONSULT ACTIVE TEST

1. Turn ignition switch OFF.
2. Disconnect the following connectors.
 - Personal lamp
 - Map lamp
 - Foot lamp (both sides)
 - Luggage room lamp
 - Automatic back door close switch illumination
 - Step lamp (ALL)
 - Puddle lamp (both sides)
 - Vanity mirror lamp (both sides)
3. Turn ignition switch ON.
4. Select "BATTERY SAVER" of BCM (BATTERY SAVER) active test item.
5. With operating the test item, check voltage between BCM harness connector and ground.

BCM		(-)	Test item	Voltage (Approx.)	
(+) Connector Terminal					
M70	56	Ground	BATTERY SAVER	Off	0 V
			BATTERY SAVER	On	12 V

Is the inspection result normal?

INTERIOR ROOM LAMP POWER SUPPLY CIRCUIT

< DTC/CIRCUIT DIAGNOSIS >

- YES >> GO TO 2.
 NO >> GO TO 3.

2. CHECK INTERIOR ROOM LAMP POWER SUPPLY OPEN CIRCUIT

1. Turn ignition switch OFF.
2. Disconnect the BCM connector.
3. Check continuity between BCM harness connector and each interior room lamp harness connector.

For Mexico

BCM		Each interior room lamp		Continuity	
Connector	Terminal	Connector	Terminal		
M70	56	Personal lamp	R21	3	Existed
		Map lamp	R18	8	
		Foot lamp (driver side)	M89	1	
		Foot lamp (passenger side)	M90	2	
		Luggage room lamp	B11	2	
		Automatic back door close switch	D158	3	
		Step lamp (driver side)	D8	1	
		Step lamp (passenger side)	D29	1	
		Step lamp (Rear LH)	D66	1	
		Step lamp (Rear RH)	D46	1	
		Puddle lamp (driver side)	D3	2	
		Puddle lamp (passenger side)	D23	2	
		Vanity mirror lamp (driver side)	R12	2	
		Vanity mirror lamp (passenger side)	R13	2	
		Foot lamp (Rear LH)	B479	65	
Foot lamp (Rear RH)	B480	65			

A
B
C
D
E
F
G
H
I
J
K
L
M
N
O
P

INL

INTERIOR ROOM LAMP POWER SUPPLY CIRCUIT

< DTC/CIRCUIT DIAGNOSIS >

Except for Mexico

BCM		Each interior room lamp			Continuity
Connector	Terminal	Connector	Terminal	Terminal	
M70	56	Personal lamp	R21	3	Existed
		Map lamp	R29	6	
		Foot lamp (driver side)	M89	1	
		Foot lamp (passenger side)	M90	2	
		Luggage room lamp	B11	2	
		Automatic back door close switch	D158	3	
		Step lamp (driver side)	D8	1	
		Step lamp (passenger side)	D29	1	
		Step lamp (Rear LH)	D66	1	
		Step lamp (Rear RH)	D46	1	
		Puddle lamp (driver side)	D3	2	
		Puddle lamp (passenger side)	D23	2	
		Vanity mirror lamp (driver side)	R12	2	
		Vanity mirror lamp (passenger side)	R13	2	
		Foot lamp (Rear LH)	B479	65	
Foot lamp (Rear RH)	B480	65			

Is the inspection result normal?

YES >> Check for internal short circuit of each interior room lamp.

NO >> Repair or replace harnesses.

3. CHECK INTERIOR ROOM LAMP POWER SUPPLY SHORT CIRCUIT

1. Turn ignition switch OFF.
2. Disconnect the BCM connector.
3. Check continuity between BCM harness connector and ground.

BCM		Ground	Continuity
Connector	Terminal		
M70	56		Not existed

Is the inspection result normal?

YES >> Replace BCM. Refer to [BCS-82, "Removal and Installation"](#).

NO >> Repair or replace harnesses.

INTERIOR ROOM LAMP CONTROL CIRCUIT

< DTC/CIRCUIT DIAGNOSIS >

INTERIOR ROOM LAMP CONTROL CIRCUIT

Description

INFOID:000000009010373

Controls each interior room lamp (ground side) by PWM signal.

NOTE:

PWM signal control period is approximately 250 Hz (in the gradual brightening/dimming).

Component Function Check

INFOID:000000009010374

NOTE:

Before performing the diagnosis, check that the following are normal.

- Interior room lamp power supply
- Map lamp bulb
- Personal lamp bulb
- Foot lamp bulb

1. CHECK INTERIOR ROOM LAMP CONTROL FUNCTION

ⓐ CONSULT ACTIVE TEST

1. Switch the map lamp switch and personal lamp switch to DOOR.
2. Turn ignition switch ON.
3. Select "INT LAMP" of BCM (INT LAMP) active test item.
4. With operating the test items, check that each interior room lamp turns ON/OFF (gradual brightening/dimming).

On : Interior room lamp gradual brightening

Off : Interior room lamp gradual dimming

Does the interior room lamp turns ON/OFF (gradual brightening/dimming)?

YES >> Interior room lamp control circuit is normal.

NO >> Refer to [INL-33, "Diagnosis Procedure"](#).

Diagnosis Procedure

INFOID:000000009010375

1. CHECK INTERIOR ROOM LAMP CONTROL OUTPUT

ⓐ CONSULT ACTIVE TEST

1. Switch the map lamp switch and personal lamp switch to DOOR.
2. Turn ignition switch OFF.
3. Remove all the bulbs of map lamp, foot lamp and personal lamp.
4. Turn ignition switch ON.
5. Select "INT LAMP" of BCM (INT LAMP) active test item.
6. With operating the test item, check continuity between BCM harness connector and ground.

BCM		Ground	Test item		Continuity
Connector	Terminal		INT LAMP	On	Existed
M70	63			On	Existed
			Off	Not existed	

Is the inspection result normal?

YES >> GO TO 2.

NO-1 >> Continuity exists and remains unchanged: GO TO 3.

NO-2 >> Continuity does not exist and remains unchanged: Replace BCM. Refer to [BCS-82, "Removal and Installation"](#).

2. CHECK INTERIOR ROOM LAMP CONTROL OPEN CIRCUIT

1. Turn ignition switch OFF.
2. Disconnect BCM connector, map lamp connector, personal lamp connector and foot lamp connector.
3. Check continuity between BCM harness connector and foot lamp harness connector.

INTERIOR ROOM LAMP CONTROL CIRCUIT

< DTC/CIRCUIT DIAGNOSIS >

BCM		Foot lamp			Continuity
Connector	Terminal	Connector		Terminal	
M70	63	Driver side	M89	2	Existed
		Passenger side	M90	1	
		Rear LH	B479	66	
		Rear RH	B480		

4. Check continuity between BCM harness connector and map lamp harness connector.

For Mexico

BCM		Map lamp		Continuity
Connector	Terminal	Connector	Terminal	
M70	63	R18	7	Existed

Except for Mexico

BCM		Map lamp		Continuity
Connector	Terminal	Connector	Terminal	
M70	63	R29	5	Existed

5. Check continuity between personal lamp harness connector and map lamp harness connector.

For Mexico

Personal lamp		Map lamp		Continuity
Connector	Terminal	Connector	Terminal	
R21	2	R18	5	Existed

Except for Mexico

Personal lamp		Map lamp		Continuity
Connector	Terminal	Connector	Terminal	
R21	2	R29	3	Existed

Is the inspection result normal?

YES >> Replace map lamp, personal lamp or foot lamp.

NO >> Repair or replace harnesses.

3. CHECK INTERIOR ROOM LAMP CONTROL SHORT CIRCUIT

- Turn ignition switch OFF.
- Disconnect BCM connector, map lamp connector, personal lamp connector and foot lamp connector.
- Check continuity between BCM harness connector and ground.

BCM		Ground	Continuity
Connector	Terminal		
M70	63		Not existed

4. Check continuity between personal lamp harness connector and ground.

Personal lamp		Ground	Continuity
Connector	Terminal		
R21	2		Not existed

Is the inspection result normal?

YES >> Replace BCM. Refer to [BCS-82, "Removal and Installation"](#).

NO >> Repair or replace harnesses.

LUGGAGE ROOM LAMP CIRCUIT

< DTC/CIRCUIT DIAGNOSIS >

LUGGAGE ROOM LAMP CIRCUIT

Description

INFOID:000000009010376

Controls the luggage room lamp and automatic back door close switch illumination (ground side) to turn the luggage room lamp and automatic back door close switch illumination ON and OFF.

Diagnosis Procedure

INFOID:000000009010377

NOTE:

Before performing the diagnosis, check that the following are normal.

- Interior room lamp power supply
- Luggage room lamp bulb

1.CHECK LUGGAGE ROOM LAMP OUTPUT

1. Turn ignition switch OFF.
2. Remove the luggage room bulb.
3. Disconnect automatic back door close switch connector.
4. Check continuity between BCM harness connector and ground.

BCM		Ground	Condition		Continuity
Connector	Terminal		Back door	Open	Existed
M69	49			Closed	Not existed

Is the inspection result normal?

YES >> GO TO 2.

NO-1 >> Continuity exists and remains unchanged: GO TO 3.

NO-2 >> Continuity does not exist and remains unchanged: Replace BCM. Refer to [BCS-82, "Removal and Installation"](#).

2.CHECK LUGGAGE ROOM LAMP OPEN CIRCUIT

1. Disconnect BCM connector.
2. Check continuity between BCM harness connector and luggage room lamp harness connector.

BCM		Luggage room lamp		Continuity
Connector	Terminal	Connector	Terminal	
M69	49	B11	1	Existed

3. Check continuity between BCM harness connector and automatic back door close switch harness connector.

BCM		Automatic back door close switch		Continuity
Connector	Terminal	Connector	Terminal	
M69	49	D158	4	Existed

Is the inspection result normal?

YES >> Replace luggage room lamp or automatic back door close switch.

NO >> Repair or replace harnesses.

3.CHECK LUGGAGE ROOM LAMP SHORT CIRCUIT

1. Disconnect BCM connector.
2. Check continuity between BCM harness connector and ground.

BCM		Ground	Continuity
Connector	Terminal		Not existed
M69	49		

Is the inspection result normal?

LUGGAGE ROOM LAMP CIRCUIT

< DTC/CIRCUIT DIAGNOSIS >

- YES >> Replace BCM. Refer to [BCS-82. "Removal and Installation"](#).
- NO >> Repair or replace harnesses.

STEP LAMP CIRCUIT

< DTC/CIRCUIT DIAGNOSIS >

STEP LAMP CIRCUIT

Description

INFOID:000000009010378

Controls the step lamp (ground side) to turn the step lamp ON and OFF.

Component Function Check

INFOID:000000009010379

NOTE:

Before performing the diagnosis, check that the following is normal.

- Interior room lamp power supply
- Step lamp bulb

1.CHECK STEP LAMP OPERATION

CONSULT ACTIVE TEST

1. Turn ignition switch ON.
2. Select "STEP LAMP TEST" of BCM (INT LAMP) active test item.
3. With operating the test items, check that step lamp turns ON/OFF.

On : Step lamp ON

Off : Step lamp OFF

Does the step lamp turn ON/OFF?

- YES >> Step lamp circuit is normal.
NO >> Refer to [INL-37, "Diagnosis Procedure"](#).

Diagnosis Procedure

INFOID:000000009010380

1.CHECK STEP LAMP OUTPUT

CONSULT ACTIVE TEST

1. Turn ignition switch OFF.
2. Remove the step lamp bulbs (ALL).
3. Turn ignition switch ON.
4. Select "STEP LAMP TEST" of BCM (INT LAMP) active test item.
5. With operating the test item, check continuity between BCM harness connector and ground.

BCM		Ground	Test item		Continuity
Connector	Terminal		STEP LAMP TEST	On	Existed
M70	62			Off	Not existed

Is the inspection result normal?

- YES >> GO TO 2.
NO-1 >> Continuity exists and remains unchanged: GO TO 3.
NO-2 >> Continuity does not exist and remains unchanged: Replace BCM. Refer to [BCS-82, "Removal and Installation"](#).

2.CHECK STEP LAMP OPEN CIRCUIT

1. Turn ignition switch OFF.
2. Disconnect BCM connector, and step lamp connector.
3. Check continuity between BCM harness connector and step lamp harness connector.

BCM		Step lamp		Continuity
Connector	Terminal	Connector	Terminal	
M70	62	Driver side	D8	Existed
		Passenger side	D29	
		Rear LH	D66	
		Rear RH	D46	

A
B
C
D
E
F
G
H
I
J
K
M
N
O
P

INL

STEP LAMP CIRCUIT

< DTC/CIRCUIT DIAGNOSIS >

Is the inspection result normal?

YES >> Replace step lamp.

NO >> Repair or replace harnesses.

3. CHECK STEP LAMP SHORT CIRCUIT

1. Turn ignition switch OFF.
2. Check continuity between BCM harness connector and ground.

BCM		Ground	Continuity
Connector	Terminal		
M70	62		Not existed

Is the inspection result normal?

YES >> Repair or replace harnesses.

NO >> Replace BCM. Refer to [BCS-82. "Removal and Installation"](#).

PUDDLE LAMP CIRCUIT

< DTC/CIRCUIT DIAGNOSIS >

PUDDLE LAMP CIRCUIT

Description

INFOID:000000009010381

Controls the puddle lamp (ground side) to turn the puddle lamp ON and OFF.

Diagnosis Procedure

INFOID:000000009010382

NOTE:

Before performing the diagnosis, check that the interior room lamp power supply is normal.

1. CHECK PUDDLE LAMP OUTPUT

1. Turn ignition switch OFF.
2. Disconnect puddle lamp connector.
3. Check continuity between BCM harness connector and ground.

BCM		Ground	Condition		Continuity
Connector	Terminal		Any door (except back door)	Open	Existed
M71	72			Closed	Not existed

Is the inspection result normal?

YES >> GO TO 2.

NO-1 >> Continuity exists and remains unchanged: GO TO 3.

NO-2 >> Continuity does not exist and remains unchanged: Replace BCM. Refer to [BCS-82. "Removal and Installation"](#).

2. CHECK PUDDLE LAMP OPEN CIRCUIT

1. Disconnect BCM connector.
2. Check continuity between BCM harness connector and puddle lamp harness connector.

BCM		Puddle lamp			Continuity
Connector	Terminal	Connector		Terminal	
M71	72	Driver side	D3	14	Existed
		Passenger side	D23		

Is the inspection result normal?

YES >> Replace puddle lamp.

NO >> Repair or replace harnesses.

3. CHECK PUDDLE LAMP SHORT CIRCUIT

1. Disconnect BCM connector.
2. Check continuity between BCM harness connector and ground.

BCM		Ground	Continuity
Connector	Terminal		Not existed
M71	72		

Is the inspection result normal?

YES >> Replace BCM. Refer to [BCS-82. "Removal and Installation"](#).

NO >> Repair or replace harnesses.

A
B
C
D
E
F
G
H
I
J
K
M
N
O
P

INL

PUSH-BUTTON IGNITION SWITCH ILLUMINATION CIRCUIT

< DTC/CIRCUIT DIAGNOSIS >

PUSH-BUTTON IGNITION SWITCH ILLUMINATION CIRCUIT

Component Function Check

INFOID:000000009010383

1. CHECK PUSH-BUTTON IGNITION SWITCH ILLUMINATION OPERATION

CONSULT ACTIVE TEST

1. Turn the ignition switch ON.
2. Select "ENGINE SW ILLUMI" of BCM (INTELLIGENT KEY) active test item.
3. With operating the test items, check that the push-button ignition switch illumination turns ON/OFF.

On : Push-button ignition switch illumination ON

Off : Push-button ignition switch illumination OFF

Does the push-button ignition switch illumination turn ON/OFF?

YES >> Push-button ignition switch illumination circuit is normal.

NO >> Refer to [INL-40, "Diagnosis Procedure"](#).

Diagnosis Procedure

INFOID:000000009010384

1. CHECK PUSH-BUTTON IGNITION SWITCH ILLUMINATION POWER SUPPLY OUTPUT

1. Turn ignition switch OFF.
2. Lighting switch OFF.
3. Disconnect push-button ignition switch connector.
4. Check voltage between push-button ignition switch harness connector and ground.

(+)		(-)	Condition	Voltage (Approx.)	
Connector	Terminal				
M101	3	Ground	Push-button ignition switch illumination	ON Condition	12 V
			OFF Condition	0 V	

Is the inspection result normal?

YES >> GO TO 4.

NO >> GO TO 2.

2. CHECK PUSH-BUTTON IGNITION SWITCH ILLUMINATION POWER SUPPLY OPEN CIRCUIT

1. Turn the ignition switch OFF.
2. Disconnect BCM connector.
3. Check continuity between BCM harness connector and the push-button ignition switch harness connector.

BCM		Push-button ignition switch		Continuity
Connector	Terminal	Connector	Terminal	
M71	90	M101	3	Existed

Is the inspection result normal?

YES >> GO TO 3.

NO >> Repair or replace harnesses.

3. CHECK PUSH-BUTTON IGNITION SWITCH ILLUMINATION POWER SUPPLY SHORT CIRCUIT

Check continuity between BCM harness connector and ground.

BCM		Ground	Continuity
Connector	Terminal		
M71	90		Not existed

Is the inspection result normal?

YES >> Replace BCM. Refer to [BCS-82, "Removal and Installation"](#).

PUSH-BUTTON IGNITION SWITCH ILLUMINATION CIRCUIT

< DTC/CIRCUIT DIAGNOSIS >

NO >> Repair or replace harnesses.

4. CHECK PUSH-BUTTON IGNITION SWITCH ILLUMINATION GROUND CIRCUIT-1

1. Connect push-button ignition switch connector.
2. Check voltage between BCM harness connector and ground.

(+)		(-)	Condition		Voltage (Approx.)
BCM					
Connector	Terminal				
M71	92	Ground	Push-button ignition switch illumination	ON Condition	0 V

Is the inspection result normal?

YES >> GO TO 5.

NO >> Replace BCM. Refer to [BCS-82, "Removal and Installation"](#).

5. CHECK PUSH-BUTTON IGNITION SWITCH ILLUMINATION GROUND CIRCUIT-2

1. Check continuity between push-button ignition switch harness connector and BCM harness connector.

Push-button ignition switch		BCM		Continuity
Connector	Terminal	Connector	Terminal	
M101	2	M71	92	Existed

2. Check continuity between push-button ignition switch harness connector and ground.

Push-button ignition switch		Ground	Continuity
Connector	Terminal		
M101	2		Not existed

Is the inspection result normal?

YES >> Replace push-button ignition switch.

NO >> Repair or replace harnesses.

A
B
C
D
E
F
G
H
I
J
K
L
M
N
O
P

INL

INTERIOR LIGHTING SYSTEM SYMPTOMS

< SYMPTOM DIAGNOSIS >

SYMPTOM DIAGNOSIS

INTERIOR LIGHTING SYSTEM SYMPTOMS

Symptom Table

INFOID:000000009010385

NOTE:

Perform the self-diagnosis with CONSULT before the symptom diagnosis. Perform the trouble diagnosis if any DTC is detected.

Symptom	Possible cause	Inspection item
<p>All the following lamps do not turn ON.</p> <ul style="list-style-type: none"> • Map lamp • Personal lamp • Vanity mirror lamp • Foot lamp • Step lamp • Puddle lamp • Luggage room lamp • Automatic back door close switch illumination 	<ul style="list-style-type: none"> • Harness between BCM and each interior room lamp • BCM 	<p>Interior room lamp power supply circuit Refer to INL-30, "Component Function Check".</p>
<ul style="list-style-type: none"> • Interior room lamp does not turn ON even though the door is open. (It turns ON when turning the interior room lamp ON.) • Interior room lamp does not turn OFF even though the door is closed. 	<ul style="list-style-type: none"> • Harness between BCM and each door switch • Harness between BCM and each interior room lamp • BCM 	<p>Door switch circuit Refer to DLK-98, "Component Function Check".</p> <p>Interior room lamp control circuit Refer to INL-33, "Component Function Check".</p>
<p>Interior room lamp timer does not activate. (It turns ON/ OFF when the door opens/closes.)</p>	—	<p>Check the interior room lamp setting. Refer to INL-14.</p>
<ul style="list-style-type: none"> • Puddle lamp does not turn ON even though the door is open. • Puddle lamp does not turn OFF even though the door is closed. 	<ul style="list-style-type: none"> • Harness between BCM and each door switch • Harness between BCM and puddle lamp • BCM 	<p>Door switch circuit Refer to DLK-98, "Component Function Check".</p> <p>Puddle lamp circuit Refer to INL-39, "Diagnosis Procedure".</p>
<ul style="list-style-type: none"> • Luggage room lamp or automatic back door close switch illumination does not turn ON even though the back door is open. (It turns ON when turning the luggage room lamp ON.) • Luggage room lamp or automatic back door close switch illumination does not turn OFF even though the back door is closed. 	<ul style="list-style-type: none"> • Harness between BCM and back door switch • Harness between BCM and luggage room lamp • Harness between BCM and automatic back door close switch • BCM 	<p>Back door switch circuit Refer to DLK-101, "Component Function Check".</p> <p>Luggage room lamp circuit Refer to INL-35, "Diagnosis Procedure".</p>
<ul style="list-style-type: none"> • Step lamps (ALL) do not turn ON. • Step lamps (ALL) do not turn OFF. 	<ul style="list-style-type: none"> • Harness between BCM and each step lamp • BCM 	<p>Door switch circuit Refer to DLK-98, "Component Function Check".</p> <p>Step lamp circuit Refer to INL-37.</p>
<p>Push-button ignition switch illumination does not illuminate.</p>	<ul style="list-style-type: none"> • Harness between BCM and push-button ignition switch • BCM 	<p>Push-button ignition switch illumination circuit Refer to INL-40, "Component Function Check".</p>
<p>Interior room lamp battery saver does not activate.</p>	<p>BCM</p>	<p>Replace BCM. Refer to BCS-82, "Removal and Installation".</p>

MAP LAMP

< REMOVAL AND INSTALLATION >

REMOVAL AND INSTALLATION

MAP LAMP

Exploded View

INFOID:000000009010386

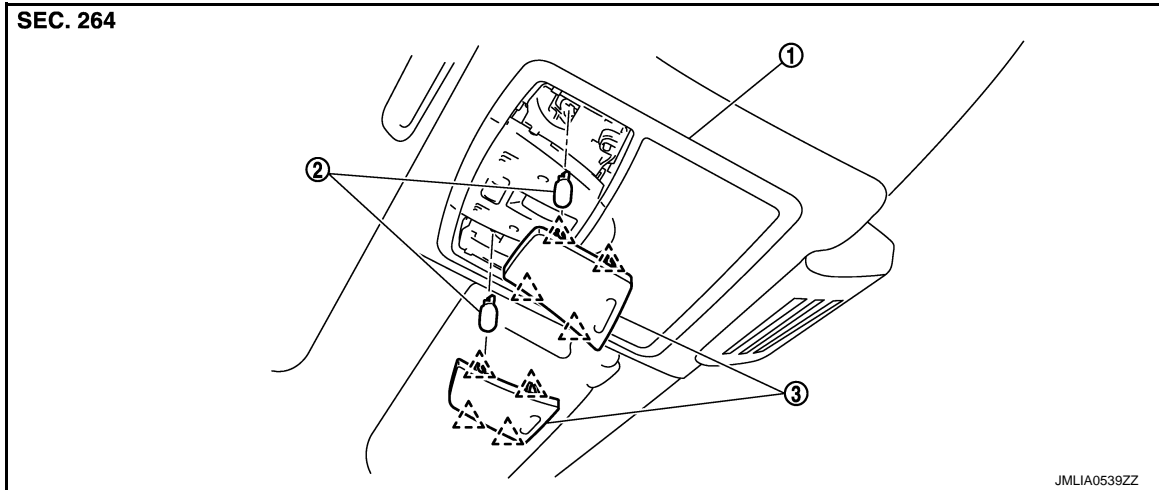

1. Map lamp assembly

2. Bulb

3. Lens

 : Pawl

Removal and Installation

INFOID:000000009010387

Refer to [INT-28. "Removal and Installation"](#) for the map lamp assembly removal and installation.

Replacement

INFOID:000000009010388

CAUTION:

- Disconnect the battery cable from negative terminal or remove the fuse.
- Never touch the glass of bulb directly by hand. Keep grease and other oily substances away from it. Never touch bulb by hand while it is lit or right after it is off.
- Never leave bulb out of lamp reflector for a long time because dust, moisture smoke, etc. may affect the performance of lamp. When replacing bulb, be sure to replace it with a new one.

MAP LAMP BULB

1. Insert any appropriate tool into the gap between the lens, and then remove the lens.
2. Remove the bulb.

A
B
C
D
E
F
G
H
I
J
K
L
M
N
O
P

INL

VANITY MIRROR LAMP

< REMOVAL AND INSTALLATION >

VANITY MIRROR LAMP

Exploded View

INFOID:000000009010389

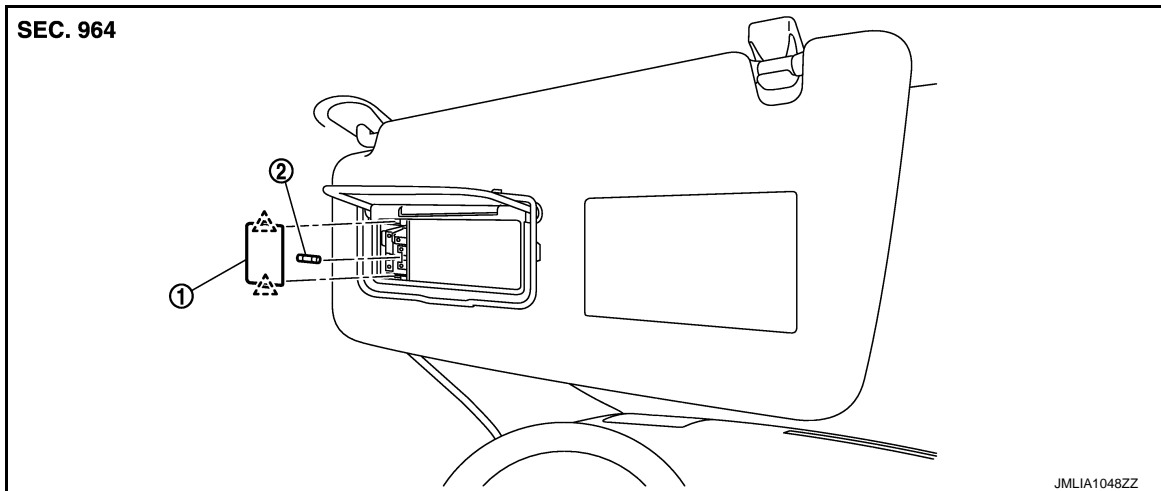

1. Lens

2. Bulb

 : Pawl

Replacement

INFOID:000000009010390

CAUTION:

- Disconnect the battery cable from negative terminal or remove the fuse.
- Never touch the glass of bulb directly by hand. Keep grease and other oily substances away from it. Never touch bulb by hand while it is lit or right after it is off.
- Never leave bulb out of lamp reflector for a long time because dust, moisture smoke, etc. may affect the performance of lamp. When replacing bulb, be sure to replace it with a new one.

VANITY MIRROR LAMP BULB

1. Insert any appropriate tool into the gap between the lens, and then remove the lens.
2. Remove the bulb.

GLOVE BOX LAMP

< REMOVAL AND INSTALLATION >

GLOVE BOX LAMP

Exploded View

INFOID:000000009010391

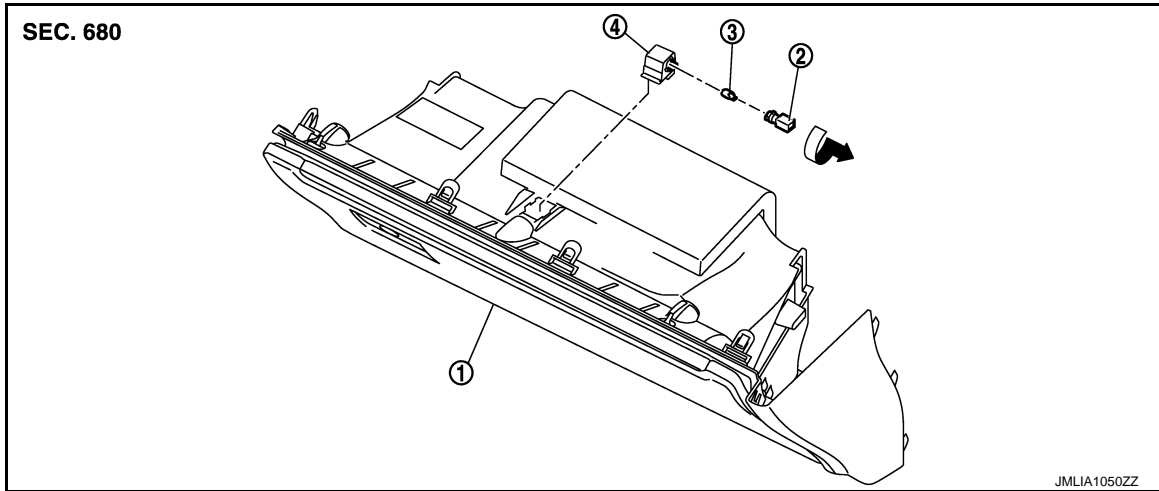

1. Glove box assembly
2. Bulb socket
3. Bulb
4. Lamp housing

Replacement

INFOID:000000009010392

CAUTION:

- Disconnect the battery cable from negative terminal or remove the fuse.
- Never touch the glass of bulb directly by hand. Keep grease and other oily substances away from it. Never touch bulb by hand while it is lit or right after it is off.
- Never leave bulb out of lamp reflector for a long time because dust, moisture smoke, etc. may affect the performance of lamp. When replacing bulb, be sure to replace it with a new one.

GLOVE BOX LAMP BULB

1. Remove glove box assembly. Refer to [IP-13, "Removal and Installation"](#).
2. Rotate the bulb socket counterclockwise and unlock it.
3. Remove the bulb.

A
B
C
D
E
F
G
H
I
J
K
INL
M
N
O
P

FOOT LAMP

< REMOVAL AND INSTALLATION >

FOOT LAMP DRIVER SIDE

DRIVER SIDE : Exploded View

INFOID:000000009010393

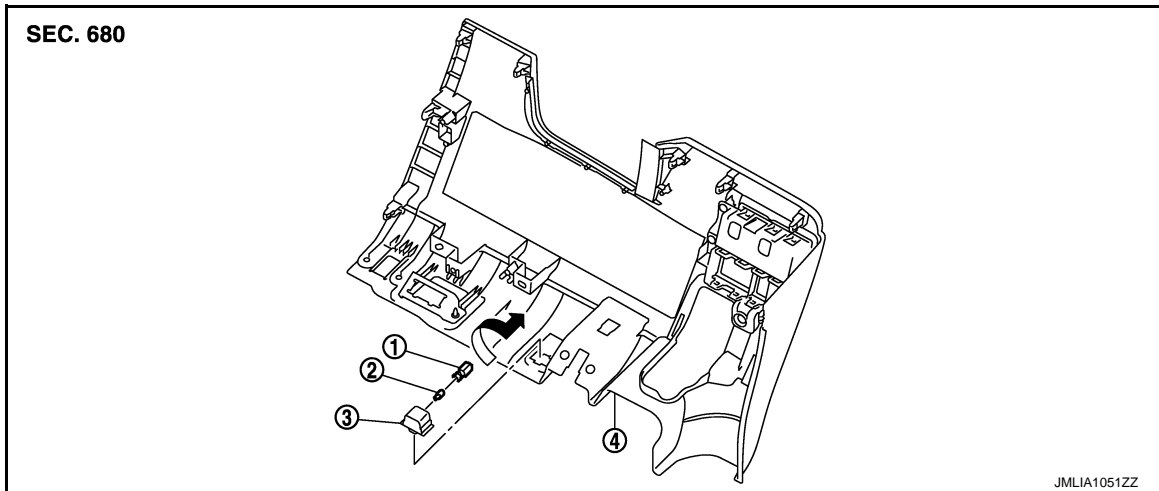

1. Bulb socket
2. Bulb
3. Lamp housing
4. Instrument lower panel LH

DRIVER SIDE : Replacement

INFOID:000000009010394

CAUTION:

- Disconnect the battery cable from negative terminal or remove the fuse.
- Never touch the glass of bulb directly by hand. Keep grease and other oily substances away from it. Never touch bulb by hand while it is lit or right after it is off.
- Never leave bulb out of lamp reflector for a long time because dust, moisture smoke, etc. may affect the performance of lamp. When replacing bulb, be sure to replace it with a new one.

FOOT LAMP BULB (DRIVER SIDE)

1. Remove instrument lower panel LH. Refer to [IP-13, "Removal and Installation"](#).
2. Rotate the bulb socket counterclockwise and unlock it.
3. Remove the bulb.

PASSENGER SIDE

PASSENGER SIDE : Exploded View

INFOID:000000009010395

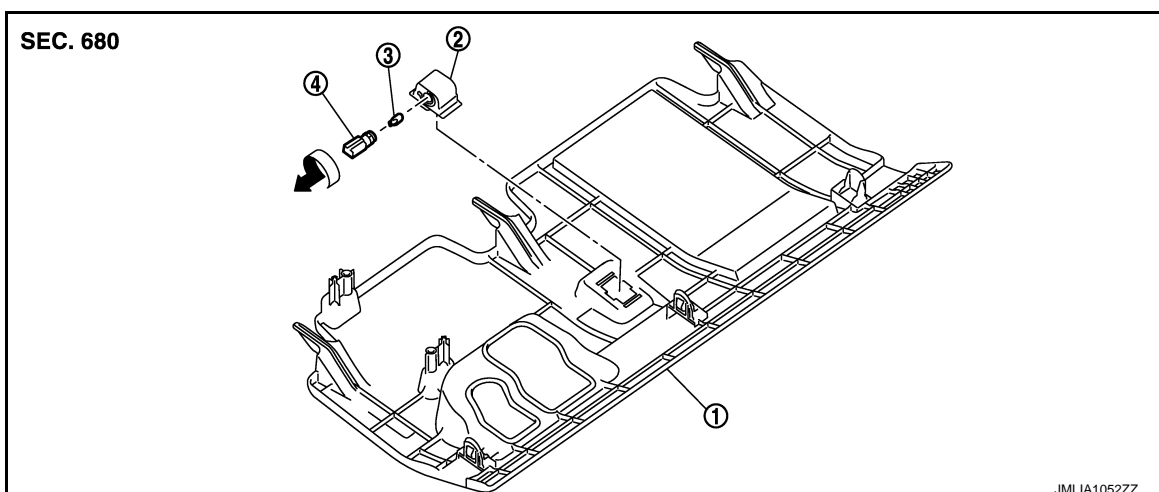

FOOT LAMP

< REMOVAL AND INSTALLATION >

1. Instrument lower cover
2. Lamp housing
3. Bulb
4. Bulb socket

PASSENGER SIDE : Replacement

INFOID:000000009010396

CAUTION:

- Disconnect the battery cable from negative terminal or remove the fuse.
- Never touch the glass of bulb directly by hand. Keep grease and other oily substaces away from it. Never touch bulb by hand while it is lit or right after it is off.
- Never leave bulb out of lamp reflector for a long time because dust, moisture smoke, etc. may affect the performance of lamp. When replacing bulb, be sure to replace it with a new one.

FOOT LAMP BULB (PASSENGER SIDE)

1. Remove instrument lower cover. Refer to [IP-13, "Removal and Installation"](#).
2. Rotate the bulb socket counterclockwise and unlock it.
3. Remove the bulb.

REAR FOOT LAMP

REAR FOOT LAMP : Exploded View

INFOID:000000009010397

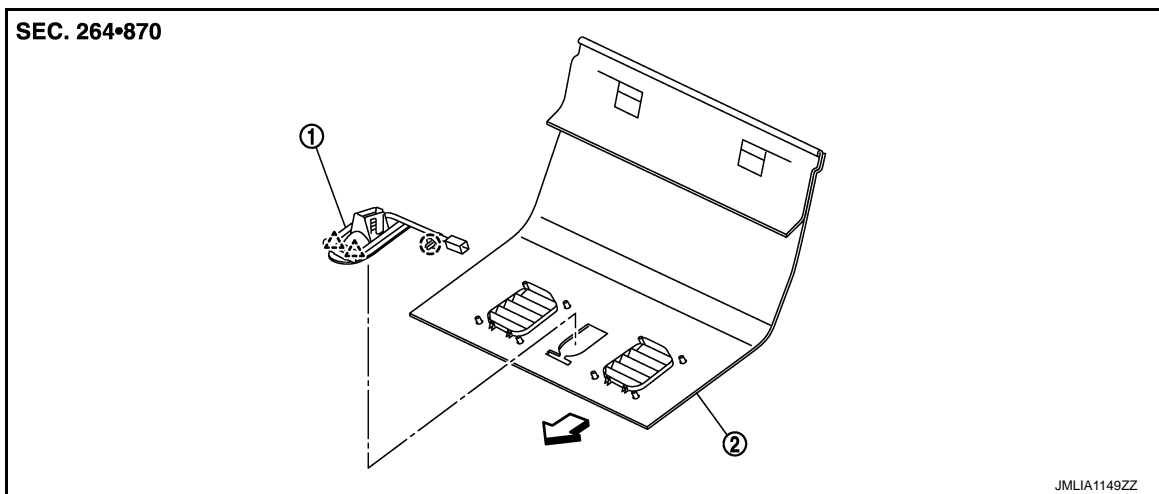

1. Rear foot lamp assembly
2. Seatback lower carpet

○ : Clip

△ : Pawl

← Vehicle front

REAR FOOT LAMP : Removal and Installation

INFOID:000000009010398

CAUTION:

- Disconnect the battery cable from negative terminal or remove the fuse.
- Never touch rear foot lamp assembly directly by hand. Keep grease and other oily substaces away from it.
- Never touch rear foot lamp assembly by hand while it is lit or right after it is off.

REMOVAL

1. Remove seat cushion front finisher. Refer to [SE-81, "Removal and Installation"](#).
2. Release seatback lower carpet band from the back of seat cushion frame.
3. Pull seatback lower carpet toward vehicle rear from underside.

FOOT LAMP

< REMOVAL AND INSTALLATION >

4. Disengage rear foot lamp assembly fixing pawls using a small flat-bladed screwdriver (A) as shown by the arrow in the figure.

- △ :Pawl
← :Vehicle front

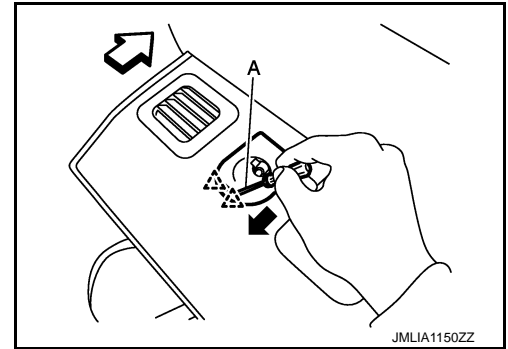

5. Remove rear foot lamp assembly from seatback lower carpet.

INSTALLATION

Note the following items, and install in the reverse order of removal.

CAUTION:

- Rear foot lamp cannot be disassembled.
- Always replace rear foot lamp as an assembly, when replacing.

STEP LAMP

< REMOVAL AND INSTALLATION >

STEP LAMP

Exploded View

INFOID:000000009010399

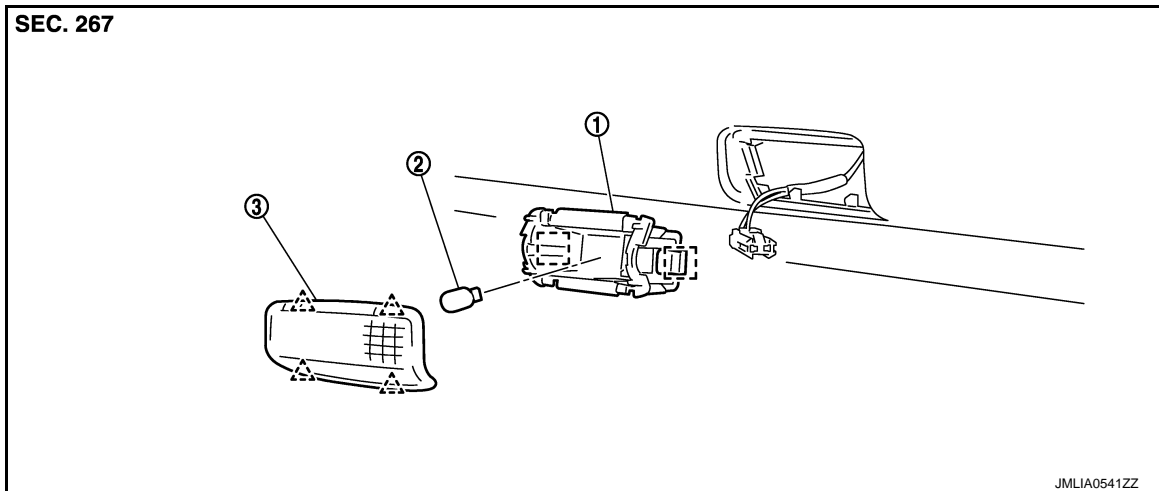

1. Step lamp housing

2. Bulb

3. Lens

 : Pawl

 : Metal clip

Removal and Installation

INFOID:000000009010400

CAUTION:

- Disconnect the battery cable from negative terminal or remove the fuse.
- Never touch the glass of bulb directly by hand. Keep grease and other oily substances away from it. Never touch bulb by hand while it is lit or right after it is off.
- Never leave bulb out of lamp reflector for a long time because dust, moisture smoke, etc. may affect the performance of lamp. When replacing bulb, be sure to replace it with a new one.

REMOVAL

1. Insert any appropriate tool into the gap between the step lamp and door finisher.
2. Disconnect the step lamp harness connector, and then remove the step lamp.

INSTALLATION

Install in the reverse order of removal.

Replacement

INFOID:000000009010401

STEP LAMP BULB

1. Remove the step lamp.
2. Remove the lens.
3. Remove the bulb.

MOOD LAMP

< REMOVAL AND INSTALLATION >

MOOD LAMP

FRONT DOOR ARMREST

FRONT DOOR ARMREST : Exploded View

INFOID:000000009010402

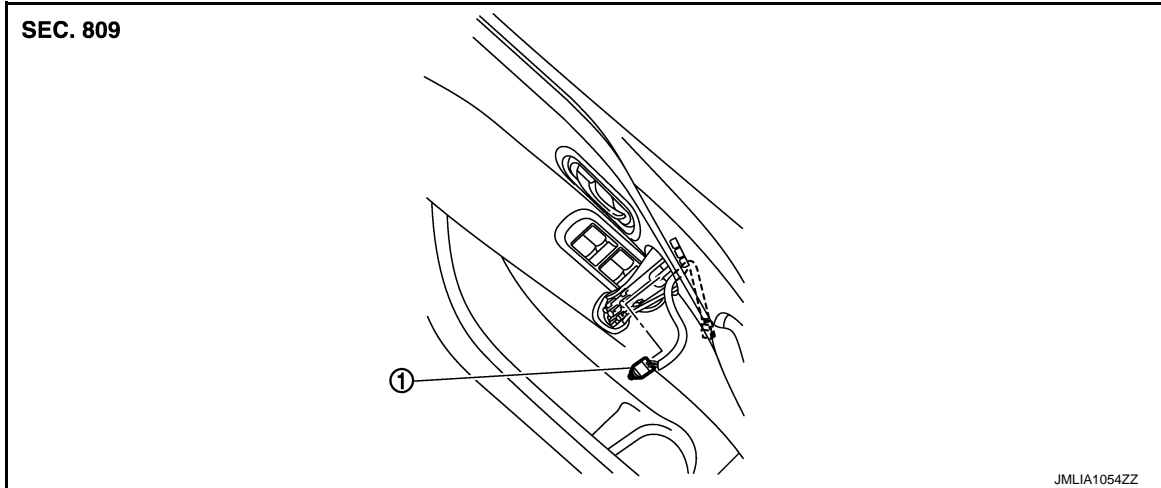

1. Mood lamp

FRONT DOOR ARMREST : Replacement

INFOID:000000009010403

CAUTION:

- Disconnect the battery cable from negative terminal or remove the fuse.
- Never touch the glass of bulb directly by hand. Keep grease and other oily substances away from it. Never touch bulb by hand while it is lit or right after it is off.
- Never leave bulb out of lamp reflector for a long time because dust, moisture smoke, etc. may affect the performance of lamp. When replacing bulb, be sure to replace it with a new one.

MOOD LAMP

1. Remove front door finisher. Refer to [INT-13, "Removal and Installation"](#).
2. Remove the mood lamp from front door finisher.

REAR DOOR ARMREST

REAR DOOR ARMREST : Exploded View

INFOID:000000009010404

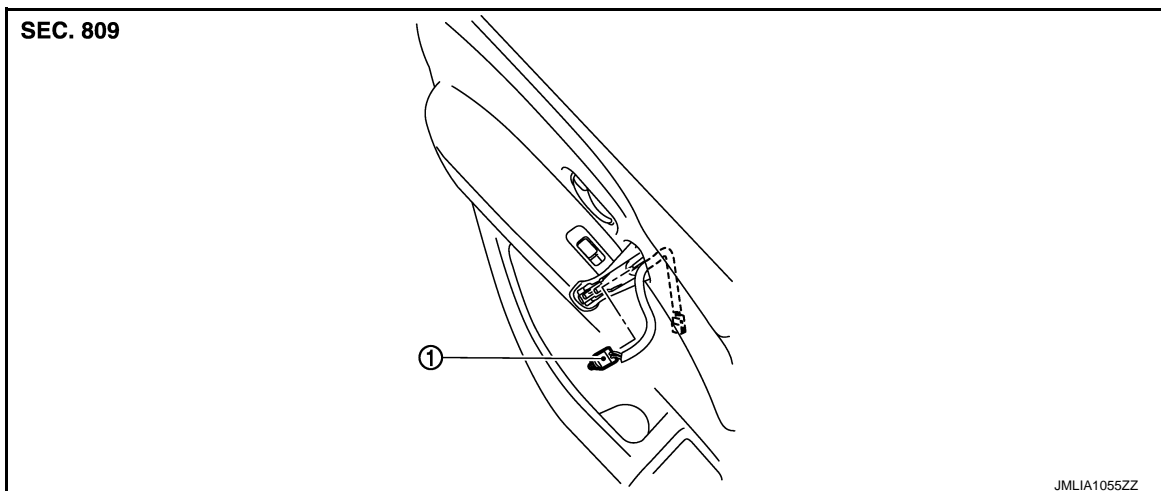

1. Mood lamp

MOOD LAMP

< REMOVAL AND INSTALLATION >

REAR DOOR ARMREST : Replacement

INFOID:000000009010405

CAUTION:

- Disconnect the battery cable from negative terminal or remove the fuse.
- Never touch the glass of bulb directly by hand. Keep grease and other oily substances away from it. Never touch bulb by hand while it is lit or right after it is off.
- Never leave bulb out of lamp reflector for a long time because dust, moisture smoke, etc. may affect the performance of lamp. When replacing bulb, be sure to replace it with a new one.

MOOD LAMP

1. Remove rear door finisher. Refer to [INT-13. "Removal and Installation"](#).
2. Remove the mood lamp from rear door finisher.

A
B
C
D
E
F
G
H
I
J
K
INL
M
N
O
P

PERSONAL LAMP

< REMOVAL AND INSTALLATION >

PERSONAL LAMP

Exploded View

INFOID:000000009010406

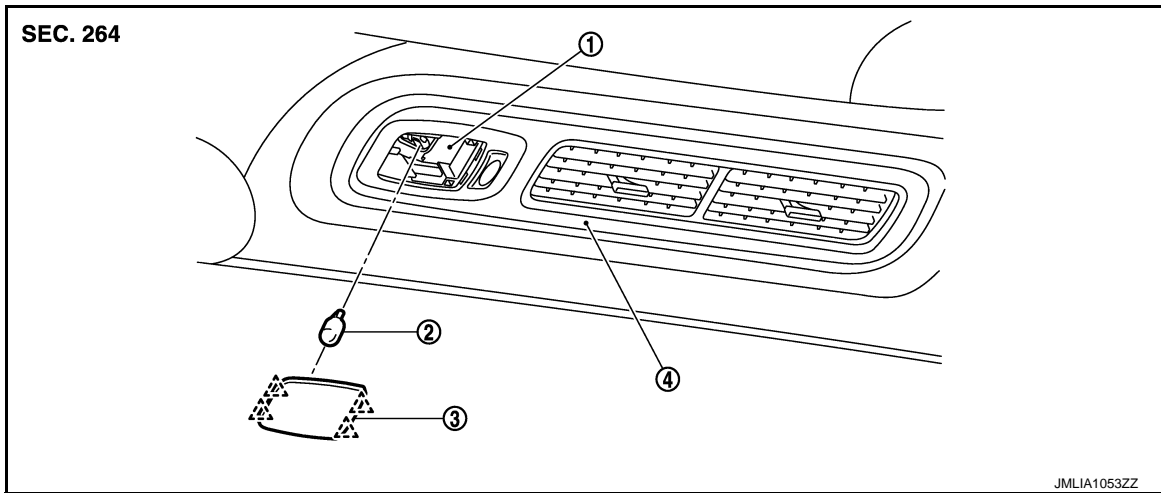

1. Personal lamp case 2. Bulb 3. Lens
4. Personal lamp finisher

 : Pawl

Removal and Installation

INFOID:000000009010407

CAUTION:

- Disconnect the battery cable from negative terminal or remove the fuse.
- Never touch the glass of bulb directly by hand. Keep grease and other oily substances away from it. Never touch bulb by hand while it is lit or right after it is off.
- Never leave bulb out of lamp reflector for a long time because dust, moisture smoke, etc. may affect the performance of lamp. When replacing bulb, be sure to replace it with a new one.
- Replace the personal lamp case as a set (LH and RH). After removing the headlining assembly, remove the personal lamp case.

REMOVAL

1. Remove headlining assembly. Refer to [INT-28, "Removal and Installation"](#).

PERSONAL LAMP

< REMOVAL AND INSTALLATION >

2. Press the pawls (B) on both sides as shown in the figure using a small flat-bladed screwdriver (A), and then pull out personal lamp case (2) from personal lamp finisher (1).

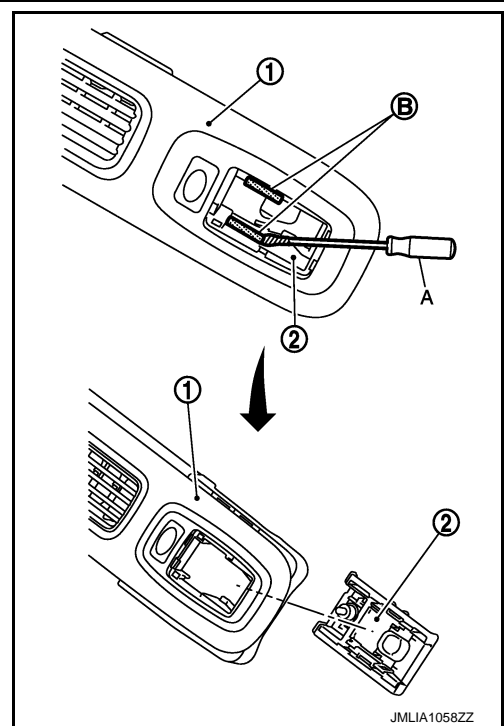

INSTALLATION

Install in the reverse order of removal.

Replacement

INFOID:000000009010408

CAUTION:

- Disconnect the battery negative terminal or remove the fuse.
- Never touch the glass of bulb directly by hand. Keep grease and other oily matters away from it. Never touch bulb by hand while it is lit or right after being turned off.
- Never leave bulb out of lamp reflector for a long time because dust, moisture smoke, etc. may affect the performance of lamp. When replacing bulb, be sure to replace it with new one.

PERSONAL LAMP BULB

1. Insert any appropriate tool into the gap between the lens, and then remove the lens.
2. Remove the bulb.

A
B
C
D
E
F
G
H
I
J
K

INL

M
N
O
P

PUDDLE LAMP

< REMOVAL AND INSTALLATION >

PUDDLE LAMP

Exploded View

INFOID:000000009010409

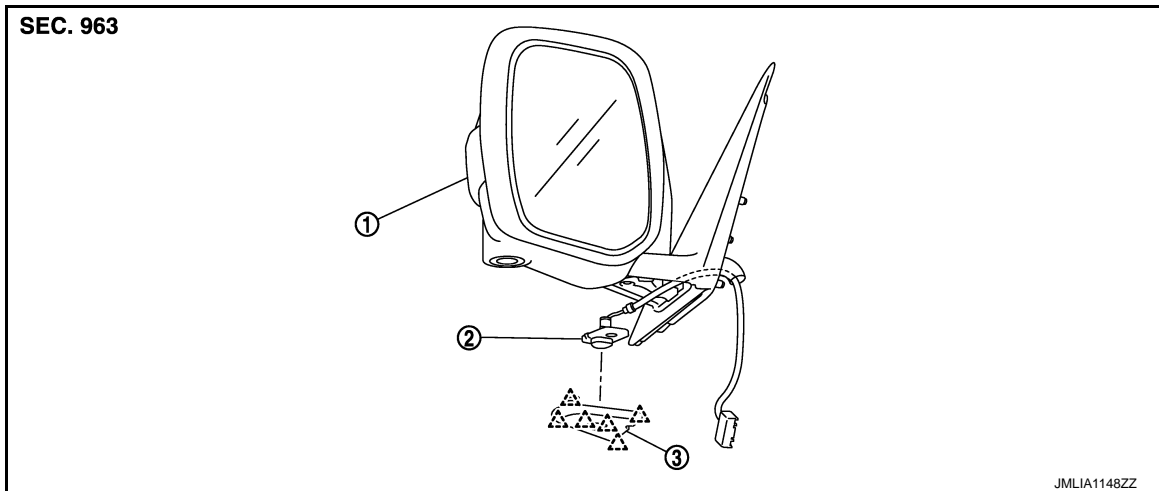

1. Door mirror assembly

2. Puddle lamp

3. Base cover

 : Pawl

Removal and Installation

INFOID:000000009010410

CAUTION:

- Disconnect the battery cable from negative terminal or remove the fuse.
- Never touch puddle lamp directly by hand. Keep grease and other oily substances away from it.
- Never touch puddle lamp by hand while it is lit or right after it is off.
- It is prohibited to disassemble puddle lamp.
- Always replace puddle lamp as an assembly, when replacing.

REMOVAL

1. Remove door mirror assembly. Refer to [MIR-23, "DOOR MIRROR ASSEMBLY : Removal and Installation"](#).
2. Disconnect puddle lamp harness connector terminal from door mirror harness connector.
3. Disengage base cover fixing pawls using a small flat-bladed screwdriver (A), and then remove base cover.

CAUTION:

- Apply protective tape (B) around the base to protect the surface from damage.
- Apply protective tape to small flat-bladed screwdriver.

 : Pawl

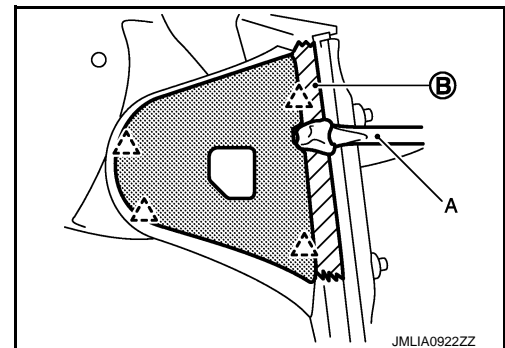

PUDDLE LAMP

< REMOVAL AND INSTALLATION >

4. Disengage puddle lamp fixing pawls, and then remove puddle lamp (1) from base cover (2).

 : Pawl

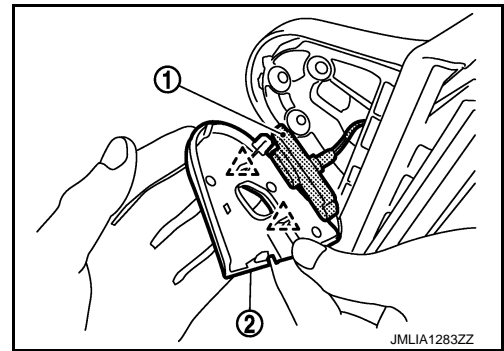

INSTALLATION

Install in the reverse order of removal.

A
B
C
D
E
F
G
H
I
J
K
L
M
N
O
P

INL

LUGGAGE ROOM LAMP

< REMOVAL AND INSTALLATION >

LUGGAGE ROOM LAMP

Exploded View

INFOID:000000009010411

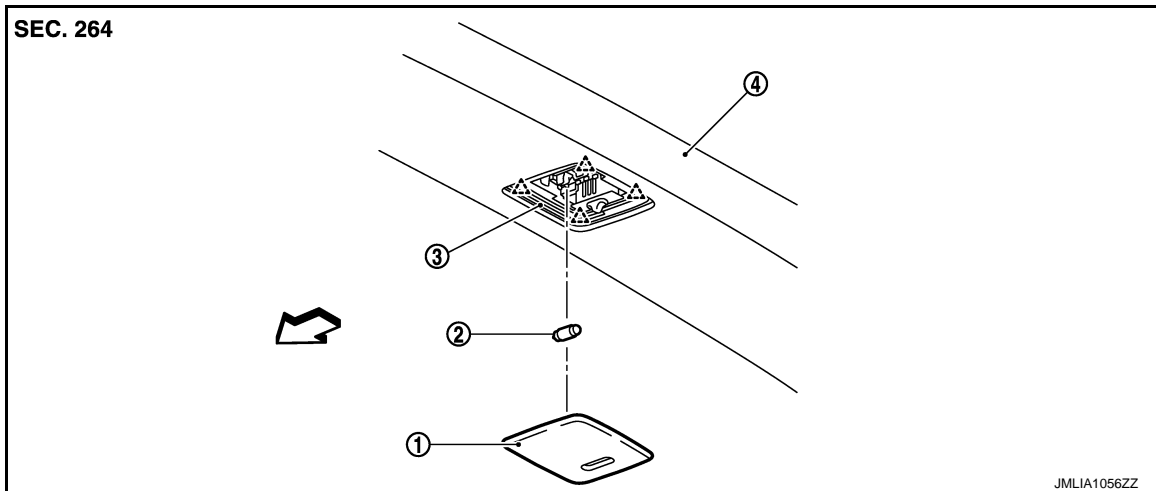

1. Lens 2. Bulb 3. Luggage room lamp housing

4. Roof garnish

 : Pawl

 : Vehicle front

Removal and Installation

INFOID:000000009010412

CAUTION:

- **Disconnect the battery cable from negative terminal or remove the fuse.**
- **Never touch the glass of bulb directly by hand. Keep grease and other oily substances away from it. Never touch bulb by hand while it is lit or right after it is off.**
- **Never leave bulb out of lamp reflector for a long time because dust, moisture smoke, etc. may affect the performance of lamp. When replacing bulb, be sure to replace it with a new one.**

REMOVAL

1. Insert any appropriate tool into the gap between lens and roof garnish, and then remove lens.
2. Disengage luggage room lamp housing fixing metal clips, and then disconnect luggage room lamp harness connector.
3. Remove luggage room lamp housing.

INSTALLATION

Install in the reverse order of removal.

Replacement

INFOID:000000009010413

CAUTION:

- **Disconnect the battery cable from negative terminal or remove the fuse.**
- **Never touch the glass of bulb directly by hand. Keep grease and other oily substances away from it. Never touch bulb by hand while it is lit or right after it is off.**
- **Never leave bulb out of lamp reflector for a long time because dust, moisture smoke, etc. may affect the performance of lamp. When replacing bulb, be sure to replace it with a new one.**

LUGGAGE ROOM LAMP BULB

1. Insert any appropriate tool into the gap between lens and roof garnish, and then remove the lens.
2. Remove bulb.

SERVICE DATA AND SPECIFICATIONS (SDS)

< SERVICE DATA AND SPECIFICATIONS (SDS)

SERVICE DATA AND SPECIFICATIONS (SDS)

SERVICE DATA AND SPECIFICATIONS (SDS)

Bulb Specifications

INFOID:000000009010414

Item	Type	Wattage (W)
Push-button ignition switch illumination	LED	—
Map lamp	Wedge	8
Console lamp (integrated into the map lamp assembly)	LED	—
Puddle lamp	LED	—
Vanity mirror lamp	—	2
Glove box lamp	Wedge	1.4
Foot lamp (driver and passenger)	Wedge	1.4
Rear foot lamp	LED	—
Mood lamp (front and rear door armrest)	LED	—
Step lamp	Wedge	8
Personal lamp	Wedge	8
Luggage room lamp	—	8

A
B
C
D
E
F
G
H
I
J
K
INL
M
N
O
P