

MWI

SECTION

METER, WARNING LAMP & INDICATOR

A
B
C
D
E
F
G
H
I
J
K
L
M
MWI
O
P

CONTENTS

PRECAUTION	FUEL GAUGE	
PRECAUTIONS	FUEL GAUGE : System Diagram	
Precaution for Supplemental Restraint System (SRS) "AIR BAG" and "SEAT BELT PRE-TENSIONER"	FUEL GAUGE : System Description	
PREPARATION	ENGINE OIL PRESSURE GAUGE	
PREPARATION	ENGINE OIL PRESSURE GAUGE : System Diagram	
Commercial Service Tools	ENGINE OIL PRESSURE GAUGE : System Description	
SYSTEM DESCRIPTION	VOLTMETER	
COMPONENT PARTS	VOLTMETER : System Diagram	
METER SYSTEM	VOLTMETER : System Description	
METER SYSTEM : Component Parts Location	OIL PRESSURE WARNING LAMP	
METER SYSTEM : Component Description	OIL PRESSURE WARNING LAMP : System Diagram	
CLOCK	OIL PRESSURE WARNING LAMP : System Description	
CLOCK : Component Parts Location	MASTER WARNING LAMP	
SYSTEM	MASTER WARNING LAMP : System Diagram	
METER SYSTEM	MASTER WARNING LAMP : System Description	
METER SYSTEM : System Diagram	METER ILLUMINATION CONTROL	
METER SYSTEM : System Description	METER ILLUMINATION CONTROL : System Diagram	
METER SYSTEM : Fail-Safe	METER ILLUMINATION CONTROL : System Description	
SPEEDOMETER	METER EFFECT FUNCTION	
SPEEDOMETER : System Diagram	METER EFFECT FUNCTION : System Diagram	
SPEEDOMETER : System Description	METER EFFECT FUNCTION : System Description	
TACHOMETER	INFORMATION DISPLAY	
TACHOMETER : System Diagram	INFORMATION DISPLAY : System Diagram	
TACHOMETER : System Description	INFORMATION DISPLAY : System Description	
ENGINE COOLANT TEMPERATURE GAUGE	OPERATION	
ENGINE COOLANT TEMPERATURE GAUGE : System Diagram	Switch Name and Function	
ENGINE COOLANT TEMPERATURE GAUGE : System Description		

DIAGNOSIS SYSTEM (COMBINATION METER)	30	TRIP RESET AND ILLUMINATION CONTROL SWITCH SIGNAL CIRCUIT	58
On Board Diagnosis Function	30	Diagnosis Procedure	58
CONSULT Function	31	Component Inspection	59
ECU DIAGNOSIS INFORMATION	36	TRIP COMPUTER SWITCH SIGNAL CIRCUIT	60
COMBINATION METER	36	Diagnosis Procedure	60
Reference Value	36	Component Inspection	61
Fail-Safe	43	FUEL LEVEL SENSOR SIGNAL CIRCUIT	62
DTC Index	44	Component Function Check	62
IPDM E/R	45	Diagnosis Procedure	62
List of ECU Reference	45	Component Inspection	63
WIRING DIAGRAM	46	OIL PRESSURE SWITCH SIGNAL CIRCUIT	64
METER SYSTEM	46	Component Function Check	64
Wiring Diagram	46	Diagnosis Procedure	64
CLOCK	49	Component Inspection	64
Wiring Diagram	49	WASHER LEVEL SWITCH SIGNAL CIRCUIT	66
BASIC INSPECTION	50	Diagnosis Procedure	66
DIAGNOSIS AND REPAIR WORKFLOW (METER SYSTEM)	50	Component Inspection	66
Work flow	50	A/C AUTO AMP. CONNECTION RECOGNITION SIGNAL CIRCUIT	67
DTC/CIRCUIT DIAGNOSIS	52	Diagnosis Procedure	67
U1000 CAN COMM CIRCUIT	52	SYMPTOM DIAGNOSIS	68
Description	52	THE FUEL GAUGE INDICATOR DOES NOT OPERATE	68
DTC Logic	52	Description	68
Diagnosis Procedure	52	Diagnosis Procedure	68
U1010 CONTROL UNIT (CAN)	53	THE TRIP RESET AND ILLUMINATION CONTROL SWITCH IS INOPERATIVE	69
Description	53	Description	69
DTC Logic	53	Diagnosis Procedure	69
Diagnosis Procedure	53	THE TRIP COMPUTER SWITCH IS INOPERATIVE	70
B2205 VEHICLE SPEED	54	Description	70
Description	54	Diagnosis Procedure	70
DTC Logic	54	THE OIL PRESSURE WARNING LAMP DOES NOT TURN ON	71
Diagnosis Procedure	54	Description	71
B2267 ENGINE SPEED	55	Diagnosis Procedure	71
Description	55	THE OIL PRESSURE WARNING LAMP DOES NOT TURN OFF	72
DTC Logic	55	Description	72
Diagnosis Procedure	55	Diagnosis Procedure	72
B2268 WATER TEMP	56	THE PARKING BRAKE RELEASE WARNING CONTINUES DISPLAYING, OR DOES NOT DISPLAY	73
Description	56	Description	73
DTC Logic	56	Diagnosis Procedure	73
Diagnosis Procedure	56		
POWER SUPPLY AND GROUND CIRCUIT	57		
COMBINATION METER	57		
COMBINATION METER : Diagnosis Procedure ...	57		

THE LOW WASHER FLUID WARNING CONTINUES DISPLAYING, or DOES NOT DISPLAY74	REMOVAL AND INSTALLATION78	
Description74	COMBINATION METER78	A
Diagnosis Procedure74	Exploded View78	
THE DOOR OPEN WARNING CONTINUES DISPLAYING, OR DOES NOT DISPLAY75	Removal and Installation78	B
Description75	Disassembly and Assembly78	
Diagnosis Procedure75	TRIP RESET AND ILLUMINATION CONTROL SWITCH79	C
THE AMBIENT TEMPERATURE DISPLAY IS INCORRECT76	Exploded View79	
Description76	Removal and Installation79	D
Diagnosis Procedure76	TRIP COMPUTER SWITCH80	
NORMAL OPERATING CONDITION77	Exploded View80	E
INFORMATION DISPLAY77	Removal and Installation80	
INFORMATION DISPLAY : Description77	CLOCK81	F
	Exploded View81	
	Removal and Installation81	G
		H
		I
		J
		K
		L
		M
		O
		P

MWI

PRECAUTIONS

< PRECAUTION >

PRECAUTION

PRECAUTIONS

Precaution for Supplemental Restraint System (SRS) "AIR BAG" and "SEAT BELT PRE-TENSIONER"

INFOID:000000009011893

The Supplemental Restraint System such as "AIR BAG" and "SEAT BELT PRE-TENSIONER", used along with a front seat belt, helps to reduce the risk or severity of injury to the driver and front passenger for certain types of collision. Information necessary to service the system safely is included in the "SRS AIR BAG" and "SEAT BELT" of this Service Manual.

WARNING:

Always observe the following items for preventing accidental activation.

- To avoid rendering the SRS inoperative, which could increase the risk of personal injury or death in the event of a collision that would result in air bag inflation, all maintenance must be performed by an authorized NISSAN/INFINITI dealer.
- Improper maintenance, including incorrect removal and installation of the SRS, can lead to personal injury caused by unintentional activation of the system. For removal of Spiral Cable and Air Bag Module, see "SRS AIR BAG".
- Never use electrical test equipment on any circuit related to the SRS unless instructed to in this Service Manual. SRS wiring harnesses can be identified by yellow and/or orange harnesses or harness connectors.

PRECAUTIONS WHEN USING POWER TOOLS (AIR OR ELECTRIC) AND HAMMERS

WARNING:

Always observe the following items for preventing accidental activation.

- When working near the Air Bag Diagnosis Sensor Unit or other Air Bag System sensors with the ignition ON or engine running, never use air or electric power tools or strike near the sensor(s) with a hammer. Heavy vibration could activate the sensor(s) and deploy the air bag(s), possibly causing serious injury.
- When using air or electric power tools or hammers, always switch the ignition OFF, disconnect the battery, and wait at least 3 minutes before performing any service.

PREPARATION

< PREPARATION >

PREPARATION

PREPARATION

Commercial Service Tools

INFOID:000000009011894

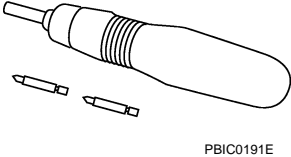
Tool name	Description
<p>Power tool</p>  <p>PBIC0191E</p>	<p>Loosening screws</p>

A

B

C

D

E

F

G

H

I

J

K

L

M

MWI

O

P

COMPONENT PARTS

< SYSTEM DESCRIPTION >

SYSTEM DESCRIPTION

COMPONENT PARTS

METER SYSTEM

METER SYSTEM : Component Parts Location

INFOID:000000009011895

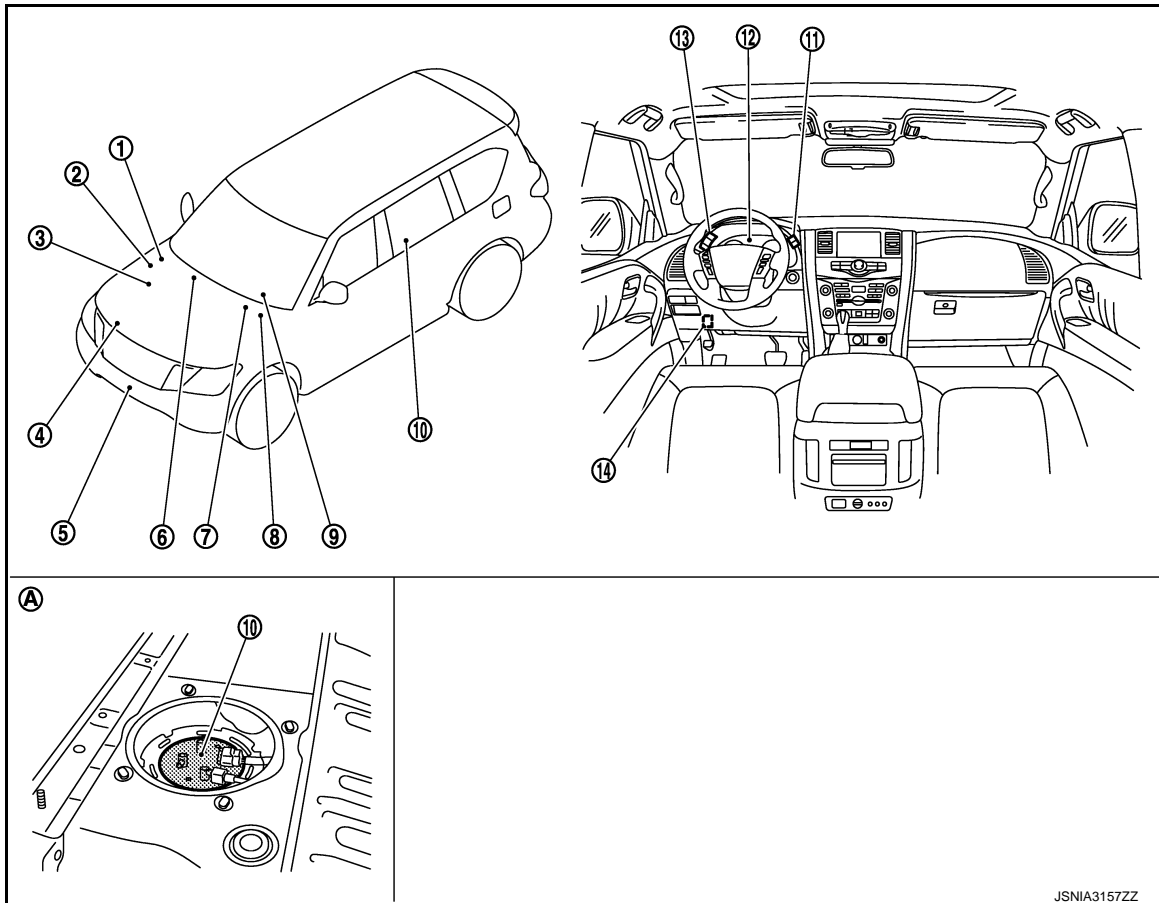

- | | | |
|---|---|--|
| 1. IPDM E/R
Refer to PCS-4, "Component Parts Location" . | 2. ECM
Refer to EC-23, "Component Parts Location" (VK56VD FOR USA AND CANADA).
Refer to EC-576, "Component Parts Location" (VK56VD FOR MEXICO). | 3. Washer level switch |
| 4. Oil pressure switch
Refer to EM-59, "Exploded View" . | 5. Ambient sensor | 6. A/C auto amp.
Refer to HAC-6, "FRONT AUTOMATIC AIR CONDITIONING SYSTEM : Component Parts Location" . |
| 7. TCM
Refer to TM-10, "A/T CONTROL SYSTEM : Component Parts Location" . | 8. ABS actuator and electric unit (control unit)
Refer to BRC-9, "Component Parts Location" . | 9. BCM
Refer to BCS-4, "BODY CONTROL SYSTEM : Component Parts Location" . |
| 10. Fuel level sensor unit | 11. Trip computer switch | 12. Combination meter |
| 13. Trip reset and illumination control switch | 14. Parking brake switch | |
| A. Under of left side second seat | | |

COMPONENT PARTS

< SYSTEM DESCRIPTION >

METER SYSTEM : Component Description

INFOID:000000009011896

Unit	Description
Combination meter	Controls the following with the signals received from each unit via CAN communication and the signals from switches and sensors. <ul style="list-style-type: none"> • Speedometer • Tachometer • Engine coolant temperature gauge • Fuel gauge • Engine oil pressure gauge • Voltmeter • Warning lamps • Indicator lamps • Meter illumination control • Meter effect function • Information display
Trip computer switch	Transmits the following signals to the combination meter. <ul style="list-style-type: none"> • Enter switch signal • Select switch signal
Trip reset and illumination control switch	Transmits the following signals to the combination meter. <ul style="list-style-type: none"> • Trip reset switch signal • Illumination control switch signal (+) • Illumination control switch signal (-)
ECM	Transmits the following signals to the combination meter via CAN communication. <ul style="list-style-type: none"> • Engine speed signal • Engine coolant temperature signal • Engine status signal • Fuel consumption monitor signal
ABS actuator and electric unit (control unit)	Transmits the vehicle speed signal to the combination meter via CAN communication.
IPDM E/R	Transmits the oil pressure switch signal to the BCM via CAN communication.
BCM	Transmits the following signals to the combination meter via CAN communication. <ul style="list-style-type: none"> • Oil pressure switch signal • Position light request signal • Dimmer signal • Door switch signal • Meter ring illumination request signal • Starter relay status signal
TCM	Transmits the shift position signal to the combination meter via CAN communication.
A/T shift selector	Transmits the following signals to the combination meter. <ul style="list-style-type: none"> • Manual mode signal • Non-manual mode signal • Manual mode shift up signal • Manual mode shift down signal
Fuel level sensor unit	Transmits the fuel level sensor signal to the combination meter.
Oil pressure switch	Transmits the oil pressure switch signal to the IPDM E/R.
Ambient sensor	Transmits the ambient sensor signal to the combination meter.
A/C auto amp.	Transmits the A/C auto amp. connection recognition signal to the combination meter.
Parking brake switch	Transmits the parking brake switch signal to the combination meter.
Washer level switch	Transmits the washer level switch signal to the combination meter.

CLOCK

COMPONENT PARTS

< SYSTEM DESCRIPTION >

CLOCK : Component Parts Location

INFOID:000000009011897

1 : Clock

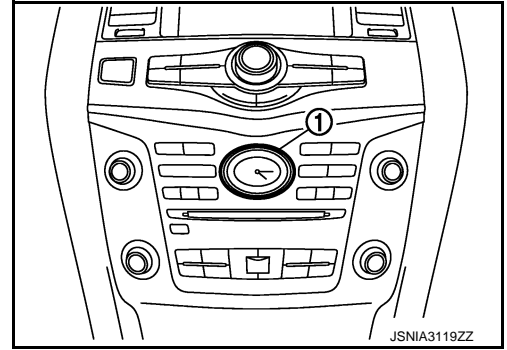

SYSTEM

< SYSTEM DESCRIPTION >

SYSTEM

METER SYSTEM

METER SYSTEM : System Diagram

INFOID:000000009011898

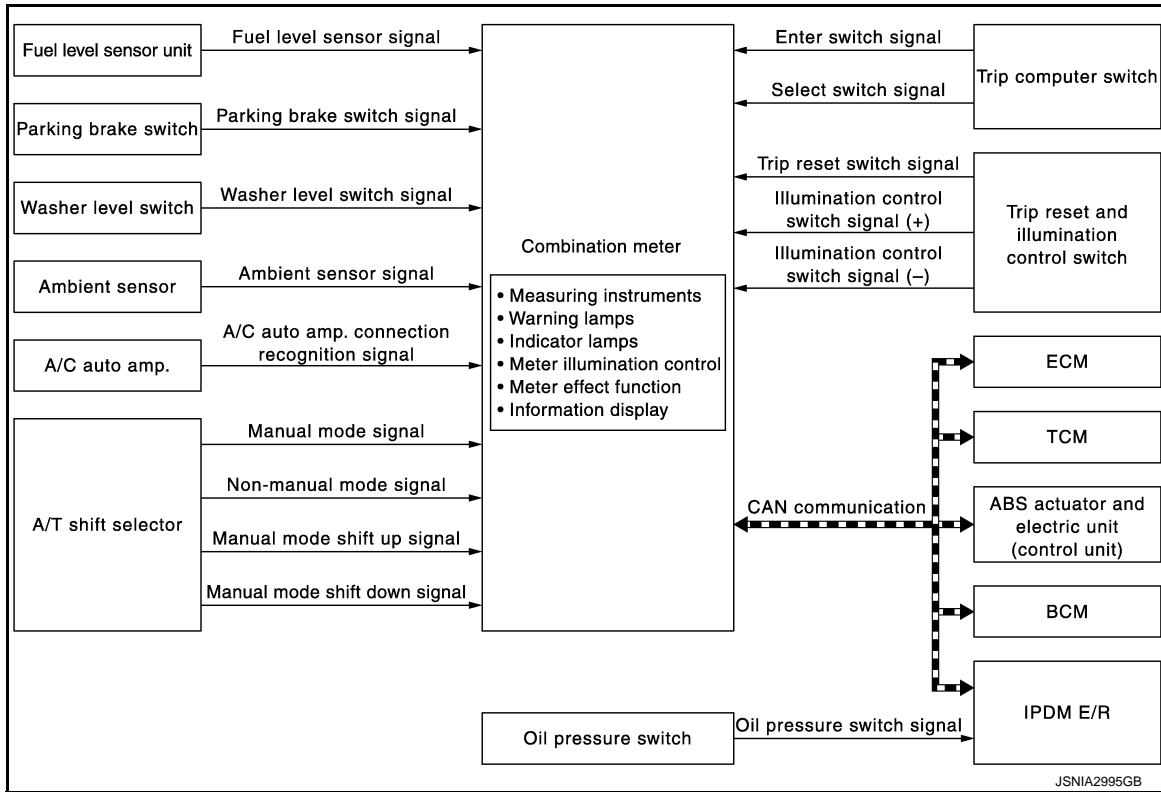

METER SYSTEM : System Description

INFOID:000000009011899

COMBINATION METER

- The combination meter receives necessary signals from each unit, switch, and sensor to control the following functions.
 - Measuring instruments
 - Warning lamps
 - Indicator lamps
 - Meter illumination control
 - Meter effect function
 - Information display
- The combination meter incorporates a buzzer function that sounds an audible alarm with the integrated buzzer device. Refer to [WCS-5, "Combination Meter"](#) for further details.
- The combination meter includes an on board diagnosis function.
- The combination meter can be diagnosed with CONSULT.

METER CONTROL FUNCTION LIST

SYSTEM

< SYSTEM DESCRIPTION >

	System	Description	Reference
Measuring instruments	Speedometer	Indicates vehicle speed.	MWI-13. "SPEEDOMETER : System Description"
	Tachometer	Indicates engine speed.	MWI-14. "TACHOMETER : System Description"
	Engine coolant temperature gauge	Indicates engine coolant temperature.	MWI-14. "ENGINE COOLANT TEMPERATURE GAUGE : System Description"
	Fuel gauge	Indicates fuel level.	MWI-14. "FUEL GAUGE : System Description"
	Engine oil pressure gauge	Indicates engine oil pressure.	MWI-15. "ENGINE OIL PRESSURE GAUGE : System Description"
	Voltmeter	Indicates voltage of ignition signal.	MWI-15. "VOLT-METER : System Description"
Warning lamp/indicator lamp	Oil pressure warning lamp	The warning lamp turns ON or turns OFF, according to engine hydraulic pressure.	MWI-16. "OIL PRESSURE WARNING LAMP : System Description"
	Master warning lamp	Turns ON/OFF in synchronization with a warning indicated on the information display.	MWI-16. "MASTER WARNING LAMP : System Description"
Meter illumination control	Meter illumination on/off control function	The meter illumination turns ON/OFF, according to the status of ignition switch and a cranking condition.	MWI-17. "METER ILLUMINATION CONTROL : System Description"
	Meter illumination control function	Switch mode between daytime mode and night time mode, according to a light switch position or ambient brightness.	
Meter effect function	Engine-start effect function	Controls pointers of combination meter and meter illumination at engine start to produce illumination effects.	MWI-18. "METER EFFECT FUNCTION : System Description"
	Driver welcome function	Controls meter illumination to produce illumination effects when getting in the vehicle.	

SYSTEM

< SYSTEM DESCRIPTION >

System		Description	Reference		
Information display	Odo/trip meter		Displays mileage.	A	
	Shift position indicator		Displays shift position.		
	Trip computer	Current fuel consumption		Displays current fuel consumption.	B
		Average fuel consumption		Displays average fuel consumption.	
		Distance to empty		Displays distance to empty.	C
		Average vehicle speed		Displays average vehicle speed.	
		Travel time		Displays travel time.	D
		Travel distance		Displays mileage.	
		Ambient temperature		Displays ambient temperature.	
	Interrupt indication	Warning	Door open warning	Warns when a door is open.	E
			Parking brake release warning	Warns if traveling when the parking brake is under operating condition.	
			Low tire pressure warning	Warns, according to tire inflation pressure.	F
			Fuel filler cap warning	Warns, according to the tightening condition of fuel filler cap.	
			Low fuel warning	Warns when being low on fuel.	G
			Low washer fluid warning	Displayed/Hidden, depending on washer fluid level.	
		Alert	Travel time	Causes an interrupt when exceeding randomly set time.	H
			Low ambient temperature	Causes an interrupt when ambient temperature reaches below 3 °C (37 °F).	I
		Maintenance	Tire	Causes an interrupt when exceeding randomly set distance.	J
			Oil filter	Causes an interrupt when exceeding randomly set distance.	
			Engine oil	Causes an interrupt when exceeding randomly set distance.	K
Other			Causes an interrupt when exceeding randomly set distance.		
Meter illumination level		Indicates the brightness of the meter illumination in stages.	L		
Setting	Alert	Timer	Allows the user to set a display time for "Travel time".	M	
		ICY	Allows the ON/OFF setting of the low ambient temperature (alert) function.		
	Maintenance	Tire	Alerts when reaching mileage set in "SETTING".	MWI	
		Filter	Alerts when reaching mileage set in "SETTING".		
		Oil	Alerts when reaching mileage set in "SETTING".	O	
		Other	Alerts when reaching mileage set in "SETTING".		
	Options	Language	Allows the user to set language for information display.		
		Unit	Allows unit settings.		
		Effects	Allows the ON/OFF setting of the engine-start effect function.	P	

MWI-20, "INFORMATION DISPLAY : System Description"

SYSTEM

< SYSTEM DESCRIPTION >

ARRANGEMENT OF COMBINATION METER

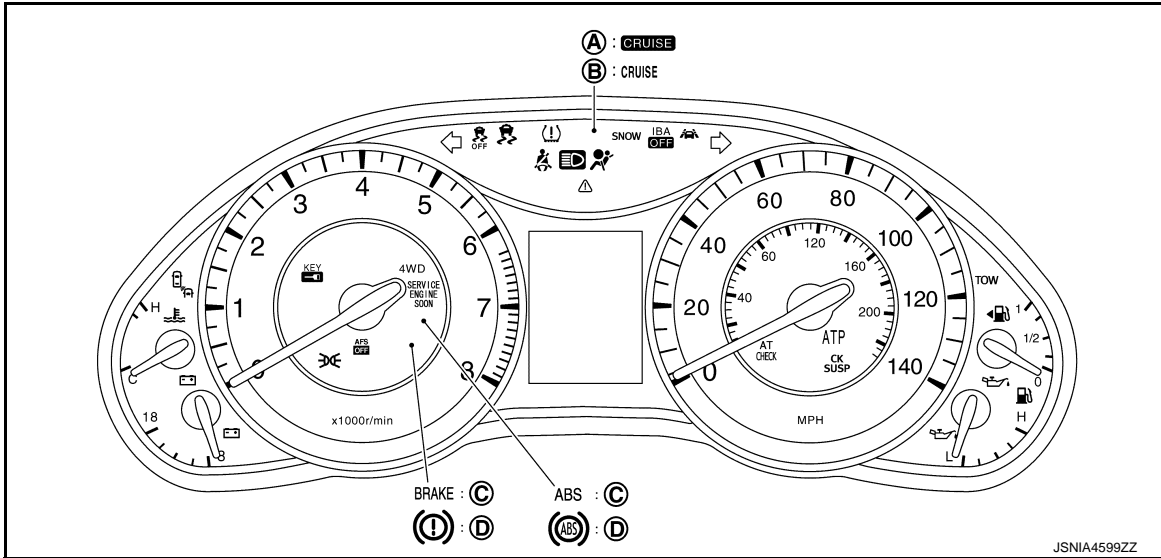

A. With ASCD models
D. Except for U.S.A.

B. With ICC models

C. For U.S.A.

METER SYSTEM : Fail-Safe

INFOID:000000009011900

FAIL-SAFE

The combination meter activates the fail-safe control if CAN communication with each unit is malfunctioning.

Function		Specifications
Speedometer		Reset to zero by suspending communication.
Tachometer		
Engine coolant temperature gauge		
Engine oil pressure gauge		
Illumination control		When suspending communication, changes to nighttime mode.
Information display	Odo/trip meter	An indicated value is maintained at communications blackout.
	Shift position indicator	The display turns OFF by suspending communication.
	Door open warning	The display turns OFF by suspending communication.
	Fuel filler cap warning	
	Low tire pressure warning	
Buzzer		The buzzer turns OFF by suspending communication.

SYSTEM

< SYSTEM DESCRIPTION >

Function	Specifications		
Warning lamp/indicator lamp	ABS warning lamp	The lamp turns ON by suspending communication.	A
	VDC warning lamp		B
	Brake warning lamp		C
	IBA OFF indicator lamp		D
	4WD warning lamp		E
	Malfunction indicator lamp		F
	VDC OFF indicator lamp		G
	CRUISE warning lamp		H
	Low tire pressure warning lamp	The lamp blinking caused by suspending communication.	I
	High beam indicator lamp		J
	Turn signal indicator lamp		K
	Position lamp indicator lamp		L
	A/T CHECK indicator lamp		M
	Key warning lamp		
	ATP warning lamp		
	Lane departure warning lamp		
	LDP ON indicator lamp		
	CRUISE indicator lamp		
	Oil pressure warning lamp		
	SNOW mode indicator lamp		
TOW mode indicator lamp			
CK SUSP indicator lamp			
Blind Spot Intervention ON indicator			
Blind Spot Warning/Blind Spot Intervention warning lamp			

SPEEDOMETER

SPEEDOMETER : System Diagram

INFOID:000000009011901

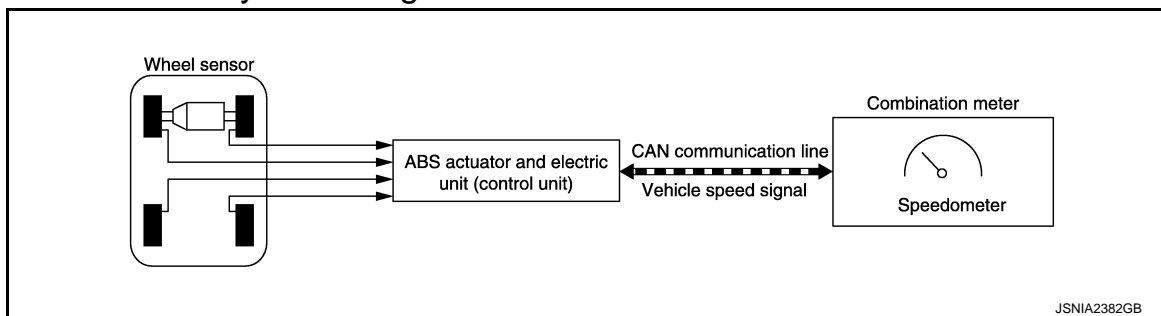

JSNIA2382GB

SPEEDOMETER : System Description

INFOID:000000009011902

- The ABS actuator and electric unit (control unit) converts the rectangular wave signal provided by the wheel sensor to a vehicle speed signal and transmits it to the combination meter via CAN communication.
- The combination meter indicates the vehicle speed to the speedometer according to the vehicle speed signal received via CAN communication.

TACHOMETER

SYSTEM

< SYSTEM DESCRIPTION >

TACHOMETER : System Diagram

INFOID:000000009011903

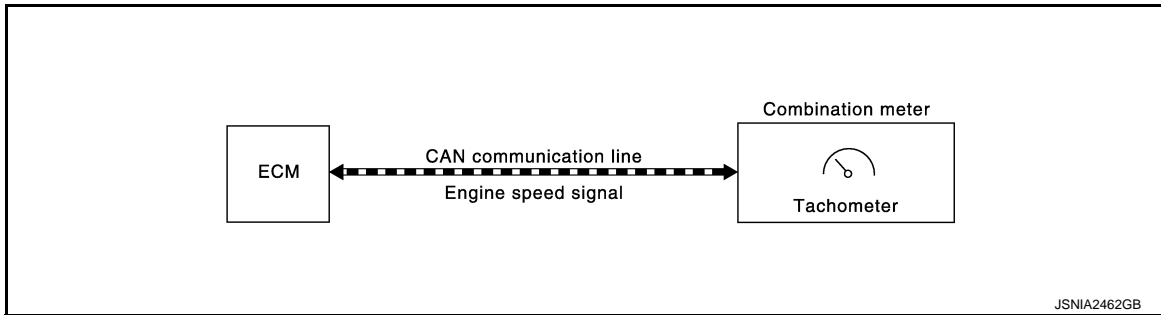

TACHOMETER : System Description

INFOID:000000009011904

- ECM converts the pulse signal provided by the crankshaft position sensor to an engine speed signal and transmits it to the combination meter via CAN communication.
- The combination meter indicates the engine speed to the tachometer according to the engine speed signal received via CAN communication.

ENGINE COOLANT TEMPERATURE GAUGE

ENGINE COOLANT TEMPERATURE GAUGE : System Diagram

INFOID:000000009011905

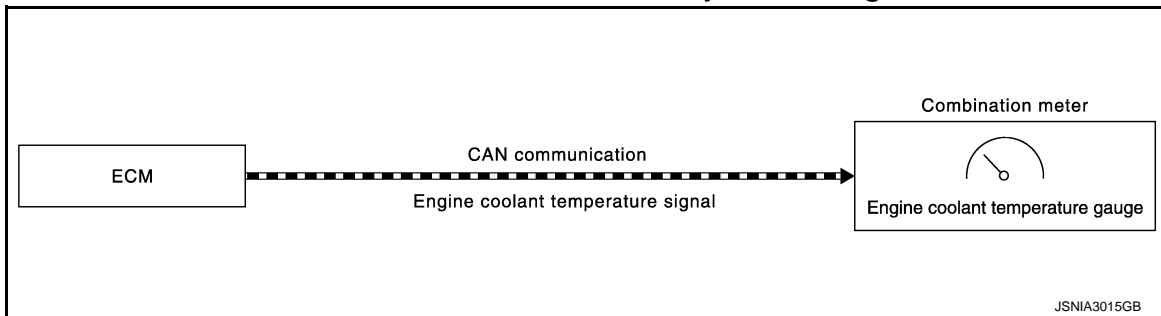

ENGINE COOLANT TEMPERATURE GAUGE : System Description

INFOID:000000009011906

- ECM reads the engine coolant temperature signal from the engine coolant temperature sensor and transmits the signal to the combination meter via CAN communication.
- The combination meter indicates the engine coolant temperature to the engine coolant temperature gauge according to the engine coolant temperature signal received via CAN communication.

FUEL GAUGE

FUEL GAUGE : System Diagram

INFOID:000000009011907

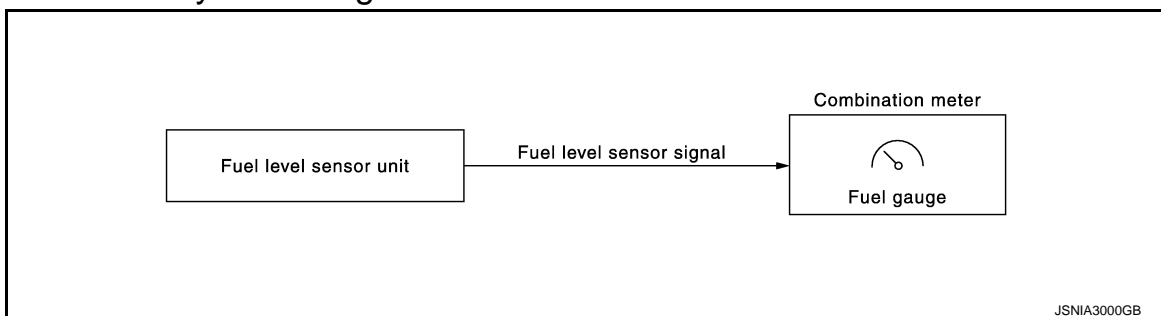

FUEL GAUGE : System Description

INFOID:000000009011908

CONTROL OUTLINE

The combination meter reads the fuel level sensor signal from the fuel level sensor unit and indicates the fuel level to the fuel gauge.

SYSTEM

< SYSTEM DESCRIPTION >

REFUEL CONTROL

The combination meter accelerates the fuel gauge if the all conditions listed below are met, or the ignition switch is ON from OFF.

- Ignition switch is ON position.
- The vehicle is not moving.
- The fuel level change by 15 ℓ (4 US gal, 3-1/4 Imp gal) or more.

ENGINE OIL PRESSURE GAUGE

ENGINE OIL PRESSURE GAUGE : System Diagram

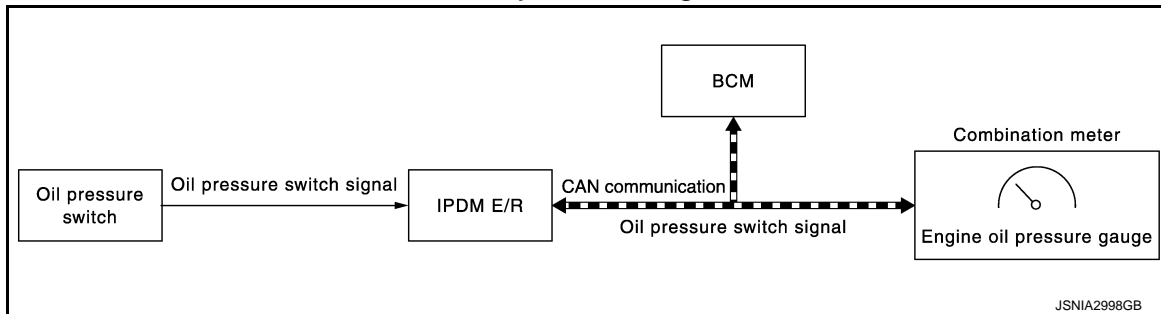

ENGINE OIL PRESSURE GAUGE : System Description

INFOID:000000009011910

- IPDM E/R reads the ON/OFF signals from the oil pressure switch and transmits the oil pressure switch signal to the combination meter via BCM with the CAN communication.
- The combination meter indicates engine oil pressure (Normal/Low) on the engine oil pressure gauge, based on an oil pressure switch signal received via CAN communication.

VOLTMETER

VOLTMETER : System Diagram

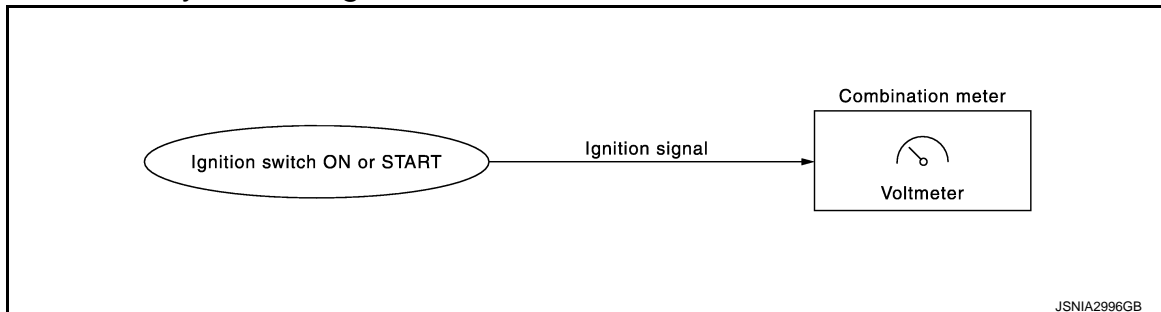

VOLTMETER : System Description

INFOID:000000009011912

The combination meter reads the voltage of an ignition signal and indicates the voltage on the voltmeter when the ignition switch is in ON or START position.

OIL PRESSURE WARNING LAMP

OIL PRESSURE WARNING LAMP : System Diagram

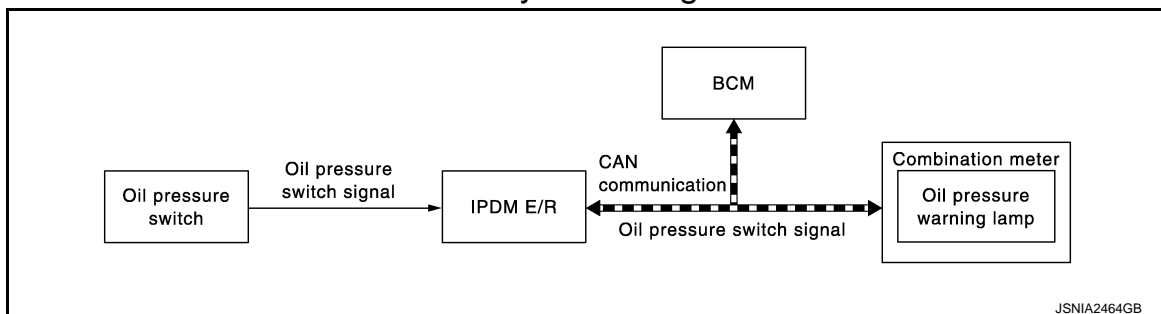

A
B
C
D
E
F
G
H
I
J
K
L
M
O
P

MWI

SYSTEM

< SYSTEM DESCRIPTION >

OIL PRESSURE WARNING LAMP : System Description

INFOID:000000009011914

- IPDM E/R reads the ON/OFF signals from the oil pressure switch and transmits the oil pressure switch signal to the combination meter via BCM with the CAN communication.
- The combination meter turns the oil pressure warning lamp ON (at the time of a reduction in hydraulic pressure)/OFF (except at the time of a reduction in hydraulic pressure) according to the oil pressure switch signal received via CAN communication.

MASTER WARNING LAMP

MASTER WARNING LAMP : System Diagram

INFOID:000000009011915

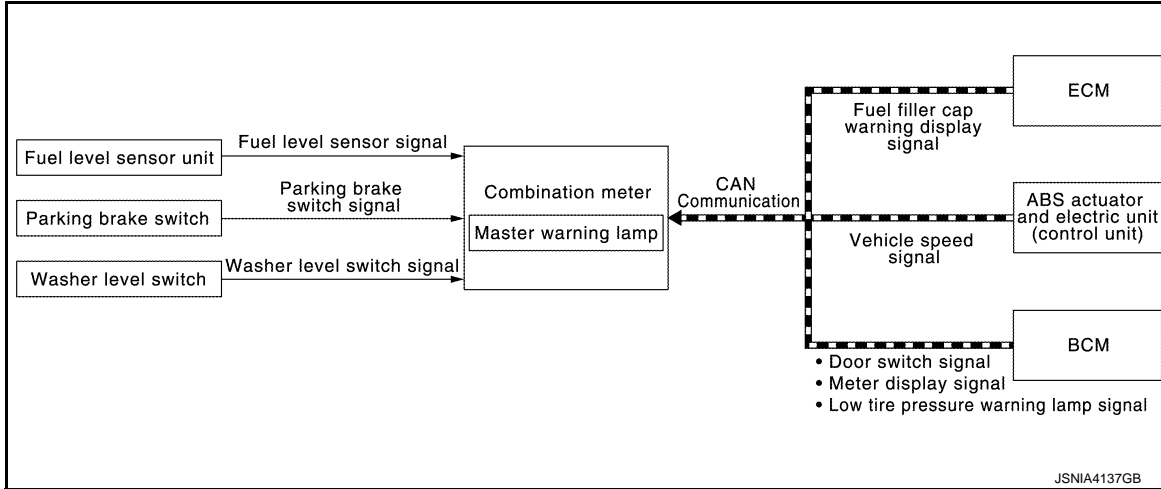

MASTER WARNING LAMP : System Description

INFOID:000000009011916

When receiving a signal from each unit, switch, or sensor, the combination meter turns ON/OFF the master warning lamp in synchronization with the following warnings on the information display:

- Door open warning
- Parking brake release warning
- Low fuel warning
- Low washer fluid warning
- NO KEY warning
- Low tire pressure warning
- Fuel filler cap warning

NOTE:

For details on warnings displayed on the vehicle information display, refer to [MWI-20, "INFORMATION DISPLAY : System Description"](#).

METER ILLUMINATION CONTROL

METER ILLUMINATION CONTROL : System Diagram

INFOID:000000009011917

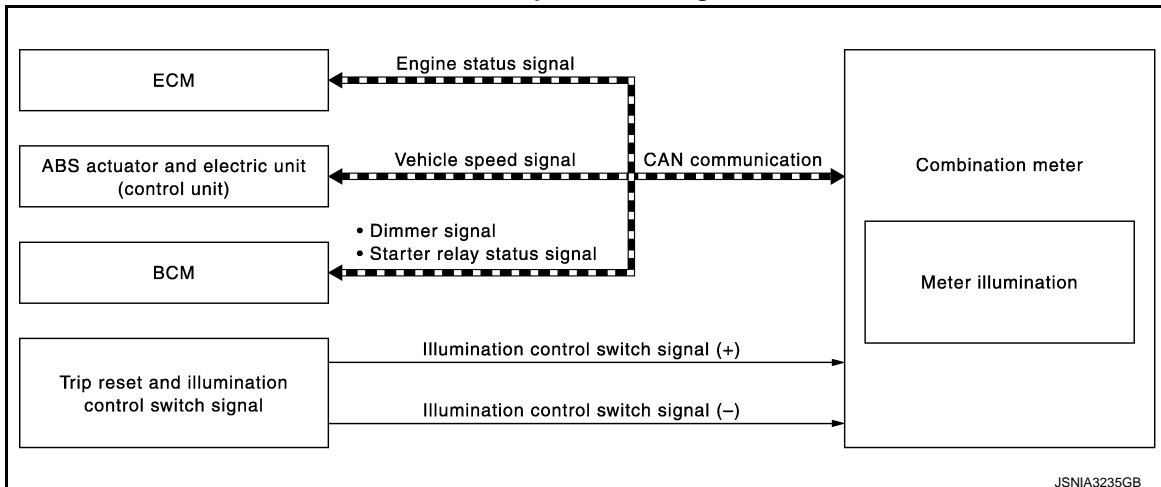

SYSTEM



< SYSTEM DESCRIPTION >

METER ILLUMINATION CONTROL : System Description

INFOID:000000009011918

METER ILLUMINATION ON/OFF CONTROL FUNCTION

- Combination meter turns ON meter illumination when the following condition is satisfied:
 - Ignition switch ON
- Combination meter turns OFF meter illumination when any of the following condition is satisfied:
 - During a crank with vehicle speed less than 1 km/h (0.6 MPH)
 - Ignition switch OFF or ACC
- The combination meter receives the following signals to control meter illumination.

Signal name	Signal path
Ignition signal	—
Engine status signal	ECM  Combination meter
Vehicle speed signal	ABS actuator and control unit (control unit)  Combination meter
Starter relay status signal	BCM  Combination meter

METER ILLUMINATION CONTROL FUNCTION

- The combination meter controls meter illumination, based on the following signal.
 - Dimmer signal
- The combination meter switches mode between Daytime mode and Nighttime mode, according to the following conditions.

Combination switch (lighting switch)	Condition		Meter illumination
	1ST or 2ND position	Outdoor: Bright*	Outdoor: Bright*
Outdoor: Dark*			Nighttime mode
AUTO POSITION		Outdoor: Bright*	Daytime mode
		Outdoor: Dark*	Nighttime mode
Off			Daytime mode

*: For further information, refer to [INL-11, "AUTO LIGHT ADJUSTMENT SYSTEM : System Description"](#).

- The operation of the illumination control switch allows the brightness adjustment of meter illumination.

Meter illumination	The number of adjustable steps
Daytime	22 steps
Nighttime	22 steps

METER EFFECT FUNCTION

A
B
C
D
E
F
G
H
I
J
K
L
M
O
P

MWI

SYSTEM

< SYSTEM DESCRIPTION >

METER EFFECT FUNCTION : System Diagram

INFOID:000000009011919

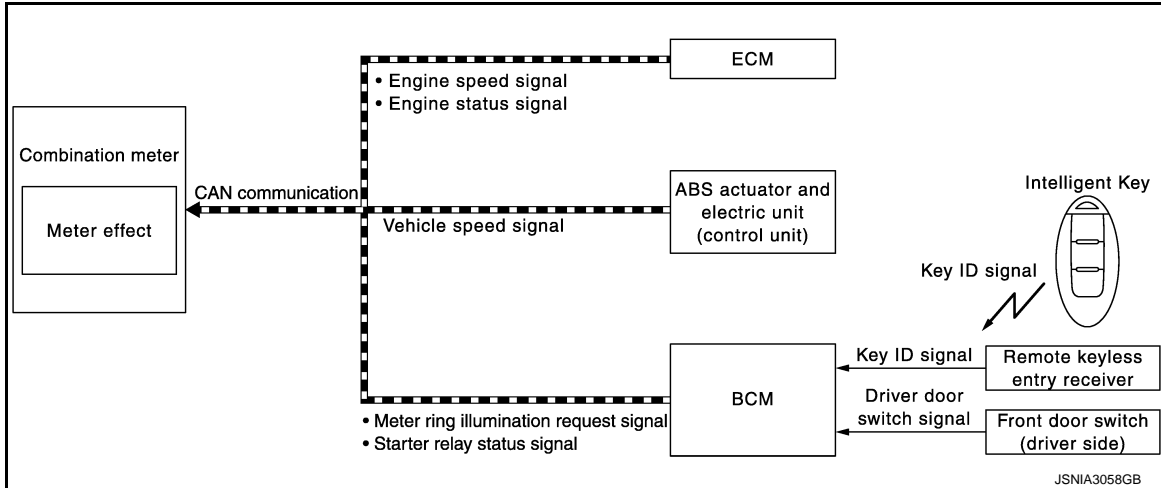

METER EFFECT FUNCTION : System Description

INFOID:000000009011920

ENGINE-START EFFECT FUNCTION

When recognizing an engine start, the combination meter controls the following items for producing the effect.

- Speedometer
- Tachometer
- Engine coolant temperature gauge
- Fuel gauge
- Engine oil pressure gauge
- Voltmeter
- Meter illumination

Meter and Illumination Operations During Engine-start Effect

The combination meter controls the following items during the engine-start effect.

Control item		Operation
Speedometer		Sweeps the pointer.
Tachometer		Sweeps the pointer.
Engine coolant temperature gauge		Stops the pointer.
Fuel gauge		Stops the pointer.
Engine oil pressure gauge		Stops the pointer.
Voltmeter		Stops the pointer.
Meter illumination	Pointers	Turns on the illumination at the effect level.
	Information display	Turns on the illumination at the normal brightness level.
	Other than those above	Increases the brightness to the effect level in stages.

NOTE:

The pointers are stopped and illumination is turned off while cranking the engine.

Engine Start Judgement

The combination meter judges "engine-start" and activates the engine-start effect only once when the following operational conditions are all satisfied.

Condition	
Ignition switch	ON position
Vehicle speed	Less than 1 km/h (0.6 MPH)

SYSTEM

< SYSTEM DESCRIPTION >



Condition	
Engine state	Other than the time of cranking the engine 500 rpm or more
Information display (SETTING)	The setting of "EFFECT" is "ON."

NOTE:

Engine-start effect exits when any of the above operational conditions is cancelled during the engine-start effect.

Signal path

The combination meter judges "engine-start," according to the following signals and activates the engine-start effect function.

Signal name	Signal path
Ignition signal	—
Starter relay status signal	BCM  Combination meter
Engine speed signal	ECM  Combination meter
Engine status signal	
Vehicle speed signal	ABS actuator and electric unit (control unit)  Combination meter

DRIVER WELCOME FUNCTION

BCM transmits a meter ring illumination request signal to the illumination meter when all the following operational conditions are satisfied. When receiving the meter ring illumination request signal from BCM via CAN communication, the combination meter increases illumination brightness of the combination meter to the set brightness level in stages. After a certain period of time, the meter illumination gradually dims to be turned OFF.

Operational condition	
Ignition switch	LOCK position
Driver door	Open→Close*

*: Close the driver side door with the intelligent key left inside the vehicle.

Timing Chart

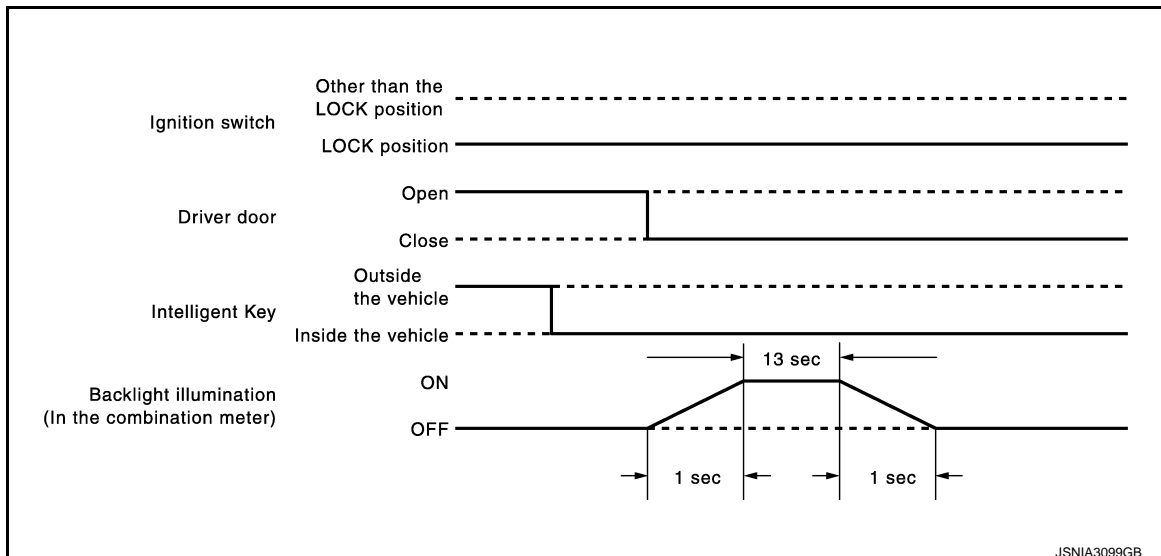

INFORMATION DISPLAY

SYSTEM

< SYSTEM DESCRIPTION >

INFORMATION DISPLAY : System Diagram

INFOID:000000009011921

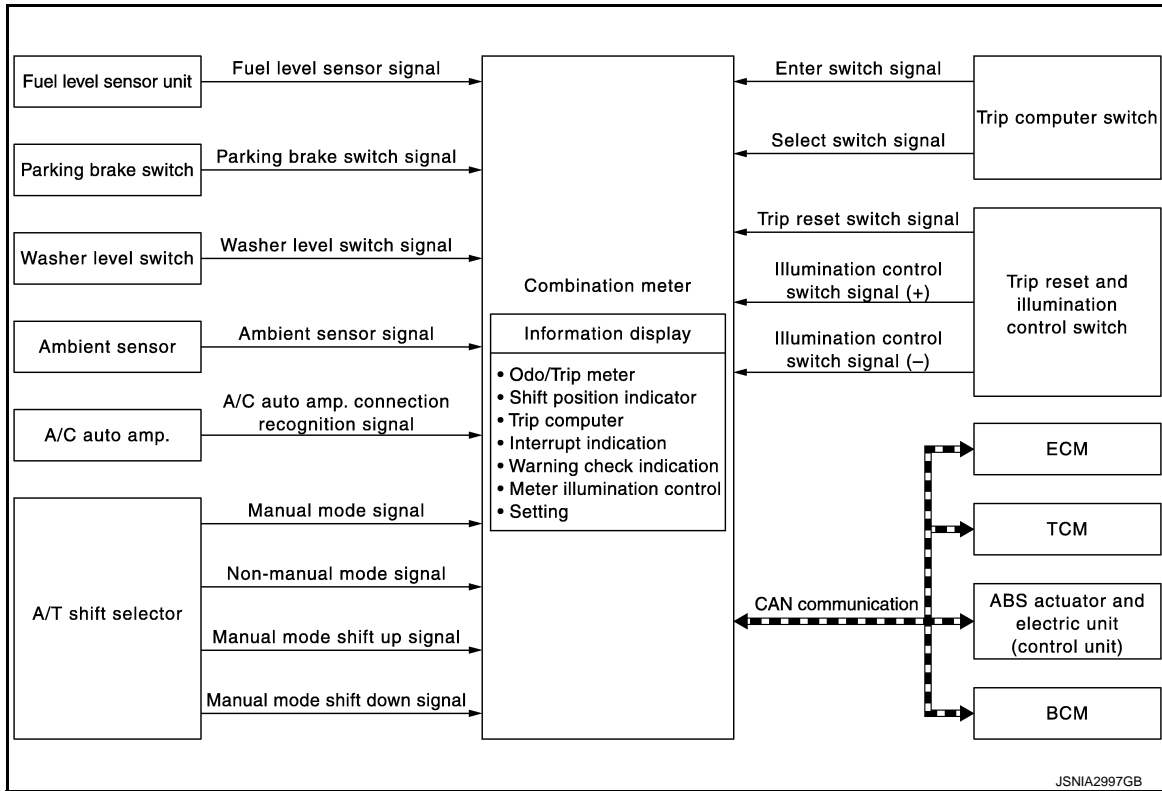

INFORMATION DISPLAY : System Description

INFOID:000000009011922

DESCRIPTION

- The combination meter receives signals necessary for controlling the operation of the information display from each unit, sensor and switch.
- The combination meter incorporates a trip computer that displays the warning/information according to the information received from each unit, sensor and switch.
- The combination meter shows the following functions on the information display.
 - Odo/trip meter
 - Shift position indicator
 - Trip computer
 - Interrupt indication
 - Warning check indication
 - Setting

ODO/TRIP METER

- The ABS actuator and electric unit (control unit) reads the rectangular wave signal provided by the wheel sensor and transmits the vehicle speed signal to the combination meter via CAN communication.
- The combination meter converts the vehicle speed signal received via CAN communication to mileage, and it displays the accumulated mileage on the information display.

SHIFT POSITION INDICATOR

MANUAL MODE

- The combination meter receives the following signal and transmits the signal to TCM via CAN communication.

SYSTEM

< SYSTEM DESCRIPTION >

Signal name	Signal path
Manual mode signal	
Non-manual mode signal	
Manual mode shift up signal	
Manual mode shift down signal	

- TCM judges a shift position, manual mode, and manual mode information, based on a signal received from the combination meter via CAN communication and transmits the following signals to the combination meter via CAN communication.

Signal name	Signal path
Shift position signal	
Manual mode shift refusal signal	

- The combination meter activates the shift position indicator, and manual mode information, based on signals received from TCM via CAN communication.

NOTE:

When receiving a manual mode shift refusal signal from TCM via CAN communication, the combination meter blinks the shift position indicator lamp and allows the integrated buzzer to ring a beep tone. For further information, refer to [TM-56. "SHIFT PATTERN CONTROL : System Description"](#).

NON-MANUAL MODE

- Combination meter inputs non-manual mode signal from A/T shift selector (manual mode switch), and transmits the signals to TCM with CAN communication line.
- TCM transmits shift position signal to combination meter with CAN communication line.
- Combination meter indicates shift position when receiving shift position signal.

TRIP COMPUTER

Current Fuel Consumption

The combination meter calculates current fuel consumption based on the following signals, and the calculated value is displayed on the information display.

Signal name	Signal path
Fuel consumption monitor signal	
Vehicle speed signal	

NOTE:

- Current fuel consumption on the information display is updated approximately every 0.5 seconds.
- Current fuel consumption on the information display shows 0 l/100km (0 mpg) when vehicle speed is 0 km/h (0 MPH).

Average Fuel Consumption

The combination meter calculates average fuel consumption based on the following signals, and the calculated value is displayed on the information display.

Signal name	Signal path
Fuel consumption monitor signal	
Vehicle speed signal	

NOTE:

- Average fuel consumption on the information display is updated approximately every 30 seconds.
- Soon after a reset or when the ignition switch is turned ON right after battery removal and installation, “—” is displayed until after a travel of 30 seconds and approximately 500 m (0.31 mile).

A
B
C
D
E
F
G
H
I
J
K
L
M

MWI





O
P

SYSTEM

< SYSTEM DESCRIPTION >

Distance to Empty

The combination meter calculates distance to empty based on the following signals, and the calculated value is displayed on the information display.



Signal name	Signal path
Fuel level sensor signal	Fuel level sensor unit  Combination meter
Fuel consumption monitor signal	ECM   Combination meter
Vehicle speed signal	ABS actuator and electric unit (control unit)   Combination meter

NOTE:

- Distance to empty on the information display is updated approximately every 30 seconds.
- When the ignition switch is turned from OFF to ON, “—” is displayed until after a travel of approximately 500 m (0.31 mile).
- The indicated values may not match each other when refueling with the ignition switch ON.

Average Vehicle Speed

The combination meter calculates average vehicle speed based on the following signals, and the calculated value is displayed on the information display.

Signal name	Signal path
Ignition signal	—
Vehicle speed signal	ABS actuator and electric unit (control unit)   Combination meter

NOTE:



- Average vehicle speed on the information display is updated approximately every 30 seconds.
- Soon after a reset or when the ignition switch is turned ON right after battery removal and installation, “—” is displayed until after a 30 seconds.

Travel Time

The combination meter measures and displays travel time (ignition switch ON time).





Travel Distance

The combination meter calculates mileage, based on the following signals and displays the mileage on the information display.

Signal name	Signal path
Ignition signal	—
Vehicle speed signal	ABS actuator and electric unit (control unit)   Combination meter

Ambient Temperature

- The combination meter corrects an indicated temperature, based on various signals.
- The combination meter calculates ambient air temperature based on the following signals, and the calculated value is displayed on the information display.

Signal name	Signal path
Ignition signal	—
Ambient sensor signal	Ambient sensor  Combination meter
A/C auto amp. connection recognition signal	A/C auto amp.  Combination meter
Vehicle speed signal	ABS actuator and electric unit (control unit)   Combination meter

Correction Process (Temperature indicated soon after the ignition switch ON)

SYSTEM

< SYSTEM DESCRIPTION >

- A temperature indicated soon after the ignition switch is turned ON depends on the time from the ignition switch OFF to ON and a temperature detected by the ambient sensor. A

When any condition described below is met, an ambient sensor-detected temperature is indicated.

- Time from the ignition switch OFF to ON \geq Predetermined time B
- Sensor-detected temperature < Temperature at the last ignition switch OFF

Correction Process (Temperature at the Ignition switch ON)

- A temperature indicated when the ignition switch is ON depends on a vehicle speed, an ambient sensor-detected temperature, and traveling time. C

The temperature on the information display is corrected to an ambient sensor-detected temperature when the following condition is met.

- Ambient sensor-detected temperature < Temperature on the information display D

A temperature on the information display is not updated when the following condition is met.

- Ambient sensor-detected temperature \geq Temperature on the information display E
- Vehicle speed \leq 20 km/h (12 MPH)

A temperature on the information display slowly rises to an ambient sensor-detected temperature when the following condition is met.

- Ambient sensor-detected temperature \geq Temperature on the information display F
- Vehicle speed \geq 20 km/h (12 MPH)

A temperature on the information display rapidly rises to an ambient sensor-detected temperature when the following condition is met.

- Ambient sensor-detected temperature \geq Temperature on the information display G
- Vehicle speed \geq 20 km/h (12 MPH)
- When driving more than set time H

A/C auto amp. connection recognition

- The combination meter judges the A/C auto amp. connection/disconnection, based on an A/C auto amp. connection recognition signal to judge the presence/absence of the ambient sensor power output. I

NOTE:

- After an ignition switch is turned ON, “—” is displayed until after a 2.5 seconds. J
- The ambient sensor input value that is displayed on “Data Monitor” of CONSULT is the value before the correction. It may not match the indicated temperature on the information display.
- After removal and installation of the battery and combination meter, an ambient sensor-detected temperature is indicated on the information display. K
- Depending on engine heat or heat on the road surfaces, an ambient temperature may be indicated higher than actual one.

INTERRUPT INDICATION

- The combination meter displays an interrupt regarding a warning, alert, and maintenance on the information display, based on signals received from each unit and switch. L
- When conditions are satisfied, the normal screen switches to a warning screen to display an interrupt. M

Door Open Warning

- When all the following operating conditions are satisfied, the combination meter displays a door open warning on the information display by an interrupt. MWI

Operating condition	
Ignition switch	ON
Door	Any door is open

- The combination meter judges showing/hiding of “door open warning”, according to the signals below: O

Signal name	Signal path
Ignition signal	—
Door switch signal	Door switch \longrightarrow BCM $\xrightarrow{\text{CAN}}$ Combination meter P

Parking Brake Release Warning

SYSTEM

< SYSTEM DESCRIPTION >

- When all the following operating conditions are satisfied, the combination meter displays a parking brake release warning on the information display by an interrupt.

Operating condition	
Ignition switch	ON
Parking brake	Applied
Vehicle speed	7 km/h (4.3 MPH) or more

- The combination meter judges showing/hiding of “parking brake release warning”, according to the signals below:

Signal name	Signal path
Ignition signal	—
Parking brake switch signal	Parking brake switch → Combination meter
Vehicle speed signal	ABS actuator and electric unit (control unit)  → Combination meter

Low Fuel Warning

- When all the following operating conditions are satisfied, the combination meter displays a low fuel warning on the information display by an interrupt.

Operating condition	
Ignition switch	ON
Fuel remaining quantity*	Approximately 15.0 ℓ (4 US gal, 3-1/4 Imp gal) or less (including fuel remained)

*: With the vehicle in a horizontal position

- The combination meter judges showing/hiding of “low fuel warning”, according to the signals below:

Signal name	Signal path
Ignition signal	—
Fuel level sensor signal	Fuel level sensor → Combination meter

Low Washer Fluid Warning

- When all the following operating conditions are satisfied, the combination meter displays a low washer fluid warning on the information display by an interrupt.

Operating condition	
Ignition switch	ON
Washer level switch	Decrease in fluid level (washer level switch ON for 180 seconds or more)

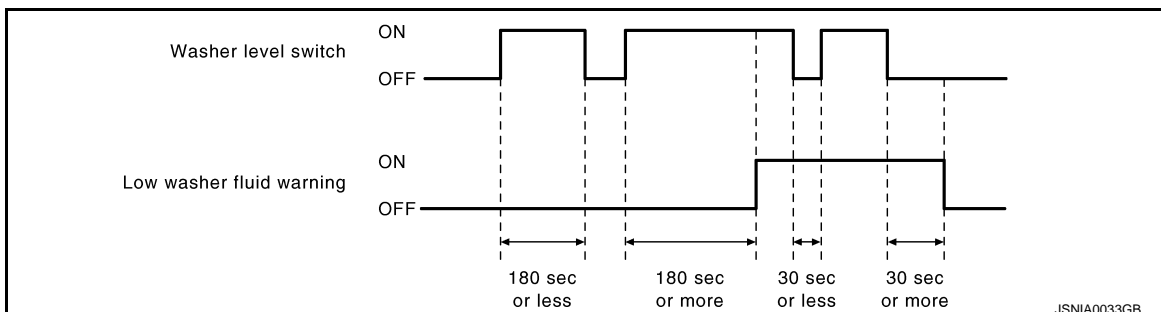

- The combination meter judges showing/hiding of “low washer fluid warning”, according to the signals below:

SYSTEM

< SYSTEM DESCRIPTION >

Signal name	Signal path
Ignition signal	—
Washer level switch signal	Washer level switch Combination meter

Fuel Filler Cap Warning

- The combination meter judges showing/hiding of “fuel filler cap warning”, according to the signals below:

Signal name	Signal path
Ignition signal	—
Fuel filler cap warning display signal	ECM Combination meter

- For further information, refer to [EC-54, "FUEL FILLER CAP WARNING SYSTEM : System Description"](#).

Low Tire Pressure Warning

- The combination meter judges showing/hiding of “low tire pressure warning”, according to the signals below:

Signal name	Signal path
Ignition signal	—
Low tire pressure warning lamp signal	BCM Combination meter

- For further information, refer to [WT-9, "System Description"](#).

Travel Time (Alert)

- When all the following operating conditions are satisfied, the combination meter displays a travel time on the information display by an interrupt.

Operating condition	
Ignition switch	Switch-ON time

- The combination meter judges showing/hiding of “travel time”, according to the signals below:

Signal name	Signal path
Ignition signal	—

Low Ambient Temperature (Alert)

- When all the following operating conditions are satisfied, the combination meter displays a low ambient temperature on the information display by an interrupt.

Operating condition	
Ignition switch	ON
ambient temperature	3 °C (37 °F) or less
information display	“ON” is selected in “SETTING”

- The combination meter judges showing/hiding of “low ambient temperature”, according to the signals below:

Signal name	Signal path
Ignition signal	—
Ambient sensor signal	Ambient sensor Combination meter

Tire (Maintenance)

- When all the following operating conditions are satisfied, the combination meter displays a tire warning on the information display by an interrupt.

A
B
C
D
E
F
G
H
I
J
K
L
M
O
P

MWI

SYSTEM

< SYSTEM DESCRIPTION >

Operating condition	
Ignition switch	ON
Mileage	More than value set in "SETTING"

- The combination meter judges showing/hiding of "tire warning", according to the signals below:

Signal name	Signal path
Ignition signal	—
Vehicle speed signal	ABS actuator and electric unit (control unit) → Combination meter

Oil Filter (Maintenance)

- When all the following operating conditions are satisfied, the combination meter displays an oil filter warning on the information display by an interrupt.

Operating condition	
Ignition switch	ON
Mileage	More than value set in "SETTING"

- The combination meter judges showing/hiding of "oil filter warning", according to the signals below:

Signal name	Signal path
Ignition signal	—
Vehicle speed signal	ABS actuator and electric unit (control unit) → Combination meter

Engine Oil (Maintenance)

- When all the following operating conditions are satisfied, the combination meter displays an engine oil warning on the information display by an interrupt.

Operating condition	
Ignition switch	ON
Mileage	More than value set in "SETTING"

- The combination meter judges showing/hiding of "engine oil warning", according to the signals below:

Signal name	Signal path
Ignition signal	—
Vehicle speed signal	ABS actuator and electric unit (control unit) → Combination meter

Other (Maintenance)

- When all the following operating conditions are satisfied, the combination meter displays an other warning on the information display by an interrupt.

Operating condition	
Ignition switch	ON
Mileage	More than value set in "SETTING"

- The combination meter judges showing/hiding of "other warning", according to the signals below:

SYSTEM

< SYSTEM DESCRIPTION >

Signal name	Signal path
Ignition signal	—
Vehicle speed signal	ABS actuator and electric unit (control unit)  → Combination meter

Meter Illumination Level Indication

When receiving the following signals, the combination meter causes an interrupt on the information display to indicate an illumination level.

Signal name	Signal path
Ignition signal	—
Illumination control switch signal (+)	Trip reset and illumination control switch  → Combination meter
Illumination control switch signal (-)	

WARNING CHECK INDICATION

- The combination meter can cause an interrupt on the information display to indicate a warning, based on signals received from each unit and switch.
- The indicated warning can be checked with “WARNING” during the satisfaction of an interrupt indication condition for each warning.

SETTING

Warning indication timing and time can be set.

Alert

Setting values for travel time, and low ambient temperature can be adjusted to meet the user's needs.

Setting item	Setting range	Setting unit
Alert	Timer	No setting, 0.5 h - 6 h
	ICY	ON/OFF

Maintenance

Setting values for engine oil, oil filter, tire, and other maintenance items can be adjusted to meet the user's needs.

Setting item	Setting range	
Maintenance	Tire	No setting, 500 km - 30,000 km (No setting, 250 mile - 18,500 mile)
	Filter	No setting, 500 km - 30,000 km (No setting, 250 mile - 18,500 mile)
	Oil	No setting, 500 km - 30,000 km (No setting, 250 mile - 18,500 mile)
	Other	No setting, 500 km - 30,000 km (No setting, 250 mile - 18,500 mile)

Options

Setting values for unit and effect items can be adjusted to meet the user's needs.

A
B
C
D
E
F
G
H
I
J
K
L
M
N
O
P

MWI

SYSTEM

< SYSTEM DESCRIPTION >

Setting item		
Options	Language	English
		Francais
		Espanol
	Unit	Miles, MPG, °F
		km, l/100 km, °C
	Effects	ON/OFF

Settings-reject Indication

- Regarding settings-reject indications, “SETTING CAN BE OPERATED WHEN STOPPED” is shown on the information display when indication conditions are satisfied.
- When reaching 5 km/h (3.1 MPH) after accelerating from a stopping condition, a settings-reject indication is displayed.
- When reaching less than 1 km/h (0.6 MPH) after decelerating from 5 km/h (3.1 MPH), a settings-reject indication is cancelled to allow settings.
- The combination meter judges a vehicle condition based on the following signals and displays a settings-reject indication on the information display.

Signal name	Signal path
Ignition signal	—
Vehicle speed signal	ABS actuator and electric unit (control unit)  Combination meter

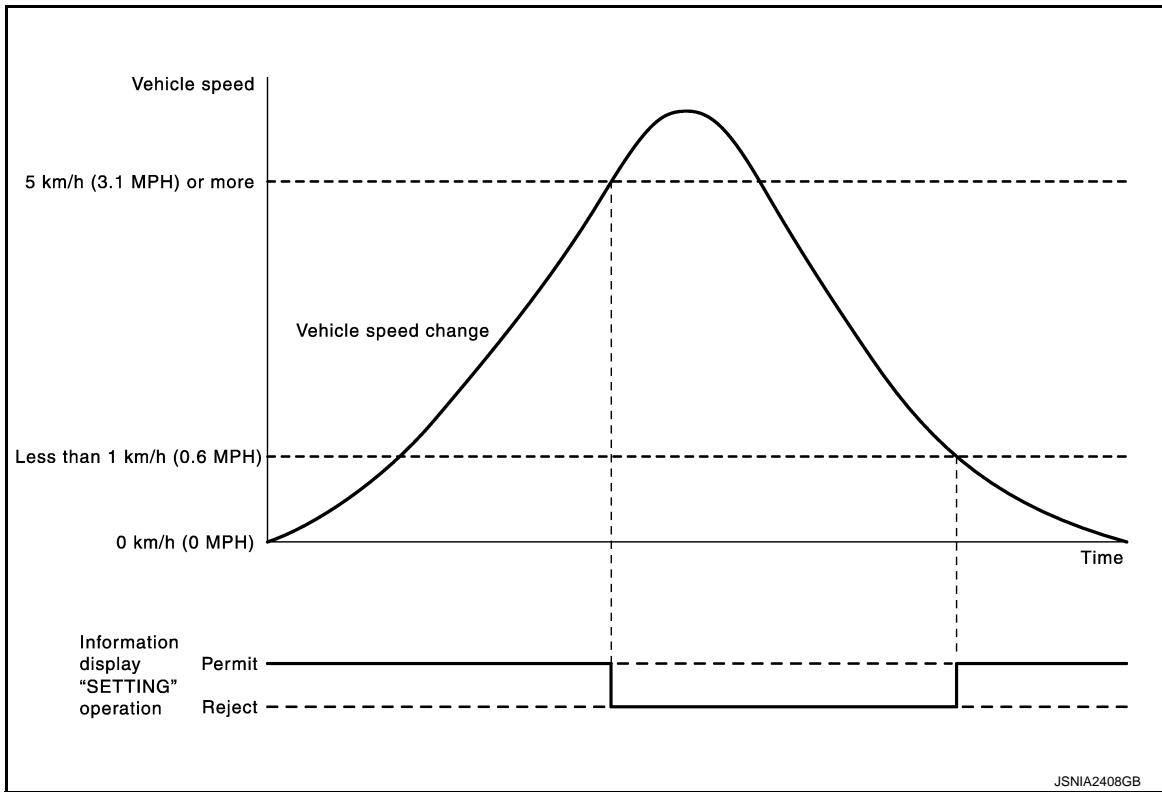

OPERATION

< SYSTEM DESCRIPTION >

OPERATION

Switch Name and Function

INFOID:000000009011923

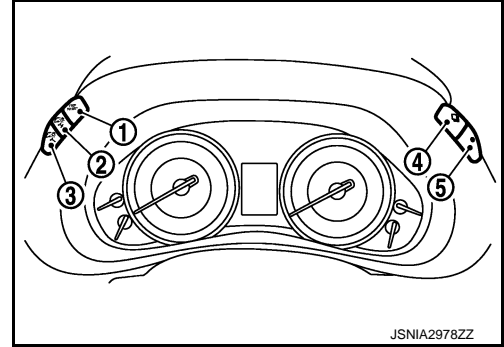

Switch name		Operation	Description
Trip reset and illumination control switch	Trip reset switch (1)	Press	<ul style="list-style-type: none"> The trip meter can be switched between A and B. Trip meter A/B can be reset by pressing and holding the trip reset switch.
	Illumination control switch (+) (2)		An illuminance level of the back light of the combination meter can be adjusted.
	Illumination control switch (-) (3)		
Trip computer switch	Enter switch (4)		<ul style="list-style-type: none"> The information display screen can be switched. The item indicated on the information display can be confirmed. An indicated value of the trip computer can be reset by pressing and holding the enter switch.
	Select switch (5)		When plural items are shown on the information display, a selected item can be changed to the other item.

A
B
C
D
E
F
G
H
I
J
K
L
M
O
P

MWI

DIAGNOSIS SYSTEM (COMBINATION METER)

< SYSTEM DESCRIPTION >

DIAGNOSIS SYSTEM (COMBINATION METER)

On Board Diagnosis Function

INFOID:000000009011924

ON BOARD DIAGNOSIS ITEM

The combination meter allows the following diagnosis items with the on-board diagnosis function.

Diagnosis item	
Drive circuit check	<ul style="list-style-type: none">• Speedometer• Tachometer• Engine coolant temperature gauge• Fuel gauge• Engine oil pressure gauge• Voltmeter
LCD (liquid crystal display) check	Information display

METHOD OF STARTING

1. Turn ignition switch OFF.
2. While pressing the trip reset switch (1), turn ignition switch ON.
3. If the diagnosis function is activated with "trip A" displayed, the mileage on "trip A" is reset to "0000.0". (The same way for "trip B".)

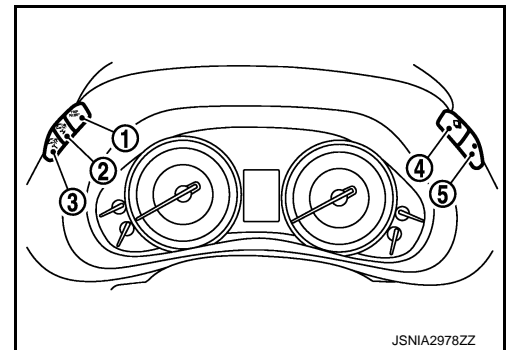

4. Make sure that the trip meter displays "0000.0".
5. Press the trip reset switch at least 3 times. (Within 7 seconds after the ignition switch is turned ON.)
6. The combination meter is turned to self-diagnosis mode.
 - Speedometer, tachometer, engine coolant temperature gauge, fuel gauge, engine oil pressure gauge, and voltmeter return to zero, simultaneously.
 - The dot matrix dots on the information display (1) blink alternately.

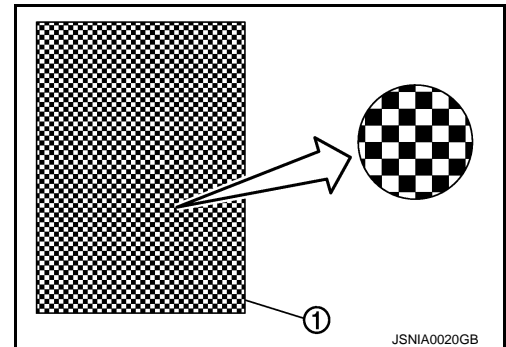

NOTE:

- Check combination meter power supply and ground circuit when the self-diagnosis mode of the combination meter does not start. Replace combination meter if power supply and ground circuit are normal.
- If any of the dots are not displayed, replace combination meter.

DIAGNOSIS SYSTEM (COMBINATION METER)

< SYSTEM DESCRIPTION >

7. Each meter activates by pressing the trip reset switch.

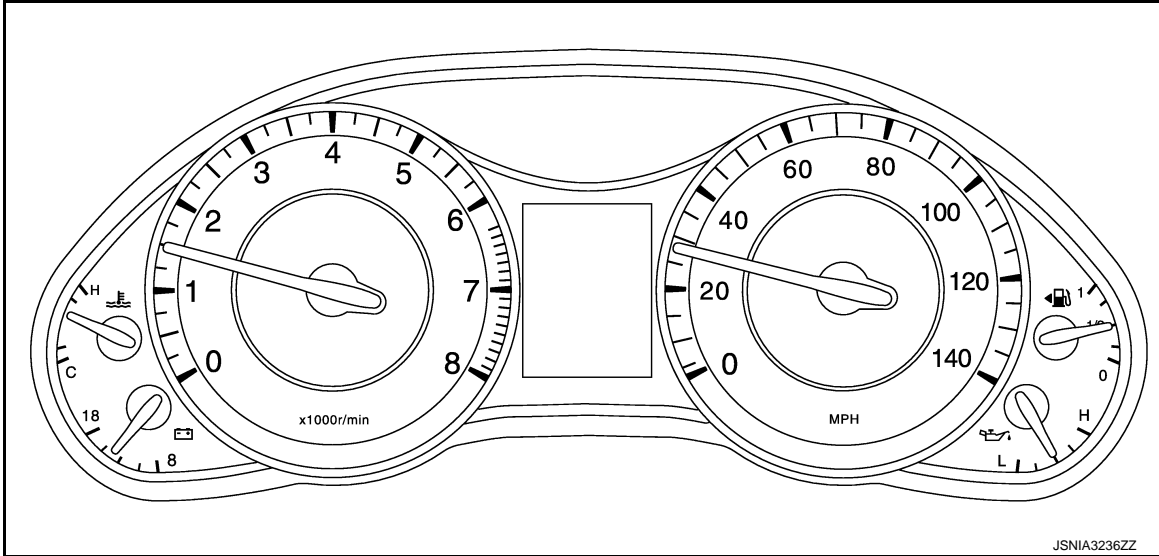

NOTE:

- If any of the meters or gauges is not activated, replace combination meter.
- The figure is reference.

CONSULT Function

INFOID:000000009011925

CONSULT APPLICATION ITEMS

CONSULT can perform the following diagnosis modes via CAN communication and the combination meter.

System	Diagnosis mode	Description
METER/M&A	Self Diagnostic Result	The combination meter checks the conditions and displays memorized errors.
	Data Monitor	Displays the combination meter input/output data in real time.
	Warning History	Lighting history of the warning lamp and indicator lamp can be checked.

SELF DIAG RESULT

Refer to [MWI-44, "DTC Index"](#).

DATA MONITOR

NOTE:

The following table includes information (items) inapplicable to this vehicle. For information (items) applicable to this vehicle, refer to CONSULT display items.

Display Item List

X: Applicable

Display item [Unit]	MAIN SIGNALS	Description
SPEED METER [km/h]	X	Value of vehicle speed signal received from ABS actuator and electric unit (control unit) via CAN communication. NOTE: 655.35 is displayed when the malfunction signal is received.
SPEED OUTPUT [km/h]	X	Vehicle speed signal value transmitted to other units via CAN communication. NOTE: 655.35 is displayed when the malfunction signal is received.
ODO OUTPUT [km/h or mph]		Odometer signal value transmitted to other units via CAN communication.
TACHO METER [rpm]	X	Value of the engine speed signal received from ECM via CAN communication. NOTE: 8191.875 is displayed when the malfunction signal is received.
FUEL METER [L]	X	Fuel level indicated on combination meter.

A
B
C
D
E
F
G
H
I
J
K
L
M

MWI

DIAGNOSIS SYSTEM (COMBINATION METER)

< SYSTEM DESCRIPTION >

Display item [Unit]	MAIN SIGNALS	Description
W TEMP METER [°C]	X	Value of engine coolant temperature signal is received from ECM via CAN communication. NOTE: 215 is displayed when the malfunction signal is input.
ABS W/L [On/Off]		Status of ABS warning lamp detected from ABS warning lamp signal is received from ABS actuator and electric unit (control unit) via CAN communication.
VDC/TCS IND [On/Off]		Status of VDC OFF indicator lamp detected from VDC OFF indicator lamp signal is received from ABS actuator and electric unit (control unit) via CAN communication.
SLIP IND [On/Off]		Status of VDC warning lamp detected from VDC warning lamp signal received from ABS actuator and electric unit (control unit) via CAN communication.
BRAKE W/L [On/Off]		Status of brake warning lamp detected from brake warning lamp signal is received from ABS actuator and electric unit (control unit) via CAN communication. NOTE: Displays "Off" if the brake warning lamp is illuminated when the valve check starts, the parking brake switch is turned ON or the brake fluid level switch is turned ON.
DOOR W/L [On/Off]		Status of door open warning detected from door switch signal received from BCM via CAN communication.
HI-BEAM IND [On/Off]		Status of high beam indicator lamp detected from high beam request signal is received from BCM via CAN communication.
TURN IND [On/Off]		Status of turn indicator lamp detected from turn indicator signal is received from BCM via CAN communication.
FR FOG IND [Off]		This item is displayed, but cannot be monitored.
RR FOG IND [Off]		This item is displayed, but cannot be monitored.
LIGHT IND [On/Off]		Status of light indicator lamp detected from position light request signal is received from BCM via CAN communication.
OIL W/L [On/Off]		Status of oil pressure warning lamp detected from oil pressure switch signal is received from BCM via CAN communication.
MIL [On/Off]		Status of malfunction indicator lamp detected from malfunctioning indicator lamp signal is received from ECM via CAN communication.
GLOW IND [Off]		This item is displayed, but cannot be monitored.
CRUISE IND [On/Off]		<ul style="list-style-type: none"> • Status of CRUISE indicator detected from ASCD status signal is received from ECM via CAN communication. (ASCD models) • Status of CRUISE indicator detected from meter display signal is received from ADAS control unit via CAN communication. (ICC models)
SET IND [On/Off]		Status of SET indicator detected from meter display signal is received from ADAS control unit via CAN communication.
CRUISE W/L [On/Off]		Status of CRUISE warning lamp judged from ICC warning lamp signal received from ADAS control unit with CAN communication line.
BA W/L [On/Off]		Status of IBA OFF indicator lamp judged from IBA OFF indicator lamp signal received from ADAS control unit with CAN communication line.
ATC/T-AMT W/L [On/Off]		Status of A/T CHECK warning lamp judged from A/T CHECK indicator lamp signal received from TCM with CAN communication line.
ATF TEMP W/L [Off]		This item is displayed, but cannot be monitored.
4WD W/L [On/Off]		Status of 4WD warning lamp judged from 4WD warning lamp signal received from 4WD control unit with CAN communication line.
FUEL W/L [On/Off]		Low-fuel warning lamp status detected by the identified fuel level.
WASHER W/L [On/Off]		Status of low washer fluid warning judged from washer level switch input to combination meter.



DIAGNOSIS SYSTEM (COMBINATION METER)

< SYSTEM DESCRIPTION >

Display item [Unit]	MAIN SIGNALS	Description	
AIR PRES W/L [On/Off]		Status of low tire pressure warning lamp judged from low tire pressure warning lamp signal received from BCM with CAN communication line.	A
KEY G/Y W/L [On/Off]		Status of KEY warning lamp (Green/Yellow) detected from KEY warning lamp signal is received from BCM via CAN communication.	B
KEY KNOB W/L [Off]		This item is displayed, but cannot be monitored.	C
AFS OFF IND [On/Off]		Status of AFS OFF indicator lamp judged from AFS OFF indicator lamp signal received from AFS control unit with CAN communication line.	
DDS* W/L [Off]		This item is displayed, but cannot be monitored.	D
LANE W/L [On/Off]		Status of lane departure warning lamp judged from lane departure warning lamp signal received from ADAS control unit with CAN communication line.	E
LDP IND [On/Off]		Status of LDP ON indicator lamp judged from LDP ON indicator lamp signal received from ADAS control unit with CAN communication line.	
ATP W/L [On/Off]		Status of ATP warning lamp judged from ATP warning lamp signal received from 4WD control unit with CAN communication line.	F
DCA IND [Off]		This item is displayed, but cannot be monitored.	G
CHECK SUS IND [On/Off]		Status of CK SUSP indicator lamp judged from CK SUSP indicator lamp signal received from E-SUS control unit with CAN communication line.	
LCD [B&P N, B&P I, ID NG, ROTAT, SFT P, INSRT, BATT, NO KY, OUTKY, LK WN]		Displays status of Intelligent Key system warning judged from meter display signal received from BCM with CAN communication line.	H
ACC TARGET [On/Off]		Status of vehicle ahead detection indicator judged from meter display signal received from ADAS control unit with CAN communication line.	I
ACC DISTANCE [Off, Short, Middle, Long]		Status of set distance indicator judged from meter display signal received from ADAS control unit with CAN communication line.	J
ACC OWN VHL [On/Off]		Status of own vehicle indicator judged from meter display signal received from ADAS control unit with CAN communication line.	
ACC SET SPEED [Off, km/h]		Status of set vehicle speed indicator judged from meter display signal received from ADAS control unit with CAN communication line.	K
ACC UNIT [On/Off]		Status of display unit judged from meter display signal received from ADAS control unit with CAN communication line.	L
SHIFT IND [P, R, N, D, M1, M2, M3, M4, M5, M6, M7]		Status of shift position indicator judged from shift position signal and manual mode indicator signal received from TCM with CAN communication line.	M
4WD IND [AUTO, LOCK, 2W, 4Lo, HL1, HL2, MALF]		Status of 4WD indicator judged from 4WD indicator signal received from 4WD control unit with CAN communication line.	MWI
BSW IND [On/Off]		Status of Blind Spot Intervention ON indicator (green) judged from Blind Spot Intervention ON indicator signal received from ADAS control unit with CAN communication line.	
BSW W/L [On/Off]		Status of Blind spot Warning/Blind Spot Intervention warning lamp (yellow) judged from Blind spot Warning/Blind Spot Intervention warning lamp signal received from ADAS control unit with CAN communication line.	O
FUEL CAP W/L [On/Off]		Status of fuel filler cap warning display detected from fuel filler cap warning display signal received from ECM via CAN communication.	P
AT S MODE SW [On/Off]		Status of snow mode switch.	
M RANGE SW [On/Off]		Status of manual mode switch.	

DIAGNOSIS SYSTEM (COMBINATION METER)

< SYSTEM DESCRIPTION >

Display item [Unit]	MAIN SIGNALS	Description
NM RANGE SW [On/Off]		Status of non-manual mode switch.
AT SFT UP SW [On/Off]		Status of manual mode shift up switch.
AT SFT DWN SW [On/Off]		Status of manual mode shift down switch.
PKB SW [On/Off]		Status of parking brake switch.
BUCKLE SW [On/Off]		Status of seat belt buckle switch (driver side).
BRAKE OIL SW [On/Off]		Status of brake fluid level switch.
A/C AMP CONN [Off]		This item is displayed, but cannot be monitored.
ENTER SW [On/Off]		Status of  (ENTER) switch.
SELECT SW [On/Off]		Status of  (SELECT) switch.
DISTANCE [km]		Value of distance to empty calculated by combination meter.
OUTSIDE TEMP [°C or °F]		Ambient temperature value converted from ambient sensor signal received from ambient sensor. NOTE: This may not match with the temperature value indicated on the information display. (Because the information display value is a corrected value from the ambient sensor input value.)
FUEL LOW SIG [On/Off]		Status of fuel level low warning signal to output to AV control unit via CAN communication.
TOW MODE IND [On/Off]		Status of TOW mode indicator lamp judged from TOW mode indicator lamp signal received from TCM with CAN communication line.
BUZZER [On/Off]	X	Buzzer status (in the combination meter) is detected from the buzzer output signal received from each unit via CAN communication and the warning output condition of the combination meter.

*: DDS (hill descent control)

NOTE:

Some items are not available according to vehicle specification.

WARNING HISTORY

- Stores histories when warning/indicator lamp is turned on.
- “Warning History” indicates the “TIME” when the warning/ indicator lamp is turned on.
- The “TIME” above is:
 - 0: The condition that the warning/indicator lamp has been turned on 1 or more times after starting the engine and waiting for 30 seconds.
 - 1 - 39: The number of times the engine was restarted after the 0 condition.
 - NO Warning History: Stores NO (0) turning on history of warning/indicator lamp.

NOTE:

- Warning History is not stored for approximately 30 seconds after the engine starts.
- Brake warning lamp does not store any history when the parking brake is applied or the brake fluid level gets low.

Display Item

Display item	Description
ABS W/L	Lighting history of ABS warning lamp.
VDC/TCS IND	Lighting history of VDC OFF indicator lamp.

DIAGNOSIS SYSTEM (COMBINATION METER)

< SYSTEM DESCRIPTION >

Display item	Description	
SLIP IND	Lighting history of VDC warning lamp.	A
BRAKE W/L	Lighting history of brake warning lamp.	
DOOR W/L	Lighting history of door open warning.	B
OIL W/L	Lighting history of oil pressure warning lamp.	
C-ENG W/L	Lighting history of malfunction indicator lamp.	
CRUISE IND	Lighting history of CRUISE indicator lamp.	C
SET IND	Lighting history of SET indicator lamp.	
CRUISE W/L	Lighting history of CRUISE warning lamp.	D
BA W/L	Lighting history of IBA OFF indicator lamp.	
ATC/T-AMT W/L	Lighting history of A/T CHECK warning lamp.	
4WD W/L	Lighting history of 4WD warning lamp.	E
FUEL W/L	Lighting history of low fuel level warning.	
WASHER W/L	Lighting history of low washer fluid warning.	F
AIR PRES W/L	Lighting history of low tire pressure warning lamp.	
KEY G/Y W/L	Lighting history of KEY warning lamp.	
LANE W/L	Lighting history of lane departure warning lamp.	G

NOTE:

In items displayed on the CONSULT screen, only those listed in the above table are used.

A
B
C
D
E
F
G
H
I
J
K
L
M
O
P

MWI

COMBINATION METER

< ECU DIAGNOSIS INFORMATION >

ECU DIAGNOSIS INFORMATION

COMBINATION METER

Reference Value

INFOID:000000009011926

VALUES ON THE DIAGNOSIS TOOL

NOTE:

The following table includes information (items) inapplicable to this vehicle. For information (items) applicable to this vehicle, refer to CONSULT display items.

Monitor Item	Condition		Value/Status
SPEED METER [km/h]	Ignition switch ON	While driving	Input value of vehicle speed signal (CAN communication signal) NOTE: 655.35 is displayed when the malfunction signal is received
SPEED OUTPUT [km/h]	Ignition switch ON	While driving	Output value of vehicle speed signal (CAN communication signal) NOTE: 655.35 is displayed when the malfunction signal is received
ODO OUTPUT [km/h or mph]	Ignition switch ON	—	Output value of odometer signal (CAN communication signal)
TACHO METER [rpm]	Ignition switch ON	Engine running	Input value of engine speed signal (CAN communication signal) NOTE: 8191.875 is displayed when the malfunction signal is received
FUEL METER [L]	Ignition switch ON	—	Input value of fuel level sensor signal
W TEMP METER [°C]	Ignition switch ON	—	Input value of engine coolant temperature signal (CAN communication signal) NOTE: 215 is displayed when the malfunction signal is input
ABS W/L	Ignition switch ON	ABS warning lamp ON	On
		ABS warning lamp OFF	Off
VDC/TCS IND	Ignition switch ON	VDC OFF indicator lamp ON	On
		VDC OFF indicator lamp OFF	Off
SLIP IND	Ignition switch ON	VDC warning lamp ON	On
		VDC warning lamp OFF	Off
BRAKE W/L	Ignition switch ON	Brake warning lamp ON	On
		Brake warning lamp OFF	Off
DOOR W/L	Ignition switch ON	Door open warning ON	On
		Other than the above	Off
HI-BEAM IND	Ignition switch ON	High-beam indicator lamp ON	On
		High-beam indicator lamp OFF	Off
TURN IND	Ignition switch ON	Turn signal indicator lamp ON	On
		Turn signal indicator lamp OFF	Off
FR FOG IND	Ignition switch ON	NOTE: This item is displayed, but cannot be monitored.	Off

COMBINATION METER

< ECU DIAGNOSIS INFORMATION >

Monitor Item	Condition		Value/Status	
RR FOG IND	Ignition switch ON	NOTE: This item is displayed, but cannot be monitored.	Off	A
LIGHT IND	Ignition switch ON	Position lamp indicator lamp ON	On	B
		Position lamp indicator lamp OFF	Off	
OIL W/L	Ignition switch ON	Oil pressure warning lamp ON	On	C
		Oil pressure warning lamp OFF	Off	
MIL	Ignition switch ON	Malfunction indicator lamp ON	On	D
		Malfunction indicator lamp OFF	Off	
GLOW IND	Ignition switch ON	NOTE: This item is displayed, but cannot be monitored.	Off	E
CRUISE IND	Ignition switch ON	CRUISE indicator ON	On	F
		CRUISE indicator OFF	Off	
SET IND	Ignition switch ON	SET indicator ON	On	G
		SET indicator OFF	Off	
CRUISE W/L	Ignition switch ON	CRUISE warning lamp ON	On	H
		CRUISE warning lamp OFF	Off	
BA W/L	Ignition switch ON	IBA OFF indicator lamp ON	On	I
		IBA OFF indicator lamp OFF	Off	
ATC/T-AMT W/L	Ignition switch ON	A/T check warning lamp ON	On	J
		A/T check warning lamp OFF	Off	
ATF TEMP W/L	Ignition switch ON	NOTE: This item is displayed, but cannot be monitored.	Off	K
4WD W/L	Ignition switch ON	4WD warning lamp ON	On	L
		4WD warning lamp OFF	Off	
FUEL W/L	Ignition switch ON	During low fuel warning indication	On	M
		Other than the above	Off	
WASHER W/L	Ignition switch ON	During low washer fluid warning indication	On	MWI
		Other than the above	Off	
AIR PRES W/L	Ignition switch ON	Low tire pressure warning lamp ON	On	O
		Low tire pressure warning lamp OFF	Off	
KEY G/Y W/L	Ignition switch ON	KEY warning lamp (Green/Yellow) ON	On	P
		KEY warning lamp (Green/Yellow) OFF	Off	
KEY KNOB W/L	Ignition switch ON	NOTE: This item is displayed, but cannot be monitored.	Off	
AFS OFF IND	Ignition switch ON	AFS OFF indicator lamp ON	On	
		AFS OFF indicator lamp OFF	Off	
DDS W/L	Ignition switch ON	NOTE: This item is displayed, but cannot be monitored.	Off	
LANE W/L	Ignition switch ON	Lane departure warning lamp ON	On	
		Lane departure warning lamp OFF	Off	
LDP IND	Ignition switch ON	LDP ON indicator lamp ON	On	
		LDP ON indicator lamp OFF	Off	

COMBINATION METER

< ECU DIAGNOSIS INFORMATION >

Monitor Item	Condition		Value/Status
ATP W/L	Ignition switch ON	ATP warning lamp ON	On
		ATP warning lamp OFF	Off
DCA IND	Ignition switch ON	NOTE: This item is displayed, but cannot be monitored.	Off
CHECK SUS IND	Ignition switch ON	CK SUSP indicator lamp ON	On
		CK SUSP indicator lamp OFF	Off
LCD	Ignition switch ON	During engine start information indication	B&P I
	Ignition switch ACC	During engine start information indication	B&P N
	Ignition switch LOCK	During key ID warning indication	ID NG
	Ignition switch LOCK	During steering lock information indication	ROTAT
	Ignition switch LOCK	During P position warning indication	SFT P
	Ignition switch LOCK	During Intelligent Key insert information indication	INSRT
	Ignition switch LOCK	During Intelligent Key low battery warning indication	BATT
	Ignition switch ON	During take away warning indication	NO KY
	Ignition switch LOCK	During key warning indication	OUTKY
	Ignition switch ON	During ACC warning indication	LK WN
ACC TARGET	Ignition switch ON	During vehicle ahead detection indicator indication	On
		Other than the above	Off
ACC DISTANCE	Ignition switch ON	When following distance set to "LONG"	LONG
		When following distance set to "MIDDLE"	MID
		When following distance set to "SHORT"	SHORT
		Set distance indicator not displayed	Off
ACC OWN VHL	Ignition switch ON	During own vehicle indicator indication	On
		Other than the above	Off
ACC SET SPEED	Ignition switch ON	During set vehicle speed indicator not displayed	Off
		During set vehicle speed indicator displayed	Indicates the set vehicle speed
ACC UNIT	Ignition switch ON	Set vehicle speed indicator unit display ON	On
		Set vehicle speed indicator unit display OFF	Off



COMBINATION METER

< ECU DIAGNOSIS INFORMATION >

Monitor Item	Condition	Value/Status		
SHIFT IND	Ignition switch ON	During the indication of "P" by shift position indicator	P	A
		During the indication of "R" by shift position indicator	R	B
		During the indication of "N" by shift position indicator	N	C
		During the indication of "D" by shift position indicator	D	D
		During the indication of "M1" by shift position indicator	M1	E
		During the indication of "M2" by shift position indicator	M2	F
		During the indication of "M3" by shift position indicator	M3	G
		During the indication of "M4" by shift position indicator	M4	H
		During the indication of "M5" by shift position indicator	M5	I
		During the indication of "M6" by shift position indicator	M6	J
		During the indication of "M7" by shift position indicator	M7	K
4WD IND	Ignition switch ON	4WD shift switch in AUTO position	AUTO	L
		4WD shift switch in 4H position	LOCK	M
		4WD shift switch in 4L position	LOCK/4Lo	MWI
BSW IND	Ignition switch ON	Blind Spot Intervention ON indicator (green) ON	On	O
		Blind Spot Intervention ON indicator (green) OFF	Off	P
BSW W/L	Ignition switch ON	Blind Spot Warning/Blind Spot Intervention warning lamp (yellow) ON	On	
		Blind Spot Warning/Blind Spot Intervention warning lamp (yellow) OFF	Off	
FUEL CAP W/L	Ignition switch ON	Fuel filler cap warning display ON	On	
		Fuel filler cap warning display OFF	Off	
AT S MODE SW	Ignition switch ON	Snow mode switch ON	On	
		Snow mode switch OFF	Off	
M RANGE SW	Ignition switch ON	Selector lever in manual mode position	On	
		Other than the above	Off	
NM RANGE SW	Ignition switch ON	Selector lever in manual mode position	Off	
		Other than the above	On	
AT SFT UP SW	Ignition switch ON	Selector lever in + position	On	
		Other than the above	Off	
AT SFT DWN SW	Ignition switch ON	Selector lever in - position	On	
		Other than the above	Off	
PKB SW	Ignition switch ON	Parking brake switch ON	On	
		Parking brake switch OFF	Off	
BUCKLE SW	Ignition switch ON	Driver seat belt not fastened	On	
		Driver seat belt fastened	Off	

COMBINATION METER

< ECU DIAGNOSIS INFORMATION >

Monitor Item	Condition		Value/Status
BRAKE OIL SW	Ignition switch ON	Brake fluid level switch ON	On
		Brake fluid level switch OFF	Off
A/C AMP CONN	Ignition switch ON	NOTE: This item is displayed, but cannot be monitored.	Off
TOW MODE IND	Ignition switch ON	TOW mode indicator lamp ON	On
		TOW mode indicator lamp OFF	Off
ENTER SW	Ignition switch ON	When  switch (enter switch) is pressed	On
		Other than above	Off
SELECT SW	Ignition switch ON	When  switch (select switch) is pressed	On
		Other than above	Off
DISTANCE [km]	Ignition switch ON	—	Distance to empty calculated by combination meter
OUTSIDE TEMP [°C or °F]	Ignition switch ON	—	Equivalent to ambient temperature NOTE: This may not match the indicated value on the information display.
FUEL LOW SIG	Ignition switch ON	During low fuel warning indication	On
		Other than above	Off
BUZZER	Ignition switch ON	Buzzer ON	On
		Buzzer OFF	Off

NOTE:
Some items are not available according to vehicle specification.

TERMINAL LAYOUT

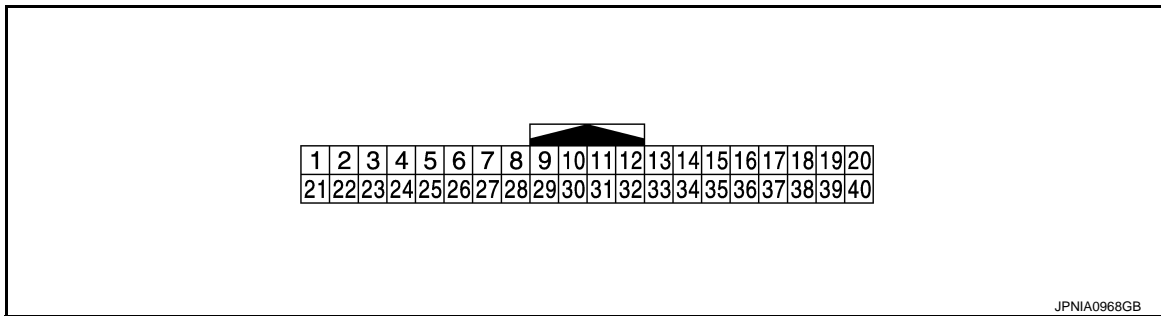





PHYSICAL VALUES

Terminal No. (Wire color)		Description		Condition		Value (Approx.)
+	-	Signal name	Input/ Output			
1 (Y)	Ground	Battery power supply	Input	Ignition switch OFF	—	Battery voltage
2 (GR)	Ground	Ignition signal	Input	Ignition switch ON	—	Battery voltage
3 (B)	Ground	Ground	—	Ignition switch ON	—	0 V

COMBINATION METER

< ECU DIAGNOSIS INFORMATION >

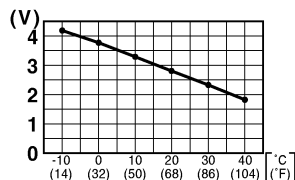
Terminal No. (Wire color)		Description		Condition		Value (Approx.)
+	-	Signal name	Input/ Output			
7 (R)	Ground	TOW mode signal	Input	Ignition switch ON	When TOW mode switch is pressed	0 V
					Other than the above	12 V
8 (P/L)	Ground	Trip reset switch signal	Input	Ignition switch ON	When trip reset switch is pressed	0 V
					Other than the above	5 V
11 (G)	Ground	Enter switch signal	Input	Ignition switch ON	When  switch (enter switch) is pressed	0 V
					Other than the above	5 V
12 (O)	Ground	Select switch signal	Input	Ignition switch ON	When  switch (select switch) is pressed	0 V
					Other than the above	5 V
13 (W/R)	Ground	Illumination control switch signal (+)	Input	Ignition switch ON	When  switch [illumi- nation control switch (+)] is pressed	0 V
					Other than the above	5 V
14 (R)	Ground	Illumination control switch signal (-)	Input	Ignition switch ON	When  switch [illumi- nation control switch (-)] is pressed	0 V
					Other than the above	5 V
15 (R/W)	Ground	Air bag signal	Input	Ignition switch ON	Air bag warning lamp ON	4 V
					Air bag warning lamp OFF	0 V
18 (W/R)	Ground	Ambient sensor signal	Input	—	—	 <p style="text-align: center; font-size: small;">JSNIA0014GB</p>
19 (V/W)	Ground	A/C auto amp. connection recognition signal	Input	—	When A/C auto amp. is connected	5 V
					Other than the above	0 V
20 (B)	Ground	Ambient sensor ground	—	Ignition switch ON	—	0 V
21 (L)	—	CAN-H	—	—	—	—
22 (P)	—	CAN-L	—	—	—	—
23 (B)	Ground	Ground	—	Ignition switch ON	—	0 V
24 (V)	Ground	Fuel level sensor ground	—	Ignition switch ON	—	0 V

A
B
C
D
E
F
G
H
I
J
K
L
M
MWI
O
P

MWI

COMBINATION METER

< ECU DIAGNOSIS INFORMATION >

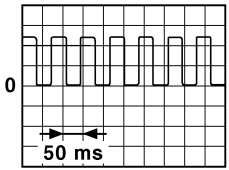
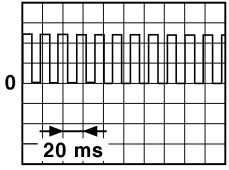
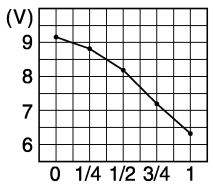
Terminal No. (Wire color)		Description		Condition		Value (Approx.)
+	-	Signal name	Input/ Output			
25 (O/L)	Ground	Alternator signal	Input	Ignition switch ON	Charge warning lamp ON	2 V
					Charge warning lamp OFF	Battery voltage
26 (W)	Ground	Parking brake switch signal	Input	Ignition switch ON	Parking brake applied	0 V
					Parking brake released	12 V
28 (GR/R)	Ground	Security signal	Input	Ignition switch ON	Security indicator lamp ON	0 V
					Security indicator lamp OFF	12 V
29 (BR)	Ground	Washer level switch signal	Input	Ignition switch ON	Washer level switch ON	0 V
					Washer level switch OFF	5 V
30 (SB)	Ground	Vehicle speed signal (2-pulse)	Output	Ignition switch ON	Speedometer operated [When vehicle speed is ap- prox. 40 km/h (25 MPH)]	<p>NOTE: The maximum voltage varies de- pending on the specification (destination unit).</p>  <p style="text-align: right; font-size: small;">JSNIA0015GB</p>
31 (BR/W)	Ground	Vehicle speed signal (8-pulse)	Output	Ignition switch ON	Speedometer operated [When vehicle speed is ap- prox. 40 km/h (25 MPH)]	<p>NOTE: The maximum voltage varies de- pending on the specification (destination unit).</p>  <p style="text-align: right; font-size: small;">JSNIA0012GB</p>
33 (W)	Ground	SNOW mode signal	Input	Ignition switch ON	When SNOW mode switch is pressed	12 V
					Other than the above	0 V
34 (BR/Y)	Ground	Fuel level sensor signal	Input	Ignition switch ON	—	 <p style="text-align: right; font-size: small;">JSNIA3013ZZ</p>
35 (O/B)	Ground	Seat belt buckle switch sig- nal (driver side)	Input	Ignition switch ON	When driver side belts is fastened	12 V
					When driver side belts is unfastened	0 V

COMBINATION METER

< ECU DIAGNOSIS INFORMATION >

Terminal No. (Wire color)		Description		Condition	Value (Approx.)
+	-	Signal name	Input/ Output		
36 (G/Y)	Ground	Passenger seat belt warning signal	Input	Ignition switch ON	12 V
				Ignition switch OFF	0 V
37 (R/Y)	Ground	Non-manual mode signal	Input	Ignition switch ON	12 V
				Ignition switch OFF	0 V
38 (L/W)	Ground	Manual mode shift down signal	Input	Ignition switch ON	0 V
				Ignition switch OFF	12 V
39 (Y/B)	Ground	Manual mode shift up signal	Input	Ignition switch ON	0 V
				Ignition switch OFF	12 V
40 (G/W)	Ground	Manual mode signal	Input	Ignition switch ON	0 V
				Ignition switch OFF	12 V

Fail-Safe

INFOID:000000009011927

FAIL-SAFE

The combination meter activates the fail-safe control if CAN communication with each unit is malfunctioning.

Function	Specifications	
Speedometer	Reset to zero by suspending communication.	
Tachometer		
Engine coolant temperature gauge		
Engine oil pressure gauge		
Illumination control	When suspending communication, changes to nighttime mode.	
Information display	Odo/trip meter	An indicated value is maintained at communications blackout.
	Shift position indicator	The display turns OFF by suspending communication.
	Door open warning	The display turns OFF by suspending communication.
	Fuel filler cap warning	
	Low tire pressure warning	
Buzzer	The buzzer turns OFF by suspending communication.	

COMBINATION METER

< ECU DIAGNOSIS INFORMATION >

	Function	Specifications
Warning lamp/indicator lamp	ABS warning lamp	The lamp turns ON by suspending communication.
	VDC warning lamp	
	Brake warning lamp	
	IBA OFF indicator lamp	
	4WD warning lamp	
	Malfunction indicator lamp	
	VDC OFF indicator lamp	
	CRUISE warning lamp	
	Low tire pressure warning lamp	The lamp blinking caused by suspending communication.
	High beam indicator lamp	The lamp turns OFF by suspending communication.
	Turn signal indicator lamp	
	Position lamp indicator lamp	
	A/T CHECK indicator lamp	
	Key warning lamp	
	ATP warning lamp	
	Lane departure warning lamp	
	LDP ON indicator lamp	
	CRUISE indicator lamp	
	Oil pressure warning lamp	
	SNOW mode indicator lamp	
	TOW mode indicator lamp	
	CK SUSP indicator lamp	
	Blind Spot Intervention ON indicator	
	Blind Spot Warning/Blind Spot Intervention warning lamp	

DTC Index

INFOID:000000009011928

Display contents of CONSULT	Diagnostic item is detected when...	Refer to
CAN COMM CIRCUIT [U1000]	When combination meter is not transmitting or receiving CAN communication signal for 2 seconds or more.	MWI-52. "Diagnosis Procedure"
CONTROL UNIT (CAN) [U1010]	When detecting error during the initial diagnosis of the CAN controller of combination meter.	MWI-53. "Diagnosis Procedure"
VEHICLE SPEED [B2205]	The abnormal vehicle speed signal is input from the ABS actuator and electric unit (control unit) for 2 seconds or more.	MWI-54. "Diagnosis Procedure"
ENGINE SPEED [B2267]	If ECM continuously transmits abnormal engine speed signals for 2 seconds or more.	MWI-55. "Diagnosis Procedure"
WATER TEMP [B2268]	If ECM continuously transmits abnormal engine coolant temperature signals for 60 seconds or more.	MWI-56. "Diagnosis Procedure"

IPDM E/R

< ECU DIAGNOSIS INFORMATION >

IPDM E/R

List of ECU Reference

INFOID:000000009011929

ECU	Reference
IPDM E/R	PCS-15. "Reference Value"
	PCS-20. "Fail-safe"
	PCS-22. "DTC Index"

A
B
C
D
E
F
G
H
I
J
K
L
M
O
P

MWI

METER SYSTEM

< WIRING DIAGRAM >

WIRING DIAGRAM

METER SYSTEM

Wiring Diagram

INFOID:000000009011930

For connector terminal arrangements, harness layouts, and alphabets in a  (option abbreviation; if not described in wiring diagram), refer to [GI-12. "Connector Information"](#).

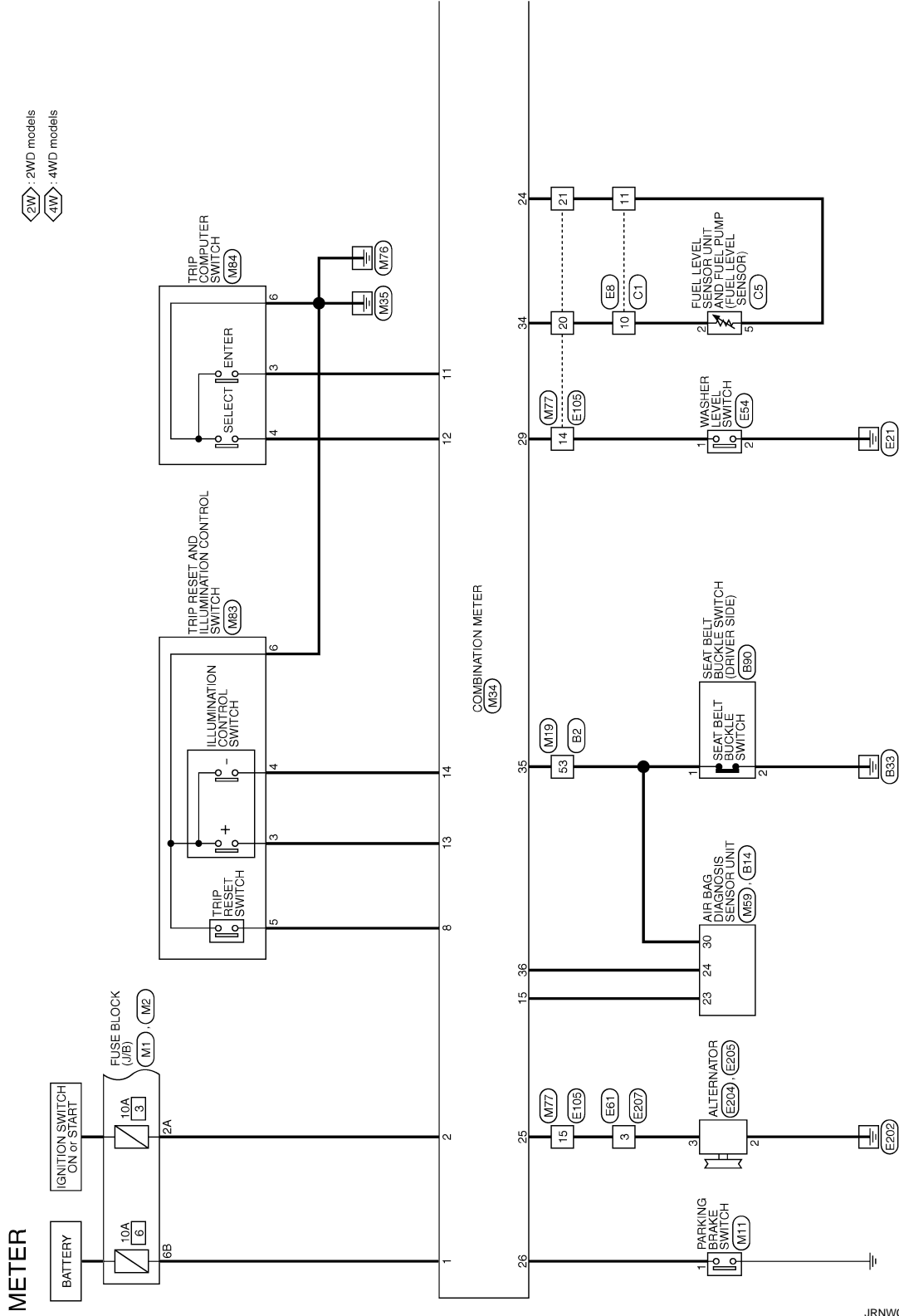

METER SYSTEM

< WIRING DIAGRAM >

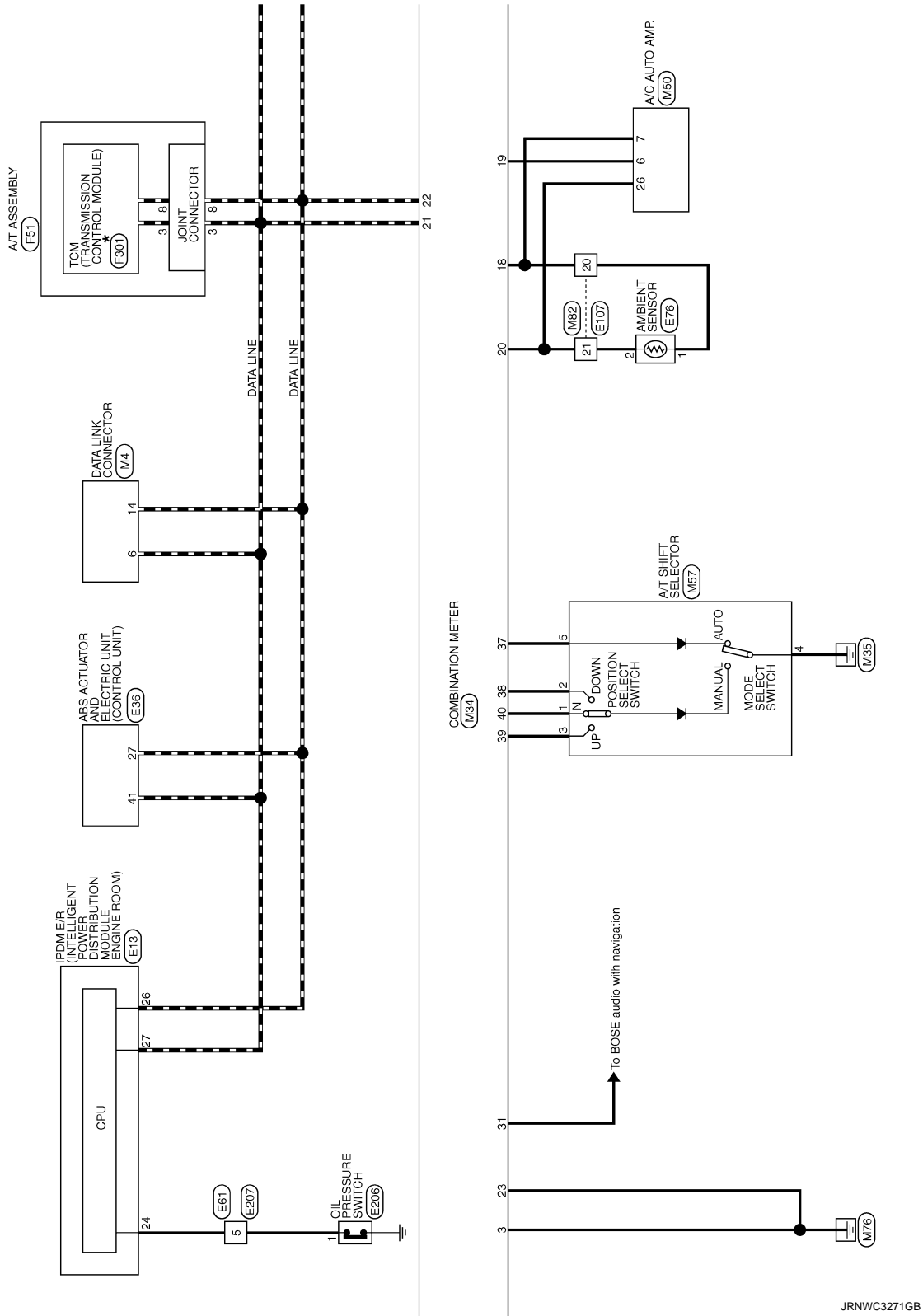

A
B
C
D
E
F
G
H
I
J
K
L
M
MWI
O
P

METER SYSTEM

< WIRING DIAGRAM >

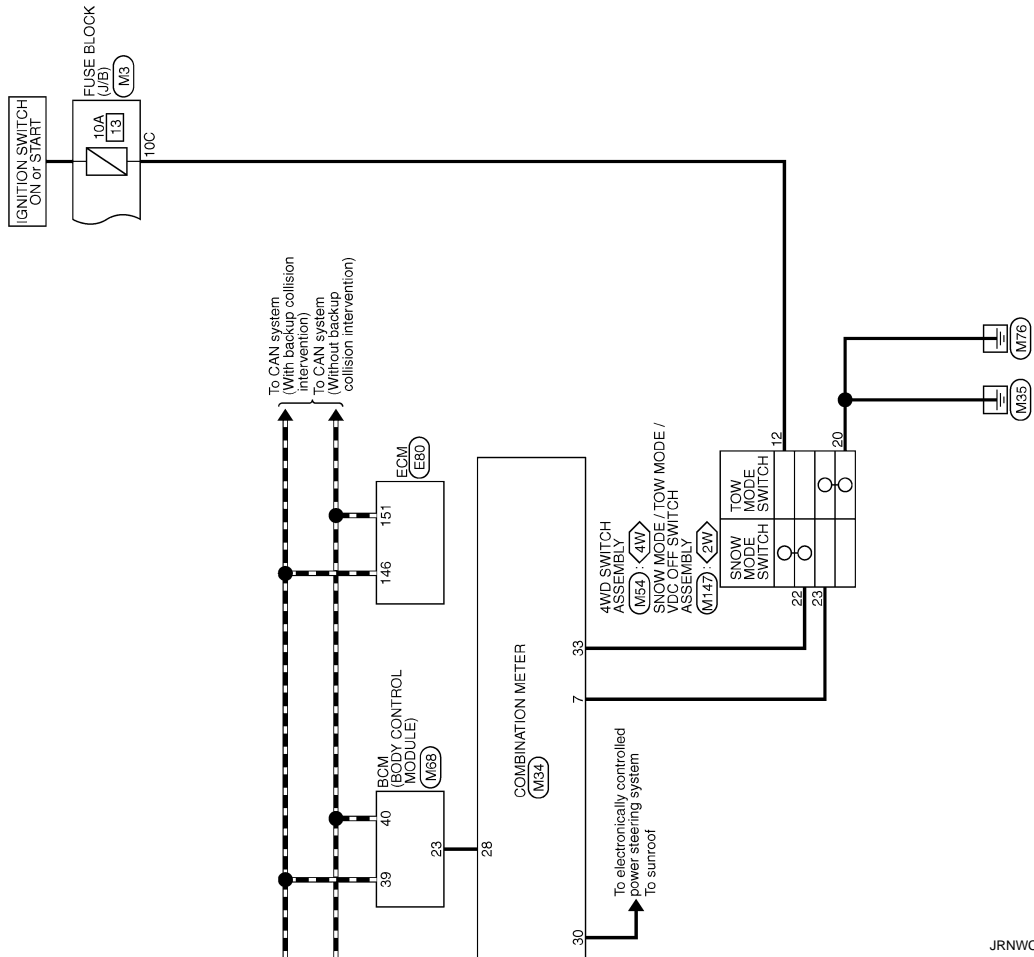

JRNWC3272GB

CLOCK

< WIRING DIAGRAM >

CLOCK

Wiring Diagram

INFOID:000000009011931

For connector terminal arrangements, harness layouts, and alphabets in a  (option abbreviation; if not described in wiring diagram), refer to [GI-12, "Connector Information"](#).

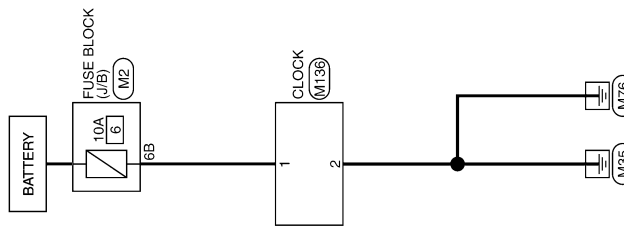

CLOCK

2010/03/12

JCNWM4735GB

A
B
C
D
E
F
G
H
I
J
K
L
M
N
O
P

MWI

DIAGNOSIS AND REPAIR WORKFLOW (METER SYSTEM)

< BASIC INSPECTION >

BASIC INSPECTION

DIAGNOSIS AND REPAIR WORKFLOW (METER SYSTEM)

Work flow

INFOID:000000009011932

OVERALL SEQUENCE

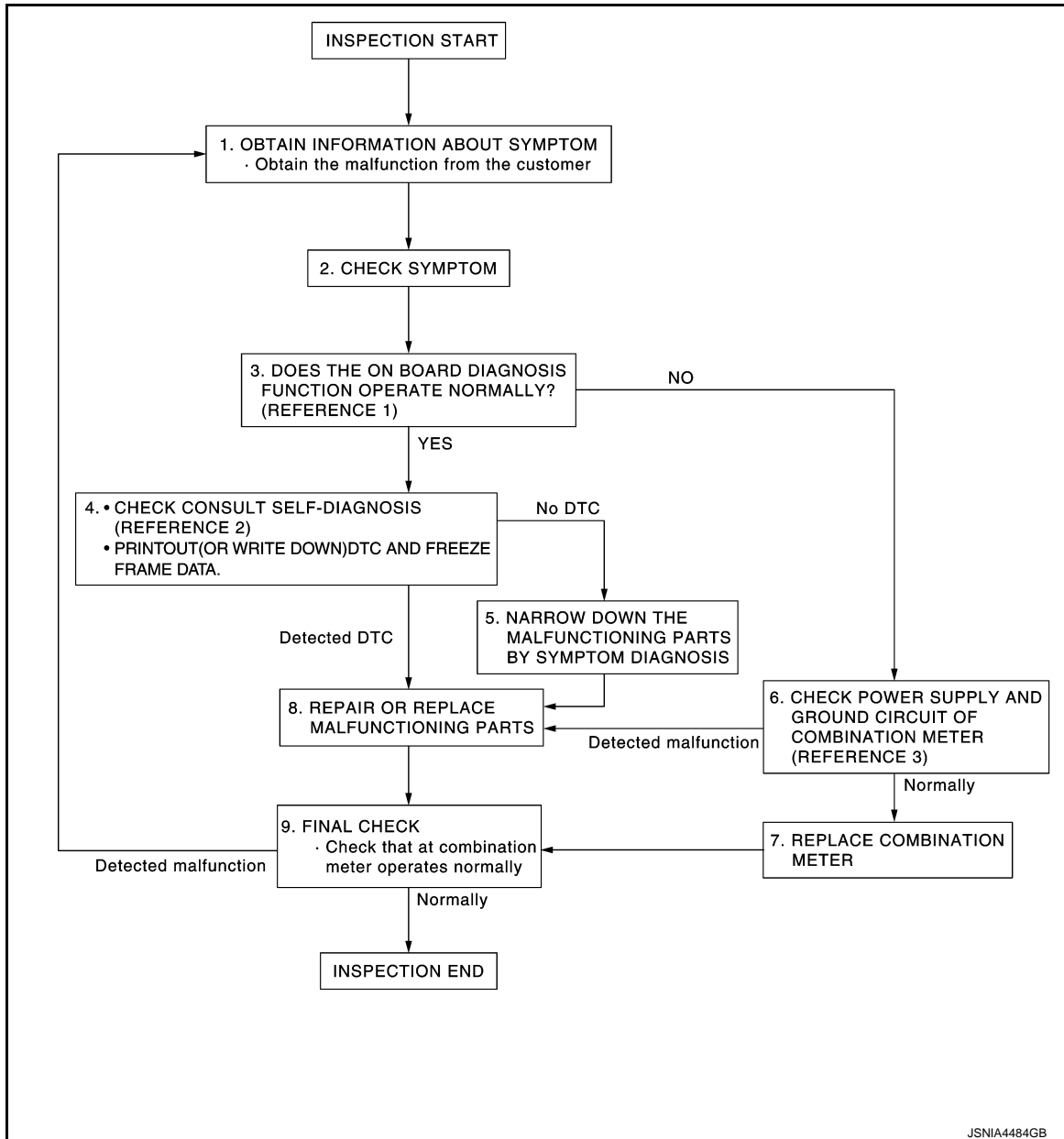

- Reference 1...[MWI-30, "On Board Diagnosis Function"](#).
- Reference 2...[MWI-44, "DTC Index"](#).
- Reference 3...[MWI-57, "COMBINATION METER : Diagnosis Procedure"](#).

DETAILED FLOW

1.OBTAIN INFORMATION ABOUT SYMPTOM

Interview the customer to obtain as much information as possible about the conditions and environment under which the malfunction occurred.

>> GO TO 2.

2.CHECK SYMPTOM

DIAGNOSIS AND REPAIR WORKFLOW (METER SYSTEM)

< BASIC INSPECTION >

- Check the symptom based on the information obtained from the customer.
- Check that any other malfunctions are present.

>> GO TO 3.

3.CHECK ON BOARD DIAGNOSIS OPERATION

Check that the on board diagnosis function operates. Refer to [MWI-30, "On Board Diagnosis Function"](#).

Does the on board diagnosis function operate normally?

YES >> GO TO 4.

NO >> GO TO 6.

4.CHECK CONSULT SELF-DIAGNOSIS RESULTS

1. Connect CONSULT and perform self-diagnosis. Refer to [MWI-44, "DTC Index"](#).

2. When DTC is detected, follow the instructions below:

- Record DTC and Freeze Frame Data.

Are self-diagnosis results normal?

YES >> GO TO 5.

NO >> GO TO 8.

5.NARROW DOWN THE MALFUNCTIONING PARTS BY SYMPTOM DIAGNOSIS

Perform symptom diagnosis and narrow down the malfunctioning parts.

>> GO TO 8.

6.CHECK COMBINATION METER POWER SUPPLY AND GROUND CIRCUITS

Check combination meter power supply and ground circuits. Refer to [MWI-57, "COMBINATION METER : Diagnosis Procedure"](#).

Is inspection result OK?

YES >> GO TO 7.

NO >> GO TO 8.

7.REPLACE COMBINATION METER

Replace combination meter.

>> GO TO 9.

8.REPAIR OR REPLACE MALFUNCTIONING PARTS

Repair or replace the malfunctioning parts.

NOTE:

If DTC is displayed, erase DTC after repair or replace malfunctioning parts.

>> GO TO 9.

9.FINAL CHECK

Check that the combination meter operates normally.

Do they operate normally?

YES >> INSPECTION END

NO >> GO TO 1.

A

B

C

D

E

F

G

H

I

J

K

L

M

MWI

O

P

U1000 CAN COMM CIRCUIT

< DTC/CIRCUIT DIAGNOSIS >

DTC/CIRCUIT DIAGNOSIS

U1000 CAN COMM CIRCUIT

Description

INFOID:000000009011933

CAN (Controller Area Network) is a serial communication system for real time application. It is an on-vehicle multiplex communication system with high data communication speed and excellent error detectability. Many electronic control units are equipped onto vehicles, and each control unit shares information and links with other control units during operation (not independent). In CAN communication, control units are connected with two communication lines (CAN-H line, CAN-L line) allowing a high rate of information transmission with less wiring. Each control unit transmits/receives data but selectively reads required data only.

CAN Communication Signal Chart. Refer to [LAN-32, "CAN COMMUNICATION SYSTEM : CAN Communication Signal Chart"](#).

DTC Logic

INFOID:000000009011934

DTC DETECTION LOGIC

DTC	Display contents of CONSULT	Diagnostic item is detected when...	Probable malfunction location
U1000	CAN COMM CIRCUIT	When combination meter is not transmitting or receiving CAN communication signal for 2 seconds or more.	CAN communication system

Diagnosis Procedure

INFOID:000000009011935

1. PERFORM SELF DIAGNOSTIC

1. Turn ignition switch ON and wait for 2 seconds or more.
2. Check "Self Diagnostic Result" of "METER/M&A".

Is "CAN COMM CIRCUIT" displayed?

- YES >> Refer to [LAN-22, "Trouble Diagnosis Flow Chart"](#).
NO >> Refer to [GI-43, "Intermittent Incident"](#).

U1010 CONTROL UNIT (CAN)

< DTC/CIRCUIT DIAGNOSIS >

U1010 CONTROL UNIT (CAN)

Description

INFOID:000000009011936

Initial diagnosis of combination meter.

DTC Logic

INFOID:000000009011937

DTC DETECTION LOGIC

DTC	Display contents of CONSULT	Diagnostic item is detected when...	Probable malfunction location
U1010	CONTROL UNIT (CAN)	When detecting error during the initial diagnosis of the CAN controller of combination meter.	Combination meter

Diagnosis Procedure

INFOID:000000009011938

1. REPLACE COMBINATION METER

When DTC "U1010" is detected, replace combination meter.

>> INSPECTION END

A
B
C
D
E
F
G
H
I
J
K
L
M
O
P

MWI

B2205 VEHICLE SPEED

< DTC/CIRCUIT DIAGNOSIS >

B2205 VEHICLE SPEED

Description

INFOID:000000009011939

Vehicle speed signal is transmitted from ABS actuator and electric unit (control unit) via CAN communication to combination meter.

DTC Logic

INFOID:000000009011940

DTC DETECTION LOGIC

DTC	Display contents of CONSULT	Diagnostic item is detected when...	Probable malfunction location
B2205	VEHICLE SPEED	An abnormal vehicle speed signal is input from ABS actuator and electric unit (control unit) for 2 seconds or more	<ul style="list-style-type: none">• Wheel sensor• ABS actuator and electric unit (control unit)

Diagnosis Procedure

INFOID:000000009011941

1. PERFORM SELF-DIAGNOSIS OF ABS ACTUATOR AND ELECTRIC UNIT (CONTROL UNIT)

Perform "Self Diagnostic Result" of ABS actuator and electric unit (control unit), and repair or replace malfunctioning parts.

>> Refer to [BRC-50, "DTC Index"](#).

B2267 ENGINE SPEED

< DTC/CIRCUIT DIAGNOSIS >

B2267 ENGINE SPEED

Description

INFOID:000000009011942

The engine speed signal is transmitted from ECM to the combination meter via CAN communication.

DTC Logic

INFOID:000000009011943

DTC DETECTION LOGIC

DTC	Display contents of CONSULT	Diagnostic item is detected when...	Probable malfunction location
B2267	ENGINE SPEED	ECM continuously transmits abnormal engine speed signals for 2 seconds or more	<ul style="list-style-type: none">• Crankshaft position sensor (POS)• ECM

Diagnosis Procedure

INFOID:000000009011944

1. PERFORM SELF-DIAGNOSIS OF ECM

Perform "Self Diagnostic Result" of ECM, and repair or replace malfunctioning parts.

>> Refer to [EC-107, "DTC Index"](#) (VK56VD FOR USA AND CANADA) or [EC-655, "DTC Index"](#) (VK56VD FOR MEXICO).

A
B
C
D
E
F
G
H
I
J
K
L
M
O
P

MWI

B2268 WATER TEMP

< DTC/CIRCUIT DIAGNOSIS >

B2268 WATER TEMP

Description

INFOID:000000009011945

The engine coolant temperature signal is transmitted from ECM to the combination meter via CAN communication.

DTC Logic

INFOID:000000009011946

DTC DETECTION LOGIC

DTC	Display contents of CONSULT	Diagnostic item is detected when...	Probable malfunction location
B2268	WATER TEMP	ECM continuously transmits abnormal engine coolant temperature signals for 60 seconds or more	<ul style="list-style-type: none">• Engine coolant temperature sensor• ECM

Diagnosis Procedure

INFOID:000000009011947

1. PERFORM SELF-DIAGNOSIS OF ECM

Perform "Self Diagnosis Result" of ECM, and repair or replace malfunctioning parts.

>> Refer to [EC-107. "DTC Index"](#) (VK56VD FOR USA AND CANADA) or [EC-655. "DTC Index"](#) (VK56VD FOR MEXICO).

POWER SUPPLY AND GROUND CIRCUIT

< DTC/CIRCUIT DIAGNOSIS >

POWER SUPPLY AND GROUND CIRCUIT COMBINATION METER

COMBINATION METER : Diagnosis Procedure

INFOID:000000009011948

1. CHECK FUSE

Check for blown fuses.

Power source	Fuse No.
Battery	6
Ignition switch ON or START	3

Is the inspection result normal?

YES >> GO TO 2.

NO >> Be sure to eliminate cause of malfunction before installing new fuse.

2. CHECK POWER SUPPLY CIRCUIT

Check voltage between combination meter harness connector and ground.

Terminals		Ignition switch position	Voltage (Approx.)
(+)	(-)		
Combination meter		OFF	Battery voltage
Connector	Terminal		
M34	1		
	2		

Is the inspection result normal?

YES >> GO TO 3.

NO >> Check harness between combination meter and fuse.

3. CHECK GROUND CIRCUIT

1. Turn ignition switch OFF.
2. Disconnect combination meter connector.
3. Check continuity between combination meter harness connector and ground.

Combination meter		Ground	Continuity
Connector	Terminal		
M34	3		Existed
	23		

Is the inspection result normal?

YES >> INSPECTION END

NO >> Repair harness or connector.

A
B
C
D
E
F
G
H
I
J
K
L
M
O
P

MWI

TRIP RESET AND ILLUMINATION CONTROL SWITCH SIGNAL CIRCUIT

< DTC/CIRCUIT DIAGNOSIS >

TRIP RESET AND ILLUMINATION CONTROL SWITCH SIGNAL CIRCUIT

Diagnosis Procedure

INFOID:000000009011949

1. CHECK COMBINATION METER INPUT SIGNAL

1. Turn ignition switch ON.
2. Measure voltage between the following terminals of the combination meter.

(+)		(-)	Condition	Voltage (Approx.)	
Combination meter		Ground			
Connector	Terminals				
M34	8		Ground	When trip reset switch is pressed	0 V
				Other than the above	5 V
	13	When illumination control switch (+) is pressed		0 V	
		Other than the above		5 V	
	14	When illumination control switch (-) is pressed		0 V	
		Other than the above		5 V	

Is the inspection result normal?

YES >> INSPECTION END

NO >> GO TO 2.

2. CHECK TRIP RESET AND ILLUMINATION CONTROL SWITCH SIGNAL CIRCUIT

1. Turn ignition switch OFF.
2. Disconnect combination meter connector and trip reset and illumination control switch connector.
3. Check continuity between combination meter harness connector and trip reset and illumination control switch harness connector.

Terminals				Continuity
Combination meter		Trip reset and illumination control switch		
Connector	Terminal	Connector	Terminal	
M34	8	M83	5	Existed
	13		3	
	14		4	

4. Check continuity between combination meter harness connector and ground.

Combination meter		Ground	Continuity
Connector	Terminal		
M34	8	Ground	Not existed
	13		
	14		

Is the inspection result normal?

YES >> GO TO 3.

NO >> Repair harness or connector.

3. CHECK TRIP RESET AND ILLUMINATION CONTROL SWITCH GROUND CIRCUIT

Check continuity between trip reset and illumination control switch connector and ground.

Trip reset and illumination control switch		Ground	Continuity
Connector	Terminal		
M83	6	Ground	Existed

TRIP RESET AND ILLUMINATION CONTROL SWITCH SIGNAL CIRCUIT

< DTC/CIRCUIT DIAGNOSIS >

Is the inspection result normal?

- YES >> INSPECTION END
- NO >> Repair harness or connector.

Component Inspection

INFOID:000000009011950

1. CHECK TRIP RESET AND ILLUMINATION CONTROL SWITCH

1. Turn ignition switch OFF.
2. Disconnect trip reset and illumination control switch connector.
3. Check trip reset and illumination control switch.

Terminals		Condition	Continuity
Trip reset and illumination control switch			
5	6	When trip reset switch is pressed	Existed
		Other than the above	Not existed
3		When illumination control switch (+) is pressed	Existed
		Other than the above	Not existed
4		When illumination control switch (-) is pressed	Existed
		Other than the above	Not existed

Is the inspection result normal?

- YES >> INSPECTION END
- NO >> Replace trip reset and illumination control switch. Refer to [MWI-79. "Removal and Installation"](#).

A
B
C
D
E
F
G
H
I
J
K
L
M
O
P

MWI

TRIP COMPUTER SWITCH SIGNAL CIRCUIT

< DTC/CIRCUIT DIAGNOSIS >

TRIP COMPUTER SWITCH SIGNAL CIRCUIT

Diagnosis Procedure

INFOID:000000009011951

1. CHECK COMBINATION METER INPUT SIGNAL

1. Turn ignition switch ON.
2. Measure voltage between the following terminals of the combination meter.

(+)		(-)	Condition	Voltage (Approx.)
Combination meter		Ground		
Connector	Terminals			
M34	11		When enter switch is pressed	0 V
			Other than the above	5 V
	12	When select switch is pressed	0 V	
		Other than the above	5 V	

Is the inspection result normal?

YES >> INSPECTION END

NO >> GO TO 2.

2. CHECK TRIP COMPUTER SWITCH SIGNAL CIRCUIT

1. Turn ignition switch OFF.
2. Disconnect combination meter connector and trip computer switch connector.
3. Check continuity between combination meter harness connector and trip computer switch harness connector.

Terminals				Continuity
Combination meter		Trip computer switch		
Connector	Terminal	Connector	Terminal	
M34	11	M84	3	Existed
	12		4	

4. Check continuity between combination meter harness connector and ground.

Combination meter		Ground	Continuity
Connector	Terminal		
M34	11		Not existed
	12		

Is the inspection result normal?

YES >> GO TO 3.

NO >> Repair harness or connector.

3. CHECK TRIP COMPUTER SWITCH GROUND CIRCUIT

Check continuity between trip computer switch connector and ground.

Trip computer switch		Ground	Continuity
Connector	Terminal		
M84	6		Existed

Is the inspection result normal?

YES >> INSPECTION END

NO >> Repair harness or connector.

TRIP COMPUTER SWITCH SIGNAL CIRCUIT

< DTC/CIRCUIT DIAGNOSIS >

Component Inspection

INFOID:000000009011952

1. CHECK TRIP COMPUTER SWITCH

1. Turn ignition switch OFF.
2. Disconnect trip computer switch connector.
3. Check trip computer switch.

Terminals		Condition	Continuity
Trip computer switch			
3	6	When enter switch is pressed	Existed
		Other than the above	Not existed
4		When select switch is pressed	Existed
		Other than the above	Not existed

Is the inspection result normal?

YES >> INSPECTION END

NO >> Replace trip computer switch. Refer to [MWI-80, "Removal and Installation"](#).

A
B
C
D
E
F
G
H
I
J
K
L
M
O
P

MWI

FUEL LEVEL SENSOR SIGNAL CIRCUIT

< DTC/CIRCUIT DIAGNOSIS >

FUEL LEVEL SENSOR SIGNAL CIRCUIT

Component Function Check

INFOID:000000009011953

1. PERFORM COMPONENT FUNCTION CHECK (1)

1. Turn ignition switch OFF.
2. Disconnect fuel level sensor unit and fuel pump connector.
3. Connect variable resistor between harness connector terminals located on the vehicle side of the fuel level sensor unit and fuel pump.

Fuel level sensor unit and fuel pump		
Connector	Terminals	
C5	2	5

4. Set variable resistor according to the resistance value shown in the following table and turn ignition switch ON.

Resistance (Ω *) (Approx.)	Fuel gauge indication position (Approx.)
Less than 94.0	Full
140.0	3/4
186.0	2/4
232.0	1/4
More than 278.0	Empty

*: Reference resistance values used when the combination meter judges the indication position of the fuel gauge.

Is the inspection result normal?

YES >> GO TO 2.

NO >> Refer to [MWI-62, "Diagnosis Procedure"](#).

2. PERFORM COMPONENT FUNCTION CHECK (2)

Check the fuel level sensor unit and fuel pump. Refer to [MWI-63, "Component Inspection"](#).

Is the inspection result normal?

YES >> INSPECTION END

NO >> Replace the fuel level sensor unit and fuel pump. Refer to [FL-5, "Removal and Installation"](#).

Diagnosis Procedure

INFOID:000000009011954

1. CHECK FUEL LEVEL SENSOR CIRCUIT

1. Turn ignition switch OFF.
2. Disconnect combination meter connector and fuel level sensor unit and fuel pump connector.
3. Check continuity between combination meter harness connector terminal and fuel level sensor unit and fuel pump harness connector terminal.

Terminals				Continuity
(+)		(-)		
Combination meter		Fuel level sensor unit and fuel pump		
Connector	Terminal	Connector	Terminal	
M34	34	C5	2	Existed

4. Check continuity between combination meter harness connector terminal and ground.

FUEL LEVEL SENSOR SIGNAL CIRCUIT

< DTC/CIRCUIT DIAGNOSIS >

Terminals				Continuity
(+)		(-)		
Combination meter		Ground		
Connector	Terminal			
M34	34			Not existed

Is the inspection result normal?

YES >> GO TO 2.

NO >> Repair harness or connector.

2.CHECK FUEL LEVEL SENSOR GROUND CIRCUIT

1. Check continuity between fuel level sensor unit and fuel pump harness connector terminal and combination meter harness connector terminal.

Terminals				Continuity
(+)		(-)		
Fuel level sensor unit and fuel pump		Combination meter		
Connector	Terminal	Connector	Terminal	
C5	5	M34	24	Existed

2. Check continuity between fuel level sensor unit and fuel pump harness connector terminal and ground.

Terminals				Continuity
(+)		(-)		
Fuel level sensor unit and fuel pump		Ground		
Connector	Terminal			
C5	5			Not existed

Is the inspection result normal?

YES >> Replace combination meter. Refer to [MWI-78, "Removal and Installation"](#).

NO >> Repair the harnesses or connectors.

Component Inspection

INFOID:000000009011955

1.REMOVE FUEL LEVEL SENSOR UNIT AND FUEL PUMP

Remove the fuel level sensor unit and fuel pump. Refer to [FL-5, "Removal and Installation"](#).

>> GO TO 2.

2.CHECK FUEL LEVEL SENSOR UNIT AND FUEL PUMP

Check the resistance between fuel level sensor unit and fuel pump.

Terminals		Condition	Resistance (Ω) (Approx.)	Height [mm (in)]
Fuel level sensor unit and fuel pump				
2	5	Full* (A)	46.0	280.7 (11.05)
		Empty* (B)	283.0	29.4 (1.157)

*: When float rod is contact with stopper.

Is inspection result OK?

YES >> INSPECTION END

NO >> Replace fuel level sensor unit and fuel pump. Refer to [FL-5, "Removal and Installation"](#).

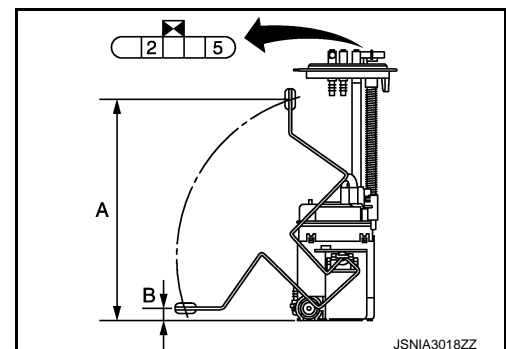

OIL PRESSURE SWITCH SIGNAL CIRCUIT

< DTC/CIRCUIT DIAGNOSIS >

OIL PRESSURE SWITCH SIGNAL CIRCUIT

Component Function Check

INFOID:000000009011956

1. CHECK COMBINATION METER INPUT SIGNAL

Select the "Data Monitor" for the "METER/M&A" and check the "OIL W/L" monitor value.

"OIL W/L"
 Ignition switch ON : On
 Engine running : Off

>> INSPECTION END

Diagnosis Procedure

INFOID:000000009011957

1. CHECK OIL PRESSURE SWITCH CIRCUIT

1. Turn ignition switch OFF.
2. Disconnect IPDM E/R connector and oil pressure switch connector.
3. Check continuity between IPDM E/R harness connector and oil pressure switch harness connector.

Terminals				Continuity
(+)		(-)		
IPDM E/R		Oil pressure switch		
Connector	Terminal	Connector	Terminal	
E13	24	E206	1	Existed

4. Check continuity between IPDM E/R harness connector and ground.

Terminals				Continuity
(+)		(-)		
IPDM E/R		Ground		
Connector	Terminal			
E13	24			Not existed

Is the inspection result normal?

- YES >> INSPECTION END
 NO >> Repair harness or connector.

Component Inspection

INFOID:000000009011958

1. CHECK OIL PRESSURE SWITCH

Check continuity between oil pressure switch and ground.

Condition	Continuity
Engine stopped	Existed
Engine running	Not existed

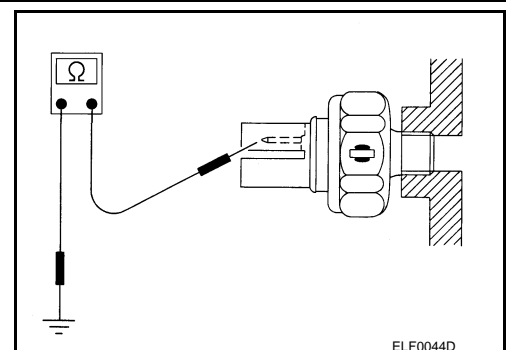

ELF0044D

Is the inspection result normal?

- YES >> INSPECTION END

OIL PRESSURE SWITCH SIGNAL CIRCUIT

< DTC/CIRCUIT DIAGNOSIS >

NO >> Replace oil pressure switch. Refer to [EM-60. "Removal and Installation"](#).

A

B

C

D

E

F

G

H

I

J

K

L

M

MWI

O

P

WASHER LEVEL SWITCH SIGNAL CIRCUIT

< DTC/CIRCUIT DIAGNOSIS >

WASHER LEVEL SWITCH SIGNAL CIRCUIT

Diagnosis Procedure

INFOID:000000009011959

1. CHECK WASHER LEVEL SWITCH SIGNAL CIRCUIT

1. Turn ignition switch OFF.
2. Disconnect combination meter connector and washer level switch connector.
3. Check continuity between combination meter harness connector and washer level switch harness connector.

Terminals				Continuity
Combination meter		Washer level switch		
Connector	Terminal	Connector	Terminal	
M34	29	E54	1	Existed

4. Check continuity between combination meter harness connector and ground.

Terminals			Continuity
Combination meter		Ground	
Connector	Terminal		
M34	29		Not existed

Is the inspection result normal?

- YES >> GO TO 2.
NO >> Repair harness or connector.

2. CHECK WASHER LEVEL SWITCH GROUND CIRCUIT

Check continuity between washer level switch connector and ground.

Terminals			Continuity
Washer level switch		Ground	
Connector	Terminal		
E54	2		Existed

Is the inspection result normal?

- YES >> INSPECTION END
NO >> Repair harness or connector.

Component Inspection

INFOID:000000009011960

1. CHECK WASHER LEVEL SWITCH

1. Turn ignition switch OFF.
2. Disconnect washer level switch connector.
3. Check washer level switch.

Terminals		Condition	Continuity
Washer level switch			
1	2	Washer level switch ON	Existed
		Washer level switch OFF	Not existed

Is the inspection result normal?

- YES >> INSPECTION END
NO >> Replace washer level switch. Refer to [WW-54. "Removal and Installation"](#).

A/C AUTO AMP. CONNECTION RECOGNITION SIGNAL CIRCUIT

< DTC/CIRCUIT DIAGNOSIS >

A/C AUTO AMP. CONNECTION RECOGNITION SIGNAL CIRCUIT

Diagnosis Procedure

INFOID:000000009011961

1. CHECK A/C AUTO AMP. CONNECTION RECOGNITION SIGNAL

1. Turn ignition switch ON.
2. Check voltage between combination meter harness connector and ground.

Terminals		Voltage (Approx.)
(+)	(-)	
Combination meter		Ground
Connector	Terminal	
M34	19	
		5 V

Is the inspection result normal?

- YES >> INSPECTION END
NO >> GO TO 2.

2. CHECK A/C AUTO AMP. CONNECTION RECOGNITION SIGNAL CIRCUIT

1. Turn ignition switch OFF.
2. Disconnect combination meter connector and A/C auto amp. connector.
3. Check continuity between combination meter harness connector and A/C auto amp. harness connector.

Combination meter		A/C auto amp.		Continuity
Connector	Terminal	Connector	Terminal	
M34	19	M50	6	Existed

4. Check continuity between combination meter harness connector and ground.

Combination meter		Ground	Continuity
Connector	Terminal		
M34	19		Not existed

Is the inspection result normal?

- YES >> INSPECTION END
NO >> Repair harness or connector.

A
B
C
D
E
F
G
H
I
J
K
L
M
O
P

MWI

THE FUEL GAUGE INDICATOR DOES NOT OPERATE

< SYMPTOM DIAGNOSIS >

SYMPTOM DIAGNOSIS

THE FUEL GAUGE INDICATOR DOES NOT OPERATE

Description

INFOID:000000009011962

Fuel gauge will not indicate from a certain position.

Diagnosis Procedure

INFOID:000000009011963

1. CONDUCTING THE COMBINATION METER SELF-DIAGNOSIS MODE

Perform the self-diagnosis mode of combination meter, and then check that the fuel gauge operates normally. Refer to [MWI-30, "On Board Diagnosis Function"](#).

Is the inspection result normal?

- YES >> GO TO 2.
- NO >> Replace the combination meter.

2. CHECK FLOAT INTERFERENCE

Check that the float arm interferes with or binds to other components in the fuel tank.

Is the inspection result normal?

- YES >> GO TO 3.
- NO >> Repair or replace malfunctioning part.

3. CHECK FUEL LEVEL SENSOR SIGNAL CIRCUIT

Check the fuel level sensor signal circuit. Refer to [MWI-62, "Component Function Check"](#).

Is the inspection result normal?

- YES >> Check intermittent incident. Refer to [GI-43, "Intermittent Incident"](#).
- NO >> Repair or replace malfunctioning parts.

THE TRIP RESET AND ILLUMINATION CONTROL SWITCH IS INOPERATIVE

< SYMPTOM DIAGNOSIS >

THE TRIP RESET AND ILLUMINATION CONTROL SWITCH IS INOPERATIVE

Description

INFOID:000000009011964

If any of the following malfunctions is found for the trip reset and illumination control switch operation.

- All switches are inoperative
- The specified switch cannot be operated

Diagnosis Procedure

INFOID:000000009011965

1. CHECK TRIP RESET AND ILLUMINATION CONTROL SWITCH SIGNAL CIRCUIT

Check the trip reset and illumination control switch signal circuit. Refer to [MWI-58, "Diagnosis Procedure"](#).

Is the inspection result normal?

YES >> GO TO 2.

NO >> Repair harness or connector.

2. CHECK TRIP RESET AND ILLUMINATION CONTROL SWITCH

Perform a unit check for the trip reset and illumination control switch. Refer to [MWI-59, "Component Inspection"](#).

Is the inspection result normal?

YES >> Replace combination meter. Refer to [MWI-78, "Removal and Installation"](#).

NG >> Replace trip reset and illumination control switch. Refer to [MWI-79, "Removal and Installation"](#).

A
B
C
D
E
F
G
H
I
J
K
L
M
O
P

MWI

THE TRIP COMPUTER SWITCH IS INOPERATIVE

< SYMPTOM DIAGNOSIS >

THE TRIP COMPUTER SWITCH IS INOPERATIVE

Description

INFOID:000000009011966

If any of the following malfunctions is found for the trip computer switch operation.

- All switches are inoperative
- The specified switch cannot be operated

Diagnosis Procedure

INFOID:000000009011967

1. CHECK TRIP COMPUTER SWITCH SIGNAL CIRCUIT

Check the trip computer switch signal circuit. Refer to [MWI-60, "Diagnosis Procedure"](#).

Is the inspection result normal?

YES >> GO TO 2.

NO >> Repair harness or connector.

2. CHECK TRIP COMPUTER SWITCH

Perform a unit check for the trip computer switch. Refer to [MWI-61, "Component Inspection"](#).

Is the inspection result normal?

YES >> Replace combination meter. Refer to [MWI-78, "Removal and Installation"](#).

NG >> Replace trip computer switch. Refer to [MWI-80, "Removal and Installation"](#).

THE OIL PRESSURE WARNING LAMP DOES NOT TURN ON

< SYMPTOM DIAGNOSIS >

THE OIL PRESSURE WARNING LAMP DOES NOT TURN ON

Description

INFOID:000000009011968

The oil pressure warning lamp stays off when the ignition switch is turned ON.

Diagnosis Procedure

INFOID:000000009011969

1.CHECK OIL PRESSURE WARNING LAMP

Perform auto active test. Refer to [PCS-10, "Diagnosis Description"](#).

Is oil pressure warning lamp blinking?

- YES >> GO TO 2.
- NO >> GO TO 4.

2.CHECK OIL PRESSURE SWITCH SIGNAL CIRCUIT

Check the oil pressure switch signal circuit. Refer to [MWI-64, "Diagnosis Procedure"](#).

Is the inspection result normal?

- YES >> GO TO 3.
- NO >> Repair harness or connector.

3.CHECK OIL PRESSURE SWITCH

Perform a unit check for the oil pressure switch. Refer to [MWI-64, "Component Inspection"](#).

Is the inspection result normal?

- YES >> Replace IPDM E/R. Refer to [PCS-30, "Removal and Installation"](#).
- NO >> Replace oil pressure switch. Refer to [EM-60, "Removal and Installation"](#).

4.CHECK COMBINATION METER INPUT SIGNAL

Connect CONSULT and perform an input signal check for the combination meter. Refer to [MWI-64, "Component Function Check"](#).

Is the inspection result normal?

- YES >> Replace combination meter. Refer to [MWI-78, "Removal and Installation"](#).
- NO >> Replace IPDM E/R. Refer to [PCS-30, "Removal and Installation"](#).

A
B
C
D
E
F
G
H
I
J
K
L
M
O
P

MWI

THE OIL PRESSURE WARNING LAMP DOES NOT TURN OFF

< SYMPTOM DIAGNOSIS >

THE OIL PRESSURE WARNING LAMP DOES NOT TURN OFF

Description

INFOID:000000009011970

The oil pressure warning lamp remains illuminated while the engine is running (normal oil pressure).

Diagnosis Procedure

INFOID:000000009011971

1. CHECK OIL PRESSURE WARNING LAMP

Perform auto active test. Refer to [PCS-10, "Diagnosis Description"](#).

Is oil pressure warning lamp blinking?

- YES >> GO TO 2.
- NO >> GO TO 5.

2. CHECK IPDM E/R OUTPUT VOLTAGE

1. Turn ignition switch OFF.
2. Disconnect the oil pressure switch connector.
3. Turn ignition switch ON.
4. Check voltage between the oil pressure switch harness connector terminal and ground.

Terminals		Voltage (Approx.)
(+)	(-)	
Oil pressure switch		Ground
Connector	Terminal	
E206	1	
		12 V

Is the inspection result normal?

- YES >> GO TO 3.
- NO >> GO TO 4.

3. CHECK OIL PRESSURE SWITCH

Perform a unit check for the oil pressure switch. Refer to [MWI-64, "Component Inspection"](#).

Is the inspection result normal?

- YES >> Replace IPDM E/R. Refer to [PCS-30, "Removal and Installation"](#).
- NO >> Replace oil pressure switch. Refer to [EM-60, "Removal and Installation"](#).

4. CHECK OIL PRESSURE SWITCH SIGNAL CIRCUIT

Check the oil pressure switch signal circuit. Refer to [MWI-64, "Diagnosis Procedure"](#).

Is the inspection result normal?

- YES >> GO TO 5.
- NO >> Repair harness or connector.

5. CHECK COMBINATION METER INPUT SIGNAL

Connect CONSULT and perform an input signal check for the combination meter. Refer to [MWI-64, "Component Function Check"](#).

Is the inspection result normal?

- YES >> Replace combination meter. Refer to [MWI-78, "Removal and Installation"](#).
- NO >> Replace IPDM E/R. Refer to [PCS-30, "Removal and Installation"](#).

THE PARKING BRAKE RELEASE WARNING CONTINUES DISPLAYING, OR DOES NOT DISPLAY

< SYMPTOM DIAGNOSIS >

THE PARKING BRAKE RELEASE WARNING CONTINUES DISPLAYING, OR DOES NOT DISPLAY

Description

INFOID:000000009011972

- The parking brake warning is displayed during vehicle travel even though the parking brake is released.
- The parking brake warning is not displayed even though driving the vehicle with the parking brake applied.

Diagnosis Procedure

INFOID:000000009011973

1. CHECK PARKING BRAKE WARNING LAMP OPERATION

1. Start engine.
2. Check the operation of the brake warning lamp when operating the parking brake.

Condition	Warning lamp status
Parking brake applied	ON
Parking brake released	OFF

Is the inspection result normal?

- YES >> Replace combination meter. Refer to [MWI-78, "Removal and Installation"](#).
NO >> GO TO 2.

2. CHECK PARKING BRAKE SWITCH SIGNAL CIRCUIT

1. Turn ignition switch OFF.
2. Check the parking brake switch signal circuit. Refer to [WCS-39, "Diagnosis Procedure"](#).

Is the inspection result normal?

- YES >> GO TO 3.
NO >> Repair harness or connector.

3. CHECK PARKING BRAKE SWITCH UNIT

Perform a unit check for the parking brake switch. Refer to [BRC-123, "Component Inspection"](#).

Is the inspection result normal?

- YES >> Replace combination meter. Refer to [MWI-78, "Removal and Installation"](#).
NO >> Replace parking brake switch. Refer to [PB-5, "Exploded View"](#).

A
B
C
D
E
F
G
H
I
J
K
L
M
O
P

MWI

THE LOW WASHER FLUID WARNING CONTINUES DISPLAYING, OR DOES NOT DISPLAY

< SYMPTOM DIAGNOSIS >

THE LOW WASHER FLUID WARNING CONTINUES DISPLAYING, OR DOES NOT DISPLAY

Description

INFOID:000000009011974

- The warning is still displayed even after washer fluid is added.
- The warning is not displayed even though the washer tank is empty.

Diagnosis Procedure

INFOID:000000009011975

1. CHECK WASHER LEVEL SWITCH SIGNAL CIRCUIT

Check the washer level switch signal circuit. Refer to [MWI-66. "Diagnosis Procedure"](#).

Is the inspection result normal?

- YES >> GO TO 2.
NO >> Repair harness or connector.

2. CHECK WASHER LEVEL SWITCH UNIT

Perform a unit check for the washer level switch. Refer to [MWI-66. "Component Inspection"](#).

Is the inspection result normal?

- YES >> Replace combination meter. Refer to [MWI-78. "Removal and Installation"](#).
NO >> Replace washer level switch. Refer to [WW-54. "Removal and Installation"](#).

THE DOOR OPEN WARNING CONTINUES DISPLAYING, OR DOES NOT DISPLAY

< SYMPTOM DIAGNOSIS >

THE DOOR OPEN WARNING CONTINUES DISPLAYING, OR DOES NOT DISPLAY

Description

INFOID:000000009011976

- The door open warning is displayed even though all of the doors are closed.
- The door open warning is not displayed even though a door is ajar.

Diagnosis Procedure

INFOID:000000009011977

1.CHECK BCM INPUT/OUTPUT SIGNAL

Connect CONSULT and check the BCM input signals. Refer to [DLK-98, "Component Function Check"](#).

Is the inspection result normal?

YES >> GO TO 2.

NO >> GO TO 3.

2.CHECK COMBINATION METER INPUT SIGNAL

Select the "Data Monitor" for the "METER/M&A" and check the "DOOR W/L" monitor value.

"DOOR W/L"

Door open : On

Door closed : Off

Is the inspection result normal?

YES >> Replace combination meter. Refer to [MWI-78, "Removal and Installation"](#).

NO >> Replace BCM. Refer to [BCS-82, "Removal and Installation"](#).

3.CHECK DOOR SWITCH SIGNAL CIRCUIT

Check the door switch signal circuit. Refer to [DLK-98, "Diagnosis Procedure"](#).

Is the inspection result normal?

YES >> GO TO 4.

NO >> Repair harness or connector.

4.CHECK DOOR SWITCH

Perform a unit check for the door switch. Refer to [DLK-99, "Component Inspection"](#).

Is the inspection result normal?

YES >> Replace combination meter. Refer to [MWI-78, "Removal and Installation"](#).

NO >> Replace applicable door switch. Refer to [DLK-237, "Removal and Installation"](#).

A
B
C
D
E
F
G
H
I
J
K
L
M
O
P

MWI

THE AMBIENT TEMPERATURE DISPLAY IS INCORRECT

< SYMPTOM DIAGNOSIS >

THE AMBIENT TEMPERATURE DISPLAY IS INCORRECT

Description

INFOID:000000009011978

- The displayed ambient air temperature is higher than the actual temperature.
- The displayed ambient air temperature is lower than the actual temperature.

Diagnosis Procedure

INFOID:000000009011979

NOTE:

Check that the symptom is not applicable to the normal operating condition before starting diagnosis. Refer to [MWI-77, "INFORMATION DISPLAY : Description"](#).

1.CHECK AMBIENT SENSOR SIGNAL CIRCUIT

Check the ambient sensor signal circuit. Refer to [HAC-73, "Diagnosis Procedure"](#).

Is the inspection result normal?

YES >> GO TO 2.

NO >> Repair harness or connector.

2.CHECK A/C AUTO AMP. CONNECTION RECOGNITION SIGNAL CIRCUIT

Check the A/C auto amp. connection recognition signal circuit. Refer to [MWI-67, "Diagnosis Procedure"](#).

Is the inspection result normal?

YES >> GO TO 3.

NO >> Repair harness or connector.

3.CHECK AMBIENT SENSOR

Perform the part check for the ambient sensor. Refer to [HAC-74, "Component Inspection"](#).

Is the inspection result normal?

YES >> Replace combination meter. Refer to [MWI-78, "Removal and Installation"](#).

NO >> Replace ambient sensor. Refer to [HAC-144, "Removal and Installation"](#).

NORMAL OPERATING CONDITION

< SYMPTOM DIAGNOSIS >

NORMAL OPERATING CONDITION INFORMATION DISPLAY

INFORMATION DISPLAY : Description

INFOID:000000009011980

AMBIENT AIR TEMPERATURE

The displayed ambient air temperature on the information display may differ from the actual temperature because it is a corrected value calculated from the ambient sensor signal by the combination meter. Refer to [MWI-20, "INFORMATION DISPLAY : System Description"](#) for details on the correction process.

DISTANCE TO EMPTY

The calculated distance to empty may differ from the actual distance to empty if the refueling amount is approximately 15 ℓ (4 US gal, 3-1/4 Imp gal) or less. This is because the refuel control (moves the fuel gauge needle quicker than normal judging that the driver is refueling the vehicle) is not performing.

A
B
C
D
E
F
G
H
I
J
K
L
M
O
P

MWI

COMBINATION METER

< REMOVAL AND INSTALLATION >

REMOVAL AND INSTALLATION

COMBINATION METER

Exploded View

INFOID:000000009011981

REMOVAL

Refer to [IP-12. "Exploded View"](#).

DISASSEMBLY

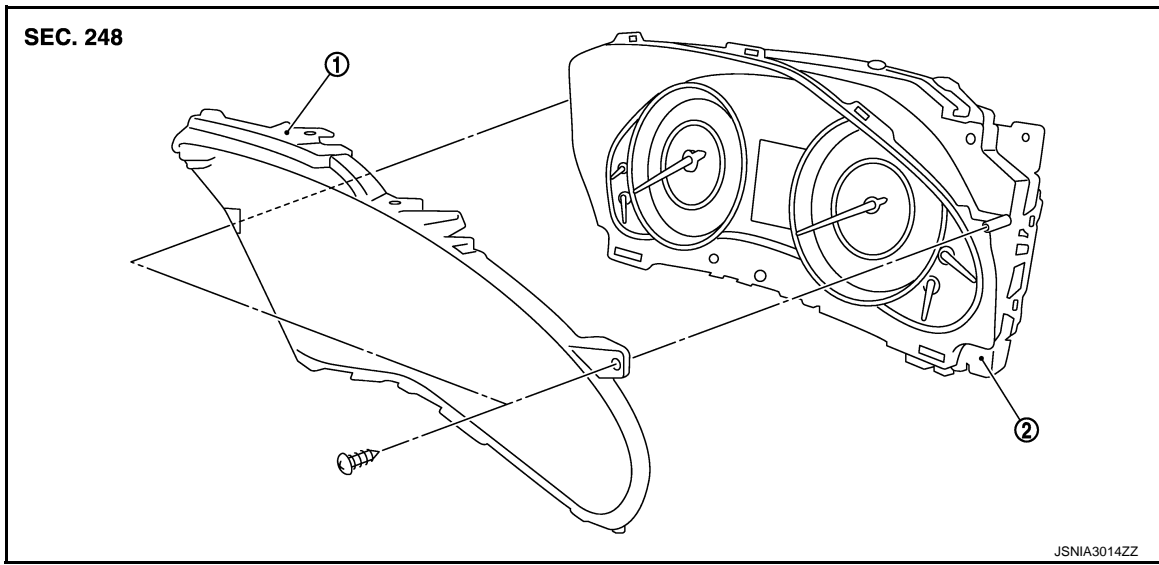

1. Front cover

2. Unified meter control unit

Removal and Installation

INFOID:000000009011982

REMOVAL

1. Remove the cluster lid A. Refer to [IP-13. "Removal and Installation"](#).
2. Remove screws and connector, and then remove combination meter.

INSTALLATION

Install in the reverse order of removal.

Disassembly and Assembly

INFOID:000000009011983

DISASSEMBLY

1. Remove screws.
2. Disengage the tabs to separate front cover.

ASSEMBLY

Assemble in the reverse order of disassembly.

TRIP RESET AND ILLUMINATION CONTROL SWITCH

< REMOVAL AND INSTALLATION >

TRIP RESET AND ILLUMINATION CONTROL SWITCH

Exploded View

INFOID:000000009011984

REMOVAL

Refer to [IP-12. "Exploded View"](#).

Removal and Installation

INFOID:000000009011985

REMOVAL

1. Remove cluster lid A. Refer to [IP-13. "Removal and Installation"](#).
2. Remove clip.
3. Press pawls and remove trip reset and illumination control switch.

INSTALLATION

Install in the reverse order of removal.

A
B
C
D
E
F
G
H
I
J
K
L
M
O
P

MWI

TRIP COMPUTER SWITCH

< REMOVAL AND INSTALLATION >

TRIP COMPUTER SWITCH

Exploded View

INFOID:000000009011986

REMOVAL

Refer to [IP-12. "Exploded View"](#).

Removal and Installation

INFOID:000000009011987

REMOVAL

1. Remove cluster lid A. Refer to [IP-13. "Removal and Installation"](#).
2. Press pawls and remove trip computer switch.

INSTALLATION

Install in the reverse order of removal.

CLOCK

< REMOVAL AND INSTALLATION >

CLOCK

Exploded View

INFOID:000000009011988

REMOVAL

Refer to [IP-12. "Exploded View"](#).

Removal and Installation

INFOID:000000009011989

REMOVAL

1. Remove cluster lid C assembly. Refer to [IP-13. "Removal and Installation"](#).
2. Disengage the tabs to separate clock.

INSTALLATION

Install in the reverse order of removal.

A
B
C
D
E
F
G
H
I
J
K
L
M
O
P

MWI