

RF  
**SECTION**  
**ROOF**

A  
B  
C

**CONTENTS**

<b>PRECAUTION</b> .....	3	<b>ADDITIONAL SERVICE WHEN REPLACING CONTROL UNIT : Description</b> .....	11	F
<b>PRECAUTIONS</b> .....	3	<b>ADDITIONAL SERVICE WHEN REPLACING CONTROL UNIT : Special Repair Requirement</b> .....	11	G
Precaution for Supplemental Restraint System (SRS) "AIR BAG" and "SEAT BELT PRE-TENSIONER" .....	3	<b>DTC/CIRCUIT DIAGNOSIS</b> .....	12	
<b>PREPARATION</b> .....	4	<b>POWER SUPPLY AND GROUND CIRCUIT</b> ....	12	H
<b>PREPARATION</b> .....	4	Diagnosis Procedure .....	12	
Commercial Service Tool .....	4	<b>VEHICLE SPEED SIGNAL CIRCUIT</b> .....	14	I
<b>SYSTEM DESCRIPTION</b> .....	5	Component Function Check .....	14	
<b>COMPONENT PARTS</b> .....	5	Diagnosis Procedure .....	14	
Component Parts Location .....	5	<b>SUNROOF SWITCH</b> .....	15	J
Component Description .....	5	Component Function Check .....	15	
<b>SYSTEM</b> .....	6	Diagnosis Procedure .....	15	
System Diagram .....	6	Component Inspection .....	16	RF
System Description .....	6	<b>SYMPTOM DIAGNOSIS</b> .....	17	
<b>ECU DIAGNOSIS INFORMATION</b> .....	7	<b>SUNROOF DOES NOT OPERATE PROPERLY</b> .....	17	L
<b>BCM (BODY CONTROL MODULE)</b> .....	7	Description .....	17	
List of ECU Reference .....	7	Diagnosis Procedure .....	17	M
<b>SUNROOF SYSTEM</b> .....	8	<b>AUTO OPERATION DOES NOT OPERATE</b> ....	19	
Reference Value .....	8	Description .....	19	
<b>WIRING DIAGRAM</b> .....	9	Diagnosis Procedure .....	19	N
<b>SUNROOF MOTOR ASSEMBLY</b> .....	9	<b>SUNROOF DOES NOT OPERATE ANTI-PINCH FUNCTION</b> .....	20	O
Wiring Diagram .....	9	Diagnosis Procedure .....	20	
<b>BASIC INSPECTION</b> .....	10	<b>RETAINED POWER OPERATION DOES NOT OPERATE PROPERLY</b> .....	21	P
<b>DIAGNOSIS AND REPAIR WORKFLOW</b> .....	10	Diagnosis Procedure .....	21	
WorkFlow .....	10	<b>SQUEAK AND RATTLE TROUBLE DIAGNOSES</b> .....	22	
<b>INSPECTION AND ADJUSTMENT</b> .....	11	Work Flow .....	22	
<b>ADDITIONAL SERVICE WHEN REPLACING CONTROL UNIT</b> .....	11	Inspection Procedure .....	24	

D

E

F

G

H

I

J

RF

L

M

N

O

P

Diagnostic Worksheet .....	26	<b>SUNROOF UNIT ASSEMBLY .....</b>	<b>33</b>
<b>REMOVAL AND INSTALLATION .....</b>	<b>28</b>	Exploded View .....	33
<b>GLASS LID .....</b>	<b>28</b>	Removal and Installation .....	34
Exploded View .....	28	Disassembly and Assembly .....	35
Removal and Installation .....	29	<b>SUNSHADE .....</b>	<b>36</b>
Adjustment .....	29	Exploded View .....	36
<b>SUNROOF MOTOR ASSEMBLY .....</b>	<b>31</b>	Removal and Installation .....	36
Exploded View .....	31	<b>SUNROOF SWITCH .....</b>	<b>37</b>
Removal and Installation .....	32	Removal and Installation .....	37

# PRECAUTIONS

< PRECAUTION >

## PRECAUTION

### PRECAUTIONS

#### Precaution for Supplemental Restraint System (SRS) "AIR BAG" and "SEAT BELT PRE-TENSIONER"

INFOID:000000009010794

The Supplemental Restraint System such as "AIR BAG" and "SEAT BELT PRE-TENSIONER", used along with a front seat belt, helps to reduce the risk or severity of injury to the driver and front passenger for certain types of collision. Information necessary to service the system safely is included in the "SRS AIR BAG" and "SEAT BELT" of this Service Manual.

**WARNING:**

Always observe the following items for preventing accidental activation.

- To avoid rendering the SRS inoperative, which could increase the risk of personal injury or death in the event of a collision that would result in air bag inflation, all maintenance must be performed by an authorized NISSAN/INFINITI dealer.
- Improper maintenance, including incorrect removal and installation of the SRS, can lead to personal injury caused by unintentional activation of the system. For removal of Spiral Cable and Air Bag Module, see "SRS AIR BAG".
- Never use electrical test equipment on any circuit related to the SRS unless instructed to in this Service Manual. SRS wiring harnesses can be identified by yellow and/or orange harnesses or harness connectors.

#### PRECAUTIONS WHEN USING POWER TOOLS (AIR OR ELECTRIC) AND HAMMERS

**WARNING:**

Always observe the following items for preventing accidental activation.

- When working near the Air Bag Diagnosis Sensor Unit or other Air Bag System sensors with the ignition ON or engine running, never use air or electric power tools or strike near the sensor(s) with a hammer. Heavy vibration could activate the sensor(s) and deploy the air bag(s), possibly causing serious injury.
- When using air or electric power tools or hammers, always switch the ignition OFF, disconnect the battery, and wait at least 3 minutes before performing any service.

A  
B  
C  
D  
E  
F  
G  
H  
I  
J  
L  
M  
N  
O  
P

RF

# PREPARATION

< PREPARATION >

## PREPARATION

### PREPARATION

#### Commercial Service Tool

INFOID:000000009010795

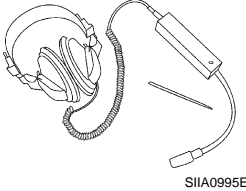
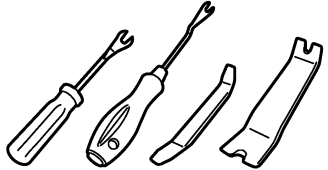
Tool name	Description
<p data-bbox="159 520 267 546">Engine ear</p>  <p data-bbox="771 630 836 646">SIA0995E</p>	<p data-bbox="1006 520 1185 546">Locates the noise</p>
<p data-bbox="159 772 292 798">Remover tool</p>  <p data-bbox="771 882 868 898">JMKIA3050ZZ</p>	<p data-bbox="1006 772 1388 798">Removes clips, pawls, and metal clips</p>

# COMPONENT PARTS

< SYSTEM DESCRIPTION >

## SYSTEM DESCRIPTION

### COMPONENT PARTS

#### Component Parts Location

INFOID:000000009010796

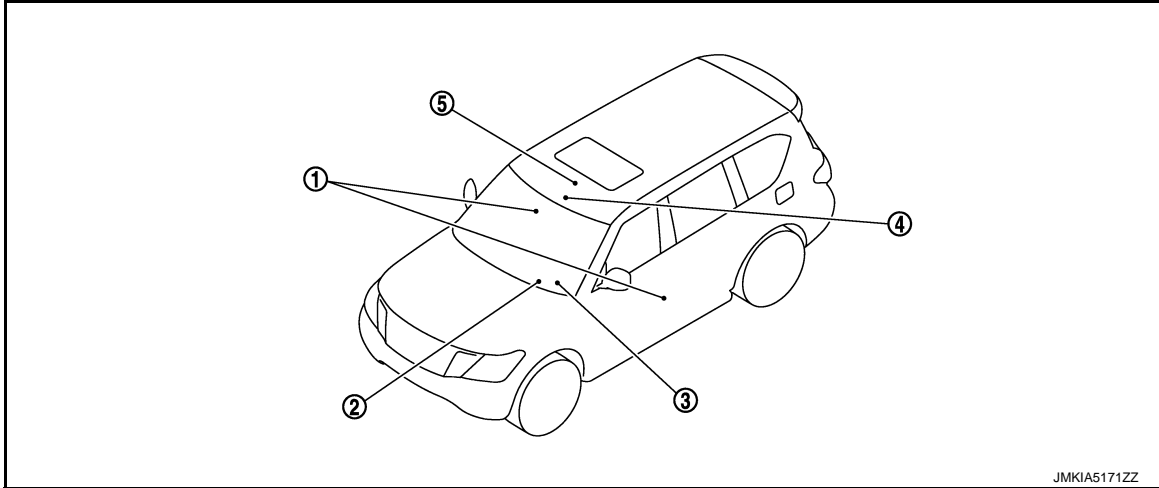

- |                           |  |   |
|---------------------------|--|---|
| 1. Front door switch      | 2. BCM<br>Refer to <a href="#">BCS-4, "BODY CONTROL SYSTEM : Component Parts Location"</a> . | 3. Combination meter<br>Refer to <a href="#">MWI-6, "METER SYSTEM : Component Parts Location"</a> . |
| 4. Sunroof motor assembly | 5. Sunroof switch  |   |

#### Component Description

INFOID:000000009010797

Component	Function
BCM	Supplies the power supply to sunroof motor assembly.
Sunroof switch	Transmits tilt up/down & slides open/close operation signal to sunroof motor assembly.
Sunroof motor assembly	It is sunroof motor and CPU integrated type that enables tilt up/down & slide open/close by sunroof switch operation
Front door switch	Detects door open/close condition and transmits to BCM.
Combination meter	Transmits vehicle speed signal to sunroof motor assembly.

# SYSTEM

< SYSTEM DESCRIPTION >

## SYSTEM

### System Diagram

INFOID:000000009010798

### SUNROOF

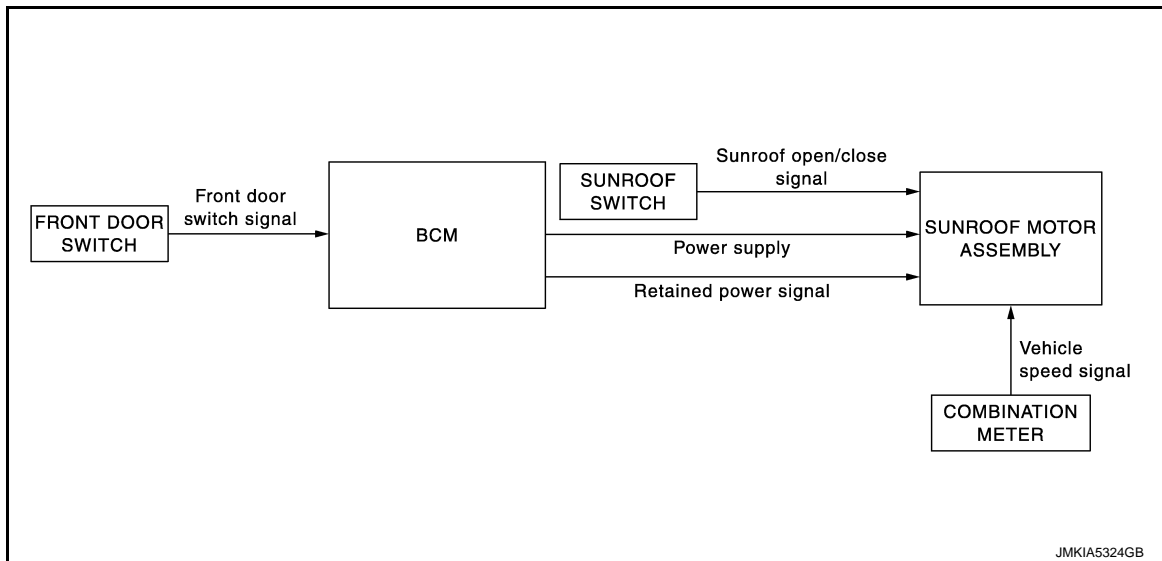

### System Description

INFOID:000000009010799

#### SUNROOF SYSTEM

- Sunroof motor assembly operates with the power supply that is output from BCM while ignition switch is ON or retained power is operating.
- Tilt up/down & slide open/close signals from sunroof switch enables operate sunroof motor to move arbitrarily.
- Sunroof motor assembly receives a vehicle speed signal from combination meter and controls the sunroof motor operation.

#### AUTO OPERATION

Sunroof AUTO feature makes it possible to slide open and slide close or tilt up and tilt down the sunroof without holding the sunroof switch in the slide open/tilt down or slide close/tilt up position.

#### RETAINED POWER OPERATION

- Retained power operation is an additional power supply function that enables sunroof system to operate during 45 seconds even when ignition switch is turned OFF.

Retained power function cancel conditions

- Front door CLOSE (door switch OFF)→OPEN (door switch ON).
- When ignition switch is ON again.
- When timer time passes. (45 seconds)

#### ANTI-PINCH FUNCTION

The CPU of sunroof motor assembly monitors the sunroof motor operation and the sunroof position (fully-closed or other) by the signals from sunroof motor.

When sunroof motor detects an interruption during the following slide close and tilt down operation, sunroof switch controls the motor for open and the sunroof will operate until full up position (when tilt down operate) or 150 mm (5.91 in) or more in an open direction (when slide close operate):

# BCM (BODY CONTROL MODULE)

< ECU DIAGNOSIS INFORMATION >

## ECU DIAGNOSIS INFORMATION

### BCM (BODY CONTROL MODULE)

#### List of ECU Reference

INFOID:000000009010800

ECU	Reference
BCM	<a href="#">BCS-35. "Reference Value"</a>
BCM	<a href="#">BCS-56. "Fail-safe"</a>
BCM	<a href="#">BCS-57. "DTC Index"</a>

A  
B  
C  
D  
E  
F  
G  
H  
I  
J  
RF  
L  
M  
N  
O  
P

RF

# SUNROOF SYSTEM

< ECU DIAGNOSIS INFORMATION >

## SUNROOF SYSTEM

Reference Value

INFOID:000000009010801

TERMINAL LAYOUT

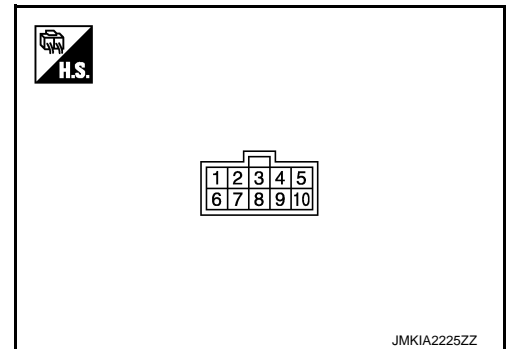

PHYSICAL VALUES

Terminal No. (Wire color)		Description		Condition	Voltage (V) (Approx.)
+	-	Signal name	Input/ Output		
1 (B)	Ground	Ground	—	—	0
3 (Y)	Ground	Retained power signal	Input	Ignition switch ON	12
				Within 45 seconds after ignition switch is turned to OFF	
5 (P)	Ground	Sunroof open signal	Input	Sunroof switch in following position • TILT DOWN • SLIDE OPEN	0
				Ignition switch ON	12
6 (W)	Ground	Sunroof power supply	Input	—	12
8 (SB)	Ground	Vehicle speed signal (2-pulse)	Input	Speedometer operated [When vehicle speed is approx.40km/ h (25MPH)]	
10 (GR)	Ground	Sunroof close signal	Input	Sunroof switch in following position • TILT UP • SLIDE CLOSE	0
				Ignition switch ON	12



# SUNROOF MOTOR ASSEMBLY

< WIRING DIAGRAM >

## WIRING DIAGRAM

### SUNROOF MOTOR ASSEMBLY

#### Wiring Diagram

INFOID:000000009010802

For connector terminal arrangements, harness layouts, and alphabets in a  (option abbreviation; if not described in wiring diagram), refer to [GI-12. "Connector Information"](#).

SUNROOF

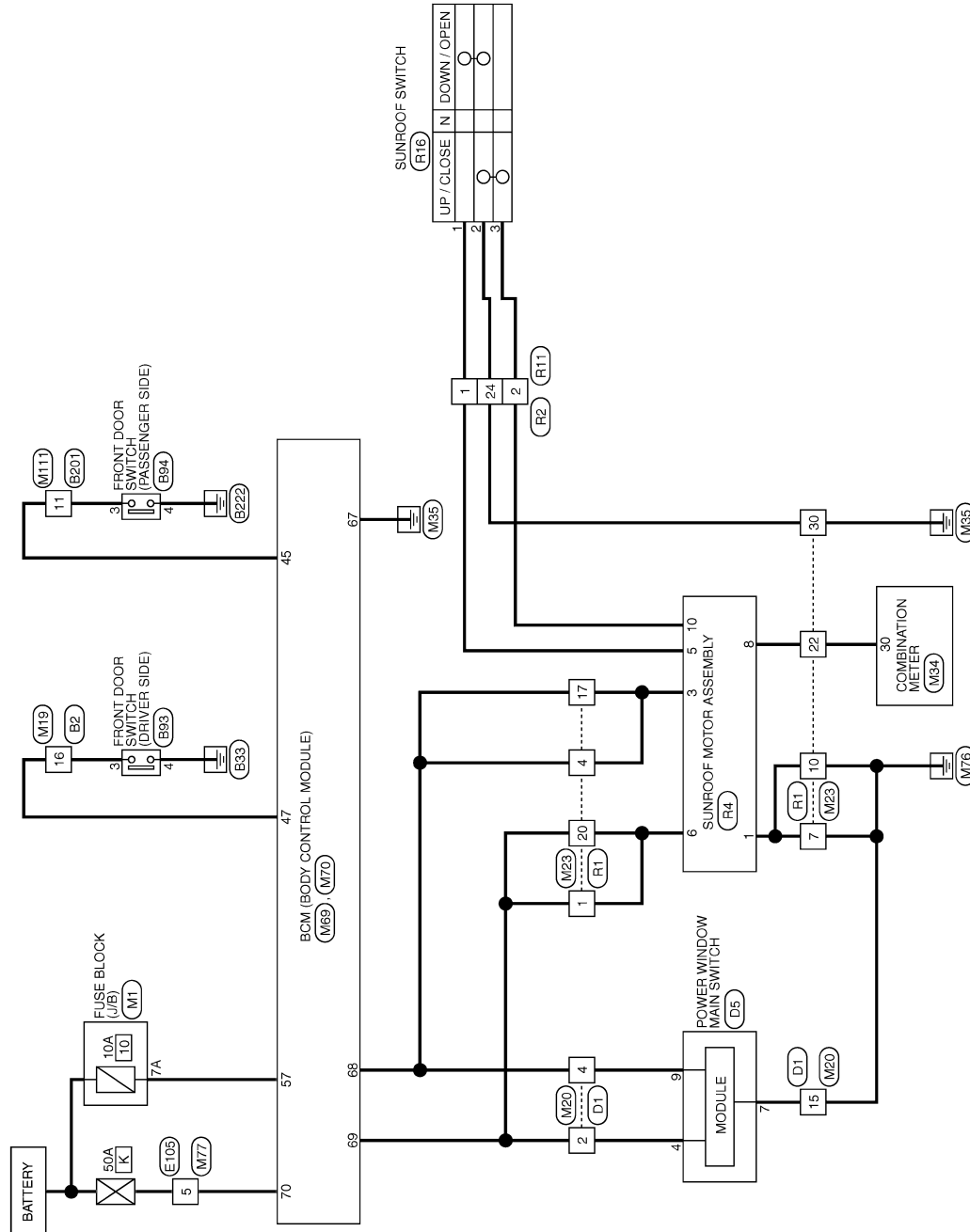

A  
B  
C  
D  
E  
F  
G  
H  
I  
J  
RF  
L  
M  
N  
O  
P

# DIAGNOSIS AND REPAIR WORKFLOW

< BASIC INSPECTION >

## BASIC INSPECTION

### DIAGNOSIS AND REPAIR WORKFLOW

WorkFlow

INFOID:000000009010803

DETAILED FLOW

#### 1.OBTAIN INFORMATION ABOUT SYMPTOM

---

Interview the customer to obtain the malfunction information (conditions and environment when the malfunction occurred) as much as possible when the customer brings the vehicle in.

>> GO TO 2.

#### 2.REPRODUCE THE MALFUNCTION INFORMATION

---

Check the malfunction on the vehicle that the customer describes.  
Inspect the relation of the symptoms and the condition when the symptoms occur.

>> GO TO 3.

#### 3.IDENTIFY THE MALFUNCTIONING SYSTEM WITH "SYMPTOM DIAGNOSIS"

---

Use "Symptom diagnosis" from the symptom inspection result in step 2 and then identify where to start performing the diagnosis based on possible causes and symptoms.

>> GO TO 4.

#### 4.IDENTIFY THE MALFUNCTIONING PARTS WITH "COMPONENT DIAGNOSIS"

---

Perform the diagnosis with "Component diagnosis" of the applicable system.

>> GO TO 5.

#### 5.REPAIR OR REPLACE THE MALFUNCTIONING PARTS

---

Repair or replace the specified malfunctioning parts.

>> GO TO 6.

#### 6.FINAL CHECK

---

Check that malfunctions are not reproduced when obtaining the malfunction information from the customer, referring to the symptom inspection result in step 2.

Are the malfunctions corrected?

YES >> INSPECTION END

NO >> GO TO 3.

# INSPECTION AND ADJUSTMENT

< BASIC INSPECTION >

## INSPECTION AND ADJUSTMENT

### ADDITIONAL SERVICE WHEN REPLACING CONTROL UNIT

#### ADDITIONAL SERVICE WHEN REPLACING CONTROL UNIT : Description

INFOID:000000009010804

#### MEMORY RESET PROCEDURE

1. Please observe the following instructions at confirming the sunroof operation.

**NOTE:**

Do not disconnect the electronic power while the sunroof is operating or within 5 seconds after the sunroof stops (to wipe-out the memory of lid position and operating friction).

2. Initialization of system should be conducted after the following conditions.
  - When the sunroof motor is changed.
  - When the sunroof does not operate normally. (Incomplete initialization conditions)

#### ADDITIONAL SERVICE WHEN REPLACING CONTROL UNIT : Special Repair Requirement

INFOID:000000009010805

#### INITIALIZATION PROCEDURE

If the sunroof does not close or open automatically, use the following procedure to return sunroof operation to normal.

1. Press the tilt up switch and start the tilt up operation.
2. Release the tilt up switch once, press the tilt up switch again, press and hold the switch until lid pops up.
3. The glass lid moves slight toward tilt up direction then stop. (Press and hold the switch during this operation)
4. Release the switch again, and press the tilt up switch within the first 10 seconds. (Press and hold the switch)
5. After 4 seconds, the glass lid will be automatically operated in sequence of tilt down, slide open and slide close.
6. After the glass lid stops, release the switch 0.5 second later. (Press and hold the switch during this operation)
7. If slide switch operates normally, this initialization is done.

#### ANTI-PINCH FUNCTION

1. Full open the sunroof.
2. Place a wooden piece (wooden hammer handle, etc.) at near fully closed position.
3. Close the sunroof completely with auto-slide close.

Check that sunroof lowers for approximately 150 mm (5.91in) or 2 seconds with out pinching a wooden piece and stops.

**CAUTION:**

- Never check with hands and other part of body because they may be pinched. Never get pinched.
- Depending on environment and driving conditions, if a similar impact or load is applied to the sunroof it may lower.
- Check that auto-slide operates before inspection when system initialization is performed.
- Perform initial setting when auto-slide operation or anti-pinch function does not operate normally.

# POWER SUPPLY AND GROUND CIRCUIT

< DTC/CIRCUIT DIAGNOSIS >

## DTC/CIRCUIT DIAGNOSIS

### POWER SUPPLY AND GROUND CIRCUIT

#### Diagnosis Procedure

INFOID:000000009010806

#### SUNROOF MOTOR ASSEMBLY

##### 1.CHECK GROUND CIRCUIT

1. Turn ignition switch OFF.
2. Disconnect sunroof motor assembly harness connector.
3. Check continuity between sunroof motor assembly harness connector and ground.

Sunroof motor assembly		Ground	Continuity
Connector	Terminal		
R4	1		Existed

Is the inspection result normal?

YES >> GO TO 2.

NO >> Repair or replace harness or connector.

##### 2.CHECK POWER SUPPLY CIRCUIT-I

1. Turn ignition switch ON.
2. Check voltage between sunroof motor assembly harness connector and ground.

(+) Sunroof motor assembly		(-)	Voltage (V) (Approx.)
Connector	Terminal		
R4	3	Ground	Battery Voltage
	6		

Is the inspection result normal?

YES >> Check intermittent incident. Refer to [GI-43. "Intermittent Incident"](#).

NO >> GO TO 3.

##### 3.CHECK POWER SUPPLY CIRCUIT-II

1. Turn ignition switch OFF.
2. Disconnect BCM harness connector and power window main switch harness connector.
3. Check continuity between BCM harness connector and sunroof motor assembly harness connector.

BCM		Sunroof motor assembly		Continuity
Connector	Terminal	Connector	Terminal	
M70	68	R4	3	Existed

4. Check continuity between sunroof motor assembly harness connector and ground.

Sunroof motor assembly		Ground	Continuity
Connector	Terminal		
R4	3		Not existed

Is the inspection result normal?

YES >> GO TO 4.

NO >> Repair or replace harness or connector.

##### 4.CHECK POWER SUPPLY CIRCUIT-III

1. Check continuity between BCM harness connector and sunroof motor assembly harness connector.

# POWER SUPPLY AND GROUND CIRCUIT

## < DTC/CIRCUIT DIAGNOSIS >

BCM		Sunroof motor assembly		Continuity
Connector	Terminal	Connector	Terminal	
M70	69	R4	6	Existed

2. Check continuity between sunroof motor assembly harness connector and ground.

Sunroof motor assembly		Ground	Continuity
Connector	Terminal		
R4	6		Not existed

Is the inspection result normal?

- YES >> Check BCM power supply and ground circuit. Refer to [BCS-75, "Diagnosis Procedure"](#).
- NO >> Repair or replace harness or connector.

A  
B  
C  
D  
E  
F  
G  
H  
I  
J  
L  
M  
N  
O  
P

RF

# VEHICLE SPEED SIGNAL CIRCUIT

< DTC/CIRCUIT DIAGNOSIS >

## VEHICLE SPEED SIGNAL CIRCUIT

### Component Function Check

INFOID:000000009010807

#### 1. CHECK SUNROOF MOTOR FUNCTION

Check tilt up/down & slide open/close operations with sunroof switch.

Is the inspection result normal?

YES >> GO TO 2.

NO >> Check sunroof switch. Refer to [RF-15, "Diagnosis Procedure"](#).

#### 2. CHECK SUNROOF MOTOR ASSEMBLY INPUT SIGNAL

1. Start engine.
2. Drive the vehicle at more than 40 km/h (25 MPH).

**CAUTION:**

**Always drive vehicle at a safe speed.**

**NOTE:**

**This procedure may be conducted with the drive wheels lifted in the shop or by driving the vehicle. If a road test is expected to be easier, it is unnecessary to lift the vehicle.**

3. Check tilt up/down & slide open/close operations with sunroof switch.

Is the inspection result normal?

YES >> INSPECTION END

NO >> Refer to [RF-14, "Diagnosis Procedure"](#).

### Diagnosis Procedure

INFOID:000000009010808

#### SUNROOF MOTOR ASSEMBLY

#### 1. CHECK SUNROOF MOTOR ASSEMBLY INPUT SIGNAL

1. Turn ignition switch OFF.
2. Disconnect combination meter harness connector and sunroof motor assembly harness connector.
3. Check continuity between combination meter harness connector and sunroof motor assembly harness connector.

Combination meter		Sunroof motor assembly		Continuity
Connector	Terminal	Connector	Terminal	
M34	30	R4	8	Exists

4. Check continuity between sunroof motor assembly harness connector and ground.

Sunroof motor assembly		Ground	Continuity
Connector	Terminal		
R4	8		Not existed

Is the inspection result normal?

YES >> Check combination meter. Refer to [MWI-54, "Diagnosis Procedure"](#).

NO >> Repair or replace harness or connector.

# SUNROOF SWITCH

< DTC/CIRCUIT DIAGNOSIS >

## SUNROOF SWITCH

### Component Function Check

INFOID:000000009010809

#### 1. CHECK SUNROOF MOTOR FUNCTION

Check tilt up/down & slide open/close operations with sunroof switch.

Is the inspection result normal?

- YES >> INSPECTION END  
NO >> Refer to [RF-15, "Diagnosis Procedure"](#).

### Diagnosis Procedure

INFOID:000000009010810

#### 1. PERFORM INITIALIZATION PROCEDURE

1. Initialization procedure is executed and operation is confirmed. Refer to [RF-11, "ADDITIONAL SERVICE WHEN REPLACING CONTROL UNIT : Special Repair Requirement"](#).
2. Check tilt up/down & slide open/close operations with sunroof switch.

Is the inspection result normal?

- YES >> INSPECTION END  
NO >> GO TO 2.

#### 2. CHECK SUNROOF SWITCH GROUND CIRCUIT

1. Turn ignition switch OFF.
2. Disconnect sunroof switch harness connector.
3. Check continuity between sunroof switch harness connector and ground.

Sunroof switch		Ground	Continuity
Connector	Terminal		
R16	2		Existed

Is the inspection result normal?

- YES >> GO TO 3.  
NO >> Repair or replace harness or connector.

#### 3. CHECK SUNROOF SWITCH INPUT SIGNAL

1. Turn ignition switch ON.
2. Check voltage between sunroof switch harness connector and ground.

(+)		(-)	Voltage (V) (Approx.)
sunroof switch			
Connector	Terminal	Ground	Battery Voltage
R16	1		
	3		

Is the inspection result normal?

- YES >> GO TO 5.  
NO >> GO TO 4.

#### 4. CHECK SUNROOF SWITCH CIRCUIT

1. Turn ignition switch OFF.
2. Disconnect sunroof motor assembly harness connector.
3. Check continuity between sunroof motor assembly harness connector and sunroof switch harness connector.

# SUNROOF SWITCH

## < DTC/CIRCUIT DIAGNOSIS >

Sunroof motor assembly		Sunroof switch		Continuity
Connector	Terminal	Connector	Terminal	
R4	5	R16	1	Existed
	10		3	

4. Check continuity between sunroof motor assembly harness connector and ground.

Sunroof motor assembly		Ground	Continuity
Connector	Terminal		
R4	5		Not existed
	10		

Is the inspection result normal?

YES >> Replace sunroof motor assembly. Refer to [RF-32. "Removal and Installation"](#).

NO >> Repair or replace harness or connector.

## 5.CHECK SUNROOF SWITCH

Check sunroof switch.

Refer to [RF-16. "Component Inspection"](#).

Is the inspection result normal?

YES >> Check intermittent incident. Refer to [GI-43. "Intermittent Incident"](#).

NO >> Replace sunroof switch. Refer to [RF-37. "Removal and Installation"](#).

## Component Inspection

INFOID:000000009010811

## SUNROOF SWITCH

### 1.CHECK SUNROOF SWITCH

1. Turn ignition switch OFF.
2. Disconnect sunroof switch connector.
3. Check continuity sunroof switch terminals.

Terminals		Condition	Continuity
1	2	Sunroof switch is operated TILT DOWN or SLIDE OPEN	Existed
		Other than above	Not existed
3		Sunroof switch is operated TILT UP or SLIDE CLOSE	Existed
		Other than above	Not existed

Is the inspection result normal?

YES >> INSPECTION END

NO >> Replace sunroof switch. Refer to [RF-37. "Removal and Installation"](#).



# SUNROOF DOES NOT OPERATE PROPERLY

< SYMPTOM DIAGNOSIS >

## SYMPTOM DIAGNOSIS

### SUNROOF DOES NOT OPERATE PROPERLY

#### Description

INFOID:000000009010812

Sunroof does not operate normally.

- Glass lid does not slide or tilt.
- Judder occurs during sliding operation of glass lid.
- Sliding or tilting operation of glass lid is slow.

#### Diagnosis Procedure

INFOID:000000009010813

#### 1.CHECK GLASS LID

Check the following items.

- Cracks, damage, or deformation of weather-strip.
- Sticking of weather-strip.
- Loose or missing glass lid mounting blot.
- Misalignment of glass lid.

Refer to [RF-28. "Exploded View"](#).

Is the inspection result normal?

YES >> GO TO 2.

NO >> Repair or replace the malfunctioning parts.

#### 2.CHECK SUNROOF FRAME ASSEMBLY

Check the following items.

- Damage, deformation or trapped foreign material of slide rail.
- Insufficient application of grease to sliding section of slide rail.

Refer to [RF-33. "Exploded View"](#).

Is the inspection result normal?

YES >> GO TO 3.

NO >> Repair or replace the malfunctioning parts.

#### 3.CHECK SUNSHADE

Check sunshade for damage, deformation, of interference with other parts.

Refer to [RF-36. "Exploded View"](#).

Is the inspection result normal?

YES >> GO TO 4.

NO >> Repair or replace the malfunctioning parts.

#### 4.CHECK BCM POWER SUPPLY AND GROUND CIRCUIT

Check BCM power supply and ground circuit.

Refer to [BCS-75. "Diagnosis Procedure"](#).

Is the inspection result normal?

YES >> GO TO 5.

NO >> Repair or replace the malfunctioning parts.

#### 5.CHECK SUNROOF MOTOR ASSEMBLY POWER SUPPLY AND GROUND CIRCUIT

Check sunroof motor assembly power supply and ground circuit.

Refer to [RF-12. "Diagnosis Procedure"](#).

Is the inspection result normal?

YES >> GO TO 6.

NO >> Repair or replace the malfunctioning parts.

#### 6.CHECK SUNROOF SWITCH

Check sunroof switch.

Refer to [RF-15. "Component Function Check"](#).

Is the inspection result normal?

A

B

C

D

E

F

G

H

I

J

RF

L

M

N

O

P

## SUNROOF DOES NOT OPERATE PROPERLY

### < SYMPTOM DIAGNOSIS >

---

YES >> GO TO 7.

NO >> Repair or replace the malfunctioning parts.

### 7. CONFIRM THE OPERATION

---

Confirm the operation again.

#### Is the result normal?

YES >> Check intermittent incident. Refer to [GI-43, "Intermittent Incident"](#).

NO >> GO TO 1.

# AUTO OPERATION DOES NOT OPERATE

< SYMPTOM DIAGNOSIS >

## AUTO OPERATION DOES NOT OPERATE

### Description

INFOID:000000009010814

Auto operation does not operate

- Auto operation of glass lid does not operate.
- Glass lid stops halfway.
- Anti-pinch function operates.

### Diagnosis Procedure

INFOID:000000009010815

#### 1.CHECK GLASS LID

Check the following items.

- Cracks, damage, or deformation of weather-strip.
- Sticking of weather-strip.
- Loose or missing glass lid mounting blot.
- Misalignment of glass lid.

Refer to [RF-28. "Exploded View"](#).

Is the inspection result normal?

YES >> GO TO 2.

NO >> Repair or replace the malfunctioning parts.

#### 2.CHECK SUNROOF FRAME ASSEMBLY

Check the following items.

- Damage, deformation or trapped foreign material of slide rail.
- Insufficient application of grease to sliding section of slide rail.

Refer to [RF-33. "Exploded View"](#).

Is the inspection result normal?

YES >> GO TO 3.

NO >> Repair or replace the malfunctioning parts.

#### 3.PERFORM INITIALIZATION PROCEDURE

Perform initialization procedure.

Refer to [RF-11. "ADDITIONAL SERVICE WHEN REPLACING CONTROL UNIT : Special Repair Requirement"](#).

Is the inspection result normal?

YES >> INSPECTION END

NO >> Replace sunroof motor assembly. Refer to [RF-32. "Removal and Installation"](#).

A  
B  
C  
D  
E  
F  
G  
H  
I  
J  
RF  
L  
M  
N  
O  
P

# SUNROOF DOES NOT OPERATE ANTI-PINCH FUNCTION

< SYMPTOM DIAGNOSIS >

---

## SUNROOF DOES NOT OPERATE ANTI-PINCH FUNCTION

### Diagnosis Procedure

INFOID:000000009010816

#### 1. PERFORM INITIALIZATION PROCEDURE

---

Perform initialization procedure.

Refer to [RF-11, "ADDITIONAL SERVICE WHEN REPLACING CONTROL UNIT : Special Repair Requirement"](#).

Is the inspection result normal?

YES >> Inspection end.

NO >> Check intermittent incident. Refer to [GI-43, "Intermittent Incident"](#).

# RETAINED POWER OPERATION DOES NOT OPERATE PROPERLY

< SYMPTOM DIAGNOSIS >

## RETAINED POWER OPERATION DOES NOT OPERATE PROPERLY

### Diagnosis Procedure

INFOID:000000009010817

#### 1.CHECK DOOR SWITCH

Check door switch.

Refer to [DLK-98, "Component Function Check"](#).

Is the inspection result normal?

YES >> GO TO 2.

NO >> Repair or replace the malfunctioning parts.

#### 2.CHECK POWER WINDOW MAIN SWITCH

Check power window main switch system.

Refer to [PWC-28, "POWER WINDOW MAIN SWITCH : Diagnosis Procedure"](#).

Is the inspection result normal?

YES >> GO TO 3.

NO >> Repair or replace the malfunctioning parts.

#### 3.CHECK BCM POWER SUPPLY AND GROUND

Check BCM power supply and ground circuit.

Refer to [BCS-75, "Diagnosis Procedure"](#).

Is the inspection result normal?

YES >> GO TO 4.

NO >> Repair or replace the malfunctioning parts.

#### 4.CHECK SUNROOF MOTOR ASSEMBLY POWER SUPPLY AND GROUND

Check sunroof motor assembly power supply and ground circuit.

Refer to [RF-12, "Diagnosis Procedure"](#).

Is the inspection result normal?

YES >> GO TO 5.

NO >> Repair or replace the malfunctioning parts.

#### 5.CHECK SUNROOF SWITCH

Check sunroof switch circuit.

Refer to [RF-15, "Component Function Check"](#).

Is the inspection result normal?

YES >> GO TO 6.

NO >> Repair or replace the malfunctioning parts.

#### 6.CONFIRM THE OPERATION

Confirm the operation again.

Is the result normal?

YES >> Check intermittent incident. Refer to [GI-43, "Intermittent Incident"](#).

NO >> GO TO 1.

A  
B  
C  
D  
E  
F  
G  
H  
I  
J  
RF  
L  
M  
N  
O  
P

# SQUEAK AND RATTLE TROUBLE DIAGNOSES

< SYMPTOM DIAGNOSIS >

## SQUEAK AND RATTLE TROUBLE DIAGNOSES

### Work Flow

INFOID:000000009010818

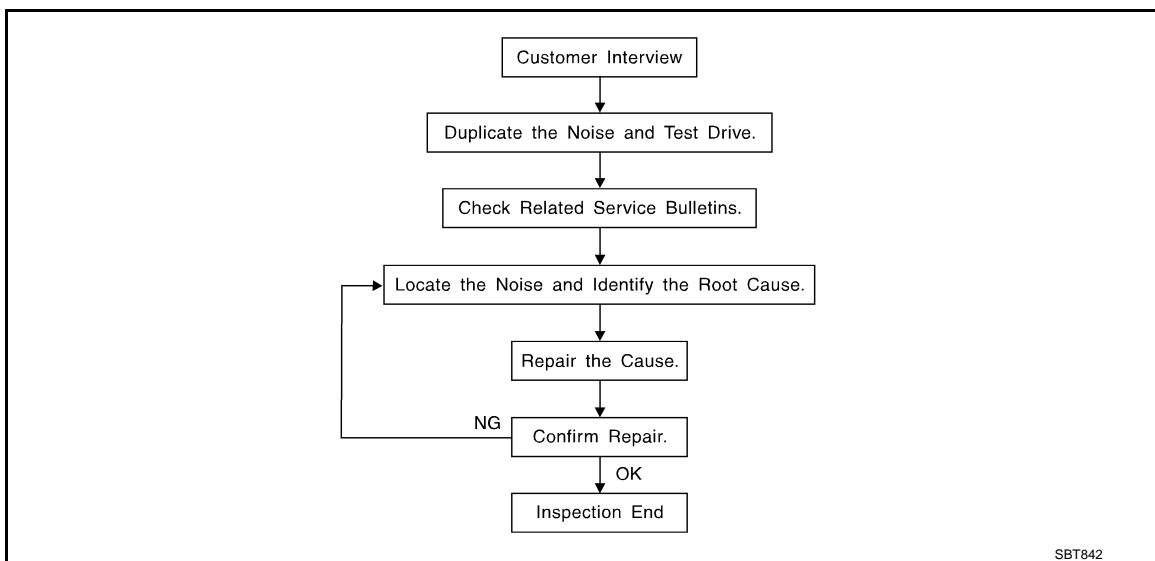

### CUSTOMER INTERVIEW

Interview the customer if possible, to determine the conditions that exist when the noise occurs. Use the Diagnostic Worksheet during the interview to document the facts and conditions when the noise occurs and any customer comments. Refer to [RF-26, "Diagnostic Worksheet"](#). This information is necessary to duplicate the conditions that exist when the noise occurs.

- The customer may not be able to provide a detailed description or the location of the noise. Attempt to obtain all the facts and conditions that exist when the noise occurs (or does not occur).
- If there is more than one noise in the vehicle, perform a diagnosis and repair the noise that the customer is concerned about. This can be accomplished by performing a test drive with the customer.
- After identifying the type of noise, isolate the noise in terms of its characteristics. The noise characteristics are provided so that the customer, service adviser, and technician use the same language when describing the noise.
- Squeak – (Like tennis shoes on a clean floor)  
Squeak characteristics include the light contact / fast movement / brought on by road conditions / hard surfaces = high-pitched noise / softer surfaces = low-pitched noises / edge to surface = chirping
- Creak – (Like walking on an old wooden floor)  
Creak characteristics include firm contact / slow movement/twisting with a rotational movement / pitch dependent on materials / often brought on by activity.
- Rattle – (Like shaking a baby rattle)  
Rattle characteristics include fast repeated contact / vibration or similar movement / loose parts/missing clip or fastener / incorrect clearance.
- Knock – (Like a knock on a door)  
Knock characteristics include hollow sounds / sometimes repeating / often brought on by driver action.
- Tick – (Like a clock second hand)  
Tick characteristics include gentle contacting of light materials / loose components / can be caused by driver action or road conditions.
- Thump – (Heavy, muffled knock noise)  
Thump characteristics include softer knock / dull sounds often brought on by activity.
- Buzz – (Like a bumblebee)  
Buzz characteristics include high frequency rattle / firm contact.
- Often the degree of acceptable noise level varies depending upon the person. A noise that a technician may judge as acceptable may be very irritating to a customer.
- Weather conditions, especially humidity and temperature, may have a great effect on noise level.

### DUPLICATE THE NOISE AND TEST DRIVE

If possible, drive the vehicle with the customer until the noise is duplicated. Note any additional information on the Diagnostic Worksheet regarding the conditions or location of the noise. This information can be used to duplicate the same conditions when the repair is reconfirmed.

# SQUEAK AND RATTLE TROUBLE DIAGNOSES

## < SYMPTOM DIAGNOSIS >

If the noise can be duplicated easily during the test drive, to help identify the source of the noise, try to duplicate the noise with the vehicle stopped by doing one or all of the following items:

- 1) Close a door.
  - 2) Tap or push/pull around the area where the noise appears to be coming from.
  - 3) Rev the engine.
  - 4) Use a floor jack to recreate vehicle "twist".
  - 5) At idle, apply engine load (electrical load, half-clutch on M/T models, drive position on A/T models).
  - 6) Raise the vehicle on a hoist and hit a tire with a rubber hammer.
- Drive the vehicle and attempt to duplicate the conditions the customer states exist when the noise occurs.
  - If it is difficult to duplicate the noise, drive the vehicle slowly on an undulating or rough road to stress the vehicle body.

## CHECK RELATED SERVICE BULLETINS

After verifying the customer concern or symptom, check ASIST for Technical Service Bulletins (TSBs) related to the concern or symptom.

If a TSB relates to the symptom, follow the procedure to repair the noise.

## LOCATE THE NOISE AND IDENTIFY THE ROOT CAUSE

1. Narrow down the noise to a general area. To help pinpoint the source of the noise, use a listening tool (Chassis ear: J-39570, engine ear, and mechanics stethoscope).
2. Narrow down the noise to a more specific area and identify the cause of the noise by:
  - Removing the component(s) in the area that is / are suspected to be the cause of the noise. Do not use too much force when removing clips and fasteners, otherwise clips and fasteners can be broken or lost during the repair, resulting in the creation of new noise.
  - Tapping or pushing/pulling the component(s) that is / are suspected to be the cause of the noise. Do not tap or push/pull the component(s) with excessive force, otherwise the noise is eliminated only temporarily.
  - Feeling for a vibration by hand by touching the component(s) that is / are suspected to be the cause of the noise.
  - Placing a piece of paper between components that are suspected to be the cause of the noise.
  - Looking for loose components and contact marks.  
Refer to [RF-24. "Inspection Procedure"](#).

## REPAIR THE CAUSE

- If the cause is a loose component, tighten the component securely.
- If the cause is insufficient clearance between components:
  - Separate components by repositioning or loosening and retightening the components, if possible.
  - Insulate components with a suitable insulator such as urethane pads, foam blocks, felt cloth tape, or urethane tape. A NISSAN Squeak and Rattle Kit (J-43980) is available through the authorized NISSAN Parts Department.

### **CAUTION:**

**Never use excessive force as many components are constructed of plastic and may be damaged.**

### **NOTE:**

Always check with the Parts Department for the latest parts information.

The following materials are contained in the NISSAN Squeak and Rattle Kit (J-43980). Each item can be ordered separately as needed.

URETHANE PADS [1.5 mm (0.059 in) thick]

Insulates connectors, harness, etc.

- 76268-9E005: 100 × 135 mm (3.937 × 5.315 in)
- 76884-71L01: 60 × 85 mm (2.362 × 3.346 in)
- 76884-71L02: 15 × 25 mm (0.591 × 0.984 in)

INSULATOR (Foam blocks)

Insulates components from contact. Can be used to fill space behind a panel.

- 73982-9E000: 45 mm (1.772 in) thick, 50 × 50 mm (1.969 × 1.969 in)
- 73982-50Y00: 10 mm (0.394 in) thick, 50 × 50 mm (1.969 × 1.969 in)

INSULATOR (Light foam block)

80845-71L00: 30 mm (1.181 in) thick, 30 × 50 mm (1.181 × 1.969 in)

FELT CLOTHTAPE

Used to insulate where movement does not occur. Ideal for instrument panel applications.

- 68370-4B000: 15 × 25 mm (0.591 × 0.984 in) pad
- 68239-13E00: 5 mm (0.197 in) wide tape roll

# SQUEAK AND RATTLE TROUBLE DIAGNOSES

## < SYMPTOM DIAGNOSIS >

---

The following materials, not found in the kit, can also be used to repair squeaks and rattles.

### UHMW (TEFLON) TAPE

Insulates where slight movement is present. Ideal for instrument panel applications.

### SILICONE GREASE

Used in place of UHMW tape that is visible or does not fit. Only lasts a few months.

### SILICONE SPRAY

Used when grease cannot be applied.

### DUCT TAPE

Used to eliminate movement.

## CONFIRM THE REPAIR

After repair is complete, test drive the vehicle to confirm that the cause of noise is repaired by test driving the vehicle. Operate the vehicle under the same conditions as when the noise originally occurred. Refer to the notes on the Diagnostic Worksheet.

## Inspection Procedure

INFOID:000000009010819

Refer to Table of Contents for specific component removal and installation information.

## INSTRUMENT PANEL

Most incidents are caused by contact and movement between:

1. The cluster lid A and instrument panel
2. Acrylic lens and combination meter housing
3. Instrument panel to front pillar garnish
4. Instrument panel to windshield
5. Instrument panel mounting pins
6. Wiring harnesses behind the combination meter
7. A/C defroster duct and duct joint

These incidents can usually be located by tapping or moving the components to duplicate the noise or by pressing on the components while driving to stop the noise. Most of these incidents can be repaired by applying felt cloth tape or silicon spray (in hard to reach areas). Urethane pads can be used to insulate wiring harness.

### **CAUTION:**

**Never use silicone spray to isolate a squeak or rattle. If the area is saturated with silicone, the recheck of repair becomes impossible.**

## CENTER CONSOLE

Components to check include:

1. Shifter assembly cover to finisher
2. A/C control unit and cluster lid C
3. Wiring harnesses behind audio and A/C control unit

The instrument panel repair and isolation procedures also apply to the center console.

## DOORS

Check the following items:

1. Finisher and inner panel making a slapping noise
2. Inside handle escutcheon connection to door finisher
3. Wiring harnesses tapping
4. Door striker out of alignment causing a popping noise on starts and stops

Tapping, moving the components, or pressing on them while driving to duplicate the conditions can isolate many of these incidents. The areas can usually be insulated with felt cloth tape or insulator foam blocks from the NISSAN Squeak and Rattle Kit (J-43980) to repair the noise.

## TRUNK

Trunk noises are often caused by a loose jack or loose items put into the trunk by the customer.

In addition check for the following items:

1. Trunk lid dumpers out of adjustment
2. Trunk lid striker out of adjustment



# SQUEAK AND RATTLE TROUBLE DIAGNOSES

## < SYMPTOM DIAGNOSIS >

---

3. Trunk lid torsion bars knocking together
4. A loose license plate or bracket

Most of these incidents can be repaired by adjusting, securing, or insulating the item(s) or component(s) causing the noise.

## SUNROOF/HEADLINING

Noises in the sunroof / headlining area can often be traced to one of the following items:

1. Sunroof lid, rail, linkage, or seals making a rattle or light knocking noise
2. Sunvisor shaft shaking in the holder
3. Front or rear windshield touching headlining and squeaking

Again, pressing on the components to stop the noise while duplicating the conditions can isolate most of these incidents. Repairs usually consist of insulating with felt cloth tape.

## SEATS

When isolating seat noise it is important to note the position the seat is in and the load placed on the seat when the noise occurs. These conditions should be duplicated when verifying and isolating the cause of the noise.

Causes of seat noise include:

1. Headrest rods and holder
2. A squeak between the seat pad cushion and frame
3. The rear seatback lock and bracket

These noises can be isolated by moving or pressing on the suspected components while duplicating the conditions under which the noise occurs. Most of these incidents can be repaired by repositioning the component or applying urethane tape to the contact area.

## UNDERHOOD

Some interior noise may be caused by components under the hood or on the engine wall. The noise is then transmitted into the passenger compartment.

Causes of transmitted underhood noise include:

1. Any component mounted to the engine wall
2. Components that pass through the engine wall
3. Engine wall mounts and connectors
4. Loose radiator mounting pins
5. Hood bumpers out of adjustment
6. Hood striker out of adjustment

These noises can be difficult to isolate since they cannot be reached from the interior of the vehicle. The best method is to secure, move, or insulate one component at a time and test drive the vehicle. Also, engine RPM or load can be changed to isolate the noise. Repairs can usually be made by moving, adjusting, securing, or insulating the component causing the noise.

A  
B  
C  
D  
E  
F  
G  
H  
I  
J  
RF  
L  
M  
N  
O  
P

# SQUEAK AND RATTLE TROUBLE DIAGNOSES

< SYMPTOM DIAGNOSIS >

## Diagnostic Worksheet

INFOID:000000009010820



### SQUEAK & RATTLE DIAGNOSTIC WORKSHEET

Dear Infiniti Customer:

We are concerned about your satisfaction with your Infiniti vehicle. Repairing a squeak or rattle sometimes can be very difficult. To help us fix your Infiniti right the first time, please take a moment to note the area of the vehicle where the squeak or rattle occurs and under what conditions. You may be asked to take a test drive with a service consultant or technician to ensure we confirm the noise you are hearing.

#### I. WHERE DOES THE NOISE COME FROM? (circle the area of the vehicle)

The illustrations are for reference only, and may not reflect the actual configuration of your vehicle.

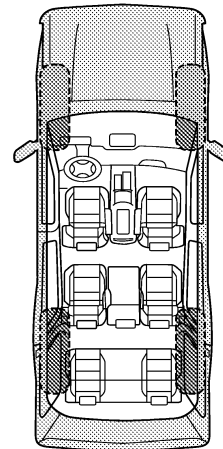
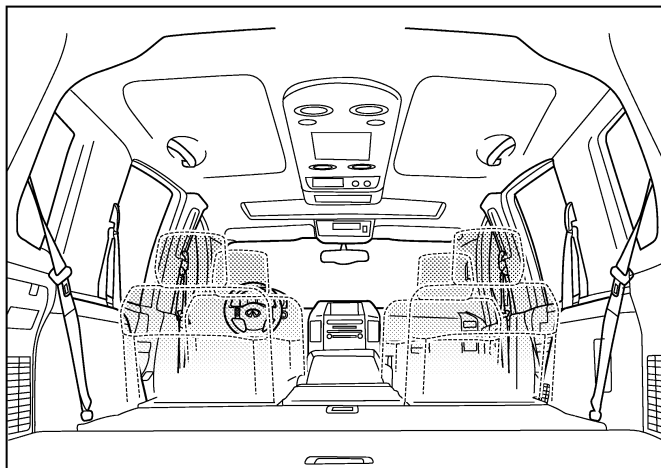
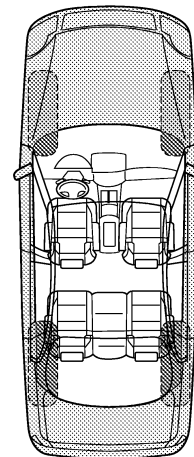
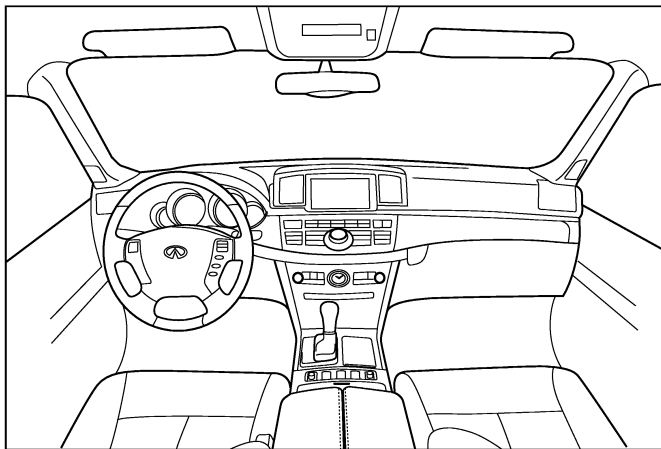

Continue to page 2 of the worksheet and briefly describe the location of the noise or rattle. In addition, please indicate the conditions which are present when the noise occurs.

PIIB8741E

# SQUEAK AND RATTLE TROUBLE DIAGNOSES

< SYMPTOM DIAGNOSIS >

## SQUEAK & RATTLE DIAGNOSTIC WORKSHEET - page 2

Briefly describe the location where the noise occurs:

---

---

### II. WHEN DOES IT OCCUR? (please check the boxes that apply)

- |   |  |
|---|--|
| <input type="checkbox"/> anytime                      | <input type="checkbox"/> after sitting out in the rain |
| <input type="checkbox"/> 1st time in the morning      | <input type="checkbox"/> when it is raining or wet     |
| <input type="checkbox"/> only when it is cold outside | <input type="checkbox"/> dry or dusty conditions       |
| <input type="checkbox"/> only when it is hot outside  | <input type="checkbox"/> other:                        |

### III. WHEN DRIVING:

- through driveways
- over rough roads
- over speed bumps
- only about \_\_\_\_ mph
- on acceleration
- coming to a stop
- on turns: left, right or either (circle)
- with passengers or cargo
- other: \_\_\_\_\_
- after driving \_\_\_\_ miles or \_\_\_\_ minutes

### IV. WHAT TYPE OF NOISE

- squeak (like tennis shoes on a clean floor)
- creak (like walking on an old wooden floor)
- rattle (like shaking a baby rattle)
- knock (like a knock at the door)
- tick (like a clock second hand)
- thump (heavy, muffled knock noise)
- buzz (like a bumble bee)

### TO BE COMPLETED BY DEALERSHIP PERSONNEL

#### Test Drive Notes:

---

---

---

	YES	NO	Initials of person performing
Vehicle test driven with customer	<input type="checkbox"/>	<input type="checkbox"/>	_____
- Noise verified on test drive	<input type="checkbox"/>	<input type="checkbox"/>	_____
- Noise source located and repaired	<input type="checkbox"/>	<input type="checkbox"/>	_____
- Follow up test drive performed to confirm repair	<input type="checkbox"/>	<input type="checkbox"/>	_____

VIN: \_\_\_\_\_ Customer Name: \_\_\_\_\_  
W.O.# \_\_\_\_\_ Date: \_\_\_\_\_

This form must be attached to Work Order

PIIB8742E

A  
B  
C  
D  
E  
F  
G  
H  
I  
J  
RF  
L  
M  
N  
O  
P

# GLASS LID

< REMOVAL AND INSTALLATION >

## REMOVAL AND INSTALLATION

### GLASS LID

Exploded View

INFOID:000000009010821

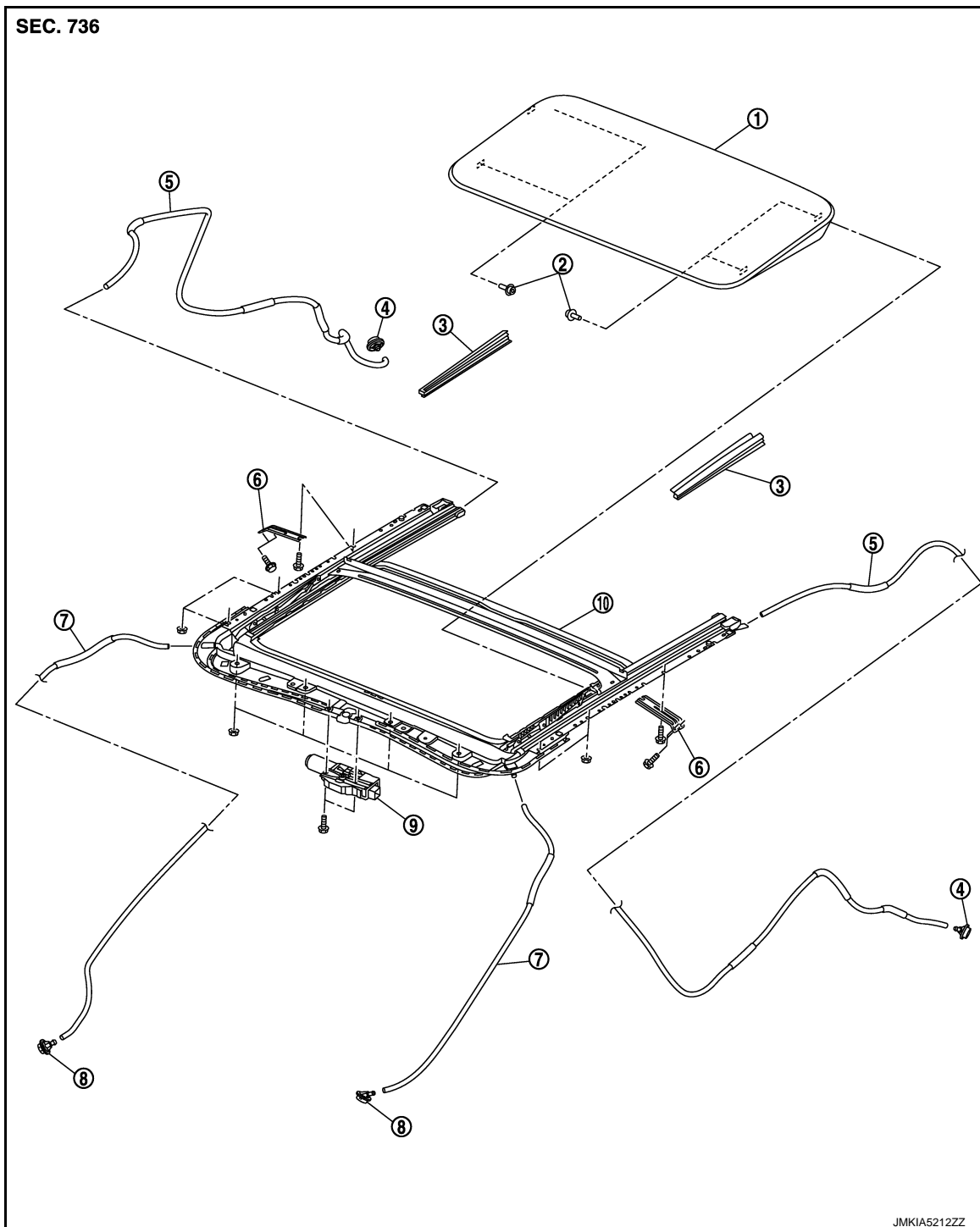

- |                           |                          |                            |
|---------------------------|--------------------------|----------------------------|
| 1. Glass lid              | 2. TORX bolt             | 3. Side trim               |
| 4. Rear drain connector   | 5. Rear drain hose       | 6. Sunroof bracket (LH,RH) |
| 7. Front drain hose       | 8. Front drain connector | 9. Sunroof motor assembly  |
| 10. Sunroof unit assembly |                          |                            |

# GLASS LID

## < REMOVAL AND INSTALLATION >

### Removal and Installation

INFOID:000000009010822

#### CAUTION:

- Always work with a helper.
- Fully close the glass lid, before removal, then never operate sunroof motor after removal.

#### REMOVAL

1. Remove the side trims (LH, RH).
2. Remove the TORX bolts (A) and remove glass lid.

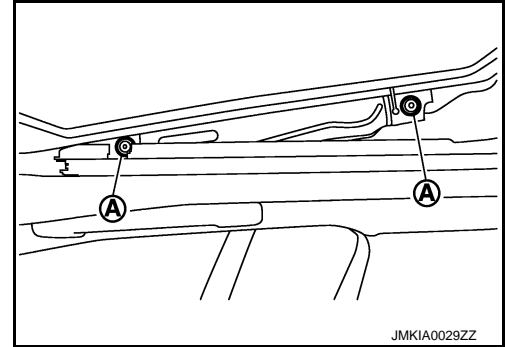

JMKIA0029ZZ

#### INSTALLATION

#### CAUTION:

After installing the glass lid, perform the leak test and check that there is no malfunction.

#### NOTE:

After installation carry out fitting adjustment. Refer to [RF-29, "Adjustment"](#).  
Install in the reverse order of removal.

#### Adjustment

INFOID:000000009010823

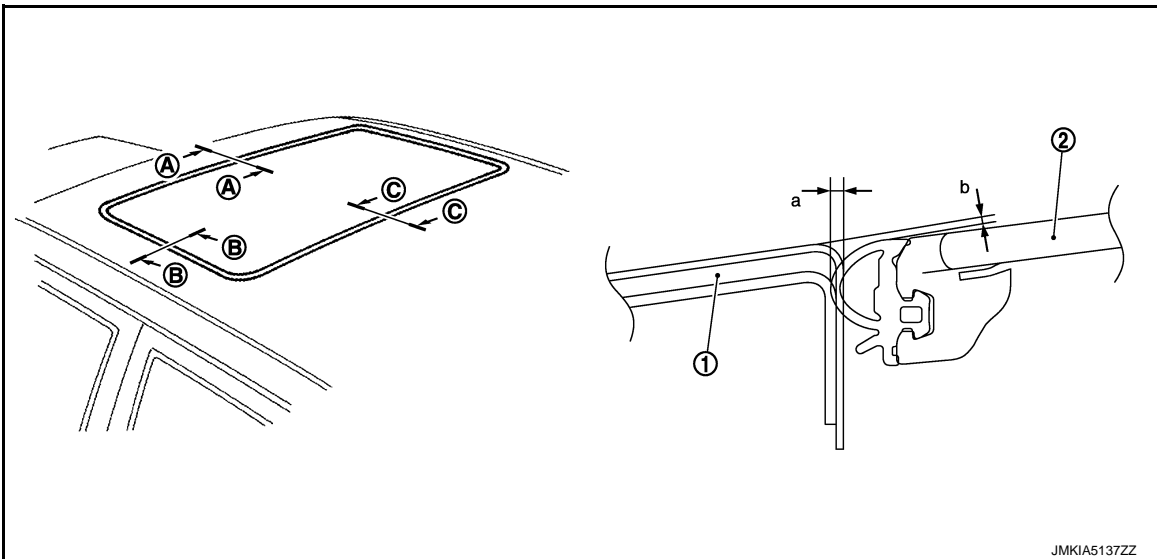

JMKIA5137ZZ

1. Roof panel
2. Glass lid

#### Glass lid Adjustment and Surface Mismatch Adjustment

1. Remove side trims.
2. After loosening glass lid from TORX bolts (left and right).
3. Adjust glass lid from outside of vehicle so it resembles "A – A", "B – B", "C – C".

Portion

A – A

a (Clearance)

0.6 – 2.2 mm (0.024 – 0.087 in)

b (Surface height difference)

-1.5 – (+1.5) mm  
[(-0.059) – (+0.059) in]

## GLASS LID

### < REMOVAL AND INSTALLATION >

---

<b>B – B</b>	<b>0.6 – 2.2 mm (0.024 – 0.087 in)</b>	<b>-1.5) – (+1.5) mm [(-0.059) – (+0.059) in]</b>
<b>C – C</b>	<b>0.6 – 2.2 mm (0.024 – 0.087 in)</b>	<b>-1.5) – (+1.5) mm [(-0.059) – (+0.059) in]</b>

4. To prevent glass lid from moving after adjustment, first tighten the TORX bolts of front left, and then tighten the TORX bolts of rear right.
5. Tighten remaining TORX bolts, being careful to prevent glass lid from moving.
6. Tilt glass lid up and down several times to check that it moves smoothly.

**NOTE:**

After adjustment the sunroof unit assembly, perform additional service. Refer to [RF-11. "ADDITIONAL SERVICE WHEN REPLACING CONTROL UNIT : Description"](#).

# SUNROOF MOTOR ASSEMBLY

< REMOVAL AND INSTALLATION >

## SUNROOF MOTOR ASSEMBLY

Exploded View

INFOID:000000009010824

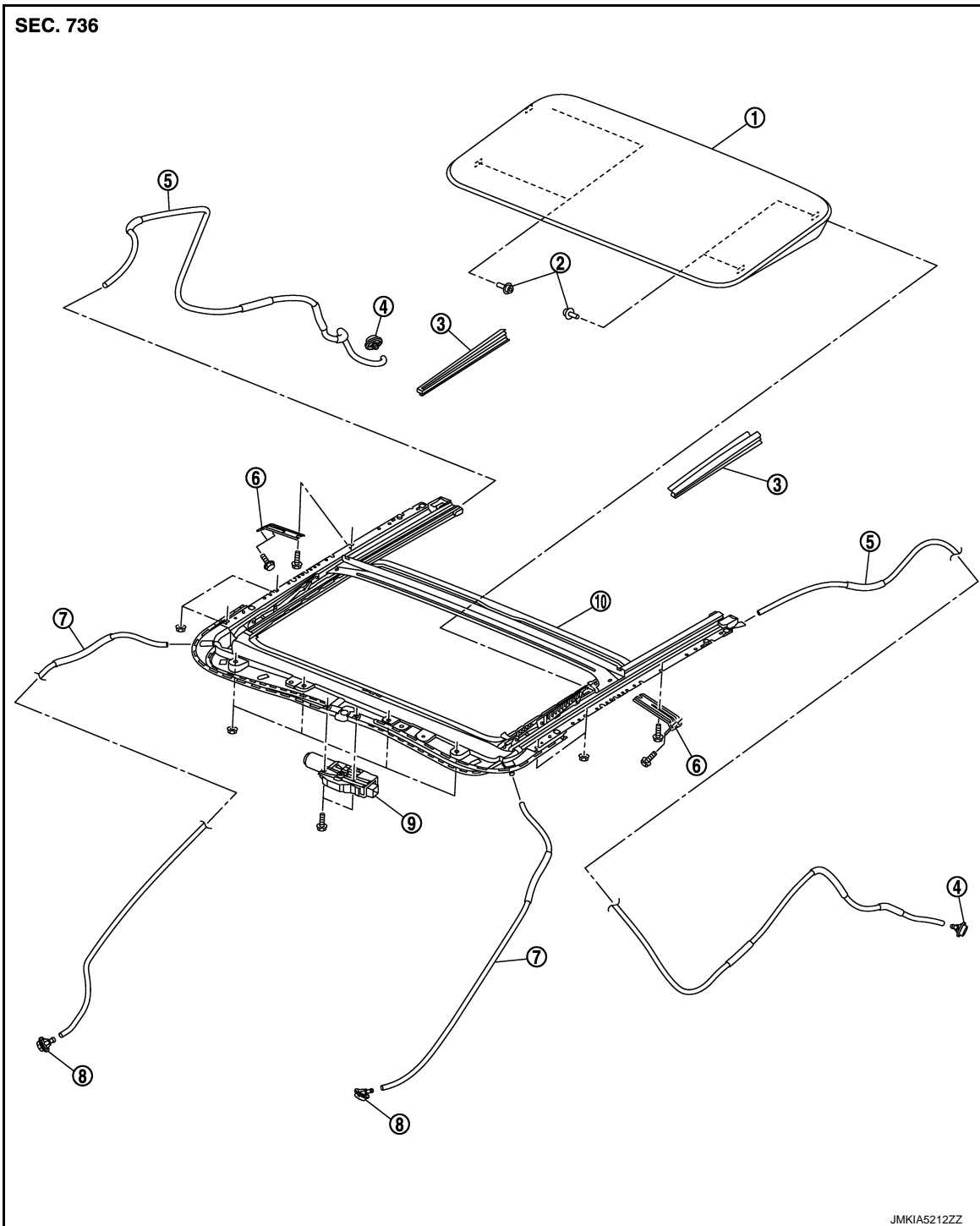

- |                           |                          |                            |
|---------------------------|--------------------------|----------------------------|
| 1. Glass lid              | 2. TORX bolt             | 3. Side trim               |
| 4. Rear drain connector   | 5. Rear drain hose       | 6. Sunroof bracket (LH,RH) |
| 7. Front drain hose       | 8. Front drain connector | 9. Sunroof motor assembly  |
| 10. Sunroof unit assembly |                          |                            |

A  
B  
C  
D  
E  
F  
G  
H  
I  
J  
RF  
L  
M  
N  
O  
P

# SUNROOF MOTOR ASSEMBLY

< REMOVAL AND INSTALLATION >

---

## Removal and Installation

INFOID:000000009010825

### REMOVAL

#### **CAUTION:**

- Before removing sunroof motor, check that glass lid is fully closed.
- After removing sunroof motor, never attempt to rotate sunroof motor assembly as a single unit.

1. Remove the headlining. Refer to [INT-28, "Removal and Installation"](#).
2. Disconnect connector from sunroof motor assembly.
3. Remove sunroof motor assembly mounting screws, and then remove sunroof motor assembly.

### INSTALLATION

#### **CAUTION:**

**Before installing the sunroof motor assembly, be sure to place the link and wire assembly in the symmetrical and fully closed position.**

1. Move the sunroof motor assembly laterally by little so that the gear is completely engaged into the wire on the sunroof unit assembly and mounting surface becomes parallel. Then secure the sunroof motor assembly with screw.
2. Install the headlining. Refer to [INT-28, "Removal and Installation"](#).



# SUNROOF UNIT ASSEMBLY

< REMOVAL AND INSTALLATION >

## SUNROOF UNIT ASSEMBLY

Exploded View

INFOID:000000009010826

REMOVAL

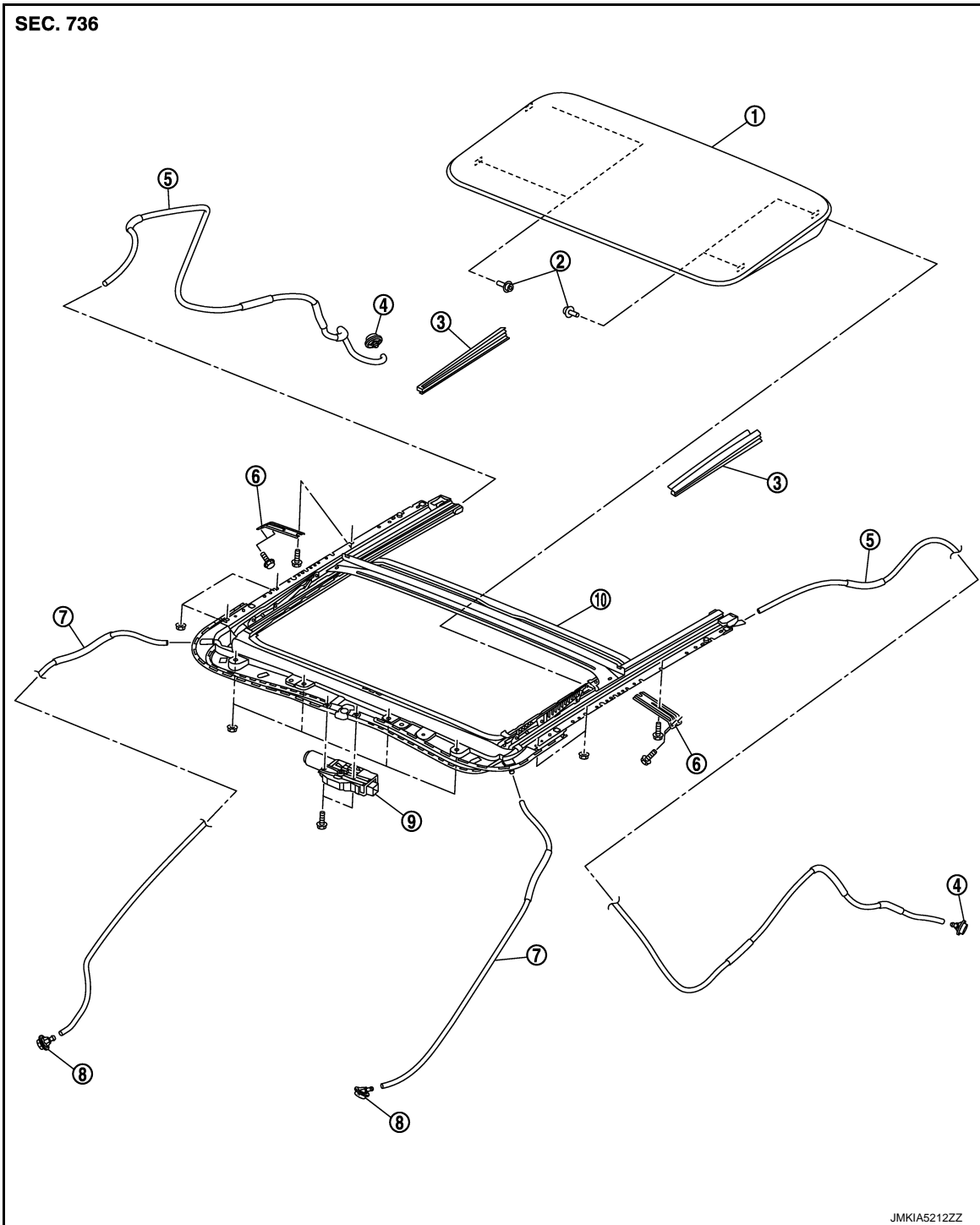

- |                           |                          |                            |
|---------------------------|--------------------------|----------------------------|
| 1. Glass lid              | 2. TORX bolt             | 3. Side trim               |
| 4. Rear drain connector   | 5. Rear drain hose       | 6. Sunroof bracket (LH,RH) |
| 7. Front drain hose       | 8. Front drain connector | 9. Sunroof motor assembly  |
| 10. Sunroof unit assembly |                          |                            |

DISASSEMBLY

A  
B  
C  
D  
E  
F  
G  
H  
I  
J  
RF  
L  
M  
N  
O  
P

# SUNROOF UNIT ASSEMBLY

< REMOVAL AND INSTALLATION >

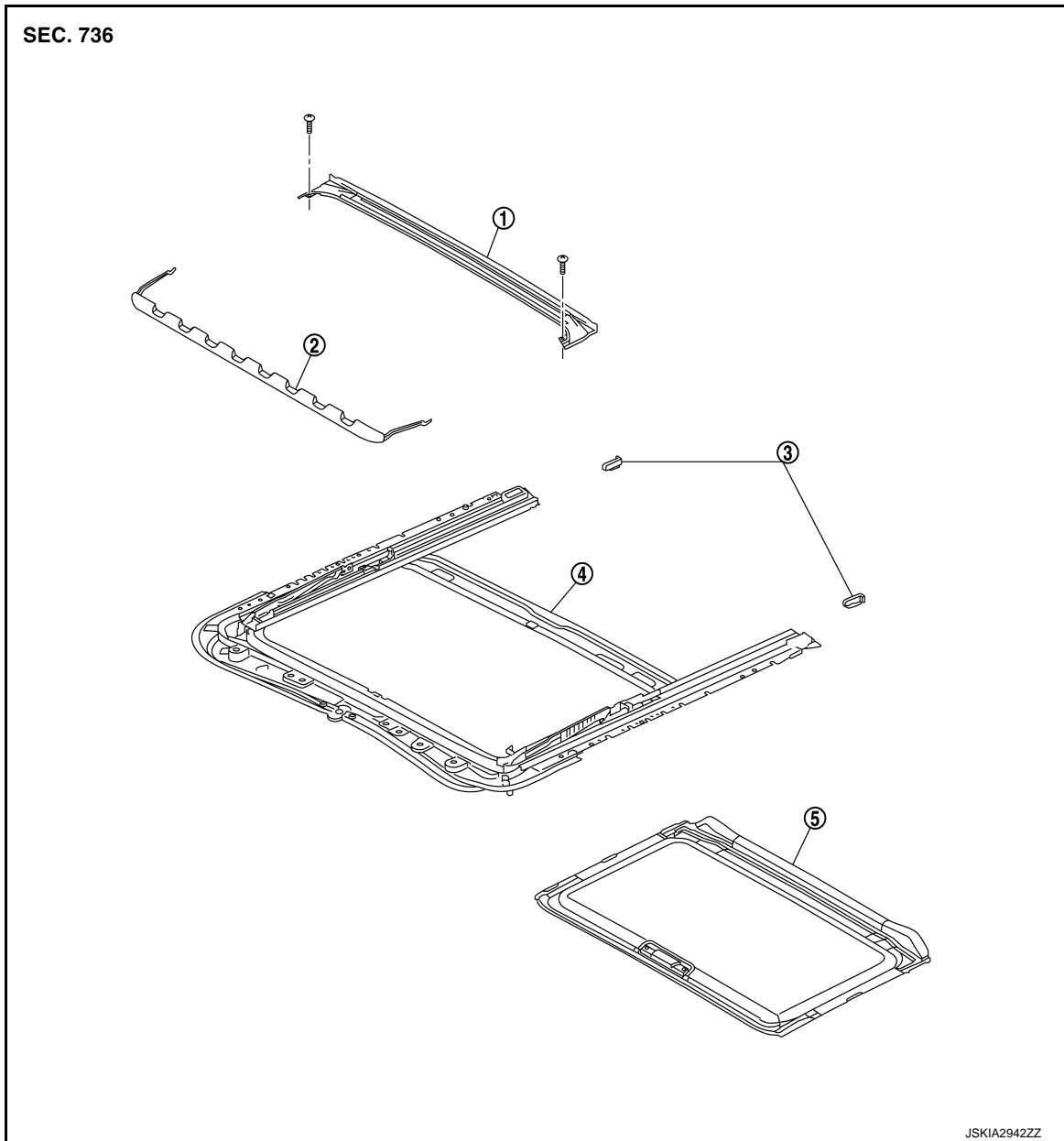

1. Rear drain assembly

2. Wind deflector

3. Sunshade stopper

4. Sunroof frame

5. Sunshade

## Removal and Installation

INFOID:000000009010827

### REMOVAL

#### CAUTION:

- Always work with a helper.
- Fully close the glass lid assembly, before removal, then never operate sunroof motor assembly after removal.
- When taking sunroof unit out, use cloths to protect the seats and trim from damage.
- After installing the sunroof unit and glass lid, perform the leak test and check that there is no malfunction.

1. Remove the headlining. Refer to [INT-28, "Removal and Installation"](#).
2. Disconnect drain hoses.
3. Remove the glass lid. Refer to [RF-29, "Removal and Installation"](#).
4. Remove the sunroof motor assembly. Refer to [RF-32, "Removal and Installation"](#).

# SUNROOF UNIT ASSEMBLY

## < REMOVAL AND INSTALLATION >

---

5. Remove grip bracket.
6. Remove sunroof bracket bolts. A
7. Remove nuts from the front end and side rail, and then remove sunroof unit assembly from roof panel.
8. Remove sunroof unit assembly through the passenger compartment while being careful not to damage the seats and trim. B

## INSTALLATION

1. Temporarily tighten the mounting nuts to the side rail of sunroof unit assembly. C
2. Temporarily tighten the mounting nuts to the front end of sunroof unit assembly.
3. Temporarily tighten the mounting bolts to the sunroof brackets (LH,RH).
4. Tighten the installation points diagonally excluding the installation points of the sunroof brackets around the roof opening. D
5. Tighten the mounting nuts to the front end and side rail.
6. Tighten the sunroof bracket bolts of the vehicle side, and then tighten the bolt of the rail side. E
7. Install the glass lid.  
**NOTE:**  
After installation, perform fitting adjustment. Refer to [RF-29, "Adjustment"](#). F
8. Connect drain hoses.
9. Install headlining. Refer to [INT-28, "Removal and Installation"](#). G

## Disassembly and Assembly

INFOID:000000009010828

## DISASSEMBLY

1. Remove sunshade stopper mounting from the rear end of sunroof frame. H
2. Remove rear drain assembly from sunroof guide assembly.
3. Remove sunshade from the rear end of sunroof frame. I

## ASSEMBLY

Assemble in the reverse order of disassembly. J

RF

L

M

N

O

P

# SUNSHADE

< REMOVAL AND INSTALLATION >

## SUNSHADE

Exploded View

INFOID:000000009010829

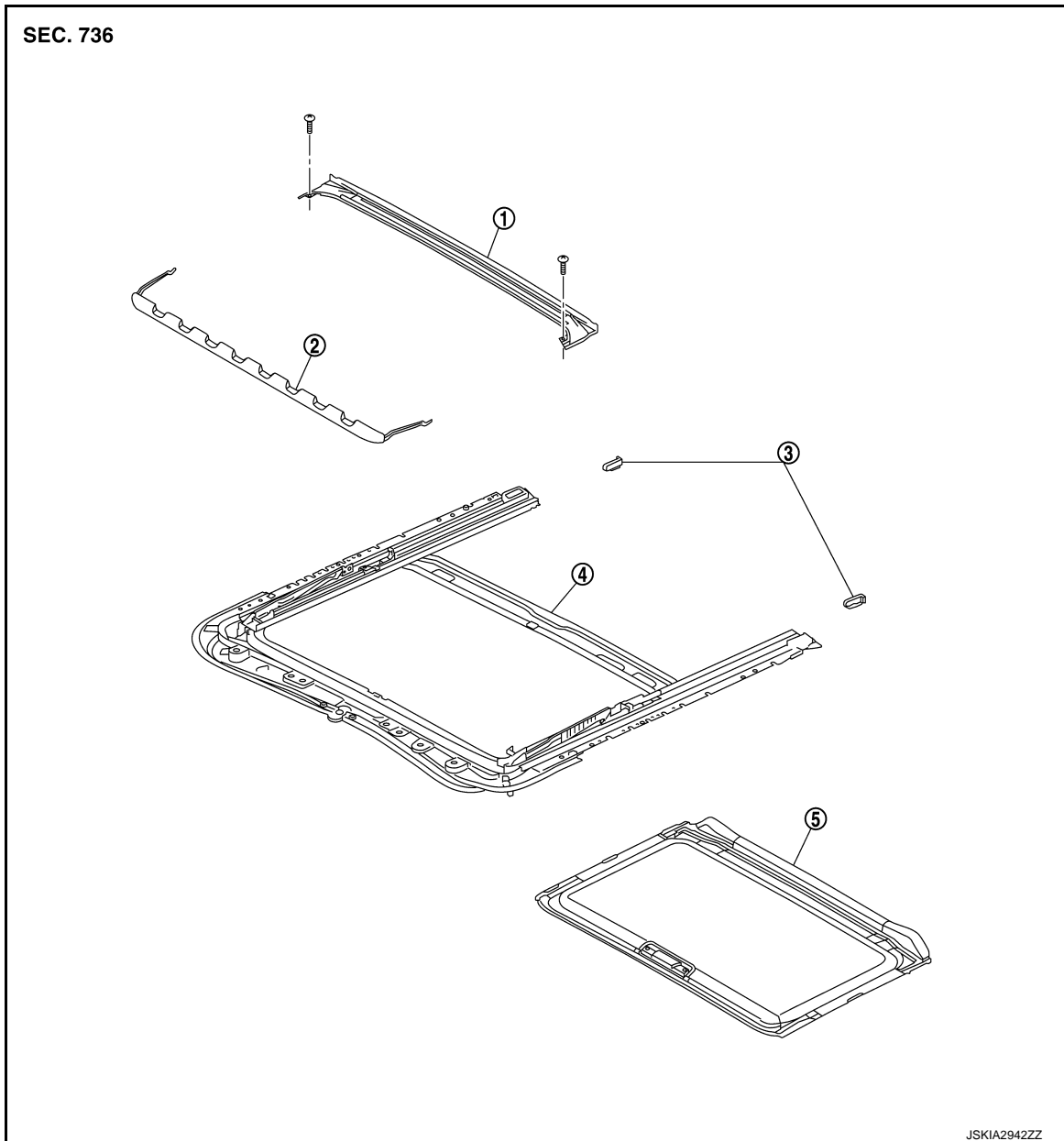

1. Rear drain assembly

2. Wind deflector

3. Sunshade stopper

4. Sunroof frame

5. Sunshade

## Removal and Installation

INFOID:000000009010830

### REMOVAL

1. Remove the headlining. Refer to [INT-28, "Removal and Installation"](#).
2. Remove the sunshade stopper mounting from the rear end of sunroof frame.
3. Remove the sunshade from the rear end of sunroof frame.

### INSTALLATION

Install in the reverse order of removal.

# SUNROOF SWITCH

< REMOVAL AND INSTALLATION >

---

## SUNROOF SWITCH

### Removal and Installation

INFOID:000000009010831

#### Removal

Remove the map lamp assembly (sunroof switch). Refer to [INT-28. "Removal and Installation"](#).

#### Installation

Install in the reverse order of removal.

A

B

C

D

E

F

G

H

I

J

RF

L

M

N

O

P