

SECTION **SRC**

SRS AIRBAG CONTROL SYSTEM

A
B
C
D
E
F
G
SRC
I
J
K
L
M
N
O
P

CONTENTS

<p>PRECAUTION 4</p> <p>PRECAUTIONS 4</p> <p style="padding-left: 20px;">Precaution for Supplemental Restraint System (SRS) "AIR BAG" and "SEAT BELT PRE-TENSIONER"4</p> <p style="padding-left: 20px;">Precaution for SRS "AIR BAG" and "SEAT BELT PRE-TENSIONER" Service4</p> <p>SYSTEM DESCRIPTION 5</p> <p>COMPONENT PARTS 5</p> <p style="padding-left: 20px;">Component Parts Location5</p> <p style="padding-left: 20px;">Component Description6</p> <p style="padding-left: 20px;">Driver Air Bag Module6</p> <p style="padding-left: 20px;">Front Passenger Air Bag Module7</p> <p style="padding-left: 20px;">Front Side Air Bag Module7</p> <p style="padding-left: 20px;">Side Curtain Air Bag Module7</p> <p style="padding-left: 20px;">Front Seat Belt Pre-tensioner7</p> <p style="padding-left: 20px;">Air Bag Diagnosis Sensor Unit8</p> <p style="padding-left: 20px;">Crash Zone Sensor8</p> <p style="padding-left: 20px;">Front Side Air Bag Satellite Sensor8</p> <p style="padding-left: 20px;">Rear Side Air Bag Satellite Sensor8</p> <p style="padding-left: 20px;">Front Door Satellite Sensor9</p> <p style="padding-left: 20px;">SRS Component Connectors9</p> <p>SYSTEM11</p> <p>SRS AIR BAG SYSTEM 11</p> <p style="padding-left: 20px;">SRS AIR BAG SYSTEM : System Diagram 11</p> <p style="padding-left: 20px;">SRS AIR BAG SYSTEM : System Description 11</p> <p>OCCUPANT CLASSIFICATION SYSTEM 11</p> <p style="padding-left: 20px;">OCCUPANT CLASSIFICATION SYSTEM : System Diagram 12</p> <p style="padding-left: 20px;">OCCUPANT CLASSIFICATION SYSTEM : System Description 12</p> <p>SEAT BELT WARNING LAMP SYSTEM 13</p> <p style="padding-left: 20px;">SEAT BELT WARNING LAMP SYSTEM : System Diagram 13</p>	<p style="padding-left: 20px;">SEAT BELT WARNING LAMP SYSTEM : System Description14</p> <p>DIAGNOSIS SYSTEM (AIR BAG) 15</p> <p style="padding-left: 20px;">Diagnosis Description 15</p> <p style="padding-left: 20px;">SRS Operation Check 15</p> <p style="padding-left: 20px;">Trouble Diagnosis with CONSULT 16</p> <p style="padding-left: 20px;">Trouble Diagnosis without CONSULT 17</p> <p style="padding-left: 20px;">SRS History Check 17</p> <p style="padding-left: 20px;">SRS Final Check 17</p> <p style="padding-left: 20px;">CONSULT Function (AIR BAG) 17</p> <p style="padding-left: 20px;">CONSULT Function (OCCUPANT DETECTION)....18</p> <p>ECU DIAGNOSIS INFORMATION 19</p> <p>DIAGNOSIS SENSOR UNIT 19</p> <p style="padding-left: 20px;">DTC Index 19</p> <p style="padding-left: 20px;">Flash Code Index 23</p> <p>WIRING DIAGRAM 26</p> <p>SRS AIR BAG SYSTEM 26</p> <p style="padding-left: 20px;">Wiring Diagram 26</p> <p>BASIC INSPECTION 40</p> <p>DIAGNOSIS AND REPAIR WORK FLOW 40</p> <p style="padding-left: 20px;">Work Flow 40</p> <p>INSPECTION AND ADJUSTMENT 42</p> <p>ADDITIONAL SERVICE WHEN REPLACING CONTROL UNIT 42</p> <p style="padding-left: 20px;">ADDITIONAL SERVICE WHEN REPLACING CONTROL UNIT : Description 42</p> <p style="padding-left: 20px;">ADDITIONAL SERVICE WHEN REPLACING CONTROL UNIT : Special Repair Requirement 42</p> <p>ZERO POINT RESET 42</p> <p style="padding-left: 20px;">ZERO POINT RESET : Description 42</p> <p style="padding-left: 20px;">ZERO POINT RESET : Special Repair Requirement 42</p>
--	---

INTERMITTENT INCIDENT	43	B0096 FRONT SIDE AIR BAG SATELLITE	
Inspection Procedure	43	SENSOR RH	66
Trouble Diagnosis with CONSULT	43	Description	66
DTC/CIRCUIT DIAGNOSIS	44	DTC Logic	66
U1000 CAN COMM CIRCUIT	44	Diagnosis Procedure	67
Description	44	B0092 REAR SIDE AIR BAG SATELLITE	
DTC Logic	44	SENSOR LH	69
Diagnosis Procedure	44	Description	69
U1010 CONTROL UNIT (CAN)	45	DTC Logic	69
Description	45	Diagnosis Procedure	69
DTC Logic	45	B0097 REAR SIDE AIR BAG SATELLITE	
Diagnosis Procedure	45	SENSOR RH	72
B0001, B0002 DRIVER AIRBAG MODULE	46	Description	72
Description	46	DTC Logic	72
DTC Logic	46	Diagnosis Procedure	73
Diagnosis Procedure	47	B0093 FRONT DOOR SATELLITE SENSOR	
B0010, B0011 PASSENGER AIRBAG MOD- ULE	49	LH	75
Description	49	Description	75
DTC Logic	49	DTC Logic	75
Diagnosis Procedure	50	Diagnosis Procedure	75
B0020 SIDE AIRBAG MODULE LH	52	B0098 FRONT DOOR SATELLITE SENSOR	
Description	52	RH	78
DTC Logic	52	Description	78
Diagnosis Procedure	52	DTC Logic	78
B0028 SIDE AIRBAG MODULE RH	54	Diagnosis Procedure	78
Description	54	B00A0 OCS SYSTEM	81
DTC Logic	54	Description	81
Diagnosis Procedure	54	DTC Logic	81
B0021 SIDE CURTAIN AIR BAG MODULE LH	56	Diagnosis Procedure	82
Description	56	B00D5 PASSENGER AIR BAG OFF INDICA- TOR	84
DTC Logic	56	Description	84
Diagnosis Procedure	56	DTC Logic	84
B0029 SIDE CURTAIN AIR BAG MODULE	58	Diagnosis Procedure	84
RH	58	B1428 SEAT BELT BUCKLE SWITCH LH	87
Description	58	Description	87
DTC Logic	58	DTC Logic	87
Diagnosis Procedure	58	Diagnosis Procedure	87
B0094 CRASH ZONE SENSOR	60	B1429 SEAT BELT BUCKLE SWITCH RH	89
Description	60	Description	89
DTC Logic	60	DTC Logic	89
Diagnosis Procedure	61	Diagnosis Procedure	89
B0091 FRONT SIDE AIR BAG SATELLITE		B1430 SEAT BELT PRE-TENSIONER	91
SENSOR LH	63	Description	91
Description	63	DTC Logic	91
DTC Logic	63	Diagnosis Procedure	91
Diagnosis Procedure	64	B1431 SEAT BELT PRE-TENSIONER	93
B0096 FRONT SIDE AIR BAG SATELLITE		Description	93
SENSOR RH	66	DTC Logic	93
Description	66	Diagnosis Procedure	93
DTC Logic	66		
Diagnosis Procedure	67		

B1432 LAP PRE-TENSIONER	95	Diagnosis Procedure	103
DTC Logic	95		
Diagnosis Procedure	95		
B1433 LAP PRE-TENSIONER	97	B14XX AIR BAG DIAGNOSIS SENSOR UNIT.	104
DTC Logic	97	Description	104
Diagnosis Procedure	97	DTC Logic	104
		Diagnosis Procedure	104
B1436 ACTIVE VENT	99	SYMPTOM DIAGNOSIS	106
DTC Logic	99		
Diagnosis Procedure	99	SRS AIR BAG WARNING LAMP DOES NOT	
		TURN ON	106
B142A IGNITION VOLTAGE	101	AIR BAG Warning Lamp Does Not Turn On	106
Description	101		
DTC Logic	101	SRS AIR BAG WARNING LAMP DOES NOT	
Diagnosis Procedure	101	TURN OFF	107
		AIR BAG Warning Lamp Does Not Turn Off	107
B142X COLLISION DETECTION	103	SEAT BELT WARNING SYSTEM	108
Description	103	Seat Belt Warning System Does Not Function	108
DTC Logic	103		

A
B
C
D
E
F
G
I
J
K
L
M
N
O
P

SRC

PRECAUTIONS

< PRECAUTION >

PRECAUTION

PRECAUTIONS

Precaution for Supplemental Restraint System (SRS) "AIR BAG" and "SEAT BELT PRE-TENSIONER"

INFOID:000000009134349

The Supplemental Restraint System such as "AIR BAG" and "SEAT BELT PRE-TENSIONER", used along with a front seat belt, helps to reduce the risk or severity of injury to the driver and front passenger for certain types of collision. This system includes dual stage front air bag modules. The SRS system may only deploy one front air bag, depending on the severity of a collision and whether the front passenger seat is occupied. Information necessary to service the system safely is included in the SR and SB section of this Service Manual.

WARNING:

- To avoid rendering the SRS inoperative, which could increase the risk of personal injury or death in the event of a collision which would result in air bag inflation, all maintenance must be performed by an authorized NISSAN/INFINITI dealer.
- Improper maintenance, including incorrect removal and installation of the SRS, can lead to personal injury caused by unintentional activation of the system. For removal of Spiral Cable and Air Bag Module, see the SR section.
- Do not use electrical test equipment on any circuit related to the SRS unless instructed to in this Service Manual. SRS wiring harnesses can be identified by yellow and/or orange harnesses or harness connectors.

PRECAUTIONS WHEN USING POWER TOOLS (AIR OR ELECTRIC) AND HAMMERS

WARNING:

- When working near the Airbag Diagnosis Sensor Unit or other Airbag System sensors with the Ignition ON or engine running, DO NOT use air or electric power tools or strike near the sensor(s) with a hammer. Heavy vibration could activate the sensor(s) and deploy the air bag(s), possibly causing serious injury.
- When using air or electric power tools or hammers, always switch the Ignition OFF, disconnect the battery and wait at least three minutes before performing any service.

Precaution for SRS "AIR BAG" and "SEAT BELT PRE-TENSIONER" Service

INFOID:000000009134350

- Do not use electrical test equipment to check SRS circuits unless instructed to in this Service Manual.
- Before servicing the SRS, turn ignition switch OFF, disconnect both battery cables and wait at least 3 minutes.
For approximately 3 minutes after the cables are removed, it is still possible for the air bag and seat belt pretensioner to deploy. Therefore, do not work on any SRS connectors or wires until at least 3 minutes have passed.
- The air bag diagnosis sensor unit must always be installed with the arrow mark "←" pointing toward the front of the vehicle for proper operation. Also check air bag diagnosis sensor unit for cracks, deformities or rust before installation and replace as required.
- The spiral cable must be aligned with the neutral position since its rotations are limited. Do not attempt to turn steering wheel or column after removal of steering gear.
- Handle air bag module carefully. Always place driver and front passenger air bag modules with the pad side facing upward and seat mounted front side air bag module standing with the stud bolt side facing down.
- Conduct self-diagnosis to check entire SRS for proper function after replacing any components.
- After air bag inflates, the front instrument panel assembly should be replaced if damaged.

COMPONENT PARTS

< SYSTEM DESCRIPTION >

SYSTEM DESCRIPTION

COMPONENT PARTS

Component Parts Location

INFOID:000000009134351

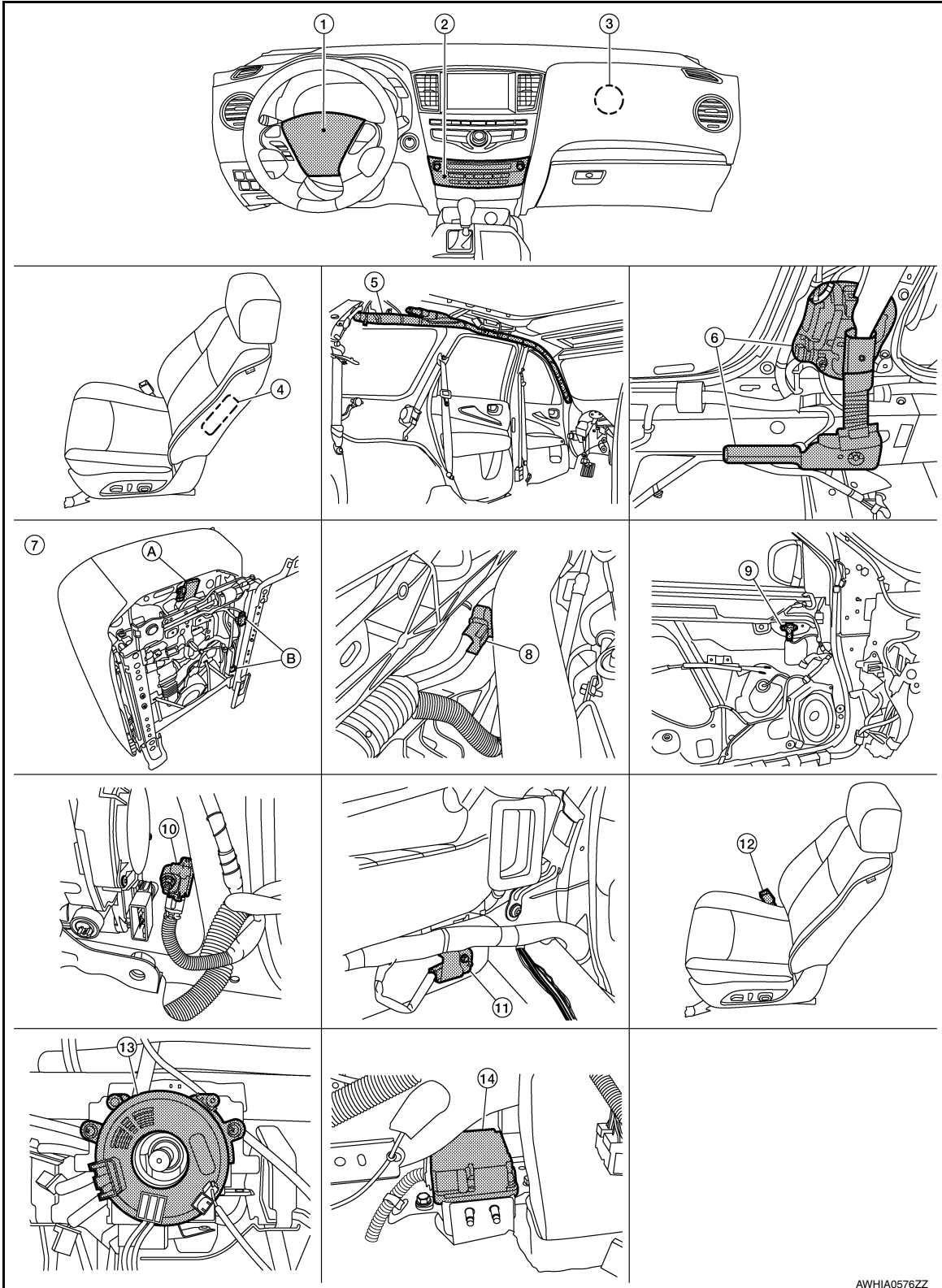

A
B
C
D
E
F
G
H
I
J
K
L
M
N
O
P

SRC

AWHIA0576ZZ

COMPONENT PARTS

< SYSTEM DESCRIPTION >

- | | | |
|--|---|--|
| 1. Driver air bag module | 2. Front passenger air bag off indicator | 3. Front passenger air bag module |
| 4. Front LH side air bag module (RH similar) | 5. LH side curtain air bag module (view with headliner removed) (RH similar) | 6. Front RH seatbelt pre-tensioner (view with lower center pillar cover RH removed) (LH similar) |
| 7. Occupant classification system control unit (A)
Occupant classification system sensors (B)
(view with front passenger seat removed) | 8. Crash zone sensor
(view with air intake removed) | 9. Front door satellite sensor LH
(view with front door finisher LH removed)
(RH similar) |
| 10. Front side air bag satellite sensor LH
(view with lower center pillar cover LH removed)
(RH similar) | 11. Rear side air bag satellite sensor LH
(view with luggage side lower finisher LH removed)
(RH similar) | 12. Seat belt buckle switch (driver seat)
(passenger seat similar) |
| 13. Spiral cable
(view with steering wheel removed) | 14. Air bag diagnosis sensor unit
(view with center console assembly removed) | |

Component Description

INFOID:000000009134352

Component	Function
Air bag diagnosis sensor unit	Refer to SRC-8, "Air Bag Diagnosis Sensor Unit" .
Driver air bag module	Refer to SRC-6, "Driver Air Bag Module" .
Front passenger air bag module	Refer to SRC-7, "Front Passenger Air Bag Module" .
Front side air bag module	Refer to SRC-7, "Front Side Air Bag Module" .
Side curtain air bag module	Refer to SRC-7, "Side Curtain Air Bag Module" .
Front seat belt pre-tensioner	Refer to SRC-7, "Front Seat Belt Pre-tensioner" .
Occupant classification system (if equipped)	Refer to SRC-12, "OCCUPANT CLASSIFICATION SYSTEM : System Description" .
Crash zone sensor	Refer to SRC-8, "Crash Zone Sensor" .
Front side air bag (satellite) sensor	Refer to SRC-8, "Front Side Air Bag Satellite Sensor" .
Rear side air bag (satellite) sensor	Refer to SRC-8, "Rear Side Air Bag Satellite Sensor" .
Front door (satellite) sensor (if equipped)	Refer to SRC-9, "Front Door Satellite Sensor" .
Seat belt buckle switch	The seat belt buckle switches (driver seat/passenger seat) provide the seat belt buckle signals to the air bag diagnosis sensor unit and the combination meter.
Spiral cable	The spiral cable provides a rotating physical connection to the driver air bag module.
Combination meter	The combination meter displays the air bag warning lamp and the seat belt warning lamp. The air bag warning lamp is used for diagnosis in User Mode and may be used to display diagnostic trouble codes without the use of the CONSULT.

Driver Air Bag Module

INFOID:000000009134353

The driver air bag module is dual stage and located in the steering wheel assembly. It operates with the SRS system in a frontal collision exceeding a specified level.

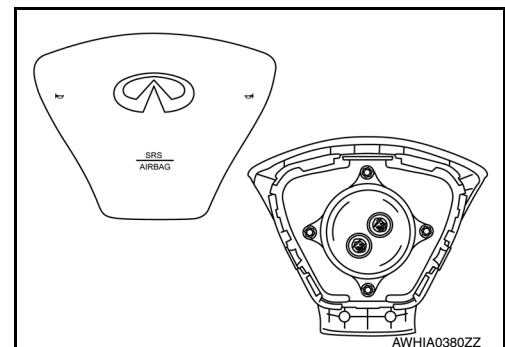

COMPONENT PARTS

< SYSTEM DESCRIPTION >

Front Passenger Air Bag Module

INFOID:000000009134354

The front passenger air bag module is located behind the instrument panel assembly. It operates with the SRS system in a frontal collision exceeding a specified level. Refer to [SRC-11, "SRS AIR BAG SYSTEM : System Description"](#) for more information.

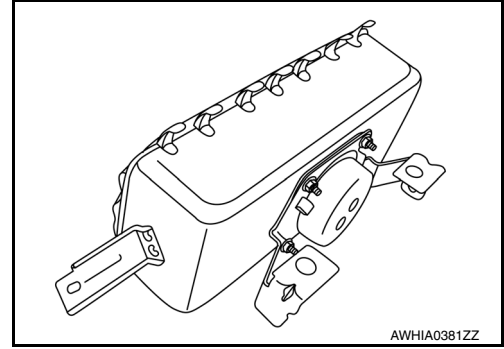

Front Side Air Bag Module

INFOID:000000009134355

Front side air bag modules are built into the front seatback assemblies. Vehicles with side air bags are equipped with labels as shown.

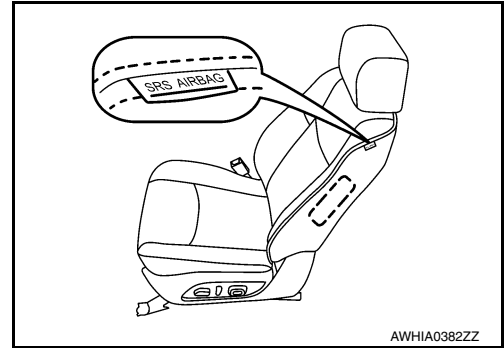

Side Curtain Air Bag Module

INFOID:000000009134356

Side curtain air bag modules are located above the vehicle headlining. Vehicles with side curtain air bags are equipped with labels on the pillar upper finishers.

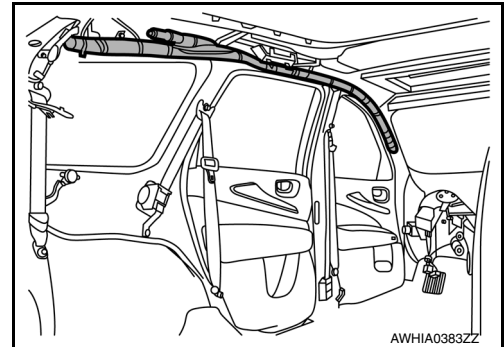

Front Seat Belt Pre-tensioner

INFOID:000000009724825

The seat belt pre-tensioner system with load limiter is installed for both the driver's seat and the front passenger's seat. It operates simultaneously with the SRS air bag system in the event of a frontal collision with an impact exceeding a specified level.

When the frontal collision with an impact exceeding a specified level occurs, seat belt slack resulting from clothing or other factors is immediately taken up by the shoulder belt pre-tensioner (1) as well as the lap belt pre-tensioner (2). Vehicle passengers are securely restrained.

When passengers in a vehicle are thrown forward in a collision and the restraining force of the seat belt exceeds a specified level, the load limiter permits the specified extension of the seat belt by the twisting of the ELR shaft, and a relaxation of the chest-area seat belt web tension while maintaining force.

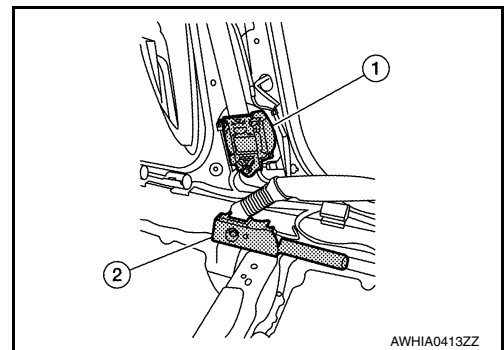

A
B
C
D
E
F
G
SRC
I
J
K
L
M
N
O
P

COMPONENT PARTS

< SYSTEM DESCRIPTION >

Air Bag Diagnosis Sensor Unit

INFOID:000000009134358

The air bag diagnosis sensor unit is located under the center console assembly. The air bag diagnosis sensor unit receives signals from multiple SRS sensors and controls the deployment of the air bags. The deployment of the air bags depends on the type and severity of the collision. The air bag diagnosis sensor unit has self-diagnosis capability through the use of the CONSULT as well as flash codes displayed by the air bag warning lamp.

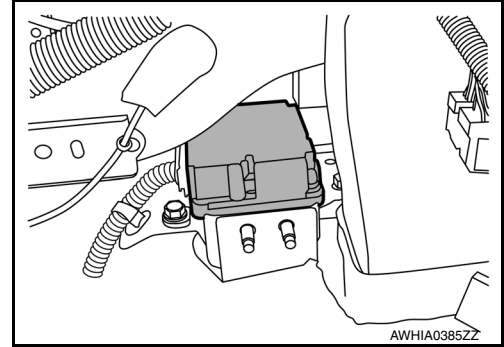

Crash Zone Sensor

INFOID:000000009134359

The crash zone sensor is located behind the radiator and underneath the front air duct. The crash zone sensor sends signals to the air bag diagnosis sensor unit during a frontal collision. This sensor may be identified by a yellow connector.

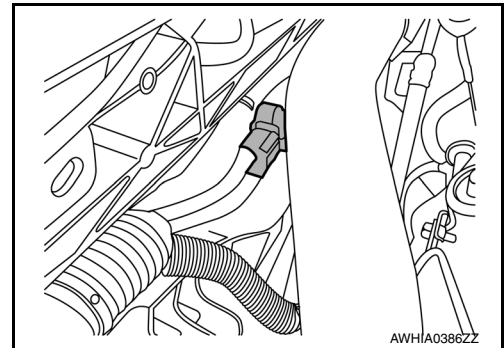

Front Side Air Bag Satellite Sensor

INFOID:000000009134360

The front side air bag satellite sensors are located on the front center pillar LH and RH next to the seat belt pretensioners. The front side air bag satellite sensors send signals to the air bag diagnosis sensor unit during a side collision. These sensors may be identified by yellow connectors.

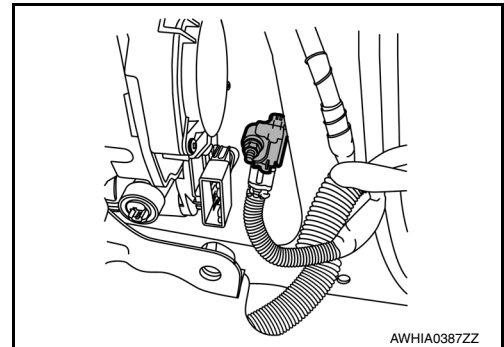

Rear Side Air Bag Satellite Sensor

INFOID:000000009134361

The rear side air bag satellite sensors are located behind the luggage side lower finisher LH and RH. The rear side air bag satellite sensors send signals to the air bag diagnosis sensor unit during a side collision. These sensors may be identified by yellow connectors.

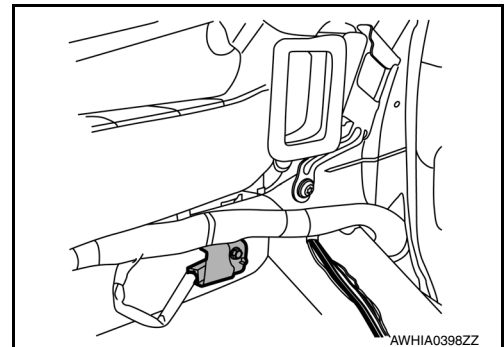

COMPONENT PARTS

< SYSTEM DESCRIPTION >

Front Door Satellite Sensor

INFOID:000000009134362

The front door satellite sensors are located in the driver and passenger doors. The front door satellite sensors send signals to the air bag diagnosis sensor unit during a side collision. These sensors may be identified by yellow connectors.

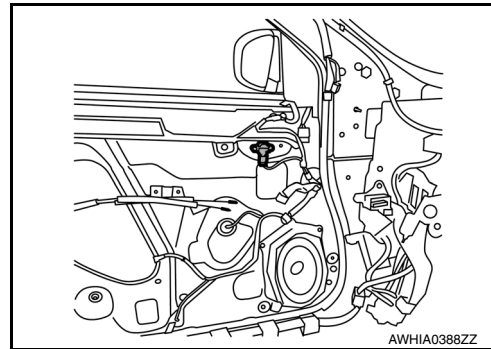

SRS Component Connectors

INFOID:000000009134363

DIRECT CONNECT

The following SRS components use direct-connect style harness connectors.

- Driver front air bag module
- Passenger front air bag module
- LH side curtain air bag module
- RH side curtain air bag module
- Front LH seat belt pre-tensioner
- Front RH seat belt pre-tensioner

Always pull up to release locking tab prior to removing connector from SRS component.

Always push down to lock locking tab after installing connector to SRS component. When locked, the locking tab is level with the connector housing.

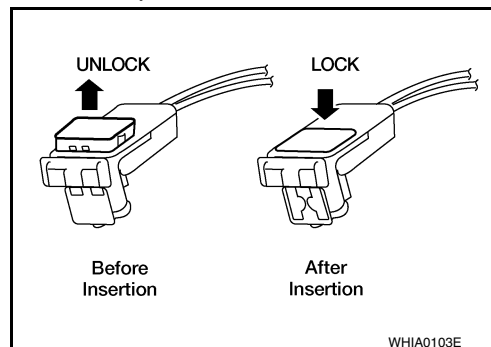

SLIDE DOUBLE LOCKING

- A new style slide double locking type connector is used on certain systems and components, especially those related to airbag control systems.
- The slide double locking type connectors help prevent incomplete locking and accidental looseness or disconnection.
- The slide double locking type connectors are disconnected by pushing or pulling the slider. Refer to the figure below.

CAUTION:

A
B
C
D
E
F
G
SRC
I
J
K
L
M
N
O
P

COMPONENT PARTS

< SYSTEM DESCRIPTION >

- Do not pull the harness or wires when disconnecting the connector.

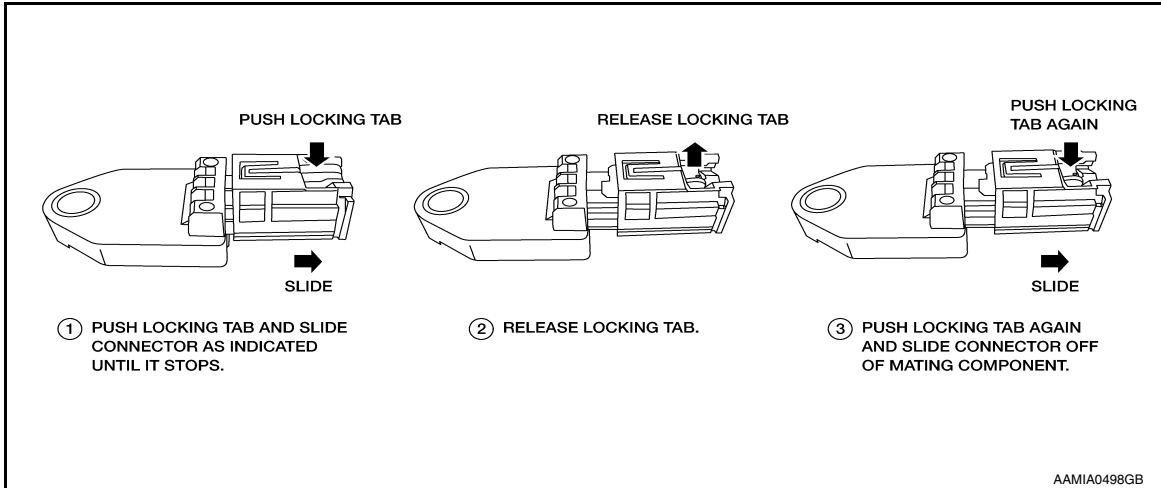

SYSTEM

< SYSTEM DESCRIPTION >

SYSTEM

SRS AIR BAG SYSTEM

SRS AIR BAG SYSTEM : System Diagram

INFOID:000000009134364

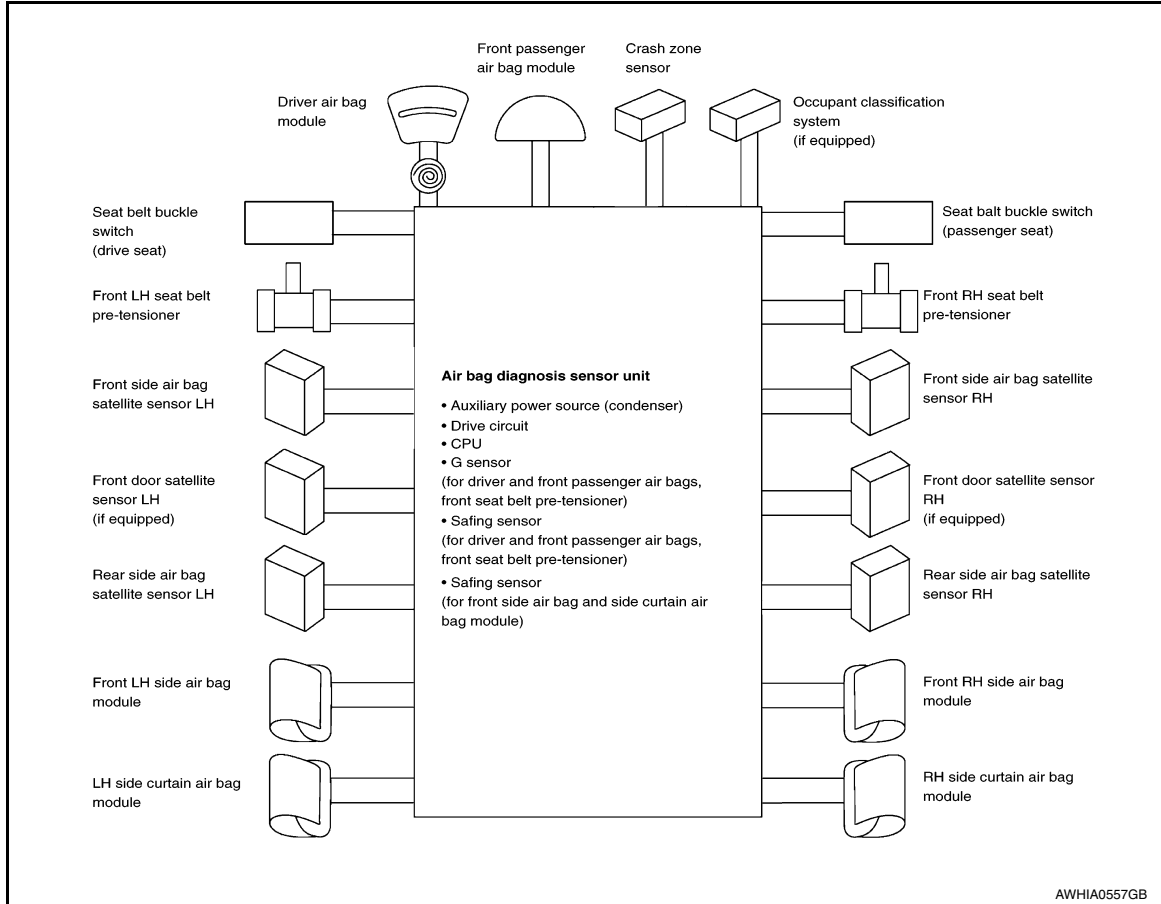

AWHIA0557GB

SRS AIR BAG SYSTEM : System Description

INFOID:000000009134365

- The air bag deploys if the air bag diagnosis sensor unit is activated while the ignition switch is in the ON or START position.
- The collision modes for which supplemental restraint systems are activated are different among the SRS systems. For example, the driver air bag module, front passenger air bag module and front seat belt pre-tensioners are activated in a frontal collision but not in a side collision.

SRS Collision Modes

SRS configuration	Frontal collision	Left side collision	Right side collision	Rollover
Driver air bag module	x	—	—	—
Front passenger air bag module	x	—	—	—
Front LH seat belt pre-tensioner	x	—	—	x
Front RH seat belt pre-tensioner	x	—	—	x
Front LH side air bag module	—	x	—	—
Front RH side air bag module	—	—	x	—
LH side curtain air bag module	—	x	—	x
RH side curtain air bag module	—	—	x	x

OCCUPANT CLASSIFICATION SYSTEM

A
B
C
D
E
F
G
I
J
K
L
M
N
O
P

SRC

SYSTEM

< SYSTEM DESCRIPTION >

OCCUPANT CLASSIFICATION SYSTEM : System Diagram

INFOID:000000009134366

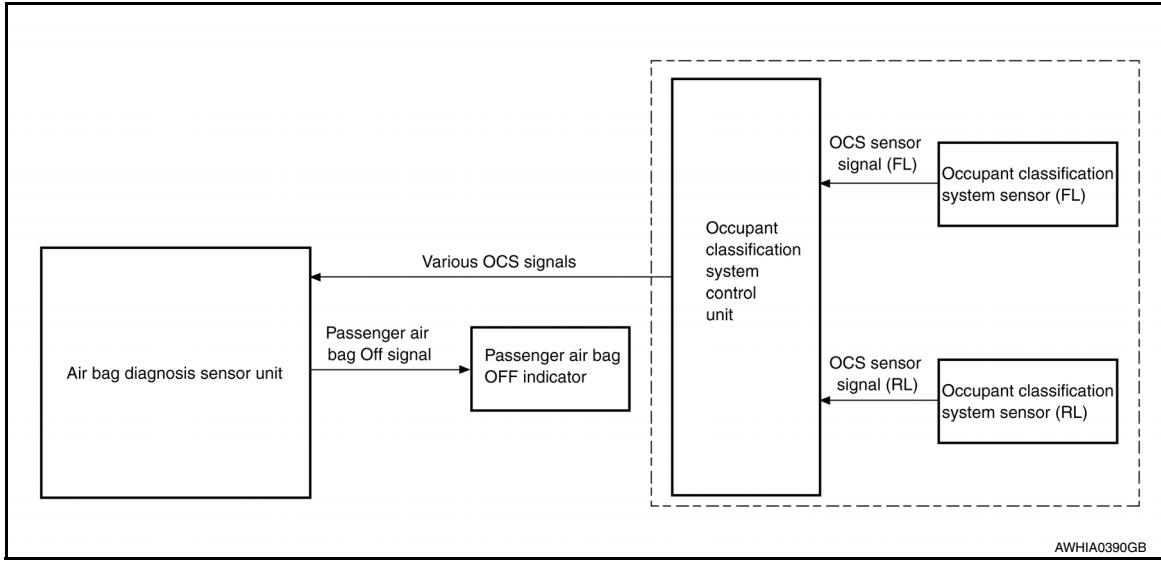

OCCUPANT CLASSIFICATION SYSTEM : System Description

INFOID:000000009134367

The occupant classification system (OCS) identifies different size occupants, out of position occupants, and detects if a child seat is present in the front passenger seat. The OCS control unit (2) receives inputs from the occupant classification sensors (1) (located inside the passenger seat cushion assembly). Depending on classification of the passenger, the OCS sends a signal to the air bag diagnosis sensor unit. The air bag diagnosis sensor unit uses this signal and the seat belt buckle switch (passenger seat) signal to determine deployment or non deployment of the passenger front air bag in the event of a collision. Depending on the signals received, the air bag diagnosis sensor unit can disable the passenger front air bag completely. The OCS (weight sensors) must be set to zero point using CONSULT after servicing the OCS system.

NOTE:

- CONSULT can be used to confirm when “zero point reset” for OCS is complete.
- Always perform zero point reset after the removal and installation of the seat or when disconnecting the OCS control unit harness connector even if zero point reset has been completed in the past.
- If zero point reset is incomplete, the passenger air bag will be disabled and the passenger air bag off indicator will be ON.
- In case of customer concern, CONSULT can be used to confirm the passenger air bag status (readiness).

Passenger Air Bag Status Conditions

Front Passenger Seat (Condition)	PASS AIR BAG OFF Indicator (Status)	Passenger Air Bag Status (Readiness)	CONSULT Display
Seat occupied	OFF	Active (enabled)	ON
Seat occupied ^{NOTE}	ON	Deactivated (disabled)	OFF
Seat empty	OFF	Deactivated (disabled)	OFF

NOTE:

SYSTEM

< SYSTEM DESCRIPTION >

Passenger does not meet Occupant Classification System specifications for passenger air bag activation.

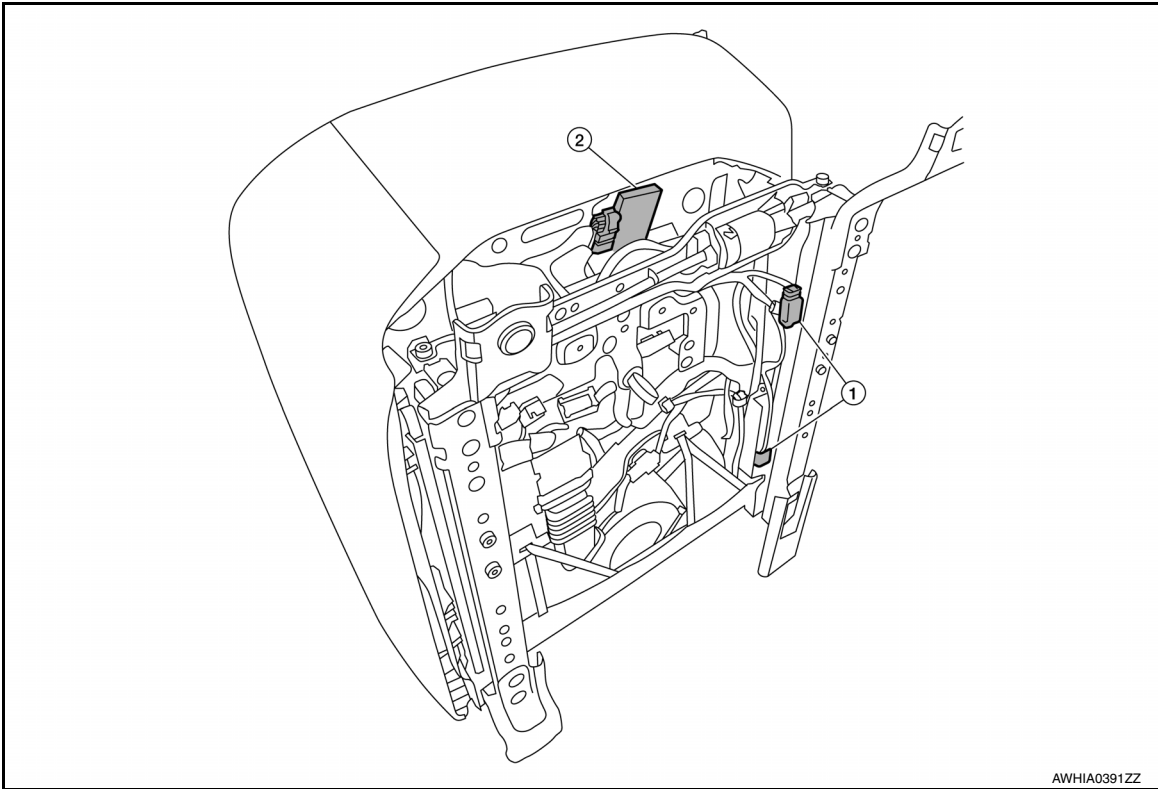

SEAT BELT WARNING LAMP SYSTEM

SEAT BELT WARNING LAMP SYSTEM : System Diagram

INFOID:000000009134368

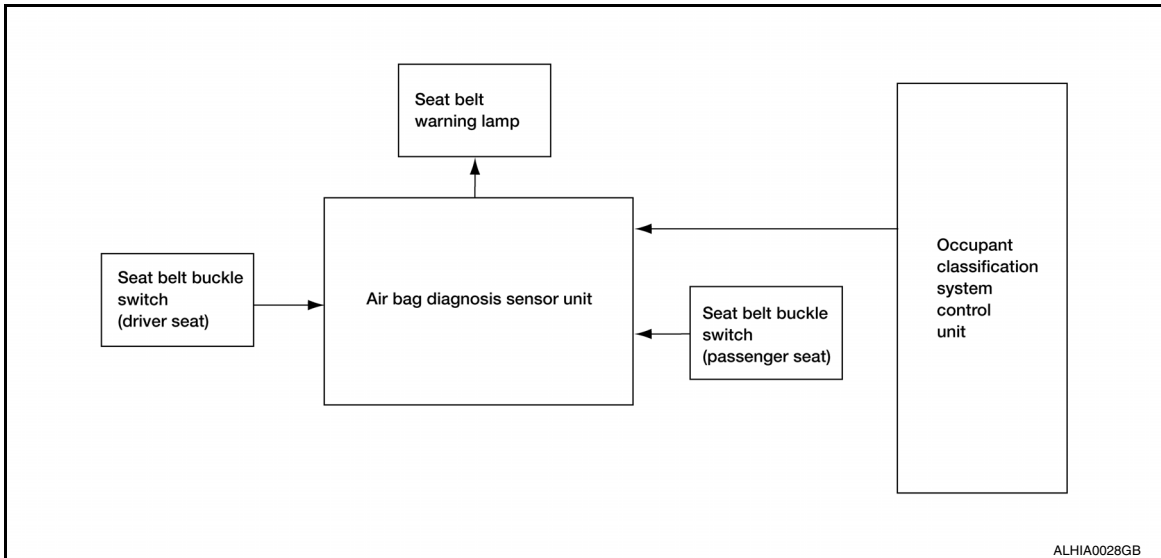

A
B
C
D
E
F
G
H
I
J
K
L
M
N
O
P

SRC

SYSTEM

< SYSTEM DESCRIPTION >

SEAT BELT WARNING LAMP SYSTEM : System Description

INFOID:000000009134369

The seat belt warning lamp (1) will remind the driver if the driver or front passenger seat belt should be buckled. The system works in conjunction with the occupant classification system. Refer to [SRC-12, "OCCUPANT CLASSIFICATION SYSTEM : System Description"](#).

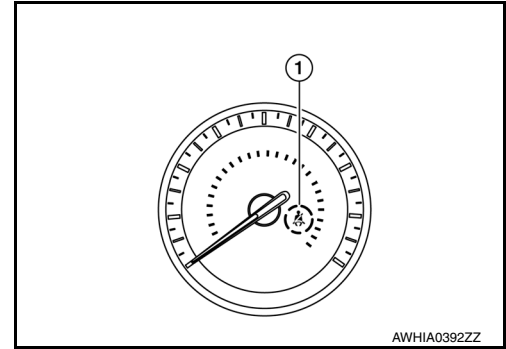

Seat Belt Warning System Operation

Driver seat status (Ignition switch ON)	Passenger seat status	Seat belt buckle switch (driver side) status	Seat belt buckle switch (passenger side) status	Seat belt warning lamp
Seat occupied	Seat occupied	Buckled	Buckled	Off
			Unbuckled	On
	Seat unoccupied	Unbuckled	—	Off
			—	On

DIAGNOSIS SYSTEM (AIR BAG)

< SYSTEM DESCRIPTION >

DIAGNOSIS SYSTEM (AIR BAG)

Diagnosis Description

INFOID:000000009134370

CAUTION:

- Do not use electrical test equipment on any circuit related to the SRS unless instructed to do so in this Service Manual. SRS wiring harnesses can be identified by yellow and/or orange harness connectors.
- Do not attempt to repair, splice or modify SRS wiring harnesses. If a harness is damaged, replace it with a new one.
- Keep ground connections clean.

HOW TO PERFORM TROUBLE DIAGNOSES FOR QUICK AND ACCURATE REPAIR

1. Obtain information about the symptom.
 - WHAT - vehicle model
 - WHEN - date, frequencies
 - WHERE - road conditions
 - HOW - operating conditions, symptoms, passengers
2. Perform Preliminary Check.
 - Battery
 - Fuses
 - Harness connections

DIAGNOSIS METHODS

SRS self-diagnosis results can be read by using the AIR BAG warning lamp or CONSULT.

The User Mode is for the customer (driver). This mode warns the driver of a system malfunction through the AIR BAG warning lamp.

The Diagnosis Mode is for the technician. This mode helps the technician locate the malfunctioning circuit or part.

	User Mode	Diagnosis Mode	Display type
AIR BAG warning lamp	X	X	ON/OFF
CONSULT	—	X	Monitoring

SRS Operation Check

INFOID:000000009134371

USER MODE

1. Turn the ignition switch from OFF to ON and check that the air bag warning lamp blinks.
2. Compare the blinking pattern with the examples in the table.

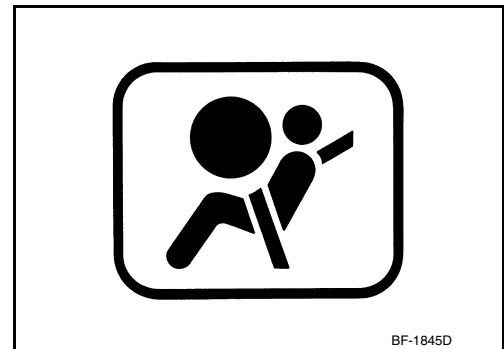

DIAGNOSIS SYSTEM (AIR BAG)

< SYSTEM DESCRIPTION >

Air bag warning lamp flashing pattern (User Mode)

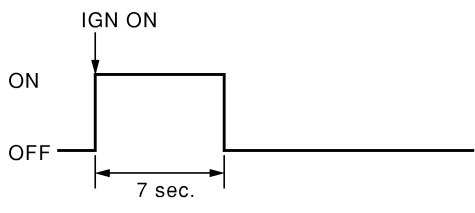
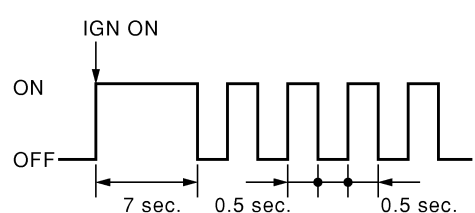
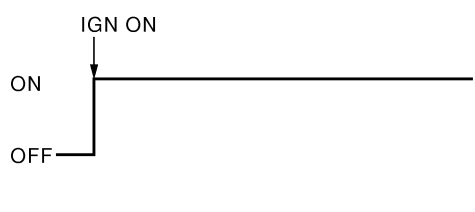
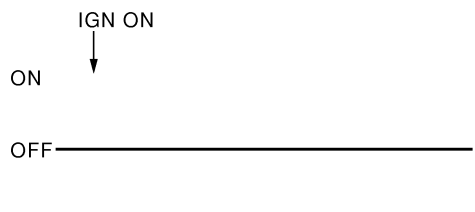
Warning lamp	SRS condition	Reference item
 <p>SHIA0011E</p>	<ul style="list-style-type: none"> No malfunction is detected. No further action is necessary. 	—
 <p>SHIA0012E</p>	<p>The system is malfunctioning and needs to be repaired.</p> <p>Zero point reset is incomplete</p>	<p>Refer to SRC-16, "Trouble Diagnosis with CONSULT" or SRC-17, "Trouble Diagnosis without CONSULT".</p> <p>Refer to SRC-42, "ZERO POINT RESET : Special Repair Requirement".</p>
 <p>SHIA0013E</p>	<ul style="list-style-type: none"> Air bag is deployed. Seat belt pre-tensioner is deployed. Air bag diagnosis sensor unit is malfunctioning. Air bag power supply circuit is malfunctioning. SRS air bag warning lamp circuit is malfunctioning. 	<p>Refer to SR-5, "For Frontal Collision" or SR-7, "For Side and Rollover Collision".</p> <p>Refer to SRC-107, "AIR BAG Warning Lamp Does Not Turn Off".</p>
 <p>SHIA0014E</p>	<ul style="list-style-type: none"> Air bag diagnosis sensor unit is malfunctioning. Air bag warning lamp circuit is malfunctioning. 	<p>Refer to SRC-106, "AIR BAG Warning Lamp Does Not Turn On".</p>

Trouble Diagnosis with CONSULT

INFOID:000000009134372

1. Connect CONSULT.
2. DTC is displayed on SELF-DIAG RESULTS.

NOTE:

If a malfunction is not detected on SELF-DIAG RESULTS [CURRENT], but a malfunction is detected during SRS Operation Check, the following cases may exist:

- SELF-DIAG [PAST] memory might not be erased. Refer to [SRC-17, "SRS Final Check"](#).
- SRS system malfunctions intermittently. Refer to [SRC-43, "Inspection Procedure"](#).

DIAGNOSIS SYSTEM (AIR BAG)

< SYSTEM DESCRIPTION >

Trouble Diagnosis without CONSULT

INFOID:000000009134373

DIAGNOSIS MODE

NOTE:

Diagnosis Mode can not be entered if a malfunction is not detected in User Mode.

1. Turn ignition switch ON.
2. After AIR BAG warning lamp lights for 7 seconds, turn ignition switch OFF within 1 second.

NOTE:

When in Diagnosis Mode, the air bag warning lamp may illuminate for more than 7 seconds after the ignition switch is turned ON. If this is the case, the ignition switch must still be cycled OFF after 7 seconds.

3. Wait more than 3 seconds.
4. Repeat steps 1 to 3 two more times (3 times total).
5. Turn ignition switch ON.

SRS is now in Diagnosis Mode. Refer to [SRC-23, "Flash Code Index"](#).

SRS History Check

INFOID:000000009134374

SRS HISTORY CHECK

1. Check repair history of the SRS. If no repairs have been made, perform [SRC-15, "SRS Operation Check"](#). If repairs have been made, GO TO step 2.
2. Erase "SELF-DIAG [PAST]" after repair. Refer to [SRC-17, "SRS Final Check"](#).

SRS Final Check

INFOID:000000009134375

DIAGNOSIS MODE

1. Connect CONSULT.
2. Confirm that zero point reset of OCS is complete.
3. If no DTCs are detected on "SELF-DIAG RESULTS [CURRENT]", repair of SRS is completed. Go to step 4.
If any DTCs are detected on "SELF-DIAG RESULTS [CURRENT]", the malfunction has not been repaired completely or another malfunction is being detected. Perform SRS Operation Check again. Refer to [SRC-15, "SRS Operation Check"](#).
4. Touch "ERASE".
NOTE:
Touching "ERASE" will clear the SRS memory of the malfunction ("SELF-DIAG [PAST]"). If "SELF-DIAG [PAST]" is not erased, User Mode may show the previous system malfunction even if the malfunction has been repaired completely.
5. Check that no malfunction is detected in "SELF-DIAG [PAST]".
6. Exit Diagnosis Mode and disconnect the CONSULT.
7. Perform SRS Operation Check. Refer to [SRC-15, "SRS Operation Check"](#).

CONSULT Function (AIR BAG)

INFOID:000000009134376

CAUTION:

After disconnecting the CONSULT vehicle interface (VI) from the data link connector, the ignition must be cycled OFF → ON (for at least 5 seconds) → OFF. If this step is not performed, the BCM may not go to "sleep mode", potentially causing a discharged battery and no-start condition.

APPLICATION ITEMS

CONSULT can display each diagnostic item using the diagnostic test modes shown following.

Diagnostic Test Mode	Diagnostic Item	Description
Self Diagnostic Result	SELF-DIAG RESULT [CURRENT]	A current Self-diagnosis result (also indicated by the number of warning lamp flashes in the Diagnosis mode) is displayed on the CONSULT screen in real time. This refers to a malfunctioning part requiring repairs.
Data Monitor	DATA MONITOR	Displays air bag diagnosis sensor unit input/output data in real time.

DIAGNOSIS SYSTEM (AIR BAG)

< SYSTEM DESCRIPTION >

Diagnostic Test Mode	Diagnostic Item	Description
Ecu Identification	ECU DISCRIMINATED NO.	Air bag diagnosis sensor unit ECU discriminated number (identification number) or part number is displayed. Air bag diagnosis sensor unit has individual ECU discriminated number (identification number) or part number based on model and equipment.
Trouble Diagnostic Record	TROUBLE DIAG RECORD [PAST]	With TROUBLE DIAG RECORD, diagnosis results previously erased by a reset operation can be displayed on the CONSULT screen.

CONSULT Function (OCCUPANT DETECTION)

INFOID:000000009134377

CONSULT can display each diagnostic item using the diagnostic test modes shown following.

Diagnostic Test Mode	Diagnostic Item	Description
Work Support	ZERO POINT RESET FUNCTION	Perform zero point reset. Refer to SRC-42, "ZERO POINT RESET : Special Repair Requirement" .

DIAGNOSIS SENSOR UNIT

< ECU DIAGNOSIS INFORMATION >

ECU DIAGNOSIS INFORMATION

DIAGNOSIS SENSOR UNIT

DTC Index

INFOID:000000009764444

DIAGNOSTIC CODE CHART

NOTE:

Follow the procedures in numerical order when repairing malfunctioning parts. Confirm whether malfunction is eliminated using air bag warning lamp or CONSULT each time repair is finished. If malfunction is still observed, proceed to the next step. When malfunction is eliminated, further repair work is not required.

CONSULT name	DTC	DTC detecting condition	Repair order
CAN COMMUNICATION FAILURE	U1000	CAN system communication failure.	Refer to SRC-44. "Diagnosis Procedure" .
CAN COMMUNICATION FAILURE [CONTROL UNIT]	U1010	CAN system (control unit) failure.	Refer to SRC-45. "Diagnosis Procedure" .
DRIVER AIRBAG MODULE CIRCUIT [OPEN]	B0001	Driver air bag module circuit (DR1) is open (including the spiral cable).	Refer to SRC-47. "Diagnosis Procedure" .
DRIVER AIRBAG MODULE CIRCUIT [VB-SHORT]		Driver air bag module circuit (DR1) is shorted to a power supply circuit (including the spiral cable).	
DRIVER AIRBAG MODULE CIRCUIT [GND-SHORT]		Driver air bag module circuit (DR1) is shorted to ground (including the spiral cable).	
DRIVER AIRBAG MODULE CIRCUIT [SHORT]		Driver air bag module circuits (DR1) are shorted to each other (including the spiral cable).	
DRIVER AIRBAG MODULE 2ND CIRCUIT [OPEN]	B0002	Driver air bag module circuit (DR2) is open (including the spiral cable).	
DRIVER AIRBAG MODULE 2ND CIRCUIT [VB-SHORT]		Driver air bag module circuit (DR2) is shorted to a power supply circuit (including the spiral cable).	
DRIVER AIRBAG MODULE 2ND CIRCUIT [GND-SHORT]		Driver air bag module circuit (DR2) is shorted to ground (including the spiral cable).	
DRIVER AIRBAG MODULE 2ND CIRCUIT [SHORT]		Driver air bag module circuits (DR2) are shorted to each other (including the spiral cable).	
ASSIST AIRBAG MODULE CIRCUIT [OPEN]	B0010	Front passenger air bag module circuit (AS1) is open.	Refer to SRC-50. "Diagnosis Procedure" .
ASSIST AIRBAG MODULE CIRCUIT [VB-SHORT]		Front passenger air bag module circuit (AS1) is shorted to a power supply circuit.	
ASSIST AIRBAG MODULE CIRCUIT [GND-SHORT]		Front passenger air bag module circuit (AS1) is shorted to ground.	
ASSIST AIRBAG MODULE CIRCUIT [SHORT]		Front passenger air bag module circuits (AS1) are shorted to each other.	
ASSIST AIRBAG MODULE 2ND CIRCUIT [OPEN]	B0011	Front passenger air bag module circuit (AS2) is open.	
ASSIST AIRBAG MODULE 2ND CIRCUIT [VB-SHORT]		Front passenger air bag module circuit (AS2) is shorted to a power supply circuit.	
ASSIST AIRBAG MODULE 2ND CIRCUIT [GND-SHORT]		Front passenger air bag module circuit (AS2) is shorted to ground.	
ASSIST AIRBAG MODULE 2ND CIRCUIT [SHORT]		Front passenger air bag module circuits (AS2) are shorted to each other.	

A
B
C
D
E
F
G
I
J
K
L
M
N
O
P



DIAGNOSIS SENSOR UNIT

< ECU DIAGNOSIS INFORMATION >

CONSULT name	DTC	DTC detecting condition	Repair order
SIDE AIRBAG MODULE LH CIRCUIT [OPEN]	B0020	Front LH side air bag module circuit is open.	Refer to SRC-52 . "Diagnosis Procedure".
SIDE AIRBAG MODULE LH CIRCUIT [VB-SHORT]		Front LH side air bag module circuit is shorted to a power supply circuit.	
SIDE AIRBAG MODULE LH CIRCUIT [GND-SHORT]		Front LH side air bag module circuit is shorted to ground.	
SIDE AIRBAG MODULE LH CIRCUIT [SHORT]		Front LH side air bag module circuits are shorted to each other.	
SIDE AIRBAG MODULE RH CIRCUIT [OPEN]	B0028	Front RH side air bag module circuit is open.	Refer to SRC-54 . "Diagnosis Procedure".
SIDE AIRBAG MODULE RH CIRCUIT [VB-SHORT]		Front RH side air bag module circuit is shorted to a power supply circuit.	
SIDE AIRBAG MODULE RH CIRCUIT [GND-SHORT]		Front RH side air bag module circuit is shorted to ground.	
SIDE AIRBAG MODULE RH CIRCUIT [SHORT]		Front RH side air bag module circuits are shorted to each other.	
CURTAIN AIRBAG MODULE LH CIRCUIT [OPEN]	B0021	LH side curtain air bag module circuit is open.	Refer to SRC-56 . "Diagnosis Procedure".
CURTAIN AIRBAG MODULE LH CIRCUIT [VB-SHORT]		LH side curtain air bag module circuit is shorted to a power supply circuit.	
CURTAIN AIRBAG MODULE LH CIRCUIT [GND-SHORT]		LH side curtain air bag module circuit is shorted to ground.	
CURTAIN AIRBAG MODULE LH CIRCUIT [SHORT]		LH side curtain air bag module circuits are shorted to each other.	
CURTAIN AIRBAG MODULE RH CIRCUIT [OPEN]	B0029	RH side curtain air bag module circuit is open.	Refer to SRC-58 . "Diagnosis Procedure".
CURTAIN AIRBAG MODULE RH CIRCUIT [VB-SHORT]		RH side curtain air bag module circuit is shorted to a power supply circuit.	
CURTAIN AIRBAG MODULE RH CIRCUIT [GND-SHORT]		RH side curtain air bag module circuit is shorted to ground.	
CURTAIN AIRBAG MODULE RH CIRCUIT [SHORT]		RH side curtain air bag module circuits are shorted to each other.	
CRASH ZONE SENSOR [SENSOR FAIL]	B0094	Crash zone sensor has malfunctioned.	Refer to SRC-61 . "Diagnosis Procedure".
CRASH ZONE SENSOR [COMM FAIL]		Crash zone sensor communication error.	
CRASH ZONE SENSOR [DISCONNECT]		Crash zone sensor is disconnected.	
CRASH ZONE SENSOR [UNMATCH]		Crash zone sensor is out of specification.	
CRASH ZONE SENSOR [GND-SHORT]		Crash zone sensor circuit is shorted to ground.	
B-PILLAR SATELLITE SENSOR LH [SENSOR FAIL]	B0091	Front side air bag satellite sensor LH has malfunctioned.	Refer to SRC-64 . "Diagnosis Procedure".
B-PILLAR SATELLITE SENSOR LH [COMM FAIL]		Front side air bag satellite sensor LH communication error.	
B-PILLAR SATELLITE SENSOR LH [DISCONNECT]		Front side air bag satellite sensor LH is disconnected.	
B-PILLAR SATELLITE SENSOR LH [UNMATCH]		Front side air bag satellite sensor LH is out of specification.	
B-PILLAR SATELLITE SENSOR LH [GND-SHORT]		Front side air bag satellite sensor LH circuit is shorted to ground.	

DIAGNOSIS SENSOR UNIT

< ECU DIAGNOSIS INFORMATION >

CONSULT name	DTC	DTC detecting condition	Repair order	
B-PILLAR SATELLITE SENSOR RH [SENSOR FAIL]	B0096	Front side air bag satellite sensor RH has malfunctioned.	Refer to SRC-67 , "Diagnosis Procedure".	A
B-PILLAR SATELLITE SENSOR RH [COMM FAIL]		Front side air bag satellite sensor RH communication error.		B
B-PILLAR SATELLITE SENSOR RH [DISCONNECT]		Front side air bag satellite sensor RH is disconnected.		C
B-PILLAR SATELLITE SENSOR RH [UNMATCH]		Front side air bag satellite sensor RH is out of specification.		D
B-PILLAR SATELLITE SENSOR RH [GND-SHORT]		Front side air bag satellite sensor RH circuit is shorted to ground.		
C-PILLAR SATELLITE SENSOR LH [SENSOR FAIL]	B0092	Rear side air bag satellite sensor LH has malfunctioned.	Refer to SRC-69 , "Diagnosis Procedure".	E
C-PILLAR SATELLITE SENSOR LH [COMM FAIL]		Rear side air bag satellite sensor LH communication error.		F
C-PILLAR SATELLITE SENSOR LH [DISCONNECT]		Rear side air bag satellite sensor LH is disconnected.		G
C-PILLAR SATELLITE SENSOR LH [UNMATCH]		Rear side air bag satellite sensor LH is out of specification.		
C-PILLAR SATELLITE SENSOR LH [GND-SHORT]		Rear side air bag satellite sensor LH circuit is shorted to ground.		
C-PILLAR SATELLITE SENSOR RH [SENSOR FAIL]	B0097	Rear side air bag satellite sensor RH has malfunctioned.	Refer to SRC-73 , "Diagnosis Procedure".	SRC
C-PILLAR SATELLITE SENSOR RH [COMM FAIL]		Rear side air bag satellite sensor RH communication error.		I
C-PILLAR SATELLITE SENSOR RH [DISCONNECT]		Rear side air bag satellite sensor RH is disconnected.		J
C-PILLAR SATELLITE SENSOR RH [UNMATCH]		Rear side air bag satellite sensor RH is out of specification.		
C-PILLAR SATELLITE SENSOR RH [GND-SHORT]		Rear side air bag satellite sensor RH circuit is shorted to ground.		
DOOR SATELLITE SENSOR LH [SENSOR FAIL]	B0093	Front door satellite sensor LH has malfunctioned.	Refer to SRC-75 , "Diagnosis Procedure".	K
DOOR SATELLITE SENSOR LH [COMM FAIL]		Front door satellite sensor LH communication error.		L
DOOR SATELLITE SENSOR LH [DISCONNECT]		Front door satellite sensor LH is disconnected.		M
DOOR SATELLITE SENSOR LH [UNMATCH]		Front door satellite sensor LH is out of specification.		
DOOR SATELLITE SENSOR LH [GND-SHORT]		Front door satellite sensor LH circuit is shorted to ground.		
DOOR SATELLITE SENSOR RH [SENSOR FAIL]	B0098	Front door satellite sensor RH has malfunctioned.	Refer to SRC-78 , "Diagnosis Procedure".	N
DOOR SATELLITE SENSOR RH [COMM FAIL]		Front door satellite sensor RH communication error.		O
DOOR SATELLITE SENSOR RH [DISCONNECT]		Front door satellite sensor RH is disconnected.		P
DOOR SATELLITE SENSOR RH [UNMATCH]		Front door satellite sensor RH is out of specification.		
DOOR SATELLITE SENSOR RH [GND-SHORT]		Front door satellite sensor RH circuit is shorted to ground.		

DIAGNOSIS SENSOR UNIT

< ECU DIAGNOSIS INFORMATION >

CONSULT name	DTC	DTC detecting condition	Repair order
OCCUPANT DETECTION SENSOR UNIT [UNIT FAIL]	B00A0	The OCS control unit is malfunctioning.	Refer to SRC-82, "Diagnosis Procedure" .
OCCUPANT DETECTION SENSOR UNIT [NO DATA]			
OCCUPANT DETECTION SENSOR UNIT [UNDEFINED]			
OCCUPANT DETECTION SENSOR UNIT [RESET FAIL]			
OCCUPANT DETECTION SENSOR UNIT [COMM FAIL]		Communication between the OCS control unit and the air bag diagnosis sensor unit is interrupted.	
OCCUPANT DETECTION SENSOR [UNIT FAIL]		The OCS sensor is malfunctioning.	
OCCUPANT DETECTION SENSOR [POWER FAIL]		The OCS sensor circuit is malfunctioning.	
PASSENGER AIRBAG INDICATOR CIRCUIT [FAIL]	B00D5	Front passenger air bag OFF indicator is malfunctioning.	Refer to SRC-84, "Diagnosis Procedure" .
PASSENGER AIRBAG INDICATOR CIRCUIT [OPEN]		Front passenger air bag OFF indicator circuit is open.	
PASSENGER AIRBAG INDICATOR CIRCUIT [VB-SHORT]		Front passenger air bag OFF indicator is shorted to a power supply circuit.	
PASSENGER AIRBAG INDICATOR CIRCUIT [GND-SHORT]		Front passenger air bag OFF indicator is shorted to ground.	
SEAT BELT BUCKLE SW LH CIRCUIT [OPEN]	B1428	LH seat belt buckle switch circuit is open.	Refer to SRC-87, "Diagnosis Procedure" .
SEAT BELT BUCKLE SW LH CIRCUIT [VB-SHORT]		LH seat belt buckle switch circuit is shorted to a power supply circuit.	
SEAT BELT BUCKLE SW LH CIRCUIT [GND-SHORT]		LH seat belt buckle switch circuit is shorted to ground.	
SEAT BELT BUCKLE SW LH CIRCUIT [UNDEFINED]		LH seat belt buckle switch circuit malfunction.	
SEAT BELT BUCKLE SW RH CIRCUIT [OPEN]	B1429	RH seat belt buckle switch circuit is open.	Refer to SRC-89, "Diagnosis Procedure" .
SEAT BELT BUCKLE SW RH CIRCUIT [VB-SHORT]		RH seat belt buckle switch circuit is shorted to a power supply circuit.	
SEAT BELT BUCKLE SW RH CIRCUIT [GND-SHORT]		RH seat belt buckle switch circuit is shorted to ground.	
SEAT BELT BUCKLE SW RH CIRCUIT [UNDEFINED]		RH seat belt buckle switch circuit malfunction.	
FRONT PRE-TEN LH CIRCUIT [OPEN]	B1430	LH seat belt pre-tensioner circuit is open.	Refer to SRC-91, "Diagnosis Procedure" .
FRONT PRE-TEN LH CIRCUIT [VB-SHORT]		LH seat belt pre-tensioner circuit is shorted to a power supply circuit.	
FRONT PRE-TEN LH CIRCUIT [GND-SHORT]		LH seat belt pre-tensioner circuit is shorted to ground.	
FRONT PRE-TEN LH CIRCUIT [SHORT]		LH seat belt pre-tensioner circuits are shorted to each other.	

DIAGNOSIS SENSOR UNIT

< ECU DIAGNOSIS INFORMATION >

CONSULT name	DTC	DTC detecting condition	Repair order
FRONT PRE-TEN RH CIRCUIT [OPEN]	B1431	RH seat belt pre-tensioner circuit is open.	Refer to SRC-93. "Diagnosis Procedure" .
FRONT PRE-TEN RH CIRCUIT [VB-SHORT]		RH seat belt pre-tensioner circuit is shorted to a power supply circuit.	
FRONT PRE-TEN RH CIRCUIT [GND-SHORT]		RH seat belt pre-tensioner circuit is shorted to ground.	
FRONT PRE-TEN RH CIRCUIT [SHORT]		RH seat belt pre-tensioner circuits are shorted to each other.	
FRONT PRE-TEN2 LH CIRCUIT [OPEN]	B1432	LH lap pre-tensioner circuit is open.	Refer to SRC-95. "Diagnosis Procedure" .
FRONT PRE-TEN2 LH CIRCUIT [VB-SHORT]		LH lap pre-tensioner circuit is shorted to a power supply circuit.	
FRONT PRE-TEN2 LH CIRCUIT [GND-SHORT]		LH lap pre-tensioner circuit is shorted to ground.	
FRONT PRE-TEN2 LH CIRCUIT [SHORT]		LH lap pre-tensioner circuits are shorted to each other.	
FRONT PRE-TEN2 RH CIRCUIT [OPEN]	B1433	RH lap pre-tensioner circuit is open.	Refer to SRC-97. "Diagnosis Procedure" .
FRONT PRE-TEN2 RH CIRCUIT [VB-SHORT]		RH lap pre-tensioner circuit is shorted to a power supply circuit.	
FRONT PRE-TEN2 RH CIRCUIT [GND-SHORT]		RH lap pre-tensioner circuit is shorted to ground.	
FRONT PRE-TEN2 RH CIRCUIT [SHORT]		RH lap pre-tensioner circuits are shorted to each other.	
ACTIVE VENT CIRCUIT [OPEN]	B1436	Active vent circuit is open.	Refer to SRC-99. "Diagnosis Procedure" .
ACTIVE VENT CIRCUIT [VB-SHORT]		Active vent circuit is shorted to a power supply circuit.	
ACTIVE VENT CIRCUIT [GND-SHORT]		Active vent circuit is shorted to ground.	
ACTIVE VENT CIRCUIT [SHORT]		Active vent circuits are shorted to each other.	
IGN VOLTAGE [LOW]	B142A	Ignition voltage to the air bag diagnosis sensor unit is low.	Refer to SRC-101. "Diagnosis Procedure" .
IGN VOLTAGE [HIGH]		Ignition voltage to the air bag diagnosis sensor unit is high.	
FRONTAL COLLISION DETECTION	B1421	Frontal collision detected. Driver and/or front passenger air bag modules are deployed.	Refer to SR-5. "For Frontal Collision" .
SIDE COLLISION DETECTION	B1422	Side collision detected. Curtain air bag module and seat belt pre-tensioner are deployed.	Refer to SR-7. "For Side and Rollover Collision" .
CONTROL UNIT [UNIT FAIL]	B14XX	Air bag diagnosis sensor unit is malfunctioning.	Refer to SRC-104. "Diagnosis Procedure" .

Flash Code Index

INFOID:000000009764445

WARNING LAMP FLASH CODE CHART

How to read flash codes

1. Put the vehicle in Diagnosis Mode. Refer to [SRC-17. "Trouble Diagnosis without CONSULT"](#).
2. All codes are preceded by a seven second "holding" flash.
3. Identify how many primary flashes are displayed as well as the length of each primary flash.
4. Refer to the tables and examples below to determine which SRS subsystem the code belongs to.

A
B
C
D
E
F
G
I
J
K
L
M
N
O
P

SRC

DIAGNOSIS SENSOR UNIT

< ECU DIAGNOSIS INFORMATION >

5. Count the short secondary flashes that follow the primary flashes.
6. Match the correct flashing pattern to the malfunctioning component and perform the Diagnosis Procedure.

Refer to the illustrations below for an example of each flashing pattern.

Front subsystem

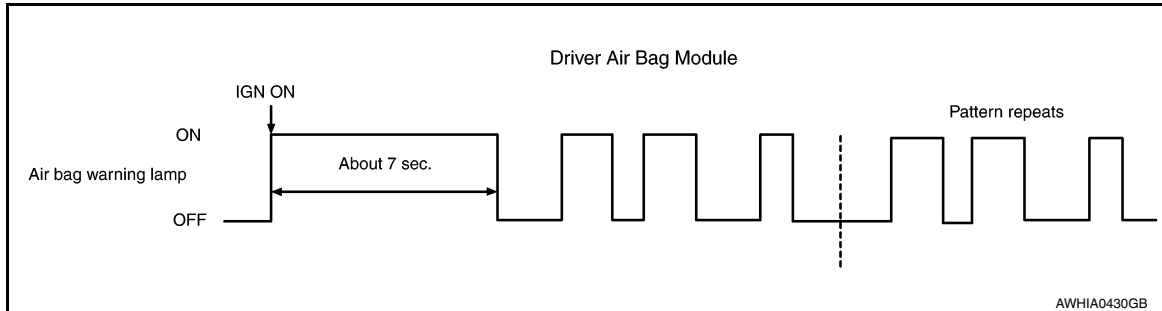

Flashes (Primary)	Flash Length (seconds)	Flashes (Secondary)	Malfunctioning Component or Circuit	Reference
2	1.5	1	Driver air bag module	SRC-47. "Diagnosis Procedure"
		2	Passenger air bag module	SRC-50. "Diagnosis Procedure"
		3	Front LH seat belt pre-tensioner	SRC-91. "Diagnosis Procedure"
		4	Front RH seat belt pre-tensioner	SRC-93. "Diagnosis Procedure"
		5	Front LH lap pre-tensioner	SRC-95. "Diagnosis Procedure"
		6	Front RH lap pre-tensioner	SRC-97. "Diagnosis Procedure"

Side subsystem

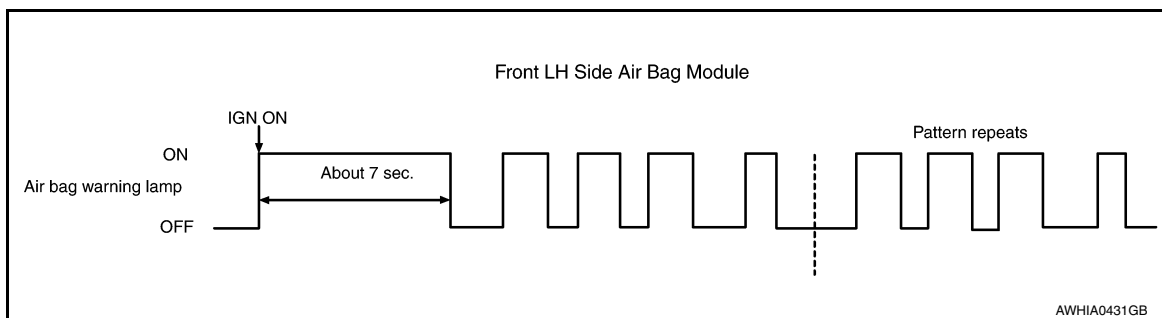

Flashes (Primary)	Flash Length (seconds)	Flashes (Secondary)	Malfunctioning Component or Circuit	Reference
3	1.5	1	Front LH side air bag module	SRC-52. "Diagnosis Procedure"
		2	Front RH side air bag module	SRC-54. "Diagnosis Procedure"
		3	LH side curtain air bag module	SRC-56. "Diagnosis Procedure"
		4	RH side curtain air bag module	SRC-58. "Diagnosis Procedure"

Air bag subsystem

DIAGNOSIS SENSOR UNIT

< ECU DIAGNOSIS INFORMATION >

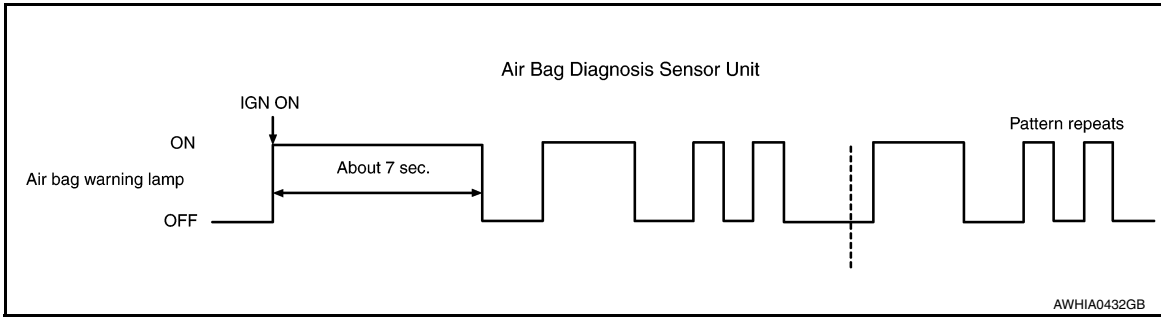

Flashes (Primary)	Flash Length (seconds)	Flashes (Secondary)	Malfunctioning Component or Circuit	Reference
1	3	1	Collision detection	SRC-103. "Diagnosis Procedure"
		2	Air bag diagnosis sensor unit	SRC-104. "Diagnosis Procedure"
		3	Passenger air bag OFF indicator	SRC-84. "Diagnosis Procedure"
		4	Occupant classification system	SRC-82. "Diagnosis Procedure"

Sensor subsystem

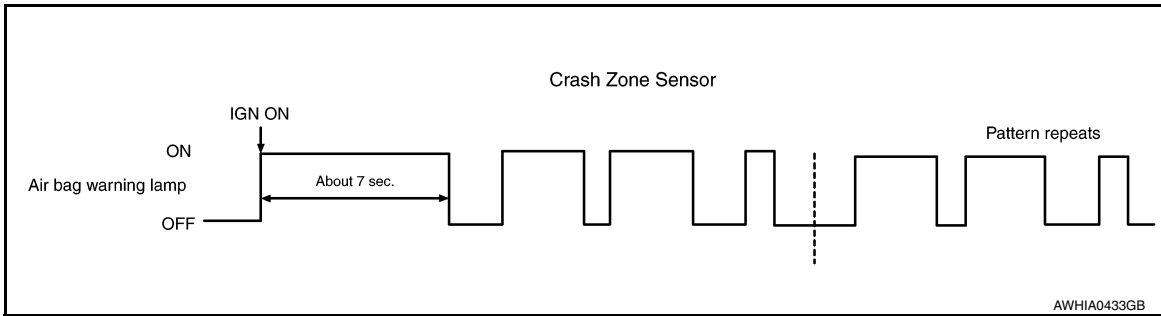

Flashes (Primary)	Flash Length (seconds)	Flashes (Secondary)	Malfunctioning Component or Circuit	Reference
2	3	1	Crash zone sensor	SRC-61. "Diagnosis Procedure"
		2	Front side air bag satellite sensor LH	SRC-64. "Diagnosis Procedure"
		3	Front side air bag satellite sensor RH	SRC-67. "Diagnosis Procedure"
		4	Rear side air bag satellite sensor LH	SRC-69. "Diagnosis Procedure"
		5	Rear side air bag satellite sensor RH	SRC-73. "Diagnosis Procedure"
		6	Front door satellite sensor LH	SRC-75. "Diagnosis Procedure"
		7	Front door satellite sensor RH	SRC-78. "Diagnosis Procedure"
		8	Seat belt buckle switch LH	SRC-87. "Diagnosis Procedure"
		9	Seat belt buckle switch RH	SRC-89. "Diagnosis Procedure"

A
B
C
D
E
F
G
I
J
K
L
M
N
O
P

SRC

SRS AIR BAG SYSTEM

< WIRING DIAGRAM >

SRS AIR BAG CONTROL SYSTEM CONNECTORS

Connector No.	M4
Connector Name	FUSE BLOCK (J/B)
Connector Color	WHITE



Terminal No.	Color of Wire	Signal Name
1P	R	-
8P	BG	-
13P	W	-

Connector No.	M22
Connector Name	DATA LINK CONNECTOR
Connector Color	WHITE

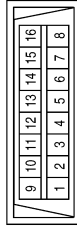

Terminal No.	Color of Wire	Signal Name
7	R	-

Connector No.	M24
Connector Name	COMBINATION METER
Connector Color	WHITE

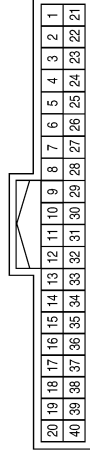

Terminal No.	Color of Wire	Signal Name
1	B	GND 1
2	B	GND 2
7	R	AIR BAG
8	G	AS BELT
9	Y	DR BUCKLE SW
21	BG	IGN
22	W	BAT

Connector No.	M26
Connector Name	FRONT PASSENGER AIR BAG MODULE
Connector Color	YELLOW



Terminal No.	Color of Wire	Signal Name
5	W	-
6	BG	-

Connector No.	M31
Connector Name	WIRE TO WIRE
Connector Color	WHITE

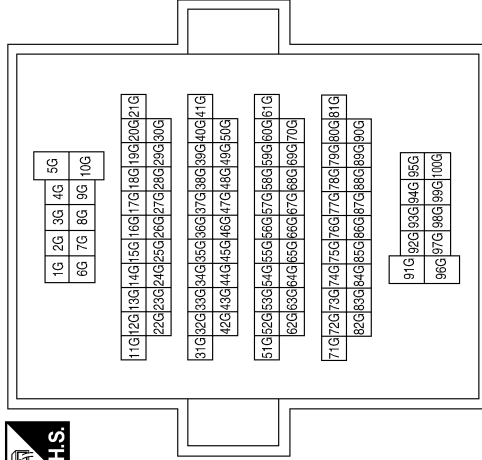

Terminal No.	Color of Wire	Signal Name
59G	B	-
60G	W	-
61G	SHIELD	-

ABHIA0654GB

SRS AIR BAG SYSTEM

< WIRING DIAGRAM >

Connector No.	M35
Connector Name	AIR BAG DIAGNOSIS SENSOR UNIT
Connector Color	YELLOW

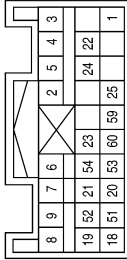

Terminal No.	Color of Wire	Signal Name
1	R	IGN
2	B	GND
3	LG	DR1+
4	Y	DR1+, DR2-



Connector No.	M39
Connector Name	JOINT CONNECTOR-M06
Connector Color	WHITE

Terminal No.	Color of Wire	Signal Name
5	BR	DR2+
6	W	AS1+
7	G	AS1-
8	W	AS2+
9	G	AS2-
18	B	ECZS 1+
19	W	ECZS 1-
20	W	ACT VENT+
21	BG	ACT VENT-
22	V	GND (FOR SHIELD WIRE GND) (EXCEPT MEXICO)
22	SHIELD	GND (FOR SHIELD WIRE GND) (FOR MEXICO)

Terminal No.	Color of Wire	Signal Name
23	R	AIRBAG W/L
24	G	SEATBELT REMINDER
25	R	CUTOFF TELLTALE
51	B	RH DOOR SATELLITE SENSOR +
52	W	RH DOOR SATELLITE SENSOR -
53	B	LH DOOR SATELLITE SENSOR +
54	W	LH DOOR SATELLITE SENSOR -
59	L	CAN-H
60	P	CAN-L

Connector No.	M40
Connector Name	WIRE TO WIRE
Connector Color	GRAY

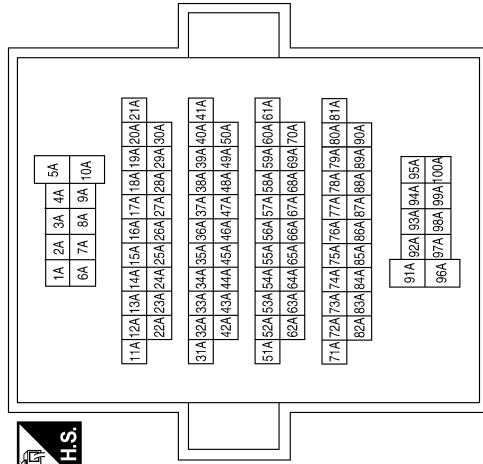

Terminal No.	Color of Wire	Signal Name
31A	R	-
67A	Y	-

A
B
C
D
E
F
G
H
I
J
K
L
M
N
O
P

SRC

ABHIA0655GB

SRS AIR BAG SYSTEM

< WIRING DIAGRAM >

Connector No.	M77
Connector Name	FRONT PASSENGER AIR BAG MODULE (SERVICE REPLACEMENT)
Connector Color	YELLOW

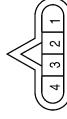

Terminal No.	Color of Wire	Signal Name
1	W	-
2	G	-
3	W	-
4	G	-

Connector No.	M53
Connector Name	COMBINATION SWITCH (SPIRAL CABLE)
Connector Color	YELLOW



Terminal No.	Color of Wire	Signal Name
28	LG	-
29	BR	-
30	Y	-

Connector No.	M49
Connector Name	JOINT CONNECTOR-M15
Connector Color	BLACK

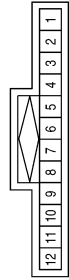

Terminal No.	Color of Wire	Signal Name
1	G	-
2	G	-
3	G	-
4	W	-
5	W	-
6	W	-
7	G	-
8	G	-
9	G	-
10	W	-
11	W	-
12	W	-

Connector No.	M89
Connector Name	DRIVER AIR BAG MODULE
Connector Color	ORANGE



Terminal No.	Color of Wire	Signal Name
9	R	-
12	G	-

Connector No.	M87
Connector Name	DRIVER AIR BAG MODULE
Connector Color	YELLOW



Terminal No.	Color of Wire	Signal Name
10	Y	-
11	L	-

Connector No.	M84
Connector Name	WIRE TO WIRE
Connector Color	WHITE

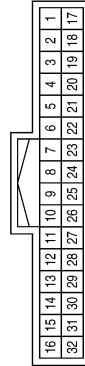

Terminal No.	Color of Wire	Signal Name
19	R	-

ABHIA0656GB

SRS AIR BAG SYSTEM

< WIRING DIAGRAM >

Connector No.	M106
Connector Name	FRONT PASSENGER AIR BAG MODULE
Connector Color	ORANGE



Terminal No.	Color of Wire	Signal Name
3	W	-
4	G	-

Connector No.	M105
Connector Name	FRONT PASSENGER AIR BAG MODULE
Connector Color	YELLOW



Terminal No.	Color of Wire	Signal Name
1	W	-
2	G	-

Connector No.	M98
Connector Name	A/C AND AV SWITCH ASSEMBLY
Connector Color	WHITE

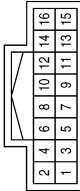

Terminal No.	Color of Wire	Signal Name
1	GR	-
15	R	-

Connector No.	E29
Connector Name	WIRE TO WIRE
Connector Color	YELLOW



Terminal No.	Color of Wire	Signal Name
2	SHIELD	-
3	B	-
4	W	-

Connector No.	M169
Connector Name	WIRE TO WIRE
Connector Color	YELLOW



Terminal No.	Color of Wire	Signal Name
1	W	-
2	SHIELD	-
3	B	-

Connector No.	M159
Connector Name	WIRE TO WIRE
Connector Color	YELLOW



Terminal No.	Color of Wire	Signal Name
1	W	-
2	SHIELD	-
3	B	-

ABHIA0657GB

A
B
C
D
E
F
G
SRC
I
J
K
L
M
N
O
P

SRS AIR BAG SYSTEM

< WIRING DIAGRAM >

Connector No.	E210
Connector Name	WIRE TO WIRE
Connector Color	YELLOW

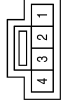

Terminal No.	Color of Wire	Signal Name
2	SHIELD	-
3	L	-
4	R	-

Terminal No.	Color of Wire	Signal Name
59G	W	-
60G	B	-
61G	SHIELD	-

Connector No.	E152
Connector Name	WIRE TO WIRE
Connector Color	WHITE

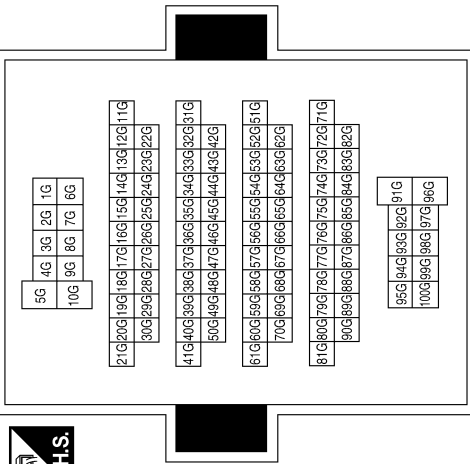

Terminal No.	Color of Wire	Signal Name
29	LG	LH SEAT BELT BUCKLE SWITCH +
31	Y	S-LH+
32	BR	S-LH-
35	B	C-LH1+
36	W	C-LH1-
47	W	LH B-PILLAR SATELLITE SENSOR +
48	B	LH B-PILLAR SATELLITE SENSOR -
55	SHIELD	GND
61	W	LH C-PILLAR SATELLITE SENSOR +
62	B	LH C-PILLAR SATELLITE SENSOR -

Connector No.	B9
Connector Name	AIR BAG DIAGNOSIS SENSOR UNIT
Connector Color	YELLOW

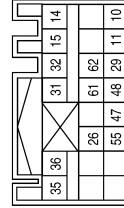

Terminal No.	Color of Wire	Signal Name
10	Y	P-LH1+
11	BG	P-LH1-
14	Y	SQUIB 1-LH +
15	BG	SQUIB 2-LH -
26	L	ODS INPUT

Connector No.	E228
Connector Name	CRASH ZONE SENSOR
Connector Color	YELLOW



Terminal No.	Color of Wire	Signal Name
1	R	-
2	L	-

ABHIA0658GB

SRS AIR BAG SYSTEM

< WIRING DIAGRAM >

Connector No.	B15
Connector Name	FRONT SIDE AIR BAG SATELLITE SENSOR LH
Connector Color	YELLOW



Terminal No.	Color of Wire	Signal Name
1	W	-
2	B	-

Connector No.	B14
Connector Name	FRONT LH SEAT BELT PRE-TENSIONER
Connector Color	YELLOW



Terminal No.	Color of Wire	Signal Name
1	Y	-
2	BG	-

Connector No.	B10
Connector Name	FRONT LH SIDE AIR BAG MODULE
Connector Color	YELLOW



Terminal No.	Color of Wire	Signal Name
1	Y	-
2	BR	-

Connector No.	B38
Connector Name	LH SIDE CURTAIN AIR BAG MODULE
Connector Color	YELLOW



Terminal No.	Color of Wire	Signal Name
1	B	-
2	W	-

Connector No.	B32
Connector Name	WIRE TO WIRE
Connector Color	WHITE

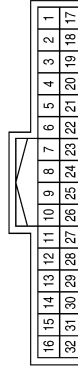

Terminal No.	Color of Wire	Signal Name
17	L	-
25	BR	-

Connector No.	B22
Connector Name	FRONT LH SEAT BELT PRE-TENSIONER
Connector Color	ORANGE



Terminal No.	Color of Wire	Signal Name
3	Y	-
4	BG	-

ABHIA0659GB

A
B
C
D
E
F
G
SRC
I
J
K
L
M
N
O
P

SRS AIR BAG SYSTEM

< WIRING DIAGRAM >

Terminal No.	Color of Wire	Signal Name
31A	BR	-
67A	LG	-

Connector No.	B69
Connector Name	WIRE TO WIRE
Connector Color	GRAY

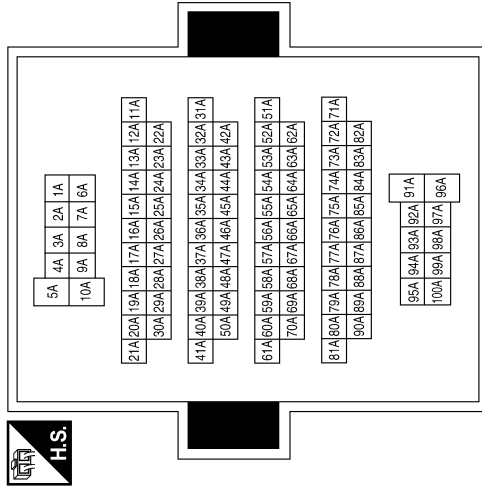

Connector No.	B65
Connector Name	JOINT CONNECTOR-B07
Connector Color	WHITE



Terminal No.	Color of Wire	Signal Name
1	SHIELD	-
2	B	-
3	SHIELD	-



Connector No.	B80
Connector Name	JOINT CONNECTOR-B17
Connector Color	WHITE

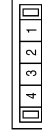

Terminal No.	Color of Wire	Signal Name
1	LG	-
2	LG	-
3	LG	-

Connector No.	B74
Connector Name	WIRE TO WIRE
Connector Color	WHITE

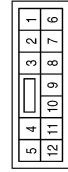

Terminal No.	Color of Wire	Signal Name
3	LG	-
4	B	-

Connector No.	B71
Connector Name	REAR SIDE AIR BAG SATELLITE SENSOR LH
Connector Color	YELLOW



Terminal No.	Color of Wire	Signal Name
1	B	-
2	W	-

ABHIA0660GB

SRS AIR BAG SYSTEM

< WIRING DIAGRAM >

Connector No.	B112
Connector Name	FRONT RH SEAT BELT PRE-TENSIONER
Connector Color	ORANGE



Terminal No.	Color of Wire	Signal Name
3	W	-
4	BG	-

Connector No.	B101
Connector Name	WIRE TO WIRE
Connector Color	WHITE

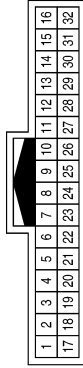

Terminal No.	Color of Wire	Signal Name
19	LG	-

Connector No.	B114
Connector Name	FRONT SIDE AIR BAG SATELLITE SENSOR RH
Connector Color	YELLOW



Terminal No.	Color of Wire	Signal Name
1	B	-
2	W	-

Terminal No.	Color of Wire	Signal Name
30	L	RH SEAT BELT BUCKLE SWITCH +
33	Y	S-RH+
34	BR	S-RH-
37	B	C-RH1+
38	W	C-RH1-
49	B	RH B-PILLAR SATELLITE SENSOR +
50	W	RH B-PILLAR SATELLITE SENSOR -
56	SHIELD	GND
63	B	RH C-PILLAR SATELLITE SENSOR +
64	W	RH C-PILLAR SATELLITE SENSOR -

Connector No.	B113
Connector Name	AIR BAG DAIGNOSIS SENSOR UNIT
Connector Color	YELLOW

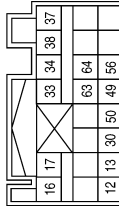

Terminal No.	Color of Wire	Signal Name
12	W	P-RH1+
13	BG	P-RH1-
16	W	SQUIB 1-RH +
17	BG	SQUIB 2-RH -

ABHIA0661GB

A
B
C
D
E
F
G
H
I
J
K
L
M
N
O
P

SRC

SRS AIR BAG SYSTEM

< WIRING DIAGRAM >

Connector No.	B126
Connector Name	FRONT RH SIDE AIR BAG MODULE
Connector Color	YELLOW



Terminal No.	Color of Wire	Signal Name
1	Y	-
2	BR	-

Connector No.	B124
Connector Name	WIRE TO WIRE
Connector Color	WHITE

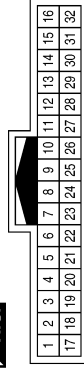

Terminal No.	Color of Wire	Signal Name
17	Y	-
25	BR	-

Connector No.	B123
Connector Name	WIRE TO WIRE
Connector Color	WHITE

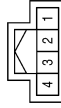

Terminal No.	Color of Wire	Signal Name
1	BR	-
2	B	-
3	Y	-
4	LG	-

Connector No.	B157
Connector Name	WIRE TO WIRE
Connector Color	WHITE

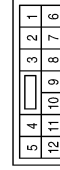

Terminal No.	Color of Wire	Signal Name
3	L	-
4	B	-

Connector No.	B128
Connector Name	RH SIDE CURTAIN AIR BAG MODULE
Connector Color	YELLOW



Terminal No.	Color of Wire	Signal Name
1	B	-
2	W	-

Connector No.	B127
Connector Name	FRONT RH SEAT BELT PRE-TENSIONER
Connector Color	YELLOW



Terminal No.	Color of Wire	Signal Name
1	W	-
2	BG	-

ABHIA0662GB

SRS AIR BAG SYSTEM

< WIRING DIAGRAM >

Connector No.	B220
Connector Name	WIRE TO WIRE
Connector Color	WHITE

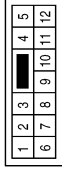

Terminal No.	Color of Wire	Signal Name
3	BG	-
4	GR	-

Connector No.	B170
Connector Name	REAR SIDE AIR BAG SATELLITE SENSOR RH
Connector Color	YELLOW



Terminal No.	Color of Wire	Signal Name
1	W	-
2	B	-

Connector No.	B169
Connector Name	JOINT CONNECTOR-B04
Connector Color	WHITE



Terminal No.	Color of Wire	Signal Name
1	SHIELD	-
2	B	-
3	SHIELD	-

Connector No.	B303
Connector Name	SEAT BELT BUCKLE SWITCH (PASSENGER SEAT)
Connector Color	WHITE



Terminal No.	Color of Wire	Signal Name
3	GR	-
4	BG	-

Connector No.	B300
Connector Name	WIRE TO WIRE
Connector Color	WHITE

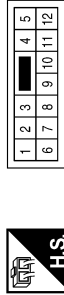

Terminal No.	Color of Wire	Signal Name
3	BG	-
4	GR	-

Connector No.	B221
Connector Name	SEAT BELT BUCKLE SWITCH (DRIVER SEAT)
Connector Color	WHITE



Terminal No.	Color of Wire	Signal Name
3	GR	-
4	BG	-

ABHIA0663GB

A
B
C
D
E
F
G
H
I
J
K
L
M
N
O
P

SRC

SRS AIR BAG SYSTEM

< WIRING DIAGRAM >

Connector No.	B352
Connector Name	OCCUPANT CLASSIFICATION SYSTEM SENSOR FR
Connector Color	PINK

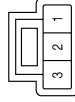

Terminal No.	Color of Wire	Signal Name
1	W/L	-
2	SB	-
3	Y	-

Connector No.	B351
Connector Name	OCCUPANT CLASSIFICATION SYSTEM SENSOR FL
Connector Color	PINK

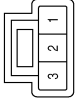

Terminal No.	Color of Wire	Signal Name
1	R/B	-
2	LG	-
3	R	-

Connector No.	B350
Connector Name	WIRE TO WIRE
Connector Color	WHITE

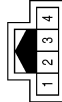

Terminal No.	Color of Wire	Signal Name
1	GR	-
2	B	-
3	BR/W	-
4	W	-

Terminal No.	Color of Wire	Signal Name
14	R	OCCUPANT CLASSIFICATION SYSTEM SENSOR FL VCC
15	SB	OCCUPANT CLASSIFICATION SYSTEM SENSOR FR SIGNAL
16	W/L	OCCUPANT CLASSIFICATION SYSTEM SENSOR FR GND
17	-	-
18	-	-
19	BR/W	ACU COMM
20	-	-

Terminal No.	Color of Wire	Signal Name
7	R/B	OCCUPANT CLASSIFICATION SYSTEM SENSOR FL GND
8	LG	OCCUPANT CLASSIFICATION SYSTEM SENSOR FL SIGNAL
9	B	GND
10	-	-
11	-	-
12	Y	OCCUPANT CLASSIFICATION SYSTEM SENSOR FR VCC
13	-	-

Connector No.	B356
Connector Name	OCCUPANT CLASSIFICATION SYSTEM CONTROL UNIT
Connector Color	BLACK

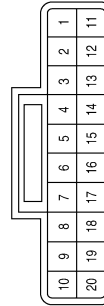

Terminal No.	Color of Wire	Signal Name
1	-	-
2	W	IGN
3	-	-
4	GR	K-LINE
5	-	-
6	-	-

ABHIA0664GB

SRS AIR BAG SYSTEM

< WIRING DIAGRAM >

Connector No.	D103
Connector Name	WIRE TO WIRE
Connector Color	YELLOW

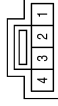

Terminal No.	Color of Wire	Signal Name
1	L	-
2	SHIELD	-
3	Y	-

Connector No.	D26
Connector Name	FRONT DOOR SATELLITE SENSOR LH
Connector Color	YELLOW



Terminal No.	Color of Wire	Signal Name
1	Y	-
2	L	-

Connector No.	D13
Connector Name	WIRE TO WIRE
Connector Color	YELLOW

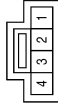

Terminal No.	Color of Wire	Signal Name
1	L	-
2	SHIELD	-
3	Y	-

Connector No.	D126
Connector Name	FRONT DOOR SATELLITE SENSOR RH
Connector Color	YELLOW



Terminal No.	Color of Wire	Signal Name
1	Y	-
2	L	-

ABHIA0665GB

A
B
C
D
E
F
G
SRC
I
J
K
L
M
N
O
P

DIAGNOSIS AND REPAIR WORK FLOW

< BASIC INSPECTION >

BASIC INSPECTION

DIAGNOSIS AND REPAIR WORK FLOW

Work Flow

INFOID:000000009134381

OVERALL SEQUENCE

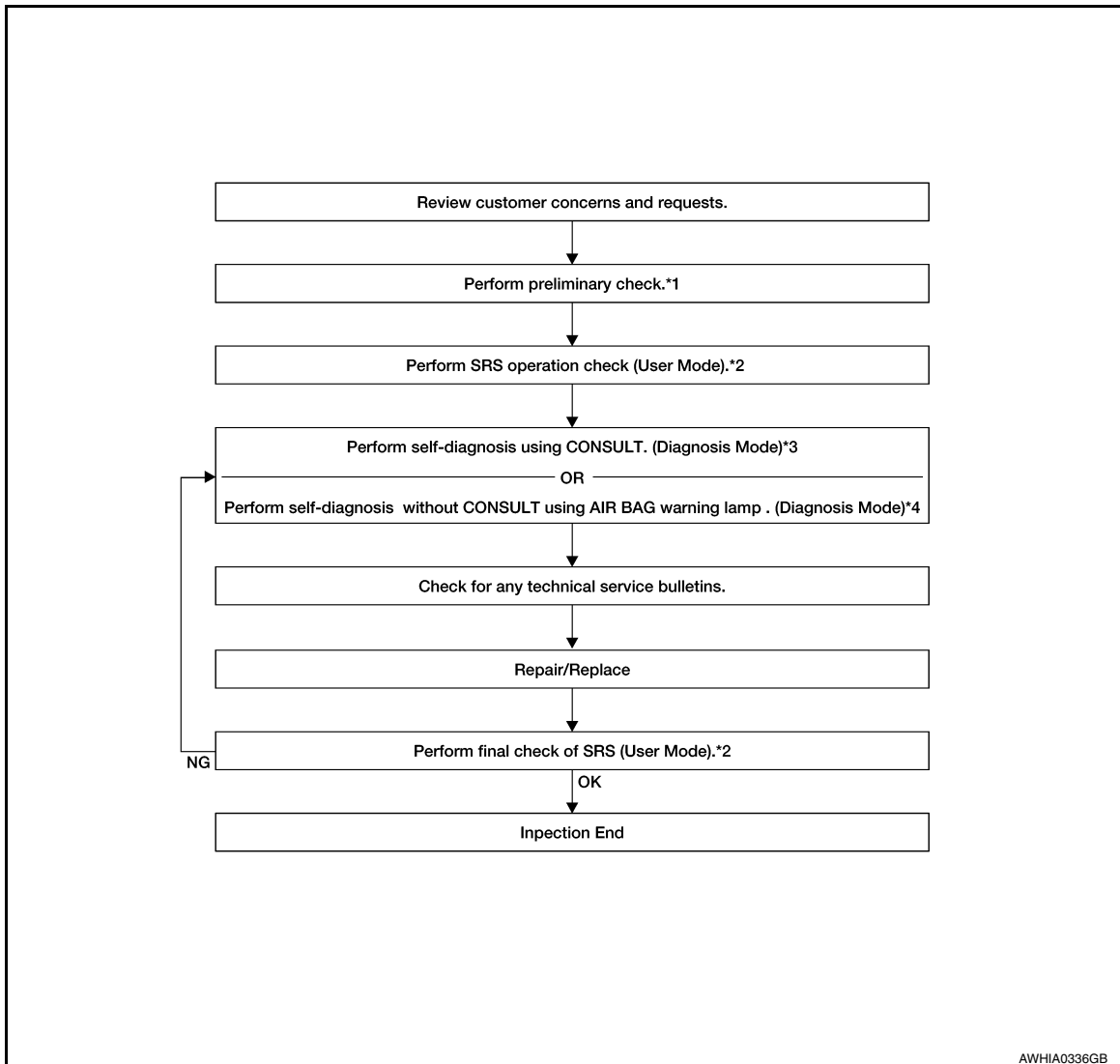

*1 [SRC-15. "Diagnosis Description"](#)

*2 [SRC-15. "SRS Operation Check"](#)

*3 [SRC-16. "Trouble Diagnosis with CONSULT"](#)

*4 [SRC-17. "Trouble Diagnosis without CONSULT"](#)

DETAILED WORK FLOW

1. CUSTOMER INFORMATION

Get detailed information from the customer about the symptom.

>> GO TO 2.

2. PRELIMINARY CHECK

Perform preliminary check. Refer to [SRC-15. "Diagnosis Description"](#).

DIAGNOSIS AND REPAIR WORK FLOW

< BASIC INSPECTION >

>> GO TO 3.

3. SRS OPERATION CHECK (USER MODE)

Perform SRS operation check in User Mode. Refer to [SRC-15, "SRS Operation Check"](#).

>> GO TO 4.

4. SELF-DIAGNOSIS (DIAGNOSIS MODE)

Perform SELF-DIAGNOSIS. Refer to [SRC-16, "Trouble Diagnosis with CONSULT"](#) or [SRC-17, "Trouble Diagnosis without CONSULT"](#).

>> GO TO 5.

5. TECHNICAL SERVICE BULLETINS

Check for technical service bulletins.

>> GO TO 6.

6. REPLACE PART

Replace the malfunctioning part.

>> GO TO 7.

7. FINAL CHECK

Check SRS using Diagnosis Mode and User Mode.

Does Diagnosis Mode and User Mode indicate SRS normal?

YES >> Inspection End.

NO >> GO TO 4.

A
B
C
D
E
F
G
I
J
K
L
M
N
O
P

SRC

INSPECTION AND ADJUSTMENT

< BASIC INSPECTION >

INSPECTION AND ADJUSTMENT

ADDITIONAL SERVICE WHEN REPLACING CONTROL UNIT

ADDITIONAL SERVICE WHEN REPLACING CONTROL UNIT : Description

INFOID:000000009134382

WARNING:

Always perform zero point reset using CONSULT when removing and installing the front passenger seat or servicing the occupant classification system (OCS). If zero point reset is not performed, the OCS may not operate normally, which may increase the risk of serious injury in a collision.

ADDITIONAL SERVICE WHEN REPLACING CONTROL UNIT : Special Repair Requirement

INFOID:000000009134383

WORK PROCEDURE WHEN REPLACING OCS CONTROL UNIT

1.PERFORM ZERO POINT RESET

Perform zero point reset. Refer to [SRC-42, "ZERO POINT RESET : Special Repair Requirement"](#).

>> Inspection End.

ZERO POINT RESET

ZERO POINT RESET : Description

INFOID:000000009134384

Zero point reset is an initializing procedure for the OCS (weight) sensors that must be performed using CONSULT when removing and installing passenger seat or servicing the OCS system. If zero point reset is not performed, the initialization is incomplete and OCS may not operate normally.

NOTE:

- When reinstalling the passenger seat, the initial value for the OCS sensors may change, and the OCS may not operate normally.
- When zero point reset is performed after removal and installation of passenger seat, CONSULT displays "complete".

ZERO POINT RESET : Special Repair Requirement

INFOID:000000009134385

1.PERFORM ZERO POINT RESET

-
1. Perform preliminary checks:

NOTE:

- Level the vehicle
- Minimize vibrations near the vehicle
- Remove any objects on passenger seat
- Do not touch the vehicle during zero point reset

2. Select START on ZERO POINT RESET from, WORK SUPPORT of "OCCUPANT DETECTION".
3. "Zero point reset" starts.

>> GO TO 2.

2.CONFIRM RESET

-
1. Check that "Complete" is displayed on "Zero point reset status".

CAUTION:

- "Complete" may be displayed if the seat has been reinstalled, or "zero point reset" has already been performed.
- "Incomplete" may be displayed if a new seat is installed.
- Air bag warning lamp blinks in user mode if zero point reset is "incomplete".

Is zero point reset status "complete"?

- YES >> Print out "ZERO POINT RESET CURRENT STATUS" screen. Inspection end.
NO >> Recheck the preliminary check items and perform zero point reset again.

INTERMITTENT INCIDENT

< BASIC INSPECTION >

INTERMITTENT INCIDENT

Inspection Procedure

INFOID:000000009134386

INTERMITTENT TROUBLE

An intermittent incident may have occurred in the past but is not being detected currently. This DTC will not be detected on SELF-DIAG [CURRENT], but may be viewed on SELF-DIAG [PAST] if the DTC has not been erased.

Trouble Diagnosis with CONSULT

INFOID:000000009134387

CHECK SRS REPAIR HISTORY

Refer to [SRC-17, "SRS History Check"](#).

A
B
C
D
E
F
G
I
J
K
L
M
N
O
P

SRC

U1000 CAN COMM CIRCUIT

< DTC/CIRCUIT DIAGNOSIS >

DTC/CIRCUIT DIAGNOSIS

U1000 CAN COMM CIRCUIT

Description

INFOID:000000009764366

CAN (Controller Area Network) is a serial communication system for real time application. It is an on-vehicle multiplex communication system with high data communication speed and excellent error detection ability. Many electronic control units are equipped into vehicles, and each control unit shares information and links with other control units during operation. With CAN communication, control units are connected with two communication lines (CAN-H line, CAN-L line) allowing a high rate of information transmission with less wiring. Each control unit transmits and receives data but selectively reads required data only. Refer to [LAN-43. "CAN COMMUNICATION SYSTEM : CAN Communication Signal Chart"](#).

DTC Logic

INFOID:000000009764367

DTC DETECTION LOGIC

CONSULT name	DTC	DTC detecting condition	Repair order
CAN COMMUNICATION FAILURE	U1000	When air bag diagnosis sensor unit is not transmitting or receiving CAN communication signals for 2 or more seconds.	Refer to SRC-44. "Diagnosis Procedure" .

DTC CONFIRMATION PROCEDURE

1. PERFORM SELF-DIAGNOSIS

1. Turn ignition switch ON and wait for 7 seconds or more.
2. Using CONSULT, perform SELF-DIAGNOSIS RESULTS of AIR BAG.
3. Check if any DTC is displayed in the self-diagnosis results.

Is DTC detected?

- YES >> Refer to [SRC-44. "Diagnosis Procedure"](#).
NO >> Refer to [GI-53. "Intermittent Incident"](#).

Diagnosis Procedure

INFOID:000000009764368

1. CHECK CAN COMMUNICATION SYSTEM

Check CAN communication system. Refer to [LAN-26. "Trouble Diagnosis Flow Chart"](#).

>> Inspection End.

U1010 CONTROL UNIT (CAN)

< DTC/CIRCUIT DIAGNOSIS >

U1010 CONTROL UNIT (CAN)

Description

INFOID:000000009764369

Air bag diagnosis sensor performs self-tests on key ON. If CAN communication failure within control unit is detected, DTC is set.

DTC Logic

INFOID:000000009764370

DTC DETECTION LOGIC

CONSULT name	DTC	DTC detecting condition	Repair order
CAN CONTROL UNIT FAILURE	U1010	CAN communication error is detected in control unit.	Refer to SRC-45. "Diagnosis Procedure" .

DTC CONFIRMATION PROCEDURE

1.PERFORM SELF-DIAGNOSIS

1. Turn ignition switch ON.
2. Using CONSULT, perform SELF DIAGNOSIS RESULTS of AIR BAG.
3. Check if DTC is displayed in the self-diagnosis results.

Is DTC detected?

- YES >> Refer to [SRC-45. "Diagnosis Procedure"](#).
NO >> Inspection End.

Diagnosis Procedure

INFOID:000000009764371

1.REPLACE AIR BAG DIAGNOSIS SENSOR UNIT

Replace air bag diagnosis sensor unit. Refer to [SR-27. "Removal and Installation"](#).

>> Inspection End.

A
B
C
D
E
F
G
I
J
K
L
M
N
O
P

SRC

B0001, B0002 DRIVER AIRBAG MODULE

< DTC/CIRCUIT DIAGNOSIS >

B0001, B0002 DRIVER AIRBAG MODULE

Description

INFOID:000000009764372

DTC B0001, B0002 DRIVER AIRBAG MODULE

The driver air bag module is dual stage (US/CAN models) and single stage (MEX models) and wired to the air bag diagnosis sensor unit through the spiral cable. The air bag diagnosis sensor unit will monitor for opens and shorts in detected lines to the driver air bag module including the spiral cable.

PART LOCATION

Refer to [SRC-5, "Component Parts Location"](#).

DTC Logic

INFOID:000000009764373

With CONSULT

CONSULT name	DTC	DTC detecting condition	Repair order
DRIVER AIRBAG MODULE CIRCUIT [OPEN]	B0001	Driver air bag module circuit (DR1) is open (including the spiral cable).	Refer to SRC-47, "Diagnosis Procedure" .
DRIVER AIRBAG MODULE CIRCUIT [VB-SHORT]		Driver air bag module circuit (DR1) is shorted to a power supply circuit (including the spiral cable).	
DRIVER AIRBAG MODULE CIRCUIT [GND-SHORT]		Driver air bag module circuit (DR1) is shorted to ground (including the spiral cable).	
DRIVER AIRBAG MODULE CIRCUIT [SHORT]		Driver air bag module circuits (DR1) are shorted to each other (including the spiral cable).	
DRIVER AIRBAG MODULE 2ND CIRCUIT [OPEN]	B0002	Driver air bag module circuit (DR2) is open (including the spiral cable).	
DRIVER AIRBAG MODULE 2ND CIRCUIT [VB-SHORT]		Driver air bag module circuit (DR2) is shorted to a power supply circuit (including the spiral cable).	
DRIVER AIRBAG MODULE 2ND CIRCUIT [GND-SHORT]		Driver air bag module circuit (DR2) is shorted to ground (including the spiral cable).	
DRIVER AIRBAG MODULE 2ND CIRCUIT [SHORT]		Driver air bag module circuits (DR2) are shorted to each other (including the spiral cable).	

DTC CONFIRMATION PROCEDURE (With CONSULT)

1. CHECK SELF-DIAG RESULT

1. Turn ignition switch ON.
2. Check for DTC using CONSULT.

Is the DTC detected?

YES (Current DTC)>>Refer to [SRC-47, "Diagnosis Procedure"](#).

YES (Past DTC)>>GO TO 2.

NO >> Inspection End.

2. ERASE SELF-DIAG RESULT

Erase the DTC using CONSULT.

Can the DTC be erased?

YES >> Inspection End.

B0001, B0002 DRIVER AIRBAG MODULE

< DTC/CIRCUIT DIAGNOSIS >

NO >> Refer to [SRC-47. "Diagnosis Procedure"](#).

DTC CONFIRMATION PROCEDURE (Without CONSULT)

1. CHECK SELF-DIAG RESULT

1. Turn ignition switch ON.
2. Check the air bag warning lamp status. Refer to [SRC-17. "Trouble Diagnosis without CONSULT"](#).

NOTE:

SRS will not enter diagnosis mode if no malfunction is detected in user mode.

Is the DTC detected?

- YES >> Refer to [SRC-47. "Diagnosis Procedure"](#).
NO >> Inspection End.

Diagnosis Procedure

INFOID:000000009764374

1. HARNESS CONNECTOR

Visually inspect all applicable harness connectors for the following:

- Visible damage to connector or terminal
- Loose terminal
- Poor connection

NOTE:

All harness connectors should be inspected from the air bag diagnosis sensor unit to the end component (including any in-line connectors).

Is the inspection result normal?

- YES >> GO TO 2.
NO >> Perform one of the following repairs:
- Visible damage: Replace the harness.
 - Loose terminal: Secure the terminal.
 - Poor connection: Secure the connection.

2. CONFIRM DTC

1. Reconnect all harness connectors.
2. Turn ignition switch ON.
3. Check for DTC using CONSULT.

Is DTC still current?

- YES >> GO TO 3.
NO >> Refer to [GI-53. "Intermittent Incident"](#).

3. WIRING HARNESS

Check the wiring harness for visible damage.

NOTE:

The entire wiring harness should be inspected from the air bag diagnosis sensor unit to the end component (including any in-line connectors).

Is the inspection result normal?

- YES >> GO TO 4.
NO >> Replace the harness.

4. CHECK SPIRAL CABLE CIRCUIT

1. Turn ignition switch OFF.
2. Disconnect driver air bag module harness connectors and spiral cable harness connector.
3. Check continuity between driver air bag module harness connector and spiral cable connector.

B0001, B0002 DRIVER AIRBAG MODULE

< DTC/CIRCUIT DIAGNOSIS >

Driver air bag module		Spiral cable		Continuity
Connector	Terminal	Connector	Terminal	
M87	9	M53	30	Yes
	12		29	
M89	10		28	
	11		30	

4. Check continuity between driver air bag module harness connector and ground.

Driver air bag module		Ground	Continuity
Connector	Terminal		
M87	9		No
	12		
M89	10		
	11		

Is the inspection result normal?

YES >> GO TO 5.

NO >> Replace the spiral cable. Refer to [SR-15, "Removal and Installation"](#).

5. CONFIRM DTC

1. Reconnect all harness connectors.
2. Turn ignition switch ON.
3. Check for DTC using CONSULT.

Is DTC still current?

YES >> GO TO 6.

NO >> Refer to [GI-53, "Intermittent Incident"](#).

6. AIR BAG DIAGNOSIS SENSOR UNIT

1. Replace the air bag diagnosis sensor unit. Refer to [SR-27, "Removal and Installation"](#).
2. Turn ignition switch ON.
3. Check for DTC using CONSULT.

Is DTC still current?

YES >> GO TO 7.

NO >> Clear DTC. Inspection End.

7. DRIVER AIR BAG MODULE

1. Replace the driver air bag module. Refer to [SR-12, "Removal and Installation"](#).
2. Turn ignition switch ON.
3. Check for DTC using CONSULT.

Is DTC still current?

YES >> GO TO 8.

NO >> Clear DTC. Inspection End.

8. RELATED HARNESS

Replace the related harness.

>> END

B0010, B0011 PASSENGER AIRBAG MODULE

< DTC/CIRCUIT DIAGNOSIS >

B0010, B0011 PASSENGER AIRBAG MODULE

Description

INFOID:000000009764375

DTC B0010, B0011 PASSENGER AIR BAG MODULE

The passenger air bag module is dual stage (US/CAN models) and single stage (MEX models) and is wired to the air bag diagnosis sensor unit. The air bag diagnosis sensor unit will monitor for opens and shorts in detected lines to the passenger air bag module.

PART LOCATION

Refer to [SRC-5, "Component Parts Location"](#).

DTC Logic

INFOID:000000009764376

With CONSULT

CONSULT name	DTC	DTC detecting condition	Repair order
ASSIST AIRBAG MODULE CIRCUIT [OPEN]	B0010	Front passenger air bag module circuit (AS1) is open.	Refer to SRC-50, "Diagnosis Procedure" .
ASSIST AIRBAG MODULE CIRCUIT [VB-SHORT]		Front passenger air bag module circuit (AS1) is shorted to a power supply circuit.	
ASSIST AIRBAG MODULE CIRCUIT [GND-SHORT]		Front passenger air bag module circuit (AS1) is shorted to ground.	
ASSIST AIRBAG MODULE CIRCUIT [SHORT]		Front passenger air bag module circuits (AS1) are shorted to each other.	
ASSIST AIRBAG MODULE 2ND CIRCUIT [OPEN]	B0011	Front passenger air bag module circuit (AS2) is open.	
ASSIST AIRBAG MODULE 2ND CIRCUIT [VB-SHORT]		Front passenger air bag module circuit (AS2) is shorted to a power supply circuit.	
ASSIST AIRBAG MODULE 2ND CIRCUIT [GND-SHORT]		Front passenger air bag module circuit (AS2) is shorted to ground.	
ASSIST AIRBAG MODULE 2ND CIRCUIT [SHORT]		Front passenger air bag module circuits (AS2) are shorted to each other.	

DTC CONFIRMATION PROCEDURE (With CONSULT)

1. CHECK SELF-DIAG RESULT

1. Turn ignition switch ON.
2. Check for DTC using CONSULT.

Is the DTC detected?

YES (Current DTC)>>Refer to [SRC-50, "Diagnosis Procedure"](#).

YES (Past DTC)>>GO TO 2.

NO >> Inspection End.

2. ERASE SELF-DIAG RESULT

Erase the DTC using CONSULT.

Can the DTC be erased?

YES >> Inspection End.

NO >> Refer to [SRC-50, "Diagnosis Procedure"](#).

DTC CONFIRMATION PROCEDURE (Without CONSULT)

1. CHECK SELF-DIAG RESULT

1. Turn ignition switch ON.
2. Check the air bag warning lamp status. Refer to [SRC-17, "Trouble Diagnosis without CONSULT"](#).

B0010, B0011 PASSENGER AIRBAG MODULE

< DTC/CIRCUIT DIAGNOSIS >

NOTE:

SRS will not enter diagnosis mode if no malfunction is detected in user mode.

Is the DTC detected?

- YES >> Refer to [SRC-50. "Diagnosis Procedure"](#).
NO >> Inspection End.

Diagnosis Procedure

INFOID:000000009764377

1. HARNESS CONNECTOR

Visually inspect all applicable harness connectors for the following:

- Visible damage to connector or terminal
- Loose terminal
- Poor connection

NOTE:

All harness connectors should be inspected from the air bag diagnosis unit to the end component (including any in-line connectors).

Is the inspection result normal?

- YES >> GO TO 2.
NO >> Perform one of the following repairs:
 - Visible damage: Replace the harness.
 - Loose terminal: Secure the terminal.
 - Poor connection: Secure the connection.

2. CONFIRM DTC

1. Reconnect all harness connectors.
2. Turn ignition switch ON.
3. Check for DTC using CONSULT.

Is DTC still current?

- YES >> GO TO 3.
NO >> Refer to [GI-53. "Intermittent Incident"](#).

3. WIRING HARNESS

Check the wiring harness for visible damage.

NOTE:

The entire wiring harness should be inspected from the air bag diagnosis sensor unit to the end component (including any in-line connectors).

Is the inspection result normal?

- YES >> GO TO 4.
NO >> Replace the harness.

4. CONFIRM DTC

1. Reconnect all harness connectors.
2. Turn ignition switch ON.
3. Check for DTC using CONSULT.

Is DTC still current?

- YES >> GO TO 5.
NO >> Refer to [GI-53. "Intermittent Incident"](#).

5. AIR BAG DIAGNOSIS SENSOR UNIT

1. Replace the air bag diagnosis sensor unit. Refer to [SR-27. "Removal and Installation"](#).
2. Turn ignition switch ON.
3. Check for DTC using CONSULT.

Is DTC still current?

- YES >> GO TO 6.
NO >> Clear DTC. Inspection End.

6. FRONT PASSENGER AIR BAG MODULE

1. Replace the front passenger air bag module. Refer to [SR-18. "Removal and Installation"](#).

B0010, B0011 PASSENGER AIRBAG MODULE

< DTC/CIRCUIT DIAGNOSIS >

2. Turn ignition switch ON.
3. Check for DTC using CONSULT.

Is DTC still current?

- YES >> GO TO 7.
NO >> Clear DTC. Inspection End.

7. RELATED HARNESS

Replace the related harness.

>> END

A

B

C

D

E

F

G

SRC

I

J

K

L

M

N

O

P

B0020 SIDE AIRBAG MODULE LH

< DTC/CIRCUIT DIAGNOSIS >

B0020 SIDE AIRBAG MODULE LH

Description

INFOID:000000009764378

DTC B0020 FRONT LH SIDE AIR BAG MODULE

The front LH side air bag module is wired to the air bag diagnosis sensor unit. The air bag diagnosis sensor unit will monitor for opens and shorts in detected lines to the front LH side air bag module.

PART LOCATION

Refer to [SRC-5, "Component Parts Location"](#).

DTC Logic

INFOID:000000009764379

With CONSULT

CONSULT name	DTC	DTC detecting condition	Repair order
SIDE AIRBAG MODULE LH CIRCUIT [OPEN]	B0020	Front LH side air bag module circuit is open.	Refer to SRC-52, "Diagnosis Procedure" .
SIDE AIRBAG MODULE LH CIRCUIT [VB-SHORT]		Front LH side air bag module circuit is shorted to a power supply circuit.	
SIDE AIRBAG MODULE LH CIRCUIT [GND-SHORT]		Front LH side air bag module circuit is shorted to ground.	
SIDE AIRBAG MODULE LH CIRCUIT [SHORT]		Front LH side air bag module circuits are shorted to each other.	

DTC CONFIRMATION PROCEDURE (With CONSULT)

1. CHECK SELF-DIAG RESULT

- Turn ignition switch ON.
- Check for DTC using CONSULT.

Is the DTC detected?

YES (Current DTC)>>Refer to [SRC-52, "Diagnosis Procedure"](#).

YES (Past DTC)>>GO TO 2.

NO >> Inspection End.

2. ERASE SELF-DIAG RESULT

Erase the DTC using CONSULT.

Can the DTC be erased?

YES >> Inspection End.

NO >> Refer to [SRC-52, "Diagnosis Procedure"](#).

DTC CONFIRMATION PROCEDURE (Without CONSULT)

1. CHECK SELF-DIAG RESULT

- Turn ignition switch ON.
- Check the air bag warning lamp status. Refer to [SRC-17, "Trouble Diagnosis without CONSULT"](#).

NOTE:

SRS will not enter diagnosis mode if no malfunction is detected in user mode.

Is the DTC detected?

YES >> Refer to [SRC-52, "Diagnosis Procedure"](#).

NO >> Inspection End.

Diagnosis Procedure

INFOID:000000009764380

1. HARNESS CONNECTOR

Visually inspect all applicable harness connectors for the following:

- Visible damage to connector or terminal

B0020 SIDE AIRBAG MODULE LH

< DTC/CIRCUIT DIAGNOSIS >

- Loose terminal
- Poor connection

A

NOTE:

All harness connectors should be inspected from the air bag diagnosis sensor unit to the end component (including any in-line connectors).

B

Is the inspection result normal?

YES >> GO TO 2.

NO >> Perform one of the following repairs:

- Visible damage: Replace the harness.
- Loose terminal: Secure the terminal.
- Poor connection: Secure the connection.

C

2.CONFIRM DTC

D

1. Reconnect all harness connectors.
2. Turn ignition switch ON.
3. Check for DTC using CONSULT.

E

Is DTC still current?

YES >> GO TO 3.

NO >> Refer to [GI-53, "Intermittent Incident"](#).

F

3.WIRING HARNESS

Check the wiring harness for visible damage.

G

NOTE:

The entire wiring harness should be inspected from the air bag diagnosis sensor unit to the end component (including any in-line connectors).

SRC

Is the inspection result normal?

YES >> GO TO 4.

NO >> Replace the harness.

I

4.CONFIRM DTC

1. Reconnect all harness connectors.
2. Turn ignition switch ON.
3. Check for DTC using CONSULT.

J

Is DTC still current?

YES >> GO TO 5.

NO >> Refer to [GI-53, "Intermittent Incident"](#).

K

5.AIR BAG DIAGNOSIS SENSOR UNIT

L

1. Replace the air bag diagnosis sensor unit. Refer to [SR-27, "Removal and Installation"](#).
2. Turn ignition switch ON.
3. Check for DTC using CONSULT.

M

Is DTC still current?

YES >> GO TO 6.

NO >> Clear DTC. Inspection End.

N

6.SIDE AIR BAG MODULE LH

1. Replace the side air bag module LH.
2. Turn ignition switch ON.
3. Check for DTC using CONSULT.

O

Is DTC still current?

YES >> GO TO 7.

NO >> Clear DTC. Inspection End.

P

7.RELATED HARNESS

Replace the related harness.

>> END

B0028 SIDE AIRBAG MODULE RH

< DTC/CIRCUIT DIAGNOSIS >

B0028 SIDE AIRBAG MODULE RH

Description

INFOID:000000009764381

DTC B0028 FRONT RH SIDE AIR BAG MODULE

The front RH side air bag module is wired to the air bag diagnosis sensor unit. The air bag diagnosis sensor unit will monitor for opens and shorts in detected lines to the front RH side air bag module.

PART LOCATION

Refer to [SRC-5, "Component Parts Location"](#).

DTC Logic

INFOID:000000009764382

With CONSULT

CONSULT name	DTC	DTC detecting condition	Repair order
SIDE AIRBAG MODULE RH CIRCUIT [OPEN]	B0028	Front RH side air bag module circuit is open.	Refer to SRC-54, "Diagnosis Procedure" .
SIDE AIRBAG MODULE RH CIRCUIT [VB-SHORT]		Front RH side air bag module circuit is shorted to a power supply circuit.	
SIDE AIRBAG MODULE RH CIRCUIT [GND-SHORT]		Front RH side air bag module circuit is shorted to ground.	
SIDE AIRBAG MODULE RH CIRCUIT [SHORT]		Front RH side air bag module circuits are shorted to each other.	

DTC CONFIRMATION PROCEDURE (With CONSULT)

1. CHECK SELF-DIAG RESULT

1. Turn ignition switch ON.
2. Check for DTC using CONSULT.

Is the DTC detected?

- YES (Current DTC)>>Refer to [SRC-54, "Diagnosis Procedure"](#).
- YES (Past DTC)>>GO TO 2.
- NO >> Inspection End.

2. ERASE SELF-DIAG RESULT

Erase the DTC using CONSULT.

Can the DTC be erased?

- YES >> Inspection End.
- NO >> Refer to [SRC-54, "Diagnosis Procedure"](#).

DTC CONFIRMATION PROCEDURE (Without CONSULT)

1. CHECK SELF-DIAG RESULT

1. Turn ignition switch ON.
2. Check the air bag warning lamp status. Refer to [SRC-17, "Trouble Diagnosis without CONSULT"](#).

NOTE:

SRS will not enter diagnosis mode if no malfunction is detected in user mode.

Is the DTC detected?

- YES >> Refer to [SRC-54, "Diagnosis Procedure"](#).
- NO >> Inspection End.

Diagnosis Procedure

INFOID:000000009764383

1. HARNESS CONNECTOR

Visually inspect all applicable harness connectors for the following:

- Visible damage to connector or terminal

B0028 SIDE AIRBAG MODULE RH

< DTC/CIRCUIT DIAGNOSIS >

- Loose terminal
- Poor connection

A

NOTE:

All harness connectors should be inspected from the air bag diagnosis sensor unit to the end component (including any in-line connectors).

B

Is the inspection result normal?

YES >> GO TO 2.

NO >> Perform one of the following repairs:

- Visible damage: Replace the harness.
- Loose terminal: Secure the terminal.
- Poor connection: Secure the connection.

C

2.CONFIRM DTC

D

1. Reconnect all harness connectors.
2. Turn ignition switch ON.
3. Check for DTC using CONSULT.

E

Is DTC still current?

YES >> GO TO 3.

NO >> Refer to [GI-53, "Intermittent Incident"](#).

F

3.WIRING HARNESS

Check the wiring harness for visible damage.

G

NOTE:

The entire wiring harness should be inspected from the air bag diagnosis sensor unit to the end component (including any in-line connectors).

SRC

Is the inspection result normal?

YES >> GO TO 4.

NO >> Replace the harness.

I

4.CONFIRM DTC

1. Reconnect all harness connectors.
2. Turn ignition switch ON.
3. Check for DTC using CONSULT.

J

Is DTC still current?

YES >> GO TO 5.

NO >> Refer to [GI-53, "Intermittent Incident"](#).

K

5.AIR BAG DIAGNOSIS SENSOR UNIT

L

1. Replace the air bag diagnosis sensor unit. Refer to [SR-27, "Removal and Installation"](#).
2. Turn ignition switch ON.
3. Check for DTC using CONSULT.

M

Is DTC still current?

YES >> GO TO 6.

NO >> Clear DTC. Inspection End.

N

6.SIDE AIR BAG MODULE RH

1. Replace the side air bag module RH.
2. Turn ignition switch ON.
3. Check for DTC using CONSULT.

O

Is DTC still current?

YES >> GO TO 7.

NO >> Clear DTC. Inspection End.

P

7.RELATED HARNESS

Replace the related harness.

>> END

B0021 SIDE CURTAIN AIR BAG MODULE LH

< DTC/CIRCUIT DIAGNOSIS >

B0021 SIDE CURTAIN AIR BAG MODULE LH

Description

INFOID:000000009764384

DTC B0021 LH SIDE CURTAIN AIR BAG MODULE

The LH side curtain air bag module is wired to the air bag diagnosis sensor unit. The air bag diagnosis sensor unit will monitor for opens and shorts in detected lines to the LH side curtain air bag module.

PART LOCATION

Refer to [SRC-5, "Component Parts Location"](#).

DTC Logic

INFOID:000000009764385

With CONSULT

CONSULT name	DTC	DTC detecting condition	Repair order
CURTAIN AIRBAG MODULE LH CIRCUIT [OPEN]	B0021	LH side curtain air bag module circuit is open.	Refer to SRC-56, "Diagnosis Procedure" .
CURTAIN AIRBAG MODULE LH CIRCUIT [VB-SHORT]		LH side curtain air bag module circuit is shorted to a power supply circuit.	
CURTAIN AIRBAG MODULE LH CIRCUIT [GND-SHORT]		LH side curtain air bag module circuit is shorted to ground.	
CURTAIN AIRBAG MODULE LH CIRCUIT [SHORT]		LH side curtain air bag module circuits are shorted to each other.	

DTC CONFIRMATION PROCEDURE (With CONSULT)

1. CHECK SELF-DIAG RESULT

1. Turn ignition switch ON.
2. Check for DTC using CONSULT.

Is the DTC detected?

YES (Current DTC)>>Refer to [SRC-56, "Diagnosis Procedure"](#).

YES (Past DTC)>>GO TO 2.

NO >> Inspection End.

2. ERASE SELF-DIAG RESULT

Erase the DTC using CONSULT.

Can the DTC be erased?

YES >> Inspection End.

NO >> Refer to [SRC-56, "Diagnosis Procedure"](#).

DTC CONFIRMATION PROCEDURE (Without CONSULT)

1. CHECK SELF-DIAG RESULT

1. Turn ignition switch ON.
2. Check the air bag warning lamp status. Refer to [SRC-17, "Trouble Diagnosis without CONSULT"](#).

NOTE:

SRS will not enter diagnosis mode if no malfunction is detected in user mode.

Is the DTC detected?

YES >> Refer to [SRC-56, "Diagnosis Procedure"](#).

NO >> Inspection End.

Diagnosis Procedure

INFOID:000000009764386

1. HARNESS CONNECTOR

Visually inspect all applicable harness connectors for the following:

- Visible damage to connector or terminal

B0021 SIDE CURTAIN AIR BAG MODULE LH

< DTC/CIRCUIT DIAGNOSIS >

- Loose terminal
- Poor connection

A

NOTE:

All harness connectors should be inspected from the air bag diagnosis sensor unit to the end component (including any in-line connectors).

B

Is the inspection result normal?

YES >> GO TO 2.

NO >> Perform one of the following repairs:

- Visible damage: Replace the harness.
- Loose terminal: Secure the terminal.
- Poor connection: Secure the connection.

C

2.CONFIRM DTC

D

1. Reconnect all harness connectors.
2. Turn ignition switch ON.
3. Check for DTC using CONSULT.

E

Is DTC still current?

YES >> GO TO 3.

NO >> Refer to [GI-53, "Intermittent Incident"](#).

F

3.WIRING HARNESS

Check the wiring harness for visible damage.

G

NOTE:

The entire wiring harness should be inspected from the air bag diagnosis sensor unit to the end component (including any in-line connectors).

SRC

Is the inspection result normal?

YES >> GO TO 4.

NO >> Replace the harness.

I

4.CONFIRM DTC

1. Reconnect all harness connectors.
2. Turn ignition switch ON.
3. Check for DTC using CONSULT.

J

Is DTC still current?

YES >> GO TO 5.

NO >> Refer to [GI-53, "Intermittent Incident"](#).

K

5.AIR BAG DIAGNOSIS SENSOR UNIT

L

1. Replace the air bag diagnosis sensor unit. Refer to [SR-27, "Removal and Installation"](#).
2. Turn ignition switch ON.
3. Check for DTC using CONSULT.

M

Is DTC still current?

YES >> GO TO 6.

NO >> Clear DTC. Inspection End.

N

6.SIDE CURTAIN AIR BAG MODULE LH

1. Replace the side curtain air bag module LH. Refer to [SR-20, "Removal and Installation"](#).
2. Turn ignition switch ON.
3. Check for DTC using CONSULT.

O

Is DTC still current?

YES >> GO TO 7.

NO >> Clear DTC. Inspection End.

P

7.RELATED HARNESS

Replace the related harness.

>> END

B0029 SIDE CURTAIN AIR BAG MODULE RH

< DTC/CIRCUIT DIAGNOSIS >

B0029 SIDE CURTAIN AIR BAG MODULE RH

Description

INFOID:000000009764387

DTC B0029 RH SIDE CURTAIN AIR BAG MODULE

The RH side curtain air bag module is wired to the air bag diagnosis sensor unit. The air bag diagnosis sensor unit will monitor for opens and shorts in detected lines to the RH side curtain air bag module.

PART LOCATION

Refer to [SRC-5, "Component Parts Location"](#).

DTC Logic

INFOID:000000009764388

With CONSULT

CONSULT name	DTC	DTC detecting condition	Repair order
CURTAIN AIRBAG MODULE RH CIRCUIT [OPEN]	B0029	RH side curtain air bag module circuit is open.	Refer to SRC-58, "Diagnosis Procedure" .
CURTAIN AIRBAG MODULE RH CIRCUIT [VB-SHORT]		RH side curtain air bag module circuit is shorted to a power supply circuit.	
CURTAIN AIRBAG MODULE RH CIRCUIT [GND-SHORT]		RH side curtain air bag module circuit is shorted to ground.	
CURTAIN AIRBAG MODULE RH CIRCUIT [SHORT]		RH side curtain air bag module circuits are shorted to each other.	

DTC CONFIRMATION PROCEDURE (With CONSULT)

1. CHECK SELF-DIAG RESULT

1. Turn ignition switch ON.
2. Check for DTC using CONSULT.

Is the DTC detected?

YES (Current DTC)>>Refer to [SRC-58, "Diagnosis Procedure"](#).

YES (Past DTC)>>GO TO 2.

NO >> Inspection End.

2. ERASE SELF-DIAG RESULT

Erase the DTC using CONSULT.

Can the DTC be erased?

YES >> Inspection End.

NO >> Refer to [SRC-58, "Diagnosis Procedure"](#).

DTC CONFIRMATION PROCEDURE (Without CONSULT)

1. CHECK SELF-DIAG RESULT

1. Turn ignition switch ON.
2. Check the air bag warning lamp status. Refer to [SRC-17, "Trouble Diagnosis without CONSULT"](#).

NOTE:

SRS will not enter diagnosis mode if no malfunction is detected in user mode.

Is the DTC detected?

YES >> Refer to [SRC-58, "Diagnosis Procedure"](#).

NO >> Inspection End.

Diagnosis Procedure

INFOID:000000009764389

1. HARNESS CONNECTOR

Visually inspect all applicable harness connectors for the following:

B0029 SIDE CURTAIN AIR BAG MODULE RH

< DTC/CIRCUIT DIAGNOSIS >

- Visible damage to connector or terminal
- Loose terminal
- Poor connection

A

NOTE:

All harness connectors should be inspected from the air bag diagnosis sensor unit to the end component (including any in-line connectors).

B

Is the inspection result normal?

YES >> GO TO 2.

C

NO >> Perform one of the following repairs:

- Visible damage: Replace the harness.
- Loose terminal: Secure the terminal.
- Poor connection: Secure the connection.

D

2. CONFIRM DTC

1. Reconnect all harness connectors.
2. Turn ignition switch ON.
3. Check for DTC using CONSULT.

E

Is DTC still current?

YES >> GO TO 3.

F

NO >> Refer to [GI-53, "Intermittent Incident"](#).

3. WIRING HARNESS

Check the wiring harness for visible damage.

NOTE:

The entire wiring harness should be inspected from the air bag diagnosis sensor unit to the end component (including any in-line connectors).

SRC

Is the inspection result normal?

YES >> GO TO 4.

I

NO >> Replace the harness.

4. CONFIRM DTC

1. Reconnect all harness connectors.
2. Turn ignition switch ON.
3. Check for DTC using CONSULT.

J

Is DTC still current?

YES >> GO TO 5.

K

NO >> Refer to [GI-53, "Intermittent Incident"](#).

5. AIR BAG DIAGNOSIS SENSOR UNIT

1. Replace the air bag diagnosis sensor unit. Refer to [SR-27, "Removal and Installation"](#).
2. Turn ignition switch ON.
3. Check for DTC using CONSULT.

L

M

Is DTC still current?

YES >> GO TO 6.

N

NO >> Clear DTC. Inspection End.

6. SIDE CURTAIN AIR BAG MODULE RH

1. Replace the side curtain air bag module RH. Refer to [SR-20, "Removal and Installation"](#).
2. Turn ignition switch ON.
3. Check for DTC using CONSULT.

O

Is DTC still current?

P

YES >> GO TO 7.

NO >> Clear DTC. Inspection End.

7. RELATED HARNESS

Replace the related harness.

>> END

B0094 CRASH ZONE SENSOR

< DTC/CIRCUIT DIAGNOSIS >

B0094 CRASH ZONE SENSOR

Description

INFOID:000000009764390

DTC B0094 CRASH ZONE SENSOR

The crash zone sensor is wired to the air bag diagnosis sensor unit. The air bag diagnosis sensor unit will monitor for opens and shorts in detected lines to the crash zone sensor.

PART LOCATION

Refer to [SRC-5, "Component Parts Location"](#).

DTC Logic

INFOID:000000009764391

With CONSULT

CONSULT name	DTC	DTC detecting condition	Repair order
CRASH ZONE SENSOR [SENSOR FAIL]	B0094	Crash zone sensor has malfunctioned.	Refer to SRC-61, "Diagnosis Procedure" .
CRASH ZONE SENSOR [COMM FAIL]		Crash zone sensor communication error.	
CRASH ZONE SENSOR [DISCONNECT]		Crash zone sensor is disconnected.	
CRASH ZONE SENSOR [UNMATCH]		Crash zone sensor is out of specification.	
CRASH ZONE SENSOR [GND-SHORT]		Crash zone sensor circuit is shorted to ground.	

DTC CONFIRMATION PROCEDURE (With CONSULT)

1. CHECK SELF-DIAG RESULT

1. Turn ignition switch ON.
2. Check for DTC using CONSULT.

Is the DTC detected?

- YES (Current DTC)>>Refer to [SRC-61, "Diagnosis Procedure"](#).
YES (Past DTC)>>GO TO 2.
NO >> Inspection End.

2. ERASE SELF-DIAG RESULT

Erase the DTC using CONSULT.

Can the DTC be erased?

- YES >> Inspection End.
NO >> Refer to [SRC-61, "Diagnosis Procedure"](#).

DTC CONFIRMATION PROCEDURE (Without CONSULT)

1. CHECK SELF-DIAG RESULT

1. Turn ignition switch ON.
2. Check the air bag warning lamp status. Refer to [SRC-17, "Trouble Diagnosis without CONSULT"](#).

NOTE:

SRS will not enter diagnosis mode if no malfunction is detected in user mode.

Is the DTC detected?

- YES >> Refer to [SRC-61, "Diagnosis Procedure"](#).
NO >> Inspection End.

B0094 CRASH ZONE SENSOR

< DTC/CIRCUIT DIAGNOSIS >

Diagnosis Procedure

INFOID:000000009764392

1. HARNESS CONNECTOR

Visually inspect all applicable harness connectors for the following:

- Visible damage to connector or terminal
- Loose terminal
- Poor connection

NOTE:

All harness connectors should be inspected from the air bag diagnosis sensor unit to the end component (including any in-line connectors).

Is the inspection result normal?

YES >> GO TO 2.

NO >> Perform one of the following repairs:

- Visible damage: Replace the harness.
- Loose terminal: Secure the terminal.
- Poor connection: Secure the connection.

2. CONFIRM DTC

1. Reconnect all harness connectors.
2. Turn ignition switch ON.
3. Check for DTC using CONSULT.

Is DTC still current?

YES >> GO TO 3.

NO >> Refer to [GI-53, "Intermittent Incident"](#).

3. WIRING HARNESS

Check the wiring harness for visible damage.

NOTE:

The entire wiring harness should be inspected from the air bag diagnosis sensor unit to the end component (including any in-line connectors).

Is the inspection result normal?

YES >> GO TO 4.

NO >> Replace the harness.

4. CONFIRM DTC

1. Reconnect all harness connectors.
2. Turn ignition switch ON.
3. Check for DTC using CONSULT.

Is DTC still current?

YES >> GO TO 5.

NO >> Refer to [GI-53, "Intermittent Incident"](#).

5. CRASH ZONE SENSOR

1. Replace the crash zone sensor. Refer to [SR-23, "Removal and Installation"](#).
2. Turn ignition switch ON.
3. Check for DTC using CONSULT.

Is DTC still current?

YES >> GO TO 6.

NO >> Clear DTC. Inspection End.

6. AIR BAG DIAGNOSIS SENSOR UNIT

1. Replace the air bag diagnosis sensor unit. Refer to [SR-27, "Removal and Installation"](#).
2. Turn ignition switch ON.
3. Check for DTC using CONSULT.

Is DTC still current?

YES >> GO TO 7.

NO >> Clear DTC. Inspection End.

A

B

C

D

E

F

G

SRC

I

J

K

L

M

N

O

P

B0094 CRASH ZONE SENSOR

< DTC/CIRCUIT DIAGNOSIS >

7.RELATED HARNESS

Replace the related harness.

>> **END**

B0091 FRONT SIDE AIR BAG SATELLITE SENSOR LH

< DTC/CIRCUIT DIAGNOSIS >

B0091 FRONT SIDE AIR BAG SATELLITE SENSOR LH

Description

INFOID:000000009764393

DTC B0091 FRONT SATELLITE SENSOR LH

The front side air bag satellite sensor LH is wired to the air bag diagnosis sensor unit. The air bag diagnosis sensor unit will monitor the front side air bag satellite sensor LH for internal failures and its circuits for communication errors.

PART LOCATION

Refer to [SRC-5, "Component Parts Location"](#).

DTC Logic

INFOID:000000009764394

With CONSULT

CONSULT name	DTC	DTC detecting condition	Repair order
B-PILLAR SATELLITE SENSOR LH [SENSOR FAIL]	B0091	Front side air bag satellite sensor LH has malfunctioned.	Refer to SRC-64, "Diagnosis Procedure" .
B-PILLAR SATELLITE SENSOR LH [COMM FAIL]		Front side air bag satellite sensor LH communication error.	
B-PILLAR SATELLITE SENSOR LH [DISCONNECT]		Front side air bag satellite sensor LH is disconnected.	
B-PILLAR SATELLITE SENSOR LH [UNMATCH]		Front side air bag satellite sensor LH is out of specification.	
B-PILLAR SATELLITE SENSOR LH [GND-SHORT]		Front side air bag satellite sensor LH circuit is shorted to ground.	

DTC CONFIRMATION PROCEDURE (With CONSULT)

1.CHECK SELF-DIAG RESULT

1. Turn ignition switch ON.
2. Check for DTC using CONSULT.

Is the DTC detected?

- YES (Current DTC)>>Refer to [SRC-64, "Diagnosis Procedure"](#).
- YES (Past DTC)>>GO TO 2.
- NO >> Inspection End.

2.ERASE SELF-DIAG RESULT

Erase the DTC using CONSULT.

Can the DTC be erased?

- YES >> Inspection End.
- NO >> Refer to [SRC-64, "Diagnosis Procedure"](#).

DTC CONFIRMATION PROCEDURE (Without CONSULT)

1.CHECK SELF-DIAG RESULT

1. Turn ignition switch ON.
2. Check the air bag warning lamp status. Refer to [SRC-17, "Trouble Diagnosis without CONSULT"](#).

NOTE:

SRS will not enter diagnosis mode if no malfunction is detected in user mode.

Is the DTC detected?

- YES >> Refer to [SRC-64, "Diagnosis Procedure"](#).
- NO >> Inspection End.

B0091 FRONT SIDE AIR BAG SATELLITE SENSOR LH

< DTC/CIRCUIT DIAGNOSIS >

Diagnosis Procedure

INFOID:000000009764395

1. HARNESS CONNECTOR

Visually inspect all applicable harness connectors for the following:

- Visible damage to connector or terminal
- Loose terminal
- Poor connection

NOTE:

All harness connectors should be inspected from the air bag diagnosis sensor unit to the end component (including any in-line connectors).

Is the inspection result normal?

YES >> GO TO 2.

- NO >> Perform one of the following repairs:
- Visible damage: Replace the harness.
 - Loose terminal: Secure the terminal.
 - Poor connection: Secure the connection.

2. CONFIRM DTC

1. Reconnect all harness connectors.
2. Turn ignition switch ON.
3. Check for DTC using CONSULT.

Is DTC still current?

YES >> GO TO 3.

NO >> Refer to [GI-53, "Intermittent Incident"](#).

3. WIRING HARNESS

Check the wiring harness for visible damage.

NOTE:

The entire wiring harness should be inspected from the air bag diagnosis sensor unit to the end component (including any in-line connectors).

Is the inspection result normal?

YES >> GO TO 4.

NO >> Replace the harness.

4. CONFIRM DTC

1. Reconnect all harness connectors.
2. Turn ignition switch ON.
3. Check for DTC using CONSULT.

Is DTC still current?

YES >> GO TO 5.

NO >> Refer to [GI-53, "Intermittent Incident"](#).

5. FRONT SIDE AIR BAG SATELLITE SENSOR LH

1. Replace the front side air bag satellite sensor LH. Refer to [SR-25, "Removal and Installation"](#).
2. Turn ignition switch ON.
3. Check for DTC using CONSULT.

Is DTC still current?

YES >> GO TO 6.

NO >> Clear DTC. Inspection End.

6. AIR BAG DIAGNOSIS SENSOR UNIT

1. Replace the air bag diagnosis sensor unit. Refer to [SR-27, "Removal and Installation"](#).
2. Turn ignition switch ON.
3. Check for DTC using CONSULT.

Is DTC still current?

YES >> GO TO 7.

NO >> Clear DTC. Inspection End.

B0091 FRONT SIDE AIR BAG SATELLITE SENSOR LH

< DTC/CIRCUIT DIAGNOSIS >

7.RELATED HARNESS

Replace the related harness.

>> END

A
B
C
D
E
F
G
I
J
K
L
M
N
O
P

SRC

B0096 FRONT SIDE AIR BAG SATELLITE SENSOR RH

< DTC/CIRCUIT DIAGNOSIS >

B0096 FRONT SIDE AIR BAG SATELLITE SENSOR RH

Description

INFOID:000000009764396

DTC B0096 FRONT SATELLITE SENSOR RH

The front side air bag satellite sensor RH is wired to the air bag diagnosis sensor unit. The air bag diagnosis sensor unit will monitor the front side air bag satellite sensor RH for internal failures and its circuits for communication errors.

PART LOCATION

Refer to [SRC-5, "Component Parts Location"](#).

DTC Logic

INFOID:000000009764397

With CONSULT

CONSULT name	DTC	DTC detecting condition	Repair order
B-PILLAR SATELLITE SENSOR RH [SENSOR FAIL]	B0096	Front side air bag satellite sensor RH has malfunctioned.	Refer to SRC-67, "Diagnosis Procedure" .
B-PILLAR SATELLITE SENSOR RH [COMM FAIL]		Front side air bag satellite sensor RH communication error.	
B-PILLAR SATELLITE SENSOR RH [DISCONNECT]		Front side air bag satellite sensor RH is disconnected.	
B-PILLAR SATELLITE SENSOR RH [UNMATCH]		Front side air bag satellite sensor RH is out of specification.	
B-PILLAR SATELLITE SENSOR RH [GND-SHORT]		Front side air bag satellite sensor RH circuit is shorted to ground.	

DTC CONFIRMATION PROCEDURE (With CONSULT)

1. CHECK SELF-DIAG RESULT

1. Turn ignition switch ON.
2. Check for DTC using CONSULT.

Is the DTC detected?

- YES (Current DTC)>>Refer to [SRC-67, "Diagnosis Procedure"](#).
- YES (Past DTC)>>GO TO 2.
- NO >> Inspection End.

2. ERASE SELF-DIAG RESULT

Erase the DTC using CONSULT.

Can the DTC be erased?

- YES >> Inspection End.
- NO >> Refer to [SRC-67, "Diagnosis Procedure"](#).

DTC CONFIRMATION PROCEDURE (Without CONSULT)

1. CHECK SELF-DIAG RESULT

1. Turn ignition switch ON.
2. Check the air bag warning lamp status. Refer to [SRC-17, "Trouble Diagnosis without CONSULT"](#).

NOTE:

SRS will not enter diagnosis mode if no malfunction is detected in user mode.

Is the DTC detected?

- YES >> Refer to [SRC-67, "Diagnosis Procedure"](#).
- NO >> Inspection End.

B0096 FRONT SIDE AIR BAG SATELLITE SENSOR RH

< DTC/CIRCUIT DIAGNOSIS >

Diagnosis Procedure

INFOID:000000009764398

1. HARNESS CONNECTOR

Visually inspect all applicable harness connectors for the following:

- Visible damage to connector or terminal
- Loose terminal
- Poor connection

NOTE:

All harness connectors should be inspected from the air bag diagnosis sensor unit to the end component (including any in-line connectors).

Is the inspection result normal?

YES >> GO TO 2.

- NO >> Perform one of the following repairs:
- Visible damage: Replace the harness.
 - Loose terminal: Secure the terminal.
 - Poor connection: Secure the connection.

2. CONFIRM DTC

1. Reconnect all harness connectors.
2. Turn ignition switch ON.
3. Check for DTC using CONSULT.

Is DTC still current?

YES >> GO TO 3.

NO >> Refer to [GI-53, "Intermittent Incident"](#).

3. WIRING HARNESS

Check the wiring harness for visible damage.

NOTE:

The entire wiring harness should be inspected from the air bag diagnosis sensor unit to the end component (including any in-line connectors).

Is the inspection result normal?

YES >> GO TO 4.

NO >> Replace the harness.

4. CONFIRM DTC

1. Reconnect all harness connectors.
2. Turn ignition switch ON.
3. Check for DTC using CONSULT.

Is DTC still current?

YES >> GO TO 5.

NO >> Refer to [GI-53, "Intermittent Incident"](#).

5. FRONT SIDE AIR BAG SATELLITE SENSOR RH

1. Replace the front side air bag satellite sensor RH. Refer to [SR-25, "Removal and Installation"](#).
2. Turn ignition switch ON.
3. Check for DTC using CONSULT.

Is DTC still current?

YES >> GO TO 6.

NO >> Clear DTC. Inspection End.

6. AIR BAG DIAGNOSIS SENSOR UNIT

1. Replace the air bag diagnosis sensor unit. Refer to [SR-27, "Removal and Installation"](#).
2. Turn ignition switch ON.
3. Check for DTC using CONSULT.

Is DTC still current?

YES >> GO TO 7.

NO >> Clear DTC. Inspection End.

A
B
C
D
E
F
G
I
J
K
L
M
N
O
P

SRC

B0096 FRONT SIDE AIR BAG SATELLITE SENSOR RH

< DTC/CIRCUIT DIAGNOSIS >

7.RELATED HARNESS

Replace the related harness.

>> END

B0092 REAR SIDE AIR BAG SATELLITE SENSOR LH

< DTC/CIRCUIT DIAGNOSIS >

B0092 REAR SIDE AIR BAG SATELLITE SENSOR LH

Description

INFOID:000000009764399

DTC B0092 REAR SATELLITE SENSOR LH

The rear side air bag satellite sensor LH is wired to the air bag diagnosis sensor unit. The air bag diagnosis sensor unit will monitor the rear side air bag satellite sensor LH for internal failures and its circuits for communication errors.

PART LOCATION

Refer to [SRC-5, "Component Parts Location"](#).

DTC Logic

INFOID:000000009764400

With CONSULT

CONSULT name	DTC	DTC detecting condition	Repair order
C-PILLAR SATELLITE SENSOR LH [SENSOR FAIL]	B0092	Rear side air bag satellite sensor LH has malfunctioned.	Refer to SRC-69, "Diagnosis Procedure" .
C-PILLAR SATELLITE SENSOR LH [COMM FAIL]		Rear side air bag satellite sensor LH communication error.	
C-PILLAR SATELLITE SENSOR LH [DISCONNECT]		Rear side air bag satellite sensor LH is disconnected.	
C-PILLAR SATELLITE SENSOR LH [UNMATCH]		Rear side air bag satellite sensor LH is out of specification.	
C-PILLAR SATELLITE SENSOR LH [GND-SHORT]		Rear side air bag satellite sensor LH circuit is shorted to ground.	

DTC CONFIRMATION PROCEDURE (With CONSULT)

1.CHECK SELF-DIAG RESULT

- Turn ignition switch ON.
- Check for DTC using CONSULT.

Is the DTC detected?

- YES (Current DTC)>>Refer to [SRC-69, "Diagnosis Procedure"](#).
- YES (Past DTC)>>GO TO 2.
- NO >> Inspection End.

2.ERASE SELF-DIAG RESULT

Erase the DTC using CONSULT.

Can the DTC be erased?

- YES >> Inspection End.
- NO >> Refer to [SRC-69, "Diagnosis Procedure"](#).

DTC CONFIRMATION PROCEDURE (Without CONSULT)

1.CHECK SELF-DIAG RESULT

- Turn ignition switch ON.
- Check the air bag warning lamp status. Refer to [SRC-17, "Trouble Diagnosis without CONSULT"](#).

NOTE:

SRS will not enter diagnosis mode if no malfunction is detected in user mode.

Is the DTC detected?

- YES >> Refer to [SRC-69, "Diagnosis Procedure"](#).
- NO >> Inspection End.

Diagnosis Procedure

INFOID:000000009764401

B0092 REAR SIDE AIR BAG SATELLITE SENSOR LH

< DTC/CIRCUIT DIAGNOSIS >

1. HARNESS CONNECTOR

Visually inspect all applicable harness connectors for the following:

- Visible damage to connector or terminal
- Loose terminal
- Poor connection

NOTE:

All harness connectors should be inspected from the air bag diagnosis sensor unit to the end component (including any in-line connectors).

Is the inspection result normal?

YES >> GO TO 2.

- NO >> Perform one of the following repairs:
- Visible damage: Replace the harness.
 - Loose terminal: Secure the terminal.
 - Poor connection: Secure the connection.

2. CONFIRM DTC

1. Reconnect all harness connectors.
2. Turn ignition switch ON.
3. Check for DTC using CONSULT.

Is DTC still current?

YES >> GO TO 3.

NO >> Refer to [GI-53, "Intermittent Incident"](#).

3. WIRING HARNESS

Check the wiring harness for visible damage.

NOTE:

The entire wiring harness should be inspected from the air bag diagnosis sensor unit to the end component (including any in-line connectors).

Is the inspection result normal?

YES >> GO TO 4.

NO >> Replace the harness.

4. CONFIRM DTC

1. Reconnect all harness connectors.
2. Turn ignition switch ON.
3. Check for DTC using CONSULT.

Is DTC still current?

YES >> GO TO 5.

NO >> Refer to [GI-53, "Intermittent Incident"](#).

5. REAR SIDE AIR BAG SATELLITE SENSOR LH

1. Replace the rear side air bag satellite sensor LH. Refer to [SR-25, "Removal and Installation"](#).
2. Turn ignition switch ON.
3. Check for DTC using CONSULT.

Is DTC still current?

YES >> GO TO 6.

NO >> Clear DTC. Inspection End.

6. AIR BAG DIAGNOSIS SENSOR UNIT

1. Replace the air bag diagnosis sensor unit. Refer to [SR-27, "Removal and Installation"](#).
2. Turn ignition switch ON.
3. Check for DTC using CONSULT.

Is DTC still current?

YES >> GO TO 7.

NO >> Clear DTC. Inspection End.

7. RELATED HARNESS

B0092 REAR SIDE AIR BAG SATELLITE SENSOR LH

< DTC/CIRCUIT DIAGNOSIS >

Replace the related harness.

>> END

A

B

C

D

E

F

G

SRC

I

J

K

L

M

N

O

P

B0097 REAR SIDE AIR BAG SATELLITE SENSOR RH

< DTC/CIRCUIT DIAGNOSIS >

B0097 REAR SIDE AIR BAG SATELLITE SENSOR RH

Description

INFOID:000000009764402

DTC B0097 REAR SATELLITE SENSOR RH

The rear side air bag satellite sensor RH is wired to the air bag diagnosis sensor unit. The air bag diagnosis sensor unit will monitor the rear side air bag satellite sensor RH for internal failures and its circuits for communication errors.

PART LOCATION

Refer to [SRC-5, "Component Parts Location"](#).

DTC Logic

INFOID:000000009764403

With CONSULT

CONSULT name	DTC	DTC detecting condition	Repair order
C-PILLAR SATELLITE SENSOR RH [SENSOR FAIL]	B0097	Rear side air bag satellite sensor RH has malfunctioned.	Refer to SRC-73, "Diagnosis Procedure" .
C-PILLAR SATELLITE SENSOR RH [COMM FAIL]		Rear side air bag satellite sensor RH communication error.	
C-PILLAR SATELLITE SENSOR RH [DISCONNECT]		Rear side air bag satellite sensor RH is disconnected.	
C-PILLAR SATELLITE SENSOR RH [UNMATCH]		Rear side air bag satellite sensor RH is out of specification.	
C-PILLAR SATELLITE SENSOR RH [GND-SHORT]		Rear side air bag satellite sensor RH circuit is shorted to ground.	

DTC CONFIRMATION PROCEDURE (With CONSULT)

1. CHECK SELF-DIAG RESULT

1. Turn ignition switch ON.
2. Check for DTC using CONSULT.

Is the DTC detected?

- YES (Current DTC)>>Refer to [SRC-73, "Diagnosis Procedure"](#).
- YES (Past DTC)>>GO TO 2.
- NO >> Inspection End.

2. ERASE SELF-DIAG RESULT

Erase the DTC using CONSULT.

Can the DTC be erased?

- YES >> Inspection End.
- NO >> Refer to [SRC-73, "Diagnosis Procedure"](#).

DTC CONFIRMATION PROCEDURE (Without CONSULT)

1. CHECK SELF-DIAG RESULT

1. Turn ignition switch ON.
2. Check the air bag warning lamp status. Refer to [SRC-17, "Trouble Diagnosis without CONSULT"](#).

NOTE:

SRS will not enter diagnosis mode if no malfunction is detected in user mode.

Is the DTC detected?

- YES >> Refer to [SRC-73, "Diagnosis Procedure"](#).
- NO >> Inspection End.

B0097 REAR SIDE AIR BAG SATELLITE SENSOR RH

< DTC/CIRCUIT DIAGNOSIS >

Diagnosis Procedure

INFOID:000000009764404

1. HARNESS CONNECTOR

Visually inspect all applicable harness connectors for the following:

- Visible damage to connector or terminal
- Loose terminal
- Poor connection

NOTE:

All harness connectors should be inspected from the air bag diagnosis sensor unit to the end component (including any in-line connectors).

Is the inspection result normal?

YES >> GO TO 2.

- NO >> Perform one of the following repairs:
- Visible damage: Replace the harness.
 - Loose terminal: Secure the terminal.
 - Poor connection: Secure the connection.

2. CONFIRM DTC

1. Reconnect all harness connectors.
2. Turn ignition switch ON.
3. Check for DTC using CONSULT.

Is DTC still current?

YES >> GO TO 3.

NO >> Refer to [GI-53, "Intermittent Incident"](#).

3. WIRING HARNESS

Check the wiring harness for visible damage.

NOTE:

The entire wiring harness should be inspected from the air bag diagnosis sensor unit to the end component (including any in-line connectors).

Is the inspection result normal?

YES >> GO TO 4.

NO >> Replace the harness.

4. CONFIRM DTC

1. Reconnect all harness connectors.
2. Turn ignition switch ON.
3. Check for DTC using CONSULT.

Is DTC still current?

YES >> GO TO 5.

NO >> Refer to [GI-53, "Intermittent Incident"](#).

5. REAR SIDE AIR BAG SATELLITE SENSOR RH

1. Replace the rear side air bag satellite sensor RH. Refer to [SR-25, "Removal and Installation"](#).
2. Turn ignition switch ON.
3. Check for DTC using CONSULT.

Is DTC still current?

YES >> GO TO 6.

NO >> Clear DTC. Inspection End.

6. AIR BAG DIAGNOSIS SENSOR UNIT

1. Replace the air bag diagnosis sensor unit. Refer to [SR-27, "Removal and Installation"](#).
2. Turn ignition switch ON.
3. Check for DTC using CONSULT.

Is DTC still current?

YES >> GO TO 7.

NO >> Clear DTC. Inspection End.

A
B
C
D
E
F
G
I
J
K
L
M
N
O
P

SRC

B0097 REAR SIDE AIR BAG SATELLITE SENSOR RH

< DTC/CIRCUIT DIAGNOSIS >

7.RELATED HARNESS

Replace the related harness.

>> END

B0093 FRONT DOOR SATELLITE SENSOR LH

< DTC/CIRCUIT DIAGNOSIS >

B0093 FRONT DOOR SATELLITE SENSOR LH

Description

INFOID:000000009764405

DTC B0093 FRONT DOOR SATELLITE SENSOR LH

The front door satellite sensor LH is wired to the air bag diagnosis sensor unit. The air bag diagnosis sensor unit will monitor the front door satellite sensor LH for internal failures and its circuits for communication errors.

PART LOCATION

Refer to [SRC-5, "Component Parts Location"](#).

DTC Logic

INFOID:000000009764406

With CONSULT

CONSULT name	DTC	DTC detecting condition	Repair order
DOOR SATELLITE SENSOR LH [SENSOR FAIL]	B0093	Front door satellite sensor LH has malfunctioned.	Refer to SRC-75, "Diagnosis Procedure" .
DOOR SATELLITE SENSOR LH [COMM FAIL]		Front door satellite sensor LH communication error.	
DOOR SATELLITE SENSOR LH [DISCONNECT]		Front door satellite sensor LH is disconnected.	
DOOR SATELLITE SENSOR LH [UNMATCH]		Front door satellite sensor LH is out of specification.	
DOOR SATELLITE SENSOR LH [GND-SHORT]		Front door satellite sensor LH circuit is shorted to ground.	

DTC CONFIRMATION PROCEDURE (With CONSULT)

1. CHECK SELF-DIAG RESULT

1. Turn ignition switch ON.
2. Check for DTC using CONSULT.

Is the DTC detected?

- YES (Current DTC)>>Refer to [SRC-75, "Diagnosis Procedure"](#).
- YES (Past DTC)>>GO TO 2.
- NO >> Inspection End.

2. ERASE SELF-DIAG RESULT

Erase the DTC using CONSULT.

Can the DTC be erased?

- YES >> Inspection End.
- NO >> Refer to [SRC-75, "Diagnosis Procedure"](#).

DTC CONFIRMATION PROCEDURE (Without CONSULT)

1. CHECK SELF-DIAG RESULT

1. Turn ignition switch ON.
2. Check the air bag warning lamp status. Refer to [SRC-17, "Trouble Diagnosis without CONSULT"](#).

NOTE:

SRS will not enter diagnosis mode if no malfunction is detected in user mode.

Is the DTC detected?

- YES >> Refer to [SRC-75, "Diagnosis Procedure"](#).
- NO >> Inspection End.

Diagnosis Procedure

INFOID:000000009764407

1. HARNESS CONNECTOR

B0093 FRONT DOOR SATELLITE SENSOR LH

< DTC/CIRCUIT DIAGNOSIS >

Visually inspect all applicable harness connectors for the following:

- Visible damage to connector or terminal
- Loose terminal
- Poor connection

NOTE:

All harness connectors should be inspected from the air bag diagnosis sensor unit to the end component (including any in-line connectors).

Is the inspection result normal?

YES >> GO TO 2.

- NO >> Perform one of the following repairs:
- Visible damage: Replace the harness.
 - Loose terminal: Secure the terminal.
 - Poor connection: Secure the connection.

2.CONFIRM DTC

1. Reconnect all harness connectors.
2. Turn ignition switch ON.
3. Check for DTC using CONSULT.

Is DTC still current?

YES >> GO TO 3.

NO >> Refer to [GI-53. "Intermittent Incident"](#).

3.WIRING HARNESS

Check the wiring harness for visible damage.

NOTE:

The entire wiring harness should be inspected from the air bag diagnosis sensor unit to the end component (including any in-line connectors).

Is the inspection result normal?

YES >> GO TO 4.

NO >> Replace the harness.

4.CONFIRM DTC

1. Reconnect all harness connectors.
2. Turn ignition switch ON.
3. Check for DTC using CONSULT.

Is DTC still current?

YES >> GO TO 5.

NO >> Refer to [GI-53. "Intermittent Incident"](#).

5.FRONT DOOR SATELLITE SENSOR LH

1. Replace the front door satellite sensor LH. Refer to [SR-25. "Removal and Installation"](#).
2. Turn ignition switch ON.
3. Check for DTC using CONSULT.

Is DTC still current?

YES >> GO TO 6.

NO >> Clear DTC. Inspection End.

6.AIR BAG DIAGNOSIS SENSOR UNIT

1. Replace the air bag diagnosis sensor unit. Refer to [SR-27. "Removal and Installation"](#).
2. Turn ignition switch ON.
3. Check for DTC using CONSULT.

Is DTC still current?

YES >> GO TO 7.

NO >> Clear DTC. Inspection End.

7.RELATED HARNESS

Replace the related harness.

B0093 FRONT DOOR SATELLITE SENSOR LH

< DTC/CIRCUIT DIAGNOSIS >

>> END

A

B

C

D

E

F

G

SRC

I

J

K

L

M

N

O

P

B0098 FRONT DOOR SATELLITE SENSOR RH

< DTC/CIRCUIT DIAGNOSIS >

B0098 FRONT DOOR SATELLITE SENSOR RH

Description

INFOID:000000009764408

DTC B0098 FRONT DOOR SATELLITE SENSOR RH

The front door satellite sensor RH is wired to the air bag diagnosis sensor unit. The air bag diagnosis sensor unit will monitor the front door satellite sensor RH for internal failures and its circuits for communication errors.

PART LOCATION

Refer to [SRC-5, "Component Parts Location"](#).

DTC Logic

INFOID:000000009764409

With CONSULT

CONSULT name	DTC	DTC detecting condition	Repair order
DOOR SATELLITE SENSOR RH [SENSOR FAIL]	B0098	Front door satellite sensor RH has malfunctioned.	Refer to SRC-78, "Diagnosis Procedure" .
DOOR SATELLITE SENSOR RH [COMM FAIL]		Front door satellite sensor RH communication error.	
DOOR SATELLITE SENSOR RH [DISCONNECT]		Front door satellite sensor RH is disconnected.	
DOOR SATELLITE SENSOR RH [UNMATCH]		Front door satellite sensor RH is out of specification.	
DOOR SATELLITE SENSOR RH [GND-SHORT]		Front door satellite sensor RH circuit is shorted to ground.	

DTC CONFIRMATION PROCEDURE (With CONSULT)

1. CHECK SELF-DIAG RESULT

- Turn ignition switch ON.
- Check for DTC using CONSULT.

Is the DTC detected?

- YES (Current DTC)>>Refer to [SRC-78, "Diagnosis Procedure"](#).
- YES (Past DTC)>>GO TO 2.
- NO >> Inspection End.

2. ERASE SELF-DIAG RESULT

Erase the DTC using CONSULT.

Can the DTC be erased?

- YES >> Inspection End.
- NO >> Refer to [SRC-78, "Diagnosis Procedure"](#).

DTC CONFIRMATION PROCEDURE (Without CONSULT)

1. CHECK SELF-DIAG RESULT

- Turn ignition switch ON.
- Check the air bag warning lamp status. Refer to [SRC-17, "Trouble Diagnosis without CONSULT"](#).

NOTE:

SRS will not enter diagnosis mode if no malfunction is detected in user mode.

Is the DTC detected?

- YES >> Refer to [SRC-78, "Diagnosis Procedure"](#).
- NO >> Inspection End.

Diagnosis Procedure

INFOID:000000009764410

1. HARNESS CONNECTOR

B0098 FRONT DOOR SATELLITE SENSOR RH

< DTC/CIRCUIT DIAGNOSIS >

Visually inspect all applicable harness connectors for the following:

- Visible damage to connector or terminal
- Loose terminal
- Poor connection

A

NOTE:

All harness connectors should be inspected from the air bag diagnosis sensor unit to the end component (including any in-line connectors).

B

Is the inspection result normal?

C

YES >> GO TO 2.

- NO >> Perform one of the following repairs:
- Visible damage: Replace the harness.
 - Loose terminal: Secure the terminal.
 - Poor connection: Secure the connection.

D

2.CONFIRM DTC

1. Reconnect all harness connectors.
2. Turn ignition switch ON.
3. Check for DTC using CONSULT.

E

Is DTC still current?

F

YES >> GO TO 3.

NO >> Refer to [GI-53, "Intermittent Incident"](#).

G

3.WIRING HARNESS

Check the wiring harness for visible damage.

NOTE:

The entire wiring harness should be inspected from the air bag diagnosis sensor unit to the end component (including any in-line connectors).

SRC

Is the inspection result normal?

I

YES >> GO TO 4.

NO >> Replace the harness.

4.CONFIRM DTC

J

1. Reconnect all harness connectors.
2. Turn ignition switch ON.
3. Check for DTC using CONSULT.

K

Is DTC still current?

YES >> GO TO 5.

NO >> Refer to [GI-53, "Intermittent Incident"](#).

L

5.FRONT DOOR SATELLITE SENSOR RH

1. Replace the front door satellite sensor RH. Refer to [SR-25, "Removal and Installation"](#).
2. Turn ignition switch ON.
3. Check for DTC using CONSULT.

M

Is DTC still current?

N

YES >> GO TO 6.

NO >> Clear DTC. Inspection End.

6.AIR BAG DIAGNOSIS SENSOR UNIT

O

1. Replace the air bag diagnosis sensor unit. Refer to [SR-27, "Removal and Installation"](#).
2. Turn ignition switch ON.
3. Check for DTC using CONSULT.

P

Is DTC still current?

YES >> GO TO 7.

NO >> Clear DTC. Inspection End.

7.RELATED HARNESS

Replace the related harness.

B0098 FRONT DOOR SATELLITE SENSOR RH

< DTC/CIRCUIT DIAGNOSIS >

>> **END**

B00A0 OCS SYSTEM

< DTC/CIRCUIT DIAGNOSIS >

B00A0 OCS SYSTEM

Description

INFOID:000000009764411

DTC B00A0 OCCUPANT CLASSIFICATION SYSTEM (OCS)

The OCS control unit is wired to the air bag diagnosis sensor unit. The air bag diagnosis sensor unit will monitor the OCS for failures and interruptions in communication between the OCS control unit and the air bag diagnosis sensor unit.

PART LOCATION

Refer to [SRC-5, "Component Parts Location"](#).

DTC Logic

INFOID:000000009764412

With CONSULT

CONSULT name	DTC	DTC detecting condition	Repair order
OCCUPANT DETECTION SENSOR UNIT [UNIT FAIL]	B00A0	The OCS control unit is malfunctioning.	Refer to SRC-82, "Diagnosis Procedure" .
OCCUPANT DETECTION SENSOR UNIT [NO DATA]			
OCCUPANT DETECTION SENSOR UNIT [UNDEFINED]			
OCCUPANT DETECTION SENSOR UNIT [RESET FAIL]			
OCCUPANT DETECTION SENSOR [UNIT FAIL]		The OCS sensor is malfunctioning.	
OCCUPANT DETECTION SENSOR [POWER FAIL]		The OCS sensor circuit is malfunctioning.	
OCCUPANT DETECTION SENSOR UNIT [COMM FAIL]		Communication between the OCS control unit and the air bag diagnosis sensor unit is interrupted.	

DTC CONFIRMATION PROCEDURE (With CONSULT)

1. CHECK SELF-DIAG RESULT

1. Turn ignition switch ON.
2. Check for DTC using CONSULT.

Is the DTC detected?

YES (Current DTC)>>Refer to [SRC-82, "Diagnosis Procedure"](#).

YES (Past DTC)>>GO TO 2.

NO >> Inspection End.

2. ERASE SELF-DIAG RESULT

Erase the DTC using CONSULT.

Can the DTC be erased?

YES >> Inspection End.

NO >> Refer to [SRC-82, "Diagnosis Procedure"](#).

DTC CONFIRMATION PROCEDURE (Without CONSULT)

1. CHECK SELF-DIAG RESULT

1. Turn ignition switch ON.
2. Check the air bag warning lamp status. Refer to [SRC-17, "Trouble Diagnosis without CONSULT"](#).

NOTE:

SRS will not enter diagnosis mode if no malfunction is detected in user mode.

B00A0 OCS SYSTEM

< DTC/CIRCUIT DIAGNOSIS >

Is the DTC detected?

- YES >> Refer to [SRC-82, "Diagnosis Procedure"](#).
NO >> Inspection End.

Diagnosis Procedure

INFOID:000000009764413

Recheck SRS after each corrective action.

1. HARNESS CONNECTOR

Visually inspect all applicable harness connectors for the following:

- Visible damage to connector or terminal
- Loose terminal
- Poor connection

NOTE:

All harness connectors should be inspected from the air bag diagnosis unit to the end component (including any in-line connectors).

Is the inspection result normal?

- YES >> GO TO 2.
NO >> Perform one of the following repairs:
- Visible damage: Replace the harness.
 - Loose terminal: Secure the terminal.
 - Poor connection: Secure the connection.

2. CONFIRM DTC

1. Reconnect all harness connectors.
2. Turn ignition switch ON.
3. Check for DTC using CONSULT.

Is DTC still current?

- YES >> GO TO 3.
NO >> Refer to [GI-53, "Intermittent Incident"](#).

3. WIRING HARNESS

Check the wiring harness for visible damage.

NOTE:

The entire wiring harness should be inspected from the air bag diagnosis sensor unit to the end component (including any in-line connectors).

Is the inspection result normal?

- YES >> GO TO 4.
NO >> Replace the harness.

4. CONFIRM DTC

1. Reconnect all harness connectors.
2. Turn ignition switch ON.
3. Check for DTC using CONSULT.

Is DTC still current?

- YES >> GO TO 5.
NO >> Refer to [GI-53, "Intermittent Incident"](#).

5. REPLACE OCCUPANT CLASSIFICATION SYSTEM CONTROL UNIT

1. Replace the occupant classification control unit. Refer to [SR-31, "Removal and Installation"](#).
2. Turn ignition switch ON.
3. Check for DTC using CONSULT.

Is DTC still current?

- YES >> GO TO 6.
NO >> Clear DTC. Inspection End.

6. AIR BAG DIAGNOSIS SENSOR UNIT

1. Replace the air bag diagnosis sensor unit. Refer to [SR-27, "Removal and Installation"](#).
2. Turn ignition switch ON.

B00A0 OCS SYSTEM

< DTC/CIRCUIT DIAGNOSIS >

3. Check for DTC using CONSULT.

Is DTC still current?

YES >> GO TO 7.

NO >> Clear DTC. Inspection End.

7.RELATED HARNESS

Replace the related harness.

>> **END**

A

B

C

D

E

F

G

SRC

I

J

K

L

M

N

O

P

B00D5 PASSENGER AIR BAG OFF INDICATOR

< DTC/CIRCUIT DIAGNOSIS >

B00D5 PASSENGER AIR BAG OFF INDICATOR

Description

INFOID:000000009764414

DTC B00D5 FRONT PASSENGER AIR BAG OFF INDICATOR

The front passenger air bag off indicator is wired to the air bag diagnosis sensor unit. The air bag diagnosis sensor unit monitors the front passenger air bag off indicator and circuit for failures.

PART LOCATION

Refer to [SRC-5, "Component Parts Location"](#).

DTC Logic

INFOID:000000009764415

With CONSULT

CONSULT name	DTC	DTC detecting condition	Repair order
PASSENGER AIRBAG INDICATOR CIRCUIT [FAIL]	B00D5	Front passenger air bag OFF indicator is malfunctioning.	Refer to SRC-84, "Diagnosis Procedure" .
PASSENGER AIRBAG INDICATOR CIRCUIT [OPEN]		Front passenger air bag OFF indicator circuit is open.	
PASSENGER AIRBAG INDICATOR CIRCUIT [VB-SHORT]		Front passenger air bag OFF indicator is shorted to a power supply circuit.	
PASSENGER AIRBAG INDICATOR CIRCUIT [GND-SHORT]		Front passenger air bag OFF indicator is shorted to ground.	

DTC CONFIRMATION PROCEDURE (With CONSULT)

1. CHECK SELF-DIAG RESULT

- Turn ignition switch ON.
- Check for DTC using CONSULT.

Is the DTC detected?

YES (Current DTC)>>Refer to [SRC-84, "Diagnosis Procedure"](#).

YES (Past DTC)>>GO TO 2.

NO >> Inspection End.

2. ERASE SELF-DIAG RESULT

Erase the DTC using CONSULT.

Can the DTC be erased?

YES >> Inspection End.

NO >> Refer to [SRC-84, "Diagnosis Procedure"](#).

DTC CONFIRMATION PROCEDURE (Without CONSULT)

1. CHECK SELF-DIAG RESULT

- Turn ignition switch ON.
- Check the air bag warning lamp status. Refer to [SRC-17, "Trouble Diagnosis without CONSULT"](#).

NOTE:

SRS will not enter diagnosis mode if no malfunction is detected in user mode.

Is the DTC detected?

YES >> Refer to [SRC-84, "Diagnosis Procedure"](#).

NO >> Inspection End.

Diagnosis Procedure

INFOID:000000009764416

1. HARNESS CONNECTOR

Visually inspect all applicable harness connectors for the following:

B00D5 PASSENGER AIR BAG OFF INDICATOR

< DTC/CIRCUIT DIAGNOSIS >

- Visible damage to connector or terminal
- Loose terminal
- Poor connection

A

NOTE:

All harness connectors should be inspected from the air bag diagnosis sensor unit to the end component (including any in-line connectors).

B

Is the inspection result normal?

YES >> GO TO 2.

C

NO >> Perform one of the following repairs:

- Visible damage: Replace the harness.
- Loose terminal: Secure the terminal.
- Poor connection: Secure the connection.

D

2.CONFIRM DTC

1. Reconnect all harness connectors.
2. Turn ignition switch ON.
3. Check for DTC using CONSULT.

E

Is DTC still current?

YES >> GO TO 3.

F

NO >> Refer to [GI-53. "Intermittent Incident"](#).

3.WIRING HARNESS

G

Check the wiring harness for visible damage.

NOTE:

The entire wiring harness should be inspected from the air bag diagnosis sensor unit to the end component (including any in-line connectors).

SRC

Is the inspection result normal?

YES >> GO TO 4.

I

NO >> Replace the harness.

4.CONFIRM DTC

1. Reconnect all harness connectors.
2. Turn ignition switch ON.
3. Check for DTC using CONSULT.

J

Is DTC still current?

YES >> GO TO 5.

K

NO >> Refer to [GI-53. "Intermittent Incident"](#).

5.PASSENGER AIR BAG OFF INDICATOR

L

1. Replace the passenger air bag off indicator. Refer to [IP-22. "CLUSTER LID C LOWER : Removal and Installation"](#).
2. Turn ignition switch ON.
3. Check for DTC using CONSULT.

M

Is DTC still current?

YES >> GO TO 6.

N

NO >> Clear DTC. Inspection End.

6.AIR BAG DIAGNOSIS SENSOR UNIT

O

1. Replace the air bag diagnosis sensor unit. Refer to [SR-27. "Removal and Installation"](#).
2. Turn ignition switch ON.
3. Check for DTC using CONSULT.

P

Is DTC still current?

YES >> GO TO 7.

NO >> Clear DTC. Inspection End.

7.RELATED HARNESS

Replace the related harness.

B00D5 PASSENGER AIR BAG OFF INDICATOR

< DTC/CIRCUIT DIAGNOSIS >

>> **END**

B1428 SEAT BELT BUCKLE SWITCH LH

< DTC/CIRCUIT DIAGNOSIS >

B1428 SEAT BELT BUCKLE SWITCH LH

Description

INFOID:000000009764417

DTC B1428 SEAT BELT BUCKLE SWITCH LH

The air bag diagnosis sensor unit monitors the seat belt buckle switch LH status. If the control unit detects an open or short condition in the circuit, it will set the DTC.

PART LOCATION

Refer to [SRC-5, "Component Parts Location"](#).

DTC Logic

INFOID:000000009764418

With CONSULT

CONSULT name	DTC	DTC detecting condition	Repair order
SEAT BELT BUCKLE SW LH CIRCUIT [OPEN]	B1428	Seat belt buckle switch LH circuit is open.	Refer to SRC-87, "Diagnosis Procedure" .
SEAT BELT BUCKLE SW LH CIRCUIT [VB-SHORT]		Seat belt buckle switch LH circuit is shorted to a power supply circuit.	
SEAT BELT BUCKLE SW LH CIRCUIT [GND-SHORT]		Seat belt buckle switch LH circuit is shorted to ground.	
SEAT BELT BUCKLE SW LH CIRCUIT [UNDEFINED]		Seat belt buckle switch LH circuit is malfunctioning.	

DTC CONFIRMATION PROCEDURE (With CONSULT)

1. CHECK SELF-DIAG RESULT

1. Turn ignition switch ON.
2. Check for DTC using CONSULT.

Is the DTC detected?

YES (Current DTC)>>Refer to [SRC-87, "Diagnosis Procedure"](#).

YES (Past DTC)>>GO TO 2.

NO >> Inspection End.

2. ERASE SELF-DIAG RESULT

Erase the DTC using CONSULT.

Can the DTC be erased?

YES >> Inspection End.

NO >> Refer to [SRC-87, "Diagnosis Procedure"](#).

DTC CONFIRMATION PROCEDURE (Without CONSULT)

1. CHECK SELF-DIAG RESULT

1. Turn ignition switch ON.
2. Check the air bag warning lamp status. Refer to [SRC-17, "Trouble Diagnosis without CONSULT"](#).

NOTE:

SRS will not enter diagnosis mode if no malfunction is detected in user mode.

Is the DTC detected?

YES >> Refer to [SRC-87, "Diagnosis Procedure"](#).

NO >> Inspection End.

Diagnosis Procedure

INFOID:000000009764419

1. HARNESS CONNECTOR

Visually inspect all applicable harness connectors for the following:

- Visible damage to connector or terminal

B1428 SEAT BELT BUCKLE SWITCH LH

< DTC/CIRCUIT DIAGNOSIS >

- Loose terminal
- Poor connection

NOTE:

All harness connectors should be inspected from the air bag diagnosis unit to the end component (including any in-line connectors).

Is the inspection result normal?

YES >> GO TO 2.

- NO >> Perform one of the following repairs:
- Visible damage: Replace the harness.
 - Loose terminal: Secure the terminal.
 - Poor connection: Secure the connection.

2. CONFIRM DTC

1. Reconnect all harness connectors.
2. Turn ignition switch ON.
3. Check for DTC using CONSULT.

Is DTC still current?

YES >> GO TO 3

NO >> Refer to [GI-53, "Intermittent Incident"](#).

3. WIRING HARNESS

Check the wiring harness for visible damage.

NOTE:

The entire wiring harness should be inspected from the air bag diagnosis sensor unit to the end component (including any in-line connectors).

Is the inspection result normal?

YES >> GO TO 4.

NO >> Replace the harness.

4. CONFIRM DTC

1. Reconnect all harness connectors.
2. Turn ignition switch ON.
3. Check for DTC using CONSULT.

Is DTC still current?

YES >> GO TO 5.

NO >> Refer to [GI-53, "Intermittent Incident"](#).

5. SEAT BELT BUCKLE SWITCH LH

1. Replace the seat belt buckle switch LH. Refer to [SR-30, "Removal and Installation"](#).
2. Turn ignition switch ON.
3. Check for DTC using CONSULT.

Is DTC still current?

YES >> GO TO 6.

NO >> Clear DTC. Inspection End.

6. AIR BAG DIAGNOSIS SENSOR UNIT

1. Replace the air bag diagnosis sensor unit. Refer to [SR-27, "Removal and Installation"](#).
2. Turn ignition switch ON.
3. Check for DTC using CONSULT.

Is DTC still current?

YES >> GO TO 7.

NO >> Clear DTC. Inspection End.

7. RELATED HARNESS

Replace the related harness.

>> END

B1429 SEAT BELT BUCKLE SWITCH RH

< DTC/CIRCUIT DIAGNOSIS >

B1429 SEAT BELT BUCKLE SWITCH RH

Description

INFOID:000000009764420

DTC B1429 SEAT BELT BUCKLE SWITCH RH

The air bag diagnosis sensor unit monitors the seat belt buckle switch RH status. If the control unit detects an open or short condition in the circuit, it will set the DTC.

PART LOCATION

Refer to [SRC-5, "Component Parts Location"](#).

DTC Logic

INFOID:000000009764421

With CONSULT

CONSULT name	DTC	DTC detecting condition	Repair order
SEAT BELT BUCKLE SW RH CIRCUIT [OPEN]	B1429	Seat belt buckle switch RH circuit is open.	Refer to SRC-89, "Diagnosis Procedure" .
SEAT BELT BUCKLE SW RH CIRCUIT [VB-SHORT]		Seat belt buckle switch RH circuit is shorted to a power supply circuit.	
SEAT BELT BUCKLE SW RH CIRCUIT [GND-SHORT]		Seat belt buckle switch RH circuit is shorted to ground.	
SEAT BELT BUCKLE SW RH CIRCUIT [UNDEFINED]		Seat belt buckle switch RH circuit is malfunctioning.	

DTC CONFIRMATION PROCEDURE (With CONSULT)

1. CHECK SELF-DIAG RESULT

1. Turn ignition switch ON.
2. Check for DTC using CONSULT.

Is the DTC detected?

YES (Current DTC)>>Refer to [SRC-89, "Diagnosis Procedure"](#).

YES (Past DTC)>>GO TO 2.

NO >> Inspection End.

2. ERASE SELF-DIAG RESULT

Erase the DTC using CONSULT.

Can the DTC be erased?

YES >> Inspection End.

NO >> Refer to [SRC-89, "Diagnosis Procedure"](#).

DTC CONFIRMATION PROCEDURE (Without CONSULT)

1. CHECK SELF-DIAG RESULT

1. Turn ignition switch ON.
2. Check the air bag warning lamp status. Refer to [SRC-17, "Trouble Diagnosis without CONSULT"](#).

NOTE:

SRS will not enter diagnosis mode if no malfunction is detected in user mode.

Is the DTC detected?

YES >> Refer to [SRC-89, "Diagnosis Procedure"](#).

NO >> Inspection End.

Diagnosis Procedure

INFOID:000000009764422

1. HARNESS CONNECTOR

Visually inspect all applicable harness connectors for the following:

- Visible damage to connector or terminal

B1429 SEAT BELT BUCKLE SWITCH RH

< DTC/CIRCUIT DIAGNOSIS >

- Loose terminal
- Poor connection

NOTE:

All harness connectors should be inspected from the air bag diagnosis unit to the end component (including any in-line connectors).

Is the inspection result normal?

- YES >> GO TO 2.
NO >> Perform one of the following repairs:
- Visible damage: Replace the harness.
 - Loose terminal: Secure the terminal.
 - Poor connection: Secure the connection.

2. CONFIRM DTC

1. Reconnect all harness connectors.
2. Turn ignition switch ON.
3. Check for DTC using CONSULT.

Is DTC still current?

- YES >> GO TO 3
NO >> Refer to [GI-53, "Intermittent Incident"](#).

3. WIRING HARNESS

Check the wiring harness for visible damage.

NOTE:

The entire wiring harness should be inspected from the air bag diagnosis sensor unit to the end component (including any in-line connectors).

Is the inspection result normal?

- YES >> GO TO 4.
NO >> Replace the harness.

4. CONFIRM DTC

1. Reconnect all harness connectors.
2. Turn ignition switch ON.
3. Check for DTC using CONSULT.

Is DTC still current?

- YES >> GO TO 5.
NO >> Refer to [GI-53, "Intermittent Incident"](#).

5. SEAT BELT BUCKLE SWITCH RH

1. Replace the seat belt buckle switch RH. Refer to [SR-30, "Removal and Installation"](#).
2. Turn ignition switch ON.
3. Check for DTC using CONSULT.

Is DTC still current?

- YES >> GO TO 6.
NO >> Clear DTC. Inspection End.

6. AIR BAG DIAGNOSIS SENSOR UNIT

1. Replace the air bag diagnosis sensor unit. Refer to [SR-27, "Removal and Installation"](#).
2. Turn ignition switch ON.
3. Check for DTC using CONSULT.

Is DTC still current?

- YES >> GO TO 7.
NO >> Clear DTC. Inspection End.

7. RELATED HARNESS

Replace the related harness.

>> END

B1430 SEAT BELT PRE-TENSIONER

< DTC/CIRCUIT DIAGNOSIS >

B1430 SEAT BELT PRE-TENSIONER

Description

INFOID:000000009764423

DTC B1430, B1432 SEAT BELT PRE-TENSIONER LH

The seat belt pre-tensioner LH is wired to the air bag diagnosis sensor unit. The air bag diagnosis sensor unit will monitor for opens and shorts in detected lines to the seat belt pre-tensioner LH.

PART LOCATION

Refer to [SRC-5, "Component Parts Location"](#).

DTC Logic

INFOID:000000009764424

With CONSULT

CONSULT name	DTC	DTC detecting condition	Repair order
FRONT PRE-TEN LH CIRCUIT [OPEN]	B1430	LH seat belt pre-tensioner circuit is open. (shoulder belt)	Refer to SRC-91, "Diagnosis Procedure" .
FRONT PRE-TEN LH CIRCUIT [VB-SHORT]		LH seat belt pre-tensioner circuit is shorted to a power supply circuit. (shoulder belt)	
FRONT PRE-TEN LH CIRCUIT [GND-SHORT]		LH seat belt pre-tensioner circuit is shorted to ground. (shoulder belt)	
FRONT PRE-TEN LH CIRCUIT [SHORT]		LH seat belt pre-tensioner circuits are shorted to each other. (shoulder belt)	

DTC CONFIRMATION PROCEDURE (With CONSULT)

1. CHECK SELF-DIAG RESULT

- Turn ignition switch ON.
- Check for DTC using CONSULT.

Is the DTC detected?

YES (Current DTC)>>Refer to [SRC-91, "Diagnosis Procedure"](#).

YES (Past DTC)>>GO TO 2.

NO >> Inspection End.

2. ERASE SELF-DIAG RESULT

Erase the DTC using CONSULT.

Can the DTC be erased?

YES >> Inspection End.

NO >> Refer to [SRC-91, "Diagnosis Procedure"](#).

DTC CONFIRMATION PROCEDURE (Without CONSULT)

1. CHECK SELF-DIAG RESULT

- Turn ignition switch ON.
- Check the air bag warning lamp status. Refer to [SRC-17, "Trouble Diagnosis without CONSULT"](#).

NOTE:

SRS will not enter diagnosis mode if no malfunction is detected in user mode.

Is the DTC detected?

YES >> Refer to [SRC-91, "Diagnosis Procedure"](#).

NO >> Inspection End.

Diagnosis Procedure

INFOID:000000009764425

1. HARNESS CONNECTOR

Visually inspect all applicable harness connectors for the following:

- Visible damage to connector or terminal

B1430 SEAT BELT PRE-TENSIONER

< DTC/CIRCUIT DIAGNOSIS >

- Loose terminal
- Poor connection

NOTE:

All harness connectors should be inspected from the air bag diagnosis sensor unit to the end component (including any in-line connectors).

Is the inspection result normal?

YES >> GO TO 2.

- NO >> Perform one of the following repairs:
- Visible damage: Replace the harness.
 - Loose terminal: Secure the terminal.
 - Poor connection: Secure the connection.

2. CONFIRM DTC

1. Reconnect all harness connectors.
2. Turn ignition switch ON.
3. Check for DTC using CONSULT.

Is DTC still current?

YES >> GO TO 3.

NO >> Refer to [GI-53, "Intermittent Incident"](#).

3. WIRING HARNESS

Check the wiring harness for visible damage.

NOTE:

The entire wiring harness should be inspected from the air bag diagnosis sensor unit to the end component (including any in-line connectors).

Is the inspection result normal?

YES >> GO TO 4.

NO >> Replace the harness.

4. CONFIRM DTC

1. Reconnect all harness connectors.
2. Turn ignition switch ON.
3. Check for DTC using CONSULT.

Is DTC still current?

YES >> GO TO 5.

NO >> Refer to [GI-53, "Intermittent Incident"](#).

5. AIR BAG DIAGNOSIS SENSOR UNIT

1. Replace the air bag diagnosis sensor unit. Refer to [SR-27, "Removal and Installation"](#).
2. Turn ignition switch ON.
3. Check for DTC using CONSULT.

Is DTC still current?

YES >> GO TO 6.

NO >> Clear DTC. Inspection End.

6. SEAT BELT PRE-TENSIONER LH

1. Replace the seat belt pre-tensioner LH. Refer to [SR-29, "Removal and Installation"](#).
2. Turn ignition switch ON.
3. Check for DTC using CONSULT.

Is DTC still current?

YES >> GO TO 7.

NO >> Clear DTC. Inspection End.

7. RELATED HARNESS

Replace the related harness.

>> END

B1431 SEAT BELT PRE-TENSIONER

< DTC/CIRCUIT DIAGNOSIS >

B1431 SEAT BELT PRE-TENSIONER

Description

INFOID:000000009764426

DTC B1431, B1433 SEAT BELT PRE-TENSIONER RH

The seat belt pre-tensioner RH is wired to the air bag diagnosis sensor unit. The air bag diagnosis sensor unit will monitor for opens and shorts in detected lines to the seat belt pre-tensioner RH.

PART LOCATION

Refer to [SRC-5, "Component Parts Location"](#).

DTC Logic

INFOID:000000009764427

With CONSULT

CONSULT name	DTC	DTC detecting condition	Repair order
FRONT PRE-TEN RH CIRCUIT [OPEN]	B1431	RH seat belt pre-tensioner circuit is open. (shoulder belt)	Refer to SRC-93, "Diagnosis Procedure" .
FRONT PRE-TEN RH CIRCUIT [VB-SHORT]		RH seat belt pre-tensioner circuit is shorted to a power supply circuit. (shoulder belt)	
FRONT PRE-TEN RH CIRCUIT [GND-SHORT]		RH seat belt pre-tensioner circuit is shorted to ground. (shoulder belt)	
FRONT PRE-TEN RH CIRCUIT [SHORT]		RH seat belt pre-tensioner circuits are shorted to each other. (shoulder belt)	

DTC CONFIRMATION PROCEDURE (With CONSULT)

1.CHECK SELF-DIAG RESULT

- Turn ignition switch ON.
- Check for DTC using CONSULT.

Is the DTC detected?

YES (Current DTC)>>Refer to [SRC-93, "Diagnosis Procedure"](#).

YES (Past DTC)>>GO TO 2.

NO >> Inspection End.

2.ERASE SELF-DIAG RESULT

Erase the DTC using CONSULT.

Can the DTC be erased?

YES >> Inspection End.

NO >> Refer to [SRC-93, "Diagnosis Procedure"](#).

DTC CONFIRMATION PROCEDURE (Without CONSULT)

1.CHECK SELF-DIAG RESULT

- Turn ignition switch ON.
- Check the air bag warning lamp status. Refer to [SRC-17, "Trouble Diagnosis without CONSULT"](#).

NOTE:

SRS will not enter diagnosis mode if no malfunction is detected in user mode.

Is the DTC detected?

YES >> Refer to [SRC-93, "Diagnosis Procedure"](#).

NO >> Inspection End.

Diagnosis Procedure

INFOID:000000009764428

1.HARNES CONNECTOR

Visually inspect all applicable harness connectors for the following:

- Visible damage to connector or terminal

B1431 SEAT BELT PRE-TENSIONER

< DTC/CIRCUIT DIAGNOSIS >

- Loose terminal
- Poor connection

NOTE:

All harness connectors should be inspected from the air bag diagnosis sensor unit to the end component (including any in-line connectors).

Is the inspection result normal?

YES >> GO TO 2.

- NO >> Perform one of the following repairs:
- Visible damage: Replace the harness.
 - Loose terminal: Secure the terminal.
 - Poor connection: Secure the connection.

2. CONFIRM DTC

1. Reconnect all harness connectors.
2. Turn ignition switch ON.
3. Check for DTC using CONSULT.

Is DTC still current?

YES >> GO TO 3.

NO >> Refer to [GI-53, "Intermittent Incident"](#).

3. WIRING HARNESS

Check the wiring harness for visible damage.

NOTE:

The entire wiring harness should be inspected from the air bag diagnosis sensor unit to the end component (including any in-line connectors).

Is the inspection result normal?

YES >> GO TO 4.

NO >> Replace the harness.

4. CONFIRM DTC

1. Reconnect all harness connectors.
2. Turn ignition switch ON.
3. Check for DTC using CONSULT.

Is DTC still current?

YES >> GO TO 5.

NO >> Refer to [GI-53, "Intermittent Incident"](#).

5. AIR BAG DIAGNOSIS SENSOR UNIT

1. Replace the air bag diagnosis sensor unit. Refer to [SR-27, "Removal and Installation"](#).
2. Turn ignition switch ON.
3. Check for DTC using CONSULT.

Is DTC still current?

YES >> GO TO 6.

NO >> Clear DTC. Inspection End.

6. SEAT BELT PRE-TENSIONER RH

1. Replace the seat belt pre-tensioner RH. Refer to [SR-29, "Removal and Installation"](#).
2. Turn ignition switch ON.
3. Check for DTC using CONSULT.

Is DTC still current?

YES >> GO TO 7.

NO >> Clear DTC. Inspection End.

7. RELATED HARNESS

Replace the related harness.

>> END

B1432 LAP PRE-TENSIONER

< DTC/CIRCUIT DIAGNOSIS >

B1432 LAP PRE-TENSIONER

DTC Logic

INFOID:000000009764429

With CONSULT

CONSULT name	DTC detecting condition	Repair order
Front PRE-TEN FRONT LH 2 [OPEN]	Lap pre-tensioner LH circuit is open	Refer to SRC-95, "Diagnosis Procedure" .
Front PRE-TEN FRONT LH 2 [VB-SHORT]	Lap pre-tensioner LH circuit is shorted to power supply circuit	
Front PRE-TEN FRONT LH 2 [GND-SHORT]	Lap pre-tensioner LH circuit is shorted to ground	
Front PRE-TEN FRONT LH 2 [SHORT]	Lap pre-tensioner LH circuits are shorted to each other	

DTC CONFIRMATION PROCEDURE (With CONSULT)

1. CHECK SELF-DIAG RESULT

1. Turn ignition switch ON.
2. Check for DTC using CONSULT.

Is the DTC detected?

YES (Current DTC)>>Refer to [SRC-95, "Diagnosis Procedure"](#).

YES (Past DTC)>>GO TO 2.

NO >> Inspection End.

2. ERASE SELF-DIAG RESULT

Erase the DTC using CONSULT.

Can the DTC be erased?

YES >> Inspection End.

NO >> Refer to [SRC-95, "Diagnosis Procedure"](#).

DTC CONFIRMATION PROCEDURE (Without CONSULT)

1. CHECK SELF-DIAG RESULT

1. Turn ignition switch ON.
2. Check the air bag warning lamp status. Refer to [SRC-17, "Trouble Diagnosis without CONSULT"](#).

NOTE:

SRS will not enter diagnosis mode if no malfunction is detected in user mode.

Is the DTC detected?

YES >> Refer to [SRC-95, "Diagnosis Procedure"](#).

NO >> Inspection End.

Diagnosis Procedure

INFOID:000000009764430

1. HARNESS CONNECTOR

Visually inspect all applicable harness connectors for the following:

- Visible damage to connector or terminal
- Loose terminal
- Poor connection

NOTE:

All harness connectors should be inspected from the air bag diagnosis sensor unit to the end component (including any in-line connectors).

Is the inspection result normal?

YES >> GO TO 2.

NO >> Perform one of the following repairs:

- Visible damage: Replace the harness.

B1432 LAP PRE-TENSIONER

< DTC/CIRCUIT DIAGNOSIS >

- Loose terminal: Secure the terminal.
- Poor connection: Secure the connection.

2. CONFIRM DTC

1. Reconnect all harness connectors.
2. Turn ignition switch ON.
3. Check for DTC using CONSULT.

Is DTC still current?

- YES >> GO TO 3.
NO >> Refer to [GI-53, "Intermittent Incident"](#).

3. WIRING HARNESS

Check the wiring harness for visible damage.

NOTE:

The entire wiring harness should be inspected from the air bag diagnosis sensor unit to the end component (including any in-line connectors).

Is the inspection result normal?

- YES >> GO TO 4.
NO >> Replace the harness.

4. CONFIRM DTC

1. Reconnect all harness connectors.
2. Turn ignition switch ON.
3. Check for DTC using CONSULT.

Is DTC still current?

- YES >> GO TO 5.
NO >> Refer to [GI-53, "Intermittent Incident"](#).

5. AIR BAG DIAGNOSIS SENSOR UNIT

1. Replace the air bag diagnosis sensor unit. Refer to [SR-27, "Removal and Installation"](#).
2. Turn ignition switch ON.
3. Check for DTC using CONSULT.

Is DTC still current?

- YES >> GO TO 6.
NO >> Clear DTC. Inspection End.

6. LAP PRE-TENSIONER LH

1. Replace the lap pre-tensioner LH. Refer to [SR-29, "Removal and Installation"](#).
2. Turn ignition switch ON.
3. Check for DTC using CONSULT.

Is DTC still current?

- YES >> GO TO 7.
NO >> Clear DTC. Inspection End.

7. RELATED HARNESS

Replace the related harness.

>> **END**

B1433 LAP PRE-TENSIONER

< DTC/CIRCUIT DIAGNOSIS >

B1433 LAP PRE-TENSIONER

DTC Logic

INFOID:000000009764431

With CONSULT

CONSULT name		DTC detecting condition	Repair order
PRE-TEN FRONT RH 2 [OPEN]	B1433	Lap pre-tensioner RH circuit is open	Refer to SRC-97, "Diagnosis Procedure" .
PRE-TEN FRONT RH 2 [VB-SHORT]		Lap pre-tensioner RH circuit is shorted to power supply circuit	
PRE-TEN FRONT RH 2 [GND-SHORT]		Lap pre-tensioner RH circuit is shorted to ground	
PRE-TEN FRONT RH 2 [SHORT]		Lap pre-tensioner RH circuits are shorted to each other	

DTC CONFIRMATION PROCEDURE (With CONSULT)

1. CHECK SELF-DIAG RESULT

1. Turn ignition switch ON.
2. Check for DTC using CONSULT.

Is the DTC detected?

YES (Current DTC)>>Refer to [SRC-97, "Diagnosis Procedure"](#).

YES (Past DTC)>>GO TO 2.

NO >> Inspection End.

2. ERASE SELF-DIAG RESULT

Erase the DTC using CONSULT.

Can the DTC be erased?

YES >> Inspection End.

NO >> Refer to [SRC-97, "Diagnosis Procedure"](#).

DTC CONFIRMATION PROCEDURE (Without CONSULT)

1. CHECK SELF-DIAG RESULT

1. Turn ignition switch ON.
2. Check the air bag warning lamp status. Refer to [SRC-17, "Trouble Diagnosis without CONSULT"](#).

NOTE:

SRS will not enter diagnosis mode if no malfunction is detected in user mode.

Is the DTC detected?

YES >> Refer to [SRC-97, "Diagnosis Procedure"](#).

NO >> Inspection End.

Diagnosis Procedure

INFOID:000000009764432

1. HARNESS CONNECTOR

Visually inspect all applicable harness connectors for the following:

- Visible damage to connector or terminal
- Loose terminal
- Poor connection

NOTE:

All harness connectors should be inspected from the air bag diagnosis sensor unit to the end component (including any in-line connectors).

Is the inspection result normal?

YES >> GO TO 2.

NO >> Perform one of the following repairs:

- Visible damage: Replace the harness.

B1433 LAP PRE-TENSIONER

< DTC/CIRCUIT DIAGNOSIS >

- Loose terminal: Secure the terminal.
- Poor connection: Secure the connection.

2. CONFIRM DTC

1. Reconnect all harness connectors.
2. Turn ignition switch ON.
3. Check for DTC using CONSULT.

Is DTC still current?

- YES >> GO TO 3.
NO >> Refer to [GI-53, "Intermittent Incident"](#).

3. WIRING HARNESS

Check the wiring harness for visible damage.

NOTE:

The entire wiring harness should be inspected from the air bag diagnosis sensor unit to the end component (including any in-line connectors).

Is the inspection result normal?

- YES >> GO TO 4.
NO >> Replace the harness.

4. CONFIRM DTC

1. Reconnect all harness connectors.
2. Turn ignition switch ON.
3. Check for DTC using CONSULT.

Is DTC still current?

- YES >> GO TO 5.
NO >> Refer to [GI-53, "Intermittent Incident"](#).

5. AIR BAG DIAGNOSIS SENSOR UNIT

1. Replace the air bag diagnosis sensor unit. Refer to [SR-27, "Removal and Installation"](#).
2. Turn ignition switch ON.
3. Check for DTC using CONSULT.

Is DTC still current?

- YES >> GO TO 6.
NO >> Clear DTC. Inspection End.

6. LAP PRE-TENSIONER RH

1. Replace the lap pre-tensioner RH. Refer to [SR-29, "Removal and Installation"](#).
2. Turn ignition switch ON.
3. Check for DTC using CONSULT.

Is DTC still current?

- YES >> GO TO 7.
NO >> Clear DTC. Inspection End.

7. RELATED HARNESS

Replace the related harness.

>> **END**

B1436 ACTIVE VENT

< DTC/CIRCUIT DIAGNOSIS >

B1436 ACTIVE VENT

DTC Logic

INFOID:000000009764433

With CONSULT

CONSULT name		DTC detecting condition	Repair order
ACTIVE VENT [OPEN]	B1436	Active vent circuit is open	Refer to SRC-99, "Diagnosis Procedure" .
ACTIVE VENT [VB-SHORT]		Active vent circuit is shorted to power supply circuit	
ACTIVE VENT [GND-SHORT]		Active vent circuit is shorted to ground	
ACTIVE VENT [SHORT]		Active vent circuit is shorted to each other	

DTC CONFIRMATION PROCEDURE (With CONSULT)

1. CHECK SELF-DIAG RESULT

- Turn ignition switch ON.
- Check for DTC using CONSULT.

Is the DTC detected?

YES (Current DTC)>>Refer to [SRC-99, "Diagnosis Procedure"](#).

YES (Past DTC)>>GO TO 2.

NO >> Inspection End.

2. ERASE SELF-DIAG RESULT

Erase the DTC using CONSULT.

Can the DTC be erased?

YES >> Inspection End.

NO >> Refer to [SRC-99, "Diagnosis Procedure"](#).

DTC CONFIRMATION PROCEDURE (Without CONSULT)

1. CHECK SELF-DIAG RESULT

- Turn ignition switch ON.
- Check the air bag warning lamp status. Refer to [SRC-17, "Trouble Diagnosis without CONSULT"](#).

NOTE:

SRS will not enter diagnosis mode if no malfunction is detected in user mode.

Is the DTC detected?

YES >> Refer to [SRC-99, "Diagnosis Procedure"](#).

NO >> Inspection End.

Diagnosis Procedure

INFOID:000000009764434

1. HARNESS CONNECTOR

Visually inspect all applicable harness connectors for the following:

- Visible damage to connector or terminal
- Loose terminal
- Poor connection

NOTE:

All harness connectors should be inspected from the air bag diagnosis unit to the end component (including any in-line connectors).

Is the inspection result normal?

YES >> GO TO 2.

- NO >> Perform one of the following repairs:
- Visible damage: Replace the harness.

B1436 ACTIVE VENT

< DTC/CIRCUIT DIAGNOSIS >

- Loose terminal: Secure the terminal.
- Poor connection: Secure the connection.

2. CONFIRM DTC

1. Reconnect all harness connectors.
2. Turn ignition switch ON.
3. Check for DTC using CONSULT.

Is DTC still current?

- YES >> GO TO 3.
NO >> Refer to [GI-53, "Intermittent Incident"](#).

3. WIRING HARNESS

Check the wiring harness for visible damage.

NOTE:

The entire wiring harness should be inspected from the air bag diagnosis sensor unit to the end component (including any in-line connectors).

Is the inspection result normal?

- YES >> GO TO 4.
NO >> Replace the harness.

4. CONFIRM DTC

1. Reconnect all harness connectors.
2. Turn ignition switch ON.
3. Check for DTC using CONSULT.

Is DTC still current?

- YES >> GO TO 5.
NO >> Refer to [GI-53, "Intermittent Incident"](#).

5. AIR BAG DIAGNOSIS SENSOR UNIT

1. Replace the air bag diagnosis sensor unit. Refer to [SR-27, "Removal and Installation"](#).
2. Turn ignition switch ON.
3. Check for DTC using CONSULT.

Is DTC still current?

- YES >> GO TO 6.
NO >> Clear DTC. Inspection End.

6. FRONT PASSENGER AIR BAG MODULE

1. Replace the front passenger air bag module. Refer to [SR-18, "Removal and Installation"](#).
2. Turn ignition switch ON.
3. Check for DTC using CONSULT.

Is DTC still current?

- YES >> GO TO 7.
NO >> Clear DTC. Inspection End.

7. RELATED HARNESS

Replace the related harness.

>> **END**

B142A IGNITION VOLTAGE

< DTC/CIRCUIT DIAGNOSIS >

B142A IGNITION VOLTAGE

Description

INFOID:000000009764435

DTC B142A IGNITION VOLTAGE

Ignition voltage is supplied to the air bag diagnosis sensor unit when the ignition is in the ON position. The air bag diagnosis sensor unit will monitor for low or high ignition voltage.

PART LOCATION

Refer to [SRC-5, "Component Parts Location"](#).

DTC Logic

INFOID:000000009764436

DTC DETECTION LOGIC

With CONSULT

CONSULT name	DTC	DTC detecting condition	Repair order
IGN VOLTAGE [LOW]	B142A	Ignition voltage low at air bag diagnosis sensor unit.	Refer to SRC-101, "Diagnosis Procedure" .
IGN VOLTAGE [HIGH]		Ignition voltage high at air bag diagnosis sensor unit.	

DTC CONFIRMATION PROCEDURE (With CONSULT)

SRC

1. CHECK SELF-DIAG RESULT

- Turn ignition switch ON.
- Check for DTC using CONSULT.

Is the DTC detected?

YES (Current DTC)>>Refer to [SRC-101, "Diagnosis Procedure"](#).

YES (Past DTC)>>GO TO 2.

NO >> Inspection End.

2. ERASE SELF-DIAG RESULT

Erase the DTC using CONSULT.

Can the DTC be erased?

YES >> Inspection End.

NO >> Refer to [SRC-101, "Diagnosis Procedure"](#).

DTC CONFIRMATION PROCEDURE (Without CONSULT)

1. CHECK SELF-DIAG RESULT

- Turn ignition switch ON.
- Check the air bag warning lamp status. Refer to [SRC-17, "Trouble Diagnosis without CONSULT"](#).

NOTE:

SRS will not enter diagnosis mode if no malfunction is detected in user mode.

Is the DTC detected?

YES >> Refer to [SRC-101, "Diagnosis Procedure"](#).

NO >> Inspection End.

Diagnosis Procedure

INFOID:000000009764437

1. HARNESS CONNECTOR

Visually inspect all applicable harness connectors for the following:

- Visible damage to connector or terminal
- Loose terminal
- Poor connection

B142A IGNITION VOLTAGE

< DTC/CIRCUIT DIAGNOSIS >

NOTE:

All harness connectors should be inspected from the air bag diagnosis unit to the end component (including any in-line connectors).

Is the inspection result normal?

YES >> GO TO 2.

NO >> Perform one of the following repairs:

- Visible damage: Replace the harness.
- Loose terminal: Secure the terminal.
- Poor connection: Secure the connection.

2. CONFIRM DTC

1. Reconnect all harness connectors.
2. Turn ignition switch ON.
3. Check for DTC using CONSULT.

Is DTC still current?

YES >> GO TO 3

NO >> Refer to [GI-53, "Intermittent Incident"](#).

3. WIRING HARNESS

Check the wiring harness for visible damage.

NOTE:

The entire wiring harness should be inspected from the air bag diagnosis sensor unit to the end component (including any in-line connectors).

Is the inspection result normal?

YES >> GO TO 4.

NO >> Replace the harness.

4. CONFIRM DTC

1. Reconnect all harness connectors.
2. Turn ignition switch ON.
3. Check for DTC using CONSULT.

Is DTC still current?

YES >> GO TO 5.

NO >> Refer to [GI-53, "Intermittent Incident"](#).

5. AIR BAG DIAGNOSIS SENSOR UNIT

1. Replace the air bag diagnosis sensor unit. Refer to [SR-27, "Removal and Installation"](#).
2. Turn ignition switch ON.
3. Check for DTC using CONSULT.

Is DTC still current?

YES >> GO TO 6.

NO >> Clear DTC. Inspection End.

6. RELATED HARNESS

Replace the related harness.

>> **END**

B142X COLLISION DETECTION

< DTC/CIRCUIT DIAGNOSIS >

B142X COLLISION DETECTION

Description

INFOID:000000009764438

DTC B142X COLLISION DETECTION

The air bag diagnosis sensor unit will set this DTC if it has detected a collision which has resulted in a deployment of one or more air bags or pre-tensioners. If this DTC is detected after a SRS repair, the air bag diagnosis sensor unit has not yet been replaced. This DTC can not be erased.

PART LOCATION

Refer to [SRC-5, "Component Parts Location"](#).

DTC Logic

INFOID:000000009764439

With CONSULT

CONSULT name	DTC	DTC detecting condition	Repair order
FRONTAL COLLISION DETECTION	B1421	Frontal collision detected. Driver and/or front passenger air bag modules are deployed.	Refer to SR-5, "For Frontal Collision" .
SIDE COLLISION DETECTION	B1422	Side collision detected. Curtain air bag module and seat belt pre-tensioner are deployed.	Refer to SR-7, "For Side and Rollover Collision" .

DTC CONFIRMATION PROCEDURE (With CONSULT)

1.INSPECTION START

Turn ignition switch ON.

>> GO TO 2.

2.CHECK SELF-DIAG RESULT

Check for the DTC on CONSULT.

Is the DTC detected?

YES >> Refer to [SRC-103, "Diagnosis Procedure"](#).

NO >> Inspection End.

Diagnosis Procedure

INFOID:000000009764440

Refer to [SR-5, "For Frontal Collision"](#) or [SR-7, "For Side and Rollover Collision"](#).

A
B
C
D
E
F
G
I
J
K
L
M
N
O
P

SRC

B14XX AIR BAG DIAGNOSIS SENSOR UNIT

< DTC/CIRCUIT DIAGNOSIS >

B14XX AIR BAG DIAGNOSIS SENSOR UNIT

Description

INFOID:000000009764441

DTC B14XX AIR BAG DIAGNOSIS SENSOR UNIT

The air bag diagnosis sensor unit will run self diagnostics when the ignition switch is turned ON. It has the potential to set many diagnostic trouble codes which will conform to the B14XX format, but will not match any other SRS diagnostic trouble codes. Refer to [SRC-17, "CONSULT Function \(AIR BAG\)"](#).

PART LOCATION

Refer to [SRC-5, "Component Parts Location"](#).

DTC Logic

INFOID:000000009764442

With CONSULT

CONSULT name	DTC	DTC detecting condition	Repair order
CONTROL UNIT [UNIT FAIL]	B14XX	Air bag diagnosis sensor unit is malfunctioning.	Refer to SRC-104, "Diagnosis Procedure" .
AIRBAG DISPOSAL COMPLETION			

DTC CONFIRMATION PROCEDURE (With CONSULT)

1.CHECK SELF-DIAG RESULT

1. Turn ignition switch ON.
2. Check for DTC using CONSULT.

Is the DTC detected?

YES (Current DTC)>>Refer to [SRC-104, "Diagnosis Procedure"](#).
YES (Past DTC)>>GO TO 2.
NO >> Inspection End.

2.ERASE SELF-DIAG RESULT

Erase the DTC using CONSULT.

Can the DTC be erased?

YES >> Inspection End.
NO >> Refer to [SRC-104, "Diagnosis Procedure"](#).

DTC CONFIRMATION PROCEDURE (Without CONSULT)

1.CHECK SELF-DIAG RESULT

1. Turn ignition switch ON.
2. Check the air bag warning lamp status. Refer to [SRC-17, "Trouble Diagnosis without CONSULT"](#).

NOTE:

SRS will not enter diagnosis mode if no malfunction is detected in user mode.

Is the DTC detected?

YES >> Refer to [SRC-104, "Diagnosis Procedure"](#).
NO >> Inspection End.

Diagnosis Procedure

INFOID:000000009764443

1.HARNES CONNECTOR

Visually inspect all applicable harness connectors for the following:

- Visible damage to connector or terminal
- Loose terminal
- Poor connection

NOTE:

B14XX AIR BAG DIAGNOSIS SENSOR UNIT

< DTC/CIRCUIT DIAGNOSIS >

All harness connectors should be inspected from the air bag diagnosis sensor unit to the end component (including any in-line connectors).

Is the inspection result normal?

YES >> GO TO 2.

NO >> Perform one of the following repairs:

- Visible damage: Replace the harness.
- Loose terminal: Secure the terminal.
- Poor connection: Secure the connection.

2.CONFIRM DTC

1. Reconnect all harness connectors.
2. Turn ignition switch ON.
3. Check for DTC using CONSULT.

Is DTC still current?

YES >> GO TO 3.

NO >> Refer to [GI-53, "Intermittent Incident"](#).

3.WIRING HARNESS

Check the wiring harness for visible damage.

NOTE:

The entire wiring harness should be inspected from the air bag diagnosis sensor unit to the end component (including any in-line connectors).

Is the inspection result normal?

YES >> GO TO 4.

NO >> Replace the harness.

4.CONFIRM DTC

1. Reconnect all harness connectors.
2. Turn ignition switch ON.
3. Check for DTC using CONSULT.

Is DTC still current?

YES >> GO TO 5.

NO >> Refer to [GI-53, "Intermittent Incident"](#).

5.AIR BAG DIAGNOSIS SENSOR UNIT

1. Replace the air bag diagnosis sensor unit. Refer to [SR-27, "Removal and Installation"](#).
2. Turn ignition switch ON.
3. Check for DTC using CONSULT.

Is DTC still current?

YES >> GO TO 6.

NO >> Clear DTC. Inspection End.

6.RELATED HARNESS

Replace the related harness.

>> **END**

A

B

C

D

E

F

G

SRC

I

J

K

L

M

N

O

P

SRS AIR BAG WARNING LAMP DOES NOT TURN ON

< SYMPTOM DIAGNOSIS >

SYMPTOM DIAGNOSIS

SRS AIR BAG WARNING LAMP DOES NOT TURN ON

AIR BAG Warning Lamp Does Not Turn On

INFOID:000000009134448

1. CHECK METER FUSE

Check the 10A fuse [No. 13, located in the fuse block (J/B)].

Is the fuse blown?

YES >> GO TO 2.

NO >> GO TO 3.

2. REPLACE METER FUSE AND CHECK AGAIN

Replace 10A fuse [No. 13, located in the fuse block (J/B)] and turn ignition switch ON.

Does the fuse blow again?

YES >> Replace fuse and harness.

NO >> Inspection End.

3. CHECK HARNESS CONNECTIONS BETWEEN AIR BAG DIAGNOSIS SENSOR UNIT AND COMBINATION METER

Inspect the harness and connectors between the air bag diagnosis sensor unit and the combination meter.

Do the harness or connectors have any visible damage?

YES >> Replace harness.

NO >> GO TO 4.

4. CHECK COMBINATION METER

Disconnect the air bag diagnosis sensor unit harness connectors and turn ignition switch ON.

Does AIR BAG warning lamp turn on?

YES >> Replace the air bag diagnosis sensor unit. Refer to [SR-27. "Removal and Installation"](#).

NO >> Replace the combination meter. Refer to [MWI-95. "Removal and Installation"](#).

SRS AIR BAG WARNING LAMP DOES NOT TURN OFF

< SYMPTOM DIAGNOSIS >

SRS AIR BAG WARNING LAMP DOES NOT TURN OFF

AIR BAG Warning Lamp Does Not Turn Off

INFOID:000000009134449

1. CHECK CONDITION OF AIR BAG MODULE

Inspect for any deployed air bag modules or seat belt pre-tensioners.

Are any air bag modules or seat belt pre-tensioners deployed?

- YES >> Refer to [SR-5. "For Frontal Collision"](#) or [SR-7. "For Side and Rollover Collision"](#).
- NO >> GO TO 2.

2. CHECK THE AIR BAG FUSE

Check 10A fuse [No. 32, located in the fuse block (J/B)].

Is the fuse blown?

- YES >> GO TO 3.
- NO >> GO TO 4.

3. CHECK AIR BAG FUSE AGAIN

Replace 10A fuse [No. 32, located in the fuse block (J/B)] and turn ignition switch ON.

Does the fuse blow again?

- YES >> Replace fuse and harness.
- NO >> Inspection End.

4. CHECK AIR BAG DIAGNOSIS SENSOR UNIT

Connect CONSULT.

Is "AIR BAG" displayed on CONSULT?

- YES >> GO TO 5.
- NO >> Visually inspect the air bag diagnosis sensor unit harness connections. If the connections are OK, replace the air bag diagnosis sensor unit. Refer to [SR-27. "Removal and Installation"](#).

5. CHECK HARNESS CONNECTION

Check for loose connections between the combination meter and the air bag diagnosis sensor unit.

Are there any loose connections?

- YES >> Properly connect the combination meter and air bag diagnosis sensor unit harness connectors. If AIR BAG warning lamp still does not turn off, replace the wiring harness.
- NO >> Replace air bag diagnosis sensor unit. Refer to [SR-27. "Removal and Installation"](#).

SEAT BELT WARNING SYSTEM

< SYMPTOM DIAGNOSIS >

SEAT BELT WARNING SYSTEM

Seat Belt Warning System Does Not Function

INFOID:000000009134450

1. SEAT BELT WARNING LIGHT

Turn ignition switch ON.

Does the seat belt warning lamp come ON?

YES >> GO TO 2.

- NO >>
- Check 10A fuse [No. 13, located in the fuse block (J/B)].
 - Check seat belt buckle switch (driver seat).
 - Check harness between combination meter and seat belt buckle switch (driver seat).
 - Check combination meter. Refer to [MWI-26, "Fail-Safe"](#).

2. SEAT BELT BUCKLE (DRIVER SEAT)

Fasten the seat belt buckle (driver seat).

Does the seat belt warning lamp go OFF?

YES >> GO TO 3.

- NO >>
- Check seat belt buckle switch (driver seat).
 - Check harness between combination meter and seat belt buckle switch (driver seat).

3. OCCUPANT CLASSIFICATION SYSTEM

Have a helper sit in the passenger seat.

Does the seat belt warning lamp go ON?

YES >> GO TO 4.

- NO >>
- Check occupant classification system. Refer to [SRC-12, "OCCUPANT CLASSIFICATION SYSTEM: System Description"](#).
 - Check harness between occupant classification control unit and air bag diagnosis sensor unit.

4. SEAT BELT BUCKLE (PASSENGER SEAT)

Fasten the seat belt buckle (passenger seat).

Does the seat belt warning lamp go OFF?

YES >> System OK.

- NO >>
- Check seat belt buckle switch (passenger seat).
 - Check harness between seat belt buckle switch (passenger seat) and air bag diagnosis sensor unit.
 - Replace air bag diagnosis sensor unit. Refer to [SR-27, "Removal and Installation"](#).