

SECTION **CCS**

CRUISE CONTROL SYSTEM

A
B
C
D
E
F
G
H
I
J
K
L
M
N
P

CONTENTS

<p>ICC</p> <p>PRECAUTION 6</p> <p>PRECAUTIONS 6</p> <p style="padding-left: 20px;">Precaution for Supplemental Restraint System (SRS) "AIR BAG" and "SEAT BELT PRE-TENSIONER" 6</p> <p style="padding-left: 20px;">Precautions For Harness Repair 6</p> <p style="padding-left: 20px;">ICC System Service 7</p> <p>PREPARATION 8</p> <p>PREPARATION 8</p> <p style="padding-left: 20px;">Special Service Tools 8</p> <p>SYSTEM DESCRIPTION 9</p> <p>COMPONENT PARTS 9</p> <p style="padding-left: 20px;">Component Parts Location 9</p> <p style="padding-left: 20px;">ICC Sensor 11</p> <p style="padding-left: 20px;">ADAS Control Unit 11</p> <p style="padding-left: 20px;">Brake Pedal Position Switch/Stop Lamp Switch 12</p> <p style="padding-left: 20px;">ICC Steering Switch 12</p> <p style="padding-left: 20px;">ICC Brake Hold Relay 12</p> <p style="padding-left: 20px;">Combination Meter 13</p> <p>SYSTEM 14</p> <p style="padding-left: 20px;">System Description 14</p> <p style="padding-left: 20px;">Circuit Diagram 18</p> <p style="padding-left: 20px;">Fail-safe (ADAS Control Unit) 19</p> <p style="padding-left: 20px;">Fail-safe (ICC Sensor) 20</p> <p>VEHICLE-TO-VEHICLE DISTANCE CONTROL MODE FUNCTION 20</p> <p style="padding-left: 20px;">VEHICLE-TO-VEHICLE DISTANCE CONTROL MODE FUNCTION : System Description 20</p> <p>CONVENTIONAL (FIXED SPEED) CRUISE CONTROL MODE FUNCTION 23</p>	<p style="padding-left: 20px;">CONVENTIONAL (FIXED SPEED) CRUISE CONTROL MODE FUNCTION : System Description 23</p> <p>OPERATION 26</p> <p>VEHICLE-TO-VEHICLE DISTANCE CONTROL MODE FUNCTION 26</p> <p style="padding-left: 20px;">VEHICLE-TO-VEHICLE DISTANCE CONTROL MODE FUNCTION : Switch Name and Function 26</p> <p style="padding-left: 20px;">VEHICLE-TO-VEHICLE DISTANCE CONTROL MODE FUNCTION : Menu Displayed by Pressing Each Switch 26</p> <p>CONVENTIONAL (FIXED SPEED) CRUISE CONTROL MODE FUNCTION 29</p> <p style="padding-left: 20px;">CONVENTIONAL (FIXED SPEED) CRUISE CONTROL MODE FUNCTION : Switch Name and Function 29</p> <p style="padding-left: 20px;">CONVENTIONAL (FIXED SPEED) CRUISE CONTROL MODE FUNCTION : Menu Displayed by Pressing Each Switch 30</p> <p>HANDLING PRECAUTION 32</p> <p style="padding-left: 20px;">Precautions for Vehicle-to-Vehicle Distance Control Mode 32</p> <p style="padding-left: 20px;">Precautions for Conventional (Fixed Speed) Cruise Control Mode 34</p> <p>DIAGNOSIS SYSTEM (ADAS CONTROL UNIT) 35</p> <p style="padding-left: 20px;">On Board Diagnosis Function 35</p> <p style="padding-left: 20px;">CONSULT Function (ICC/ADAS) 36</p> <p>DIAGNOSIS SYSTEM (ICC SENSOR) 49</p> <p style="padding-left: 20px;">CONSULT Function (LASER/RADAR) 49</p> <p>ECU DIAGNOSIS INFORMATION 51</p> <p>ADAS CONTROL UNIT 51</p> <p style="padding-left: 20px;">Reference Value 51</p> <p style="padding-left: 20px;">Fail-safe 57</p>
---	---

CCS

DTC Inspection Priority Chart	58	ADAS CONTROL UNIT : DTC Logic	105
DTC Index	60	ADAS CONTROL UNIT : Diagnosis Procedure ...	105
ICC SENSOR	65	ICC SENSOR	105
Reference Value	65	ICC SENSOR : DTC Logic	105
Fail-safe	66	ICC SENSOR : Diagnosis Procedure	106
DTC Inspection Priority Chart	66	C1A03 VEHICLE SPEED SENSOR	107
DTC Index	66	DTC Logic	107
WIRING DIAGRAM	68	Diagnosis Procedure	107
INTELLIGENT CRUISE CONTROL	68	C1A04 ABS/TCS/VDC SYSTEM	109
Wiring Diagram	68	DTC Logic	109
BASIC INSPECTION	83	Diagnosis Procedure	109
DIAGNOSIS AND REPAIR WORK FLOW	83	C1A05 BRAKE SW/STOP LAMP SW	110
Work Flow	83	DTC Logic	110
ADDITIONAL SERVICE WHEN REPLACING		Diagnosis Procedure	110
ICC SENSOR	85	Component Inspection (Brake Pedal Position	
Description	85	Switch)	113
Work Procedure	85	Component Inspection (Stop Lamp Switch)	113
ICC SENSOR INITIAL VERTICAL ALIGN-		C1A06 OPERATION SW	114
MENT	86	DTC Logic	114
Description	86	Diagnosis Procedure	114
Required Tools	86	Component Inspection	115
Preparation	86	C1A12 LASER BEAM OFF CENTER	117
ICC Sensor Initial Vertical Alignment	87	DTC Logic	117
ICC SENSOR ALIGNMENT	89	Diagnosis Procedure	117
Description	89	C1A12 RADAR OFF-CENTER	118
Required Tools	89	DTC Logic	118
Preparation	90	Diagnosis Procedure	118
Vehicle Set Up	91	C1A13 STOP LAMP RELAY	119
Setting The ICC Target Board	93	DTC Logic	119
ICC Sensor Adjustment	94	Diagnosis Procedure	119
ACTION TEST	97	Component Inspection	124
Description	97	C1A14 ECM	125
Work Procedure (Vehicle-To-Vehicle Distance		DTC Logic	125
Control Mode)	97	Diagnosis Procedure	125
Work Procedure [Conventional (Fixed Speed)		C1A15 GEAR POSITION	126
Cruise Control Mode]	100	Description	126
DTC/CIRCUIT DIAGNOSIS	103	DTC Logic	126
C1A00 CONTROL UNIT	103	Diagnosis Procedure	126
ADAS CONTROL UNIT	103	C1A16 RADAR STAIN	128
ADAS CONTROL UNIT : DTC Logic	103	DTC Logic	128
ADAS CONTROL UNIT : Diagnosis Procedure ...	103	Diagnosis Procedure	128
ICC SENSOR	103	C1A17 ICC SENSOR	130
ICC SENSOR : DTC Logic	103	DTC Logic	130
ICC SENSOR : Diagnosis Procedure	103	Diagnosis Procedure	130
C1A01 POWER SUPPLY CIRCUIT 1, C1A02		C1A18 LASER AIMING INCMP	131
POWER SUPPLY CIRCUIT 2	105	DTC Logic	131
ADAS CONTROL UNIT	105	Diagnosis Procedure	131
		C1A18 RADAR ALIGNMENT INCOMPLETE ..	132

DTC Logic	132	DTC Logic	147	
Diagnosis Procedure	132	Diagnosis Procedure	147	A
C1A21 UNIT HIGH TEMP	133	C1F01 ACCELERATOR PEDAL ACTUATOR. 148		
ADAS CONTROL UNIT	133	DTC Logic	148	B
ADAS CONTROL UNIT : DTC Logic	133	Diagnosis Procedure	148	
ADAS CONTROL UNIT : Diagnosis Procedure ...	133	C1F02 ACCELERATOR PEDAL ACTUATOR. 149		
ICC SENSOR	133	DTC Logic	149	C
ICC SENSOR : DTC Logic	133	Diagnosis Procedure	149	
ICC SENSOR : Diagnosis Procedure	134	C1F05 ACCELERATOR PEDAL ACTUATOR		
C1A24 NP RANGE	135	POWER SUPPLY CIRCUIT	150	D
DTC Logic	135	DTC Logic	150	
Diagnosis Procedure	135	Diagnosis Procedure	150	E
C1A26 ECD MODE MALFUNCTION	137	C10B7 YAW RATE SENSOR	151	
DTC Logic	137	DTC Logic	151	F
Diagnosis Procedure	137	Diagnosis Procedure	151	
C1A27 ECD POWER SUPPLY CIRCUIT	138	U0104 ADAS CAN 1	152	
DTC Logic	138	DTC Logic	152	G
Diagnosis Procedure	138	Diagnosis Procedure	152	
C1A2A ICC SENSOR POWER SUPPLY CIR-		U0121 VDC CAN 2	153	
CUIT	139	ADAS CONTROL UNIT	153	H
DTC Logic	139	ADAS CONTROL UNIT : DTC Logic	153	
Diagnosis Procedure	139	ADAS CONTROL UNIT : Diagnosis Procedure ...	153	
C1A33 CAN TRANSMISSION ERROR	140	ICC SENSOR	153	I
DTC Logic	140	ICC SENSOR : DTC Logic	153	
Diagnosis Procedure	140	ICC SENSOR : Diagnosis Procedure	154	J
C1A34 COMMAND ERROR	141	U0126 STRG SEN CAN 1	155	
DTC Logic	141	ADAS CONTROL UNIT	155	K
Diagnosis Procedure	141	ADAS CONTROL UNIT : DTC Logic	155	
C1A35 ACCELERATOR PEDAL ACTUATOR. 142		ADAS CONTROL UNIT : Diagnosis Procedure ...	155	
DTC Logic	142	ICC SENSOR	155	L
Diagnosis Procedure	142	ICC SENSOR : DTC Logic	155	
C1A36 ACCELERATOR PEDAL ACTUATOR		ICC SENSOR : Diagnosis Procedure	156	
CAN COMM	143	U0235 ICC SENSOR CAN 1	157	M
DTC Logic	143	DTC Logic	157	
Diagnosis Procedure	143	Diagnosis Procedure	157	
C1A37 ACCELERATOR PEDAL ACTUATOR		U0401 ECM CAN 1	158	N
CAN 2	144	DTC Logic	158	
DTC Logic	144	Diagnosis Procedure	158	
Diagnosis Procedure	144	U0402 TCM CAN 1	159	
C1A38 ACCELERATOR PEDAL ACTUATOR		DTC Logic	159	
CAN 1	145	Diagnosis Procedure	159	
DTC Logic	145	U0405 ADAS CAN 2	160	
Diagnosis Procedure	145	DTC Logic	160	
C1A39 STEERING ANGLE SENSOR	146	Diagnosis Procedure	160	
DTC Logic	146	U0415 VDC CAN 1	161	
Diagnosis Procedure	146	ADAS CONTROL UNIT	161	
C1A50 ADAS CONTROL UNIT	147			

ADAS CONTROL UNIT : DTC Logic	161	Diagnosis Procedure	173
ADAS CONTROL UNIT : Diagnosis Procedure	161		
ICC SENSOR	161	U1514 STRG SEN CAN 3	174
ICC SENSOR : DTC Logic	161	DTC Logic	174
ICC SENSOR : Diagnosis Procedure	162	Diagnosis Procedure	174
U0428 STRG SEN CAN 2	163	U1515 ICC SENSOR CAN 3	175
ADAS CONTROL UNIT	163	DTC Logic	175
ADAS CONTROL UNIT : DTC Logic	163	Diagnosis Procedure	175
ADAS CONTROL UNIT : Diagnosis Procedure	163	U1517 ACCELERATOR PEDAL ACTUATOR	
ICC SENSOR	163	CAN 3	176
ICC SENSOR : DTC Logic	163	DTC Logic	176
ICC SENSOR : Diagnosis Procedure	164	Diagnosis Procedure	176
U1000 CAN COMM CIRCUIT	165	POWER SUPPLY AND GROUND CIRCUIT ...	177
ADAS CONTROL UNIT	165	ADAS CONTROL UNIT	177
ADAS CONTROL UNIT : Description	165	ADAS CONTROL UNIT : Diagnosis Procedure ...	177
ADAS CONTROL UNIT : DTC Logic	165	ICC SENSOR	177
ADAS CONTROL UNIT : Diagnosis Procedure	165	ICC SENSOR : Diagnosis Procedure	177
ICC SENSOR	165	SYMPTOM DIAGNOSIS	179
ICC SENSOR : Description	165	INTELLIGENT CRUISE CONTROL SYSTEM	
ICC SENSOR : DTC Logic	165	SYMPTOMS	179
ICC SENSOR : Diagnosis Procedure	166	Symptom Table	179
U1010 CONTROL UNIT (CAN)	167	MAIN SWITCH DOES NOT TURN ON, MAIN	
ADAS CONTROL UNIT	167	SWITCH DOES NOT TURN OFF	180
ADAS CONTROL UNIT : Description	167	Description	180
ADAS CONTROL UNIT : DTC Logic	167	Diagnosis Procedure	180
ADAS CONTROL UNIT : Diagnosis Procedure	167	ICC SYSTEM CANNOT BE SET (MAIN	
ICC SENSOR	167	SWITCH TURNS ON/OFF)	181
ICC SENSOR : Description	167	Description	181
ICC SENSOR : DTC Logic	167	Diagnosis Procedure	181
ICC SENSOR : Diagnosis Procedure	167	ICC STEERING SWITCH (OTHER THAN	
U150B ECM CAN 3	168	MAIN SWITCH) DOES NOT FUNCTION	183
DTC Logic	168	Description	183
Diagnosis Procedure	168	Diagnosis Procedure	183
U150C VDC CAN 3	169	ICC SYSTEM DOES NOT CANCEL WHEN	
DTC Logic	169	CVT SELECTOR LEVER SETS ON "N"	184
Diagnosis Procedure	169	Description	184
U150D TCM CAN 3	170	Diagnosis Procedure	184
DTC Logic	170	CHIME DOES NOT SOUND	185
Diagnosis Procedure	170	Description	185
U150E BCM CAN 3	171	Diagnosis Procedure	185
DTC Logic	171	DRIVING FORCE IS HUNTING	187
Diagnosis Procedure	171	Description	187
U1502 ICC SENSOR CAN COMM CIRC	172	Diagnosis Procedure	187
DTC Logic	172	FREQUENTLY CANNOT DETECT THE VEHI-	
Diagnosis Procedure	172	CLE AHEAD / DETECTION ZONE IS SHORT..	188
U1513 METER CAN 3	173	Description	188
DTC Logic	173	Diagnosis Procedure	188

THE SYSTEM DOES NOT DETECT THE VEHICLE AHEAD AT ALL	190	Removal and Installation	197	
Description	190	ASCD		A
Diagnosis Procedure	190	PRECAUTION	199	
NORMAL OPERATING CONDITION	192	PRECAUTIONS	199	B
Description	192	Precaution for Supplemental Restraint System (SRS) "AIR BAG" and "SEAT BELT PRE-TENSIONER"	199	C
REMOVAL AND INSTALLATION	195	SYSTEM DESCRIPTION	200	
ICC SENSOR	195	AUTOMATIC SPEED CONTROL DEVICE (ASCD)	200	D
Exploded View	195	Information	200	E
Removal and Installation	195			F
ICC STEERING SWITCH	197			G
Exploded View	197			H
				I
				J
				K
				L
				M
				N
				P



PRECAUTION

PRECAUTIONS

Precaution for Supplemental Restraint System (SRS) "AIR BAG" and "SEAT BELT PRE-TENSIONER"

INFOID:000000011132034

The Supplemental Restraint System such as "AIR BAG" and "SEAT BELT PRE-TENSIONER", used along with a front seat belt, helps to reduce the risk or severity of injury to the driver and front passenger for certain types of collision. This system includes dual stage front air bag modules. The SRS system may only deploy one front air bag, depending on the severity of a collision and whether the front passenger seat is occupied. Information necessary to service the system safely is included in the SR and SB section of this Service Manual.

WARNING:

- To avoid rendering the SRS inoperative, which could increase the risk of personal injury or death in the event of a collision which would result in air bag inflation, all maintenance must be performed by an authorized NISSAN/INFINITI dealer.
- Improper maintenance, including incorrect removal and installation of the SRS, can lead to personal injury caused by unintentional activation of the system. For removal of Spiral Cable and Air Bag Module, see the SR section.
- Do not use electrical test equipment on any circuit related to the SRS unless instructed to in this Service Manual. SRS wiring harnesses can be identified by yellow and/or orange harnesses or harness connectors.

PRECAUTIONS WHEN USING POWER TOOLS (AIR OR ELECTRIC) AND HAMMERS

WARNING:

- When working near the Airbag Diagnosis Sensor Unit or other Airbag System sensors with the Ignition ON or engine running, DO NOT use air or electric power tools or strike near the sensor(s) with a hammer. Heavy vibration could activate the sensor(s) and deploy the air bag(s), possibly causing serious injury.
- When using air or electric power tools or hammers, always switch the Ignition OFF, disconnect the battery and wait at least three minutes before performing any service.

Precautions For Harness Repair

INFOID:000000011132035

ITS communication uses a twisted pair line. Be careful when repairing it.

- Solder the repaired area and wrap tape around the soldered area.

NOTE:

A fray of twisted lines must be within 110 mm (4.33 in).

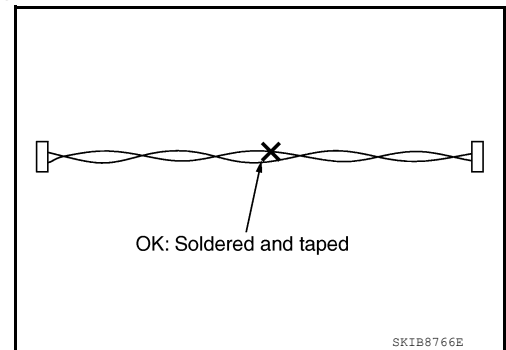

- Bypass connection is never allowed at the repaired area.

NOTE:

Bypass connection may cause ITS communication error. The spliced wire becomes separated and the characteristics of twisted line are lost.

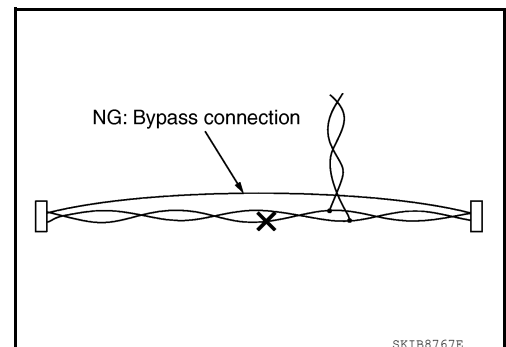

PRECAUTIONS

< PRECAUTION >

[ICC]

ICC System Service

INFOID:0000000011132036

CAUTION:

- Turn the MAIN switch OFF in conditions similar to driving, such as free rollers or a chassis dynamometer.
- Never use the ICC sensor removed from vehicle. Never disassemble or remodel.
- Erase DTC when replacing parts of ICC system, then check the operation of ICC system after adjusting radar alignment if necessary.

A
B
C
D
E
F
G
H
I
J
K
L
M
N
P

CCS

PREPARATION

< PREPARATION >

[ICC]

PREPARATION

PREPARATION

Special Service Tools

INFOID:000000011132037

The actual shape of the tools may differ from those illustrated here.

Tool number (TechMate No.) Tool name	Description
— (1-20-2721-1-IF) ICC Alignment Kit	Adjusting ICC sensor
— (1-20-2722-1-IF) Wheel Adaptor	Adjusting ICC sensor
— (J-51093) ICC Sensor Cone Alignment Tool	Adjusting ICC sensor

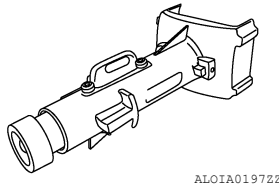
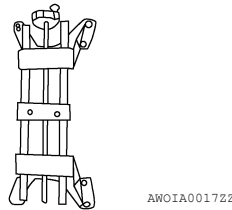
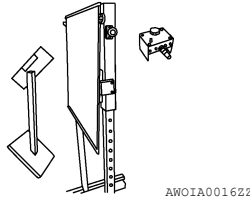

COMPONENT PARTS

< SYSTEM DESCRIPTION >

[ICC]

SYSTEM DESCRIPTION

COMPONENT PARTS

Component Parts Location

INFOID:000000011132038

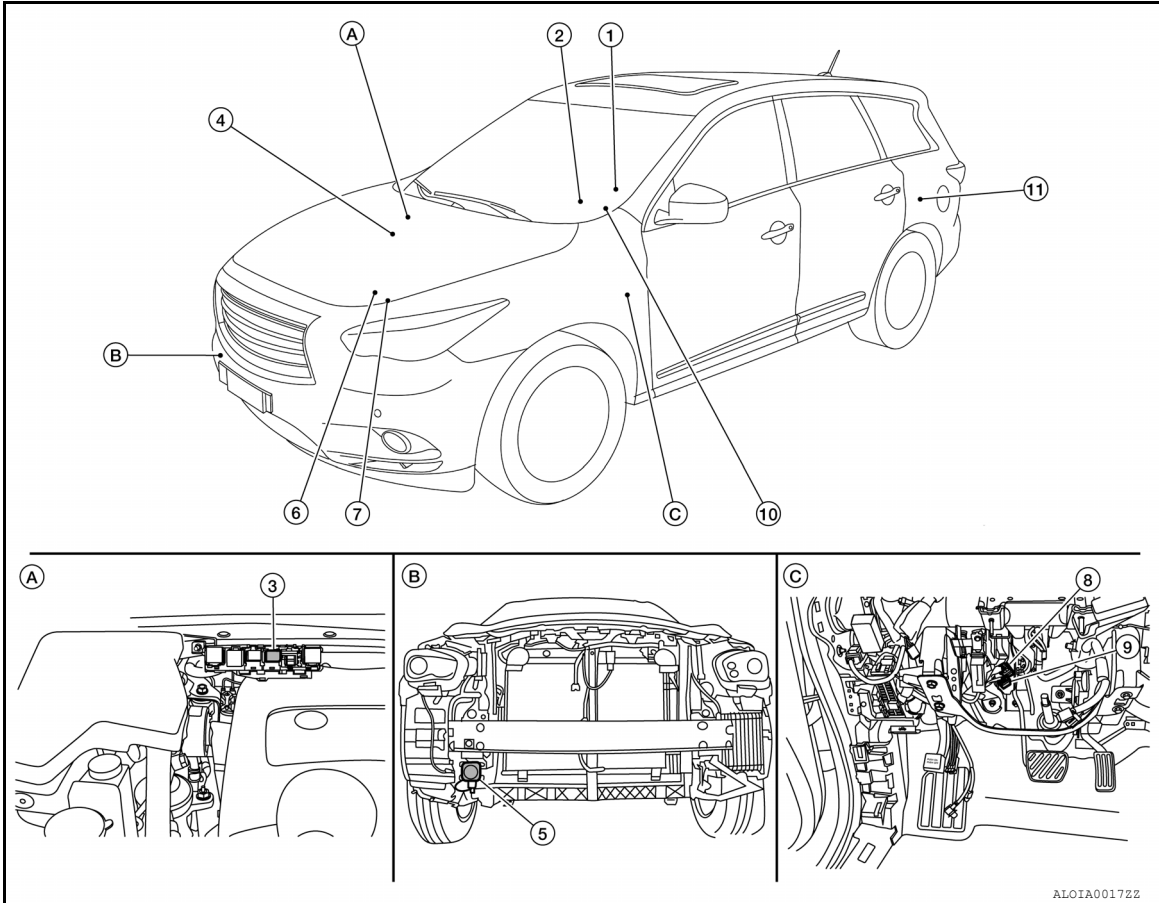

- A. Back side of engine room (RH) (view with relay cover removed) B. Radiator core support assembly (RH) (view with front bumper fascia removed) C. Upper side of brake pedal (view with instrument panel LH removed)

COMPONENT PARTS

< SYSTEM DESCRIPTION >

[ICC]

No.	Component	Function				Function
		Vehicle-to-vehicle distance control mode	Conventional (fixed speed) cruise control mode	Intelligent Brake Assist (IBA)	Brake Assist (with preview function)	
1.	ICC steering switch	×	×			<ul style="list-style-type: none"> Description: Refer to CCS-12, "ICC Steering Switch" System display and warning (Vehicle-to-vehicle distance control mode): CCS-26, "VEHICLE-TO-VEHICLE DISTANCE CONTROL MODE FUNCTION : Switch Name and Function" System display and warning (Conventional cruise control mode): CCS-29, "CONVENTIONAL (FIXED SPEED) CRUISE CONTROL MODE FUNCTION : Switch Name and Function"
2.	Combination meter (Information display, IBA OFF indicator lamp, buzzer)	×	×	×	×	<ul style="list-style-type: none"> Description: Refer to CCS-13, "Combination Meter" System display and warning (Vehicle-to-vehicle distance control mode): CCS-26, "VEHICLE-TO-VEHICLE DISTANCE CONTROL MODE FUNCTION : Menu Displayed by Pressing Each Switch" System display and warning (Conventional cruise control mode): CCS-30, "CONVENTIONAL (FIXED SPEED) CRUISE CONTROL MODE FUNCTION : Menu Displayed by Pressing Each Switch"
3.	ICC brake hold relay	×		×		Refer to CCS-12, "ICC Brake Hold Relay"
4.	ABS actuator and electric unit (control unit)	×	×	×	×	<ul style="list-style-type: none"> ABS actuator and electric unit (control unit) transmits the vehicle speed signal (wheel speed), stop lamp signal and VDC/TCS/ABS system operation condition to ADAS control unit via CAN communication ABS actuator and electric unit (control unit) controls the brake, based on a brake fluid pressure control signal received from the ADAS control unit via CAN communication Refer to BRC-8, "Component Parts Location" for detailed installation location
5.	ICC sensor	×	×	×	×	Refer to CCS-11, "ICC Sensor"
6.	TCM	×	×			TCM transmits the signal related to CVT control to ADAS control unit via CAN communication Refer to TM-14, "CVT CONTROL SYSTEM : Component Parts Location" (RE0F10E) or TM-228, "CVT CONTROL SYSTEM : Component Parts Location" (RE0F10J) for detailed installation location
7.	ECM	×	×	×	×	<ul style="list-style-type: none"> ECM transmits the accelerator pedal position signal, brake pedal position switch signal, stop lamp switch signal, ICC steering switch signal, etc. to ADAS control unit via CAN communication ECM controls the electric throttle control actuator based on the engine torque demand received from the ADAS control unit via CAN communication Refer to EC-22, "ENGINE CONTROL SYSTEM : Component Parts Location" (except for Mexico) or EC-555, "ENGINE CONTROL SYSTEM : Component Parts Location" (for Mexico) for detailed installation location
8.	Stop lamp switch	×	×	×	×	Refer to CCS-12, "Brake Pedal Position Switch/Stop Lamp Switch"
9.	Brake pedal position switch	×	×	×	×	

COMPONENT PARTS

< SYSTEM DESCRIPTION >

[ICC]

No.	Component	Function				Function
		Vehicle-to-vehicle distance control mode	Conventional (fixed speed) cruise control mode	Intelligent Brake Assist (IBA)	Brake Assist (with preview function)	
10.	Steering angle sensor	×				Measures the rotation amount, rotation speed, and rotation direction of steering wheel, and then transmits them to ADAS control unit via CAN communication
11.	ADAS control unit	×	×	×	×	Refer to CCS-11, "ADAS Control Unit" Refer to DAS-18, "Component Parts Location" for detailed installation location

A
B
C
D
E
F
G
H
I
J
K
L
M
N
P

ICC Sensor

INFOID:000000011132039

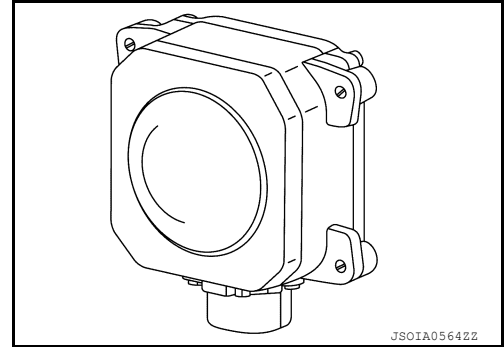

JSOIA0564ZZ

- ICC sensor is installed on the back of the front bumper and detects a vehicle ahead by using millimeter waves.
- ICC sensor detects radar reflected from a vehicle ahead by irradiating radar forward and calculates a distance from the vehicle ahead and relative speed, based on the detected signal.
- ICC sensor transmits the presence/absence of vehicle ahead and the distance from the vehicle to ADAS control unit via ITS communication.

ADAS Control Unit

INFOID:000000011132040

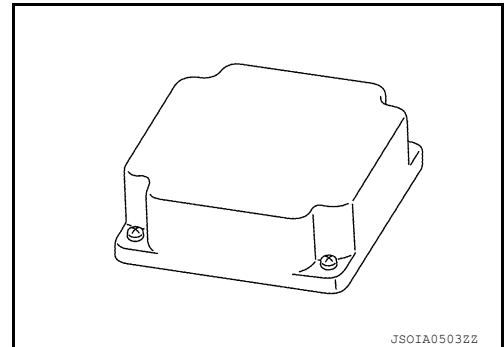

JSOIA0503ZZ

- ADAS control unit calculates a target distance between vehicles and a target speed, based on signals received from each sensor and switch to transmit an engine torque command value to ECM and a brake fluid pressure control signal to ABS actuator and electric unit (control unit) via CAN communication.
- ADAS control unit transmits buzzer output signal and meter display signal to combination meter via CAN communication.

CCS

COMPONENT PARTS

< SYSTEM DESCRIPTION >

[ICC]

Brake Pedal Position Switch/Stop Lamp Switch

INFOID:000000011132041

BRAKE PEDAL POSITION SWITCH

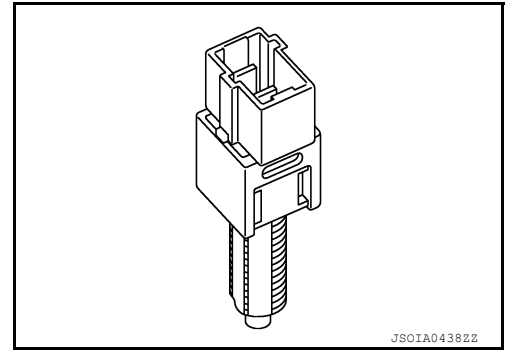

- Brake pedal position switch is installed at the upper part of the brake pedal and detects a brake operation performed by the driver.
- Brake pedal position switch is turned OFF when depressing the brake pedal.
- Brake pedal position switch signal is input to ECM. Brake pedal position switch signal is transmitted from ECM to ADAS control unit via CAN communication.

STOP LAMP SWITCH

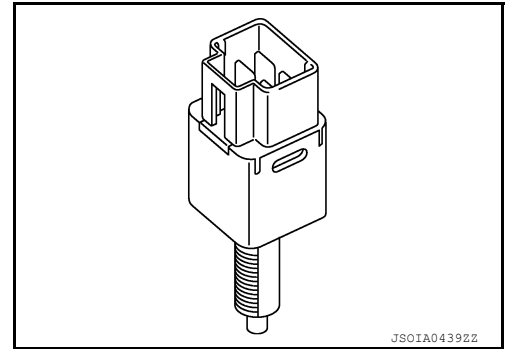

- Stop lamp switch is installed at the upper part of the brake pedal and detects a brake operation performed by the driver.
- Stop lamp switch is turned ON, when depressing the brake pedal.
- Stop lamp switch signal is input to ECM and ABS actuator and electric unit (control unit). Stop lamp switch signals are transmitted from ECM and ABS actuator and electric unit (control unit) to ADAS control unit via CAN communication.

ICC Steering Switch

INFOID:000000011132042

- ICC steering switch is installed to the steering wheel and allows the driver to operate the ICC system by using this switch.
- ICC steering switch allows the ON/OFF of the Intelligent Cruise Control and the settings of a vehicle speed and distance between vehicles.
- ICC steering switch signal is transmitted to ECM. ECM transmits the signal to the ADAS control unit via CAN communication.

ICC Brake Hold Relay

INFOID:000000011132043

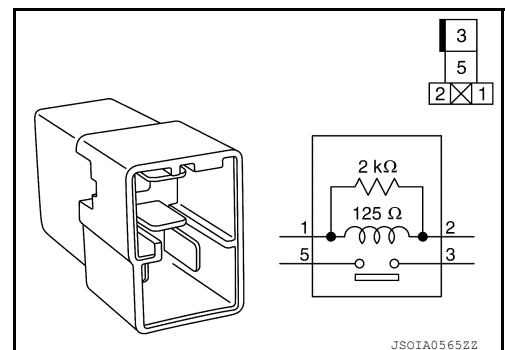

- ICC brake hold relay is installed in the engine room (right side).

COMPONENT PARTS

< SYSTEM DESCRIPTION >

[ICC]

- When the brake is activated by the ICC system, the ICC brake hold relay turns ON the stop lamp by bypassing the circuit of the stop lamp, according to a signal transmitted from the ADAS control unit.

A

Combination Meter

INFOID:0000000011132044

- Performs the following operations using the signals received from the ADAS control unit via the CAN communication.
 - Displays the ICC system operation status using the meter display signal.
 - Illuminates the ICC system warning lamp using the ICC warning lamp signal.
 - Illuminates the IBA OFF indicator lamp using the IBA OFF indicator lamp signal.
 - Operates the buzzer (ICC warning chime) using the buzzer output signal.
- Combination meter turns ON/OFF the IBA system and transmits a system selection signal to the ADAS control unit.

B

C

D

E

F

G

H

I

J

K

L

M

N

CCS

P

SYSTEM

System Description

INFOID:000000011132045

SYSTEM DIAGRAM

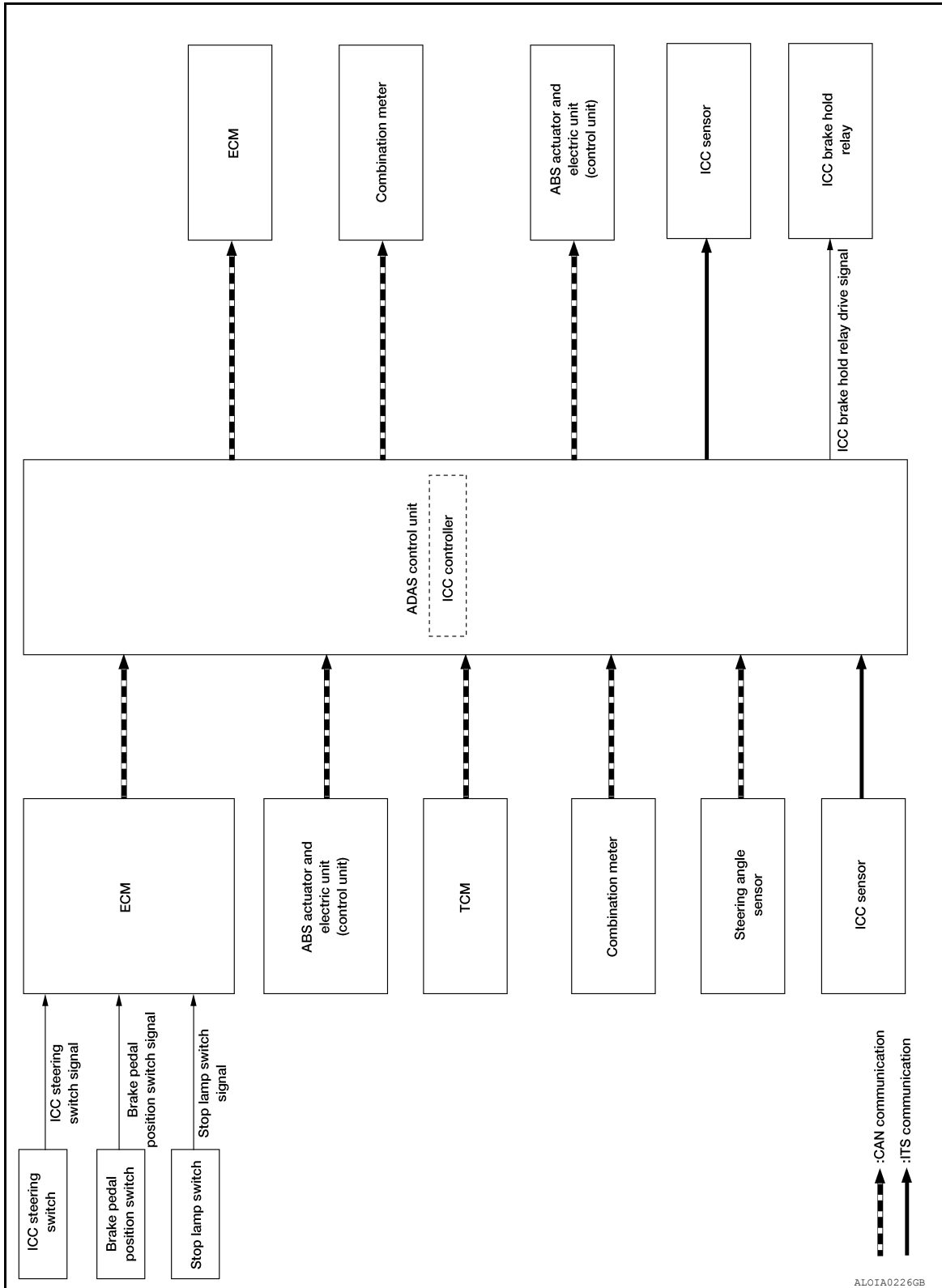

ADAS CONTROL UNIT INPUT/OUTPUT SIGNAL ITEM

Input Signal Item

SYSTEM

< SYSTEM DESCRIPTION >

[ICC]

Transmit unit	Signal name		Description	
ECM	CAN communication	Closed throttle position signal	Receives idle position state (ON/OFF)	
		Accelerator pedal position signal	Receives accelerator pedal position (angle)	
		ICC prohibition signal	Receives an operable/inoperable state of the ICC system	
		ICC steering switch signal	Main switch signal	Receives the operational state of the ICC steering switch
			SET/COAST switch signal	
			CANCEL switch signal	
			RESUME/ACCELERATE switch signal	
			DISTANCE switch signal	
		Engine speed signal	Receives engine speed	
		Stop lamp switch signal	Receives an operational state of the brake pedal	
		Brake pedal position switch signal	Receives an operational state of the brake pedal	
Snow mode switch signal	Receives an operational state of the snow mode			
TCM	CAN communication	Input speed signal	Receives the number of revolutions of input shaft	
		Current gear position signal	Receives a current gear position	
		Shift position signal	Receives a selector lever position	
		Output shaft revolution signal	Receives the number of revolutions of output shaft	
ABS actuator and electric unit (control unit)	CAN communication	ABS malfunction signal	Receives a malfunction state of ABS	
		ABS operation signal	Receives an operational state of ABS	
		ABS warning lamp signal	Receives an ON/OFF state of ABS warning lamp	
		TCS malfunction signal	Receives a malfunction state of TCS	
		TCS operation signal	Receives an operational state of TCS	
		VDC OFF switch signal	Receives an ON/OFF state of VDC	
		VDC malfunction signal	Receives a malfunction state of VDC	
		VDC operation signal	Receives an operational state of VDC	
		Vehicle speed signal (ABS)	Receives wheel speeds of four wheels	
		Stop lamp switch signal	Receives an operational state of the brake pedal	
Yaw rate signal	Receives yaw rate acting on the vehicle			
Combination meter	CAN communication	Parking brake switch signal	Receives an operational state of the parking brake	
		System selection signal	Receives a selection state of IBA system	
Steering angle sensor	CAN communication	Steering angle sensor malfunction signal	Receives a malfunction state of steering angle sensor	
		Steering angle sensor signal	Receives the number of revolutions, turning direction of the steering wheel	
		Steering angle speed signal	Receives the turning angle speed of the steering wheel	
ICC sensor	ITS communication	ICC sensor signal	Receives detection results, such as the presence or absence of a leading vehicle and distance from the vehicle	

A
B
C
D
E
F
G
H
I
J
K
L
M
N
P

CCS

Output Signal Item

SYSTEM

< SYSTEM DESCRIPTION >

[ICC]

Reception unit	Signal name		Description
ECM	CAN communication	ICC operation signal	Transmits an ICC operation signal necessary for Intelligent Cruise Control
TCM	CAN communication	ICC operation signal	Transmits an ICC operation signal necessary for Intelligent Cruise Control via ECM
ABS actuator and electric unit (control unit)	CAN communication	Brake fluid pressure control signal	Transmits a brake fluid pressure control signal to activates the brake
Combination meter	CAN communication	ICC warning lamp signal	Transmits a signal to display a state of the system on the information display
		Vehicle ahead detection indicator signal	
		Set vehicle speed indicator signal	
		Set distance indicator signal	
		SET switch indicator signal	
		MAIN switch indicator signal	
		IBA OFF indicator lamp signal	<ul style="list-style-type: none"> • Transmits a signal to turn ON the IBA OFF indicator lamp • Transmits an ON/OFF state of the intelligent brake assist
		Buzzer output signal	Transmits a buzzer output signal to turn ON the buzzer of the following systems: <ul style="list-style-type: none"> • Intelligent Cruise Control (ICC) • Intelligent Brake Assist (IBA)
ICC sensor	ITS communication	Vehicle speed signal	Transmits a vehicle speed calculated by the ADAS control unit
ICC brake hold relay	ICC brake hold relay drive signal		Activates the brake hold relay and turns ON the stop lamp

DESCRIPTION

Intelligent Cruise Control

The Intelligent Cruise Control (ICC) system maintains a selected distance from the vehicle in front of own vehicle within the speed range of 0 to 144 km/h (0 to 90 MPH) up to the set speed.

The set speed can be selected by the driver between 32 to 144 km/h (20 to 90 MPH).

The vehicle travels at a set speed when the road ahead is clear.

The ICC system can be set to one of two cruise control modes:

CAUTION:

Never set the cruise speed exceeding the posted speed limit.

Vehicle-to-vehicle Distance Control Mode

For maintaining a selected distance between own vehicle and the vehicle in front of own vehicle up to the preset speed. Refer to [CCS-20, "VEHICLE-TO-VEHICLE DISTANCE CONTROL MODE FUNCTION : System Description"](#).

Conventional (Fixed Speed) Cruise Control Mode

For cruising at a preset speed. Refer to [CCS-23, "CONVENTIONAL \(FIXED SPEED\) CRUISE CONTROL MODE FUNCTION : System Description"](#).

NOTE:

In the Conventional (Fixed Speed) Cruise Control Mode, a warning chime will not sound to warn driver if own vehicle are too close to the vehicle ahead.

WARNING:

SYSTEM

< SYSTEM DESCRIPTION >

[ICC]

Always drive carefully and attentively when using either cruise control mode. To avoid serious injury or death, do not rely on the system to prevent accidents or to control the vehicle's speed in emergency situations. Do not use cruise control except in appropriate road and traffic conditions.

A

Distance Control Assist (DCA) System

DCA share the systems and components with ICC system. Refer to [DAS-89, "Component Description"](#).

B

Forward Collision Warning (FCW) System

FCW share the systems and components with ICC system. Refer to [DAS-259, "Component Description"](#).

C

Intelligent Brake Assist (IBA) System

IBA system share the systems and components with ICC system. Refer to [BRC-145, "INTELLIGENT BRAKE ASSIST : System Description"](#).

D

Brake Assist (with preview function)

Brake Assist (with preview function) share the systems and components with ICC system. Refer to [BRC-138, "BRAKE ASSIST \(WITH PREVIEW FUNCTION\) : System Description"](#).

E

F

G

H

I

J

K

L

M

N

CCS

P

SYSTEM

< SYSTEM DESCRIPTION >

[ICC]

Circuit Diagram

INFOID:000000011132046

EXCEPT FOR MEXICO

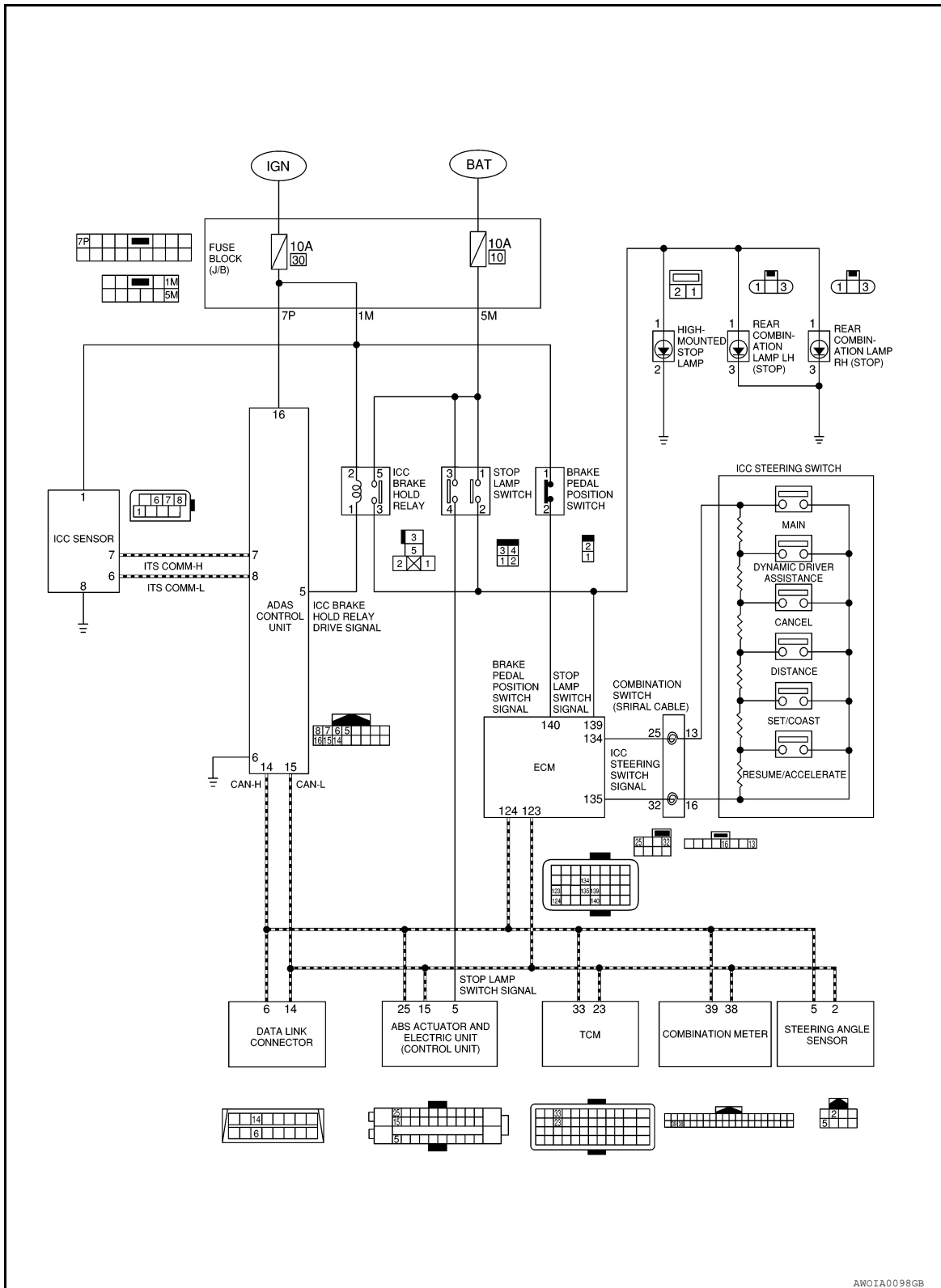

AWOIA0098GB

SYSTEM

< SYSTEM DESCRIPTION >
FOR MEXICO

[ICC]

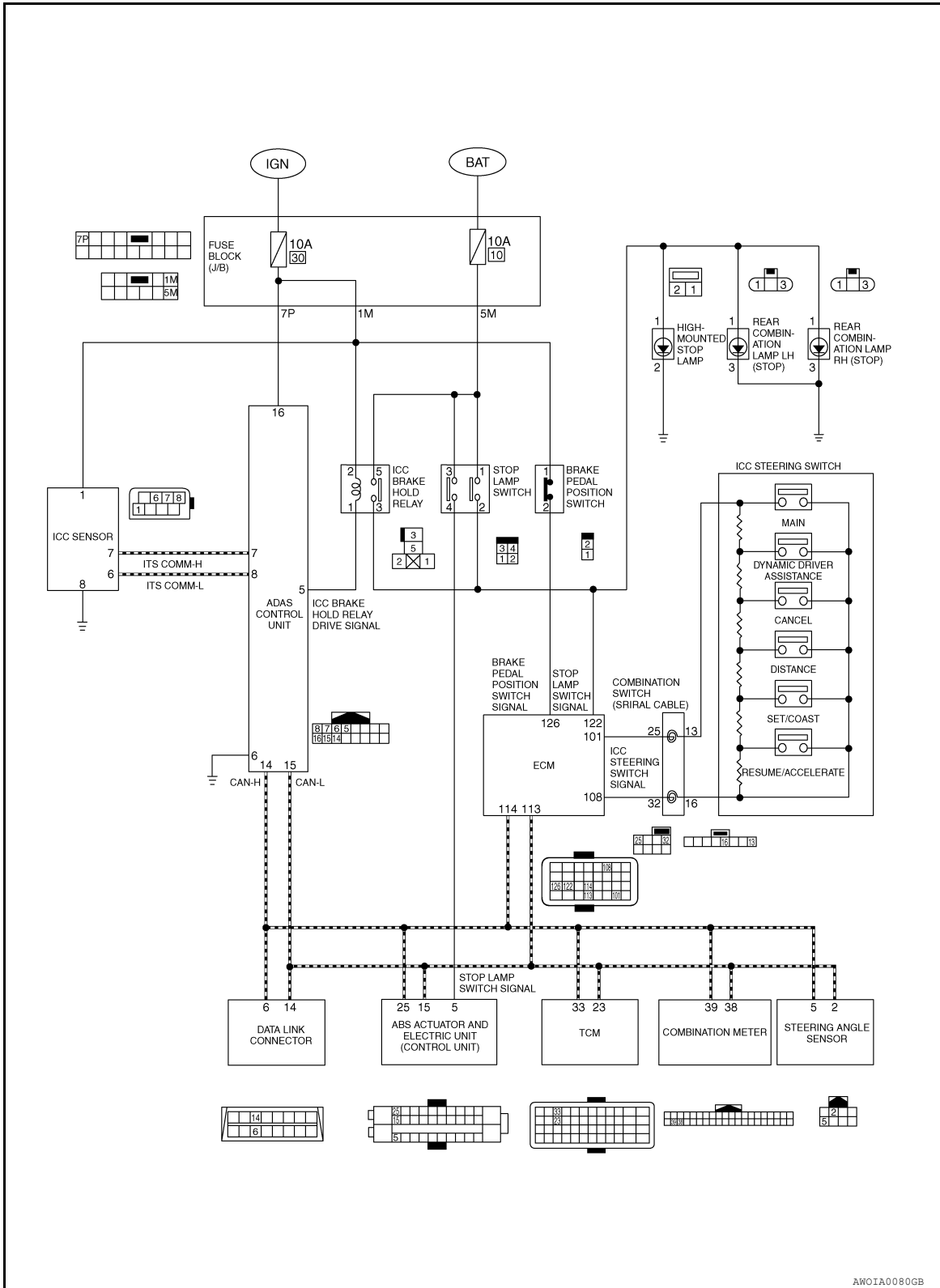

Fail-safe (ADAS Control Unit)

INFOID:000000011132047

If a malfunction occurs in each system, ADAS control unit cancels each control, sounds a beep, and turns ON the warning lamp or indicator lamp.

A
B
C
D
E
F
G
H
I
J
K
L
M
N
P

CCS

SYSTEM

< SYSTEM DESCRIPTION >

[ICC]

System	Buzzer	Warning lamp/Indicator lamp	Description
Vehicle-to-vehicle distance control mode	High-pitched tone	ICC system warning lamp	Cancel
Conventional (fixed speed) cruise control mode	High-pitched tone	ICC system warning lamp	Cancel
Intelligent Brake Assist (IBA)	High-pitched tone	IBA OFF indicator lamp	Cancel
Forward Collision Warning (FCW)	High-pitched tone	IBA OFF indicator lamp	Cancel
Distance Control Assist (DCA)	High-pitched tone	ICC system warning lamp	Cancel
Lane Departure Warning (LDW)	—	Lane departure warning lamp	Cancel
Lane Departure Prevention (LDP)	Low-pitched tone	Lane departure warning lamp	Cancel
Blind Spot Warning (BSW)	—	Blind Spot Warning/Blind Spot Intervention warning lamp	Cancel
Blind Spot Intervention (BSI)	Low-pitched tone	Blind Spot Warning/Blind Spot Intervention warning lamp	Cancel
Backup Collision Intervention (BCI)	Low-pitched tone	Backup Collision warning lamp	Cancel

Fail-safe (ICC Sensor)

INFOID:000000011132048

If a malfunction occurs in the ICC sensor, ADAS control unit cancels control, sounds a beep, and turns ON the ICC system warning lamp in the combination meter.

VEHICLE-TO-VEHICLE DISTANCE CONTROL MODE FUNCTION

VEHICLE-TO-VEHICLE DISTANCE CONTROL MODE FUNCTION : System Descrip-

SYSTEM DIAGRAM

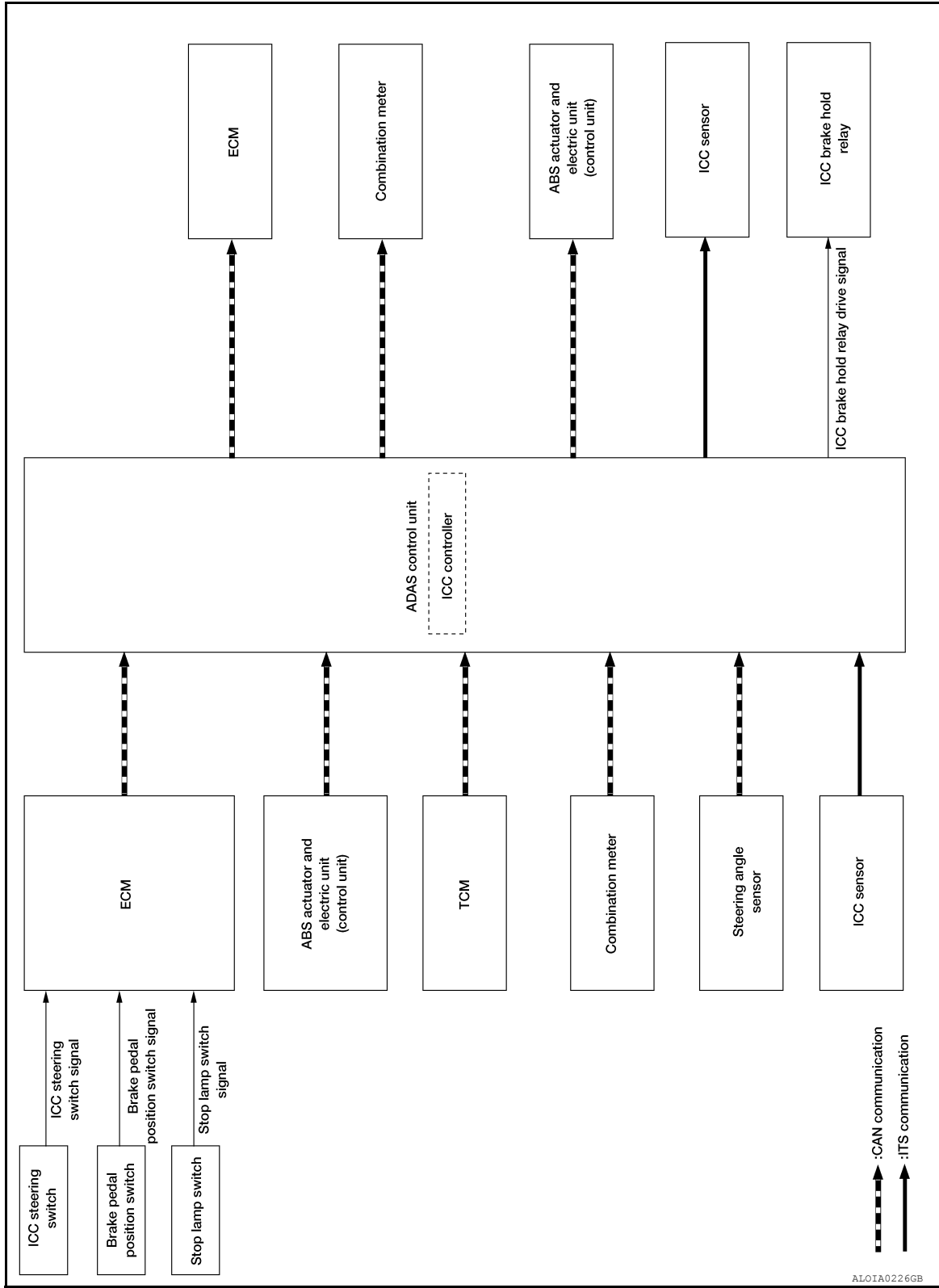

A
B
C
D
E
F
G
H
I
J
K
L
M
N
P

CCS

FUNCTION DESCRIPTION

In the vehicle-to-vehicle distance control mode, the Intelligent Cruise Control (ICC) system automatically maintains a selected distance from the vehicle traveling in front of own vehicle according to that vehicle's speed (up to the set speed), or at the set speed when the road ahead is clear.

SYSTEM

[ICC]

< SYSTEM DESCRIPTION >

With ICC system, the driver can maintain the same speed as other vehicles without the constant need to adjust the set speed as driver would with a normal cruise control system.

The following items are controlled in the vehicle-to-vehicle distance control mode

- When there are no vehicles traveling ahead, the vehicle-to-vehicle distance control mode maintains the speed set by the driver. The set speed range is between approximately 32 and 144 km/h (20 and 90 MPH).
- When there is a vehicle traveling ahead, the vehicle-to-vehicle distance control mode adjusts the speed to maintain the distance, selected by driver, from a vehicle ahead. The adjusting speed range is up to the set speed.
- When the vehicle traveling ahead has moved out from its lane of travel, the vehicle-to-vehicle distance control mode accelerates and maintains vehicle speed up to the set speed.

CAUTION:

If the vehicle ahead comes to stop, the vehicle decelerates to a standstill within the limitations of the system. The system will cancel once it judges that the vehicle has come to a standstill and sound a warning chime.

To prevent the vehicle from moving, the driver must depress the brake pedal.

NOTE:

When the accelerator pedal is depressed, the brake operation and the warning are not performed by the ICC system.

OPERATION DESCRIPTION

Quickly push (less than 1.5 seconds) and release the MAIN switch ON.

The MAIN switch indicator, set distance indicator, own vehicle indicator, and set vehicle speed indicator come on and ICC system is set to a standby state.

ADAS control unit performs the control as per the following:

Constant speed	Comparing the set vehicle speed with the current vehicle speed, transmit the command to ECM via CAN communication to reach the set vehicle speed, and controls the electric throttle control actuator
Deceleration	When a vehicle ahead (slower than driver set vehicle speed) appears or when a vehicle ahead slows down, the system controls the electric throttle control actuator into the close direction and decelerates the vehicle. If greater deceleration is necessary, the system transmits the brake fluid pressure control signal to the ABS actuator and electric unit (control unit) via CAN communication and operates the brake
Following	The system controls the electric throttle control actuator and the brake fluid pressure to keep the proper distance between the vehicles according to the vehicle speed change of the vehicle ahead
Acceleration	When a vehicle ahead is not detected because of it changes lanes or own vehicle changes lanes during the following driving, the system controls the electric throttle control actuator in the open direction and accelerates the vehicle to the set vehicle speed slowly

Set Condition

Under a standby state, pushing down the SET/COAST switch will start system control.

- When vehicle speed is between approximately 32 km/h and 144 km/h (20 MPH and 90 MPH).
- When vehicle speed is below approximately 32 km/h (20 MPH) if the vehicle ahead is detected. The set vehicle speed becomes 32 km/h (20 MPH).

If the system is canceled by conditions 1-6 below, the system will resume control at the last set cruising speed by pushing up the RESUME/ACCELERATE switch.

NOTE:

- When the SET/COAST switch is pushed under the following conditions, the system cannot be set and the set vehicle speed indicator will blink for approximately 2 seconds.
 - When traveling below 32 km/h (20 MPH) and the vehicle ahead is not detected.
 - When the selector lever is not in the "D" position or manual mode.
 - When the parking brakes are applied.
 - When the brakes are operated by the driver.
- When the SET/COAST switch is pushed under the following conditions, the system cannot be set and a warning chime will sound and displays that causes in combination meter (information display).
 - When the drive mode select switch is in SNOW position. (To use the ICC system, turn OFF the snow mode, push the ICC MAIN switch to turn OFF the ICC system and reset the ICC system by pushing the ICC MAIN switch again.)
 - When the VDC is OFF. (To use the ICC system, turn ON the VDC system, push the MAIN switch to turn OFF the ICC system and reset the ICC system by pushing the MAIN switch again.)
 - When ABS or VDC (including the TCS) operates.
 - When the wheel is slipping. (To use the ICC system, make sure the wheels are no longer spinning, push the MAIN switch to turn OFF the ICC system and reset the ICC system by pushing the MAIN switch again.)

Cancel Conditions

1. When CANCEL switch is pressed.
2. When brake pedal is depressed.
3. When the vehicle ahead is not detected below the speed of 24 km/h (15 MPH).
4. When the selector lever is not in the "D" position or manual mode.
5. When the parking brakes are applied.
6. When the system judges the vehicle is at standstill.
7. When the drive mode select switch is in SNOW position.
8. When ABS or VDC (including the TCS) operates.
9. When the MAIN switch is turned OFF.
10. When a wheel slips.
11. When the VDC is turned OFF.
12. When the system malfunction occurs.

A
B
C
D

CONVENTIONAL (FIXED SPEED) CRUISE CONTROL MODE FUNCTION

CONVENTIONAL (FIXED SPEED) CRUISE CONTROL MODE FUNCTION : System

E
F
G
H
I
J
K
L
M
N

CCS

P

Description

INFOID:000000011132050

SYSTEM DIAGRAM

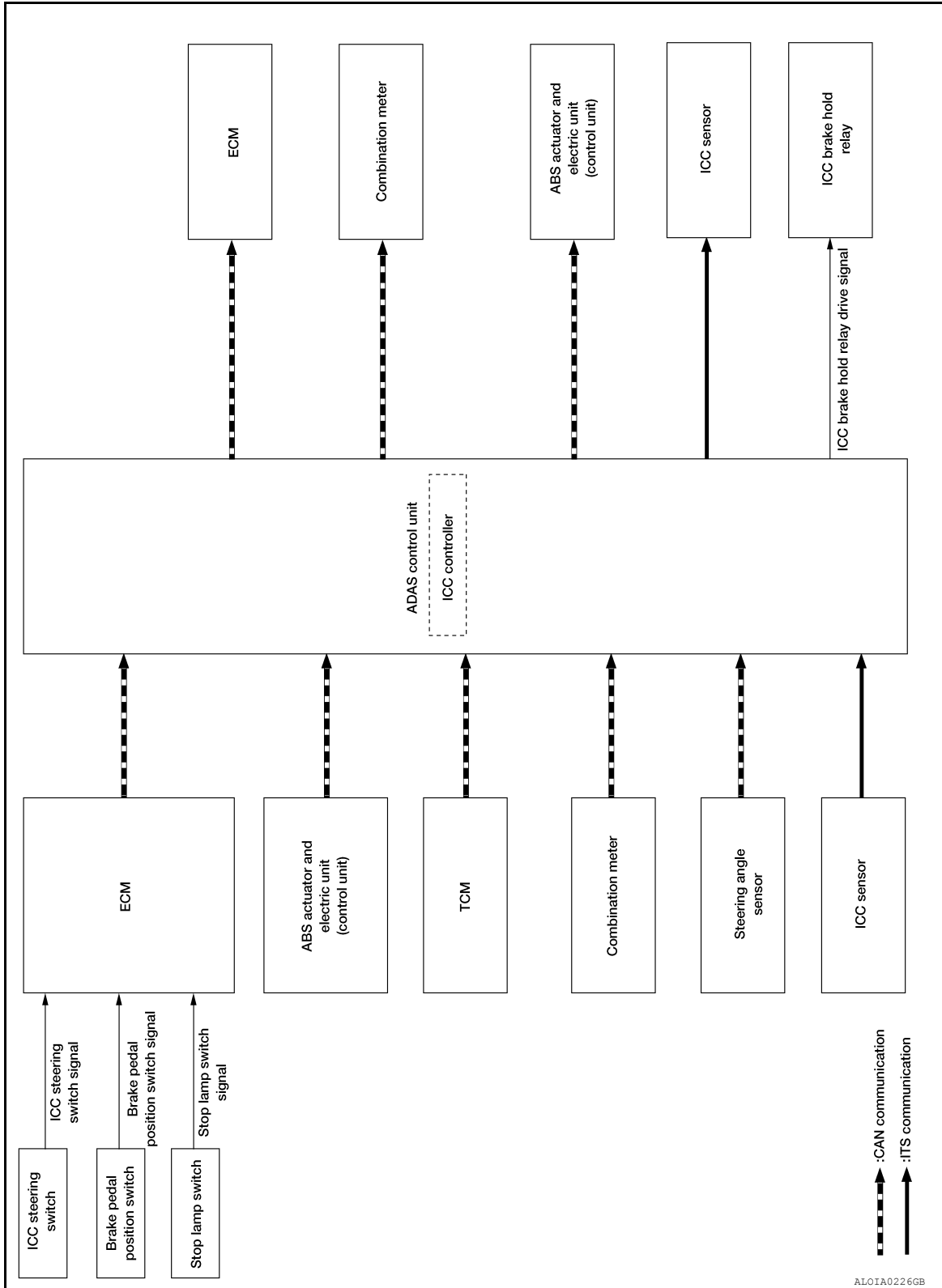

FUNCTION DESCRIPTION

This mode allows driving at a speed between 40 to 144 km/h (25 to 90 MPH) without keeping foot on the accelerator pedal.

NOTE:

SYSTEM

[ICC]

< SYSTEM DESCRIPTION >

In the conventional (fixed speed) cruise control mode, a warning chime does not sound to warn driver if own vehicle are too close to the vehicle ahead, as neither the presence of the vehicle ahead nor the vehicle-to-vehicle distance is detected.

OPERATION DESCRIPTION

To turn ON the conventional (fixed speed) cruise control mode, push and hold the MAIN switch for longer than approximately 1.5 seconds when ICC system is OFF.

When pushing the MAIN switch ON, the ICC system display and the MAIN switch indicator are displayed on the information display.

After hold the MAIN switch ON for longer than approximately 1.5 seconds, the ICC system display goes out. The MAIN switch indicator stays lit and brings the system to standby state.

NOTE:

- To turn on the vehicle-to-vehicle distance control mode again, turn OFF the system and quickly push (less than 1.5 seconds) the MAIN switch.
- When the DCA system is ON, the conventional (fixed speed) cruise control mode cannot be turned on even though the MAIN switch is pushed and held.
- To turn ON the conventional (fixed speed) cruise control mode, turn OFF the DCA system. Refer to [DAS-89](#), "[Component Description](#)".

ADAS control unit performs the control as per the following:

Constant speed	Comparing the set vehicle speed with the current vehicle speed, transmits the command to ECM via CAN communication to reach the set vehicle speed, and controls the electronic throttle control actuator.
----------------	---

Set Condition

When the system is under a standby state and the vehicle speed is between approximately 40 km/h (25 MPH) and 144 km/h (90 MPH), pushing the SET/COAST switch will start system control.

If the system is canceled by conditions 1-5 below, the system will resume control at the last set cruising speed by pushing the RESUME/ACCELERATE switch.

Cancel conditions

1. When CANCEL switch is pressed.
2. When brake pedal depressed.
3. When the vehicle slows down more than 13 km/h (8 MPH) below the set speed.
4. When the selector lever is not in the "D" position or manual mode.
5. When the parking brakes are applied.
6. When the MAIN switch is turned OFF.
7. When VDC (including the TCS) operates.
8. When a wheel slips.
9. When the system malfunction occurs.

A
B
C
D
E
F
G
H
I
J
K
L
M
N
P

CCS

OPERATION

VEHICLE-TO-VEHICLE DISTANCE CONTROL MODE FUNCTION

VEHICLE-TO-VEHICLE DISTANCE CONTROL MODE FUNCTION : Switch Name and Function

INFOID:000000011132051

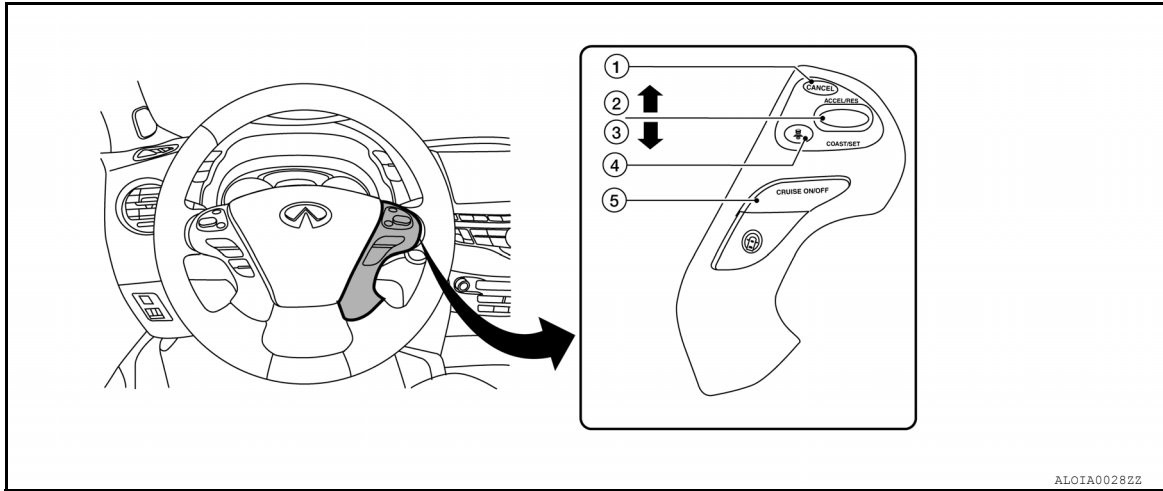

ALOIA00282Z

No.	Switch name	Description
1	CANCEL switch	Deactivates the system without erasing the set speed
2	RESUME/ACCELERATE switch	Resumes set speed or increases speed incrementally • Push and hold the switch to increase the set speed by 8 km/h (5 MPH) • Push then quickly release the switch to increase the set speed by 1.6 km/h (1 MPH)
3	SET/COAST switch	Sets desired cruise speed or reduces speed incrementally • Push and hold the switch to decrease the set speed by 8 km/h (5 MPH) • Push then quickly release the switch to decrease the set speed by 1.6 km/h (1 MPH) NOTE: The minimum set speed is 32 km/h (20 MPH)
4	DISTANCE switch	Changes the following distance from: Long, Middle, Short
5	MAIN switch	Master switch to activate the system (Press for less than 1.5 seconds)

VEHICLE-TO-VEHICLE DISTANCE CONTROL MODE FUNCTION : Menu Displayed by Pressing Each Switch

INFOID:000000011132052

ICC SYSTEM DISPLAY (ON THE INFORMATION DISPLAY)

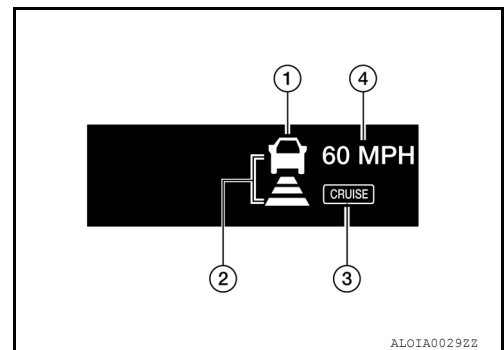

ALOIA00292Z

No.	Display item	Description
1	Vehicle ahead detection indicator	Indicates whether it detects a vehicle ahead
2	Set distance indicator	Indicates the selected distance between vehicles set with the DISTANCE switch

OPERATION





< SYSTEM DESCRIPTION >

[ICC]

No.	Display item	Description
3	Main switch indicator (white)	White: Indicates the main switch is ON (ICC system ON)
	ICC system warning lamp (orange)	Orange: Indicates that a malfunction occurred in the ICC system
4	Set vehicle speed indicator	<ul style="list-style-type: none"> Indicates the set vehicle speed Indicates 32 km/h (20 MPH) when setting less than 32 km/h (20 MPH)

SYSTEM CONTROL CONDITION DISPLAY





Push and hold the ICC MAIN switch for longer than approximately 1.5 seconds. This mode will be in a standby state for setting.

Condition		Display on ICC system display
Standby mode		 <p style="text-align: right; font-size: small;">ALOIA00302Z</p>
Control mode	Without a vehicle ahead	Set vehicle distance (Long)  <p style="text-align: right; font-size: small;">ALOIA00312Z</p>
		Set vehicle distance (Middle)  <p style="text-align: right; font-size: small;">ALOIA00322Z</p>
		Set vehicle distance (Short)  <p style="text-align: right; font-size: small;">ALOIA00332Z</p>
		When the vehicle speed exceeds the set speed  <p style="text-align: right; font-size: small;">ALOIA00342Z</p>

OPERATION

< SYSTEM DESCRIPTION >

[ICC]

		Condition	Display on ICC system display
Control mode	With a vehicle ahead	Set vehicle distance (Long)	 <small>ALOIA0035ZZ</small>
		Set vehicle distance (Middle)	 <small>ALOIA0036ZZ</small>
		Set vehicle distance (Short)	 <small>ALOIA0037ZZ</small>
		When the vehicle speed exceeds the set speed	 <small>ALOIA0038ZZ</small>

NOTE:

The display of the DCA system is given priority when the DCA system is ON in a standby mode. (The set vehicle speed indicator and set distance indicator are not displayed).

APPROACH WARNING DISPLAY

If own vehicle comes closer to a vehicle ahead due to rapid deceleration of that vehicle or if another vehicle cuts in, the system warns the driver with the chime and ICC system display. Decelerate by depressing the brake pedal to maintain a safe vehicle distance if:

- The chime sounds.
- The vehicle ahead detection indicator blinks in orange.

The warning chime may not sound in some cases when there is a short distance between vehicles. Some examples are:

- When the vehicles are traveling at the same speed and the distance between vehicles is not changing.
- When the vehicle ahead is traveling faster and the distance between vehicles is increasing.
- When a vehicle cuts in at near own vehicle.

The warning chime will not sound when own vehicle approaches vehicles that are parked or moving slowly. The warning chime will not sound when the accelerator pedal is depressed, overriding the system.

The approach warning chime may sound and the system display may blink when the ICC sensor detects some reflectors which are fitted on vehicles in other lanes or on the side of the road.

This may cause the ICC system to decelerate or accelerate the vehicle.

The ICC sensor may detect these objects when the vehicle is driven on winding roads, hilly roads or when entering or exiting a curve.

The ICC sensor may also detect reflectors on narrow roads or in road construction zones.

In these cases driver will have to manually control the proper distance ahead of own vehicle.

Also, the sensor sensitivity can be affected by vehicle operation (steering maneuver or driving position in the lane) or traffic or vehicle condition (for example, if a vehicle is being driven with some damage).



OPERATION

< SYSTEM DESCRIPTION >

[ICC]

Condition	Display on ICC system display
<p>When own vehicle comes closer to the vehicle ahead and it is judged that the distance between the vehicles is not sufficient</p>	 <p style="text-align: right; font-size: small;">ALOIA00392Z</p>

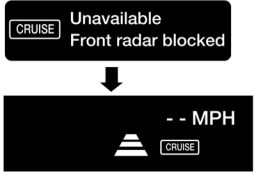
WARNING LAMP AND AUTOMATIC CANCELLATION DISPLAY

Condition	Description	Display on ICC system display
<p>Automatic cancellation display</p> <ul style="list-style-type: none"> When brake pedal is depressed When CANCEL switch is pressed When a vehicle ahead is not detected below the speed of 24 km/h (15 MPH) When the system judges the vehicle is at standstill When the selector lever is not in "D" position or manual mode When the parking brake are applied 	<p>A chime sounds and the control is automatically canceled.</p> <p>NOTE:</p> <ul style="list-style-type: none"> The system will be in a standby, after the control is automatically canceled. A chime sounds when the control is automatically canceled, except when brake pedal is depressed or when CANCEL switch is pressed. 	 <p style="text-align: right; font-size: small;">ALOIA0030ZZ</p>
<p>Warning display</p> <ul style="list-style-type: none"> When the VDC is turned OFF When the VDC or ABS (including the TCS) operates When a wheel slips When the driver mode selector (DMS) switch is in SNOW mode 	<p>A chime sounds and the control is automatically canceled.</p> <p>NOTE:</p> <p>When the conditions listed are no longer present, turn the system OFF using the MAIN switch. Turn the ICC system back on to use the system.</p>	<p>Example: When the front bumper near the ICC sensor is blocked or dirty, making it impossible to detect a vehicle ahead.</p> <div style="text-align: center;">  <p style="text-align: right; font-size: small;">ALOIA0040ZZ</p> </div>
<p>When the ICC system is malfunctioning</p>	<p>A chime sounds and the control is automatically canceled.</p> <p>NOTE:</p> <p>Turn the engine OFF and restart engine. If there is no malfunction, it is possible to set the system.</p>	 <p style="text-align: right; font-size: small;">ALOIA0053ZZ</p>

NOTE:
When the ICC system is automatically canceled, the cancellation condition can be displayed on "WORK SUPPORT" of CONSULT (ICC/ADAS).

CONVENTIONAL (FIXED SPEED) CRUISE CONTROL MODE FUNCTION

CONVENTIONAL (FIXED SPEED) CRUISE CONTROL MODE FUNCTION : Switch

A
B
C
D
E
F
G
H
I
J
K
L
M
N
P

CCS

OPERATION

< SYSTEM DESCRIPTION >

[ICC]

Name and Function

INFOID:000000011132053

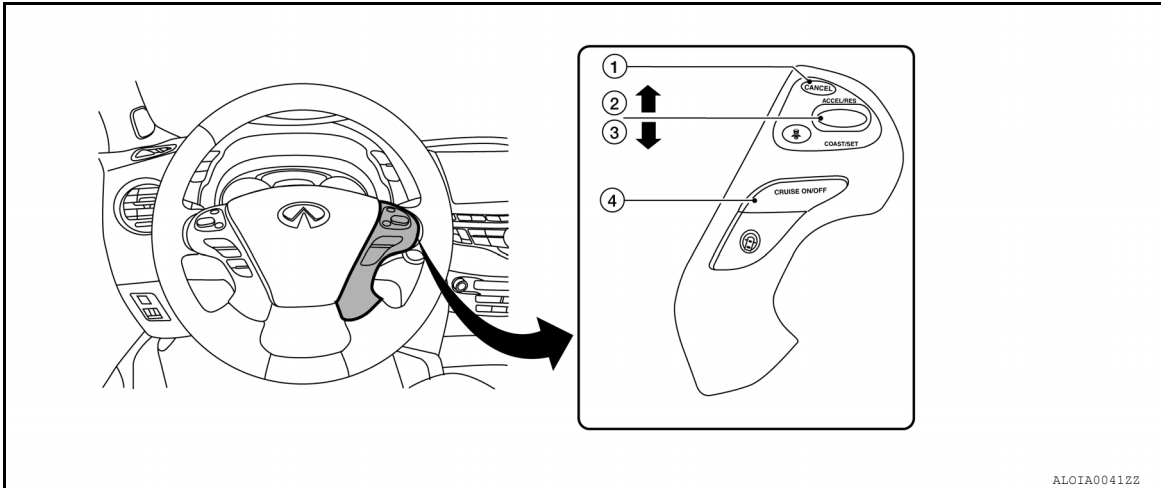

ALOIA00412Z

No.	Description	Function
1	CANCEL switch	Deactivates system without erasing set speed
2	RESUME/ACCELERATE switch	Resumes set speed or increases speed incrementally
3	SET/COAST switch	Sets desired cruise speed or reduces speed incrementally
4	MAIN switch	Master switch to activate the system (Press for more than 1.5 seconds)

CONVENTIONAL (FIXED SPEED) CRUISE CONTROL MODE FUNCTION : Menu Displayed by Pressing Each Switch

INFOID:000000011132054

ICC SYSTEM DISPLAY (ON THE INFORMATION DISPLAY)

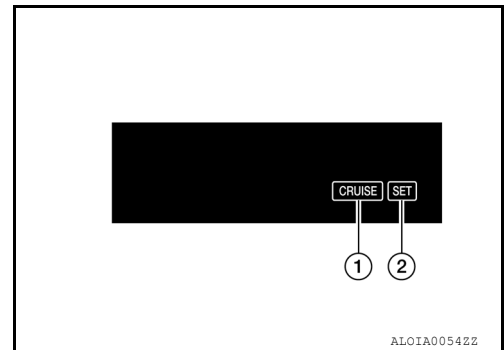

ALOIA00542Z

No.	Display item	Description
1	MAIN switch indicator (white)	White: Indicates that the main switch is ON (ICC system ON)
	ICC system warning lamp (orange)	Orange: Indicates that a malfunction occurred in the ICC system
2	SET switch indicator	Indicates that the set conventional (fixed speed) cruise control mode is controlled



SYSTEM CONTROL CONDITION DISPLAY

Push and hold the ICC MAIN switch for longer than approximately 1.5 seconds. This mode will be in a standby state for setting.

OPERATION



< SYSTEM DESCRIPTION >

[ICC]

Condition	Display on ICC system display
Standby mode	 <p style="text-align: center; font-size: small; margin-top: 5px;">ALOIA0053ZZ</p>
Control mode	 <p style="text-align: center; font-size: small; margin-top: 5px;">ALOIA0055ZZ</p>

A
B
C
D
E
F

WARNING AND AUTOMATIC CANCELLATION DISPLAY

Condition	Description	Display on ICC system display
Warning display	When the ICC system is malfunctioning A chime sounds and the control is automatically canceled. NOTE: Turn the engine OFF and restart engine. If there is no malfunction, it is possible to set the system	 <p style="text-align: center; font-size: small; margin-top: 5px;">ALOIA0053ZZ</p>
System cancel display	<ul style="list-style-type: none"> • When brake pedal is depressed • When pressing CANCEL switch • When the vehicle slows down more than (13 km/h) 8 MPH below the set speed • When the selector lever is not in the "D" position or manual mode • When the parking brakes are applied • When VDC (including the TCS) operates • When a wheel slips A chime sounds and the control is automatically canceled NOTE: <ul style="list-style-type: none"> • The system will be in a standby, after the control is automatically canceled • A chime sounds when the control is automatically canceled, except when brake pedal is depressed or when CANCEL switch is pressed 	 <p style="text-align: center; font-size: small; margin-top: 5px;">ALOIA0053ZZ</p>

G
H
I
J
K
L

NOTE:
When the ICC system is automatically canceled, the cancellation condition can be displayed on "WORK SUPPORT" of CONSULT (ICC/ADAS).

M
N

CCS

P

HANDLING PRECAUTION

Precautions for Vehicle-to-Vehicle Distance Control Mode

INFOID:000000011132055

- ICC system is only an aid to assist the driver and is not a collision warning or avoidance system. It is the driver's responsibility to stay alert, drive safely and be in control of the vehicle at all times.
- The system is primarily intended for use on straight, dry, open roads with light traffic. It is not advisable to use the system in city traffic or congested areas.
- This system will not adapt automatically to road conditions. This system should be used in evenly flowing traffic. Never use the system on roads with sharp curves, or on icy roads, in heavy rain or in fog.
- The ICC sensor will not detect the following objects:
 - Stationary and slow moving vehicles.
 - Pedestrians or objects in the roadway.
 - Oncoming vehicles in the same lane.
 - Motorcycles traveling offset in the travel lane.
- As there is a performance limit to the distance control function, never rely solely on the ICC system. This system does not correct careless, inattentive or absent-minded driving, or overcome poor visibility in rain, fog, or other bad weather. Decelerate the vehicle speed by depressing the brake pedal, depending on the distance to the vehicle ahead and the surrounding circumstances in order to maintain a safe distance between vehicles.
- If the vehicle ahead comes to a stop, the vehicle decelerates to a standstill within the limitations of the system. The system will cancel once it judges that the vehicle has come to a standstill and sound a warning chime. To prevent the vehicle from moving, the driver must depress the brake pedal.
- The system may not detect the vehicle in front of the driver in certain road or weather conditions. To avoid accidents, never use the ICC system under the following conditions:
 - On roads where the traffic is heavy or there are sharp curves.
 - On slippery road surfaces such as on ice or snow, etc.
 - During bad weather (rain, fog, snow, etc.)
 - When rain, snow or dirt adhere to the ICC sensor.
 - On steep downhill roads (the vehicle may go beyond the set vehicle speed and frequent braking may result in overheating the brakes).
 - On repeated uphill and downhill roads.
 - When traffic conditions make it difficult to keep a proper distance between vehicles because of frequent acceleration or deceleration.
 - Never use the ICC system if own vehicle is towing a trailer. The system may not detect a vehicle ahead.
- In some road or traffic conditions, a vehicle or object can unexpectedly come into the sensor detection zone and cause automatic braking. The driver may need to control the distance from other vehicles using the accelerator pedal. Always stay alert and avoid using the ICC system when it is not recommended in this section.
- The vehicle-to-vehicle distance control mode uses a sensor located behind the front bumper of the vehicle to detect vehicles traveling ahead. The sensor generally detects the signals returned from the vehicle ahead. Therefore, if the sensor cannot detect the reflection from the vehicle ahead, the ICC system may not maintain the selected distance.
- The following are some conditions in which the sensor cannot detect the signals:
 - When the snow or road spray from traveling vehicles reduces the sensor's visibility.
 - When excessively heavy baggage is loaded in the rear seat or the luggage room of own vehicle.
- The ICC system is designed to automatically check the sensor's operation within the limitation of the system. When the front bumper area of the ICC sensor is covered with dirt or is obstructed, the system will automatically cancel. If the front bumper area of the ICC sensor is covered with ice, a transparent or translucent vinyl bag, etc., the ICC system may not detect them. In these instances, the vehicle-to-vehicle distance control mode may not cancel and may not be able to maintain the selected following distance from the vehicle ahead. Be sure to check and clean the front bumper area of the ICC sensor regularly.
- The ICC system does not control vehicle speed or warn the driver when own vehicle approaches stationary and slow moving vehicles. The driver must pay attention to vehicle operation to maintain proper distance from vehicles ahead when approaching toll gates or traffic congestion.

HANDLING PRECAUTION

[ICC]

< SYSTEM DESCRIPTION >

- The detection zone of the ICC sensor is limited. A vehicle ahead must be in the detection zone for the vehicle-to-vehicle distance detection mode to maintain the selected distance from the vehicle ahead. A vehicle ahead may move outside of the detection zone due to its position within the same lane of travel. Motorcycles may not be detected in the same lane ahead if they are traveling offset from the center line of the lane. A vehicle that is entering the lane ahead may not be detected until the vehicle has completely moved into the lane. If this occurs, the ICC system may warn the driver by blinking the system indicator and sounding the chime. The driver may have to manually control the proper distance away from vehicle traveling ahead.

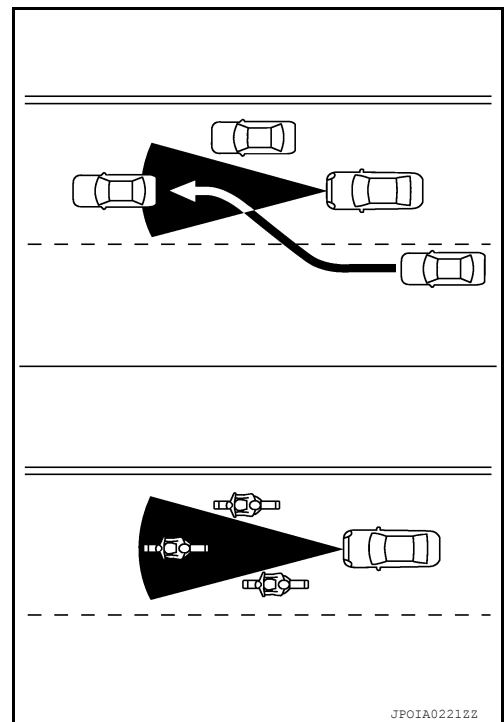

- When driving on some roads, such as winding, hilly, curved, narrow roads, or roads which are under construction, the ICC sensor may detect vehicles in a different lane, or may temporarily not detect a vehicle traveling ahead. This may cause the ICC system to decelerate or accelerate the vehicle. The detection of vehicles may also be affected by vehicle operation (steering maneuver or traveling position in the lane, etc.) or vehicle condition. If this occurs, the ICC system may warn the driver by blinking the system indicator and sounding the chime unexpectedly. The driver will have to manually control the proper distance away from the vehicle traveling ahead.

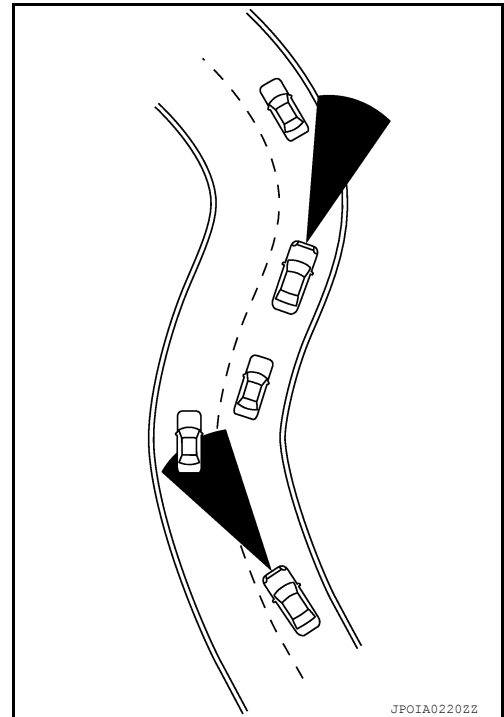

- When driving on the freeway at a set speed and approaching a slower traveling vehicle ahead, the ICC will adjust the speed to maintain the distance, selected by the driver, from the vehicle ahead. If the vehicle ahead changes lanes or exits the freeway, the ICC system will accelerate and maintain the speed up to the set speed. Pay attention to the driving operation to maintain control of the vehicle as it accelerates to the set speed. The vehicle may not maintain the set speed on winding or hilly roads. If this occurs, the driver will have to manually control the vehicle speed.

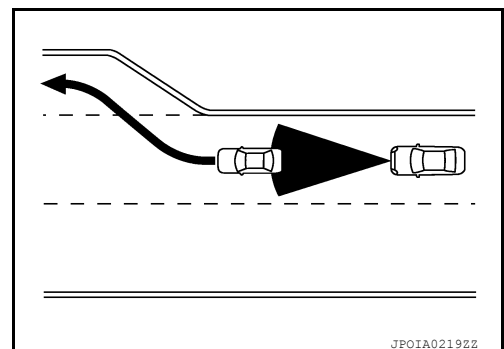

A
B
C
D
E
F
G
H
I
J
K
L
M
N

CCS

P

HANDLING PRECAUTION

< SYSTEM DESCRIPTION >

[ICC]

- Normally when controlling the distance to a vehicle ahead, this system automatically accelerates or decelerates own vehicle according to the speed of the vehicle ahead. Depress the accelerator to properly accelerate own vehicle when acceleration is required for a lane change. Depress the brake pedal when deceleration is required to maintain a safe distance to the vehicle ahead due to its sudden braking or if a vehicle cuts in. Always stay alert when using the ICC system.
- The sensor sensitivity can be affected by vehicle operation (steering maneuver or driving position in the lane) or traffic or vehicle condition (for example, if a vehicle is being driven with some damage).

Precautions for Conventional (Fixed Speed) Cruise Control Mode

INFOID:000000011132056

- In the conventional (fixed speed) cruise control mode, a warning chime does not sound to warn the driver if own vehicle is too close to the vehicle ahead, as neither the presence of the vehicle ahead nor the vehicle-to-vehicle distance is detected.
- Pay special attention to the distance between own vehicle and the vehicle ahead or a collision could occur.
- Always confirm the setting in the ICC system display.
- Never use the conventional (fixed speed) cruise control mode when driving under the following conditions:
 - When it is not possible to keep the vehicle at a set speed.
 - In heavy traffic or in traffic that varies in speed.
 - On winding or hilly roads.
 - On slippery roads (rain, snow, ice, etc.).
 - In very windy areas.
- Doing so could cause a loss of vehicle control and result in an accident.
- To avoid accidentally engaging cruise control, make sure to the MAIN switch OFF when not using ICC system.

DIAGNOSIS SYSTEM (ADAS CONTROL UNIT)

< SYSTEM DESCRIPTION >

[ICC]

DIAGNOSIS SYSTEM (ADAS CONTROL UNIT)

On Board Diagnosis Function

INFOID:000000011558201

DESCRIPTION

The DTC is displayed on the information display by operating the ICC steering switch.

On Board Self-diagnosis System Diagram

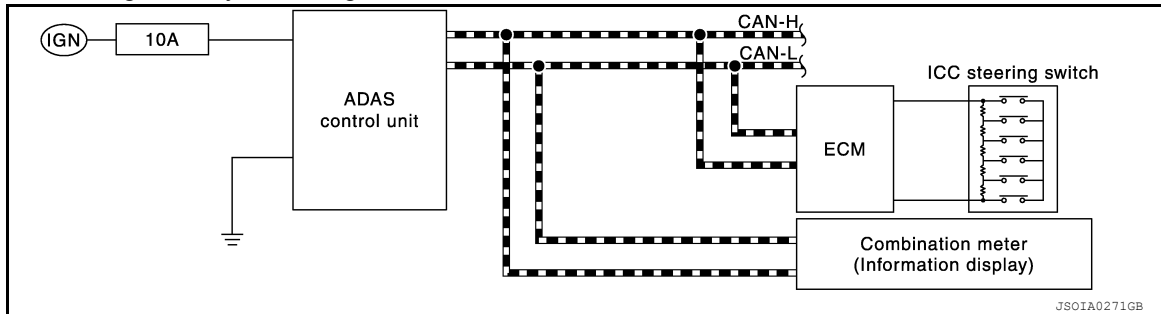

METHOD OF STARTING

CAUTION:

Start condition of on board self-diagnosis

- ICC system OFF
- DCA system OFF
- Vehicle speed 0 km/h (0 MPH)

1. Turn the ignition switch OFF.
2. Start the engine.
3. Wait for 5 seconds after starting the engine. Push up the RESUME/ACCELERATE switch 5 times and push down the SET/COAST switch 5 times within 10 seconds.

NOTE:

If the above operation cannot be performed within 10 seconds after waiting for 5 seconds after starting the engine, repeat the procedure from step 1.

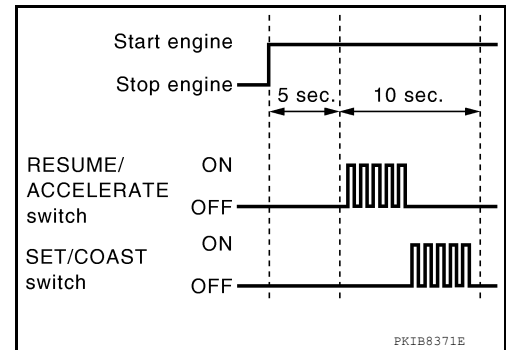

4. The DTC is displayed on the set vehicle speed indicator (1) on the ICC system display on the information display when the on board self-diagnosis starts. Refer to [DAS-48, "DTC Index"](#).

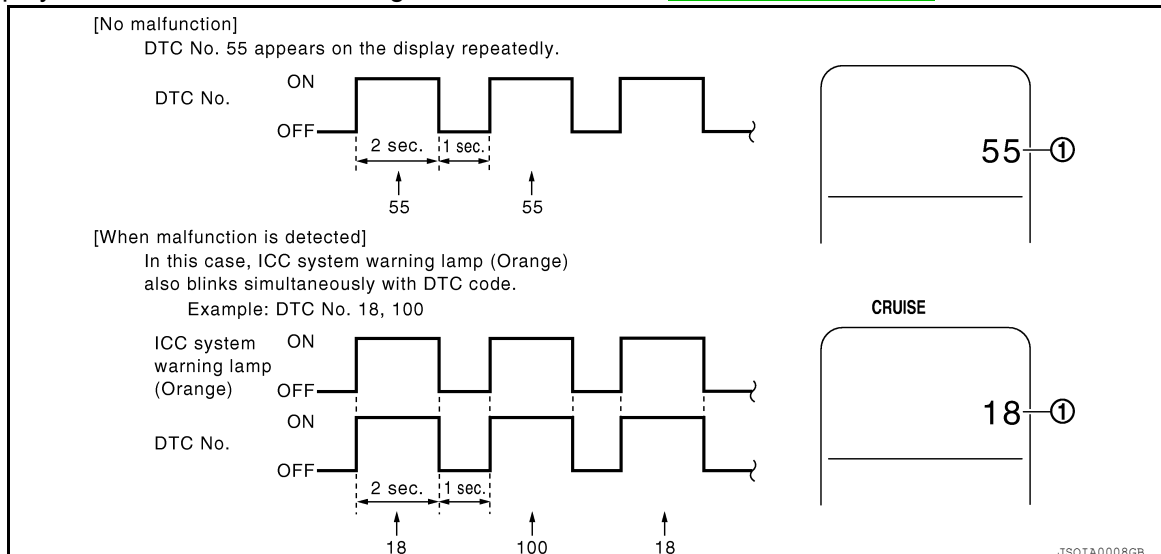

NOTE:

A
B
C
D
E
F
G
H
I
J
K
L
M
N
P

CCS

DIAGNOSIS SYSTEM (ADAS CONTROL UNIT)

[ICC]

< SYSTEM DESCRIPTION >

- It displays for up to 5 minutes and then stops.
- If multiple malfunctions exist, up to 6 DTCs can be stored in memory at the most, and the most recent one is displayed first.

WHEN THE ON BOARD SELF-DIAGNOSIS DOES NOT START

If the on board self-diagnosis does not start, check the following items.

Assumed abnormal part		Inspection item
Information display	Combination meter malfunction	Check that the self-diagnosis function of the combination meter operates. Refer to MWI-15, "INFORMATION DISPLAY : System Description"
ICC steering switch malfunction		Perform the inspection for DTC"C1A06". Refer to DAS-176, "Diagnosis Procedure"
Harness malfunction between ICC steering switch and ECM		
ECM malfunction		
ADAS control unit malfunction		<ul style="list-style-type: none"> • Check power supply and ground circuit of ADAS control unit. Refer to DAS-84, "Diagnosis Procedure". • Perform SELF-DIAGNOSIS for "ICC/ADAS" with CONSULT, and then check the malfunctioning parts. Refer to DAS-48, "DTC Index".

HOW TO ERASE ON BOARD SELF-DIAGNOSIS

1. Turn the ignition switch OFF.
2. Start the engine, and then start the on board self-diagnosis.
3. Press the CANCEL switch 5 times, and then press the DISTANCE switch 5 times under the condition that the on board self-diagnosis starts.

NOTE:

- Complete the operation within 10 seconds after pressing the CANCEL switch first.
- If the operation is not completed within 10 seconds, repeat the procedure from step 1.

4. DTC 55 is displayed after erasing.

NOTE:

DTCs for existing malfunction can not be erased.

5. Turn ignition switch OFF, and finish the diagnosis.

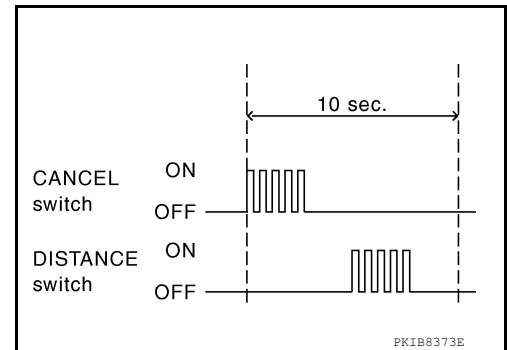

CONSULT Function (ICC/ADAS)

INFOID:000000011558202

CAUTION:

After disconnecting the CONSULT vehicle interface (VI) from the data link connector, the ignition must be cycled OFF → ON (for at least 5 seconds) → OFF. If this step is not performed, the BCM may not go to "sleep mode", potentially causing a discharged battery and a no-start condition.

APPLICATION ITEMS

CONSULT performs the following functions via CAN communication using ADAS control unit.

Diagnosis mode	Description
Self Diagnostic Result	Displays the name of a malfunctioning system stored in the ADAS control unit.
Data Monitor	Displays ADAS control unit input/output data in real time.
Work support	Displays causes of automatic system cancellation occurred during system control.
Active Test	Enables an operational check of a load by transmitting a driving signal from the ADAS control unit to the load.
ECU identification	Displays ADAS control unit part number.
CAN Diag Support Mntr	Displays a reception/transmission state of CAN communication and ITS communication.

SELF DIAGNOSTIC RESULT

Refer to [DAS-48, "DTC Index"](#).

DIAGNOSIS SYSTEM (ADAS CONTROL UNIT)

< SYSTEM DESCRIPTION >

[ICC]

DATA MONITOR

Monitored item [Unit]	ALL SIG (ICC)	MAIN SIG (ICC)	MAIN SIG (LDW/LDP)	MAIN SIG (BSW/BSI)	BCI MAIN	Description
MAIN SW [On/Off]	×	×	×	×		Indicates [On/Off] status as judged from ICC steering switch signal (ECM transmits ICC steering switch signal through CAN communication)
SET/COAST SW [On/Off]	×	×				Indicates [On/Off] status as judged from ICC steering switch signal (ECM transmits ICC steering switch signal through CAN communication)
CANCEL SW [On/Off]	×	×				Indicates [On/Off] status as judged from ICC steering switch signal (ECM transmits ICC steering switch signal through CAN communication)
RESUME/ACC SW [On/Off]	×	×				Indicates [On/Off] status as judged from ICC steering switch signal (ECM transmits ICC steering switch signal through CAN communication)
DISTANCE SW [On/Off]	×					Indicates [On/Off] status as judged from ICC steering switch signal (ECM transmits ICC steering switch signal through CAN communication)
CRUISE OPE [On/Off]	×	×				Indicates whether controlling or not (ON means "controlling")
BRAKE SW [On/Off]	×	×	×	×	×	Indicates [On/Off] status as judged from brake pedal position switch signal (ECM transmits brake pedal position switch signal through CAN communication)
STOP LAMP SW [On/Off]	×	×	×	×	×	Indicates [On/Off] status as judged from stop lamp switch signal (ECM transmits stop lamp switch signal through CAN communication)
IDLE SW [On/Off]	×				×	Indicates [On/Off] status of idle switch read from ADAS control unit through CAN communication (ECM transmits On/Off status through CAN communication)
SET DISTANCE [Short/Mid/Long]	×	×				Indicates set distance memorized in ADAS control unit
CRUISE LAMP [On/Off]	×	×				Indicates [On/Off] status of MAIN switch indicator output
OWN VHCL [On/Off]	×					Indicates [On/Off] status of own vehicle indicator output
VHCL AHEAD [On/Off]	×					Indicates [On/Off] status of vehicle ahead detection indicator output
ICC WARNING [On/Off]	×					Indicates [On/Off] status of ICC system warning lamp output
VHCL SPEED SE [km/h] or [mph]	×	×	×	×	×	Indicates vehicle speed calculated from ADAS control unit through CAN communication [ABS actuator and electric unit (control unit) transmits vehicle speed signal (wheel speed) through CAN communication]
SET VHCL SPD [km/h] or [mph]	×	×				Indicates set vehicle speed memorized in ADAS control unit
BUZZER O/P [On/Off]	×				×	Indicates [On/Off] status of ICC warning chime output
THRTL SENSOR [deg]	×	×				NOTE: The item is displayed, but it is not monitored
ENGINE RPM [rpm]	×					Indicates engine speed read from ADAS control unit through CAN communication (ECM transmits engine speed signal through CAN communication)
WIPER SW [OFF/LOW/HIGH]	×					Indicates wiper [OFF/LOW/HIGH] status (BCM transmits front wiper request signal through CAN communication)
BA WARNING [On/Off]	×					Indicates [On/Off] status of IBA OFF indicator lamp output
STP LMP DRIVE [On/Off]	×	×			×	Indicates [On/Off] status of ICC brake hold relay drive output

A

B

C

D

E

F

G

H

I

J

K

L

M

N

CCS

P

DIAGNOSIS SYSTEM (ADAS CONTROL UNIT)

< SYSTEM DESCRIPTION >

[ICC]

Monitored item [Unit]	ALL SIG (ICC)	MAIN SIG (ICC)	MAIN SIG (LDW/LDP)	MAIN SIG (BSW/BSI)	BCI MAIN	Description
D RANGE SW [On/Off]	×					Indicates [On/Off] status of "D" or "M" positions read from ADAS control unit through CAN communication; ON when position "D" or "M" (TCM transmits shift position signal through CAN communication).
NP RANGE SW [On/Off]	×					Indicates shift position signal read from ADAS control unit through CAN communication (TCM transmits shift position signal through CAN communication)
PKB SW [On/Off]	×					Parking brake switch status [On/Off] judged from the parking brake switch signal that ADAS control unit readout via CAN communication is displayed (Combination meter transmits the parking brake switch signal via CAN communication)
PWR SUP MONI [V]	×	×				Indicates IGN voltage input by ADAS control unit
VHCL SPD AT [km/h] or [mph]	×					Indicates vehicle speed calculated from CVT vehicle speed sensor read from ADAS control unit through CAN communication (TCM transmits CVT vehicle speed sensor signal through CAN communication)
THRTL OPENING [%]	×	×			×	Indicates throttle position read from ADAS control unit through CAN communication (ECM transmits accelerator pedal position signal through CAN communication).
GEAR [1, 2, 3, 4, 5, 6]	×					Indicates CVT gear position read from ADAS control unit through CAN communication (TCM transmits current gear position signal through CAN communication)
MODE SIG [OFF, ICC, ASCD]	×					Indicates the active mode from ICC or ASCD [conventional (fixed speed) cruise control mode]
SET DISP IND [On/Off]	×					Indicates [On/Off] status of SET switch indicator output
DISTANCE [m]	×					Indicates the distance from the vehicle ahead
RELATIVE SPD [m/s]	×					Indicates the relative speed of the vehicle ahead
Camera lost [Detect/Deviate/Both]			×	×		Indicates a lane marker detection state judged from a lane marker detection signal read by the ADAS control unit via ITS communication (Lane camera unit transmits a lane marker signal via ITS communication)
Lane unclear [On/Off]			×	×		Indicates an ON/OFF state of the lane marker. The ON/OFF state is judged from a detected lane condition signal read by the ADAS control unit via ITS communication (The lane camera unit transmits a detected lane condition signal via ITS communication)
STATUS signal [Stnby/Warn/Cancl/Off]			×			Indicates a control state of LDP system
DYNA ASIST SW [On/Off]	×	×		×		Indicates [On/Off] status as judged from ICC steering switch signal (ECM transmits ICC steering switch signal through CAN communication)
DCA ON IND [On/Off]	×					The status [ON/OFF] of DCA system switch indicator output is displayed
DCA VHL AHED [On/Off]	×					The status [ON/OFF] of vehicle ahead detection indicator output in DCA system is displayed
IBA SW [On/Off]	×	×				Indicates [On/Off] status of IBA OFF switch
APA TEMP [°C]	×				×	Accelerator pedal actuator integrated motor temperature that the ADAS control unit readout via ITS communication is displayed (Accelerator pedal actuator transmits the integrated motor temperature via ITS communication)

DIAGNOSIS SYSTEM (ADAS CONTROL UNIT)

< SYSTEM DESCRIPTION >

[ICC]

Monitored item [Unit]	ALL SIG (ICC)	MAIN SIG (ICC)	MAIN SIG (LDW/LDP)	MAIN SIG (BSW/BSI)	BCI MAIN	Description
APA PWR [V]	×				×	Accelerator pedal actuator power supply voltage that the ADAS control unit read-out via ITS communication is displayed (Accelerator pedal actuator transmits the power supply voltage via ITS communication)
FCW SYSTEM ON [On/Off]	×	×				Indicates [On/Off] status of FCW system
LDW SYSTEM ON [On/Off]			×			Indicates [On/Off] status of LDW system
LDW ON LAMP [On/Off]			×			Indicates [On/Off] status of warning systems ON indicator output
LDP ON IND [On/Off]			×			Indicates [On/Off] status of LDP ON indicator lamp (Green) output
LANE DPRT W/L [On/Off]			×			Indicates [On/Off] status of lane departure warning lamp (Yellow) output
LDW BUZER OUTPUT [On/Off]			×			Indicates [On/Off] status of warning buzzer output
LDP SYSTEM ON [On/Off]			×			Indicates [On/Off] status of LDP system
READY signal [On/Off]			×			Indicates LDP system settings
Shift position [Off, P, R, N, D, M/T1 - 7]			×	×	×	Indicates shift position read from ADAS control unit through CAN communication (TCM transmits shift position signal through CAN communication)
Turn signal [OFF/LH/RH/LH&RH]			×	×		Indicates turn signal operation status read from ADAS control unit through CAN communication (BCM transmits turn indicator signal through CAN communication)
SIDE G [G]			×	×		Indicates lateral G acting on the vehicle. This lateral G is judged from a side G sensor signal read by ADAS control unit via CAN communication (The ABS actuator and electric unit (control unit) transmits a side G sensor signal via CAN communication)
FUNC ITEM(FCW)	×	×	×	×		Indicates systems which can be set to ON/OFF by selecting "Driver Assistance" ⇒ "Driving aids" of the navigation system FCW: Distance Control Assist (DCA), Lane Departure Prevention (LDP) and Blind Spot Intervention
FUNC ITEM(LDW)	×	×	×	×		Indicates systems which can be set to ON/OFF by selecting "Driver Assistance" ⇒ "Driving aids" of the navigation system LDW: Distance Control Assist (DCA), Lane Departure Prevention (LDP) and Blind Spot Intervention
FUNC ITEM(BSW)	×	×	×	×		Indicates systems which can be set to ON/OFF by selecting "Driver Assistance" ⇒ "Driving aids" of the navigation system BSW: Distance Control Assist (DCA), Lane Departure Prevention (LDP) and Blind Spot Intervention
FUNC ITEM (NV-ICC) [Off]	×	×	×	×		NOTE: The item is displayed, but it is not monitored
FUNC ITEM (NV-DCA) [Off]	×	×	×	×		NOTE: The item is displayed, but it is not monitored
DCA SELECT [On/Off]	×	×	×	×		Indicates an ON/OFF state of DCA system. DCA system can be set to ON/OFF by selecting "Driver Assistance" ⇒ "Driving aids" of the navigation system
LDP SELECT [On/Off]	×	×	×	×		Indicates an ON/OFF state of LDP system. LDP system can be set to ON/OFF by selecting "Driver Assistance" ⇒ "Driving aids" of the navigation system

A
B
C
D
E
F
G
H
I
J
K
L
M
N
P

CCS

DIAGNOSIS SYSTEM (ADAS CONTROL UNIT)

< SYSTEM DESCRIPTION >

[ICC]

Monitored item [Unit]	ALL SIG (ICC)	MAIN SIG (ICC)	MAIN SIG (LDW/LDP)	MAIN SIG (BSW/BSI)	BCI MAIN	Description
BSI SELECT [On/Off]	×	×	×	×		Indicates an ON/OFF state of Blind Spot Intervention system. Blind Spot Intervention system can be set to ON/OFF by selecting "Driver Assistance" ⇒ "Driving aids" of the navigation system
DRIVE MODE STATS [SNO/ECO/STD/SPT]	×	×	×	×		Indicates [On/Off] status of warning systems switch
WARN SYS SW [On/Off]	×	×	×	×		Indicates [On/Off] status of warning systems switch
BSW/BSI WARN LMP [On/Off]				×		Indicates [On/Off] status of Blind Spot Warning/Blind Spot Intervention warning lamp output
BSI ON IND [On/Off]				×		Indicates [On/Off] status of Blind Spot Intervention ON indicator output
BSW SYSTEM ON [On/Off]				×		Indicates [On/Off] status of BSW system
BSI SYSTEM ON [On/Off]				×		Indicates [On/Off] status of Blind Spot Intervention system
BCI SYSTEM ON [On/Off]					×	Indicates [On/Off] status of Backup Collision Intervention system
BCI SWITCH [On/Off]					×	Indicates [On/Off] status of Backup Collision Intervention system switch
LDP WARNING INDICA- TOR [On/Off]			×			Indicates [On/Off] status of Lane Departure Prevention system failure lamp
LDW ON INDICATOR [On/Off]			×			Indicates [On/Off] status of LDW system
LDW WARNING INDICA- TOR [On/Off]			×			Indicates [On/Off] status of Lane Departure Warning system failure lamp
SYSTEM CANCEL MES- SAGE [Request/No Request]	×	×	×	×		Indicates system cancel message request
CAMERA HI TEMP MSG [On/Off]			×	×		Indicates high temperature message has been received
ITS Setting Item(DCA) [On/Off]	×	×	×	×		Indicates [On/Off] status of Distance Control Assist warning lamp output
ITS Setting Item(LDP) [On/Off]	×	×	×	×		Indicates [On/Off] status of Lane Departure Prevention warning lamp output
ITS Setting Item(BSI) [On/Off]	×	×	×	×		Indicates [On/Off] status of Blind Spot Intervention system
BSI WARNING INDICA- TOR [On/Off]				×		Indicates [On/Off] status of Blind Spot Intervention warning lamp indicator
BSW ON INDICATOR [On/Off]				×		Indicates [On/Off] status of BSW system
BSW IND BRIGHTNESS [Bright/Not Bright]				×		Indicates BSW warning lamp indicator brightness level
WARN REQ [On/Off]			×			Indicates an ADAS control unit judged warning state (ON/OFF) of LDP system

DIAGNOSIS SYSTEM (ADAS CONTROL UNIT)

< SYSTEM DESCRIPTION >

[ICC]

WORK SUPPORT

Work support items	Description
CAUSE OF AUTO-CANCEL 1	Displays causes of automatic system cancellation occurred during control of the following systems <ul style="list-style-type: none"> • Vehicle-to-vehicle distance control mode • Conventional (fixed speed) cruise control mode • Distance Control Assist (DCA)
CAUSE OF AUTO-CANCEL 2	Displays causes of automatic system cancellation occurred during control of the following systems <ul style="list-style-type: none"> • Lane Departure Prevention (LDP) • Blind Spot Intervention
CAUSE OF AUTO-CANCEL 3	Displays causes of automatic system cancellation occurred during control of the following system <ul style="list-style-type: none"> • Backup Collision Intervention

NOTE:

- Causes of the maximum five cancellations (system cancel) are displayed.
- The displayed cancellation causes display the number of the ignition switch ON/OFF up to 254. It is fixed to 254 if it is over 254. It returns to 0 when the same cancellation cause is detected again.

Display Items for The Cause of Automatic Cancellation 1

Cause of cancellation	Vehicle-to-vehicle distance control mode	Conventional (fixed speed) cruise control mode	Distance Control Assist	Description
OPERATING ABS	×		×	ABS function was operated
OPERATING TCS	×	×	×	TCS function was operated
OPERATING VDC	×	×	×	VDC function was operated
ECM CIRCUIT	×	×		ECM did not permit ICC operation
OPE SW VOLT CIRC	×	×	×	The ICC steering switch input voltage is not within standard range
LASER TEMP	×		×	Temperature around ICC sensor became low
SNOW MODE SW	×		×	SNOW mode switch was pressed
OP SW DOUBLE TOUCH	×	×		ICC steering switches were pressed at the same time
VHCL SPD DOWN	×	×	×	Vehicle speed lower than the speed as follows <ul style="list-style-type: none"> • Vehicle-to-vehicle distance control mode is 24 km/h (15 MPH) • Conventional (fixed speed) cruise control mode is 22 km/h (14 MPH)
WHL SPD ELEC NOISE	×	×	×	Wheel speed sensor signal caught electromagnetic noise
VDC/TCS OFF SW	×		×	VDC OFF switch was pressed
VHCL SPD UNMATCH	×	×	×	Wheel speed became different from CVT vehicle speed
FR RADAR BLOCKED	×		×	The front bumper near the ICC sensor is blocked or dirty
TIRE SLIP	×	×		Wheel slipped

DIAGNOSIS SYSTEM (ADAS CONTROL UNIT)

< SYSTEM DESCRIPTION >

[ICC]

IGN LOW VOLT	×	×	×	Decrease in ADAS control unit IGN voltage
PARKING BRAKE ON	×	×		The parking brake is engaged
WHEEL SPD UNMATCH	×	×	×	The wheel speeds of 4 wheels are out of the specified values
INCHING LOST	×			A vehicle ahead is not detected during the following driving when the vehicle speed is approximately 24 km/h (15 MPH) or less
CAN COMM ERROR	×	×	×	ADAS control unit received an abnormal signal with CAN communication
ABS/TCS/VDC CIRC	×	×	×	An abnormal condition occurs in VDC/TCS/ABS system
ECD CIRCUIT	×	×	×	An abnormal condition occurs in ECD system
ASCD VHCL SPD DTAC		×		Vehicle speed is detached from set vehicle speed
ASCD DOUBLE COMD		×		Cancel switch and operation switch are detected simultaneously
APA HI TEMP			×	The accelerator pedal actuator integrated motor temperature is high
ICC SENSOR CAN COMM ERR	×		×	Communication error between ADAS control unit and the ICC sensor
ABS WARNING LAMP	×		×	ABS warning lamp ON
NO RECORD	×	×	×	—

Display Items for The Cause of Automatic Cancellation 2

Cause of cancellation	Lane departure prevention	Blind spot intervention	Description
OPE VDC/TCS/ABS 1	×		The activation of VDC, TCS, or ABS during LDP system control
Vehicle dynamics	×		Vehicle behavior exceeds specified value
Steering speed	×		Steering speed was more than the specified value in evasive direction
End by yaw angle	×		Yaw angle was the end of LDP control
Departure yaw large	×		Detected more than the specified value of yaw angle in departure direction
ICC WARNING	×		Target approach warning of ICC system, IBA system, or FCW system was activated
CURVATURE	×		Road curve was more than the specified value
Steering angle large	×		Steering angle was more than the specified value
Brake is operated	×		Brake pedal was operated
IGN LOW VOLT	×		Decrease in ADAS control unit IGN voltage
Lateral offset	×		Distance of vehicle and lane was detached in lateral direction more than the specified value
Lane marker lost	×		Lane camera unit lost the trace of lane marker
Lane marker unclear	×		Detected lane marker was unclear
Yaw acceleration	×		Detected yawing speed was more than the specified value
Deceleration large	×		Deceleration in a longitudinal direction was more than the specified value
Accel is operated	×		Accelerator pedal was depressed
Departure steering	×		Steering wheel was steered more than the specified value in departure direction
Evasive steering	×		Steering wheel was steered more than the specified value in the evasive direction
R range	×		Selector lever was operated to R range
Parking brake drift	×		Rear wheels lock was detected

DIAGNOSIS SYSTEM (ADAS CONTROL UNIT)

< SYSTEM DESCRIPTION >

[ICC]

Cause of cancellation	Lane departure prevention	Blind spot intervention	Description	
Not operating condition	×		Did not meet the operating condition (vehicle speed, turn signal operation, etc.)	A
SNOW MODE SW	×		SNOW mode switch was pressed	B
VDC OFF SW	×		VDC OFF switch was pressed	C
OPE VDC/ABS 2	×		The activation of VDC or ABS during a standby time of LDP system control	D
BSI WARNING	×		Blind Spot Intervention system was activated	E
BSI) OPE VDC/TCS/ ABS 1		×	The activation of VDC, TCS, or ABS during Blind Spot Intervention system control	F
BSI) Vehicle dynamics		×	Vehicle behavior exceeds specified value	G
BSI) Steering speed		×	Steering speed was more than the specified value in evasive direction	H
BSI) End by yaw angle		×	Yaw angle was the end of Blind Spot Intervention control	I
BSI) Departure yaw large		×	Detected more than the specified value of yaw angle in departure direction	J
BSI) ICC WARNING		×	Target approach warning of ICC system, IBA system or FCW system was activated	K
BSI) CURVATURE		×	Road curve was more than the specified value	L
BSI) Steering angle large		×	Steering angle was more than the specified value	M
BSI) Brake is operated		×	Brake pedal was operated	N
BSI) IGN LOW VOLT		×	Decrease in ADAS control unit IGN voltage	O
BSI) Lateral offset		×	Distance of vehicle and lane was detached in lateral direction more than the specified	P
BSI) Lane marker lost		×	Lane camera unit lost the trace of lane marker	Q
BSI) Lane marker unclear		×	Detected lane marker was unclear	R
BSI) Yaw acceleration		×	Detected yawing speed was more than the specified value	S
BSI) Deceleration large		×	Deceleration in a longitudinal direction was more than the specified value	T
BSI) Accel is operated		×	Accelerator pedal was depressed	U
BSI) Departure steering		×	Steering wheel was steered more than the specified value in departure direction	V
BSI) Evasive steering		×	Steering wheel was steered more than the specified value in the evasive direction	W
BSI) R range		×	Selector lever was operated to R range	X
BSI) Parking brake drift		×	Rear wheels lock was detected	Y
BSI) SNOW MODE SW		×	SNOW mode switch was pressed	Z
BSI) VDC OFF SW		×	VDC OFF switch was pressed	AA
BSI) OPE VDC/ABS 2		×	The activation of VDC or ABS during a standby time of Blind Spot Intervention system control	AB
BSI) Not operating condition		×	Did not meet the operating condition (vehicle speed, turn signal operation, etc.)	AC
Side Radar Lost		×	Unrecognized side radar LH or RH by the ADAS control unit	AD
NO RECORD	×	×	—	AE

Display Items for The Cause of Automatic Cancellation 3

DIAGNOSIS SYSTEM (ADAS CONTROL UNIT)

< SYSTEM DESCRIPTION >

[ICC]

Cause of cancellation	Backup Collision Intervention	Description
OPERATING WIPER	×	The wiper operates at HI (it includes when the wiper is operated at HI with the wiper switch AUTO position)
OPERATING ABS	×	ABS function was operated
OPERATING TCS	×	TCS function was operated
OPERATING VDC	×	VDC function was operated
ECM CIRCUIT	×	ECM did not permit ICC operation
SNOW MODE SW	×	SNOW mode switch was pressed
VDC/TCS OFF SW	×	VDC OFF switch was pressed
VHCL SPD UNMATCH	×	Wheel speed became different from CVT vehicle speed
TIRE SLIP	×	Wheel slipped
IGN LOW VOLT	×	Decrease in ADAS control unit IGN voltage
PARKING BRAKE ON	×	The parking brake is engaged
WHEEL SPD UNMATCH	×	The wheel speeds of 4 wheels are out of the specified values
CAN COMM ERROR	×	ADAS control unit received an abnormal signal with CAN communication
ABS/TCS/VDC CIRC	×	An abnormal condition occurs in VDC/TCS/ABS system
ECD CIRCUIT	×	An abnormal condition occurs in ECD system
APA HI TEMP		The accelerator pedal actuator integrated motor temperature is high
ABS WARNING LAMP	×	ABS warning lamp ON
Brake is operated	×	Brake pedal was operated
Accel is operated	×	Accelerator pedal was depressed
SNOW MODE SW	×	DMS switch SNOW mode was selected
VDC OFF SW	×	VDC OFF switch was pressed
Side Radar Lost	×	Unrecognized side radar LH or RH by the ADAS control unit
NO RECORD	×	—

ACTIVE TEST

CAUTION:

- Never perform “Active Test” while driving the vehicle.
- The “Active Test” cannot be performed when the following systems warning lamp is illuminated.
 - ICC system warning lamp
 - Lane departure warning lamp
 - Blind Spot Warning/Blind Spot Intervention warning lamp
 - IBA OFF indicator lamp (IBA system ON)
- Shift the selector lever to “P” position, and then perform the test.

Test item	Description
BRAKE ACTUATOR	Activates the brake by an arbitrary operation
ICC BUZZER	Sounds a buzzer used for following systems by arbitrarily operating ON/OFF <ul style="list-style-type: none"> • Intelligent Cruise Control (ICC) • Distance Control Assist (DCA) • Forward Collision Warning (FCW) • Intelligent Brake Assist (IBA)

DIAGNOSIS SYSTEM (ADAS CONTROL UNIT)

< SYSTEM DESCRIPTION >

[ICC]

Test item	Description
METER LAMP	The ICC system warning lamp, MAIN switch indicator and IBA OFF indicator lamp can be illuminated by ON/OFF operations as necessary
STOP LAMP	The ICC brake hold relay can be operated by ON/OFF operations as necessary, and the stop lamp can be illuminated
ACTIVE PEDAL	The accelerator pedal actuator can be operated as necessary
DCA INDICATOR	The DCA system switch indicator can be illuminated by ON/OFF operations as necessary
LDP BUZZER	Sounds a buzzer used for following systems by arbitrarily operating ON/OFF <ul style="list-style-type: none"> • Lane Departure Warning (LDW) • Lane Departure Prevention (LDP) • Blind Spot Warning (BSW) • Blind Spot Intervention
WARNING SYSTEM IND	Warning systems ON indicator (on warning systems switch) can be illuminated by ON/OFF operations as necessary
LDP ON IND	The LDP ON indicator lamp can be illuminated by ON/OFF operations as necessary
LANE DEPARTURE W/L	The Lane departure warning lamp can be illuminated by ON/OFF operations as necessary
BSW/BSI WARNING LAMP	The Blind Spot Warning/Blind Spot Intervention warning lamp can be illuminated by ON/OFF operations as necessary
BSI ON INDICATOR	The Blind Spot Intervention ON indicator can be illuminated by ON/OFF operations as necessary
LDW ON INDICATOR	The LDW ON indicator lamp can be illuminated by ON/OFF operations as necessary
BSW ON INDICATOR	The BSW ON indicator lamp can be illuminated by ON/OFF operations as necessary

BRAKE ACTUATOR

NOTE:

The test can be performed only when the engine is running.

Test item	Operation	Description	"PRESS SENS" value
BRAKE ACTUATOR	MODE1	Transmits the brake fluid pressure control signal to the ABS actuator and electric unit (control unit) via CAN communication	10 bar
	MODE2		20 bar
	MODE3		30 bar
	Test start	Starts the tests of "MODE1", "MODE2" and "MODE3"	—
	Reset	Stops transmitting the brake fluid pressure control signal below to end the test	—
	End	Returns to the "SELECT TEST ITEM" screen	—

NOTE:

The test is finished in 10 seconds after starting

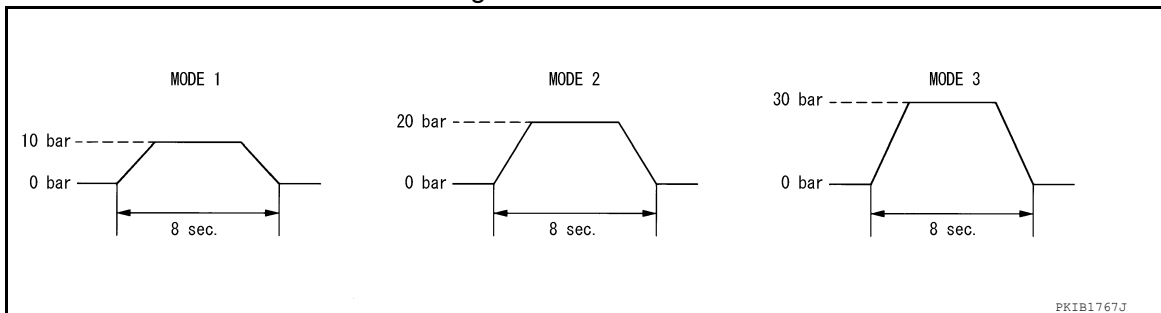

ICC BUZZER

A
B
C
D
E
F
G
H
I
J
K
L
M
N
P



DIAGNOSIS SYSTEM (ADAS CONTROL UNIT)

< SYSTEM DESCRIPTION >

[ICC]

Test item	Operation	Description	ICC warning chime operation sound
ICC BUZZER	MODE1	Transmits the buzzer output signals to the combination meter via CAN communication	Intermittent beep sound
	Test start	Starts the tests of "MODE1"	—
	Reset	Stops transmitting the buzzer output signal below to end the test	—
	End	Returns to the "SELECT TEST ITEM" screen	—

METER LAMP

NOTE:

The test can be performed only when the engine is running.

Test item	Operation	Description	<ul style="list-style-type: none"> • MAIN switch indicator • ICC system warning lamp • IBA OFF indicator lamp
METER LAMP	Off	Stops sending the following signals to exit from the test <ul style="list-style-type: none"> • Meter display signal • ICC warning lamp signal • IBA OFF indicator lamp signal 	OFF
	On	Transmits the following signals to the combination meter via CAN communication <ul style="list-style-type: none"> • Meter display signal • ICC warning lamp signal • IBA OFF indicator lamp signal 	ON

STOP LAMP

Test item	Operation	Description	Stop lamp
STOP LAMP	Off	Stops transmitting the ICC brake hold relay drive signal below to end the test	OFF
	On	Transmits the ICC brake hold relay drive signal	ON

ACTIVE PEDAL

CAUTION:

- Shift the selector lever to "P" position, and then perform the test.
- Never depress the accelerator pedal excessively. (The engine speed may rise unexpectedly when finishing the test.)

NOTE:

- Depress the accelerator pedal to check when performing the test.
- The test can be performed only when the engine is running.

Test item	Operation	Description	Accelerator pedal operation
Active Pedal	MODE1	Transmit the accelerator pedal feedback force control signal to the accelerator pedal actuator via ITS communication.	Constant with a force of 25 N for 8 seconds
	MODE2		Constant with a force of 15 N for 8 seconds
	MODE3		Change up to a force of 25 N for 8 seconds
	MODE4		Change up to a force of 15 N for 8 seconds
	Test start	Starts the tests of "MODE1", "MODE2", "MODE3" and "MODE4"	—
	Reset	Stops transmitting the accelerator pedal feedback force control signal below to end the test.	—
	End	Returns to the "SELECT TEST ITEM" screen	—

DIAGNOSIS SYSTEM (ADAS CONTROL UNIT)

< SYSTEM DESCRIPTION >

[ICC]

NOTE:

The test is finished in 10 seconds after starting

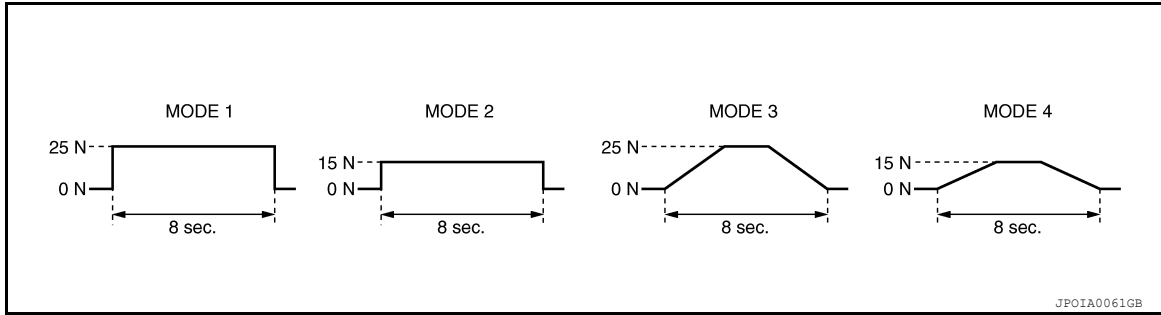

DCA INDICATOR

NOTE:

The test can be performed only when the engine is running.

Test item	Operation	Description	DCA system switch indicator
DCA INDICATOR	Off	Stops transmitting the DCA system switch indicator signal below to end the test	—
	On	Transmits the DCA system switch indicator signal to the combination meter via CAN communication	ON

LDP BUZZER

Test item	Operation	Description	Warning buzzer
LDP BUZZER	Off	Stops transmitting the warning buzzer signal below to end the test	—
	On	Transmits the warning buzzer signal to the warning buzzer	ON

WARNING SYSTEM IND

Test item	Operation	Description	Warning systems ON indicator
WARNING SYSTEM IND	Off	Stops transmitting the warning systems ON indicator signal below to end the test	—
	On	Transmits the warning systems ON indicator signal to the warning systems ON indicator	ON

LDP ON IND

Test item	Operation	Description	LDP ON indicator lamp (Green)
LDP ON IND	Off	Stops transmitting the LDP ON indicator lamp signal below to end the test	—
	On	Transmits the LDP ON indicator lamp signal to the combination meter via CAN communication	ON

LANE DEPARTURE W/L

Test item	Operation	Description	Lane departure warning lamp (Yellow)
LANE DEPARTURE W/L	Off	Stops transmitting the lane departure warning lamp signal below to end the test	—
	On	Transmits the lane departure warning lamp signal to the combination meter via CAN communication	ON

A
B
C
D
E
F
G
H
I
J
K
L
M
N
P

CCS

DIAGNOSIS SYSTEM (ADAS CONTROL UNIT)

< SYSTEM DESCRIPTION >

[ICC]

BSW/BSI WARNING LAMP

Test item	Operation	Description	Blind Spot Warning/Blind Spot Intervention warning lamp (Yellow)
BSW/BSI WARNING LAMP	Off	Stops transmitting the Blind Spot Warning/Blind Spot Intervention warning lamp signal below to end the test	—
	On	Transmits the Blind Spot Warning/Blind Spot Intervention warning lamp signal to the combination meter via CAN communication	ON

BSI ON INDICATOR

Test item	Operation	Description	Blind Spot Intervention ON indicator lamp (Green)
BSI ON INDICATOR	Off	Stops transmitting the Blind Spot Intervention ON indicator signal below to end the test	—
	On	Transmits the Blind Spot Intervention ON indicator signal to the combination meter via CAN communication	ON

LDW ON INDICATOR

Test item	Operation	Description	Lane Departure Warning ON indicator lamp (Yellow)
LDW ON INDICATOR	Off	Stops transmitting the Lane Departure Warning ON indicator signal below to end the test	—
	On	Transmits the Lane Departure Warning ON indicator signal to the combination meter via CAN communication	ON

BSW ON INDICATOR

Test item	Operation	Description	Blind Spot Warning ON indicator lamp (Yellow)
BSW ON INDICATOR	Off	Stops transmitting the Blind Spot Warning ON indicator signal below to end the test	—
	On	Transmits the Blind Spot Warning ON indicator signal to the warning lamp on the door	ON

ECU IDENTIFICATION

ADAS control unit part number is displayed.

DIAGNOSIS SYSTEM (ICC SENSOR)

< SYSTEM DESCRIPTION >

[ICC]

DIAGNOSIS SYSTEM (ICC SENSOR)

CONSULT Function (LASER/RADAR)

INFOID:000000011132059

CAUTION:

After disconnecting the CONSULT vehicle interface (VI) from the data link connector, the ignition must be cycled OFF → ON (for at least 5 seconds) → OFF. If this step is not performed, the BCM may not go to “sleep mode”, potentially causing a discharged battery and a no-start condition.

APPLICATION ITEMS

CONSULT performs the following functions via CAN communication with ADAS control unit and the communication with ICC sensor.

Diagnosis mode	Description
Self Diagnostic Result	Displays malfunctioning system memorized in ICC sensor
Data Monitor	Displays real-time input/output data of ICC sensor
Work support	It can monitor the adjustment direction indication in order to perform the radar adjustment operation smoothly
ECU identification	Displays ICC sensor part number
CAN Diag Support Monitor	The results of transmit/receive diagnosis of ITS communication can be read

SELF DIAGNOSTIC RESULT

Refer to [CCS-66. "DTC Index"](#).

DATA MONITOR

Monitored item [Unit]	Description
VHCL SPEED SE [km/h] or [mph]	Vehicle speed judged from a vehicle speed signal read by the ICC sensor via ITS communication is displayed [ADAS control unit receives a vehicle speed signal from ABS actuator and electric unit (control unit) via CAN communication and transmits the calculated vehicle speed to ICC sensor via ITS communication]
YAW RATE [deg/s]	Indicates yaw rate read from ADAS control unit through ITS communication (ADAS control unit receives yaw rate signal from ABS actuator and electric unit (control unit) via CAN communication and transmits yaw rate calculated by the ADAS control unit) Yaw rate judged from a yaw rate signal read by ICC sensor via ITS communication is displayed [ADAS control unit receives a yaw rate signal from ABS actuator and electric unit (control unit) via CAN communication and transmits the calculated yaw rate to ICC sensor via ITS communication]
PWR SUP MONI [V]	Indicates IGN voltage input by ICC sensor
DISTANCE [m]	Indicates the distance from the vehicle ahead
RELATIVE SPD [m/s]	Indicates the relative speed of the vehicle ahead
RADAR OFFSET [m]	NOTE: The item is indicated, but not used
RADAR HEIGHT [m]	NOTE: The item is indicated, but not used
STEERING ANGLE [deg]	The steering angle is displayed
STRG ANGLE SPEED [deg/s]	The steering angle speed is displayed
L/R ADJUST [deg]	Indicates a horizontal correction value of the radar
U/D ADJUST [deg]	Indicates a vertical correction value of the radar

DIAGNOSIS SYSTEM (ICC SENSOR)

< SYSTEM DESCRIPTION >

[ICC]

WORK SUPPORT

Work support items	Description
MILLIWAVE RADAR ADJUST	Outputs millimeter waves, calculates the displacement in radar direction, and indicates an adjustment direction

ICC sensor Adjust

Refer to [CCS-89, "Description"](#).

ECU IDENTIFICATION

ICC sensor part number is displayed.

ADAS CONTROL UNIT

< ECU DIAGNOSIS INFORMATION >

[ICC]

ECU DIAGNOSIS INFORMATION

ADAS CONTROL UNIT

Reference Value

INFOID:0000000011558203

VALUES ON THE DIAGNOSIS TOOL

Monitor item	Condition	Value/Status	
MAIN SW	Ignition switch ON	When MAIN switch is pressed	On
		When MAIN switch is not pressed	Off
SET/COAST SW	Ignition switch ON	When SET/COAST switch is pressed	On
		When SET/COAST switch is not pressed	Off
CANCEL SW	Ignition switch ON	When CANCEL switch is pressed	On
		When CANCEL switch is not pressed	Off
RESUME/ACC SW	Ignition switch ON	When RESUME/ACCELERATE switch is pressed	On
		When RESUME/ACCELERATE switch is not pressed	Off
DISTANCE SW	Ignition switch ON	When DISTANCE switch is pressed	On
		When DISTANCE switch is not pressed	Off
CRUISE OPE	Drive the vehicle and activate the vehicle-to-vehicle distance control mode	When ICC system is controlling	On
		When ICC system is not controlling	Off
BRAKE SW	Ignition switch ON	When brake pedal is depressed	Off
		When brake pedal is not depressed	On
STOP LAMP SW	Ignition switch ON	When brake pedal is depressed	On
		When brake pedal is not depressed	Off
IDLE SW	Engine running	Idling	On
		Except idling (depress accelerator pedal)	Off
SET DISTANCE	<ul style="list-style-type: none"> Start the engine and turn the ICC system ON Press the DISTANCE switch to change the vehicle-to-vehicle distance setting 	When set to "long"	Long
		When set to "middle"	Mid
		When set to "short"	Short
CRUISE LAMP	Start the engine and press MAIN switch	ICC system ON (MAIN switch indicator ON)	On
		ICC system OFF (MAIN switch indicator OFF)	Off
OWN VHCL	Start the engine and press MAIN switch	ICC system ON (Own vehicle indicator ON)	On
		ICC system OFF (Own vehicle indicator OFF)	Off
VHCL AHEAD	Drive the vehicle and activate the vehicle-to-vehicle distance control mode	When a vehicle ahead is detected (vehicle ahead detection indicator ON)	On
		When a vehicle ahead is not detected (vehicle ahead detection indicator OFF)	Off
ICC WARNING	Start the engine and press MAIN switch	When ICC system is malfunctioning (ICC system warning lamp ON)	On
		When ICC system is normal (ICC system warning lamp OFF)	Off

A
B
C
D
E
F
G
H
I
J
K
L
M
N
P

CCS

ADAS CONTROL UNIT

< ECU DIAGNOSIS INFORMATION >

[ICC]

Monitor item	Condition		Value/Status
VHCL SPEED SE	While driving		Displays a vehicle speed calculated by the ADAS control unit
SET VHCL SPD	While driving	When vehicle speed is set	Displays the set vehicle speed
BUZZER O/P	Engine running	When the buzzer of the following system operates <ul style="list-style-type: none"> • Vehicle-to-vehicle distance control mode • DCA system • FCW system • IBA system 	On
		When the buzzer of the following system not operates <ul style="list-style-type: none"> • Vehicle-to-vehicle distance control mode • DCA system • FCW system • IBA system 	Off
THRTL SENSOR	NOTE: The item is indicated, but not monitored		0.0
ENGINE RPM	Engine running		Equivalent to tachometer reading
WIPER SW	Ignition switch ON	Wiper not operating	Off
		Wiper LO operation	Low
		Wiper HI operation	High
BA WARNING	Engine running	IBA OFF indicator lamp ON <ul style="list-style-type: none"> • When IBA system is malfunctioning • When IBA system is turned to OFF 	On
		IBA OFF indicator lamp OFF <ul style="list-style-type: none"> • When IBA system is normal • When IBA system is turned to ON 	Off
STP LMP DRIVE	Drive the vehicle and activate the vehicle-to-vehicle distance control mode	When ICC brake hold relay is activated	On
		When ICC brake hold relay is not activated	Off
D RANGE SW	Engine running	When the selector lever is in "D" position or manual mode	On
		When the selector lever is in any position other than "D" or manual mode	Off
NP RANGE SW	Engine running	When the selector lever is in "N", "P" position	On
		When the selector lever is in any position other than "N", "P"	Off
PKB SW	Ignition switch ON	When the parking brake is applied	On
		When the parking brake is released	Off
PWR SUP MONI	Engine running		Power supply voltage value of ADAS control unit
VHCL SPD AT	While driving		Value of CVT vehicle speed sensor signal
THRTL OPENING	Engine running	Depress accelerator pedal	Displays the throttle position

ADAS CONTROL UNIT

< ECU DIAGNOSIS INFORMATION >

[ICC]

Monitor item	Condition		Value/Status
GEAR	While driving		Displays the gear position
MODE SIG	Start the engine and press MAIN switch	When ICC system is deactivated	Off
		When vehicle-to-vehicle distance control mode is activated	ICC
		When conventional (fixed speed) cruise control mode is activated	ASCD
SET DISP IND	<ul style="list-style-type: none"> • Drive the vehicle and activate the conventional (fixed speed) cruise control mode • Press SET/COAST switch 	SET switch indicator ON	On
		SET switch indicator OFF	Off
DISTANCE	Drive the vehicle and activate the vehicle-to-vehicle distance control mode	When a vehicle ahead is detected	Displays the distance from the preceding vehicle
		When a vehicle ahead is not detected	0.0
RELATIVE SPD	Drive the vehicle and activate the vehicle-to-vehicle distance control mode	When a vehicle ahead is detected	Displays the relative speed.
		When a vehicle ahead is not detected	0.0
Camera lost	Drive the vehicle and activate the LDW system, LDP system or Blind Spot Intervention system	Both side lane markers are detected	Detect
		Deviate side lane marker is lost	Deviate
		Both side lane markers are lost	Both
Lane unclear	While driving	Lane marker is unclear	On
		Lane marker is clear	Off
STATUS signal	Drive the vehicle with the LDP system turned ON	When the LDP system is ON	Stnby
		When the LDP system is operating	Warn
		When the LDP system is canceled	Cancl
		When the LDP system is OFF	Off
DYNA ASIST SW	Ignition switch ON	When dynamic driver assistance switch is pressed	On
		When dynamic driver assistance switch is not pressed	Off
DCA ON IND	Start the engine and press dynamic driver assistance switch (When DCA system setting is ON)	DCA system OFF (DCA system switch indicator OFF)	Off
		DCA system ON (DCA system switch indicator ON)	On
DCA VHL AHED	Drive the vehicle and activate the DCA system	When a vehicle ahead is not detected (vehicle ahead detection indicator OFF)	Off
		When a vehicle ahead is detected (vehicle ahead detection indicator ON)	On
IBA SW	Ignition switch ON	When the IBA OFF switch is pressed	On
		When the IBA OFF switch is not pressed	Off
APA TEMP	Engine running		Display the accelerator pedal actuator integrated motor temperature
APA PWR	Ignition switch ON		Power supply voltage value of accelerator pedal actuator

A
B
C
D
E
F
G
H
I
J
K
L
M
N
P

CCS

ADAS CONTROL UNIT

< ECU DIAGNOSIS INFORMATION >

[ICC]

Monitor item	Condition		Value/Status
FCW SYSTEM ON	Ignition switch ON	When the FCW system is ON (Warning systems ON indicator ON)	On
		When the FCW system is OFF (Warning systems ON indicator OFF)	Off
LDW SYSTEM ON	Ignition switch ON	When the LDW system is ON (Warning systems ON indicator ON)	On
		When the LDW system is OFF (Warning systems ON indicator OFF)	Off
LDW ON LAMP	Ignition switch ON	Warning systems ON indicator ON	On
		Warning systems ON indicator OFF	Off
LDP ON IND	Start the engine and press dynamic driver assistance switch (When LDP system setting is ON)	LDP ON indicator lamp ON	On
		LDP ON indicator lamp OFF	Off
LANE DPRT W/L	Drive the vehicle and activate the LDW system or LDP system	Lane departure warning lamp ON	On
		Lane departure warning lamp OFF	Off
LDW BUZER OUTPUT	Drive the vehicle and activate the LDW/LDP system or Blind Spot Warning/Blind Spot Intervention system	When the buzzer of the following system operates • LDW/LDP system • Blind Spot Warning/Blind Spot Intervention system	On
		When the buzzer of the following system does not operate • LDW/LDP system • Blind Spot Warning/Blind Spot Intervention system	Off
LDP SYSTEM ON	Start the engine and press dynamic driver assistance switch (When LDP system setting is ON)	When the LDP system is ON	On
		When the LDP system is OFF	Off
READY signal	Start the engine and press dynamic driver assistance switch (When LDP system setting is ON)	When the LDP system is ON	On
		When the LDP system is OFF	Off
Shift position	<ul style="list-style-type: none"> • Engine running • While driving 		Displays the shift position
Turn signal	Turn signal lamps OFF		Off
	Turn signal lamp LH blinking		LH
	Turn signal lamp RH blinking		RH
	Turn signal lamp LH and RH blinking		LH&RH
SIDE G	While driving	Vehicle turning right	Negative value
		Vehicle turning left	Positive value
FUNC ITEM(FCW)	Ignition switch ON		FCW
FUNC ITEM(LDW)	Ignition switch ON		LDW
FUNC ITEM(BSW)	Ignition switch ON		BSW
FUNC ITEM (NV-ICC)	NOTE: The item is indicated, but not monitored		Off
FUNC ITEM (NV-DCA)	NOTE: The item is indicated, but not monitored		Off
DCA SELECT	Ignition switch ON	"Distance Control Assist" set with the navigation system is ON	On
		"Distance Control Assist" set with the navigation system is OFF	Off

ADAS CONTROL UNIT

< ECU DIAGNOSIS INFORMATION >

[ICC]

Monitor item	Condition	Value/Status	
LDP SELECT	Ignition switch ON	"Lane Departure Prevention" set with the navigation system is ON	On
		"Lane Departure Prevention" set with the navigation system is OFF	Off
BSI SELECT	Ignition switch ON	"Blind Spot Intervention" set with the navigation system is ON	On
		"Blind Spot Intervention" set with the navigation system is OFF	Off
DRIVE MODE STATS	Ignition switch ON	When the DMS switch is in normal position	Std
		When the DMS switch is in SNOW position	SNO
		When the DMS switch is in ECO position	ECO
		When the DMS switch is in SPORT position	SPT
WARN SYS SW	Ignition switch ON	When warning systems switch is pressed	On
		When warning systems switch is not pressed	Off
BSW/BSI WARN LMP	Ignition switch ON	Blind Spot Warning/Blind Spot Intervention warning lamp ON	On
		Blind Spot Warning/Blind Spot Intervention warning lamp OFF	Off
BSI ON IND	Ignition switch ON	Blind Spot Intervention ON indicator ON	On
		Blind Spot Intervention ON indicator OFF	Off
BSW SYSTEM ON	Ignition switch ON	When the BSW system is ON (Warning systems ON indicator ON)	On
		When the BSW system is OFF (Warning systems ON indicator OFF)	Off
BSI SYSTEM ON	Start the engine and press dynamic driver assistance switch (When Blind Spot Intervention system setting is ON)	When the Blind Spot Intervention system is ON	On
		When the Blind Spot Intervention system is OFF	Off
BCI SYSTEM ON	Ignition switch ON	Back-up Collision Intervention system ON	On
		Back-up Collision Intervention system OFF	Off
BCI SWITCH	Ignition switch ON	Back-up Collision Intervention switch ON	On
		Back-up Collision Intervention switch OFF	Off
LDP WARNING INDICATOR	Ignition switch ON	When the LDP fail lamp is ON (Warning systems ON indicator ON)	On
		When the LDP fail lamp is OFF	Off
LDW ON LAMP	Ignition switch ON	When LDW indicator lamp is ON	On
		When LDW indicator lamp is OFF	Off
LDW WARNING INDICATOR	Ignition switch ON	When LDW FAIL lamp is ON	On
		When LDW FAIL lamp is OFF	Off
SYSTEM CANCEL MESSAGE	Ignition switch ON	When a system cancel message is sent	Request
		When a system cancel message is not sent	No Request
CAMERA HI TEMP MSG	Ignition switch ON	When camera high temperature message is sent	On
		When camera high temperature message is not sent	Off
ITS Setting Item(DCA)	Ignition switch ON	When the DCA is set	On
		When the DCA is not set	Off
ITS Setting Item(LDP)	Ignition switch ON	When the LDP is set	On
		When the LDP is not set	Off

A
B
C
D
E
F
G
H
I
J
K
L
M
N
P

CCS

ADAS CONTROL UNIT

< ECU DIAGNOSIS INFORMATION >

[ICC]

Monitor item	Condition		Value/Status
ITS Setting Item(BSI)	Ignition switch ON	When the BSI is set	On
		When the BSI is not set	Off
BSI WARNING INDICATOR	Ignition switch ON	When BSI FAIL indicator warning lamp is ON	On
		When BSI FAIL indicator warning lamp is OFF	Off
BSW ON INDICATOR	Ignition switch ON	When BSW ON indicator lamp is ON	On
		When BSW ON indicator lamp is OFF	Off
BSW IND BRIGHTNESS	Ignition switch ON	When BSW indicator brightness is selected	On
		When BSW indicator brightness is not selected	Off
WARN REQ	Drive the vehicle and activate the LDP system	Lane departure warning is operating	On
		Lane departure warning is not operating	Off

TERMINAL LAYOUT
PHYSICAL VALUES

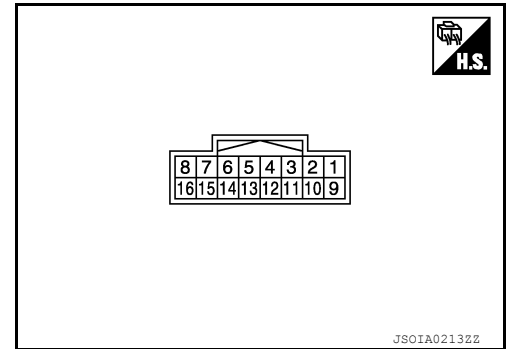

ADAS CONTROL UNIT

< ECU DIAGNOSIS INFORMATION >

[ICC]

Terminal No. (Wire color)		Description		Condition		Value (Approx.)
+	-	Signal name	Input/ Output			
1 (BR)		Warning systems switch	Input	Ignition switch ON	When warning systems switch is not pressed	12 V
					When warning systems switch is pressed	0 V
4 (W)		Warning systems On indicator	Output	Ignition switch ON	Warning systems ON indicator ON	0 V
					Warning systems ON indicator OFF	12 V
5 (G)		ICC brake hold relay drive signal	Output	Ignition switch ON	—	12 V
					At "STOP LAMP" test of "Active test"	0 V
6 (B)		Ground	Input	—	—	0 V
7 (L)	Ground	ITS communication-H	—	—	—	—
8 (Y)		ITS communication-L	—	—	—	—
10 (BG)		BCI OFF switch	Input	Ignition switch ON	When BCI OFF switch is not pressed	12 V
					When BCI OFF switch is pressed	0 V
12 (G)		Warning buzzer signal	Output	Ignition switch ON	Warning buzzer operation	0 V
					Warning buzzer not operating	12 V
14 (B)		CAN -H	—	—	—	—
15 (W)		CAN -L	—	—	—	—
16 (R)		Ignition power supply	Input	Ignition switch ON		Battery Voltage

Fail-safe

INFOID:000000011558204

If a malfunction occurs in each system, ADAS control unit cancels each control, sounds a beep, and turns ON the warning lamp or indicator lamp.

System	Buzzer	Warning lamp/Indicator lamp	Description
Vehicle-to-vehicle distance control mode	High-pitched tone	ICC system warning lamp	Cancel
Conventional (fixed speed) cruise control mode	High-pitched tone	ICC system warning lamp	Cancel
Intelligent Brake Assist (IBA)	High-pitched tone	IBA OFF indicator lamp	Cancel
Forward Collision Warning (FCW)	High-pitched tone	Warning message	Cancel
Distance Control Assist (DCA)	High-pitched tone	DCA system warning	Cancel
Lane Departure Warning (LDW)	—	Lane departure warning lamp	Cancel
Lane Departure Prevention (LDP)	Low-pitched tone	Lane departure warning lamp	Cancel

ADAS CONTROL UNIT

< ECU DIAGNOSIS INFORMATION >

[ICC]

System	Buzzer	Warning lamp/Indicator lamp	Description
Blind Spot Warning (BSW)	—	Blind Spot Warning/Blind Spot Intervention warning lamp	Cancel
Blind Spot Intervention	Low-pitched tone	Blind Spot Warning/Blind Spot Intervention warning lamp	Cancel
Backup Collision Intervention (BCI)	High-pitched tone	Backup Collision Intervention warning indicator	Cancel

DTC Inspection Priority Chart

INFOID:000000011558205

If multiple DTCs are detected simultaneously, check them one by one depending on the following DTC inspection priority chart.

Priority	Detected items (DTC)
1	<ul style="list-style-type: none"> • C1A0A: CONFIG UNFINISHED • U1507: LOST COMM (SIDE RDR R) • U1508: LOST COMM (SIDE RDR L)
2	<ul style="list-style-type: none"> • U1000: CAN COMM CIRCUIT • U1010: CONTROL UNIT (CAN)
3	<ul style="list-style-type: none"> • C1B00: CAMERA UNIT MALF • C1F02: APA C/U MALF • C1A17: ICC SENSOR MALF • C1B53: SIDE RDR R MALF • C1B54: SIDE RDR L MALF

ADAS CONTROL UNIT

< ECU DIAGNOSIS INFORMATION >

[ICC]

Priority	Detected items (DTC)		
4	<ul style="list-style-type: none"> • C1A01: POWER SUPPLY CIR • C1A02: POWER SUPPLY CIR 2 • C1A04: ABS/TCS/VDC CIRC • C1A05: BRAKE SW/STOP L SW • C1A06: OPERATION SW CIRC • C1A12: LASER BEAM OFFCNTR • C1A13: STOP LAMP RLY FIX • C1A14: ECM CIRCUIT • C1A16: RADAR STAIN • C1A18: LASER AIMING INCOMP • C1A2A: ICC SEN PWR SUP CIR • C1A21: ICC SENSOR HIGH TEMP • C1A24: NP RANGE • C1A26: ECD MODE MALF • C1A27: ECD PWR SUPPLY CIR • C1A33: CAN TRANSMISSION ERR • C1A34: COMMAND ERROR • C1A35: APA CIR • C1A36: APA CAN COMM CIR • C1A37: APA CAN CIR 2 • C1A38: APA CAN CIR 1 • C1A39: STRG SEN CIR • C1A40: SYSTEM SW CIRC • C1B01: CAM AIMING INCOMP • C1B03: CAM ABNRML TMP DETCT • C1B56: SONAR CIRCUIT • C1B57: AVM CIRCUIT • C1F01: APA MOTOR MALF • C1F05: APA PWR SUPPLY CIR • U0121: VDC CAN CIR 2 • U0126: STRG SEN CAN CIR 1 • U0235: ICC SENSOR CAN CIRC 1 • U0401: ECM CAN CIR 1 • U0402: TCM CAN CIR 1 • U0415: VDC CAN CIR 1 • U0428: STRG SEN CAN CIR 2 • U1500: CAM CAN CIR 2 • U1501: CAM CAN CIR 1 • U1502: ICC SEN CAN COMM CIR • U1503: SIDE RDR L CAN CIR 2 • U1504: SIDE RDR L CAN CIR 1 • U1505: SIDE RDR R CAN CIR 2 • U1506: SIDE RDR R CAN CIR 1 • U1521: SONAR CAN COMMUNICATION • U1522: SONAR CAN COMMUNICATION • U1523: SONAR CAN COMMUNICATION • U1524: AVM CAN COMMUNICATION • U1525: AVM CAN COMMUNICATION • U150B: ECM CAN CIRC 3 • U150C: VDC CAN CIRC 3 • U150D: TCM CAN CIRC 3 • U150E: BCM CAN CIRC 3 • U150F: AV CAN CIRC 3 • U1512: HVAC CAN CIRC3 • U1513: METER CAN CIRC 3 • U1514: STRG SEN CAN CIRC 3 • U1515: ICC SENSOR CAN CIRC 3 • U1516: CAM CAN CIRC 3 • U1517: APA CAN CIRC 3 • U1518: SIDE RDR L CAN CIRC 3 • U1519: SIDE RDR R CAN CIRC 3 	<p>A</p> <p>B</p> <p>C</p> <p>D</p> <p>E</p> <p>F</p> <p>G</p> <p>H</p> <p>I</p> <p>J</p> <p>K</p> <p>L</p> <p>M</p> <p>N</p> <p>P</p>	
	5	<ul style="list-style-type: none"> • C1A03: VHCL SPEED SE CIRC 	
	6	<ul style="list-style-type: none"> • C1A15: GEAR POSITION 	
	7	<ul style="list-style-type: none"> • C1A00: CONTROL UNIT 	

CCS

ADAS CONTROL UNIT

< ECU DIAGNOSIS INFORMATION >

[ICC]

DTC Index

INFOID:000000011558206

NOTE:

- The details of time display are as per the following.
- CRNT: A malfunction is detected now
- PAST: A malfunction was detected in the past
- IGN counter is displayed on FFD (Freeze Frame Data).
- 0: The malfunctions that are detected now
CAN communication system (U1000, U1010)
- 1 - 39: It increases like 0 → 1 → 2 ... 38 → 39 after returning to the normal condition whenever the ignition switch OFF → ON. It returns to 0 when a malfunction is detected again in the process.
- If it is over 39, it is fixed to 39 until the self-diagnosis results are erased.
Other than CAN communication system (Other than U1000, U1010)
- 1 - 49: It increases like 0 → 1 → 2 ... 38 → 49 after returning to the normal condition whenever the ignition switch OFF → ON. It returns to 0 when a malfunction is detected again in the process.
- If it is over 49, it is fixed to 49 until the self-diagnosis results are erased.

Systems for fail-safe

- A: Vehicle-to-vehicle distance control mode
- B: Conventional (fixed speed) cruise control mode
- C: Intelligent Brake Assist (IBA)
- D: Forward Collision Warning (FCW)
- E: Distance Control Assist (DCA)
- F: Lane Departure Warning (LDW)/Lane Departure Prevention (LDP)
- G: Blind Spot Warning (BSW)/Blind Spot Intervention
- H: Backup Collision Intervention (BCI)

DTC		CONSULT display	Warning lamp					Fail-safe	Reference
CONSULT	On board display		ICC system warning lamp	IBA OFF indicator lamp	Lane departure warning lamp	Blind Spot Warning/Blind Spot Intervention warning lamp	Backup Collision Intervention	System	
C1A0A	10	CONFIG UNFIISHED	ON	ON	ON	ON	ON	A, B, C, D, E, F, G, H	DAS-78
C1A00	0	CONTROL UNIT	ON	ON	ON	ON	ON	A, B, C, D, E, F, G, H	DAS-79
C1A01	1	POWER SUPPLY CIR	ON	ON	ON	ON	ON	A, B, C, D, E, F, G, H	DAS-80
C1A02	2	POWER SUPPLY CIR 2	ON	ON	ON	ON	ON	A, B, C, D, E, F, G, H	DAS-80
C1A03	3	VHCL SPEED SE CIRC	ON	ON	ON	ON	ON	A, B, C, D, E, F, G, H	DAS-168
C1A04	4	ABS/TCS/VDC CIRC	ON	ON	ON	ON	ON	A, B, C, D, E, F, G, H	DAS-170
C1A05	5	BRAKE SW/STOP L SW	ON	ON	ON	ON	ON	A, B, C, D, E, F, G, H	DAS-171
C1A06	6	OPERATION SW CIRC	ON		ON	ON		A, B, E, F, G	DAS-176
C1A12	12	LASER BEAM OFFCN-TR	ON	ON				A, C, D, E	DAS-179
C1A13	13	STOP LAMP RLY FIX	ON	ON			ON	A, B, C, D, E, H	DAS-180

ADAS CONTROL UNIT

< ECU DIAGNOSIS INFORMATION >

[ICC]

Systems for fail-safe

- A: Vehicle-to-vehicle distance control mode
- B: Conventional (fixed speed) cruise control mode
- C: Intelligent Brake Assist (IBA)
- D: Forward Collision Warning (FCW)
- E: Distance Control Assist (DCA)
- F: Lane Departure Warning (LDW)/Lane Departure Prevention (LDP)
- G: Blind Spot Warning (BSW)/Blind Spot Intervention
- H: Backup Collision Intervention (BCI)

DTC		CONSULT display	Warning lamp					Fail-safe	Reference
CONSULT	On board display		ICC system warning lamp	IBA OFF indicator lamp	Lane departure warning lamp	Blind Spot Warning/Blind Spot Intervention warning lamp	Backup Collision Intervention	System	
C1A14	14	ECM CIRCUIT	ON		ON	ON	ON	A, B, E, F, G, H	DAS-186
C1A15	15	GEAR POSITION	ON	ON	ON	ON	ON	A, B, C, D, E, F, G, H	DAS-187
C1A16	16	RADAR STAIN	ON	ON				A, C, D, E	DAS-189
C1A17	17	ICC SENSOR MALF	ON	ON				A, B, C, D, E	DAS-191
C1A18	18	LASER AIMING INCOMP	ON	ON				A, C, D, E	DAS-192
C1A21	21	ICC SENSOR HIGH TEMP	ON	ON				A, B, C, D, E	DAS-193
C1A24	24	NP RANGE	ON	ON	ON	ON	ON	A, B, C, D, E, F, G, H	DAS-194
C1A26	26	ECD MODE MALF	ON	ON				A, B, C, D, E	DAS-196
C1A27	27	ECD PWR SUPPLY CIR	ON	ON				A, B, C, D, E	DAS-197
C1A33	33	CAN TRANSMISSION ERR	ON					A, B, E	DAS-199
C1A34	34	COMMAND ERROR	ON					A, B, E	DAS-200
C1A35	35	APA CIR	ON				ON	A, E, H	DAS-201
C1A36	36	APA CAN COMM CIR	ON				ON	A, E, H	DAS-202
C1A37	133	APA CAN CIR 2	ON				ON	A, B, E, H	DAS-203
C1A38	132	APA CAN CIR 1	ON				ON	A, B, E, H	DAS-204
C1A39	39	STRG SEN CIR	ON	ON		ON	ON	A, B, C, D, E, G, H	DAS-205
C1A2A	80	ICC SEN PWR SUP CIR	ON	ON				A, C, D, E	CCS-139
C1B00	81	CAMERA UNIT MALF			ON	ON		F, G	DAS-586
C1B01	82	CAM AIMING INCOMP			ON	ON		F, G	DAS-588
C1B03	83	CAM ABRML TMP DETECT							DAS-590
C1B53	84	SIDE RDR R MALF				ON	ON	G, H	DAS-595
C1B54	85	SIDE RDR L MALF				ON	ON	G, H	DAS-596

A
B
C
D
E
F
G
H
I
J
K
L
M
N
P

CCS

ADAS CONTROL UNIT

< ECU DIAGNOSIS INFORMATION >

[ICC]

Systems for fail-safe

- A: Vehicle-to-vehicle distance control mode
- B: Conventional (fixed speed) cruise control mode
- C: Intelligent Brake Assist (IBA)
- D: Forward Collision Warning (FCW)
- E: Distance Control Assist (DCA)
- F: Lane Departure Warning (LDW)/Lane Departure Prevention (LDP)
- G: Blind Spot Warning (BSW)/Blind Spot Intervention
- H: Backup Collision Intervention (BCI)

DTC		CONSULT display	Warning lamp					Fail-safe	Reference
CONSULT	On board display		ICC system warning lamp	IBA OFF indicator lamp	Lane departure warning lamp	Blind Spot Warning/Blind Spot Intervention warning lamp	Backup Collision Intervention	System	
C1B56	87	SONAR CIRCUIT					ON	H	DAS-765
C1B57	88	AVM CIRCUIT					ON	H	DAS-766
C1F01	91	APA MOTOR MALF	ON				ON	A, E, H	DAS-206
C1F02	92	APA C/U MALF	ON				ON	A, E, H	DAS-208
C1F05	95	APA PWR SUPPLY CIR	ON				ON	A, E, H	DAS-211
NO DTC IS DETECTED. FURTHER TESTING MAY BE REQUIRED	55	NO DTC IS DETECTED. FURTHER TESTING MAY BE REQUIRED	—	—	—	—	—	—	—
U0121	127	VDC CAN CIR 2	ON	ON	ON	ON	ON	A, B, C, D, E, F, G, H	DAS-215
U0126	130	STRG SEN CAN CIR 1	ON	ON		ON	ON	A, B, C, D, E, G, H	DAS-216
U0235	144	ICC SENSOR CAN CIRC 1	ON	ON				A, B, C, D, E	DAS-217
U0401	120	ECM CAN CIR 1	ON		ON	ON	ON	A, B, E, F, G, H	DAS-218
U0402	122	TCM CAN CIR 1	ON	ON	ON	ON	ON	A, B, C, D, E, F, G, H	DAS-219
U0415	126	VDC CAN CIR 1	ON	ON	ON	ON	ON	A, B, C, D, E, F, G, H	DAS-220
U0428	131	STRG SEN CAN CIR 2	ON	ON		ON	ON	A, B, C, D, E, G, H	DAS-221
U1000 ^{NOTE}	100	CAN COMM CIRCUIT	ON	ON	ON	ON	ON	A, B, C, D, E, F, G, H	DAS-81
U1010	110	CONTROL UNIT (CAN)	ON	ON	ON	ON	ON	A, B, C, D, E, F, G, H	DAS-82
U1500	145	CAM CAN CIR 2			ON	ON		F, G	DAS-453
U1501	146	CAM CAN CIR 1			ON	ON		F, G	DAS-454
U1502	147	ICC SEN CAN COMM CIR	ON	ON				A, B, C, D, E	DAS-229

ADAS CONTROL UNIT

< ECU DIAGNOSIS INFORMATION >

[ICC]

Systems for fail-safe

- A: Vehicle-to-vehicle distance control mode
- B: Conventional (fixed speed) cruise control mode
- C: Intelligent Brake Assist (IBA)
- D: Forward Collision Warning (FCW)
- E: Distance Control Assist (DCA)
- F: Lane Departure Warning (LDW)/Lane Departure Prevention (LDP)
- G: Blind Spot Warning (BSW)/Blind Spot Intervention
- H: Backup Collision Intervention (BCI)

DTC		CONSULT display	Warning lamp					Fail-safe	Reference
CONSULT	On board display		ICC system warning lamp	IBA OFF indicator lamp	Lane departure warning lamp	Blind Spot Warning/Blind Spot Intervention warning lamp	Backup Collision Intervention	System	
U1503	150	SIDE RDR L CAN CIR 2				ON	ON	G, H	DAS-621
U1504	151	SIDE RDR L CAN CIR 1				ON	ON	G, H	DAS-622
U1505	152	SIDE RDR R CAN CIR 2				ON	ON	G, H	DAS-623
U1506	153	SIDE RDR R CAN CIR 1				ON	ON	G, H	DAS-624
U1507	154	LOST COMM (SIDE RDR R)				ON	ON	G, H	DAS-625
U1508	155	LOST COMM (SIDE RDR L)				ON	ON	G, H	DAS-626
U150B	157	ECM CAN CIRC 3	ON		ON	ON	ON	A, B, E, F, G, H	DAS-225
U150C	158	VDC CAN CIRC 3	ON	ON	ON	ON	ON	A, B, C, D, E, F, G, H	DAS-226
U150D	159	TCM CAN CIRC 3	ON	ON	ON	ON	ON	A, B, C, D, E, F, G, H	DAS-227
U150E	160	BCM CAN CIRC 3	ON		ON	ON	ON	A, B, E, F, G, H	DAS-228
U150F	161	AV CAN CIRC 3							DAS-83
U1512	162	HVAC CAN CIRC3			ON	ON		F, G	DAS-455
U1513	163	METER CAN CIRC 3	ON	ON	ON	ON	ON	A, B, C, D, E, F, G, H	DAS-230
U1514	164	STRG SEN CAN CIRC 3	ON	ON		ON	ON	A, B, C, D, E, G, H	DAS-231
U1515	165	ICC SENSOR CAN CIRC 3	ON	ON				A, B, C, D, E	DAS-232
U1516	166	CAM CAN CIRC 3			ON	ON		F, G	DAS-457
U1517	167	APA CAN CIRC 3	ON				ON	A, B, E, H	DAS-233
U1518	168	SIDE RDR L CAN CIRC 3				ON	ON	G, H	DAS-631
U1519	169	SIDE RDR R CAN CIRC 3				ON	ON	G, H	DAS-632
U1521	177	SONAR CHECKSUM					ON	H	DAS-802
U1522	178	SONAR MESSAGE					ON	H	DAS-803

A
B
C
D
E
F
G
H
I
J
K
L
M
N
P

CCS

ADAS CONTROL UNIT

< ECU DIAGNOSIS INFORMATION >

[ICC]

Systems for fail-safe

- A: Vehicle-to-vehicle distance control mode
- B: Conventional (fixed speed) cruise control mode
- C: Intelligent Brake Assist (IBA)
- D: Forward Collision Warning (FCW)
- E: Distance Control Assist (DCA)
- F: Lane Departure Warning (LDW)/Lane Departure Prevention (LDP)
- G: Blind Spot Warning (BSW)/Blind Spot Intervention
- H: Backup Collision Intervention (BCI)

DTC		CONSULT display	Warning lamp					Fail-safe	Reference
CONSULT	On board display		ICC system warning lamp	IBA OFF indicator lamp	Lane departure warning lamp	Blind Spot Warning/Blind Spot Intervention warning lamp	Backup Collision Intervention	System	
U1523	179	SONAR CAN DLC					ON	H	DAS-804
U1524	180	SONAR CAN DLC					ON	H	DAS-805
U1525	181	AVM MESSAGE					ON	H	DAS-806

NOTE:

With the detection of “U1000” some systems do not perform the fail-safe operation.

A system controlling based on a signal received from the control unit performs fail-safe operation when the communication with the ADAS control unit becomes inoperable.

ICC SENSOR

< ECU DIAGNOSIS INFORMATION >

[ICC]

ICC SENSOR

Reference Value

INFOID:000000011132064

VALUES ON THE DIAGNOSIS TOOL

Monitor item	Condition		Value/Status
VHCL SPEED SE	While driving		Value of vehicle speed signal (wheel speed)
YAW RATE	While driving	Vehicle stopped	0.0
		Vehicle turning right	Positive value
		Vehicle turning left	Negative value
PWR SUP MONI	Ignition switch ON		Power supply voltage value of ICC sensor
DISTANCE	Drive the vehicle and activate the vehicle-to-vehicle distance control mode	When a vehicle ahead is detected	Displays the distance from the preceding vehicle
		When a vehicle ahead is not detected	0.0
RELATIVE SPD	Drive the vehicle and activate the vehicle-to-vehicle distance control mode	When a vehicle ahead is detected	Displays the relative speed
		When a vehicle ahead is not detected	0.0
RADAR OFFSET	NOTE: The item is indicated, but not used		—
RADAR HEIGHT	NOTE: The item is indicated, but not used		—
STEERING ANGLE	Ignition switch ON	When setting the steering wheel in straight-ahead position	0.0
		When turning the steering wheel 90° rightward	+90
		When turning the steering wheel 90° leftward	-90
STRG ANGLE SPEED	Ignition switch ON	At the time of turning the steering wheel	Steering wheel turning speed is displayed
L/R ADJUST	Ignition switch ON	At the completion of radar alignment adjustment	Horizontal correction value is displayed
U/D ADJUST	Ignition switch ON	At the completion of radar alignment adjustment	Vertical correction value is displayed

TERMINAL LAYOUT

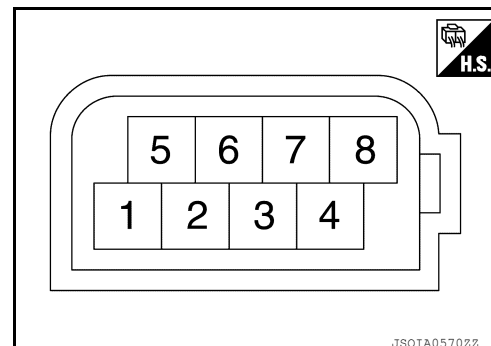

PHYSICAL VALUES

A

B

C

D

E

F

G

H

I

J

K

L

M

N

CCS

P

ICC SENSOR

< ECU DIAGNOSIS INFORMATION >

[ICC]

Terminal No. (Wire color)		Description		Condition	Standard value	Reference value (Approx.)
+	-	Signal name	Input/ Output			
1 (P)	8 (B)	Ignition power supply	Input	Ignition switch ON	9.5 - 16 V	Battery voltage
6 (Y)	—	ITS communication-L	—	—	—	—
7 (L)		ITS communication-H	—	—	—	—
8 (B)	Ground	Ground	—	Ignition switch ON	0 - 0.1 V	0 V

Fail-safe

INFOID:0000000011132065

If a malfunction occurs in the ICC sensor, ADAS control unit cancels control, sounds a beep, and turns ON the ICC system warning lamp in the combination meter.

DTC Inspection Priority Chart

INFOID:0000000011132066

If multiple DTCs are detected simultaneously, check them one by one depending on the following DTC inspection priority chart.

Priority	Detected items (DTC)
1	<ul style="list-style-type: none"> U1000: CAN COMM CIRCUIT U1010: CONTROL UNIT (CAN)
2	<ul style="list-style-type: none"> C1A50: ADAS MALFUNCTION
3	<ul style="list-style-type: none"> C1A01: POWER SUPPLY CIR C1A02: POWER SUPPLY CIR 2 C1A12 :RADAR OFF-CENTER C1A16: RADAR BLOCKED C1A18: RADAR ALIGNMENT INCOMPLETE C1A21: UNIT HIGH TEMP C1A39: STRG SEN CIR C10B7: YAW RATE SENSOR U0104: ADAS CAN CIR1 U0121: VDC CAN CIR2 U0126: STRG SEN CAN CIR1 U0405: ADAS CAN CIR2 U0415: VDC CAN CIR1 U0428: STRG SEN CAN CIR2
4	<ul style="list-style-type: none"> C1A00: CONTROL UNIT

DTC Index

INFOID:0000000011132067

NOTE:

- The details of time display are as per the following.
- 0: The malfunctions that are detected now
CAN communication system (U1000, U1010)
- 1 - 39: It increases like 0 → 1 → 2 ... 38 → 39 after returning to the normal condition whenever the ignition switch OFF → ON. It returns to 0 when a malfunction is detected again in the process.
- If it is over 39, it is fixed to 39 until the self-diagnosis results are erased.
Other than CAN communication system (Other than U1000, U1010)
- 1 - 49: It increases like 0 → 1 → 2 ... 38 → 49 after returning to the normal condition whenever the ignition switch OFF → ON. It returns to 0 when a malfunction is detected again in the process.
- If it is over 49, it is fixed to 49 until the self-diagnosis results are erased.

ICC SENSOR

< ECU DIAGNOSIS INFORMATION >

[ICC]

×: Applicable

DTC	CONSULT display	ICC system warning lamp	Fail-safe function						Reference
			Vehicle-to-vehicle distance control mode	Conventional (fixed speed) cruise control mode	Distance Control Assist (DCA)	Forward Collision Warning (FCW)	Intelligent Brake Assist (IBA)	Brake Assist (with preview function)	
C1A00	CONTROL UNIT	ON	×	×	×	×	×	×	CCS-103
C1A01	POWER SUPPLY CIR	ON	×	×	×	×	×	×	CCS-105
C1A02	POWER SUPPLY CIR2	ON	×	×	×	×	×	×	CCS-105
C1A12	RADAR OFF-CENTER	ON	×		×	×	×	×	CCS-118
C1A16	RADAR STAIN	ON	×		×	×	×	×	CCS-128
C1A18	RADAR ALIGNMENT INCOMPLETE	ON	×		×	×	×	×	CCS-132
C1A21	UNIT HIGH TEMP	ON	×	×	×	×	×	×	CCS-133
C1A39	STRG SEN CIR	ON	×	×	×	×	×	×	CCS-146
C1A50	ADAS MALFUNCTION	ON	×	×	×	×	×	×	CCS-147
C10B7	YAW RATE SENSOR	ON	×	×	×	×	×	×	CCS-151
U0104	ADAS CAN CIR1	ON	×	×	×	×	×	×	CCS-152
U0121	VDC CAN CIR2	ON	×	×	×	×	×	×	CCS-153
U0126	STRG SEN CAN CIR1	ON	×	×	×	×	×	×	CCS-155
U0405	ADAS CAN CIR2	ON	×	×	×	×	×	×	CCS-160
U0415	VDC CAN CIR1	ON	×	×	×	×	×	×	CCS-161
U0428	STRG SEN CAN CIR2	ON	×	×	×	×	×	×	CCS-163
U1000	CAN COMM CIRCUIT	ON	×	×	×	×	×	×	CCS-165
U1010	CONTROL UNIT (CAN)	ON	×	×	×	×	×	×	CCS-167

A
B
C
D
E
F
G
H
I
J
K
L
M
N
P

CCS

INTELLIGENT CRUISE CONTROL

[ICC]

< WIRING DIAGRAM >

WIRING DIAGRAM

INTELLIGENT CRUISE CONTROL

Wiring Diagram

INFOID:000000011132068

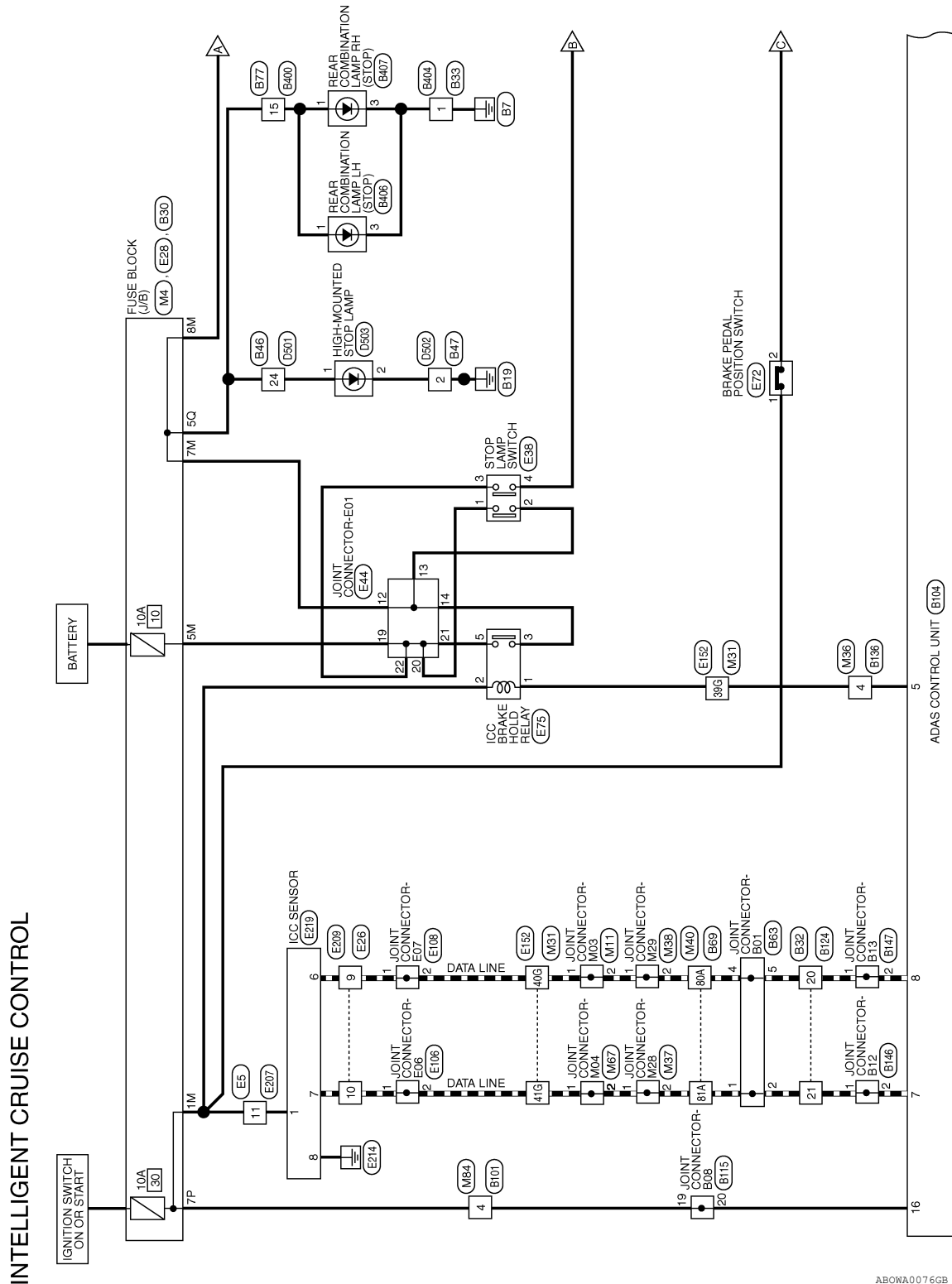

ABOWA0076GB

INTELLIGENT CRUISE CONTROL

[ICC]

< WIRING DIAGRAM >

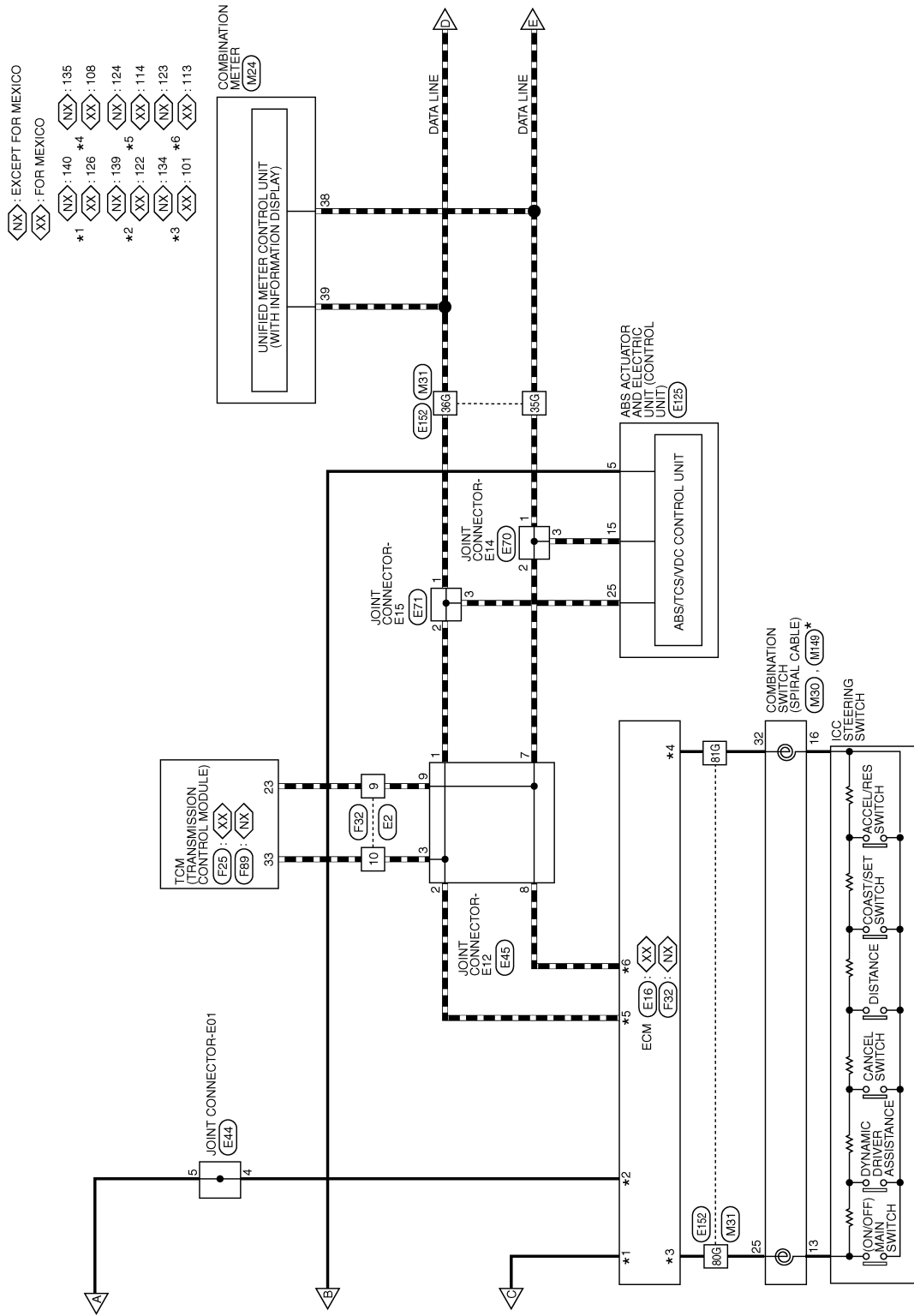

*: THIS CONNECTOR IS NOT SHOWN IN "HARNES LAYOUT" OF PG SECTION.

ABOWA0077GB

A
B
C
D
E
F
G
H
I
J
K
L
M
N
P

CCS

INTELLIGENT CRUISE CONTROL

< WIRING DIAGRAM >

[ICC]

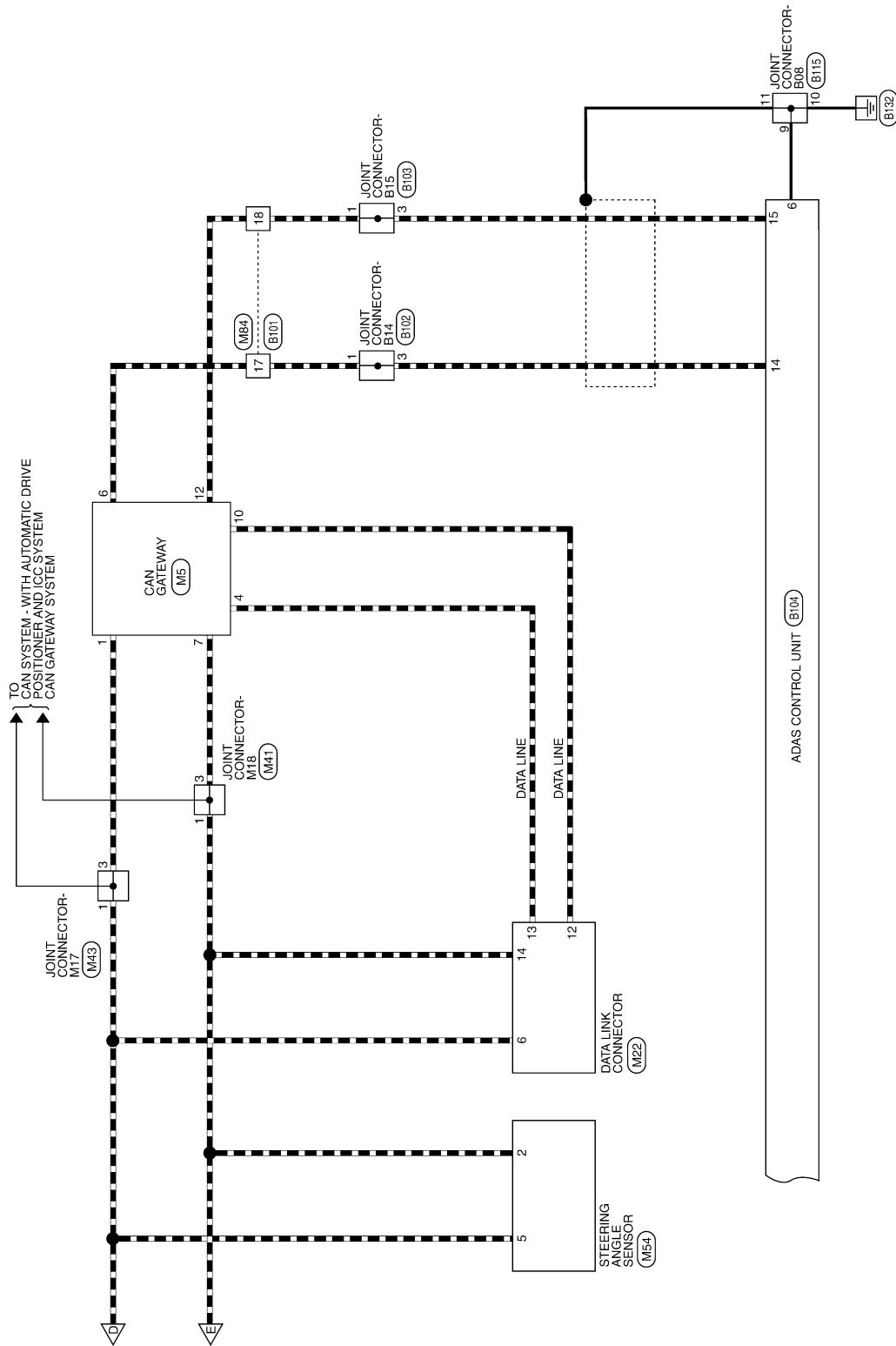

ABOWA0029GB

INTELLIGENT CRUISE CONTROL CONNECTORS

Connector No.	M11
Connector Name	JOINT CONNECTOR-M03
Connector Color	WHITE



Terminal No.	Color of Wire	Signal Name
1	Y	-
2	Y	-

Connector No.	M5
Connector Name	CAN GATEWAY
Connector Color	WHITE

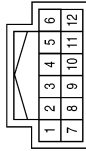

Terminal No.	Color of Wire	Signal Name
1	L	CAN-H
4	L	CAN-H
6	L	CAN-H
7	P	CAN-L
10	P	CAN-L
12	P	CAN-L

Connector No.	M4
Connector Name	FUSE BLOCK (J/B)
Connector Color	WHITE



Terminal No.	Color of Wire	Signal Name
7P	LG	-

Connector No.	M30
Connector Name	COMBINATION SWITCH (SPIRAL CABLE)
Connector Color	GRAY

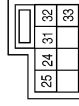

Terminal No.	Color of Wire	Signal Name
25	W	-
32	G	-

Connector No.	M24
Connector Name	COMBINATION METER
Connector Color	WHITE

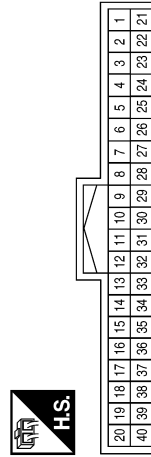

Terminal No.	Color of Wire	Signal Name
38	P	CAN-L
39	L	CAN-H

Connector No.	M22
Connector Name	DATA LINK CONNECTOR
Connector Color	WHITE

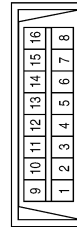

Terminal No.	Color of Wire	Signal Name
6	L	-
12	P	-
13	L	-
14	P	-

ABOIA0031GB

A B C D E F G H I J K L M N P



INTELLIGENT CRUISE CONTROL

< WIRING DIAGRAM >

[ICC]

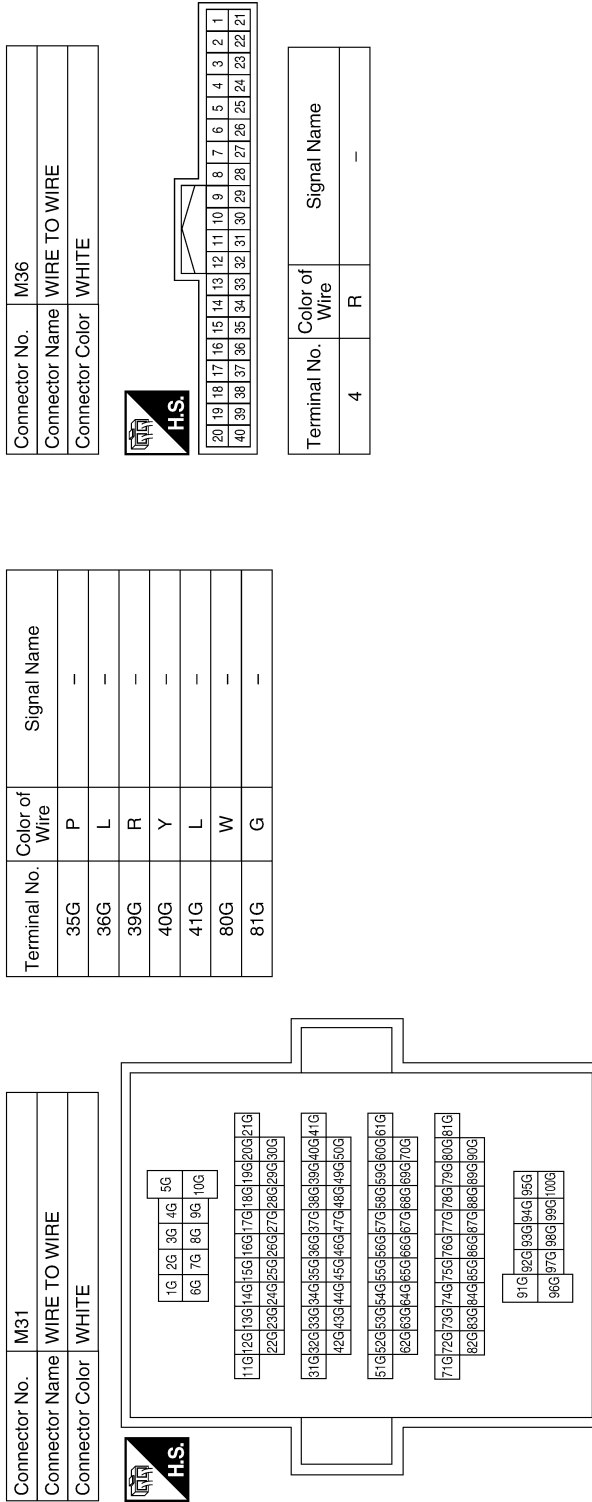

Connector No.	M36
Connector Name	WIRE TO WIRE
Connector Color	WHITE



20	19	18	17	16	15	14	13	12	11	10	9	8	7	6	5	4	3	2	1
40	39	38	37	36	35	34	33	32	31	30	29	28	27	26	25	24	23	22	21

Terminal No.	Color of Wire	Signal Name
4	R	-

Connector No.	M38
Connector Name	JOINT CONNECTOR-M29
Connector Color	WHITE



Terminal No.	Color of Wire	Signal Name
1	Y	-
2	Y	-

Connector No.	M37
Connector Name	JOINT CONNECTOR-M28
Connector Color	WHITE



Terminal No.	Color of Wire	Signal Name
1	L	-
2	L	-

ABOIA0032GB

INTELLIGENT CRUISE CONTROL

< WIRING DIAGRAM >

[ICC]

Connector No.	M41
Connector Name	JOINT CONNECTOR-M18
Connector Color	WHITE



Terminal No.	Color of Wire	Signal Name
1	P	-
3	P	-

Terminal No.	Color of Wire	Signal Name
80A	Y	-
81A	L	-

Connector No.	M40
Connector Name	WIRE TO WIRE
Connector Color	GRAY

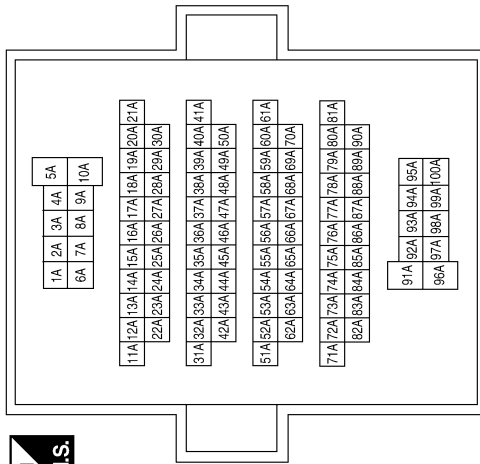

Connector No.	M67
Connector Name	JOINT CONNECTOR-M04
Connector Color	WHITE

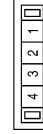

Terminal No.	Color of Wire	Signal Name
1	L	-
2	L	-

Connector No.	M54
Connector Name	STEERING ANGLE SENSOR
Connector Color	WHITE

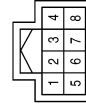

Terminal No.	Color of Wire	Signal Name
2	P	-
5	L	-

Connector No.	M43
Connector Name	JOINT CONNECTOR-M17
Connector Color	WHITE



Terminal No.	Color of Wire	Signal Name
1	L	-
3	L	-

ABOIA0088GB

A
B
C
D
E
F
G
H
I
J
K
L
M
N
P



INTELLIGENT CRUISE CONTROL

< WIRING DIAGRAM >

[ICC]

Connector No.	E2
Connector Name	WIRE TO WIRE
Connector Color	WHITE

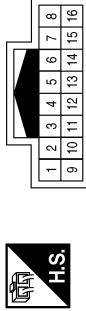

Terminal No.	Color of Wire	Signal Name
9	P	-
10	L	-

Connector No.	M149
Connector Name	COMBINATION SWITCH (SPIRAL CABLE)
Connector Color	GRAY

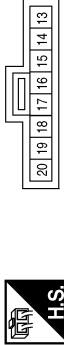

Terminal No.	Color of Wire	Signal Name
13	R	-
16	L	-

Connector No.	M84
Connector Name	WIRE TO WIRE
Connector Color	WHITE

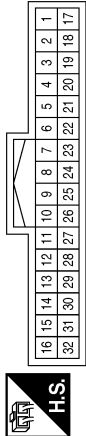

Terminal No.	Color of Wire	Signal Name
4	LG	-
17	L	-
18	P	-

Connector No.	E26
Connector Name	WIRE TO WIRE
Connector Color	WHITE

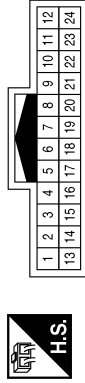

Terminal No.	Color of Wire	Signal Name
9	Y	-
10	BG	-

Connector No.	E16
Connector Name	ECM (FOR MEXICO)
Connector Color	GRAY

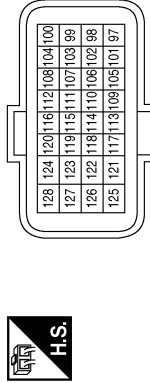

Terminal No.	Color of Wire	Signal Name
101	G	ASCD STEERING SWITCH/ICC STEERING SWITCH
108	R	SENSOR GROUND (ASCD STEERING SWITCH)
113	P	CAN-L
114	L	CAN-H
122	R	STOP LAMP SWITCH
126	LG	BRAKE PEDAL POSITION SWITCH

Connector No.	E5
Connector Name	WIRE TO WIRE
Connector Color	WHITE



Terminal No.	Color of Wire	Signal Name
11	R	-

A01A0246GB

INTELLIGENT CRUISE CONTROL

< WIRING DIAGRAM >

[ICC]

Connector No.	E28
Connector Name	FUSE BLOCK (J/B)
Connector Color	WHITE



Terminal No.	Color of Wire	Signal Name
1M	R	-
5M	Y	-
7M	P	-
8M	R	-

Connector No.	E32
Connector Name	ECM (EXCEPT FOR MEXICO)
Connector Color	BLACK

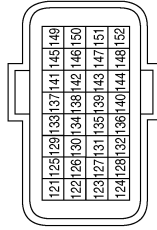

Terminal No.	Color of Wire	Signal Name
123	P	CAN-L
124	L	CAN-H
134	G	ASC/D STEERING SWITCH/ICC STEERING SWITCH
135	R	SENSOR GROUND
139	R	STOP LAMP SWITCH
140	LG	BRAKE PEDAL POSITION SWITCH

Connector No.	E38
Connector Name	STOP LAMP SWITCH
Connector Color	WHITE



Terminal No.	Color of Wire	Signal Name
1	Y	-
2	P	-
3	Y	-
4	G	-

Connector No.	E44
Connector Name	JOINT CONNECTOR-E01
Connector Color	WHITE

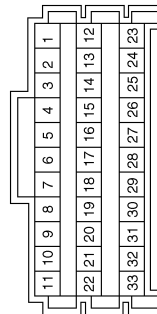

Terminal No.	Color of Wire	Signal Name
4	R	-
5	R	-
12	P	-
13	P	-

Terminal No.	Color of Wire	Signal Name
14	P	-
19	Y	-
20	Y	-
21	Y	-
22	Y	-

Connector No.	E45
Connector Name	JOINT CONNECTOR-E12
Connector Color	BLUE

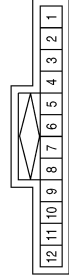

Terminal No.	Color of Wire	Signal Name
1	L	-
2	L	-
3	L	-
7	P	-
8	P	-
9	P	-

A
B
C
D
E
F
G
H
I
J
K
L
M
N
P



INTELLIGENT CRUISE CONTROL

< WIRING DIAGRAM >

[ICC]

Connector No.	E72
Connector Name	BRAKE PEDAL POSITION SWITCH (WITH INTELLIGENT CRUISE CONTROL)
Connector Color	BROWN



Terminal No.	Color of Wire	Signal Name
1	R	-
2	LG	-

Connector No.	E71
Connector Name	JOINT CONNECTOR-E15
Connector Color	BLACK

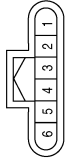

Terminal No.	Color of Wire	Signal Name
1	L	-
2	L	-
3	L	-

Connector No.	E70
Connector Name	JOINT CONNECTOR-E14
Connector Color	BLACK

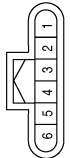

Terminal No.	Color of Wire	Signal Name
1	P	-
2	P	-
3	P	-

Connector No.	E108
Connector Name	JOINT CONNECTOR-E07
Connector Color	WHITE



Terminal No.	Color of Wire	Signal Name
1	Y	-
2	Y	-

Connector No.	E106
Connector Name	JOINT CONNECTOR-E06
Connector Color	WHITE



Terminal No.	Color of Wire	Signal Name
1	BG	-
2	BG	-

Connector No.	E75
Connector Name	ICC BRAKE HOLD RELAY
Connector Color	BLUE



Terminal No.	Color of Wire	Signal Name
1	W	-
2	R	-
3	P	-
5	Y	-

A01A0248GB

INTELLIGENT CRUISE CONTROL

< WIRING DIAGRAM >

[ICC]

Terminal No.	Color of Wire	Signal Name
35G	P	-
36G	L	-
39G	W	-
40G	Y	-
41G	BG	-
80G	G	-
81G	R	-

Connector No.	E152
Connector Name	WIRE TO WIRE
Connector Color	WHITE

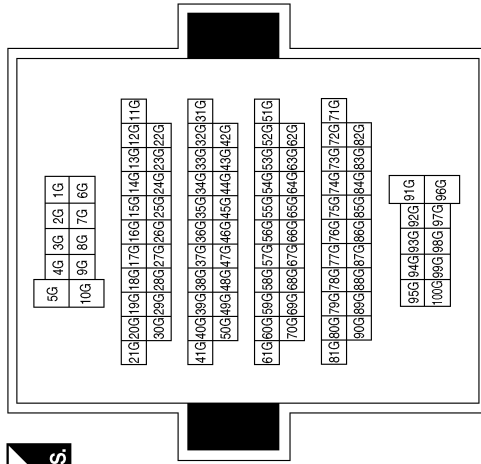

Connector No.	E125
Connector Name	ABS ACTUATOR AND ELECTRIC UNIT (CONTROL UNIT)
Connector Color	BLACK

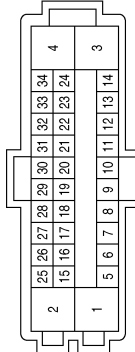

Terminal No.	Color of Wire	Signal Name
5	G	STOP LAMP SWITCH (WITH ICC)
15	P	CAN-L
25	L	CAN-H

Connector No.	E219
Connector Name	ICC SENSOR
Connector Color	BLACK

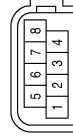

Connector No.	E209
Connector Name	WIRE TO WIRE
Connector Color	WHITE



Connector No.	E207
Connector Name	WIRE TO WIRE
Connector Color	WHITE

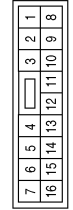

Terminal No.	Color of Wire	Signal Name
1	P	-
6	Y	-
7	L	-
8	B	-

Terminal No.	Color of Wire	Signal Name
9	Y	-
10	L	-

Terminal No.	Color of Wire	Signal Name
11	P	-

ABOIA0249GB

A
B
C
D
E
F
G
H
I
J
K
L
M
N
P



INTELLIGENT CRUISE CONTROL

< WIRING DIAGRAM >

[ICC]

Connector No.	F89
Connector Name	TCM (TRANSMISSION CONTROL MODULE) (EXCEPT FOR MEXICO)
Connector Color	BLACK

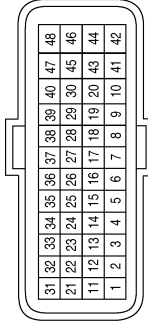

Terminal No.	Color of Wire	Signal Name
23	P	CAN-L
33	L	CAN-H

Connector No.	F32
Connector Name	WIRE TO WIRE
Connector Color	WHITE

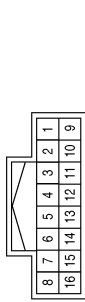

Terminal No.	Color of Wire	Signal Name
9	P	-
10	L	-

Connector No.	F25
Connector Name	TCM (TRANSMISSION CONTROL MODULE) (FOR MEXICO)
Connector Color	BLACK

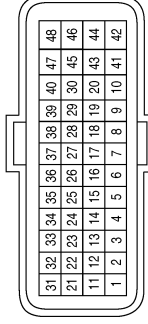

Terminal No.	Color of Wire	Signal Name
23	P	CAN-L
33	L	CAN-H

Connector No.	B33
Connector Name	WIRE TO WIRE
Connector Color	BLACK



Terminal No.	Color of Wire	Signal Name
1	B	-

Connector No.	B32
Connector Name	WIRE TO WIRE
Connector Color	WHITE

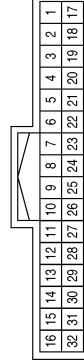

Terminal No.	Color of Wire	Signal Name
20	Y	-
21	L	-

Connector No.	B30
Connector Name	FUSE BLOCK (J/B)
Connector Color	WHITE



Terminal No.	Color of Wire	Signal Name
5Q	G	-

AB0IA0250GB

INTELLIGENT CRUISE CONTROL

< WIRING DIAGRAM >

[ICC]

Connector No.	B63
Connector Name	JOINT CONNECTOR-B01
Connector Color	WHITE

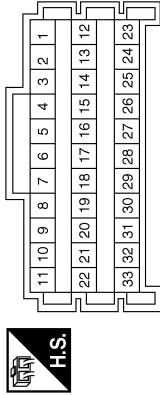

Terminal No.	Color of Wire	Signal Name
1	L	-
2	L	-
4	Y	-
5	Y	-

Connector No.	B47
Connector Name	WIRE TO WIRE
Connector Color	GRAY



Terminal No.	Color of Wire	Signal Name
2	B	-

Connector No.	B46
Connector Name	WIRE TO WIRE
Connector Color	WHITE

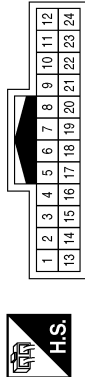

Terminal No.	Color of Wire	Signal Name
24	G	-

Connector No.	B77
Connector Name	WIRE TO WIRE
Connector Color	WHITE

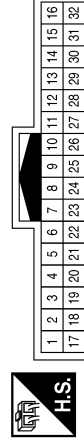

Terminal No.	Color of Wire	Signal Name
15	G	-

Terminal No.	Color of Wire	Signal Name
80A	Y	-
81A	L	-

Connector No.	B69
Connector Name	WIRE TO WIRE
Connector Color	GRAY

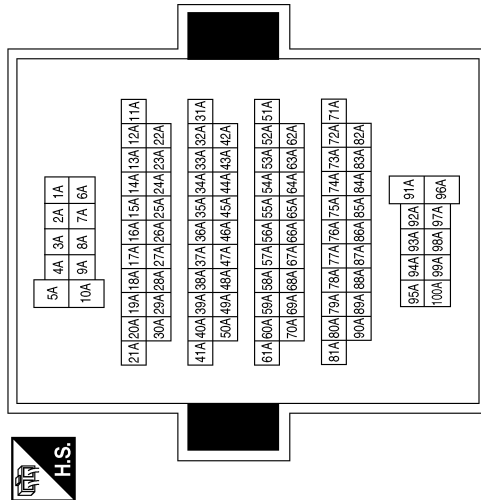

ABOIA0251GB

A
B
C
D
E
F
G
H
I
J
K
L
M
N
P



INTELLIGENT CRUISE CONTROL

< WIRING DIAGRAM >

[ICC]

Connector No.	B101
Connector Name	WIRE TO WIRE
Connector Color	WHITE

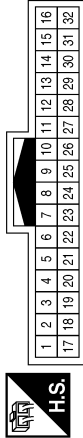

Terminal No.	Color of Wire	Signal Name
4	R	-
17	L	-
18	P	-

Connector No.	B102
Connector Name	JOINT CONNECTOR-B14
Connector Color	WHITE



Terminal No.	Color of Wire	Signal Name
1	L	-
3	B	-

Connector No.	B103
Connector Name	JOINT CONNECTOR-B15
Connector Color	WHITE



Terminal No.	Color of Wire	Signal Name
1	P	-
3	W	-

Connector No.	B104
Connector Name	ADAS CONTROL UNIT
Connector Color	WHITE

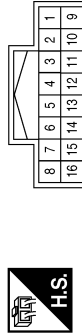

Terminal No.	Color of Wire	Signal Name
5	G	BRAKE HOLD RLY DRIVE SIGNAL
6	B	GND
7	L	CAN-H
8	Y	CAN-L
14	B	CAN-H
15	W	CAN-L
16	R	IGNITION

Connector No.	B115
Connector Name	JOINT CONNECTOR-B08
Connector Color	WHITE

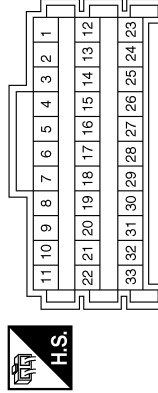

Terminal No.	Color of Wire	Signal Name
9	B	-
10	GR	-
11	SHIELD	-
19	R	-
20	R	-

Connector No.	B124
Connector Name	WIRE TO WIRE
Connector Color	WHITE

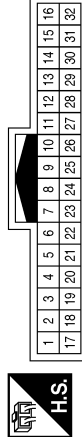

Terminal No.	Color of Wire	Signal Name
20	Y	-
21	L	-

INTELLIGENT CRUISE CONTROL

< WIRING DIAGRAM >

[ICC]

Connector No.	B147
Connector Name	JOINT CONNECTOR-B13
Connector Color	WHITE



Terminal No.	Color of Wire	Signal Name
1	Y	-
2	Y	-

Connector No.	B146
Connector Name	JOINT CONNECTOR-B12
Connector Color	WHITE



Terminal No.	Color of Wire	Signal Name
1	L	-
2	L	-

Connector No.	B136
Connector Name	WIRE TO WIRE
Connector Color	WHITE

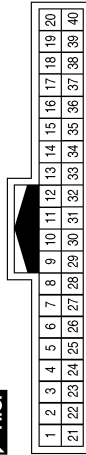

Terminal No.	Color of Wire	Signal Name
4	G	-

Connector No.	B406
Connector Name	REAR COMBINATION LAMP LH
Connector Color	GRAY



Terminal No.	Color of Wire	Signal Name
1	G	-
3	B	-

Connector No.	B404
Connector Name	WIRE TO WIRE
Connector Color	BLACK



Terminal No.	Color of Wire	Signal Name
1	B	-

Connector No.	B400
Connector Name	WIRE TO WIRE
Connector Color	WHITE

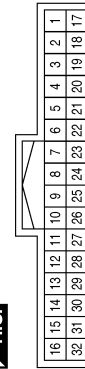

Terminal No.	Color of Wire	Signal Name
15	G	-

ABOIA0253GB

A
B
C
D
E
F
G
H
I
J
K
L
M
N
P

CCS

INTELLIGENT CRUISE CONTROL

< WIRING DIAGRAM >

[ICC]

Connector No.	D502
Connector Name	WIRE TO WIRE
Connector Color	GRAY

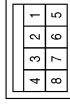

Terminal No.	Color of Wire	Signal Name
2	B	-

Connector No.	D501
Connector Name	WIRE TO WIRE
Connector Color	WHITE

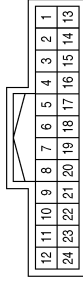

Terminal No.	Color of Wire	Signal Name
24	LG	-

Connector No.	B407
Connector Name	REAR COMBINATION LAMP RH
Connector Color	GRAY



Terminal No.	Color of Wire	Signal Name
1	G	-
3	GR	-

Connector No.	D503
Connector Name	HIGH-MOUNTED STOP LAMP
Connector Color	BROWN



Terminal No.	Color of Wire	Signal Name
1	LG	-
2	B	-

AB0IA0254GB

DIAGNOSIS AND REPAIR WORK FLOW

< BASIC INSPECTION >

[ICC]

BASIC INSPECTION

DIAGNOSIS AND REPAIR WORK FLOW

Work Flow

INFOID:000000011132069

OVERALL SEQUENCE

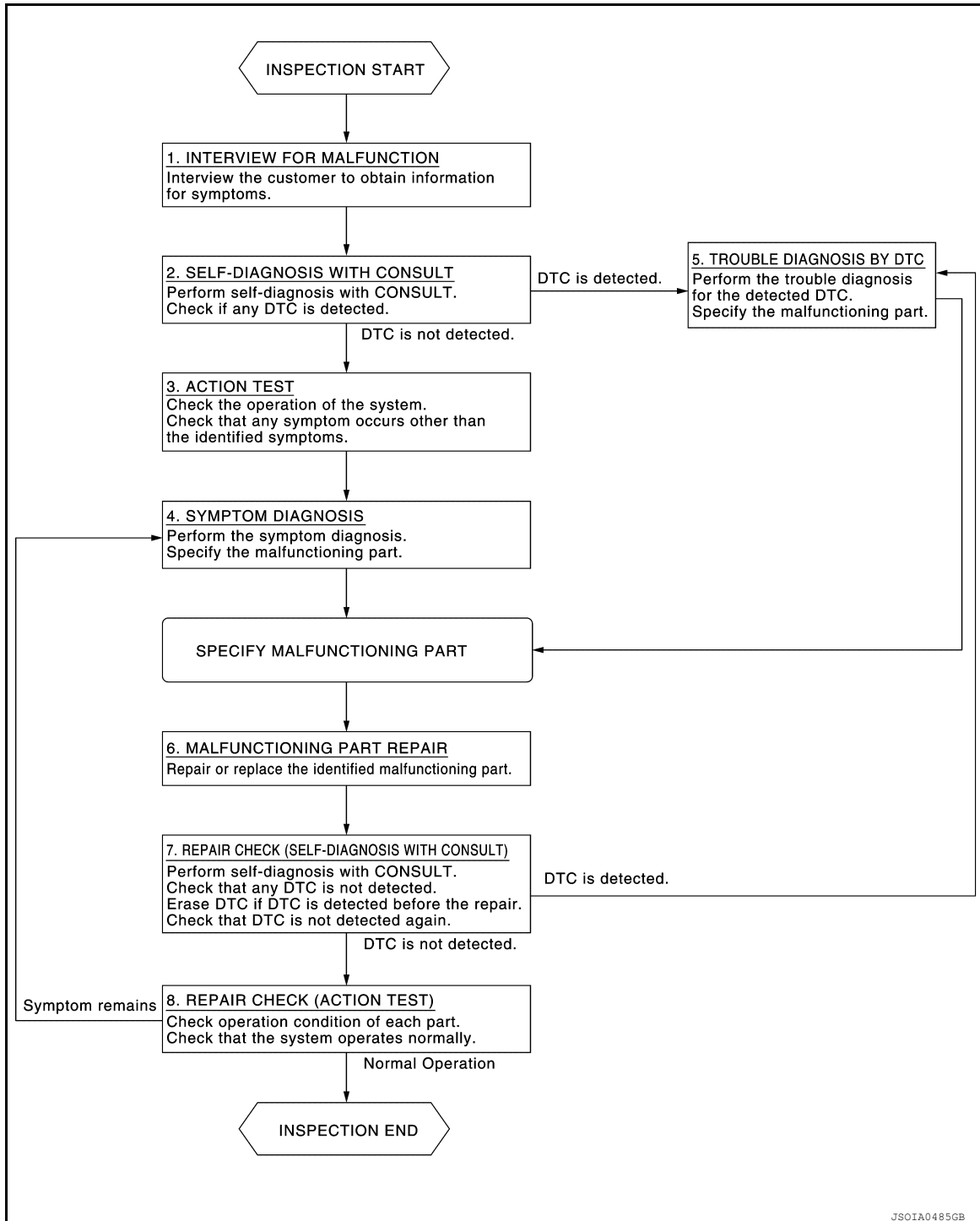

DETAILED FLOW

1. INTERVIEW FOR MALFUNCTION

It is also important to clarify the customer concerns before starting the inspection. Interview the customer about the concerns carefully and understand the symptoms fully.

A
B
C
D
E
F
G
H
I
J
K
L
M
N
P

CCS

DIAGNOSIS AND REPAIR WORK FLOW

[ICC]

< BASIC INSPECTION >

NOTE:

The customers are not professionals. Never assume that “maybe the customer means…” or “maybe the customer mentioned this symptom”.

>> GO TO 2.

2. SELF-DIAGNOSIS WITH CONSULT

1. Perform “All DTC Reading” with CONSULT.
2. Check if any DTC is detected in self-diagnosis results of “ICC/ADAS” and “LASER/RADAR”.

Is any DTC detected?

- YES >> GO TO 5.
NO >> GO TO 3.

3. ACTION TEST

Perform the ICC system action test to check the operation status. Refer to [CCS-97, "Description"](#).
Check if any other malfunctions occur.

>> GO TO 4.

4. SYMPTOM DIAGNOSIS

Perform the applicable diagnosis according to the diagnosis chart by symptom. Refer to [CCS-179, "Symptom Table"](#).

>> GO TO 6.

5. TROUBLE DIAGNOSIS BY DTC

1. Check the DTC in the self-diagnosis results.
2. Perform trouble diagnosis for the detected DTC. Refer to [CCS-60, "DTC Index"](#) (ICC/ADAS) or [CCS-66, "DTC Index"](#) (LASER/RADAR).

NOTE:

If “DTC: U1000” is detected, first diagnose the CAN communication system or ITS communication system.

>> GO TO 6.

6. MALFUNCTIONING PART REPAIR

Repair or replace the identified malfunctioning parts.

>> GO TO 7.

7. REPAIR CHECK (SELF-DIAGNOSIS WITH CONSULT)

1. Erases self-diagnosis results.
2. Perform “All DTC Reading” again after repairing or replacing the malfunctioning parts.
3. Check if any DTC is detected in self-diagnosis results of “ICC/ADAS” and “LASER/RADAR”.

Is any DTC detected?

- YES >> GO TO 5.
NO >> GO TO 8.

8. REPAIR CHECK (ACTION TEST)

Perform the ICC system action test. Check if the malfunction symptom is solved or no other symptoms occur.

Is there any malfunction symptom?

- YES >> GO TO 4.
NO >> INSPECTION END

ADDITIONAL SERVICE WHEN REPLACING ICC SENSOR

< BASIC INSPECTION >

[ICC]

ADDITIONAL SERVICE WHEN REPLACING ICC SENSOR

Description

INFOID:0000000011132070

- Always perform the radar alignment aiming adjustment after removing and installing or replacing the ICC sensor.

CAUTION:

The system does not operate normally unless the ICC sensor is aligned properly.

- Perform the ICC system action test to check that the ICC system operates normally.

Work Procedure

INFOID:0000000011132071

1. RADAR ALIGNMENT ADJUSTMENT

Adjust the radar alignment. Refer to [CCS-89, "Description"](#).

>> GO TO 2.

2. ICC SYSTEM ACTION TEST

1. Perform the ICC system action test. Refer to [CCS-97, "Description"](#).
2. Check that the ICC system operates normally.

>> Inspection End.

A
B
C
D
E
F
G
H
I
J
K
L
M
N
P

CCS

ICC SENSOR INITIAL VERTICAL ALIGNMENT

< BASIC INSPECTION >

[ICC]

ICC SENSOR INITIAL VERTICAL ALIGNMENT

Description

INFOID:000000011132072

WARNING:

Radio waves could adversely affect electric medical equipment. Those who use a pacemaker should contact the electric medical equipment manufacturer for the possible influences before use.

OUTLINE OF ICC SENSOR INITIAL ALIGNMENT PROCEDURE

- Always perform the ICC sensor initial vertical alignment after removing and installing or replacing the ICC sensor.

CAUTION:

The system does not operate normally unless the ICC sensor is aligned properly.

1. Required tools, refer to [CCS-86, "Required Tools"](#).
2. Preparation, refer to [CCS-86, "Preparation"](#).
3. ICC sensor initial vertical alignment, refer to [CCS-87, "ICC Sensor Initial Vertical Alignment"](#).

CAUTIONARY POINT FOR ICC SENSOR ALIGNMENT PROCEDURE

CAUTION:

- For ICC sensor alignment procedure, choose a level location with a few feet of working space in front and surrounding the vehicle.
- Vehicle must be stationary and unoccupied during the whole alignment procedure.
- Never enter the vehicle during ICC sensor alignment.
- For proper system operation and adjustment, all vehicle wheels must be the original factory size.

The ICC sensor requires alignment whenever the ICC sensor is removed and reinstalled and whenever front end structural repairs are performed. ICC sensor alignment consists of performing the mechanical vertical alignment (ICC sensor initial vertical alignment) described in the following procedure, followed by the electronic horizontal alignment (ICC sensor alignment) that is performed using CONSULT and the appropriate special service tools.

Required Tools

INFOID:000000011132073

The following ICC sensor cone alignment tool J-51093 is necessary to perform the ICC sensor initial vertical alignment:

- ICC sensor cone alignment tool.
 1. Center release button
 2. Plunger
 3. Level
 4. Suction cup

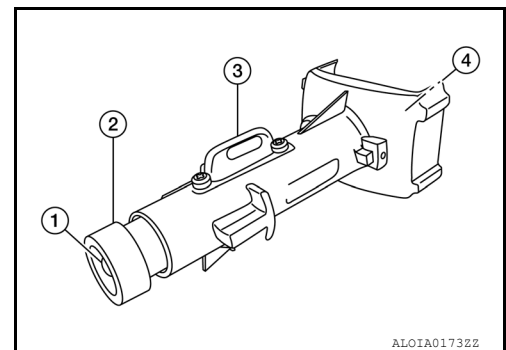

Preparation

INFOID:000000011132074

1. PREPARATION FOR ICC SENSOR INITIAL VERTICAL ALIGNMENT PROCEDURE

1. Verify correct vehicle suspension height. Refer to [WT-61, "Road Wheel"](#).
2. Repair or replace any damaged body components.
3. Verify proper tire inflation pressures. Refer to [WT-61, "Tire Air Pressure"](#).
4. Remove any accumulations of mud, snow or ice from the vehicle underbody.
5. Verify that there is no load in the vehicle (cargo or passenger).
6. Place the vehicle on a known level horizontal surface such as a wheel or frame alignment rack to achieve satisfactory sensor vertical alignment results.
7. Remove front fascia if required. Refer to [EXT-17, "Removal and Installation"](#).

ICC SENSOR INITIAL VERTICAL ALIGNMENT

< BASIC INSPECTION >

[ICC]

>> Refer to [CCS-87, "ICC Sensor Initial Vertical Alignment"](#).

ICC Sensor Initial Vertical Alignment

INFOID:000000011132075

NOTE:

The ICC sensor initial vertical alignment procedure must be performed anytime the ICC sensor is removed and reinstalled or replaced.

1. The ICC sensor (1) is located near the right front bumper behind the front fascia.
2. Using standard glass cleaner and a clean soft towel, remove any dirt from the ICC sensor lens and from the suction cup of the vertical alignment tool.

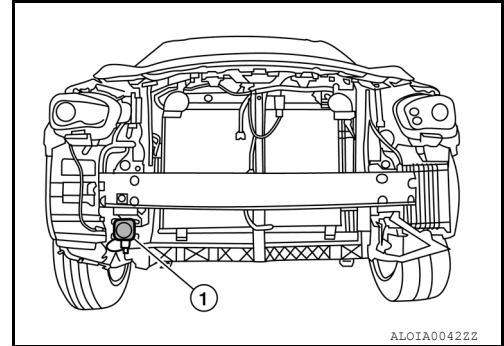

3. With the level indicator facing upward, carefully slide the vertical alignment tool over the sensor housing until the suction cup rests against the lens of the sensor.

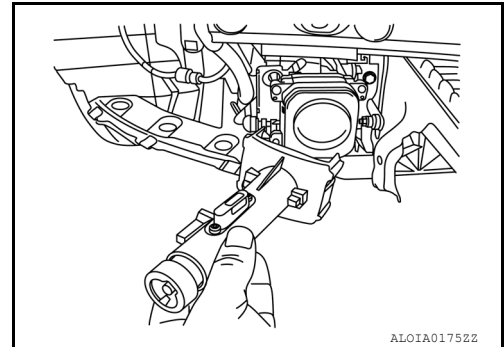

4. Depress the plunger of the vertical alignment tool (1) to engage the suction cup and attach the tool securely to the lens of the sensor.

NOTE:

It may take several attempts to get the suction cup of the tool to fasten securely to the sensor. If necessary, lightly wet the suction cup with clean water to help improve adhesion.

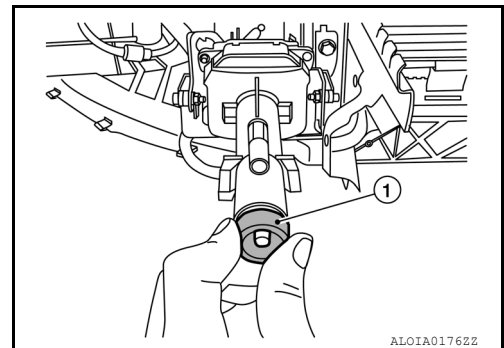

5. Turn the ICC sensor adjustment screw (1) to level the tool.

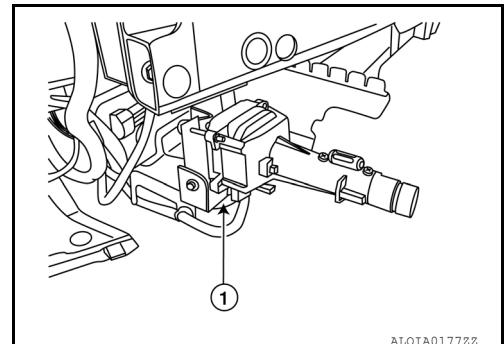

A
B
C
D
E
F
G
H
I
J
K
L
M
N
P

CCS

ICC SENSOR INITIAL VERTICAL ALIGNMENT

[ICC]

< BASIC INSPECTION >

6. Depress the center release button of the tool (1) to release the suction cup from the sensor lens and remove the tool from the sensor.
7. Insure the ICC sensor electrical connector located on the bottom of the sensor is connected.
8. Reinstall the front fascia.
9. Perform the ICC sensor alignment procedure. Refer to [CCS-89](#). "[Description](#)".

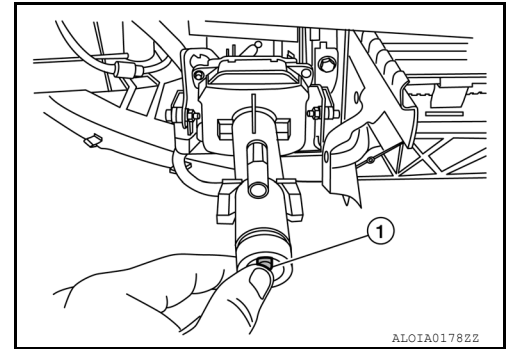

ALOIA01782Z

ICC SENSOR ALIGNMENT

< BASIC INSPECTION >

[ICC]

ICC SENSOR ALIGNMENT

Description

INFOID:000000011132076

WARNING:

Radio waves could adversely affect electric medical equipment. Those who use a pacemaker should contact the electric medical equipment manufacturer for the possible influences before use.

OUTLINE OF ICC SENSOR ALIGNMENT PROCEDURE

- A 4-wheel vehicle alignment must be performed before proceeding with ICC sensor alignment procedure.
- Always perform the ICC sensor alignment after removing and installing or replacing the ICC sensor.
- If the ICC sensor was removed and installed or replaced, first perform ICC Sensor Initial Vertical Alignment, refer to [CCS-86, "Description"](#).

CAUTION:

The system does not operate normally unless the ICC sensor is aligned properly.

1. Required tools, refer to [CCS-89, "Required Tools"](#).
2. Preparation, refer to [CCS-90, "Preparation"](#).
3. Vehicle set up, refer to [CCS-91, "Vehicle Set Up"](#).
4. Setting the ICC target board, refer to [CCS-93, "Setting The ICC Target Board"](#).
5. ICC sensor adjustment, refer to [CCS-94, "ICC Sensor Adjustment"](#).

CAUTIONARY POINT FOR ICC SENSOR ALIGNMENT PROCEDURE

CAUTION:

- For ICC sensor alignment procedure, choose a level location with a few feet of working space in front and surrounding the vehicle.
- Vehicle must be stationary and unoccupied during the whole alignment procedure.
- Any slight vibration during the alignment procedure can cause the test to fail. If this happens, you will have to restart the alignment process.
- The ignition switch must be in the ON position.
- The battery voltage must not fall below 12 volts during the whole alignment procedure. Failure to maintain adequate battery voltage will cause the test to fail. If this happens, you will have to restart the alignment process.
- The ICC target board must be set in front of the vehicle facing the sensor.
- Adjust the ICC sensor alignment with CONSULT. (The ICC sensor alignment procedure cannot be adjusted without CONSULT.)
- Never enter the vehicle during ICC sensor alignment.
- Never block the area between the ICC sensor and the ICC target board at any time during the alignment process.
- Never break the laser beam between the laser assembly and front ICC target board or rear reflector at any time during alignment.
- Accurate steering wheel setting is crucial. Once set, do not disturb the steering wheel for the remainder of the alignment procedure.
- To avoid physical damage, the ICC sensor adjustment screw must not be forced to either clockwise or counter-clockwise limit. For proper adjustment procedure, follow the directions of the CONSULT exactly as instructed.
- For proper system operation and adjustment, all vehicle wheels must be of the same size.

Required Tools

INFOID:000000011132077

- ICC alignment kit 1-20-2721-1-IF in addition to one of the following:
 - a) Hunter self-centering wheel adapter (Hunter wheel alignment tool)
 - b) Special Service Tool kit 1-20-2722-1-IF (kit SCA W/Tire Clamp-ICC Aiming)

The following ICC alignment kit 1-20-2721-1-IF is necessary to perform the ICC sensor alignment:

A

B

C

D

E

F

G

H

I

J

K

L

M

N

CCS

P

ICC SENSOR ALIGNMENT

[ICC]

< BASIC INSPECTION >

- ICC target board.
 - Position 1, with top tilted 2° toward vehicle (1).
 - Position 2, vertical (2).
 - Position 3, with top tilted 2° away from vehicle (3).

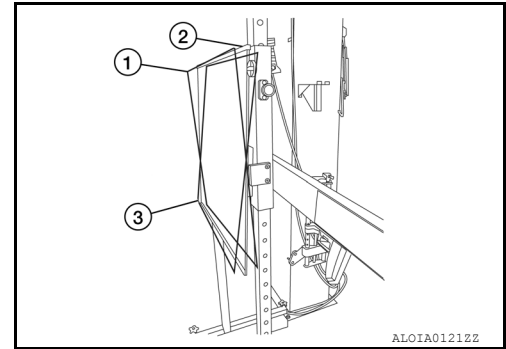

- Hunter self-centering wheel adapter (1) [shown with laser assembly (2) installed] (Hunter alignment rack head may be substituted).

NOTE:

Retailers that are not equipped with a Hunter self-centering wheel adapter will require the following kit:
Part No. 1-20-2722-1-IF (kit SCA W/Tire Clamp-ICC Aiming)

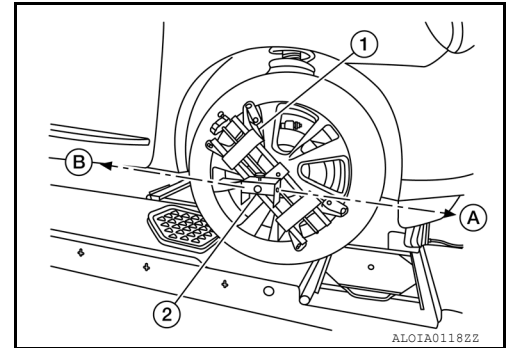

- Laser assembly (with bi-directional laser beam) as shown in the illustration.

- Tightening knob (1)
- Power ON/OFF button (2)
- Front laser beam opening (3)
- Rear laser beam opening (4)
- Attaching shaft (5)

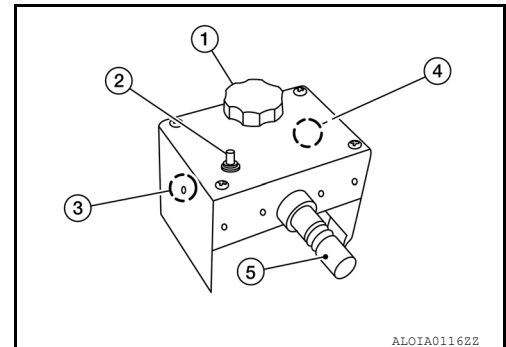

- Stationary target as shown in the illustration.

- Stationary target (1)
- Laser signal reception plate (2)

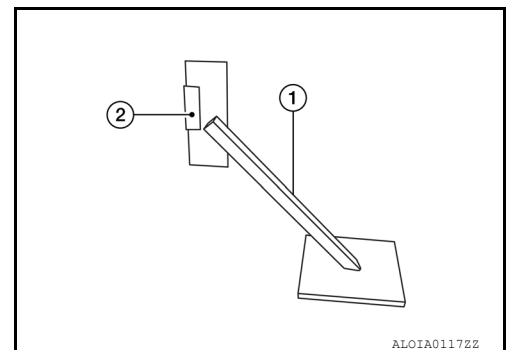

- Distance chain (not shown).

Preparation

INFOID:000000011132078

1. ADVANCE PREPARATION FOR ICC SENSOR ALIGNMENT PROCEDURE

1. Adjust all tire pressure to the specified value.
2. Empty the vehicle. (Remove any luggage from the passenger compartment, luggage room, etc.)
3. Shift the selector lever to "P" position, and release the parking brake.
4. Fully fill the fuel tank, and then check that the coolant and oils are filled up to correct level.
5. Clean off the right front side of the fascia in front of the ICC sensor.

ICC SENSOR ALIGNMENT

< BASIC INSPECTION >

[ICC]

NOTE:

The ICC sensor is located behind the fascia and it is not exposed to the elements. Therefore it should not require any cleaning.

1 : ICC sensor

>> Refer to [CCS-91. "Vehicle Set Up"](#).

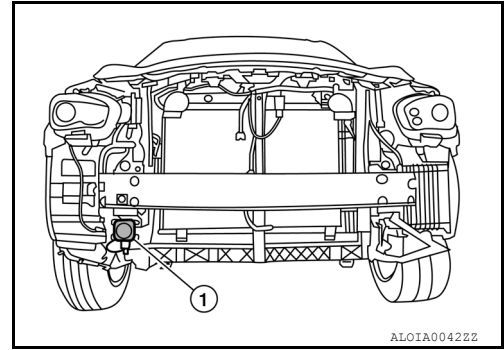

INFOID:000000011132079

Vehicle Set Up

DESCRIPTION

Accurate adjustment of the ICC sensor alignment requires that the ICC target board, wheel adapter, laser assembly, and stationary target be properly positioned.

CAUTION:

If the ICC sensor alignment is adjusted with the ICC target board, wheel adapter, laser assembly, or stationary target in the incorrect position, the ICC system will not function properly or the alignment procedure may not be completed successfully.

1. PREPOSITION TARGET BOARD

NOTE:

- The center of the sensor wave axis (A) is located at the center of the front lens.

B : Up-down direction adjusting screw

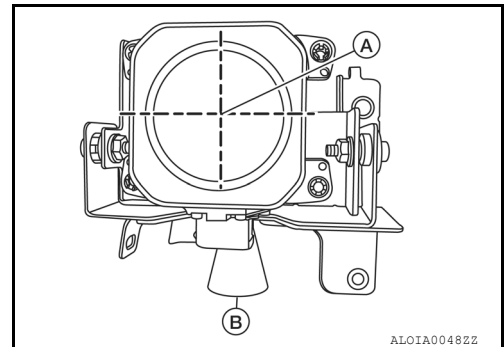

- To locate the ICC sensor, and to identify the sensor wave axis center (A) easily, measure 4.5 in (115 mm) (H) down from the center of the recovery hook cover, and 0.5 in (13 mm) (W) to the right when viewed from the front of the vehicle.

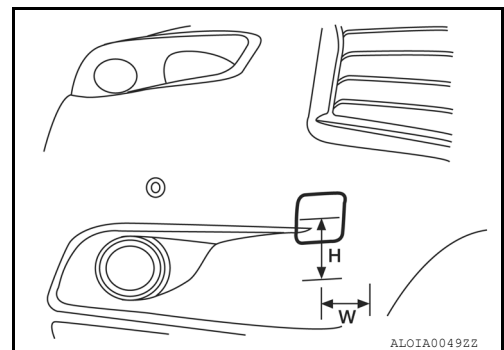

- Initial ICC target board setting must be in the center position.

A
B
C
D
E
F
G
H
I
J
K
L
M
N
P

CCS

ICC SENSOR ALIGNMENT

[ICC]

< BASIC INSPECTION >

1. Position the ICC target board in front facing the right front side of the vehicle:
 - Using the full length of the supplied chain for distance, place the marked center of the ICC target board (1) 1375 mm (54.1 in.) \pm 625 mm (24.6 in) facing the ICC sensor.
 - Adjust the height of the ICC target board using the adjustable nut (2) to achieve the proper height. The up/down tolerance is \pm 80 mm (3.15 in).
 - Adjust the ICC target board lateral position aligning the marked center of the board horizontally with the center of the ICC sensor front lens. The right/left tolerance is \pm 80 mm (3.15 in).
2. Extend the machined arm of the ICC target board exposing the reflective surface (3) to the right front side of the vehicle.
3. Place one side of the laser assembly (2) flush against the center of the ICC target board (1) to assist in the positioning.

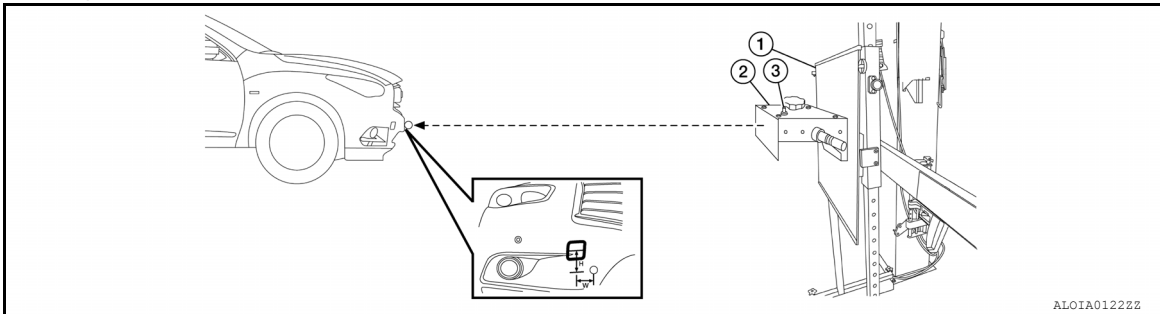
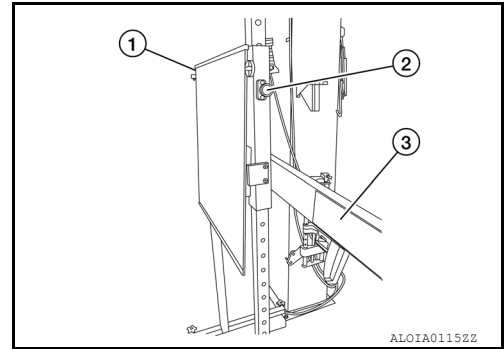

4. Turn the laser assembly ON (3) allowing the laser beam to emit through the opening of the laser assembly toward the center of the ICC sensor.
5. Move the ICC target board (1) as necessary so that center of ICC target board aligns with center of ICC sensor.
6. Turn the laser assembly OFF when done.

Are you using Hunter alignment equipment?

YES >> Refer to Hunter's equipment instructions for complete vehicle set up and ICC target board setting. Then, refer to [CCS-94. "ICC Sensor Adjustment"](#).

NO >> GO TO 2.

2. INSTALLING LASER ASSEMBLY

NOTE:

- Insure the steering wheel is positioned in the center straight forward position.
- Insure all 4 vehicle wheels do not contain any physical damage.

1. Install the wheel adapter (1) on the right front wheel.
2. Mount the laser assembly (2) to the wheel adapter (1) as shown in the figure.

NOTE:

When the power switch is turned ON, the front laser signal (A) will be emitted toward the front ICC target board, and the rear laser signal (B) will be emitted toward the rear of the vehicle.

>> GO TO 3.

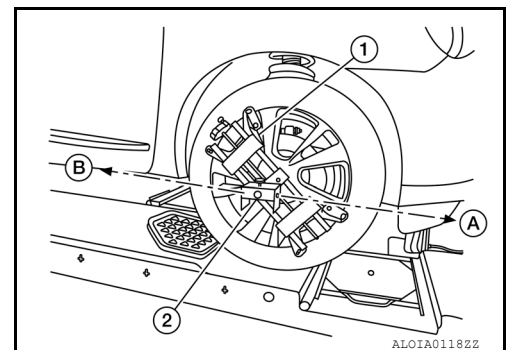

3. SETTING UP STATIONARY TARGET

ICC SENSOR ALIGNMENT

[ICC]

< BASIC INSPECTION >

1. Place the stationary target next to the right rear tire as shown in the figure.
2. Turn the laser assembly ON allowing the laser beam to be emitted through the front and rear laser assembly openings.
3. Measure and record the distance (D_r) between the edge of the right rear wheel and the laser beam (1) on the stationary target (horizontal line).
4. Measure and record the height (H_r) between the laser beam (1) on the stationary target and ground level (vertical line).

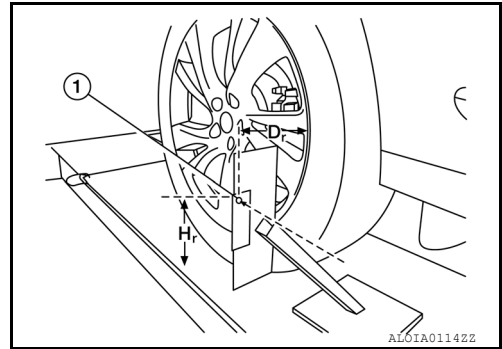

5. Measure and record the distance (D_f) between the edge of the right front wheel and the laser beam signal/opening (1) on the laser assembly (horizontal line).
6. Measure and record the height (H_f) between the laser beam signal/opening (1) on the laser assembly and ground level (vertical line).

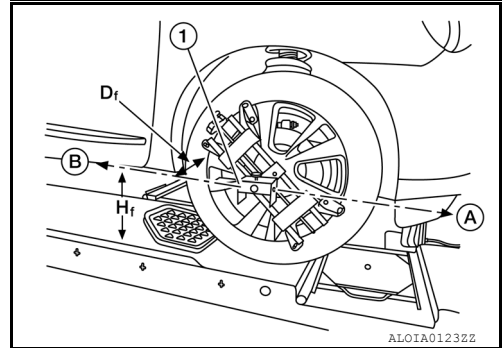

NOTE:

- Horizontal adjustment [front distance (D_f) and rear distance (D_r)] is accomplished by slowly turning the steering wheel until the 2 distances are the same.
 - Vertical adjustment [front height (H_f) and rear height (H_r)] is accomplished by rotating the laser assembly around its axis until the two heights are the same.
 - Directional arrows (A) and (B) are shown to illustrate the direction of the laser assembly beams.
7. Adjust laser beam as necessary until the two distances match and the two heights match.

NOTE:

You will have to verify both horizontal and vertical adjustments anytime one adjustment is made.

>> Refer to [CCS-93. "Setting The ICC Target Board"](#).

Setting The ICC Target Board

INFOID:000000011132080

DESCRIPTION

Accurate adjustment of the ICC sensor alignment requires that the ICC target board be accurately positioned.

CAUTION:

If the ICC sensor alignment is adjusted with the ICC target board in the incorrect position, the ICC system will not function properly or the alignment procedure may not be completed successfully.

1. ICC TARGET BOARD FINAL SETTING

1. With the ICC target board arm extended, the laser beam (1) emitted by the laser assembly (A) will be reflected back (B) toward the laser assembly.

NOTE:

When adjusted properly, reflected laser beam (B) must align with emitted laser beam (A) and the two laser beams will be seen as one.

2. Rotate the ICC target board to achieve the necessary horizontal adjustment.
3. Adjust the ICC target board leveling screws to achieve the necessary vertical adjustment.

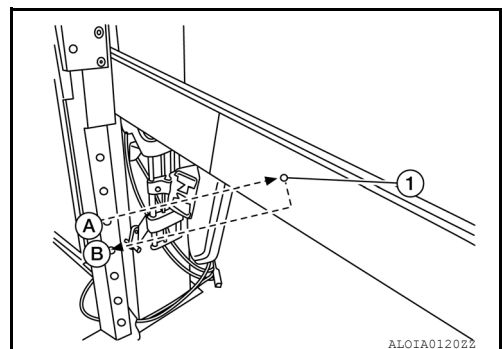

A
B
C
D
E
F
G
H
I
J
K
L
M
N
P

CCS

ICC SENSOR ALIGNMENT

[ICC]

< BASIC INSPECTION >

4. The figure shown illustrates the laser beam (A) emitted by the laser assembly (1) and its reflection (B) off of the ICC target board arm.

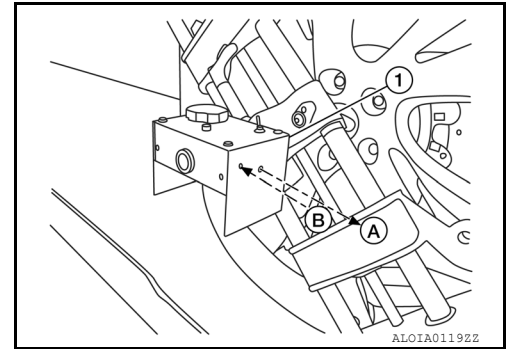

>> GO TO 2.

2. CHECK THE POSITION OF THE ICC TARGET BOARD

Do not place anything other than the ICC target board in the space shown in front of the vehicle (view from top).

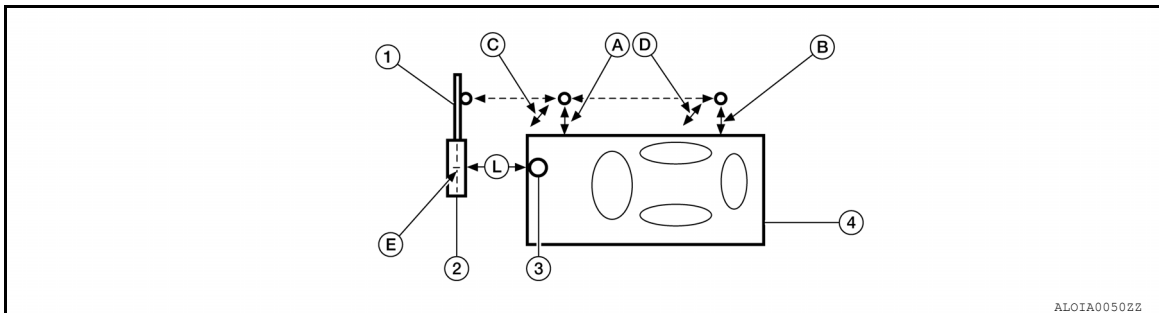

- | | | |
|---|--|---|
| 1. ICC target board arm | 2. ICC target board | 3. ICC sensor |
| 4. Vehicle | A. Distance between front wheel and laser beam (D_f) | B. Distance between rear wheel and laser beam (D_r) |
| C. Height between front laser beam and ground (H_f) | D. Height between rear laser beam and ground (H_r) | E. ICC target board center position (Position 2) |
| L. 750 - 2000 mm (29.5 - 78.7 in) | | |

>> Refer to [CCS-94. "ICC Sensor Adjustment"](#).

ICC Sensor Adjustment

INFOID:000000011132081

DESCRIPTION

- Adjust the ICC sensor alignment in a vertical direction with CONSULT as per the following.
- The ICC sensor alignment in the horizontal direction is performed automatically and cannot be adjusted manually.

CAUTION:

- **Never look directly into or block the ICC sensor source (between the front fascia and ICC target board) during the ICC sensor alignment procedure.**
- **Perform all necessary work for ICC sensor alignment procedure until the adjustment completes as shown in the procedure. If the procedure is started but not completed, the ICC system is rendered inoperable.**

1. SET CONSULT TO THE ICC SENSOR ALIGNMENT MODE

1. Place ignition switch in the ON position.
2. Connect CONSULT and select "LASER/RADAR", then "Work Support".
3. Select "RADAR Alignment".
4. Select "START" after the "RADAR Alignment" screen is displayed.

NOTE:

If the adjustment screen does not appear or an error appears within approximately 10 seconds after "RADAR Alignment" is selected, the following causes are possible.

ICC SENSOR ALIGNMENT

< BASIC INSPECTION >

[ICC]

- The ICC target board is not installed in the correct position.
- Adequate space is not secured around the ICC target board.
- The ICC sensor alignment procedure exceeds its proper installation range.
- Deformation of vehicle body.
- Deformation of unit.
- Deformation of bracket.
- The area is not suitable for the adjustment work.
- Right front side of fascia (ICC sensor view) is not clean.
- The ICC system warning lamp illuminates.
- Battery voltage is low.
- The extended arm and mirror are not stationary.

>> GO TO 2.

2. ICC SENSOR ALIGNMENT

1. Once the ICC sensor alignment procedure is started, you will be prompted by the CONSULT for the next instruction.
2. Follow all the instructions exactly as requested by the CONSULT which will include the following:
 - Adjust ICC target board to position 1 (top tilted toward vehicle)
 - Adjust ICC target board to position 2 (vertical position)
 - Adjust ICC target board to position 3 (top tilted away from vehicle)

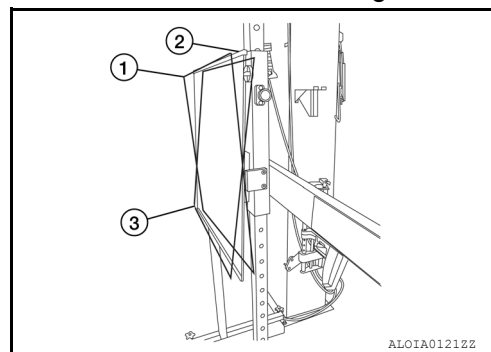

3. You will be prompted with specific instructions to perform physical adjustment to the sensor which may include turning the screw driver (A) by a certain number of turns (B) in increments of 0.25 in either direction.

NOTE:

The CONSULT is not live and will not automatically update while turning the tool.

CAUTION:

Be careful not to cover the right front side of the fascia (ICC sensor view) with a hand or any other body part during adjustment.

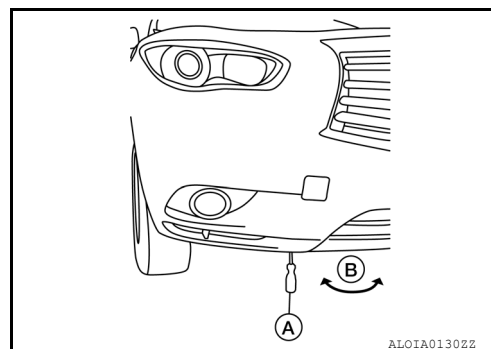

>> GO TO 3.

3. ICC SENSOR ALIGNMENT CONFIRMATION

1. When the "U/D CORRECT" value is executed and the "ADJ VALUE" has been performed, touch "END".
2. When "COMPLETED THE VERTICAL AIMING OF LASER BEAM" display appears, touch "END".

CAUTION:

Always check that the value of "U/D CORRECT" remains accurate (within specification) when the ICC sensor is left alone for at least 2 seconds.

3. Check that "ADJUSTING AUTOMATIC HORIZONTAL LASER BEAM AIMING" is displayed and wait for a short period of time. (The maximum: Approx. 10 seconds).
4. Check that "Normally Completed" is displayed, and select "End" to end "RADAR Alignment".

CAUTION:

Once "RADAR Alignment" is started with CONSULT, always continue the work until the ICC sensor alignment is completed successfully. If the job is stopped midway, the ICC sensor alignment is not completed and the ICC system is rendered inoperative.

A
B
C
D
E
F
G
H
I
J
K
L
M
N

CCS

P

ICC SENSOR ALIGNMENT

< BASIC INSPECTION >

[ICC]

5. Confirm proper ICC sensor alignment by following CONSULT steps until it shows "ADJ VALUE" to be 0.00 turn.

>> Alignment End.

ACTION TEST

Description

INFOID:000000011132082

Always perform the ICC system action test to check that the ICC system operates normally after replacing the ICC sensor or repairing any ICC system malfunction.

CAUTION:

- Always drive safely when performing the action test.
- Turn the DCA system to OFF when performing the action test.

Work Procedure (Vehicle-To-Vehicle Distance Control Mode)

INFOID:000000011132083

NOTE:

- When there is no vehicle ahead, drive at the set speed steadily.
- When there is a vehicle ahead, control to maintain distance from the vehicle ahead, watching its speed.
- The running speed can be set between 32 km/h (20 MPH) and 144 km/h (90 MPH).

CAUTION:

Never set the cruise speed exceeding the posted speed limit.

1. CHECK FOR MAIN SWITCH

1. Start the engine.
2. Press the MAIN switch (1) (less than 1.5 seconds).

Information display status

- | | | |
|---------------------------------|---|----------------|
| Set vehicle speed indicator (2) | : | “ _ _ _ ” |
| Set distance indicator (3) | : | “km/h” (“MPH”) |
| MAIN switch indicator (4) | : | Long mode |
| | : | ON |

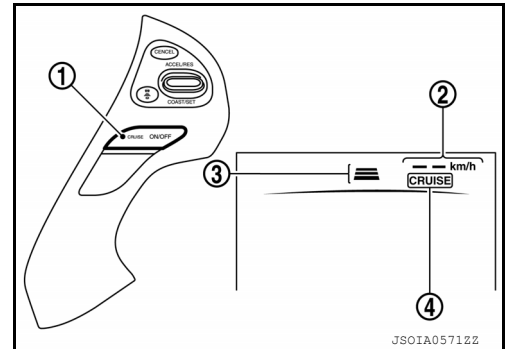

3. Check the ICC system display on the information display to check that the vehicle-to-vehicle distance control mode is ready for activation.
4. Press the MAIN switch, and check that the ICC system display on the information display turns OFF when the ICC system is deactivated.
5. Check that the ICC system display on the information display turns OFF after starting the engine again.

>> GO TO 2.

2. CHECK FOR DISTANCE SWITCH

1. Start the engine.
2. Press the MAIN switch (less than 1.5 seconds).
3. Press the DISTANCE switch.



A
B
C
D
E
F
G
H
I
J
K
L
M
N
P

ACTION TEST

< BASIC INSPECTION >

[ICC]

4. Check that the set distance indicator changes display in order of: (Long)→(Middle)→(Short).

Distance	Display	Approximate distance at 100 km/h (60 MPH) [m (ft)]
Long	 100 km/h	55 (180)
Middle	 100 km/h	40 (130)
Short	 100 km/h	25 (80)

J501A0572GB

NOTE:

When the MAIN switch is turned ON, initial setting set to (Long).

>> GO TO 3.

3. CHECK FOR RESUME/ACCELERATE, SET/COAST, AND CANCEL SWITCHES

1. Check that RESUME/ACCELERATE, SET/COAST, CANCEL switches are operated smoothly.
2. Check that switches come up as hand is released from the switches.

>> GO TO 4.

4. SET CHECKING (1)

1. Start the engine.
2. Press the MAIN switch (less than 1.5 seconds) and turn the vehicle-to-vehicle distance control mode ON.
3. Drive the vehicle at 32 km/h (20 MPH) or more.
4. Push down the SET/COAST switch.
5. Check that the desired speed is set and vehicle-to-vehicle distance control mode control starts when releasing SET/COAST switch.

NOTE:

The set vehicle speed is indicated on the set vehicle speed indicator in the ICC system display on the information display.

>> GO TO 5.

5. CHECK FOR INCREASE OF CRUISING SPEED (1)

1. Set the vehicle-to-vehicle distance control mode at desired speed.
2. Check that the set speed increases by 1 km/h (1 MPH) as RESUME/ACCELERATE switch is pushed up.

NOTE:

The maximum set speed of the vehicle-to-vehicle distance control mode is 144 km/h (90 MPH).

CAUTION:

Never set the cruise speed exceeding the posted speed limit.

>> GO TO 6.

6. CHECK FOR DECREASE OF CRUISING SPEED (1)

1. Set the vehicle-to-vehicle distance control mode at desired speed.
2. Check that the set speed decreases by 1 km/h (1 MPH) as SET/COAST switch is pushed down.

NOTE:

- The minimum set speed is approximately 32 km/h (20 MPH).

ACTION TEST

< BASIC INSPECTION >

[ICC]

- Cancel the control automatically when the vehicle speed is less than approximately 24 km/h (15 MPH) and when the system does not detect any vehicle ahead.

>> GO TO 7.

7.SET CHECKING (2)

1. Stop the vehicle.
2. Drive the vehicle at less than approximately 32 km/h (20 MPH).
3. Push down the SET/COAST switch when the system detects a vehicle ahead.
4. Check that the vehicle-to-vehicle distance control mode is performed so that the vehicle maintains a proper distance according to the vehicle speed [maximum: approximately 32 km/h (20 MPH)] when releasing SET/COAST switch.

NOTE:

- The vehicle-to-vehicle distance control mode cannot be set when the vehicle speed is less than 32 km/h (20 MPH) and when a vehicle ahead is not detected.
- Cancel the control automatically when the vehicle speed is 24 km/h (15 MPH) or less during the control and when the system does not detect any vehicle ahead.
- The set vehicle speed indicator in the ICC system display on the information display is set to 32 km/h (20 MPH).

>> GO TO 8.

8.CHECK FOR INCREASE OF CRUISING SPEED (2)

1. Set the vehicle-to-vehicle distance control mode when the vehicle speed is less than approximately 32 km/h (20 MPH) and when a vehicle ahead is detected.
2. Check that the set speed increases by 1 km/h (1 MPH) as RESUME/ACCELERATE switch is pushed up.

NOTE:

The maximum set speed of the vehicle-to-vehicle distance control mode is 144 km/h (90 MPH).

CAUTION:

Never set the cruise speed exceeding the posted speed limit.

>> GO TO 9.

9.CHECK FOR DECREASE OF CRUISING SPEED INSPECTION (2)

1. Set the vehicle-to-vehicle distance control mode when the vehicle speed is less than approximately 32 km/h (20 MPH) and when a vehicle ahead is detected.
2. Set the set vehicle speed to the desired vehicle speed according to “check for increase of cruising speed”.
3. Check that the set speed decreases by 1 km/h (1 MPH) as SET/COAST switch is pushed down.

NOTE:

- The minimum the set speed is approximately 32 km/h (20 MPH).
- If the vehicle ahead comes to a stop, the vehicle decelerates to a standstill within the limitations of the system. The system will cancel once it judges a standstill with a warning chime.

CAUTION:

The creep occurs because the stop status is not maintained.

>> GO TO 10.

10.CHECK FOR CANCELLATION OF VEHICLE-TO-VEHICLE DISTANCE CONTROL MODE

Check that the vehicle-to-vehicle distance control mode is canceled when performing the following operations.

- When the brake pedal is depressed after vehicle-to-vehicle distance control mode is set and the vehicle is driven.
- When the selector lever is in the “N” position after vehicle-to-vehicle distance control mode is set and the vehicle is driven.
- When the MAIN switch is turned OFF after vehicle-to-vehicle distance control mode is set and the vehicle is driven.
- When the CANCEL switch is pressed after vehicle-to-vehicle distance control mode is set and the vehicle is driven.

>> GO TO 11.

A
B
C
D
E
F
G
H
I
J
K
L
M
N

CCS

P

ACTION TEST

< BASIC INSPECTION >

[ICC]

11. CHECK FOR RESTORING SPEED THAT IS SET BY VEHICLE-TO-VEHICLE DISTANCE CONTROL MODE BEFORE CANCELLATION

Check that the vehicle restores the previous speed kept before the system deactivation when performing the following operations.

- Drive the vehicle when the vehicle-to-vehicle distance control mode is set and depress the brake pedal to cancel the control. Check that the vehicle restores the previous vehicle speed kept before the system deactivation when pushing up the RESUME/ACCELERATE switch.
- Drive the vehicle when the vehicle-to-vehicle distance control mode is set and shift the selector lever to the "N" position to cancel the control. Check that the vehicle restores the previous vehicle speed kept before the system deactivation when shifting the selector lever to the "D" position and pushing up the RESUME/ACCELERATE switch.
- Drive the vehicle when the vehicle-to-vehicle distance control mode is set and press the CANCEL switch to cancel the control. Check that the vehicle restores the previous vehicle speed kept before the system deactivation when pushing up the RESUME/ACCELERATE switch.

>> INSPECTION END

Work Procedure [Conventional (Fixed Speed) Cruise Control Mode]

INFOID:000000011132084

NOTE:

The running speed can be set between 40 km/h (25 MPH) and 144 km/h (90 MPH).

CAUTION:

Never set the cruise speed exceeding the posted speed limit.

1. CHECK FOR MAIN SWITCH

1. Start the engine.
2. Press the MAIN switch (1) (1.5 seconds or more).

Information display status

MAIN switch indicator (2) : ON

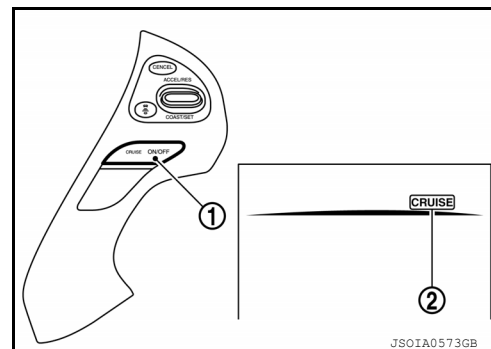

3. Check that the ICC system display on the information display turns on and the display is ready for activation.
4. Press the MAIN switch, and check that the ICC system display on the information display turns OFF when the ICC system is deactivated.
5. Check that the ICC system display on the information display turns OFF after starting the engine again.

>> GO TO 2.

2. CHECK FOR RESUME/ACCELERATE, SET/COAST, AND CANCEL SWITCHES

1. Check that RESUME/ACCELERATE, SET/COAST, CANCEL switches are operated smoothly.
2. Check that switches come up as hand is released from the switches.

>> GO TO 3.

3. SET CHECKING

1. Start the engine.
2. Press the MAIN switch (1.5 seconds or more) and turn the conventional (fixed speed) cruise control mode to ON.
3. Drive the vehicle at 40 km/h (25 MPH) or more.
4. Push down the SET/COAST switch.

ACTION TEST

< BASIC INSPECTION >

[ICC]

5. Check that the desired speed is set and conventional (fixed speed) cruise control mode control starts when releasing SET/COAST switch.

NOTE:

- The set vehicle speed is not displayed in the ICC system display on the information display.
- Display the set status in the ICC system display on the information display.

>> GO TO 4.

4.CHECK FOR INCREASE OF CRUISING SPEED

1. Set the vehicle speed to any desired speed, and drive the vehicle.
2. Check that the set speed increases by 1.6 km/h (1 MPH) as RESUME/ACCELERATE switch is pushed up.

NOTE:

- The maximum set speed is 144 km/h (90 MPH).
- The set vehicle speed increases while pushing up the RESUME/ACCELERATE switch.

CAUTION:

Never set the cruise speed exceeding the posted speed limit.

>> GO TO 5.

5.CHECK FOR DECREASE OF CRUISING SPEED

1. Set the vehicle speed to any desired speed, and drive the vehicle.
2. Check that the set speed decreases by 1.6 km/h (1 MPH) as SET/COAST switch is pushed down.

NOTE:

- The minimum set speed is 40 km/h (25 MPH).
- The set vehicle speed decreases while pressing down the SET/COAST switch.

>> GO TO 6.

6.CHECK FOR CANCELLATION OF CONVENTIONAL (FIXED SPEED) CRUISE CONTROL MODE

Check that the conventional (fixed speed) cruise control mode is canceled when performing the following operations.

- When the brake pedal is depressed after the conventional (fixed speed) cruise control mode is set and the vehicle is driven.
- When the selector lever is in the "N" position after the conventional (fixed speed) cruise control mode is set and the vehicle is driven.
- When the MAIN switch is turned OFF after the conventional (fixed speed) cruise control mode is set and the vehicle is driven.
- When the CANCEL switch is pressed after the conventional (fixed speed) cruise control mode is set and the vehicle is driven.

>> GO TO 7.

7.CHECK FOR RESTORING SPEED THAT IS SET BY CONVENTIONAL (FIXED SPEED) CRUISE CONTROL MODE BEFORE CANCELLATION

Check that the vehicle restores the previous speed kept before the system deactivation when performing the following operations.

- Drive the vehicle when the conventional (fixed speed) cruise control mode is set and depress the brake pedal to cancel the control. Check that the vehicle restores the previous vehicle speed kept before the system deactivation when pushing up the RESUME/ACCELERATE switch at the vehicle speed approximately 40 km/h (25 MPH) or more.
- Drive the vehicle when the conventional (fixed speed) cruise control mode is set and shift the selector lever is in the "N" position to cancel the control. Check that the vehicle restores the previous vehicle speed kept before the system deactivation when shifting the selector lever is in the "D" position and pushing up the RESUME/ACCELERATE switch at the vehicle speed of approximately 40 km/h (25 MPH) or more.
- Drive the vehicle when the conventional (fixed speed) cruise control mode is set and press the CANCEL switch to cancel the control. Check that the vehicle restores the previous vehicle speed kept before the system deactivation when pushing up the RESUME/ACCELERATE switch at the vehicle speed of approximately 40 km/h (25 MPH) or more.

A
B
C
D
E
F
G
H
I
J
K
L
M
N

CCS

P

ACTION TEST

< BASIC INSPECTION >

[ICC]

>> INSPECTION END

C1A00 CONTROL UNIT

< DTC/CIRCUIT DIAGNOSIS >

[ICC]

DTC/CIRCUIT DIAGNOSIS

C1A00 CONTROL UNIT

ADAS CONTROL UNIT

ADAS CONTROL UNIT : DTC Logic

INFOID:0000000011132085

DTC DETECTION LOGIC

DTC (On board display)	Trouble diagnosis name	DTC detecting condition	Possible causes
C1A00 (0)	CONTROL UNIT	ADAS control unit internal malfunction	ADAS control unit

DTC CONFIRMATION PROCEDURE

1.PERFORM DTC CONFIRMATION PROCEDURE

1. Start the engine.
2. Perform "All DTC Reading" with CONSULT.
3. Check if the "C1A00" is detected as the current malfunction in "Self Diagnostic Result" of "ICC/ADAS".

Is "C1A00" detected as the current malfunction?

- YES >> Refer to [CCS-103, "ADAS CONTROL UNIT : Diagnosis Procedure"](#).
NO >> INSPECTION END

ADAS CONTROL UNIT : Diagnosis Procedure

INFOID:0000000011132086

1.CHECK SELF-DIAGNOSIS RESULTS

Check if any DTC other than "C1A00" is detected in "Self Diagnostic Result" of "ICC/ADAS".

Is any DTC detected?

- YES >> Perform diagnosis on the detected DTC and repair or replace the malfunctioning parts. Refer to [CCS-60, "DTC Index"](#).
NO >> Replace the ADAS control unit. Refer to [DAS-85, "Removal and Installation"](#).

ICC SENSOR

ICC SENSOR : DTC Logic

INFOID:0000000011132087

DTC DETECTION LOGIC

DTC	Trouble diagnosis name	DTC detecting condition	Possible causes
C1A00	CONTROL UNIT	ICC sensor internal malfunction	ICC sensor

DTC CONFIRMATION PROCEDURE

1.PERFORM DTC CONFIRMATION PROCEDURE

1. Start the engine.
2. Perform "All DTC Reading" with CONSULT.
3. Check if the "C1A00" is detected as the current malfunction in "Self Diagnostic Result" of "LASER/RADAR".

Is "C1A00" detected as the current malfunction?

- YES >> Refer to [CCS-103, "ICC SENSOR : Diagnosis Procedure"](#).
NO >> INSPECTION END

ICC SENSOR : Diagnosis Procedure

INFOID:0000000011132088

1.CHECK SELF-DIAGNOSIS RESULTS

Check if any DTC other than "C1A00" is detected in "Self Diagnostic Result" of "LASER/RADAR".

A
B
C
D
E
F
G
H
I
J
K
L
M
N
P

C1A00 CONTROL UNIT

< DTC/CIRCUIT DIAGNOSIS >

[ICC]

Is any DTC detected?

- YES >> Perform diagnosis on the detected DTC and repair or replace the malfunctioning parts. Refer to [CCS-66. "DTC Index"](#).
- NO >> Replace the ICC sensor. Refer to [CCS-195. "Removal and Installation"](#).

C1A01 POWER SUPPLY CIRCUIT 1, C1A02 POWER SUPPLY CIRCUIT 2

< DTC/CIRCUIT DIAGNOSIS >

[ICC]

C1A01 POWER SUPPLY CIRCUIT 1, C1A02 POWER SUPPLY CIRCUIT 2 ADAS CONTROL UNIT

ADAS CONTROL UNIT : DTC Logic

INFOID:000000011132089

DTC DETECTION LOGIC

DTC (On board display)	Trouble diagnosis name	DTC detecting condition	Possible causes
C1A01 (1)	POWER SUPPLY CIR	The battery voltage sent to ADAS control unit remains less than 7.9 V for 5 seconds	• Connector, harness, fuse • ADAS control unit
C1A02 (2)	POWER SUPPLY CIR 2	The battery voltage sent to ADAS control unit remains more than 19.3 V for 5 seconds	

DTC CONFIRMATION PROCEDURE

1.PERFORM DTC CONFIRMATION PROCEDURE

1. Start the engine.
2. Turn the MAIN switch of ICC system ON.
3. Perform "All DTC Reading" with CONSULT.
4. Check if the "C1A01" or "C1A02" is detected as the current malfunction in "Self Diagnostic Result" of "ICC/ADAS".

Is "C1A01" or "C1A02" detected as the current malfunction?

- YES >> Refer to [CCS-105, "ADAS CONTROL UNIT : Diagnosis Procedure"](#).
NO >> Refer to [GI-50, "Intermittent Incident"](#).

ADAS CONTROL UNIT : Diagnosis Procedure

INFOID:000000011132090

1.CHECK ADAS CONTROL UNIT POWER SUPPLY AND GROUND CIRCUIT

Check power supply and ground circuit of ADAS control unit. Refer to [CCS-177, "ADAS CONTROL UNIT : Diagnosis Procedure"](#).

Is the inspection result normal?

- YES >> Replace the ADAS control unit. Refer to [DAS-85, "Removal and Installation"](#).
NO >> Repair or replace the malfunctioning parts.

ICC SENSOR

ICC SENSOR : DTC Logic

INFOID:000000011132091

DTC DETECTION LOGIC

DTC	Trouble diagnosis name	DTC detecting condition	Possible causes
C1A01	POWER SUPPLY CIR	The battery voltage sent to ICC sensor remains less than 7.9 V for 5 seconds	• Connector, harness, fuse • ICC sensor
C1A02	POWER SUPPLY CIR 2	The battery voltage sent to ICC sensor remains more than 19.3 V for 5 seconds	

DTC CONFIRMATION PROCEDURE

1.PERFORM DTC CONFIRMATION PROCEDURE

1. Start the engine.
2. Turn the MAIN switch of ICC system ON.
3. Perform "All DTC Reading" with CONSULT.
4. Check if the "C1A01" or "C1A02" is detected as the current malfunction in "Self Diagnostic Result" of "LASER/RADAR".

Is "C1A01" or "C1A02" detected as the current malfunction?

C1A01 POWER SUPPLY CIRCUIT 1, C1A02 POWER SUPPLY CIRCUIT 2

< DTC/CIRCUIT DIAGNOSIS >

[ICC]

YES >> Refer to [CCS-106. "ICC SENSOR : Diagnosis Procedure"](#).

NO >> Refer to [GI-50. "Intermittent Incident"](#).

ICC SENSOR : Diagnosis Procedure

INFOID:000000011132092

1. CHECK ICC SENSOR POWER SUPPLY AND GROUND CIRCUIT

Check power supply and ground circuit of ICC sensor. Refer to [CCS-177. "ICC SENSOR : Diagnosis Procedure"](#).

Is the inspection result normal?

YES >> Replace the ICC sensor. Refer to [CCS-195. "Removal and Installation"](#).

NO >> Repair or replace the malfunctioning parts.

C1A03 VEHICLE SPEED SENSOR

< DTC/CIRCUIT DIAGNOSIS >

[ICC]

C1A03 VEHICLE SPEED SENSOR

DTC Logic

INFOID:000000011132093

DTC DETECTION LOGIC

DTC (On board display)	Trouble diagnosis name	DTC detecting condition	Possible causes
C1A03 (3)	VHCL SPEED SE CIRC	If the vehicle speed signal (wheel speed) from ABS actuator and electric unit (control unit) and the CVT vehicle speed sensor signal (output shaft revolution signal) from TCM, received by the ADAS control unit via CAN communication, are inconsistent	<ul style="list-style-type: none">• Wheel speed sensor• ABS actuator and electric unit (control unit)• Vehicle speed sensor CVT (output speed sensor)• TCM• ADAS control unit

NOTE:

If DTC "C1A03" is detected along with DTC "U1000" or "C1A04", first diagnose the DTC "U1000" or "C1A04".

- Refer to [CCS-165, "ADAS CONTROL UNIT : DTC Logic"](#) for DTC "U1000".
- Refer to [CCS-109, "DTC Logic"](#) for DTC "C1A04".

DTC CONFIRMATION PROCEDURE

1. PERFORM DTC CONFIRMATION PROCEDURE

1. Start the engine.
2. Turn the MAIN switch of ICC system ON.
3. Drive the vehicle at 30 km/h (19 MPH) or more.

CAUTION:

Always drive safely.

4. Stop the vehicle.
5. Perform "All DTC Reading" with CONSULT.
6. Check if the "C1A03" is detected as the current malfunction in "Self Diagnostic Result" of "ICC/ADAS".

Is "C1A03" detected as the current malfunction?

- YES >> Refer to [CCS-107, "Diagnosis Procedure"](#).
NO >> Refer to [GI-50, "Intermittent Incident"](#).

Diagnosis Procedure

INFOID:000000011132094

1. CHECK SELF-DIAGNOSIS RESULTS

Check if "C1A04" or "U1000" is detected other than "C1A03" in "Self Diagnostic Result" of "ICC/ADAS".

Is any DTC detected?

- YES >> Perform diagnosis on the detected DTC and repair or replace the malfunctioning parts. Refer to [CCS-60, "DTC Index"](#).
NO >> GO TO 2.

2. CHECK DATA MONITOR

1. Start the engine.
2. Drive the vehicle.
3. Check that the value of "VHCL SPD AT" is almost the same as the value of "VHCL SPEED SE" in "DATA MONITOR" of "ICC/ADAS".

CAUTION:

Be careful of the vehicle speed.

Is the inspection result normal?

- YES >> Replace the ADAS control unit. Refer to [DAS-85, "Removal and Installation"](#).
NO >> GO TO 3.

3. CHECK TCM SELF-DIAGNOSIS RESULTS

1. Perform "All DTC Reading".
2. Check if any DTC is detected in "Self Diagnostic Result" of "TRANSMISSION".

A
B
C
D
E
F
G
H
I
J
K
L
M
N
P

C1A03 VEHICLE SPEED SENSOR

[ICC]

< DTC/CIRCUIT DIAGNOSIS >

Is any DTC detected?

- YES >> Perform diagnosis on the detected DTC and repair or replace the malfunctioning parts. Refer to [TM-63. "DTC Index"](#) (RE0F10E) or [TM-277. "DTC Index"](#) (RE0F10J).
- NO >> GO TO 4.

4. CHECK ABS ACTUATOR AND ELECTRIC UNIT (CONTROL UNIT) SELF-DIAGNOSIS RESULTS

Check if any DTC is detected in "Self Diagnostic Result" of "ABS".

Is any DTC detected?

- YES >> Perform diagnosis on the detected DTC and repair or replace the malfunctioning parts. Refer to [BRC-46. "DTC Index"](#).
- NO >> Replace the ADAS control unit. Refer to [DAS-85. "Removal and Installation"](#).

C1A04 ABS/TCS/VDC SYSTEM

< DTC/CIRCUIT DIAGNOSIS >

[ICC]

C1A04 ABS/TCS/VDC SYSTEM

DTC Logic

INFOID:000000011132095

DTC DETECTION LOGIC

DTC (On board display)	Trouble diagnosis name	DTC detecting condition	Possible causes
C1A04 (4)	ABS/TCS/VDC CIRC	If a malfunction occurs in the VDC/TCS/ABS system	ABS actuator and electric unit (control unit)

NOTE:

If DTC "C1A04" is detected along with DTC "U1000", first diagnose the DTC "U1000". Refer to [CCS-165, "ADAS CONTROL UNIT : DTC Logic"](#).

Diagnosis Procedure

INFOID:000000011132096

1. CHECK SELF-DIAGNOSIS RESULTS

1. Perform "All DTC Reading" with CONSULT.
2. Check if the "U1000" is detected other than "C1A04" in "Self Diagnostic Result" of "ICC/ADAS".

Is "U1000" detected?

- YES >> Perform the CAN communication system inspection. Repair or replace the malfunctioning parts. Refer to [CCS-165, "ADAS CONTROL UNIT : DTC Logic"](#).
- NO >> GO TO 2.

2. CHECK ABS ACTUATOR AND ELECTRIC UNIT (CONTROL UNIT) SELF-DIAGNOSIS RESULTS

Check if any DTC is detected in "Self Diagnostic Result" of "ABS".

Is any DTC detected?

- YES >> Perform diagnosis on the detected DTC and repair or replace the malfunctioning parts. Refer to [BRC-46, "DTC Index"](#).
- NO >> Replace the ADAS control unit. Refer to [DAS-85, "Removal and Installation"](#).

A
B
C
D
E
F
G
H
I
J
K
L
M
N
P

CCS

C1A05 BRAKE SW/STOP LAMP SW

< DTC/CIRCUIT DIAGNOSIS >

[ICC]

C1A05 BRAKE SW/STOP LAMP SW

DTC Logic

INFOID:000000011132097

DTC DETECTION LOGIC

DTC (On board display)	Trouble diagnosis name	DTC detecting condition	Possible causes
C1A05 (5)	BRAKE SW/STOP L SW	A mismatch between a stop lamp switch signal and a brake pedal position switch signal received from ECM and a stop lamp signal received from the ABS actuator and electric unit (control unit) continues for 10 seconds or more with vehicle speeds at approximately 40 km/h or more	<ul style="list-style-type: none">• Stop lamp switch circuit• Brake pedal position switch circuit• Stop lamp switch• Brake pedal position switch• Incorrect stop lamp switch installation• Incorrect brake pedal position switch installation• ECM• ABS actuator and electric unit (control unit)

NOTE:

If DTC "C1A05" is detected along with DTC "U1000", first diagnose the DTC "U1000". Refer to [CCS-165, "ADAS CONTROL UNIT : DTC Logic"](#).

Diagnosis Procedure

INFOID:000000011132098

Regarding Wiring Diagram information, refer to [CCS-68, "Wiring Diagram"](#).

1. CHECK SELF-DIAGNOSIS RESULTS

1. Perform "All DTC Reading" with CONSULT.
2. Check if the "U1000" is detected other than "C1A05" in "Self Diagnostic Result" of "ICC/ADAS".

Is "U1000" detected?

YES >> Perform the CAN communication system inspection. Repair or replace the malfunctioning parts.
Refer to [CCS-165, "ADAS CONTROL UNIT : DTC Logic"](#).

NO >> GO TO 2.

2. CHECK STOP LAMP SWITCH AND BRAKE PEDAL POSITION SWITCH

Check that "STOP LAMP SW" and "BRAKE SW" operate normally in "DATA MONITOR" of "ICC/ADAS".

Is the inspection result normal?

YES >> GO TO 3.

NO-1 >> When "BRAKE SW" operation is malfunctioning: GO TO 4.

NO-2 >> When "STOP LAMP SW" operation is malfunctioning: GO TO 9.

3. CHECK STOP LAMP SWITCH

Check that "STOP LAMP SW" operate normally in "DATA MONITOR" of "ABS".

Is the inspection result normal?

YES >> GO TO 14.

NO >> GO TO 9.

4. CHECK BRAKE PEDAL POSITION SWITCH INSTALLATION

1. Turn ignition switch OFF.
2. Check brake pedal position switch for correct installation. Refer to [BR-7, "Inspection"](#).

Is the inspection result normal?

YES >> GO TO 5.

NO >> Adjust brake pedal position switch installation. Refer to [BR-15, "Adjustment"](#).

C1A05 BRAKE SW/STOP LAMP SW

< DTC/CIRCUIT DIAGNOSIS >

[ICC]

5. BRAKE PEDAL POSITION SWITCH INSPECTION

1. Disconnect brake pedal position switch connector.
2. Check brake pedal position switch. Refer to [CCS-113. "Component Inspection \(Brake Pedal Position Switch\)"](#).

Is the inspection result normal?

- YES >> GO TO 6.
NO >> Replace brake pedal position switch.

6. CHECK BRAKE PEDAL POSITION SWITCH POWER SUPPLY CIRCUIT

1. Turn the ignition switch ON.
2. Check voltage between brake pedal position switch harness connector and ground.

Terminals		Voltage (Approx.)
(+)	(-)	
Brake pedal position switch		Ground
Connector	Terminal	
E72	1	
		Battery voltage

Is the inspection result normal?

- YES >> GO TO 7.
NO >> Repair the harnesses or connectors.

7. CHECK HARNESS BETWEEN BRAKE PEDAL POSITION SWITCH AND ECM

1. Turn ignition switch OFF
2. Disconnect ECM connector.
3. Check for continuity between brake pedal position switch harness connector and ECM harness connector.

Brake pedal position switch		ECM		Continuity
Connector	Terminal	Connector	Terminal	
E72	2	E16 (for Mexico)	126	Existed
		E32 (except for Mexico)	140	

4. Check for continuity between brake pedal position switch harness connector and ground.

Brake pedal position switch		Ground	Continuity
Connector	Terminal		
E72	2		Not existed

Is the inspection result normal?

- YES >> GO TO 8.
NO >> Repair the harnesses or connectors.

8. PERFORM SELF-DIAGNOSIS OF ECM

1. Connect all connectors again if the connectors are disconnected.
2. Turn ignition switch ON.
3. Perform "All DTC Reading".
4. Check if any DTC is detected in "Self Diagnostic Result" of "ENGINE". Refer to [EC-112. "DTC Index"](#) (except for Mexico) or [EC-636. "DTC Index"](#) (for Mexico).

Is any DTC detected?

- YES >> Repair or replace the malfunctioning parts identified by the self-diagnosis result.
NO >> Replace the ADAS control unit. Refer to [DAS-85. "Removal and Installation"](#).

9. CHECK STOP LAMP SWITCH INSTALLATION

1. Turn ignition switch OFF.
2. Check stop lamp switch for correct installation. Refer to [BR-7. "Inspection"](#).

Is the inspection result normal?

A
B
C
D
E
F
G
H
I
J
K
L
M
N

CCS

P

C1A05 BRAKE SW/STOP LAMP SW

[ICC]

< DTC/CIRCUIT DIAGNOSIS >

- YES >> GO TO 10.
NO >> Adjust stop lamp switch installation. Refer to [BR-15, "Adjustment"](#).

10.STOP LAMP SWITCH INSPECTION

1. Disconnect stop lamp switch connector.
2. Check stop lamp switch. Refer to [CCS-113, "Component Inspection \(Stop Lamp Switch\)"](#).

Is the inspection result normal?

- YES >> GO TO 11.
NO >> Replace stop lamp switch.

11.CHECK STOP LAMP SWITCH POWER SUPPLY CIRCUIT

1. Turn the ignition switch ON.
2. Check voltage between stop lamp switch harness connector and ground.

Terminals		Voltage (Approx.)
(+)	(-)	
Stop lamp switch		Ground
Connector	Terminal	
E38	1	
	3	Battery voltage

Is the inspection result normal?

- YES >> GO TO 12.
NO >> Repair the harnesses or connectors.

12.CHECK HARNESS BETWEEN STOP LAMP SWITCH AND ECM

1. Turn ignition switch OFF
2. Disconnect ECM, rear combination lamp and high-mounted stop lamp connectors.
3. Check for continuity between stop lamp switch harness connector and ECM harness connector.

Stop lamp switch		ECM		Continuity
Connector	Terminal	Connector	Terminal	
E38	2	E16 (for Mexico)	122	Existed
		E32 (except for Mexico)	139	

4. Check for continuity between stop lamp switch harness connector and ground.

Stop lamp switch		Ground	Continuity
Connector	Terminal		
E38	2		Not existed

Is the inspection result normal?

- YES >> GO TO 13.
NO >> Repair the harnesses or connectors.

13.CHECK HARNESS BETWEEN STOP LAMP SWITCH AND ABS ACTUATOR AND ELECTRIC UNIT (CONTROL UNIT)

1. Disconnect ABS actuator and electric unit (control unit) connector.
2. Check for continuity between stop lamp switch harness connector and ABS actuator and electric unit (control unit) harness connector.

Stop lamp switch		ABS actuator and electric unit (control unit)		Continuity
Connector	Terminal	Connector	Terminal	
E38	4	E125	5	Existed

C1A05 BRAKE SW/STOP LAMP SW

[ICC]

< DTC/CIRCUIT DIAGNOSIS >

3. Check for continuity between stop lamp switch harness connector and ground.

Stop lamp switch		Ground	Continuity
Connector	Terminal		
E38	4		Not existed

Is the inspection result normal?

- YES >> GO TO 14.
NO >> Repair the harnesses or connectors.

14.PERFORM SELF-DIAGNOSIS OF ECM

1. Connect all connectors again if the connectors are disconnected.
2. Turn ignition switch ON.
3. Perform "All DTC Reading".
4. Check if any DTC is detected in "Self Diagnostic Result" of "ENGINE". Refer to [EC-112, "DTC Index"](#) (except for Mexico) or [EC-636, "DTC Index"](#) (for Mexico).

Is any DTC detected?

- YES >> Repair or replace the malfunctioning parts identified by the self-diagnosis result.
NO >> GO TO 15.

15.PERFORM SELF-DIAGNOSIS OF ABS ACTUATOR AND ELECTRIC UNIT (CONTROL UNIT)

Check if any DTC is detected in "Self Diagnostic Result" of "ABS". Refer to [BRC-46, "DTC Index"](#).

Is any DTC detected?

- YES >> Repair or replace the malfunctioning parts identified by the self-diagnosis result.
NO >> Replace the ADAS control unit. Refer to [DAS-85, "Removal and Installation"](#).

Component Inspection (Brake Pedal Position Switch)

INFOID:0000000011132099

1.CHECK BRAKE PEDAL POSITION SWITCH

Check for continuity between brake pedal position switch terminals.

Terminal		Condition	Continuity
1	2	When brake pedal is depressed	Not existed
		When brake pedal is released	Existed

Is the inspection result normal?

- YES >> INSPECTION END
NO >> Replace brake pedal position switch.

Component Inspection (Stop Lamp Switch)

INFOID:0000000011132100

1.CHECK STOP LAMP SWITCH

Check for continuity between stop lamp switch terminals.

Terminal		Condition	Continuity
1	2	When brake pedal is depressed	Existed
		When brake pedal is released	Not existed
3	4	When brake pedal is depressed	Existed
		When brake pedal is released	Not existed

Is the inspection result normal?

- YES >> INSPECTION END
NO >> Replace stop lamp switch.

A
B
C
D
E
F
G
H
I
J
K
L
M
N

CCS

P

C1A06 OPERATION SW

DTC Logic

INFOID:0000000011132101

DTC DETECTION LOGIC

DTC (On board display)	Trouble diagnosis name	DTC detecting condition	Possible causes
C1A06 (6)	OPERATION SW CIRC	<ul style="list-style-type: none"> • Any switch of the ICC steering switch is detected as "ON" continuously for 60 seconds • An ON/OFF state judgment of the ICC differs between ECM and ADAS control unit, and the state continues for 2 seconds or more 	<ul style="list-style-type: none"> • ICC steering switch circuit • ICC steering switch • ECM

NOTE:

If DTC "C1A06" is detected along with DTC "U1000", first diagnose the DTC "U1000". Refer to [CCS-165, "ADAS CONTROL UNIT : DTC Logic"](#).

DTC CONFIRMATION PROCEDURE

1. PERFORM DTC CONFIRMATION PROCEDURE

1. Start the engine.
2. Wait for approximately 5 minutes after turning the MAIN switch of ICC system ON.
3. Perform "All DTC Reading" with CONSULT.
4. Check if the "C1A06" is detected as the current malfunction in "Self Diagnostic Result" of "ICC/ADAS".

Is "C1A06" detected as the current malfunction?

- YES >> Refer to [CCS-114, "Diagnosis Procedure"](#).
 NO >> Refer to [GI-50, "Intermittent Incident"](#).

Diagnosis Procedure

INFOID:0000000011132102

Regarding Wiring Diagram information, refer to [CCS-68, "Wiring Diagram"](#).

1. CHECK SELF-DIAGNOSIS RESULTS

Check if "U1000" is detected other than "C1A06" in "Self Diagnostic Result" of "ICC/ADAS".

Is "U1000" detected?

- YES >> Perform the CAN communication system inspection. Repair or replace the malfunctioning parts.
 Refer to [CCS-165, "ADAS CONTROL UNIT : DTC Logic"](#).
 NO >> GO TO 2.

2. CHECK ICC STEERING SWITCH

1. Turn the ignition switch OFF.
2. Disconnect the ICC steering switch connector.
3. Check the ICC steering switch. Refer to [CCS-115, "Component Inspection"](#).

Is the inspection result normal?

- YES >> GO TO 3.
 NO >> Replace the ICC steering switch.

3. CHECK HARNESS BETWEEN SPIRAL CABLE AND ECM

1. Disconnect the ECM connector.
2. Check for continuity between the spiral cable harness connector and ECM harness connector.

Spiral cable		ECM		Continuity
Connector	Terminal	Connector	Terminal	

< DTC/CIRCUIT DIAGNOSIS >

M30	25	E16 (for Mexico)	101	Existed
	32		108	
	25	E32 (except for Mexico)	134	
	32		135	

3. Check for continuity between spiral cable harness connector and ground.

Spiral cable		Ground	Continuity
Connector	Terminal		
M30	25		Not existed
	32		

Is the inspection result normal?

- YES >> GO TO 4.
- NO >> Repair the harnesses or connectors.

4. CHECK SPIRAL CABLE

Check for continuity between spiral cable terminals.

Spiral cable		Continuity
Terminal		
13	25	Existed
16	32	

Is the inspection result normal?

- YES >> GO TO 5.
- NO >> Replace the spiral cable.

5. PERFORM SELF-DIAGNOSIS OF ECM

1. Connect the connectors of ICC steering switch and ECM connector.
2. Turn the ignition switch ON.
3. Perform "All DTC Reading".
4. Check if any DTC is detected in "Self Diagnostic Result" of "ENGINE".

Is any DTC detected?

- YES >> Perform self-diagnosis on the detected DTC and repair or replace the malfunctioning parts. Refer to [EC-112. "DTC Index"](#) (except for Mexico) or [EC-636. "DTC Index"](#) (for Mexico).
- NO >> Replace the ADAS control unit. Refer to [DAS-85. "Removal and Installation"](#).

Component Inspection

INFOID:0000000011132103

1. CHECK ICC STEERING SWITCH

Check resistance between ICC steering switch terminals.

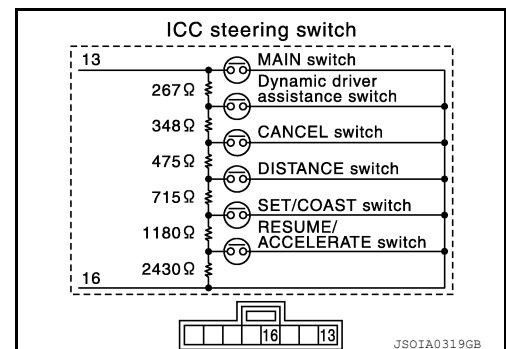

A
B
C
D
E
F
G
H
I
J
K
L
M
N
P

CCS

C1A06 OPERATION SW

< DTC/CIRCUIT DIAGNOSIS >

[ICC]

Terminal	Switch operation	Resistance [Ω]
13 16	When pressing MAIN switch	Approx. 0
	When pressing dynamic driver assistance switch	Approx. 267
	When pressing CANCEL switch	Approx. 615
	When pressing DISTANCE switch	Approx. 1090
	When pressing SET/COAST switch	Approx. 1805
	When pressing RESUME/ACCELERATE switch	Approx. 2985
	When all switches are not pressed	Approx. 5415

Is the inspection result normal?

YES >> INSPECTION END

NO >> Replace the ICC steering switch.

C1A12 LASER BEAM OFF CENTER

< DTC/CIRCUIT DIAGNOSIS >

[ICC]

C1A12 LASER BEAM OFF CENTER

DTC Logic

INFOID:0000000011132104

DTC DETECTION LOGIC

DTC (On board display)	Trouble diagnosis name	DTC detecting condition	Possible causes
C1A12 (12)	LASER BEAM OFFCNTR	Radar of ICC sensor is off the aiming point	Radar is off the aiming point

Diagnosis Procedure

INFOID:0000000011132105

1. CHECK ICC SENSOR SELF DIAGNOSIS RESULTS

1. Perform "All DTC Reading" with CONSULT.
2. Check if the "C1A12" is detected as the current malfunction in "Self Diagnostic Result" of "LASER/RADAR".

Is "C1A12" detected?

- YES >> Refer to [CCS-117, "DTC Logic"](#).
NO >> GO TO 2.

2. VISUAL INSPECTION

1. Remove the front bumper. Refer to [EXT-17, "Removal and Installation"](#).
2. Check ICC sensor and ICC sensor bracket for damage or looseness.

Does damage or looseness exist?

- YES >> 1. Repair or replace effected components. Refer to [CCS-195, "Removal and Installation"](#).
2. Perform ICC sensor alignment. Refer to [CCS-89, "Description"](#).
3. Perform action test. Refer to [CCS-97, "Description"](#).
NO >> GO TO 3.

3. CHECK ADAS CONTROL SELF DIAGNOSIS RESULTS 1

Check if the "C1A12" is detected as the current malfunction in "Self Diagnostic Result" of "ICC/ADAS".

Is "C1A12" detected?

- YES >> Replace ICC sensor. Refer to [CCS-195, "Removal and Installation"](#).
NO >> Inspection End

4. CHECK ADAS CONTROL SELF DIAGNOSIS RESULTS 2

1. Perform action test. Refer to [CCS-97, "Description"](#).
2. Check if the "C1A12" is detected as the current malfunction in "Self Diagnostic Result" of "ICC/ADAS".

Is "C1A12" detected?

- YES >> Replace ADAS control unit. Refer to [DAS-85, "Removal and Installation"](#).
NO >> Inspection End.

A
B
C
D
E
F
G
H
I
J
K
L
M
N
P

CCS

C1A12 RADAR OFF-CENTER

< DTC/CIRCUIT DIAGNOSIS >

[ICC]

C1A12 RADAR OFF-CENTER

DTC Logic

INFOID:000000011132106

DTC DETECTION LOGIC

DTC	Trouble diagnosis name	DTC detecting condition	Possible causes
C1A12	RADAR OFF-CENTER	Radar of ICC sensor is off the aiming point	Radar is off the aiming point

Diagnosis Procedure

INFOID:000000011132107

1. ADJUST RADAR ALIGNMENT

1. Adjust the radar alignment with CONSULT. Refer to [CCS-89, "Description"](#).
2. Perform "All DTC Reading".
3. Check if the "C1A12" is detected in "Self Diagnostic Result" of "LASER/RADAR".

Is "C1A12" detected?

- YES >> Replace the ICC sensor. Refer to [CCS-195, "Removal and Installation"](#).
NO >> INSPECTION END

C1A13 STOP LAMP RELAY

< DTC/CIRCUIT DIAGNOSIS >

[ICC]

C1A13 STOP LAMP RELAY

DTC Logic

INFOID:0000000011132108

DTC DETECTION LOGIC

DTC (On board display)	Trouble diagnosis name	DTC detecting condition	Possible causes
C1A13 (13)	STOP LAMP RLY FIX	<ul style="list-style-type: none">Stop lamp inactive state continues for 0.3 seconds or more despite the outputting of an ICC sensor ICC brake hold relay drive signalThe stop lamp remains ON for 60 seconds or more under the following conditions:<ul style="list-style-type: none">- Driving at 40 km/h or more- No stop lamp drive signal output from ICC sensor- No brake operation	<ul style="list-style-type: none">Stop lamp switch circuitBrake pedal position switch circuitICC brake hold relay circuitStop lamp switchBrake pedal position switchICC brake hold relayIncorrect stop lamp switch installationIncorrect brake pedal position switch installationECMABS actuator and electric unit (control unit)

NOTE:

If DTC "C1A13" is detected along with DTC "U1000", first diagnose the DTC "U1000". Refer to [CCS-165, "ADAS CONTROL UNIT : DTC Logic"](#).

DTC CONFIRMATION PROCEDURE

1. PERFORM DTC CONFIRMATION PROCEDURE (1)

- Start the engine.
- Perform the active test item "STOP LAMP" with CONSULT.
- Perform "All DTC Reading".
- Check if the "C1A13" is detected as the current malfunction in the "Self Diagnostic Result" of "ICC/ADAS".

Is "C1A13" detected as the current malfunction?

- YES >> Refer to [CCS-119, "Diagnosis Procedure"](#).
NO >> GO TO 2.

2. PERFORM DTC CONFIRMATION PROCEDURE (2)

- Drive at the vehicle speed of 40 km/h (25 MPH) or more for approximately 60 seconds or more without the brake pedal depressed.

CAUTION:

Always drive safely.

NOTE:

If it is outside the above condition, repeat step 1.

- Perform "All DTC Reading".
- Check if the "C1A13" is detected as the current malfunction in the "Self Diagnostic Result" of "ICC/ADAS".

Is "C1A13" detected as the current malfunction?

- YES >> Refer to [CCS-119, "Diagnosis Procedure"](#).
NO >> Refer to [GI-50, "Intermittent Incident"](#).

Diagnosis Procedure

INFOID:0000000011132109

Regarding Wiring Diagram information, refer to [CCS-68, "Wiring Diagram"](#).

1. CHECK SELF-DIAGNOSIS RESULTS

Check if "U1000" is detected other than "C1A13" in "Self Diagnostic Result" of "ICC/ADAS".

Is "U1000" detected?

C1A13 STOP LAMP RELAY

[ICC]

< DTC/CIRCUIT DIAGNOSIS >

- YES >> Perform the CAN communication system inspection. Repair or replace the malfunctioning parts.
Refer to [CCS-165, "ADAS CONTROL UNIT : DTC Logic"](#).
- NO >> GO TO 2.

2.CHECK STOP LAMP SWITCH

Check that "STOP LAMP SW" operate normally in "DATA MONITOR" of "ICC/ADAS".

Is the inspection result normal?

- YES >> GO TO 10.
NO >> GO TO 3.

3.CHECK STOP LAMP SWITCH INSTALLATION

1. Turn ignition switch OFF.
2. Check stop lamp switch for correct installation. Refer to [BR-7, "Inspection"](#).

Is the inspection result normal?

- YES >> GO TO 4.
NO >> Adjust stop lamp switch installation. Refer to [BR-15, "Adjustment"](#).

4.CHECK STOP LAMP SWITCH

1. Disconnect stop lamp switch connector.
2. Check stop lamp switch. Refer to [CCS-113, "Component Inspection \(Stop Lamp Switch\)"](#).

Is the inspection result normal?

- YES >> GO TO 5.
NO >> Replace stop lamp switch.

5.CHECK STOP LAMP FOR ILLUMINATION

1. Turn the ignition switch OFF.
2. Remove ICC brake hold relay.
3. Check that the stop lamp is illuminated by depressing the brake pedal to turn the stop lamp ON.

Is the inspection result normal?

- YES >> GO TO 6.
NO >> Check the stop lamp circuit, and repair or replace the malfunctioning parts.

6.CHECK HARNESS BETWEEN STOP LAMP SWITCH AND ECM

1. Turn the ignition switch OFF.
2. Disconnect stop lamp switch, ECM, rear combination lamp, and high-mounted stop lamp connectors.
3. Check for continuity between the stop lamp switch harness connector and the ECM harness connector.

Stop lamp switch		ECM		Continuity
Connector	Terminal	Connector	Terminal	
E38	2	E16 (for Mexico)	122	Existed
		E32 (except for Mexico)	139	

4. Check for continuity between stop lamp switch harness connector and ground.

Stop lamp switch		Ground	Continuity
Connector	Terminal		
E38	2		Not existed

Is the inspection result normal?

- YES >> GO TO 7.
NO >> Repair the harnesses or connectors.

7.CHECK ICC BRAKE HOLD RELAY CIRCUIT

1. Disconnect ECM, rear combination lamp, and high-mounted stop lamp connectors.
2. Check that the stop lamp does not illuminate when brake pedal is not depressed.

Is the inspection result normal?

- YES >> GO TO 9.

C1A13 STOP LAMP RELAY

[ICC]

< DTC/CIRCUIT DIAGNOSIS >

NO >> GO TO 8.

8.CHECK ICC BRAKE HOLD RELAY

1. Remove ICC brake hold relay
2. Check ICC brake hold relay. Refer to [CCS-124. "Component Inspection"](#).

Is the inspection result normal?

YES >> GO TO 9.

NO >> Replace ICC brake hold relay.

9.PERFORM SELF-DIAGNOSIS OF ECM

1. Connect all connectors again if the connectors are disconnected.
2. Turn ignition switch ON.
3. Perform "All DTC Reading".
4. Check if any DTC is detected in "Self Diagnostic Result" of "ENGINE". Refer to [EC-112. "DTC Index"](#) (except for Mexico) or [EC-636. "DTC Index"](#) (for Mexico).

Is any DTC detected?

YES >> Repair or replace the malfunctioning parts identified by the self-diagnosis result.

NO >> Replace ADAS control unit. Refer to [DAS-85. "Removal and Installation"](#).

10.CHECK ICC BRAKE HOLD RELAY POWER SUPPLY CIRCUIT

1. Turn ignition switch OFF.
2. Remove ICC brake hold relay.
3. Check the voltage between ICC brake hold relay harness connector and ground.

Terminal		Voltage (Approx.)
(+)	(-)	
ICC brake hold relay		Ground
Connector	Terminal	
E75	2	
		Battery voltage

Is the inspection result normal?

YES >> GO TO 11.

NO >> Repair or replace ICC brake hold relay power supply circuit.

11.CHECK HARNESS BETWEEN AND ICC BRAKE HOLD RELAY AND ADAS CONTROL UNIT

1. Disconnect ADAS control unit connectors.
2. Check for continuity between ICC brake hold relay harness connector and ECM harness connector.

ICC brake hold relay		ADAS control unit		Continuity
Connector	Terminal	Connector	Terminal	
E75	1	B104	5	Existed

3. Check for continuity between ADAS control unit harness connector and ground.

ICC brake hold relay		Ground	Continuity
Connector	Terminal		
E75	1		Not existed

Is the inspection result normal?

YES >> GO TO 12.

NO >> Repair the harnesses or connectors.

12.CHECK ADAS CONTROL UNIT STANDARD VOLTAGE

1. Connect all connectors again if the connectors are disconnected.
2. Turn ignition switch ON.

A
B
C
D
E
F
G
H
I
J
K
L
M
N
P

C1A13 STOP LAMP RELAY

[ICC]

< DTC/CIRCUIT DIAGNOSIS >

3. Perform "STOP LAMP" on "Active Test" of "ICC/ADAS", and then check the voltage between ADAS control unit harness connector and ground.

Terminal		Condition	Voltage (Approx.)
(+)	(-)		
ADAS control unit		Active Test item "STOP LAMP"	Battery voltage
Connector	Terminal		
B104	5		Off
		On	0 V

Is the inspection result normal?

YES >> GO TO 13.

NO >> Replace ADAS control unit. Refer to [DAS-85. "Removal and Installation"](#).

13. CHECK ICC BRAKE HOLD RELAY POWER SUPPLY CIRCUIT

1. Turn ignition switch OFF.
2. Check the voltage between ICC brake hold relay harness connector and ground.

Terminal		Condition	Voltage (Approx.)
(+)	(-)		
ICC brake hold relay		Ground	Battery voltage
Connector	Terminal		
E75	5		

Is the inspection result normal?

YES >> GO TO 14.

NO >> Repair or replace ICC brake hold relay power supply circuit.

14. CHECK HARNESS BETWEEN ICC BRAKE HOLD RELAY AND ECM

1. Disconnect ECM, rear combination lamp, and high-mounted stop lamp connectors and remove ICC brake hold relay.
2. Check for continuity between ICC brake hold relay harness connector and ECM harness connector.

ICC brake hold relay		ECM		Continuity
Connector	Terminal	Connector	Terminal	
E75	3	E16 (for Mexico)	122	Existed
		E32 (except for Mexico)	139	

3. Check for continuity between ICC brake hold relay harness connector and ground.

ICC brake hold relay		Ground	Continuity
Connector	Terminal		
E75	3		Not existed

Is the inspection result normal?

YES >> GO TO 15.

NO >> Repair the harnesses or connectors.

15. CHECK ICC BRAKE HOLD RELAY

1. Remove ICC brake hold relay.
2. Check ICC brake hold relay. Refer to [CCS-124. "Component Inspection"](#).

Is the inspection result normal?

YES >> GO TO 16.

C1A13 STOP LAMP RELAY

[ICC]

< DTC/CIRCUIT DIAGNOSIS >

NO >> Replace ICC brake hold relay.

16.CHECK STOP LAMP SWITCH

Check that "STOP LAMP SW" operate normally in "DATA MONITOR" of "ABS".

Is the inspection result normal?

YES >> GO TO 21.

NO >> GO TO 17.

17.CHECK STOP LAMP SWITCH INSTALLATION

1. Turn ignition switch OFF.
2. Check stop lamp switch for correct installation. Refer to [BR-7. "Inspection"](#).

Is the inspection result normal?

YES >> GO TO 18.

NO >> Adjust stop lamp switch installation. Refer to [BR-15. "Adjustment"](#).

18.CHECK STOP LAMP SWITCH

1. Disconnect stop lamp switch connector.
2. Check stop lamp switch. Refer to [CCS-113. "Component Inspection \(Stop Lamp Switch\)"](#).

Is the inspection result normal?

YES >> GO TO 19.

NO >> Replace stop lamp switch.

19.CHECK STOP LAMP SWITCH POWER SUPPLY CIRCUIT

1. Connect stop lamp switch connector.
2. Check the voltage between stop lamp switch harness connector and ground.

Terminal		Voltage (Approx.)
(+)	(-)	
Stop lamp switch		Ground
Connector	Terminal	
E38	3	
		Battery voltage

Is the inspection result normal?

YES >> GO TO 20.

NO >> Repair or replace stop lamp switch power supply circuit.

20.CHECK HARNESS BETWEEN STOP LAMP SWITCH AND ABS ACTUATOR AND ELECTRIC UNIT (CONTROL UNIT)

1. Turn the ignition switch OFF.
2. Disconnect stop lamp switch, ABS actuator and electric unit (control unit) connectors.
3. Check for continuity between the stop lamp switch harness connector and the ABS actuator and electric unit (control unit) harness connector.

Stop lamp switch		ABS actuator and electric unit (control unit)		Continuity
Connector	Terminal	Connector	Terminal	
E38	4	E125	5	Existed

4. Check for continuity between stop lamp switch harness connector and ground.

Stop lamp switch		Ground	Continuity
Connector	Terminal		
E38	4		Not existed

Is the inspection result normal?

YES >> GO TO 21.

A
B
C
D
E
F
G
H
I
J
K
L
M
N
P

C1A13 STOP LAMP RELAY

[ICC]

< DTC/CIRCUIT DIAGNOSIS >

NO >> Repair the harnesses or connectors.

21.PERFORM SELF-DIAGNOSIS OF ECM

1. Connect all connectors again if the connectors are disconnected.
2. Turn ignition switch ON.
3. Perform "All DTC Reading".
4. Check if any DTC is detected in "Self Diagnostic Result" of "ENGINE". Refer to [EC-112, "DTC Index"](#) (except for Mexico) or [EC-636, "DTC Index"](#) (for Mexico).

Is any DTC detected?

- YES >> Repair or replace the malfunctioning parts identified by the self-diagnosis result.
 NO >> GO TO 22.

22.PERFORM SELF-DIAGNOSIS OF ABS ACTUATOR AND ELECTRIC UNIT (CONTROL UNIT)

1. Connect all connectors again if the connectors are disconnected.
2. Turn ignition switch ON.
3. Perform "All DTC Reading".
4. Check if any DTC is detected in "Self Diagnostic Result" of "ABS". Refer to [BRC-46, "DTC Index"](#).

Is any DTC detected?

- YES >> Repair or replace the malfunctioning parts identified by the self-diagnosis result.
 NO >> Replace ADAS control unit. Refer to [DAS-85, "Removal and Installation"](#).

Component Inspection

INFOID:0000000011132110

1.CHECK ICC BRAKE HOLD RELAY

Apply battery voltage to ICC brake hold relay terminals 1 and 2, and then check for continuity under the following conditions.

Terminal	Condition	Continuity
3	When the battery voltage is applied	Existed
	When the battery voltage is not applied	Not existed

Is the inspection result normal?

- YES >> INSPECTION END
 NO >> Replace ICC brake hold relay.

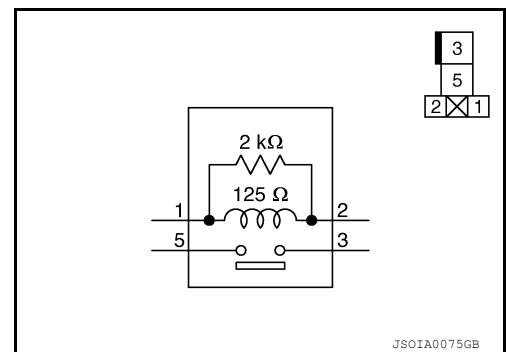

C1A14 ECM

DTC Logic

INFOID:000000011132111

DTC DETECTION LOGIC

DTC (On board display)	Trouble diagnosis name	DTC detecting condition	Possible causes
C1A14 (14)	ECM CIRCUIT	If ECM is malfunctioning	<ul style="list-style-type: none"> • Accelerator pedal position sensor • ECM • ADAS control unit

NOTE:

If DTC “C1A14” is detected along with DTC “U1000”, first diagnose the DTC “U1000”. Refer to [CCS-165, "ADAS CONTROL UNIT : DTC Logic"](#).

1. PERFORM DTC CONFIRMATION PROCEDURE

1. Start the engine.
2. Operate the ICC system and drive.
CAUTION:
Always drive safely.
3. Stop the vehicle.
4. Perform “All DTC Reading” with CONSULT.
5. Check if the “C1A14” is detected as the current malfunction in “Self Diagnostic Result” of “ICC/ADAS”.

Is “C1A14” detected as the current malfunction?

- YES >> Refer to [CCS-125, "Diagnosis Procedure"](#).
- NO >> Refer to [GI-50, "Intermittent Incident"](#).

Diagnosis Procedure

INFOID:000000011132112

1. CHECK SELF-DIAGNOSIS RESULTS

Check if “U1000” is detected other than “C1A14” in “Self Diagnostic Result” of “ICC/ADAS”.

Is “U1000” detected?

- YES >> Perform the CAN communication system inspection. Repair or replace the malfunctioning parts. Refer to [CCS-165, "ADAS CONTROL UNIT : DTC Logic"](#).
- NO >> GO TO 2.

2. PERFORM SELF-DIAGNOSIS OF ECM

Check if any DTC is detected in “Self Diagnostic Result” of “ENGINE”.

Is any DTC detected?

- YES >> Perform diagnosis on the detected DTC and repair or replace the malfunctioning parts. Refer to [EC-112, "DTC Index"](#) (except for Mexico) or [EC-636, "DTC Index"](#) (for Mexico).
- NO >> Replace the ADAS control unit. Refer to [DAS-85, "Removal and Installation"](#).

A
B
C
D
E
F
G
H
I
J
K
L
M
N
P



C1A15 GEAR POSITION

< DTC/CIRCUIT DIAGNOSIS >

[ICC]

C1A15 GEAR POSITION

Description

INFOID:0000000011132113

ADAS control unit judges the gear position based on the following signals.

- Current gear position signal transmitted from TCM via CAN communication.
- Value of gear ratio calculated from input speed signal transmitted from TCM via CAN communication.
- Value of gear ratio calculated from the vehicle speed signal transmitted from ABS actuator and electric unit (control unit) via CAN communication.

DTC Logic

INFOID:0000000011132114

DTC DETECTION LOGIC

DTC (On board display)	Trouble diagnosis name	DTC detecting condition	Possible causes
C1A15 (15)	GEAR POSITION	A mismatch between a current gear position signal transmitted from TCM via CAN communication and a gear position calculated by the ADAS control unit continues for approximately 11 minutes or more	<ul style="list-style-type: none">• Input speed sensor• Vehicle speed sensor CVT (output speed sensor)• TCM

NOTE:

If DTC "C1A15" is detected along with DTC "U1000", "C1A03", or "C1A04", first diagnose the DTC "U1000", "C1A03", or "C1A04".

- Refer to [CCS-165, "ADAS CONTROL UNIT : DTC Logic"](#) for DTC "U1000".
- Refer to [CCS-107, "DTC Logic"](#) for DTC "C1A03".
- Refer to [CCS-109, "DTC Logic"](#) for DTC "C1A04".

DTC CONFIRMATION PROCEDURE

1. PERFORM DTC CONFIRMATION PROCEDURE

1. Start the engine.
2. Turn the MAIN switch of ICC system ON.
3. Drive the vehicle at 10 km/h (6 MPH) or faster for approximately 15 minutes or more.

CAUTION:

Always drive safely.

4. Stop the vehicle.
5. Perform "All DTC Reading" with CONSULT.
6. Check if "C1A15" is detected as the current malfunction in the "Self Diagnostic Result" of "ICC/ADAS".

Is "C1A15" detected as the current malfunction?

YES >> Refer to [CCS-126, "Diagnosis Procedure"](#).

NO >> Refer to [GI-50, "Intermittent Incident"](#).

Diagnosis Procedure

INFOID:0000000011132115

1. CHECK SELF-DIAGNOSIS RESULTS

Check if "C1A03", "C1A04", or "U1000" is detected other than "C1A15" in "Self Diagnostic Result" of "ICC/ADAS".

Is any DTC detected?

YES >> Perform diagnosis on the detected DTC and repair or replace the malfunctioning parts. Refer to [CCS-60, "DTC Index"](#).

NO >> GO TO 2.

2. CHECK VEHICLE SPEED SIGNAL

Check that "VHCL SPEED SE" operates normally in "DATA MONITOR" of "ICC/ADAS".

CAUTION:

Be careful of the vehicle speed.

Is the inspection result normal?

C1A15 GEAR POSITION

[ICC]

< DTC/CIRCUIT DIAGNOSIS >

- YES >> GO TO 3.
- NO >> GO TO 7.

3.CHECK GEAR POSITION

Check that "GEAR" operates normally in "DATA MONITOR" of "ICC/ADAS".

CAUTION:

Be careful of the vehicle speed.

Is the inspection result normal?

- YES >> GO TO 5.
- NO >> GO TO 4.

4.CHECK GEAR POSITION SIGNAL

Check that "GEAR" operates normally in "DATA MONITOR" of "TRANSMISSION".

Is the inspection result normal?

- YES >> GO TO 5.
- NO >> GO TO 6.

5.CHECK INPUT SPEED SENSOR SIGNAL

Check that "INPUT SPEED" operates normally in "DATA MONITOR" of "TRANSMISSION".

Is the inspection result normal?

- YES >> Replace the ADAS control unit. Refer to [DAS-85. "Removal and Installation"](#).
- NO >> GO TO 6.

6.CHECK TCM SELF-DIAGNOSIS RESULTS

1. Perform "All DTC Reading".
2. Check if any DTC is detected in "Self Diagnostic Result" of "TRANSMISSION".

Is any DTC detected?

- YES >> Perform diagnosis on the detected DTC and repair or replace the malfunctioning parts. Refer to [TM-63. "DTC Index"](#) (RE0F10E) or [TM-277. "DTC Index"](#) (RE0F10J).
- NO >> Replace the ADAS control unit. Refer to [DAS-85. "Removal and Installation"](#).

7.CHECK ABS ACTUATOR AND ELECTRIC UNIT (CONTROL UNIT) SELF-DIAGNOSIS RESULTS

1. Perform "All DTC Reading".
2. Check if any DTC is detected in "Self Diagnostic Result" of "ABS".

Is any DTC detected?

- YES >> Perform diagnosis on the detected DTC and repair or replace the malfunctioning parts. Refer to [BRC-46. "DTC Index"](#).
- NO >> Replace the ADAS control unit. Refer to [DAS-85. "Removal and Installation"](#).

A
B
C
D
E
F
G
H
I
J
K
L
M
N
P

CCS

C1A16 RADAR STAIN

< DTC/CIRCUIT DIAGNOSIS >

[ICC]

C1A16 RADAR STAIN

DTC Logic

INFOID:0000000011132116

DTC DETECTION LOGIC

DTC	Trouble diagnosis name	DTC detecting condition	Possible causes
C1A16	RADAR STAIN	Inclusion of dirt or stains on the ICC sensor area of the front bumper	<ul style="list-style-type: none">• Stain or foreign materials is deposited• Cracks or scratches exist

NOTE:

DTC "C1A16" may be detected under the following conditions. (Explain to the customer about the difference between the contamination detection function and the indication when the malfunction is detected and tell them "This is not malfunction".)

- When contamination or foreign materials adhere to the ICC sensor area of the front bumper.
- When driving while it is snowing or when frost forms on the ICC sensor area of the front bumper.
- When ICC sensor area of the front bumper is temporarily fogged.

Diagnosis Procedure

INFOID:0000000011132117

NOTE:

After ICC sensor alignment is performed, the vehicle must be driven at a speed of 4.5 MPH (7.2 km/h) or higher for a minimum of 2 minutes before DTC C1A16 can be cleared.

1.VISUAL CHECK 1

Check the contamination and foreign matter on the ICC sensor area of the front bumper.

Does contamination or foreign matter adhere?

- YES >> Wipe out the contamination and foreign matter on the ICC sensor area of the front bumper.
NO >> GO TO 2.

2.VISUAL CHECK 2

1. Remove the front bumper. Refer to [EXT-17, "Removal and Installation"](#).
2. Check ICC sensor for contamination and foreign matter.

Does contamination or foreign matter adhere?

- YES >> Wipe out the contamination and foreign matter from the ICC sensor.
NO >> GO TO 3.

3.VISUAL CHECK 3

Check ICC sensor and ICC sensor bracket for damage or looseness.

Does damage or looseness exist?

- YES >> 1. Repair or replace effected components. Refer to [CCS-195, "Removal and Installation"](#).
2. Perform ICC sensor alignment. Refer to [CCS-89, "Description"](#).
3. Perform action test. Refer to [CCS-97, "Description"](#).
NO >> GO TO 4.

4.INTERVIEW

1. Ask if there is any trace of contamination or foreign materials adhering to the ICC sensor area of the front bumper.
2. Ask if ICC sensor area of the front bumper was frosted during driving or if vehicle was driven in snow.
3. Ask if ICC sensor area of the front bumper was temporarily fogged. (Windshield glass may also tend to fog, etc.)

Is any of above conditions seen?

- YES >> Explain to the customer about the difference between the contamination detection function and the indication when the malfunction is detected and tell them "This is not malfunction".
NO >> 1. Perform ICC sensor alignment. Refer to [CCS-89, "Description"](#).
2. Perform action test. Refer to [CCS-97, "Description"](#).
3. GO TO 5.

C1A16 RADAR STAIN

< DTC/CIRCUIT DIAGNOSIS >

[ICC]

5. CHECK ADAS CONTROL SELF-DIAGNOSIS RESULTS

Check if the "C1A16" is detected in "Self Diagnostic Result" of "ICC/ADAS"

Is "C1A16"?

- YES >> Replace the ICC sensor. Refer to [CCS-195. "Removal and Installation"](#).
- NO >> Inspection End.

A
B
C
D
E
F
G
H
I
J
K
L
M
N
P

CCS

C1A17 ICC SENSOR

< DTC/CIRCUIT DIAGNOSIS >

[ICC]

C1A17 ICC SENSOR

DTC Logic

INFOID:0000000011132118

DTC DETECTION LOGIC

DTC (On board display)	Trouble diagnosis name	DTC detecting condition	Possible causes
C1A17 (17)	ICC SENSOR MALF	If ICC sensor is malfunctioning	ICC sensor

NOTE:

If DTC "C1A17" is detected along with DTC "U1000", first diagnose the DTC "U1000". Refer to [CCS-165, "ADAS CONTROL UNIT : DTC Logic"](#).

Diagnosis Procedure

INFOID:0000000011132119

1. CHECK ADAS CONTROL UNIT SELF-DIAGNOSIS RESULTS

1. Perform "All DTC Reading" with CONSULT.
2. Check if "U1000" is detected other than "C1A17" in "Self Diagnostic Result" of "ICC/ADAS".

Is "U1000" detected?

- YES >> Perform diagnosis on the detected DTC and repair or replace the malfunctioning parts. Refer to [CCS-130, "DTC Logic"](#).
- NO >> GO TO 2.

2. CHECK ICC SENSOR SELF-DIAGNOSIS RESULTS

Check if any DTC is detected in "Self Diagnostic Result" of "LASER/RADAR".

Is any DTC detected?

- YES >> Perform diagnosis on the detected DTC and repair or replace the malfunctioning parts. Refer to [CCS-66, "DTC Index"](#).
- NO >> Replace ADAS control unit. Refer to [DAS-85, "Removal and Installation"](#).

C1A18 LASER AIMING INCOMP

< DTC/CIRCUIT DIAGNOSIS >

[ICC]

C1A18 LASER AIMING INCOMP

DTC Logic

INFOID:0000000011132120

DTC DETECTION LOGIC

DTC (On board display)	Trouble diagnosis name	DTC detecting condition	Possible causes
C1A18 (18)	LASER AIMING INCOMP	The radar of the ICC sensor is not adjusted	<ul style="list-style-type: none"> The adjustment of the radar is not yet performed Interruption in radar adjustment

DTC CONFIRMATION PROCEDURE

1. PERFORM DTC CONFIRMATION PROCEDURE

1. Start the engine.
2. Turn the MAIN switch of ICC system ON.
3. Perform "All DTC Reading" with CONSULT.
4. Check if the "C1A18" is detected as the current malfunction in "Self Diagnostic Result" of "ICC/ADAS".

Is "C1A18" detected as the current malfunction?

YES >> Refer to [CCS-131, "Diagnosis Procedure"](#).

NO >> INSPECTION END

Diagnosis Procedure

INFOID:0000000011132121

1. CHECK ICC SENSOR SELF-DIAGNOSIS RESULTS

Check if the "C1A18" is detected in "Self Diagnostic Result" of "LASER/RADAR".

Is "C1A18" detected?

YES >> Refer to [CCS-132, "DTC Logic"](#).

NO >> Replace the ADAS control unit. Refer to [DAS-85, "Removal and Installation"](#).

A
B
C
D
E
F
G
H
I
J
K
L
M
N
P

CCS

C1A18 RADAR ALIGNMENT INCOMPLETE

< DTC/CIRCUIT DIAGNOSIS >

[ICC]

C1A18 RADAR ALIGNMENT INCOMPLETE

DTC Logic

INFOID:0000000011132122

DTC DETECTION LOGIC

DTC	Trouble diagnosis name	DTC detecting condition	Possible causes
C1A18	RADAR ALIGNMENT INCOMPLETE	The radar of the ICC sensor is not adjusted	<ul style="list-style-type: none">• The adjustment of the radar is not yet performed• Interruption in radar adjustment

DTC CONFIRMATION PROCEDURE

1. PERFORM DTC CONFIRMATION PROCEDURE

1. Start the engine.
2. Turn the MAIN switch of ICC system ON.
3. Perform "All DTC Reading" with CONSULT.
4. Check if the "C1A18" is detected as the current malfunction in "Self Diagnostic Result" of "LASER/RADAR".

Is "C1A18" detected as the current malfunction?

- YES >> Refer to [CCS-132, "Diagnosis Procedure"](#).
NO >> INSPECTION END

Diagnosis Procedure

INFOID:0000000011132123

1. ADJUST RADAR ALIGNMENT

1. Adjust the radar alignment. Refer to [CCS-89, "Description"](#).
2. Erase All self-diagnosis results with CONSULT.
3. Perform "All DTC Reading".
4. Check if the "C1A18" is detected in "Self Diagnostic Result" of "LASER/RADAR".

Is "C1A18" detected?

- YES >> Replace the ICC sensor. Refer to [CCS-195, "Removal and Installation"](#).
NO >> INSPECTION END

C1A21 UNIT HIGH TEMP

< DTC/CIRCUIT DIAGNOSIS >

[ICC]

C1A21 UNIT HIGH TEMP ADAS CONTROL UNIT

ADAS CONTROL UNIT : DTC Logic

INFOID:0000000011132124

DTC DETECTION LOGIC

DTC (On board display)	Trouble diagnosis name	DTC detecting condition	Possible causes
C1A21 (21)	ICC SENSOR HIGH TEMP	ICC sensor judges high temperature abnormality	Temperature around the ICC sensor becomes high

1.PERFORM DTC CONFIRMATION PROCEDURE

1. Turn the ignition switch OFF.
2. Wait for 10 minutes or more to cool the ICC sensor.
3. Start the engine.
4. Turn the MAIN switch of ICC system ON.
5. Perform "All DTC Reading" with CONSULT.
6. Check if the "C1A21" is detected as the current malfunction in "Self Diagnostic Result" of "ICC/ADAS".

Is "C1A21" detected as the current malfunction?

- YES >> Refer to [CCS-133, "ADAS CONTROL UNIT : Diagnosis Procedure"](#).
 NO >> Refer to [GI-50, "Intermittent Incident"](#).

ADAS CONTROL UNIT : Diagnosis Procedure

INFOID:0000000011132125

1.CHECK SELF-DIAGNOSIS RESULTS

Check if "C1A21" is detected in "Self Diagnostic Result" of "LASER/RADAR".

Is "C1A21" detected?

- YES >> Perform diagnosis on the detected DTC and repair or replace the malfunctioning parts. Refer to [CCS-133, "ICC SENSOR : DTC Logic"](#).
 NO >> Replace the ADAS control unit. Refer to [DAS-85, "Removal and Installation"](#).

ICC SENSOR

ICC SENSOR : DTC Logic

INFOID:0000000011132126

DTC DETECTION LOGIC

DTC	Trouble diagnosis name	DTC detecting condition	Possible causes
C1A21	UNIT HIGH TEMP	Temperature detected by the temperature sensor integrated in ICC sensor remains less than -45 °C (-49 °F) or more than 105 °C (221 °F) for 5 seconds or more	Temperature around the ICC sensor becomes extremely low or high

DTC CONFIRMATION PROCEDURE

1.PERFORM DTC CONFIRMATION PROCEDURE

1. Turn the ignition switch OFF.
2. Wait for 10 minutes or more.
3. Start the engine.
4. Turn the MAIN switch of ICC system ON.
5. Perform "All DTC Reading" with CONSULT.
6. Check if the "C1A21" is detected as the current malfunction in "Self Diagnostic Result" of "LASER/RADAR".

Is "C1A21" detected as the current malfunction?

- YES >> Refer to [CCS-133, "ADAS CONTROL UNIT : Diagnosis Procedure"](#).

NO >> Refer to [GI-50, "Intermittent Incident"](#).

ICC SENSOR : Diagnosis Procedure

INFOID:0000000011132127

1. CHECK ENGINE COOLING SYSTEM

Check for any malfunctions in engine cooling system.

Is engine cooling system normal?

YES >> Replace the ICC sensor. Refer to [CCS-195, "Removal and Installation"](#).

NO >> Repair engine cooling system.

C1A24 NP RANGE

< DTC/CIRCUIT DIAGNOSIS >

[ICC]

C1A24 NP RANGE

DTC Logic

INFOID:0000000011132128

DTC DETECTION LOGIC

DTC (On board display)	Trouble diagnosis name	DTC detecting condition	Possible causes
C1A24 (24)	NP RANGE	A mismatch between a shift position signal transmitted from TCM via CAN communication and a current gear position signal continues for 60 seconds or more	<ul style="list-style-type: none">• TCM• Transmission range switch

NOTE:

If DTC "C1A24" is detected along with DTC "U1000", first diagnose the DTC "U1000". Refer to [CCS-165, "ADAS CONTROL UNIT : DTC Logic"](#).

DTC CONFIRMATION PROCEDURE

1. CHECK DTC REPRODUCE (1)

1. Start the engine.
2. Turn the MAIN switch of ICC system ON.
3. Wait for approximately 5 minutes or more after shifting the selector lever to "P" position.
4. Perform "All DTC Reading" with CONSULT.
5. Check if the "C1A24" is detected as the current malfunction in "Self Diagnostic Result" of "ICC/ADAS".

Is "C1A24" detected as the current malfunction?

- YES >> Refer to [CCS-135, "Diagnosis Procedure"](#).
NO >> GO TO 2.

2. CHECK DTC REPRODUCE (2)

1. Wait for approximately 5 minutes or more after shifting the selector lever to "N" position.
2. Perform "All DTC Reading".
3. Check if the "C1A24" is detected as the current malfunction in "Self Diagnostic Result" of "ICC/ADAS".

Is "C1A24" detected as the current malfunction?

- YES >> Refer to [CCS-135, "Diagnosis Procedure"](#).
NO >> Refer to [GI-50, "Intermittent Incident"](#).

Diagnosis Procedure

INFOID:0000000011132129

1. CHECK SELF-DIAGNOSIS RESULTS

Check if "U1000" is detected other than "C1A24" in "Self Diagnostic Result" of "ICC/ADAS".

Is "U1000" detected?

- YES >> Perform the CAN communication system inspection. Repair or replace the malfunctioning parts.
Refer to [CCS-165, "ADAS CONTROL UNIT : DTC Logic"](#).
NO >> GO TO 2.

2. CHECK TCM DATA MONITOR

Check that "SLCT LVR POSI" operates normally in "DATA MONITOR" of "TRANSMISSION".

Is the inspection result normal?

- YES >> Replace the ADAS control unit. Refer to [DAS-85, "Removal and Installation"](#).
NO >> GO TO 3.

3. PERFORM TCM SELF-DIAGNOSIS

1. Perform "All DTC Reading".
2. Check if any DTC is detected in "Self Diagnostic Result" of "TRANSMISSION".

Is any DTC detected?

A
B
C
D
E
F
G
H
I
J
K
L
M
N
P

CCS

C1A24 NP RANGE

< DTC/CIRCUIT DIAGNOSIS >

[ICC]

-
- YES >> Perform diagnosis on the detected DTC and repair or replace the malfunctioning parts. Refer to [TM-63, "DTC Index"](#) (RE0F10E) or [TM-277, "DTC Index"](#) (RE0F10J).
- NO >> Replace the ADAS control unit. Refer to [DAS-85, "Removal and Installation"](#).

C1A26 ECD MODE MALFUNCTION

< DTC/CIRCUIT DIAGNOSIS >

[ICC]

C1A26 ECD MODE MALFUNCTION

DTC Logic

INFOID:0000000011132130

DTC DETECTION LOGIC

DTC (On board display)	Trouble diagnosis name	DTC detecting condition	Possible cause
C1A26 (26)	ECD MODE MALF	If an abnormal condition occurs with ECD system	ABS actuator and electric unit (control unit)

NOTE:

If DTC "C1A26" is detected along with DTC "U1000", "U0415" or "U0121" first diagnose the DTC "U1000", "U0415" or "U0121".

- DTC "U1000": Refer to [CCS-165, "ADAS CONTROL UNIT : DTC Logic"](#).
- DTC "U0415": Refer to [CCS-161, "ADAS CONTROL UNIT : DTC Logic"](#).
- DTC "U0121": Refer to [CCS-153, "ADAS CONTROL UNIT : DTC Logic"](#).

DTC CONFIRMATION PROCEDURE

1. PERFORM DTC CONFIRMATION PROCEDURE

1. Start the engine.
2. Wait for approximately 1 minute after turning the MAIN switch of ICC system ON.
3. Perform "All DTC Reading" with CONSULT.
4. Check if the "C1A26" is detected as the current malfunction in "Self Diagnostic Result" of "ICC/ADAS".

Is "C1A26" detected as the current malfunction?

- YES >> Refer to [CCS-137, "Diagnosis Procedure"](#).
NO >> Refer to [GI-50, "Intermittent Incident"](#).

Diagnosis Procedure

INFOID:0000000011132131

1. CHECK SELF-DIAGNOSIS RESULTS

Check if "U1000", "U0415" or "U0121" is detected other than "C1A26" in "Self Diagnostic Result" of "ICC/ADAS".

Is any DTC detected?

- YES >> Perform diagnosis on the detected DTC and repair or replace the malfunctioning parts. Refer to [CCS-60, "DTC Index"](#).
NO >> GO TO 2.

2. PERFORM SELF-DIAGNOSIS OF ABS ACTUATOR AND ELECTRIC UNIT (CONTROL UNIT)

Check if any DTC is detected in "Self Diagnostic Result" of "ABS".

Is any DTC detected?

- YES >> Perform diagnosis on the detected DTC and repair or replace the malfunctioning parts. Refer to [BRC-46, "DTC Index"](#).
NO >> Replace ADAS control unit. Refer to [DAS-85, "Removal and Installation"](#).

A
B
C
D
E
F
G
H
I
J
K
L
M
N
P

CCS

C1A27 ECD POWER SUPPLY CIRCUIT

< DTC/CIRCUIT DIAGNOSIS >

[ICC]

C1A27 ECD POWER SUPPLY CIRCUIT

DTC Logic

INFOID:0000000011132132

DTC DETECTION LOGIC

DTC (On board display)	Trouble diagnosis name	DTC detecting condition	Possible cause
C1A27 (27)	ECD PWR SUPPLY CIR	ECD system power supply voltage is excessively low	<ul style="list-style-type: none">• ABS actuator and electric unit (control unit) power supply circuit• ABS actuator and electric unit (control unit)

NOTE:

If DTC "C1A27" is detected along with DTC "U1000", "U0415" or "U0121" first diagnose the DTC "U1000", "U0415" or "U0121".

- DTC "U1000": Refer to [CCS-165, "ADAS CONTROL UNIT : DTC Logic"](#).
- DTC "U0415": Refer to [CCS-161, "ADAS CONTROL UNIT : DTC Logic"](#).
- DTC "U0121": Refer to [CCS-153, "ADAS CONTROL UNIT : DTC Logic"](#).

DTC CONFIRMATION PROCEDURE

1. PERFORM DTC CONFIRMATION PROCEDURE

1. Start the engine.
2. Wait for approximately 1 minute after turning the MAIN switch of ICC system ON.
3. Perform "All DTC Reading" with CONSULT.
4. Check if the "C1A27" is detected as the current malfunction in "Self Diagnostic Result" of "ICC/ADAS".

Is "C1A27" detected as the current malfunction?

- YES >> Refer to [CCS-138, "Diagnosis Procedure"](#).
NO >> Refer to [GI-50, "Intermittent Incident"](#).

Diagnosis Procedure

INFOID:0000000011132133

1. CHECK SELF-DIAGNOSIS RESULTS

Check if "U1000", "U0415" or "U0121" is detected other than "C1A27" in "Self Diagnostic Result" of "ICC/ADAS".

Is any DTC detected?

- YES >> Perform diagnosis on the detected DTC and repair or replace the malfunctioning parts. Refer to [CCS-60, "DTC Index"](#).
NO >> GO TO 2.

2. CHECK POWER SUPPLY CIRCUIT OF ABS ACTUATOR AND ELECTRIC UNIT (CONTROL UNIT)

Check power supply circuit of ABS actuator and electric unit (control unit). Refer to [BRC-70, "Diagnosis Procedure"](#).

Is the inspection result normal?

- YES >> Perform self-diagnosis of ABS actuator and electric unit (control unit). Refer to [BRC-46, "DTC Index"](#).
NO >> Repair the harnesses or connectors.

C1A2A ICC SENSOR POWER SUPPLY CIRCUIT

< DTC/CIRCUIT DIAGNOSIS >

[ICC]

C1A2A ICC SENSOR POWER SUPPLY CIRCUIT

DTC Logic

INFOID:0000000011132134

DTC DETECTION LOGIC

DTC (On board display)	Trouble diagnosis name	DTC detecting condition	Possible cause
C1A2A (80)	ICC SEN PWR SUP CIR	Abnormal power supply voltage in ICC sensor	<ul style="list-style-type: none">• Harness, connector, fuse• ICC sensor

DTC CONFIRMATION PROCEDURE

1. PERFORM DTC CONFIRMATION PROCEDURE

1. Start the engine.
2. Turn the MAIN switch of ICC system ON.
3. Perform "All DTC Reading" with CONSULT.
4. Check if the "C1A2A" is detected as the current malfunction in "Self Diagnostic Result" of "ICC/ADAS".

Is "C1A2A" detected as the current malfunction?

- YES >> Refer to [CCS-139, "Diagnosis Procedure"](#).
NO >> Refer to [GI-50, "Intermittent Incident"](#).

Diagnosis Procedure

INFOID:0000000011132135

1. CHECK SELF-DIAGNOSIS RESULTS

Check if "U1000" is detected other than "C1A2A" in "Self Diagnostic Result" of "ICC/ADAS".

Is any DTC detected?

- YES >> Perform diagnosis on the detected DTC and repair or replace the malfunctioning parts. Refer to [CCS-165, "ADAS CONTROL UNIT : DTC Logic"](#).
NO >> GO TO 2.

2. CHECK ICC SENSOR SELF-DIAGNOSIS

Check if any DTC is detected in "Self Diagnostic Result" of "LASER/RADAR".

Is any DTC detected?

- YES >> Perform diagnosis on the detected DTC and repair or replace the malfunctioning parts. Refer to [CCS-66, "DTC Index"](#).
NO >> Replace ADAS control unit. Refer to [DAS-85, "Removal and Installation"](#).

A
B
C
D
E
F
G
H
I
J
K
L
M
N
P

CCS

C1A33 CAN TRANSMISSION ERROR

< DTC/CIRCUIT DIAGNOSIS >

[ICC]

C1A33 CAN TRANSMISSION ERROR

DTC Logic

INFOID:0000000011132136

DTC DETECTION LOGIC

DTC (On board display)	Trouble diagnosis name	DTC detecting condition	Possible causes
C1A33 (33)	CAN TRANSMISSION ERR	If an error occurs in the CAN communication signal that ADAS control unit transmits to ECM	ADAS control unit

NOTE:

If DTC "C1A33" is detected along with DTC "U1000", first diagnose the DTC "U1000". Refer to [CCS-165. "ADAS CONTROL UNIT : DTC Logic"](#).

DTC CONFIRMATION PROCEDURE

1. PERFORM DTC CONFIRMATION PROCEDURE

1. Start the engine.
2. Turn the MAIN switch of ICC system ON.
3. Perform "All DTC Reading" with CONSULT.
4. Check if the "C1A33" is detected as the current malfunction in "Self Diagnostic Result" of "ICC/ADAS".

Is "C1A33" detected as the current malfunction?

- YES >> Refer to [CCS-140. "Diagnosis Procedure"](#).
NO >> Refer to [GI-50. "Intermittent Incident"](#).

Diagnosis Procedure

INFOID:0000000011132137

1. CHECK SELF-DIAGNOSIS RESULTS

Check if "U1000" is detected other than "C1A33" in "Self Diagnostic Result" of "ICC/ADAS".

Is "U1000" detected?

- YES >> Perform the CAN communication system inspection. Repair or replace the malfunctioning parts.
Refer to [CCS-165. "ADAS CONTROL UNIT : DTC Logic"](#).
NO >> Replace the ADAS control unit. Refer to [DAS-85. "Removal and Installation"](#).

C1A34 COMMAND ERROR

< DTC/CIRCUIT DIAGNOSIS >

[ICC]

C1A34 COMMAND ERROR

DTC Logic

INFOID:000000011132138

DTC DETECTION LOGIC

DTC (On board display)	Trouble diagnosis name	DTC detecting condition	Possible causes
C1A34 (34)	COMMAND ERROR	If an error occurs in the command signal that ADAS control unit transmits to ECM via CAN communication	ADAS control unit

NOTE:

If DTC "C1A34" is detected along with DTC "U1000", first diagnose the DTC "U1000". Refer to [CCS-165, "ADAS CONTROL UNIT : DTC Logic"](#).

DTC CONFIRMATION PROCEDURE

1. PERFORM DTC CONFIRMATION PROCEDURE

1. Start the engine.
2. Operate the ICC system and drive.
CAUTION:
Always drive safely.
3. Stop the vehicle.
4. Perform "All DTC Reading" with CONSULT.
5. Check if the "C1A34" is detected as the current malfunction in "Self Diagnostic Result" of "ICC/ADAS".

Is "C1A34" detected as the current malfunction?

- YES >> Refer to [CCS-141, "Diagnosis Procedure"](#).
NO >> Refer to [GI-50, "Intermittent Incident"](#).

Diagnosis Procedure

INFOID:000000011132139

1. CHECK SELF-DIAGNOSIS RESULTS

Check if "U1000" is detected other than "C1A34" in "Self Diagnostic Result" of "ICC/ADAS".

Is "U1000" detected?

- YES >> Perform the CAN communication system inspection. Repair or replace the malfunctioning parts.
Refer to [CCS-165, "ADAS CONTROL UNIT : DTC Logic"](#).
NO >> Replace the ADAS control unit. Refer to [DAS-85, "Removal and Installation"](#).

C1A35 ACCELERATOR PEDAL ACTUATOR

< DTC/CIRCUIT DIAGNOSIS >

[ICC]

C1A35 ACCELERATOR PEDAL ACTUATOR

DTC Logic

INFOID:0000000011132140

DTC DETECTION LOGIC

DTC (On board display)	Trouble diagnosis name	DTC detecting condition	Possible causes
C1A35 (35)	APA CIR	If the accelerator pedal actuator is malfunctioning	Accelerator pedal actuator

NOTE:

If DTC "C1A35" is detected along with DTC "U1000", first diagnose the DTC "U1000". Refer to [CCS-165, "ADAS CONTROL UNIT : DTC Logic"](#).

Diagnosis Procedure

INFOID:0000000011132141

1. PERFORM DTC CONFIRMATION PROCEDURE

1. Start the engine.
2. Turn the DCA system ON.
3. Perform "All DTC Reading" with CONSULT.
4. Check if the "C1A35" is detected as the current malfunction in self-diagnosis results of "ICC/ADAS".

Is "C1A35" detected as the current malfunction?

- YES >> GO TO 2.
NO >> INSPECTION END

2. CHECK SELF-DIAGNOSIS RESULTS

Check if "U1000" is detected other than "C1A35" in "Self Diagnostic Result" of "ICC/ADAS".

Is "U1000" detected?

- YES >> Perform the CAN communication system inspection. Repair or replace the malfunctioning parts.
Refer to [CCS-165, "ADAS CONTROL UNIT : DTC Logic"](#).
NO >> GO TO 3.

3. CHECK ACCELERATOR PEDAL ACTUATOR SELF-DIAGNOSIS RESULTS

Check if the DTC is detected in "Self Diagnostic Result" of "ACCELE PEDAL ACT".

Is any DTC detected?

- YES >> Perform diagnosis on the detected DTC and repair or replace the malfunctioning parts. Refer to [DAS-48, "DTC Index"](#).
NO >> Replace the ADAS control unit. Refer to [DAS-85, "Removal and Installation"](#).

C1A36 ACCELERATOR PEDAL ACTUATOR CAN COMM

< DTC/CIRCUIT DIAGNOSIS >

[ICC]

C1A36 ACCELERATOR PEDAL ACTUATOR CAN COMM

DTC Logic

INFOID:0000000011132142

DTC DETECTION LOGIC

DTC (On board display)	Trouble diagnosis name	DTC detecting condition	Possible causes
C1A36 (36)	APA CAN COMM CIR	If an error occurs in the signal that the accelerator pedal actuator transmits via ITS communication	<ul style="list-style-type: none">• ADAS control unit• Accelerator pedal actuator• ITS communication system

NOTE:

If DTC "C1A36" is detected along with DTC "U1000", first diagnose the DTC "U1000". Refer to [CCS-165, "ADAS CONTROL UNIT : DTC Logic"](#).

DTC CONFIRMATION PROCEDURE

1. PERFORM DTC CONFIRMATION PROCEDURE

1. Start the engine.
2. Turn the DCA system ON.
3. Perform "All DTC Reading" with CONSULT.
4. Check if the "C1A36" is detected as the current malfunction in self-diagnosis results of "ICC/ADAS".

Is "C1A36" detected as the current malfunction?

- YES >> Refer to [CCS-143, "Diagnosis Procedure"](#).
NO >> Refer to [GI-50, "Intermittent Incident"](#).

Diagnosis Procedure

INFOID:0000000011132143

1. CHECK ADAS CONTROL UNIT SELF-DIAGNOSIS RESULTS

Check if "U1000" is detected other than "C1A36" in "Self Diagnostic Result" of "ICC/ADAS".

Is "U1000" detected?

- YES >> Perform the CAN communication system inspection. Repair or replace the malfunctioning parts. Refer to [CCS-165, "ADAS CONTROL UNIT : DTC Logic"](#).
NO >> GO TO 2.

2. CHECK ACCELERATOR PEDAL ACTUATOR SELF-DIAGNOSIS RESULTS

Check if the DTC is detected in "Self Diagnostic Result" of "ACCELE PEDAL ACT".

Is any DTC detected?

- YES >> Perform diagnosis on the detected DTC and repair or replace the malfunctioning parts. Refer to [DAS-48, "DTC Index"](#).
NO >> Replace the ADAS control unit. Refer to [DAS-85, "Removal and Installation"](#).

A
B
C
D
E
F
G
H
I
J
K
L
M
N
P

CCS

C1A37 ACCELERATOR PEDAL ACTUATOR CAN 2

< DTC/CIRCUIT DIAGNOSIS >

[ICC]

C1A37 ACCELERATOR PEDAL ACTUATOR CAN 2

DTC Logic

INFOID:0000000011132144

DTC DETECTION LOGIC

DTC (On board display)	Trouble diagnosis name	DTC detecting condition	Possible causes
C1A37 (133)	APA CAN CIR2	If ADAS control unit detects an error signal that is received from accelerator pedal actuator via ITS communication	Accelerator pedal actuator malfunction

NOTE:

If DTC "C1A37" is detected along with DTC "U1000", first diagnose the DTC "U1000". Refer to [CCS-165, "ADAS CONTROL UNIT : DTC Logic"](#).

DTC CONFIRMATION PROCEDURE

1. PERFORM DTC CONFIRMATION PROCEDURE

1. Start the engine.
2. Turn the DCA system ON.
3. Perform "All DTC Reading" with CONSULT.
4. Check if the "C1A37" is detected as the current malfunction in self-diagnosis results of "ICC/ADAS".

Is "C1A37" detected as the current malfunction?

- YES >> Refer to [CCS-144, "Diagnosis Procedure"](#).
NO >> Refer to [GI-50, "Intermittent Incident"](#).

Diagnosis Procedure

INFOID:0000000011132145

1. CHECK ADAS CONTROL UNIT SELF-DIAGNOSIS RESULTS

Check if "U1000" is detected other than "C1A37" in "Self Diagnostic Result" of "ICC/ADAS".

Is "U1000" detected?

- YES >> Perform the CAN communication system inspection. Repair or replace the malfunctioning parts.
Refer to [CCS-165, "ADAS CONTROL UNIT : DTC Logic"](#).
NO >> GO TO 2.

2. REPLACE ACCELERATOR PEDAL ASSEMBLY

1. Turn the ignition switch OFF.
2. Replace the accelerator pedal assembly.
3. Turn the ignition switch ON.
4. Erases all self-diagnosis results.
5. Perform "All DTC Reading" again.
6. Check if the DTC "C1A37" is detected in self-diagnosis results of "ICC/ADAS".

Is "C1A37" detected?

- YES >> Replace the ADAS control unit. Refer to [DAS-85, "Removal and Installation"](#).
NO >> INSPECTION END

C1A38 ACCELERATOR PEDAL ACTUATOR CAN 1

< DTC/CIRCUIT DIAGNOSIS >

[ICC]

C1A38 ACCELERATOR PEDAL ACTUATOR CAN 1

DTC Logic

INFOID:0000000011132146

DTC DETECTION LOGIC

DTC (On board display)	Trouble diagnosis name	DTC detecting condition	Possible causes
C1A38 (132)	APA CAN CIR1	If ADAS control unit detects an error signal that is received from accelerator pedal actuator via ITS communication	Accelerator pedal actuator malfunction

NOTE:

If DTC "C1A38" is detected along with DTC "U1000", first diagnose the DTC "U1000". Refer to [CCS-165, "ADAS CONTROL UNIT : DTC Logic"](#).

DTC CONFIRMATION PROCEDURE

1. PERFORM DTC CONFIRMATION PROCEDURE

1. Start the engine.
2. Turn the DCA system ON.
3. Perform "All DTC Reading" with CONSULT.
4. Check if the "C1A38" is detected as the current malfunction in self-diagnosis results of "ICC/ADAS".

Is "C1A38" detected as the current malfunction?

- YES >> Refer to [CCS-145, "Diagnosis Procedure"](#).
NO >> Refer to [GI-50, "Intermittent Incident"](#).

Diagnosis Procedure

INFOID:0000000011132147

1. CHECK ADAS CONTROL UNIT SELF-DIAGNOSIS RESULTS

Check if "U1000" is detected other than "C1A38" in "Self Diagnostic Result" of "ICC/ADAS".

Is "U1000" detected?

- YES >> Perform the CAN communication system inspection. Repair or replace the malfunctioning parts.
Refer to [CCS-165, "ADAS CONTROL UNIT : DTC Logic"](#).
NO >> GO TO 2.

2. REPLACE ACCELERATOR PEDAL ASSEMBLY

1. Turn the ignition switch OFF.
2. Replace the accelerator pedal assembly.
3. Erases All self-diagnosis results.
4. Perform "All DTC Reading" again.
5. Check if the "C1A38" is detected in self-diagnosis results of "ICC/ADAS".

Is "C1A38" detected?

- YES >> Replace the ADAS control unit. Refer to [DAS-85, "Removal and Installation"](#).
NO >> INSPECTION END

CCS

C1A39 STEERING ANGLE SENSOR

< DTC/CIRCUIT DIAGNOSIS >

[ICC]

C1A39 STEERING ANGLE SENSOR

DTC Logic

INFOID:000000011132148

DTC DETECTION LOGIC

DTC (On board display)	Trouble diagnosis name	DTC detecting condition	Possible causes
C1A39 (39)	STRG SEN CIR	If the steering angle sensor is malfunction	Steering angle sensor

NOTE:

If DTC "C1A39" is detected along with DTC "U1000", first diagnose the DTC "U1000". Refer to [CCS-165, "ADAS CONTROL UNIT : DTC Logic"](#).

DTC CONFIRMATION PROCEDURE

1. PERFORM DTC CONFIRMATION PROCEDURE

1. Start the engine.
2. Turn the DCA system ON.
3. Perform "All DTC Reading" with CONSULT.
4. Check if the "C1A39" is detected as the current malfunction in self-diagnosis results of "ICC/ADAS".

Is "C1A39" detected as the current malfunction?

- YES >> Refer to [CCS-146, "Diagnosis Procedure"](#).
NO >> Refer to [GI-50, "Intermittent Incident"](#).

Diagnosis Procedure

INFOID:000000011132149

1. CHECK SELF-DIAGNOSIS RESULTS

Check if "U1000" is detected other than "C1A39" in "Self Diagnostic Result" of "ICC/ADAS".

Is "U1000" detected?

- YES >> Perform the CAN communication system inspection. Repair or replace the malfunctioning parts. Refer to [DAS-222, "ADAS CONTROL UNIT : DTC Logic"](#).
NO >> GO TO 2.

2. CHECK ABS ACTUATOR AND ELECTRIC UNIT (CONTROL UNIT) SELF-DIAGNOSIS RESULTS

Check if any DTC is detected in "Self Diagnostic Result" of "ABS".

Is any DTC detected?

- YES >> Perform diagnosis on the detected DTC and repair or replace the malfunctioning parts. Refer to [BRC-46, "DTC Index"](#).
NO >> 1. Perform neutral position adjustment of steering angle sensor. Refer to [BRC-60, "Work Procedure"](#).
2. GO TO 3.

3. CHECK ADAS CONTROL UNIT SELF-DIAGNOSIS RESULTS

Check if "C1A39" is detected as the current malfunction in "Self Diagnostic Result" of "ICC/ADAS".

Is "C1A39" detected?

- YES >> Replace the ADAS control unit. Refer to [DAS-85, "Removal and Installation"](#).
NO >> Inspection End.

C1A50 ADAS CONTROL UNIT

< DTC/CIRCUIT DIAGNOSIS >

[ICC]

C1A50 ADAS CONTROL UNIT

DTC Logic

INFOID:0000000011132150

DTC DETECTION LOGIC

DTC	Trouble diagnosis name	DTC detecting condition	Possible cause
C1A50	ADAS MALFUNCTION	If ADAS control unit is malfunctioning	ADAS control unit

NOTE:

If DTC "C1A50" is detected along with DTC "U1000", first diagnose the DTC "U1000". Refer to [CCS-165. "ICC SENSOR : DTC Logic"](#).

1.PERFORM DTC CONFIRMATION PROCEDURE

1. Start the engine.
2. Turn the MAIN switch of ICC system ON.
3. Perform "All DTC Reading" with CONSULT.
4. Check if the "C1A50" is detected as the current malfunction in "Self Diagnostic Result" of "LASER/RADAR".

Is "C1A50" detected as the current malfunction?

- YES >> Refer to [CCS-147. "Diagnosis Procedure"](#).
NO >> Refer to [GI-50. "Intermittent Incident"](#).

Diagnosis Procedure

INFOID:0000000011132151

1.CHECK ICC SENSOR SELF-DIAGNOSIS RESULTS

Check if "U1000" is detected other than "C1A50" in "Self Diagnostic Result" of "LASER/RADAR".

Is "U1000" detected?

- YES >> Perform the CAN communication system inspection. Repair or replace the malfunctioning parts.
Refer to [CCS-165. "ICC SENSOR : DTC Logic"](#).
NO >> GO TO 2.

2.CHECK ADAS CONTROL UNIT SELF-DIAGNOSIS RESULTS

Check if any DTC is detected in "Self Diagnostic Result" of "ICC/ADAS".

Is any DTC detected?

- YES >> Perform diagnosis on the detected DTC and repair or replace the malfunctioning parts. Refer to [CCS-60. "DTC Index"](#).
NO >> Replace the ICC sensor. Refer to [CCS-195. "Removal and Installation"](#).

A
B
C
D
E
F
G
H
I
J
K
L
M
N
P



C1F01 ACCELERATOR PEDAL ACTUATOR

< DTC/CIRCUIT DIAGNOSIS >

[ICC]

C1F01 ACCELERATOR PEDAL ACTUATOR

DTC Logic

INFOID:0000000011132152

DTC DETECTION LOGIC

DTC (On board display)	Trouble diagnosis name	DTC detecting condition	Possible causes
C1F01 (91)	APA MOTOR MALF	If the accelerator pedal actuator motor error is detected	Accelerator pedal actuator integrated motor malfunction

DTC CONFIRMATION PROCEDURE

1. PERFORM DTC CONFIRMATION PROCEDURE

1. Turn the ignition switch OFF.
2. Turn the ignition switch ON.
3. Slowly depress the accelerator pedal completely, and then release it.
4. Repeat step 3 several times.
5. Perform "All DTC Reading" with CONSULT.
6. Check if the DTC "C1F01" is detected as the current malfunction on the self-diagnosis results of "ICC/ADAS".

Is "C1F01" detected as the current malfunction?

- YES >> Refer to [CCS-148, "Diagnosis Procedure"](#).
NO >> Refer to [GI-50, "Intermittent Incident"](#).

Diagnosis Procedure

INFOID:0000000011132153

1. CHECK ADAS CONTROL UNIT SELF-DIAGNOSIS RESULTS

Check if "U1000" is detected other than "C1F01" in "Self Diagnostic Result" of "ICC/ADAS".

Is "U1000" detected?

- YES >> Perform the CAN communication system inspection. Repair or replace the malfunctioning parts.
Refer to [CCS-165, "ADAS CONTROL UNIT : DTC Logic"](#).
NO >> GO TO 2.

2. CHECK ACCELERATOR PEDAL ACTUATOR SELF-DIAGNOSIS RESULTS

Check if "C1F01" is detected in "Self Diagnostic Result" of "ACCELE PEDAL ACT".

Is "C1F01" detected?

- YES >> Refer to [DAS-48, "DTC Index"](#).
NO >> Replace the ADAS control unit. Refer to [DAS-85, "Removal and Installation"](#).

C1F02 ACCELERATOR PEDAL ACTUATOR

< DTC/CIRCUIT DIAGNOSIS >

[ICC]

C1F02 ACCELERATOR PEDAL ACTUATOR

DTC Logic

INFOID:0000000011132154

DTC DETECTION LOGIC

DTC (On board display)	Trouble diagnosis name	DTC detecting condition	Possible causes
C1F02 (92)	APA C/U MALF	If the accelerator pedal actuator integrated control unit error is detected	Accelerator pedal actuator integrated control unit malfunction

1.PERFORM DTC CONFIRMATION PROCEDURE

1. Start the engine.
2. Turn the DCA system ON.
3. Perform "All DTC Reading" with CONSULT.
4. Check if the "C1F02" is detected as the current malfunction on the self-diagnosis results of "ICC/ADAS".

Is "C1F02" detected as the current malfunction?

- YES >> Refer to [CCS-149, "Diagnosis Procedure"](#).
NO >> Refer to [GI-50, "Intermittent Incident"](#).

Diagnosis Procedure

INFOID:0000000011132155

1.CHECK ADAS CONTROL UNIT SELF-DIAGNOSIS RESULTS

Check if "U1000" is detected other than "C1F02" in "Self Diagnostic Result" of "ICC/ADAS".

Is "U1000" detected?

- YES >> Perform the CAN communication system inspection. Repair or replace the malfunctioning parts.
Refer to [CCS-165, "ADAS CONTROL UNIT : DTC Logic"](#).
NO >> GO TO 2.

2.CHECK ACCELERATOR PEDAL ACTUATOR SELF-DIAGNOSIS RESULTS

Check if "C1F02" is detected in "Self Diagnostic Result" of "ACCELE PEDAL ACT".

Is "C1F02" detected?

- YES >> Refer to [DAS-48, "DTC Index"](#).
NO >> Replace the ADAS control unit. Refer to [DAS-85, "Removal and Installation"](#).

A
B
C
D
E
F
G
H
I
J
K
L
M
N
P



C1F05 ACCELERATOR PEDAL ACTUATOR POWER SUPPLY CIRCUIT

< DTC/CIRCUIT DIAGNOSIS >

[ICC]

C1F05 ACCELERATOR PEDAL ACTUATOR POWER SUPPLY CIRCUIT

DTC Logic

INFOID:000000011132156

DTC DETECTION LOGIC

DTC (On board display)	Trouble diagnosis name	DTC detecting condition	Possible causes
C1F05 (95)	APA PWR SUPPLY CIR	The battery voltage sent to accelerator pedal actuator remains less than 7.9 V or more than 19.3 V for 5 seconds	<ul style="list-style-type: none">• Harness, connector, or fuse• Accelerator pedal actuator

DTC CONFIRMATION PROCEDURE

1. PERFORM DTC CONFIRMATION PROCEDURE

1. Start the engine.
2. Turn the DCA system ON.
3. Perform "All DTC Reading" with CONSULT.
4. Check if the "C1F05" is detected as the current malfunction on the self-diagnosis results of "ICC/ADAS".

Is "C1F05" detected as the current malfunction?

- YES >> Refer to [CCS-150, "Diagnosis Procedure"](#).
NO >> Refer to [GI-50, "Intermittent Incident"](#).

Diagnosis Procedure

INFOID:000000011132157

1. CHECK ADAS CONTROL UNIT SELF-DIAGNOSIS RESULTS

Check if "U1000" is detected other than "C1F05" in "Self Diagnostic Result" of "ICC/ADAS".

Is "U1000" detected?

- YES >> Perform the CAN communication system inspection. Repair or replace the malfunctioning parts.
Refer to [CCS-165, "ADAS CONTROL UNIT : DTC Logic"](#).
NO >> GO TO 2.

2. CHECK ACCELERATOR PEDAL ACTUATOR SELF-DIAGNOSIS RESULTS

Check if "C1F05" is detected in "Self Diagnostic Result" of "ACCELE PEDAL ACT".

Is "C1F05" detected?

- YES >> Refer to [DAS-48, "DTC Index"](#).
NO >> Replace the ADAS control unit. Refer to [DAS-85, "Removal and Installation"](#).

C10B7 YAW RATE SENSOR

< DTC/CIRCUIT DIAGNOSIS >

[ICC]

C10B7 YAW RATE SENSOR

DTC Logic

INFOID:0000000011132158

DTC DETECTION LOGIC

DTC	Trouble diagnosis name	DTC detecting condition	Possible causes
C10B7	YAW RATE SENSOR	The yaw rate/side/decel G sensor calibration is incorrect	<ul style="list-style-type: none">The calibration of yaw rate/side/decel G sensor is not yet performedInterruption in yaw rate/side/decel G sensor calibration

DTC CONFIRMATION PROCEDURE

1. PERFORM DTC CONFIRMATION PROCEDURE

1. Start the engine.
2. Turn the MAIN switch of ICC system ON.
3. Perform "All DTC Reading" with CONSULT.
4. Check if the "C10B7" is detected as the current malfunction in "Self Diagnostic Result" of "LASER/RADAR".

Is "C10B7" detected as the current malfunction?

- YES >> Refer to [CCS-151, "Diagnosis Procedure"](#).
NO >> INSPECTION END

Diagnosis Procedure

INFOID:0000000011132159

1. PERFORM CALIBRATION OF THE YAW RATE/SIDE/DECEL G SENSOR

1. Perform calibration of the yaw rate/side/decel G sensor. Refer to [BRC-62, "Work Procedure"](#).
2. Erase All self-diagnosis results with CONSULT.
3. Perform "All DTC Reading".
4. Check if the "C10B7" is detected in "Self Diagnostic Result" of "LASER/RADAR".

Is "C10B7" detected?

- YES >> Replace the ICC sensor. Refer to [CCS-195, "Removal and Installation"](#).
NO >> INSPECTION END

A
B
C
D
E
F
G
H
I
J
K
L
M
N
P



U0104 ADAS CAN 1

< DTC/CIRCUIT DIAGNOSIS >

[ICC]

U0104 ADAS CAN 1

DTC Logic

INFOID:0000000011132160

DTC DETECTION LOGIC

DTC	Trouble diagnosis name	DTC detecting condition	Possible causes
U0104	ADAS CAN CIR 1	If ICC sensor detects an error signal that is received from ADAS control unit via ITS communication	ADAS control unit

NOTE:

If DTC "U0104" is detected along with DTC "U1000", first diagnose the DTC "U1000". Refer to [CCS-165, "ICC SENSOR : DTC Logic"](#).

DTC CONFIRMATION PROCEDURE

1. PERFORM DTC CONFIRMATION PROCEDURE

1. Start the engine.
2. Turn the MAIN switch of ICC system ON.
3. Perform "All DTC Reading" with CONSULT.
4. Check if the "U0104" is detected as the current malfunction in "Self Diagnostic Result" of "LASER/RADAR".

Is "U0104" detected as the current malfunction?

- YES >> Refer to [CCS-152, "Diagnosis Procedure"](#).
NO >> Refer to [GI-50, "Intermittent Incident"](#).

Diagnosis Procedure

INFOID:0000000011132161

1. CHECK ICC SENSOR SELF-DIAGNOSIS RESULTS

Check if "U1000" is detected other than "U0104" in "Self Diagnostic Result" of "LASER/RADAR".

Is "U1000" detected?

- YES >> Perform the CAN communication system inspection. Repair or replace the malfunctioning parts.
Refer to [CCS-165, "ICC SENSOR : DTC Logic"](#).
NO >> GO TO 2.

2. CHECK ADAS CONTROL UNIT SELF-DIAGNOSIS RESULTS

Check if any DTC is detected in "Self Diagnostic Result" of "ICC/ADAS".

Is any DTC detected?

- YES >> Perform diagnosis on the detected DTC and repair or replace the malfunctioning parts. Refer to [CCS-60, "DTC Index"](#).
NO >> Replace the ICC sensor. Refer to [CCS-195, "Removal and Installation"](#).

U0121 VDC CAN 2

< DTC/CIRCUIT DIAGNOSIS >

[ICC]

U0121 VDC CAN 2 ADAS CONTROL UNIT

ADAS CONTROL UNIT : DTC Logic

INFOID:0000000011132162

DTC DETECTION LOGIC

DTC (On board display)	Trouble diagnosis name	DTC detecting condition	Possible causes
U0121 (127)	VDC CAN CIR2	If ADAS control unit detects an error signal that is received from ABS actuator and electric unit (control unit) via CAN communication	ABS actuator and electric unit (control unit)

NOTE:

If DTC "U0121" is detected along with DTC "U1000", first diagnose the DTC "U1000". Refer to [CCS-165, "ADAS CONTROL UNIT : DTC Logic"](#).

DTC CONFIRMATION PROCEDURE

1. PERFORM DTC CONFIRMATION PROCEDURE

1. Start the engine.
2. Turn the MAIN switch of ICC system ON.
3. Perform "All DTC Reading" with CONSULT.
4. Check if the "U0121" is detected as the current malfunction in "Self Diagnostic Result" of "ICC/ADAS".

Is "U0121" detected as the current malfunction?

- YES >> Refer to [CCS-153, "ADAS CONTROL UNIT : Diagnosis Procedure"](#).
 NO >> Refer to [GI-50, "Intermittent Incident"](#).

ADAS CONTROL UNIT : Diagnosis Procedure

INFOID:0000000011132163

1. CHECK SELF-DIAGNOSIS RESULTS

Check if "U1000" is detected other than "U0121" in "Self Diagnostic Result" of "ICC/ADAS".

Is "U1000" detected?

- YES >> Perform the CAN communication system inspection. Repair or replace the malfunctioning parts. Refer to [CCS-165, "ADAS CONTROL UNIT : DTC Logic"](#).
 NO >> GO TO 2.

2. CHECK ABS ACTUATOR AND ELECTRIC UNIT (CONTROL UNIT) SELF-DIAGNOSIS RESULTS

Check if any DTC is detected in "Self Diagnostic Result" of "ABS".

Is any DTC detected?

- YES >> Perform diagnosis on the detected DTC and repair or replace the malfunctioning parts. Refer to [BRC-46, "DTC Index"](#).
 NO >> Replace the ADAS control unit. Refer to [DAS-85, "Removal and Installation"](#).

ICC SENSOR

ICC SENSOR : DTC Logic

INFOID:0000000011132164

DTC DETECTION LOGIC

DTC	Trouble diagnosis name	DTC detecting condition	Possible causes
U0121	VDC CAN CIR2	If ICC sensor detects an error signal that is received from ABS actuator and electric unit (control unit) via ADAS control unit	ABS actuator and electric unit (control unit)

NOTE:

If DTC "U0121" is detected along with DTC "U1000", first diagnose the DTC "U1000". Refer to [CCS-165, "ICC SENSOR : DTC Logic"](#).

A
B
C
D
E
F
G
H
I
J
K
L
M
N



P

< DTC/CIRCUIT DIAGNOSIS >

DTC CONFIRMATION PROCEDURE

1.PERFORM DTC CONFIRMATION PROCEDURE

1. Start the engine.
2. Turn the MAIN switch of ICC system ON.
3. Perform "All DTC Reading" with CONSULT.
4. Check if the "U0121" is detected as the current malfunction in "Self Diagnostic Result" of "LASER/RADAR".

Is "U0121" detected as the current malfunction?

YES >> Refer to [CCS-154, "ICC SENSOR : Diagnosis Procedure"](#).

NO >> Refer to [GI-50, "Intermittent Incident"](#).

ICC SENSOR : Diagnosis Procedure

INFOID:000000011132165

1.CHECK ICC SENSOR SELF-DIAGNOSIS RESULTS

Check if "U1000" is detected other than "U0121" in "Self Diagnostic Result" of "LASER/RADAR".

Is "U1000" detected?

YES >> Perform the CAN communication system inspection. Repair or replace the malfunctioning parts.
Refer to [CCS-165, "ICC SENSOR : DTC Logic"](#).

NO >> GO TO 2.

2.CHECK ADAS CONTROL UNIT SELF-DIAGNOSIS RESULTS

Check if any DTC is detected in "Self Diagnostic Result" of "ICC/ADAS".

Is any DTC detected?

YES >> Perform diagnosis on the detected DTC and repair or replace the malfunctioning parts. Refer to [CCS-165, "ADAS CONTROL UNIT : DTC Logic"](#).

NO >> Replace the ICC sensor. Refer to [CCS-195, "Removal and Installation"](#).

U0126 STRG SEN CAN 1 ADAS CONTROL UNIT

ADAS CONTROL UNIT : DTC Logic

INFOID:0000000011132166

DTC DETECTION LOGIC

DTC (On board display)	Trouble diagnosis name	DTC detecting condition	Possible causes
U0126 (130)	STRG SEN CAN CIR1	If ADAS control unit detects an error signal that is received from steering angle sensor via CAN communication	Steering angle sensor

NOTE:

If DTC "U0126" is detected along with DTC "U1000", first diagnose the DTC "U1000". Refer to [CCS-165, "ADAS CONTROL UNIT : DTC Logic"](#).

DTC CONFIRMATION PROCEDURE

1. PERFORM DTC CONFIRMATION PROCEDURE

1. Start the engine.
2. Turn the MAIN switch of ICC system ON.
3. Perform "All DTC Reading" with CONSULT.
4. Check if the "U0126" is detected as the current malfunction in "Self Diagnostic Result" of "ICC/ADAS".

Is "U0126" detected as the current malfunction?

- YES >> Refer to [CCS-155, "ADAS CONTROL UNIT : Diagnosis Procedure"](#).
 NO >> Refer to [GI-50, "Intermittent Incident"](#).

ADAS CONTROL UNIT : Diagnosis Procedure

INFOID:0000000011132167

1. CHECK SELF-DIAGNOSIS RESULTS

Check if "U1000" is detected other than "U0126" in "Self Diagnostic Result" of "ICC/ADAS".

Is "U1000" detected?

- YES >> Perform the CAN communication system inspection. Repair or replace the malfunctioning parts. Refer to [CCS-165, "ADAS CONTROL UNIT : DTC Logic"](#).
 NO >> GO TO 2.

2. CHECK ABS ACTUATOR AND ELECTRIC UNIT (CONTROL UNIT) SELF-DIAGNOSIS RESULTS

Check if any DTC is detected in "Self Diagnostic Result" of "ABS".

Is any DTC detected?

- YES >> Perform diagnosis on the detected DTC and repair or replace the malfunctioning parts. Refer to [BRC-46, "DTC Index"](#).
 NO >> Replace the ADAS control unit. Refer to [DAS-85, "Removal and Installation"](#).

ICC SENSOR

ICC SENSOR : DTC Logic

INFOID:0000000011132168

DTC DETECTION LOGIC

DTC	Trouble diagnosis name	DTC detecting condition	Possible causes
U0126	STRG SEN CAN CIR1	If ICC sensor detects an error signal that is received from steering angle sensor via ADAS control unit	Steering angle sensor

NOTE:

If DTC "U0126" is detected along with DTC "U1000", first diagnose the DTC "U1000". Refer to [CCS-165, "ICC SENSOR : DTC Logic"](#).



< DTC/CIRCUIT DIAGNOSIS >

DTC CONFIRMATION PROCEDURE

1. PERFORM DTC CONFIRMATION PROCEDURE

1. Start the engine.
2. Turn the MAIN switch of ICC system ON.
3. Perform "All DTC Reading" with CONSULT.
4. Check if the "U0126" is detected as the current malfunction in "Self Diagnostic Result" of "LASER/RADAR".

Is "U0126" detected as the current malfunction?

YES >> Refer to [CCS-156, "ICC SENSOR : Diagnosis Procedure"](#).

NO >> Refer to [GI-50, "Intermittent Incident"](#).

ICC SENSOR : Diagnosis Procedure

INFOID:000000011132169

1. CHECK ICC SENSOR SELF-DIAGNOSIS RESULTS

Check if "U1000" is detected other than "U0126" in "Self Diagnostic Result" of "LASER/RADAR".

Is "U1000" detected?

YES >> Perform the CAN communication system inspection. Repair or replace the malfunctioning parts.
Refer to [CCS-165, "ICC SENSOR : DTC Logic"](#).

NO >> GO TO 2.

2. CHECK ADAS CONTROL UNIT SELF-DIAGNOSIS RESULTS

Check if any DTC is detected in "Self Diagnostic Result" of "ICC/ADAS".

Is any DTC detected?

YES >> Perform diagnosis on the detected DTC and repair or replace the malfunctioning parts. Refer to [CCS-60, "DTC Index"](#).

NO >> Replace the ICC sensor. Refer to [CCS-195, "Removal and Installation"](#).

U0235 ICC SENSOR CAN 1

< DTC/CIRCUIT DIAGNOSIS >

[ICC]

U0235 ICC SENSOR CAN 1

DTC Logic

INFOID:0000000011132170

DTC DETECTION LOGIC

DTC (On board display)	Trouble diagnosis name	DTC detecting condition	Possible causes
U0235 (144)	ICC SENSOR CAN CIR1	If ADAS control unit detects an error signal that is received from ICC sensor via ITS communication	ICC sensor

NOTE:

If DTC "U0235" is detected along with DTC "U1000", first diagnose the DTC "U1000". Refer to [CCS-165, "ICC SENSOR : DTC Logic"](#).

DTC CONFIRMATION PROCEDURE

1. PERFORM DTC CONFIRMATION PROCEDURE

1. Start the engine.
2. Turn the MAIN switch of ICC system ON.
3. Perform "All DTC Reading" with CONSULT.
4. Check if the "U0235" is detected as the current malfunction in "Self Diagnostic Result" of "ICC/ADAS".

Is "U0235" detected as the current malfunction?

- YES >> Refer to [CCS-157, "Diagnosis Procedure"](#).
NO >> Refer to [GI-50, "Intermittent Incident"](#).

Diagnosis Procedure

INFOID:0000000011132171

1. CHECK ADAS CONTROL UNIT SELF-DIAGNOSIS RESULTS

Check if "U1000" is detected other than "U0235" in "Self Diagnostic Result" of "ICC/ADAS".

Is "U1000" detected?

- YES >> Perform the CAN communication system inspection. Repair or replace the malfunctioning parts. Refer to [CCS-165, "ADAS CONTROL UNIT : DTC Logic"](#).
NO >> GO TO 2.

2. CHECK ICC SENSOR SELF-DIAGNOSIS RESULTS

Check if any DTC is detected in "Self Diagnostic Result" of "LASER/RADAR".

Is any DTC detected?

- YES >> Perform diagnosis on the detected DTC and repair or replace the malfunctioning parts. Refer to [CCS-66, "DTC Index"](#).
NO >> Replace the ADAS control unit. Refer to [DAS-85, "Removal and Installation"](#).

A
B
C
D
E
F
G
H
I
J
K
L
M
N
P

CCS

U0401 ECM CAN 1

< DTC/CIRCUIT DIAGNOSIS >

[ICC]

U0401 ECM CAN 1

DTC Logic

INFOID:0000000011132172

DTC DETECTION LOGIC

DTC (On board display)	Trouble diagnosis name	DTC detecting condition	Possible causes
U0401 (120)	ECM CAN CIR1	If ADAS control unit detects an error signal that is received from ECM via CAN communication	ECM

NOTE:

If DTC "U0401" is detected along with DTC "U1000", first diagnose the DTC "U1000". Refer to [CCS-165, "ADAS CONTROL UNIT : DTC Logic"](#).

DTC CONFIRMATION PROCEDURE

1. PERFORM DTC CONFIRMATION PROCEDURE

1. Start the engine.
2. Turn the MAIN switch of ICC system ON.
3. Perform "All DTC Reading" with CONSULT.
4. Check if the "U0401" is detected as the current malfunction in "Self Diagnostic Result" of "ICC/ADAS".

Is "U0401" detected as the current malfunction?

- YES >> Refer to [CCS-158, "Diagnosis Procedure"](#).
NO >> Refer to [GI-50, "Intermittent Incident"](#).

Diagnosis Procedure

INFOID:0000000011132173

1. CHECK SELF-DIAGNOSIS RESULTS

Check if "U1000" is detected other than "U0401" in "Self Diagnostic Result" of "ICC/ADAS".

Is "U1000" detected?

- YES >> Perform the CAN communication system inspection. Repair or replace the malfunctioning parts.
Refer to [CCS-165, "ADAS CONTROL UNIT : DTC Logic"](#).
NO >> GO TO 2.

2. CHECK ECM SELF-DIAGNOSIS RESULTS

Check if any DTC is detected in "Self Diagnostic Result" of "ENGINE".

Is any DTC detected?

- YES >> Perform diagnosis on the detected DTC and repair or replace the malfunctioning parts. Refer to [EC-112, "DTC Index"](#) (except for Mexico) or [EC-636, "DTC Index"](#) (for Mexico).
NO >> Replace the ADAS control unit. Refer to [DAS-85, "Removal and Installation"](#).

U0402 TCM CAN 1

< DTC/CIRCUIT DIAGNOSIS >

[ICC]

U0402 TCM CAN 1

DTC Logic

INFOID:0000000011132174

DTC DETECTION LOGIC

DTC (On board display)	Trouble diagnosis name	DTC detecting condition	Possible causes
U0402 (122)	TCM CAN CIRC1	If ADAS control unit detects an error signal that is received from TCM via CAN communication	TCM

NOTE:

If DTC "U0402" is detected along with DTC "U1000", first diagnose the DTC "U1000". Refer to [CCS-165, "ADAS CONTROL UNIT : DTC Logic"](#).

DTC CONFIRMATION PROCEDURE

1. PERFORM DTC CONFIRMATION PROCEDURE

1. Start the engine.
2. Turn the MAIN switch of ICC system ON.
3. Perform "All DTC Reading" with CONSULT.
4. Check if the "U0402" is detected as the current malfunction in "Self Diagnostic Result" of "ICC/ADAS".

Is "U0402" detected as the current malfunction?

- YES >> Refer to [CCS-159, "Diagnosis Procedure"](#).
NO >> Refer to [GI-50, "Intermittent Incident"](#).

Diagnosis Procedure

INFOID:0000000011132175

1. CHECK SELF-DIAGNOSIS RESULTS

Check if "U1000" is detected other than "U0402" in "Self Diagnostic Result" of "ICC/ADAS".

Is "U1000" detected?

- YES >> Perform the CAN communication system inspection. Repair or replace the malfunctioning parts. Refer to [CCS-165, "ADAS CONTROL UNIT : DTC Logic"](#).
NO >> GO TO 2.

2. CHECK TCM SELF-DIAGNOSIS RESULTS

Check if any DTC is detected in "Self Diagnostic Result" of "TRANSMISSION".

Is any DTC detected?

- YES >> Perform diagnosis on the detected DTC and repair or replace the malfunctioning parts. Refer to [TM-63, "DTC Index"](#) (RE0F10E) or [TM-277, "DTC Index"](#) (RE0F10J).
NO >> Replace the ADAS control unit. Refer to [DAS-85, "Removal and Installation"](#).

A
B
C
D
E
F
G
H
I
J
K
L
M
N
P

CCS

U0405 ADAS CAN 2

< DTC/CIRCUIT DIAGNOSIS >

[ICC]

U0405 ADAS CAN 2

DTC Logic

INFOID:0000000011132176

DTC DETECTION LOGIC

DTC	Trouble diagnosis name	DTC detecting condition	Possible causes
U0405	ADAS CAN CIR 2	If ICC sensor detects an error signal that is received from ADAS control unit via ITS communication	ADAS control unit

NOTE:

If DTC "U0405" is detected along with DTC "U1000", first diagnose the DTC "U1000". Refer to [CCS-165, "ICC SENSOR : DTC Logic"](#).

DTC CONFIRMATION PROCEDURE

1. PERFORM DTC CONFIRMATION PROCEDURE

1. Start the engine.
2. Turn the MAIN switch of ICC system ON.
3. Perform "All DTC Reading" with CONSULT.
4. Check if the "U0405" is detected as the current malfunction in "Self Diagnostic Result" of "LASER/RADAR".

Is "U0405" detected as the current malfunction?

- YES >> Refer to [CCS-160, "Diagnosis Procedure"](#).
NO >> Refer to [GI-50, "Intermittent Incident"](#).

Diagnosis Procedure

INFOID:0000000011132177

1. CHECK ICC SENSOR SELF-DIAGNOSIS RESULTS

Check if "U1000" is detected other than "U0405" in "Self Diagnostic Result" of "LASER/RADAR".

Is "U1000" detected?

- YES >> Perform the CAN communication system inspection. Repair or replace the malfunctioning parts.
Refer to [CCS-165, "ICC SENSOR : DTC Logic"](#).
NO >> GO TO 2.

2. CHECK ADAS CONTROL UNIT SELF-DIAGNOSIS RESULTS

Check if any DTC is detected in "Self Diagnostic Result" of "ICC/ADAS".

Is any DTC detected?

- YES >> Perform diagnosis on the detected DTC and repair or replace the malfunctioning parts. Refer to [CCS-60, "DTC Index"](#).
NO >> Replace the ICC sensor. Refer to [CCS-195, "Removal and Installation"](#).

U0415 VDC CAN 1

< DTC/CIRCUIT DIAGNOSIS >

[ICC]

U0415 VDC CAN 1 ADAS CONTROL UNIT ADAS CONTROL UNIT : DTC Logic

INFOID:000000011132178

DTC DETECTION LOGIC

DTC (On board display)	Trouble diagnosis name	DTC detecting condition	Possible causes
U0415 (126)	VDC CAN CIR1	If ADAS control unit detects an error signal that is received from ABS actuator and electric unit (control unit) via CAN communication	ABS actuator and electric unit (control unit)

NOTE:

If DTC "U0415" is detected along with DTC "U1000", first diagnose the DTC "U1000". Refer to [CCS-165, "ADAS CONTROL UNIT : DTC Logic"](#).

DTC CONFIRMATION PROCEDURE

1. PERFORM DTC CONFIRMATION PROCEDURE

1. Start the engine.
2. Turn the MAIN switch of ICC system ON.
3. Perform "All DTC Reading" with CONSULT.
4. Check if the "U0415" is detected as the current malfunction in "Self Diagnostic Result" of "ICC/ADAS".

Is "U0415" detected as the current malfunction?

- YES >> Refer to [CCS-161, "ADAS CONTROL UNIT : Diagnosis Procedure"](#).
NO >> Refer to [GI-50, "Intermittent Incident"](#).

ADAS CONTROL UNIT : Diagnosis Procedure

INFOID:000000011132179

1. CHECK SELF-DIAGNOSIS RESULTS

Check if "U1000" is detected other than "U0415" in "Self Diagnostic Result" of "ICC/ADAS".

Is "U1000" detected?

- YES >> Perform the CAN communication system inspection. Repair or replace the malfunctioning parts. Refer to [CCS-165, "ADAS CONTROL UNIT : DTC Logic"](#).
NO >> GO TO 2.

2. CHECK ABS ACTUATOR AND ELECTRIC UNIT (CONTROL UNIT) SELF-DIAGNOSIS RESULTS

Check if any DTC is detected in "Self Diagnostic Result" of "ABS".

Is any DTC detected?

- YES >> Perform diagnosis on the detected DTC and repair or replace the malfunctioning parts. Refer to [BRC-46, "DTC Index"](#).
NO >> Replace the ADAS control unit. Refer to [DAS-85, "Removal and Installation"](#).

ICC SENSOR

ICC SENSOR : DTC Logic

INFOID:000000011132180

DTC DETECTION LOGIC

DTC	Trouble diagnosis name	DTC detecting condition	Possible causes
U0415	VDC CAN CIR1	If ICC sensor detects an error signal that is received from ABS actuator and electric unit (control unit) via ADAS control unit	ABS actuator and electric unit (control unit)

NOTE:

If DTC "U0415" is detected along with DTC "U1000", first diagnose the DTC "U1000". Refer to [CCS-165, "ICC SENSOR : DTC Logic"](#).

A
B
C
D
E
F
G
H
I
J
K
L
M
N
P



< DTC/CIRCUIT DIAGNOSIS >

DTC CONFIRMATION PROCEDURE

1. PERFORM DTC CONFIRMATION PROCEDURE

1. Start the engine.
2. Turn the MAIN switch of ICC system ON.
3. Perform "All DTC Reading" with CONSULT.
4. Check if the "U0415" is detected as the current malfunction in "Self Diagnostic Result" of "LASER/RADAR".

Is "U0415" detected as the current malfunction?

YES >> Refer to [CCS-162, "ICC SENSOR : Diagnosis Procedure"](#).

NO >> Refer to [GI-50, "Intermittent Incident"](#).

ICC SENSOR : Diagnosis Procedure

INFOID:000000011132181

1. CHECK ICC SENSOR SELF-DIAGNOSIS RESULTS

Check if "U1000" is detected other than "U0415" in "Self Diagnostic Result" of "LASER/RADAR".

Is "U1000" detected?

YES >> Perform the CAN communication system inspection. Repair or replace the malfunctioning parts.
Refer to [CCS-165, "ICC SENSOR : DTC Logic"](#).

NO >> GO TO 2.

2. CHECK ADAS CONTROL UNIT SELF-DIAGNOSIS RESULTS

Check if any DTC is detected in "Self Diagnostic Result" of "ICC/ADAS".

Is any DTC detected?

YES >> Perform diagnosis on the detected DTC and repair or replace the malfunctioning parts. Refer to [CCS-60, "DTC Index"](#).

NO >> Replace the ICC sensor. Refer to [CCS-195, "Removal and Installation"](#).

U0428 STRG SEN CAN 2

< DTC/CIRCUIT DIAGNOSIS >

[ICC]

U0428 STRG SEN CAN 2

ADAS CONTROL UNIT

ADAS CONTROL UNIT : DTC Logic

INFOID:000000011132182

DTC DETECTION LOGIC

DTC (On board display)	Trouble diagnosis name	DTC detecting condition	Possible causes
U0428 (131)	STRG SEN CAN CIR2	If ADAS control unit detects an error signal that is received from steering angle sensor via CAN communication	Steering angle sensor

NOTE:

If DTC "U0428" is detected along with DTC "U1000", first diagnose the DTC "U1000". Refer to [CCS-165, "ADAS CONTROL UNIT : DTC Logic"](#).

DTC CONFIRMATION PROCEDURE

1. PERFORM DTC CONFIRMATION PROCEDURE

1. Start the engine.
2. Turn the MAIN switch of ICC system ON.
3. Perform "All DTC Reading" with CONSULT.
4. Check if the "U0428" is detected as the current malfunction in "Self Diagnostic Result" of "ICC/ADAS".

Is "U0428" detected as the current malfunction?

- YES >> Refer to [CCS-163, "ADAS CONTROL UNIT : Diagnosis Procedure"](#).
NO >> Refer to [GI-50, "Intermittent Incident"](#).

ADAS CONTROL UNIT : Diagnosis Procedure

INFOID:000000011132183

1. CHECK SELF-DIAGNOSIS RESULTS

Check if "U1000" is detected other than "U0428" in "Self Diagnostic Result" of "ICC/ADAS".

Is "U1000" detected?

- YES >> Perform the CAN communication system inspection. Repair or replace the malfunctioning parts. Refer to [CCS-165, "ADAS CONTROL UNIT : DTC Logic"](#).
NO >> GO TO 2.

2. CHECK ABS ACTUATOR AND ELECTRIC UNIT (CONTROL UNIT) SELF-DIAGNOSIS RESULTS

Check if any DTC is detected in "Self Diagnostic Result" of "ABS".

Is any DTC detected?

- YES >> Perform diagnosis on the detected DTC and repair or replace the malfunctioning parts. Refer to [BRC-46, "DTC Index"](#).
NO >> Replace the ADAS control unit. Refer to [DAS-85, "Removal and Installation"](#).

ICC SENSOR

ICC SENSOR : DTC Logic

INFOID:000000011132184

DTC DETECTION LOGIC

DTC	Trouble diagnosis name	DTC detecting condition	Possible causes
U0428	STRG SEN CAN CIR2	If ICC sensor detects an error signal that is received from steering angle sensor via ADAS control unit	Steering angle sensor

NOTE:

If DTC "U0428" is detected along with DTC "U1000", first diagnose the DTC "U1000". Refer to [CCS-165, "ICC SENSOR : DTC Logic"](#).

< DTC/CIRCUIT DIAGNOSIS >

DTC CONFIRMATION PROCEDURE

1. PERFORM DTC CONFIRMATION PROCEDURE

1. Start the engine.
2. Turn the MAIN switch of ICC system ON.
3. Perform "All DTC Reading" with CONSULT.
4. Check if the "U0428" is detected as the current malfunction in "Self Diagnostic Result" of "LASER/RADAR".

Is "U0428" detected as the current malfunction?

YES >> Refer to [CCS-163, "ADAS CONTROL UNIT : Diagnosis Procedure"](#).

NO >> Refer to [GI-50, "Intermittent Incident"](#).

ICC SENSOR : Diagnosis Procedure

INFOID:000000011132185

1. CHECK ICC SENSOR SELF-DIAGNOSIS RESULTS

Check if "U1000" is detected other than "U0428" in "Self Diagnostic Result" of "LASER/RADAR".

Is "U1000" detected?

YES >> Perform the CAN communication system inspection. Repair or replace the malfunctioning parts.
Refer to [CCS-165, "ICC SENSOR : DTC Logic"](#).

NO >> GO TO 2.

2. CHECK ADAS CONTROL UNIT SELF-DIAGNOSIS RESULTS

Check if any DTC is detected in "Self Diagnostic Result" of "ICC/ADAS".

Is any DTC detected?

YES >> Perform diagnosis on the detected DTC and repair or replace the malfunctioning parts. Refer to [CCS-60, "DTC Index"](#).

NO >> Replace the ICC sensor. Refer to [CCS-195, "Removal and Installation"](#).

U1000 CAN COMM CIRCUIT

< DTC/CIRCUIT DIAGNOSIS >

[ICC]

U1000 CAN COMM CIRCUIT

ADAS CONTROL UNIT

ADAS CONTROL UNIT : Description

INFOID:0000000011132186

CAN COMMUNICATION

CAN (Controller Area Network) is a serial communication line for real time applications. It is an on-vehicle multiplex communication line with high data communication speed and excellent error detection ability. Modern vehicle is equipped with many electronic control units, and each control unit shares information and links with other control units during operation (not independent). In CAN communication, control units are connected with 2 communication lines (CAN-H, CAN-L) allowing a high rate of information transmission with less wiring. Each control unit transmits/receives data but selectively reads the required data only.

CAN communication signal chart. Refer to [LAN-45. "CAN COMMUNICATION SYSTEM : CAN Communication Signal Chart"](#).

ITS COMMUNICATION

- ITS communication is a multiplex communication system. This enables the system to transmit and receive large quantities of data at high speed by connecting control units with 2 communication lines.
- ITS communication lines adopt twisted-pair line style (two lines twisted) for noise immunity.

ADAS CONTROL UNIT : DTC Logic

INFOID:0000000011132187

DTC DETECTION LOGIC

DTC (On board display)	Trouble diagnosis name	DTC detecting condition	Possible causes
U1000 (100)	CAN COMM CIRCUIT	If ADAS control unit is not transmitting or receiving CAN communication signal or ITS communication signal for 2 seconds or more	<ul style="list-style-type: none">• CAN communication system• ITS communication system

NOTE:

If "U1000" is detected, first diagnose the CAN communication system.

ADAS CONTROL UNIT : Diagnosis Procedure

INFOID:0000000011132188

1. PERFORM THE SELF-DIAGNOSIS

1. Turn the ignition switch ON.
2. Turn the MAIN switch of ICC system ON, and then wait for 30 seconds or more.
3. Perform "All DTC Reading" with CONSULT.
4. Check if the "U1000" is detected as the current malfunction in "Self Diagnostic Result" of "ICC/ADAS".

Is "U1000" detected as the current malfunction?

YES >> Refer to [LAN-28. "Trouble Diagnosis Flow Chart"](#).

NO >> Refer to [GI-50. "Intermittent Incident"](#).

ICC SENSOR

ICC SENSOR : Description

INFOID:0000000011132189

ITS COMMUNICATION

- ITS communication is a multiplex communication system. This enables the system to transmit and receive large quantities of data at high speed by connecting control units with 2 communication lines
- ITS communication lines adopt twisted-pair line style (two lines twisted) for noise immunity.

ICC SENSOR : DTC Logic

INFOID:0000000011132190

DTC DETECTION LOGIC

U1000 CAN COMM CIRCUIT

< DTC/CIRCUIT DIAGNOSIS >

[ICC]

DTC	Trouble diagnosis name	DTC detecting condition	Possible causes
U1000	CAN COMM CIRCUIT	If ICC sensor is not transmitting or receiving ITS communication signal for 2 seconds or more	ITS communication system

ICC SENSOR : Diagnosis Procedure

INFOID:000000011132191

1. PERFORM THE SELF-DIAGNOSIS

1. Turn the ignition switch ON.
2. Turn the MAIN switch of ICC system ON, and then wait for 2 seconds or more.
3. Perform "All DTC Reading" with CONSULT.
4. Check if the "U1000" is detected as the current malfunction in "Self Diagnostic Result" of "LASER/RADAR".

Is "U1000" detected as the current malfunction?

- YES >> Refer to [LAN-28. "Trouble Diagnosis Flow Chart"](#).
NO >> Refer to [GI-50. "Intermittent Incident"](#).

U1010 CONTROL UNIT (CAN)

< DTC/CIRCUIT DIAGNOSIS >

[ICC]

U1010 CONTROL UNIT (CAN)

ADAS CONTROL UNIT

ADAS CONTROL UNIT : Description

INFOID:0000000011132192

CAN controller controls the communication of CAN communication signal and ITS communication signal, and the error detection.

ADAS CONTROL UNIT : DTC Logic

INFOID:0000000011132193

DTC DETECTION LOGIC

DTC (On board display)	Trouble diagnosis name	DTC detecting condition	Possible causes
U1010 (110)	CONTROL UNIT (CAN)	If ADAS control unit detects malfunction by CAN controller initial diagnosis	ADAS control unit

ADAS CONTROL UNIT : Diagnosis Procedure

INFOID:0000000011132194

1.PERFORM DTC CONFIRMATION PROCEDURE

1. Turn the MAIN switch of ICC system ON.
2. Perform "All DTC Reading" with CONSULT.
3. Check if the "U1010" is detected as the current malfunction in "Self Diagnostic Result" of "ICC/ADAS".

Is "U1010" detected as the current malfunction?

- YES >> Replace the ADAS control unit. Refer to [DAS-85, "Removal and Installation"](#).
NO >> INSPECTION END

ICC SENSOR

ICC SENSOR : Description

INFOID:0000000011132195

CAN controller controls the communication of ITS communication signal and the error detection.

ICC SENSOR : DTC Logic

INFOID:0000000011132196

DTC DETECTION LOGIC

DTC	Trouble diagnosis name	DTC detecting condition	Possible causes
U1010	CONTROL UNIT (CAN)	If ICC sensor detects malfunction by CAN controller initial diagnosis	ICC sensor

ICC SENSOR : Diagnosis Procedure

INFOID:0000000011132197

1.PERFORM DTC CONFIRMATION PROCEDURE

1. Turn the MAIN switch of ICC system ON.
2. Perform "All DTC Reading" with CONSULT.
3. Check if the "U1010" is detected as the current malfunction in "Self Diagnostic Result" of "LASER/RADAR".

Is "U1010" detected as the current malfunction?

- YES >> Replace the ICC sensor. Refer to [CCS-195, "Removal and Installation"](#).
NO >> INSPECTION END

A
B
C
D
E
F
G
H
I
J
K
L
M
N
P

CCS

U150B ECM CAN 3

< DTC/CIRCUIT DIAGNOSIS >

[ICC]

U150B ECM CAN 3

DTC Logic

INFOID:0000000011132198

DTC DETECTION LOGIC

DTC (On board display)	Trouble diagnosis name	DTC detecting condition	Possible causes
U150B (157)	ECM CAN CIRC 3	ADAS control unit detects an error signal that is received from ECM via CAN communication	ECM

NOTE:

If DTC "U150B" is detected along with DTC "U1000", first diagnose the DTC "U1000". Refer to [CCS-165. "ADAS CONTROL UNIT : DTC Logic"](#).

DTC CONFIRMATION PROCEDURE

1. PERFORM DTC CONFIRMATION PROCEDURE

1. Start the engine.
2. Turn the MAIN switch of ICC system ON.
3. Perform "All DTC Reading" with CONSULT.
4. Check if the "U150B" is detected as the current malfunction in "Self Diagnostic Result" of "ICC/ADAS".

Is "U150B" detected as the current malfunction?

- YES >> Refer to [CCS-168. "Diagnosis Procedure"](#).
NO >> Refer to [GI-50. "Intermittent Incident"](#).

Diagnosis Procedure

INFOID:0000000011132199

1. CHECK SELF-DIAGNOSIS RESULTS

Check if "U1000" is detected other than "U150B" in "Self Diagnostic Result" of "ICC/ADAS".

Is "U1000" detected?

- YES >> Perform the CAN communication system inspection. Repair or replace the malfunctioning parts.
Refer to [CCS-165. "ADAS CONTROL UNIT : DTC Logic"](#).
NO >> GO TO 2.

2. CHECK ECM SELF-DIAGNOSIS RESULTS

Check if any DTC is detected in "Self Diagnostic Result" of "ENGINE".

Is any DTC detected?

- YES >> Perform diagnosis on the detected DTC and repair or replace the malfunctioning parts. Refer to [EC-112. "DTC Index"](#) (except for Mexico) or [EC-636. "DTC Index"](#) (for Mexico).
NO >> Replace the ADAS control unit. Refer to [DAS-85. "Removal and Installation"](#).

U150C VDC CAN 3

< DTC/CIRCUIT DIAGNOSIS >

[ICC]

U150C VDC CAN 3

DTC Logic

INFOID:0000000011132200

DTC DETECTION LOGIC

DTC (On board display)	Trouble diagnosis name	DTC detecting condition	Possible causes
U150C (158)	VDC CAN CIRC 3	ADAS control unit detects an error signal that is received from ABS actuator and electric unit (control unit) via CAN communication	ABS actuator and electric unit (control unit)

NOTE:

If DTC "U150C" is detected along with DTC "U1000", first diagnose the DTC "U1000". Refer to [CCS-165, "ADAS CONTROL UNIT : DTC Logic"](#).

DTC CONFIRMATION PROCEDURE

1. PERFORM DTC CONFIRMATION PROCEDURE

1. Start the engine.
2. Turn the MAIN switch of ICC system ON.
3. Perform "All DTC Reading" with CONSULT.
4. Check if the "U150C" is detected as the current malfunction in "Self Diagnostic Result" of "ICC/ADAS".

Is "U150C" detected as the current malfunction?

- YES >> Refer to [CCS-169, "Diagnosis Procedure"](#).
NO >> Refer to [GI-50, "Intermittent Incident"](#).

Diagnosis Procedure

INFOID:0000000011132201

1. CHECK SELF-DIAGNOSIS RESULTS

Check if "U1000" is detected other than "U150C" in "Self Diagnostic Result" of "ICC/ADAS".

Is "U1000" detected?

- YES >> Perform the CAN communication system inspection. Repair or replace the malfunctioning parts. Refer to [CCS-165, "ADAS CONTROL UNIT : DTC Logic"](#).
NO >> GO TO 2.

2. CHECK ABS ACTUATOR AND ELECTRIC UNIT (CONTROL UNIT) SELF-DIAGNOSIS RESULTS

Check if any DTC is detected in "Self Diagnostic Result" of "ABS".

Is any DTC detected?

- YES >> Perform diagnosis on the detected DTC and repair or replace the malfunctioning parts. Refer to [BRC-46, "DTC Index"](#).
NO >> Replace the ADAS control unit. Refer to [DAS-85, "Removal and Installation"](#).

A
B
C
D
E
F
G
H
I
J
K
L
M
N
P

CCS

U150D TCM CAN 3

< DTC/CIRCUIT DIAGNOSIS >

[ICC]

U150D TCM CAN 3

DTC Logic

INFOID:000000011132202

DTC DETECTION LOGIC

DTC (On board display)	Trouble diagnosis name	DTC detecting condition	Possible causes
U150D (159)	TCM CAN CIRC 3	ADAS control unit detects an error signal that is received from TCM via CAN communication	TCM

NOTE:

If DTC "U150D" is detected along with DTC "U1000", first diagnose the DTC "U1000". Refer to [CCS-165. "ADAS CONTROL UNIT : DTC Logic"](#).

DTC CONFIRMATION PROCEDURE

1. PERFORM DTC CONFIRMATION PROCEDURE

1. Start the engine.
2. Turn the MAIN switch of ICC system ON.
3. Perform "All DTC Reading" with CONSULT.
4. Check if the "U150D" is detected as the current malfunction in "Self Diagnostic Result" of "ICC/ADAS".

Is "U150D" detected as the current malfunction?

- YES >> Refer to [CCS-170. "Diagnosis Procedure"](#).
NO >> Refer to [GI-50. "Intermittent Incident"](#).

Diagnosis Procedure

INFOID:000000011132203

1. CHECK SELF-DIAGNOSIS RESULTS

Check if "U1000" is detected other than "U150D" in "Self Diagnostic Result" of "ICC/ADAS".

Is "U1000" detected?

- YES >> Perform the CAN communication system inspection. Repair or replace the malfunctioning parts.
Refer to [CCS-165. "ADAS CONTROL UNIT : DTC Logic"](#).
NO >> GO TO 2.

2. CHECK TCM SELF-DIAGNOSIS RESULTS

Check if any DTC is detected in "Self Diagnostic Result" of "TRANSMISSION".

Is any DTC detected?

- YES >> Perform diagnosis on the detected DTC and repair or replace the malfunctioning parts. Refer to [TM-63. "DTC Index"](#) (RE0F10E) or [TM-277. "DTC Index"](#) (RE0F10J).
NO >> Replace the ADAS control unit. Refer to [DAS-85. "Removal and Installation"](#).

U150E BCM CAN 3

< DTC/CIRCUIT DIAGNOSIS >

[ICC]

U150E BCM CAN 3

DTC Logic

INFOID:0000000011132204

DTC DETECTION LOGIC

DTC (On board display)	Trouble diagnosis name	DTC detecting condition	Possible causes
U150E (160)	BCM CAN CIRC 3	ADAS control unit detects an error signal that is received from BCM via CAN communication	BCM

NOTE:

If DTC "U150E" is detected along with DTC "U1000", first diagnose the DTC "U1000". Refer to [CCS-165, "ADAS CONTROL UNIT : DTC Logic"](#).

DTC CONFIRMATION PROCEDURE

1. PERFORM DTC CONFIRMATION PROCEDURE

1. Start the engine.
2. Turn the MAIN switch of ICC system ON.
3. Perform "All DTC Reading" with CONSULT.
4. Check if the "U150E" is detected as the current malfunction in "Self Diagnostic Result" of "ICC/ADAS".

Is "U150E" detected as the current malfunction?

- YES >> Refer to [CCS-171, "Diagnosis Procedure"](#).
NO >> Refer to [GI-50, "Intermittent Incident"](#).

Diagnosis Procedure

INFOID:0000000011132205

1. CHECK SELF-DIAGNOSIS RESULTS

Check if "U1000" is detected other than "U150E" in "Self Diagnostic Result" of "ICC/ADAS".

Is "U1000" detected?

- YES >> Perform the CAN communication system inspection. Repair or replace the malfunctioning parts.
Refer to [CCS-165, "ADAS CONTROL UNIT : DTC Logic"](#).
NO >> GO TO 2.

2. CHECK BCM SELF-DIAGNOSIS RESULTS

Check if any DTC is detected in "Self Diagnostic Result" of "BCM".

Is any DTC detected?

- YES >> Perform diagnosis on the detected DTC and repair or replace the malfunctioning parts. Refer to [BCS-51, "DTC Index"](#).
NO >> Replace the ADAS control unit. Refer to [DAS-85, "Removal and Installation"](#).

A
B
C
D
E
F
G
H
I
J
K
L
M
N
P

CCS

U1502 ICC SENSOR CAN COMM CIRC

< DTC/CIRCUIT DIAGNOSIS >

[ICC]

U1502 ICC SENSOR CAN COMM CIRC

DTC Logic

INFOID:0000000011132206

DTC DETECTION LOGIC

DTC (On board display)	Trouble diagnosis name	DTC detecting condition	Possible causes
U1502 (147)	ICC SEN CAN COMM CIR	ADAS control unit detects an error signal that is received from ICC sensor via CAN communication	ICC sensor

NOTE:

If DTC "U1502" is detected along with DTC "U1000", first diagnose the DTC "U1000". Refer to [CCS-165, "ADAS CONTROL UNIT : DTC Logic"](#).

DTC CONFIRMATION PROCEDURE

1. PERFORM DTC CONFIRMATION PROCEDURE

1. Start the engine.
2. Turn the MAIN switch of ICC system ON.
3. Perform "All DTC Reading" with CONSULT.
4. Check if the "U1502" is detected as the current malfunction in "Self Diagnostic Result" of "ICC/ADAS".

Is "U1502" detected as the current malfunction?

- YES >> Refer to [CCS-172, "Diagnosis Procedure"](#).
NO >> Refer to [GI-50, "Intermittent Incident"](#).

Diagnosis Procedure

INFOID:0000000011132207

1. CHECK SELF-DIAGNOSIS RESULTS

Check if "U1000" is detected other than "U1502" in "Self Diagnostic Result" of "ICC/ADAS".

Is "U1000" detected?

- YES >> Perform the CAN communication system inspection. Repair or replace the malfunctioning parts.
Refer to [CCS-165, "ADAS CONTROL UNIT : DTC Logic"](#).
NO >> GO TO 2.

2. CHECK ICC SENSOR SELF-DIAGNOSIS RESULTS

Check if any DTC is detected in "Self Diagnostic Result" of "LASER/RADAR".

Is any DTC detected?

- YES >> Perform diagnosis on the detected DTC and repair or replace the malfunctioning parts. Refer to [CCS-66, "DTC Index"](#).
NO >> Replace the ADAS control unit. Refer to [DAS-85, "Removal and Installation"](#).

U1513 METER CAN 3

< DTC/CIRCUIT DIAGNOSIS >

[ICC]

U1513 METER CAN 3

DTC Logic

INFOID:0000000011132208

DTC DETECTION LOGIC

DTC (On board display)	Trouble diagnosis name	DTC detecting condition	Possible causes
U1513 (163)	METER CAN CIRC 3	ADAS control unit detects an error signal that is received from combination meter via CAN communication	Combination meter

NOTE:

If DTC "U1513" is detected along with DTC "U1000", first diagnose the DTC "U1000". Refer to [CCS-165, "ADAS CONTROL UNIT : DTC Logic"](#).

DTC CONFIRMATION PROCEDURE

1. PERFORM DTC CONFIRMATION PROCEDURE

1. Start the engine.
2. Turn the MAIN switch of ICC system ON.
3. Perform "All DTC Reading" with CONSULT.
4. Check if the "U1513" is detected as the current malfunction in "Self Diagnostic Result" of "ICC/ADAS".

Is "U1513" detected as the current malfunction?

- YES >> Refer to [CCS-173, "Diagnosis Procedure"](#).
NO >> Refer to [GI-50, "Intermittent Incident"](#).

Diagnosis Procedure

INFOID:0000000011132209

1. CHECK SELF-DIAGNOSIS RESULTS

Check if "U1000" is detected other than "U1513" in "Self Diagnostic Result" of "ICC/ADAS".

Is "U1000" detected?

- YES >> Perform the CAN communication system inspection. Repair or replace the malfunctioning parts. Refer to [CCS-165, "ADAS CONTROL UNIT : DTC Logic"](#).
NO >> GO TO 2.

2. CHECK COMBINATION METER SELF-DIAGNOSIS RESULTS

Check if any DTC is detected in "Self Diagnostic Result" of "METER/M&A".

Is any DTC detected?

- YES >> Perform diagnosis on the detected DTC and repair or replace the malfunctioning parts. Refer to [MWI-26, "DTC Index"](#).
NO >> Replace the ADAS control unit. Refer to [DAS-85, "Removal and Installation"](#).

A
B
C
D
E
F
G
H
I
J
K
L
M
N
P

CCS

U1514 STRG SEN CAN 3

DTC Logic

INFOID:0000000011132210

DTC DETECTION LOGIC

DTC (On board display)	Trouble diagnosis name	DTC detecting condition	Possible causes
U1514 (165)	STRG SEN CAN CIRC 3	ADAS control unit detects an error signal that is received from steering angle sensor via CAN communication	Steering angle sensor

NOTE:

If DTC "U1514" is detected along with DTC "U1000", first diagnose the DTC "U1000". Refer to [CCS-165, "ADAS CONTROL UNIT : DTC Logic"](#).

DTC CONFIRMATION PROCEDURE

1. PERFORM DTC CONFIRMATION PROCEDURE

1. Start the engine.
2. Turn the MAIN switch of ICC system ON.
3. Perform "All DTC Reading" with CONSULT.
4. Check if the "U1514" is detected as the current malfunction in "Self Diagnostic Result" of "ICC/ADAS".

Is "U1514" detected as the current malfunction?

- YES >> Refer to [CCS-174, "Diagnosis Procedure"](#).
 NO >> Refer to [GI-50, "Intermittent Incident"](#).

Diagnosis Procedure

INFOID:0000000011132211

1. CHECK SELF-DIAGNOSIS RESULTS

Check if "U1000" is detected other than "U1514" in "Self Diagnostic Result" of "ICC/ADAS".

Is "U1000" detected?

- YES >> Perform the CAN communication system inspection. Repair or replace the malfunctioning parts. Refer to [CCS-165, "ADAS CONTROL UNIT : DTC Logic"](#).
 NO >> GO TO 2.

2. CHECK ABS ACTUATOR AND ELECTRIC UNIT (CONTROL UNIT) SELF-DIAGNOSIS RESULTS

Check if any DTC is detected in "Self Diagnostic Result" of "ABS".

Is any DTC detected?

- YES >> Perform diagnosis on the detected DTC and repair or replace the malfunctioning parts. Refer to [BRC-46, "DTC Index"](#).
 NO >> Replace the ADAS control unit. Refer to [DAS-85, "Removal and Installation"](#).

U1515 ICC SENSOR CAN 3

< DTC/CIRCUIT DIAGNOSIS >

[ICC]

U1515 ICC SENSOR CAN 3

DTC Logic

INFOID:0000000011132212

DTC DETECTION LOGIC

DTC (On board display)	Trouble diagnosis name	DTC detecting condition	Possible causes
U1515 (165)	ICC SENSOR CAN CIRC 3	ADAS control unit detects an error signal that is received from ICC sensor via CAN communication	ICC sensor

NOTE:

If DTC "U1515" is detected along with DTC "U1000", first diagnose the DTC "U1000". Refer to [CCS-165, "ADAS CONTROL UNIT : DTC Logic"](#).

DTC CONFIRMATION PROCEDURE

1. PERFORM DTC CONFIRMATION PROCEDURE

1. Start the engine.
2. Turn the MAIN switch of ICC system ON.
3. Perform "All DTC Reading" with CONSULT.
4. Check if the "U1515" is detected as the current malfunction in "Self Diagnostic Result" of "ICC/ADAS".

Is "U1515" detected as the current malfunction?

- YES >> Refer to [CCS-175, "Diagnosis Procedure"](#).
NO >> Refer to [GI-50, "Intermittent Incident"](#).

Diagnosis Procedure

INFOID:0000000011132213

1. CHECK SELF-DIAGNOSIS RESULTS

Check if "U1000" is detected other than "U1515" in "Self Diagnostic Result" of "ICC/ADAS".

Is "U1000" detected?

- YES >> Perform the CAN communication system inspection. Repair or replace the malfunctioning parts. Refer to [CCS-165, "ADAS CONTROL UNIT : DTC Logic"](#).
NO >> GO TO 2.

2. CHECK ICC SENSOR SELF-DIAGNOSIS RESULTS

Check if any DTC is detected in "Self Diagnostic Result" of "LASER/RADAR".

Is any DTC detected?

- YES >> Perform diagnosis on the detected DTC and repair or replace the malfunctioning parts. Refer to [CCS-66, "DTC Index"](#).
NO >> Replace the ADAS control unit. Refer to [DAS-85, "Removal and Installation"](#).

A
B
C
D
E
F
G
H
I
J
K
L
M
N
P

CCS

U1517 ACCELERATOR PEDAL ACTUATOR CAN 3

< DTC/CIRCUIT DIAGNOSIS >

[ICC]

U1517 ACCELERATOR PEDAL ACTUATOR CAN 3

DTC Logic

INFOID:0000000011132214

DTC DETECTION LOGIC

DTC (On board display)	Trouble diagnosis name	DTC detecting condition	Possible causes
U1517 (167)	APA CAN CIRC 3	ADAS control unit detects an error signal that is received from accelerator pedal actuator via CAN communication	Accelerator pedal actuator

NOTE:

If DTC "U1517" is detected along with DTC "U1000", first diagnose the DTC "U1000". Refer to [CCS-165, "ADAS CONTROL UNIT : DTC Logic"](#).

DTC CONFIRMATION PROCEDURE

1. PERFORM DTC CONFIRMATION PROCEDURE

1. Start the engine.
2. Turn the MAIN switch of ICC system ON.
3. Perform "All DTC Reading" with CONSULT.
4. Check if the "U1517" is detected as the current malfunction in "Self Diagnostic Result" of "ICC/ADAS".

Is "U1517" detected as the current malfunction?

- YES >> Refer to [CCS-176, "Diagnosis Procedure"](#).
NO >> Refer to [GI-50, "Intermittent Incident"](#).

Diagnosis Procedure

INFOID:0000000011132215

1. CHECK SELF-DIAGNOSIS RESULTS

Check if "U1000" is detected other than "U1517" in "Self Diagnostic Result" of "ICC/ADAS".

Is "U1000" detected?

- YES >> Perform the CAN communication system inspection. Repair or replace the malfunctioning parts.
Refer to [CCS-165, "ADAS CONTROL UNIT : DTC Logic"](#).
NO >> GO TO 2.

2. CHECK ACCELERATOR PEDAL ACTUATOR SELF-DIAGNOSIS RESULTS

Check if any DTC is detected in "Self Diagnostic Result" of "ACCELE PEDAL ACT".

Is any DTC detected?

- YES >> Perform diagnosis on the detected DTC and repair or replace the malfunctioning parts. Refer to [DAS-48, "DTC Index"](#).
NO >> Replace the ADAS control unit. Refer to [DAS-85, "Removal and Installation"](#).

POWER SUPPLY AND GROUND CIRCUIT

< DTC/CIRCUIT DIAGNOSIS >

[ICC]

POWER SUPPLY AND GROUND CIRCUIT ADAS CONTROL UNIT

ADAS CONTROL UNIT : Diagnosis Procedure

INFOID:000000011558848

Regarding Wiring Diagram information, refer to [DAS-53. "Wiring Diagram"](#).

1. CHECK ADAS CONTROL UNIT POWER SUPPLY CIRCUIT

Check voltage between ADAS control unit harness connector and ground.

Terminal		Condition	Voltage (Approx.)
(+)	(-)		
ADAS control unit		Ignition switch	0 V
Connector	Terminal		
B104	16	OFF	0 V
		ON	Battery voltage

Is the inspection result normal?

YES >> GO TO 2.

NO >> Repair the ADAS control unit power supply circuit.

2. CHECK ADAS CONTROL UNIT GROUND CIRCUIT

1. Turn the ignition switch OFF.
2. Disconnect the ADAS control unit connector.
3. Check for continuity between ADAS control unit harness connector and ground.

ADAS control unit		Ground	Continuity
Connector	Terminal		
B104	6		Yes

Is the inspection result normal?

YES >> INSPECTION END

NO >> Repair the ADAS control unit ground circuit.

ICC SENSOR

ICC SENSOR : Diagnosis Procedure

INFOID:000000011132217

1. CHECK ICC SENSOR POWER SUPPLY CIRCUIT

Check voltage between ICC sensor harness connector and ground.

Terminal				Condition	Standard voltage	Reference voltage (Approx.)
(+)		(-)				
ICC sensor				Ignition switch	0 - 0.1 V	0 V
Connector	Terminal	Connector	Terminal			
E219	1	E219	8	OFF	0 - 0.1 V	0 V
				ON	9.5 - 16 V	Battery voltage

Is the inspection result normal?

YES >> GO TO 2.

NO >> Repair the ICC sensor power supply circuit.

POWER SUPPLY AND GROUND CIRCUIT

< DTC/CIRCUIT DIAGNOSIS >

[ICC]

2. CHECK ICC SENSOR GROUND CIRCUIT

1. Turn the ignition switch OFF.
2. Disconnect the ICC sensor connector.
3. Check for continuity between ICC sensor harness connector and ground.

ICC sensor		Ground	Continuity
Connector	Terminal		
E219	8		Existed

Is the inspection result normal?

- YES >> INSPECTION END
NO >> Repair the ICC sensor ground circuit.

INTELLIGENT CRUISE CONTROL SYSTEM SYMPTOMS

< SYMPTOM DIAGNOSIS >

[ICC]

SYMPTOM DIAGNOSIS

INTELLIGENT CRUISE CONTROL SYSTEM SYMPTOMS

Symptom Table

INFOID:0000000011132218

Symptoms		Reference page
Operation	MAIN switch does not turn ON	Refer to CCS-180, "Description"
	MAIN switch does not turn OFF	
	ICC system cannot be set (MAIN switch turns ON/OFF)	Refer to CCS-181, "Description"
	CANCEL switch does not function	Refer to CCS-183, "Description"
	Resume does not function	
	Set speed does not increase	
	Set distance to a vehicle ahead cannot be changed	
	ICC is not canceled when the CVT selector lever is "N" position	Refer to CCS-184, "Description"
Display/Chime	ICC system display not appear	Refer to MWI-17, "Description"
	Chime does not sound	Refer to CCS-185, "Description"
Control	Driving force is hunting	Refer to CCS-187, "Description"
Function to detect a vehicle ahead	System frequently cannot detect a vehicle ahead	Refer to CCS-188, "Description"
	Distance to detect a vehicle ahead is short	
	System misidentifies a vehicle even though there is no vehicle ahead	<ul style="list-style-type: none"> Adjust radar alignment: Refer to CCS-89, "Description" Perform ICC system action test. Refer to CCS-97, "Description"
	System misidentifies a vehicle in the next lane	
	System does not detect a vehicle at all	Refer to CCS-190, "Description"

A
B
C
D
E
F
G
H
I
J
K
L
M
N
P



MAIN SWITCH DOES NOT TURN ON, MAIN SWITCH DOES NOT TURN OFF

< SYMPTOM DIAGNOSIS >

[ICC]

MAIN SWITCH DOES NOT TURN ON, MAIN SWITCH DOES NOT TURN OFF

Description

INFOID:0000000011132219

MAIN switch does not turn ON

- ICC system display does not appear even when MAIN switch is pressed.

MAIN switch does not turn OFF

- When ICC system display is ON, display does not turn OFF even if MAIN switch is pressed.

NOTE:

When ICC system warning lamp illuminates, perform the self-diagnosis of ICC system, and then repair or replace the malfunctioning parts.

Diagnosis Procedure

INFOID:0000000011132220

1.MAIN SWITCH INSPECTION

1. Start the engine.
2. Check that "MAIN SW" and "CRUISE LAMP" operate normally in "DATA MONITOR" of "ICC/ADAS" with CONSULT.

Is the inspection result normal?

YES >> GO TO 2.

NO >> GO TO 4.

2.CHECK COMBINATION METER

Check that "CRUISE IND" operates normally in "DATA MONITOR" of "METER/M&A".

Is the inspection result normal?

YES >> GO TO 3.

NO >> GO TO 4.

3.PERFORM SELF-DIAGNOSIS OF COMBINATION METER

1. Perform "Self Diagnostic Result" of "METER/M&A".
2. Check if DTC is detected. Refer to [MWI-26. "DTC Index"](#).

Is any DTC detected?

YES >> Repair or replace malfunctioning parts.

NO >> GO TO 4.

4.PERFORM SELF-DIAGNOSIS RESULTS OF ICC SYSTEM

1. Perform "All DTC Reading".
2. Check if the "U1000" is detected in self-diagnosis results of "ICC/ADAS".

Is "U1000" detected?

YES >> GO TO 5.

NO >> GO TO 6.

5.CAN COMMUNICATIONS INSPECTION

Check the CAN communication and repair or replace malfunctioning parts. Refer to [CCS-165. "ADAS CONTROL UNIT : DTC Logic"](#).

>> INSPECTION END

6.CHECK ICC STEERING SWITCH

Check the ICC steering switch. Refer to [CCS-115. "Component Inspection"](#).

>> INSPECTION END

ICC SYSTEM CANNOT BE SET (MAIN SWITCH TURNS ON/OFF)

< SYMPTOM DIAGNOSIS >

[ICC]

ICC SYSTEM CANNOT BE SET (MAIN SWITCH TURNS ON/OFF)

Description

INFOID:0000000011132221

The MAIN switch can be turned ON/OFF, but the ICC system cannot be set even if the SET/COAST switch is pressed.

NOTE:

The system cannot be set in the following case.

- When the vehicle ahead is not detected below the speed of 32 km/h (20 MPH).
- When the selector lever is not in the "D" position or manual mode.
- When the brake pedal is depressed.
- When the VDC is turned OFF.
- When ABS or VDC (including the TCS) operates.
- When a wheel slips.
- When the drive mode select switch is in SNOW position.
- When ABS warning lamp is ON.

Diagnosis Procedure

INFOID:0000000011132222

1. CHECK CAUSE OF AUTOMATIC CANCELLATION

Check if there is the cancellation cause in the "CAUSE OF AUTO-CANCEL" on "WORK SUPPORT" of "ICC/ADAS" with CONSULT.

Is it displayed?

Not displayed >> GO TO 2.

"OPE SW VOLT CIRC" >> Refer to [CCS-114, "DTC Logic"](#).

"VHCL SPD UNMATCH" >> Refer to [CCS-107, "DTC Logic"](#).

"IGN LOW VOLT" >> Refer to [CCS-105, "ADAS CONTROL UNIT : DTC Logic"](#).

"ECM CIRCUIT" >> Refer to [CCS-125, "DTC Logic"](#).

"CAN COMM ERROR" >> Refer to [CCS-165, "ADAS CONTROL UNIT : DTC Logic"](#).

"ICC SENSOR CAN COMM ERR" >> Refer to [CCS-157, "DTC Logic"](#).

"ABS/TCS/VDC CIRC" >> Refer to [CCS-109, "DTC Logic"](#).

"ECD CIRCUIT" >> Refer to [CCS-137, "DTC Logic"](#).

2. PERFORM THE SELF-DIAGNOSIS

1. Perform "All DTC Reading".
2. Check if any DTC is detected in "Self Diagnostic Result" of "ICC/ADAS" of "LASER/RADAR". Refer to [CCS-60, "DTC Index"](#) (ICC/ADAS) or [CCS-66, "DTC Index"](#) (LASER/RADAR).

Is any DTC detected?

YES >> GO TO 3.

NO >> GO TO 4.

3. REPAIR OR REPLACE MALFUNCTIONING PARTS

Repair or replace malfunctioning parts identified by the self-diagnosis result.

>> GO TO 6.

4. CHECK EACH SWITCH AND VEHICLE SPEED SIGNAL

1. Start the engine.
2. Check that the following items operate normally in "DATA MONITOR" of "ICC/ADAS".
 - "VHCL SPEED SE"
 - "D RANGE SW"
 - "SET/COAST SW"
 - "BRAKE SW"
 - "PKB SW"

Is there a malfunctioning item?

All items are normal >> GO TO 5.

"VHCL SPEED SE" >> Refer to [CCS-107, "DTC Logic"](#).

"D RANGE SW" >> Refer to [CCS-184, "Diagnosis Procedure"](#).

"SET/COAST SW" >> Refer to [CCS-114, "DTC Logic"](#).

A

B

C

D

E

F

G

H

I

J

K

L

M

N

CCS

P

ICC SYSTEM CANNOT BE SET (MAIN SWITCH TURNS ON/OFF)

< SYMPTOM DIAGNOSIS >

[ICC]

“BRAKE SW”>>Refer to [CCS-110, "DTC Logic"](#).

“PKB SW”>>Refer to [MWI-84, "Diagnosis Procedure"](#).

5.REPLACE ADAS CONTROL UNIT

Replace the ADAS control unit. Refer to [DAS-85, "Removal and Installation"](#).

>> GO TO 6.

6.CHECK ICC SYSTEM

-
1. Erase the self-diagnosis results, and then perform “All DTC Reading” again after performing the action test. (Refer to [CCS-97, "Description"](#) for action test.)
 2. Check that the ICC system is normal.

>> INSPECTION END

ICC STEERING SWITCH (OTHER THAN MAIN SWITCH) DOES NOT FUNCTION

< SYMPTOM DIAGNOSIS >

[ICC]

ICC STEERING SWITCH (OTHER THAN MAIN SWITCH) DOES NOT FUNCTION

Description

INFOID:0000000011132223

MAIN switch can be turned ON/OFF, but the operation of RESUME/ACCELERATE switch, CANCEL switch, and DISTANCE switch cannot be performed during ICC system operation.

NOTE:

Resume is not accepted when the following condition is met.

- When the MAIN switch is turned OFF once.

The set distance change is not accepted when any of the following condition is met.

- When the DCA system is turned ON.

Diagnosis Procedure

INFOID:0000000011132224

1. CHECK EACH SWITCH

1. Start the engine.
2. Check that each switch operates normally on "DATA MONITOR" of "ICC/ADAS" with CONSULT.
 - "RESUME/ACC SW"
 - "CANCEL SW"
 - "DISTANCE SW"

Is the inspection result normal?

YES >> GO TO 5.

NO >> GO TO 2.

2. PERFORM ALL OF THE SELF-DIAGNOSIS ITEMS

1. Perform "All DTC Reading".
2. Check if the "U1000" is detected in "Self Diagnostic Result" of "ICC/ADAS".

Is "U1000" detected?

YES >> GO TO 3.

NO >> GO TO 4.

3. CAN COMMUNICATIONS INSPECTION

Check the CAN communication and repair or replace malfunctioning parts. Refer to [CCS-165. "ADAS CONTROL UNIT : DTC Logic"](#).

>> INSPECTION END

4. CHECK ICC STEERING SWITCH

Check the ICC steering switch. Refer to [CCS-115. "Component Inspection"](#).

>> GO TO 6.

5. REPLACE ADAS CONTROL UNIT

Replace the ADAS control unit. Refer to [DAS-85. "Removal and Installation"](#).

>> GO TO 6.

6. CHECK ICC SYSTEM

1. Erase the self-diagnosis results, and then perform "All DTC Reading" again after performing the action test. (Refer to [CCS-97. "Description"](#) for action test.)
2. Check that the ICC system is normal.

>> INSPECTION END

ICC SYSTEM DOES NOT CANCEL WHEN CVT SELECTOR LEVER SETS ON "N" [ICC]

< SYMPTOM DIAGNOSIS >

ICC SYSTEM DOES NOT CANCEL WHEN CVT SELECTOR LEVER SETS ON "N"

Description

INFOID:0000000011132225

The ICC system is not canceled even when the CVT selector lever is shifted to the N position while the ICC system is active.

Diagnosis Procedure

INFOID:0000000011132226

1. CHECK D RANGE SWITCH

Check if "D RANGE SW" operates normally in "DATA MONITOR" of "ICC/ADAS" with CONSULT.

Is the inspection result normal?

- YES >> GO TO 6.
- NO >> GO TO 2.

2. PERFORM ALL SELF-DIAGNOSIS ITEMS

1. Perform "All DTC Reading".
2. Check if the "U1000" is detected in "self-diagnosis results" of "ICC/ADAS".

Is "U1000" detected?

- YES >> GO TO 3.
- NO >> GO TO 4.

3. CAN COMMUNICATIONS INSPECTION

Check the CAN communication and repair or replace malfunctioning parts. Refer to [CCS-165, "ADAS CONTROL UNIT : DTC Logic"](#).

>> INSPECTION END

4. CHECK POSITION SWITCH

Check if "SLCT LVR POSI" operates normally in "DATA MONITOR" of "TRANSMISSION".

Is the inspection result normal?

- YES >> GO TO 6.
- NO >> GO TO 5.

5. PERFORM TCM SELF-DIAGNOSIS

1. Perform the "Self Diagnostic Result" of "TRANSMISSION".
2. Repair or replace malfunctioning parts. Refer to [TM-63, "DTC Index"](#) (RE0F10E) or [TM-277, "DTC Index"](#) (RE0F10J).

>> GO TO 7.

6. REPLACE ADAS CONTROL UNIT

Replace the ADAS control unit. Refer to [DAS-85, "Removal and Installation"](#).

>> GO TO 7.

7. CHECK ICC SYSTEM

1. Erase the self-diagnosis results, and then perform "All DTC Reading" again after performing the action test. (Refer to [CCS-97, "Description"](#) for action test.)
2. Check that the ICC system is normal.

>> INSPECTION END

CHIME DOES NOT SOUND

< SYMPTOM DIAGNOSIS >

[ICC]

CHIME DOES NOT SOUND

Description

INFOID:000000011132227

Symptom check: In the following conditions, the warning chime may not sound even if the vehicle distance is short.

- When the vehicles are traveling at the same speed and the distance between vehicles is not changing.
- When the vehicle ahead is traveling faster and the distance between vehicles is increasing.
- The warning chime will not sound when the accelerator pedal is depressed, overriding the system.
- The warning chime will not sound when own vehicle approaches vehicles that are parked or moving slowly.
- The warning chime does not sound when the system does not detect any vehicle ahead. (Diagnose the conditions under which the system is detecting the vehicle ahead and when the system is malfunctioning. If there is any malfunction in detecting the vehicle ahead, check the system following the [CCS-188, "Description"](#).)

Diagnosis Procedure

INFOID:000000011132228

1.PERFORM ACTIVE TEST

Check if the warning chime sounds on the active test item "ICC BUZZER" of "ICC/ADAS" with CONSULT.

Does the warning chime sound?

- YES >> GO TO 2.
- NO >> GO TO 3.

2.CHECK THE MALFUNCTION SYMPTOM DURING WARNING CHIME OPERATION

Understand the vehicle ahead detecting condition when the malfunction occurred. If the warning chime should have sounded, replace the ADAS control unit. Refer to [DAS-85, "Removal and Installation"](#).

>> GO TO 8.

3.CHECK ICC WARNING CHIME CIRCUIT

Check the meter buzzer circuit. Refer to [WCS-29, "Component Function Check"](#).

Is the inspection result normal?

- YES >> GO TO 4.
- NO >> GO TO 6.

4.PERFORM THE SELF-DIAGNOSIS

1. Perform "All DTC Reading" with CONSULT.
2. Check if the "U1000" is detected in self-diagnosis results of "ICC/ADAS".

Is "U1000" detected?

- YES >> GO TO 5.
- NO >> GO TO 7.

5.CAN COMMUNICATIONS SYSTEM INSPECTION

Check the CAN communication system and repair or replace malfunctioning parts. Refer to [CCS-165, "ADAS CONTROL UNIT : DTC Logic"](#).

>> INSPECTION END

6.REPAIR OR REPLACE MALFUNCTIONING PARTS

Repair or replace malfunctioning parts.

>> GO TO 8.

7.REPLACE ADAS CONTROL UNIT

Replace the ADAS control unit. Refer to [DAS-85, "Removal and Installation"](#).

>> GO TO 8.

A
B
C
D
E
F
G
H
I
J
K
L
M
N
P

CCS

CHIME DOES NOT SOUND

< SYMPTOM DIAGNOSIS >

[ICC]

8. CHECK ICC SYSTEM

1. Erase the self-diagnosis results, and then perform "All DTC Reading" again after performing the action test. (Refer to [CCS-97, "Description"](#) for action test.)
2. Check that the ICC system is normal.

>> INSPECTION END

DRIVING FORCE IS HUNTING

< SYMPTOM DIAGNOSIS >

[ICC]

DRIVING FORCE IS HUNTING

Description

INFOID:0000000011132229

The vehicle causes hunting when the ICC system is active.

Diagnosis Procedure

INFOID:0000000011132230

1.PERFORM SELF-DIAGNOSIS OF ECM

1. Perform "All DTC Reading" with CONSULT.
2. Check if the DTC is detected in self-diagnosis results of "ENGINE". Refer to [EC-112. "DTC Index"](#) (except for Mexico) or [EC-636. "DTC Index"](#) (for Mexico).

Is any DTC detected?

- YES >> GO TO 3.
NO >> GO TO 2.

2.CHECK ICC SENSOR

1. Check the vehicle driving conditions. Refer to [CCS-188. "Description"](#).
2. Check the ICC sensor for contamination, foreign materials, or cracks. Refer to [CCS-188. "Diagnosis Procedure"](#).

>> INSPECTION END

3.REPAIR OR REPLACE MALFUNCTIONING PARTS

Repair or replace malfunctioning parts identified by the self-diagnosis result.

>> GO TO 4.

4.CHECK ICC SYSTEM

1. Erase the self-diagnosis results, and then perform "All DTC Reading" again after performing the action test. (Refer to [CCS-97. "Description"](#) for action test.)
2. Check that the ICC system is normal.

>> INSPECTION END

A
B
C
D
E
F
G
H
I
J
K
L
M
N
P

CCS

FREQUENTLY CANNOT DETECT THE VEHICLE AHEAD / DETECTION ZONE IS SHORT

< SYMPTOM DIAGNOSIS >

[ICC]

FREQUENTLY CANNOT DETECT THE VEHICLE AHEAD / DETECTION ZONE IS SHORT

Description

INFOID:0000000011132231

The detection function may become unstable in the following cases.

- When radar reflections from the vehicle ahead is interrupted.
- When driving a road with extremely sharp corners.
- When the sensor cannot detect a vehicle ahead while the vehicle ahead passes a hill or valley.

Diagnosis Procedure

INFOID:0000000011132232

1.VISUAL CHECK (1)

Check the contamination and foreign matter on the ICC sensor area of the front bumper.

Do foreign matter adhere?

- YES >> GO TO 3.
- NO >> GO TO 2.

2.VISUAL CHECK (2)

1. Remove the front bumper. Refer to [EXT-17, "Removal and Installation"](#).
2. Check ICC sensor for contamination and foreign matter.

Do foreign matter adhere?

- YES >> GO TO 3.
- NO >> GO TO 4.

3.WIPE OUT DIRT AND FOREIGN MATERIALS

Wipe out the contamination and foreign matter in the area around the ICC sensor.

>> GO TO 8.

4.VISUAL CHECK (3)

Check ICC sensor for cracks and scratches.

Are there any cracks or scratches?

- YES >> GO TO 6.
- NO >> GO TO 5.

5.ADJUST RADAR ALIGNMENT

1. Install the front bumper. Refer to [EXT-17, "Removal and Installation"](#).
2. Adjust the radar alignment. Refer to [CCS-89, "Description"](#).
3. Perform ICC system action test. Refer to [CCS-97, "Description"](#).
4. Check that the vehicle ahead detection performance improves.

Does it improve?

- YES >> INSPECTION END
- NO >> GO TO 6.

6.REPLACE ICC SENSOR

1. Replace the ICC sensor. Refer to [CCS-195, "Removal and Installation"](#).
2. Install the front bumper. Refer to [EXT-17, "Removal and Installation"](#).
3. Adjust the radar alignment. Refer to [CCS-89, "Description"](#).
4. Perform ICC system action test. Refer to [CCS-97, "Description"](#).
5. Check that the vehicle ahead detection performance improves.

Does it improve?

- YES >> INSPECTION END
- NO >> GO TO 7.

7.REPLACE ADAS CONTROL UNIT

Replace ADAS control unit. Refer to [DAS-85, "Removal and Installation"](#).

FREQUENTLY CANNOT DETECT THE VEHICLE AHEAD / DETECTION ZONE IS SHORT

< SYMPTOM DIAGNOSIS >

[ICC]

>> GO TO 8.

8. CHECK ICC SYSTEM

1. Erase the self-diagnosis results, and then perform "All DTC Reading" again after performing the action test. (Refer to [CCS-97. "Description"](#) for action test.)
2. Check that the ICC system is normal.

>> INSPECTION END

A

B

C

D

E

F

G

H

I

J

K

L

M

N

CCS

P

THE SYSTEM DOES NOT DETECT THE VEHICLE AHEAD AT ALL

< SYMPTOM DIAGNOSIS >

[ICC]

THE SYSTEM DOES NOT DETECT THE VEHICLE AHEAD AT ALL

Description

INFOID:000000011132233

When ICC system is active, the ICC system does not perform any control even through there is a vehicle ahead.

Diagnosis Procedure

INFOID:000000011132234

1. CHECK ICC SYSTEM DISPLAY ON INFORMATION DISPLAY

1. Start the self-diagnosis mode of combination meter. Refer to [MWI-17, "Description"](#).
2. Check that the information display turns ON normally.

Is the inspection result normal?

- YES >> GO TO 2.
- NO >> Replace the combination meter.

2. VISUAL CHECK (1)

Check the contamination and foreign matter on the ICC sensor area of the front bumper.

Do foreign matter adhere?

- YES >> GO TO 4.
- NO >> GO TO 3.

3. VISUAL CHECK (2)

1. Remove the front bumper. Refer to [EXT-17, "Removal and Installation"](#).
2. Check ICC sensor for contamination and foreign matter.

Do foreign matter adhere?

- YES >> GO TO 4.
- NO >> GO TO 5.

4. WIPE OUT DIRT AND FOREIGN MATTER

Wipe out the contamination and foreign matter in the area around the ICC sensor.

>> GO TO 9.

5. VISUAL CHECK (3)

Check ICC sensor for cracks and/or scratches.

Are there cracks?

- YES >> GO TO 7.
- NO >> GO TO 6.

6. RADAR ALIGNMENT ADJUSTMENT

1. Install the front bumper. Refer to [EXT-17, "Removal and Installation"](#).
2. Adjust the radar alignment. Refer to [CCS-89, "Description"](#).
3. Perform ICC system action test. Refer to [CCS-97, "Description"](#).
4. Check that the vehicle ahead detection performance improves.

Does it improve?

- YES >> INSPECTION END
- NO >> GO TO 8.

7. REPLACE ICC SENSOR

1. Replace the ICC sensor. Refer to [CCS-195, "Removal and Installation"](#).
2. Install the front bumper. Refer to [EXT-17, "Removal and Installation"](#).
3. Adjust the radar alignment. Refer to [CCS-89, "Description"](#).
4. Perform ICC system action test. Refer to [CCS-97, "Description"](#).
5. Check that the vehicle ahead detection performance improves.

Does it improve?

- YES >> INSPECTION END

THE SYSTEM DOES NOT DETECT THE VEHICLE AHEAD AT ALL

< SYMPTOM DIAGNOSIS >

[ICC]

NO >> GO TO 8.

8.REPLACE ADAS CONTROL UNIT

Replace ADAS control unit. Refer to [DAS-85, "Removal and Installation"](#).

>> GO TO 9.

9.CHECK ICC SYSTEM

1. Erase the self-diagnosis results, and then perform "All DTC Reading" again after performing the action test. (Refer to [CCS-97, "Description"](#) for action test.)
2. Check that the ICC system is normal.

>> INSPECTION END

A
B
C
D
E
F
G
H
I
J
K
L
M
N
P

CCS

NORMAL OPERATING CONDITION

Description

INFOID:000000011132235

PRECAUTIONS FOR VEHICLE-TO-VEHICLE DISTANCE CONTROL MODE

- ICC system is only an aid to assist the driver and is not a collision warning or avoidance system. It is the driver's responsibility to stay alert, drive safely and be in control of the vehicle at all times.
- The system is primarily intended for use on straight, dry, open roads with light traffic. It is not advisable to use the system in city traffic or congested areas.
- This system will not adapt automatically to road conditions. This system should be used in evenly flowing traffic. Never use the system on roads with sharp curves, or on icy roads, in heavy rain or in fog.
- The ICC sensor will not detect the following objects:
 - Stationary and slow moving vehicles.
 - Pedestrians or objects in the roadway.
 - Oncoming vehicles in the some lane.
 - Motorcycles traveling offset in the travel lane.
- As there is a performance limit to the distance control function, never rely solely on the ICC system. This system does not correct careless, inattentive or absent-minded driving, or overcome poor visibility in rain, fog, or other bad weather. Decelerate the vehicle speed by depressing the brake pedal, depending on the distance to the vehicle ahead and the surrounding circumstances in order to maintain a safe distance between vehicles.
- If the vehicle ahead comes to a stop, the vehicle decelerates to a standstill within the limitations of the system. The system will cancel once it judges that the vehicle has come to a standstill and sound a warning chime. To prevent the vehicle from moving, the driver must depress the brake pedal.
- The system may not detect the vehicle in front of the driver in certain road or weather conditions. To avoid accidents, never use the ICC system under the following conditions:
 - On roads where the traffic is heavy or there are sharp curves.
 - On slippery road surfaces such as on ice or snow, etc.
 - During bad weather (rain, fog, snow, etc.)
 - When rain, snow or dirt adhere to the ICC sensor.
 - On steep downhill roads (the vehicle may go beyond the set vehicle speed and frequent braking may result in overheating the brakes).
 - On repeated uphill and downhill roads.
 - When traffic conditions make it difficult to keep a proper distance between vehicles because of frequent acceleration or deceleration.
- Never use the ICC system if own vehicle is towing a trailer. The system may not detect a vehicle ahead.
- In some road or traffic conditions, a vehicle or object can unexpectedly come into the sensor detection zone and cause automatic braking. The driver may need to control the distance from other vehicles using the accelerator pedal. Always stay alert and avoid using the ICC system when it is not recommended in this section.
- The vehicle-to-vehicle distance control mode uses a sensor located behind the front bumper of the vehicle to detect vehicles traveling ahead. The sensor generally detects the signals returned from the vehicle ahead. Therefore, if the sensor cannot detect the reflection from the vehicle ahead, the ICC system may not maintain the selected distance.
- The following are some conditions in which the sensor cannot detect the signals:
 - When the snow or road spray from traveling vehicles reduces the sensor's visibility.
 - When excessively heavy baggage is loaded in the rear seat or the luggage room of own vehicle.
- The ICC system is designed to automatically check the sensor's operation within the limitation of the system. When the front bumper area of the ICC sensor is covered with dirt or is obstructed, the system will automatically cancel. If the front bumper area of the ICC sensor is covered with ice, a transparent or translucent vinyl bag, etc., the ICC system may not detect them. In these instances, the vehicle-to-vehicle distance control mode may not cancel and may not be able to maintain the selected following distance from the vehicle ahead. Be sure to check and clean the front bumper area of the ICC sensor regularly.
- The ICC system does not control vehicle speed or warn the driver when own vehicle approaches stationary and slow moving vehicles. The driver must pay attention to vehicle operation to maintain proper distance from vehicles ahead when approaching toll gates or traffic congestion.

NORMAL OPERATING CONDITION

[ICC]

< SYMPTOM DIAGNOSIS >

- The detection zone of the ICC sensor is limited. A vehicle ahead must be in the detection zone for the vehicle-to-vehicle distance detection mode to maintain the selected distance from the vehicle ahead. A vehicle ahead may move outside of the detection zone due to its position within the same lane of travel. Motorcycles may not be detected in the same lane ahead if they are traveling offset from the center line of the lane. A vehicle that is entering the lane ahead may not be detected until the vehicle has completely moved into the lane. If this occurs, the ICC system may warn the driver by blinking the system indicator and sounding the chime. The driver may have to manually control the proper distance away from vehicle traveling ahead.

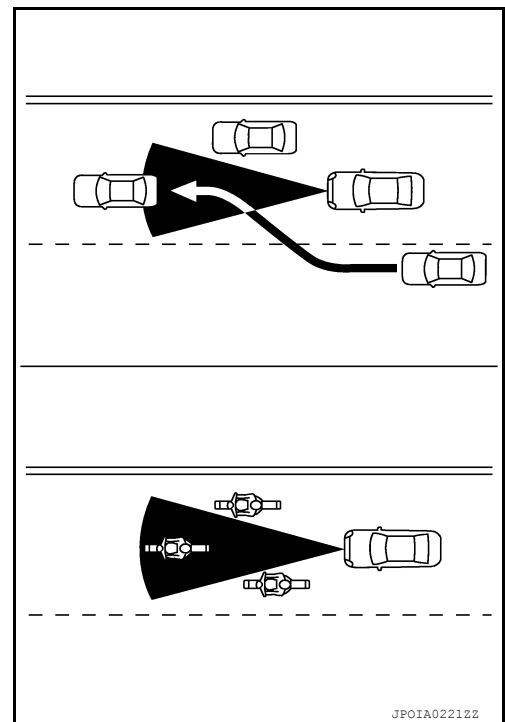

- When driving on some roads, such as winding, hilly, curved, narrow roads, or roads which are under construction, the ICC sensor may detect vehicles in a different lane, or may temporarily not detect a vehicle traveling ahead. This may cause the ICC system to decelerate or accelerate the vehicle. The detection of vehicles may also be affected by vehicle operation (steering maneuver or traveling position in the lane, etc.) or vehicle condition. If this occurs, the ICC system may warn the driver by blinking the system indicator and sounding the chime unexpectedly. The driver will have to manually control the proper distance away from the vehicle traveling ahead.

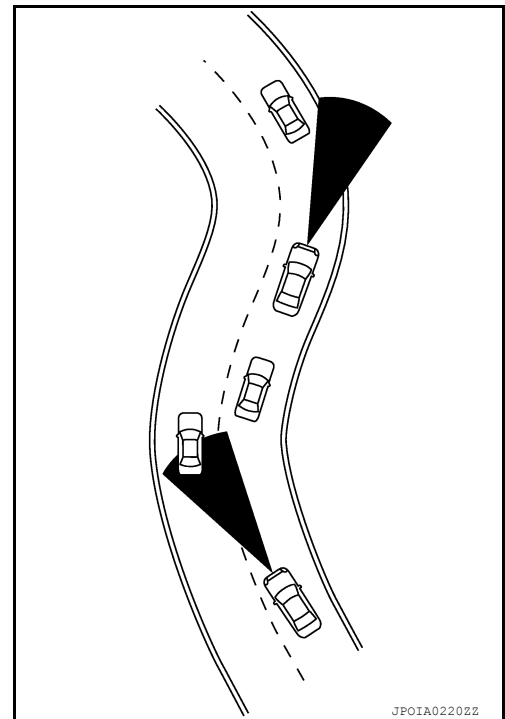

- When driving on the freeway at a set speed and approaching a slower traveling vehicle ahead, the ICC will adjust the speed to maintain the distance, selected by the driver, from the vehicle ahead. If the vehicle ahead changes lanes or exits the freeway, the ICC system will accelerate and maintain the speed up to the set speed. Pay attention to the driving operation to maintain control of the vehicle as it accelerates to the set speed. The vehicle may not maintain the set speed on winding or hilly roads. If this occurs, the driver will have to manually control the vehicle speed.

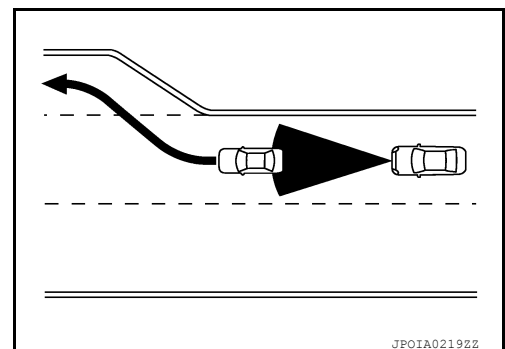

A
B
C
D
E
F
G
H
I
J
K
L
M
N

CCS

P

NORMAL OPERATING CONDITION

< SYMPTOM DIAGNOSIS >

[ICC]

- Normally when controlling the distance to a vehicle ahead, this system automatically accelerates or decelerates own vehicle according to the speed of the vehicle ahead. Depress the accelerator to properly accelerate own vehicle when acceleration is required for a lane change. Depress the brake pedal when deceleration is required to maintain a safe distance to the vehicle ahead due to its sudden braking or if a vehicle cuts in. Always stay alert when using the ICC system.
- The sensor sensitivity can be affected by vehicle operation (steering maneuver or driving position in the lane) or traffic or vehicle condition (for example, if a vehicle is being driven with some damage).

PRECAUTIONS FOR CONVENTIONAL (FIXED SPEED) CRUISE CONTROL MODE

- In the conventional (fixed speed) cruise control mode, a warning chime does not sound to warn the driver if own vehicle is too close to the vehicle ahead, as neither the presence of the vehicle ahead nor the vehicle-to-vehicle distance is detected.
- Pay special attention to the distance between own vehicle and the vehicle ahead or a collision could occur.
- Always confirm the setting in the ICC system display.
- Never use the conventional (fixed speed) cruise control mode when driving under the following conditions:
 - When it is not possible to keep the vehicle at a set speed.
 - In heavy traffic or in traffic that varies in speed.
 - On winding or hilly roads.
 - On slippery roads (rain, snow, ice, etc.).
 - In very windy areas.
- Doing so could cause a loss of vehicle control and result in an accident.
- To avoid accidentally engaging cruise control, make sure to the MAIN switch OFF when not using ICC system.

ICC SENSOR

< REMOVAL AND INSTALLATION >

[ICC]

REMOVAL AND INSTALLATION

ICC SENSOR

Exploded View

INFOID:000000011132236

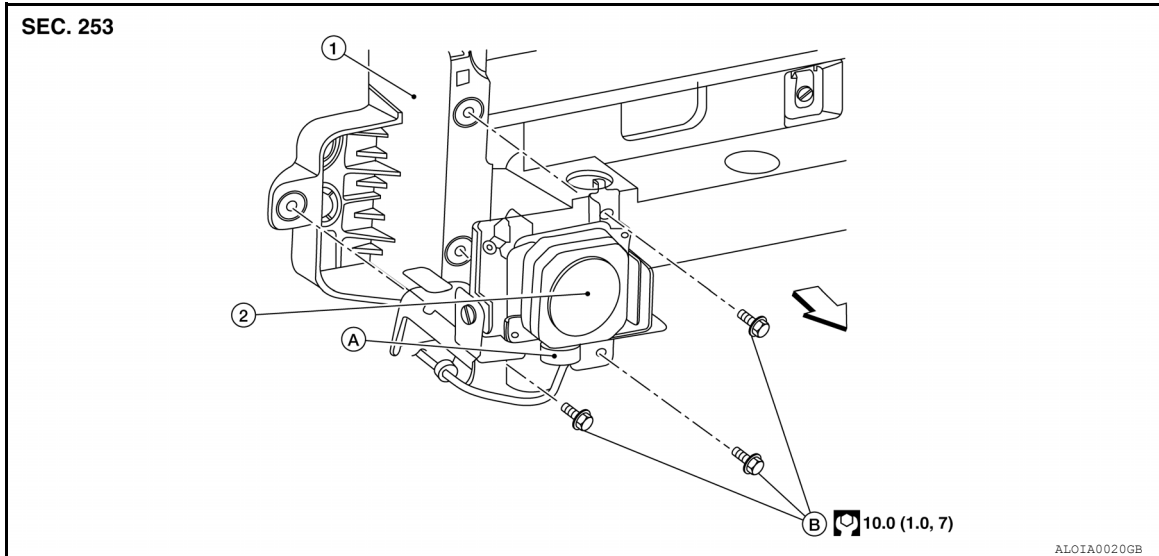

1. Radiator core support assembly 2. ICC sensor ← Front
A. ICC sensor harness connector B. For tightening sequence, refer to [CCS-195, "Removal and Installation"](#).

Removal and Installation

INFOID:000000011132237

REMOVAL

1. Remove front bumper fascia. Refer to [EXT-17, "Removal and Installation"](#).
2. Disconnect the harness connector from the ICC sensor.
3. Release the harness clip from the ICC sensor.
4. Remove ICC sensor bolts.
5. Remove ICC sensor.

INSTALLATION

Installation is in the reverse order of removal.

- Install ICC sensor bolts (←) loosely, then tighten in sequence shown.

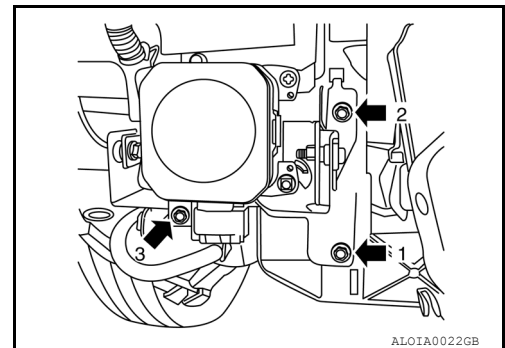

CAUTION:

- Always perform the ICC sensor alignment and check the operation after removal, installation or replacement of ICC sensor. Refer to [CCS-85, "Work Procedure"](#).
- Do not drop or shock ICC sensor.

ICC SENSOR

< REMOVAL AND INSTALLATION >

[ICC]

- **Make sure ICC sensor harness is installed without any twists.**

ICC STEERING SWITCH

< REMOVAL AND INSTALLATION >

[ICC]

ICC STEERING SWITCH

Exploded View

INFOID:000000011132238

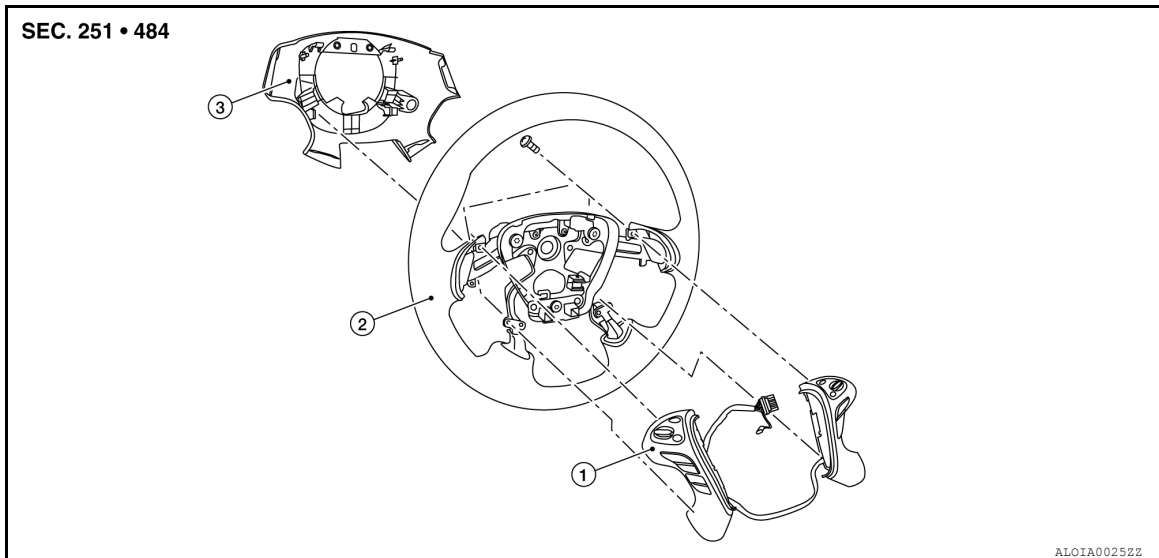

1. ICC steering switch

2. Steering wheel

3. Steering wheel rear finisher

Removal and Installation

INFOID:000000011132239

REMOVAL

NOTE:

The ICC steering and audio switches are serviced as an assembly.

1. Remove steering wheel. Refer to [ST-47. "Removal and Installation"](#).
2. Release pawls (←) and remove steering wheel rear finisher (1) from steering wheel (2).

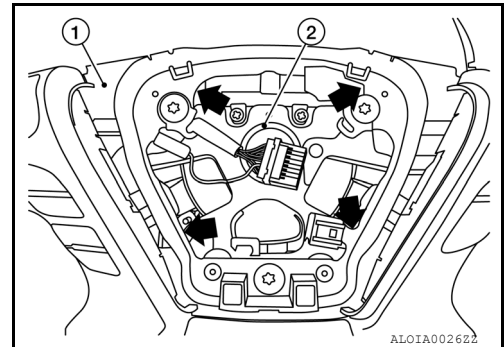

3. Remove ICC steering and audio switch assembly screws (←).
4. Remove ICC steering and audio switch assembly (1) from steering wheel (2).

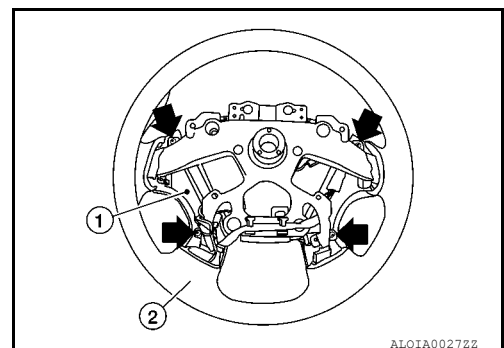

INSTALLATION

Installation is in the reverse order of removal.

A
B
C
D
E
F
G
H
I
J
K
L
M
N
P

CCS

ICC STEERING SWITCH

< REMOVAL AND INSTALLATION >

[ICC]

CAUTION:

Always perform the ICC system action test to check that the ICC system operates normally after replacing the ICC sensor or repairing any ICC system malfunction. Refer to [CCS-97, "Work Procedure \(Vehicle-To-Vehicle Distance Control Mode\)"](#).

PRECAUTION

PRECAUTIONS

Precaution for Supplemental Restraint System (SRS) "AIR BAG" and "SEAT BELT PRE-TENSIONER"

INFOID:000000011132240

The Supplemental Restraint System such as "AIR BAG" and "SEAT BELT PRE-TENSIONER", used along with a front seat belt, helps to reduce the risk or severity of injury to the driver and front passenger for certain types of collision. This system includes dual stage front air bag modules. The SRS system may only deploy one front air bag, depending on the severity of a collision and whether the front passenger seat is occupied. Information necessary to service the system safely is included in the SR and SB section of this Service Manual.

WARNING:

- To avoid rendering the SRS inoperative, which could increase the risk of personal injury or death in the event of a collision which would result in air bag inflation, all maintenance must be performed by an authorized NISSAN/INFINITI dealer.
- Improper maintenance, including incorrect removal and installation of the SRS, can lead to personal injury caused by unintentional activation of the system. For removal of Spiral Cable and Air Bag Module, see the SR section.
- Do not use electrical test equipment on any circuit related to the SRS unless instructed to in this Service Manual. SRS wiring harnesses can be identified by yellow and/or orange harnesses or harness connectors.

PRECAUTIONS WHEN USING POWER TOOLS (AIR OR ELECTRIC) AND HAMMERS

WARNING:

- When working near the Airbag Diagnosis Sensor Unit or other Airbag System sensors with the Ignition ON or engine running, DO NOT use air or electric power tools or strike near the sensor(s) with a hammer. Heavy vibration could activate the sensor(s) and deploy the air bag(s), possibly causing serious injury.
- When using air or electric power tools or hammers, always switch the Ignition OFF, disconnect the battery and wait at least three minutes before performing any service.

A
B
C
D
E
F
G
H
I
J
K
L
M
N
P



AUTOMATIC SPEED CONTROL DEVICE (ASCD)

< SYSTEM DESCRIPTION >

[ASCD]

SYSTEM DESCRIPTION

AUTOMATIC SPEED CONTROL DEVICE (ASCD)

Information

INFOID:000000011132241

Automatic Speed Control Device (ASCD) system is controlled by ECM.

Regarding the information for ASCD system, refer to following;

- VQ35DE: [EC-49. "AUTOMATIC SPEED CONTROL DEVICE \(ASCD\) : System Description"](#) (except for Mexico)
- VQ35DE: [EC-579. "AUTOMATIC SPEED CONTROL DEVICE \(ASCD\) : System Description"](#) (for Mexico)