

SECTION **BRM**  
BODY REPAIR

A  
B  
C  
D  
E  
F  
G  
H  
I  
J  
K  
L  
M  
N  
O  
P

CONTENTS

<b>VEHICLE INFORMATION</b> .....	2	<b>BODY SEALING</b> .....	20
<b>BODY EXTERIOR PAINT COLOR</b> .....	2	Description .....	20
Body Exterior Paint Color .....	2	<b>BODY CONSTRUCTION</b> .....	23
<b>PRECAUTION</b> .....	3	Body Construction .....	23
<b>PRECAUTIONS</b> .....	3	<b>REPLACEMENT OPERATIONS</b> .....	25
Precautions for Body Repair .....	3	Precautions for Body Repair .....	25
Precaution for Supplemental Restraint System (SRS) "AIR BAG" and "SEAT BELT PRE-TEN- SIONER" .....	3	Description .....	25
<b>HANDLING PRECAUTIONS FOR PLASTICS</b> ....	4	Hoodledge .....	28
Precautions For Plastics .....	4	Front Side Member (Partial Replacement) .....	28
<b>REPAIRING HIGH STRENGTH STEEL</b> .....	8	Front Pillar .....	29
High Strength Steel (HSS) .....	8	Dash Side .....	32
Handling of Ultra High Strength Steel Plate Parts...	10	Center Pillar .....	33
<b>PREPARATION</b> .....	11	Outer Sill Reinforcement .....	35
<b>REPAIRING MATERIAL</b> .....	11	Rear Fender .....	37
Foam Repair .....	11	Rear Body Side Inner Assembly .....	37
<b>BODY COMPONENT PARTS</b> .....	13	Rear Floor Rear .....	38
Underbody Component Parts .....	13	Rear Panel Assembly .....	41
Body Component Parts .....	15	Roof .....	42
<b>REMOVAL AND INSTALLATION</b> .....	17	Rear Side Member Extension .....	42
<b>CORROSION PROTECTION</b> .....	17	<b>SERVICE DATA AND SPECIFICATIONS (SDS)</b> .....	44
Description .....	17	<b>BODY ALIGNMENT</b> .....	44
Anti-Corrosive Wax .....	17	Body Center Marks .....	44
Undercoating .....	18	Description .....	45
		Engine Compartment .....	45
		Underbody .....	48
		Passenger Compartment .....	52
		Rear Body .....	54

BRM

# BODY EXTERIOR PAINT COLOR

< VEHICLE INFORMATION >

## VEHICLE INFORMATION

### BODY EXTERIOR PAINT COLOR

Body Exterior Paint Color

INFOID:000000012852544

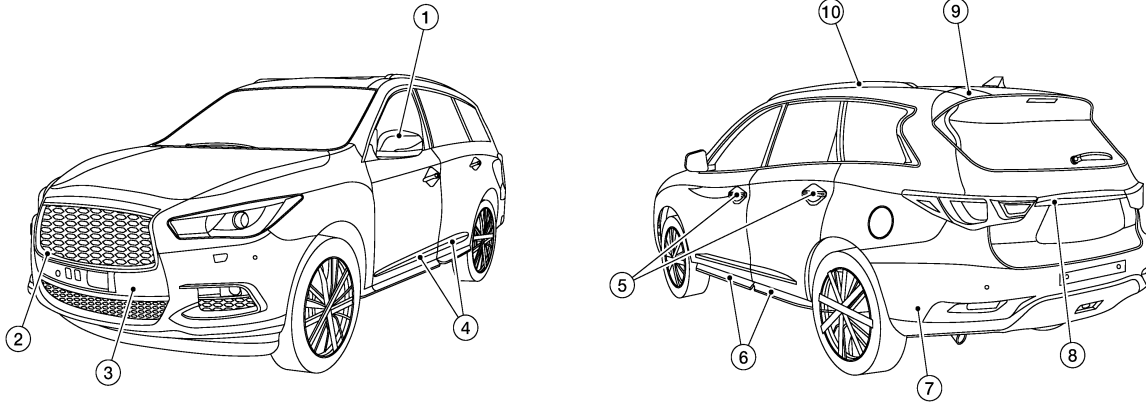

ALKIA4325ZZ

Component			Color code	JAK	BW5	K23	KAD	KH3	QAB	RBP
			Description	Green	Blue	Silver	Gray	Black	White	Grayish Blue
			Paint type	M	P	M	M	S	3P	M
			Hard clear coat	t	t	t	t	t	t	t
1	Door mirror	Base	Black	KH3	KH3	KH3	KH3	KH3	KH3	KH3
		Housing	Body color	JAK	BW5	K23	KAD	KH3	QAB	RBP
2	Front grille		Chromium Plate	Cr2P	Cr2P	Cr2P	Cr2P	Cr2P	Cr2P	Cr2P
3	Front bumper fascia		Body color	JAK	BW5	K23	KAD	KH3	QAB	RBP
4	Side guard molding		Chromium Plate	Cr2P	Cr2P	Cr2P	Cr2P	Cr2P	Cr2P	Cr2P
5	Door outside handle		Chromium Plate	Cr2P	Cr2P	Cr2P	Cr2P	Cr2P	Cr2P	Cr2P
6	Sill molding		Black	KH3	KH3	KH3	KH3	KH3	KH3	KH3
7	Rear bumper fascia		Body color	JAK	BW5	K23	KAD	KH3	QAB	RBP
8	Back door outer finisher		Chromium Plate	Cr2P	Cr2P	Cr2P	Cr2P	Cr2P	Cr2P	Cr2P
9	Rear spoiler		Body color	JAK	BW5	K23	KAD	KH3	QAB	RBP
10	Roof side molding		Body color	JAK	BW5	K23	KAD	KH3	QAB	RBP

M= Metallic, S= Solid, P = Pearl, Black is solvent based, all others are water based, t = TMAC clear coat, 3P = 3-Coat Pearl

# PRECAUTIONS

< PRECAUTION >

## PRECAUTION

### PRECAUTIONS

#### Precautions for Body Repair

INFOID:000000013509557

##### **WARNING:**

- The repair information in this section is intended for trained body repair technicians who have attained a high level of skill and experience (e.g. ASE Collision Repair Certification, I-CAR Professional Development Program [PDP] training, etc.) in repairing collision damaged vehicles using appropriate tools and equipment. Performing repairs without the proper training, tools or equipment could damage the vehicle or cause personal injury or death to you or others.
- The information in this Body Repair Manual is a guideline for repairing collision damaged vehicles. However, this information cannot cover all possible ways that a vehicle can be damaged. As such, the body repair technician is responsible for making sure that the repair does not affect the structural integrity or safety of the vehicle. Improper repair of a damaged vehicle may result in a collision, property damage, personal injury or death.
- Infiniti recommends using only new genuine Infiniti replacement body parts. Use of used, salvaged or aftermarket body parts is not recommended by Infiniti. Non-genuine Infiniti components may affect the vehicle's structural integrity and crash safety performance, which could result in serious personal injury or death in an accident.

#### Precaution for Supplemental Restraint System (SRS) "AIR BAG" and "SEAT BELT PRE-TENSIONER"

INFOID:000000013521710

The Supplemental Restraint System such as "AIR BAG" and "SEAT BELT PRE-TENSIONER", used along with a front seat belt, helps to reduce the risk or severity of injury to the driver and front passenger for certain types of collision. This system includes dual stage front air bag modules. The SRS system may only deploy one front air bag, depending on the severity of a collision and whether the front passenger seat is occupied. Information necessary to service the system safely is included in the SR and SB section of this Service Manual.

##### **WARNING:**

- To avoid rendering the SRS inoperative, which could increase the risk of personal injury or death in the event of a collision which would result in air bag inflation, it is recommended that all maintenance and repair be performed by an authorized NISSAN/INFINITI dealer.
- Improper repair, including incorrect removal and installation of the SRS, can lead to personal injury caused by unintentional activation of the system. For removal of Spiral Cable and Air Bag Module, see the SR section.
- Do not use electrical test equipment on any circuit related to the SRS unless instructed to in this Service Manual. SRS wiring harnesses can be identified by yellow and/or orange harnesses or harness connectors.

#### PRECAUTIONS WHEN USING POWER TOOLS (AIR OR ELECTRIC) AND HAMMERS

##### **WARNING:**

- When working near the Air Bag Diagnosis Sensor Unit or other Air Bag System sensors with the Ignition ON or engine running, DO NOT use air or electric power tools or strike near the sensor(s) with a hammer. Heavy vibration could activate the sensor(s) and deploy the air bag(s), possibly causing serious injury.
- When using air or electric power tools or hammers, always switch the Ignition OFF, disconnect the battery or batteries, and wait at least three minutes before performing any service.

A  
B  
C  
D  
E  
F  
G  
H  
I  
J  
BRM  
L  
M  
N  
O  
P

# HANDLING PRECAUTIONS FOR PLASTICS

< PRECAUTION >

## HANDLING PRECAUTIONS FOR PLASTICS

### Precautions For Plastics

INFOID:000000012852546

Abbreviation	Material name	Heatresisting temperature °C (°F)	Resistance to gasoline and solvents	Other cautions
PE	Polyethylene	60(140)	Gasoline and most solvents are harmless if applied for a very short time (wipe up quickly).	Flammable
PVC	Poly Vinyl Chloride	80(176)	Same as above.	Poison gas is emitted when burned.
EPM/EPDM	Ethylene Propylene (Diene) copolymer	80(176)	Same as above.	Flammable
TPO/TPR	Thermoplastic Olefine/ Thermoplastic rubber	80(176)	Same as above.	Flammable
PP	Polypropylene	90(194)	Same as above.	Flammable, avoid battery acid.
UP	Unsaturated Polyester	90(194)	Same as above.	Flammable
PS	Polystyrene	80(176)	Avoid solvents.	Flammable
ABS	Acrylonitrile Butadiene Styrene	80(176)	Avoid gasoline and solvents.	—
PMMA	Poly Methyl Methacrylate	85(185)	Same as above.	—
EVAC	Ethylene Vinyl Acetate	90(194)	Same as above.	—
ASA	Acrylonitrile Styrene Acrylate	100(222)	Same as above.	Flammable
PPE	Poly Phenylene Ether	110(230)	Same as above.	—
PC	Polycarbonate	120(248)	Same as above.	—
PAR	Polyarylate	180(356)	Same as above.	—
PUR	Polyurethane	90(194)	Same as above.	—
PPC	Polypropylene Composite	115 (239)	Same as above	Flammable
POM	Poly Oxymethylene	120(248)	Same as above.	Avoid battery acid.
PBT+PC	Poly Butylene Terephthalate + Polycarbonate	120(248)	Same as above.	Flammable
PA	Polyamide (Nylon)	140(284)	Same as above.	Avoid immersing in water.
PBT	Poly Butylene Terephthalate	140(284)	Same as above.	—
PET	Polyester	180(356)	Same as above.	—
PEI	Polyetherimide	200(392)	Same as above.	—

1. When repairing and painting a portion of the body adjacent to plastic parts, consider their characteristics (influence of heat and solvent) and remove them if necessary or take suitable measures to protect them.
2. Plastic parts should be repaired and painted using methods suiting the materials' characteristics.



# HANDLING PRECAUTIONS FOR PLASTICS

< PRECAUTION >

## LOCATION OF PLASTIC PARTS

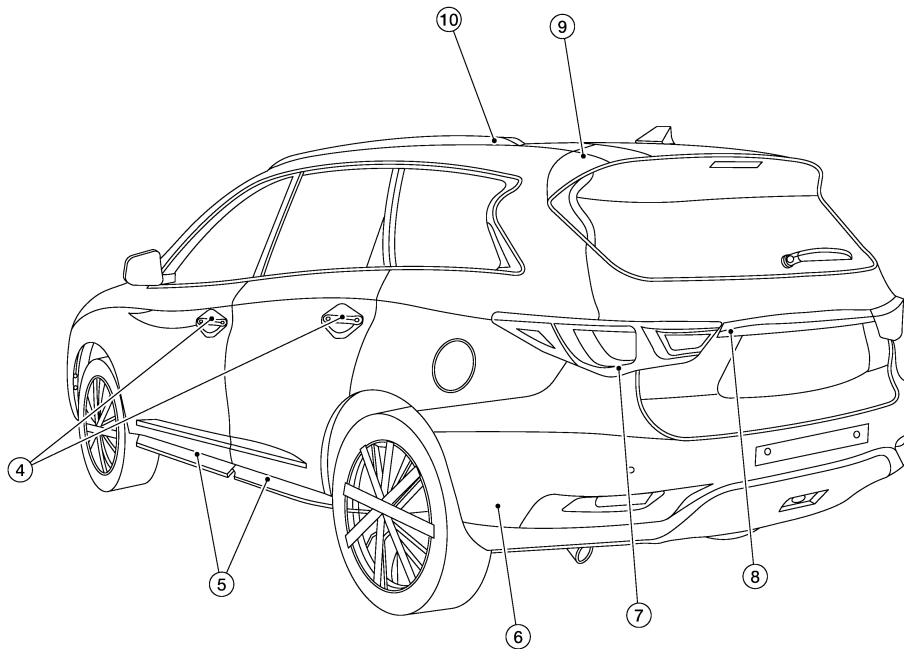
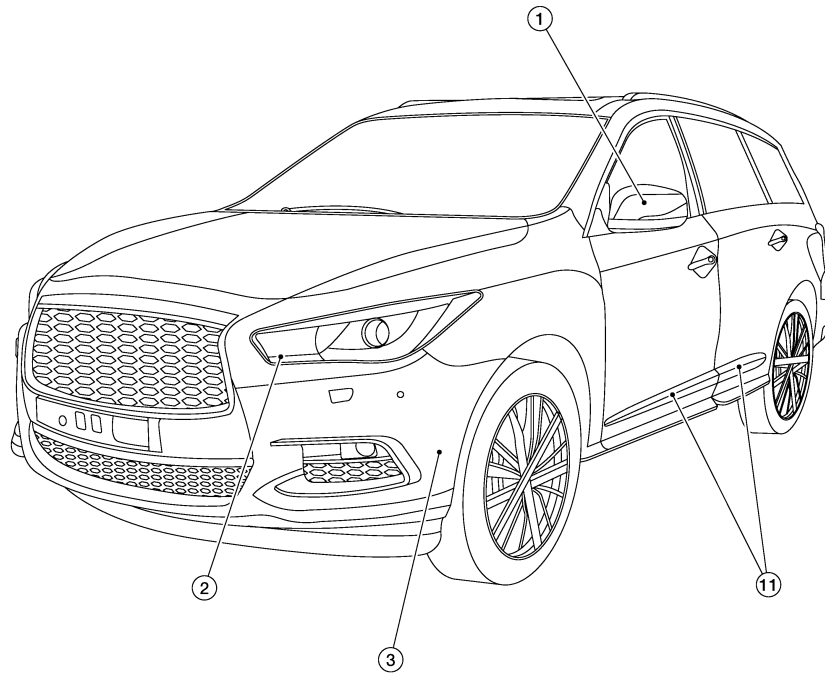

ALKIA4326ZZ

Item	Component	Abbreviation	Material
1.	Door mirror	Base	ABS Acrylonitrile Butadiene Styrene
		Housing	ABS Acrylonitrile Butadiene Styrene
2.	Front combination lamp	Lens	PC Polycarbonate
		Housing	PP Polypropylene

A  
B  
C  
D  
E  
F  
G  
H  
I  
J  
BRM  
L  
M  
N  
O  
P

# HANDLING PRECAUTIONS FOR PLASTICS

## < PRECAUTION >

Item	Component	Abbreviation	Material	
3.	Front bumper fascia	PP + EPM	Polypropylene + Ethylene Propylene (Diene) copolymer	
4.	Door outside handle	Grip	PC	Polycarbonate
		Escutcheon	PA	Polyamide (Nylon)
5.	Sill molding	TPO	Thermoplastic Olefine	
6.	Rear bumper fascia	PP + EPM	Polypropylene + Ethylene Propylene (Diene) copolymer	
7.	Rear combination lamp	Lens	PMMA	Poly Methyl Methacrylate
		Housing	ASA	Acrylonitrile Styrene Acrylate
8.	Back door outer finisher (upper/lower)	ABS + ASA	Acrylonitrile Butadiene Styrene + Acrylonitrile Styrene Acrylate	
9.	Rear spoiler	ABS + PC	Acrylonitrile Butadiene Styrene + Polycarbonate	
10.	Roof side molding	ABS + PC	Acrylonitrile Butadiene Styrene + Polycarbonate	
11.	Body side molding	PVC	Poly Vinyl Chloride	

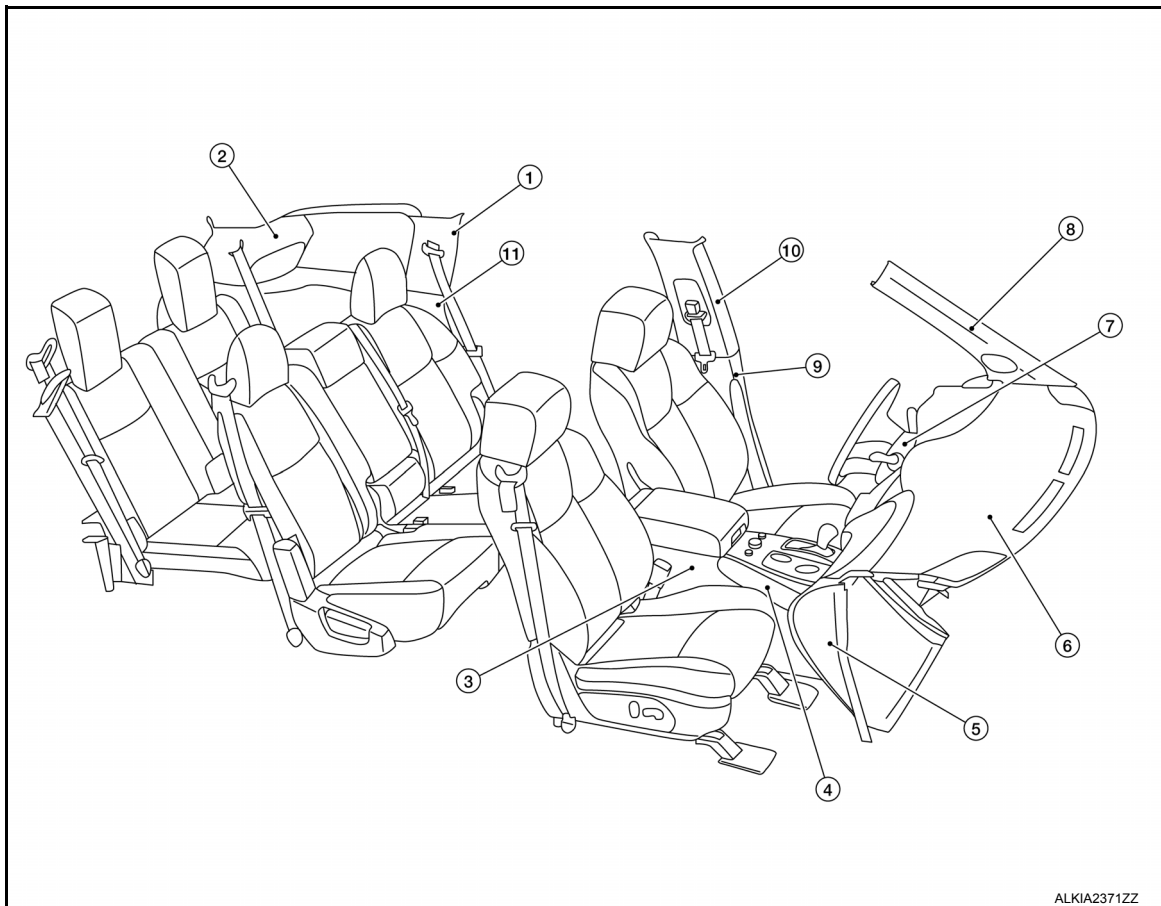

Item	Component	Abbreviation	Material	
1.	Rear pillar finisher	PP	Polypropylene	
2.	Back pillar finisher	PP	Polypropylene	
3.	Center console assembly	Base	PP + EPDM	Polypropylene + Ethylene Propylene (Diene) copolymer
		Box	ABS + PC	Acrylonitrile Butadiene Styrene + Polycarbonate
4.	Shift selector finisher	ABS + PC	Acrylonitrile Butadiene Styrene + Polycarbonate	
5.	Instrument panel side finisher	PP + EPDM	Polypropylene + Ethylene Propylene (Diene) copolymer	

# HANDLING PRECAUTIONS FOR PLASTICS

< PRECAUTION >

Item	Component	Abbreviation	Material
6.	Instrument panel	Base	TPU Thermoplastic Polyurethane
		Skin	PET Polyester
7.	Steering column covers	PP	Polypropylene
8.	Front pillar finisher	Core	PP Polypropylene
		Skin	PET Polyester
9.	Center pillar lower finisher	Core	PP Polypropylene
		Skin	PET Polyester
10.	Center pillar upper finisher	Core	PP Polypropylene
11.	Luggage side finisher	PP	Polypropylene

A  
B  
C  
D  
E  
F  
G  
H  
I  
J  
L  
M  
N  
O  
P

**BRM**

# REPAIRING HIGH STRENGTH STEEL

< PRECAUTION >

## REPAIRING HIGH STRENGTH STEEL

### High Strength Steel (HSS)

INFOID:000000012852547

High strength steel is used for body panels in order to reduce vehicle weight.

Accordingly, precautions in repairing automotive bodies made of high strength steel are described below:

Tensile strength	Major applicable parts
370 - 590 MPa	<ul style="list-style-type: none"> <li>• Lower front and rear hoodledge</li> <li>• Upper hoodledge</li> <li>• Side dash</li> <li>• Roof bow No. 2 and No.4</li> <li>• 3rd, crossmember (Front floor component part)</li> <li>• Inner sill</li> <li>• Rear side member assembly</li> <li>• Lower dash</li> <li>• 2nd, 4th, 5th, and 7th crossmember</li> <li>• Front side member outrigger</li> <li>• 2nd crossmember extension</li> <li>• Seatbelt anchor reinforcement</li> <li>• Center pillar reinforcement</li> <li>• Front seat inner and outer mounting bracket</li> <li>• Side member outrigger</li> <li>• Rear floor front extension</li> <li>• Other reinforcements</li> </ul>
780 - 1350 MPa	<ul style="list-style-type: none"> <li>• Front side member assembly</li> <li>• Front side member closing plate assembly</li> <li>• Front side member extension</li> <li>• Front side member extension front</li> <li>• Outer roof rail reinforcement (Side body assembly component part)</li> <li>• Front suspension inner and outer mounting bracket</li> <li>• Inner sill</li> <li>• Front pillar upper reinforcement</li> <li>• Center pillar outer reinforcement</li> <li>• Front side member stiffener</li> </ul>

Read the following precautions when repairing HSS:

1. Additional points to consider:

- The repair of reinforcements (such as side members) by heating is not recommended since it may weaken the component. When heating is unavoidable, do not heat HSS parts above 550°C (1,022°F).

Verify heating temperature with a thermometer.

(Crayon-type and other similar type thermometers are appropriate.)

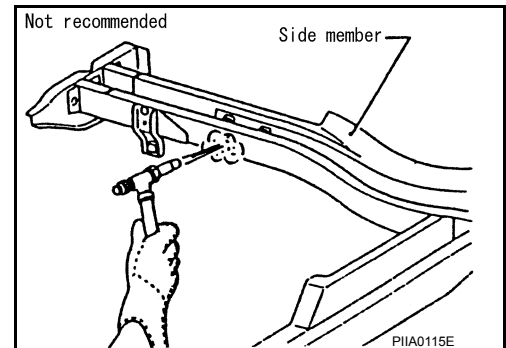

# REPAIRING HIGH STRENGTH STEEL

## < PRECAUTION >

- When straightening body panels, use caution in pulling any HSS panel. Because HSS is very strong, pulling may cause deformation in adjacent portions of the body. In this case, increase the number of measuring points and carefully pull the HSS panel.

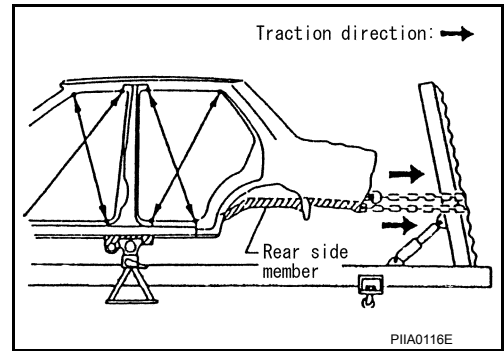

- When cutting HSS panels, avoid gas (torch) cutting if possible. Instead, use a saw to avoid weakening surrounding areas due to heat. If gas (torch) cutting is unavoidable, allow a minimum margin of 50 mm (1.97 in).

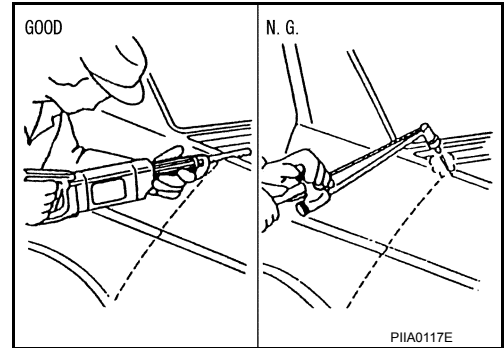

- When welding HSS panels, use spot welding whenever possible in order to minimize weakening surrounding areas due to heat. If spot welding is impossible, use MIG. welding. Do not use gas (torch) for welding because it is inferior in welding strength.

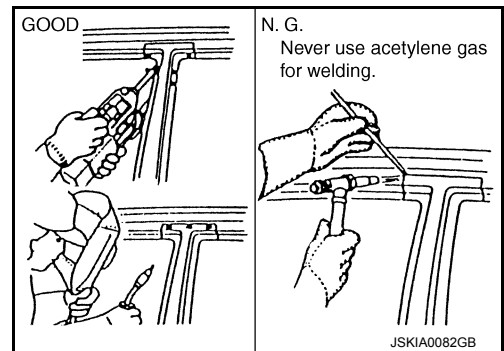

- The spot weld on HSS panels is harder than that of an ordinary steel panel. Therefore, when cutting spot welds on a HSS panel, use a low speed high torque drill (1,000 to 1,200 rpm) to increase drill bit durability and facilitate the operation.

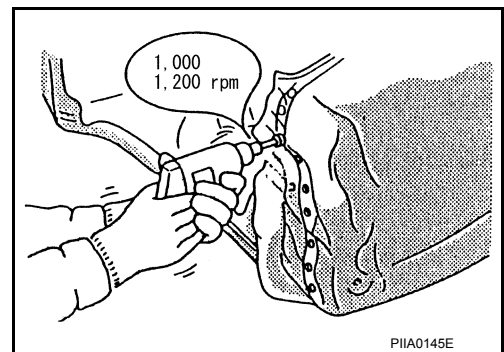

A  
B  
C  
D  
E  
F  
G  
H  
I  
J  
BRM  
L  
M  
N  
O  
P

# REPAIRING HIGH STRENGTH STEEL

## < PRECAUTION >

### 2. Precautions in spot welding HSS

This work should be performed under standard working conditions. Always note the following when spot welding HSS:

- The electrode tip diameter must be sized properly according to the metal thickness.

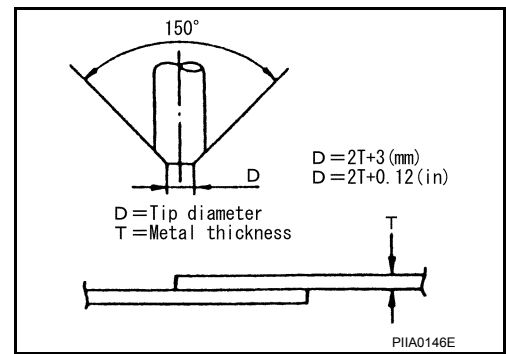

- The panel surfaces must fit flush to each other, leaving no gaps.

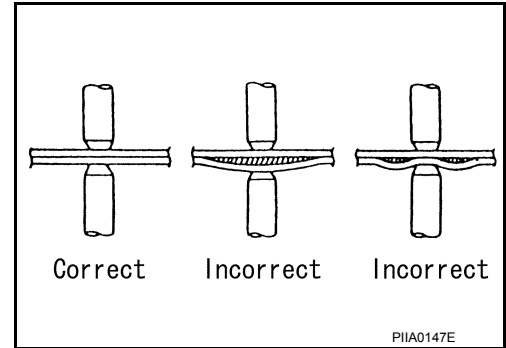

- Follow the specifications for the proper welding pitch.

Unit: mm (in)

Thickness (T)	Minimum pitch (L)
0.6 (0.024)	10 (0.39) or over
0.8 (0.031)	12 (0.47) or over
1.0 (0.039)	18 (0.71) or over
1.2 (0.047)	20 (0.79) or over
1.6 (0.063)	27 (1.06) or over
1.8 (0.071)	31 (1.22) or over

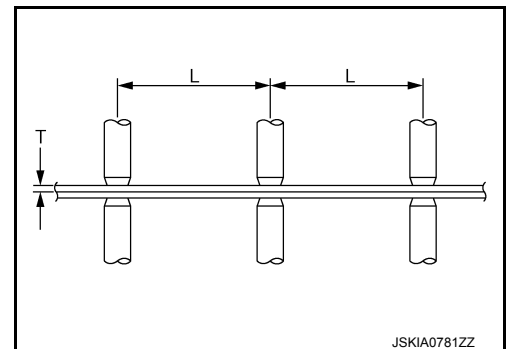

## Handling of Ultra High Strength Steel Plate Parts

INFOID:0000000012852548

### PROHIBITION OF CUT AND CONNECTION

Do not cut and join the lower lock pillar reinforcement (center pillar reinforcement inside frame parts) because its material is high strength steel plate (ultra high strength steel plate).

The center pillar reinforcement must be replaced if this part is damaged.

# REPAIRING MATERIAL

< PREPARATION >

## PREPARATION

### REPAIRING MATERIAL

#### Foam Repair

INFOID:0000000012852549

During factory body assembly, foam insulators are installed in certain body panels and locations around the vehicle. Use the following procedure(s) to replace any factory-installed foam insulators.

#### URETHANE FOAM APPLICATIONS

Use commercially available urethane foam for sealant (foam material) repair of material used on vehicle.

<Urethane foam for foaming agent>

**3M™ Automix™ Flexible Foam 08463 or equivalent**

Read instructions on product for fill procedures.

Example of foaming agent filling operation procedure:

1. Fill procedures after installation of service part.
  - a. Eliminate foam material remaining on vehicle side.
  - b. Clean area after eliminating form insulator and foam material.
  - c. Install service part.
  - d. Insert nozzle into hole near fill area and fill foam material or fill enough to close gap with the service part.

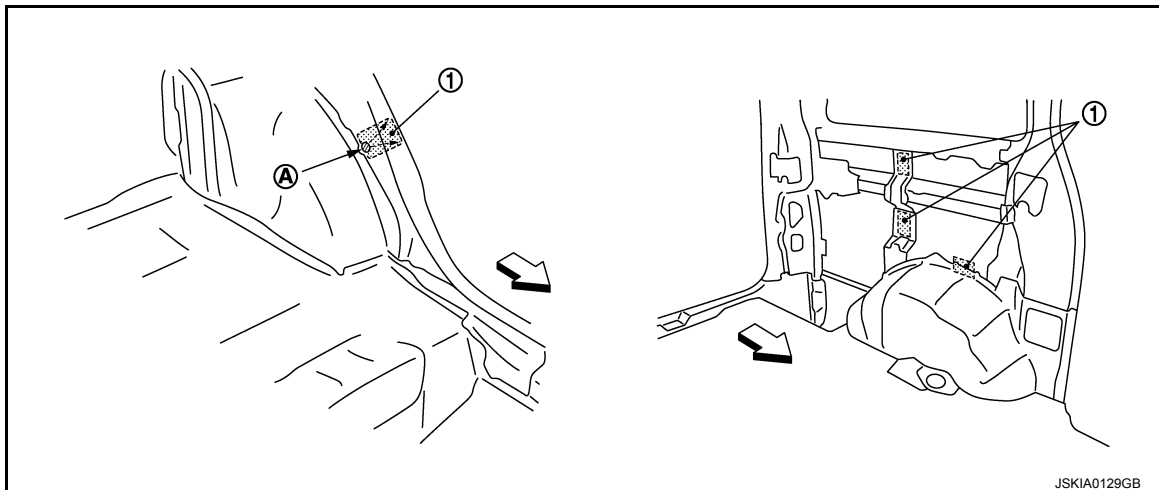

- 1. Urethane foam
- A. Nozzle insert hole
- ↔ Front

2. Fill procedures before installation of service part:
  - a. Eliminate foam material remaining on vehicle side.
  - b. Clean area after eliminating foam insulator and foam material.
  - c. Fill with enough foam material on the wheelhouse outer side to close the gap with the service part while avoiding the flange area.

A  
B  
C  
D  
E  
F  
G  
H  
I  
J  
L  
M  
N  
O  
P

BRM

# REPAIRING MATERIAL

## < PREPARATION >

- 1. Urethane foam
- A. Fill while avoiding flange area
- ⇐ Front

d. Install service part.

**NOTE:**

Refer to the label on the urethane foam container for information on working times.

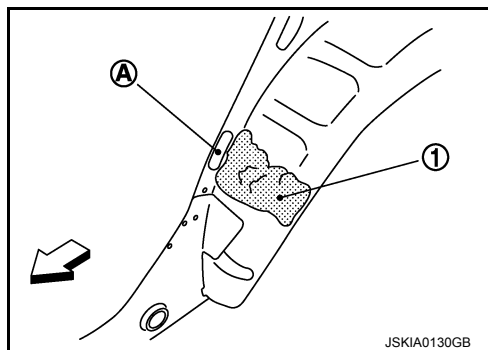



# BODY COMPONENT PARTS

< PREPARATION >

## BODY COMPONENT PARTS

### Underbody Component Parts

INFOID:000000012852550

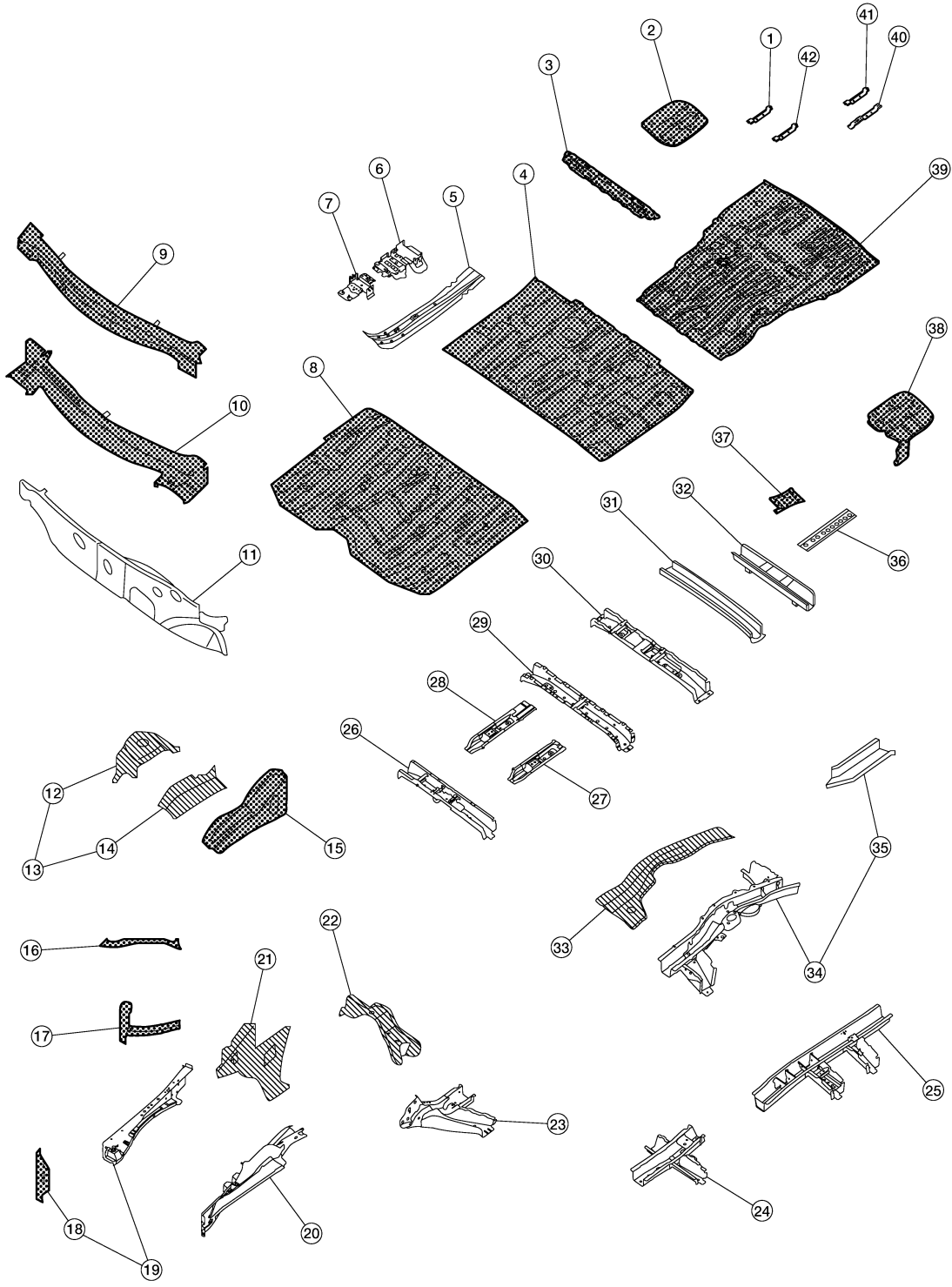



 : Both sided anti-corrosive pre-coated steel portions

AWKIA3980ZZ

# BODY COMPONENT PARTS

## < PREPARATION >

 : High strength steel (HSS) portions

 : Both sided anti-corrosive steel and HSS portions

Item	Part name	Material
1.	Front woofer bracket (LH)	—
2.	Rear floor side assembly (RH)	SP781B
3.	Lower seatback support assembly	SP123B
4.	Rear floor front	—
5.	Front side member stiffener (LH/RH)	SP151-1350Hv
6.	Trim mounting bracket assembly	SP121B
7.	Instrument stay bracket assembly	—
8.	Front floor front	SP781B
9.	Cowl assembly	—
10.	Upper Dash Assembly	SP781B
11.	Lower Dash Assembly	—
12.	Hoodledge lower assembly (RH)	—
13.	Hoodledge assembly (LH)	—
14.	Upper hoodledge (LH)	SP781-390B
15.	Hoodledge extension (LH)	SP781B
16.	Upper radiator core support (LH)	SP781B
17.	Radiator core support (LH)	SP782B
18.	Front side member connector (LH)	SP781B
19.	Front side member assembly (LH)	—
20.	Front side member closing plate assembly (LH)	—
21.	Dash side assembly (LH)	—
22.	Front suspension member lower mounting assembly	SP781-440
23.	Front side member assembly (LH)	—
24.	Front side member extension assembly (LH)	—
25.	Front side member rear extension assembly (LH)	—
26.	3rd crossmember assembly	—
27.	Rear inner belt anchor reinforcement assembly (LH)	—
28.	Rear inner belt anchor reinforcement assembly (RH)	—
29.	4th crossmember assembly	—
30.	5th crossmember assembly	—
31.	6th crossmember assembly	—
32.	7th crossmember assembly	—
33.	Rear floor front extension assembly (LH)	—
34.	Rear side member assembly (LH)	—
35.	Rear side member extension assembly (LH)	—
36.	Rear member center assembly	SP781B
37.	Spare tire mounting bracket	SP781B
38.	Rear floor side assembly (LH)	SP781B
39.	Rear floor rear	SP781B
40.	Rear woofer bracket (LH)	—
41.	Rear woofer bracket (RH)	—
42.	Front woofer bracket (RH)	—

# BODY COMPONENT PARTS

< PREPARATION >

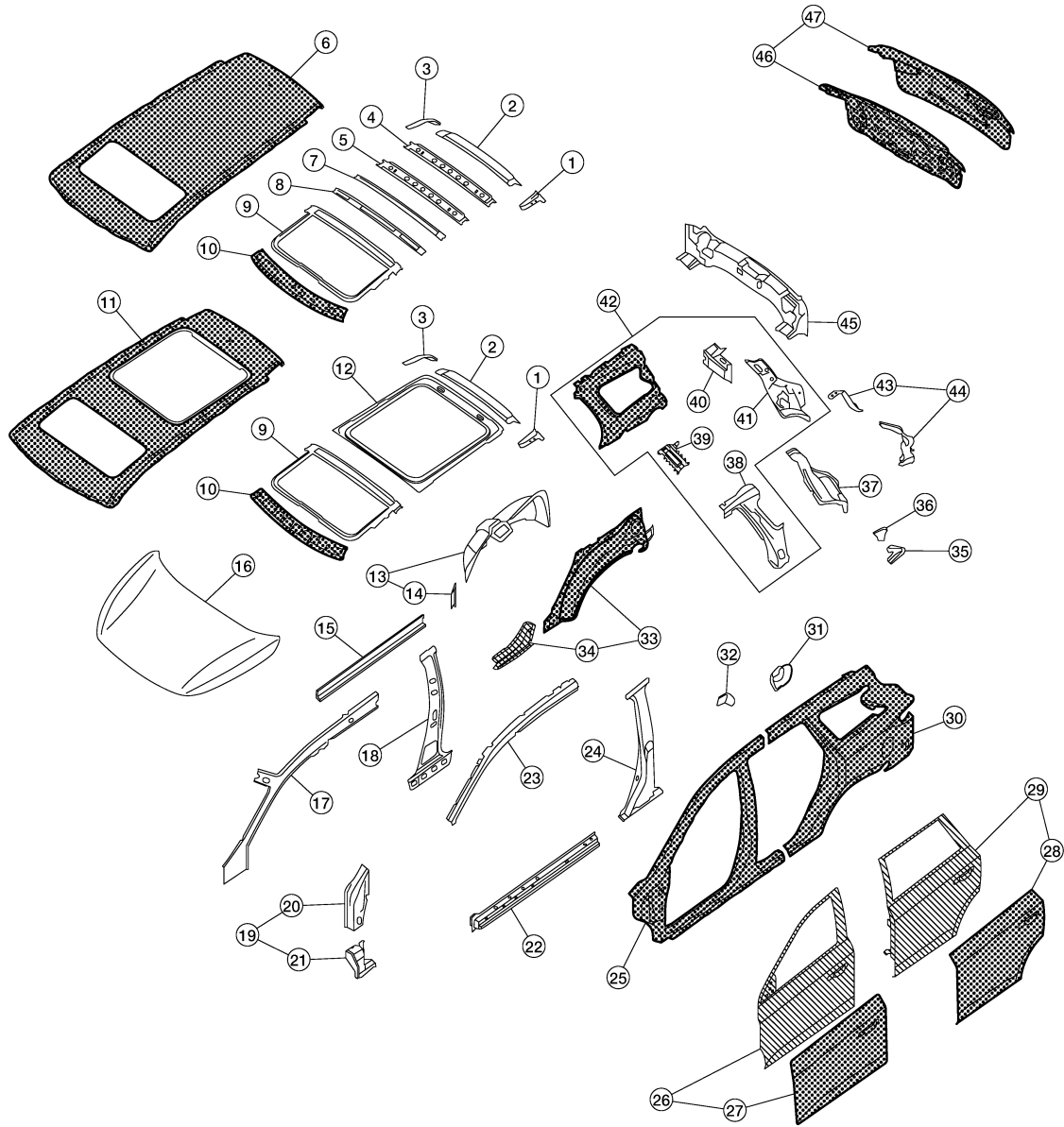

## Body Component Parts

INFOID:000000012852551



A  
B  
C  
D  
E  
F  
G  
H  
I  
J  
L  
M  
N  
O  
P

BRM

-  :Both sided anti-corrosive pre-coated steel portions
-  :High strength steel (HSS) portions
-  :Both sided anti-corrosive steel and HSS portions

AWKIA3981ZZ

# BODY COMPONENT PARTS

< PREPARATION >

Item	Part name	Material
1.	Roof corner reinforcement (LH)	SP781B
2.	Rear roof rail assembly	SP781AM
3.	Roof corner reinforcement (RH)	SP781B
4.	6th roof bow, standard roof	SP129B
5.	5th roof bow, standard roof	SP129B
6.	Standard roof	SP121AQ
7.	4th roof bow, standard roof	SP129B
8.	3rd roof bow, standard roof	SP123B
9.	Roof reinforcement assembly, standard roof	SP121BQ
10.	Front roof rail assembly	—
11.	Panoramic roof	SP121AQ
12.	Rear roof reinforcement assembly	SP121B
13.	Rear wheel inner assembly (LH/RH)	—
14.	Rear wheel inner front extension	SP781B
15.	Inner sill (LH/RH)	—
16.	Hood assembly	—
17.	Inner roof side rail complete (LH/RH)	—
18.	Center pillar inner (LH/RH)	—
19.	Front hinge pillar reinforcement assembly (LH/RH)	—
20.	Front pillar upper hinge brace (LH/RH)	SP153-590
21.	Front pillar lower hinge brace (LH/RH)	SP152-440
22.	Outer sill reinforcement assembly (LH/RH)	—
23.	Roof side outer reinforcement assembly (LH/RH)	—
24.	Center pillar reinforcement (LH/RH)	—
25.	Front body side outer (LH/RH)	SP781AM
26.	Front door assembly (LH/RH)	—
27.	Front door outer (LH/RH)	SP785-340
28.	Rear door outer (LH/RH)	SP785-340
29.	Rear door assembly (LH/RH)	—
30.	Rear body side outer	SP781AM
31.	Fuel filler base	SP123
32.	Striker retainer (LH/RH)	SP121B
33.	Rear wheel outer assembly	—
34.	Rear outer sill reinforcement assembly (LH/RH)	—
35.	Rear fender cover lower (LH/RH)	SP781
36.	Rear fender cover upper (LH/RH)	SP781
37.	Outer back pillar assembly (LH/RH)	—
38.	Rear pillar inner reinforcement assembly (LH/RH)	—
39.	Rear pillar seat belt anchor assembly (LH/RH)	SP131-370
40.	Rear fender brace (LH/RH)	SP123BQ
41.	Inner back pillar assembly (LH/RH)	—
42.	Inner rear pillar complete assembly (LH/RH)	—
43.	Main back pillar assembly (LH/RH)	SP121BQ
44.	Rear combination lamp base assembly (LH/RH)	—
45.	Rear panel assembly	—
46.	Back door assembly	—
47.	Back door outer	SP781AQ

# CORROSION PROTECTION

< REMOVAL AND INSTALLATION >

## REMOVAL AND INSTALLATION

### CORROSION PROTECTION

#### Description

INFOID:0000000012852552

To provide improved corrosion prevention, the following anti-corrosive measures have been implemented in INFINITI production plants. When repairing or replacing body panels, it is necessary to use the same anti-corrosive measures.

#### Anti-Corrosive Precoated Steel (Galvannealed Steel)

To improve repairability and corrosion resistance, a new type of anti-corrosive precoated steel sheet has been adopted, replacing conventional zinc-coated steel sheet.

Galvannealed steel is electroplated and heated to form zinc-iron alloy, which provides excellent and long term corrosion resistance with cationic electrodeposition primer.

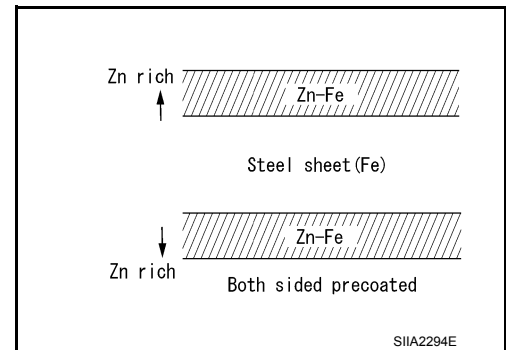

INFINITI Genuine Service Parts are fabricated from galvannealed steel. Therefore, it is recommended that GENUINE INFINITI PARTS or equivalent be used for panel replacement to maintain the anti-corrosive performance built into the vehicle at the factory.

#### Phosphate Coating Treatment and Cationic Electrodeposition Primer

A phosphate coating treatment and a cationic electrodeposition primer, which provide excellent corrosion protection, are employed on all body components.

#### **CAUTION:**

**Confine paint removal during welding operations to an absolute minimum.**

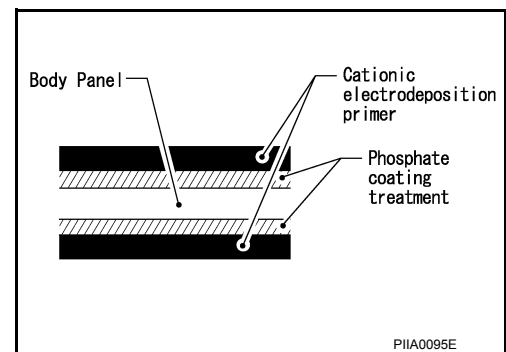

INFINITI Genuine Service Parts are also treated in the same manner. Therefore, it is recommended that GENUINE INFINITI PARTS or equivalent be used for panel replacement to maintain anti-corrosive performance built into the vehicle at the factory.

#### Anti-Corrosive Wax

INFOID:0000000012852553

To improve corrosion resistance, anti-corrosive wax is applied inside the body sill and inside other closed sections. Accordingly, when replacing these parts, be sure to apply anti-corrosive wax to the appropriate areas of the new parts. Select an excellent anti-corrosive wax which will penetrate after application and has a long shelf life.

# CORROSION PROTECTION

## < REMOVAL AND INSTALLATION >

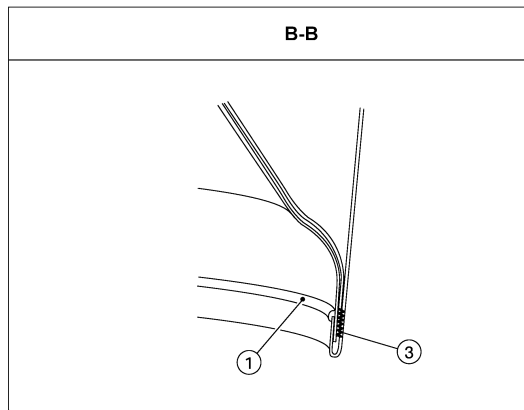
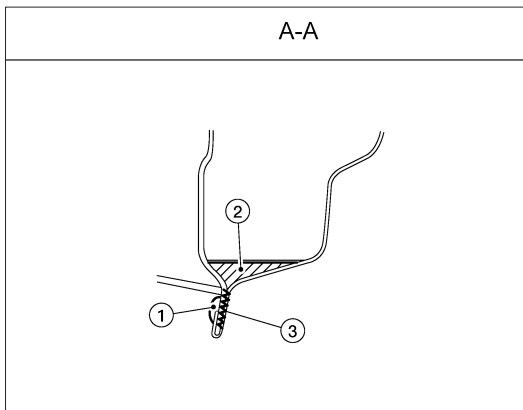
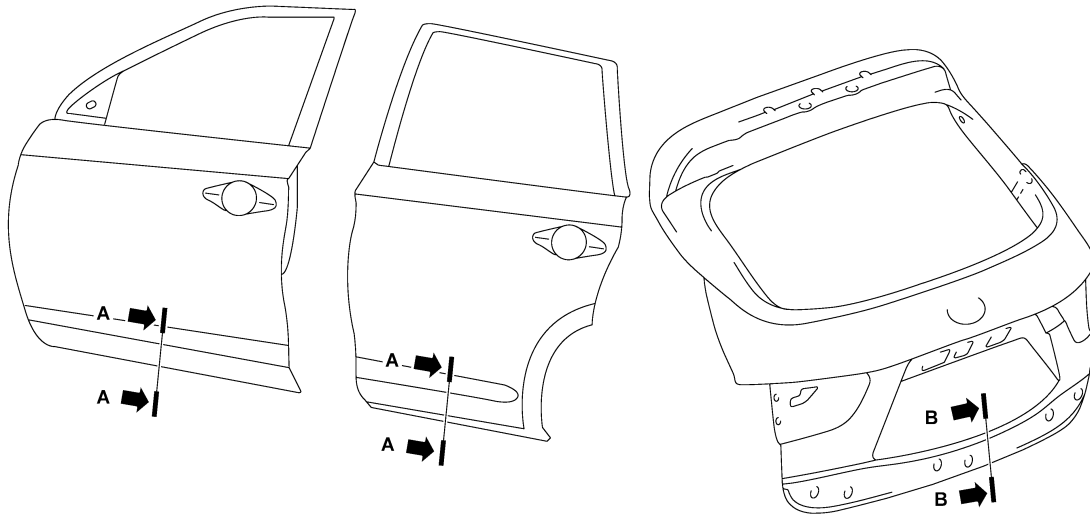

AWKIA3833ZZ

1. Body caulk

2. Anti-corrosive wax

3. Panel adhesive

## Undercoating

INFOID:000000012852554

The underside of the floor and wheelhouse are undercoated to prevent rust, vibration, noise and stone chipping. Therefore, when such a panel is replaced or repaired, apply undercoating to that part. Use an undercoating which is rust preventive, soundproof, vibration-proof, shock-resistant, adhesive, and durable.

### Precautions in Undercoating

1. Do not apply undercoating unless specified. Avoid areas such as the areas above the muffler and three-way catalyst which are subjected to heat.
2. Do not undercoat the exhaust pipe or other parts which become hot.

# CORROSION PROTECTION

## < REMOVAL AND INSTALLATION >

3. Do not undercoat rotating parts.
4. Apply bitumen wax after applying undercoating.
5. After putting seal on the vehicle, put undercoating on it.

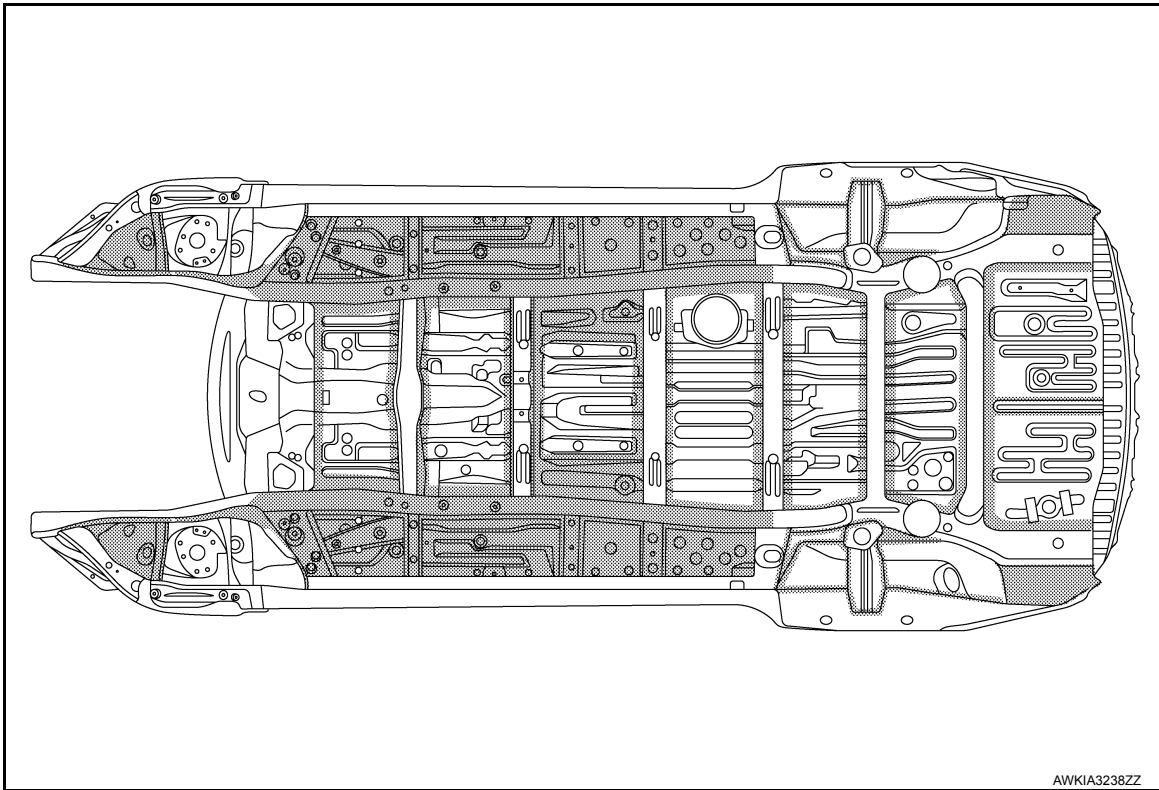

Undercoated areas are shaded.

A  
B  
C  
D  
E  
F  
G  
H  
I  
J  
L  
M  
N  
O  
P

BRM

# BODY SEALING

< REMOVAL AND INSTALLATION >

## BODY SEALING

### Description

INFOID:000000012852555

The following figure shows the areas which are sealed at the factory. Sealant which has been applied to these areas should be smooth and free from cuts or gaps. Care should be taken not to apply an excess amount of sealant and not to allow other unaffected parts to come into contact with the sealant.

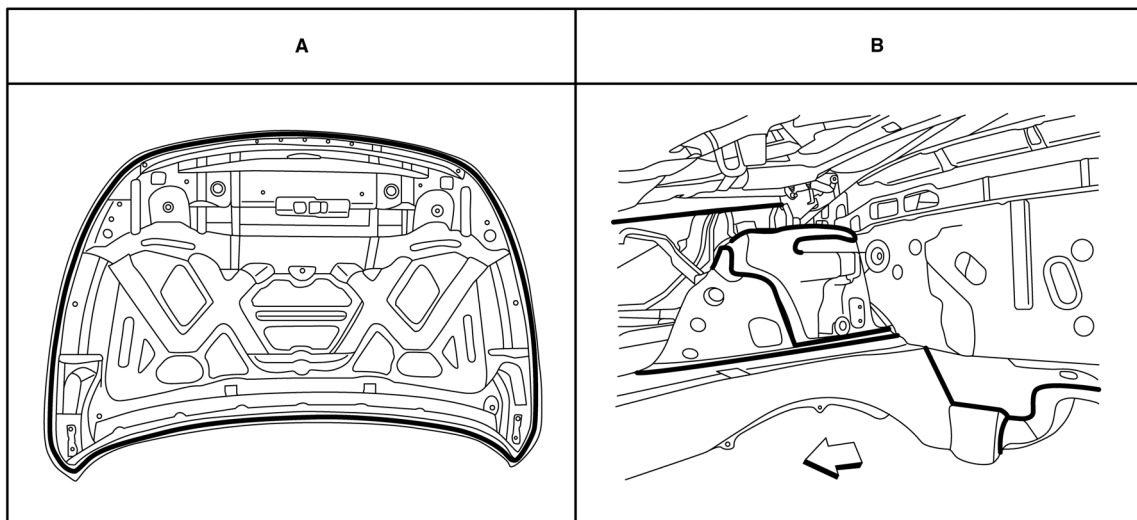
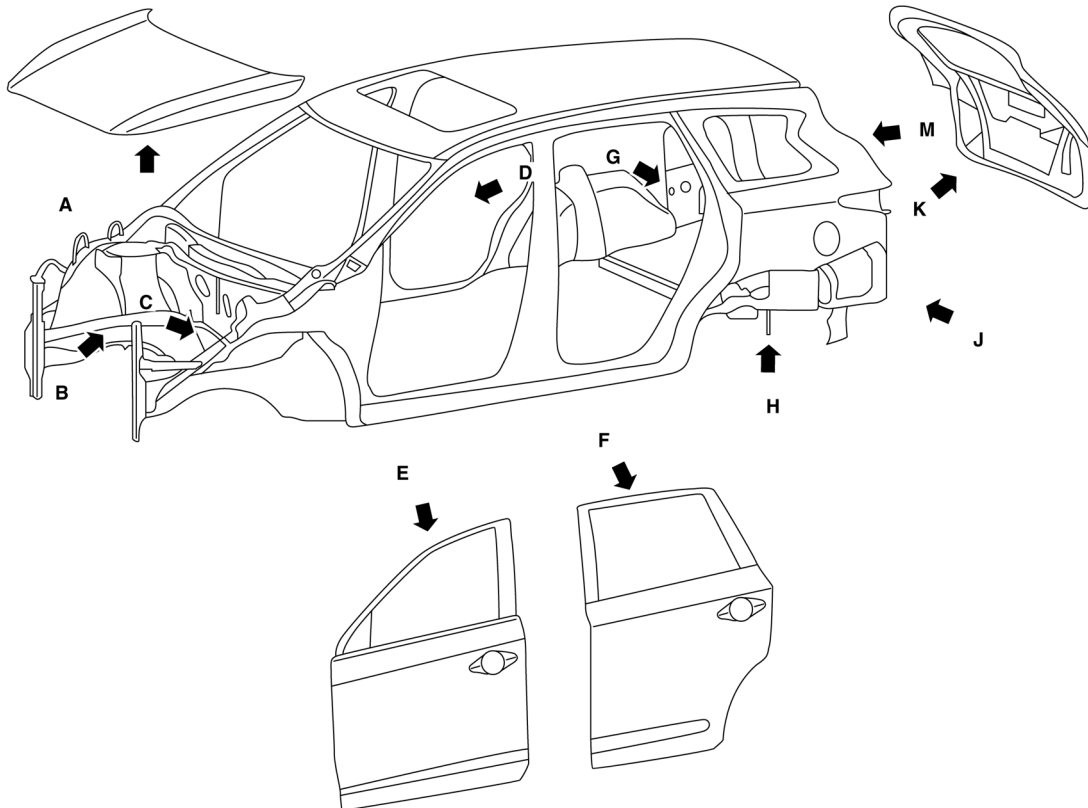

ALKIA2378ZZ



# BODY SEALING

## < REMOVAL AND INSTALLATION >

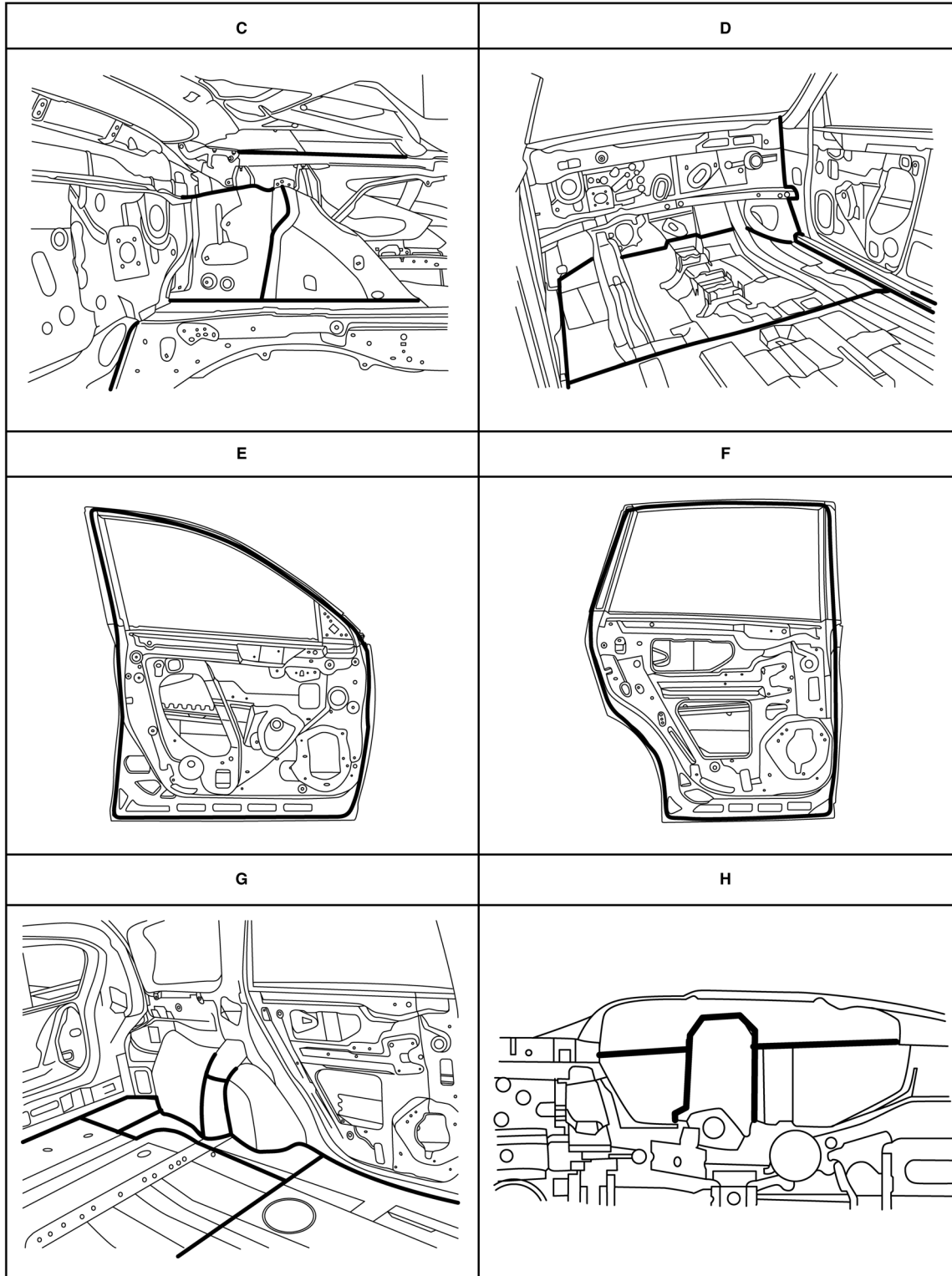

ALKIA2379ZZ

A  
B  
C  
D  
E  
F  
G  
H  
I  
J  
K  
L  
M  
N  
O  
P

BRM

# BODY SEALING

< REMOVAL AND INSTALLATION >

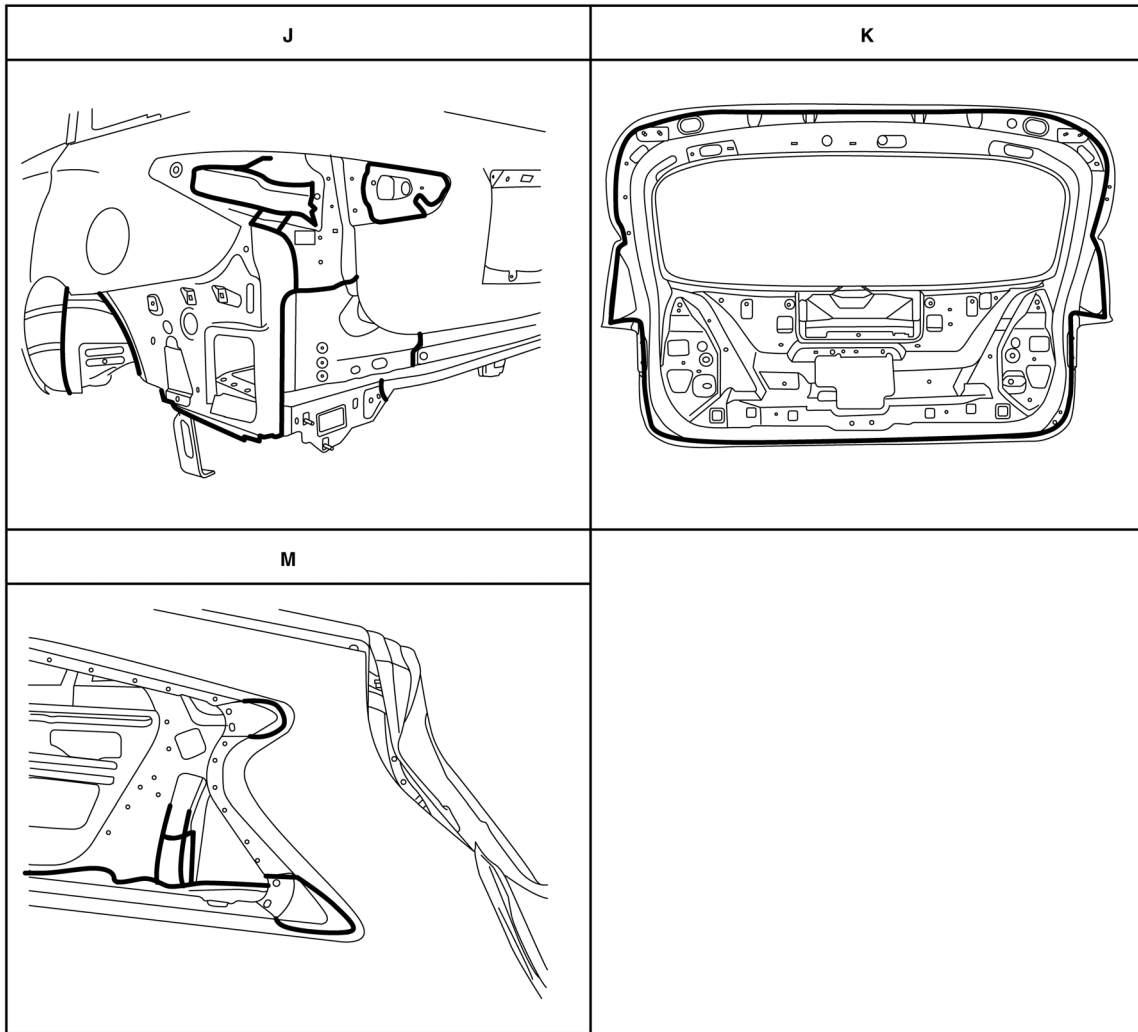

ALKIA2380ZZ

# BODY CONSTRUCTION

< REMOVAL AND INSTALLATION >

## BODY CONSTRUCTION

### Body Construction

INFOID:000000012852556

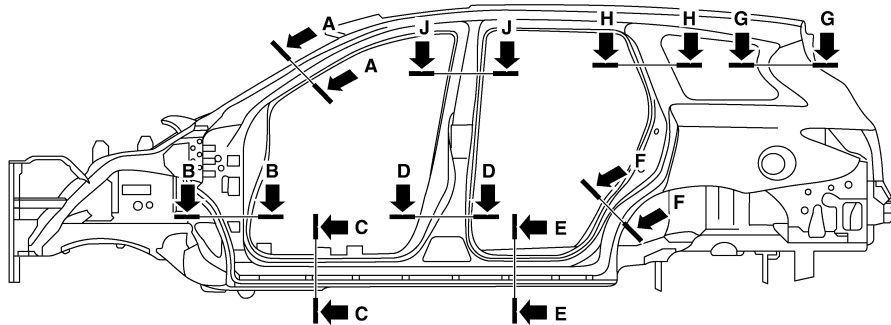

A-A	B-B	C-C
D-D	E-E	F-F
G-G	H-H	J-J

- |                    |   |                                     |
|--------------------|---|-------------------------------------|
| 1. Body side outer | 2. Front pillar inner upper               | 3. Upper front pillar reinforcement |
| 4. Dash side inner | 5. Front hinge pillar lower reinforcement | 6. Outer sill reinforcement         |
| 7. Inner sill      | 8. Center pillar reinforcement            | 9. Inner center pillar              |

A  
B  
C  
D  
E  
F  
G  
H  
I  
J  
L  
M  
N  
O  
P

BRM

## BODY CONSTRUCTION

### < REMOVAL AND INSTALLATION >

---

- |                              |                                 |                                     |
|------------------------------|---------------------------------|-------------------------------------|
| 10. Rear sill assembly       | 11. Rear wheel housing assembly | 12. Back pillar inner reinforcement |
| 13. Roof rail brace assembly | 14. Back pillar inner           | 15. Rear pillar inner reinforcement |

# REPLACEMENT OPERATIONS

< REMOVAL AND INSTALLATION >

## REPLACEMENT OPERATIONS

### Precautions for Body Repair

INFOID:000000013509569

#### **WARNING:**

- The repair information in this section is intended for trained body repair technicians who have attained a high level of skill and experience (e.g. ASE Collision Repair Certification, I-CAR Professional Development Program [PDP] training, etc.) in repairing collision damaged vehicles using appropriate tools and equipment. Performing repairs without the proper training, tools or equipment could damage the vehicle or cause personal injury or death to you or others.
- The information in this Body Repair Manual is a guideline for repairing collision damaged vehicles. However, this information cannot cover all possible ways that a vehicle can be damaged. As such, the body repair technician is responsible for making sure that the repair does not affect the structural integrity or safety of the vehicle. Improper repair of a damaged vehicle may result in a collision, property damage, personal injury or death.
- Infiniti recommends using only new genuine Infiniti replacement body parts. Use of used, salvaged or aftermarket body parts is not recommended by Infiniti. Non-genuine Infiniti components may affect the vehicle's structural integrity and crash safety performance, which could result in serious personal injury or death in an accident.

### Description

INFOID:000000012852557

Technicians are encouraged to read Body Repair Manual (Fundamentals) in order to ensure that the original functions and quality of the vehicle can be maintained. The Body Repair Manual (Fundamentals) contains additional information, including cautions and warnings, that are not including in this manual. Technicians should refer to both manuals to ensure proper repairs.

Please note that this information is prepared for worldwide usage, and as such, certain procedures might not apply in some regions or countries.









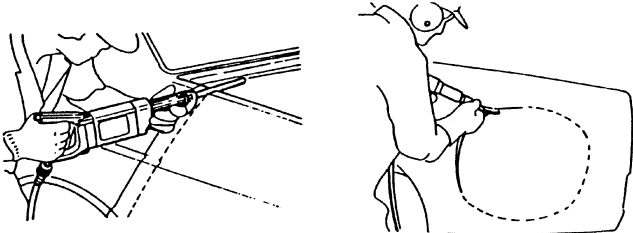
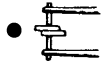

A  
B  
C  
D  
E  
F  
G  
H  
I  
J  
L  
M  
N  
O  
P

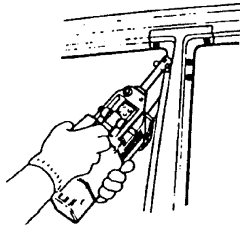
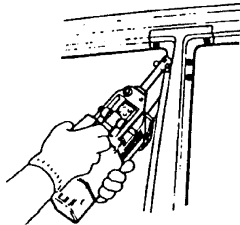
BRM

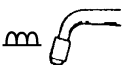
# REPLACEMENT OPERATIONS

## < REMOVAL AND INSTALLATION >

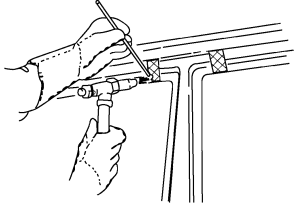
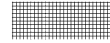
The symbols used in this section for cutting and welding / brazing operations are shown below.

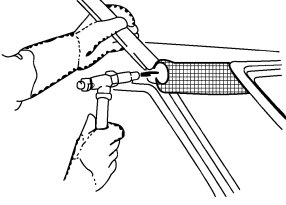
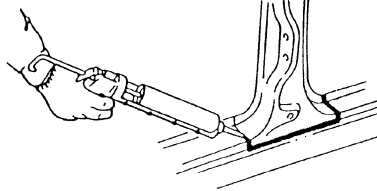
 <p>Saw cut or air chisel cut</p>		
<p>Spot weld</p> <p>●●●● 2-spot welds</p>  <p>●●●● 3-spot welds</p> 	<p>2-spot welds (2-panel overlapping portions)</p>  <p>3-spot welds (3-panel overlapping portions)</p> 	
<p>■ ■ ■ ■ MIG plug weld</p>  <p>~~~~~ MIG seam weld/ Point weld</p> 		
<p>▨ ▨ ▨ ▨ Brazing</p>  		
<p>▨ ▨ ▨ ▨ Soldering</p>  		
<p>————— Sealing</p>		

PIIA0149E

# REPLACEMENT OPERATIONS

## < REMOVAL AND INSTALLATION >

- Front pillar butt joint can be determined anywhere within shaded area as shown in the figure. The best location for the butt joint is at position A due to the construction of the vehicle. Refer to the front pillar section.

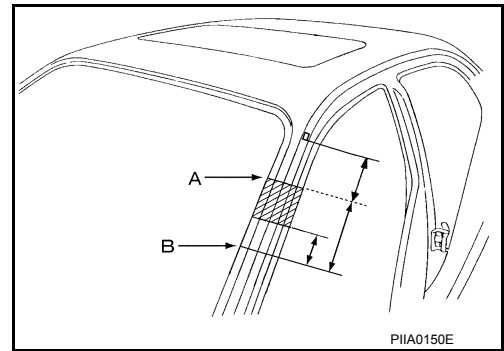

- Determine cutting position and record distance from the locating indent. Use this distance when cutting the service part. Cut outer front pillar over 60 mm (2.4 in) above inner front pillar cut position.

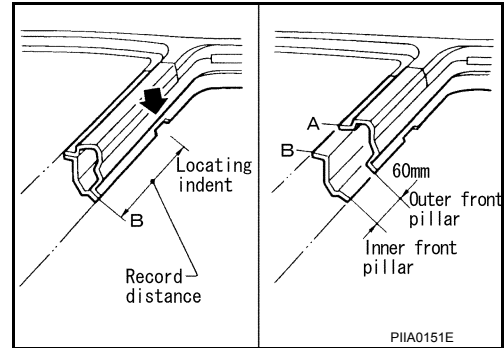

- Prepare a cutting jig to make the outer pillar easier to cut. Also, this will permit the service part to be accurately cut at the joint position.

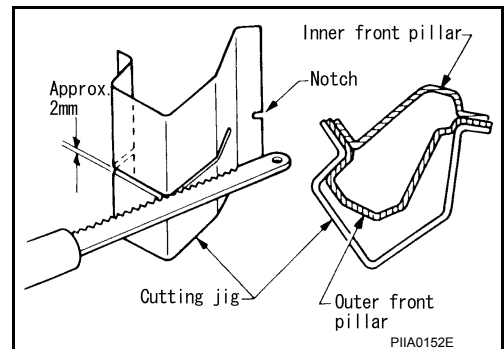

- An example of cutting operation using a cutting jig is as follows:

1. Mark cutting lines.  
A: Cut position of outer pillar
2. Align cutting line with notch on jig. Clamp jig to pillar.
3. Cut outer pillar along groove of jig. (At position A)
4. Remove jig and cut remaining portions.

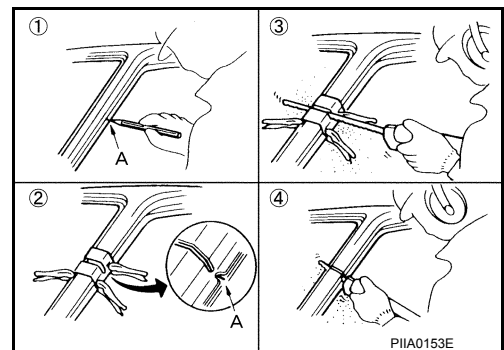

A  
B  
C  
D  
E  
F  
G  
H  
I  
J  
L  
M  
N  
O  
P

BRM

# REPLACEMENT OPERATIONS

< REMOVAL AND INSTALLATION >

## Hoodledge

INFOID:000000012852558

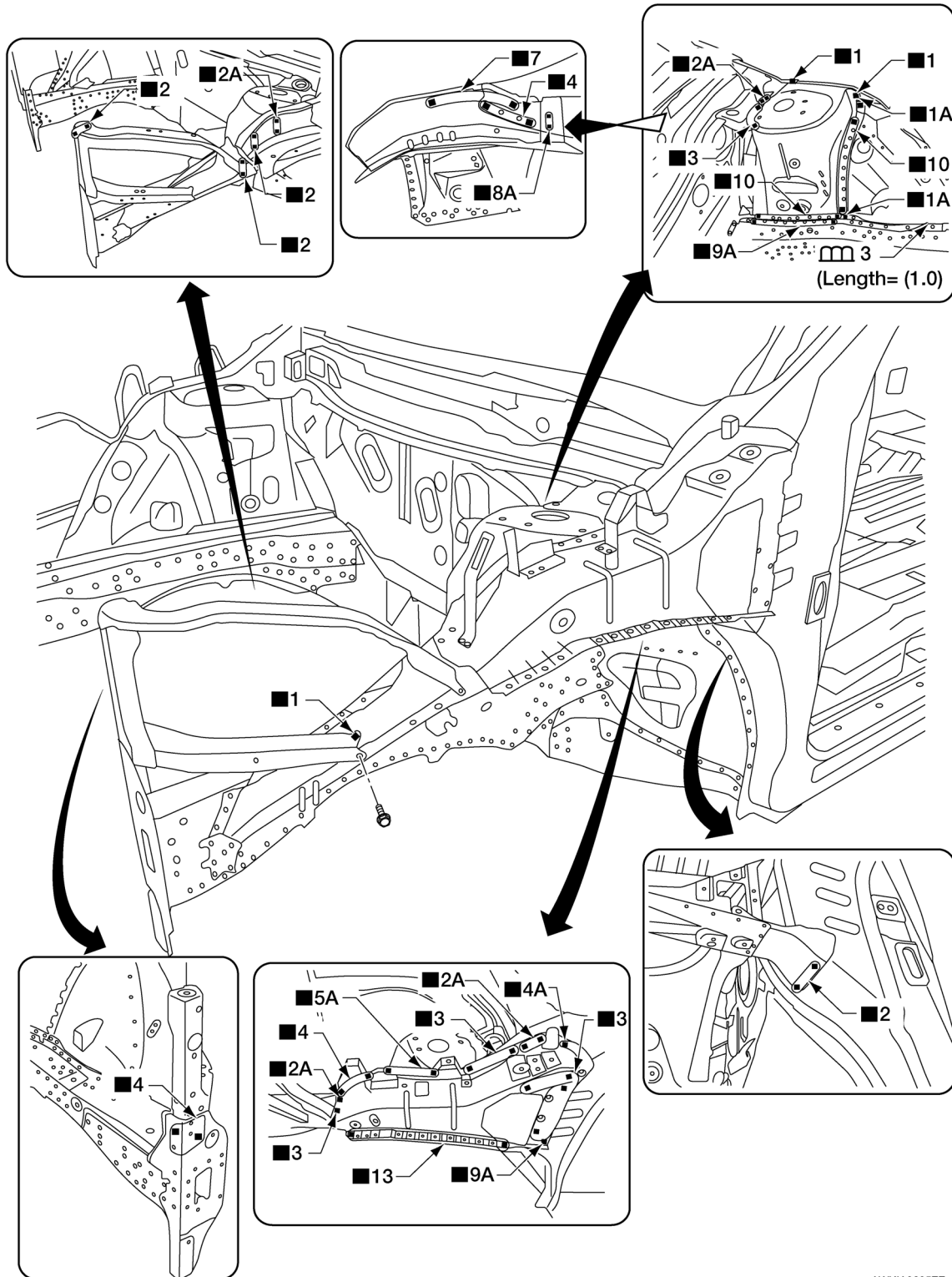

AWKIA3235ZZ

Unit: mm (in)

### Replacement parts

- Front suspension spring support
- Hoodledge reinforcement
- Upper radiator core support

## Front Side Member (Partial Replacement)

INFOID:000000012852559

Work after the hoodledge has been removed.

Revision: April 2016

**BRM-28**

2016 QX60



# REPLACEMENT OPERATIONS

< REMOVAL AND INSTALLATION >

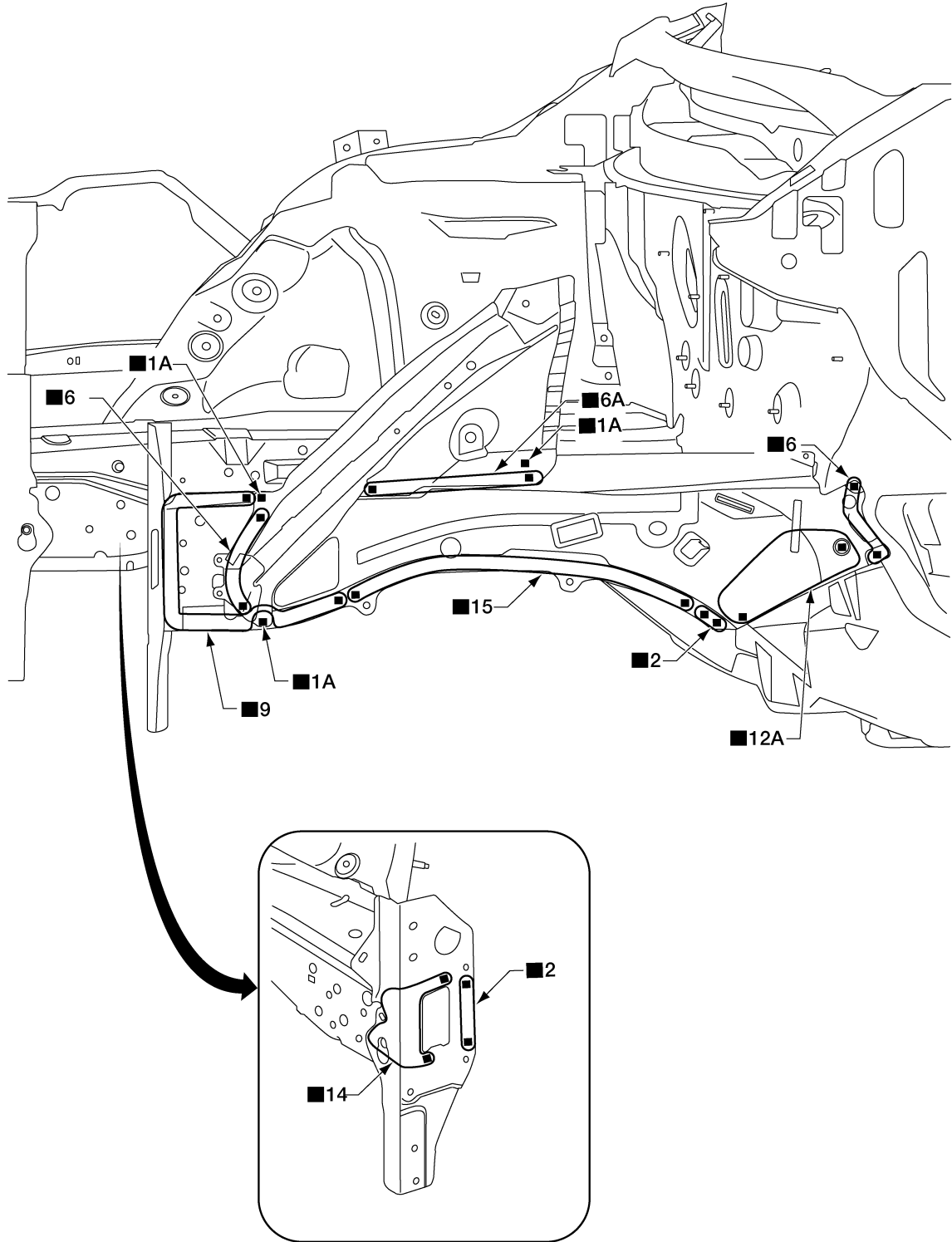

A  
B  
C  
D  
E  
F  
G  
H  
I  
J  
K  
L  
M  
N  
O  
P

BRM

AWKIA3236ZZ

## Replacement parts

- Front side member
- Closing plate assembly
- Radiator core side support

## Front Pillar

INFOID:000000012852560

## OUTER

- Work after the upper hoodedge has been removed.

# REPLACEMENT OPERATIONS

< REMOVAL AND INSTALLATION >

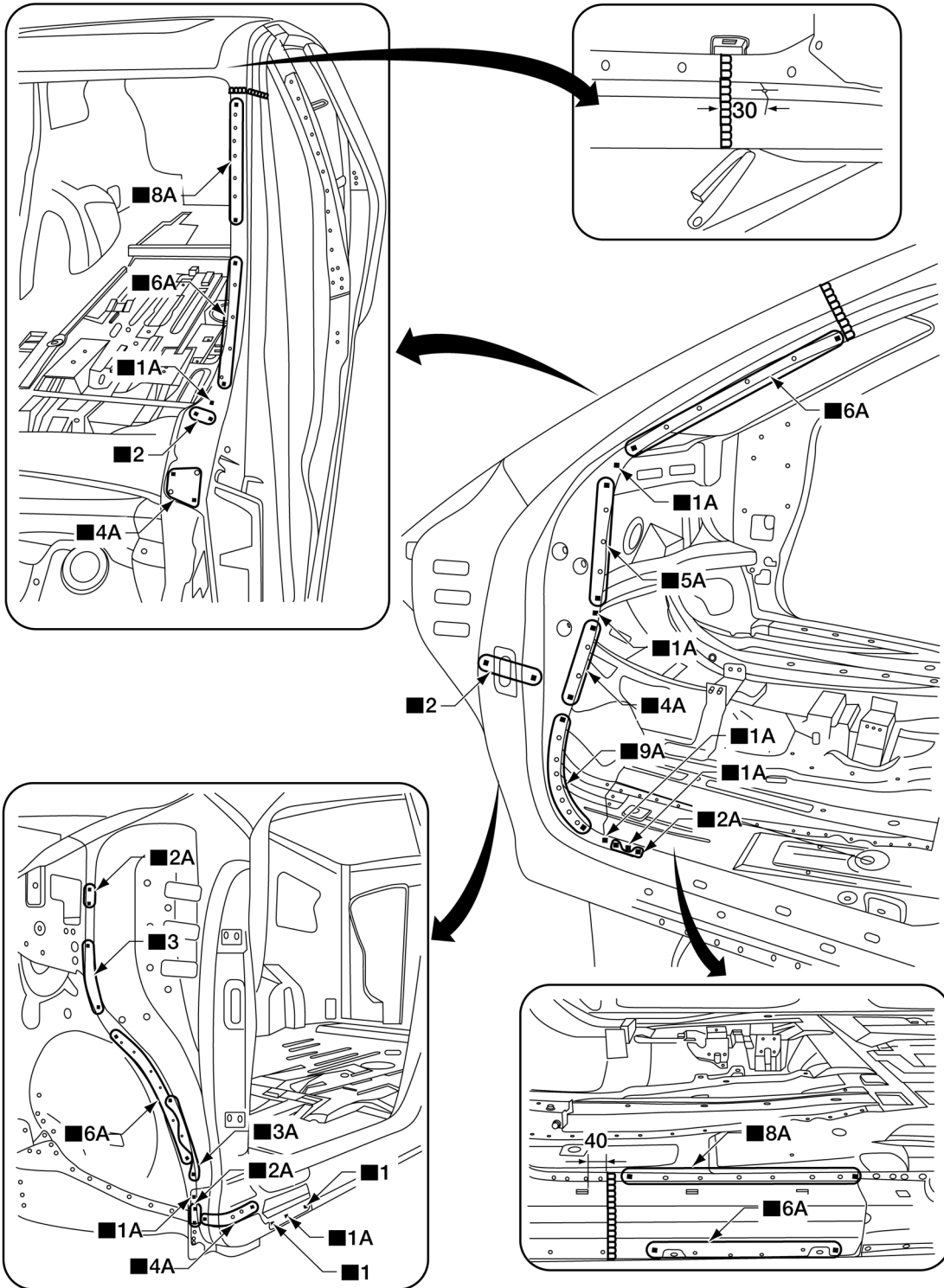

ALKIA2447ZZ

Unit: mm

Replacement parts

- Front pillar section of front body side outer

## HINGE PILLAR BRACE

Upper

- Work after front pillar outer has been removed.

# REPLACEMENT OPERATIONS

< REMOVAL AND INSTALLATION >

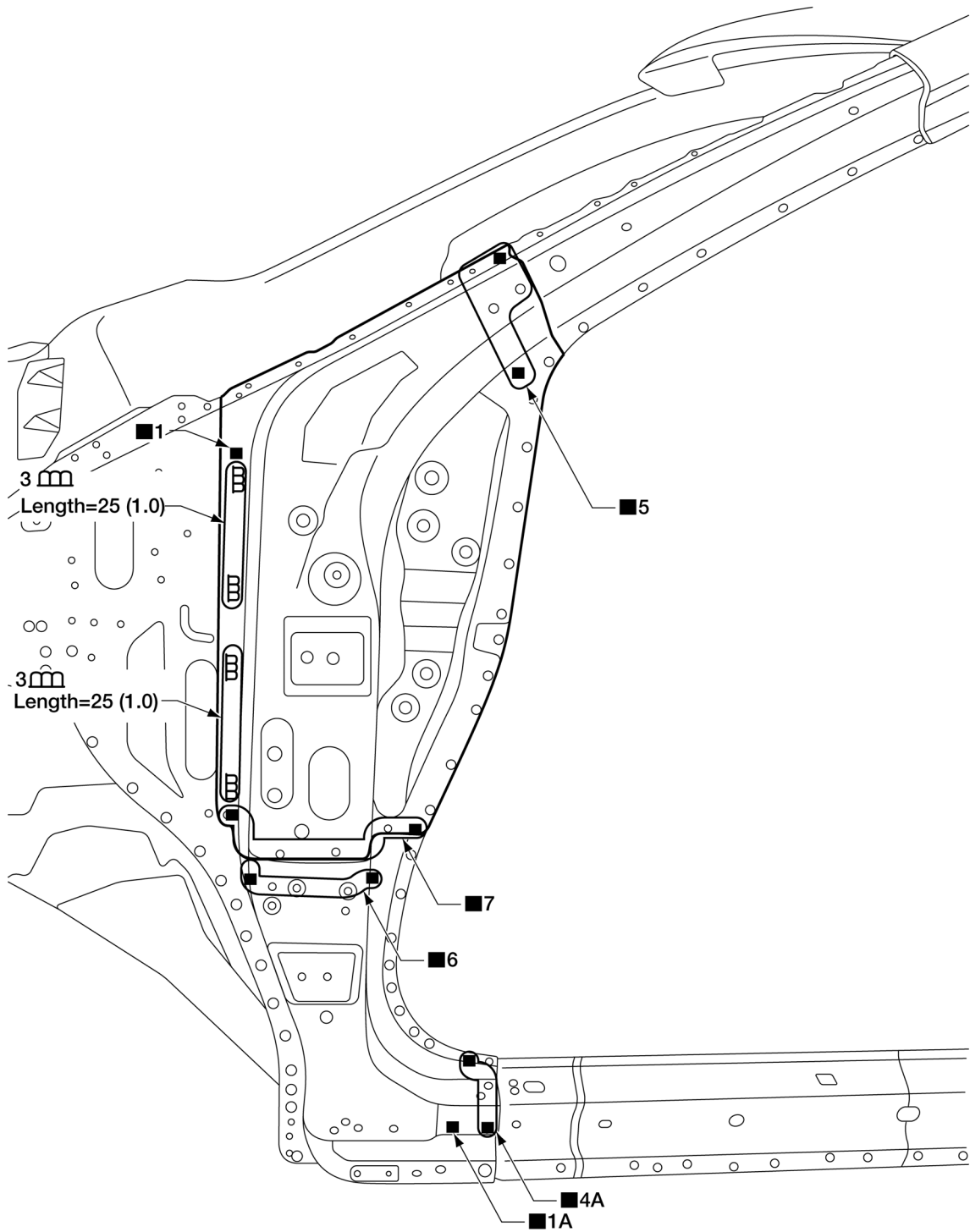

ALKIA2448ZZ

Unit: mm (in)

Replacement parts

- Front pillar upper hinge brace

Lower

- Work after hinge pillar upper has been removed.

# REPLACEMENT OPERATIONS

< REMOVAL AND INSTALLATION >

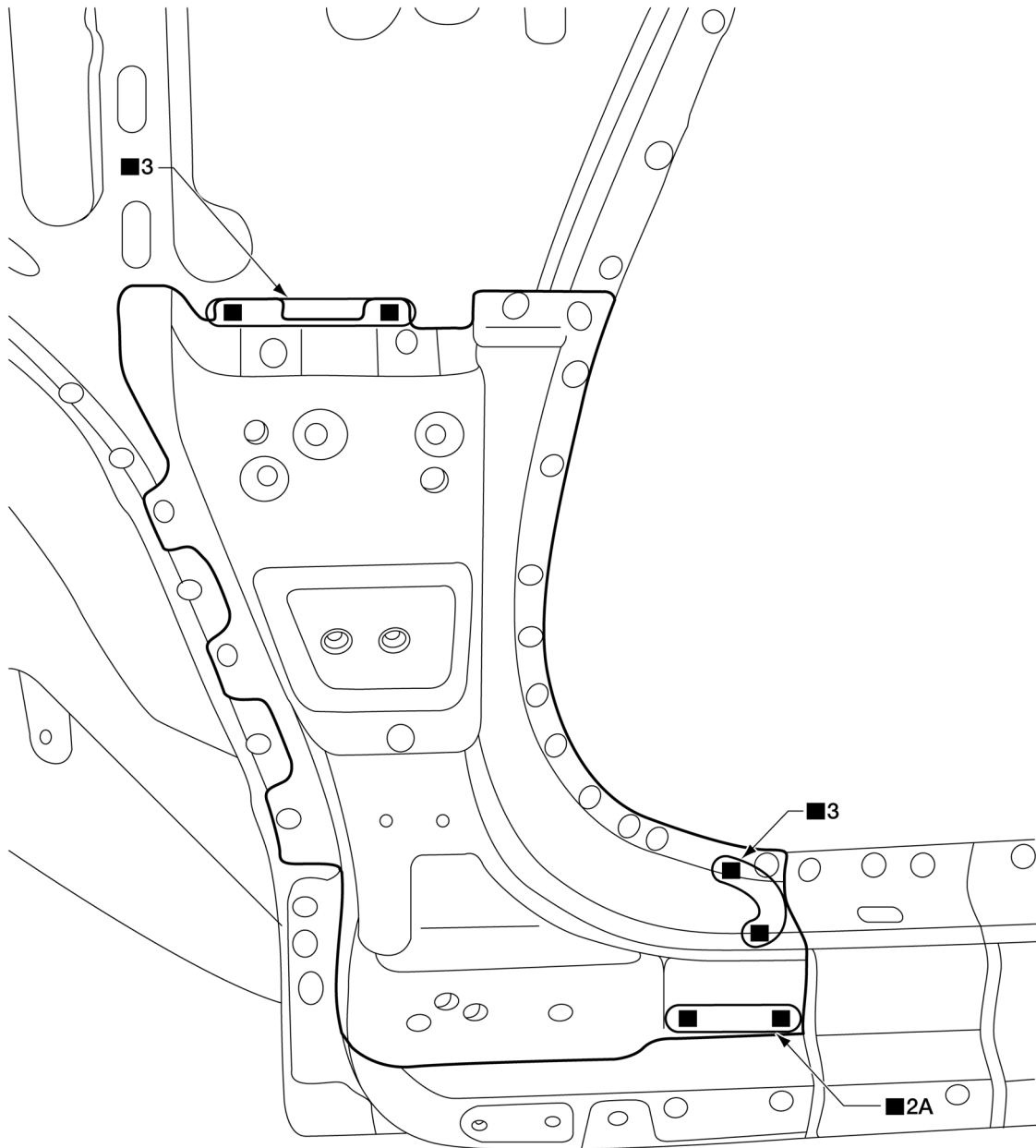

ALKIA2449ZZ

## Replacement parts

- Front pillar lower hinge brace

## Dash Side

INFOID:000000012852561

Work after the front pillar portion of body side inner reinforcement and the front pillar lower hinge brace have been removed.

# REPLACEMENT OPERATIONS

< REMOVAL AND INSTALLATION >

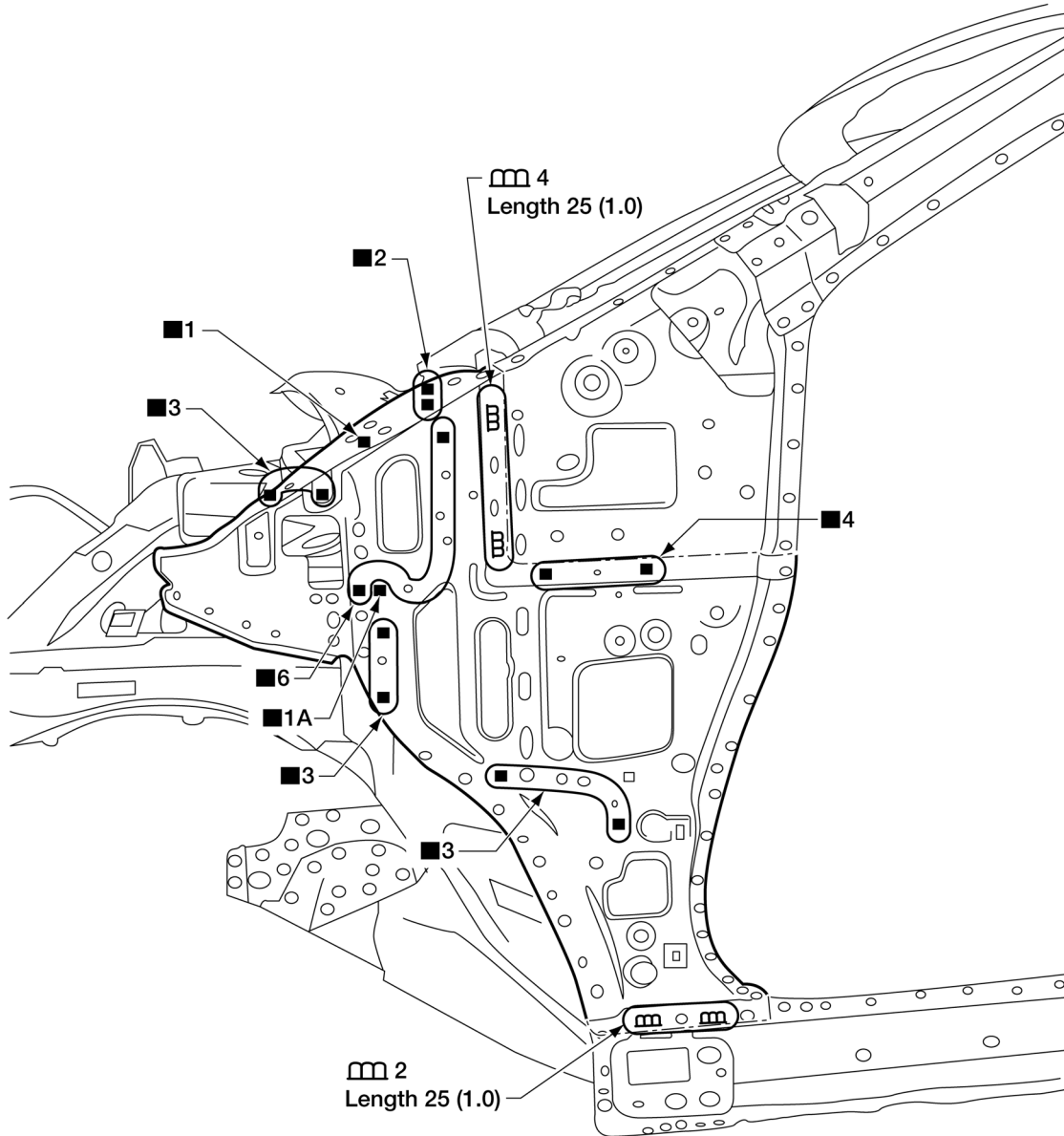

Replacement parts

- Dash side

Center Pillar

OUTER

ALKIA2522ZZ

Unit: mm (in)

INFOID:000000012852562

# REPLACEMENT OPERATIONS

< REMOVAL AND INSTALLATION >

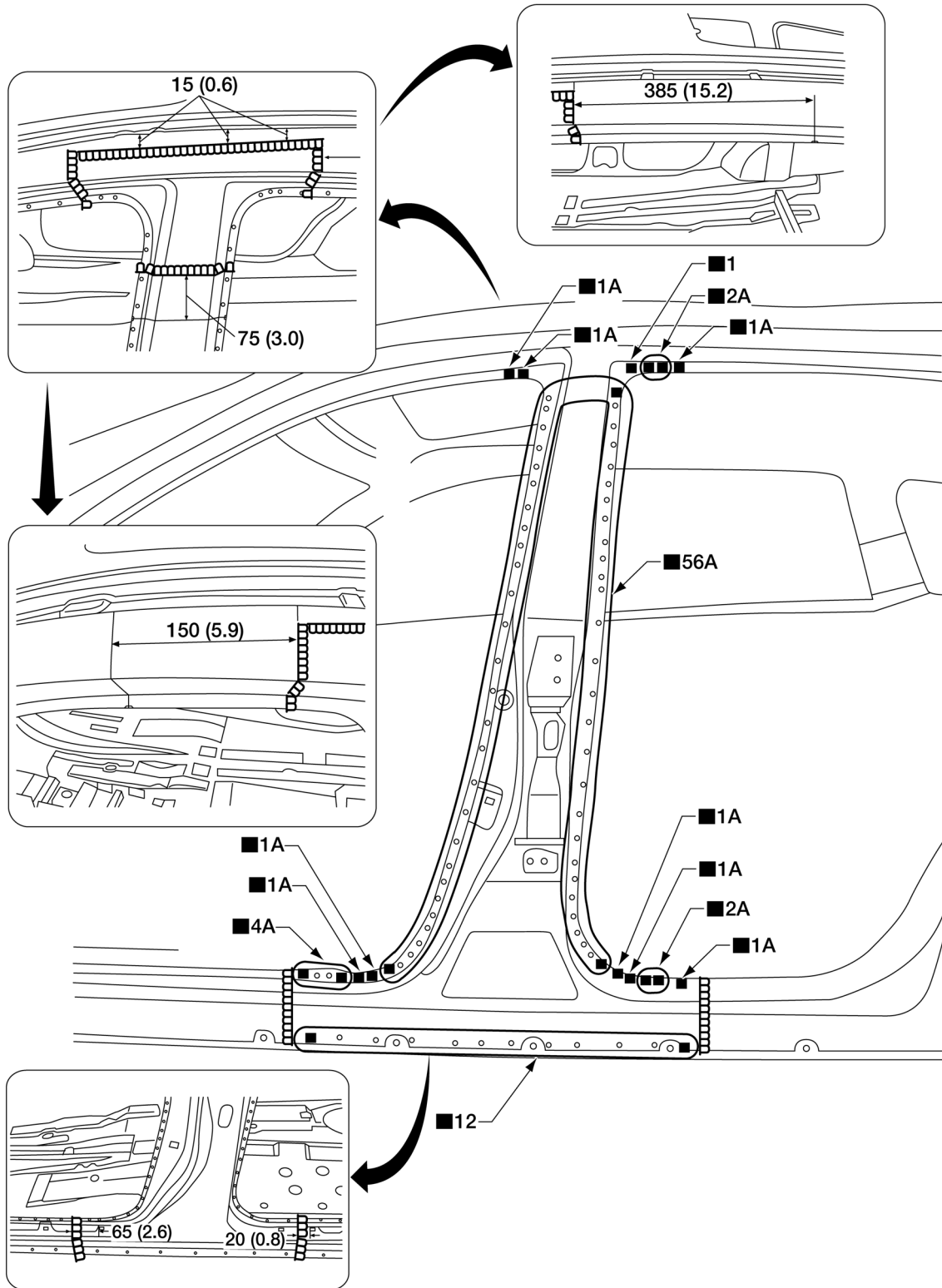

ALKIA2535ZZ

Unit: mm (in)

Replacement parts

- Center pillar portion of front body side outer

## REINFORCEMENT

Work after center pillar portion of front body side outer has been removed.

# REPLACEMENT OPERATIONS

< REMOVAL AND INSTALLATION >

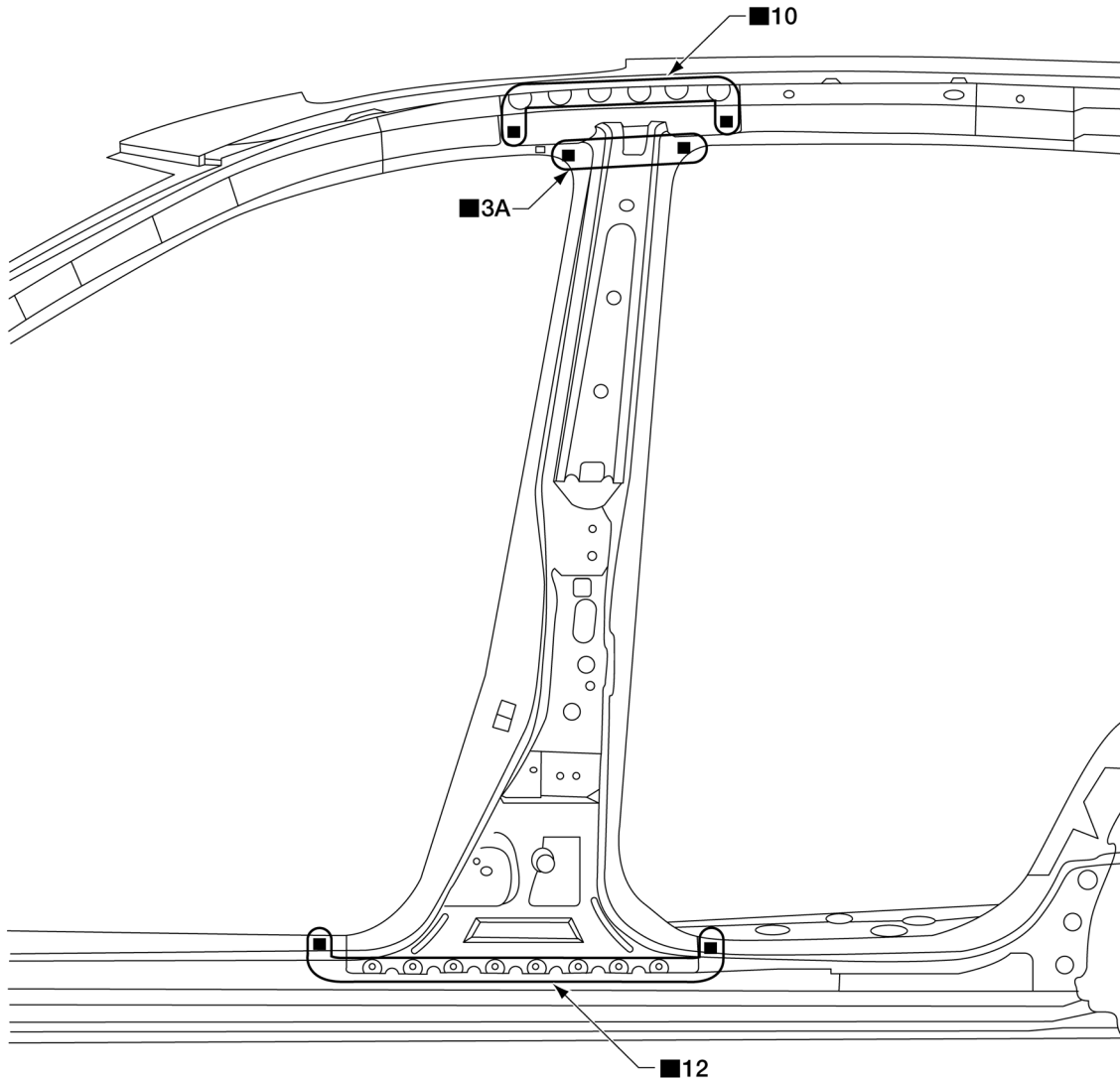

A  
B  
C  
D  
E  
F  
G  
H  
I  
J  
K  
L  
M  
N  
O  
P

**BRM**

ALKIA2452ZZ

Replacement parts

- Center pillar reinforcement

## Outer Sill Reinforcement

INFOID:000000012852563

Work after the front pillar lower hinge brace and the center pillar reinforcement have been removed.

# REPLACEMENT OPERATIONS

< REMOVAL AND INSTALLATION >

---

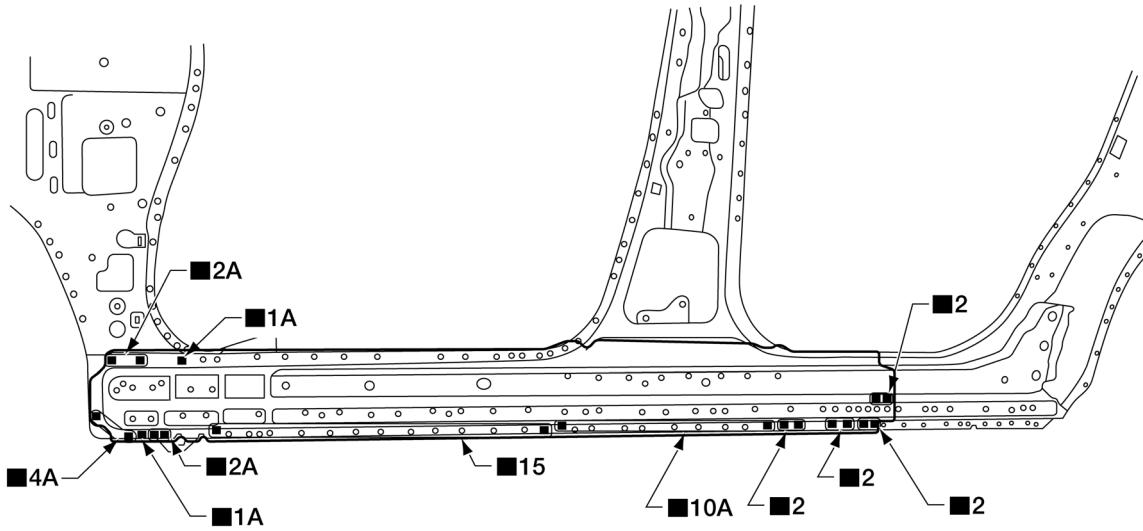

ALKIA2453ZZ

Replacement parts

- Outer sill reinforcement



# REPLACEMENT OPERATIONS

< REMOVAL AND INSTALLATION >

## Rear Fender

INFOID:000000012852564

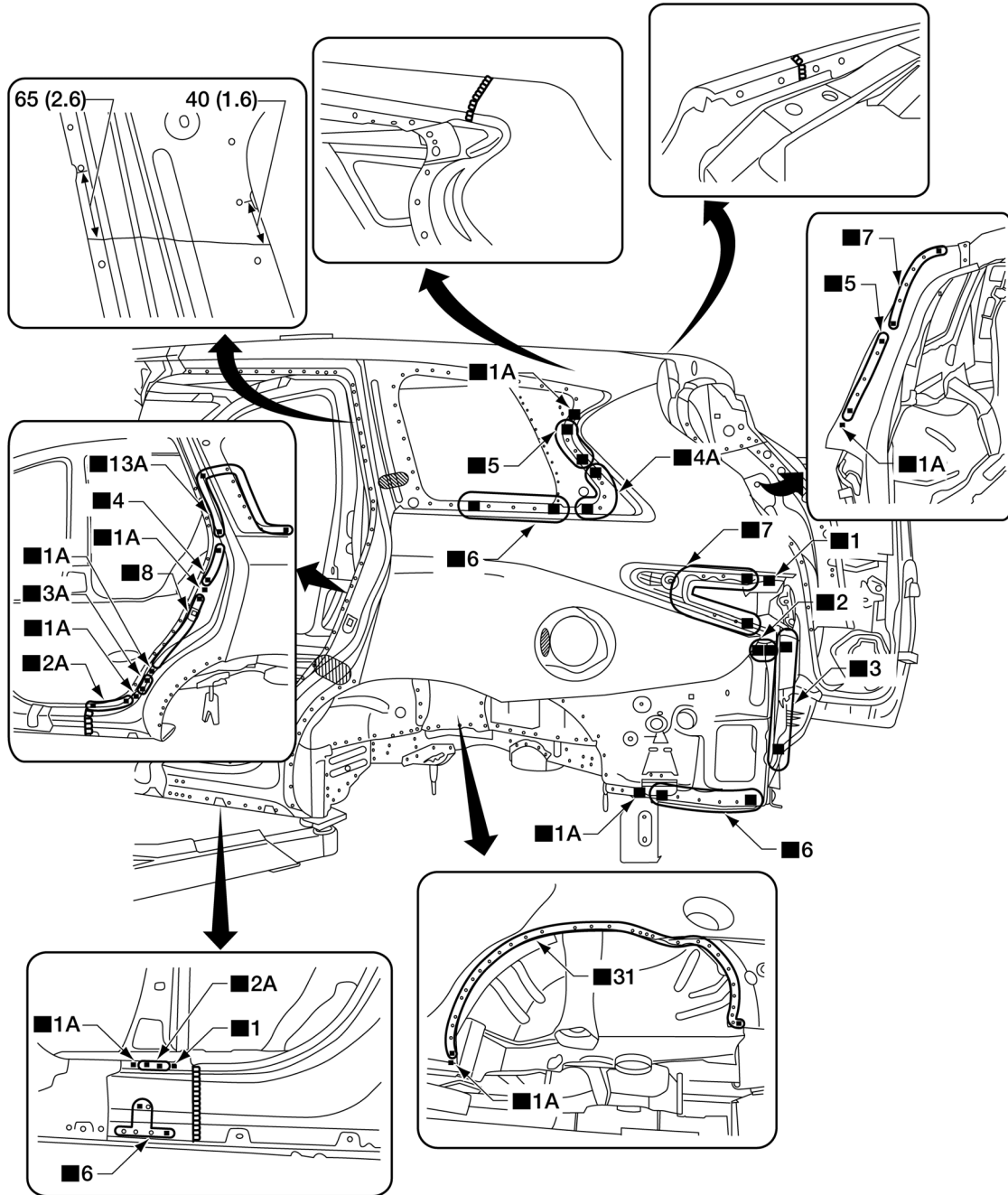

A  
B  
C  
D  
E  
F  
G  
H  
I  
J  
K  
L  
M  
N  
O  
P

BRM

ALKIA2454ZZ

Unit: mm (in)

Replacement parts

- Rear fender

## Rear Body Side Inner Assembly

INFOID:000000012852565

- Work after rear body side outer has been removed.

Revision: April 2016

**BRM-37**

2016 QX60

# REPLACEMENT OPERATIONS

< REMOVAL AND INSTALLATION >

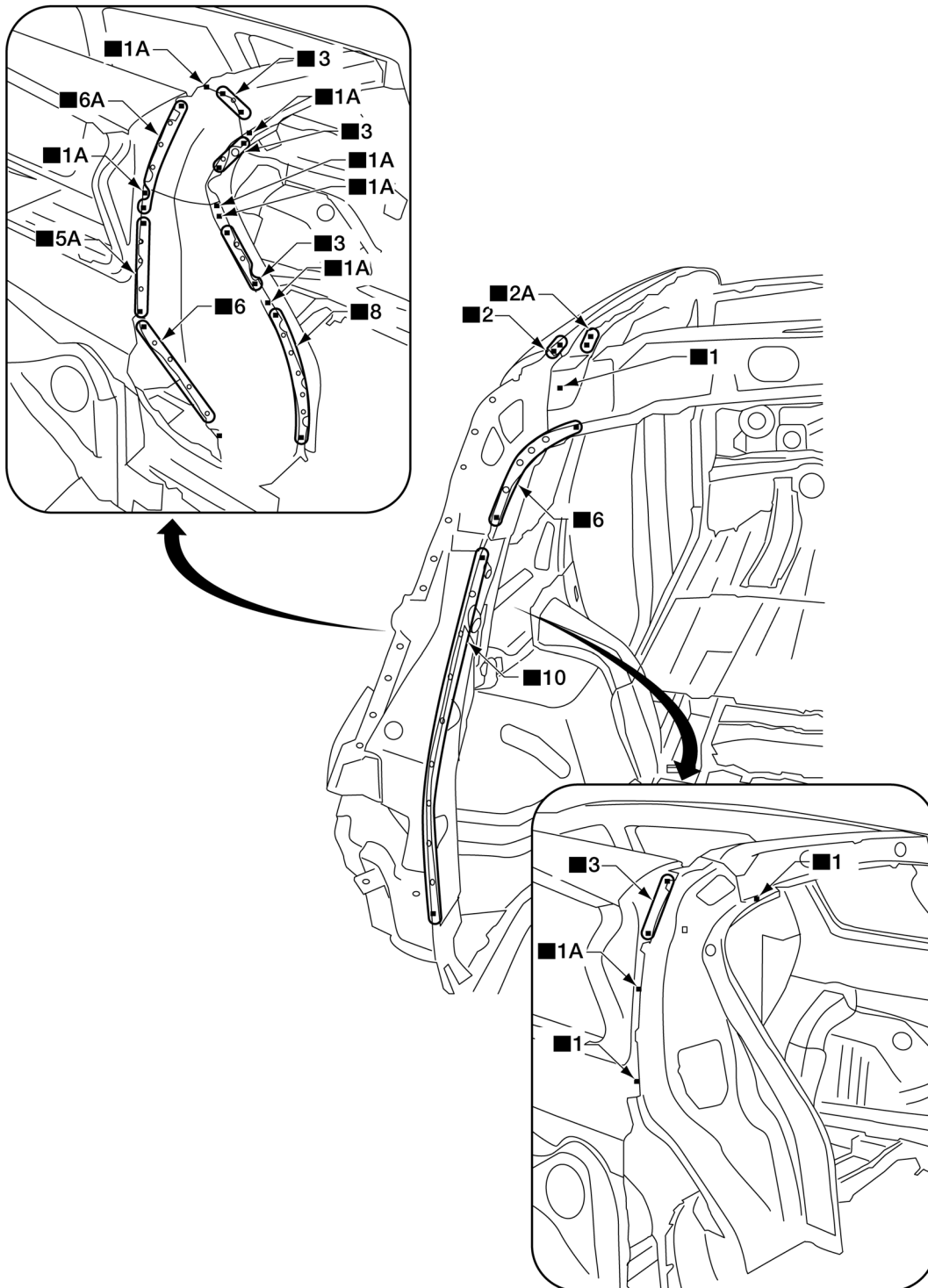

ALKIA2455ZZ

Replacement parts

- Rear pillar assembly

## Rear Floor Rear

INFOID:000000012852566

- Work after rear panel assembly has been removed.

# REPLACEMENT OPERATIONS

< REMOVAL AND INSTALLATION >

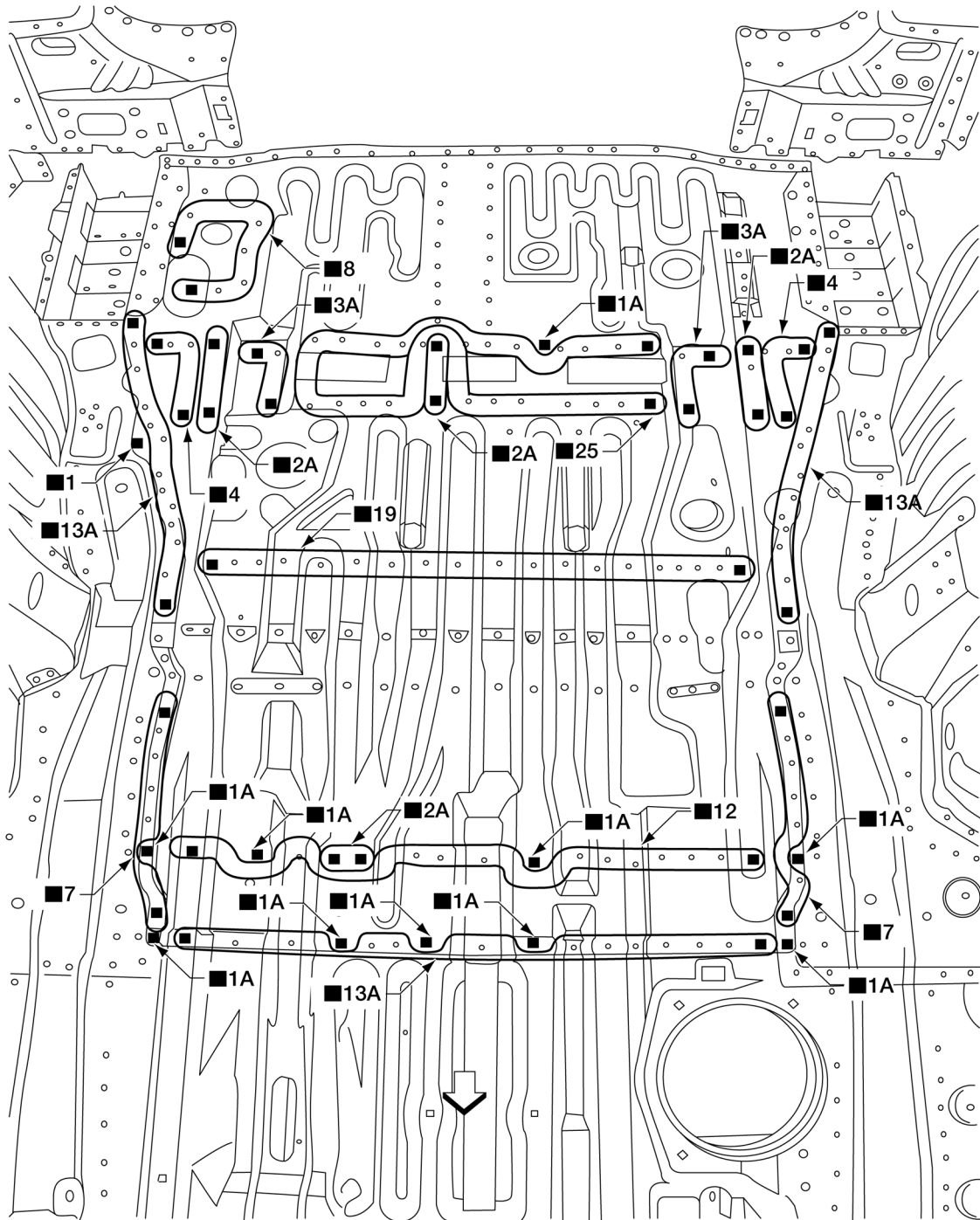

A  
B  
C  
D  
E  
F  
G  
H  
I  
J  
K  
L  
M  
N  
O  
P

BRM

- Replacement parts
- Rear floor rear

ALKIA2456ZZ

# REPLACEMENT OPERATIONS

< REMOVAL AND INSTALLATION >

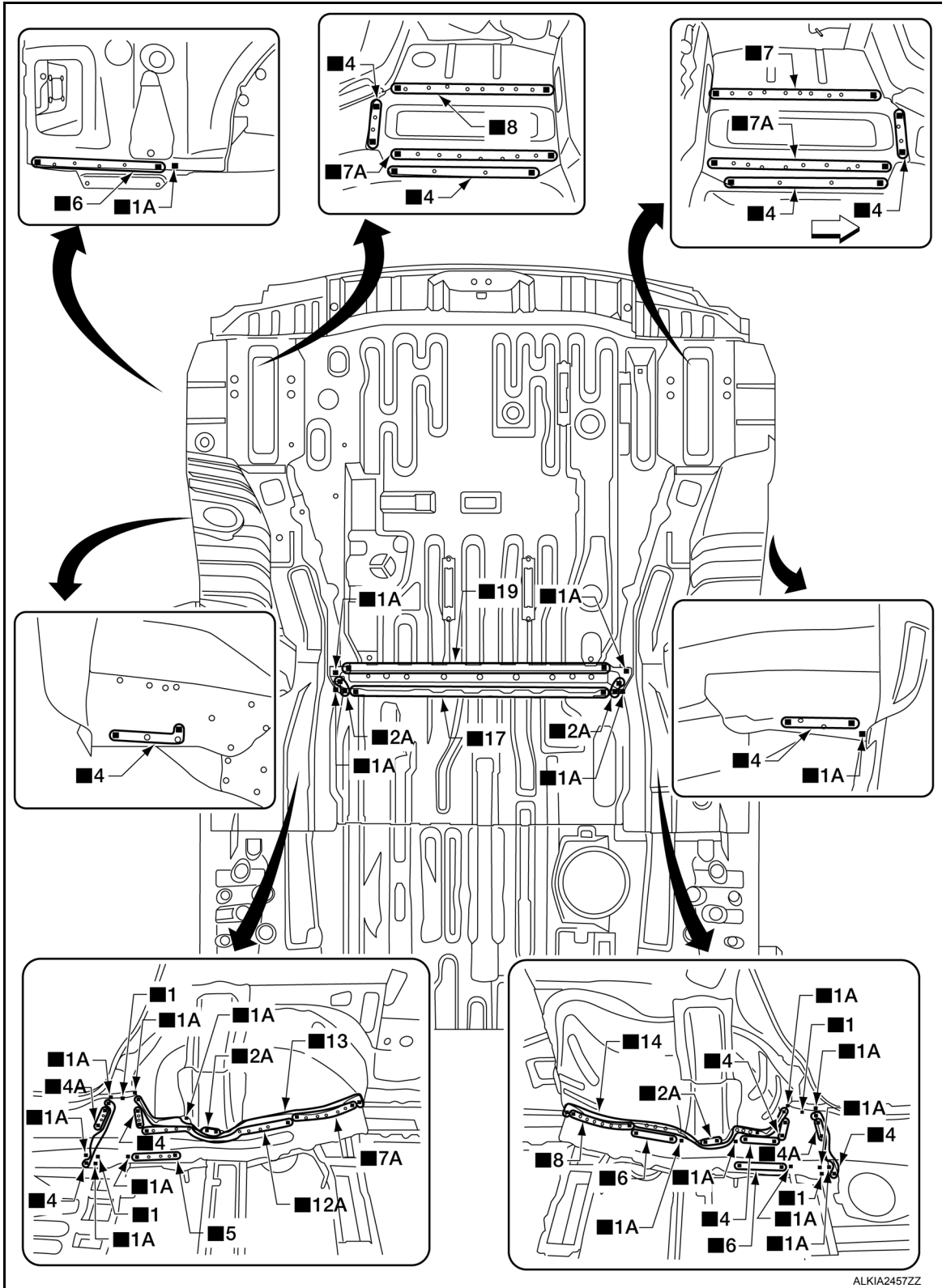

ALKIA2457ZZ

Replacement parts

- Rear side floor (RH, LH)
- Rear floor side assembly (RH, LH)

# REPLACEMENT OPERATIONS

< REMOVAL AND INSTALLATION >

## Rear Panel Assembly

INFOID:000000012852567

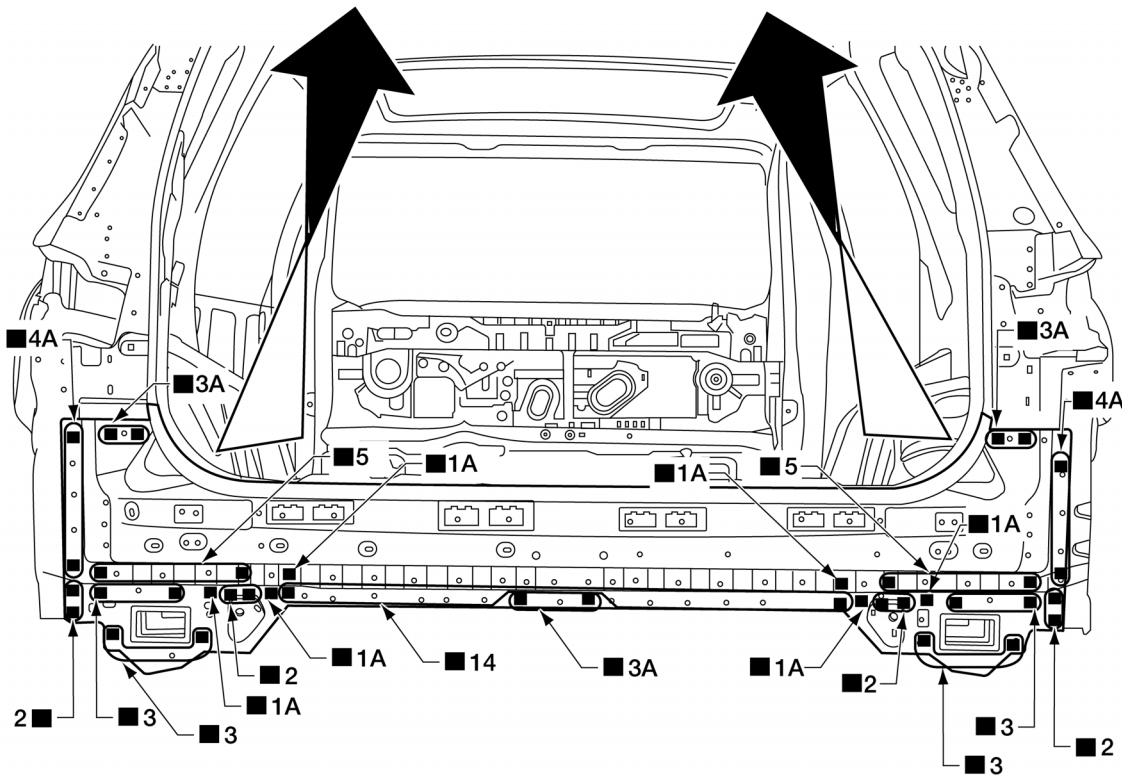
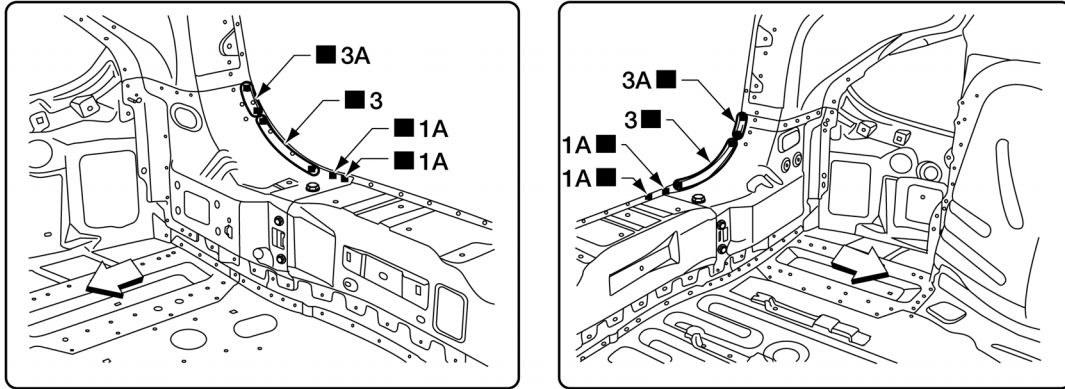

← Front

Replacement parts

- Rear panel assembly

A  
B  
C  
D  
E  
F  
G  
H  
I  
J  
L  
M  
N  
O  
P

BRM

# REPLACEMENT OPERATIONS

< REMOVAL AND INSTALLATION >

Roof

INFOID:000000012852568

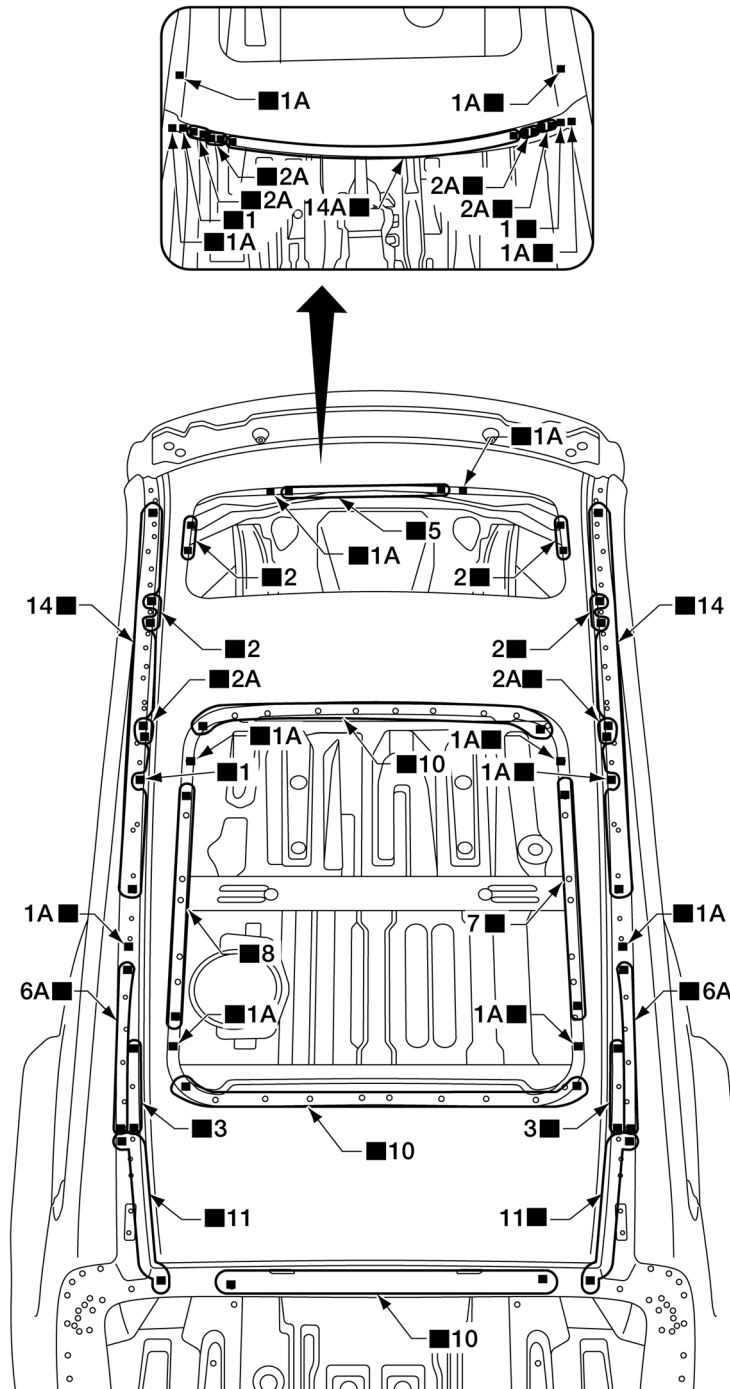

ALKIA2458ZZ

Replacement parts

- Roof panel, panoramic roof shown

## Rear Side Member Extension

INFOID:000000012852569

- Work after rear panel assembly has been removed.

Revision: April 2016

**BRM-42**

2016 QX60

# REPLACEMENT OPERATIONS

< REMOVAL AND INSTALLATION >

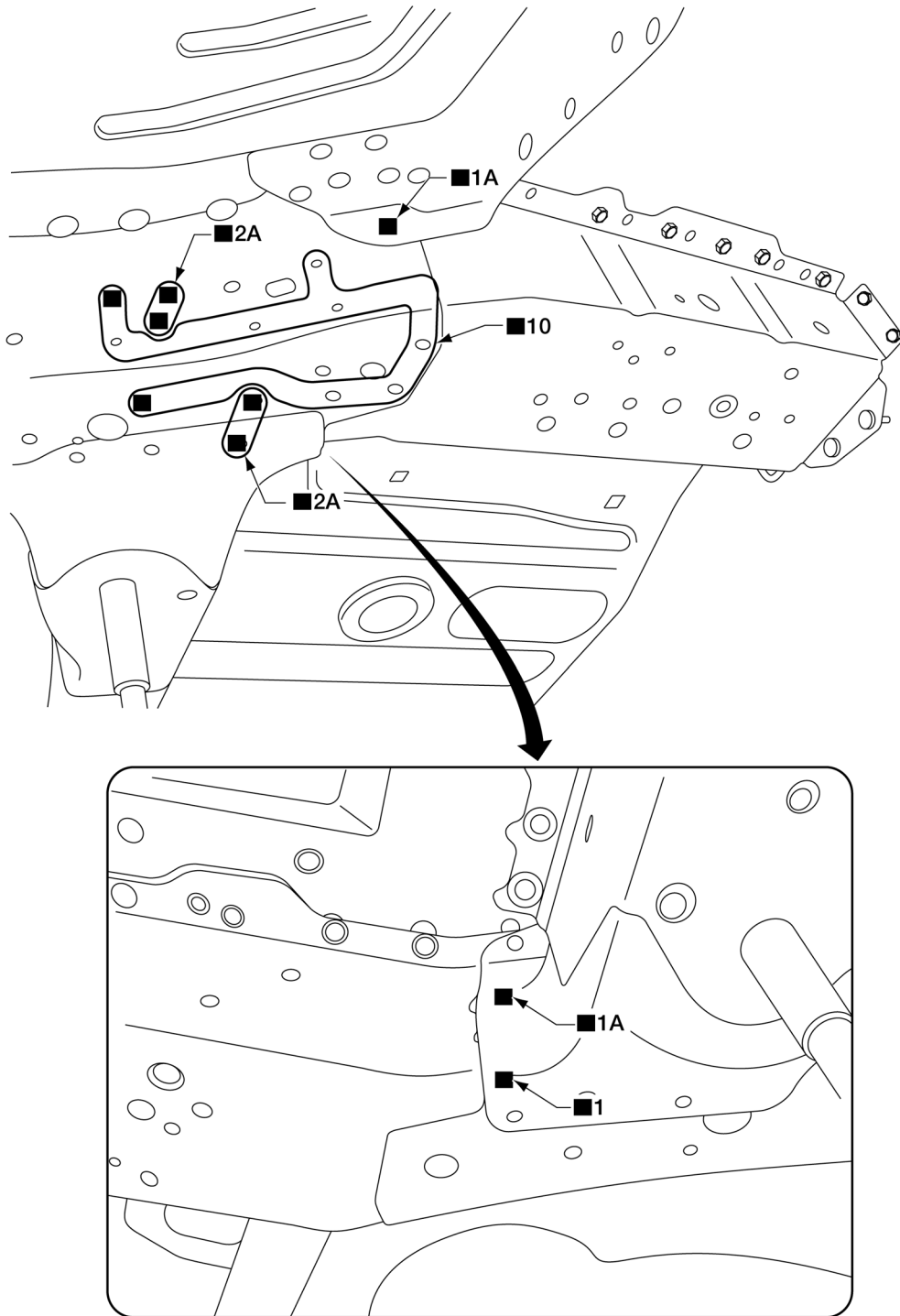

A  
B  
C  
D  
E  
F  
G  
H  
I  
J  
BRM  
L  
M  
N  
O  
P

Replacement parts

- Rear side member extension

ALKIA2459ZZ

# BODY ALIGNMENT

< SERVICE DATA AND SPECIFICATIONS (SDS)

## SERVICE DATA AND SPECIFICATIONS (SDS)

### BODY ALIGNMENT

#### Body Center Marks

INFOID:000000012852570

A mark is placed on each part of the body to indicate the vehicle center. When repairing the vehicle frame (members, pillars, etc.) damaged in an accident the most accurate and effective repair will be achieved by using these marks together with body alignment specifications.

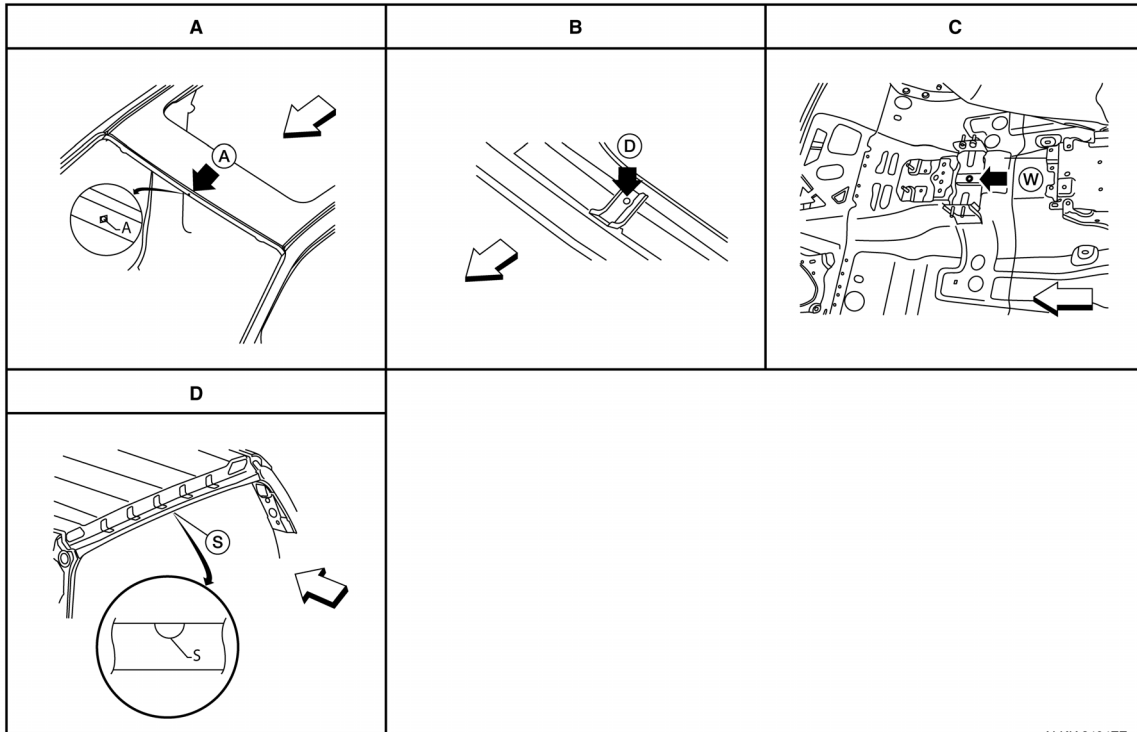
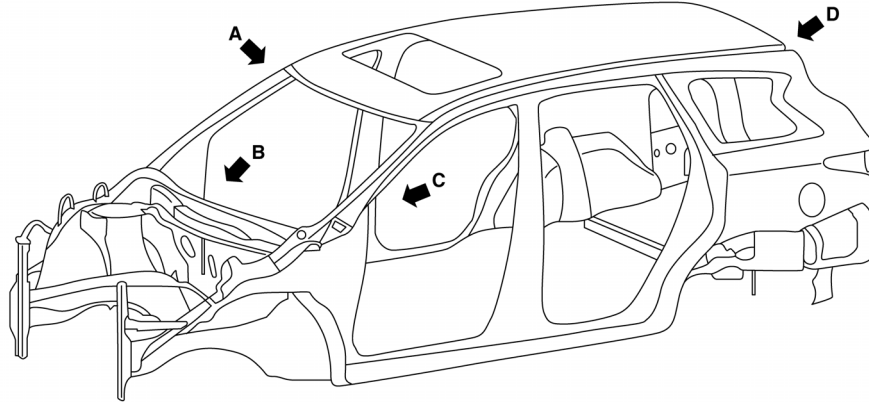

ALKIA2434ZZ

↩ Front

Points	Portion	Marks
A	Front roof	Embossment
D	Center cowl top	Hole
S	Rear roof	Notch
W	Front floor	Hole



# BODY ALIGNMENT

## < SERVICE DATA AND SPECIFICATIONS (SDS)

### Description

INFOID:000000012852571

- All dimensions indicated in the figures are actual.
- When using a tracking gauge, adjust both pointers to equal length. Then check the pointers and gauge itself to make sure there is no free play.
- When a measuring tape is used, check to be sure there is no elongation, twisting or bending.
- Measurements should be taken at the center of the mounting holes.
- An asterisk (\*) following the value at the measuring point indicates that the measuring point on the other side is symmetrically the same value.
- The coordinates of the measurement points are the distances measured from the standard line of "X", "Y" and "Z".
- "Z": Imaginary base line [200 mm (7.87 in) below datum line ("0Z" at design plan)]

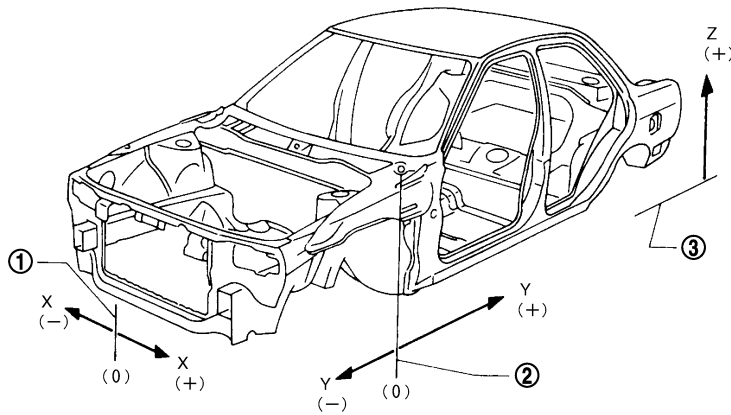

JSKIA0073GB

1. Vehicle center

2. Front axle center

3. Imaginary base line

### Engine Compartment

INFOID:000000012852572

#### MEASUREMENT

Dimensions marked with "\*" indicate symmetrically identical dimensions on both the RH and LH sides of the vehicle.

A  
B  
C  
D  
E  
F  
G  
H  
I  
J  
L  
M  
N  
O  
P

BRM

# BODY ALIGNMENT

< SERVICE DATA AND SPECIFICATIONS (SDS)

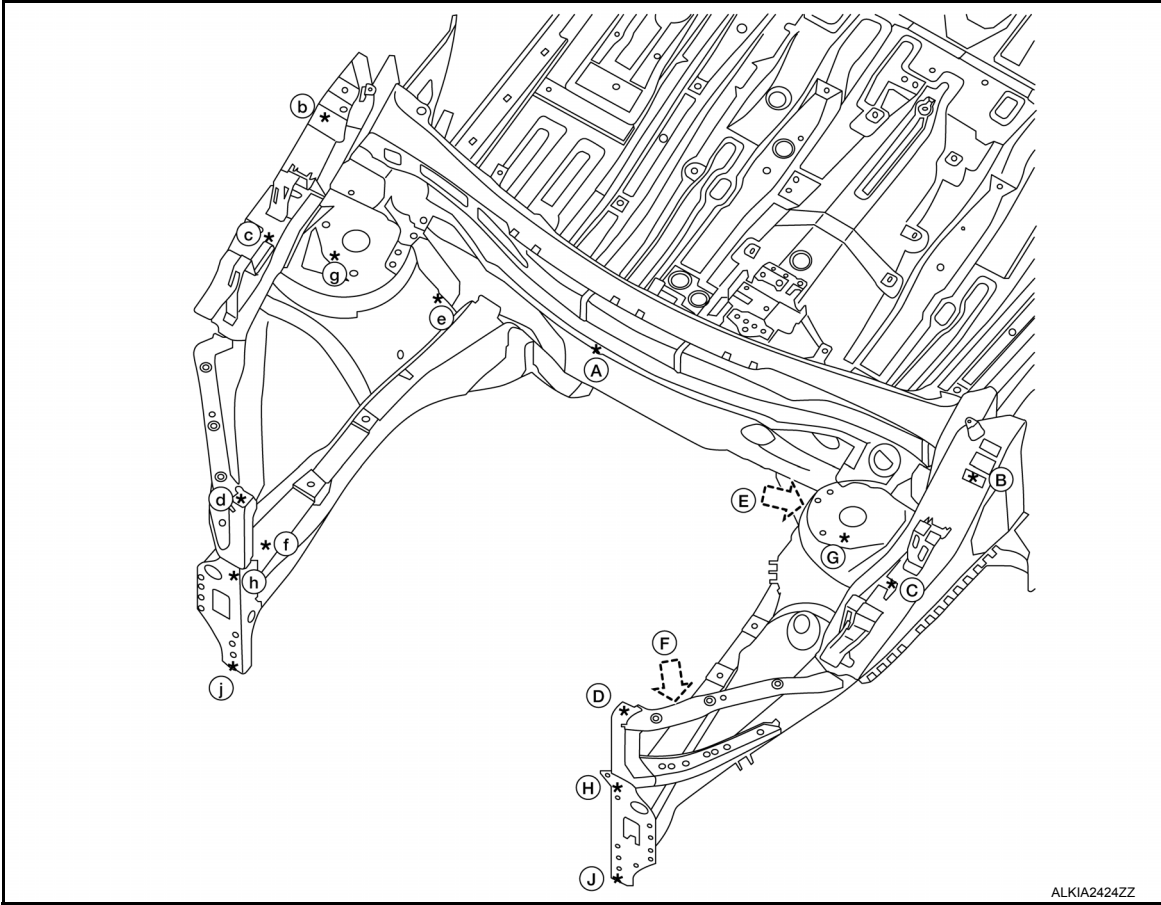

ALKIA2424ZZ

Unit: mm (in)

Coordinate	Measurement	Coordinate	Measurement	Coordinate	Measurement
A - B	885.69 (34.87)	A - b	787.34 (31.00)	A - C	852.49 (33.56)
A - c	754.18 (29.69)	A - D	889.39 (35.02)	A - d	832.96 (32.79)
A - F	889.73 (35.03)	A - f	832.25 (32.77)	A - g	607.62 (23.92)
B - b	1646.00 (64.80)	B - d*	1556.61 (61.28)	b - d*	907.20 (35.72)
C - c	1580.02 (62.21)	D - d	972.02 (38.27)	D - e*	1291.38 (50.84)
D - f*	1035.90 (40.78)	D - G*	623.77 (24.56)	E - e	1022.82 (40.27)
E - f*	1217.08 (47.92)	G - g	1296.08 (51.03)	H - h	974.00 (38.35)
H - j*	1038.02 (40.87)	J - j	981.02 (38.62)		

## MEASUREMENT POINTS

# BODY ALIGNMENT

< SERVICE DATA AND SPECIFICATIONS (SDS)

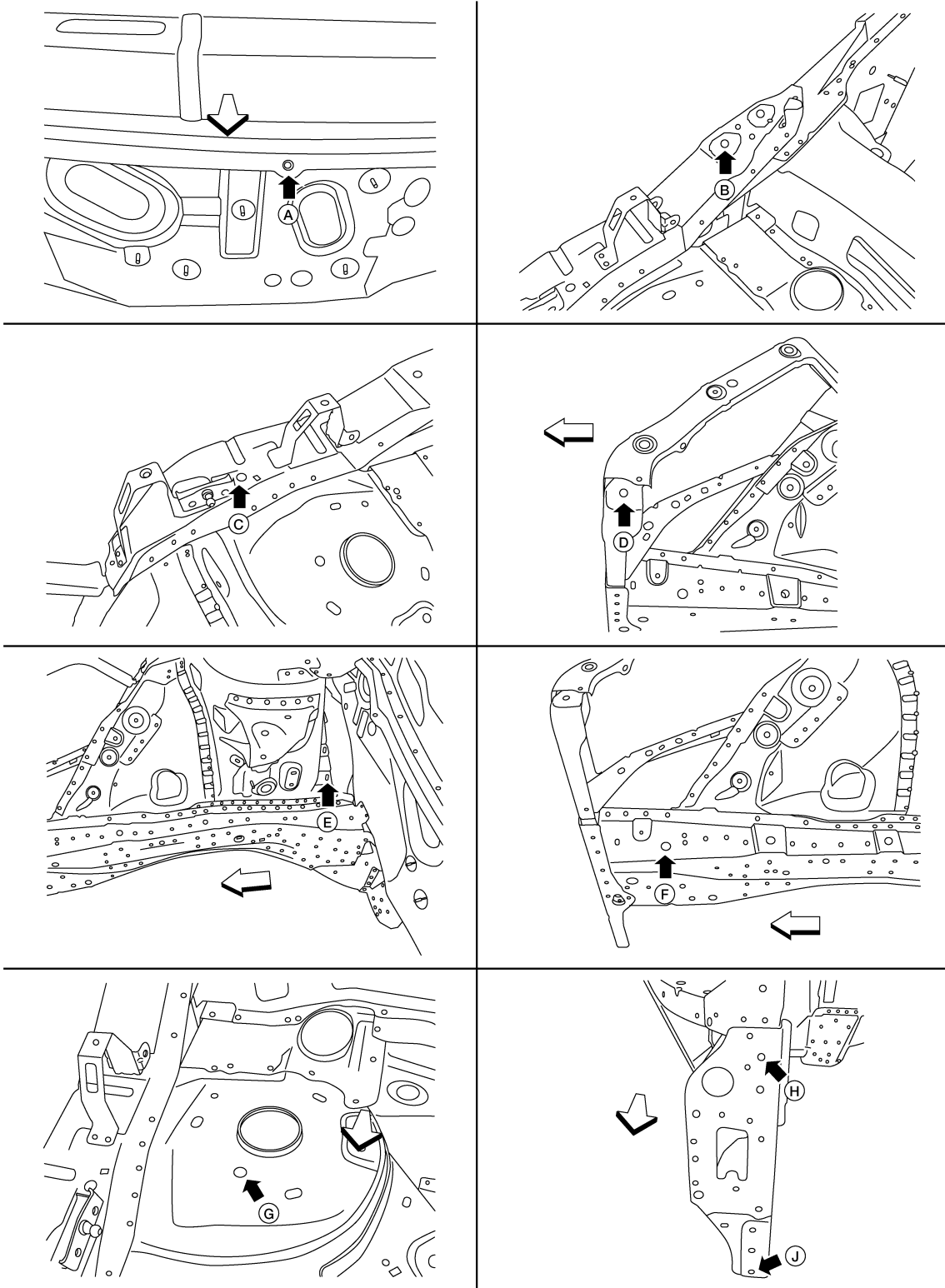

A  
B  
C  
D  
E  
F  
G  
H  
I  
J  
BRM  
L  
M  
N  
O  
P

AWKIA2669ZZ

← Front

Unit: mm (in)

Point	Description
A	Center of cowl top hole 5.5 (0.22)
B, b	Hood hinge installing hole center 7.0 (0.28)
C, c	Hoodledge hole

# BODY ALIGNMENT

## < SERVICE DATA AND SPECIFICATIONS (SDS)

Point	Description
D, d	Side radiator core support hole center 7.0 (0.28)
E, e	Rear lower hoodledge hole 12.0 x 7.0 (0.47 x 0.28)
F, f	Front side member hole center 16.0 (0.63)
G, g	Rear lower hoodledge hole 12.0 (0.47)
H, h	Front side member connector upper hole 8.0 (0.31)
J, j	Front side member connector lower hole 7.0 (0.28)

## Underbody

INFOID:0000000012852573

## MEASUREMENT

The following figure shows a bottom view and a side view of the vehicle.

# BODY ALIGNMENT

< SERVICE DATA AND SPECIFICATIONS (SDS)

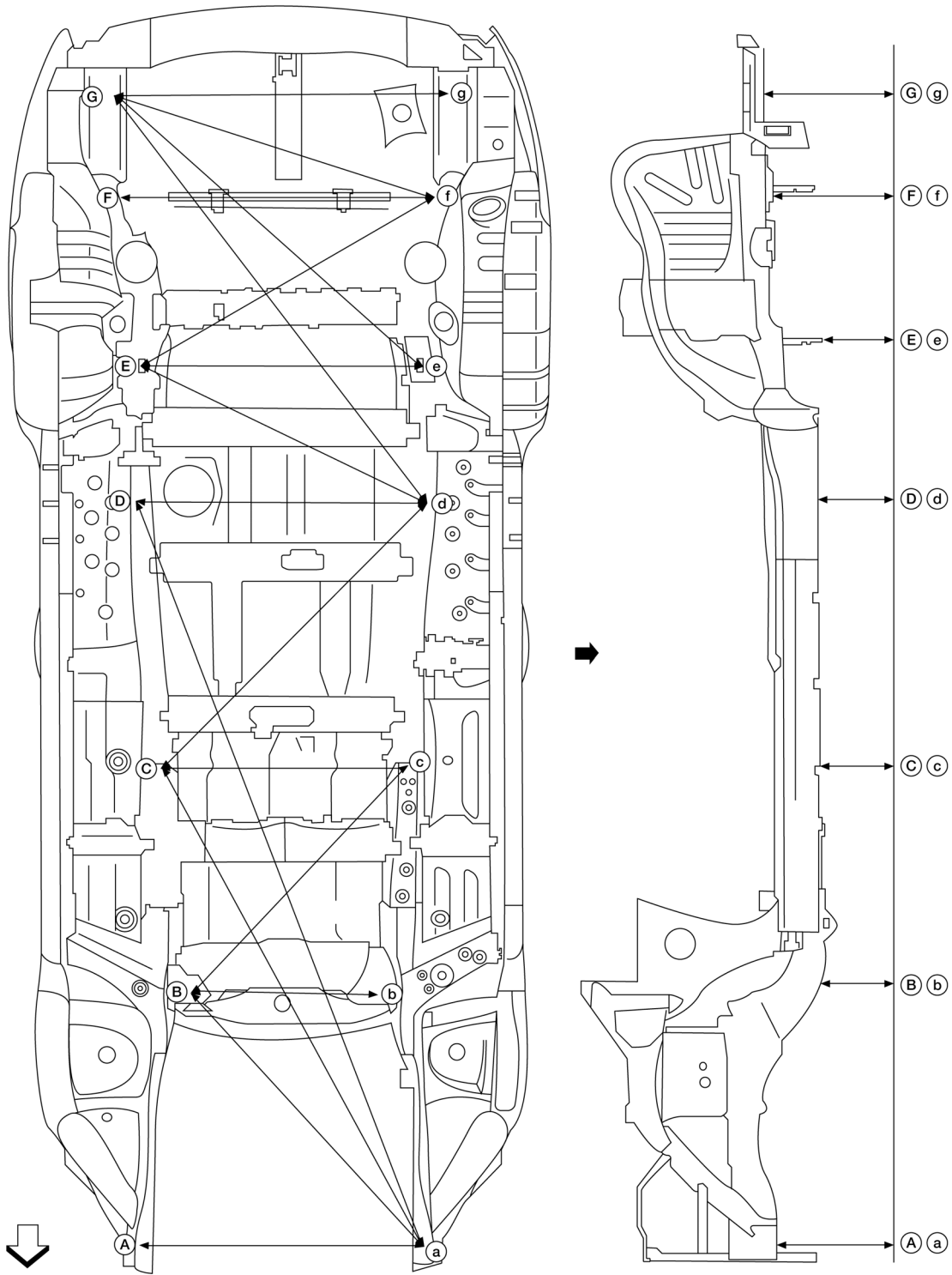

← Front

← Vehicle left side

ALKIA2435ZZ

Unit: mm (in)

Coordinates	Measurement	Coordinates	Measurement	Coordinates	Measurement
A-a	994.10 (39.14)	a-B*	1271.61 (50.00)	a-C*	2005.56 (78.96)
A-d*	2908.27 (114.50)	B-b	654.04 (25.75)	B-c*	1119.19 (44.06)

A  
B  
C  
D  
E  
F  
G  
H  
I  
J  
K  
L  
M  
N  
O  
P

**BRM**

# BODY ALIGNMENT

## < SERVICE DATA AND SPECIFICATIONS (SDS)

Coordinates	Measurement	Coordinates	Measurement	Coordinates	Measurement
C-c	847.12 (33.35)	C-d*	1351.85 (53.22)	D-d	1027.90 (40.47)
d-E*	1142.51 (44.98)	D-g*	1845.85 (72.67)	E-e	1002.00 (39.45)
E-f*	1235.80 (48.65)	e-G*	1470.80 (57.91)	F-f	1130.19 (44.50)
F-f	1130.19 (44.50)	f-G*	1216.41 (47.89)	G-g	1187.54 (46.76)

Dimensions marked with "\*" indicate symmetrically identical dimensions on both the RH and LH sides of the vehicle.

## MEASUREMENT POINTS

# BODY ALIGNMENT

< SERVICE DATA AND SPECIFICATIONS (SDS)

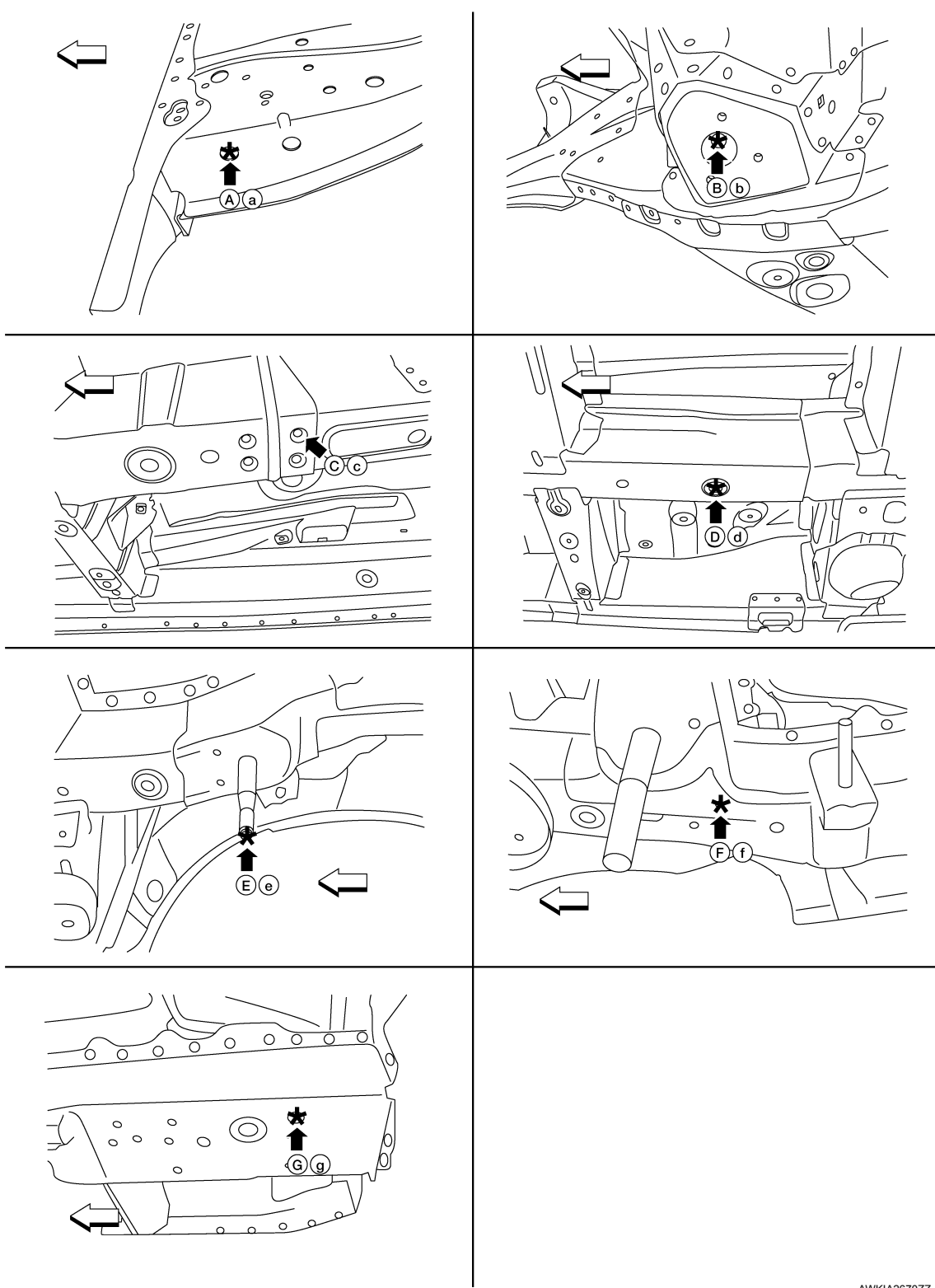

A  
B  
C  
D  
E  
F  
G  
H  
I  
J  
K  
L  
M  
N  
O  
P

BRM

← Front

AWKIA2670ZZ

Unit: mm (in)

Points	Coordinates			Remarks
	X	Y	Z	
A, a	±497.00 (±19.57)	±555.50 (-12.87)	330.00 (12.99)	Hole 12.00 (0.47)
B, b	±327.00 (±12.87)	395.89 (15.59)	143.80 (5.66)	Hole 12.00 (0.47)

# BODY ALIGNMENT

## < SERVICE DATA AND SPECIFICATIONS (SDS)

Points	Coordinates			Remarks
	X	Y	Z	
C, c	±437.06 (±17.21)	1212.19 (47.72)	171.93 (6.77)	Hole 9.00 (0.35)
D, d	±513.95 (±20.23)	1270.09 (50.00)	154.00 (6.06)	Hole 18.00×16.00 (0.71×0.63)
E, e	±501.0 (±19.72)	2683.00 (105.63)	135.90 (5.35)	Center of stud end
F, f	±556.09 (±21.89)	3273.92 (128.89)	336.33 (13.24)	Hole 10.00 ×8.00 (0.36 x 0.31)
G, g	±593.79 (±23.38)	3643.54 (143.45)	340.93 (13.42)	Hole 11 (0.43)

### Passenger Compartment

INFOID:0000000012852574

### MEASUREMENT

Dimensions marked with "\*" indicate symmetrically identical dimensions on both the LH and RH side of the vehicle.

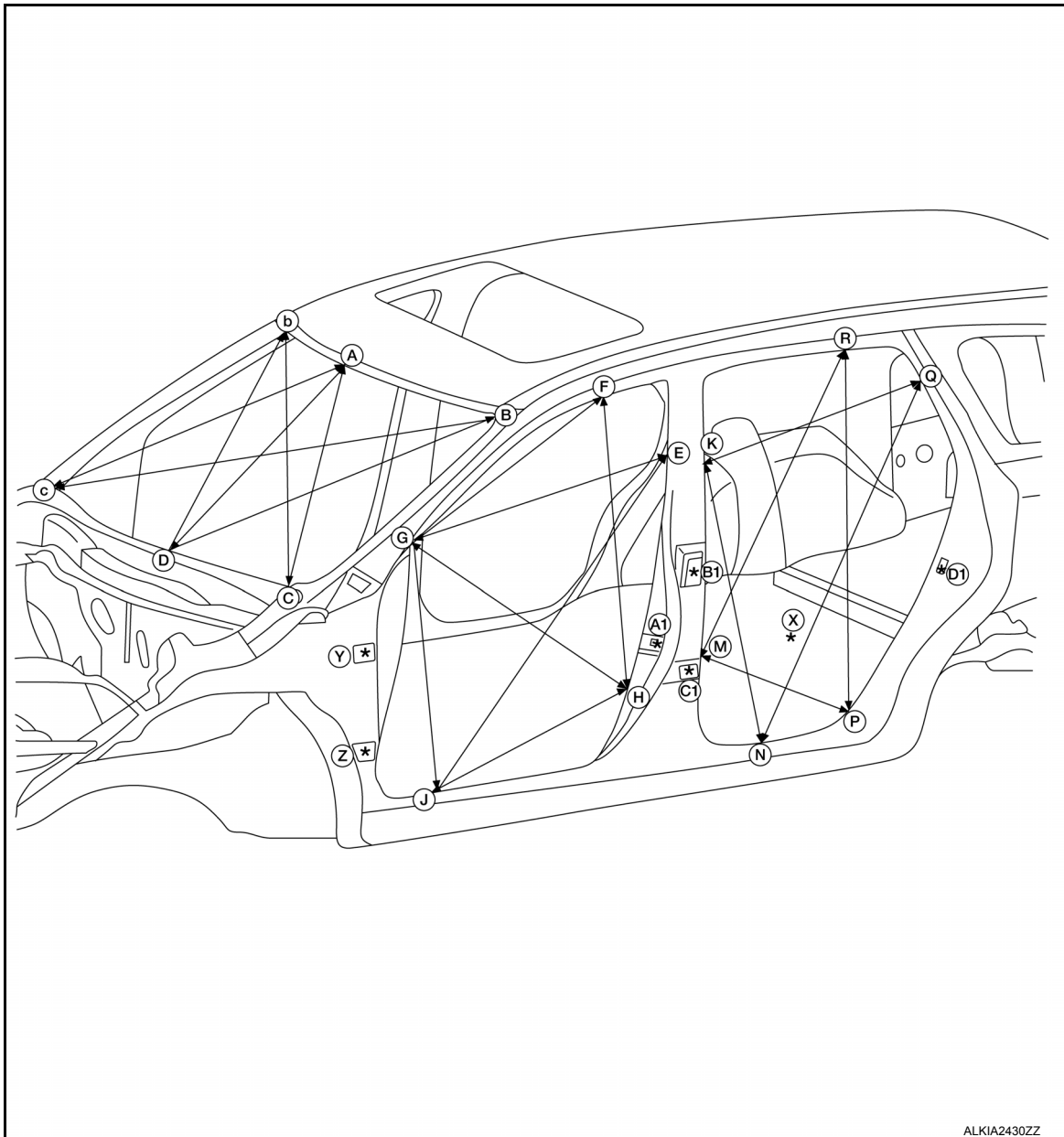

ALKIA2430ZZ



# BODY ALIGNMENT

## < SERVICE DATA AND SPECIFICATIONS (SDS)

Unit: mm (in)

Coordinates	Measurement	Coordinates	Measurement	Coordinates	Measurement
A-C*	1070.63 (42.15)	A-D	855.50 (34.86)	C-b*	1611.94 (63.46)
D-B*	1138.82 (44.84)	E-J*	1256.45 (49.47)	F-H*	898.75 (35.38)
G-E*	910.84 (35.86)	G-F*	753.15 (29.65)	G-H*	932.50 (36.71)
G-J*	807.46 (31.79)	J-H*	686.20 (27.02)	K-N*	992.54 (39.08)
K-Q*	765.81 (30.15)	M-P*	593.58 (23.37)	M-R*	1091.02 (42.95)
Q-N*	1207.16 (47.53)	R-P*	1094.92 (43.11)	Y-D1*	2101.67 (82.74)
A1-D1*	1044.44 (41.12)	A1-Y*	1079.32 (42.49)	A1-Z*	1074.30 (42.30)
B1-D1*	917.80 (36.13)	C1-D1	976.50 (38.44)	R-X	1303.24 (51.31)
r-X	1257.45 (49.51)	K-X	1355.65 (53.37)	k-X	1305.74 (51.41)
Q-X	1249.05 (49.18)	q-X	1197.86 (47.16)*	W-F*	1474.34 (58.04)
W-E*	1529.04 (60.20)*	W-G	1090.94 (42.95)		

### MEASUREMENT POINTS

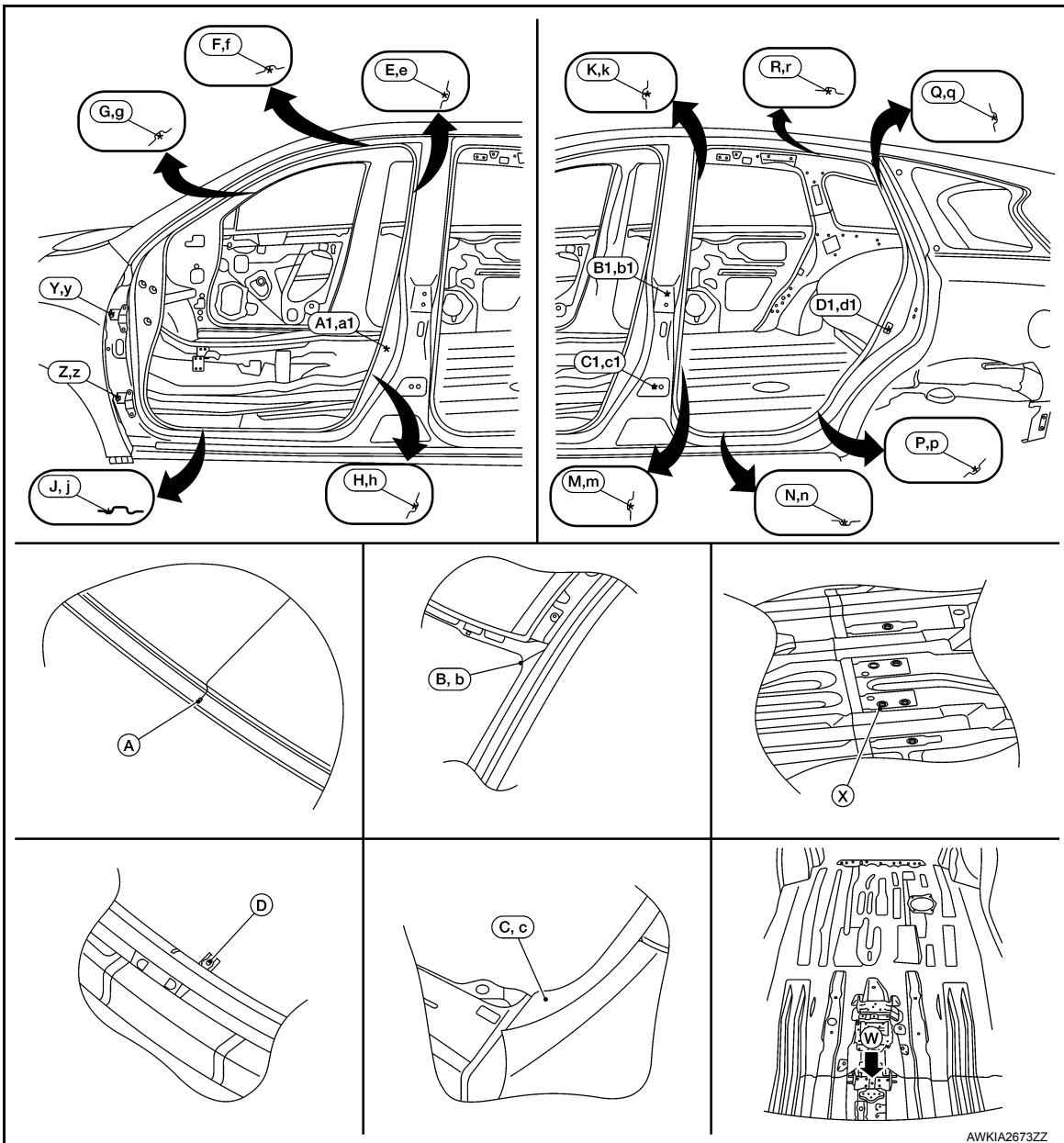

AWKIA2673ZZ

# BODY ALIGNMENT

## < SERVICE DATA AND SPECIFICATIONS (SDS)

↶ Front

Point	Description	Point	Description
A	Roof flange end of center positioning mark	P, p, Q, q	Rear fender indent
B, b, F, f, R, r	Outer side body joggle	W	Center of front floor positioning mark
C, c	Outer side body indent	X	Center of rear floor front positioning mark
D	Center of center cowl top hole	E, e, H, h, J, j, K, k, M, m	Center pillar indent
G, g	Front pillar indent	Y, y, Z, z, B1, b1, C1, c1	Door hinge installing hole center
A1,a1, D1,d1	Door switch bolt hole		

### Rear Body

INFOID:0000000012852575

### MEASUREMENT

Dimensions marked with "\*" indicate symmetrically identical dimensions on both the LH and RH side of the vehicle.

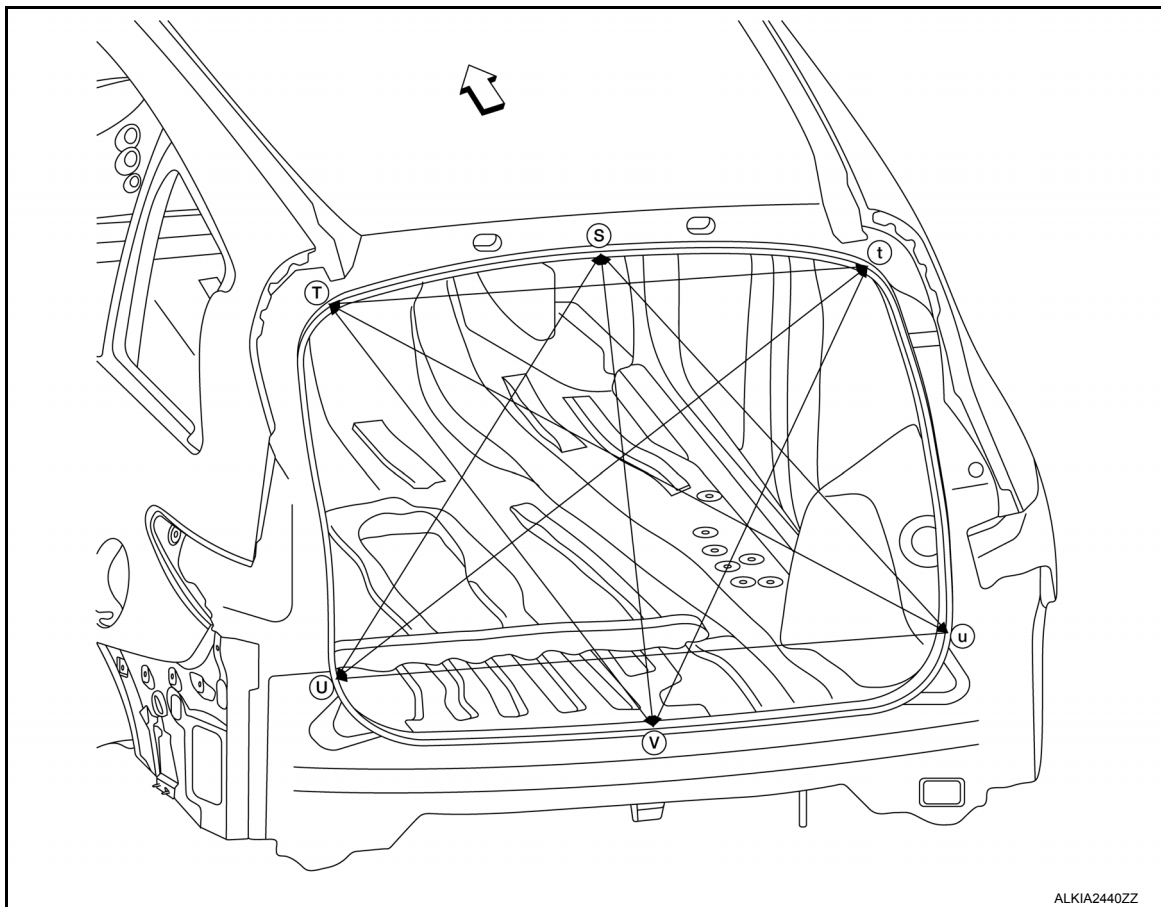

ALKIA2440ZZ

↶ Front

Unit: mm (in)

Coordinates	Measurement	Coordinates	Measurement	Coordinates	Measurement
S - V	940.73 (37.04)	S - U*	1004.59 (39.55)	V - T*	1039.81 (40.94)
T - u*	1370.89 (53.97)	T - t	1079.60 (42.50)	U - u	1228.10 (48.35)

### MEASUREMENT POINTS

# BODY ALIGNMENT

< SERVICE DATA AND SPECIFICATIONS (SDS)

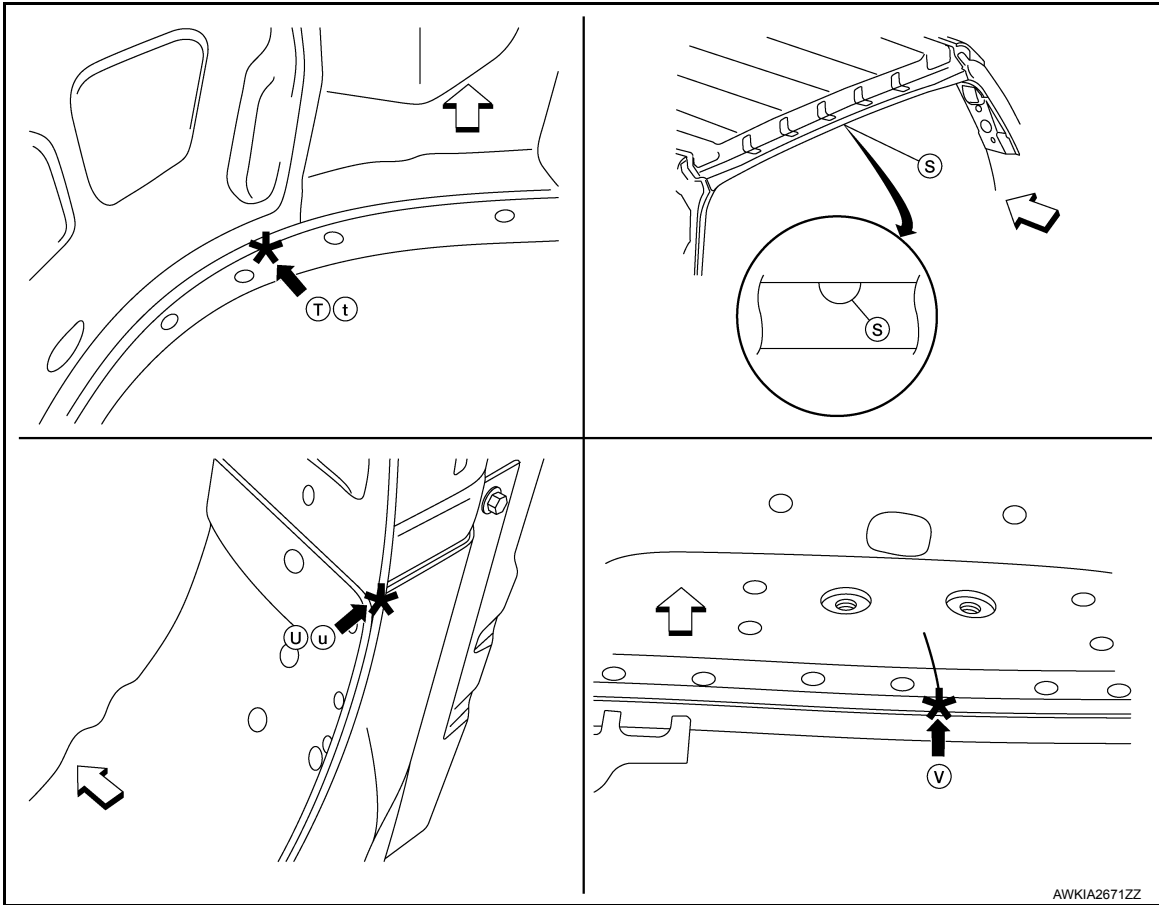

↩ Front

Point	Description	Point	Description
S	Roof flange end of center positioning mark	T, t	Back pillar main joggle
U, u	Upper rear panel joggle	V	Edge of rear panel between back door striker installing holes

A  
B  
C  
D  
E  
F  
G  
H  
I  
J  
L  
M  
N  
O  
P

BRM