

SECTION **FAX**
FRONT AXLE

A
B
C

FAX

CONTENTS

E

PRECAUTION	2	FRONT DRIVE SHAFT BOOT	10	F
PRECAUTIONS	2	Exploded View	10	
Precaution for Supplemental Restraint System (SRS) "AIR BAG" and "SEAT BELT PRE-TENSIONER"	2	WHEEL SIDE	11	G
Precautions for Drive Shaft	2	WHEEL SIDE : Removal and Installation	11	
PREPARATION	3	TRANSAXLE SIDE	14	H
PREPARATION	3	TRANSAXLE SIDE : Removal and Installation	14	
Special Service Tool	3	Inspection	14	
Commercial Service Tool	3	FRONT DRIVE SHAFT	15	I
SYMPTOM DIAGNOSIS	5	Exploded View (LH)	15	
NOISE, VIBRATION AND HARSHNESS (NVH) TROUBLESHOOTING	5	Removal and Installation (LH)	15	J
NVH Troubleshooting Chart	5	Exploded View (RH)	17	
PERIODIC MAINTENANCE	6	Removal and Installation (RH)	17	
FRONT WHEEL HUB	6	UNIT DISASSEMBLY AND ASSEMBLY ...	20	K
Inspection	6	FRONT DRIVE SHAFT	20	L
FRONT DRIVE SHAFT	7	Disassembly and Assembly (LH)	20	
Inspection	7	Disassembly and Assembly (RH)	25	
REMOVAL AND INSTALLATION	8	SERVICE DATA AND SPECIFICATIONS (SDS)	31	M
FRONT WHEEL HUB	8	SERVICE DATA AND SPECIFICATIONS (SDS)	31	N
Exploded View	8	Wheel Bearing	31	
Removal and Installation	8	Drive Shaft	31	O
		Dynamic Damper	31	
		Boot Bands	32	P

PRECAUTIONS

< PRECAUTION >

PRECAUTION

PRECAUTIONS

Precaution for Supplemental Restraint System (SRS) "AIR BAG" and "SEAT BELT PRE-TENSIONER"

INFOID:000000009711909

The Supplemental Restraint System such as "AIR BAG" and "SEAT BELT PRE-TENSIONER", used along with a front seat belt, helps to reduce the risk or severity of injury to the driver and front passenger for certain types of collision. This system includes dual stage front air bag modules. The SRS system may only deploy one front air bag, depending on the severity of a collision and whether the front passenger seat is occupied. Information necessary to service the system safely is included in the SR and SB section of this Service Manual.

WARNING:

- To avoid rendering the SRS inoperative, which could increase the risk of personal injury or death in the event of a collision which would result in air bag inflation, all maintenance must be performed by an authorized NISSAN/INFINITI dealer.
- Improper maintenance, including incorrect removal and installation of the SRS, can lead to personal injury caused by unintentional activation of the system. For removal of Spiral Cable and Air Bag Module, see the SR section.
- Do not use electrical test equipment on any circuit related to the SRS unless instructed to in this Service Manual. SRS wiring harnesses can be identified by yellow and/or orange harnesses or harness connectors.

PRECAUTIONS WHEN USING POWER TOOLS (AIR OR ELECTRIC) AND HAMMERS

WARNING:

- When working near the Airbag Diagnosis Sensor Unit or other Airbag System sensors with the Ignition ON or engine running, DO NOT use air or electric power tools or strike near the sensor(s) with a hammer. Heavy vibration could activate the sensor(s) and deploy the air bag(s), possibly causing serious injury.
- When using air or electric power tools or hammers, always switch the Ignition OFF, disconnect the battery and wait at least three minutes before performing any service.

Precautions for Drive Shaft

INFOID:000000009135435

Observe the following precautions when disassembling and assembling drive shaft.

- Joint sub-assembly does not disassemble because it is non-overhaul parts.
- Perform work in a location which is as dust-free as possible.
- Before disassembling and assembling, clean the outside of parts.
- Prevention of the entry of foreign objects must be taken into account during disassembly of the service location.
- Disassembled parts must be carefully reassembled in the correct order. If work is interrupted, a clean cover must be placed over parts.
- Paper shop cloths must be used. Fabric shop cloths must not be used because of the danger of lint adhering to parts.
- Disassembled parts (except for rubber parts) should be cleaned with kerosene which shall be removed by blowing with air or wiping with paper shop cloths.

PREPARATION

< PREPARATION >

PREPARATION

PREPARATION

Special Service Tool

INFOID:000000009135436

The actual shapes of Kent-More tools may differ from those of special service tools illustrated here.

Tool number (Kent-More No.) Tool name	Description
KV40107300 (—) Boot band crimping tool	Installing boot band
KV40107500 (—) Drive shaft attachment	Removing drive shaft
KV38107900 (—) Protector a: 32 mm (1.26 in) dia.	Installing drive shaft

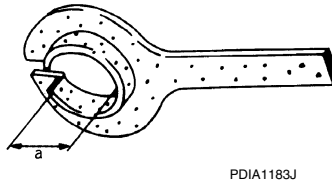
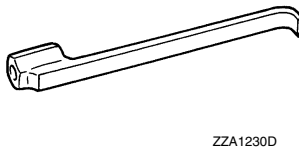
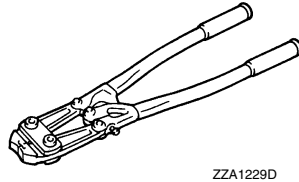

Commercial Service Tool

INFOID:000000009135437

Tool name	Description
Drive shaft puller	Removing drive shaft joint sub assembly

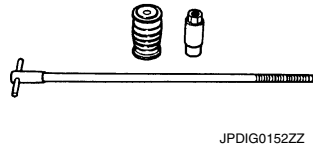

PREPARATION

< PREPARATION >

Sliding hammer

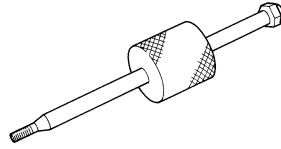

ZZA0023D

Removing drive shaft

Power tool



PIIB1407E

Loosening nuts, screws and bolts

NOISE, VIBRATION AND HARSHNESS (NVH) TROUBLESHOOTING

< SYMPTOM DIAGNOSIS >

SYMPTOM DIAGNOSIS

NOISE, VIBRATION AND HARSHNESS (NVH) TROUBLESHOOTING

NVH Troubleshooting Chart

INFOID:000000009135438

Use chart below to find the cause of the symptom. If necessary, repair or replace these parts.

Reference			—	FAX-7, "Inspection"	—	FAX-8, "Exploded View"	—	FAX-6, "Inspection" FAX-7, "Inspection"	FSU-3	FAX-7	WT-53	WT-52	WT-52	BR-6	ST-43	
Possible cause and SUSPECTED PARTS			Excessive joint angle	Joint sliding resistance	Imbalance	Improper installation, looseness	Parts interference	Wheel bearing damage	FRONT SUSPENSION	FRONT AXLE	TIRE	ROAD WHEEL	DRIVE SHAFT	BRAKE	STEERING	
Symptom	DRIVE SHAFT	Noise	x	x				x	x	x	x	x		x	x	
		Shake	x		x				x	x	x	x		x	x	
	FRONT AXLE	Noise				x	x	x	x		x	x	x	x	x	x
		Shake				x	x	x	x		x	x	x	x	x	x
		Vibration				x	x	x	x		x		x			x
		Shimmy				x	x		x		x	x		x	x	
		Shudder				x			x		x	x		x	x	
		Poor quality ride or handling				x	x		x		x	x				

x: Applicable

A
B
C
E
F
G
H
I
J
K
L
M
N
O
P

FAX

FRONT WHEEL HUB

< PERIODIC MAINTENANCE >

PERIODIC MAINTENANCE

FRONT WHEEL HUB

Inspection

INFOID:000000009135439

- Move the wheel hub and bearing assembly in an axial direction by hand to verify that looseness of wheel hub and bearing exists. If any looseness exists, replace the wheel hub and bearing assembly

Axial end play : Refer to [FAX-31, "Wheel Bearing"](#).

- Rotate wheel hub to verify if unusual noises or other irregular conditions exist. If any irregular conditions exist, replace the wheel hub and bearing assembly.

FRONT DRIVE SHAFT

< PERIODIC MAINTENANCE >

FRONT DRIVE SHAFT

Inspection

INFOID:000000009135440

- Check drive shaft mounting point and joint for looseness and other damage.
- Check boot for cracks and other damage.

CAUTION:

Replace entire drive shaft assembly when noise or vibration occurs from drive shaft.

A

B

C

FAX

E

F

G

H

I

J

K

L

M

N

O

P

FRONT WHEEL HUB

< REMOVAL AND INSTALLATION >

REMOVAL AND INSTALLATION

FRONT WHEEL HUB

Exploded View

INFOID:000000009135441

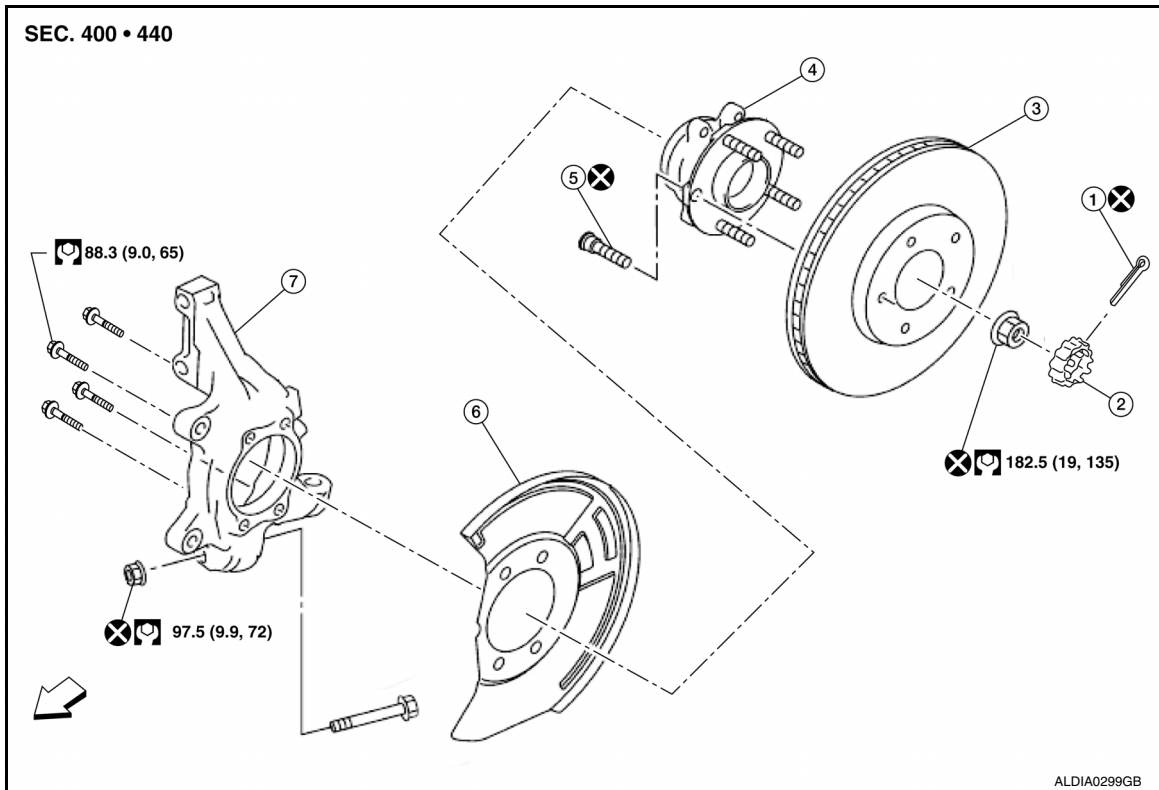

- | | | |
|-----------------------------------|-------------------|-----------------|
| 1. Cotter pin | 2. Retainer | 3. Rotor |
| 4. Wheel hub and bearing assembly | 5. Wheel hub bolt | 6. Splash guard |
| 7. Steering knuckle | ↔ Front | |

Removal and Installation

INFOID:000000009135442

REMOVAL

1. Remove front wheel and tire using power tool. Refer to [WT-53, "Adjustment"](#).
2. Remove brake caliper torque member bolts, leaving brake hose attached, reposition the caliper aside with wire. Refer to [BR-36, "BRAKE CALIPER ASSEMBLY : Removal and Installation"](#).

CAUTION:

Do not depress brake pedal while brake caliper is removed.

3. Put alignment marks on disc rotor and wheel hub and bearing assembly, then remove disc rotor.

CAUTION:

- Put alignment marks on the wheel hub and bearing assembly and the disc rotor before removing the disc rotor.
- Do not drop the disc rotor.

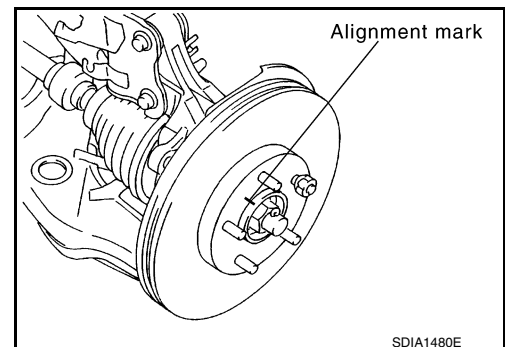

FRONT WHEEL HUB

< REMOVAL AND INSTALLATION >

- Remove wheel sensor bolt (A) and position wheel sensor aside. Refer to [BRC-125, "Exploded View - Front Wheel Sensor"](#).

CAUTION:

Do not pull on wheel sensor harness.

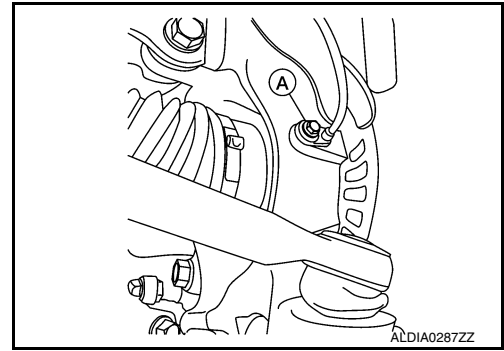

- Remove cotter pin.
- Remove nut retainer, then loosen lock nut from drive shaft using power tool.
- Using a piece of wood and a hammer, tap on the lock nut to disengage drive shaft from wheel hub.

CAUTION:

- Do not place drive shaft joint at an extreme angle. Be careful not to over extend slide joint.
- Do not allow drive shaft to hang without support.

NOTE:

Use suitable puller if drive shaft cannot be separated from wheel hub and bearing assembly.

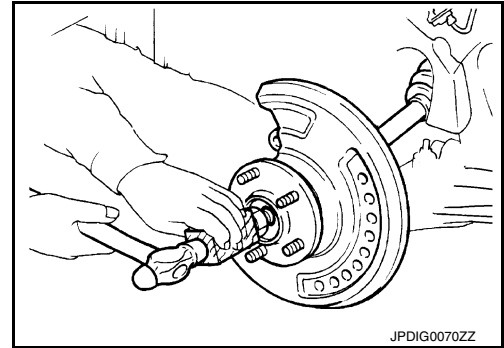

- Remove wheel hub lock nut.
- Remove wheel hub and bearing assembly bolts using power tool.
- Remove splash guard and wheel hub and bearing assembly from steering knuckle.

INSPECTION AFTER REMOVAL

Check components for deformation, cracks, and other damage. Replace if necessary.

Ball joint inspection

Check for boot breakage, axial looseness, and torque of transverse link ball joint and repair as necessary.

INSTALLATION

Installation is in the reverse order of the removal.

- Clean the mating surface of the wheel hub lock nut and wheel hub and bearing assembly.
- Clean the mating surface of the drive shaft and wheel hub and bearing assembly.

CAUTION:

- Do not use a power tool to tighten the wheel hub lock nut.
- Align the marks made on the rotor and front wheel hub during disassembly.
- Do not reuse cotter pin.
- Do not apply lubricating oil to the mating surfaces.

A

B

C

FAX

E

F

G

H

I

J

K

L

M

N

O

P

FRONT DRIVE SHAFT BOOT

< REMOVAL AND INSTALLATION >

FRONT DRIVE SHAFT BOOT

Exploded View

INFOID:000000009135443

LH

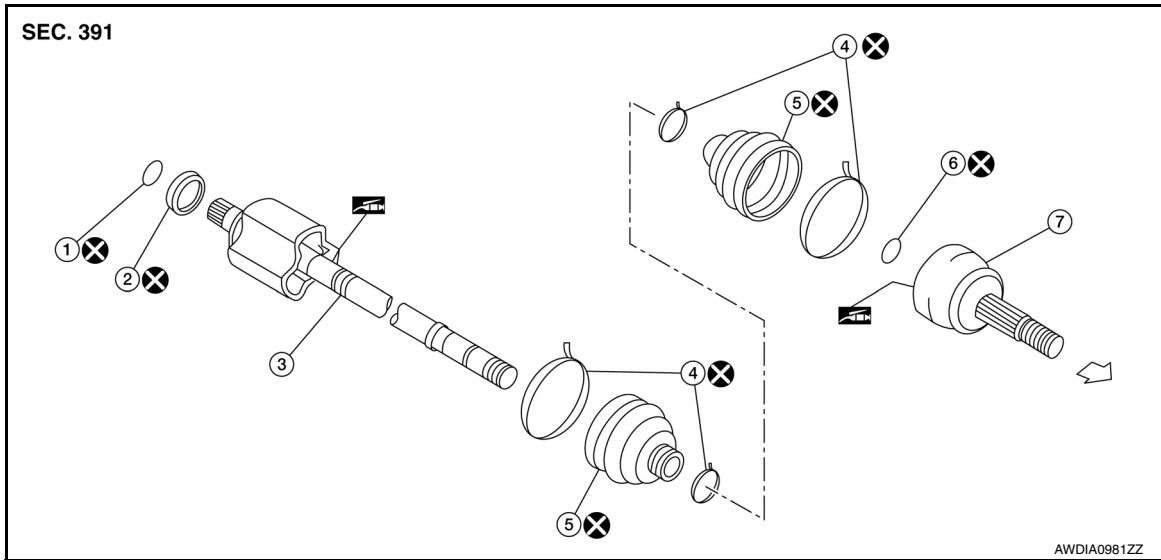

- | | | |
|-----------------------|----------------|---------------------|
| 1. Circular clip | 2. Dust shield | 3. Housing assembly |
| 4. Boot band | 5. Boot | 6. Circular clip |
| 7. Joint sub-assembly | ↔ Wheel side | |

 Fill NISSAN Genuine grease or equivalent.

RH

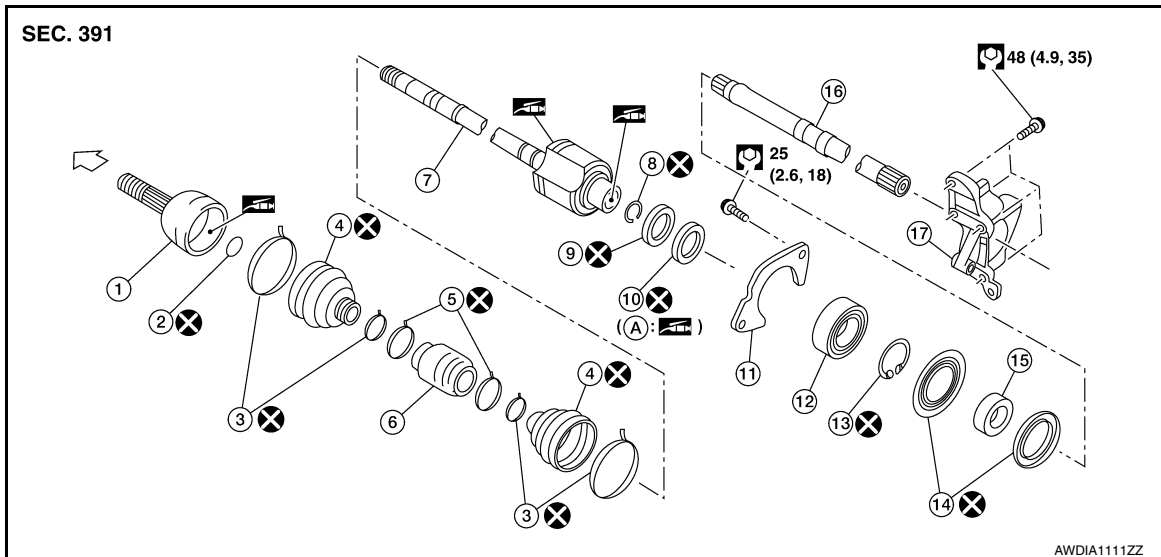

- | | | |
|-----------------------|------------------------------|---------------------------------|
| 1. Joint sub-assembly | 2. Circular clip | 3. Boot band |
| 4. Boot | 5. Damper band (if equipped) | 6. Dynamic damper (if equipped) |
| 7. Housing assembly | 8. Circular clip | 9. Dust shield |
| 10. Oil seal | 11. Bearing retainer | 12. Bearing |
| 13. Snap ring | 14. Dust shield | 15. Collar |
| 16. Link shaft | 17. Support bearing bracket | A: Oil seal lip |

FRONT DRIVE SHAFT BOOT

< REMOVAL AND INSTALLATION >

↩ Wheel side

 Fill NISSAN Genuine grease or equivalent.

WHEEL SIDE

WHEEL SIDE : Removal and Installation

INFOID:000000009135444

REMOVAL

1. Remove front wheel and tire using power tool. Refer to [WT-53. "Adjustment"](#).
2. Remove brake caliper torque member bolts, leaving brake hose attached, reposition the caliper aside with wire. Refer to [BR-36. "BRAKE CALIPER ASSEMBLY : Removal and Installation"](#).

CAUTION:

Do not depress brake pedal while brake caliper is removed.

3. Put alignment marks on disc rotor and wheel hub and bearing assembly, then remove disc rotor.

CAUTION:

- Put alignment marks on the wheel hub and bearing assembly and the disc rotor before removing the disc rotor.
- Do not drop the disc rotor.

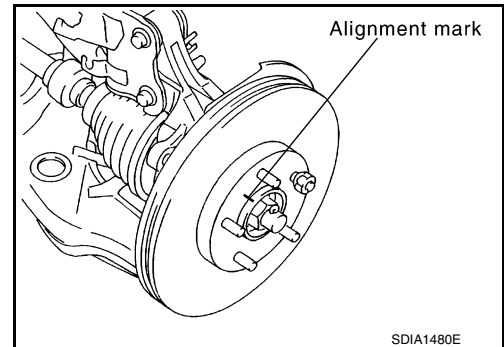

4. Remove wheel sensor bolt (A) and position wheel sensor aside. Refer to [BRC-125. "Exploded View - Front Wheel Sensor"](#).

CAUTION:

Do not pull on wheel sensor harness.

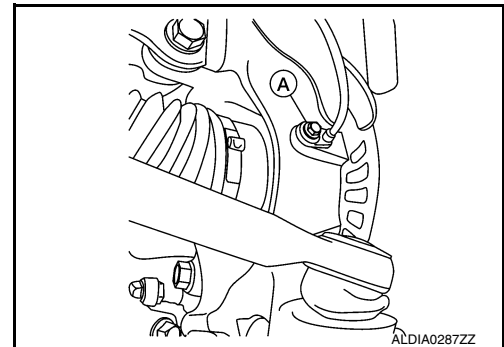

5. Remove cotter pin.
6. Remove nut retainer, then loosen lock nut from drive shaft using power tool.
7. Using a piece of wood and a hammer, tap on the lock nut to disengage drive shaft from wheel hub.

CAUTION:

- Do not place drive shaft joint at an extreme angle. Be careful not to over extend slide joint.
- Do not allow drive shaft to hang without support.

NOTE:

Use suitable puller if drive shaft cannot be separated from wheel hub and bearing assembly.

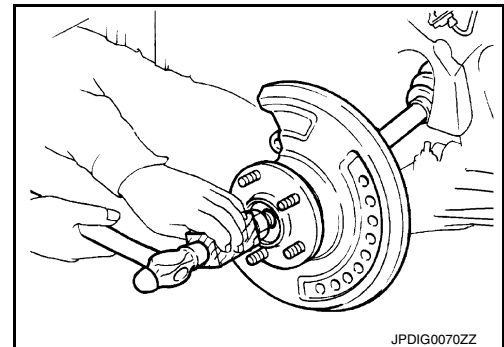

8. Remove wheel hub lock nut.
9. Remove strut assembly from steering knuckle. Refer to [FSU-14. "Exploded View"](#).
10. Remove drive shaft from front wheel hub.
11. Remove boot bands, and then remove boot from joint sub-assembly.

A
B
C
FAX
E
F
G
H
I
J
K
L
M
N
O
P

FRONT DRIVE SHAFT BOOT

< REMOVAL AND INSTALLATION >

12. Screw sliding hammer or suitable tool (A) 30 mm (1.18 in) or more into threaded part of joint sub-assembly. Support drive shaft with one hand and pull out joint sub-assembly with a sliding hammer or suitable tool from housing assembly.

CAUTION:

- Align sliding hammer or suitable tool and drive shaft and remove joint sub-assembly by pulling directly.
- If joint sub-assembly cannot be removed after five or more unsuccessful attempts, replace the entire drive shaft assembly.

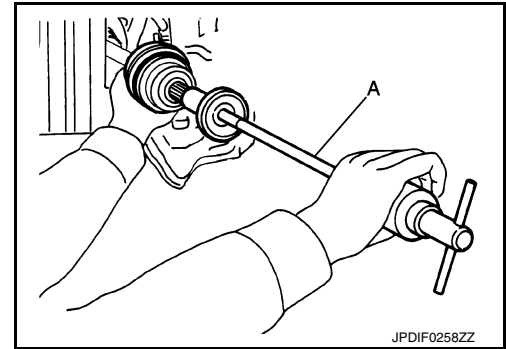

13. Remove circular clip (1) from housing assembly.
14. Remove boot from housing assembly.
15. Inspect the components. Refer to [FAX-7, "Inspection"](#).

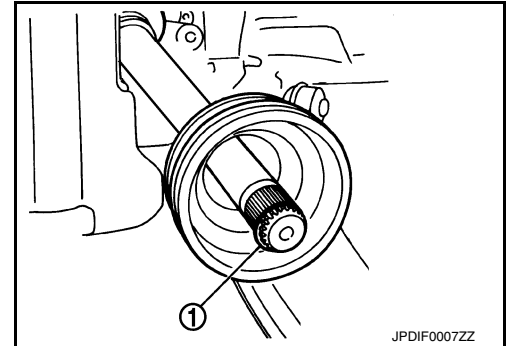

INSTALLATION

1. Clean the old grease on joint sub-assembly with paper shop cloth.
2. Fill serration slot joint sub-assembly with NISSAN genuine grease or equivalent.
CAUTION:
After applying grease, use a paper shop cloth to wipe off old grease that has oozed out.
3. Install boot and boot bands to housing assembly.
CAUTION:
 - Wrap serration on housing assembly with tape to protect the boot from damage.
 - Do not reuse boot and boot band.
4. Remove the tape wrapped around the serration on housing assembly.
5. Position the circular clip on groove at the housing assembly edge.
CAUTION:
Do not reuse circular clip.
6. Align both center axes of the housing assembly edge and joint sub-assembly. Then assemble housing assembly with joint sub-assembly holding circular clip.
7. Install joint sub-assembly (1) to housing assembly using suitable tool.
CAUTION:
Confirm that joint sub-assembly is correctly engaged while rotating drive housing assembly.
8. Apply the specified amount of grease into the large diameter side opening of the boot.

Grease amount : Refer to [FAX-31, "Drive Shaft"](#).

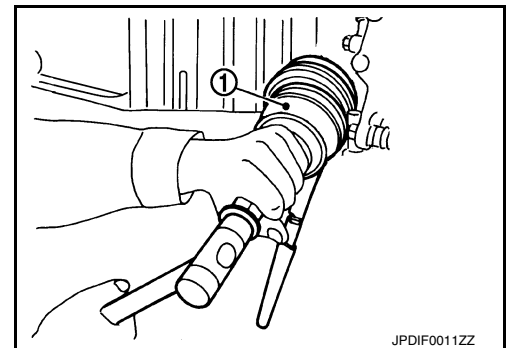

FRONT DRIVE SHAFT BOOT

< REMOVAL AND INSTALLATION >

9. Install the boot securely into grooves (indicated by "*" marks) shown in the figure.

CAUTION:

If grease adheres to the boot mounting surface (indicated by "*" mark) on the housing assembly or joint sub-assembly, boot may come off. Remove all grease from the boot mounting surface.

10. Make sure boot installation length (L) is the specified length. Insert a suitable tool into the large end of boot. Bleed air from boot to prevent boot deformation.

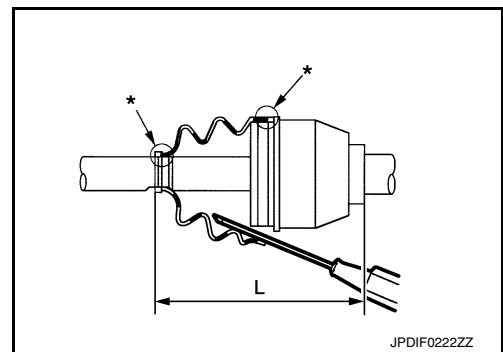

Boot installation length (L) : Refer to FAX-31, "Drive Shaft".

CAUTION:

- Boot may break if boot installation length is not within standard value.
- Be careful that suitable tool does not contact inside surface of boot.

11. Install new large and small boot bands securely using Tool.

Tool number : KV40107300 (—)

CAUTION:

Do not reuse boot band.

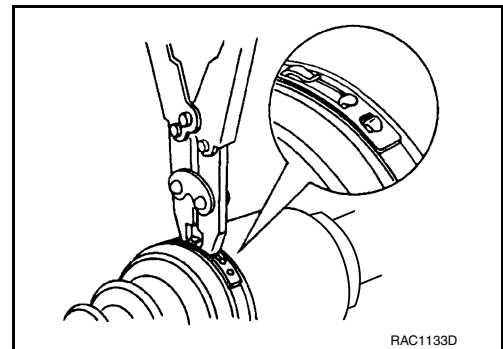

NOTE:

Secure boot band so that dimension (M) meets the specification as shown.

Dimension (M) : Refer to FAX-32, "Boot Bands".

12. Secure joint sub-assembly and housing assembly, and then make sure that they are in the correct position when rotating boot. Reinstall them using boot bands when boot installation positions become incorrect.

CAUTION:

Do not reuse boot band.

13. Clean the mating surface of wheel hub lock nut and front wheel hub.

CAUTION:

Do not apply lubricating oil to these mating surfaces.

14. Clean the mating surface of drive shaft (A) and front wheel hub.

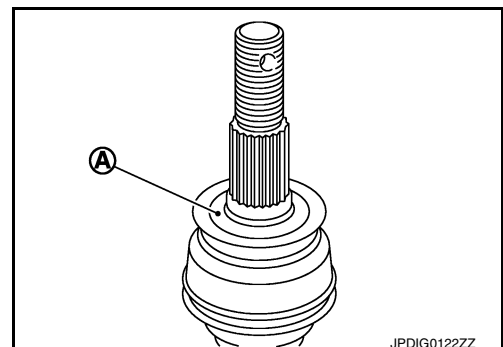
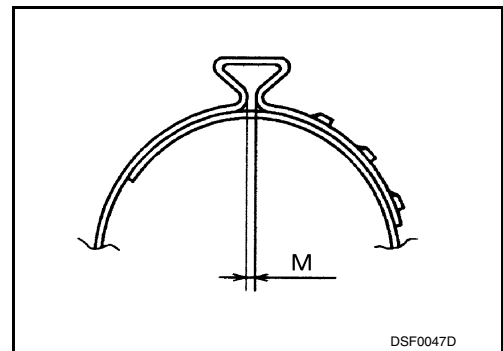

15. Insert drive shaft to wheel hub and bearing assembly, and then temporarily tighten front wheel hub lock nut.

FRONT DRIVE SHAFT BOOT

< REMOVAL AND INSTALLATION >

16. Install strut assembly to steering knuckle. Refer to [FSU-14. "Exploded View"](#).
17. Install disc rotor.
 - Align the index marks made on the rotor and front wheel hub during disassembly.
18. Install caliper assembly to steering knuckle. Refer to [BR-36. "BRAKE CALIPER ASSEMBLY : Removal and Installation"](#).
19. Install wheel sensor to steering knuckle. Refer to [BRC-125. "Exploded View - Front Wheel Sensor"](#).
20. Tighten the wheel hub lock nut to the specified torque. Refer to [FAX-8. "Exploded View"](#).

CAUTION:

- Do not use a power tool to tighten the wheel hub lock nut.
- Perform the final tightening of each of parts under unladen conditions, which were removed when removing wheel hub and bearing assembly and axle housing.

21. Install the nut retainer.
22. Install a new cotter pin. Refer to [FAX-8. "Exploded View"](#).
CAUTION:
 - Do not reuse cotter pin.
 - Bend cotter pin securely to prevent any looseness.
23. Install the front wheel and tire. Refer to [WT-53. "Adjustment"](#).

TRANSAXLE SIDE

TRANSAXLE SIDE : Removal and Installation

INFOID:000000009135445

NOTE:

Remove boot after removing drive shaft. Refer to [FAX-15. "Removal and Installation \(LH\)"](#), [FAX-17. "Removal and Installation \(RH\)"](#).

Inspection

INFOID:000000009135446

INSPECTION AFTER REMOVAL

- Move joint up/down, left/right, and in the axial directions. Check for motion that is not smooth and for significant looseness.
- Check boot for cracks, damage, and leakage of grease.
- Disassemble drive shaft and exchange malfunctioning part if there is a non-standard condition.

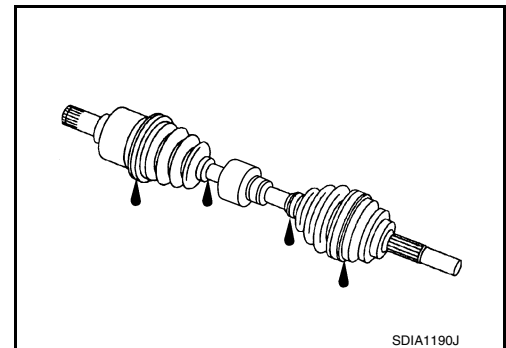

FRONT DRIVE SHAFT

< REMOVAL AND INSTALLATION >

FRONT DRIVE SHAFT

Exploded View (LH)

INFOID:000000009135447

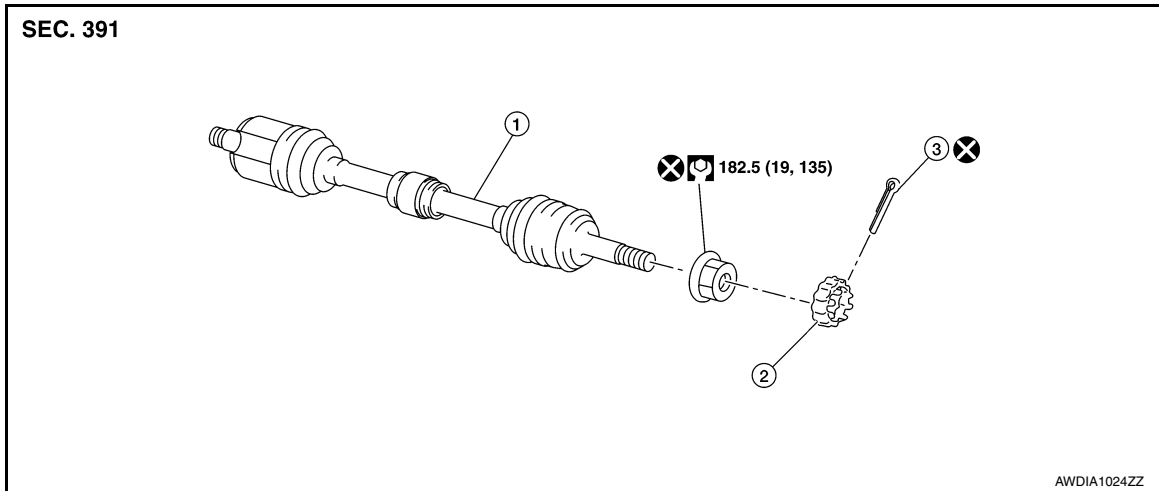

1. Drive shaft

2. Retainer

3. Cotter pin

Removal and Installation (LH)

INFOID:000000009135448

REMOVAL

1. Remove wheel and tire using power tool. Refer to [WT-53, "Adjustment"](#).
2. Remove brake caliper torque member bolts, leaving brake hose attached reposition the caliper aside with wire. Refer to [BR-36, "BRAKE CALIPER ASSEMBLY : Removal and Installation"](#).

CAUTION:

Do not depress brake pedal while brake caliper is removed.

3. Put alignment marks on disc rotor and wheel hub and bearing assembly, then remove disc rotor.

CAUTION:

- Put alignment marks on the wheel hub and bearing assembly and the disc rotor before removing the disc rotor.
- Do not drop the disc rotor.

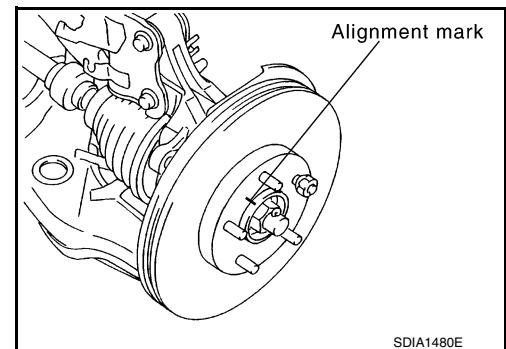

4. Remove wheel sensor bolt (A) and position wheel sensor aside. Refer to [BRC-125, "Exploded View - Front Wheel Sensor"](#).

CAUTION:

Do not pull on wheel sensor harness.

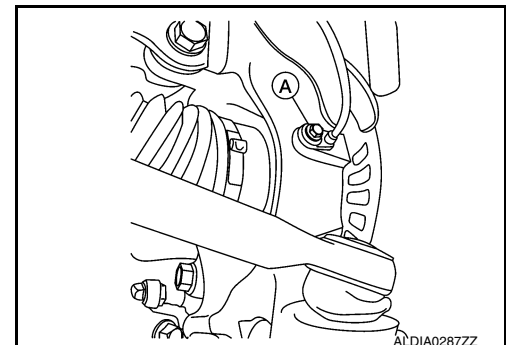

5. Remove cotter pin.

FRONT DRIVE SHAFT

< REMOVAL AND INSTALLATION >

6. Remove nut retainer, then loosen lock nut from drive shaft using power tool.
7. Using a piece of wood and a hammer, tap on the lock nut to disengage drive shaft from wheel hub.

CAUTION:

- Do not place drive shaft joint at an extreme angle. Be careful not to over extend slide joint.
- Do not allow drive shaft to hang without support.

NOTE:

Use suitable puller if drive shaft cannot be separated from wheel hub and bearing assembly.

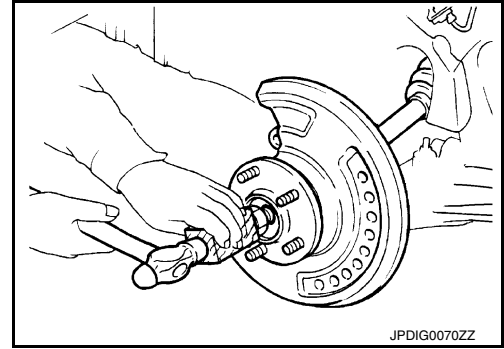

8. Remove wheel hub lock nut.
9. Remove front strut to steering knuckle bolts and nuts, then separate steering knuckle from strut. Refer to [FSU-14, "Exploded View"](#).
10. Remove the LH drive shaft from transaxle assembly.
 - Remove drive shaft from transaxle using Tool and drive shaft puller or suitable tool.
 - Set Tool (A) and a drive shaft puller or suitable tool (B) between drive shaft (slide joint side) and transaxle as shown, then remove drive shaft.

Tool number : KV40107500 (—)

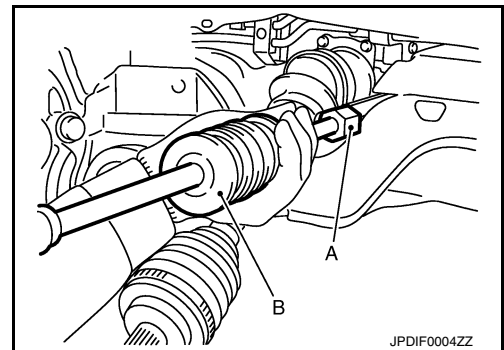

INSPECTION AFTER REMOVAL

- Move joint up/down, left/right, and in axial direction. Check for any rough movement or significant looseness.
- Check boot for cracks or other damage, and for grease leakage.
- If damaged, disassemble drive shaft to verify damage, and repair or replace as necessary.

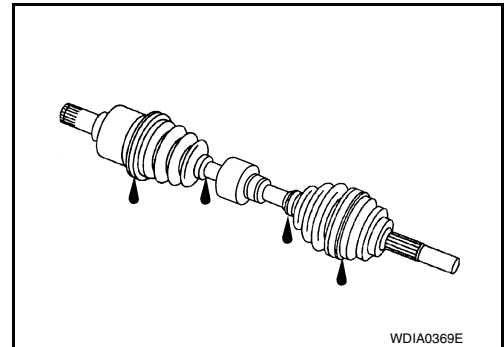

INSTALLATION

Installation is in the reverse order of removal.

CAUTION:

Do not reuse non-reusable parts.

- Tighten the drive shaft lock nut to specification. Refer to [FAX-15, "Exploded View \(LH\)"](#).
- In order to prevent damage to differential side oil seal, place Tool (A) onto oil seal before inserting drive shaft as shown. Slide drive shaft into slide joint and tap with a hammer to install securely.

Tool number : KV38107900 (—)

- Install new circlip on drive shaft in the circular clip groove on transaxle side. Refer to [FAX-20, "Disassembly and Assembly \(LH\)"](#).

CAUTION:

Make sure the new circlip on the drive shaft is securely fastened.

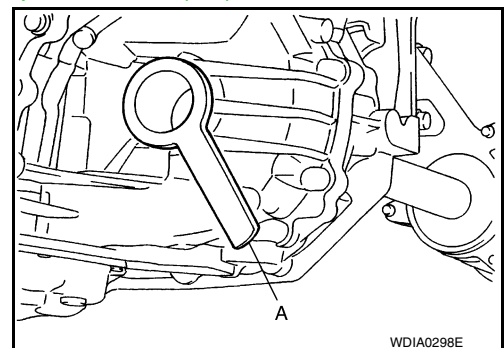

FRONT DRIVE SHAFT

< REMOVAL AND INSTALLATION >

- After its insertion, try to pull the flange out of the slide joint by hand. If it pulls out, the circlip is not properly meshed with the transaxle side gear.
- Tighten wheel nuts to specification. Refer to [WT-53. "Adjustment"](#).

Exploded View (RH)

INFOID:000000009135449

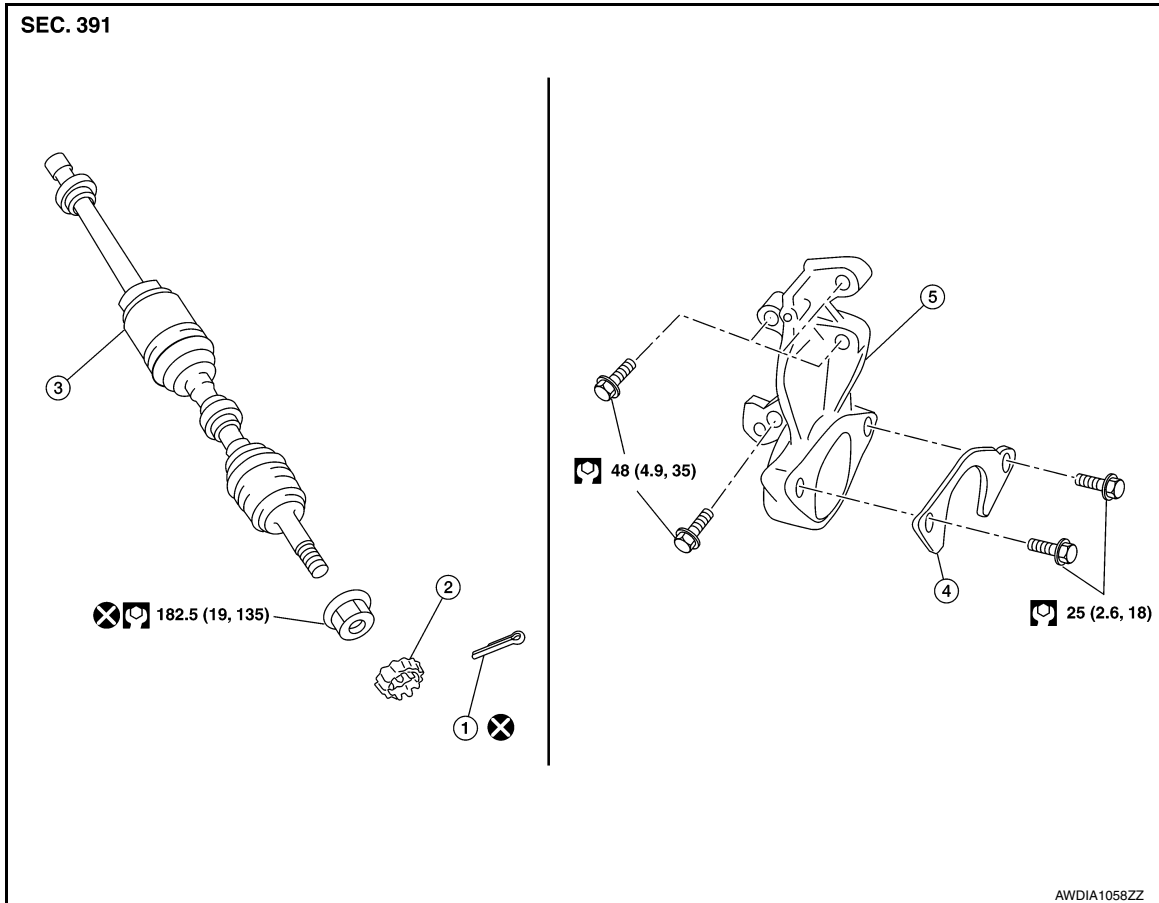

- | | | |
|---------------------|----------------------------|----------------|
| 1. Cotter pin | 2. Retainer | 3. Drive shaft |
| 4. Bearing retainer | 5. Support bearing bracket | |

Removal and Installation (RH)

INFOID:000000009135450

REMOVAL

1. Remove wheel and tire using power tool. Refer to [WT-53. "Adjustment"](#).
2. Remove brake caliper torque member bolts, leaving brake hose attached, reposition the caliper aside with wire. Refer to [BR-36. "BRAKE CALIPER ASSEMBLY : Removal and Installation"](#).

CAUTION:

Do not depress brake pedal while brake caliper is removed.

FRONT DRIVE SHAFT

< REMOVAL AND INSTALLATION >

- Put alignment marks on disc rotor and wheel hub and bearing assembly, then remove disc rotor.

CAUTION:

- Put alignment marks on the wheel hub and bearing assembly and the disc rotor before removing the disc rotor.
- Do not drop the disc rotor.

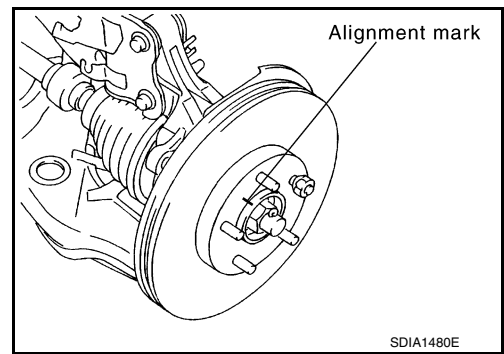

- Remove wheel sensor bolt (A) and position wheel sensor aside. Refer to [BRC-125, "Exploded View - Front Wheel Sensor"](#).

CAUTION:

- Do not pull on wheel sensor harness.

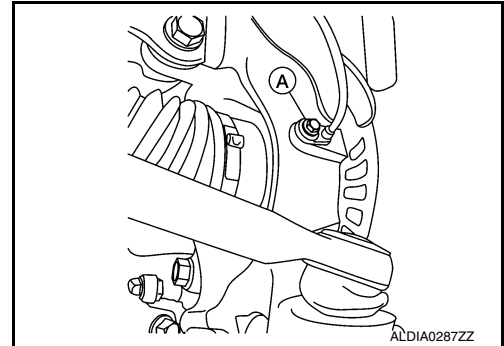

- Remove cotter pin.
- Remove nut retainer, then loosen lock nut from drive shaft using power tool.
- Using a piece of wood and a hammer, tap on the lock nut to disengage drive shaft from wheel hub.

CAUTION:

- Do not place drive shaft joint at an extreme angle. Be careful not to over extend slide joint.
- Do not allow drive shaft to hang without support.

NOTE:

Use suitable puller if drive shaft cannot be separated from wheel hub and bearing assembly.

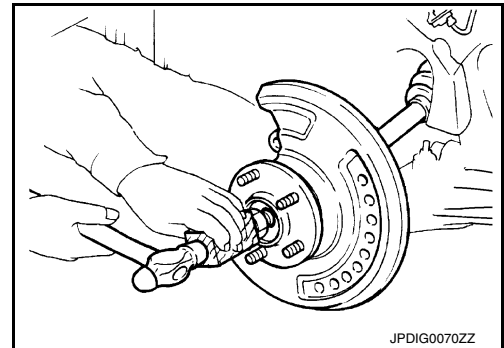

- Remove wheel hub lock nut.
- Remove front strut to steering knuckle bolts and nuts, then separate steering knuckle from strut. Refer to [FSU-14, "Exploded View"](#).
- Remove bearing retainer to support bearing bracket bolts.
- Remove RH drive shaft from transaxle assembly.
 - Use Tool (A) and suitable tool (B) while inserting tip of tool between housing and transaxle assembly.

CAUTION:

Do not place drive shaft joint at an extreme angle when removing drive shaft. Also be careful not to overextend slide joint.

Tool number (A) : KV40107500 (—)

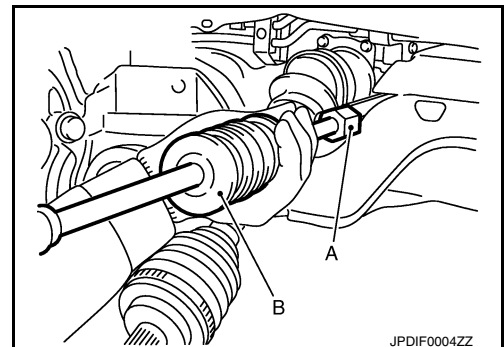

INSPECTION AFTER REMOVAL

- Move joint up/down, left/right, and in axial direction. Check for any rough movement or significant looseness.

FRONT DRIVE SHAFT

< REMOVAL AND INSTALLATION >

- Check boot for cracks or other damage, and for grease leakage.
- If damaged, disassemble drive shaft to verify damage, and repair or replace as necessary.

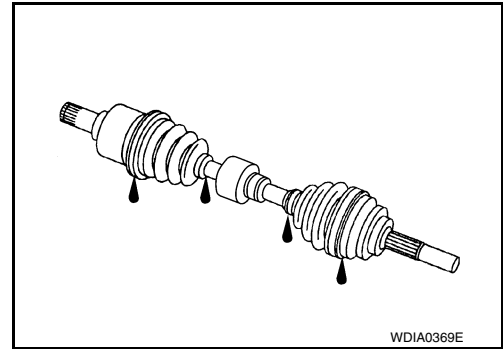

INSTALLATION

Installation is in the reverse order of removal.

CAUTION:

Do not reuse non-reusable parts.

- Tighten retaining bracket bolts and support bearing bracket bolts to specifications. Refer to [FAX-17, "Exploded View \(RH\)"](#).
- In order to prevent damage to differential side oil seal, place Tool (A) onto oil seal before inserting drive shaft as shown. Slide drive shaft into slide joint and tap with a hammer to install securely.

Tool number : KV38107900 (—)

- Install new circlip on drive shaft in the circular clip groove on transaxle side. Refer to [FAX-25, "Disassembly and Assembly \(RH\)"](#).

CAUTION:

Make sure the new circlip on the drive shaft is securely fastened.

- After its insertion, try to pull the flange out of the slide joint by hand. If it pulls out, the circlip is not properly meshed with the transaxle side gear.
- Tighten the wheel nuts to specification. Refer to [WT-53, "Adjustment"](#).

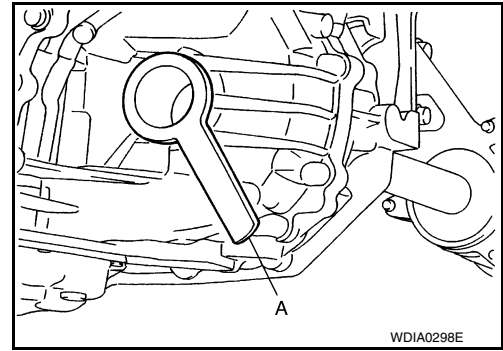

A
B
C
FAX
E
F
G
H
I
J
K
L
M
N
O
P

FRONT DRIVE SHAFT

< UNIT DISASSEMBLY AND ASSEMBLY >

UNIT DISASSEMBLY AND ASSEMBLY

FRONT DRIVE SHAFT

Disassembly and Assembly (LH)

INFOID:000000009135451

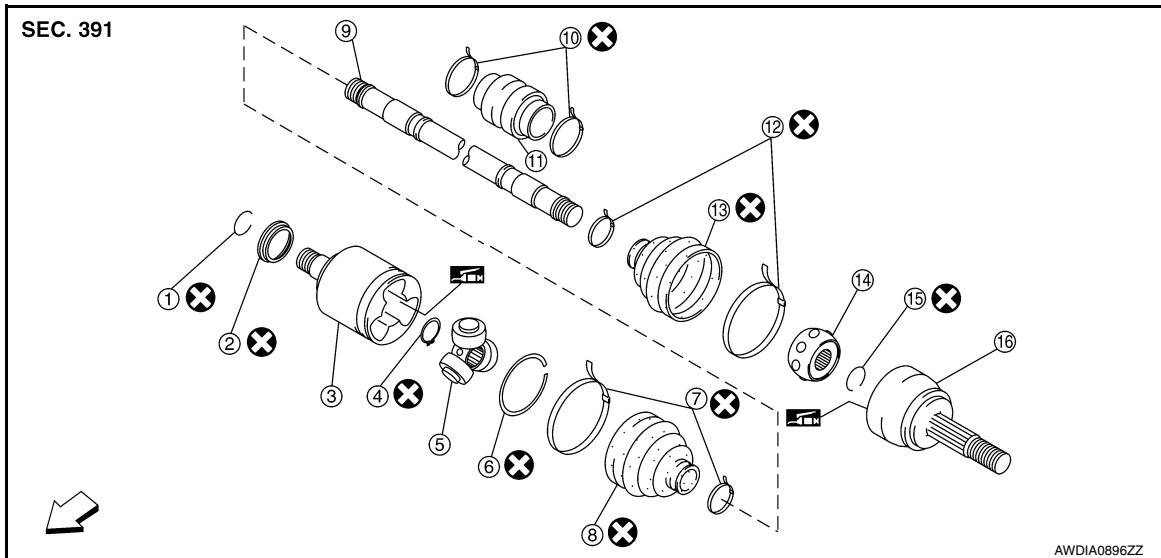

- | | | |
|------------------------|--|------------------------|
| 1. Circlip | 2. Dust shield | 3. Slide joint housing |
| 4. Snap ring | 5. Spider assembly | 6. Stopper ring |
| 7. Boot band | 8. Boot | 9. Shaft |
| 10. Damper band | 11. Damper | 12. Boot band |
| 13. Boot | 14. Ball cage / Steel ball / Inner race assembly | 15. Circlip |
| 16. Joint sub-assembly | ⇐ Front | |

DISASSEMBLY

Transaxle Side

1. Mount front drive shaft in a vise.

CAUTION:

When mounting shaft in a vise, always use copper or aluminum plates between vise and shaft.

2. Remove boot bands and slide the boot back.
3. Remove circlip and dust shield from slide joint housing.
4. Put matching marks on slide joint housing and shaft before separating joint assembly.
5. Remove stopper ring with a suitable tool, then pull out slide joint housing.

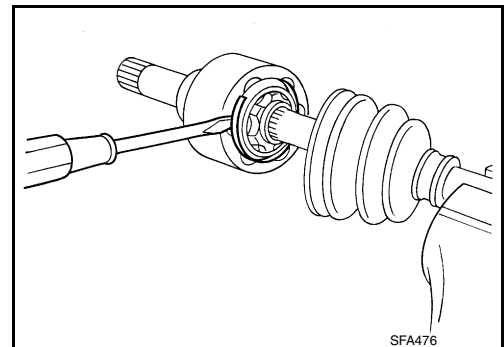

FRONT DRIVE SHAFT

< UNIT DISASSEMBLY AND ASSEMBLY >

- Put matching marks on spider assembly and shaft.

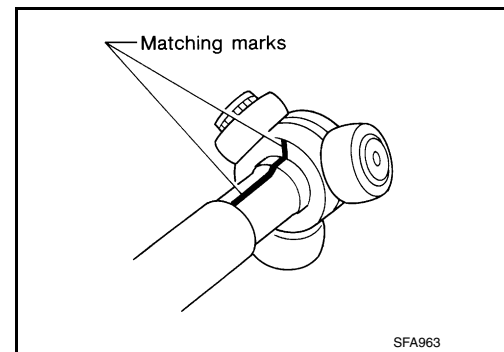

- Remove snap ring using a suitable tool, then remove spider assembly from shaft.
- Remove boot from shaft.
- Clean the old grease off of the slide joint assembly.

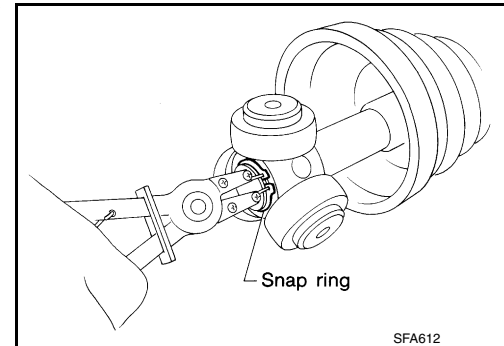

Wheel Side

- Mount the front drive shaft in a vise.

CAUTION:

When mounting shaft in a vise, always use copper or aluminum plates between vise and shaft.

- Remove boot bands and slide the boot back.
- Screw a sliding hammer or suitable tool 30 mm (1.18 in) or more into threaded part of joint sub-assembly. Pull joint sub-assembly out of shaft.

CAUTION:

- Align sliding hammer or suitable tool and drive shaft then remove joint sub-assembly by pulling directly.
- If joint sub-assembly cannot be removed after five or more unsuccessful attempts, replace the entire drive shaft assembly.

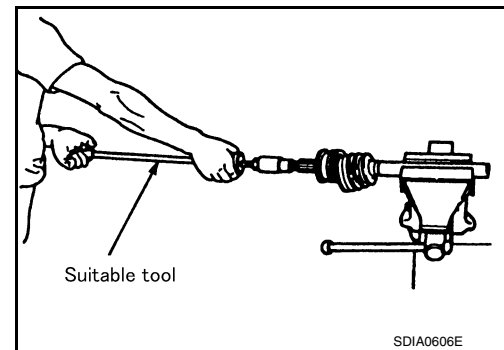

- Remove boot from shaft.
- Remove circlip from shaft.
- While rotating ball cage, clean the old grease off of the joint sub-assembly.

Damper

- Remove damper bands, then remove damper from shaft.

INSPECTION AFTER DISASSEMBLY

Shaft

- Replace shaft if there is bending, cracking, or other damage.

Joint Sub-Assembly

- Make sure there is no rough rotation or unusual axial looseness.
- Make sure there is no foreign material inside joint sub-assembly.
- Check joint sub-assembly for compression scars, cracks or fractures.

CAUTION:

If there are any irregular conditions of joint sub-assembly components, replace the entire joint sub-assembly.

FRONT DRIVE SHAFT

< UNIT DISASSEMBLY AND ASSEMBLY >

Slide Joint Housing

- Make sure there are no compression scars, cracks or fractures or unusual wear of ball rolling surface.
- Make sure there is no damage to shaft screws.
- Make sure there is no deformation of boot installation parts.

Ball Cage

- Make sure there are no compression scars, cracks, fractures of sliding surface.

Steel Ball

- Make sure there are no compression scars, cracks, fractures or unusual wear.

Inner Race

- Check ball sliding surface for compression scars, cracks or fractures.
- Make sure there is no damage to serrated part.

CAUTION:

If there are any irregular conditions in the component, replace with a new set of joint sub-assembly, ball cage, steel ball and inner race.

Damper

- Check damper for cracks or wear. Install damper with new damper bands.

ASSEMBLY

Transaxle Side

1. Install new boot and new small boot band on shaft.
CAUTION:
 - **Cover drive shaft serration with tape to prevent damage to boot during installation.**
2. Remove protective tape wound around serrated part of shaft.

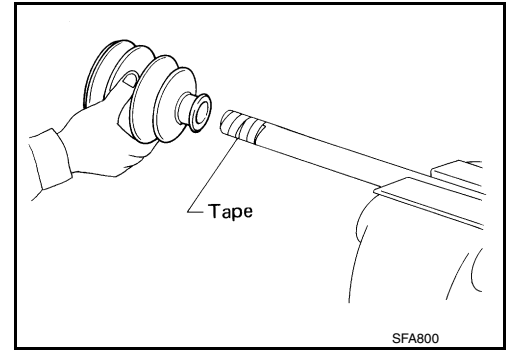

3. Install spider assembly securely, making sure the matching marks which were made during disassembly are properly aligned.
4. Install new snap ring using a suitable tool.
5. Pack drive shaft with specified amount of new grease (Genuine NISSAN Grease or equivalent).

Grease quantity : Refer to [FAX-31, "Drive Shaft"](#).

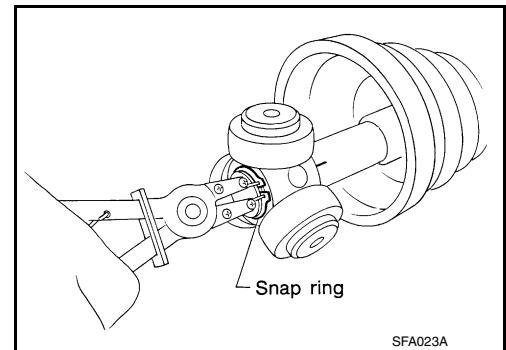

6. Install new stopper ring to housing of slide joint assembly.
7. After installation, pull shaft to check engagement between slide joint assembly and stopper ring.

FRONT DRIVE SHAFT

< UNIT DISASSEMBLY AND ASSEMBLY >

8. Install boot securely into grooves (indicated by * marks) as shown.

CAUTION:

If there is grease on boot mounting surfaces (indicated by * marks) of shaft and housing, boot may come off. Clean all grease from surfaces.

9. Make sure boot installation length (L) is the length specified below. Insert a suitable tool into the large end of boot. Bleed air from boot to prevent boot deformation.

Boot installation length (L)

: Refer to [FAX-31, "Drive Shaft"](#).

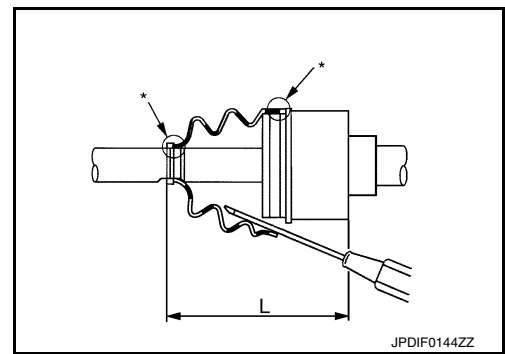

CAUTION:

- Boot may break if boot installation length is less than standard value.
- Be careful that suitable tool does not contact inside surface of boot.

10. Secure large and small ends of boot with new boot bands as shown.

CAUTION:

Discard old boot bands and replace with new ones.

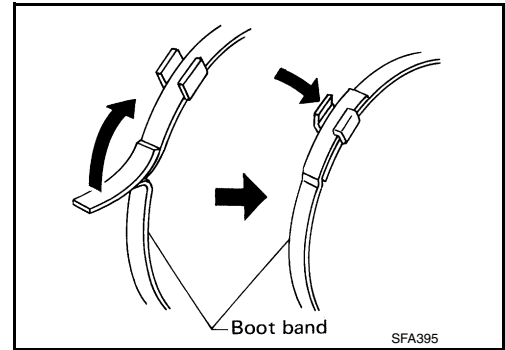

11. Install new dust shield to slide joint housing.

12. After installing housing and shaft, make sure boot position is correct. If boot position is not correct, remove old boot bands then reposition the boot and secure with new boot bands.

Wheel Side

1. Insert the amount of grease (Genuine NISSAN Grease or equivalent) into joint sub-assembly serration hole until grease begins to ooze from ball groove and serration hole. After inserting grease, use a shop cloth to wipe off old grease that has oozed out.

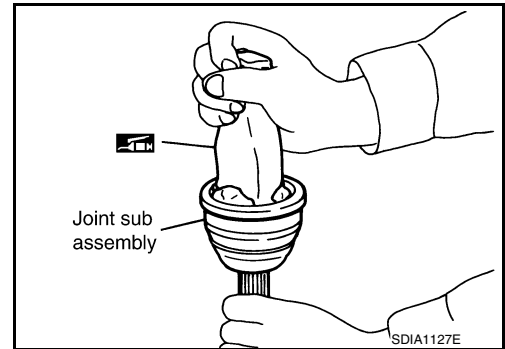

2. Cover serrated part of shaft with tape. Install new boot band and boot to shaft. Be careful not to damage boot.

CAUTION:

Discard old boot band and boot; replace with new one.

3. Remove protective tape wound around serrated part of shaft.

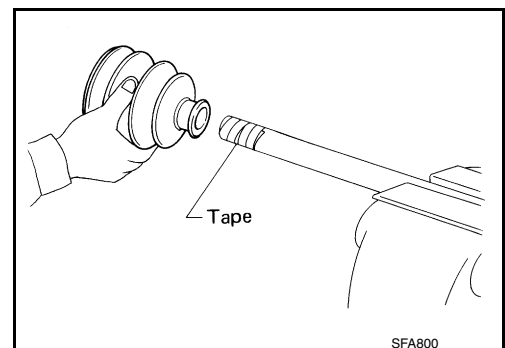

A
B
C
FAX
E
F
G
H
I
J
K
L
M
N
O
P

FRONT DRIVE SHAFT

< UNIT DISASSEMBLY AND ASSEMBLY >

- Attach new circlip to shaft. The circlip must fit securely into shaft groove. Attach nut to joint sub-assembly. Use a suitable tool to press-fit.

CAUTION:

Discard old circlip and replace with new one.

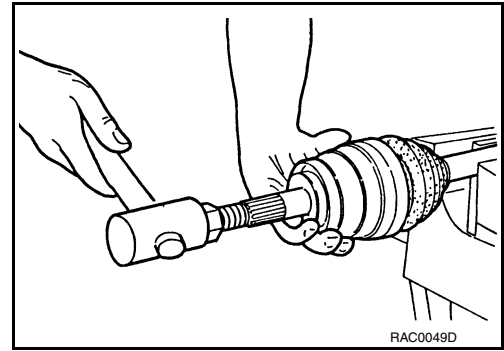

- Insert the amount of new grease (Genuine NISSAN Grease or equivalent) listed below into housing from large end of boot.

Grease quantity : Refer to [FAX-31, "Drive Shaft"](#).

- Install boot securely into grooves (indicated by * marks) as shown.

CAUTION:

If there is grease on boot mounting surfaces (indicated by * marks) of shaft and housing, boot may come off. Remove all grease from surfaces.

- Make sure boot installation length (L) is the specified length indicated below. Insert a suitable tool into the large end of boot. Bleed air from boot to prevent boot deformation.

Boot installation length (L) : Refer to [FAX-31, "Drive Shaft"](#).

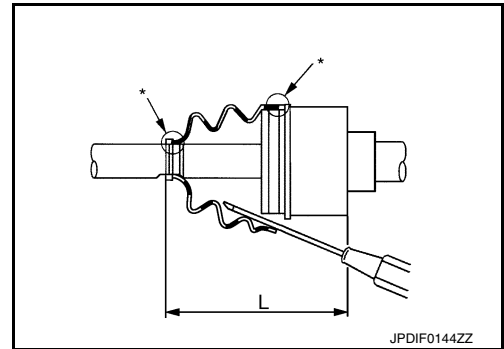

CAUTION:

- Boot may break if boot installation length is less than standard value.
- Be careful that suitable tool does not contact inside surface of boot.

- Install new large and small boot bands securely using Tool.

Tool number : KV40107300 (—)

NOTE:

Do not reuse boot bands.

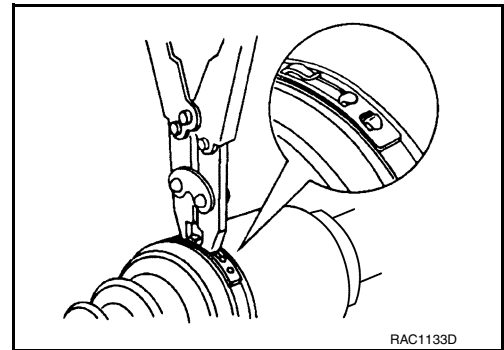

CAUTION:

Secure boot band so that dimension (M) meets specification as shown.

Dimension (M) : Refer to [FAX-32, "Boot Bands"](#).

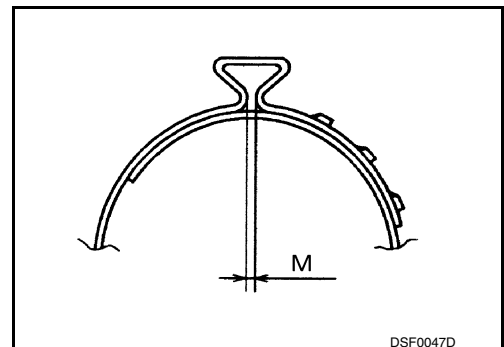

FRONT DRIVE SHAFT

< UNIT DISASSEMBLY AND ASSEMBLY >

- After installing housing and shaft, rotate boot to check whether or not the actual position is correct. If boot position is not correct, remove old boot bands, then reposition the boot and secure with new boot bands.

Damper

- Use new damper bands for installation.
- Install damper from stationary-joint side while holding it securely.

Dimension (A) : Refer to [FAX-31, "Dynamic Damper"](#).

Dimension (B) : Refer to [FAX-31, "Dynamic Damper"](#).

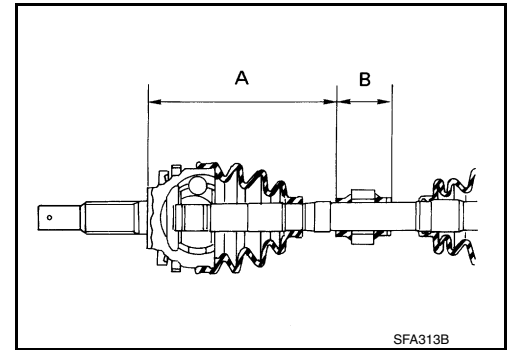

Disassembly and Assembly (RH)

INFOID:000000009135452

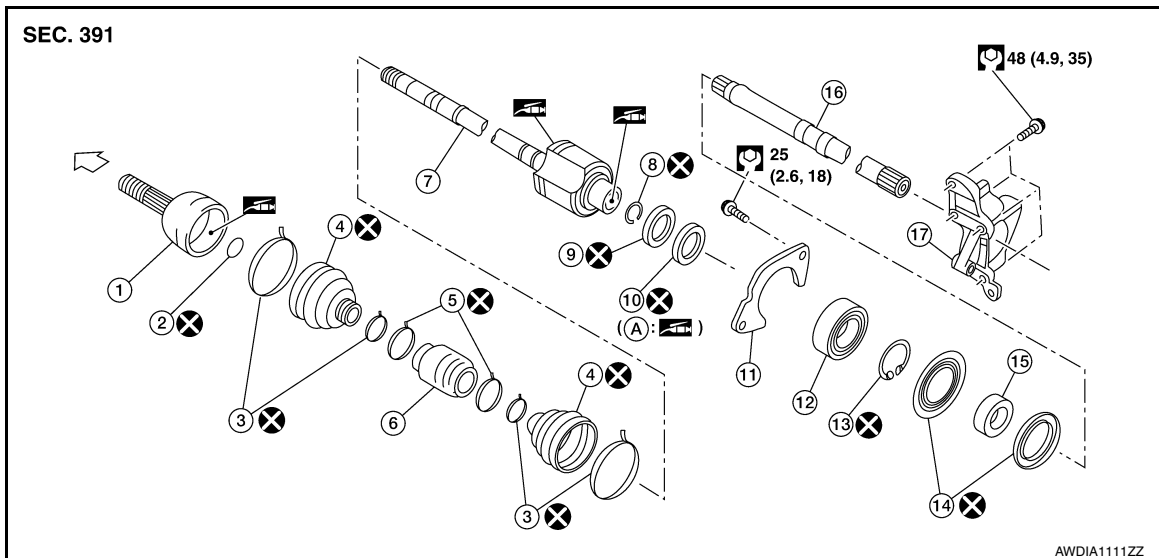

- | | | |
|-----------------------|------------------------------|---------------------------------|
| 1. Joint sub-assembly | 2. Circular clip | 3. Boot band |
| 4. Boot | 5. Damper band (if equipped) | 6. Dynamic damper (if equipped) |
| 7. Housing assembly | 8. Circular clip | 9. Dust shield |
| 10. Oil seal | 11. Bearing retainer | 12. Bearing |
| 13. Snap ring | 14. Dust shield | 15. Collar |
| 16. Link shaft | 17. Support bearing bracket | A: Oil seal lip |

← Wheel side

Fill NISSAN Genuine grease or equivalent.

DISASSEMBLY

Transaxle Side

- Press shaft in a vise.

CAUTION:
When retaining shaft in a vise, always use copper or aluminum plates between vise and shaft.
- Remove circlip and dust shield from slide joint housing.
- Remove boot bands and slide the boots back.
- Put matching marks on slide joint housing and shaft before separating slide joint housing.

FRONT DRIVE SHAFT

< UNIT DISASSEMBLY AND ASSEMBLY >

5. Remove stopper ring using a suitable tool, then pull out slide joint housing.

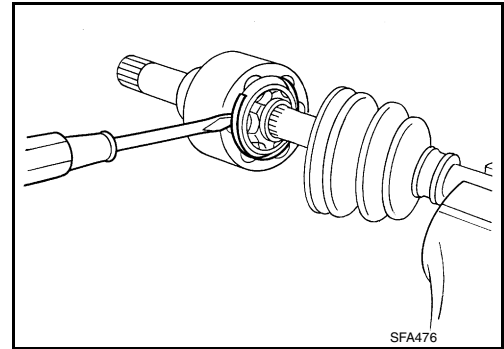

6. Put matching marks on spider assembly and shaft.

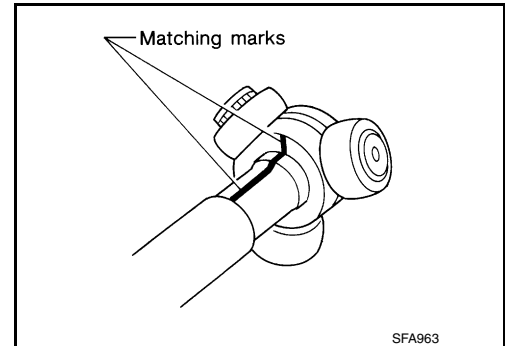

7. Remove snap ring using a suitable tool, then remove spider assembly from shaft.
8. Remove boot from shaft.
9. Clean old grease off of the slide joint housing.

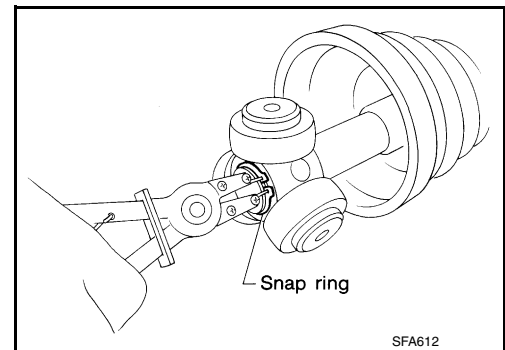

Wheel Side

1. Mount the front drive shaft in a vise.

CAUTION:

When mounting shaft in a vise, always use copper or aluminum plates between vise and shaft.

2. Remove boot bands and slide the boot back.
3. Screw a sliding hammer or suitable tool 30 mm (1.18 in) or more into threaded part of joint sub-assembly. Pull joint sub-assembly out of shaft.

CAUTION:

- Align sliding hammer or suitable tool and drive shaft then remove joint sub-assembly by pulling directly.
- If joint sub-assembly cannot be removed after five or more unsuccessful attempts, replace the entire drive shaft assembly.

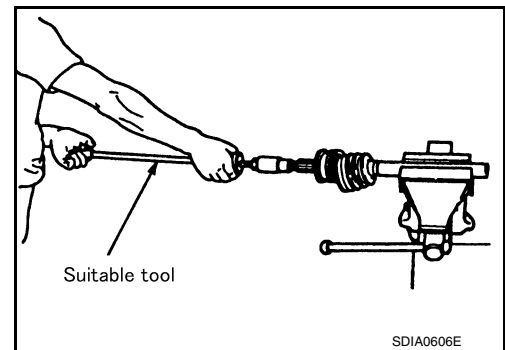

4. Remove boot from shaft.
5. Remove circlip from shaft.
6. While rotating ball cage, clean the old grease off of the joint sub-assembly.

Support Bearing

1. Remove dust shield from slide joint assembly using a suitable tool.

FRONT DRIVE SHAFT

< UNIT DISASSEMBLY AND ASSEMBLY >

2. Remove snap ring (A) using a suitable tool.
3. Press support bearing assembly off slide joint assembly using a suitable tool.

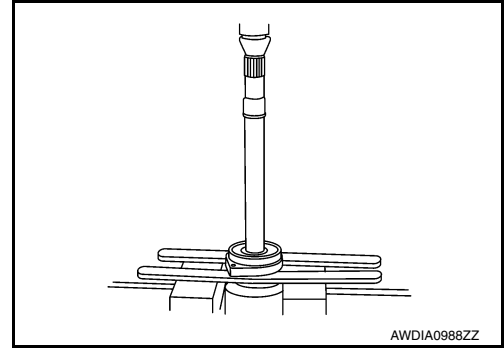

A

B

C

FAX

Damper (if equipped)

- Remove damper bands, then remove damper from shaft.

INSPECTION AFTER DISASSEMBLY

Shaft

- Replace shaft if there is any bending, cracking, or other damage.

Joint Sub-assembly

- Make sure there is no rough rotation or unusual axial looseness.
- Make sure there is no foreign material inside joint sub-assembly.
- Check joint sub-assembly for compression scars, cracks or fractures.

CAUTION:

If there are any irregular conditions of joint sub-assembly components, replace the entire joint sub-assembly.

Sliding Joint Housing and Spider Assembly

- If roller surface of spider assembly has scratches or wear, replace housing and spider assembly.

NOTE:

Housing and spider assembly are components which are used as a set.

Support Bearing

- Make sure wheel bearing rolls freely and is free from noise, cracks, pitting or wear.

Damper (if equipped)

- Check damper for cracks or wear. Install damper with new damper bands.

ASSEMBLY

Transaxle Side

1. Cover serrated part of shaft with tape. Install new boot and boot band onto shaft. Be careful not to damage boot.

CAUTION:

- **Discard old boot and boot band; replace with new ones.**

2. Remove protective tape wound around serrated part of shaft.

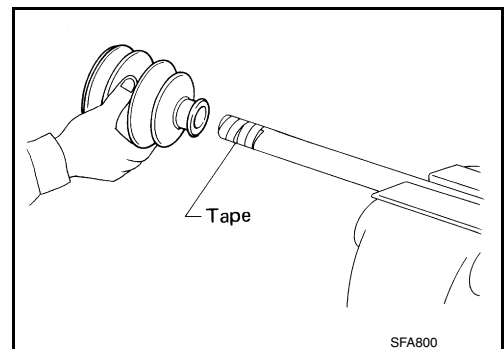

E

F

G

H

I

J

K

L

M

N

O

P

FRONT DRIVE SHAFT

< UNIT DISASSEMBLY AND ASSEMBLY >

4. Install new snap ring using a suitable tool.
5. Pack drive shaft with specified amount of grease (Genuine NISSAN Grease or equivalent).

Grease quantity : Refer to [FAX-31, "Drive Shaft"](#).

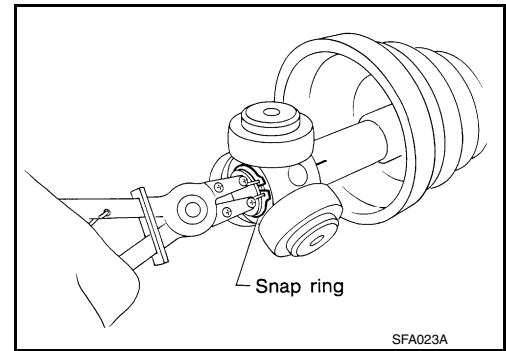

6. Install new stopper ring to slide joint assembly.
7. After installation, pull shaft to check engagement between slide joint assembly and stopper ring.
8. Install boot securely into grooves (indicated by * marks) as shown.

CAUTION:

If there is grease on boot mounting surfaces (indicated by * marks) of shaft and housing, boot may come off. Remove all grease from surfaces.

9. Make sure boot installation length (L) is the length indicated below. Insert a suitable tool into the large end of boot. Bleed air from boot to prevent boot deformation.

Boot installation length (L) : Refer to [FAX-31, "Drive Shaft"](#).

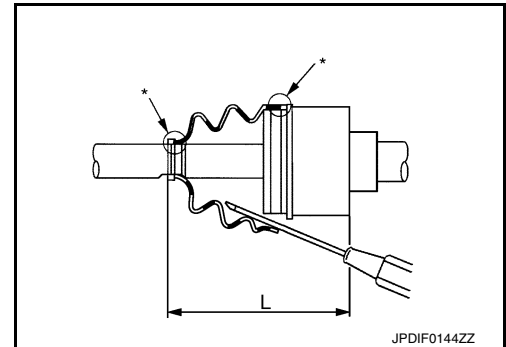

CAUTION:

- Boot may break if boot installation length is less than standard value.
- Be careful that suitable tool does not contact inside surface of boot.

10. Secure big and small ends of boot with new boot bands as shown.

CAUTION:

Discard old boot bands; replace with new ones.

11. Install new dust shield to slide joint housing.
12. After installing housing and shaft, rotate boot to check whether or not the actual position is correct. If boot position is not correct, remove old boot bands then reposition the boot and secure with new boot bands.

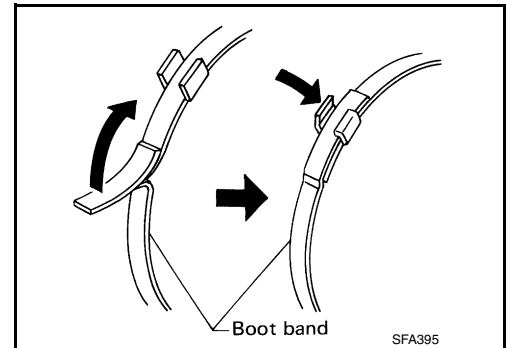

Wheel Side

1. Insert the amount of grease (Genuine NISSAN Grease or equivalent) into joint sub-assembly serration hole until grease begins to ooze from ball groove and serration hole. After inserting grease, use a shop cloth to wipe off old grease that has oozed out.

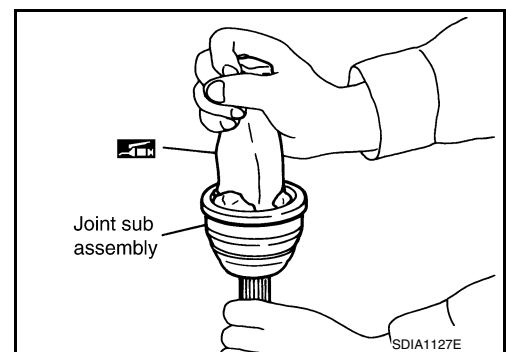

FRONT DRIVE SHAFT

< UNIT DISASSEMBLY AND ASSEMBLY >

2. Cover serrated part of shaft with tape. Install new boot and boot band onto shaft. Be careful not to damage boot.

CAUTION:

Discard old boot and boot band; replace with new ones.

3. Remove protective tape wound around serrated part of shaft.

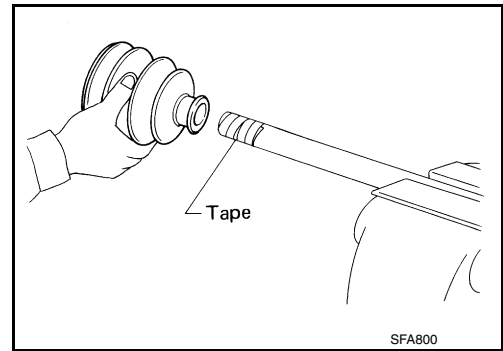

4. Attach new circlip to shaft. The circlip must fit securely into shaft groove. Attach nut to joint sub-assembly. Use a suitable tool to press-fit.

CAUTION:

Discard old circlip; replace with new ones.

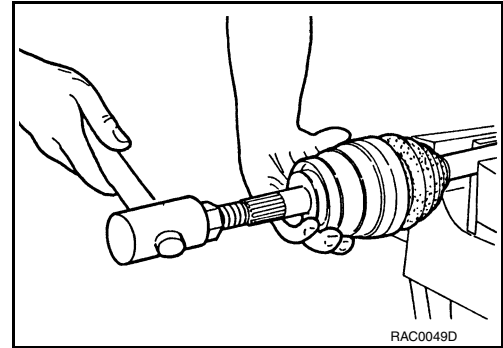

5. Insert the amount of new grease (Genuine NISSAN Grease or equivalent) listed below into housing from large end of boot.

Grease quantity : Refer to [FAX-31, "Drive Shaft"](#).

6. Install boot securely into grooves (indicated by * marks) as shown.

CAUTION:

If there is grease on boot mounting surfaces (indicated by * marks) of shaft and housing, boot may come off. Remove all grease from surfaces.

7. Make sure boot installation length (L) is the specified length. Insert a suitable tool into the large end of boot. Bleed air from boot to prevent boot deformation.

Boot installation length (L) : Refer to [FAX-31, "Drive Shaft"](#).

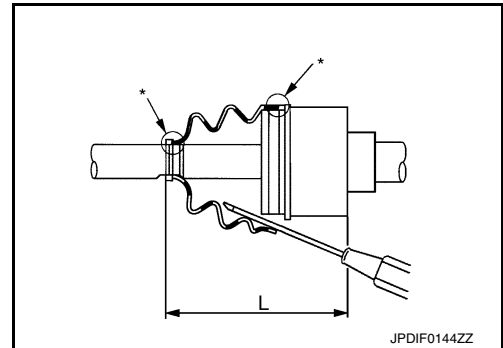

CAUTION:

- Boot may break if boot installation length is less than standard value.
- Be careful that suitable tool does not contact inside surface of boot.

8. Install new large and small boot bands securely using Tool.

Tool number : KV40107300 (—)

NOTE:

Do not reuse boot bands.

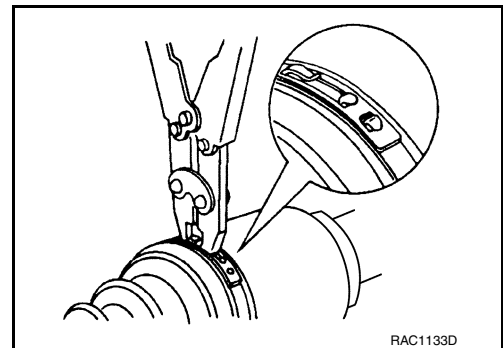

CAUTION:

Secure boot band so that dimension (M) meets specification as shown.

A
B
C
FAX
E
F
G
H
I
J
K
L
M
N
O
P

FRONT DRIVE SHAFT

< UNIT DISASSEMBLY AND ASSEMBLY >

Dimension (M) : Refer to [FAX-32. "Boot Bands"](#).

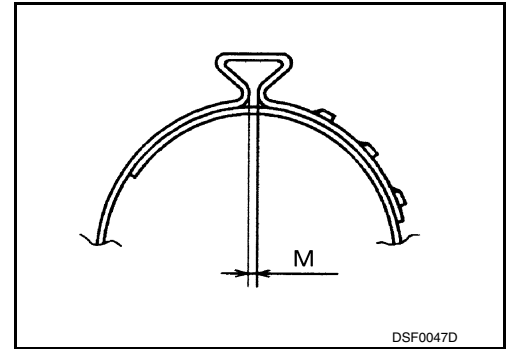

9. After installing housing and shaft, rotate boot to check whether or not the actual position is correct. If boot position is not correct, remove old boot bands then reposition the boot and secure with new boot bands.

Support Bearing

1. Install support bearing onto slide joint assembly.
2. Install snap ring.
3. Install dust shield.

Damper (if equipped)

1. Use new damper bands for installation.
2. Install damper from stationary-joint side while holding it securely.

Dimension (A) : Refer to [FAX-31. "Dynamic Damper"](#).

Dimension (B) : Refer to [FAX-31. "Dynamic Damper"](#).

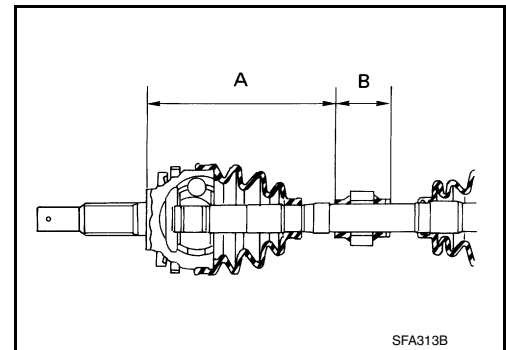

SERVICE DATA AND SPECIFICATIONS (SDS)

< SERVICE DATA AND SPECIFICATIONS (SDS)

SERVICE DATA AND SPECIFICATIONS (SDS)

SERVICE DATA AND SPECIFICATIONS (SDS)

Wheel Bearing

INFOID:000000009135453

Item	Standard
Axial end play	0.05 mm (0.002 in) or less

Drive Shaft

INFOID:000000009135454

FAX

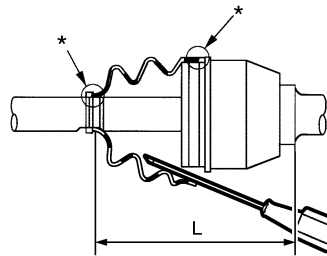

JPDIF0142ZZ

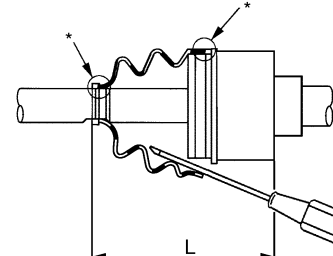

JPDIF0144ZZ

Joint type	Wheel side	Transaxle side
Grease quantity	115 ± 10 g (4.06 ± 0.35 oz)	190 ± 10 g (6.70 ± 0.35 oz)
Boots installed length (L)	135.1 mm (5.32 in)	177.9 mm (7.00 in)

* : Boot installation grooves

Dynamic Damper

INFOID:000000009135455

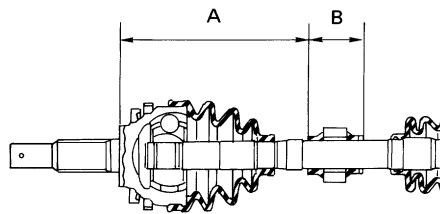

SFA313B

	FWD	
	LH	RH
Dimension (A)	230 ± 3 mm (9.06 ± 0.12 in)	—
Dimension (B)	70 mm (2.76 in)	—
	AWD	
	LH	RH
Dimension (A)	230 ± 3 mm (9.06 ± 0.12 in)	230 ± 3 mm (9.06 ± 0.12 in)
Dimension (B)	70 mm (2.76 in)	70 mm (2.76 in)

SERVICE DATA AND SPECIFICATIONS (SDS)

< SERVICE DATA AND SPECIFICATIONS (SDS)

Boot Bands

INFOID:000000009135456

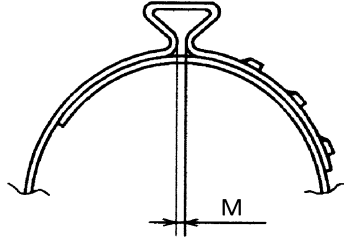

DSF0047D

Dimension (M)	1.0 - 4.0 mm (0.039 - 0.157 in)
---------------	---------------------------------