

SECTION **DMS**

DRIVE MODE SYSTEM

A
B
C
D
E
F
G
H
I
J
K
L
M
N
P

CONTENTS

Infiniti Drive Mode Selector	SYSTEM	7	F
PRECAUTION	INFINITI DRIVE MODE SELECTOR	7	G
	Infiniti Drive Mode Selector : System Description.....	7	
PRECAUTIONS	HANDLING PRECAUTION	9	H
Precaution for Supplemental Restraint System (SRS) "AIR BAG" and "SEAT BELT PRE-TENSIONER"	Infiniti Drive Mode Selector	9	
Precaution for Work	BASIC INSPECTION	10	I
PREPARATION	DIAGNOSIS AND REPAIR WORK FLOW	10	J
	Work Flow	10	
PREPARATION	DTC/CIRCUIT DIAGNOSIS	12	K
Special Service Tool	DRIVE MODE SELECT SWITCH CIRCUIT	12	L
SYSTEM DESCRIPTION	Diagnosis Procedure	12	
DESCRIPTION	Component Inspection	13	
Infiniti Drive Mode Selector	REMOVAL AND INSTALLATION	14	M
COMPONENT PARTS	DRIVE MODE SELECT SWITCH	14	N
Component Parts Location	Removal and Installation	14	
Drive Mode Select Switch			

DMS

PRECAUTION

PRECAUTIONS

Precaution for Supplemental Restraint System (SRS) "AIR BAG" and "SEAT BELT PRE-TENSIONER"

INFOID:000000011516667

The Supplemental Restraint System such as "AIR BAG" and "SEAT BELT PRE-TENSIONER", used along with a front seat belt, helps to reduce the risk or severity of injury to the driver and front passenger for certain types of collision. This system includes dual stage front air bag modules. The SRS system may only deploy one front air bag, depending on the severity of a collision and whether the front passenger seat is occupied. Information necessary to service the system safely is included in the SR and SB section of this Service Manual.

WARNING:

- To avoid rendering the SRS inoperative, which could increase the risk of personal injury or death in the event of a collision which would result in air bag inflation, all maintenance must be performed by an authorized NISSAN/INFINITI dealer.
- Improper maintenance, including incorrect removal and installation of the SRS, can lead to personal injury caused by unintentional activation of the system. For removal of Spiral Cable and Air Bag Module, see the SR section.
- Do not use electrical test equipment on any circuit related to the SRS unless instructed to in this Service Manual. SRS wiring harnesses can be identified by yellow and/or orange harnesses or harness connectors.

PRECAUTIONS WHEN USING POWER TOOLS (AIR OR ELECTRIC) AND HAMMERS

WARNING:

- When working near the Airbag Diagnosis Sensor Unit or other Airbag System sensors with the Ignition ON or engine running, DO NOT use air or electric power tools or strike near the sensor(s) with a hammer. Heavy vibration could activate the sensor(s) and deploy the air bag(s), possibly causing serious injury.
- When using air or electric power tools or hammers, always switch the Ignition OFF, disconnect the battery and wait at least three minutes before performing any service.

Precaution for Work

INFOID:000000011133037

- When removing or disassembling each component, be careful not to damage or deform it. If a component may be subject to interference, be sure to protect it with a shop cloth.
- When removing (disengaging) components with a screwdriver or similar tool, be sure to wrap the component with a shop cloth or vinyl tape to protect it.
- Protect the removed parts with a shop cloth and prevent them from being dropped.
- Replace a deformed or damaged clip.
- If a part is specified as a non-reusable part, always replace it with a new one.
- Be sure to tighten bolts and nuts securely to the specified torque.
- After installation is complete, be sure to check that each part works properly.
- Follow the steps below to clean components:
 - Water soluble dirt:
 - Dip a soft cloth into lukewarm water, wring the water out of the cloth and wipe the dirty area.
 - Then rub with a soft, dry cloth.
 - Oily dirt:
 - Dip a soft cloth into lukewarm water with mild detergent (concentration: within 2 to 3%) and wipe the dirty area.
 - Then dip a cloth into fresh water, wring the water out of the cloth and wipe the detergent off.
 - Then rub with a soft, dry cloth.
- Do not use organic solvent such as thinner, benzene, alcohol or gasoline.
- For genuine leather seats, use a genuine leather seat cleaner.

< PREPARATION >

PREPARATION

PREPARATION

Special Service Tool

INFOID:0000000011133038

The actual shape of the tools may differ from those illustrated here.

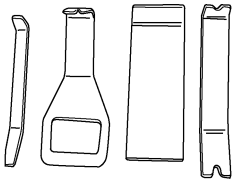
Tool number (TechMate No.) Tool name	Description
<p>— (J-46534) Trim Tool Set</p>  <p style="text-align: center; font-size: small;">AWJIA0463ZZ</p>	<p>Removing trim components</p>

A
B
C
D
E
F
G
H
I
J
K
L
M
N
P

DMS

SYSTEM DESCRIPTION

DESCRIPTION

Infiniti Drive Mode Selector

INFOID:000000011133039

- All the vehicles are equipped with an INFINITI drive mode selector which switches a vehicle mode among STANDARD, SPORT, ECO, and SNOW with the flick of a switch.
- The Infiniti drive mode selector changes a vehicle mode to the engine (including ECO pedal), transmission, and the active trace control function.

COMPONENT PARTS

< SYSTEM DESCRIPTION >

[Infiniti Drive Mode Selector]

COMPONENT PARTS

Component Parts Location

INFOID:000000011133040

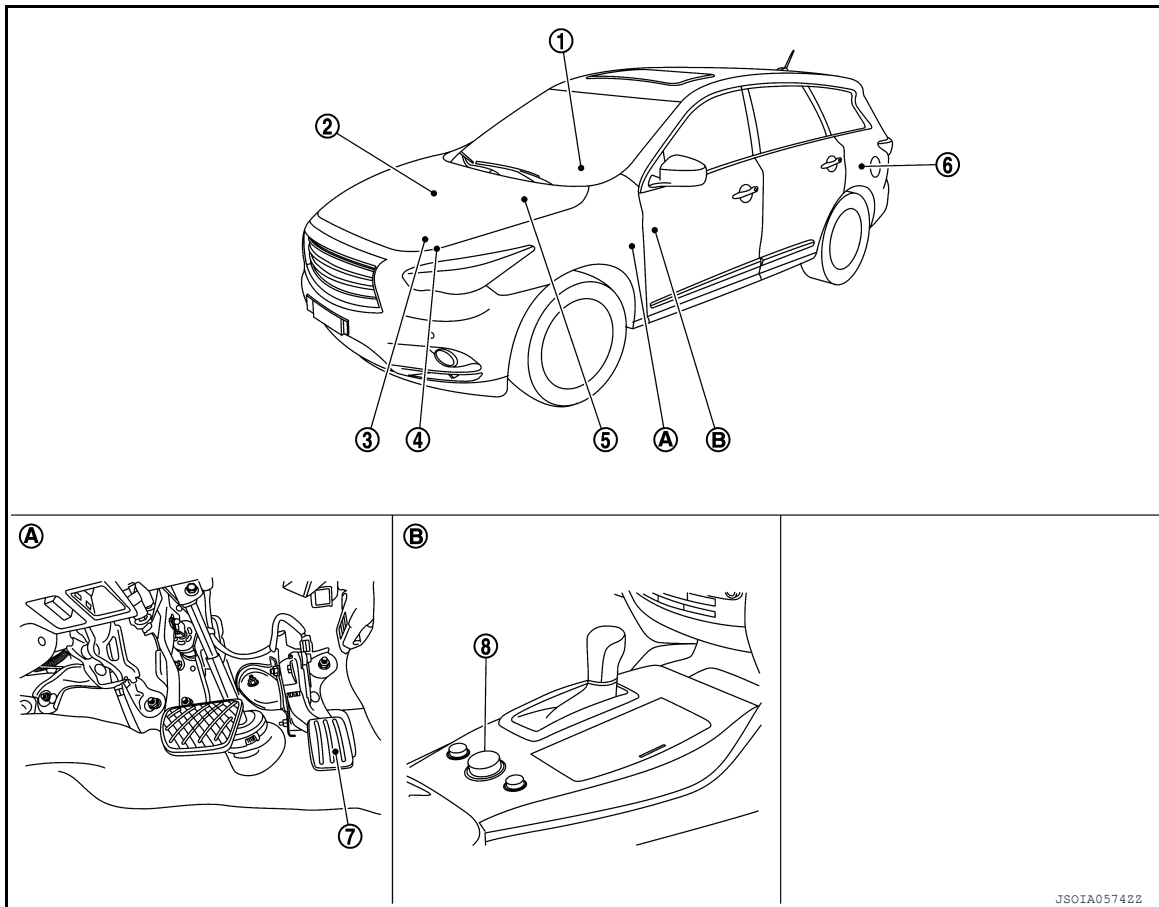

A. Around the pedal

B. Around the selector lever

No.	Part	Description
1	Combination meter	Displays a mode state on the vehicle information display, based on the mode state received from the A/C auto amp. For details of installation position, refer to MWI-6. "METER SYSTEM : Component Parts Location" .
2	ABS actuator and electric unit	Activates the ABS actuator, according to an active trace control function control signal received from the ADAS control unit. For details of installation position, refer to BRC-8. "Component Parts Location" .
3	TCM	<ul style="list-style-type: none"> Selects a shift pattern, based on a mode state received from the A/C auto amp. Transmits a mode state received from the A/C auto amp. to ECM. For details of installation position, refer to TM-14. "CVT CONTROL SYSTEM : Component Parts Location" (RE0F10E) or TM-228. "CVT CONTROL SYSTEM : Component Parts Location" (RE0F10J).
4	ECM	Receives a mode signal from TCM and controls throttle angle characteristics. For details of installation position, refer to EC-22. "ENGINE CONTROL SYSTEM : Component Parts Location" (except for Mexico) or EC-555. "ENGINE CONTROL SYSTEM : Component Parts Location" (for Mexico).
5	A/C auto amp.	Receives an ON/OFF state of each mode from the drive mode select switch and transmits the switch signal to TCM, combination meter and ADAS control unit via CAN communications. For details of installation position, refer to HAC-11. "FRONT AUTOMATIC AIR CONDITIONING SYSTEM : Component Parts Location" .

A
B
C
D
E
F
G
H
I
J
K
L
M
N
P

DMS

COMPONENT PARTS

< SYSTEM DESCRIPTION >

[Infiniti Drive Mode Selector]

No.	Part	Description
6	ADAS control unit	<ul style="list-style-type: none"> Controls the active trace control function, based on a mode state received from the A/C auto amp. Controls accelerator pedal reaction force of the accelerator pedal actuator, based on a ECO pedal reaction force control signal received from ECM. For details of installation position, refer to DAS-18. "Component Parts Location".
7	Accelerator pedal actuator	Applies reaction force to the accelerator pedal, based on an accelerator pedal reaction force control signal received from the ADAS control unit.
8	Drive mode select switch	Outputs an ON/OFF state of STANDARD, SPORT, ECO, or SNOW mode to the A/C auto amp.

Drive Mode Select Switch

INFOID:000000011133041

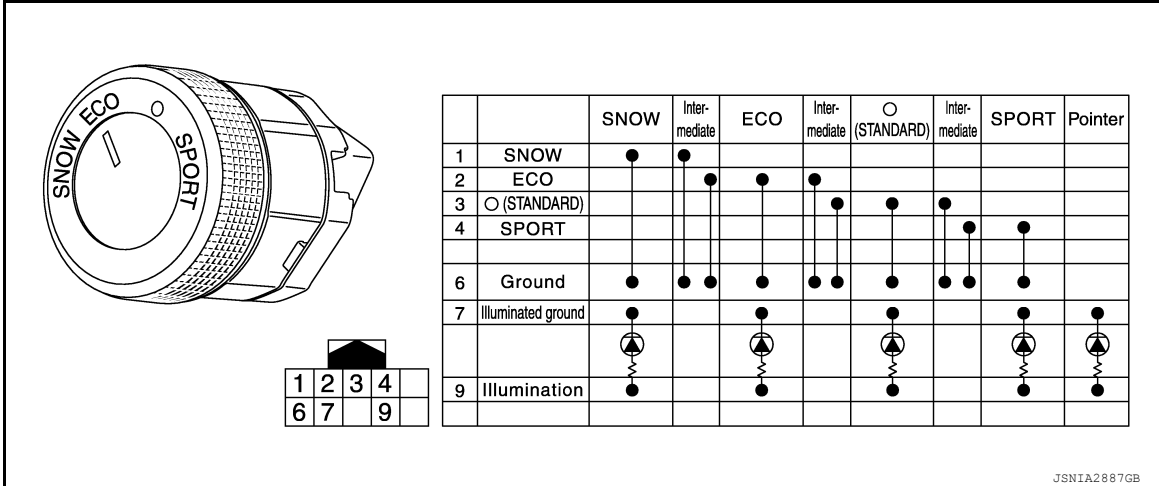

- 4-contact rotary type drive mode select switch is set on the upper part of the center console.
- Being connected to A/C auto amp., this switch allows to select STANDARD, SPORT, ECO, or SNOW mode.

SYSTEM

Infiniti Drive Mode Selector

Infiniti Drive Mode Selector : System Description

INFOID:000000011133042

SYSTEM DIAGRAM

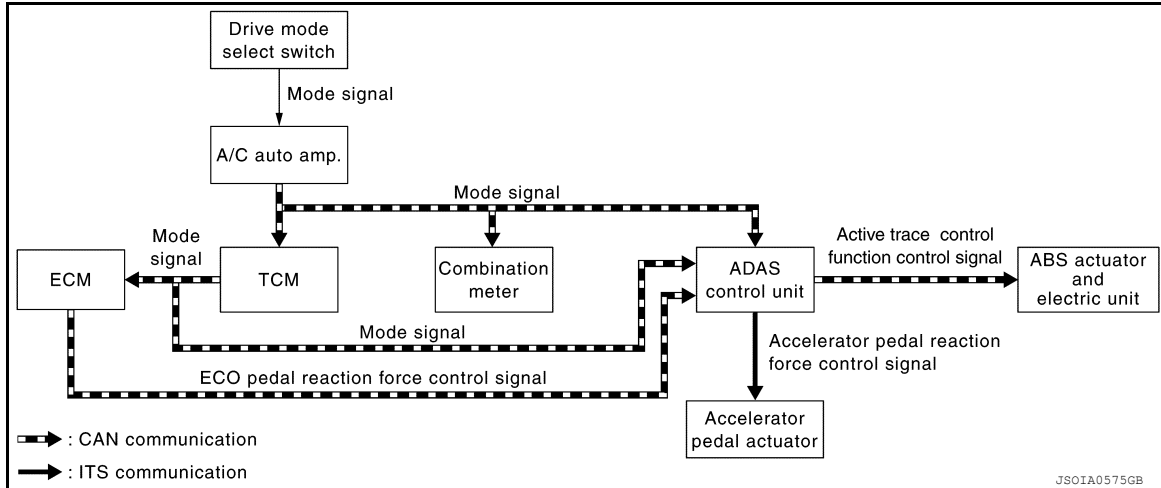

- The A/C auto amp. receives an operational state of the drive mode select switch and transmits a mode signal (See below.) to each unit via CAN communications.
 - STANDARD: ON/OFF
 - SPORT: ON/OFF
 - ECO: ON/OFF
 - SNOW: ON/OFF
- TCM transmits a mode state to ECM and ADAS control unit via CAN communications, based on a mode signal received from the A/C auto amp.
- ECM transmits an ECO pedal control signal to the ADAS control unit via CAN communications.
- The ADAS control unit controls pedal reaction force of the accelerator pedal actuator via ITS communications, based on an ECO pedal control signal received from ECM.
- The ADAS control unit receives a mode signal from the A/C auto amp. and changes the characteristics of the active trace control function via CAN communications with the ABS actuator and electric unit.

CONTROL DESCRIPTION

- The INFINITI drive mode selector switches a vehicle mode with the flick of a switch (Drive mode select switch) mounted on upper part of the center console and changes the control characteristics of the powertrain and chassis.
- The vehicle characteristics are controlled from the STANDARD mode (“●” position of the drive mode select switch) to any mode listed below:
 - SPORT: Changing the control characteristics of the transmission and active trace control function enables the use of high engine performance regions to obtain a light and crisp feel of the steering wheel.
 - ECO: Fuel economy is enhanced by changing the control characteristics of the engine transmission and using an ECO pedal.
 - SNOW: Changing the engine characteristics enables the obtainment of higher driving performance on roads with low coefficient of friction.

x: applicable

Items	Control Mode			Control
	SPORT	ECO	SNOW	
Engine		x	x	<ul style="list-style-type: none"> • Changes throttle angle characteristics. • Controls the lighting of the ECO drive indicator lamp. (Only ECO turns ON.)
Transmission	x	x		Selects shift pattern.
Combination meter	x	x	x	Pops up a mode state.
Active trace control function*	x			Changes the characteristics of the active trace control function.
ECO pedal*		x		Controls reaction force of the accelerator pedal.

A
B
C
D
E
F
G
H
I
J
K
L
M
N
P

SYSTEM

< SYSTEM DESCRIPTION >

[Infiniti Drive Mode Selector]

- *: The application of the active trace control function and ECO pedal is only for vehicles with DCA (distance control assist).

ENGINE TRANSMISSION CONTROL

- For further information on engine control, refer to [EC-62, "Infiniti Drive Mode Selector : System Description"](#) (except for Mexico) or [EC-589, "Infiniti Drive Mode Selector : System Description"](#) (for Mexico).
- For further information on transmission control, refer to [TM-43, "Infiniti Drive Mode Selector : System Description"](#) (RE0F10E) or [TM-257, "Infiniti Drive Mode Selector : System Description"](#) (RE0F10J).

ECO DRIVE INDICATOR

- This system supports ECO driving by controlling the ECO drive indicator lamp in the combination meter, according to an accelerator pedal depression during ECO mode.
- The ECO drive indicator lamp changes depending on the state of the fuel-efficient region, fuel-efficient limit region, or fuel-efficient region excess.

Driving condition	ECO drive indicator (Color)
Within the ECO drive range.	ON (Green)
Likely over the ECO drive range.*	Blink (Green)*
Outside the ECO drive range.	OFF
Low speed region [approx. 3.2 km/h (2 MPH) or less] and high speed region [approx. 144 km/h (90 MPH) or more].	

*: With ECO pedal

ACTIVE TRACE CONTROL FUNCTION

- SPORT mode is introduced.
- In SPORT mode, the changing of brake control characteristics allows the driver to control the vehicle motion more than in STANDARD mode.

ECO PEDAL CONTROL

- This system supports ECO driving by applying a load to the accelerator pedal according to an accelerator pedal operation during ECO mode.
- Reaction force to the accelerator pedal can be switched in two settings between STANDARD and SOFT. Pedal reaction force to the accelerator pedal can be set to OFF, as necessary. (Switch the settings on the NAVI screen.)
- ECO pedal control and ECO drive indicator lamp are interlocked each other to support ECO driving.
- For further information on ECO pedal control, refer to [EC-62, "Infiniti Drive Mode Selector : System Description"](#) (except for Mexico) or [EC-589, "Infiniti Drive Mode Selector : System Description"](#) (for Mexico).

COMBINATION METER CONTROL

A mode state of the INFINITI drive mode selector is displayed on the information display built in the meter.

Drive mode indication pattern

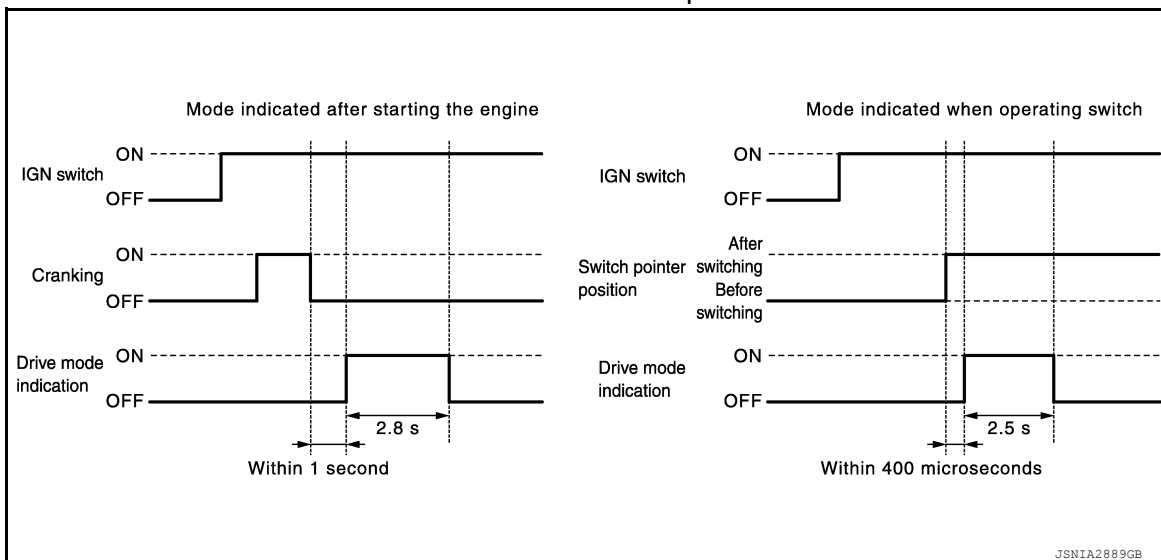

HANDLING PRECAUTION

Infiniti Drive Mode Selector

INFOID:000000011133043

ECO DRIVE INDICATOR LAMP CONTROL

ECO drive indicator lamp turns OFF under the following conditions.

- While driving at low speeds [3.2 km/h (2 MPH) or less] or high speeds [144 km/h (90 MPH) or more].
- Intelligent cruise control is in operation.
- Selector lever is in R range.

ECO PEDAL CONTROL

When switching from ECO mode to the other mode by operating the drive mode select switch, ECO pedal reaction force is generated in common with ECO mode until the accelerator pedal is released.

- ECO pedal reaction force is not generated under the following conditions.
 - Intelligent cruise control is in operation.
 - Accelerator pedal is depressed quickly
 - Selector lever is in N or R range.
 - ECO pedal reaction force setting is OFF.

NOTE:

ECO pedal control is only for vehicles with an intelligent pedal (distance control assist).

ENGINE OUTPUT CHARACTERISTICS AFTER SWITCHING MODE

- Engine output characteristics after switching mode by operating the drive mode select switch are as follows.
 - After switching mode to a mode that engine output increase, engine output characteristics are changed by releasing the accelerator pedal.
 - After switching mode to a mode that engine output decreases, engine output characteristics are changed immediately.
- When an accelerator angle is constant, engine output characteristics are as follows.
 - SPORT = STANDARD > ECO > SNOW

Output characteristics of each mode

Control mode	Engine output
SPORT	Normal*
STANDARD	Normal
ECO	Decrease
SNOW	Decrease (More reduction than ECO mode)

*: Not controlled by engine control system.

A
B
C
D
E
F
G
H
I
J
K
L
M
N
P



DIAGNOSIS AND REPAIR WORK FLOW

< BASIC INSPECTION >

[Infiniti Drive Mode Selector]

BASIC INSPECTION

DIAGNOSIS AND REPAIR WORK FLOW

Work Flow

INFOID:000000011133044

OVERALL SEQUENCE

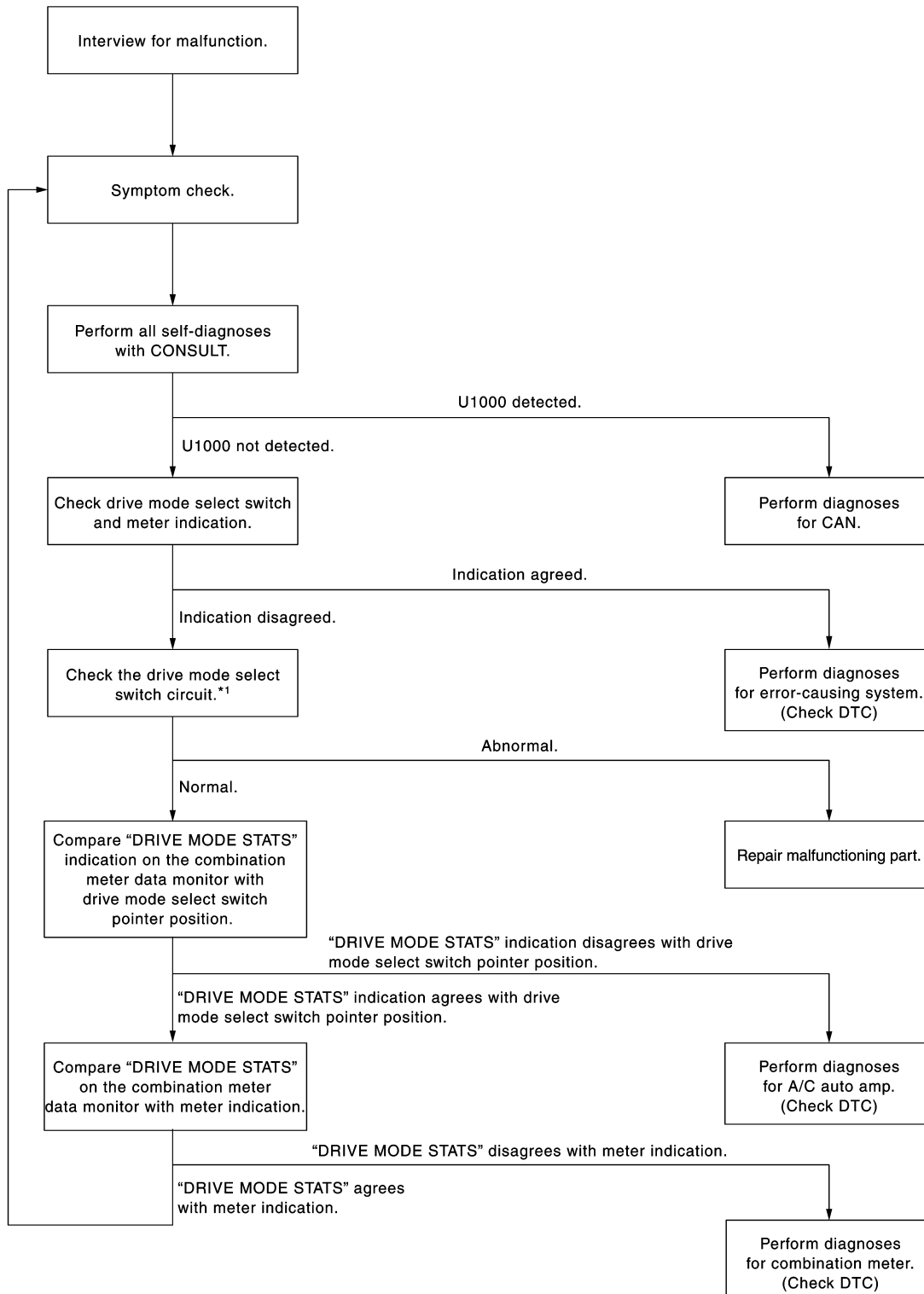

*1: Refer to [DMS-12, "Diagnosis Procedure"](#).

JSNIA4368GB

DIAGNOSIS AND REPAIR WORK FLOW

< BASIC INSPECTION >

[Infiniti Drive Mode Selector]

DETAILED FLOW

1. INTERVIEW FOR MALFUNCTION

Interview the customer to obtain as much information as possible about the conditions and environment under which the malfunction occurred.

>> GO TO 2.

2. SYMPTOM CHECK

1. Check the symptom based on the information obtained from the customer.
2. Perform "All DTC Reading" with CONSULT.

Is U1000 detected?

- YES >> Perform CAN communication trouble diagnosis.
NO >> GO TO 3.

3. CHECK DRIVE MODE SELECT SWITCH AND METER INDICATION

Compare combination meter indication with drive mode select switch pointer position.

Does switch position accord with meter indication?

- YES >> Perform trouble diagnosis of malfunctioning system (DTC confirmation).
NO >> GO TO 4.

4. CHECK THE DRIVE MODE SELECT SWITCH CIRCUIT

Perform inspection of drive mode select switch circuit. Refer to [DMS-12, "Diagnosis Procedure"](#).

Is inspection result normal?

- YES >> GO TO 5.
NO >> Repair or replace malfunctioning parts.

5. CHECK THE DATA MONITOR OF COMBINATION METER

Compare "DRIVE MODE STATS" indication on the combination meter data monitor with drive mode select switch pointer position.

Does switch position accord with data monitor indication?

- YES >> GO TO 6.
NO >> Perform trouble diagnosis of A/C auto amp. Refer to [MWI-17, "CONSULT Function \(METER/M&A\)"](#).

6. CHECK THE DATA MONITOR OF COMBINATION METER

Compare "DRIVE MODE STATS" indication on the combination meter data monitor with combination meter indication.

Does meter indication accord with data monitor indication?

- YES >> GO TO 2.
NO >> Perform trouble diagnosis of combination meter. Refer to [MWI-17, "CONSULT Function \(METER/M&A\)"](#).

A
B
C
D
E
F
G
H
I
J
K
L
M
N
P

DMS

DRIVE MODE SELECT SWITCH CIRCUIT

< DTC/CIRCUIT DIAGNOSIS >

[Infiniti Drive Mode Selector]

DTC/CIRCUIT DIAGNOSIS

DRIVE MODE SELECT SWITCH CIRCUIT

Diagnosis Procedure

INFOID:000000011133045

Regarding Wiring Diagram information, refer to [TM-65. "Wiring diagram"](#) (RE0F10E) or [TM-279. "Wiring diagram"](#) (RE0F10J).

1. CHECK CONTINUITY DRIVE MODE SELECT SWITCH SIGNAL CIRCUIT

1. Turn ignition switch OFF.
2. Disconnect the drive mode select switch connector and A/C auto amp. connector.
3. Check continuity between drive mode select switch harness connector and A/C auto amp. harness connector.

Drive mode select switch		A/C auto amp.		Continuity
Connector	Terminal	Connector	Terminal	
M211	1	M50	10	Existed
	2		29	
	3		11	
	4		31	

4. Check continuity between drive mode select switch harness connector and ground.

Drive mode select switch		Ground	Continuity
Connector	Terminal		
M211	1	Ground	Not existed
	2		
	3		
	4		

Is the inspection result normal?

YES >> GO TO 2

NO >> Repair harness or connector

2. CHECK VOLTAGE OF A/C AUTO AMP.

1. Connect the A/C auto amp. connector.
2. Check voltage between A/C auto amp. harness connector and ground.

Terminals				Voltage (Approx.)
(+)		(-)		
A/C auto amp.				12 V
Connector	Terminal	Ground		
M50	10			
	29			
	11			
	31			

Is the inspection result normal?

YES >> GO TO 3

NO >> Replace A/C auto amp. Refer to [HAC-161. "Removal and Installation"](#).

3. CHECK DRIVE MODE SELECT SWITCH GROUND CIRCUIT

DRIVE MODE SELECT SWITCH CIRCUIT

< DTC/CIRCUIT DIAGNOSIS >

[Infiniti Drive Mode Selector]

1. Check continuity drive mode select switch harness connector and ground.

Drive mode select switch		Ground	Continuity
Connector	Terminal		
M211	6		Existed

Is the inspection result normal?

- YES >> Check drive mode select switch. Refer to [DMS-13. "Component Inspection"](#).
NO >> Repair harness or connector.

Component Inspection

INFOID:000000011133046

1. DRIVE MODE SELECT SWITCH INSPECTION

1. Turn ignition switch OFF.
2. Disconnect drive mode select switch connector.
3. Check continuity between drive mode select switch connector terminal 6 and drive mode select switch connector terminals 1, 2, 3 and 4.

Drive mode select switch		Switch position	Continuity
Terminals			
6	1	SNOW	Existed
	2	ECO	
	3	STANDARD	
	4	SPORT	

Is the inspection result normal?

- YES >> Inspection
NO >> Replace drive mode select switch. Refer to [DMS-14. "Removal and Installation"](#).

A
B
C
D
E
F
G
H
I
J
K
L
M
N
P

DMS

REMOVAL AND INSTALLATION

DRIVE MODE SELECT SWITCH

Removal and Installation

INFOID:000000011133047

REMOVAL

1. Remove the shift selector handle. Refer to [TM-190, "Exploded View"](#).
2. Remove the center console upper side finisher LH and RH. Refer to [IP-18, "Exploded View"](#).
3. Remove the shift selector finisher. Refer to [IP-18, "Exploded View"](#).
4. Lift the shift selector finisher and disconnect the harness connectors.
5. Remove the shift selector finisher from vehicle.
6. Remove the drive mode select switch (2) from the shift selector finisher (1) by prying the locking tabs, and push the switch through the top-side.

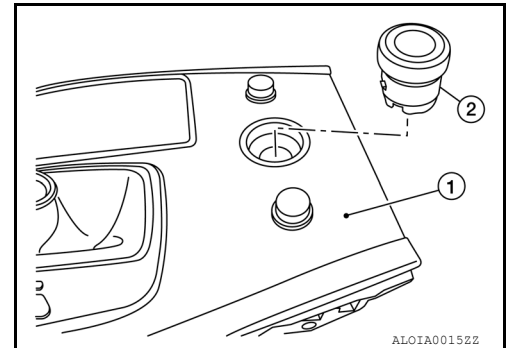

INSTALLATION

Installation is in the reverse order of removal.