

A
FL
C
D
E
F
G
H
I
J
K
L
M
N
O
P

SECTION **FL**

FUEL SYSTEM

CONTENTS

PRECAUTION	EVAP CANISTER
2	18
PRECAUTIONS	Exploded View
2	18
Precaution for Supplemental Restraint System (SRS) "AIR BAG" and "SEAT BELT PRE-TENSIONER"	Removal and Installation
2	18
General Precaution	Inspection
2	19
PREPARATION	EVAP CANISTER FILTER
4	20
PREPARATION	Exploded View
4	20
Special Service Tool	Removal and Installation
4	20
Commercial Service Tool	EVAP CANISTER VENT CONTROL VALVE ...
4	21
PERIODIC MAINTENANCE	Exploded View
5	21
FUEL SYSTEM	Removal and Installation
5	21
Inspection	EVAP CONTROL SYSTEM PRESSURE SENSOR
5	22
Quick Connector	Exploded View
5	22
REMOVAL AND INSTALLATION	Removal and Installation
6	22
FUEL LEVEL SENSOR UNIT, FUEL FILTER AND FUEL PUMP ASSEMBLY	DISASSEMBLY AND ASSEMBLY
6	23
Exploded View	FUEL LEVEL SENSOR UNIT
6	23
Removal and Installation	Disassembly and Assembly
6	23
FUEL TANK	SERVICE DATA AND SPECIFICATIONS (SDS)
13	25
Exploded View	SERVICE DATA AND SPECIFICATIONS (SDS)
13	25
Removal and Installation	Fuel Tank
13	25

PRECAUTIONS

< PRECAUTION >

PRECAUTION

PRECAUTIONS

Precaution for Supplemental Restraint System (SRS) "AIR BAG" and "SEAT BELT PRE-TENSIONER"

INFOID:000000011146236

The Supplemental Restraint System such as "AIR BAG" and "SEAT BELT PRE-TENSIONER", used along with a front seat belt, helps to reduce the risk or severity of injury to the driver and front passenger for certain types of collision. This system includes dual stage front air bag modules. The SRS system may only deploy one front air bag, depending on the severity of a collision and whether the front passenger seat is occupied. Information necessary to service the system safely is included in the SR and SB section of this Service Manual.

WARNING:

- To avoid rendering the SRS inoperative, which could increase the risk of personal injury or death in the event of a collision which would result in air bag inflation, all maintenance must be performed by an authorized NISSAN/INFINITI dealer.
- Improper maintenance, including incorrect removal and installation of the SRS, can lead to personal injury caused by unintentional activation of the system. For removal of Spiral Cable and Air Bag Module, see the SR section.
- Do not use electrical test equipment on any circuit related to the SRS unless instructed to in this Service Manual. SRS wiring harnesses can be identified by yellow and/or orange harnesses or harness connectors.

PRECAUTIONS WHEN USING POWER TOOLS (AIR OR ELECTRIC) AND HAMMERS

WARNING:

- When working near the Airbag Diagnosis Sensor Unit or other Airbag System sensors with the Ignition ON or engine running, DO NOT use air or electric power tools or strike near the sensor(s) with a hammer. Heavy vibration could activate the sensor(s) and deploy the air bag(s), possibly causing serious injury.
- When using air or electric power tools or hammers, always switch the Ignition OFF, disconnect the battery and wait at least three minutes before performing any service.

General Precaution

INFOID:000000011146237

WARNING:

When replacing fuel line parts, be sure to observe the following.

- Put a "CAUTION: FLAMMABLE" sign in the work area.
- Be sure to work in a well ventilated area and have a CO² fire extinguisher.
- Do not smoke while working on the fuel system. Keep open flames and sparks away from the work area.

CAUTION:

- Before removing fuel line parts, carry out the following procedures:
 - Put drained fuel in an explosion-proof container and put the lid on securely. Keep the container in safe area.
 - Release fuel pressure from the fuel lines. Refer to [EC-176, "Work Procedure"](#) (For United States and Canada or [EC-693, "Work Procedure"](#) (For Mexico).
 - Disconnect the battery ground cable.
- Always replace O-rings and clamps with new ones.
- Do not kink or twist tubes when they are being installed.
- Do not tighten hose clamps excessively to avoid damaging hoses.

PRECAUTIONS

< PRECAUTION >

Tighten high-pressure rubber hose clamp so that clamp end is 3 mm (0.12 in) from hose end.
Tightening torque specifications are the same for all rubber hose clamps.
Ensure that screw does not contact adjacent parts.

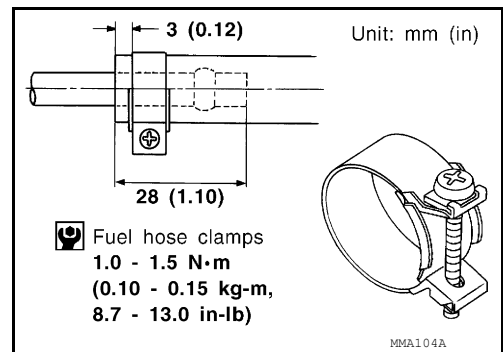

- After connecting the fuel tube quick connectors, make sure the quick connectors are secure.
Check that the connector and resin tube do not contact any adjacent parts.
- a) Apply fuel pressure to the fuel system by turning the ignition switch to ON (without starting the engine). Then check for fuel leaks at the fuel tube connections.
- b) Start the engine and rev the engine, then check for fuel leaks at the fuel tube connections.
- After installing the tubes, run the engine and check for fuel leaks at the connections.
- Use only a Genuine NISSAN fuel filler cap as a replacement. If an incorrect fuel filler cap is used, the MIL may come on.
- For servicing "Evaporative Emission System" parts, refer to [EC-584, "EVAPORATIVE EMISSION SYSTEM : System Description"](#).

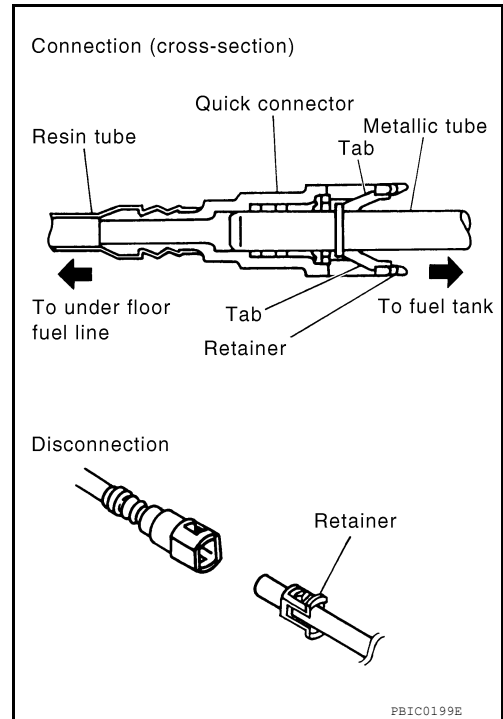

PREPARATION

< PREPARATION >

PREPARATION

PREPARATION

Special Service Tool

INFOID:000000011146238

The actual shape of the tools may differ from those illustrated here.

Tool number (TechMate No.) Tool name	Description
KV101207S0 (—) Unified fuel lock ring wrench	Removing and installing fuel tank lock ring
— (J-45747) Fuel tank lock ring wrench	

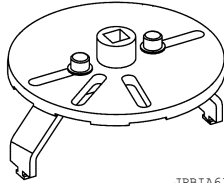

JPBIA6384ZZ

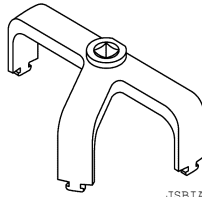

JSBIA1952ZZ

Commercial Service Tool

INFOID:000000011146239

Tool name	Description
Power tool	Loosening nuts, screws and bolts



PIIB1407E

FUEL SYSTEM

< PERIODIC MAINTENANCE >

PERIODIC MAINTENANCE

FUEL SYSTEM

Inspection

Inspect fuel lines, fuel filler cap and fuel tank for improper attachment, leaks, cracks, damage, loose connections, chafing or deterioration.

If necessary, repair or replace damaged parts.

INFOID:000000011146240

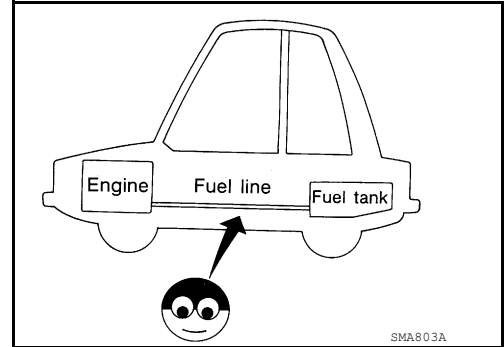

Quick Connector

CAUTION:

- After connecting fuel tube quick connectors, make sure quick connectors are secure. Ensure that connector and resin tube do not contact any adjacent parts.

INFOID:000000011146241

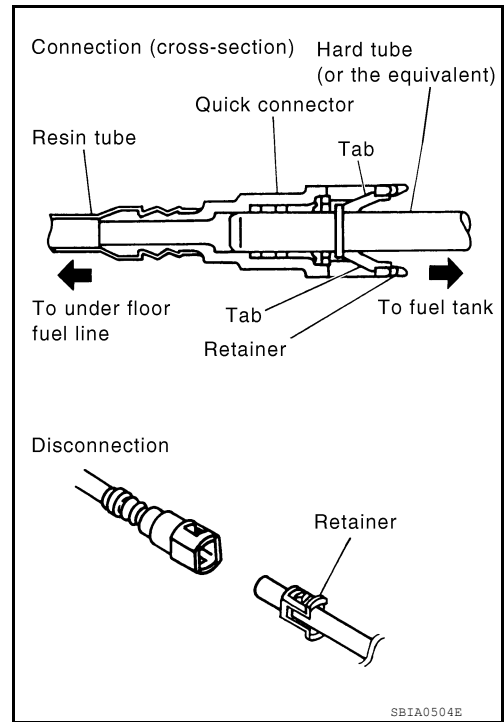

A
FL
C
D
E
F
G
H
I
J
K
L
M
N
O
P

FUEL LEVEL SENSOR UNIT, FUEL FILTER AND FUEL PUMP ASSEMBLY

< REMOVAL AND INSTALLATION >

REMOVAL AND INSTALLATION

FUEL LEVEL SENSOR UNIT, FUEL FILTER AND FUEL PUMP ASSEMBLY

Exploded View

INFOID:000000011146242

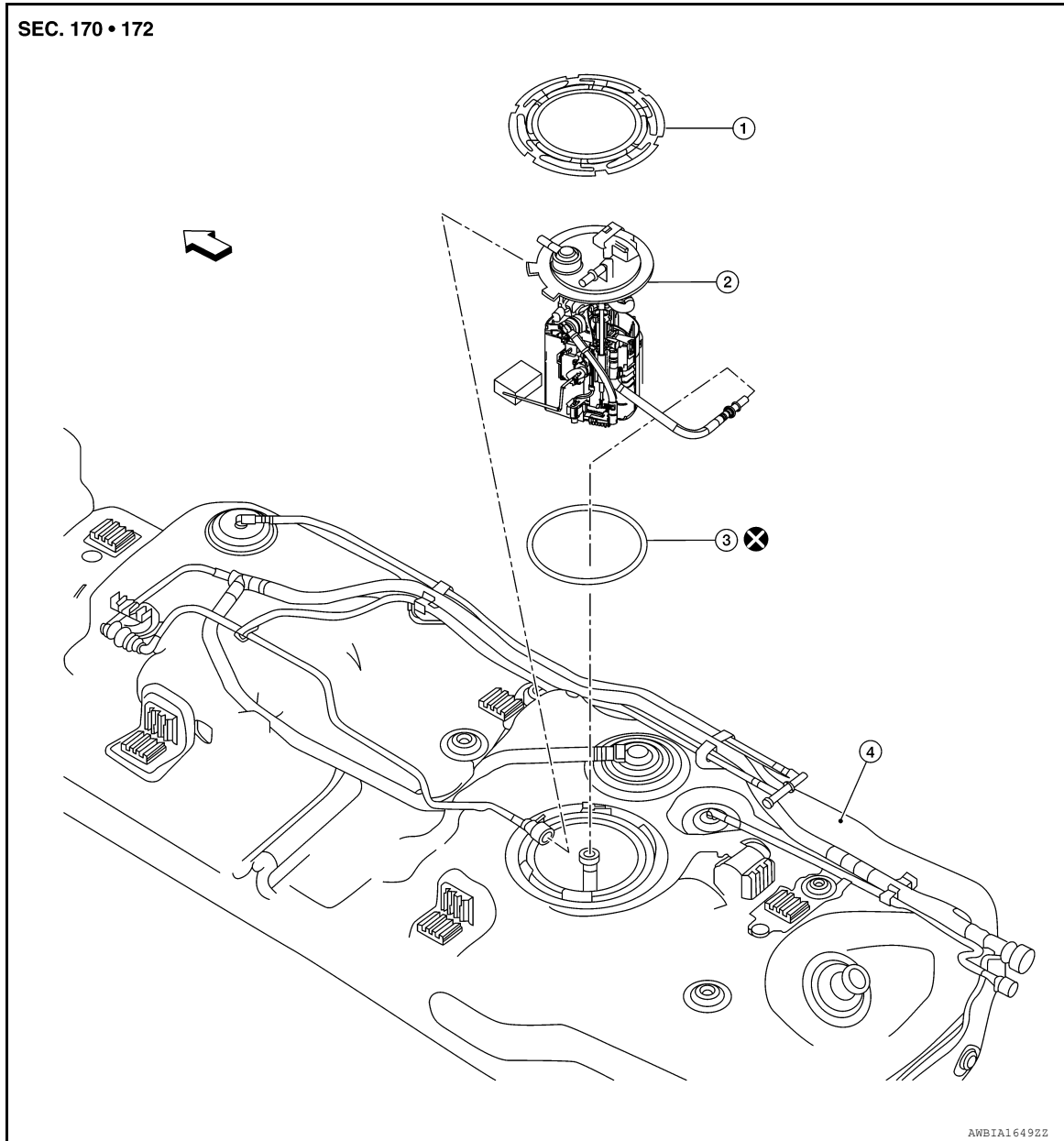

- 1. Lock ring
 - 2. Fuel level sensor, fuel filter and fuel pump assembly
 - 3. O-ring
 - 4. Fuel tank
- ↶ Front

Removal and Installation

INFOID:000000011146243

WARNING:

Read "General Precautions" before working on the fuel system. Refer to [FL-2, "General Precaution"](#).

NOTE:

When removing components such as hoses, tubes/lines, etc., cap or plug openings to prevent fluid from spilling.

FUEL LEVEL SENSOR UNIT, FUEL FILTER AND FUEL PUMP ASSEMBLY

< REMOVAL AND INSTALLATION >

REMOVAL

1. Unscrew the fuel filler cap to release the pressure inside the fuel tank.
2. Release the fuel pressure from the fuel lines. Refer to [EC-693, "Work Procedure"](#).
3. Disconnect the battery negative terminal. Refer to [EC-176, "Work Procedure"](#) (For United States and Canada) or [EC-693, "Work Procedure"](#) (For Mexico).
4. Remove both second row (LH) bench seat front slide covers. Refer to [SE-123, "Exploded View"](#).
5. Position the second row (LH) bench seat to full forward position.
6. Remove both second row (LH) bench seat rear slide covers. Refer to [SE-123, "Exploded View"](#).
7. Position and secure the carpet to gain access to the fuel pump inspection hole cover.

CAUTION:

Cover the immediate area surrounding the fuel pump inspection hole cover with plastic to avoid gasoline damage to the carpet.

8. Remove the center floor duct (LH). Refer to [VTL-13, "CENTER FLOOR DUCT : Removal and Installation - Center Floor Duct"](#).
9. Turn the four retainers (A) 90 degrees to disengage the clips and remove the fuel pump inspection hole cover.

⇐ :Front

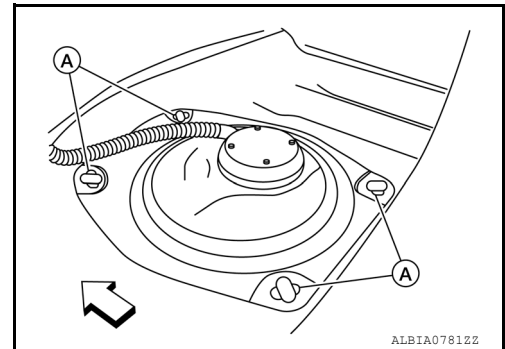

10. Disconnect the fuel level sensor, fuel filter, and fuel pump assembly harness connector (A), EVAP hose connector (C), and the fuel feed hose connector (B) from the fuel level sensor unit, fuel filter, and fuel pump assembly.

⇐ : Front

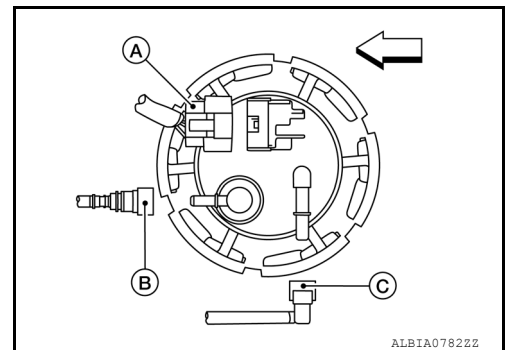

Disconnect the quick connector as follows:

- Hold the sides of the connector, push in tabs and pull out the tube.
- If the connector and the tube are stuck together, push and pull several times until they start to move. Then disconnect them by pulling.

CAUTION:

- **The tube can be removed when the tabs are completely depressed. Do not twist it more than necessary.**
- **Do not use any tools to remove the quick connector.**
- **Keep the resin tube away from heat. Be especially careful when welding near the tube.**
- **Prevent acid liquid such as battery electrolyte, etc. from getting on the resin tube.**
- **Do not bend or twist the tube during installation and removal.**
- **Only when the tube is replaced, remove the remaining retainer on the tube or fuel level sensor, fuel filter, and fuel pump assembly.**
- **When the tube or fuel level sensor, fuel filter, and fuel pump assembly is replaced, also replace the retainer with a new one (green colored retainer).**

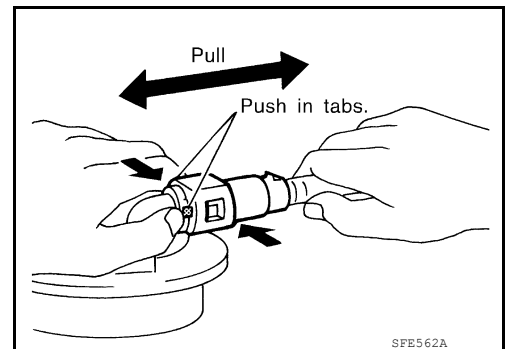

FUEL LEVEL SENSOR UNIT, FUEL FILTER AND FUEL PUMP ASSEMBLY

< REMOVAL AND INSTALLATION >

- To keep the connecting portion clean and to avoid damage and foreign materials, cover them completely with plastic bags or something similar.

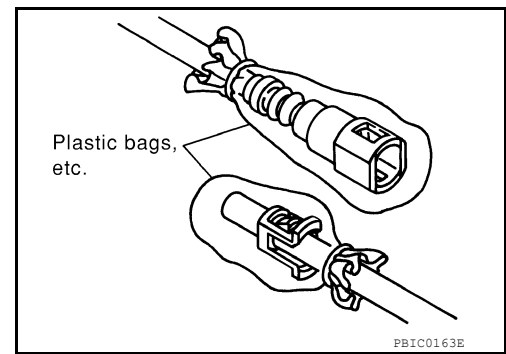

11. Remove the lock ring from the fuel level sensor, fuel filter, and fuel pump assembly.
 - Remove the lock ring using Tool (A).

Tool number (A) : — (J-45747) (shown)
: KV101207S0 (—)

⇐ : Front

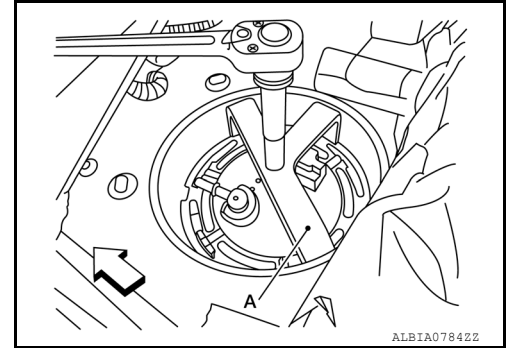

- Prior to removal, observe the alignment between the fuel level sensor, fuel filter, and fuel pump assembly tabs (A) and the matching marks (C) on the fuel tank as shown. This alignment is necessary for proper installation.

(B) : Retainer pawl

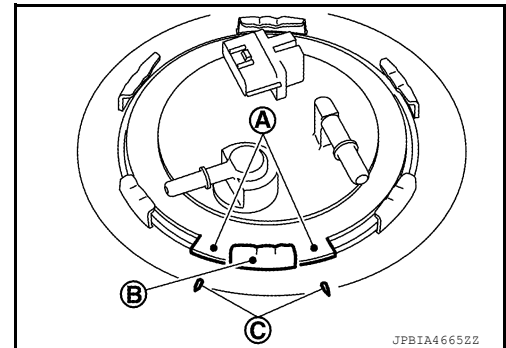

12. Raise the fuel level sensor, fuel filter, and fuel pump assembly high enough to gain access and disconnect the transfer tube connector (A).

CAUTION:

Do not pull on the transfer tube or damage to the fuel tank can occur.

13. Remove the fuel level sensor, fuel filter, and fuel pump assembly and O-ring. Discard the O-ring.

CAUTION:

- Do not bend the float arm during removal.
- Do not reuse the O-ring.

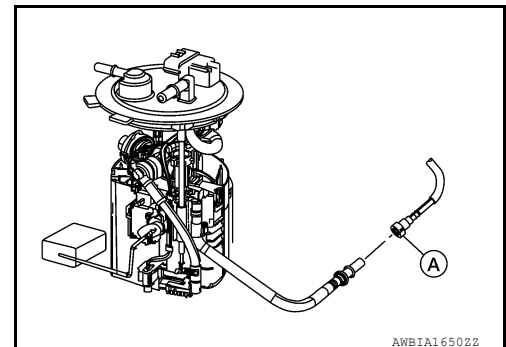

INSPECTION AFTER REMOVAL

Inspect the fuel level sensor, fuel filter, and fuel pump assembly for any defects and foreign materials. Replace as necessary.

INSTALLATION

1. Install the fuel level sensor, fuel filter, and fuel pump assembly with the following procedure.

CAUTION:

- It is important that the fuel level sensor, fuel filter, and fuel pump assembly be installed carefully, according to the method in this step to prevent the transfer hose from being pinched under the fuel pump and to ensure it is routed correctly inside the tank.
- Do not reuse O-ring.

FUEL LEVEL SENSOR UNIT, FUEL FILTER AND FUEL PUMP ASSEMBLY

< REMOVAL AND INSTALLATION >

NOTE:

Transfer hose (1) should be routed as shown.

↩ : Front

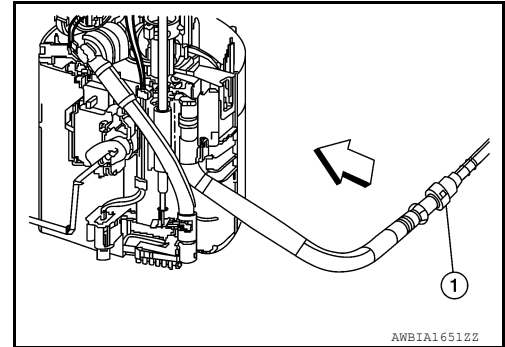

- Obtain a piece of plastic or nylon packing strap approximately 91cm (35.8 in)
 - Packing strap is commonly used to reinforce boxes for shipping.
- Loop the packing strap (2) around the transfer hose as shown.
 - Position the strap ends toward the passenger side.
 - Use your fingers to put a bend (1) in the strap near the transfer hose (3). This will help keep the strap in place.

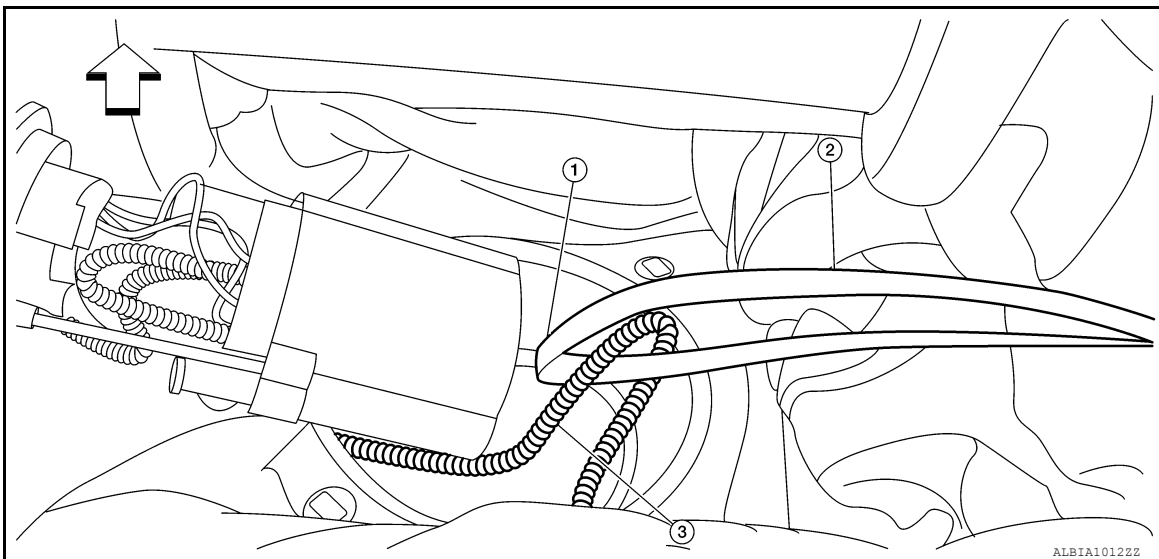

↩ : Front

- Lower the transfer hose and fuel level sensor unit, fuel filter and fuel pump assembly into the tank keeping the strap looped around the transfer hose.

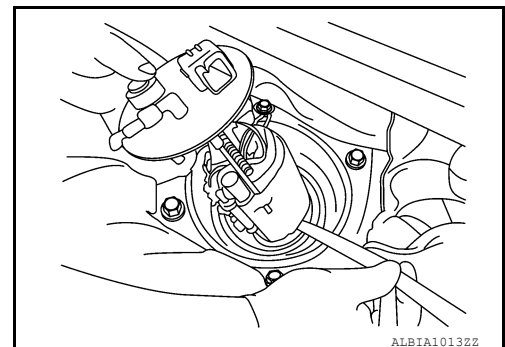

FUEL LEVEL SENSOR UNIT, FUEL FILTER AND FUEL PUMP ASSEMBLY

< REMOVAL AND INSTALLATION >

- d. With the fuel level sensor unit, fuel filter and fuel pump assembly in the tank, turn 1/4 turn clockwise so the fuel feed tube (1) is pointing toward the driver side.
- The fuel level sensor unit, fuel filter and fuel pump assembly should now be oriented to the installed position.

⇐ : Front

(2) : Packing strap

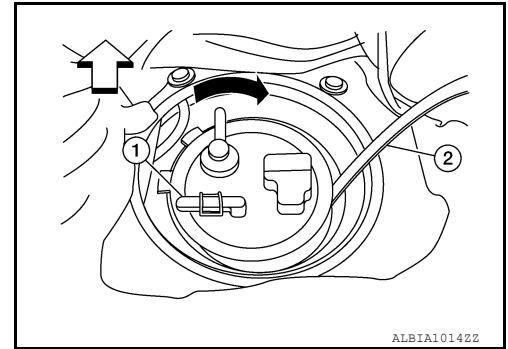

- e. Tilt the top of the fuel pump toward the driver side.
- f. Pull up on the packing strap (2) (pull the transfer hose up) just enough to see the transfer hose (1).

NOTE:

If you are unable to pull the transfer hose so it can be seen as shown, remove the fuel level sensor, fuel filter and fuel pump assembly from the tank and restart from the beginning of INSTALLATION.

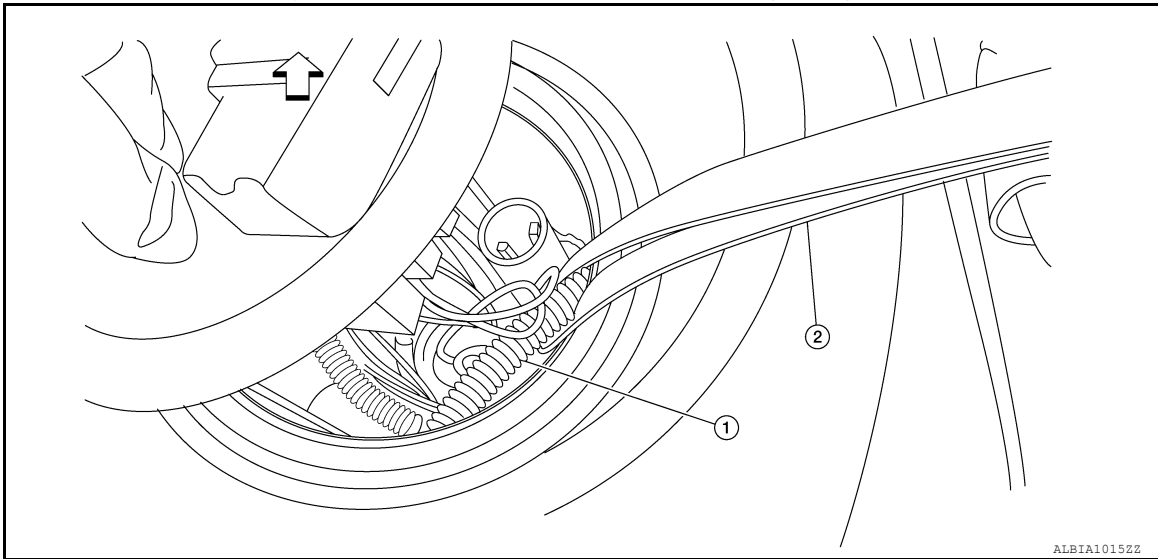

⇐ : Front

- g. Hold the fuel pump down so the bottom of the pump stays against the bottom of the tank.
- h. While holding the pump down, pull out the packing strap, pull towards the passenger side (➡).
- Make sure the O-ring is still in place.

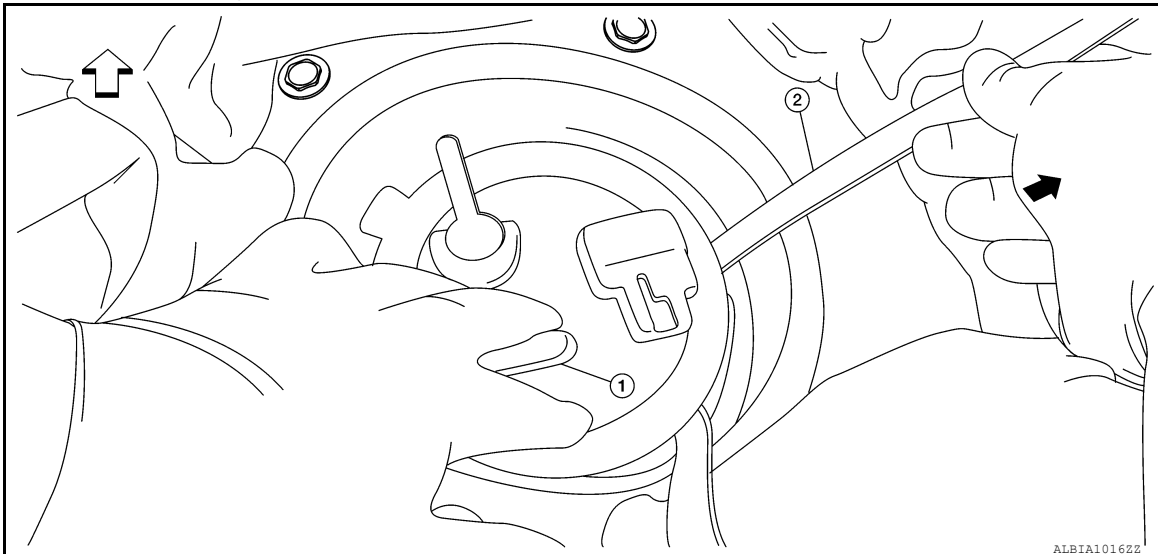

FUEL LEVEL SENSOR UNIT, FUEL FILTER AND FUEL PUMP ASSEMBLY

< REMOVAL AND INSTALLATION >

↩ : Front

- i. Continue to hold down the fuel pump while installing the fuel pump lock ring (turn clockwise) using Tool.

NOTE:

- If the fuel level sensor, fuel filter and fuel pump assembly is allowed to lift off of the bottom of the fuel tank the transfer hose may slide under it.
- If the fuel level sensor, fuel filter and fuel pump assembly lifts off the bottom of the tank before the lock ring is installed, remove the fuel level sensor, fuel filter and fuel pump assembly and restart from the beginning of INSTALLATION.

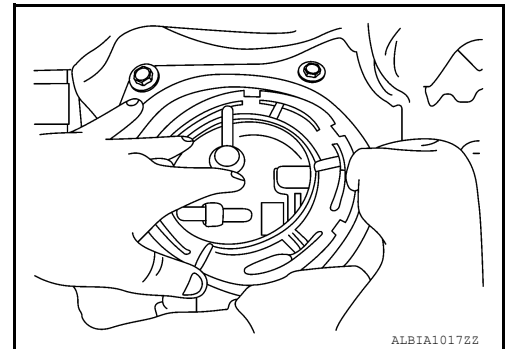

Tool number (A) : — (J-45747) (shown)
: KV101207S0 (—)

↩ : Front

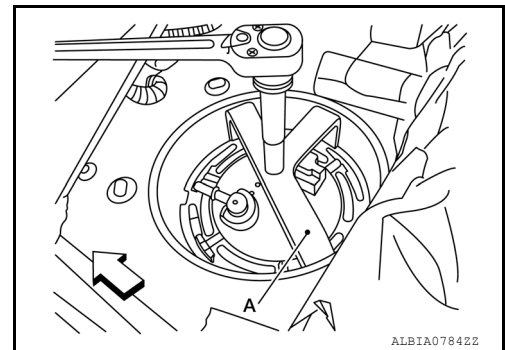

- j. Align the tabs (A) of the fuel level sensor, fuel filter, and fuel pump assembly to the matching marks (C) of the fuel tank for proper installation.

(B) : Retainer pawl

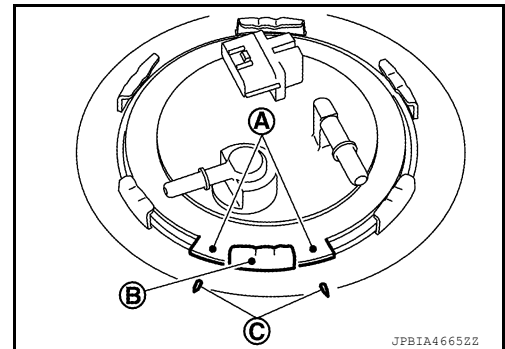

2. Reconnect the EVAP hose (2) and the fuel feed hose (1).

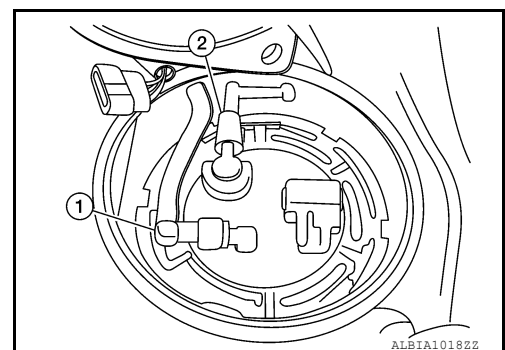

FUEL LEVEL SENSOR UNIT, FUEL FILTER AND FUEL PUMP ASSEMBLY

< REMOVAL AND INSTALLATION >

- Connect the quick connector as follows:
 - Check the connection for damage or any foreign materials.
 - Align the connector with the tube, then insert the connector straight into the tube until a click is heard.
- After the tube is connected, make sure the connection is secure by performing the following checks:
 - Pull the tube and the connector to make sure they are securely connected.

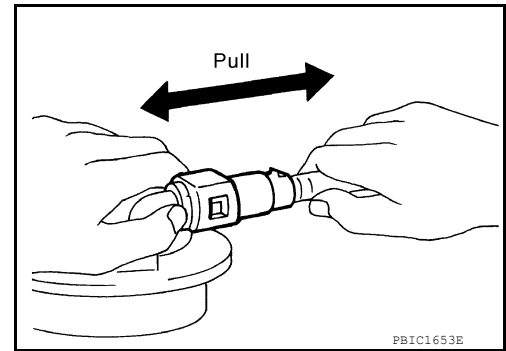

- Visually confirm that the two retainer tabs are connected to the quick connector.
- Installation of the remaining components in the reverse order of removal.

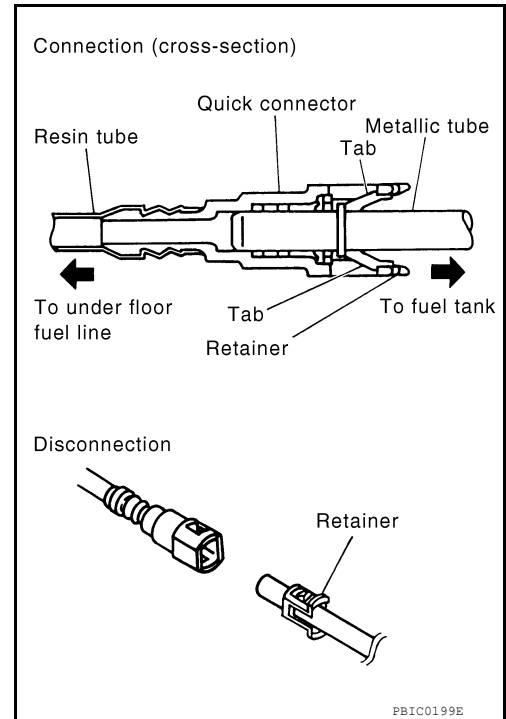

INSPECTION AFTER INSTALLATION

Use the following procedure to check for fuel leaks.

1. Turn the ignition switch to ON (without starting the engine) to apply fuel pressure to the fuel system, then check the connections for fuel leaks.
2. Start engine, raise idle, and verify there are no fuel leaks at the fuel system connections.

FUEL TANK

< REMOVAL AND INSTALLATION >

FUEL TANK

Exploded View

INFOID:000000011146244

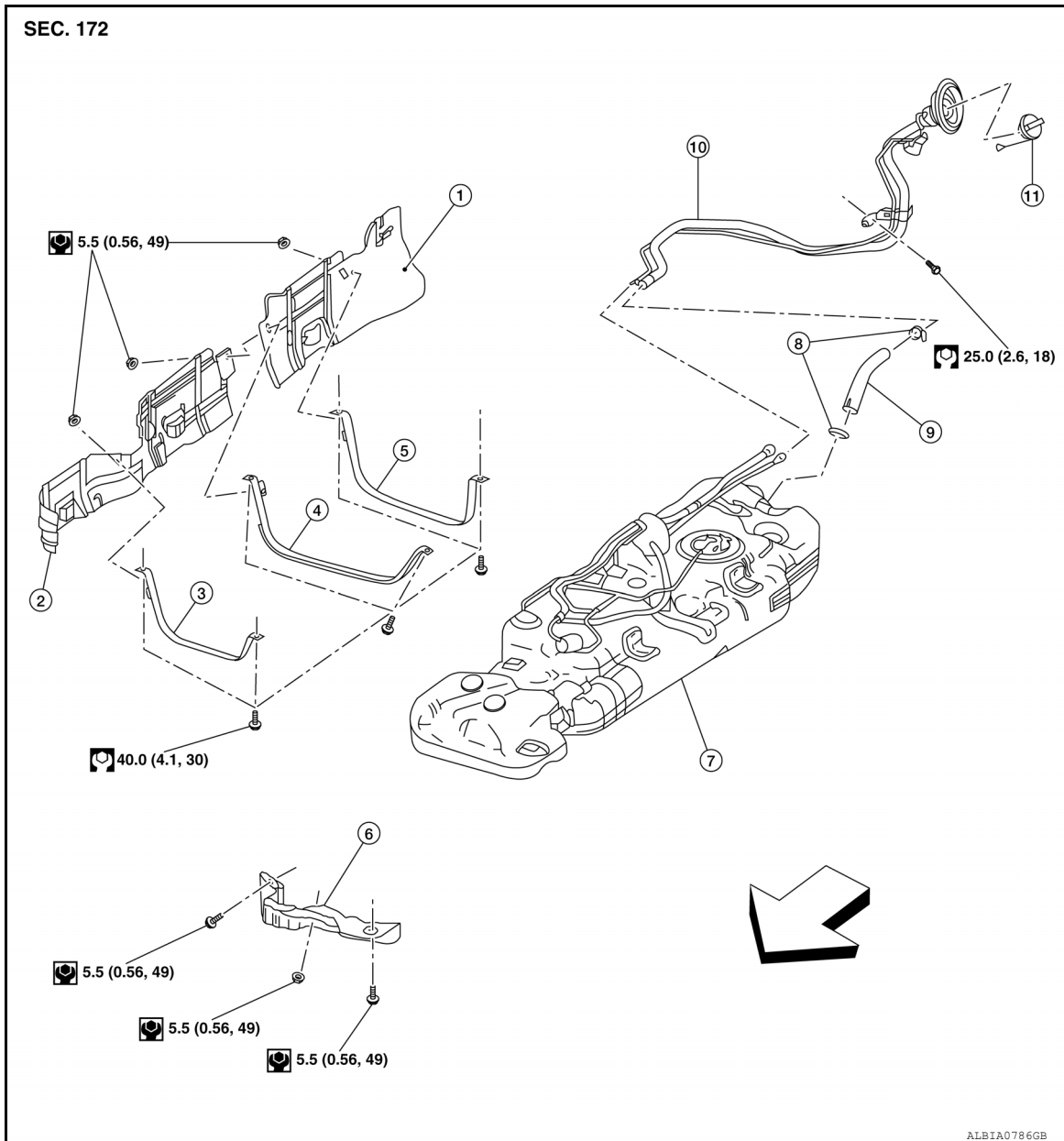

- | | | |
|-------------------------------|-------------------------------|-------------------------------|
| 1. Fuel tank protector 3 | 2. Fuel tank protector 2 | 3. Fuel tank mounting strap 1 |
| 4. Fuel tank mounting strap 2 | 5. Fuel tank mounting strap 3 | 6. Fuel tank protector 1 |
| 7. Fuel tank | 8. Clamp | 9. Fuel filler hose |
| 10. Fuel filler tube | 11. Fuel filler cap | ⇐ Front |

Removal and Installation

INFOID:000000011146245

WARNING:

Read "General Precautions" before working on the fuel system. Refer to [FL-2, "General Precaution"](#).

NOTE:

When removing components such as hoses, tubes/lines, etc., cap or plug openings to prevent fluid from spilling.

REMOVAL

FUEL TANK

< REMOVAL AND INSTALLATION >

1. Open the fuel filler cap to release the pressure inside the fuel tank.
2. Release fuel pressure from fuel line. Refer to [EC-176, "Work Procedure"](#) (For United States and Canada) or [EC-693, "Work Procedure"](#) (For Mexico).
3. Check the fuel level with the vehicle on a level surface. If the fuel gauge indicates more than the level as shown (1/2 full), drain the fuel from the fuel tank until the fuel gauge indicates a level at or below as shown (1/2 full).
 - In case the fuel pump does not operate, use the following procedure.
- a. Insert fuel tubing of less than 25mm (0.98in) diameter into the fuel filler tube through the fuel filler opening to drain fuel from the fuel filler tube.
- b. Disconnect the fuel filler hose from the fuel filler tube.
- c. Insert fuel tubing into the fuel tank through the fuel filler hose to drain fuel from the fuel tank.
 - As a guide, the fuel level reaches or is less than the level on the fuel gauge as shown, when approximately 37 ℓ (9-3/4 US gal, 8-1/8 Imp gal) of fuel is drained from a full fuel tank.
4. Disconnect the battery negative terminal. Refer to [PG-99, "Removal and Installation"](#).
5. Remove both second row (LH) bench seat front slide covers. Refer to [SE-123, "Exploded View"](#).
6. Position the second row (LH) bench seat to full forward position.
7. Remove both second row (LH) bench seat rear slide covers. Refer to [SE-123, "Exploded View"](#).
8. Position and secure the carpet to gain access to the fuel pump inspection hole cover.

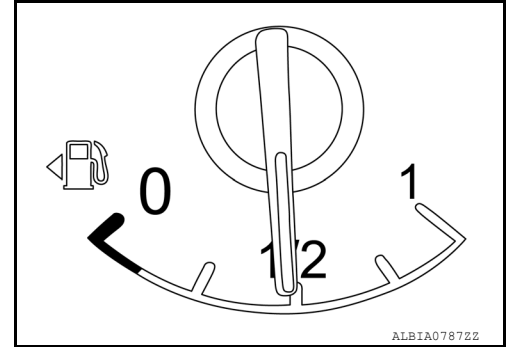

CAUTION:

Cover the immediate area surrounding the fuel pump inspection hole cover with plastic to avoid gasoline damage to the carpet.

9. Remove the center floor duct (LH). Refer to [VTL-13, "CENTER FLOOR DUCT : Removal and Installation - Center Floor Duct"](#).
10. Turn the four retainers (A) 90 degrees to disengage the clips and remove the fuel pump inspection hole cover.

↔ : Front

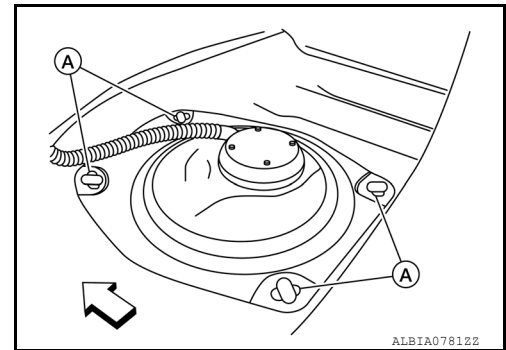

11. Disconnect the fuel level sensor, fuel filter, and fuel pump assembly harness connector (A), EVAP hose connector (C), and the fuel feed hose connector (B) from the fuel level sensor unit, fuel filter, and fuel pump assembly.

↔ : Front

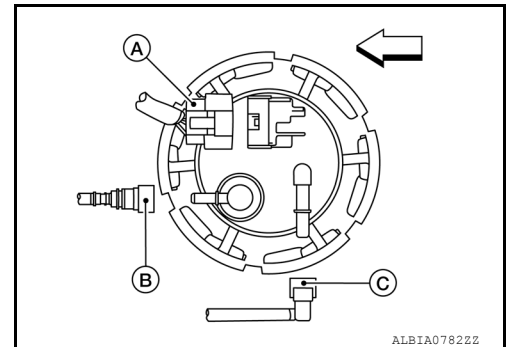

FUEL TANK

< REMOVAL AND INSTALLATION >

Disconnect the quick connector as follows:

- Hold the sides of the connector, push in tabs and pull out the tube.
- If the connector and the tube are stuck together, push and pull several times until they start to move. Then disconnect them by pulling.

CAUTION:

- The tube can be removed when the tabs are completely depressed. Do not twist it more than necessary.
- Do not use any tools to remove the quick connector.
- Keep the resin tube away from heat. Be especially careful when welding near the tube.
- Prevent acid liquid such as battery electrolyte, etc. from getting on the resin tube.
- Do not bend or twist the tube during installation and removal.
- Only when the tube is replaced, remove the remaining retainer on the tube or fuel level sensor, fuel filter, and fuel pump assembly.
- When the tube or fuel level sensor, fuel filter, and fuel pump assembly is replaced, also replace the retainer with a new one (green colored retainer).
- To keep the connecting portion clean and to avoid damage and foreign materials, cover them completely with plastic bags or something similar.

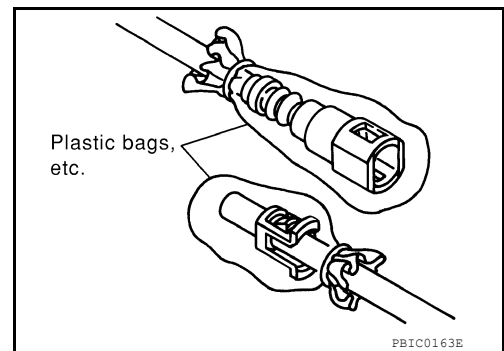
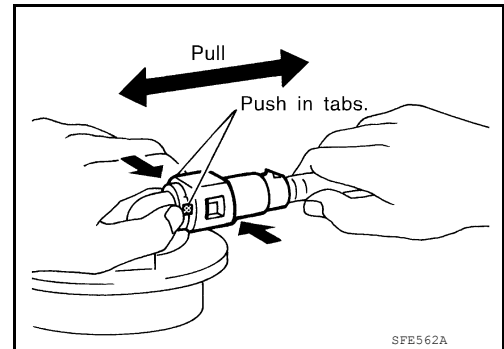

12. Remove fuel tank protector 1 from the front side of the fuel tank.
13. Remove the nut (A) and separate the rear park brake cable (LH) (1) from fuel tank protector 3.

⇐ : Front

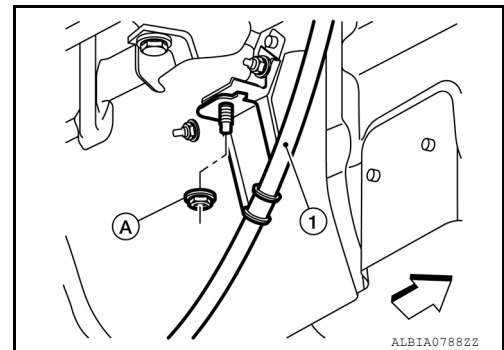

14. Remove the bolts and the outer reinforcement bar (if equipped).
15. Disconnect the fuel filler hose (A), the recirculation hose (B) and the EVAP tube (C).

⇐ : Front

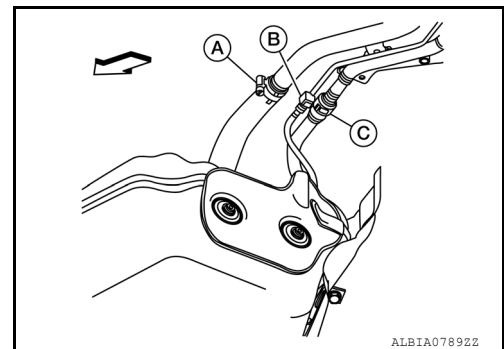

16. Support the center part of the fuel tank using a suitable jack.
17. Remove the fuel tank mounting strap bolts and mounting straps while supporting the fuel tank with a suitable jack.

NOTE:

The fuel tank, fuel tank mounting straps, fuel tank protector 2 and fuel tank protector 3 will be removed from the vehicle as an assembly.

18. Lower the suitable jack carefully to remove the fuel tank.

CAUTION:

Fuel tank may be in an unstable condition, due to the shape of the fuel tank bottom. Be sure to secure tank at all times.

A
FL
C
D
E
F
G
H
I
J
K
L
M
N
O
P

FUEL TANK

< REMOVAL AND INSTALLATION >

19. If replacing the fuel tank, remove the fuel level sensor unit, fuel filter and fuel pump assembly to transfer to the new fuel tank. Remove and discard the O-ring. Refer to [FL-6, "Removal and Installation"](#).

CAUTION:

Do not reuse O-ring.

INSTALLATION

Installation is in the reverse order of removal.

CAUTION:

Do not reuse O-ring.

- If fuel tank has been replaced, connect the transfer hose connector to the fuel level sensor, fuel filter, and fuel pump assembly. Inspect through the opening of the fuel tank and make sure that the transfer hose is routed as shown.

CAUTION:

- **Make sure that the transfer hose does not interfere with the float arm assembly.**
- **If the fuel level sensor unit, fuel filter and fuel pump assembly is removed refer to [INSTALLATION](#). Refer to [FL-6, "Removal and Installation"](#).**

← : Front

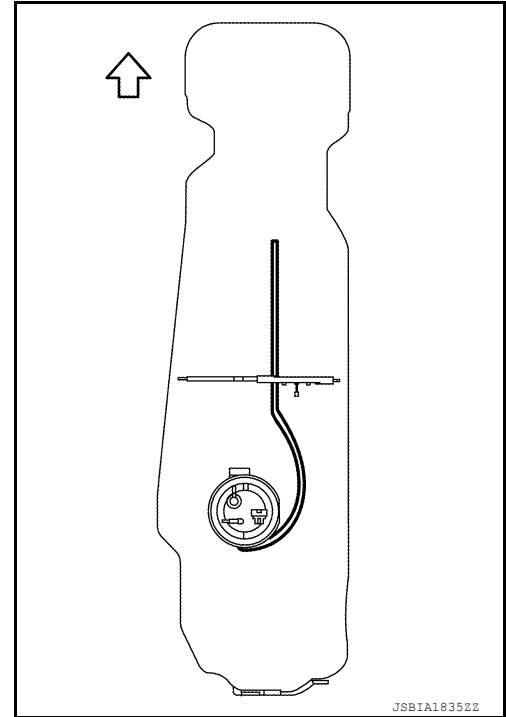

- If fuel tank has been replaced, align the tabs (A) of the fuel level sensor, fuel filter, and fuel pump assembly to the matching marks (C) of the fuel tank for proper installation.

(B) : Retainer pawl

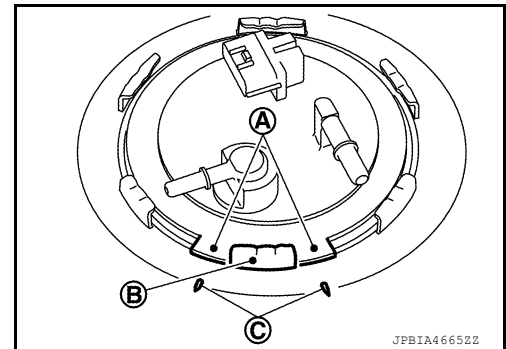

- Connect the quick connector as follows:
 - Check the connection for damage or any foreign materials.
 - Align the connector with the tube, then insert the connector straight into the tube until a click is heard.
- Before tightening the fuel tank mounting straps, temporarily install the filler hose and the recirculation hose. Tighten all fuel tank mounting strap bolts to specification, then tighten the hose clamps.
- After the tube is connected, make sure the connection is secure by performing the following checks:
 - Pull on the tube and the connector to make sure they are securely connected.

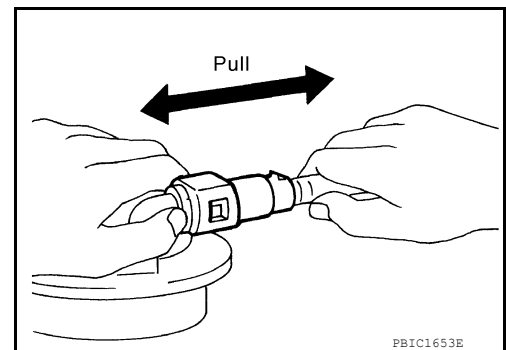

FUEL TANK

< REMOVAL AND INSTALLATION >

- Visually confirm that the two retainer tabs are connected to the quick connector.

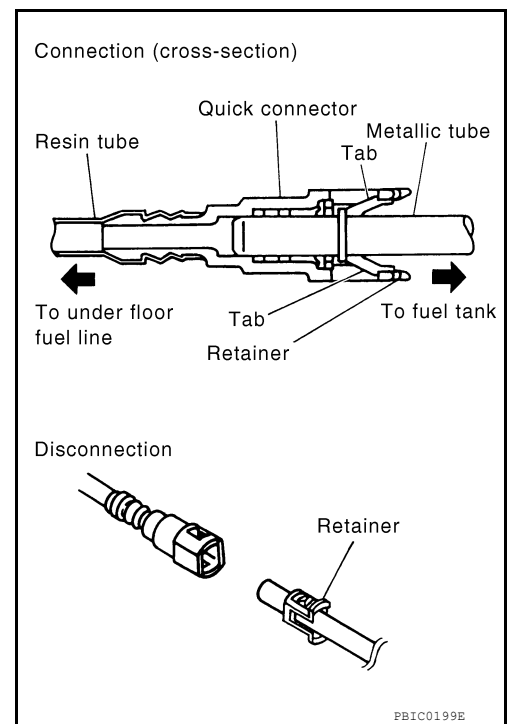

INSPECTION AFTER INSTALLATION

Use the following procedure to check for fuel leaks.

1. Turn the ignition switch ON (without starting the engine). Then check the connections for fuel leaks by applying fuel pressure to the fuel piping.
2. Start engine, raise idle and verify there are no leaks at the fuel system connections.

EVAP CANISTER

< REMOVAL AND INSTALLATION >

EVAP CANISTER

Exploded View

INFOID:000000011146246

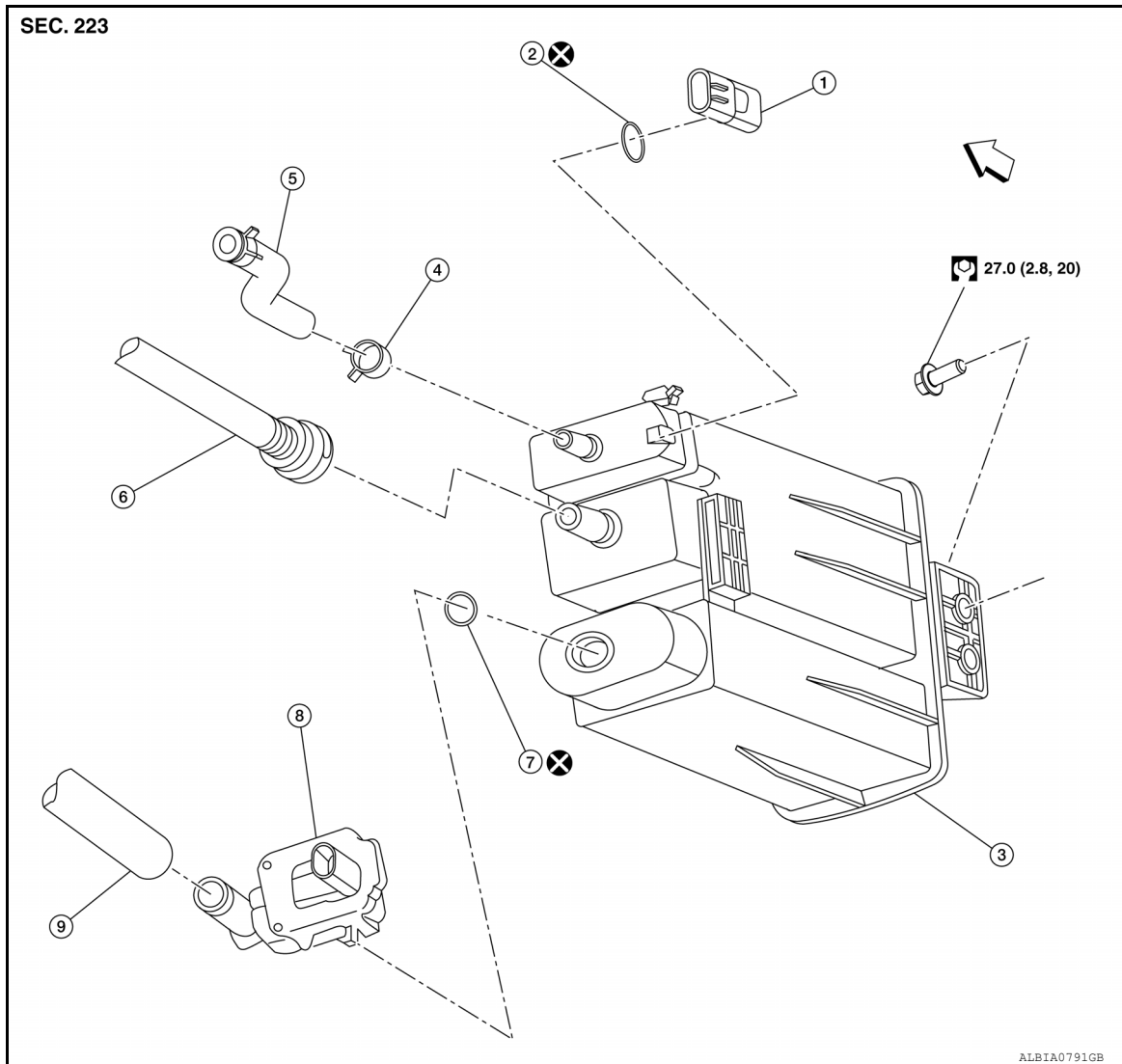

- | | | |
|--|-------------------------------------|--|
| 1. EVAP control system pressure sensor | 2. O-ring | 3. EVAP canister |
| 4. Hose clamp | 5. EVAP canister purge hose | 6. EVAP vent line |
| 7. O-ring | 8. EVAP canister vent control valve | 9. EVAP canister vent control valve hose |

⇐ Front

Removal and Installation

INFOID:000000011146247

NOTE:

The EVAP canister vent control valve and EVAP canister system pressure sensor can be removed without removing the EVAP canister.

REMOVAL

1. Disconnect the EVAP control system pressure sensor harness connector and the EVAP canister vent control valve harness connector.
2. Disconnect the EVAP canister purge hose, the EVAP vent line, and the EVAP canister vent control valve hose.
3. Remove the EVAP canister bolt.

EVAP CANISTER

< REMOVAL AND INSTALLATION >

4. Remove the EVAP canister from the vehicle.

INSTALLATION

Installation is in the reverse order of removal.

CAUTION:

During service requiring removal of O-rings, always replace each O-ring with a new one during installation.

Inspection

Check EVAP canister as follows:

1. Block port (A).
2. Blow air into port (B) and check that it flows freely out of port (C).
3. Release blocked port (A).
4. Apply vacuum pressure to port (A) and check that vacuum pressure exists at the ports (B) and (C).
5. Block port (B) and (A).
6. Apply pressure to port (C) and check that there is no leakage.

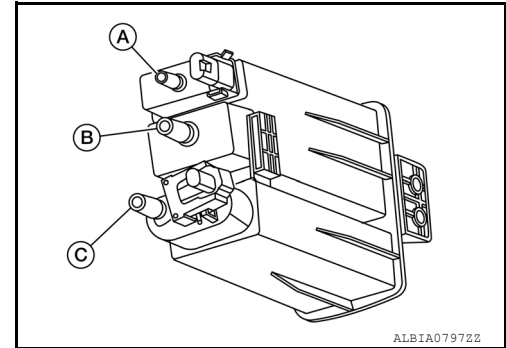

A

FL

C

D

E

F

G

H

I

J

K

L

M

N

O

P

EVAP CANISTER FILTER

< REMOVAL AND INSTALLATION >

EVAP CANISTER FILTER

Exploded View

INFOID:000000011146249

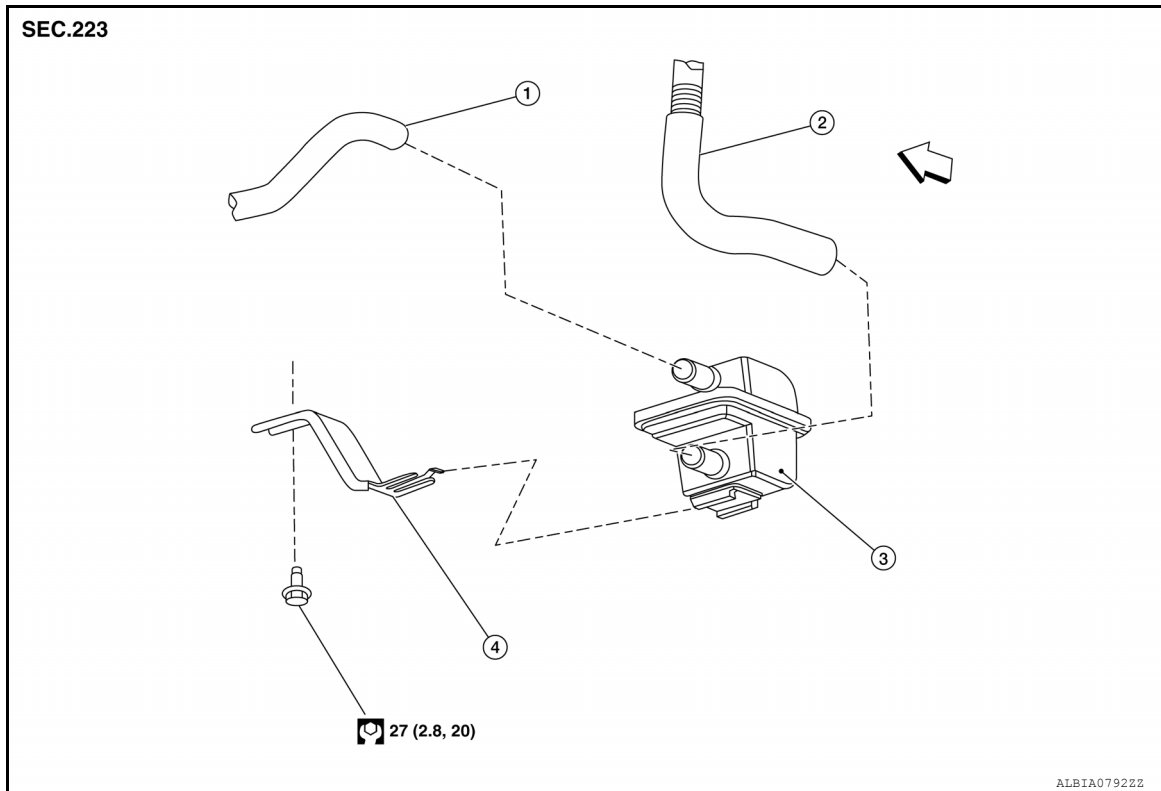

- 1. EVAP canister vent control valve hose
 - 2. Canister drain hose
 - 3. EVAP canister filter
 - 4. EVAP canister filter bracket
- ⇐ Front

Removal and Installation

INFOID:000000011146250

REMOVAL

1. Disconnect EVAP canister vent control valve hose from EVAP canister filter.
2. Disconnect canister drain hose from EVAP canister filter.
3. Remove the bolt and the EVAP canister filter.

INSTALLATION

Installation is in the reverse order of removal.

EVAP CANISTER VENT CONTROL VALVE

< REMOVAL AND INSTALLATION >

EVAP CANISTER VENT CONTROL VALVE

Exploded View

INFOID:000000011146251

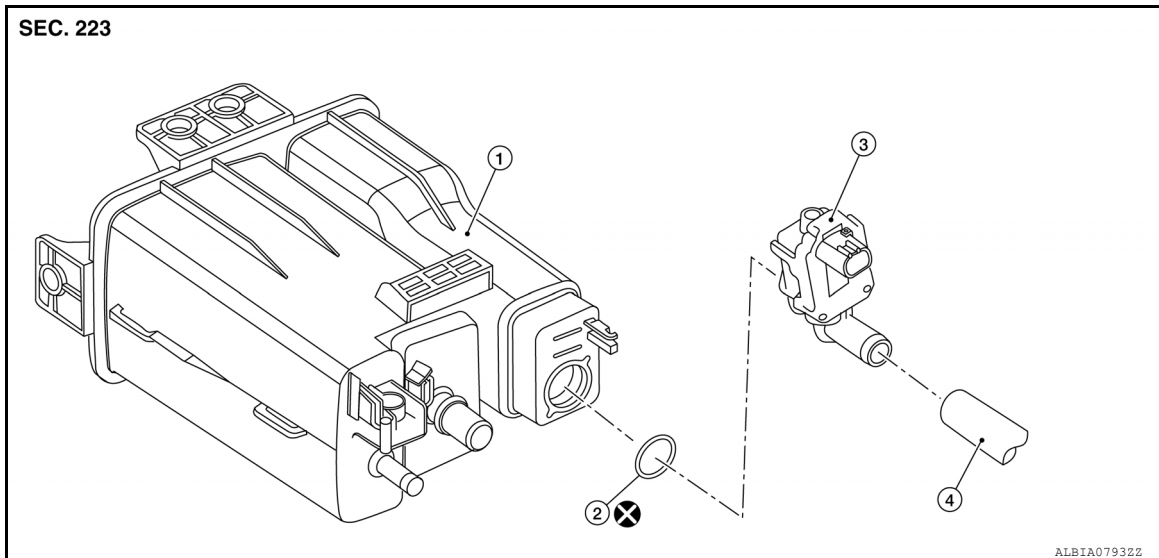

1. EVAP canister
2. O-ring
3. EVAP canister vent control valve
4. EVAP canister vent control valve hose

Removal and Installation

INFOID:000000011146252

NOTE:

The EVAP canister vent control valve can be removed without removing the EVAP canister.

REMOVAL

1. Disconnect EVAP canister vent control valve hose from EVAP canister vent control valve.
2. Disconnect EVAP canister vent control valve harness connector.
3. Turn EVAP canister vent control valve counterclockwise.

- (A) : Lock
(B) : Unlock

4. Remove the EVAP canister vent control valve and O-ring.

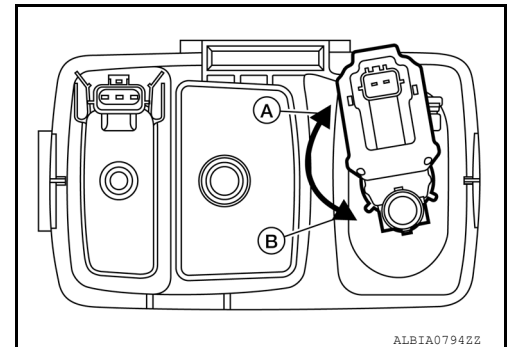

INSTALLATION

Installation is in the reverse order of removal.

CAUTION:

Do not reuse O-ring.

A
FL
C
D
E
F
G
H
I
J
K
L
M
N
O
P

EVAP CONTROL SYSTEM PRESSURE SENSOR

< REMOVAL AND INSTALLATION >

EVAP CONTROL SYSTEM PRESSURE SENSOR

Exploded View

INFOID:000000011146253

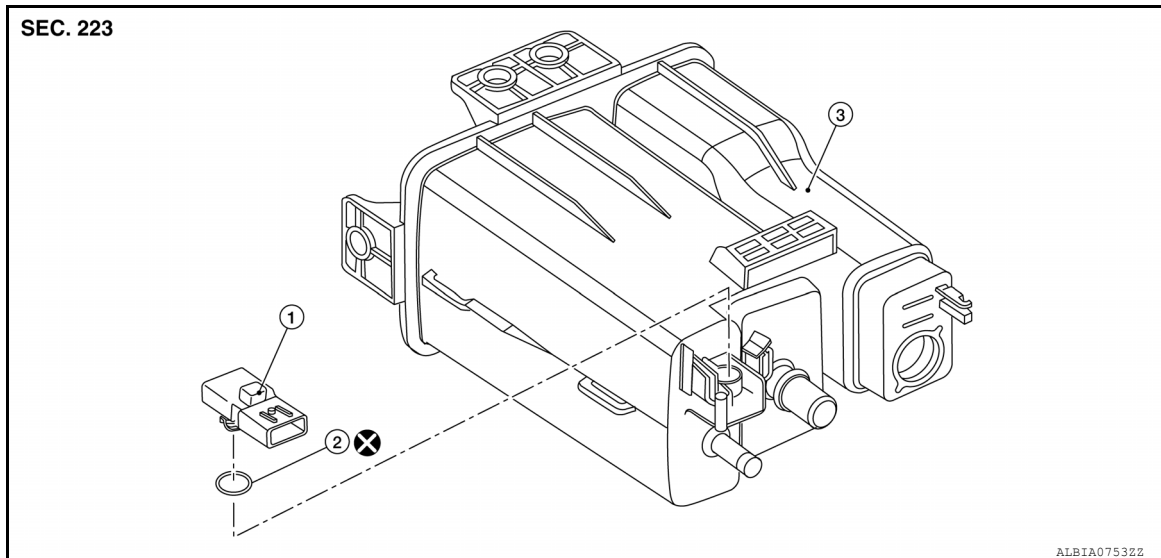

1. EVAP control system pressure sensor 2. O-ring 3. EVAP canister

Removal and Installation

INFOID:000000011146254

NOTE:

The EVAP canister system pressure sensor can be removed without removing the EVAP canister.

REMOVAL

1. Disconnect EVAP canister purge hose from EVAP canister.
2. Disconnect EVAP control system pressure sensor.
3. Remove EVAP control system pressure sensor and O-ring.

INSTALLATION

Installation is in the reverse order of removal.

CAUTION:

Do not reuse O-ring.

FUEL LEVEL SENSOR UNIT

< DISASSEMBLY AND ASSEMBLY >

DISASSEMBLY AND ASSEMBLY

FUEL LEVEL SENSOR UNIT

Disassembly and Assembly

INFOID:000000011146255

A

FL

Fuel Level Sensor Unit

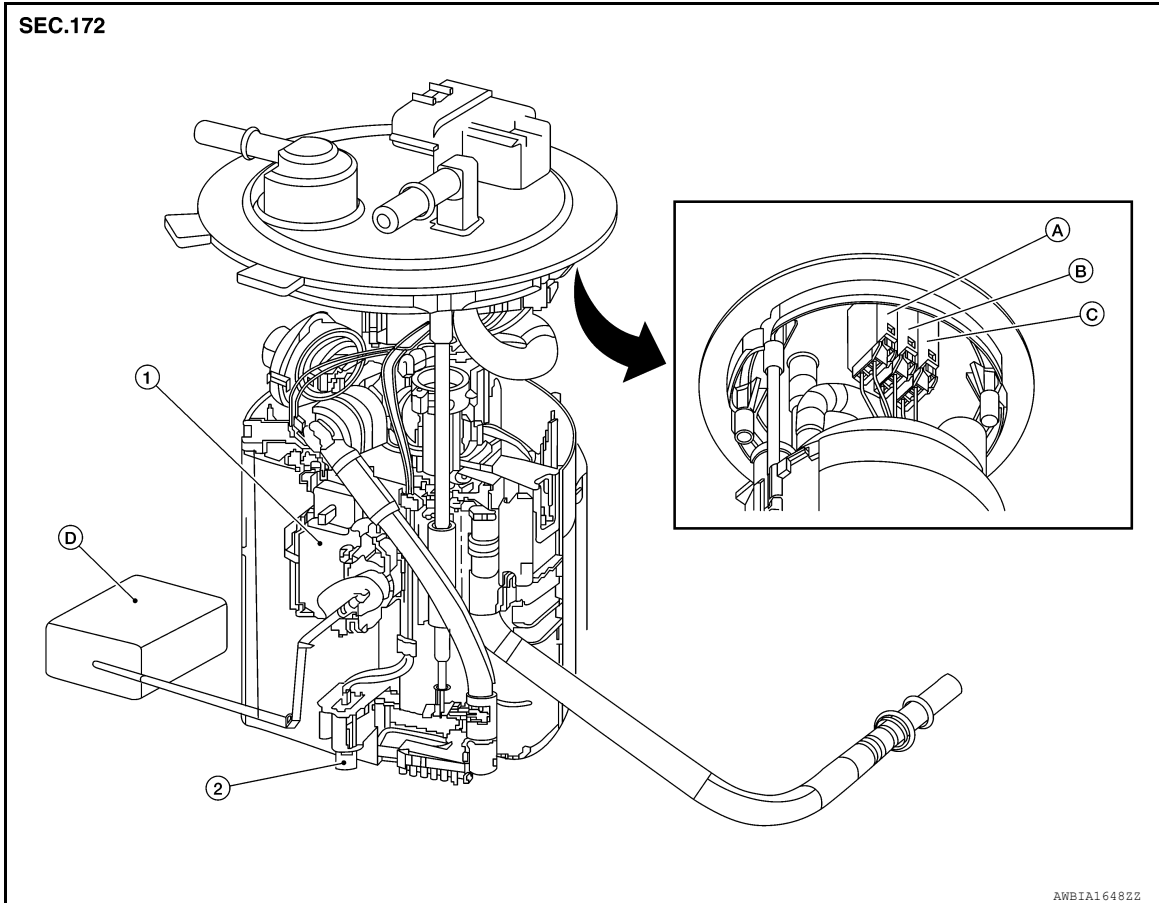

C

D

E

F

G

H

I

J

K

L

M

N

O

P

- | | | |
|--------------------------------|---|---|
| 1. Fuel level sensor unit | 2. Fuel tank temperature sensor | A. Fuel level sensor unit harness connector |
| B. Fuel pump harness connector | C. Fuel tank temperature sensor harness connector | D. Float arm assembly connector |

Disassembly

NOTE:

Before disassembly, note the proper placement of the wires to the correct terminals and correct wire routing to the terminals.

1. Disconnect the fuel level sensor unit (A) and the fuel tank temperature sensor (C) harness connectors. Press the tabs on the terminals to release the locking tabs.

(B) : Fuel pump harness connector

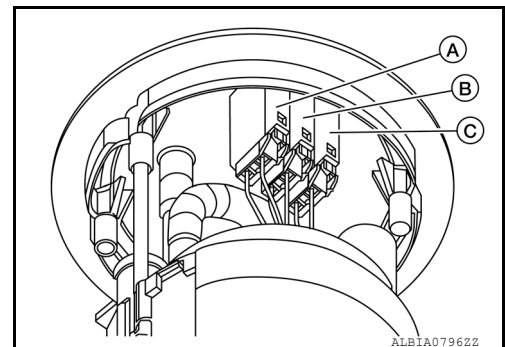

FUEL LEVEL SENSOR UNIT

< DISASSEMBLY AND ASSEMBLY >

2. Release the two clips and remove the fuel tank temperature sensor from the pump assembly.

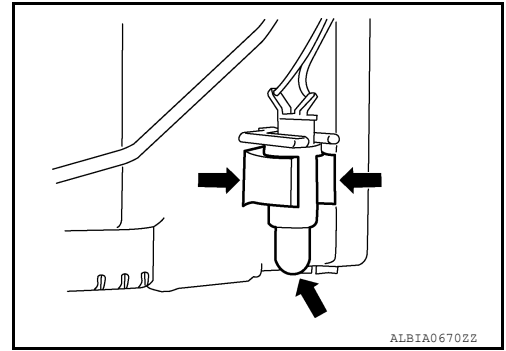

3. Release the tab (A) and slide the fuel level sensor unit and float arm assembly (B) up to remove.

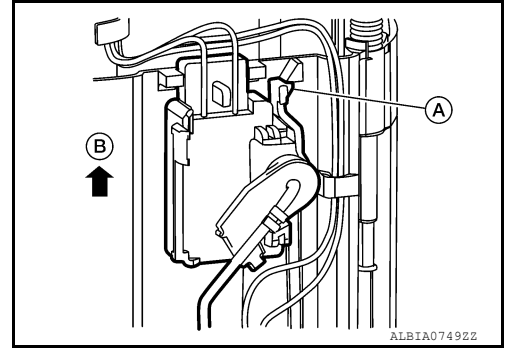

Assembly

Assembly is the reverse order of disassembly.

NOTE:

- Ensure proper placement of the wires to the correct terminals and correct wire routing to the terminals.
- After connecting terminals, ensure they are securely locked and can not be pulled out.
- When installing the fuel level sensor unit, push down until the tab is locked into place.

SERVICE DATA AND SPECIFICATIONS (SDS)

< SERVICE DATA AND SPECIFICATIONS (SDS)

SERVICE DATA AND SPECIFICATIONS (SDS)

SERVICE DATA AND SPECIFICATIONS (SDS)

Fuel Tank

INFOID:0000000011146256

A

FL

Standard and Limit

Fuel tank capacity	Approx. 74.0 ℓ (19-1/2 US gal, 16-1/4 Imp gal)
Fuel recommendation	Refer to MA-15. "FOR USA AND CANADA : Fluids and Lubricants" (United States and Canada) or MA-16. "FOR MEXICO : Fluids and Lubricants" (Mexico).

C

D

E

F

G

H

I

J

K

L

M

N

O

P