

SECTION **HAC**

HEATER & AIR CONDITIONING CONTROL SYSTEM

CONTENTS

AUTOMATIC AIR CONDITIONING	SYSTEM	19	F
PRECAUTION	FRONT AUTOMATIC AIR CONDITIONING SYSTEM	19	G
PRECAUTIONS	FRONT AUTOMATIC AIR CONDITIONING SYSTEM : System Diagram	19	H
Precaution for Supplemental Restraint System (SRS) "AIR BAG" and "SEAT BELT PRE-TENSIONER"	FRONT AUTOMATIC AIR CONDITIONING SYSTEM : System Description	19	H
Precautions For Refrigerant System Service	FRONT AUTOMATIC AIR CONDITIONING SYSTEM : Air Flow Control	20	HAC
Precaution for Service Equipment	FRONT AUTOMATIC AIR CONDITIONING SYSTEM : Air Inlet Control	21	
Precaution for Work	FRONT AUTOMATIC AIR CONDITIONING SYSTEM : Air Outlet Control	22	J
PREPARATION	FRONT AUTOMATIC AIR CONDITIONING SYSTEM : Compressor Control	22	K
PREPARATION	FRONT AUTOMATIC AIR CONDITIONING SYSTEM : Door Control	23	L
Special Service Tool	FRONT AUTOMATIC AIR CONDITIONING SYSTEM : Temperature Control	25	
Commercial Service Tool	FRONT AUTOMATIC AIR CONDITIONING SYSTEM : Fail-safe	25	M
SYSTEM DESCRIPTION	REAR AUTOMATIC AIR CONDITIONING SYSTEM	25	N
COMPONENT PARTS	REAR AUTOMATIC AIR CONDITIONING SYSTEM : System Diagram	26	O
FRONT AUTOMATIC AIR CONDITIONING SYSTEM	REAR AUTOMATIC AIR CONDITIONING SYSTEM : System Description	26	P
FRONT AUTOMATIC AIR CONDITIONING SYSTEM : Component Parts Location	REAR AUTOMATIC AIR CONDITIONING SYSTEM : Air Flow Control	27	
FRONT AUTOMATIC AIR CONDITIONING SYSTEM : Component Description	REAR AUTOMATIC AIR CONDITIONING SYSTEM : Air Outlet Control	28	
REAR AUTOMATIC AIR CONDITIONING SYSTEM	REAR AUTOMATIC AIR CONDITIONING SYSTEM : Door Control	29	
REAR AUTOMATIC AIR CONDITIONING SYSTEM : Component Parts Location	REAR AUTOMATIC AIR CONDITIONING SYSTEM : Temperature Control	30	
REAR AUTOMATIC AIR CONDITIONING SYSTEM : Component Description	ACCS (ADVANCED CLIMATE CONTROL SYSTEM)	30	
ACCS (ADVANCED CLIMATE CONTROL SYSTEM)	ACCS (ADVANCED CLIMATE CONTROL SYSTEM) : Component Parts Location	17	
ACCS (ADVANCED CLIMATE CONTROL SYSTEM) : Component Parts Location	ACCS (ADVANCED CLIMATE CONTROL SYSTEM) : Component Description	18	
ACCS (ADVANCED CLIMATE CONTROL SYSTEM) : Component Description			

ACCS (ADVANCED CLIMATE CONTROL SYSTEM) : System Diagram	31	ACCS (ADVANCED CLIMATE CONTROL SYSTEM)	81
ACCS (ADVANCED CLIMATE CONTROL SYSTEM) : System Description	31	ACCS (ADVANCED CLIMATE CONTROL SYSTEM) : Work Procedure	81
ACCS (ADVANCED CLIMATE CONTROL SYSTEM) : Automatic Intake Control (Exhaust Gas / Outside Odor Detecting Mechanism)	31	SYSTEM SETTING	82
ACCS (ADVANCED CLIMATE CONTROL SYSTEM) : Plasmacluster Control	32	FRONT AUTOMATIC AIR CONDITIONING SYSTEM	82
OPERATION	33	FRONT AUTOMATIC AIR CONDITIONING SYSTEM : Temperature Setting Trimmer (Front)	82
FRONT AUTOMATIC AIR CONDITIONING SYSTEM	33	FRONT AUTOMATIC AIR CONDITIONING SYSTEM : Foot Position Setting Trimmer	82
FRONT AUTOMATIC AIR CONDITIONING SYSTEM : Switch Name and Function	33	FRONT AUTOMATIC AIR CONDITIONING SYSTEM : Inlet Port Memory Function (FRE)	83
REAR AUTOMATIC AIR CONDITIONING SYSTEM	35	FRONT AUTOMATIC AIR CONDITIONING SYSTEM : Inlet Port Memory Function (REC)	83
REAR AUTOMATIC AIR CONDITIONING SYSTEM : Switch Name and Function	35	REAR AUTOMATIC AIR CONDITIONING SYSTEM	83
ACCS (ADVANCED CLIMATE CONTROL SYSTEM)	37	REAR AUTOMATIC AIR CONDITIONING SYSTEM : Temperature Setting Trimmer (Rear)	83
ACCS (ADVANCED CLIMATE CONTROL SYSTEM) : Switch Name and Function	37	ACCS (ADVANCED CLIMATE CONTROL SYSTEM)	84
DIAGNOSIS SYSTEM (HVAC)	40	ACCS (ADVANCED CLIMATE CONTROL SYSTEM) : Exhaust Gas / Outside Odor Detecting Sensor Sensitivity Adjustment Function	84
Description	40	ACCS (ADVANCED CLIMATE CONTROL SYSTEM) : Auto Intake Switch Interlocking Movement Change Function	84
CONSULT Function	40	DTC/CIRCUIT DIAGNOSIS	86
ECU DIAGNOSIS INFORMATION	44	U1000 CAN COMM CIRCUIT	86
A/C AUTO AMP.	44	Description	86
Reference Value	44	DTC Logic	86
Fail-safe	48	Diagnosis Procedure	86
DTC Index	48	U1010 CONTROL UNIT (CAN)	87
ECM, IPDM E/R, BCM	50	Description	87
List of ECU Reference	50	DTC Logic	87
WIRING DIAGRAM	51	Diagnosis Procedure	87
AUTOMATIC AIR CONDITIONING SYSTEM ...	51	B2578, B2579 IN-VEHICLE SENSOR	88
Wiring Diagram	51	DTC Logic	88
BASIC INSPECTION	74	Diagnosis Procedure	88
DIAGNOSIS AND REPAIR WORK FLOW	74	Component Inspection	89
Work Flow	74	B257B, B257C AMBIENT SENSOR	91
OPERATION INSPECTION	77	DTC Logic	91
FRONT AUTOMATIC AIR CONDITIONING SYSTEM	77	Diagnosis Procedure	91
FRONT AUTOMATIC AIR CONDITIONING SYSTEM : Work Procedure	77	Component Inspection	92
REAR AUTOMATIC AIR CONDITIONING SYSTEM	78	B2581, B2582 INTAKE SENSOR	94
REAR AUTOMATIC AIR CONDITIONING SYSTEM : Work Procedure	78	DTC Logic	94
		Diagnosis Procedure	94
		Component Inspection	95

B262A, B262B, B2657, B2658 EXHAUST GAS/OUTSIDE ODOR DETECTING SENSOR		
97	
DTC Logic	97	
Diagnosis Procedure	97	
B2630, B2631 SUNLOAD SENSOR	100	
DTC Logic	100	
Diagnosis Procedure	100	
Component Inspection	101	
B2632, B2633 AIR MIX DOOR MOTOR (DRIVER SIDE)	103	
DTC Logic	103	
Diagnosis Procedure	103	
B2634, B2635 AIR MIX DOOR MOTOR (PASSENGER SIDE)	105	
DTC Logic	105	
Diagnosis Procedure	105	
B2636, B2637, B2638, B2639, B2654 MODE DOOR MOTOR (FRONT)	107	
DTC Logic	107	
Diagnosis Procedure	107	
B263D, B263E, B263F INTAKE DOOR MOTOR	109	
DTC Logic	109	
Diagnosis Procedure	109	
B2799, B279A AIR MIX DOOR MOTOR (REAR)	111	
DTC Logic	111	
Diagnosis Procedure	111	
B279B, B279C MODE DOOR MOTOR (REAR)	113	
DTC Logic	113	
Diagnosis Procedure	113	
B279D, B279E REAR SHUT-OFF DOOR MOTOR	115	
DTC Logic	115	
Diagnosis Procedure	115	
B2796, B2797, B2798 COMMUNICATION ERROR	117	
DTC Logic	117	
Diagnosis Procedure	117	
B27B0 A/C AUTO AMP.	119	
DTC Logic	119	
Diagnosis Procedure	119	
POWER SUPPLY AND GROUND CIRCUIT	120	
A/C AUTO AMP.	120	
A/C AUTO AMP. : Diagnosis Procedure	120	
AIR MIX DOOR MOTOR (DRIVER SIDE)	120	
AIR MIX DOOR MOTOR (DRIVER SIDE) : Diagnosis Procedure	120	A
AIR MIX DOOR MOTOR (PASSENGER SIDE)	121	
AIR MIX DOOR MOTOR (PASSENGER SIDE) : Diagnosis Procedure	121	B
AIR MIX DOOR MOTOR (REAR)	122	
AIR MIX DOOR MOTOR (REAR) : Diagnosis Procedure	122	C
MODE DOOR MOTOR (FRONT)	123	
MODE DOOR MOTOR (FRONT) : Diagnosis Procedure	123	D
MODE DOOR MOTOR (REAR)	124	
MODE DOOR MOTOR (REAR) : Diagnosis Procedure	124	E
INTAKE DOOR MOTOR	125	
INTAKE DOOR MOTOR : Diagnosis Procedure ..	125	F
REAR SHUT-OFF DOOR MOTOR	126	
REAR SHUT-OFF DOOR MOTOR : Diagnosis Procedure	126	G
REAR A/C CONTROL	127	
REAR A/C CONTROL : Diagnosis Procedure	127	H
DOOR MOTOR	129	
Diagnosis Procedure	129	HAC
DOOR MOTOR COMMUNICATION CIRCUIT	131	
Diagnosis Procedure	131	J
FRONT BLOWER MOTOR	133	
Diagnosis Procedure	133	
Component Inspection (Front Blower Motor)	134	K
Component Inspection (Front Blower Motor Relay)	134	
IONIZER	136	
Component Function Check	136	L
Diagnosis Procedure	136	
MAGNET CLUTCH	138	
Component Function Check	138	M
Diagnosis Procedure	138	
PTC HEATER RELAY	139	
Description	139	
Component Function Check	139	O
Diagnosis Procedure	139	
Component Inspection	140	
PTC HEATER	141	
Diagnosis Procedure	141	P
REAR BLOWER MOTOR	143	
Diagnosis Procedure	143	
Component Inspection (Rear Blower Motor)	147	
Component Inspection (Rear Blower Motor Relay) ..	147	

Component Inspection (Rear Blower Motor Resistor)	147	Removal and Installation	161
SYMPTOM DIAGNOSIS	149	AMBIENT SENSOR	162
FRONT AUTOMATIC AIR CONDITIONING SYSTEM	149	Removal and Installation	162
Diagnosis Chart By Symptom	149	IN-VEHICLE SENSOR	163
REAR AUTOMATIC AIR CONDITIONING SYSTEM	151	Removal and Installation	163
Diagnosis Chart By Symptom	151	SUNLOAD SENSOR	164
ACCS (ADVANCED CLIMATE CONTROL SYSTEM)	152	Removal and Installation	164
Symptom Table	152	INTAKE SENSOR	165
INSUFFICIENT COOLING	153	Removal and Installation	165
FRONT AIR CONDITIONER	153	EXHAUST GAS/OUTSIDE ODOR DETECTING SENSOR	166
FRONT AIR CONDITIONER : Description	153	Removal and Installation	166
FRONT AIR CONDITIONER : Diagnosis Procedure	153	REFRIGERANT PRESSURE SENSOR	167
REAR AIR CONDITIONER	154	Removal and Installation	167
REAR AIR CONDITIONER : Description	154	DOOR MOTOR	168
REAR AIR CONDITIONER : Diagnosis Procedure	154	Exploded View	168
INSUFFICIENT HEATING	155	MODE DOOR MOTOR	169
FRONT AIR CONDITIONER	155	MODE DOOR MOTOR : Removal and Installation	
FRONT AIR CONDITIONER : Description	155	- Mode Door Motor (Front)	169
FRONT AIR CONDITIONER : Diagnosis Procedure	155	MODE DOOR MOTOR : Removal and Installation	
REAR AIR CONDITIONER	155	- Mode Door Motor (Rear)	169
REAR AIR CONDITIONER : Description	156	AIR MIX DOOR MOTOR	169
REAR AIR CONDITIONER : Diagnosis Procedure	156	AIR MIX DOOR MOTOR : Removal and Installation	
COMPRESSOR DOES NOT OPERATE	157	- Air Mix Door Motor (Driver Side)	170
Description	157	AIR MIX DOOR MOTOR : Removal and Installation	
Diagnosis Procedure	157	- Air Mix Door Motor (Passenger Side)	170
REMOVAL AND INSTALLATION	159	AIR MIX DOOR MOTOR : Removal and Installation	
A/C AND AV SWITCH ASSEMBLY	159	- Air Mix Door Motor (Rear)	170
Removal and Installation	159	INTAKE DOOR MOTOR	170
REAR AIR CONTROL	160	INTAKE DOOR MOTOR : Removal and Installation	
Removal and Installation	160	170
A/C AUTO AMP.	161	REAR SHUT-OFF DOOR MOTOR	170
Exploded View	161	REAR SHUT-OFF DOOR MOTOR : Removal and Installation	
		170
		BLOWER MOTOR RESISTOR	171
		Removal and Installation - Rear Blower Motor Resistor 1	171
		Removal and Installation - Rear Blower Motor Resistor 2	171
		IONIZER	172
		Exploded View	172
		Removal and Installation	172

PRECAUTION

PRECAUTIONS

Precaution for Supplemental Restraint System (SRS) "AIR BAG" and "SEAT BELT PRE-TENSIONER"

INFOID:000000011136075

The Supplemental Restraint System such as "AIR BAG" and "SEAT BELT PRE-TENSIONER", used along with a front seat belt, helps to reduce the risk or severity of injury to the driver and front passenger for certain types of collision. This system includes dual stage front air bag modules. The SRS system may only deploy one front air bag, depending on the severity of a collision and whether the front passenger seat is occupied. Information necessary to service the system safely is included in the SR and SB section of this Service Manual.

WARNING:

- To avoid rendering the SRS inoperative, which could increase the risk of personal injury or death in the event of a collision which would result in air bag inflation, all maintenance must be performed by an authorized NISSAN/INFINITI dealer.
- Improper maintenance, including incorrect removal and installation of the SRS, can lead to personal injury caused by unintentional activation of the system. For removal of Spiral Cable and Air Bag Module, see the SR section.
- Do not use electrical test equipment on any circuit related to the SRS unless instructed to in this Service Manual. SRS wiring harnesses can be identified by yellow and/or orange harnesses or harness connectors.

PRECAUTIONS WHEN USING POWER TOOLS (AIR OR ELECTRIC) AND HAMMERS

WARNING:

- When working near the Airbag Diagnosis Sensor Unit or other Airbag System sensors with the Ignition ON or engine running, DO NOT use air or electric power tools or strike near the sensor(s) with a hammer. Heavy vibration could activate the sensor(s) and deploy the air bag(s), possibly causing serious injury.
- When using air or electric power tools or hammers, always switch the Ignition OFF, disconnect the battery and wait at least three minutes before performing any service.

Precautions For Refrigerant System Service

INFOID:000000011136076

WORKING WITH HFC-134a (R-134a)

CAUTION:

- CFC-12 (R-12) refrigerant and HFC-134a (R-134a) refrigerant are not compatible. Compressor malfunction is likely to occur if the refrigerants are mixed, refer to "CONTAMINATED REFRIGERANT" below. To determine the purity of HFC-134a (R-134a) in the vehicle and recovery tank, use Refrigerant recovery/recycling recharging equipment and Refrigerant Identifier.
- Use only specified oil for the HFC-134a (R-134a) A/C system and HFC-134a (R-134a) components. Compressor malfunction is likely to occur if oil other than that specified is used.
- The specified HFC-134a (R-134a) oil rapidly absorbs moisture from the atmosphere. The following handling precautions must be observed:
 - Cap (seal) the component immediately to minimize the entry of moisture from the atmosphere when removing refrigerant components from a vehicle.
 - Do not remove the caps (unseal) until just before connecting the components when installing refrigerant components to a vehicle. Connect all refrigerant loop components as quickly as possible to minimize the entry of moisture into system.
 - Use only the specified oil from a sealed container. Reseal containers of oil immediately. Oil becomes moisture saturated and should not be used without proper sealing.
 - Do not allow oil to come in contact with styrene foam parts. Damage may result.

GENERAL REFRIGERANT PRECAUTION

WARNING:

- Do not breathe A/C refrigerant and oil vapor or mist. Exposure may irritate eyes, nose and throat. Remove HFC-134a (R-134a) from the A/C system, using certified service equipment meeting requirements of SAE J-2210 [HFC-134a (R-134a) recycling equipment] or J-2209 [HFC-134a (R-134a) recov-

A
B
C
D
E
F
G
H
HAC
J
K
L
M
N
O
P

PRECAUTIONS

< PRECAUTION >

[AUTOMATIC AIR CONDITIONING]

- ery equipment]. Ventilate work area before resuming service if accidental system discharge occurs. Additional health and safety information may be obtained from refrigerant and oil manufacturers.
- Do not release refrigerant into the air. Use approved recovery/recycling/recharging equipment to capture the refrigerant each time an air conditioning system is discharged.
 - Always wear eye and hand protection (goggles and gloves) when working with any refrigerant or air conditioning system.
 - Do not store or heat refrigerant containers above 52°C (126°F).
 - Do not heat a refrigerant container with an open flame; Place the bottom of the container in a warm pail of water if container warming is required.
 - Do not intentionally drop, puncture or incinerate refrigerant containers.
 - Keep refrigerant away from open flames; poisonous gas is produced if refrigerant burns.
 - Refrigerant displaces oxygen; therefore be certain to work in well ventilated areas to prevent suffocation.
 - Do not pressure test or leak test HFC-134a (R-134a) service equipment and/or vehicle air conditioning systems with compressed air during repair. Some mixtures of air and HFC-134a (R-134a) have been shown to be combustible at elevated pressures. These mixtures, if ignited, may cause injury or property damage. Additional health and safety information may be obtained from refrigerant manufacturers.

O-RING AND REFRIGERANT CONNECTION

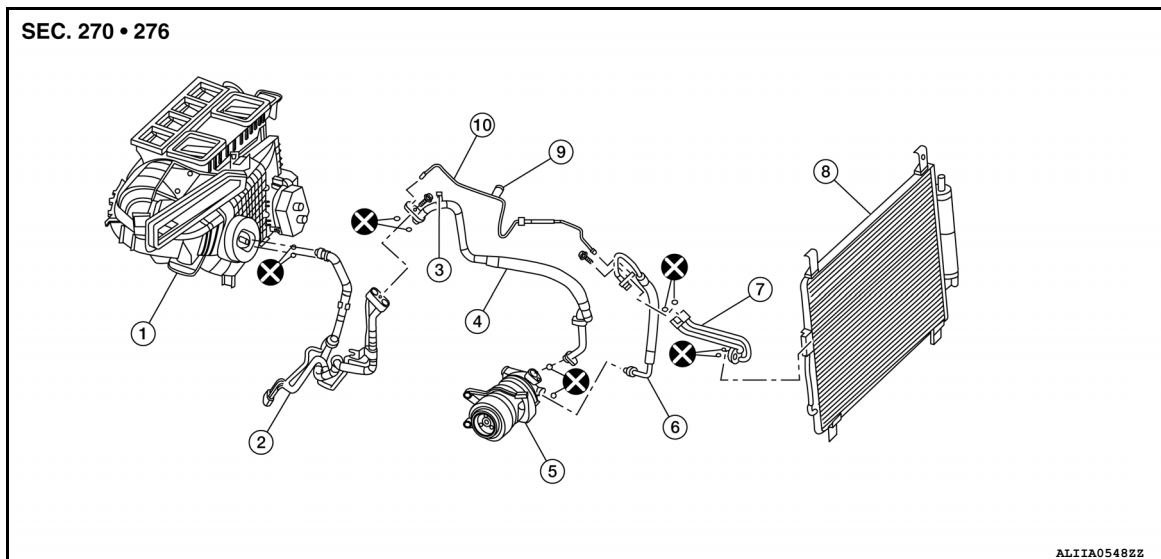

- | | | |
|--|--|--------------------------------|
| 1. Front heating and cooling unit assembly | 2. High-pressure and low-pressure pipe | 3. Low-pressure service port |
| 4. Low-pressure flexible hose | 5. Compressor | 6. High-pressure flexible hose |
| 7. Condenser pipe assembly | 8. Condenser (includes liquid tank) | 9. High-pressure service port |
| 10. High-pressure pipe | | |

A new type of refrigerant connection has been introduced to all refrigerant lines except the following locations:

- Expansion valve to evaporator
- Refrigerant pressure sensor to liquid tank

WARNING:

Check that all refrigerant is discharged into the recycling equipment and the pressure in the system is less than atmospheric pressure. Then gradually loosen the discharge side hose fitting and remove it.

CAUTION:

Observe the following when replacing or cleaning refrigerant cycle components.

- Store it in the same way as it is when mounted on the vehicle when the compressor is removed. Failure to do so will cause oil to enter the low-pressure chamber.
- Always use a torque wrench and a back-up wrench when connecting tubes.
- Immediately plug all openings to prevent entry of dust and moisture after disconnecting tubes.
- Connect the pipes at the final stage of the operation when installing an air conditioner in the vehicle. Do not remove the seal caps of pipes and other components until just before required for connection.

PRECAUTIONS

[AUTOMATIC AIR CONDITIONING]

< PRECAUTION >

- Allow components stored in cool areas to warm to working area temperature before removing seal caps. This prevents condensation from forming inside A/C components.
- Remove moisture thoroughly from the refrigeration system before charging the refrigerant.
- Do not reuse O-rings.
- Apply oil to circle of the O-rings shown in illustration when connecting tube. Be careful not to apply oil to threaded portion.
- O-ring must be closely attached to the groove portion of tube.
- Be careful not to damage O-ring and tube when replacing the O-ring.
- Connect tube until a click can be heard. Then tighten the nut or bolt by hand. Check that the O-ring is installed to tube correctly.
- Perform leak test and make sure that there is no leaks from connections after connecting line. Disconnect that line and replace the O-ring when the refrigerant leaking point is found. Then tighten connections of seal seat to the specified torque.

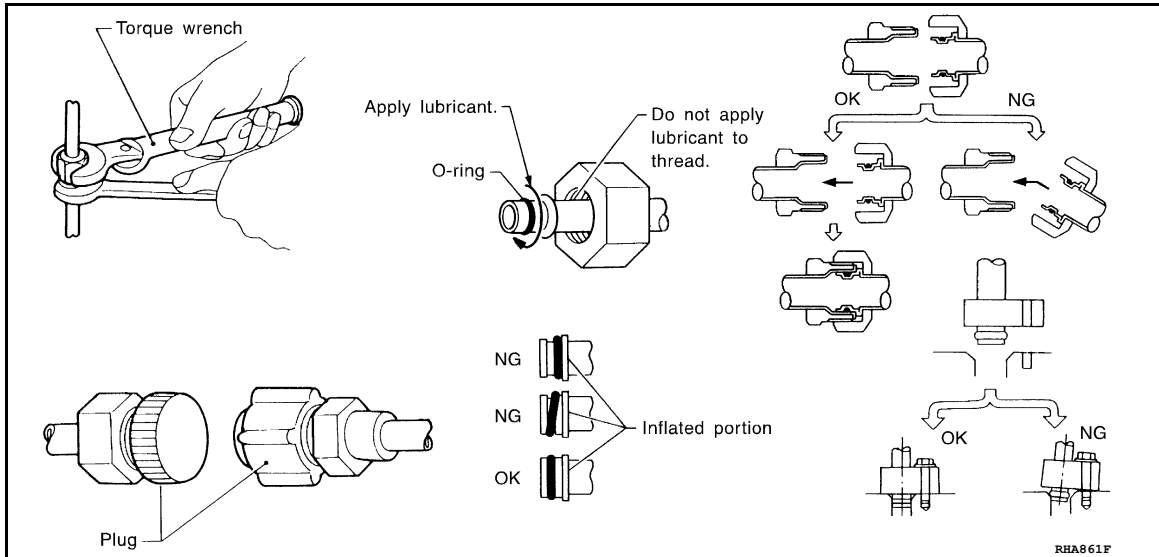

CONTAMINATED REFRIGERANT

Take appropriate steps shown below if a refrigerant other than pure HFC-134a (R-134a) is identified in a vehicle:

- Explain to the customer that environmental regulations prohibit the release of contaminated refrigerant into the atmosphere.
- Explain that recovery of the contaminated refrigerant could damage service equipment and refrigerant supply.
- Suggest the customer return the vehicle to the location of previous service where the contamination may have occurred.
- In case of repairing, recover the refrigerant using only **dedicated equipment and containers**. Do not recover contaminated refrigerant into the existing service equipment. Contact a local refrigerant product retailer for available service if the facility does not have dedicated recovery equipment. This refrigerant must be disposed of in accordance with all federal and local regulations. In addition, replacement of all refrigerant system components on the vehicle is recommended.
- The air conditioner warranty is void if the vehicle is within the warranty period. Please contact Nissan Customer Affairs for further assistance.

COMPRESSOR

CAUTION:

- Plug all openings to prevent moisture and foreign matter from entering.
- Store it in the same way as it is when mounted on the car when the compressor is removed.
- Follow "Maintenance of Oil Quantity in Compressor" exactly when replacing or repairing compressor. Refer to [HA-25, "Description"](#).
- Keep friction surfaces between clutch and pulley clean. Wipe it off by using a clean waste cloth moistened with thinner if the surface is contaminated with oil.
- Turn the compressor shaft by hand more than five turns in both directions after compressor service operation. This distributes oil equally inside the compressor. Let the engine idle and operate the compressor for one hour after the compressor is installed.
- Apply voltage to the new one and check for normal operation after replacing the compressor magnet clutch.

A
B
C
D
E
F
G
H
HAC
J
K
L
M
N
O
P

PRECAUTIONS

[AUTOMATIC AIR CONDITIONING]

< PRECAUTION >

LEAK DETECTION DYE

CAUTION:

- The A/C system contains a fluorescent leak detection dye used for locating refrigerant leaks. An ultraviolet (UV) lamp is required to illuminate the dye when inspecting for leaks.
- Always wear fluorescence enhancing UV safety goggles to protect eyes and enhance the visibility of the fluorescent dye.
- The fluorescent dye leak detector is not a replacement for an electronic leak detector (SST: J-41995). The fluorescent dye leak detector should be used in conjunction with an electronic leak detector (SST: J-41995) to pin-point refrigerant leaks.
- Read and follow all manufacture's operating instructions and precautions prior to performing the work for the purpose of safety and customer's satisfaction.
- A compressor shaft seal should not necessarily be repaired because of dye seepage. The compressor shaft seal should only be repaired after confirming the leak with an electronic leak detector (SST: J-41995).
- Always remove any remaining dye from the leak area after repairs are completed to avoid a misdiagnosis during a future service.
- Do not allow dye to come into contact with painted body panels or interior components. Clean immediately with the approved dye cleaner if dye is spilled. Fluorescent dye left on a surface for an extended period of time cannot be removed.
- Do not spray the fluorescent dye cleaning agent on hot surfaces (engine exhaust manifold, etc.).
- Do not use more than one refrigerant dye bottle [1/4 ounce (7.4 cc)] per A/C system.
- Leak detection dyes for HFC-134a (R-134a) and CFC-12 (R-12) A/C systems are different. Do not use HFC-134a (R-134a) leak detection dye in CFC-12 (R-12) A/C system or CFC-12 (R-12) leak detection dye in HFC-134a (R-134a) A/C system or A/C system damage may result.
- The fluorescent properties of the dye remains for three or more years unless a compressor malfunction occurs.

NOTE:

Identification

- Vehicles with factory installed fluorescent dye have a green label.
- Vehicles without factory installed fluorescent dye have a blue label.

Precaution for Service Equipment

INFOID:000000011136077

MANIFOLD GAUGE SET

Be certain that the gauge face indicates R-134a or 134a. Make sure the gauge set has 1/2"-16 ACME threaded connections for service hoses. Confirm the set has been used only with refrigerant HFC-134a (R-134a) along with specified oil.

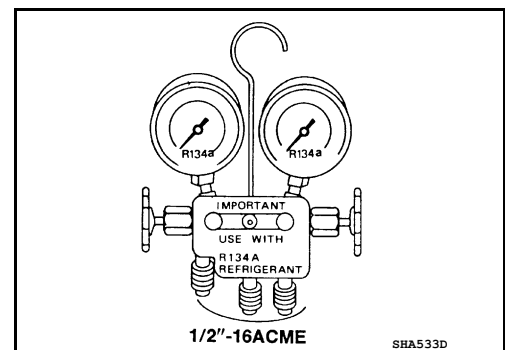

SERVICE HOSES

Be certain that the service hoses display the markings described (colored hose with black stripe). All hoses must include positive shut-off devices (either manual or automatic) near the end of the hoses opposite the manifold gauge.

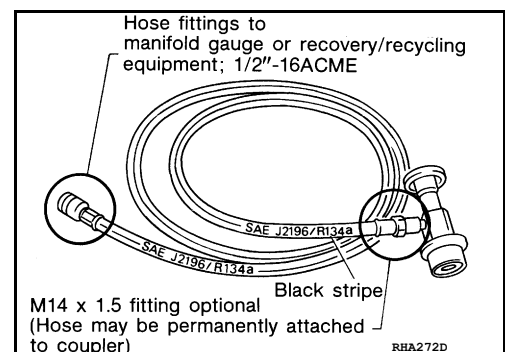

SERVICE COUPLERS

PRECAUTIONS

< PRECAUTION >

[AUTOMATIC AIR CONDITIONING]

Do not attempt to connect HFC-134a (R-134a) service couplers to a CFC-12 (R-12) A/C system. The HFC-134a (R-134a) couplers will not properly connect to the CFC-12 (R-12) system. However, if an improper connection is attempted, discharging and contamination may occur.

Shut-off valve rotation	A/C service valve
Clockwise	Open
Counterclockwise	Close

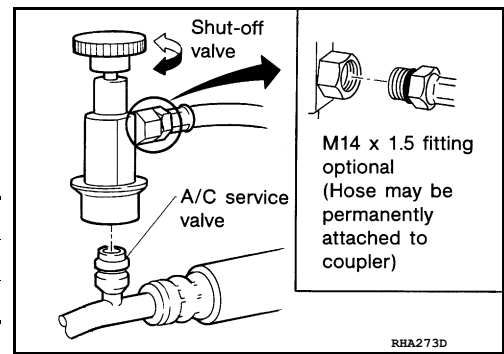

Precaution for Work

INFOID:000000011136078

- When removing or disassembling each component, be careful not to damage or deform it. If a component may be subject to interference, be sure to protect it with a shop cloth.
- When removing (disengaging) components with a screwdriver or similar tool, be sure to wrap the component with a shop cloth or vinyl tape to protect it.
- Protect the removed parts with a shop cloth and prevent them from being dropped.
- Replace a deformed or damaged clip.
- If a part is specified as a non-reusable part, always replace it with a new one.
- Be sure to tighten bolts and nuts securely to the specified torque.
- After installation is complete, be sure to check that each part works properly.
- Follow the steps below to clean components:
 - Water soluble dirt:
 - Dip a soft cloth into lukewarm water, wring the water out of the cloth and wipe the dirty area.
 - Then rub with a soft, dry cloth.
 - Oily dirt:
 - Dip a soft cloth into lukewarm water with mild detergent (concentration: within 2 to 3%) and wipe the dirty area.
 - Then dip a cloth into fresh water, wring the water out of the cloth and wipe the detergent off.
 - Then rub with a soft, dry cloth.
 - Do not use organic solvent such as thinner, benzene, alcohol or gasoline.
 - For genuine leather seats, use a genuine leather seat cleaner.

PREPARATION

< PREPARATION >

[AUTOMATIC AIR CONDITIONING]

PREPARATION

PREPARATION

Special Service Tool

INFOID:000000011136079

The actual shape of the tools may differ from those illustrated here.

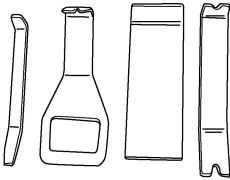
Tool number (TechMate No.) Tool name	Description
— (J-46534) Trim Tool Set  AWJIA0483ZZ	Removing trim components

Commercial Service Tool

INFOID:000000011136080

Tool name	Description
Power tool  PIIB1407E	Loosening nuts, screws and bolts

COMPONENT PARTS

< SYSTEM DESCRIPTION >

[AUTOMATIC AIR CONDITIONING]

SYSTEM DESCRIPTION

COMPONENT PARTS

FRONT AUTOMATIC AIR CONDITIONING SYSTEM

FRONT AUTOMATIC AIR CONDITIONING SYSTEM : Component Parts Location

INFOID:000000011136081

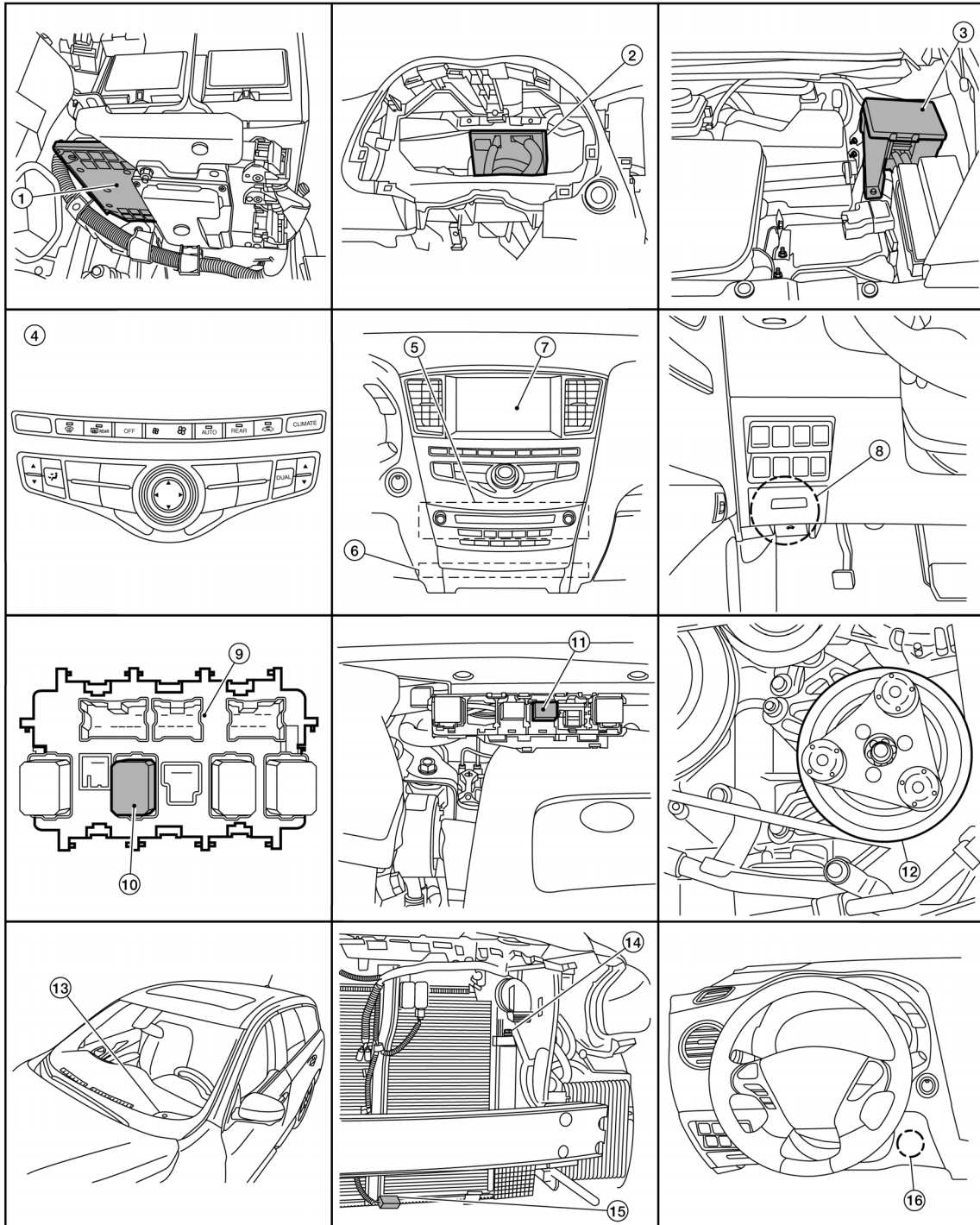

A
B
C
D
E
F
G
H
I
J
K
L
M
N
O
P

HAC

AL11A0546ZZ

COMPONENT PARTS

< SYSTEM DESCRIPTION >

[AUTOMATIC AIR CONDITIONING]

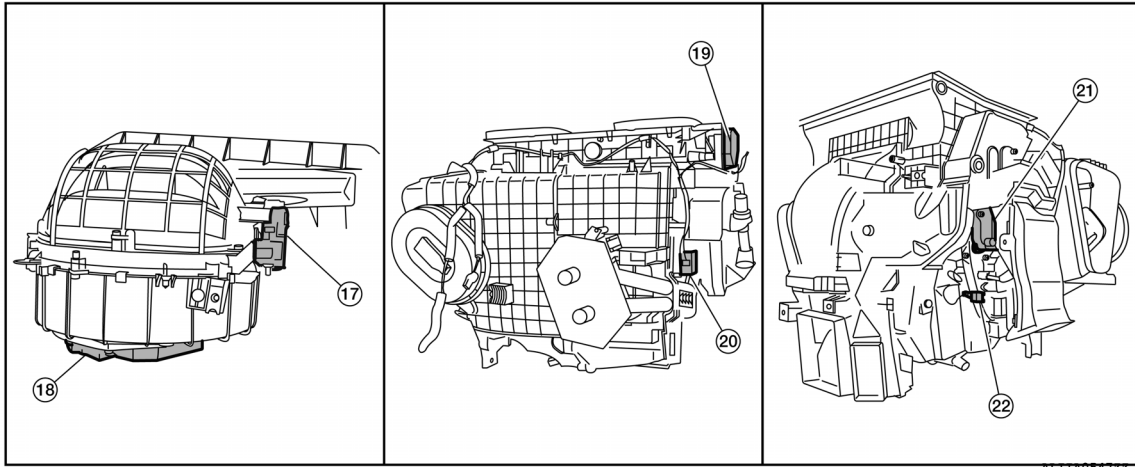

- | | | |
|---|--|---|
| 1. ECM | 2. BCM (view with combination meter removed) | 3. IPDM E/R. |
| 4. A/C and AV switch assembly | 5. AV control unit | 6. A/C auto amp. |
| 7. Display unit | 8. Fuse block (J/B) | 9. Fuse block (J/B) |
| 10. Front blower motor relay | 11. Accessory relay-2 | 12. A/C compressor |
| 13. Sunload sensor | 14. Refrigerant pressure sensor (view with front bumper fascia removed) | 15. Ambient sensor |
| 16. In-vehicle sensor | 17. Intake door motor (view with fresh air intake duct removed from vehicle) | 18. Front blower motor |
| 19. Mode door motor (front) (view with front A/C assembly removed from vehicle) | 20. Air mix door motor (driver side) | 21. Air mix door motor (passenger side) (view with front A/C assembly removed from vehicle) |
| 22. Intake sensor | | |

FRONT AUTOMATIC AIR CONDITIONING SYSTEM : Component Description

INFOID:000000011136082

Component	Description
A/C and AV switch assembly	Front A/C control operation signal is transmitted from the A/C and AV switch assembly to AV control unit via communication line.
A/C auto amp.	A/C auto amp. controls front automatic air conditioning system by inputting and calculating signals from each sensor and each switch.
A/C Compressor	Vaporized refrigerant is drawn into the A/C compressor from the evaporator, where it is compressed to a high pressure, high temperature vapor. The hot, compressed vapor is then discharged to the condenser.
Air mix door motor (Driver side)	The air mix door controls the mix of hot or cold air that enters the ventilation system. It is controlled by the A/C auto amp. based on the position of the temperature dial. The air mix door motor receives position commands from the A/C auto amp. and reports actual door position back via an LCU (Local Control Unit) installed inside the motor. Commands and responses are sent across the LIN (Local Interconnect Network) to each motor simultaneously, with each motor having its own unique address, thereby only responding to requests sent to its specific address. The LCU reads the door position from a Position Balanced Resistor (PBR), also part of the motor, and returns that information to the A/C auto amp.. The LCU switches the polarity of the circuits connected to the DC motor to drive the motor forward or backward as requested by the front air control. If the air mix door moves to a position less than 5% or more than 95% of its expected or allowed positions, the A/C auto amp. will set a DTC.

COMPONENT PARTS

< SYSTEM DESCRIPTION >

[AUTOMATIC AIR CONDITIONING]

Component	Description
Air mix door motor (Passenger side)	The air mix door controls the mix of hot or cold air that enters the ventilation system. It is controlled by the A/C auto amp. based on the position of the temperature dial. The air mix door motor receives position commands from the A/C auto amp. and reports actual door position back via an LCU (Local Control Unit) installed inside the motor. Commands and responses are sent across the LIN (Local Interconnect Network) to each motor simultaneously, with each motor having its own unique address, thereby only responding to requests sent to its specific address. The LCU reads the door position from a Position Balanced Resistor (PBR), also part of the motor, and returns that information to the A/C auto amp.. The LCU switches the polarity of the circuits connected to the DC motor to drive the motor forward or backward as requested by the front air control. If the air mix door moves to a position less than 5% or more than 95% of its expected or allowed positions, the A/C auto amp. will set a DTC.
Ambient sensor	The ambient sensor measures the temperature of the air surrounding the vehicle. The sensor uses a thermistor which is sensitive to the change in temperature. The electrical resistance of the thermistor decreases as temperature increases.
AV control unit	AV control unit transmits A/C and AV switch assembly operation signal to A/C auto amp. via CAN communication line.
BCM	BCM transmits blower motor ON signal to the front and rear blower motor relays.
Display unit	The display unit indicates operation status of the front and rear automatic air conditioning system.
ECM	The ECM sends a compressor ON request to the IPDM E/R based on the status of engine operation and load as well as refrigerant pressure information. If all the conditions are met for A/C operation, the ECM transmits the compressor ON request to the IPDM E/R. The ECM shares the refrigerant pressure sensor signal, engine RPM, and engine coolant temperature with the A/C auto amp. via CAN communication line.
Front blower motor	The front blower motor varies the speed at which the air flows through the ventilation system.
Front blower motor relay	The front blower motor relay controls the flow of current to fuse 17 and 27 in the Fuse Block (J/B). The relay is connected directly to ground, and is controlled by the BCM.
Fuse block (J/B)	Located in the passenger compartment, behind the left lower IP, the Fuse Block (J/B) contains the front blower motor relay and several fuses required for the air conditioner control system.
IPDM E/R	A/C relay is integrated in IPDM E/R. IPDM E/R operates A/C relay when A/C compressor request signal is received from ECM via CAN communication line.
Intake door motor	The intake door motor controls the position of the intake door. Fresh air is allowed to enter the cabin in one position, and recirculated inside air is allowed to enter in the other position. At times the A/C auto amp. may command partial fresh or recirculation based on evaporator or coolant temperatures. The intake door motor receives position commands from the front air control and reports actual door position back via an LCU (Local Control Unit) installed inside the motor. Commands and responses are sent across the LIN (Local Interconnect Network) to each motor simultaneously, with each motor having its own unique address, thereby only responding to requests sent to its specific address. The LCU reads the door position from a Position Balanced Resistor (PBR), also part of the motor, and returns that information to the front air control. The LCU switches the polarity of the circuits connected to the DC motor to drive the motor forward or backward as requested by the front air control. If the recirculation door moves to a position less than 5% or more than 95% of its expected or allowed positions, the front air control will set a DTC.

A
B
C
D
E
F
G
H
J
K
L
M
N
O
P

HAC

COMPONENT PARTS

< SYSTEM DESCRIPTION >

[AUTOMATIC AIR CONDITIONING]

Component	Description
Intake sensor	Intake sensor measures temperature of front evaporator fin temperature. The sensor uses a thermistor which is sensitive to the change in temperature. The electrical resistance of the thermistor decreases as temperature increases.
In-vehicle sensor	In-vehicle sensor measures temperature of intake air that flows through aspirator to passenger room. The sensor uses a thermistor which is sensitive to the change in temperature. The electrical resistance of the thermistor decreases as temperature increases.
Mode door motor (Front)	The mode door (front) controls the direction the conditioned air passes through the ventilation system. Through a series of levers and gears, the mode door controls the defrost door, the foot door, and the vent door. There are 5 preset positions: VENT, B/L, FOOT, D/F and DEF. The FOOT position can be set to allow some airflow through to the defroster vent or to completely block the defroster vent using the CONSULT. The mode door motor receives position commands from the A/C auto amp. and reports actual door position back via an LCU (Local Control Unit) installed inside the motor. Commands and responses are sent across the LIN (Local Interconnect Network) to each motor simultaneously, with each motor having its own unique address, thereby only responding to requests sent to its specific address. The LCU reads the door position from a Position Balanced Resistor (PBR), also part of the motor, and returns that information to the front air control. The LCU switches the polarity of the circuits connected to the DC motor to drive the motor forward or backward as requested by the front air control. The mode door has 5 expected positions and, therefore, can set up to 5 DTCs if the expected position is not reported back to the A/C auto amp.
Refrigerant pressure sensor	Refer to EC-38. "Refrigerant Pressure Sensor" (except for Mexico) or EC-570. "Refrigerant Pressure Sensor" (for Mexico).
Sunload sensor	Sunload sensor measures sunload amount. This sensor converts sunload amount to voltage signal by photodiode and transmits to A/C auto amp.

REAR AUTOMATIC AIR CONDITIONING SYSTEM

COMPONENT PARTS

< SYSTEM DESCRIPTION >

[AUTOMATIC AIR CONDITIONING]

REAR AUTOMATIC AIR CONDITIONING SYSTEM : Component Parts Location

INFOID:000000011136083

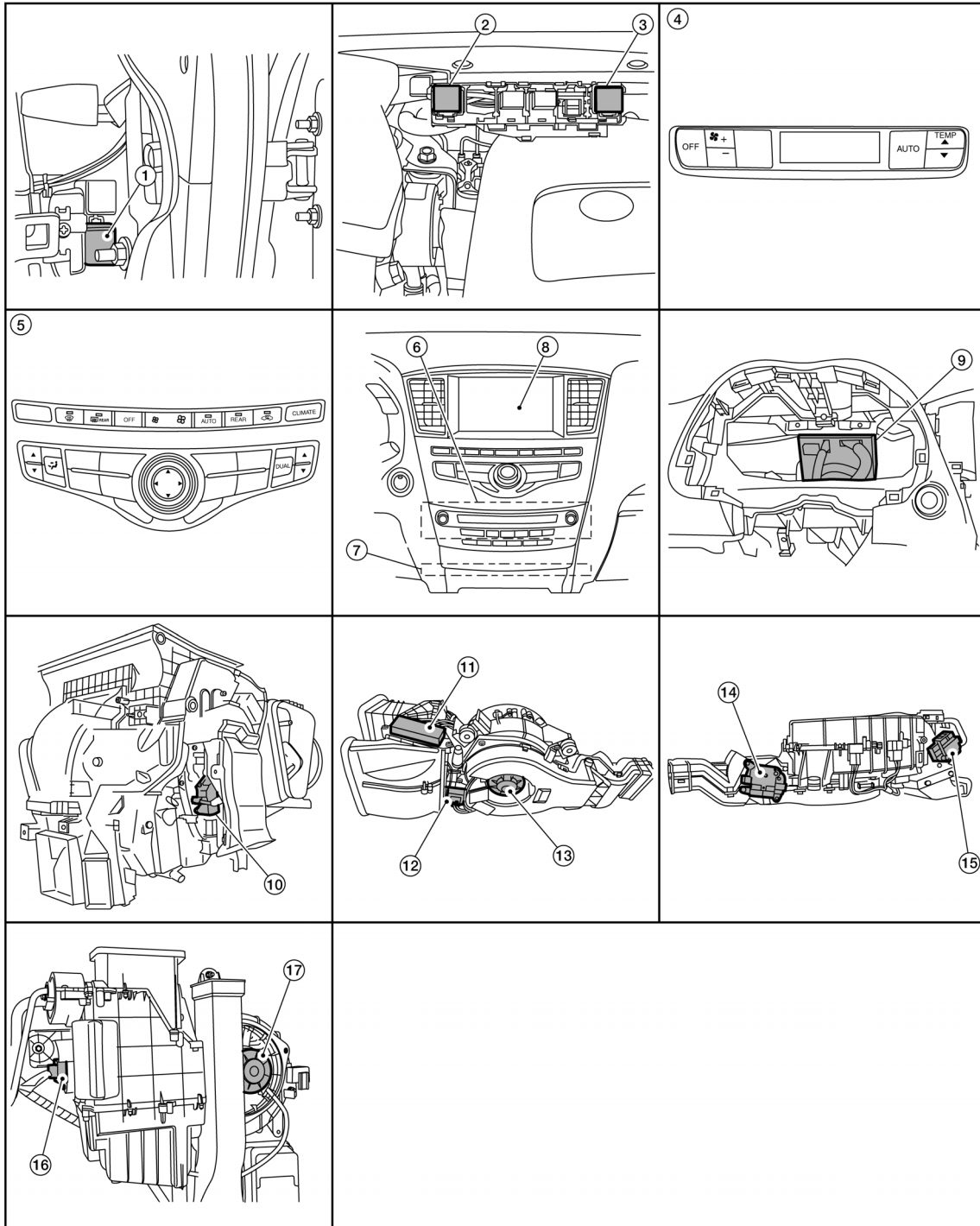

- | | | |
|---|---|--|
| 1. Rear blower motor relay (view with instrument panel removed) | 2. PTC relay 1 | 3. PTC relay 2 |
| 4. Rear air control | 5. A/C and AV switch assembly | 6. AV control unit |
| 7. A/C auto amp. | 8. Display unit | 9. BCM (view with combination meter removed) |
| 10. Air mix door motor (rear) (view with front A/C assembly removed from vehicle) | 11. PTC heater (view with rear booster assembly removed from vehicle) | 12. Rear blower motor resistor 1 |

ALIIA0550ZZ

A
B
C
D
E
F
G
H
HAC
J
K
L
M
N
O

COMPONENT PARTS

< SYSTEM DESCRIPTION >

[AUTOMATIC AIR CONDITIONING]

- | | | |
|---|---|----------------------------|
| 13. Rear blower motor 1 | 14. Rear shut-off door motor (view with rear booster assembly removed from vehicle) | 15. Mode door motor (rear) |
| 16. Rear blower motor resistor 2 (view with luggage side lower finisher RH removed) | 17. Rear blower motor 2 | |

REAR AUTOMATIC AIR CONDITIONING SYSTEM : Component Description

INFOID:000000011136084

Component	Description
A/C auto amp.	A/C auto amp. controls the automatic air conditioning system by inputting and calculating signals from each sensor and each switch.
A/C and AV switch assembly	Rear air control operation signal is transmitted from the A/C and AV switch assembly to AV control unit via communication line.
Air mix door motor (Rear)	The air mix door (rear) controls the mix of hot or cold air that enters the ventilation system. It is controlled by the A/C auto amp. based on the position of the temperature dial. The air mix door motor (rear) receives position commands from the A/C auto amp. and reports actual door position back via an LCU (Local Control Unit) installed inside the motor. Commands and responses are sent across the LIN (Local Interconnect Network) to each motor simultaneously, with each motor having its own unique address, thereby only responding to requests sent to its specific address. The LCU reads the door position from a Position Balanced Resistor (PBR), also part of the motor, and returns that information to the A/C auto amp.. The LCU switches the polarity of the circuits connected to the DC motor to drive the motor forward or backward as requested by the front air control. If the air mix door (rear) moves to a position less than 5% or more than 95% of its expected or allowed positions, the A/C auto amp. will set a DTC.
AV control unit	AV control unit transmits A/C and AV switch assembly operation signal to A/C auto amp. via CAN communication line.
BCM	BCM transmits blower motor ON signal to the rear blower motor relay.
Display unit	The display unit indicates operation status of the front and rear automatic air conditioning system.
Mode door motor (Rear)	The mode door (rear) controls the direction the conditioned air passes through the ventilation system. The mode door motor (rear) receives position commands from the A/C auto amp. and reports actual door position back via an LCU (Local Control Unit) installed inside the motor. Commands and responses are sent across the LIN (Local Interconnect Network) to each motor simultaneously, with each motor having its own unique address, thereby only responding to requests sent to its specific address. The LCU reads the door position from a Position Balanced Resistor (PBR), also part of the motor, and returns that information to the front air control. The LCU switches the polarity of the circuits connected to the DC motor to drive the motor forward or backward as requested by the A/C auto amp.. The mode door has 2 expected positions and, therefore, can set up to 2 DTCs if the expected position is not reported back to the A/C auto amp.
PTC heater	The positive temperature coefficient (PTC) heater provides supplemental heat to the rear seating by warming the air as it flows through its electrically controlled heating grid.
PTC heater relay	The PTC heater relay controls the flow of current to the PTC heater. The relay is controlled by the A/C auto amp.
Rear blower motor 1	The rear blower motor-1 varies the speed at which the air flows through the ventilation system.
Rear blower motor 2	The rear blower motor-2 varies the speed at which the air flows through the ventilation system.

COMPONENT PARTS

< SYSTEM DESCRIPTION >

[AUTOMATIC AIR CONDITIONING]

Component	Description
Rear blower motor relay	The rear blower motor relay controls the flow of current to the rear blower motor. The relay is connected directly to ground, and is controlled by the BCM.
Rear shut-off door motor	The rear shut-off door controls the conditioned air through the ventilation system. The rear shut-off door motor receives position commands from the A/C auto amp. and reports actual door position back via an LCU (Local Control Unit) installed inside the motor. Commands and responses are sent across the LIN (Local Interconnect Network) to each motor simultaneously, with each motor having its own unique address, thereby only responding to requests sent to its specific address. The LCU reads the door position from a Position Balanced Resistor (PBR), also part of the motor, and returns that information to the front air control. The LCU switches the polarity of the circuits connected to the DC motor to drive the motor forward or backward as requested by the A/C auto amp.. The mode door has 2 expected positions and therefore will set a DTC if the expected position is not reported back to the A/C auto amp.

ACCS (ADVANCED CLIMATE CONTROL SYSTEM)

ACCS (ADVANCED CLIMATE CONTROL SYSTEM) : Component Parts Location

INFOID:000000011136085

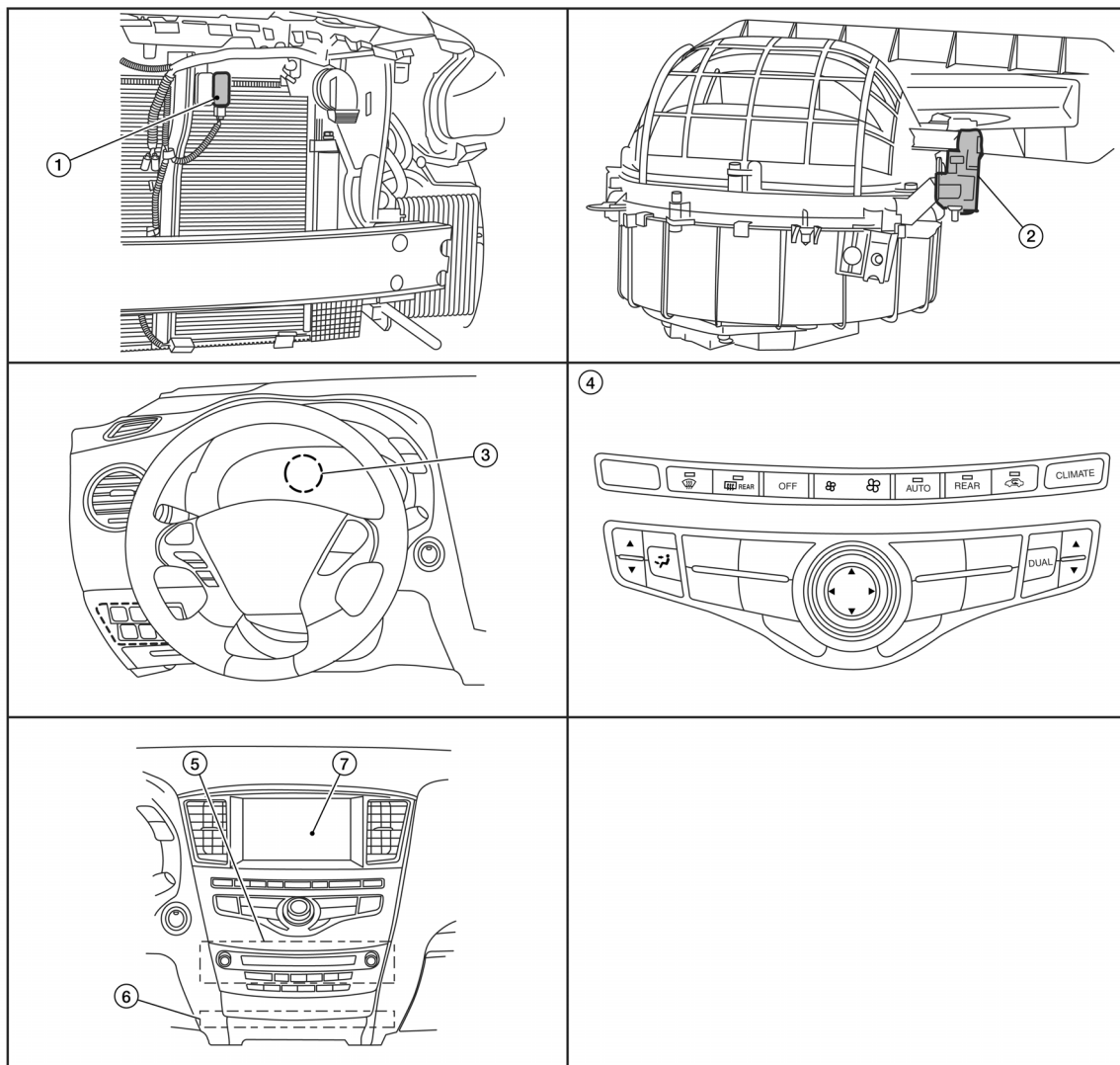

ALIIA0549ZZ

A
B
C
D
E
F
G
H
HAC
J
K
L
M
N
O
P

COMPONENT PARTS

< SYSTEM DESCRIPTION >

[AUTOMATIC AIR CONDITIONING]

- | | | |
|--|---|------------------|
| 1. Exhaust gas / outside odor detecting sensor (view with front bumper fascia removed) | 2. Intake door motor (view with fresh air intake duct removed from vehicle) | 3. Ionizer |
| 4. A/C and AV switch assembly | 5. AV control unit | 6. A/C auto amp. |
| 7. Display unit | | |

ACCS (ADVANCED CLIMATE CONTROL SYSTEM) : Component Description

INFOID:000000011136086

Component	Description
A/C and AV switch assembly	Front A/C control operation signal is transmitted from the A/C and AV switch assembly to AV control unit via communication line.
A/C auto amp.	A/C auto amp. controls ACCS (advanced climate control system) by inputting and calculating signals from each sensor and each switch. A/C auto amp. has self-diagnosis function. Diagnosis of ACCS (advanced climate control system) can be performed quickly.
AV control unit	AV control unit transmits A/C switch operation signal to A/C auto amp. via CAN communication line.
Display unit	Display unit indicates operation status of ACCS (advanced climate control system).
Exhaust gas / outside odor detecting sensor	Exhaust gas / outside odor detecting sensor measures exhaust gas outside of the passenger room. In addition to previous exhaust gas detection function, unpleasant odor in ambient atmosphere is also measured.
Intake door motor	The intake door motor controls the position of the intake door. Fresh air is allowed to enter the cabin in one position, and recirculated inside air is allowed to enter in the other position. At times the front air control may command partial fresh or recirculation based on evaporator or coolant temperatures. The intake door motor receives position commands from the A/C auto amp. and reports actual door position back via an LCU (Local Control Unit) installed inside the motor. Commands and responses are sent across the LIN (Local Interconnect Network) to each motor simultaneously, with each motor having its own unique address, thereby only responding to requests sent to its specific address. The LCU reads the door position from a Position Balanced Resistor (PBR), also part of the motor, and returns that information to the front air control. The LCU switches the polarity of the circuits connected to the DC motor to drive the motor forward or backward as requested by the front air control. If the recirculation door moves to a position less than 5% or more than 95% of its expected or allowed positions, the A/C auto amp will set a DTC.
Ionizer	Ionizer generates an approximately equal proportional amount of positive and negative ions in the air.

SYSTEM

< SYSTEM DESCRIPTION >

[AUTOMATIC AIR CONDITIONING]

SYSTEM

FRONT AUTOMATIC AIR CONDITIONING SYSTEM

FRONT AUTOMATIC AIR CONDITIONING SYSTEM : System Diagram

INFOID:000000011136087

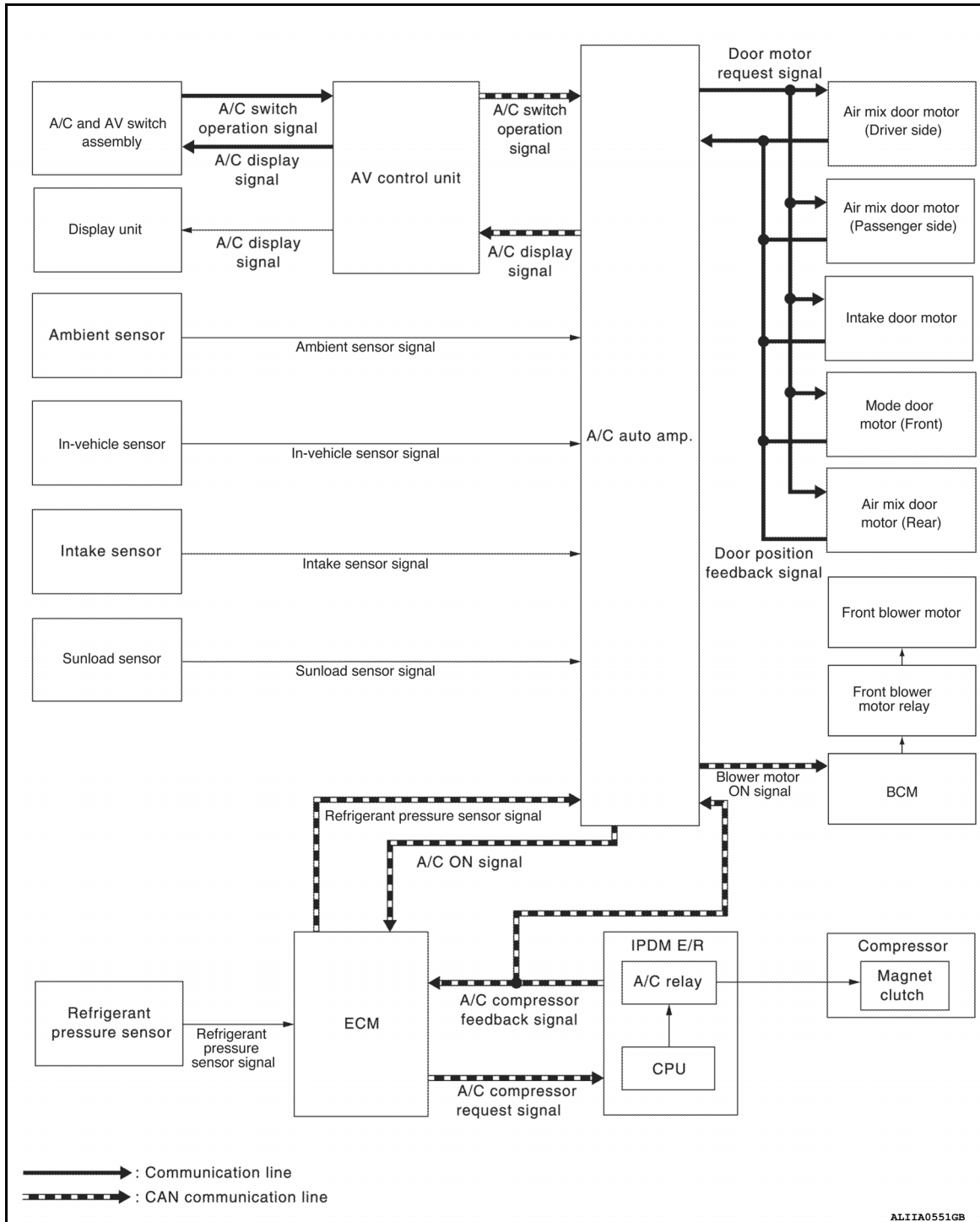

A
B
C
D
E
F
G
H
I
J
K
L
M
N
O
P

HAC

FRONT AUTOMATIC AIR CONDITIONING SYSTEM : System Description

INFOID:000000011136088

- Front automatic air conditioning system is controlled by each function of A/C auto amp., ECM, IPDM E/R and BCM.

Control by A/C auto amp.

- [HAC-20, "FRONT AUTOMATIC AIR CONDITIONING SYSTEM : Air Flow Control"](#)
- [HAC-21, "FRONT AUTOMATIC AIR CONDITIONING SYSTEM : Air Inlet Control"](#)

SYSTEM

< SYSTEM DESCRIPTION >

[AUTOMATIC AIR CONDITIONING]

- [HAC-22. "FRONT AUTOMATIC AIR CONDITIONING SYSTEM : Air Outlet Control"](#)
- [HAC-22. "FRONT AUTOMATIC AIR CONDITIONING SYSTEM : Compressor Control"](#)
- [HAC-23. "FRONT AUTOMATIC AIR CONDITIONING SYSTEM : Door Control"](#)
- [HAC-25. "FRONT AUTOMATIC AIR CONDITIONING SYSTEM : Temperature Control"](#)
- Correction for input value of each sensor

Ambient sensor (setting temperature correction)

- A/C auto amp. controls passenger room temperature so that the optimum level always matches the temperature level that the passenger may feel. Correction is applied to the target temperature that is set using temperature control dial, according to ambient temperature detected by ambient sensor.

In-vehicle sensor [in-vehicle temperature (front side) correction]

- Passenger room temperature (front side) detected by in-vehicle sensor is corrected for each front air conditioning control (driver side and passenger side).

Intake sensor (intake temperature correction)

- A/C auto amp. performs correction to change recognition intake temperature of A/C auto amp. quickly when difference is large between recognition intake temperature and intake temperature detected by intake temperature sensor. The correction is performed to change recognition intake temperature slowly when difference is small.

Sunload sensor (sunload amount correction)

- Sunload amount detected by sunload sensor is corrected for each air conditioning control.
- A/C auto amp. performs correction to change recognition sunload amount of A/C auto amp. slowly when sunload amount changes quickly, for example when entering or exiting a tunnel.

Control by ECM

- Cooling fan control

Refer to [EC-50. "COOLING FAN CONTROL : System Description"](#) (except for Mexico) or [EC-581. "COOLING FAN CONTROL : System Description"](#) (for Mexico).

- Air conditioning cut control

Refer to [EC-579. "AIR CONDITIONING CUT CONTROL : System Description"](#) (except for Mexico) or [EC-579. "AIR CONDITIONING CUT CONTROL : System Description"](#) (for Mexico).

Control by IPDM E/R

- Relay control

Refer to [PCS-6. "RELAY CONTROL SYSTEM : System Description"](#).

- Cooling fan control

Refer to [EC-50. "COOLING FAN CONTROL : System Description"](#) (except for Mexico) or [EC-581. "COOLING FAN CONTROL : System Description"](#) (for Mexico).

Control by BCM

- Relay control

Refer to [BCS-6. "BODY CONTROL SYSTEM : System Description"](#).

- Front A/C control (A/C and AV switch assembly) transmits the commands for front automatic air conditioning system operation to AV control unit via communication line, then AV control unit transmits the commands to A/C auto amp. via CAN communication. A/C auto amp. transmits each indication information to AV control unit via CAN communication. AV control unit displays each indication information that is received.

FRONT AUTOMATIC AIR CONDITIONING SYSTEM : Air Flow Control

INFOID:000000011136090

DESCRIPTION

- A/C auto amp. changes duty ratio of blower motor drive signal and controls air flow continuously. When air flow is increased, duty ratio of front blower motor control signal gradually increases to prevent a sudden increase in air flow.
- In addition to manual control and automatic control, air flow control is consist of starting fan speed control, low coolant temperature starting control, high in-vehicle temperature starting control and fan speed control at door motor operation

AUTOMATIC AIR FLOW CONTROL

- A/C auto amp. decides target air flow depending on target air mix door (front) opening angle.
- A/C auto amp. changes duty ratio of front blower motor control signal and controls the air flow continuously so that air flow matches the target air flow.

SYSTEM

< SYSTEM DESCRIPTION >

[AUTOMATIC AIR CONDITIONING]

- When air outlet is VENT or B/L, the minimum air flow is changed depending on sunload.

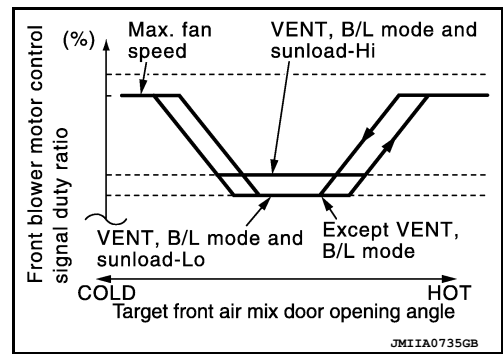

STARTING AIR FLOW CONTROL

- When front blower motor is activated, A/C auto amp. gradually increases duty ratio of front blower motor control signal to prevent a sudden increase in discharge air flow.
- It takes approximately 8 seconds for air flow to reach HI from LOW.

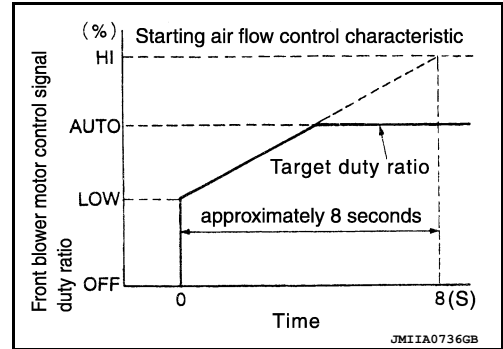

LOW COOLANT TEMPERATURE STARTING CONTROL

If the engine coolant temperature is 56°C (133°F) or less, to prevent a cold discharged air flow, A/C auto amp. suspends front blower motor activation for the maximum 150 seconds depending on target air mix door (front) opening angle. After this, front blower motor control signal is increased gradually, and front blower motor is activated.

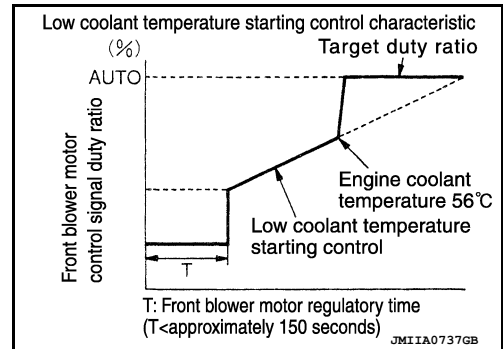

HIGH IN-VEHICLE TEMPERATURE STARTING CONTROL

When front evaporator fin temperature is high [intake sensor value is 35°C (95°F) or more], to prevent a hot discharged air flow, A/C auto amp. suspends front blower motor activation for approximately 3 seconds so that front evaporator is cooled by refrigerant.

FAN SPEED CONTROL AT DOOR MOTOR OPERATION

When mode door motor (front) is activated while air flow is more than the specified value, A/C auto amp. reduces fan speed temporarily so that mode door (front) moves smoothly.

FRONT AUTOMATIC AIR CONDITIONING SYSTEM : Air Inlet Control

INFOID:000000011136091

The intake door is automatically controlled by the temperature setting, ambient temperature, in-vehicle temperature, intake temperature, amount of sunload and ON/OFF operation of the compressor. Intake door automatic control selects FRE, 20% FRE, or REC depending on a target air mix door (front) opening angle, based on in-vehicle temperature, ambient temperature, and sunload.

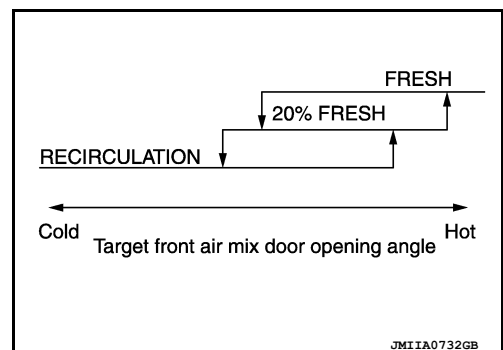

SYSTEM

< SYSTEM DESCRIPTION >

[AUTOMATIC AIR CONDITIONING]

FRONT AUTOMATIC AIR CONDITIONING SYSTEM : Air Outlet Control

INFOID:000000011136092

- While air outlet is in automatic control, A/C auto amp. selects the mode door (front) position depending on a target air mix door (front) angle and outlet air temperature calculated from sunload.
- If ambient temperature is excessively low, D/F is selected to prevent windshield fogging when air outlet is set to FOOT.

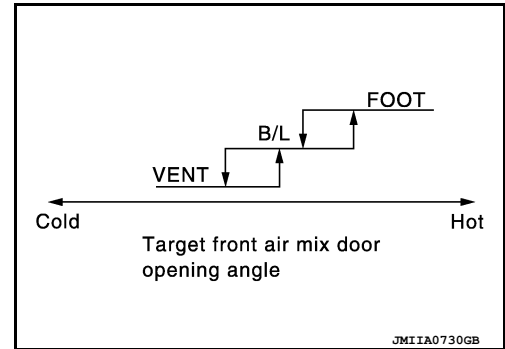

FRONT AUTOMATIC AIR CONDITIONING SYSTEM : Compressor Control

INFOID:000000011136093

DESCRIPTION

- When the compressor activation condition is satisfied while blower motor is activated, A/C auto amp. transmits A/C ON signal and blower fan ON signal to ECM via CAN communication.
- ECM judges that the compressor can be activated depending on each sensors state (refrigerant pressure sensor signal and others) and transmits A/C compressor request signal to IPDM E/R via CAN communication.
- IPDM E/R turns A/C relay ON and activates the compressor depending on request from ECM.

COMPRESSOR PROTECTION CONTROL AT PRESSURE MALFUNCTION

When high-pressure side value that is detected by refrigerant pressure sensor is as per the following state, ECM requests IPDM E/R to turn A/C relay OFF and stops the compressor.

- 3.12 MPa (31.82 kg/cm², 452.4 psi) or more (When the engine speed is less than 1,500 rpm)
- 2.74 MPa (27.95 kg/cm², 397.3 psi) or more (When the engine speed is 1,500 rpm or more)
- 0.14 MPa (1.43 kg/cm², 20.3 psi) or less

COMPRESSOR OIL CIRCULATION CONTROL

When the engine starts while the engine coolant temperature is 56°C (133°F) or less, ECM activates the compressor for approximately 6 seconds and circulates the compressor lubricant once.

LOW TEMPERATURE PROTECTION CONTROL

- When intake sensor detects that front evaporator fin temperature is 2.5°C (37°F) or less, A/C auto amp. requests ECM to turn compressor OFF, and stops the compressor.
- When the front evaporator fin temperature returns to 5.0°C (41°F) or more, the compressor is activated.

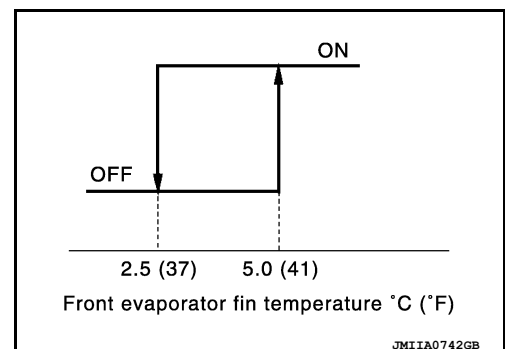

OPERATING RATE CONTROL

When set temperature is other than fully cold or air outlet is "VENT", "B/L" or "FOOT" A/C auto amp. controls the compressor activation depending on ambient temperature.

AIR CONDITIONING CUT CONTROL

When set engine is running is excessively high load condition, ECM requests IPDM E/R to turn A/C relay OFF, and stops the compressor. Refer to [EC-579. "AIR CONDITIONING CUT CONTROL : System Description"](#) (except for Mexico) or [EC-579. "AIR CONDITIONING CUT CONTROL : System Description"](#) (for Mexico) for details.

SYSTEM

< SYSTEM DESCRIPTION >

[AUTOMATIC AIR CONDITIONING]

FRONT AUTOMATIC AIR CONDITIONING SYSTEM : Door Control

INFOID:000000011136094

DOOR MOTOR CONTROL

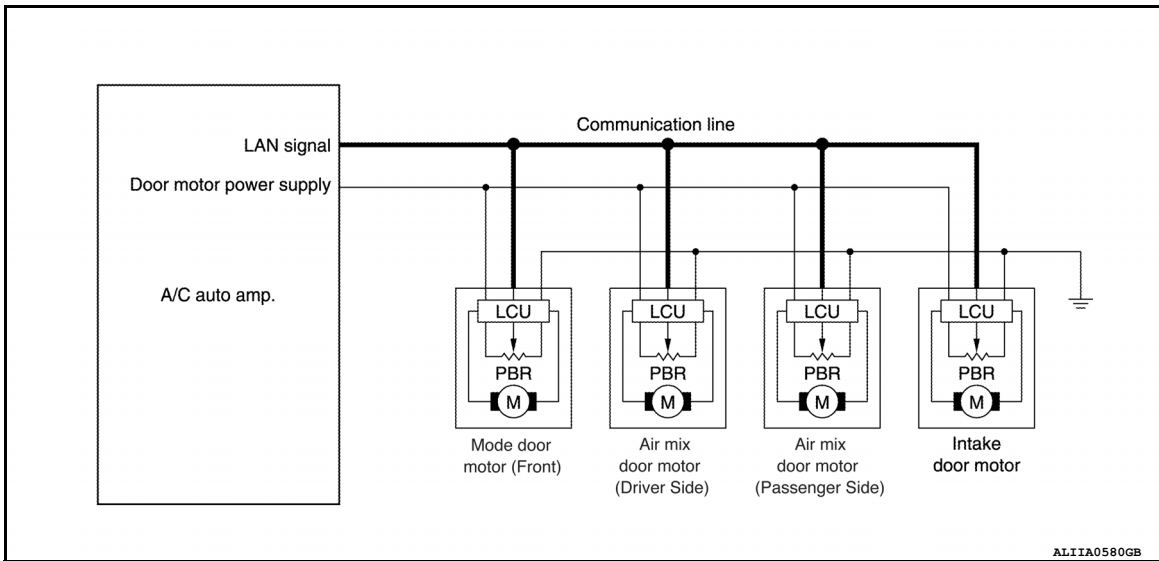

- LCU (Local Control Unit) is built into each door motor, and detects door position by PBR (Potentiometer Balance Resistor).
- A/C auto amp. communicates with each LCU via communication line and receives each door position feedback signal from each LCU.
- Each LCU controls each door to the appropriate position depending on the control signal from A/C auto amp.
- Each LCU transmits the signal of door movement completion to A/C auto amp., when the door movement is completed.

SWITCH AND THEIR CONTROL FUNCTION

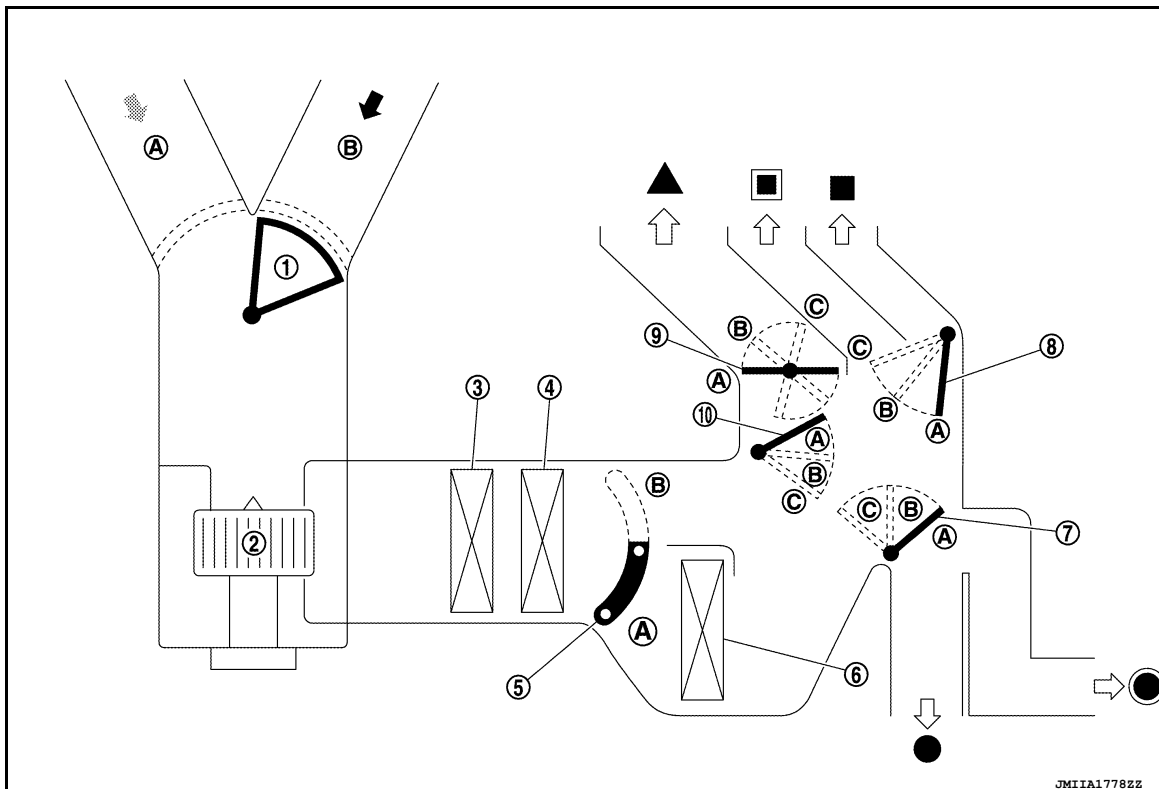

SYSTEM

< SYSTEM DESCRIPTION >

[AUTOMATIC AIR CONDITIONING]

- | | | |
|---------------------|-------------------------|-------------------------|
| 1. Intake door | 2. Front blower motor | 3. In-cabin microfilter |
| 4. Front evaporator | 5. Air mix door (front) | 6. Front heater core |
| 7. Foot door | 8. Ventilator door | 9. Defroster door |
| 10. Max. cool door | | |
| Fresh air | Recirculation air | Discharge air |
| Defroster | Center ventilator | Side ventilator |
| Front foot | Rear foot | |

Switch position		Door position								
		Mode door (front)				Intake door	Air mix door (front)			
		Ventilator door	Max. cool door	Defroster door	Foot door		(Driver side)	(Passenger side)		
AUTO switch		AUTO								
MODE switch			A	A	A	A	—	—	—	
			B	B	A	B				
			C	C	B	B				
			C	B	B	B				
DEF switch			C	A	C	C				
Intake switch*							A			
							B			
Temperature control switch (Driver side)	DUAL switch: OFF	Full cold [18°C (60°F)]					A			
		18.5°C – 31.5°C (61°F – 89 °F)					AUTO			
		Full hot [32°C (90°F)]					B			
Temperature control switch (Driver side)	DUAL switch: ON	Full cold [18°C (60°F)]	—	—	—	—	A			
		18.5°C – 31.5°C (61°F – 89 °F)					AUTO			
		Full hot [32°C (90°F)]					B			
Full cold [18°C (60°F)]						—		A		
18.5°C – 31.5°C (61°F – 89 °F)						—		AUTO		
Full hot [32°C (90°F)]						—		B		
Temperature control switch (Passenger side)							—			
ON-OFF switch		OFF	C	C	B	B	B	—		

*: Inlet status is displayed by indicator during activating automatic control

AIR DISTRIBUTION

SYSTEM

< SYSTEM DESCRIPTION >

[AUTOMATIC AIR CONDITIONING]

Discharge air flow						
MODE/DEF set position	Condition	Air outlet/distribution				
		Ventilator		Foot		Defroster
		Center	Side	Front	Rear	
	DUAL switch: OFF	50%	50%	—		—
		26%	30%	30%	14%	—
		—	14%	40%	16.5%	29.5%
		—	14%	35%	16%	35%
		—	12%	—		88%

FRONT AUTOMATIC AIR CONDITIONING SYSTEM : Temperature Control

INFOID:000000011136095

- When ignition switch is in the ON position, A/C auto amp. always automatically controls temperature regardless of front air conditioning operational state.
- A/C auto amp. calculates the target air mix door (front) opening angle depending on set temperature, in-vehicle temperature, ambient temperature, and sunload.
- Air mix door (front) is controlled depending on the comparison of current air mix door (front) opening angle and target air mix door (front) opening angle.
- Regardless of in-vehicle temperature, ambient temperature, and sunload, air mix door (front) is fixed at the fully cold position when set temperature is 18.0°C (60°F), and at the fully hot position when set temperature is 32.0°C (90°F).

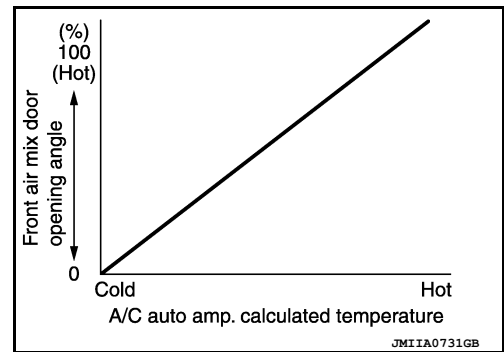

FRONT AUTOMATIC AIR CONDITIONING SYSTEM : Fail-safe

INFOID:000000011136096

FAIL-SAFE FUNCTION

If a communication error exists between the A/C auto amp., and the AV control unit and preset switch for 30 seconds or longer, air conditioning is controlled under the following conditions:

When ambient temperature is less than 3°C (37°F) and engine coolant temperature is less than 56°C (133°F)

- Compressor** : ON
- Air outlet** : DEF
- Air inlet** : FRE (Fresh air intake)
- Blower fan speed** : AUTO
- Set temperature** : Setting before communication error occurs

When ambient temperature is 3°C (37°F) or more, or engine coolant temperature is 56°C (133°F) or more

- Compressor** : ON
- Air outlet** : AUTO
- Air inlet** : 20% FRE (20% fresh air intake)
- Blower fan speed** : AUTO
- Set temperature** : Setting before communication error occurs

REAR AUTOMATIC AIR CONDITIONING SYSTEM

SYSTEM

< SYSTEM DESCRIPTION >

[AUTOMATIC AIR CONDITIONING]

REAR AUTOMATIC AIR CONDITIONING SYSTEM : System Diagram

INFOID:000000011136097

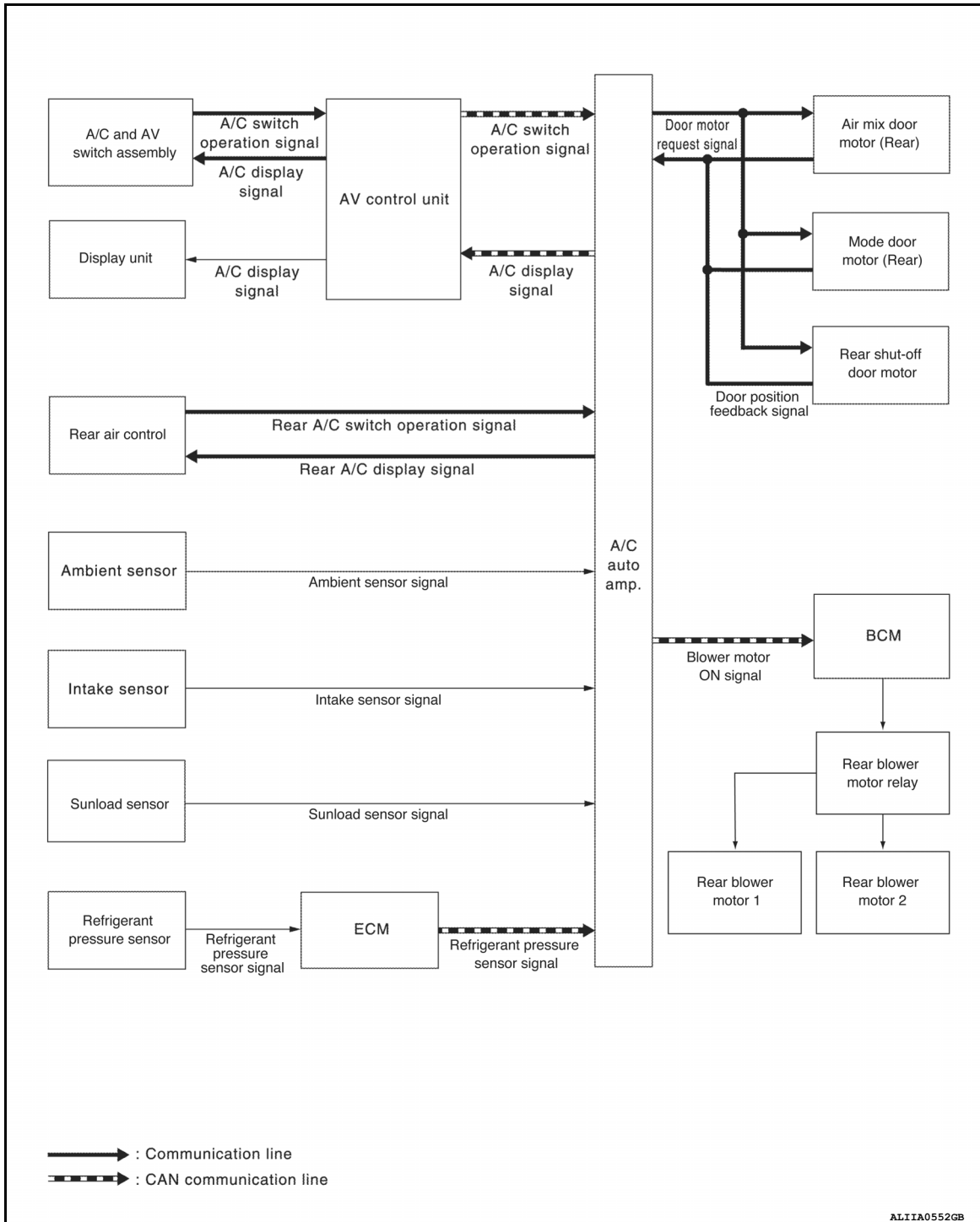

REAR AUTOMATIC AIR CONDITIONING SYSTEM : System Description

INFOID:000000011136098

- Rear automatic air conditioning system is controlled by each function of A/C auto amp.

Control by A/C auto amp.

- [HAC-27. "REAR AUTOMATIC AIR CONDITIONING SYSTEM : Air Flow Control"](#)
- [HAC-28. "REAR AUTOMATIC AIR CONDITIONING SYSTEM : Air Outlet Control"](#)
- [HAC-29. "REAR AUTOMATIC AIR CONDITIONING SYSTEM : Door Control"](#)
- [HAC-30. "REAR AUTOMATIC AIR CONDITIONING SYSTEM : Temperature Control"](#)
- Correction for input value of each sensor

Ambient sensor (setting temperature correction)

SYSTEM

< SYSTEM DESCRIPTION >

[AUTOMATIC AIR CONDITIONING]

- A/C auto amp. controls passenger room temperature so that the optimum level always matches the temperature level that passenger may feel. Correction is applied to the target temperature that is set using temperature control dial, according to ambient temperature detected by ambient sensor.

Intake sensor (intake temperature correction)

- A/C auto amp. performs correction to change recognition intake temperature of A/C auto amp. quickly when difference is large between recognition intake temperature and intake temperature detected by intake temperature sensor. The correction is performed to change recognition intake temperature slowly when difference is small.

Sunload sensor (sunload amount correction)

- Sunload amount detected by sunload sensor is corrected for each rear automatic air conditioning control.
- A/C auto amp. performs correction to change recognition sunload amount of A/C auto amp. slowly when sunload amount changes quickly, for example when entering or exiting a tunnel.

Operation by front controller

- Front A/C control (A/C and AV switch assembly) transmits the commands for rear automatic air conditioning system operation to AV control unit via communication line, then AV control unit transmits the commands to A/C auto amp. via CAN communication. A/C auto amp. transmits each indication information to AV control unit via CAN communication. AV control unit displays each indication information that is received.

Operation by rear controller

- Rear air control transmits the commands for rear automatic air conditioning system operation to A/C auto amp. via communication line.

REAR AUTOMATIC AIR CONDITIONING SYSTEM : Air Flow Control

INFOID:000000011136100

DESCRIPTION

- A/C auto amp. changes duty ratio of rear blower motor drive signal and controls air flow continuously. When air flow is increased, duty ratio of rear blower motor control signal gradually increases to prevent a sudden increase in air flow.
- In addition to manual control and automatic control, air flow control is composed of starting fan speed control, low coolant temperature starting control, high in-vehicle temperature starting control and fan speed control at door motor operation

AUTOMATIC AIR FLOW CONTROL

- A/C auto amp. decides target air flow depending on target air mix door (rear) opening angle.
- A/C auto amp. changes duty ratio of rear blower motor control signal and controls the air flow continuously so that air flow matches to target air flow.
- When air outlet is VENT, the minimum air flow is changed depending on sunload.

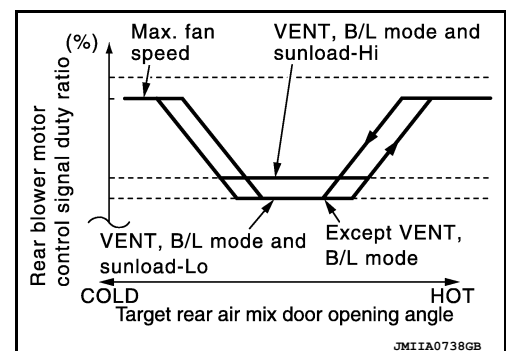

STARTING AIR FLOW CONTROL

SYSTEM

< SYSTEM DESCRIPTION >

[AUTOMATIC AIR CONDITIONING]

- When rear blower motor is activated, A/C auto amp. gradually increases duty ratio of rear blower motor control signal to prevent a sudden increase in discharge air flow.
- It takes approximately 8 seconds for air flow to reach HI from LOW.

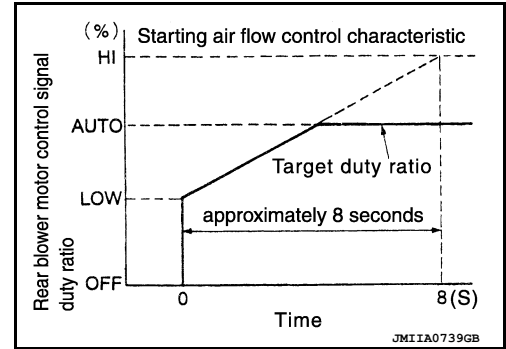

LOW COOLANT TEMPERATURE STARTING CONTROL

If the engine coolant temperature is 56°C (133°F) or less, to prevent a cold discharged air flow, A/C auto amp. suspends rear blower motor activation for the maximum 150 seconds depending on target air mix door (rear) opening angle. After this, rear blower motor control signal is increased gradually, and rear blower motor is activated.

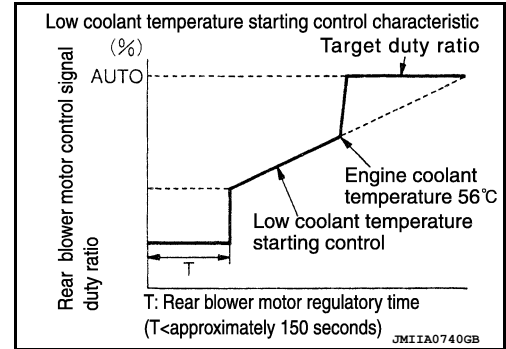

HIGH IN-VEHICLE TEMPERATURE STARTING CONTROL

When front evaporator fin temperature is high [intake sensor value is 35°C (95°F) or more], to prevent a hot discharged air flow, A/C auto amp. suspends rear blower motor activation for approximately 3 seconds so that rear evaporator is cooled by refrigerant.

FAN SPEED CONTROL AT DOOR MOTOR OPERATION

When mode door motor (rear) is activated while air flow is more than the specified value, A/C auto amp. reduces temporarily fan speed so that mode door (rear) moves smoothly.

REAR AUTOMATIC AIR CONDITIONING SYSTEM : Air Outlet Control

INFOID:000000011136101

- While air outlet is in automatic control, A/C auto amp. selects the mode door (rear) position depending on a target air mix door (rear) angle and outlet air temperature calculated from sunload.

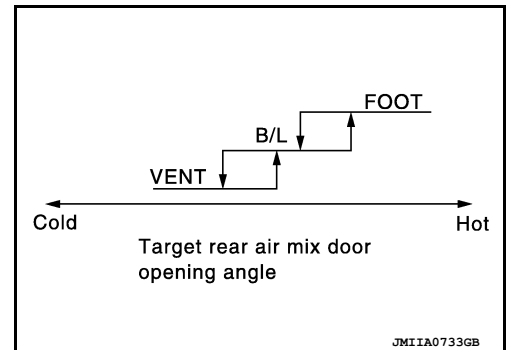

SYSTEM

< SYSTEM DESCRIPTION >

[AUTOMATIC AIR CONDITIONING]

REAR AUTOMATIC AIR CONDITIONING SYSTEM : Door Control

INFOID:000000011136102

DOOR MOTOR CONTROL

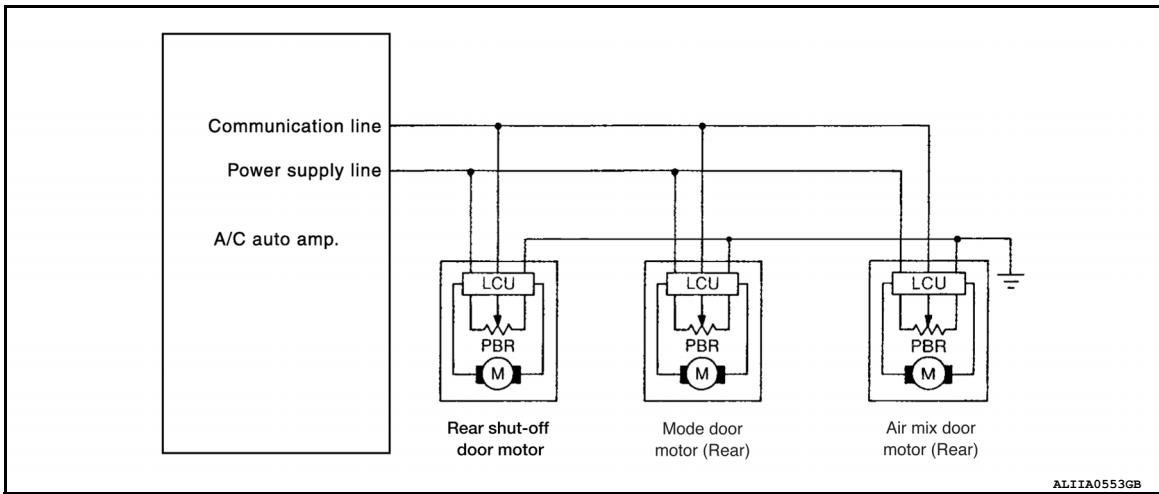

- LCU (Local Control Unit) is built in to each door motor, and detects door position by PBR (Potentiometer Balance Resistor).
- A/C auto amp. communicates with each LCU via communication line and receives each door position feedback signal from each LCU.
- Each LCU controls each door to the appropriate position depending on the control signal from A/C auto amp. when the door movement is complete, transmits the signal of door movement completion to A/C auto amp.

SWITCHES AND THEIR CONTROL FUNCTION

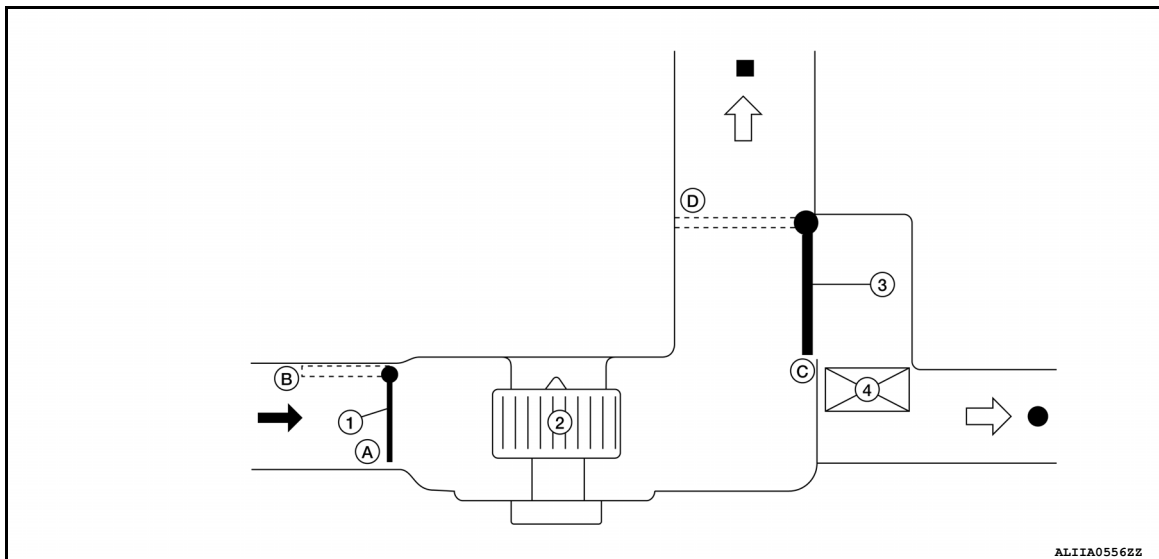

- | | | |
|-----------------------|------------------------|---------------------|
| 1. Rear shut-off door | 2. Rear blower motor 1 | 3. Mode door (rear) |
| 4. PTC heater | | |
| ← Recirculation air | ■ Rear ventilator | ● Rear A/C foot |

SYSTEM

< SYSTEM DESCRIPTION >

[AUTOMATIC AIR CONDITIONING]

Switch/Dial position		Door position		
		Mode door (rear)	Rear shut-off door	
AUTO switch	Front A/C control	☀	AUTO	B
	Rear air control	AUTO		
	VENT	↙	C	—
	FOOT	↘	D	—
OFF switch			AUTO	A

AIR DISTRIBUTION

Discharge air flow		
Mode position	Air outlet/distribution	
	VENT	FOOT
↙	100%	—
↘	—	100%

REAR AUTOMATIC AIR CONDITIONING SYSTEM : Temperature Control INFOID:000000011136103

- When ignition switch is in the ON position, A/C auto amp. always automatically controls temperature regardless of rear air conditioning operational state.
- A/C auto amp. calculates the target air mix door (rear) opening angle depending on set temperature, ambient temperature, and sunload.
- Air mix door (rear) is controlled depending on the comparison of current air mix door (rear) opening angle and target air mix door (front) opening angle.
- Regardless of ambient temperature, and sunload, air mix door (rear) is fixed at the fully cold position when set temperature is 18.0°C (60°F), and at the fully hot position when set temperature is 32.0°C (90°F).

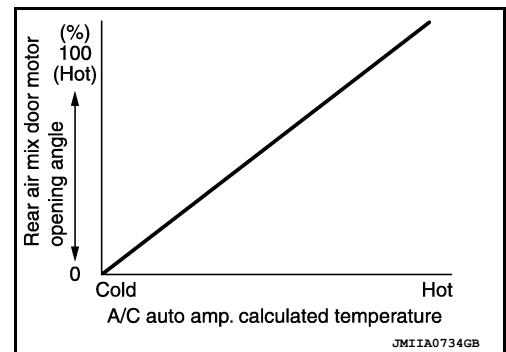

ACCS (ADVANCED CLIMATE CONTROL SYSTEM)

SYSTEM

< SYSTEM DESCRIPTION >

[AUTOMATIC AIR CONDITIONING]

ACCS (ADVANCED CLIMATE CONTROL SYSTEM) : System Diagram

INFOID:000000011136104

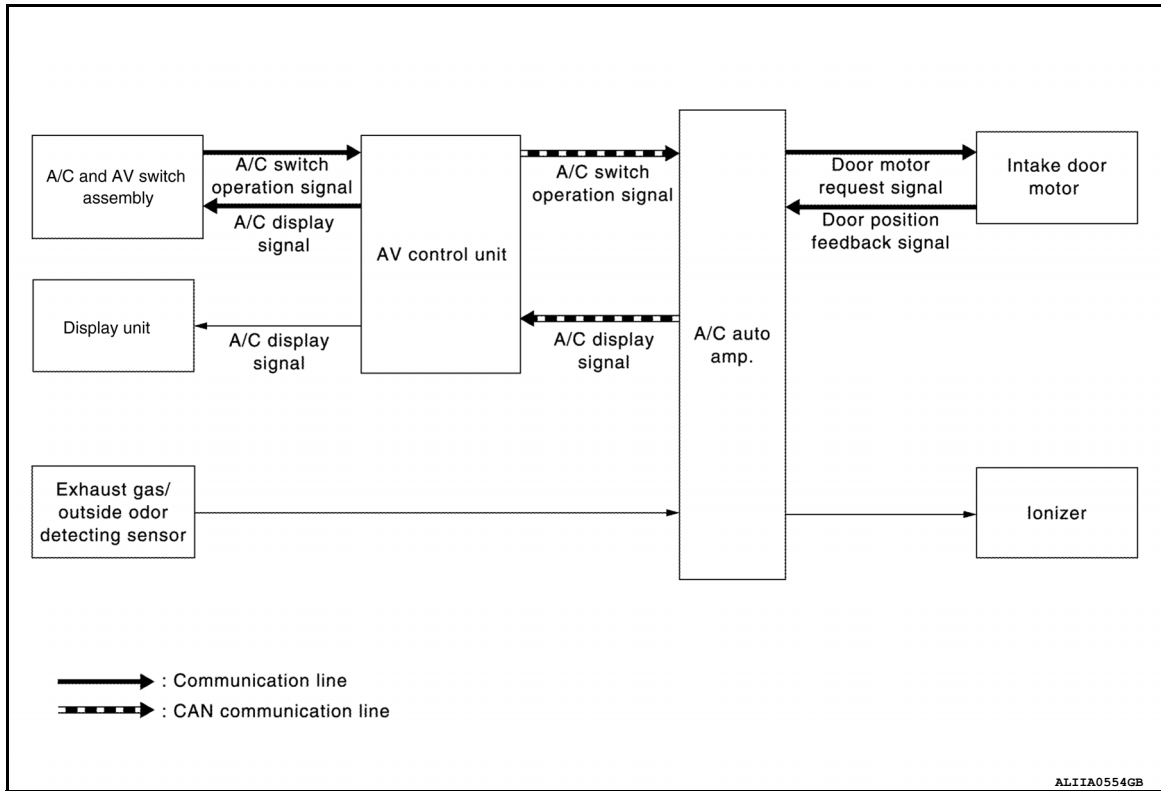

ACCS (ADVANCED CLIMATE CONTROL SYSTEM) : System Description

INFOID:000000011136105

HAC

- ACCS (advanced climate control system) controls passenger room air. It maintains the cleanliness of the passenger room air using an in-cabin microfilter and a combination of each of the following functions.
- [HAC-31. "ACCS \(ADVANCED CLIMATE CONTROL SYSTEM\) : Automatic Intake Control \(Exhaust Gas / Outside Odor Detecting Mechanism\)"](#)
- [HAC-32. "ACCS \(ADVANCED CLIMATE CONTROL SYSTEM\) : Plasmacluster Control"](#)

NOTE:

- Plasmacluster™ ion technology developed by Sharp Corporation is installed in this item.
- Plasmacluster™ is a trademark of Sharp Corporation.
- Various operations of ACCS (advanced climate control system) are transmitted from A/C and AV switch assembly to AV control unit via communication line and from AV control unit to A/C auto amp. via CAN communication. A/C auto amp. sends each indication information to AV control unit via CAN communication. AV control unit displays each indication information that is received.

ACCS (ADVANCED CLIMATE CONTROL SYSTEM) : Automatic Intake Control (Exhaust Gas / Outside Odor Detecting Mechanism)

INFOID:000000011136107

DESCRIPTION

In addition to air inlet automatic control of front automatic air conditioning system, A/C auto amp. controls automatically air inlet according to signal from exhaust gas / outside odor detecting sensor, so that unpleasant outside odor does not enter in passenger room.

OPERATION DESCRIPTION

- When pressing auto intake switch while front blower motor is operated and DEF switch is OFF, auto intake switch indicator lamp and intake switch indicator lamp turn ON. Air inlet is fixed to recirculation for approximately 5 minutes, and then is switched to automatic intake control (exhaust gas / outside odor detecting mechanism).
- Air inlet switches to recirculation when exhaust gas or outside odor is detected while automatic intake control (exhaust gas / outside odor detecting mechanism) is operated. After that, air inlet switches to fresh air intake when exhaust gas or outside odor becomes not detectable.

NOTE:

SYSTEM

< SYSTEM DESCRIPTION >

[AUTOMATIC AIR CONDITIONING]

- Sensitivity of exhaust gas / outside odor detecting sensor can be changed by "GAS SENSOR ADJUSTMENT" in "WORK SUPPORT" mode of CONSULT. Refer to [HAC-84. "ACCS \(ADVANCED CLIMATE CONTROL SYSTEM\) : Exhaust Gas / Outside Odor Detecting Sensor Sensitivity Adjustment Function"](#).
- Automatic intake control (exhaust gas / outside odor detecting mechanism) does not operate when ambient temperature is -2°C (28°F) or less. In this case, control is only for control of automatic air inlet of automatic air conditioning system.

ACCS (ADVANCED CLIMATE CONTROL SYSTEM) : Plasmacluster Control

INFOID:000000011136108

DESCRIPTION

Plasmacluster™ control eliminates microbes and reduces odor on interior surface by including high density Plasmacluster™ ion in air conditioning outlet air flow.

OPERATION DESCRIPTION

- Plasmacluster™ control operates by interlocking to blower motor. Plasmacluster™ control operates when blower motor operates.
- Control status is displayed on front air conditioning system display screen. Refer to [HAC-37. "ACCS \(ADVANCED CLIMATE CONTROL SYSTEM\) : Switch Name and Function"](#).

NOTE:

- Plasmacluster™ ion technology developed by Sharp Corporation is installed in this item.
- Plasmacluster™ is a trademark of Sharp Corporation.

OPERATION

FRONT AUTOMATIC AIR CONDITIONING SYSTEM

FRONT AUTOMATIC AIR CONDITIONING SYSTEM : Switch Name and Function

INFOID:000000011136109

A/C Display

- Front air conditioning system state is indicated on the display.
- When "STATUS" on the A/C and AV switch assembly is pressed while front air conditioning system is in the ON position, the display changes to state indication display of front air conditioning system. When front air conditioning system is operated while navigation system or audio system is displayed, front air conditioning system state is indicated in the lower portion of display for several seconds.
- When MODE switch is pressed while front air conditioning system is in the OFF position, state indication display is indicated for several seconds.

Display Screen

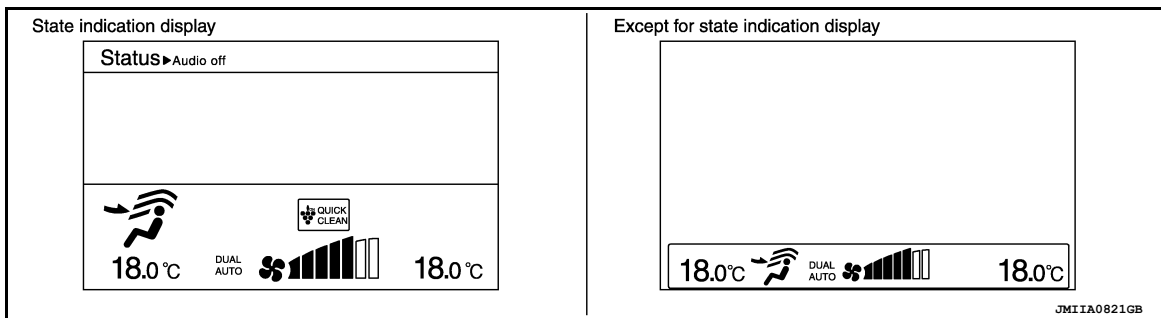

Controller (A/C and AV switch assembly)

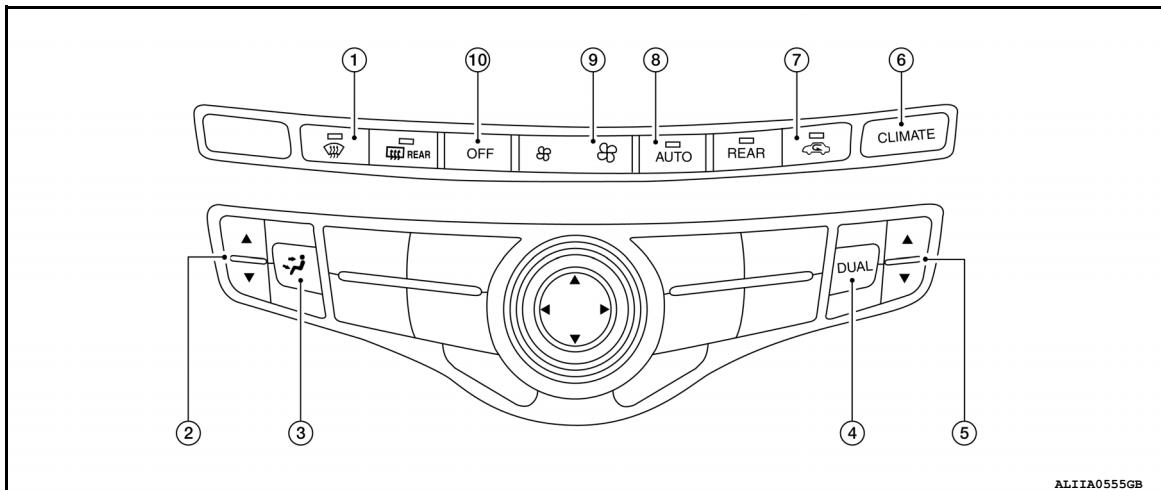

- | | | |
|------------------|--|-------------------|
| 1. DEF switch | 2. Temperature control (Driver side) | 3. MODE switch |
| 4. DUAL switch | 5. Temperature control dial (passenger side) | 6. Climate switch |
| 7. Intake switch | 8. AUTO switch | 9. Fan switch |
| 10. OFF switch | | |

Switch Operation

A
B
C
D
E
F
G
H
HAC
J
K
L
M
N
O
P

OPERATION

< SYSTEM DESCRIPTION >

[AUTOMATIC AIR CONDITIONING]

AUTO switch	<p>Turns the switch indicator lamp and "AUTO" indicator on the display ON, and then front air conditioning system becomes the following state.</p> <ul style="list-style-type: none"> • Air inlet: Automatic control • Air outlet: Automatic control • Blower fan: Automatic control • Compressor: ON
Climate switch	Turns the display unit to climate mode.
Defroster (DEF) switch	<p>Turns DEF mode (switch indicator) between ON ⇔ OFF each time.</p> <p>When DEF switch is pressed while front air conditioning system is in the ON position.</p> <ul style="list-style-type: none"> • When DEF mode is turned ON, front air conditioning system becomes the following state. <ul style="list-style-type: none"> - Air inlet: Fresh air intake - Air outlet: DEF - Blower fan: Automatic control (If fan speed other than AUTO is selected before pressing DEF switch, fan speed is manual control.) - Compressor: ON • When DEF mode is turned OFF, front air conditioning system state returns to the previous state before DEF mode is selected. But, the following state is continued. <ul style="list-style-type: none"> - Air inlet: Fresh air intake - Compressor: ON <p>When DEF switch is pressed while front air conditioning system is in the OFF position.</p> <ul style="list-style-type: none"> • When DEF mode is turned ON, front air conditioning system becomes the following state. <ul style="list-style-type: none"> - Air inlet: Fresh air intake - Air outlet: DEF - Blower fan: Automatic control - Compressor: ON • When DEF mode is turned OFF, entire front air conditioning system is set to auto mode. <p>NOTE: When DEF mode turns ON while front air conditioning system is in automatic control ("AUTO" is indicated), automatic control is released ("AUTO" turns OFF).</p>
DUAL switch	<ul style="list-style-type: none"> • Turns left and right ventilation temperature separately control (switch indicator) between ON ⇔ OFF each time. • When DUAL switch indicator is ON, the driver side and passenger side temperatures can each be set independently. • When DUAL switch indicator is OFF, the driver side outlet and setting temperature is applied to both sides. • Left and right ventilation temperature separately control is cancelled by turning the DEF mode ON. <p>NOTE: When front air conditioning system is in the OFF position, left and right ventilation temperature separately control can be selected only while front air conditioning system state (when MODE switch is pressed) is indicated on the display.</p>
Fan switch (UP/DOWN)	<p>Blower fan speed is manually controlled with these switches. Seven speeds are available for manual control (as shown on the display screen).</p> <p>NOTE:</p> <ul style="list-style-type: none"> • When fan switch is pressed while front air conditioning system is in OFF, front air conditioning system is activated. (Compressor control state returns to the previous state before front air conditioning system OFF.) • When fan switch is pressed while front air conditioning system is in automatic control ("AUTO" is indicated), automatic control is released ("AUTO" turns OFF).
MODE switch	<p>Selects air outlet sequentially from VENT ⇒ B/L ⇒ FOOT ⇒ D/F ⇒ VENT each time.</p> <p>NOTE:</p> <ul style="list-style-type: none"> • When front air conditioning system is in the OFF position, air outlet can be selected. • When MODE switch is pressed while front air conditioning system is in automatic control ("AUTO" is indicated), automatic control is released ("AUTO" turns OFF).
OFF switch	<ul style="list-style-type: none"> • Turns front air conditioning system OFF. • When front air conditioning system turns OFF, air inlet and air outlet become the automatic control.

OPERATION

< SYSTEM DESCRIPTION >

[AUTOMATIC AIR CONDITIONING]

Intake switch	<p>Air inlet changes between recirculation (REC) ⇔ fresh air intake (FRE) each time this switch is pressed.</p> <ul style="list-style-type: none"> • Intake switch indicator ON: Recirculation • Intake switch indicator OFF: Fresh air intake <p>NOTE:</p> <ul style="list-style-type: none"> • When front air conditioning system is in the OFF position, air inlet can be selected. • When MODE switch and DEF switch is in the D/F or DEF position, air inlet cannot be selected to recirculation (REC). 	A B
Temperature control switch (Driver side)	<p>Setting temperature is selected using this switch within a range between 18°C (60°F) and 32°C (90°F) at a rate of 0.5°C (1.0°F) per adjustment.</p> <ul style="list-style-type: none"> • ▲ Press: Setting temperature increases • ▼ Press: Setting temperature decreases <p>NOTE:</p> <p>When air conditioning system is OFF, setting temperature can be selected only while air conditioning system status screen [only when MODE switch (driver side) is pressed] is indicated on display.</p>	C D
Temperature control switch (Passenger side)	<ul style="list-style-type: none"> • The system is set to LH/RH independent status (“DUAL” displays) by operating this switch. Outlet air flow temperature of passenger side can be changed without changing outlet air flow temperature of driver side. • Setting temperature is selected using this switch within a range between 18°C (60°F) and 32°C (90°F) at a rate of 0.5°C (1.0°F) per adjustment. <ul style="list-style-type: none"> - ▲ Press: Setting temperature increases - ▼ Press: Setting temperature decreases <p>NOTE:</p> <ul style="list-style-type: none"> • When air conditioning system is OFF, setting temperature can be selected only while air conditioning system status screen [only when MODE switch (passenger side) is pressed] is indicated on display. • When DEF mode is ON, temperature control switch (passenger side) is inoperative. 	E F G H

REAR AUTOMATIC AIR CONDITIONING SYSTEM

REAR AUTOMATIC AIR CONDITIONING SYSTEM : Switch Name and Function

INFOID:000000011136110

FRONT CONTROLLER OPERATION

A/C Display

- Rear air conditioning system state is indicated on the display unit.
- When REAR switch is pressed while air conditioning system is in the ON position, the display unit changes to state indication display (rear control mode) of rear air conditioning system.

Display screen

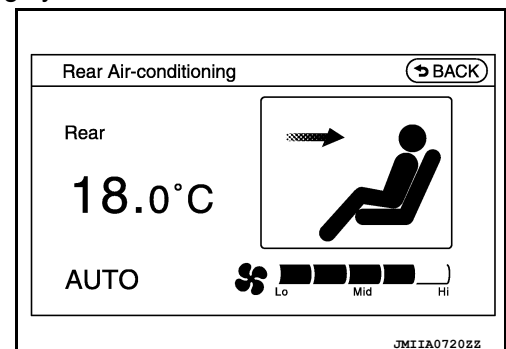

Controller (A/C and AV switch assembly)

OPERATION

< SYSTEM DESCRIPTION >

[AUTOMATIC AIR CONDITIONING]

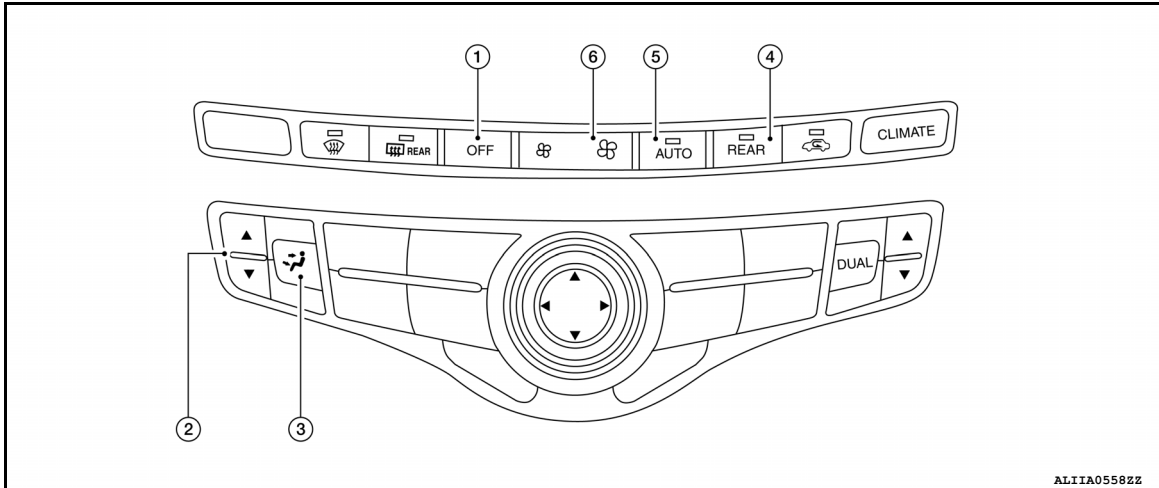

- | | | |
|----------------|--------------------------------------|----------------|
| 1. OFF switch | 2. Temperature control (Driver side) | 3. MODE switch |
| 4. REAR switch | 5. AUTO switch | 6. Fan switch |

Switch Operation

<p>AUTO switch</p>	<p>Turns the switch indicator lamp and "AUTO" indicator on the display unit ON, and then rear air conditioning system becomes the following state.</p> <ul style="list-style-type: none"> • Air outlet: Automatic control • Blower fan: Automatic control • Compressor: ON
<p>Fan switch (UP/DOWN)</p>	<p>Blower fan speed is manually controlled with these switches. Seven speeds are available for manual control (as shown on the display screen).</p> <p>NOTE: When fan switch is pressed while air conditioning system is in automatic control ("AUTO" is indicated), automatic control is released ("AUTO" turns OFF).</p>
<p>MODE switch</p>	<p>Selects air outlet sequentially from VENT ⇒ B/L ⇒ FOOT ⇒ VENT each time.</p> <p>NOTE: When MODE switch is pressed while air conditioning system is in automatic control ("AUTO" is indicated), automatic control is released ("AUTO" turns OFF).</p>
<p>OFF switch</p>	<ul style="list-style-type: none"> • Turns rear air conditioning system OFF. (When rear control mode is ON) • When rear air conditioning system turns OFF, air outlet become the automatic control.
<p>REAR switch</p>	<ul style="list-style-type: none"> • Turns the switch indicator lamp and rear control mode on the display unit ON, and then rear air conditioning system becomes the following state. - Air outlet: Automatic control - Blower fan: Automatic control - Compressor: ON • Rear control mode is released when switch is pressed again (rear air conditioning system operates continuously).
<p>Temperature control switch (Driver side)</p>	<p>Setting temperature is selected using this switch within a range between 18°C (60°F) and 32°C (90°F) at a rate of 0.5°C (1.0°F) per adjustment.</p> <ul style="list-style-type: none"> • ▲ Press: Setting temperature increases • ▼ Press: Setting temperature decreases <p>NOTE: When air conditioning system is OFF, setting temperature can be selected only while air conditioning system status screen [only when MODE switch (driver side) is pressed] is indicated on display.</p>

REAR CONTROLLER OPERATION

Controller (Rear Air Control)

OPERATION

< SYSTEM DESCRIPTION >

[AUTOMATIC AIR CONDITIONING]

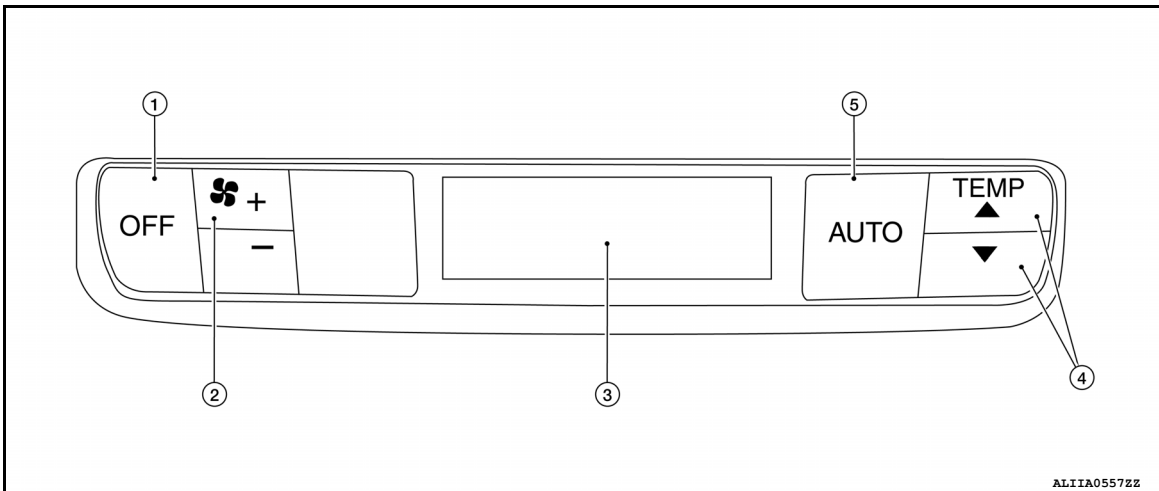

- | | | |
|-------------------------------|----------------|------------|
| 1. OFF switch | 2. Fan switch | 3. Display |
| 4. Temperature control switch | 5. AUTO switch | |

Switch Operation

AUTO switch	<p>Turns the switch indicator lamp and "AUTO" indicator on the display ON, and then rear air conditioning system becomes the following state.</p> <ul style="list-style-type: none"> • Air outlet: Automatic control • Blower fan: Automatic control • Compressor: ON
Fan switch (UP/DOWN)	<p>Blower fan speed is manually controlled with these switches. Seven speeds are available for manual control (as shown on the display screen).</p> <p>NOTE: When fan switch is pressed while air conditioning system is in automatic control ("AUTO" is indicated), automatic control is released ("AUTO" turns OFF).</p>
OFF switch	<ul style="list-style-type: none"> • Turns rear air conditioning system OFF. • When rear air conditioning system turns OFF, air outlet become the automatic control.
Temperature control switch	<p>Setting temperature is selected using this switch with in a range between 18.0°C (60°F) – 32.0°C (90°F) at a rate of 0.5°C (1°F) per adjustment.</p> <ul style="list-style-type: none"> • ▲: Press: Set temperature increases. • ▼: Press: Set temperature decreases.

ACCS (ADVANCED CLIMATE CONTROL SYSTEM)

ACCS (ADVANCED CLIMATE CONTROL SYSTEM) : Switch Name and Function

INFOID:000000011136111

OPERATION AND DISPLAY

Plasmacluster™ ion display

- Plasmacluster™ control state is indicated on the display unit.
- Plasmacluster™ ion display is switched as shown in the figure depending on air flow.

NOTE:

- Plasmacluster™ ion technology developed by Sharp Corporation is installed in this item.
- Plasmacluster™ is a trademark of Sharp Corporation.

OPERATION

< SYSTEM DESCRIPTION >

[AUTOMATIC AIR CONDITIONING]

- When air flow is small

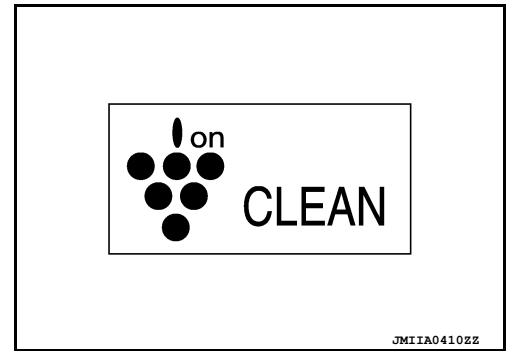

- When air flow is large

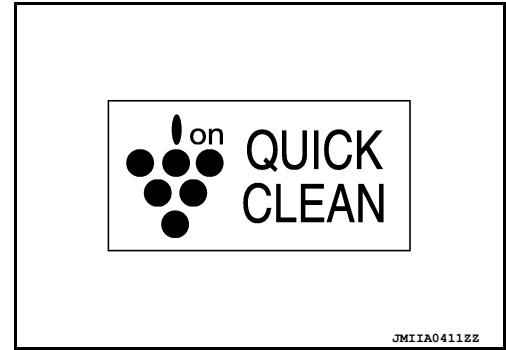

Controller (A/C and AV switch assembly)

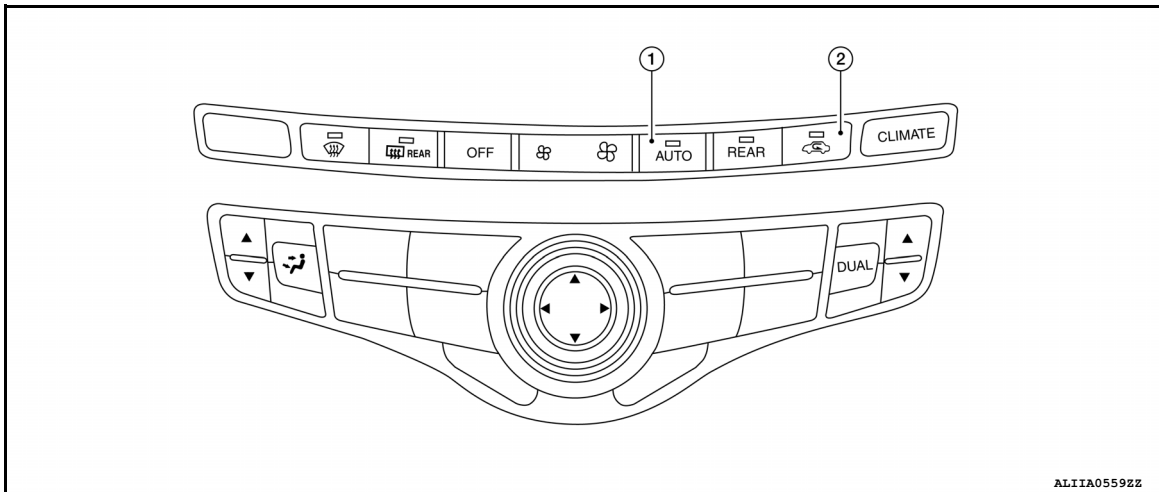

1. Auto switch

2. Intake switch

OPERATION

< SYSTEM DESCRIPTION >

[AUTOMATIC AIR CONDITIONING]

Switch name	Function
AUTO switch	Turns the switch indicator lamp and "AUTO" indicator on the display ON, and then front air conditioning system becomes the following state. <ul style="list-style-type: none"> • Air inlet: Automatic control • Air outlet: Automatic control • Blower fan: Automatic control • Compressor: ON
Intake switch	<ul style="list-style-type: none"> • Automatic intake control (exhaust gas / outside odor detecting mechanism) mode (switch indicator) changes between ON ⇔ OFF each time when auto intake switch is pressed while front blower motor is activated. • When auto intake switch turns ON, front air conditioning system becomes the following status. <ul style="list-style-type: none"> - A/C switch: ON - Air inlet: Recirculation [After approximately 5 minutes, air inlet is switched to automatic intake control (exhaust gas / outside odor detecting mechanism).] • When auto intake switch turns ON ⇒ OFF, air inlet becomes the fresh air intake. <p>NOTE:</p> <ul style="list-style-type: none"> • Interlocking condition of A/C switch can be changed. Refer to HAC-84, "ACCS (ADVANCED CLIMATE CONTROL SYSTEM) : Auto Intake Switch Interlocking Movement Change Function". • Auto intake switch does not turn ON during the following status. <ul style="list-style-type: none"> - Air outlet: DEF - Ambient temperature: -2°C (28°F) or less

A
B
C
D
E
F
G
H
J
K
L
M
N
O
P

HAC

DIAGNOSIS SYSTEM (HVAC)

< SYSTEM DESCRIPTION >

[AUTOMATIC AIR CONDITIONING]

DIAGNOSIS SYSTEM (HVAC)

Description

INFOID:000000011136112

Air conditioning system performs self-diagnosis, operation check, function diagnosis, and various settings using diagnosis function of each control unit.

ECU	Diagnostic item (CONSULT)	
A/C auto amp.	HVAC	Self Diagnostic Result
		Data Monitor
		Active Test
		Work support
AV control unit	MULTI AV	Self Diagnostic Result
	Multi AV system on board diagnosis function	
ECM	ENGINE	Self Diagnostic Result
		Data Monitor
IPDM E/R	IPDM E/R	Self Diagnostic Result
		Data Monitor
	Auto active test	

CONSULT Function

INFOID:000000011136113

CAUTION:

After disconnecting the CONSULT vehicle interface (VI) from the data link connector, the ignition must be cycled OFF → ON (for at least 5 seconds) → OFF. If this step is not performed, the BCM may not go to “sleep mode”, potentially causing a discharged battery and a no-start condition.

CONSULT performs the following functions via CAN communication with A/C auto amp.

APPLICATION ITEMS

Diagnostic mode	Description
Self Diagnostic Result	Displays the diagnosis results judged by A/C auto amp.
Data Monitor	Displays the input/output signal of A/C auto amp.
Active Test	The signals used to activate each device are forcibly supplied from A/C auto amp.
Work support	Changes the setting for each setting function.
ECU identification	Displays the part number of A/C auto amp.

NOTE:

Diagnosis should be performed with engine running. Door motor operation speeds become slower and NO results may be returned even for normal operation if battery voltage drops below 12 V during self-diagnosis.

SELF-DIAGNOSIS RESULTS

Refer to [HAC-48, "DTC Index"](#).

ACTIVE TEST

Test item	Description
HVAC TEST	The operation check of air conditioning system can be performed by selecting the mode. Refer to the following table for the conditions of each mode.

Check each output device

DIAGNOSIS SYSTEM (HVAC)

< SYSTEM DESCRIPTION >

[AUTOMATIC AIR CONDITIONING]

	Test item						
	MODE 1	MODE 2	MODE 3	MODE 4	MODE 5	MODE 6	MODE 7
Mode door motor (front) position	VENT	VENT	B/L	D/F	D/F	DEF	DEF
Intake door motor position	REC	REC	20% FRE	FRE	FRE	FRE	FRE
Air mix door motor (driver side) position	FULL COLD	FULL COLD	FULL COLD	FULL HOT	FULL HOT	FULL HOT	FULL HOT
Air mix door motor (passenger side) position	FULL COLD	FULL COLD	FULL COLD	FULL HOT	FULL HOT	FULL HOT	FULL HOT
Front blower motor control signal duty ratio	30%	30%	60%	HI	HI	60%	HI
Magnet clutch	ON	ON	ON	OFF	OFF	ON	ON
Mode door motor (rear) position	VENT	VENT	FOOT	FOOT	FOOT	FOOT	FOOT
Air mix door motor (rear) position	FULL COLD	FULL COLD	FULL COLD	FULL HOT	FULL HOT	FULL HOT	FULL HOT
Rear shut-off door motor position	FR / INT CLOSE	FR / INT CLOSE	FR / INT CLOSE	FR / INT CLOSE	FR / INT OPEN	FR / INT OPEN	FR / INT OPEN
PTC heater 1	OFF	ON	ON	ON	ON	OFF	ON
PTC heater 2	OFF	OFF	OFF	ON	ON	OFF	ON
Rear blower motor 1 control signal	3V	3V	7V	HI	HI	7V	3V
Rear blower motor 2 control signal	3V	3V	7V	HI	HI	7V	3V
Ionizer*	ON	ON	OFF	ON	ON	OFF	OFF
Display unit (Ion mode)*	CLEAN	CLEAN	OFF	QUICK CLEAN	QUICK CLEAN	OFF	OFF

*: With ACCS (advanced climate control system)

NOTE:

Perform the inspection of each output device after starting the engine because the compressor is operated.

DATA MONITOR

Display item list

Monitor item [Unit]	Description
AMB TEMP SEN [°C (°F)]	Ambient sensor value converted from ambient sensor signal received from ambient sensor.
IN-VEH TEMP [°C (°F)]	In-vehicle sensor value converted from in-vehicle sensor signal received from in-vehicle sensor.
INT TEMP SEN [°C (°F)]	Intake sensor value converted from intake sensor signal received from intake sensor.
SUNLOAD SEN [w/m ²]	Sunload sensor value converted from sunload sensor signal received from sunload sensor.
AMB SEN CAL [°C (°F)]	Ambient temperature value calculated by A/C auto amp.
IN-VEH CAL [°C (°F)]	In-vehicle temperature value calculated by A/C auto amp.
INT TEMP CAL [°C (°F)]	Front evaporator fin temperature value calculated by A/C auto amp.
SUNL SEN CAL [w/m ²]	Sunload value calculated by A/C auto amp.
COMP REQ SIG [On/Off]	Displays A/C switch ON/OFF status transmitted to other units via CAN communication.
FAN REQ SIG [On/Off]	Displays front blower motor ON/OFF status transmitted to other units via CAN communication.
FAN DUTY	Duty ratio of front blower motor judged by A/C auto amp.

DIAGNOSIS SYSTEM (HVAC)

[AUTOMATIC AIR CONDITIONING]

< SYSTEM DESCRIPTION >

Monitor item [Unit]	Description
XM	Target discharge front air temperature (driver side) judged by A/C auto amp. depending on the temperature setting and the value from each sensor.
RR XM	Target discharge rear air temperature judged by A/C auto amp. depending on the temperature setting and the value from each sensor.
PA TARGET A/TEMP	Target discharge front air temperature (passenger side) judged by A/C auto amp. depending on the temperature setting and the value from each sensor.
RRFAN REQ SIG	[On/Off] Displays rear blower motor ON/OFF status transmitted to other units via CAN communication.
RR FAN DUTY	Duty ratio of rear blower motor judged by A/C auto amp.
ENG COOL TEMP	[°C (°F)] Engine coolant temperature signal value received from ECM via CAN communication.
VEHICLE SPEED	[km/h (mph)] Vehicle speed signal value received from combination meter via CAN communication.
GAS SENSOR DETECT LEVEL	Displays value according to contamination of ambient air.
TRI ZONE XM	Target discharge tri zone air temperature judged by A/C auto amp. depending on the temperature setting and the value from each sensor.
BOOSTER FAN RQST SIGNAL	[On/Off] Displays rear blower motor ON/OFF status transmitted to other units via CAN communication.
BOOSTER FAN DUTY	Duty ratio of rear blower motor judged by A/C auto amp.

WORK SUPPORT

Work item	Description	Refer to
REAR TEMP SET CORRECT	Setting change of temperature setting trimmer (rear) can be performed.	HAC-83. "REAR AUTOMATIC AIR CONDITIONING SYSTEM : Temperature Setting Trimmer (Rear)"
TEMP SET CORRECT	Setting change of temperature setting trimmer (front) can be performed.	HAC-82. "FRONT AUTOMATIC AIR CONDITIONING SYSTEM : Temperature Setting Trimmer (Front)"
REC MEMORY SET	Setting change of inlet port memory function (REC) can be performed.	HAC-83. "FRONT AUTOMATIC AIR CONDITIONING SYSTEM : Inlet Port Memory Function (REC)"
FRE MEMORY SET	Setting change of inlet port memory function (FRE) can be performed.	HAC-83. "FRONT AUTOMATIC AIR CONDITIONING SYSTEM : Inlet Port Memory Function (FRE)"
BLOW SET	Setting change of foot position setting trimmer can be performed.	HAC-82. "FRONT AUTOMATIC AIR CONDITIONING SYSTEM : Foot Position Setting Trimmer"
GAS SENSOR ADJUSTMENT*	Setting change of exhaust gas / outside odor detecting sensor sensitivity adjustment function can be performed.	HAC-84. "ACCS (ADVANCED CLIMATE CONTROL SYSTEM) : Exhaust Gas / Outside Odor Detecting Sensor Sensitivity Adjustment Function"
CLEAN SW SET*	Setting change of auto intake switch interlocking movement change function can be performed.	HAC-84. "ACCS (ADVANCED CLIMATE CONTROL SYSTEM) : Auto Intake Switch Interlocking Movement Change Function"

DIAGNOSIS SYSTEM (HVAC)

[AUTOMATIC AIR CONDITIONING]

< SYSTEM DESCRIPTION >

*: With ACCS (advanced climate control system)

NOTE:

When the battery cable is disconnected from the negative terminal or when the battery voltage becomes 10 V or less, the setting of WORK SUPPORT may be cancelled.

- A
- B
- C
- D
- E
- F
- G
- H
- HAC**
- J
- K
- L
- M
- N
- O
- P

A/C AUTO AMP.

< ECU DIAGNOSIS INFORMATION >

[AUTOMATIC AIR CONDITIONING]

ECU DIAGNOSIS INFORMATION

A/C AUTO AMP.

Reference Value

INFOID:0000000011136114

VALUES ON THE DIAGNOSIS TOOL

Monitor item	Condition		Value/Status
AMB TEMP SEN	Ignition switch ON	—	Equivalent to ambient temperature
IN-VEH TEMP	Ignition switch ON	—	Equivalent to in-vehicle temperature (front side)
INT TEMP SEN	Ignition switch ON	—	Equivalent to front evaporator fin temperature
SUNLOAD SEN	Ignition switch ON	—	Equivalent to sunload (driver side)
AMB SEN CAL	Ignition switch ON	—	Equivalent to ambient temperature
IN-VEH CAL	Ignition switch ON	—	Equivalent to in-vehicle temperature (front side)
INT TEMP CAL	Ignition switch ON	—	Equivalent to front evaporator fin temperature
SUNL SEN CAL	Ignition switch ON	—	Equivalent to sunload (driver side)
COMP REQ SIG	Engine: Run at idle after warming up	A/C switch: ON (Compressor operation status)	On
		A/C switch: OFF	Off
FAN REQ SIG	Engine: Run at idle after warming up	Front blower motor: ON	On
		Front blower motor: OFF	Off
FAN DUTY	Engine: Run at idle after warming up	Front blower motor: ON	25 – 81
		Front blower motor: OFF	0
XM	Ignition switch ON	—	Value according to target air flow temperature (driver side)
RR XM	Ignition switch ON	—	Value according to target air flow temperature (rear side)
PA TARGET A/TEMP	Ignition switch ON	—	Value according to target air flow temperature (passenger side)
RRFAN REQ SIG	Engine: Run at idle after warming up	Rear blower motor: ON	On
		Rear blower motor: OFF	Off
RR FAN DUTY	Engine: Run at idle after warming up	Rear blower motor: ON	25 – 81
		Rear blower motor: OFF	0
ENG COOL TEMP	Ignition switch ON	—	Equivalent to engine coolant temperature
VEHICLE SPEED	Driving	—	Equivalent to speedometer reading
GAS SENSOR DETECT LEVEL	Ignition switch ON	—	Value according to contamination of ambient air
TRI ZONE XM	Ignition switch ON	—	Value according to target air flow temperature (rear side)

A/C AUTO AMP.

< ECU DIAGNOSIS INFORMATION >

[AUTOMATIC AIR CONDITIONING]

Monitor item	Condition		Value/Status
BOOSTER FAN RQST SIGNAL	Engine: Run at idle after warming up	Rear blower motor: ON	On
		Rear blower motor: OFF	Off
BOOSTER FAN DUTY	Engine: Run at idle after warming up	Rear blower motor: ON	25 – 81
		Rear blower motor: OFF	0

TERMINAL LAYOUT

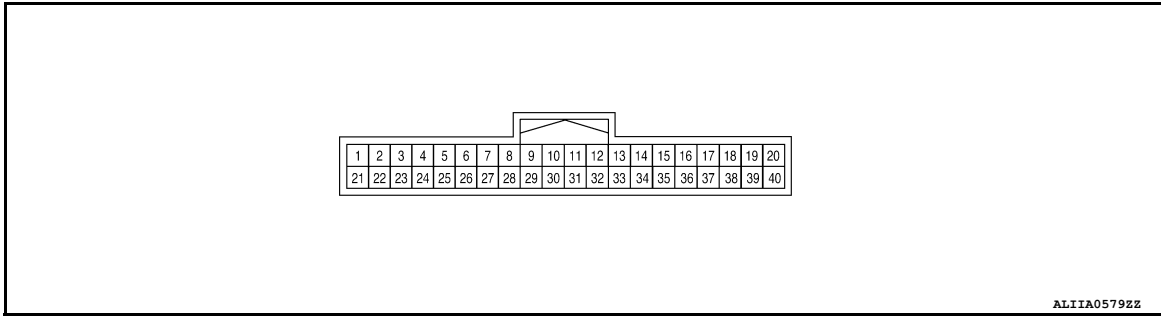

PHYSICAL VALUES

Terminal No. (Wire color)		Description		Condition	Value (Approx.)
+	-	Signal name	Input/ Output		
1 (L)	—	CAN-H	Input/ Output	—	—
2 (GR)	—	Ground	—	—	—
3 (G)	Ground	Battery power supply	Input	Ignition switch OFF	Battery voltage
5 (G)	Ground	Communication signal (A/C auto amp. → Rear air control)	Output	Ignition switch ON	
7 (G)	Ground	Ambient sensor signal	Input	Ignition switch ON	0 – 4.8 V Output voltage varies with ambient temperature
8*2 (G)	Ground	Heated steering wheel switch signal	Input	Ignition switch ON	0 V
				Other than the above	12 V
9 (W)	Ground	Sunload sensor signal	Input	Ignition switch ON	0 – 4.8 V Output voltage varies with sunload amount
10 (SB)	Ground	Drive mode select switch (SNOW) signal	Input	• Ignition switch ON • Drive mode select switch position: SNOW	0 V
				Other than the above	12 V

A/C AUTO AMP.

< ECU DIAGNOSIS INFORMATION >

[AUTOMATIC AIR CONDITIONING]

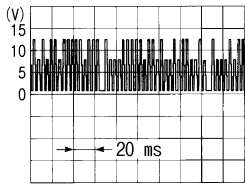
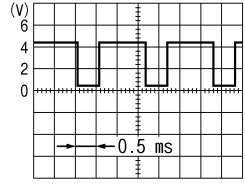
Terminal No. (Wire color)		Description		Condition	Value (Approx.)	
+	-	Signal name	Input/ Output			
11 (G)	Ground	Drive mode select switch (STANDARD) signal	Input	<ul style="list-style-type: none"> • Ignition switch ON • Drive mode select switch position: STANDARD 	0 V	
				Other than the above	12 V	
12 (G)	Ground	Fan control amp. control signal	Output	<ul style="list-style-type: none"> • Ignition switch ON • Blower speed: OFF 	0 V	
				<ul style="list-style-type: none"> • Ignition switch ON • Blower speed: 1st - 23rd 	2.5 - 3.5 V	
				<ul style="list-style-type: none"> • Ignition switch ON • Blower speed: 24th - 25th 	10 V	
13 (W)	Ground	IGN 2	Input	Ignition switch ON	Battery voltage	
14 (W)	Ground	Fan control amp. control signal	Output	<ul style="list-style-type: none"> • Ignition switch ON • Blower speed: OFF 	0 V	
				<ul style="list-style-type: none"> • Ignition switch ON • Blower speed: 1st - 23rd 	2.5 - 3.5 V	
				<ul style="list-style-type: none"> • Ignition switch ON • Blower speed: 24th - 25th 	10 V	
16 (Y)	Ground	Each door motor LIN signal	Input/ Output	Ignition switch ON	 <p style="text-align: right; font-size: small;">SJIA1453J</p>	
17 (LG)	Ground	Each door motor power supply	Output	Ignition switch ON	12 V	
18 (W)	Ground	Front blower motor control signal	Output	<ul style="list-style-type: none"> • Ignition switch ON • Front fan speed: 1st speed (manual) 	 <p style="text-align: right; font-size: small;">JSIIA0096ZZ</p>	
19 (W)	Ground	PTC1 relay output signal	Input	Ignition switch ON	PTC heater: ON	0 V
				Ignition switch OFF	PTC heater: OFF	12 V
20*2 (BR)	Ground	Heated steering wheel relay control signal	Output	Ignition switch ON	Within 30 seconds after turning ON the heated steering switch.	0 V
				Other than the above		12 V
21 (P)	—	CAN-L	Input/ Output	—	—	

A/C AUTO AMP.

< ECU DIAGNOSIS INFORMATION >

[AUTOMATIC AIR CONDITIONING]

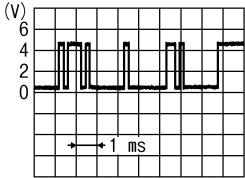
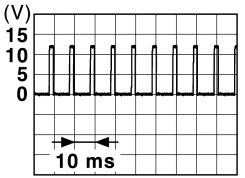
Terminal No. (Wire color)		Description		Condition	Value (Approx.)
+	-	Signal name	Input/ Output		
22 (GR)	—	Ground	—	—	—
23 (LG)	Ground	Ignition power supply	Input	Ignition switch ON	Battery voltage
25 (W)	Ground	Communication signal (Rear air control→A/C auto amp.)	Input	Ignition switch ON	 <p style="text-align: right; font-size: small;">SJIA1522J</p>
26 (G)	—	Sensor ground	—	—	—
27 (W)	Ground	In-vehicle sensor signal	Input	Ignition switch ON	0 – 4.8 V Output voltage varies with in-vehicle temperature
28 (W)	Ground	Intake sensor signal	Input	Ignition switch ON	0 – 4.8 V Output voltage varies with front evaporator fin temperature
29 (P)	Ground	Drive mode select switch (ECO) signal	Input	<ul style="list-style-type: none"> Ignition switch ON Drive mode select switch position: ECO 	0 V
				Other than the above	12 V
30*1 (R)	Ground	Exhaust gas / outside odor detecting sensor signal	Input	<ul style="list-style-type: none"> Ignition switch ON <p>NOTE: The signal is depending on measurement environment of the vehicle</p>	 <p style="text-align: right; font-size: small;">JM1IA2115GB</p>
31 (BG)	Ground	Drive mode select switch (SPORT) signal	Input	<ul style="list-style-type: none"> Ignition switch ON Drive mode select switch position: SPORT 	0 V
				Other than the above	12 V
32 (L)	Ground	Blower motor feedback	Input	<ul style="list-style-type: none"> Ignition switch ON Blower speed: OFF 	Battery voltage
				<ul style="list-style-type: none"> Ignition switch ON Blower speed: 1st 	10 V
				<ul style="list-style-type: none"> Ignition switch ON Blower speed: 25th 	0 V
34 (L)	Ground	Blower motor feedback	Input	<ul style="list-style-type: none"> Ignition switch ON Blower speed: OFF 	Battery voltage
				<ul style="list-style-type: none"> Ignition switch ON Blower speed: 1st 	10 V
				<ul style="list-style-type: none"> Ignition switch ON Blower speed: 25th 	0 V
37 (BR)	—	Ground	—	—	—

A
B
C
D
E
F
G
H

HAC

J
K
L
M

N
O

P

A/C AUTO AMP.

< ECU DIAGNOSIS INFORMATION >

[AUTOMATIC AIR CONDITIONING]

Terminal No. (Wire color)		Description		Condition		Value (Approx.)
+	-	Signal name	Input/ Output			
38*1 (P)	Ground	Ionizer (ON/OFF) control signal	Output	Ignition switch ON	Front blower motor: ON	0 V
					Front blower motor: OFF	12 V
39 (L)	Ground	PTC2 relay output signal	Input	Ignition switch ON	PTC heater: ON	0 V
					PTC heater: OFF	12 V

*1: With ACCS (advanced climate control system)

*2: With heated steering wheel

Fail-safe

INFOID:0000000011136115

FAIL-SAFE FUNCTION

If a communication error exists between the A/C auto amp., and the AV control unit and preset switch for 30 seconds or longer, air conditioning is controlled under the following conditions:

When ambient temperature is less than 3°C (37°F) and engine coolant temperature is less than 56°C (133°F)

Compressor : ON
Air outlet : DEF
Air inlet : FRE (Fresh air intake)
Blower fan speed : AUTO
Set temperature : Setting before communication error occurs

When ambient temperature is 3°C (37°F) or more, or engine coolant temperature is 56°C (133°F) or more

Compressor : ON
Air outlet : AUTO
Air inlet : 20% FRE (20% fresh air intake)
Blower fan speed : AUTO
Set temperature : Setting before communication error occurs

DTC Index

INFOID:0000000011136116

DTC	Items (CONSULT screen terms)	Reference
U1000	CAN COMM CIRCUIT	HAC-86, "DTC Logic"
U1010	CONTROL UNIT (CAN)	HAC-87, "DTC Logic"
B2578	IN-VEHICLE SENSOR	HAC-88, "DTC Logic"
B2579	IN-VEHICLE SENSOR	HAC-88, "DTC Logic"
B257B	AMBIENT SENSOR	HAC-91, "DTC Logic"
B257C	AMBIENT SENSOR	HAC-91, "DTC Logic"
B2581	INTAKE SENSOR	HAC-94, "DTC Logic"
B2582	INTAKE SENSOR	HAC-94, "DTC Logic"
B262A*1	GAS SENSOR	HAC-97, "DTC Logic"
B262B*1	GAS SENSOR	HAC-97, "DTC Logic"
B2630*2	SUNLOAD SENSOR	HAC-100, "DTC Logic"
B2631*2	SUNLOAD SENSOR	HAC-100, "DTC Logic"

A/C AUTO AMP.

< ECU DIAGNOSIS INFORMATION >

[AUTOMATIC AIR CONDITIONING]

DTC	Items (CONSULT screen terms)	Reference
B2632	DR AIR MIX DOOR MOT	HAC-103, "DTC Logic"
B2633	DR AIR MIX DOOR MOT	HAC-103, "DTC Logic"
B2634	PASS AIR MIX DOOR MOT	HAC-105, "DTC Logic"
B2635	PASS AIR MIX DOOR MOT	HAC-105, "DTC Logic"
B2636	DR VENT DOOR FAIL	HAC-107, "DTC Logic"
B2637	DR B/L DOOR FAIL	HAC-107, "DTC Logic"
B2638	DR D/F1 DOOR FAIL	HAC-107, "DTC Logic"
B2639	DR DEF DOOR FAIL	HAC-107, "DTC Logic"
B263D	FRE DOOR FAIL	HAC-109, "DTC Logic"
B263E	20P FRE DOOR FAIL	HAC-109, "DTC Logic"
B263F	REC DOOR FAIL	HAC-109, "DTC Logic"
B2654	D/F2 DOOR FAIL	HAC-107, "DTC Logic"
B2657* ¹	GAS SENSOR CIRCUIT	HAC-97, "DTC Logic"
B2658* ¹	GAS SENSOR CIRCUIT	HAC-97, "DTC Logic"
B2796	COMMUNICATION ERROR	HAC-111, "DTC Logic"
B2797	COMMUNICATION ERROR	HAC-111, "DTC Logic"
B2798	COMMUNICATION ERROR	HAC-111, "DTC Logic"
B2799	REAR AIR MIX DOOR MOT	HAC-111, "DTC Logic"
B279A	REAR AIR MIX DOOR MOT	HAC-111, "DTC Logic"
B279B	REAR MODE DOOR MOT	HAC-113, "DTC Logic"
B279C	REAR MODE DOOR MOT	HAC-113, "DTC Logic"
B279D	REAR SHUT-OFF DOOR MOT	HAC-113, "DTC Logic"
B279E	REAR SHUT-OFF DOOR MOT	HAC-113, "DTC Logic"
B27B0	A/C AUTO AMP.	HAC-119, "DTC Logic"

*1: With ACCS (advanced climate control system)

*2: Perform self-diagnosis under sunshine. When performing indoors, aim a light (more than 60 W) at sunload sensor, otherwise self-diagnosis indicates even though the sunload sensor is functioning normally.

NOTE:

If all of door motor DTCs (B2632, B2633, B2634, B2635, B2636, B2637, B2638, B2639, B263D, B263E, B263F, B2654, B2799, B279A, B279B, B279C, B279D, and B279E) are detected, check door motor communication circuit. Refer to [HAC-131, "Diagnosis Procedure"](#).

ECM, IPDM E/R, BCM

< ECU DIAGNOSIS INFORMATION >

[AUTOMATIC AIR CONDITIONING]

ECM, IPDM E/R, BCM

List of ECU Reference

INFOID:0000000011136117

ECU	Reference
ECM	EC-618, "Reference Value" (except for Mexico) or EC-92, "Reference Value" (for Mexico)
	EC-618, "Reference Value" (except for Mexico) or EC-618, "Reference Value" (for Mexico)
	EC-634, "DTC Inspection Priority Chart" (except for Mexico) or EC-634, "DTC Inspection Priority Chart" (for Mexico)
	EC-636, "DTC Index" (except for Mexico) or EC-636, "DTC Index" (for Mexico)
IPDM E/R	PCS-12, "Reference Value"
	PCS-19, "Fail Safe"
	PCS-20, "DTC Index"
BCM	BCS-29, "Reference Value"
	BCS-49, "Fail Safe"
	BCS-49, "DTC Inspection Priority Chart"
	BCS-51, "DTC Index"

AUTOMATIC AIR CONDITIONING SYSTEM

[AUTOMATIC AIR CONDITIONING]

< WIRING DIAGRAM >

WIRING DIAGRAM

AUTOMATIC AIR CONDITIONING SYSTEM

Wiring Diagram

INFOID:000000011136118

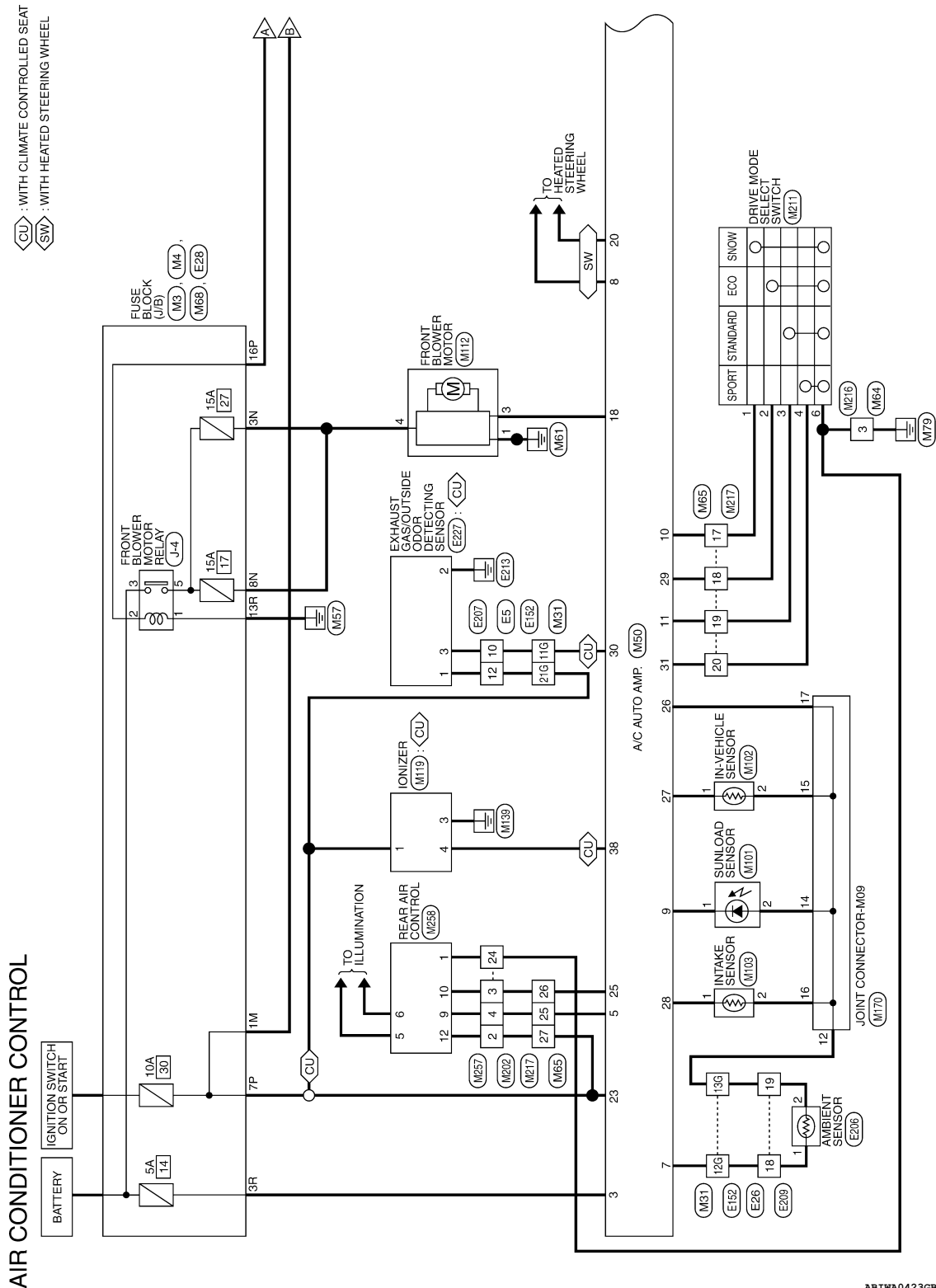

ABIWA0423GB

A
B
C
D
E
F
G
H
I
J
K
L
M
N
O
P

HAC

AUTOMATIC AIR CONDITIONING SYSTEM

[AUTOMATIC AIR CONDITIONING]

< WIRING DIAGRAM >

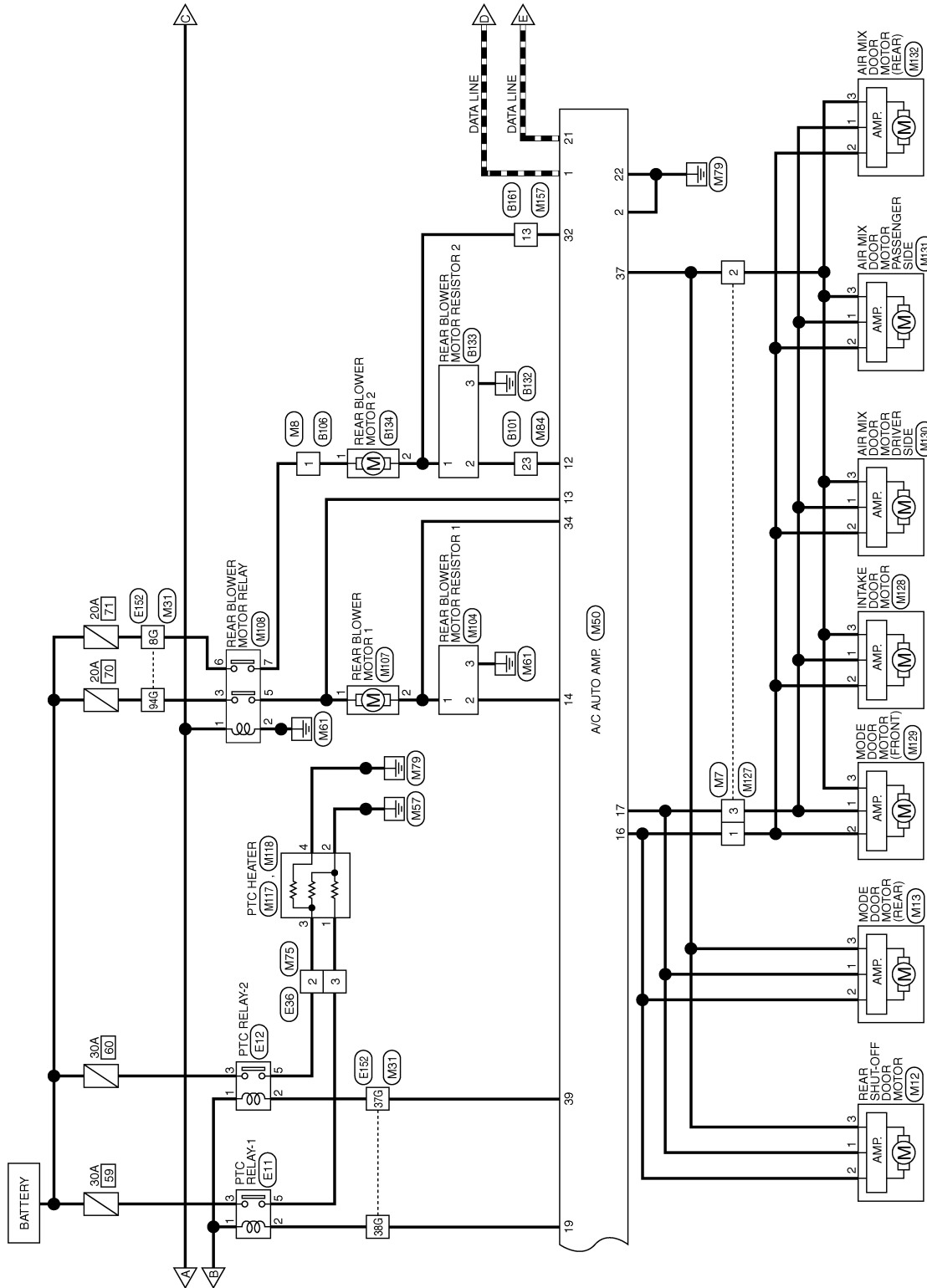

ABIWA0454GB

AUTOMATIC AIR CONDITIONING SYSTEM

[AUTOMATIC AIR CONDITIONING]

< WIRING DIAGRAM >

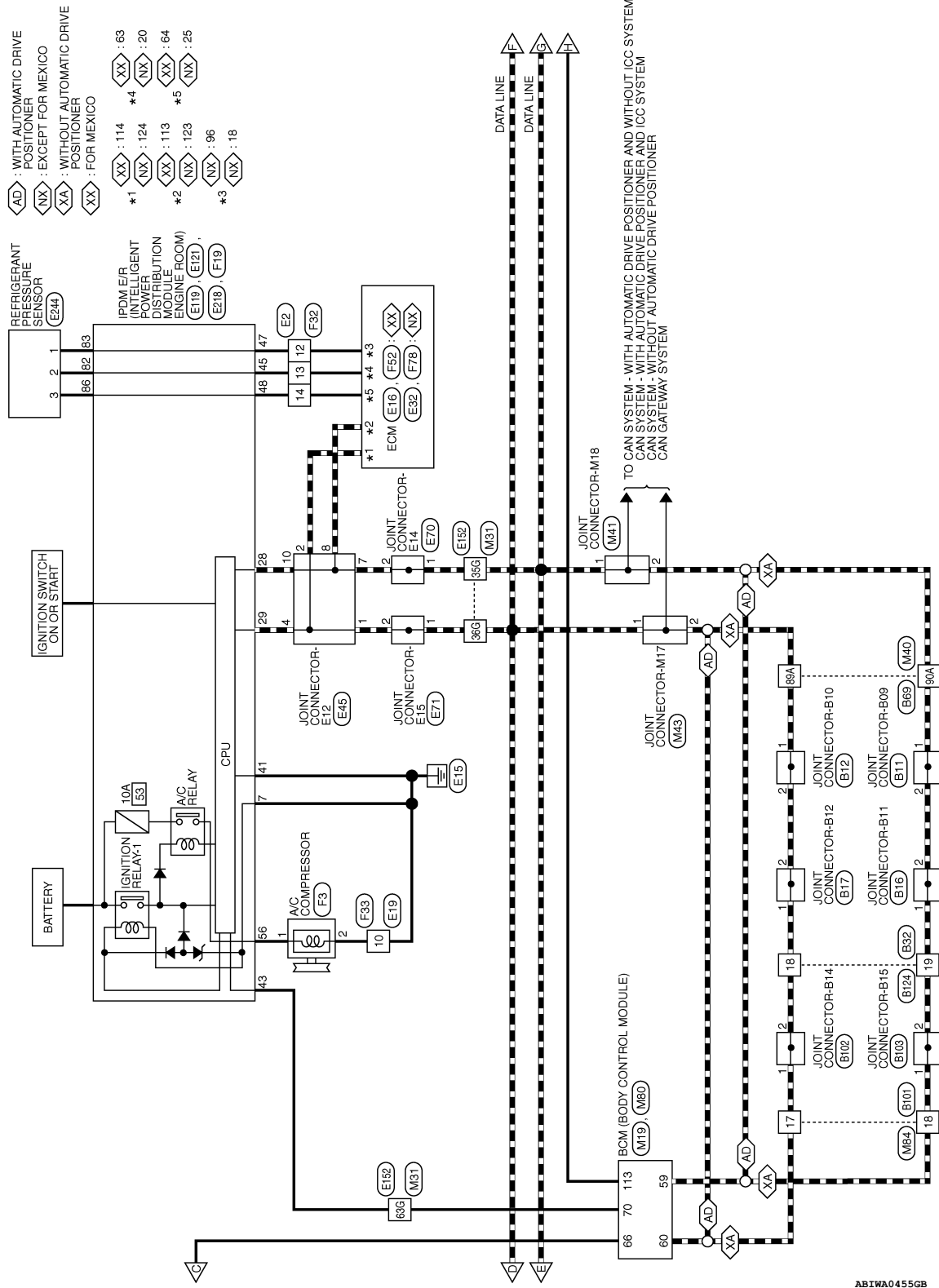

ABIWA0455GB

A
B
C
D
E
F
G
H
HAC
J
K
L
M
N
O
P

AUTOMATIC AIR CONDITIONING SYSTEM

< WIRING DIAGRAM >

[AUTOMATIC AIR CONDITIONING]

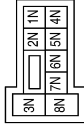

AIR CONDITIONER CONTROL CONNECTORS

Connector No.	M3
Connector Name	FUSE BLOCK (J/B)
Connector Color	WHITE

Terminal No.	Color of Wire	Signal Name
3N	L	-
8N	L	-

Connector No.	M4
Connector Name	FUSE BLOCK (J/B)
Connector Color	WHITE



Terminal No.	Color of Wire	Signal Name
7P	LG	-
16P	W	-

Connector No.	M7
Connector Name	WIRE TO WIRE
Connector Color	WHITE

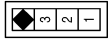
Terminal No.	Color of Wire	Signal Name
1	Y	-
2	BR	-
3	LG	-

Connector No.	M8
Connector Name	WIRE TO WIRE
Connector Color	GRAY

Terminal No.	Color of Wire	Signal Name
1	V	-

Connector No.	M12
Connector Name	REAR SHUT-OFF DOOR MOTOR
Connector Color	WHITE

Terminal No.	Color of Wire	Signal Name
1	LG	-
2	Y	-
3	BR	-

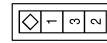
Connector No.	M13
Connector Name	MODE DOOR MOTOR (REAR)
Connector Color	WHITE

Terminal No.	Color of Wire	Signal Name
1	LG	-
2	Y	-
3	BR	-

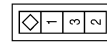
ABI1A1126GB

A
B
C
D
E
F
G
H
HAC
J
K
L
M
N
O
P

AUTOMATIC AIR CONDITIONING SYSTEM

< WIRING DIAGRAM >

[AUTOMATIC AIR CONDITIONING]

Terminal No.	Color of Wire	Signal Name
3G	P	-
8G	G	-
11G	R	-
12G	G	-
13G	G	-
21G	R	-
35G	P	-
36G	L	-
37G	L	-
38G	W	-
50G	L	-
63G	P	-
94G	O	-

Connector No.	M31
Connector Name	WIRE TO WIRE
Connector Color	WHITE

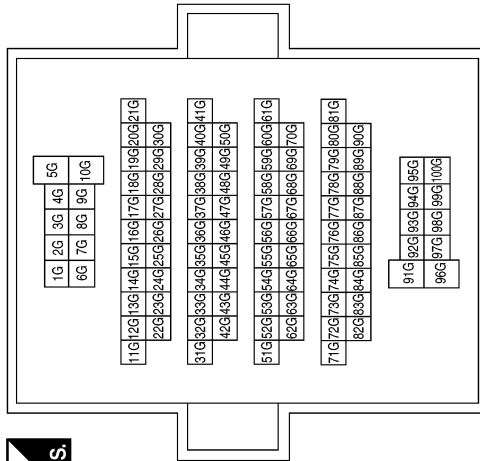

Connector No.	M19
Connector Name	BCM (BODY CONTROL MODULE)
Connector Color	BLACK

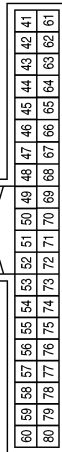

Terminal No.	Color of Wire	Signal Name
59	P	CAN-L
60	L	CAN-H
66	W	BLOWER FAN RELAY OUT
70	P	IGN USM OUT1

ABIIA0870GB

AUTOMATIC AIR CONDITIONING SYSTEM

< WIRING DIAGRAM >

[AUTOMATIC AIR CONDITIONING]

Connector No.	M41
Connector Name	JOINT CONNECTOR-M18
Connector Color	WHITE



Terminal No.	Color of Wire	Signal Name
1	P	-
2	P	-

Terminal No.	Color of Wire	Signal Name
89A	L	-
90A	P	-

Connector No.	M40
Connector Name	WIRE TO WIRE
Connector Color	GRAY

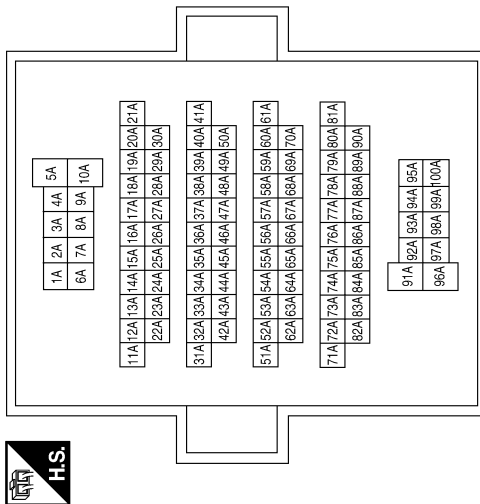

Connector No.	M45
Connector Name	AV CONTROL UNIT (WITH BASE AUDIO SYSTEM)
Connector Color	WHITE

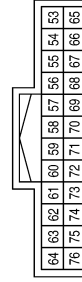

Terminal No.	Color of Wire	Signal Name
61	B	DISP IT
72	SHIELD	SHIELD
73	W	IT DISP

Connector No.	M43
Connector Name	JOINT CONNECTOR-M17
Connector Color	WHITE

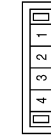

Terminal No.	Color of Wire	Signal Name
1	L	-
2	L	-

Connector No.	M42
Connector Name	AV CONTROL UNIT (WITH BASE AUDIO SYSTEM)
Connector Color	WHITE

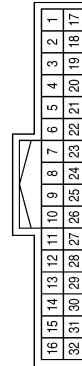

Terminal No.	Color of Wire	Signal Name
11	L	CAN-H
12	P	CAN-L
13	SB	M-CAN1 H
14	LG	M-CAN1 L

ABI1A1127GB

A
B
C
D
E
F
G
H
HAC
J
K
L
M
N
O
P

AUTOMATIC AIR CONDITIONING SYSTEM

< WIRING DIAGRAM >

[AUTOMATIC AIR CONDITIONING]

Terminal No.	Color of Wire	Signal Name
25	W	RX RR
26	G	SENS GND
27	W	INC SENS
28	W	INT SENS
29	P	MODE2
30	R	GAS SENS
31	BG	MODE4
32	L	FAN F/B (COOLER)
33	-	-
34	L	FAN F/B (BOOSTER)
35	-	-
36	-	-
37	BR	ACTR GND
38	P	ION ON/OFF
39	L	PTC2
40	-	-

Terminal No.	Color of Wire	Signal Name
8	G	STRG HTR SW
9	W	SUN SENS
10	SB	MODE1
11	G	MODE3
12	G	FAN OUT (COOLER)
13	W	IGN2
14	W	FAN OUT (BOOSTER)
15	-	-
16	Y	ACTR (LIN)
17	LG	VACTR
18	W	FR FAN PWM
19	W	PTC1
20	BR	STRG HTR RLY
21	P	CAN-L
22	GR	GND (POWER)
23	LG	IGN
24	-	-

Connector No.	M50
Connector Name	A/C AUTO AMP.
Connector Color	WHITE



1	2	3	4	5	6	7	8	9	10	11	12	13	14	15	16	17	18	19	20
21	22	23	24	25	26	27	28	29	30	31	32	33	34	35	36	37	38	39	40

Terminal No.	Color of Wire	Signal Name
1	L	CAN-H
2	GR	GND
3	G	BATT
4	-	-
5	G	TX RR
6	-	-
7	G	AMB SENS

Connector No.	M68
Connector Name	FUSE BLOCK (J/B)
Connector Color	BROWN



7R	8R	5R	4R	4R	3R	2R	1R	
16R	15R	14R	13R	12R	11R	10R	9R	8R

Connector No.	M65
Connector Name	WIRE TO WIRE
Connector Color	WHITE



16	15	14	13	12	11	10	9	8	7	6	5	4	3	2	1
32	31	30	29	28	27	26	25	24	23	22	21	20	19	18	17

Connector No.	M64
Connector Name	WIRE TO WIRE
Connector Color	WHITE



7	6	5	4	3	2	1		
16	15	14	13	12	11	10	9	8

Terminal No.	Color of Wire	Signal Name
3R	G	-
13R	GR	-

Terminal No.	Color of Wire	Signal Name
17	SB	-
18	P	-
19	G	-
20	BG	-
25	G	-
26	W	-
27	LG	-

Terminal No.	Color of Wire	Signal Name
3	B	-

ABIIA0872GB

AUTOMATIC AIR CONDITIONING SYSTEM

< WIRING DIAGRAM >

[AUTOMATIC AIR CONDITIONING]

Connector No.	M84
Connector Name	WIRE TO WIRE
Connector Color	WHITE

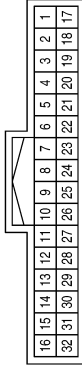
Terminal No.	Color of Wire	Signal Name
17	L	-
18	P	-
23	G	-

Connector No.	M80
Connector Name	BCM (BODY CONTROL MODULE)
Connector Color	BLACK

Terminal No.	Color of Wire	Signal Name
113	L	ACC RELAY OUT

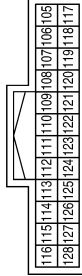
Connector No.	M75
Connector Name	WIRE TO WIRE
Connector Color	WHITE

Terminal No.	Color of Wire	Signal Name
2	G	-
3	W	-

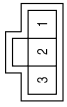
Connector No.	M98
Connector Name	A/C AND AV SWITCH ASSEMBLY
Connector Color	WHITE

Terminal No.	Color of Wire	Signal Name
1	GR	-
3	P	-
6	SB	-
8	LG	-

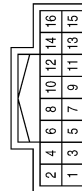
Connector No.	M93
Connector Name	DISPLAY UNIT (WITHOUT NAVI)
Connector Color	WHITE

Terminal No.	Color of Wire	Signal Name
11	W	UART IN
22	B	UART OUT
23	SHIELD	UART GND

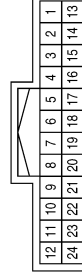
Connector No.	M92
Connector Name	DISPLAY UNIT (WITH NAVI)
Connector Color	WHITE

Terminal No.	Color of Wire	Signal Name
9	B	FRONT DISP IT
10	W	IT FRONT DISP
22	SHIELD	SHIELD

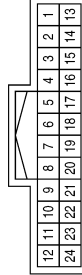
ABIIA1128GB

A
B
C
D
E
F
G
H
HAC
J
K
L
M
N
O
P

AUTOMATIC AIR CONDITIONING SYSTEM

[AUTOMATIC AIR CONDITIONING]

< WIRING DIAGRAM >

Connector No.	M103
Connector Name	INTAKE SENSOR
Connector Color	WHITE



Terminal No.	Color of Wire	Signal Name
1	W	-
2	G	-

Connector No.	M102
Connector Name	IN-VEHICLE SENSOR
Connector Color	WHITE



Terminal No.	Color of Wire	Signal Name
1	W	-
2	G	-

Connector No.	M101
Connector Name	SUNLOAD SENSOR
Connector Color	BLACK



Terminal No.	Color of Wire	Signal Name
1	W	-
2	G	-

Connector No.	M108
Connector Name	REAR BLOWER MOTOR RELAY
Connector Color	BROWN



Terminal No.	Color of Wire	Signal Name
1	W	-
2	GR	-
3	O	-
5	W	-
6	G	-
7	V	-

Connector No.	M107
Connector Name	REAR BLOWER MOTOR 1
Connector Color	WHITE



Terminal No.	Color of Wire	Signal Name
1	W	-
2	L	-

Connector No.	M104
Connector Name	REAR BLOWER MOTOR RESISTOR 1
Connector Color	WHITE



Terminal No.	Color of Wire	Signal Name
1	L	-
2	W	-
3	B	-

ABIIA0874GB

AUTOMATIC AIR CONDITIONING SYSTEM

< WIRING DIAGRAM >

[AUTOMATIC AIR CONDITIONING]

Connector No.	M118
Connector Name	PTC HEATER
Connector Color	WHITE

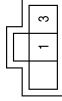

Terminal No.	Color of Wire	Signal Name
1	W	-
3	G	-

Connector No.	M117
Connector Name	PTC HEATER
Connector Color	WHITE



Terminal No.	Color of Wire	Signal Name
2	GR	-
4	B	-

Connector No.	M112
Connector Name	FRONT BLOWER MOTOR
Connector Color	WHITE

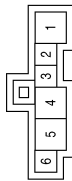

Terminal No.	Color of Wire	Signal Name
1	GR	-
3	W	-
4	L	-

Connector No.	M127
Connector Name	WIRE TO WIRE
Connector Color	WHITE

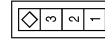

Terminal No.	Color of Wire	Signal Name
1	GR	-
2	GR	-
3	GR	-

Connector No.	M124
Connector Name	AV CONTROL UNIT (WITH BOSE AUDIO SYSTEM - WITH NAVI WITHOUT SURROUND SOUND SYSTEM)
Connector Color	WHITE



Terminal No.	Color of Wire	Signal Name
61	W	IT DISP
62	P	CAN-L
63	LG	M-CAN L
76	SHIELD	DISP SHIELD
77	B	DISP IT
78	L	CAN-H
79	SB	M-CAN H

Connector No.	M119
Connector Name	IONIZER
Connector Color	WHITE

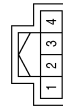

Terminal No.	Color of Wire	Signal Name
1	LG	-
3	B	-
4	P	-

ABIIA1548GB

A
B
C
D
E
F
G
H
HAC
J
K
L
M
N
O
P

AUTOMATIC AIR CONDITIONING SYSTEM

< WIRING DIAGRAM >

[AUTOMATIC AIR CONDITIONING]

Connector No.	M128
Connector Name	INTAKE DOOR MOTOR
Connector Color	WHITE

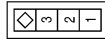

Terminal No.	Color of Wire	Signal Name
1	GR	-
2	GR	-
3	GR	-

Connector No.	M129
Connector Name	MODE DOOR MOTOR (FRONT)
Connector Color	WHITE

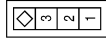

Terminal No.	Color of Wire	Signal Name
1	GR	-
2	GR	-
3	GR	-

Connector No.	M130
Connector Name	AIR MIX DOOR MOTOR DRIVER SIDE
Connector Color	WHITE

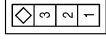

Terminal No.	Color of Wire	Signal Name
1	GR	-
2	GR	-
3	GR	-

Connector No.	M131
Connector Name	AIR MIX DOOR MOTOR PASSENGER SIDE
Connector Color	WHITE



Terminal No.	Color of Wire	Signal Name
1	GR	-
2	GR	-
3	GR	-

Connector No.	M132
Connector Name	AIR MIX DOOR MOTOR (REAR)
Connector Color	WHITE

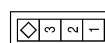

Terminal No.	Color of Wire	Signal Name
1	GR	-
2	GR	-
3	GR	-

Connector No.	M157
Connector Name	WIRE TO WIRE
Connector Color	WHITE

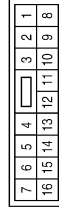

Terminal No.	Color of Wire	Signal Name
13	L	-

AUTOMATIC AIR CONDITIONING SYSTEM

< WIRING DIAGRAM >

[AUTOMATIC AIR CONDITIONING]

Connector No.	M176
Connector Name	JOINT CONNECTOR-M56
Connector Color	WHITE



Terminal No.	Color of Wire	Signal Name
1	SB	-
2	SB	-

Connector No.	M170
Connector Name	JOINT CONNECTOR-M09
Connector Color	WHITE

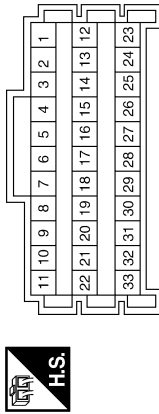

Terminal No.	Color of Wire	Signal Name
12	G	-
14	G	-
15	G	-
16	G	-
17	G	-

Connector No.	M163
Connector Name	AV CONTROL UNIT (WITH BOSE AUDIO SYSTEM - WITH NAVI AND SURROUND SOUND SYSTEM)
Connector Color	WHITE

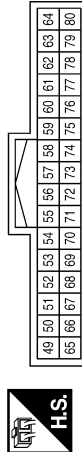

Terminal No.	Color of Wire	Signal Name
61	W	IT DISP
62	P	CAN-L
63	LG	M-CAN L
76	SHIELD	DISP SHIELD
77	B	DISP IT
78	L	CAN-H
79	SB	M-CAN H

Connector No.	M194
Connector Name	AV CONTROL UNIT (WITH BOSE AUDIO SYSTEM WITHOUT NAVI)
Connector Color	WHITE



Terminal No.	Color of Wire	Signal Name
61	B	DISP IT
72	SHIELD	SHIELD
73	W	IT DISP

Connector No.	M192
Connector Name	AV CONTROL UNIT (WITH BOSE AUDIO SYSTEM WITHOUT NAVI)
Connector Color	WHITE

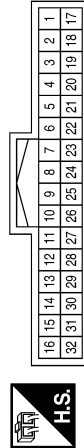

Terminal No.	Color of Wire	Signal Name
11	L	CAN-H
12	P	CAN-L
13	SB	M-CAN1 H
14	LG	M-CAN1 L

Connector No.	M177
Connector Name	JOINT CONNECTOR-M57
Connector Color	WHITE



Terminal No.	Color of Wire	Signal Name
1	LG	-
2	LG	-

ABIIA1130GB

A
B
C
D
E
F
G
H
HAC
J
K
L
M
N
O
P

AUTOMATIC AIR CONDITIONING SYSTEM

< WIRING DIAGRAM >

[AUTOMATIC AIR CONDITIONING]

Connector No.	M216
Connector Name	WIRE TO WIRE
Connector Color	WHITE

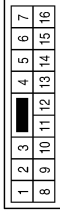

Terminal No.	Color of Wire	Signal Name
3	B	-

Connector No.	M211
Connector Name	DRIVE MODE SELECT SWITCH
Connector Color	BLACK

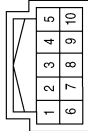

Terminal No.	Color of Wire	Signal Name
1	W	-
2	L	-
3	G	-
4	Y	-
6	B	-

Connector No.	M202
Connector Name	WIRE TO WIRE
Connector Color	WHITE

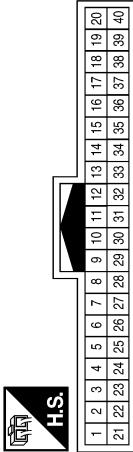

Terminal No.	Color of Wire	Signal Name
2	LG	-
3	W	-
4	G	-
24	B	-

Connector No.	M258
Connector Name	REAR AIR CONTROL
Connector Color	WHITE

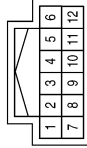

Terminal No.	Color of Wire	Signal Name
1	B	GND
2	-	-
3	-	-
4	-	-
5	R	ILL (+)
6	B	ILL (-)
7	-	-
8	-	-
9	G	RX (FR → RR)
10	W	TX (RR → FR)
11	-	-
12	LG	IGN

Connector No.	M257
Connector Name	WIRE TO WIRE
Connector Color	WHITE

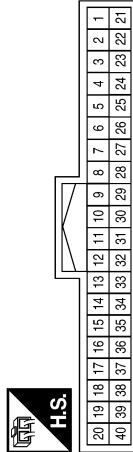

Terminal No.	Color of Wire	Signal Name
2	LG	-
3	W	-
4	G	-
24	B	-

Connector No.	M217
Connector Name	WIRE TO WIRE
Connector Color	WHITE

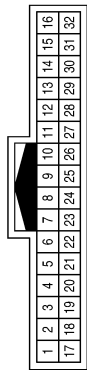

Terminal No.	Color of Wire	Signal Name
17	W	-
18	L	-
19	G	-
20	Y	-
25	G	-
26	W	-
27	LG	-

AB11A1131GB

AUTOMATIC AIR CONDITIONING SYSTEM

< WIRING DIAGRAM >

[AUTOMATIC AIR CONDITIONING]

Connector No.	E11
Connector Name	PTC RELAY-1
Connector Color	BLUE



Terminal No.	Color of Wire	Signal Name
1	R	-
2	W	-
3	Y	-
5	Y	-

Connector No.	E5
Connector Name	WIRE TO WIRE
Connector Color	WHITE

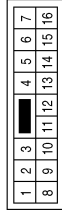

Terminal No.	Color of Wire	Signal Name
10	G	-
12	P	-

Connector No.	E2
Connector Name	WIRE TO WIRE
Connector Color	WHITE

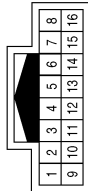

Terminal No.	Color of Wire	Signal Name
12	Y	-
13	LG	-
14	V	-

Connector No.	E19
Connector Name	WIRE TO WIRE
Connector Color	WHITE



Terminal No.	Color of Wire	Signal Name
10	GR	-

Connector No.	E16
Connector Name	ECM (FOR MEXICO)
Connector Color	GRAY

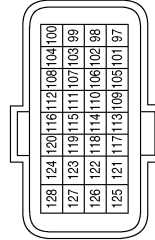

Terminal No.	Color of Wire	Signal Name
113	P	CAN-L
114	L	CAN-H

Connector No.	E12
Connector Name	PTC RELAY-2
Connector Color	BLUE



Terminal No.	Color of Wire	Signal Name
1	R	-
2	BG	-
3	W	-
5	P	-

ABIIA1540GB

A
B
C
D
E
F
G
H
HAC
J
K
L
M
N
O
P

AUTOMATIC AIR CONDITIONING SYSTEM

< WIRING DIAGRAM >

[AUTOMATIC AIR CONDITIONING]

Connector No.	E28
Connector Name	FUSE BLOCK (J/B)
Connector Color	WHITE

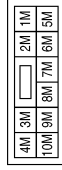

Terminal No.	Color of Wire	Signal Name
1M	R	-

Connector No.	E26
Connector Name	WIRE TO WIRE
Connector Color	WHITE

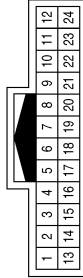

Terminal No.	Color of Wire	Signal Name
18	P	-
19	W	-

Connector No.	E22
Connector Name	ACCESSORY RELAY-2
Connector Color	BLUE



Terminal No.	Color of Wire	Signal Name
1	G	-
2	B	-
3	R	-
5	P	-

Connector No.	E44
Connector Name	JOINT CONNECTOR-E01
Connector Color	WHITE

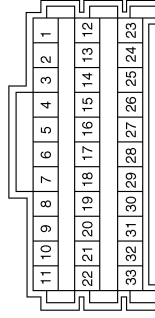

Terminal No.	Color of Wire	Signal Name
15	GR	-
17	B	-

Connector No.	E36
Connector Name	WIRE TO WIRE
Connector Color	WHITE

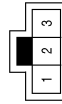

Terminal No.	Color of Wire	Signal Name
2	P	-
3	Y	-

Connector No.	E32
Connector Name	ECM (EXCEPT FOR MEXICO)
Connector Color	BLACK

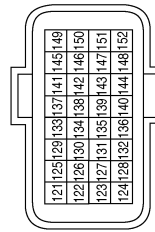

Terminal No.	Color of Wire	Signal Name
123	P	CAN-L
124	L	CAN-H

ABIIA15416B

AUTOMATIC AIR CONDITIONING SYSTEM

[AUTOMATIC AIR CONDITIONING]

< WIRING DIAGRAM >

Connector No.	E71
Connector Name	JOINT CONNECTOR-E15
Connector Color	BLACK



Terminal No.	Color of Wire	Signal Name
1	L	-
2	L	-

Connector No.	E70
Connector Name	JOINT CONNECTOR-E14
Connector Color	BLACK



Terminal No.	Color of Wire	Signal Name
1	P	-
2	P	-

Connector No.	E45
Connector Name	JOINT CONNECTOR-E12
Connector Color	BLUE

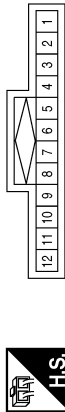

Terminal No.	Color of Wire	Signal Name
1	L	-
2	L	-
4	L	-
7	P	-
8	P	-
10	P	-

Connector No.	E121
Connector Name	IPDM E/R (INTELLIGENT POWER DISTRIBUTION MODULE ENGINE ROOM)
Connector Color	WHITE

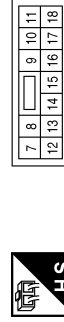

Terminal No.	Color of Wire	Signal Name
7	B	GND (POWER)

Terminal No.	Color of Wire	Signal Name
28	P	CAN-L
29	L	CAN-H
41	B	GND (SIGNAL)
43	L	IGN SIGNAL
45	LG	PD SENS SIG-E/R
47	Y	PD SENS PWR-E/R
48	V	PD SENS GND-E/R

Connector No.	E119
Connector Name	IPDM E/R (INTELLIGENT POWER DISTRIBUTION MODULE ENGINE ROOM)
Connector Color	WHITE

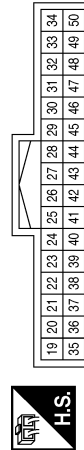

ABI1A1542GB

A
B
C
D
E
F
G
H
HAC
J
K
L
M
N
O
P

AUTOMATIC AIR CONDITIONING SYSTEM

< WIRING DIAGRAM >

[AUTOMATIC AIR CONDITIONING]

Connector No.	E206
Connector Name	AMBIENT SENSOR
Connector Color	BLACK



Terminal No.	Color of Wire	Signal Name
1	L	-
2	Y	-

Terminal No.	Color of Wire	Signal Name
3G	P	-
8G	G	-
11G	G	-
12G	P	-
13G	W	-
21G	P	-
35G	P	-
36G	L	-
37G	BG	-
38G	W	-
50G	G	-
63G	L	-
94G	Y	-

Connector No.	E152
Connector Name	WIRE TO WIRE
Connector Color	WHITE

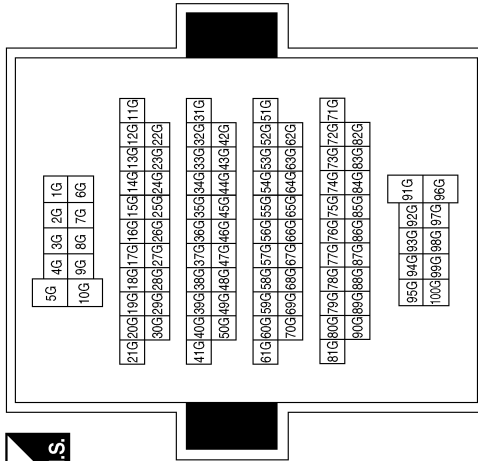

Connector No.	E218
Connector Name	IPDM E/R (INTELLIGENT POWER DISTRIBUTION MODULE ENGINE ROOM)
Connector Color	WHITE

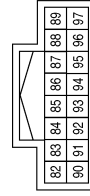

Terminal No.	Color of Wire	Signal Name
82	P	PD SENS SIG-FEM
83	G	PD SENS PWR-FEM
86	L	PD SENS GND-FEM

Connector No.	E209
Connector Name	WIRE TO WIRE
Connector Color	WHITE



Terminal No.	Color of Wire	Signal Name
18	L	-
19	Y	-

Connector No.	E207
Connector Name	WIRE TO WIRE
Connector Color	WHITE

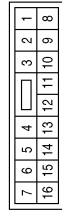

Terminal No.	Color of Wire	Signal Name
10	G	-
12	R	-

AB11A15436B

AUTOMATIC AIR CONDITIONING SYSTEM

[AUTOMATIC AIR CONDITIONING]

< WIRING DIAGRAM >

Connector No.	F3
Connector Name	A/C COMPRESSOR
Connector Color	BLACK



Terminal No.	Color of Wire	Signal Name
1	SB	-
2	B	-

Connector No.	E244
Connector Name	REFRIGERANT PRESSURE SENSOR
Connector Color	BLACK



Terminal No.	Color of Wire	Signal Name
1	G	-
2	P	-(FOR MEXICO)
2	W	-(EXCEPT FOR MEXICO)
3	L	-(FOR MEXICO)
3	R	-(EXCEPT FOR MEXICO)

Connector No.	E227
Connector Name	EXHAUST GAS/OUTSIDE ODOR DETECTING SENSOR
Connector Color	BLACK



Terminal No.	Color of Wire	Signal Name
1	R	-
2	B	-
3	G	-

Connector No.	F33
Connector Name	WIRE TO WIRE
Connector Color	WHITE



Terminal No.	Color of Wire	Signal Name
10	B	-

Connector No.	F32
Connector Name	WIRE TO WIRE
Connector Color	WHITE

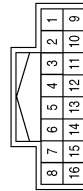

Terminal No.	Color of Wire	Signal Name
12	P	-(FOR MEXICO)
12	Y	-(EXCEPT FOR MEXICO)
13	SB	-
14	V	-

Connector No.	F19
Connector Name	IPDM E/R (INTELLIGENT POWER DISTRIBUTION MODULE ENGINE ROOM)
Connector Color	WHITE

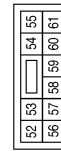

Terminal No.	Color of Wire	Signal Name
56	SB	A/C COMP

ABI1A1544GB

A
B
C
D
E
F
G
H
HAC
J
K
L
M
N
O
P

AUTOMATIC AIR CONDITIONING SYSTEM

< WIRING DIAGRAM >

[AUTOMATIC AIR CONDITIONING]

Connector No.	B11
Connector Name	JOINT CONNECTOR-B09
Connector Color	WHITE



Terminal No.	Color of Wire	Signal Name
1	P	-
2	P	-

Connector No.	F78
Connector Name	ECM (EXCEPT FOR MEXICO)
Connector Color	BLACK

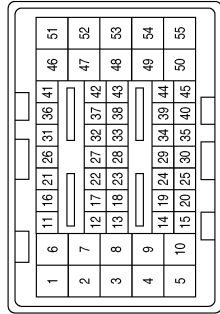

Terminal No.	Color of Wire	Signal Name
18	Y	SENSOR POWER SUPPLY
20	SB	REFRIGERANT PRESSURE SENSOR
25	V	SENSOR GROUND (IPDM E/R)

Connector No.	F52
Connector Name	ECM (FOR MEXICO)
Connector Color	BROWN

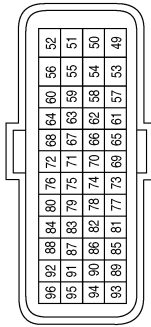

Terminal No.	Color of Wire	Signal Name
63	SB	REFRIGERANT PRESSURE SENSOR
64	V	SENSOR GROUND (REFRIGERANT PRESSURE SENSOR)
96	P	SENSOR POWER SUPPLY (REFRIGERANT PRESSURE SENSOR)

Connector No.	B17
Connector Name	JOINT CONNECTOR-B12
Connector Color	WHITE

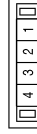

Terminal No.	Color of Wire	Signal Name
1	L	-
2	L	-

Connector No.	B16
Connector Name	JOINT CONNECTOR-B11
Connector Color	WHITE

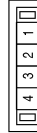

Terminal No.	Color of Wire	Signal Name
1	P	-
2	P	-

Connector No.	B12
Connector Name	JOINT CONNECTOR-B10
Connector Color	WHITE



Terminal No.	Color of Wire	Signal Name
1	L	-
2	L	-

AB11A15456B

AUTOMATIC AIR CONDITIONING SYSTEM

< WIRING DIAGRAM >

[AUTOMATIC AIR CONDITIONING]

Terminal No.	Color of Wire	Signal Name
89A	L	-
90A	P	-

Connector No.	B69
Connector Name	WIRE TO WIRE
Connector Color	GRAY

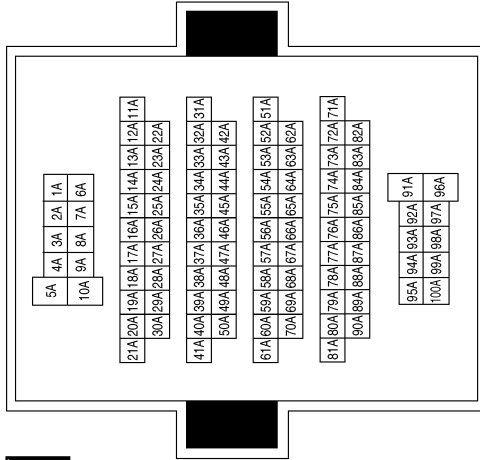

Connector No.	B32
Connector Name	WIRE TO WIRE
Connector Color	WHITE

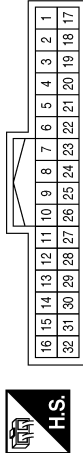

Terminal No.	Color of Wire	Signal Name
18	L	-
19	P	-

Connector No.	B103
Connector Name	JOINT CONNECTOR-B15
Connector Color	WHITE

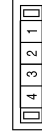

Connector No.	B102
Connector Name	JOINT CONNECTOR-B14
Connector Color	WHITE

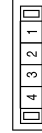

Terminal No.	Color of Wire	Signal Name
1	P	-
2	P	-

Connector No.	B101
Connector Name	WIRE TO WIRE
Connector Color	WHITE

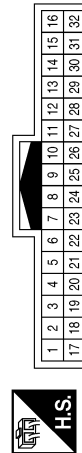

Terminal No.	Color of Wire	Signal Name
17	L	-
18	P	-
23	W	-

ABI1A1546GB

A
B
C
D
E
F
G
H
HAC
J
K
L
M
N
O
P

AUTOMATIC AIR CONDITIONING SYSTEM

[AUTOMATIC AIR CONDITIONING]

< WIRING DIAGRAM >

Connector No.	B133
Connector Name	REAR BLOWER MOTOR RESISTOR 2
Connector Color	WHITE



Terminal No.	Color of Wire	Signal Name
1	SB	-
2	W	-
3	GR	-

Connector No.	B124
Connector Name	WIRE TO WIRE
Connector Color	WHITE

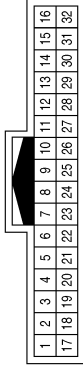

Terminal No.	Color of Wire	Signal Name
18	L	-
19	P	-

Connector No.	B106
Connector Name	WIRE TO WIRE
Connector Color	GRAY



Terminal No.	Color of Wire	Signal Name
1	W	-

Connector No.	B161
Connector Name	WIRE TO WIRE
Connector Color	WHITE

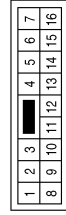

Terminal No.	Color of Wire	Signal Name
13	SB	-

Connector No.	B134
Connector Name	REAR BLOWER MOTOR 2
Connector Color	WHITE



Terminal No.	Color of Wire	Signal Name
1	W	-
2	SB	-

ABI1A1547GB

AUTOMATIC AIR CONDITIONING SYSTEM

< WIRING DIAGRAM >

[AUTOMATIC AIR CONDITIONING]

A
B
C
D
E
F
G
H
HAC
J
K
L
M
N
O
P

Connector No.	J-4
Connector Name	FUSE BLOCK (J/B) (FRONT BLOWER MOTOR RELAY)
Connector Color	-

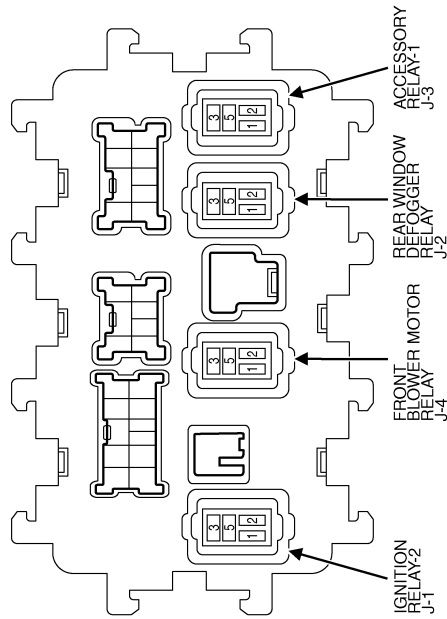

ABIIA1549GB

DIAGNOSIS AND REPAIR WORK FLOW

< BASIC INSPECTION >

[AUTOMATIC AIR CONDITIONING]

BASIC INSPECTION

DIAGNOSIS AND REPAIR WORK FLOW

Work Flow

INFOID:000000011136119

OVERALL SEQUENCE

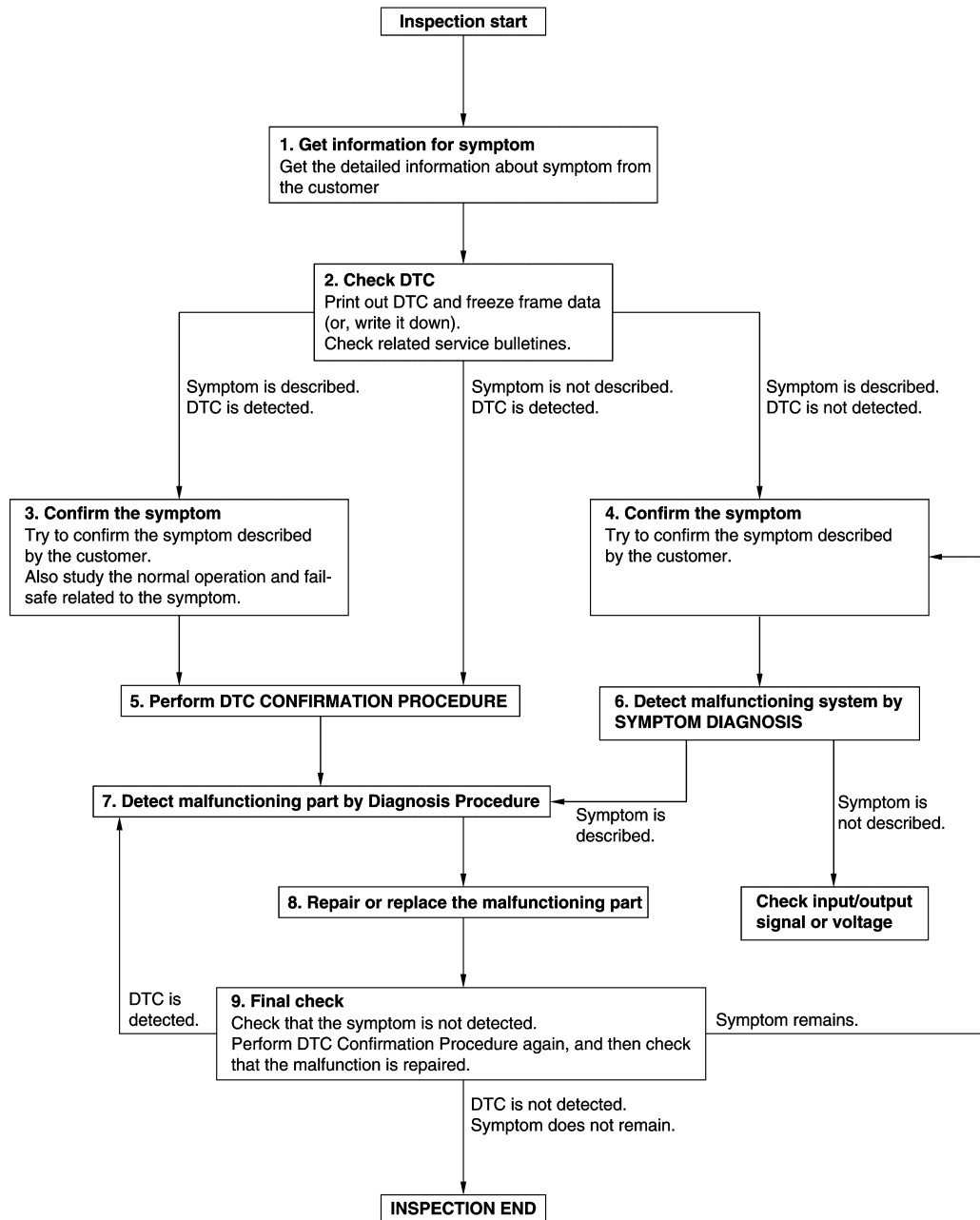

JMKIA8652GB

DETAILED FLOW

Revision: August 2014

HAC-74

2015 QX60 NAM

DIAGNOSIS AND REPAIR WORK FLOW

< BASIC INSPECTION >

[AUTOMATIC AIR CONDITIONING]

1. GET INFORMATION FOR SYMPTOM

1. Get detailed information from the customer about the symptom (the condition and the environment when the incident/malfunction occurs).
2. Check operation condition of the function that is malfunctioning.

>> GO TO 2.

2. CHECK DTC

1. Check DTC.
2. Perform the following procedure if DTC is detected.
 - Record DTC and freeze frame data (Print them out using CONSULT.)
 - Erase DTC.
 - Study the relationship between the cause detected by DTC and the symptom described by the customer.
3. Check related service bulletins for information.

Are any symptoms described and any DTC detected?

Symptom is described, DTC is detected>>GO TO 3.

Symptom is described, DTC is not detected>>GO TO 4.

Symptom is not described, DTC is detected>>GO TO 5.

3. CONFIRM THE SYMPTOM

Try to confirm the symptom described by the customer.

Also study the normal operation and fail-safe related to the symptom.

Verify relation between the symptom and the condition when the symptom is detected.

>> GO TO 5.

4. CONFIRM THE SYMPTOM

Try to confirm the symptom described by the customer.

Verify relation between the symptom and the condition when the symptom is detected.

>> GO TO 6.

5. PERFORM DTC CONFIRMATION PROCEDURE

Perform DTC CONFIRMATION PROCEDURE for the detected DTC, and then check that DTC is detected again. At this time, always connect CONSULT to the vehicle, and check self diagnostic results in real time. If two or more DTCs are detected, refer to DTC INSPECTION PRIORITY CHART, and determine trouble diagnosis order.

NOTE:

- Freeze frame data is useful if the DTC is not detected.
- Perform Component Function Check if DTC CONFIRMATION PROCEDURE is not included on Service Manual. This simplified check procedure is an effective alternative though DTC cannot be detected during this check.

If the result of Component Function Check is NG, it is the same as the detection of DTC by DTC CONFIRMATION PROCEDURE.

Is DTC detected?

YES >> GO TO 7.

NO >> Check according to [GI-50. "Intermittent Incident"](#).

6. DETECT MALFUNCTIONING SYSTEM BY SYMPTOM DIAGNOSIS

Detect malfunctioning system according to SYMPTOM DIAGNOSIS based on the confirmed symptom in step 4, and determine the trouble diagnosis order based on possible causes and symptom.

Is the symptom described?

YES >> GO TO 7.

NO >> Monitor input data from related sensors or check voltage of related module terminals using CONSULT.

7. DETECT MALFUNCTIONING PART BY DIAGNOSIS PROCEDURE

DIAGNOSIS AND REPAIR WORK FLOW

[AUTOMATIC AIR CONDITIONING]

< BASIC INSPECTION >

Inspect according to Diagnosis Procedure of the system.

Is malfunctioning part detected?

YES >> GO TO 8.

NO >> Check according to [GI-50. "Intermittent Incident"](#).

8. REPAIR OR REPLACE THE MALFUNCTIONING PART

1. Repair or replace the malfunctioning part.
2. Reconnect parts or connectors disconnected during Diagnosis Procedure again after repair and replacement.
3. Check DTC. If DTC is detected, erase it.

>> GO TO 9.

9. FINAL CHECK

When DTC is detected in step 2, perform DTC CONFIRMATION PROCEDURE again, and then check that the malfunction is repaired securely.

When symptom is described by the customer, refer to confirmed symptom in step 3 or 4, and check that the symptom is not detected.

Is DTC detected and does symptom remain?

YES-1 >> DTC is detected: GO TO 7.

YES-2 >> Symptom remains: GO TO 4.

NO >> Before returning the vehicle to the customer, always erase DTC.

OPERATION INSPECTION

< BASIC INSPECTION >

[AUTOMATIC AIR CONDITIONING]

OPERATION INSPECTION

FRONT AUTOMATIC AIR CONDITIONING SYSTEM

FRONT AUTOMATIC AIR CONDITIONING SYSTEM : Work Procedure

INFOID:000000011136120

DESCRIPTION

The purpose of the operational check is to check that the individual system operates normally.

Check condition : Engine running at normal operating temperature.

OPERATION INSPECTION

1. CHECK MEMORY FUNCTION

1. Set temperature control (driver side) to 32.0°C (90°F).
2. Press OFF switch.
3. Turn ignition switch OFF.
4. Turn ignition switch ON.
5. Press AUTO switch.
6. Check that set temperature is maintained.

Is the inspection result normal?

YES >> GO TO 2.

NO >> GO TO 9.

2. CHECK FRONT BLOWER MOTOR

1. Start engine.
2. Operate fan switch.
3. Check that fan speed changes. Check operation for all fan speeds.

Is the inspection result normal?

YES >> GO TO 3.

NO >> GO TO 9.

3. CHECK DISCHARGE AIR (MODE SWITCH AND DEF SWITCH)

1. Operate fan switch to set the fan speed to maximum speed.
2. Operate MODE switch and DEF switch.
3. Check that air outlets change according to each indicated air outlet by placing a hand in front of the outlets. Refer to [HAC-19, "FRONT AUTOMATIC AIR CONDITIONING SYSTEM : System Description"](#).

Is the inspection result normal?

YES >> GO TO 4.

NO >> GO TO 9.

4. CHECK INTAKE AIR

1. Press REC switch to set the air inlet to recirculation. The REC switch indicator turns ON.
2. Listen to intake sound and confirm air inlets change.
3. Press REC switch again to set the air inlet to fresh air intake. The REC switch indicator turns OFF.
4. Listen to intake sound and confirm air inlets change.

Is the inspection result normal?

YES >> GO TO 5.

NO >> GO TO 9.

5. CHECK DISCHARGE AIR TEMPERATURE (LH/RH INDEPENDENT TEMPERATURE ADJUSTMENT FUNCTION)

1. Operate temperature control dial (driver side).
2. Check that discharge air temperature (driver side) changes.
3. Operate temperature control (passenger side). The DUAL switch indicator is turns ON.
4. Check that the discharge air temperature (passenger side) changes.
5. Press DUAL switch. The DUAL switch indicator turns OFF.
6. Check that air temperature setting (LH/RH) is unified to the driver side temperature setting.

Is the inspection result normal?

A
B
C
D
E
F
G
H
J
K
L
M
N
O
P

HAC

OPERATION INSPECTION

[AUTOMATIC AIR CONDITIONING]

< BASIC INSPECTION >

- YES >> GO TO 6.
NO >> GO TO 9.

6. CHECK WITH TEMPERATURE SETTING LOWERED

1. Operate compressor.
2. Operate temperature control (driver side) and lower the set temperature to 18°C (60°F).
3. Check that cool air blows from the air outlets.

Is the inspection result normal?

- YES >> GO TO 7.
NO >> GO TO 9.

7. CHECK TEMPERATURE INCREASE

1. Operate temperature control (driver side) and raise the set temperature to 32°C (90°F).
2. Check that warm air blows from the air outlets.

Is the inspection result normal?

- YES >> GO TO 8.
NO >> GO TO 9.

8. CHECK AUTO MODE

1. Press AUTO switch to confirm that "AUTO" is indicated on the display.
2. Operate temperature control (driver side) to check that fan speed or air outlet changes (the air outlet or fan speed varies depending on the ambient temperature, in-vehicle temperature, set temperature, etc.).

Is the inspection result normal?

- YES >> Inspection End.
NO >> GO TO 9.

9. CHECK SELF-DIAGNOSIS WITH CONSULT

1. Perform self-diagnosis with CONSULT.
2. Check that any DTC is detected.

Is any DTC detected?

- YES >> Refer to [HAC-48. "DTC Index"](#) and perform the appropriate diagnosis.
NO >> GO TO 10.

10. CHECK FAIL-SAFE ACTIVATION

Check that symptom is applied to the fail-safe activation. Refer to [HAC-48. "Fail-safe"](#).

>> Refer to [HAC-149. "Diagnosis Chart By Symptom"](#) and perform the appropriate diagnosis.

REAR AUTOMATIC AIR CONDITIONING SYSTEM

REAR AUTOMATIC AIR CONDITIONING SYSTEM : Work Procedure

INFOID:0000000011136121

DESCRIPTION

The purpose of the operational check is to check that the individual system operates normally.

NOTE:

Check that front automatic air conditioning system operates normally. Refer to [HAC-149. "Diagnosis Chart By Symptom"](#).

Check condition : Engine running at normal operating temperature.
: Front air conditioning system operate.

OPERATION INSPECTION

Front A/C Control Operation

1. CHECK REAR CONTROL MODE FUNCTION

1. Press REAR switch. The REAR switch indicator turns ON.
2. Check that display unit changes to state indication display (rear control mode) and that rear automatic air conditioning system starts.

OPERATION INSPECTION

[AUTOMATIC AIR CONDITIONING]

< BASIC INSPECTION >

3. Press REAR switch again. The REAR switch indicator turns OFF.
4. Check that rear control mode released. (rear automatic air conditioning system operates continuously)

Is the inspection result normal?

- YES >> GO TO 2.
NO >> GO TO 8.

2.CHECK REAR BLOWER MOTOR

1. Press REAR switch.
2. Operate fan switch.
3. Check that fan speed changes. Check operation for all fan speeds.

Is the inspection result normal?

- YES >> GO TO 3.
NO >> GO TO 8.

3.CHECK DISCHARGE AIR

1. Operate fan switch to set the fan speed to maximum speed.
2. Operate MODE switch.
3. Check that air outlets change according to each indicated air outlet by placing a hand in front of the outlets. Refer to [HAC-26. "REAR AUTOMATIC AIR CONDITIONING SYSTEM : System Description"](#).

Is the inspection result normal?

- YES >> GO TO 4.
NO >> GO TO 8.

4.CHECK DISCHARGE AIR TEMPERATURE

1. Operate temperature control dial (driver side).
2. Check that discharge air temperature changes.

Is the inspection result normal?

- YES >> GO TO 5.
NO >> GO TO 8.

5.CHECK WITH TEMPERATURE SETTING LOWERED

1. Operate temperature control dial (driver side) and lower the set temperature to 18°C (60°F).
2. Check that cool air blows from the air outlets.

Is the inspection result normal?

- YES >> GO TO 6.
NO >> GO TO 8.

6.CHECK TEMPERATURE INCREASE

1. Operate temperature control dial (driver side) and raise the set temperature to 32°C (90°F).
2. Check that warm air blows from the air outlets.

Is the inspection result normal?

- YES >> GO TO 7.
NO >> GO TO 8.

7.CHECK AUTO MODE

1. Press AUTO switch.
2. Operate temperature control dial (driver side) to check that fan speed or air outlet changes (the air outlet or fan speed varies depending on the ambient temperature, in-vehicle temperature, set temperature, and etc.).

Is the inspection result normal?

- YES >> Inspection End.
NO >> GO TO 8.

8.CHECK SELF-DIAGNOSIS WITH CONSULT

1. Perform self-diagnosis with CONSULT.
2. Check that any DTC is detected.

Is any DTC detected?

A
B
C
D
E
F
G
H
J
K
L
M
N
O
P

HAC

OPERATION INSPECTION

[AUTOMATIC AIR CONDITIONING]

< BASIC INSPECTION >

- YES >> Refer to [HAC-48. "DTC Index"](#) and perform the appropriate diagnosis.
NO >> Refer to [HAC-151. "Diagnosis Chart By Symptom"](#) and perform the appropriate diagnosis.

Rear Air Control Operation

1. CHECK REAR BLOWER MOTOR

1. Press AUTO switch.
2. Operate fan switch.
3. Check that fan speed changes. Check operation for all fan speeds.

Is the inspection result normal?

- YES >> GO TO 2.
NO >> GO TO 7.

2. CHECK DISCHARGE AIR

1. Operate fan switch to set the fan speed to maximum speed.
2. Operate MODE switch.
3. Check that air outlets change according to each indicated air outlet by placing a hand in front of the outlets. Refer to [HAC-26. "REAR AUTOMATIC AIR CONDITIONING SYSTEM : System Description"](#).

Is the inspection result normal?

- YES >> GO TO 3.
NO >> GO TO 7.

3. CHECK DISCHARGE AIR TEMPERATURE

1. Operate temperature control switch.
2. Check that discharge air temperature changes.

Is the inspection result normal?

- YES >> GO TO 4.
NO >> GO TO 7.

4. CHECK WITH TEMPERATURE SETTING LOWERED

1. Operate temperature control switch and lower the set temperature to 18°C.
2. Check that cool air blows from the air outlets.

Is the inspection result normal?

- YES >> GO TO 5.
NO >> GO TO 7.

5. CHECK TEMPERATURE INCREASE

1. Operate temperature control switch and raise the set temperature to 32°C.
2. Check that warm air blows from the air outlets.

Is the inspection result normal?

- YES >> GO TO 6.
NO >> GO TO 7.

6. CHECK AUTO MODE

1. Press AUTO switch.
2. Operate temperature control switch to check that fan speed or air outlet changes (the air outlet or fan speed varies depending on the ambient temperature, in-vehicle temperature (rear side), set temperature, and etc.).

Is the inspection result normal?

- YES >> Inspection End.
NO >> GO TO 7.

7. CHECK SELF-DIAGNOSIS WITH CONSULT

1. Perform self-diagnosis with CONSULT.
2. Check that any DTC is detected.

Is any DTC detected?

- YES >> Refer to [HAC-48. "DTC Index"](#) and perform the appropriate diagnosis.
NO >> Refer to [HAC-151. "Diagnosis Chart By Symptom"](#) and perform the appropriate diagnosis.

OPERATION INSPECTION

< BASIC INSPECTION >

[AUTOMATIC AIR CONDITIONING]

ACCS (ADVANCED CLIMATE CONTROL SYSTEM)

ACCS (ADVANCED CLIMATE CONTROL SYSTEM) : Work Procedure

INFOID:000000011136122

DESCRIPTION

The purpose of the operational check is to check that the individual system operates normally.

NOTE:

Check that front automatic air conditioning system operates normally. Refer to [HAC-77, "FRONT AUTOMATIC AIR CONDITIONING SYSTEM : Work Procedure"](#).

Check condition : Engine running

OPERATION INSPECTION

1. CHECK PLASMACLUSTER™ CONTROL

Check the ionizer operation sound (whirring sound) in the duct by putting an ear to the center ventilator grille (driver side) outlet while pressing fan switch and OFF switch alternately.

Is the inspection result normal?

YES >> GO TO 2.

NO >> GO TO 4.

2. CHECK PLASMACLUSTER™ CONTROL OPERATION STATUS

Operate fan switch. Visually check that status indicator in display unit changes in accordance with the following table.

Fan speed	Display unit (ion indicator)
2nd	CLEAN
5th	QUICK CLEAN

Is the inspection result normal?

YES >> GO TO 3.

NO >> GO TO 4.

3. CHECK AUTOMATIC INTAKE CONTROL (EXHAUST GAS / OUTSIDE ODOR DETECTING MECHANISM)

- Operate fan switch to set the fan speed to maximum speed.
- Press auto intake switch to set the air inlet to recirculation. The auto intake switch indicator and intake switch indicator turn ON.
- Listen to intake sound and confirm air inlets change.
- Wait approximately for 5 minutes until air inlet switches to fresh air intake.
- Apply cigarette smoke or similar substance to exhaust gas / outside odor detecting sensor portion.
- Listen to intake sound and confirm air inlets change to recirculation.

Is the inspection result normal?

YES >> Inspection End.

NO >> GO TO 4.

4. CHECK SELF-DIAGNOSIS WITH CONSULT

- Perform self-diagnosis with CONSULT.
- Check that any DTC is detected.

Is any DTC detected?

YES >> Refer to [HAC-48, "DTC Index"](#) and perform the appropriate diagnosis.

NO >> Refer to [HAC-151, "Diagnosis Chart By Symptom"](#) and perform the appropriate diagnosis.

A
B
C
D
E
F
G
H
J
K
L
M
N
O
P

HAC

SYSTEM SETTING

< BASIC INSPECTION >

[AUTOMATIC AIR CONDITIONING]

SYSTEM SETTING

FRONT AUTOMATIC AIR CONDITIONING SYSTEM

FRONT AUTOMATIC AIR CONDITIONING SYSTEM : Temperature Setting Trimmer (Front)

INFOID:000000011136123

DESCRIPTION

If the temperature felt by the customer is different from the front air flow temperature controlled by the temperature setting, the A/C auto amp. control temperature can be adjusted to compensate for the temperature setting.

HOW TO SET

Ⓟ With CONSULT

Perform "TEMP SET CORRECT" of HVAC work support item.

Work support items	Display (°C)	Display (°F)
TEMP SET CORRECT	3.0	6
	2.5	5
	2.0	4
	1.5	3
	1.0	2
	0.5	1
	0 (initial status)	0 (initial status)
	-0.5	-1
	-1.0	-2
	-1.5	-3
	-2.0	-4
	-2.5	-5
	-3.0	-6

NOTE:

- When -3.0°C (-6°F) is corrected on the temperature setting set as 25.0°C (77°F) the temperature controlled by A/C auto amp. is 25.0°C (77°F) -3.0°C (-6°F) = 22.0°C (72°F) and the temperature becomes lower than the temperature setting.
- When the battery cable is disconnected from the negative terminal or when the battery voltage becomes 10 V or less, the setting of the difference between the set temperature and control temperature may be cancelled.

FRONT AUTOMATIC AIR CONDITIONING SYSTEM : Foot Position Setting Trimmer

INFOID:000000011136124

DESCRIPTION

In FOOT mode, the air blowing to DEF can change ON/OFF.

HOW TO SET

Ⓟ With CONSULT

Perform the "BLOW SET" of HVAC work support item.

Work support items	Display	Defroster door position	
		Auto control	Manual control
BLOW SET	Mode1	OPEN	CLOSE
	Mode2 (initial status)	OPEN	OPEN
	Mode3	CLOSE	OPEN
	Mode4	CLOSE	CLOSE

SYSTEM SETTING

< BASIC INSPECTION >

[AUTOMATIC AIR CONDITIONING]

NOTE:

When the battery cable is disconnected from the negative terminal or when the battery voltage becomes 10 V or less, the setting of the discharge air mix ratio in FOOT mode may be cancelled.

FRONT AUTOMATIC AIR CONDITIONING SYSTEM : Inlet Port Memory Function (FRE)

INFOID:000000011136125

DESCRIPTION

- If the ignition switch is turned to the OFF position while the intake switch is set to OFF (fresh air intake), “Perform the memory” or “Do not perform the memory” of intake switch OFF (fresh air intake) condition can be selected.
- If “Perform the memory” was set, the intake switch will be OFF (fresh air intake) when turning the ignition switch to the ON position again.
- If “Do not perform the memory” was set, the air inlets will be controlled automatically when turning the ignition switch to the ON position again.

HOW TO SET

Ⓜ With CONSULT

Perform the “FRE MEMORY SET” of HVAC work support item.

Work support items	Display	Setting
FRE MEMORY SET	WITHOUT	Perform the memory of manual FRE
	WITH (initial status)	Do not perform the memory of manual FRE (auto control)

NOTE:

When the battery cable is disconnected from the negative terminal or when the battery voltage becomes 10 V or less, the setting of the FRE memory function may be cancelled.

FRONT AUTOMATIC AIR CONDITIONING SYSTEM : Inlet Port Memory Function (REC)

INFOID:000000011136126

DESCRIPTION

- If the ignition switch is turned to the OFF position while the intake switch is set to ON (recirculation), “Perform the memory” or “Do not perform the memory” of intake switch ON (recirculation) condition can be selected.
- If “Perform the memory” was set, the intake switch will be ON (recirculation) when turning the ignition switch to the ON position again.
- If “Do not perform the memory” was set, the air inlets will be controlled automatically when turning the ignition switch to the ON position again.

HOW TO SET

Ⓜ With CONSULT

Perform the “REC MEMORY SET” of HVAC work support item.

Work support items	Display	Setting
REC MEMORY SET	WITHOUT (initial status)	Perform the memory of manual REC
	WITH	Do not perform the memory of manual REC (auto control)

NOTE:

When the battery cable is disconnected from the negative terminal or when the battery voltage becomes 10 V or less, the setting of the REC memory function may be cancelled.

REAR AUTOMATIC AIR CONDITIONING SYSTEM

REAR AUTOMATIC AIR CONDITIONING SYSTEM : Temperature Setting Trimmer (Rear)

INFOID:000000011136127

DESCRIPTION

A
B
C
D
E
F
G
H
J
K
L
M
N
O
P

HAC

SYSTEM SETTING

< BASIC INSPECTION >

[AUTOMATIC AIR CONDITIONING]

If the temperature felt by the customer is different from the rear air flow temperature controlled by the temperature setting, the A/C auto amp. control temperature can be adjusted to compensate for the temperature setting.

HOW TO SET

Ⓟ With CONSULT

Perform "REAR TEMP SET CORRECT" of HVAC work support item.

Work support items	Display (°C)	Display (°F)
REAR TEMP SET CORRECT	3.0	6
	2.5	5
	2.0	4
	1.5	3
	1.0	2
	0.5	1
	0 (initial status)	0 (initial status)
	-0.5	-1
	-1.0	-2
	-1.5	-3
	-2.0	-4
	-2.5	-5
	-3.0	-6

NOTE:

- When -3.0°C (-6°F) is corrected on the temperature setting set as 25.0°C (77°F) the temperature controlled by A/C auto amp. is 25.0°C (77°F) -3.0°C (-6°F) = 22.0°C (72°F) and the temperature becomes lower than the temperature setting.
- When the battery cable is disconnected from the negative terminal or when the battery voltage becomes 10 V or less, the setting of the difference between the set temperature and control temperature may be cancelled.

ACCS (ADVANCED CLIMATE CONTROL SYSTEM)

ACCS (ADVANCED CLIMATE CONTROL SYSTEM) : Exhaust Gas / Outside Odor Detecting Sensor Sensitivity Adjustment Function

INFOID:000000011136128

DESCRIPTION

According to customer's sense of smell, exhaust gas / outside odor detecting sensor sensitivity can be changed.

HOW TO SET

Ⓟ With CONSULT

Perform the "GAS SENSOR ADJUSTMENT" of HVAC work support item.

Work support items	Display	Setting
GAS SENSOR ADJUSTMENT	2	More sensitive setting than display 1 (REC earlier than display 1).
	1	More sensitive setting than normal setting (REC earlier than normal operation).
	0 (initial status)	Normal
	-1	Less sensitive setting than normal setting (REC later than normal operation).
	-2	Less sensitive setting than display -1 (REC later than display -1).

NOTE:

When the battery cable is disconnected from the negative terminal or when the battery voltage becomes 10 V or less, the setting of WORK SUPPORT may be cancelled.

ACCS (ADVANCED CLIMATE CONTROL SYSTEM) : Auto Intake Switch Interlocking

SYSTEM SETTING

< BASIC INSPECTION >

[AUTOMATIC AIR CONDITIONING]

Movement Change Function

INFOID:000000011136129

DESCRIPTION

Condition for interlocking movement of auto intake switch and A/C switch can be changed. In addition operation of the auto intake switch, which activates the automatic intake control (exhaust gas / outside odor detecting mechanism), can be set to become available when the A/C switch is ON.

HOW TO SET

☑ With CONSULT

Perform the "CLEAN SW SET" of HVAC work support item.

Work support items	Display	Setting
CLEAN SW SET	Mode1	Initial setting
	Mode2	Setting 1
	Mode3	Setting 2
	Mode4	Setting 3

Initial setting	When the auto intake switch is ON, the A/C switch is also turned ON in synchronization with the auto intake switch. Control of the auto intake switch is functional even when the A/C switch is turned OFF.
Setting 1	When the auto intake switch is ON, the A/C switch is not turned ON in synchronization with the auto intake switch. Control of the auto intake switch is functional even when the A/C switch is turned OFF.
Setting 2	When the auto intake switch is ON, the A/C switch is also turned ON in synchronization with the auto intake switch. When the A/C switch is turned OFF, the auto intake switch is turned OFF in synchronization with the A/C switch.
Setting 3	Auto intake switch can be turned ON only when A/C switch is ON. When the A/C switch is turned OFF, the auto intake switch is turned OFF in synchronization with the A/C switch.

NOTE:

When the battery cable is disconnected from the negative terminal or when the battery voltage becomes 10 V or less, the setting of WORK SUPPORT may be cancelled.

A
B
C
D
E
F
G
H
HAC
J
K
L
M
N
O
P

DTC/CIRCUIT DIAGNOSIS

U1000 CAN COMM CIRCUIT

Description

INFOID:0000000011136130

CAN (Controller Area Network) is a serial communication system for real time application. It is an on-vehicle multiplex communication system with high data communication speed and excellent error detection ability. Many electronic control units are equipped onto vehicles, and each control unit shares information and links with other control units during operation (not independent). In CAN communication, control units are connected with two communication lines (CAN-H line, CAN-L line) allowing a high rate of information transmission with less wiring. Each control unit transmits/receives data but selectively reads required data only. Refer to [LAN-45, "CAN COMMUNICATION SYSTEM : CAN Communication Signal Chart"](#).

DTC Logic

INFOID:0000000011136131

DTC DETECTION LOGIC

DTC	Items (CONSULT screen terms)	DTC detection condition	Possible cause
U1000	CAN COMM CIRCUIT	When A/C auto amp. is not transmitting or receiving CAN communication signal for 2 or more seconds.	CAN communication system

DTC CONFIRMATION PROCEDURE

1. PERFORM SELF-DIAGNOSIS

④ With CONSULT

1. Turn ignition switch ON and wait for 2 seconds or more.
2. Using CONSULT, perform "SELF-DIAGNOSIS RESULTS" of HVAC.
3. Check if any DTC No. is displayed in the self-diagnosis results.

Is DTC detected?

- YES >> Refer to [HAC-86, "Diagnosis Procedure"](#).
 NO >> Refer to [GI-50, "Intermittent Incident"](#).

Diagnosis Procedure

INFOID:0000000011136132

1. CHECK CAN COMMUNICATION SYSTEM

Check CAN communication system. Refer to [LAN-28, "Trouble Diagnosis Flow Chart"](#).

>> Inspection End.

U1010 CONTROL UNIT (CAN)

[AUTOMATIC AIR CONDITIONING]

< DTC/CIRCUIT DIAGNOSIS >

U1010 CONTROL UNIT (CAN)

Description

INFOID:0000000011136133

Initial diagnosis of A/C auto amp.

DTC Logic

INFOID:0000000011136134

DTC DETECTION LOGIC

DTC	Items (CONSULT screen terms)	DTC detection condition	Possible cause
U1010	CONTROL UNIT (CAN)	When detecting error during the initial diagnosis of CAN controller of A/C auto amp.	A/C auto amp.

DTC CONFIRMATION PROCEDURE

1.PERFORM SELF-DIAGNOSIS

ⓂWith CONSULT

1. Turn ignition switch ON.
2. Using CONSULT, perform "SELF-DIAGNOSIS RESULTS" of HVAC.
3. Check if any DTC No. is displayed in the self-diagnosis results.

Is DTC detected?

- YES >> Refer to [HAC-87. "Diagnosis Procedure"](#).
NO >> Inspection End.

Diagnosis Procedure

INFOID:0000000011136135

1.REPLACE A/C AUTO AMP.

Replace A/C auto amp. Refer to [HAC-161. "Removal and Installation"](#).

>> Inspection End.

B2578, B2579 IN-VEHICLE SENSOR

< DTC/CIRCUIT DIAGNOSIS >

[AUTOMATIC AIR CONDITIONING]

B2578, B2579 IN-VEHICLE SENSOR

DTC Logic

INFOID:000000011136136

DTC DETECTION LOGIC

NOTE:

- If DTC is displayed along with DTC U1000, first perform the trouble diagnosis for DTC U1000. Refer to [HAC-86, "DTC Logic"](#).
- If DTC is displayed along with DTC U1010, first perform the trouble diagnosis for DTC U1010. Refer to [HAC-87, "DTC Logic"](#).

DTC	Items (CONSULT screen terms)	DTC detection condition	Possible cause
B2578	IN-VEHICLE SENSOR	The in-vehicle sensor recognition temperature is too high.	<ul style="list-style-type: none">• In-vehicle sensor• A/C auto amp.• Harness or connectors (The sensor circuit is open or shorted.)
B2579		The in-vehicle sensor recognition temperature is too low.	

DTC CONFIRMATION PROCEDURE

1. PERFORM DTC CONFIRMATION PROCEDURE

Ⓟ With CONSULT

1. Turn ignition switch ON.
2. Using CONSULT, perform "SELF-DIAGNOSIS RESULTS" of HVAC.
3. Check if any DTC No. is displayed in the self-diagnosis results.

Is DTC detected?

- YES >> Refer to [HAC-88, "Diagnosis Procedure"](#).
NO >> Inspection End.

Diagnosis Procedure

INFOID:000000011136137

Regarding Wiring Diagram information, refer to [HAC-51, "Wiring Diagram"](#).

1. CHECK IN-VEHICLE SENSOR POWER SUPPLY

1. Turn ignition switch OFF.
2. Disconnect in-vehicle sensor connector.
3. Turn ignition switch ON.
4. Check voltage between in-vehicle sensor harness connector and ground.

+		-	Voltage (Approx.)
In-vehicle sensor			
Connector	Terminal		
M102	1	Ground	5 V

Is the inspection result normal?

- YES >> GO TO 2.
NO >> GO TO 4.

2. CHECK IN-VEHICLE SENSOR GROUND CIRCUIT

1. Turn ignition switch OFF.
2. Check continuity between front in-vehicle sensor harness connector and ground.

B2578, B2579 IN-VEHICLE SENSOR

< DTC/CIRCUIT DIAGNOSIS >

[AUTOMATIC AIR CONDITIONING]

In-vehicle sensor		—	Continuity
Connector	Terminal		
M102	2	Ground	Yes

Is the inspection result normal?

YES >> GO TO 3.

NO >> Repair harness or connector.

3.CHECK IN-VEHICLE SENSOR

Check in-vehicle sensor. Refer to [HAC-89, "Component Inspection"](#).

Is the inspection result normal?

YES >> Replace A/C auto amp. Refer to [HAC-161, "Removal and Installation"](#).

NO >> Replace in-vehicle sensor. Refer to [HAC-163, "Removal and Installation"](#).

4.CHECK IN-VEHICLE SENSOR POWER SUPPLY CIRCUIT FOR OPEN

1. Turn ignition switch OFF.
2. Disconnect A/C auto amp. connector.
3. Check continuity between in-vehicle sensor harness connector and A/C auto amp. harness connector.

In-vehicle sensor		A/C auto amp.		Continuity
Connector	Terminal	Connector	Terminal	
M102	1	M50	27	Yes

Is the inspection result normal?

YES >> GO TO 5.

NO >> Repair harness or connector.

5.CHECK IN-VEHICLE SENSOR POWER SUPPLY CIRCUIT FOR GROUND SHORT

Check continuity between in-vehicle sensor harness connector and ground.

In-vehicle sensor		—	Continuity
Connector	Terminal		
M102	1	Ground	No

Is the inspection result normal?

YES >> GO TO 6.

NO >> Repair harness or connector.

6.CHECK IN-VEHICLE SENSOR POWER SUPPLY CIRCUIT FOR POWER SHORT

1. Turn ignition switch ON.
2. Check voltage between in-vehicle sensor harness connector and ground.

+		-	Voltage (Approx.)
In-vehicle sensor			
Connector	Terminal		
M102	1	Ground	0 V

Is the inspection result normal?

YES >> Replace A/C auto amp. Refer to [HAC-161, "Removal and Installation"](#).

NO >> Repair harness or connector.

Component Inspection

INFOID:000000011136138

1.CHECK IN-VEHICLE SENSOR

1. Turn ignition switch OFF.
2. Disconnect in-vehicle sensor connector.

B2578, B2579 IN-VEHICLE SENSOR

< DTC/CIRCUIT DIAGNOSIS >

[AUTOMATIC AIR CONDITIONING]

3. Check resistance between in-vehicle sensor terminals.

Terminal		Condition	Resistance: k Ω
		Temperature: °C (°F)	
1	2	-15 (5)	12.73
		-10 (14)	9.92
		-5 (23)	7.80
		0 (32)	6.19
		5 (41)	4.95
		10 (50)	3.99
		15 (59)	3.24
		20 (68)	2.65
		25 (77)	2.19
		30 (86)	1.81
		35 (95)	1.51
		40 (104)	1.27
		45 (113)	1.07

Is the inspection result normal?

YES >> Inspection End.

NO >> Replace in-vehicle sensor. Refer to [HAC-163. "Removal and Installation"](#).

B257B, B257C AMBIENT SENSOR

< DTC/CIRCUIT DIAGNOSIS >

[AUTOMATIC AIR CONDITIONING]

B257B, B257C AMBIENT SENSOR

DTC Logic

INFOID:0000000011136139

DTC DETECTION LOGIC

NOTE:

- If DTC is displayed along with DTC U1000, first perform the trouble diagnosis for DTC U1000. Refer to [HAC-86, "DTC Logic"](#).
- If DTC is displayed along with DTC U1010, first perform the trouble diagnosis for DTC U1010. [HAC-87, "DTC Logic"](#).

DTC	Items (CONSULT screen terms)	DTC detection condition	Possible cause
B257B	AMBIENT SENSOR	The ambient sensor recognition temperature is too high.	<ul style="list-style-type: none"> • Ambient sensor • A/C auto amp. • Harness or connectors (The sensor circuit is open or shorted.)
B257C		The ambient sensor recognition temperature is too low.	

DTC CONFIRMATION PROCEDURE

1. PERFORM DTC CONFIRMATION PROCEDURE

Ⓜ With CONSULT

1. Turn ignition switch ON.
2. Using CONSULT, perform "SELF-DIAGNOSIS RESULTS" of HVAC.
3. Check if any DTC No. is displayed in the self-diagnosis results.

Is DTC detected?

- YES >> Refer to [HAC-91, "Diagnosis Procedure"](#).
 NO >> Inspection End.

Diagnosis Procedure

INFOID:0000000011136140

Regarding Wiring Diagram information, refer to [HAC-51, "Wiring Diagram"](#).

1. CHECK AMBIENT SENSOR POWER SUPPLY

1. Turn ignition switch OFF.
2. Disconnect ambient sensor connector.
3. Turn ignition switch ON.
4. Check voltage between ambient sensor harness connector and ground.

+		-	Voltage (Approx.)
Ambient sensor			
Connector	Terminal		
E206	1	Ground	5 V

Is the inspection result normal?

- YES >> GO TO 2.
 NO >> GO TO 4.

2. CHECK AMBIENT SENSOR GROUND CIRCUIT

1. Turn ignition switch OFF.
2. Check continuity between ambient sensor harness connector and ground.

B257B, B257C AMBIENT SENSOR

< DTC/CIRCUIT DIAGNOSIS >

[AUTOMATIC AIR CONDITIONING]

Ambient sensor		—	Continuity
Connector	Terminal		
E206	2	Ground	Yes

Is the inspection result normal?

YES >> GO TO 3.

NO >> Repair harness or connector.

3.CHECK AMBIENT SENSOR

Check ambient sensor. Refer to [HAC-92, "Component Inspection"](#).

Is the inspection result normal?

YES >> Replace A/C auto amp. Refer to [HAC-161, "Removal and Installation"](#).

NO >> Replace ambient sensor. Refer to [HAC-162, "Removal and Installation"](#).

4.CHECK AMBIENT SENSOR POWER SUPPLY CIRCUIT FOR OPEN

1. Turn ignition switch OFF.
2. Disconnect A/C auto amp.connector.
3. Check continuity between ambient sensor harness connector and A/C auto amp. harness connector.

Ambient sensor		A/C auto amp.		Continuity
Connector	Terminal	Connector	Terminal	
E206	1	M50	7	Yes

Is the inspection result normal?

YES >> GO TO 5.

NO >> Repair harness or connector.

5.CHECK AMBIENT SENSOR POWER SUPPLY CIRCUIT FOR GROUND SHORT

Check continuity between ambient sensor harness connector and ground.

Ambient sensor		—	Continuity
Connector	Terminal		
E206	1	Ground	No

Is the inspection result normal?

YES >> GO TO 6.

NO >> Repair harness or connector.

6.CHECK AMBIENT SENSOR POWER SUPPLY CIRCUIT FOR POWER SHORT

1. Turn ignition switch ON.
2. Check voltage between ambient sensor harness connector and ground.

+		-	Voltage (Approx.)
Ambient sensor			
Connector	Terminal		
E206	1	Ground	0 V

Is the inspection result normal?

YES >> Replace A/C auto amp. Refer to [HAC-161, "Removal and Installation"](#).

NO >> Repair harness or connector.

Component Inspection

INFOID:000000011136141

1.CHECK AMBIENT SENSOR

1. Turn ignition switch OFF.
2. Disconnect ambient sensor connector.

B257B, B257C AMBIENT SENSOR

< DTC/CIRCUIT DIAGNOSIS >

[AUTOMATIC AIR CONDITIONING]

3. Check resistance between ambient sensor terminals.

Terminal		Condition	Resistance: kΩ
		Temperature: °C (°F)	
1	2	-15 (5)	12.73
		-10 (14)	9.92
		-5 (23)	7.80
		0 (32)	6.19
		5 (41)	4.95
		10 (50)	3.99
		15 (59)	3.24
		20 (68)	2.65
		25 (77)	2.19
		30 (86)	1.81
		35 (95)	1.51
		40 (104)	1.27
		45 (113)	1.07

Is the inspection result normal?

YES >> Inspection End.

NO >> Replace ambient sensor. Refer to [HAC-162. "Removal and Installation"](#).

A
B
C
D
E
F
G
H
J
K
L
M
N
O
P

HAC

B2581, B2582 INTAKE SENSOR

< DTC/CIRCUIT DIAGNOSIS >

[AUTOMATIC AIR CONDITIONING]

B2581, B2582 INTAKE SENSOR

DTC Logic

INFOID:000000011136142

DTC DETECTION LOGIC

NOTE:

- If DTC is displayed along with DTC U1000, first perform the trouble diagnosis for DTC U1000. Refer to [HAC-86, "DTC Logic"](#).
- If DTC is displayed along with DTC U1010, first perform the trouble diagnosis for DTC U1010. [HAC-87, "DTC Logic"](#).

DTC	Items (CONSULT screen terms)	DTC detection condition	Possible cause
B2581	INTAKE SENSOR	The intake sensor recognition temperature is too high.	<ul style="list-style-type: none">• Intake sensor• A/C auto amp.• Harness or connectors (The sensor circuit is open or shorted.)
B2582		The intake sensor recognition temperature is too low.	

DTC CONFIRMATION PROCEDURE

1. PERFORM DTC CONFIRMATION PROCEDURE

Ⓟ With CONSULT

1. Turn ignition switch ON.
2. Using CONSULT, perform "SELF-DIAGNOSIS RESULTS" of HVAC.
3. Check if any DTC No. is displayed in the self-diagnosis results.

Is DTC detected?

- YES >> Refer to [HAC-94, "Diagnosis Procedure"](#).
NO >> Inspection End.

Diagnosis Procedure

INFOID:000000011136143

Regarding Wiring Diagram information, refer to [HAC-51, "Wiring Diagram"](#).

1. CHECK INTAKE SENSOR POWER SUPPLY

1. Turn ignition switch OFF.
2. Disconnect intake sensor connector.
3. Turn ignition switch ON.
4. Check voltage between intake sensor harness connector and ground.

+		-	Voltage (Approx.)
Intake sensor			
Connector	Terminal		
M103	1	Ground	5 V

Is the inspection result normal?

- YES >> GO TO 2.
NO >> GO TO 4.

2. CHECK INTAKE SENSOR GROUND CIRCUIT

1. Turn ignition switch OFF.
2. Check continuity between intake sensor harness connector and ground.

B2581, B2582 INTAKE SENSOR

< DTC/CIRCUIT DIAGNOSIS >

[AUTOMATIC AIR CONDITIONING]

Intake sensor		—	Continuity
Connector	Terminal		
M103	2	Ground	Yes

Is the inspection result normal?

- YES >> GO TO 3.
- NO >> Repair harness or connector.

3.CHECK INTAKE SENSOR

Check intake sensor. Refer to [HAC-95, "Component Inspection"](#).

Is the inspection result normal?

- YES >> Replace A/C auto amp. Refer to [HAC-161, "Removal and Installation"](#).
- NO >> Replace intake sensor. Refer to [HAC-165, "Removal and Installation"](#).

4.CHECK INTAKE SENSOR POWER SUPPLY CIRCUIT FOR OPEN

1. Turn ignition switch OFF.
2. Disconnect A/C auto amp. connector.
3. Check continuity between intake sensor harness connector and A/C auto amp. harness connector.

Intake sensor		A/C auto amp.		Continuity
Connector	Terminal	Connector	Terminal	
M103	1	M50	28	Yes

Is the inspection result normal?

- YES >> GO TO 5.
- NO >> Repair harness or connector.

5.CHECK INTAKE SENSOR POWER SUPPLY CIRCUIT FOR GROUND SHORT

Check continuity between intake sensor harness connector and ground.

Intake sensor		—	Continuity
Connector	Terminal		
M103	1	Ground	No

Is the inspection result normal?

- YES >> GO TO 6.
- NO >> Repair harness or connector.

6.CHECK INTAKE SENSOR POWER SUPPLY CIRCUIT FOR POWER SHORT

1. Turn ignition switch ON.
2. Check voltage between intake sensor harness connector and ground.

+		-	Voltage (Approx.)
Intake sensor			
Connector	Terminal		
M103	1	Ground	0 V

Is the inspection result normal?

- YES >> Replace A/C auto amp. Refer to [HAC-161, "Removal and Installation"](#).
- NO >> Repair harness or connector.

Component Inspection

INFOID:0000000011136144

1.CHECK INTAKE SENSOR

1. Turn ignition switch OFF.
2. Disconnect intake sensor connector.

B2581, B2582 INTAKE SENSOR

< DTC/CIRCUIT DIAGNOSIS >

[AUTOMATIC AIR CONDITIONING]

3. Check resistance between intake sensor terminals.

Terminal		Condition	Resistance: kΩ
		Temperature: °C (°F)	
1	2	-15 (5)	17.73
		-10 (14)	13.46
		-5 (23)	10.33
		0 (32)	8.00
		5 (41)	6.25
		10 (50)	4.93
		15 (59)	3.92
		20 (68)	3.14
		25 (77)	2.54
		30 (86)	2.06
		35 (95)	1.69
		40 (104)	1.39
		45 (113)	1.15

Is the inspection result normal?

YES >> Inspection End.

NO >> Replace intake sensor. Refer to [HAC-165. "Removal and Installation"](#).

B262A, B262B, B2657, B2658 EXHAUST GAS/OUTSIDE ODOR DETECTING SENSOR

< DTC/CIRCUIT DIAGNOSIS >

[AUTOMATIC AIR CONDITIONING]

B262A, B262B, B2657, B2658 EXHAUST GAS/OUTSIDE ODOR DETECTING SENSOR

DTC Logic

INFOID:0000000011136145

DTC DETECTION LOGIC

NOTE:

- If DTC is displayed along with DTC U1000, first perform the trouble diagnosis for DTC U1000. Refer to [HAC-86, "DTC Logic"](#).
- If DTC is displayed along with DTC U1010, first perform the trouble diagnosis for DTC U1010. [HAC-87, "DTC Logic"](#).

DTC	Items (CONSULT screen terms)	DTC detection condition	Possible cause
B262A	GAS SENSOR	Exhaust gas / outside odor detecting sensor duty ratio 15% or less.	<ul style="list-style-type: none">• Exhaust gas / outside odor detecting sensor• A/C auto amp.• Harness or connectors (The sensor circuit is open or shorted.)
B262B		Exhaust gas / outside odor detecting sensor duty ratio 85% or more.	
B2657	GAS SENSOR CIRCUIT	Exhaust gas / outside odor detecting sensor duty ratio 0%.	
B2658		Exhaust gas / outside odor detecting sensor duty ratio 100%.	

DTC CONFIRMATION PROCEDURE

1. PERFORM DTC CONFIRMATION PROCEDURE

Ⓜ With CONSULT

1. Turn ignition switch ON.
2. Using CONSULT, perform "SELF-DIAGNOSIS RESULTS" of HVAC.
3. Check if any DTC No. is displayed in the self-diagnosis results.

Is DTC detected?

- YES >> Refer to [HAC-97, "Diagnosis Procedure"](#).
NO >> Inspection End.

Diagnosis Procedure

INFOID:0000000011136146

Regarding Wiring Diagram information, refer to [HAC-51, "Wiring Diagram"](#).

1. CHECK FUSE

1. Turn ignition switch OFF.
2. Check 10A fuse [No. 30, located in fuse block (J/B)]

NOTE:

Refer to [PG-84, "Terminal Arrangement"](#).

Is the inspection result normal?

- YES >> GO TO 2.
NO >> If a fuse is blown, be sure to eliminate cause of malfunction before installing new fuse.

2. CHECK EXHAUST GAS / OUTSIDE ODOR DETECTING SENSOR POWER SUPPLY

1. Turn ignition switch OFF.
2. Disconnect exhaust gas / outside odor detecting sensor connector.
3. Turn ignition switch ON.
4. Check voltage between exhaust gas / outside odor detecting sensor harness and ground.

B262A, B262B, B2657, B2658 EXHAUST GAS/OUTSIDE ODOR DETECTING SENSOR

< DTC/CIRCUIT DIAGNOSIS >

[AUTOMATIC AIR CONDITIONING]

+		-	Voltage (Approx.)
Exhaust gas / outside odor detecting sensor			
Connector	Terminal		
E227	1	Ground	Battery voltage

Is the inspection result normal?

YES >> GO TO 3.

NO >> Repair harness or connector between exhaust gas / outside odor detecting sensor and fuse block (J/B).

3. CHECK EXHAUST GAS / OUTSIDE ODOR DETECTING SENSOR GROUND CIRCUIT

1. Turn ignition switch OFF.
2. Check continuity between exhaust gas / outside odor detecting sensor harness connector and ground.

Exhaust gas / outside odor detecting sensor		—	Continuity
Connector	Terminal		
E227	2	Ground	Yes

Is the inspection result normal?

YES >> GO TO 4.

NO >> Repair harness or connector.

4. CHECK EXHAUST GAS / OUTSIDE ODOR DETECTING SENSOR SIGNAL CIRCUIT

1. Turn ignition switch ON.
2. Check voltage between exhaust gas / outside odor detecting sensor harness connector and ground.

+		-	Voltage (Approx.)
Exhaust gas / outside odor detecting sensor			
Connector	Terminal		
E227	3	Ground	Battery voltage

Is the inspection result normal?

YES >> Replace exhaust gas / outside odor detecting sensor. Refer to [HAC-166, "Removal and Installation"](#).

NO >> GO TO 5.

5. CHECK EXHAUST GAS / OUTSIDE ODOR DETECTING SENSOR SIGNAL CIRCUIT FOR OPEN

1. Turn ignition switch OFF.
2. Disconnect A/C auto amp. connector.
3. Check continuity between exhaust gas / outside odor detecting sensor harness connector and A/C auto amp. connector.

Exhaust gas / outside odor detecting sensor		A/C auto amp.		Continuity
Connector	Terminal	Connector	Terminal	
E227	3	M50	30	Yes

Is the inspection result normal?

YES >> GO TO 6.

NO >> Repair harness or connector.

6. CHECK EXHAUST GAS / OUTSIDE ODOR DETECTING SENSOR SIGNAL CIRCUIT FOR GROUND SHORT

Check continuity between exhaust gas / outside odor detecting sensor harness connector and ground.

B262A, B262B, B2657, B2658 EXHAUST GAS/OUTSIDE ODOR DETECTING SENSOR

< DTC/CIRCUIT DIAGNOSIS >

[AUTOMATIC AIR CONDITIONING]

Exhaust gas / outside odor detecting sensor		—	Continuity
Connector	Terminal		
E227	3	Ground	No

A

B

Is the inspection result normal?

YES >> GO TO 7.

NO >> Repair harness or connector.

C

7. CHECK EXHAUST GAS / OUTSIDE ODOR DETECTING SENSOR SIGNAL CIRCUIT FOR POWER SHORT

D

Check voltage between exhaust gas / outside odor detecting sensor harness and ground.

+			
Exhaust gas / outside odor detecting sensor		-	Voltage (Approx.)
Connector	Terminal		
E227	3	Ground	0 V

E

F

Is the inspection result normal?

YES >> Replace A/C auto amp. Refer to [HAC-161, "Removal and Installation"](#).

NO >> Repair harness or connector.

G

H

HAC

J

K

L

M

N

O

P

B2630, B2631 SUNLOAD SENSOR

< DTC/CIRCUIT DIAGNOSIS >

[AUTOMATIC AIR CONDITIONING]

B2630, B2631 SUNLOAD SENSOR

DTC Logic

INFOID:0000000011136147

DTC DETECTION LOGIC

NOTE:

- If DTC is displayed along with DTC U1000 or U1010, first diagnose the DTC U1000 or U1010. Refer to [HAC-86. "DTC Logic"](#) or [HAC-87. "DTC Logic"](#).
- Sunload sensor may register a malfunction when indoors, at dusk, or at other times when light is insufficient. When performing the diagnosis indoors, light the sunload sensor with a lamp (60W or more).

DTC	Items (CONSULT screen terms)	Diagnostic item is detected when...	Possible cause
B2630	SUNLOAD SEN (SHORT)	Detected calorie at sunload sensor 1395 w/m ² (1200 kcal/m ² ·h) or more	• Sunload sensor • A/C auto amp. • Harness and connector (Sunload sensor circuit is open, or there is a short in the circuit)
B2631	SUNLOAD SEN (OPEN)	Detected calorie at sunload sensor 0 w/m ² (0 kcal/m ² ·h)	

DTC CONFIRMATION PROCEDURE

1. CHECK WITH SELF-DIAGNOSIS FUNCTION OF CONSULT

1. Using CONSULT, perform "SELF-DIAGNOSIS RESULTS" of HVAC.
2. Check if any DTC No. is displayed in the self-diagnosis results.

NOTE:

- If DTC is displayed along with DTC U1000 or U1010, first diagnose the DTC U1000 or U1010. Refer to [HAC-86. "DTC Logic"](#) or [HAC-87. "DTC Logic"](#).
- Sunload sensor may register a malfunction when indoors, at dusk, or at other times when light is insufficient. When performing the diagnosis indoors, light the sunload sensor with a lamp (60W or more).

Is DTC No. "B2630" or "B2631" displayed?

- YES >> Perform trouble diagnosis for the sunload sensor. Refer to [HAC-100. "Diagnosis Procedure"](#).
NO >> Inspection End.

Diagnosis Procedure

INFOID:0000000011136148

Regarding Wiring Diagram information, refer to [HAC-51. "Wiring Diagram"](#).

1. CHECK SUNLOAD SENSOR POWER SUPPLY

1. Disconnect sunload sensor connector.
2. Turn ignition switch ON.
3. Check voltage between sunload sensor harness connector M101 terminal 1 and ground.

+		-	Voltage (Approx.)
Connector	Terminal		
M101	1	Ground	5 V

Is the inspection result normal?

- YES >> GO TO 2.
NO >> GO TO 4.

2. CHECK CONTINUITY BETWEEN SUNLOAD SENSOR AND A/C AUTO AMP.

1. Turn ignition switch OFF.
2. Disconnect A/C auto amp. connector.

B2630, B2631 SUNLOAD SENSOR

[AUTOMATIC AIR CONDITIONING]

< DTC/CIRCUIT DIAGNOSIS >

3. Check continuity between sunload sensor harness connector M101 terminal 2 and A/C auto amp. harness connector M50 terminal 26.

Sunload sensor		A/C auto amp.		Continuity
Connector	Terminal	Connector	Terminal	
M101	2	M50	26	Yes

Is the inspection result normal?

YES >> GO TO 3.

NO >> Repair harness or connector.

3.CHECK SUNLOAD SENSOR

1. Reconnect sunload sensor connector and A/C auto amp. connector.
2. Check sunload sensor. Refer to [HAC-101, "Component Inspection"](#).

Is the inspection result normal?

YES >> Replace A/C auto amp. Refer to [HAC-161, "Removal and Installation"](#).

NO >> Replace sunload sensor. Refer to [HAC-164, "Removal and Installation"](#).

4.CHECK CONTINUITY BETWEEN SUNLOAD SENSOR AND A/C AUTO AMP.

1. Turn ignition switch OFF.
2. Disconnect A/C auto amp. connector.
3. Check continuity between sunload sensor harness connector M101 terminal 1 and A/C auto amp. harness connector M50 terminal 9.

Sunload sensor		A/C auto amp.		Continuity
Connector	Terminal	Connector	Terminal	
M101	1	M50	9	Yes

4. Check continuity between sunload sensor harness connector M101 terminal 1 and ground.

Sunload sensor		—	Continuity
Connector	Terminal		
M101	1	Ground	No

Is the inspection result normal?

YES >> Replace A/C auto amp. Refer to [HAC-161, "Removal and Installation"](#).

NO >> Repair harness or connector.

Component Inspection

INFOID:000000011136149

1.CHECK SUNLOAD SENSOR

1. Turn ignition switch ON.
2. Check voltage between A/C auto amp. harness connector and ground.

(+)		(-)	
A/C auto amp.		—	
Connector	Terminal		
M50	9	Ground	

B2630, B2631 SUNLOAD SENSOR

< DTC/CIRCUIT DIAGNOSIS >

[AUTOMATIC AIR CONDITIONING]

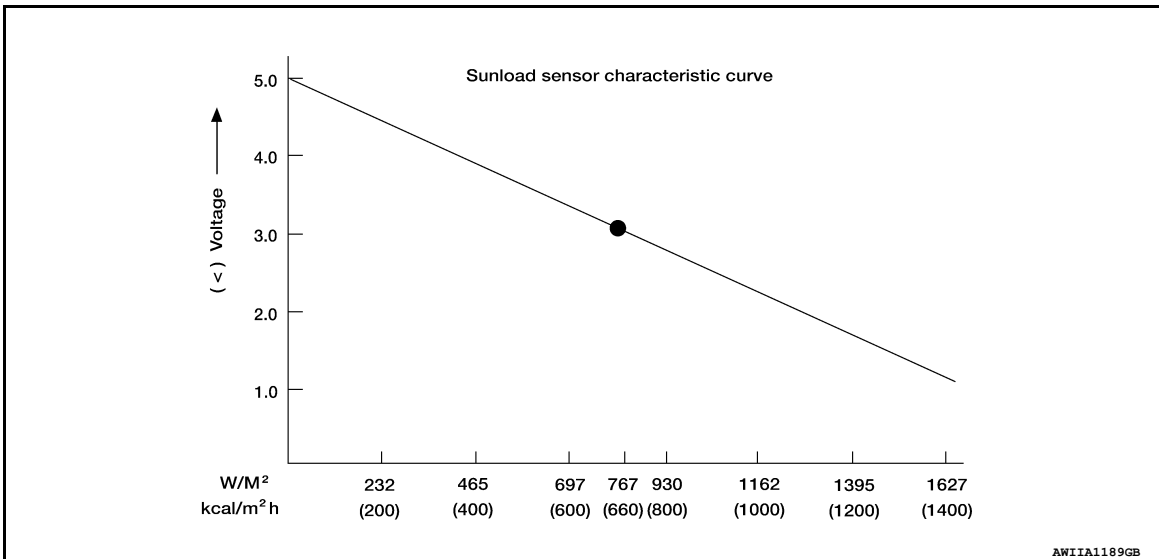

NOTE:

Select a place in direct sunlight when checking sunload sensor.

Is the inspection result normal?

YES >> Inspection End.

NO >> Replace sunload sensor. Refer to [HAC-164, "Removal and Installation"](#).

B2632, B2633 AIR MIX DOOR MOTOR (DRIVER SIDE)

< DTC/CIRCUIT DIAGNOSIS >

[AUTOMATIC AIR CONDITIONING]

B2632, B2633 AIR MIX DOOR MOTOR (DRIVER SIDE)

DTC Logic

INFOID:000000011136150

DTC DETECTION LOGIC

DTC	Items (CONSULT screen terms)	DTC detection condition	Possible cause
B2632	DR AIR MIX DOOR MOT	Air mix door motor (driver side) PBR position 95% or more	<ul style="list-style-type: none"> Air mix door motor (driver side) (PBR internal circuit is open or shorted) Air mix door motor (driver side) installation condition A/C auto amp. Harness and connector (LIN communication line is open or shorted)
B2633		Air mix door motor (driver side) PBR position 5% or less	

DTC CONFIRMATION PROCEDURE

1. PERFORM DTC CONFIRMATION PROCEDURE

④ With CONSULT

- Turn ignition switch ON.
- Using CONSULT, perform "SELF-DIAGNOSIS RESULTS" of HVAC.
- Check if any DTC No. is displayed in the self-diagnosis results.

Is DTC detected?

- YES >> Refer to [HAC-103, "Diagnosis Procedure"](#).
 NO >> Inspection End.

Diagnosis Procedure

INFOID:000000011136151

Regarding Wiring Diagram information, refer to [HAC-51, "Wiring Diagram"](#).

1. CHECK AIR MIX DOOR MOTOR (DRIVER SIDE) COMMUNICATION SIGNAL

- Turn ignition switch ON.
- Check output waveform between air mix door motor (driver side) harness connector and ground with the oscilloscope.

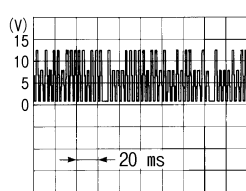
+		-	Output waveform
Air mix door motor (driver side) Connector	Terminal		
M130	2	Ground	 <p style="text-align: right;">SJIA1453J</p>

Is the inspection result normal?

- YES >> GO TO 2.
 NO >> GO TO 3.

2. CHECK INSTALLATION OF AIR MIX DOOR MOTOR (DRIVER SIDE)

Check air mix door motor (driver side) is properly installed. Refer to [HAC-168, "Exploded View"](#).

B2632, B2633 AIR MIX DOOR MOTOR (DRIVER SIDE)

< DTC/CIRCUIT DIAGNOSIS >

[AUTOMATIC AIR CONDITIONING]

Is the inspection result normal?

YES >> Replace air mix door motor (driver side). Refer to [HAC-170, "AIR MIX DOOR MOTOR : Removal and Installation - Air Mix Door Motor \(Driver Side\)"](#).

NO >> Repair or replace malfunctioning part.

3. CHECK AIR MIX DOOR MOTOR (DRIVER SIDE) COMMUNICATION SIGNAL CIRCUIT

1. Turn ignition switch OFF.
2. Disconnect air mix door motor (driver side) and A/C auto amp. connector.
3. Check continuity between air mix door motor (driver side) harness connector and A/C auto amp. harness connector.

Air mix door motor (driver side)		A/C auto amp.		Continuity
Connector	Terminal	Connector	Terminal	
M130	2	M50	16	Yes

Is the inspection result normal?

YES >> Replace A/C auto amp. Refer to [HAC-161, "Removal and Installation"](#).

NO >> Repair harness or connector.

B2634, B2635 AIR MIX DOOR MOTOR (PASSENGER SIDE)

< DTC/CIRCUIT DIAGNOSIS >

[AUTOMATIC AIR CONDITIONING]

B2634, B2635 AIR MIX DOOR MOTOR (PASSENGER SIDE)

DTC Logic

INFOID:000000011136152

DTC DETECTION LOGIC

DTC	Items (CONSULT screen terms)	DTC detection condition	Possible cause
B2634	PASS AIR MIX DOOR MOT	Air mix door motor (passenger side) PBR position 95% or more	<ul style="list-style-type: none"> Air mix door motor (passenger side) (PBR internal circuit is open or shorted) Air mix door motor (passenger side) installation condition A/C auto amp. Harness and connector (LIN communication line is open or shorted)
B2635		Air mix door motor (passenger side) PBR position 5% or less	

DTC CONFIRMATION PROCEDURE

1. PERFORM DTC CONFIRMATION PROCEDURE

With CONSULT

- Turn ignition switch ON.
- Using CONSULT, perform "SELF-DIAGNOSIS RESULTS" of HVAC.
- Check if any DTC No. is displayed in the self-diagnosis results.

Is DTC detected?

- YES >> Refer to [HAC-105. "Diagnosis Procedure"](#).
 NO >> Inspection End.

Diagnosis Procedure

INFOID:000000011136153

Regarding Wiring Diagram information, refer to [HAC-51. "Wiring Diagram"](#).

1. CHECK AIR MIX DOOR MOTOR (PASSENGER SIDE) COMMUNICATION SIGNAL

- Turn ignition switch ON.
- Check output waveform between front air mix door motor RH harness connector and ground with the oscilloscope.

+		-	Output waveform
Connector	Terminal		
M131	2	Ground	<p style="text-align: right;">SJIA1453J</p>

Is the inspection result normal?

- YES >> GO TO 2.
 NO >> GO TO 3.

2. CHECK INSTALLATION OF AIR MIX DOOR MOTOR (PASSENGER SIDE)

Check air mix door motor (passenger side) is properly installed. Refer to [HAC-168. "Exploded View"](#).

B2634, B2635 AIR MIX DOOR MOTOR (PASSENGER SIDE)

< DTC/CIRCUIT DIAGNOSIS >

[AUTOMATIC AIR CONDITIONING]

Is the inspection result normal?

YES >> Replace air mix door motor (passenger side). Refer to [HAC-170, "AIR MIX DOOR MOTOR : Removal and Installation - Air Mix Door Motor \(Passenger Side\)"](#).

NO >> Repair or replace malfunctioning part.

3. CHECK AIR MIX DOOR MOTOR (PASSENGER SIDE) COMMUNICATION SIGNAL CIRCUIT

1. Turn ignition switch OFF.
2. Disconnect air mix door motor (passenger side) and A/C auto amp. connector.
3. Check continuity between air mix door motor (passenger side) harness connector and A/C auto amp. harness connector.

Air mix door motor (passenger side)		A/C auto amp.		Continuity
Connector	Terminal	Connector	Terminal	
M131	2	M50	16	Yes

Is the inspection result normal?

YES >> Replace A/C auto amp. Refer to [HAC-161, "Removal and Installation"](#).

NO >> Repair harness or connector.

B2636, B2637, B2638, B2639, B2654 MODE DOOR MOTOR (FRONT)

< DTC/CIRCUIT DIAGNOSIS >

[AUTOMATIC AIR CONDITIONING]

B2636, B2637, B2638, B2639, B2654 MODE DOOR MOTOR (FRONT)

DTC Logic

INFOID:0000000011136154

DTC DETECTION LOGIC

DTC	Items (CONSULT screen terms)	DTC detection condition	Possible cause
B2636	DR VENT DOOR FAIL	When the malfunctioning door position is detected at VENT position	<ul style="list-style-type: none"> Mode door motor (front) (PBR internal circuit is open or shorted) Mode door motor (front) control linkage installation condition A/C auto amp. Harness and connector (LIN communication line is open or shorted)
B2637	DR B/L DOOR FAIL	When the malfunctioning door position is detected at B/L position	
B2638	DR D/F1 DOOR FAIL	When the malfunctioning door position is detected at FOOT position	
B2639	DR DEF DOOR FAIL	When the malfunctioning door position is detected at DEF position	
B2654	D/F2 VENT DOOR FAIL	When the malfunctioning door position is detected at D/F position	

DTC CONFIRMATION PROCEDURE

1. PERFORM DTC CONFIRMATION PROCEDURE

Ⓜ With CONSULT

- Turn ignition switch ON.
- Using CONSULT, perform "SELF-DIAGNOSIS RESULTS" of HVAC.
- Check if any DTC No. is displayed in the self-diagnosis results.

Is DTC detected?

- YES >> Refer to [HAC-107, "Diagnosis Procedure"](#).
 NO >> Inspection End.

Diagnosis Procedure

INFOID:0000000011136155

Regarding Wiring Diagram information, refer to [HAC-51, "Wiring Diagram"](#).

1. CHECK MODE DOOR MOTOR (FRONT) COMMUNICATION SIGNAL

- Turn ignition switch ON.
- Check output waveform between mode door motor (front) harness connector and ground with the oscilloscope.

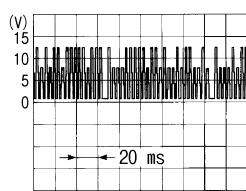
+		-	Output waveform
Mode door motor (front)			
Connector	Terminal		
M129	2	Ground	 <p style="text-align: right;">SJIA1453J</p>

Is the inspection result normal?

- YES >> GO TO 2.
 NO >> GO TO 3.

B2636, B2637, B2638, B2639, B2654 MODE DOOR MOTOR (FRONT)

< DTC/CIRCUIT DIAGNOSIS >

[AUTOMATIC AIR CONDITIONING]

2. CHECK INSTALLATION OF MODE DOOR MOTOR (FRONT)

Check mode door motor (front) is properly installed. Refer to [HAC-168, "Exploded View"](#).

Is the inspection result normal?

YES >> Replace mode door motor (front). Refer to [HAC-169, "MODE DOOR MOTOR : Removal and Installation - Mode Door Motor \(Front\)"](#).

NO >> Repair or replace malfunctioning part.

3. CHECK MODE DOOR MOTOR (FRONT) COMMUNICATION SIGNAL CIRCUIT

1. Turn ignition switch OFF.
2. Disconnect mode door motor (front) and A/C auto amp. connector.
3. Check continuity between mode door motor (front) harness connector and A/C auto amp. harness connector.

Mode door motor (front)		A/C auto amp.		Continuity
Connector	Terminal	Connector	Terminal	
M129	2	M50	16	Yes

Is the inspection result normal?

YES >> Replace A/C auto amp. Refer to [HAC-161, "Removal and Installation"](#).

NO >> Repair harness or connector.

B263D, B263E, B263F INTAKE DOOR MOTOR

< DTC/CIRCUIT DIAGNOSIS >

[AUTOMATIC AIR CONDITIONING]

B263D, B263E, B263F INTAKE DOOR MOTOR

DTC Logic

INFOID:0000000011136156

DTC DETECTION LOGIC

DTC	Items (CONSULT screen terms)	DTC detection condition	Possible cause
B263D	FRE DOOR FAIL	When the malfunctioning intake door position is detected at FRE position	<ul style="list-style-type: none"> Intake door motor (PBR internal circuit is open or shorted) A/C auto amp. Harness and connector (LIN communication line is open or shorted)
B263E	20P FRE DOOR FAIL	When the malfunctioning intake door position is detected at 20% FRE position	
B263F	REC DOOR FAIL	When the malfunctioning intake door position is detected at REC position	

DTC CONFIRMATION PROCEDURE

1. PERFORM DTC CONFIRMATION PROCEDURE

Ⓜ With CONSULT

- Turn ignition switch ON.
- Using CONSULT, perform "SELF-DIAGNOSIS RESULTS" of HVAC.
- Check if any DTC No. is displayed in the self-diagnosis results.

Is DTC detected?

- YES >> Refer to [HAC-109. "Diagnosis Procedure"](#).
 NO >> Inspection End.

Diagnosis Procedure

INFOID:0000000011136157

HAC

Regarding Wiring Diagram information, refer to [HAC-51. "Wiring Diagram"](#).

1. CHECK INTAKE DOOR MOTOR COMMUNICATION SIGNAL

- Turn ignition switch ON.
- Check output waveform between intake door motor harness connector and ground with the oscilloscope.

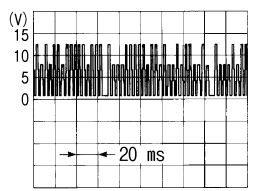
+		-	Output waveform
Intake door motor Connector	Terminal		
M128	2	Ground	 <p style="text-align: right;">SJIA1453J</p>

Is the inspection result normal?

- YES >> GO TO 2.
 NO >> GO TO 3.

2. CHECK INSTALLATION OF INTAKE DOOR MOTOR

Check intake door motor is properly installed. Refer to [HAC-168. "Exploded View"](#).

Is the inspection result normal?

B263D, B263E, B263F INTAKE DOOR MOTOR

< DTC/CIRCUIT DIAGNOSIS >

[AUTOMATIC AIR CONDITIONING]

- YES >> Replace intake door motor. Refer to [HAC-170, "INTAKE DOOR MOTOR : Removal and Installation"](#).
- NO >> Repair or replace malfunctioning part.

3. CHECK INTAKE DOOR MOTOR COMMUNICATION SIGNAL CIRCUIT

1. Turn ignition switch OFF.
2. Disconnect intake door motor and A/C auto amp. connector.
3. Check continuity between intake door motor harness connector and A/C auto amp. harness connector.

Intake door motor		A/C auto amp.		Continuity
Connector	Terminal	Connector	Terminal	
M128	2	M50	16	Yes

Is the inspection result normal?

- YES >> Replace A/C auto amp. Refer to [HAC-161, "Removal and Installation"](#).
- NO >> Repair harness or connector.

B2799, B279A AIR MIX DOOR MOTOR (REAR)

< DTC/CIRCUIT DIAGNOSIS >

[AUTOMATIC AIR CONDITIONING]

B2799, B279A AIR MIX DOOR MOTOR (REAR)

DTC Logic

INFOID:000000011136158

DTC DETECTION LOGIC

DTC	Items (CONSULT screen terms)	DTC detection condition	Possible cause
B2664	REAR AIR MIX DOOR MOT	Air mix door motor (rear) PBR position 95% or more	<ul style="list-style-type: none"> Air mix door motor (rear) (PBR internal circuit is open or shorted) Air mix door motor (rear) installation condition A/C auto amp. Harness and connector (LIN communication line is open or shorted)
B2665		Air mix door motor (rear) PBR position 5% or less	

DTC CONFIRMATION PROCEDURE

1. PERFORM DTC CONFIRMATION PROCEDURE

④ With CONSULT

- Turn ignition switch ON.
- Using CONSULT, perform "SELF-DIAGNOSIS RESULTS" of HVAC.
- Check if any DTC No. is displayed in the self-diagnosis results.

Is DTC detected?

- YES >> Refer to [HAC-111, "Diagnosis Procedure"](#).
 NO >> Inspection End.

Diagnosis Procedure

INFOID:000000011136159

Regarding Wiring Diagram information, refer to [HAC-51, "Wiring Diagram"](#).

1. CHECK AIR MIX DOOR MOTOR (REAR) COMMUNICATION SIGNAL

- Turn ignition switch ON.
- Check output waveform between air mix door motor (rear) harness connector and ground with the oscilloscope.

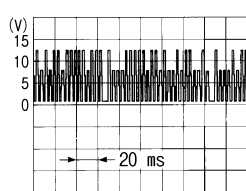
+		-	Output waveform
Air mix door motor (rear) Connector	Terminal		
M132	2	Ground	 <p style="text-align: right;">SJIA1453J</p>

Is the inspection result normal?

- YES >> GO TO 2.
 NO >> GO TO 3.

2. CHECK INSTALLATION OF AIR MIX DOOR MOTOR (REAR)

Check air mix door motor (rear) is properly installed. Refer to [HAC-168, "Exploded View"](#).

B2799, B279A AIR MIX DOOR MOTOR (REAR)

[AUTOMATIC AIR CONDITIONING]

< DTC/CIRCUIT DIAGNOSIS >

Is the inspection result normal?

YES >> Replace air mix door motor (rear). Refer to [HAC-170, "AIR MIX DOOR MOTOR : Removal and Installation - Air Mix Door Motor \(Rear\)"](#).

NO >> Repair or replace malfunctioning part.

3. CHECK AIR MIX DOOR MOTOR (REAR) COMMUNICATION SIGNAL CIRCUIT

1. Turn ignition switch OFF.
2. Disconnect air mix door motor (rear) and A/C auto amp. connector.
3. Check continuity between air mix door motor (rear) harness connector and A/C auto amp. harness connector.

Air mix door motor (rear)		A/C auto amp.		Continuity
Connector	Terminal	Connector	Terminal	
M132	2	M50	16	Yes

Is the inspection result normal?

YES >> Replace A/C auto amp. Refer to [HAC-161, "Removal and Installation"](#).

NO >> Repair harness or connector.

B279B, B279C MODE DOOR MOTOR (REAR)

< DTC/CIRCUIT DIAGNOSIS >

[AUTOMATIC AIR CONDITIONING]

B279B, B279C MODE DOOR MOTOR (REAR)

DTC Logic

INFOID:0000000011136160

DTC DETECTION LOGIC

DTC	Items (CONSULT screen terms)	DTC detection condition	Possible cause
B279B	REAR MODE DOOR MOT	When the malfunctioning door position is detected at VENT position	<ul style="list-style-type: none"> Mode door motor (rear) (PBR internal circuit is open or shorted) A/C auto amp. Harness and connector (LIN communication line is open or shorted)
B279C		When the malfunctioning door position is detected at FOOT position	

DTC CONFIRMATION PROCEDURE

1. PERFORM DTC CONFIRMATION PROCEDURE

Ⓜ With CONSULT

- Turn ignition switch ON.
- Using CONSULT, perform "SELF-DIAGNOSIS RESULTS" of HVAC.
- Check if any DTC No. is displayed in the self-diagnosis results.

Is DTC detected?

- YES >> Refer to [HAC-113, "Diagnosis Procedure"](#).
 NO >> Inspection End.

Diagnosis Procedure

INFOID:0000000011136161

HAC

Regarding Wiring Diagram information, refer to [HAC-51, "Wiring Diagram"](#).

1. CHECK MODE DOOR MOTOR (REAR) COMMUNICATION SIGNAL

- Turn ignition switch ON.
- Check output waveform between mode door motor (rear) harness connector and ground with the oscilloscope.

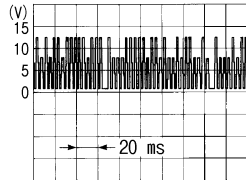
+		-	Output waveform
Mode door motor (rear)			
Connector	Terminal		
M13	2	Ground	 <p style="text-align: right; font-size: small;">SJIA1453J</p>

Is the inspection result normal?

- YES >> GO TO 2.
 NO >> GO TO 3.

2. CHECK INSTALLATION OF MODE DOOR MOTOR (REAR)

Check mode door motor (rear) is properly installed. Refer to [HAC-168, "Exploded View"](#).

Is the inspection result normal?

B279B, B279C MODE DOOR MOTOR (REAR)

[AUTOMATIC AIR CONDITIONING]

< DTC/CIRCUIT DIAGNOSIS >

- YES >> Replace mode door motor (rear). Refer to [HAC-169. "MODE DOOR MOTOR : Removal and Installation - Mode Door Motor \(Rear\)".](#)
- NO >> Repair or replace malfunctioning part.

3. CHECK MODE DOOR MOTOR (REAR) COMMUNICATION SIGNAL CIRCUIT

1. Turn ignition switch OFF.
2. Disconnect mode door motor (rear) and A/C auto amp. connector.
3. Check continuity between mode door motor (rear) harness connector and A/C auto amp. harness connector.

Mode door motor (rear)		A/C auto amp.		Continuity
Connector	Terminal	Connector	Terminal	
M13	2	M50	16	Yes

Is the inspection result normal?

- YES >> Replace A/C auto amp. Refer to [HAC-161. "Removal and Installation".](#)
- NO >> Repair harness or connector.

B279D, B279E REAR SHUT-OFF DOOR MOTOR

< DTC/CIRCUIT DIAGNOSIS >

[AUTOMATIC AIR CONDITIONING]

B279D, B279E REAR SHUT-OFF DOOR MOTOR

DTC Logic

INFOID:0000000011136162

DTC DETECTION LOGIC

DTC	Items (CONSULT screen terms)	DTC detection condition	Possible cause
B279D	REAR SHUT DOOR MOT	When the malfunctioning door position is detected at open position	<ul style="list-style-type: none"> Rear shut door motor (PBR internal circuit is open or shorted) A/C auto amp. Harness and connector (LIN communication line is open or shorted)
B279E		When the malfunctioning door position is detected at closed position	

DTC CONFIRMATION PROCEDURE

1. PERFORM DTC CONFIRMATION PROCEDURE

Ⓜ With CONSULT

- Turn ignition switch ON.
- Using CONSULT, perform "SELF-DIAGNOSIS RESULTS" of HVAC.
- Check if any DTC No. is displayed in the self-diagnosis results.

Is DTC detected?

- YES >> Refer to [HAC-115, "Diagnosis Procedure"](#).
 NO >> Inspection End.

Diagnosis Procedure

INFOID:0000000011136163

HAC

Regarding Wiring Diagram information, refer to [HAC-51, "Wiring Diagram"](#).

1. CHECK REAR SHUT-OFF DOOR MOTOR COMMUNICATION SIGNAL

- Turn ignition switch ON.
- Check output waveform between rear shut-off door motor harness connector and ground with the oscilloscope.

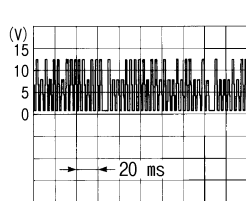
+		-	Output waveform
Connector	Terminal		
M12	2	Ground	 <p style="text-align: right;">SJIA1453J</p>

Is the inspection result normal?

- YES >> GO TO 2.
 NO >> GO TO 3.

2. CHECK INSTALLATION OF REAR SHUT-OFF DOOR MOTOR

Check rear shut-off door motor is properly installed. Refer to [HAC-168, "Exploded View"](#).

Is the inspection result normal?

B279D, B279E REAR SHUT-OFF DOOR MOTOR

[AUTOMATIC AIR CONDITIONING]

< DTC/CIRCUIT DIAGNOSIS >

- YES >> Replace shut-off door motor. Refer to [HAC-170. "REAR SHUT-OFF DOOR MOTOR : Removal and Installation"](#).
- NO >> Repair or replace malfunctioning part.

3. CHECK REAR SHUT-OFF DOOR MOTOR COMMUNICATION SIGNAL CIRCUIT

1. Turn ignition switch OFF.
2. Disconnect rear shut-off door motor and A/C auto amp. connector.
3. Check continuity between rear shut-off door motor harness connector and A/C auto amp. harness connector.

Rear shut-off door motor		A/C auto amp.		Continuity
Connector	Terminal	Connector	Terminal	
M12	2	M50	16	Yes

Is the inspection result normal?

- YES >> Replace A/C auto amp. Refer to [HAC-161. "Removal and Installation"](#).
- NO >> Repair harness or connector.

B2796, B2797, B2798 COMMUNICATION ERROR

< DTC/CIRCUIT DIAGNOSIS >

[AUTOMATIC AIR CONDITIONING]

B2796, B2797, B2798 COMMUNICATION ERROR

DTC Logic

INFOID:000000011136164

DTC DETECTION LOGIC

DTC	Items (CONSULT screen terms)	DTC detection condition	Possible cause
B2796	Communication error	When A/C auto amp. is not transmitting or receiving communication signal for 2 or more seconds.	<ul style="list-style-type: none"> • Rear control unit • A/C auto amp. • Harness and connector (Communication line is open or shorted)
B2797		When display unit is not transmitting or receiving communication signal for 2 or more seconds.	
B2798		When rear control unit is not transmitting or receiving communication signal for 2 or more seconds.	

DTC CONFIRMATION PROCEDURE

1. PERFORM DTC CONFIRMATION PROCEDURE

Ⓜ With CONSULT

1. Turn ignition switch ON.
2. Using CONSULT, perform "SELF-DIAGNOSIS RESULTS" of HVAC.
3. Check if any DTC No. is displayed in the self-diagnosis results.

Is DTC detected?

- YES >> Refer to [HAC-117. "Diagnosis Procedure"](#).
 NO >> Inspection End.

Diagnosis Procedure

INFOID:000000011136165

Regarding Wiring Diagram information, refer to [HAC-51. "Wiring Diagram"](#).

1. CHECK COMMUNICATION SIGNAL CIRCUIT (A/C AUTO AMP. → REAR AIR CONTROL) FOR OPEN

1. Turn ignition switch OFF.
2. Disconnect rear air control and A/C auto amp. connector.
3. Check continuity between rear air control harness connector and A/C auto amp. harness connector.

Rear air control		A/C auto amp.		Continuity
Connector	Terminal	Connector	Terminal	
M258	9	M50	5	Yes

Is the inspection result normal?

- YES >> GO TO 2.
 NO >> Repair harness or connector.

2. CHECK COMMUNICATION SIGNAL CIRCUIT (A/C AUTO AMP. → REAR AIR CONTROL) FOR SHORT

Check continuity between rear air control harness connector and ground.

Rear air control		—	Continuity
Connector	Terminal		
M258	9	Ground	No

Is the inspection result normal?

- YES >> GO TO 3.

A
B
C
D
E
F
G
H
I
J
K
L
M
N
O
P



B2796, B2797, B2798 COMMUNICATION ERROR

< DTC/CIRCUIT DIAGNOSIS >

[AUTOMATIC AIR CONDITIONING]

NO >> Repair harness or connector.

3. CHECK COMMUNICATION SIGNAL CIRCUIT (REAR AIR CONTROL → A/C AUTO AMP.) CIRCUIT FOR OPEN

Check continuity between rear air control harness connector and A/C auto amp. harness connector.

Rear air control		A/C auto amp.		Continuity
Connector	Terminal	Connector	Terminal	
M258	10	M50	25	Yes

Is the inspection result normal?

YES >> GO TO 4.

NO >> Repair harness or connector.

4. CHECK COMMUNICATION SIGNAL CIRCUIT (REAR AIR CONTROL → A/C AUTO AMP.) CIRCUIT FOR SHORT

Check continuity between rear air control harness connector and ground.

Rear air control		—	Continuity
Connector	Terminal		
M258	10	Ground	No

Is the inspection result normal?

YES >> Replace A/C auto amp. Refer to [HAC-161, "Removal and Installation"](#).

NO >> Repair harness or connector.

B27B0 A/C AUTO AMP.

< DTC/CIRCUIT DIAGNOSIS >

[AUTOMATIC AIR CONDITIONING]

B27B0 A/C AUTO AMP.

DTC Logic

INFOID:0000000011136166

DTC DETECTION LOGIC

NOTE:

- If DTC is displayed along with DTC U1000, first perform the trouble diagnosis for DTC U1000. Refer to [HAC-86, "DTC Logic"](#).
- If DTC is displayed along with DTC U1010, first perform the trouble diagnosis for DTC U1010. [HAC-87, "DTC Logic"](#).

DTC	Items (CONSULT screen terms)	DTC detection condition	Possible cause
B27B0	A/C AUTO AMP.	A/C auto amp. EEPROM system is malfunctioning.	A/C auto amp.

DTC CONFIRMATION PROCEDURE

1. PERFORM DTC CONFIRMATION PROCEDURE

With CONSULT

1. Turn ignition switch ON.
2. Using CONSULT, perform "SELF-DIAGNOSIS RESULTS" of HVAC.
3. Check if any DTC No. is displayed in the self-diagnosis results.

Is DTC detected?

- YES >> Refer to [HAC-119, "Diagnosis Procedure"](#).
NO >> Inspection End.

Diagnosis Procedure

INFOID:0000000011136167

HAC

1. PERFORM SELF DIAGNOSTIC

With CONSULT

1. Turn ignition switch ON.
2. Select "Self Diagnostic Result" mode of "HVAC" using CONSULT.
3. Touch "ERASE".
4. Turn ignition switch OFF.
5. Turn ignition switch ON.
6. Perform "DTC CONFIRMATION PROCEDURE". Refer to [HAC-119, "DTC Logic"](#).

Is DTC detected again?

- YES >> Replace A/C auto amp. Refer to [HAC-161, "Removal and Installation"](#).
NO >> Inspection End.

POWER SUPPLY AND GROUND CIRCUIT

< DTC/CIRCUIT DIAGNOSIS >

[AUTOMATIC AIR CONDITIONING]

POWER SUPPLY AND GROUND CIRCUIT

A/C AUTO AMP.

A/C AUTO AMP. : Diagnosis Procedure

INFOID:000000011136168

Regarding Wiring Diagram information, refer to [HAC-51. "Wiring Diagram"](#).

1. CHECK FUSE

Check fuses [No. 14 and 30, located in the fuse block (J/B)].

NOTE:

Refer to [PG-84. "Terminal Arrangement"](#).

Is the inspection result normal?

YES >> GO TO 2.

NO >> Replace the blown fuse after repairing the affected circuit.

2. CHECK A/C AUTO AMP. POWER SUPPLY

1. Turn ignition switch OFF.
2. Disconnect A/C auto amp. connector.
3. Check voltage between A/C auto amp. harness connector and ground.

+		-	Voltage		
A/C auto amp.			Ignition switch position		
Connector	Terminal		OFF	ACC	ON
M50	23	Ground	Approx. 0 V	Approx. 0 V	Battery voltage
	3		Battery voltage	Battery voltage	Battery voltage

Is the inspection result normal?

YES >> GO TO 3.

NO >> Repair harness or connector between A/C auto amp. and fuse block (J/B).

3. CHECK A/C AUTO AMP. GROUND CIRCUIT

1. Turn ignition switch OFF.
2. Check continuity between A/C auto amp. harness connector and ground.

A/C auto amp.		—	Continuity
Connector	Terminal		
M50	2	Ground	Yes
	22		

Is the inspection result normal?

YES >> Inspection End.

NO >> Repair harness or connector.

AIR MIX DOOR MOTOR (DRIVER SIDE)

AIR MIX DOOR MOTOR (DRIVER SIDE) : Diagnosis Procedure

INFOID:000000011136169

Regarding Wiring Diagram information, refer to [HAC-51. "Wiring Diagram"](#).

1. CHECK AIR MIX DOOR MOTOR (DRIVER SIDE) POWER SUPPLY

1. Turn ignition switch ON.
2. Check voltage between air mix door motor (driver side) harness connector and ground.

POWER SUPPLY AND GROUND CIRCUIT

< DTC/CIRCUIT DIAGNOSIS >

[AUTOMATIC AIR CONDITIONING]

+		-	Voltage (Approx.)
Connector	Terminal		
M130	1	Ground	Battery voltage

Is the inspection result normal?

- YES >> GO TO 2.
- NO >> GO TO 4.

2. CHECK AIR MIX DOOR MOTOR (DRIVER SIDE) GROUND CIRCUIT

1. Turn ignition switch OFF.
2. Disconnect air mix door motor (driver side) connector.
3. Check continuity between air mix door motor (driver side) harness connector and ground.

Air mix door motor (driver side)		—	Continuity
Connector	Terminal		
M130	3	Ground	Yes

Is the inspection result normal?

- YES >> GO TO 3.
- NO >> Repair harness or connector.

3. CHECK INSTALLATION OF AIR MIX DOOR MOTOR (DRIVER SIDE)

Check air mix door motor (driver side) is properly installed. Refer to [HAC-168, "Exploded View"](#).

Is the inspection result normal?

- YES >> Replace air mix door motor (driver side). Refer to [HAC-170, "AIR MIX DOOR MOTOR : Removal and Installation - Air Mix Door Motor \(Driver Side\)"](#).
- NO >> Repair or replace malfunctioning part.

4. CHECK AIR MIX DOOR MOTOR (DRIVER SIDE) POWER SUPPLY CIRCUIT

1. Turn ignition switch OFF.
2. Disconnect air mix door motor (driver side) connector and A/C auto amp. connector.
3. Check continuity between air mix door motor (driver side) harness connector and A/C auto amp. harness connector.

Air mix door motor (driver side)		A/C auto amp.		Continuity
Connector	Terminal	Connector	Terminal	
M130	1	M50	17	Yes

Is the inspection result normal?

- YES >> Replace A/C auto amp. Refer to [HAC-161, "Removal and Installation"](#).
- NO >> Repair harness or connector.

AIR MIX DOOR MOTOR (PASSENGER SIDE)

AIR MIX DOOR MOTOR (PASSENGER SIDE) : Diagnosis Procedure

INFOID:000000011136170

Regarding Wiring Diagram information, refer to [HAC-51, "Wiring Diagram"](#).

1. CHECK AIR MIX DOOR MOTOR (PASSENGER SIDE) POWER SUPPLY

1. Turn ignition switch ON.
2. Check voltage between air mix door motor (passenger side) harness connector and ground.

POWER SUPPLY AND GROUND CIRCUIT

< DTC/CIRCUIT DIAGNOSIS >

[AUTOMATIC AIR CONDITIONING]

+		-	Voltage (Approx.)
Connector	Terminal		
M131	1	Ground	Battery voltage

Is the inspection result normal?

- YES >> GO TO 2.
- NO >> GO TO 4.

2. CHECK AIR MIX DOOR MOTOR (PASSENGER SIDE) GROUND CIRCUIT

1. Turn ignition switch OFF.
2. Disconnect air mix door motor (passenger side) connector.
3. Check continuity between air mix door motor (passenger side) harness connector and ground.

Air mix door motor (passenger side)		—	Continuity
Connector	Terminal		
M131	3	Ground	Yes

Is the inspection result normal?

- YES >> GO TO 3.
- NO >> Repair harness or connector.

3. CHECK INSTALLATION OF AIR MIX DOOR MOTOR (PASSENGER SIDE)

Check air mix door motor (passenger side) is properly installed. Refer to [HAC-168, "Exploded View"](#).

Is the inspection result normal?

- YES >> Replace air mix door motor (passenger side). Refer to [HAC-170, "AIR MIX DOOR MOTOR : Removal and Installation - Air Mix Door Motor \(Passenger Side\)"](#).
- NO >> Repair or replace malfunctioning part.

4. CHECK AIR MIX DOOR MOTOR (PASSENGER SIDE) POWER SUPPLY CIRCUIT

1. Turn ignition switch OFF.
2. Disconnect air mix door motor (passenger side) connector and A/C auto amp. connector.
3. Check continuity between air mix door motor (passenger side) harness connector and A/C auto amp. harness connector.

Air mix door motor (passenger side)		A/C auto amp.		Continuity
Connector	Terminal	Connector	Terminal	
M131	1	M50	17	Yes

Is the inspection result normal?

- YES >> Replace A/C auto amp. Refer to [HAC-161, "Removal and Installation"](#).
- NO >> Repair harness or connector.

AIR MIX DOOR MOTOR (REAR)

AIR MIX DOOR MOTOR (REAR) : Diagnosis Procedure

INFOID:000000011136171

Regarding Wiring Diagram information, refer to [HAC-51, "Wiring Diagram"](#).

1. CHECK AIR MIX DOOR MOTOR (REAR) POWER SUPPLY

1. Turn ignition switch ON.
2. Check voltage between air mix door motor (rear) harness connector and ground.

POWER SUPPLY AND GROUND CIRCUIT

< DTC/CIRCUIT DIAGNOSIS >

[AUTOMATIC AIR CONDITIONING]

+		-	Voltage (Approx.)
Connector	Terminal		
M132	1	Ground	Battery voltage

Is the inspection result normal?

YES >> GO TO 2.

NO >> GO TO 4.

2. CHECK AIR MIX DOOR MOTOR (REAR) GROUND CIRCUIT

1. Turn ignition switch OFF.
2. Disconnect air mix door motor (rear) connector.
3. Check continuity between air mix door motor (rear) harness connector and ground.

Air mix door motor (rear)		—	Continuity
Connector	Terminal		
M132	3	Ground	Yes

Is the inspection result normal?

YES >> GO TO 3.

NO >> Repair harness or connector.

3. CHECK INSTALLATION OF AIR MIX DOOR MOTOR (REAR)

Check air mix door motor (rear) is properly installed. Refer to [HAC-168, "Exploded View"](#)

Is the inspection result normal?

YES >> Replace air mix door motor (rear). Refer to [HAC-170, "AIR MIX DOOR MOTOR : Removal and Installation - Air Mix Door Motor \(Rear\)"](#).

NO >> Repair or replace malfunctioning part.

4. CHECK AIR MIX DOOR MOTOR (REAR) POWER SUPPLY CIRCUIT

1. Turn ignition switch OFF.
2. Disconnect air mix door motor (rear) connector and A/C auto amp. connector.
3. Check continuity between air mix door motor (rear) harness connector and A/C auto amp. harness connector.

Air mix door motor (rear)		A/C auto amp.		Continuity
Connector	Terminal	Connector	Terminal	
M132	1	M50	17	Yes

Is the inspection result normal?

YES >> Replace A/C auto amp. Refer to [HAC-161, "Removal and Installation"](#).

NO >> Repair harness or connector.

MODE DOOR MOTOR (FRONT)

MODE DOOR MOTOR (FRONT) : Diagnosis Procedure

INFOID:000000011136172

Regarding Wiring Diagram information, refer to [HAC-51, "Wiring Diagram"](#).

1. CHECK MODE DOOR MOTOR (FRONT) POWER SUPPLY

1. Turn ignition switch ON.
2. Check voltage between mode door motor (front) harness connector and ground.

POWER SUPPLY AND GROUND CIRCUIT

< DTC/CIRCUIT DIAGNOSIS >

[AUTOMATIC AIR CONDITIONING]

+		-	Voltage (Approx.)
Mode door motor (front)			
Connector	Terminal		
M129	1	Ground	Battery voltage

Is the inspection result normal?

- YES >> GO TO 2.
- NO >> GO TO 4.

2. CHECK MODE DOOR MOTOR (FRONT) GROUND CIRCUIT

1. Turn ignition switch OFF.
2. Disconnect mode door motor (front) connector.
3. Check continuity between mode door motor (front) harness connector and ground.

Mode door motor (front)		—	Continuity
Connector	Terminal		
M129	3	Ground	Yes

Is the inspection result normal?

- YES >> GO TO 3.
- NO >> Repair harness or connector.

3. CHECK INSTALLATION OF MODE DOOR MOTOR (FRONT) CONTROL LINKAGE

Check mode door motor (front) control linkage is properly installed. Refer to [HAC-168, "Exploded View"](#).

Is the inspection result normal?

- YES >> Replace mode door motor (front). Refer to [HAC-169, "MODE DOOR MOTOR : Removal and Installation - Mode Door Motor \(Front\)"](#).
- NO >> Repair or replace malfunctioning part.

4. CHECK MODE DOOR MOTOR (FRONT) POWER SUPPLY CIRCUIT

1. Turn ignition switch OFF.
2. Disconnect mode door motor (front) connector and A/C auto amp. connector.
3. Check continuity between mode door motor (front) harness connector and A/C auto amp. harness connector.

Mode door motor (front)		A/C auto amp.		Continuity
Connector	Terminal	Connector	Terminal	
M129	1	M50	17	Yes

Is the inspection result normal?

- YES >> Replace A/C auto amp. Refer to [HAC-161, "Removal and Installation"](#).
- NO >> Repair harness or connector.

MODE DOOR MOTOR (REAR)

MODE DOOR MOTOR (REAR) : Diagnosis Procedure

INFOID:000000011136173

Regarding Wiring Diagram information, refer to [HAC-51, "Wiring Diagram"](#).

1. CHECK MODE DOOR MOTOR (REAR) POWER SUPPLY

1. Turn ignition switch ON.
2. Check voltage between mode door motor (rear) harness connector and ground.

POWER SUPPLY AND GROUND CIRCUIT

< DTC/CIRCUIT DIAGNOSIS >

[AUTOMATIC AIR CONDITIONING]

+		-	Voltage (Approx.)
Mode door motor (rear)			
Connector	Terminal		
M13	1	Ground	Battery voltage

Is the inspection result normal?

- YES >> GO TO 2.
- NO >> GO TO 4.

2. CHECK MODE DOOR MOTOR (REAR) GROUND CIRCUIT

1. Turn ignition switch OFF.
2. Disconnect mode door motor (rear) connector.
3. Check continuity between mode door motor (rear) harness connector and ground.

Mode door motor (rear)		—	Continuity
Connector	Terminal		
M13	3	Ground	Yes

Is the inspection result normal?

- YES >> GO TO 3.
- NO >> Repair harness or connector.

3. CHECK INSTALLATION OF MODE DOOR MOTOR (REAR)

Check mode door motor (rear) is properly installed. Refer to [HAC-168, "Exploded View"](#).

Is the inspection result normal?

- YES >> Replace mode door motor (rear). Refer to [HAC-169, "MODE DOOR MOTOR : Removal and Installation - Mode Door Motor \(Rear\)"](#).
- NO >> Repair or replace malfunctioning part.

4. CHECK MODE DOOR MOTOR (REAR) POWER SUPPLY CIRCUIT

1. Turn ignition switch OFF.
2. Disconnect mode door motor (rear) connector and A/C auto amp. connector.
3. Check continuity between mode door motor (rear) harness connector and A/C auto amp. harness connector.

Mode door motor (rear)		A/C auto amp.		Continuity
Connector	Terminal	Connector	Terminal	
M13	1	M50	17	Yes

Is the inspection result normal?

- YES >> Replace A/C auto amp. Refer to [HAC-161, "Removal and Installation"](#).
- NO >> Repair harness or connector.

INTAKE DOOR MOTOR

INTAKE DOOR MOTOR : Diagnosis Procedure

INFOID:000000011136174

Regarding Wiring Diagram information, refer to [HAC-51, "Wiring Diagram"](#).

1. CHECK INTAKE MODE DOOR MOTOR POWER SUPPLY

1. Turn ignition switch ON.
2. Check voltage between intake mode door motor harness connector and ground.

POWER SUPPLY AND GROUND CIRCUIT

< DTC/CIRCUIT DIAGNOSIS >

[AUTOMATIC AIR CONDITIONING]

+		-	Voltage (Approx.)
Intake mode door motor Connector	Terminal		
M128	1	Ground	Battery voltage

Is the inspection result normal?

- YES >> GO TO 2.
- NO >> GO TO 4.

2. CHECK INTAKE MODE DOOR MOTOR GROUND CIRCUIT

1. Turn ignition switch OFF.
2. Disconnect intake mode door motor connector.
3. Check continuity between intake mode door motor harness connector and ground.

Intake mode door motor		—	Continuity
Connector	Terminal		
M128	3	Ground	Yes

Is the inspection result normal?

- YES >> GO TO 3.
- NO >> Repair harness or connector.

3. CHECK INSTALLATION OF INTAKE MODE DOOR MOTOR

Check intake mode door motor is properly installed. Refer to [HAC-168, "Exploded View"](#).

Is the inspection result normal?

- YES >> Replace intake mode door motor. Refer to [HAC-170, "INTAKE DOOR MOTOR : Removal and Installation"](#).
- NO >> Repair or replace malfunctioning part.

4. CHECK INTAKE MODE DOOR MOTOR POWER SUPPLY CIRCUIT

1. Turn ignition switch OFF.
2. Disconnect intake mode door motor connector and A/C auto amp. connector.
3. Check continuity between intake mode door motor harness connector and A/C auto amp. harness connector.

Intake mode door motor		A/C auto amp.		Continuity
Connector	Terminal	Connector	Terminal	
M128	1	M50	17	Yes

Is the inspection result normal?

- YES >> Replace A/C auto amp. Refer to [HAC-161, "Removal and Installation"](#).
- NO >> Repair harness or connector.

REAR SHUT-OFF DOOR MOTOR

REAR SHUT-OFF DOOR MOTOR : Diagnosis Procedure

INFOID:000000011136175

Regarding Wiring Diagram information, refer to [HAC-51, "Wiring Diagram"](#).

1. CHECK SHUT-OFF DOOR MOTOR POWER SUPPLY

1. Turn ignition switch ON.
2. Check voltage between shut-off door motor harness connector and ground.

POWER SUPPLY AND GROUND CIRCUIT

< DTC/CIRCUIT DIAGNOSIS >

[AUTOMATIC AIR CONDITIONING]

+		-	Voltage (Approx.)
Shut-off door motor			
Connector	Terminal		
M12	1	Ground	Battery voltage

Is the inspection result normal?

- YES >> GO TO 2.
- NO >> GO TO 4.

2.CHECK SHUT-OFF DOOR MOTOR GROUND CIRCUIT

1. Turn ignition switch OFF.
2. Disconnect shut-off door motor connector.
3. Check continuity between shut-off door motor harness connector and ground.

Shut-off door motor		—	Continuity
Connector	Terminal		
M12	3	Ground	Yes

Is the inspection result normal?

- YES >> GO TO 3.
- NO >> Repair harness or connector.

3.CHECK INSTALLATION OF SHUT-OFF DOOR MOTOR

Check shut-off door motor is properly installed. Refer to [HAC-168, "Exploded View"](#).

Is the inspection result normal?

- YES >> Replace shut-off door motor. Refer to [HAC-170, "REAR SHUT-OFF DOOR MOTOR : Removal and Installation"](#).
- NO >> Repair or replace malfunctioning part.

4.CHECK SHUT-OFF DOOR MOTOR POWER SUPPLY CIRCUIT

1. Turn ignition switch OFF.
2. Disconnect shut-off door motor connector and A/C auto amp. connector.
3. Check continuity between shut-off door motor harness connector and A/C auto amp. harness connector.

Shut-off door motor		A/C auto amp.		Continuity
Connector	Terminal	Connector	Terminal	
M12	1	M50	17	Yes

Is the inspection result normal?

- YES >> Replace A/C auto amp. Refer to [HAC-161, "Removal and Installation"](#).
- NO >> Repair harness or connector.

REAR A/C CONTROL

REAR A/C CONTROL : Diagnosis Procedure

INFOID:000000011136176

Regarding Wiring Diagram information, refer to [HAC-51, "Wiring Diagram"](#).

1.CHECK FUSE

Check 10A fuse [No. 30, located in the fuse block (J/B)].

NOTE:

Refer to [PG-84, "Terminal Arrangement"](#).

Is the inspection result normal?

- YES >> GO TO 2.

POWER SUPPLY AND GROUND CIRCUIT

[AUTOMATIC AIR CONDITIONING]

< DTC/CIRCUIT DIAGNOSIS >

NO >> Replace the blown fuse after repairing the affected circuit.

2. CHECK REAR AIR CONTROL POWER SUPPLY

1. Turn ignition switch OFF.
2. Disconnect rear air control connector.
3. Turn ignition switch ON.
4. Check voltage between rear air control harness connector and ground.

+		-	Voltage (Approx.)
Rear air control			
Connector	Terminal		
M258	12	Ground	Battery voltage

Is the inspection result normal?

YES >> GO TO 3.

NO >> Repair harness or connector between rear air control and fuse block (J/B).

3. CHECK REAR AIR CONTROL GROUND CIRCUIT

1. Turn ignition switch OFF.
2. Check continuity between rear air control harness connector and ground.

Rear air control		—	Continuity
Connector	Terminal		
M258	1	Ground	Yes

Is the inspection result normal?

YES >> Replace rear air control. Refer to [HAC-160. "Removal and Installation"](#).

NO >> Repair harness or connector.

DOOR MOTOR

< DTC/CIRCUIT DIAGNOSIS >

[AUTOMATIC AIR CONDITIONING]

DOOR MOTOR

Diagnosis Procedure

INFOID:000000011136177

Regarding Wiring Diagram information, refer to [HAC-51, "Wiring Diagram"](#).

1. CHECK EACH DOOR MOTOR POWER SUPPLY

1. Turn ignition switch ON.
2. Check voltage between intake door motor harness connector and ground.

+		-	Voltage (Approx.)
Intake door motor			
Connector	Terminal		
M128	1	Ground	Battery voltage

Is the inspection result normal?

- YES >> GO TO 2.
NO >> GO TO 3.

2. CHECK EACH DOOR MOTOR GROUND CIRCUIT

1. Turn ignition switch OFF.
2. Disconnect intake door motor connector.
3. Check continuity between intake door motor harness connector and ground.

Intake door motor		—	Continuity
Connector	Terminal		
M128	3	Ground	Yes

Is the inspection result normal?

- YES >> Inspection End.
NO >> Repair harness or connector.

3. CHECK EACH DOOR MOTOR POWER SUPPLY CIRCUIT FOR OPEN

1. Disconnect A/C auto amp. connector.
2. Check continuity between intake door motor harness connector and A/C auto amp. harness connector.

Intake door motor		A/C auto amp.		Continuity
Connector	Terminal	Connector	Terminal	
M128	1	M50	17	Yes

Is the inspection result normal?

- YES >> GO TO 4.
NO >> Repair harness or connector.

4. CHECK EACH DOOR MOTOR POWER SUPPLY CIRCUIT FOR SHORT

1. Disconnect following connectors.
 - Air mix door motor (driver side)
 - Air mix door motor (passenger side)
 - Mode door motor (front)
 - Rear shut-off door motor
 - Air mix door motor (rear)
 - Mode door motor (rear)
2. Check continuity between intake door motor harness connector and ground.

A
B
C
D
E
F
G
H
J
K
L
M
N
O
P

HAC

DOOR MOTOR

< DTC/CIRCUIT DIAGNOSIS >

[AUTOMATIC AIR CONDITIONING]

Intake door motor		—	Continuity
Connector	Terminal		
M128	1	Ground	No

Is the inspection result normal?

YES >> Replace A/C auto amp. Refer to [HAC-161, "Removal and Installation"](#).

NO >> Repair harness or connector.

DOOR MOTOR COMMUNICATION CIRCUIT

< DTC/CIRCUIT DIAGNOSIS >

[AUTOMATIC AIR CONDITIONING]

DOOR MOTOR COMMUNICATION CIRCUIT

Diagnosis Procedure

INFOID:0000000011554109

Regarding Wiring Diagram information, refer to [HAC-51, "Wiring Diagram"](#).

NOTE:

If all of door motor DTCs are detected, check this circuit.

1. CHECK EACH DOOR MOTOR COMMUNICATION SIGNAL

1. Turn ignition switch ON.
2. Check output waveform between A/C auto amp. harness connector and ground with the oscilloscope.

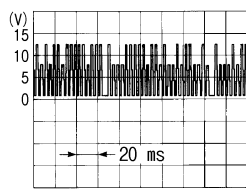
+		-	Output waveform
A/C auto amp.			
Connector	Terminal		
M50	16	Ground	 <p style="text-align: right;">SJIA1453J</p>

Is the inspection result normal?

- YES >> GO TO 2.
NO >> GO TO 3.

2. CHECK EACH DOOR MOTOR COMMUNICATION SIGNAL CIRCUIT FOR OPEN

1. Turn ignition switch OFF.
2. Disconnect A/C auto amp. connector and intake door motor connector.
3. Check continuity between A/C auto amp. harness connector and intake door motor harness connector.

A/C auto amp.		Intake door motor		Continuity
Connector	Terminal	Connector	Terminal	
M50	16	M128	2	Yes

Is the inspection result normal?

- YES >> Inspection End.
NO >> Repair harness or connector.

3. CHECK EACH DOOR MOTOR COMMUNICATION SIGNAL CIRCUIT FOR SHORT

1. Disconnect following connectors.
 - Air mix door motor (driver side)
 - Air mix door motor (passenger side)
 - Mode door motor (front)
 - Rear shut-off door motor
 - Air mix door motor (rear)
 - Mode door motor (rear)
2. Check continuity between A/C auto amp. harness connector and ground.

A/C auto amp.		—	Continuity
Connector	Terminal		
M50	16	Ground	No

A

B

C

D

E

F

G

H

HAC

J

K

L

M

N

O

P

DOOR MOTOR COMMUNICATION CIRCUIT

< DTC/CIRCUIT DIAGNOSIS >

[AUTOMATIC AIR CONDITIONING]

Is the inspection result normal?

YES >> Replace A/C auto amp. Refer to [HAC-161, "Removal and Installation"](#).

NO >> Repair harness or connector.

FRONT BLOWER MOTOR

< DTC/CIRCUIT DIAGNOSIS >

[AUTOMATIC AIR CONDITIONING]

FRONT BLOWER MOTOR

Diagnosis Procedure

INFOID:0000000011554290

Regarding Wiring Diagram information, refer to [HAC-51, "Wiring Diagram"](#).

1. CHECK FUSE

1. Turn ignition switch OFF.
2. Check 15A fuses [Nos. 17 and 27, located in fuse block (J/B)].

NOTE:

Refer to [PG-84, "Terminal Arrangement"](#).

Is the inspection result normal?

YES >> GO TO 2.

NO >> Replace the blown fuse after repairing the affected circuit.

2. CHECK FRONT BLOWER MOTOR POWER SUPPLY

1. Disconnect front blower motor connector.
2. Turn ignition switch ON.
3. Check voltage between front blower motor harness connector and ground.

+		-	Voltage
Front blower motor			
Connector	Terminal		
M112	4	Ground	Battery voltage

Is the inspection result normal?

YES >> GO TO 3.

NO >> GO TO 6.

3. CHECK FRONT BLOWER MOTOR GROUND CIRCUIT

1. Turn ignition switch OFF.
2. Check continuity between front blower motor harness connector and ground.

Front blower motor		—	Continuity
Connector	Terminal		
M112	1	Ground	Yes

Is the inspection result normal?

YES >> GO TO 4.

NO >> Repair harness or connector.

4. CHECK FRONT BLOWER MOTOR CONTROL SIGNAL CIRCUIT

1. Disconnect A/C auto amp. connector.
2. Check continuity between front blower motor harness connector and A/C auto amp. harness connector.

Front blower motor		A/C auto amp.		Continuity
Connector	Terminal	Connector	Terminal	
M112	3	M50	18	Yes

Is the inspection result normal?

YES >> GO TO 5.

NO >> Repair the harness or connector.

5. CHECK FRONT BLOWER MOTOR CONTROL SIGNAL

A

B

C

D

E

F

G

H

HAC

J

K

L

M

N

O

P

FRONT BLOWER MOTOR

[AUTOMATIC AIR CONDITIONING]

< DTC/CIRCUIT DIAGNOSIS >

1. Reconnect front blower motor connector and A/C auto amp. connector.
2. Turn ignition switch ON.
3. Operate MODE switch to set air outlet to VENT.
4. Change fan speed from Lo to Hi, and check duty ratios between front blower motor harness connector and ground by using an oscilloscope.

NOTE:

Calculate drive signal duty ratio as shown in the figure.
T2 = Approx. 1.6 ms

Front blower motor		Condition	Duty ratio (Approx.)
Connector	Terminal	Fan speed (manual) VENT mode	
M112	3	1st	25 %
		2nd	33 %
		3rd	41 %
		4th	51 %
		5th	61 %
		6th	69 %
		7th	81 %

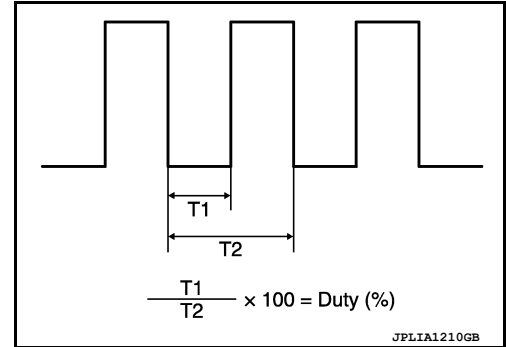

Is the inspection result normal?

YES >> Replace front blower motor. Refer to [VTL-20, "FRONT BLOWER MOTOR : Removal and Installation"](#).

NO >> Replace A/C auto amp. Refer to [HAC-161, "Removal and Installation"](#).

6. CHECK FRONT BLOWER MOTOR RELAY GROUND CIRCUIT

1. Turn ignition switch OFF.
2. Check continuity between fuse block (J/B) harness connector and ground.

Fuse block (J/B)		—	Continuity
Connector	Terminal		
M68	13R	Ground	Yes

Is the inspection result normal?

YES >> GO TO 7.

NO >> Repair harness or connector.

7. CHECK FRONT BLOWER RELAY

Check front blower motor relay. Refer to [HAC-134, "Component Inspection \(Front Blower Motor Relay\)"](#).

Is the inspection result normal?

YES >> Repair harness or connector between front blower motor and fuse block (J/B).

NO >> Replace front blower relay.

Component Inspection (Front Blower Motor)

INFOID:000000011136180

1. CHECK FRONT BLOWER MOTOR

1. Connect battery voltage to terminal 1 of front blower motor.
2. Connect ground to terminal 2 of front blower motor.

Does the front blower fan operate?

YES >> Intermittent incident. Refer to [GI-50, "Intermittent Incident"](#).

NO >> Replace front blower motor. Refer to [VTL-20, "FRONT BLOWER MOTOR : Removal and Installation"](#).

Component Inspection (Front Blower Motor Relay)

INFOID:000000011136181

1. CHECK BLOWER RELAY

FRONT BLOWER MOTOR

[AUTOMATIC AIR CONDITIONING]

< DTC/CIRCUIT DIAGNOSIS >

1. Turn ignition switch OFF.
2. Remove front blower motor relay.
3. Check continuity between front blower motor relay terminals 3 and 5 when voltage is supplied between terminals 1 and 2.

Terminals		Voltage	Continuity
3	5	ON	Yes
		OFF	No

Is the inspection result normal?

- YES >> Inspection End.
NO >> Replace front blower motor relay.

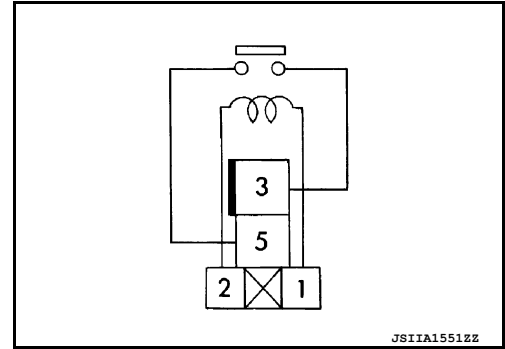

A
B
C
D
E
F
G
H
J
K
L
M
N
O
P

HAC

IONIZER

Component Function Check

INFOID:000000011136182

1. CHECK IONIZER OPERATION SOUND

1. Turn ignition switch ON.
2. Check ionizer operation sound (whirring sound) in duct by putting an ear to the side ventilator grille (driver side) outlet while pressing fan switch and OFF switch alternately.

Is the inspection result normal?

- YES >> Inspection End.
 NO >> Refer to [HAC-136. "Diagnosis Procedure"](#).

Diagnosis Procedure

INFOID:000000011136183

Regarding Wiring Diagram information, refer to [HAC-51. "Wiring Diagram"](#).

1. CHECK FUSE

1. Turn ignition switch OFF.
2. Check 10A fuse [No.30, located in fuse block (J/B)].

NOTE:

Refer to [PG-84. "Terminal Arrangement"](#).

Is the inspection result normal?

- YES >> GO TO 2.
 NO >> Replace the blown fuse after repairing the affected circuit.

2. CHECK IONIZER POWER SUPPLY

1. Disconnect ionizer connector.
2. Turn ignition switch ON.
3. Check voltage between ionizer harness connector and ground.

+		-	Voltage (Approx.)
Ionizer			
Connector	Terminal		
M119	1	Ground	Battery voltage

Is the inspection result normal?

- YES >> GO TO 3.
 NO >> Repair harness or connector between ionizer and fuse block (J/B).

3. CHECK IONIZER GROUND CIRCUIT

1. Turn ignition switch OFF.
2. Check continuity between ionizer harness connector and ground.

Ionizer		—	Continuity
Connector	Terminal		
M119	3	Ground	Yes

Is the inspection result normal?

- YES >> GO TO 4.
 NO >> Repair harness or connector.

4. CHECK IONIZER (ON/OFF) CONTROL SIGNAL CIRCUIT

1. Connect ionizer connector.
2. Disconnect A/C auto amp. connector.

IONIZER

[AUTOMATIC AIR CONDITIONING]

< DTC/CIRCUIT DIAGNOSIS >

3. Turn ignition switch ON.
4. Check voltage between A/C auto amp. harness connector and ground.

+		-	Voltage (Approx.)
A/C auto amp.			
Connector	Terminal		
M50	38	Ground	Battery voltage

Is the inspection result normal?

- YES >> Replace A/C auto amp. Refer to [HAC-161. "Removal and Installation"](#).
NO >> GO TO 5.

5. CHECK IONIZER (ON/OFF) CONTROL SIGNAL CIRCUIT FOR OPEN

1. Turn ignition switch OFF.
2. Disconnect ionizer connector.
3. Check continuity between A/C auto amp. harness connector and ionizer harness connector.

A/C auto amp.		Ionizer		Continuity
Connector	Terminal	Connector	Terminal	
M50	38	M119	4	Yes

Is the inspection result normal?

- YES >> GO TO 6.
NO >> Repair harness or connector.

6. CHECK IONIZER (ON/OFF) CONTROL SIGNAL CIRCUIT FOR SHORT

Check continuity between A/C auto amp. harness connector and ground.

A/C auto amp.		—	Continuity
Connector	Terminal		
M50	38	Ground	No

Is the inspection result normal?

- YES >> Replace ionizer. Refer to [HAC-172. "Removal and Installation"](#).
NO >> Repair harness or connector.

A
B
C
D
E
F
G
H
J
K
L
M
N
O
P

HAC

MAGNET CLUTCH

< DTC/CIRCUIT DIAGNOSIS >

[AUTOMATIC AIR CONDITIONING]

MAGNET CLUTCH

Component Function Check

INFOID:0000000011136184

1.CHECK MAGNET CLUTCH OPERATION

Perform auto active test of IPDM E/R. Refer to [PCS-8, "Diagnosis Description"](#).

Does it operate normally?

YES >> Inspection End.

NO >> Refer to [HAC-138, "Diagnosis Procedure"](#).

Diagnosis Procedure

INFOID:0000000011136185

Regarding Wiring Diagram information, refer to [HAC-51, "Wiring Diagram"](#).

1.CHECK FUSE

1. Turn ignition switch OFF.
2. Check 10A fuse (No. 53, located in IPDM E/R).

NOTE:

Refer to [PG-85, "Terminal Arrangement"](#).

Is the inspection result normal?

YES >> GO TO 2.

NO >> Replace the blown fuse after repairing the affected circuit.

2.CHECK MAGNET CLUTCH POWER SUPPLY CIRCUIT

1. Disconnect compressor connector and IPDM E/R connector.
2. Check continuity between compressor harness connector and IPDM E/R harness connector.

Compressor		IPDM E/R		Continuity
Connector	Terminal	Connector	Terminal	
F3	1	F19	56	Yes

Is the inspection result normal?

YES >> GO TO 3.

NO >> Repair harness or connector.

3.CHECK MAGNET CLUTCH GROUND CIRCUIT

1. Disconnect compressor connector.
2. Check continuity between compressor harness connector and ground.

Compressor		—	Continuity
Connector	Terminal		
F3	2	Ground	Yes

Is the inspection result normal?

YES >> GO TO 4.

NO >> Repair harness or connector.

4.CHECK MAGNET CLUTCH

Directly apply battery voltage to the magnet clutch. Check operation visually and by sound.

Does it operate normally?

YES >> Replace IPDM E/R. Refer to [PCS-32, "Removal and Installation"](#).

NO >> Replace magnet clutch. Refer to [HA-31, "MAGNET CLUTCH : Removal and Installation of Compressor Clutch"](#).

PTC HEATER RELAY

< DTC/CIRCUIT DIAGNOSIS >

[AUTOMATIC AIR CONDITIONING]

PTC HEATER RELAY

Description

INFOID:0000000011136186

Power is supplied to the PTC heater with A/C auto amp. control.

Component Function Check

INFOID:0000000011136187

1. CHECK PTC HEATER RELAY POWER SUPPLY CIRCUIT

Check that an operation noise of PTC heater relay (located in relay box) can be heard when operating the rear air conditioning system in heat mode.

Is the inspection result normal?

- YES >> PTC heater relay power supply circuit is OK.
- NO >> Refer to [HAC-139, "Diagnosis Procedure"](#).

Diagnosis Procedure

INFOID:0000000011136188

Regarding Wiring Diagram information, refer to [HAC-51, "Wiring Diagram"](#).

1. CHECK PTC HEATER RELAY GROUND CIRCUIT

1. Turn ignition switch ON.
2. Check voltage between A/C auto amp. connector and ground.

Terminals		Voltage (V) (Approx.)	
(+)	(-)		
A/C auto amp.	Terminal	Ground	Battery voltage
M50	19		
	39		

Is the inspection result normal?

- YES >> GO TO 2.
- NO >> Replace A/C auto amp. Refer to [HAC-161, "Removal and Installation"](#).

2. CHECK HARNESS CONTINUITY

1. Turn ignition switch OFF.
2. Disconnect A/C auto amp. and PTC heater relay connector.
3. Check continuity between A/C auto amp. connector and PTC heater relay connector.

A/C auto amp. connector	Terminal	PTC heater relay connector	Terminal	Continuity
M50	19	E11	2	Yes
	39	E12		

4. Check continuity between A/C auto amp. connector and ground.

A/C auto amp. connector	Terminal	Ground	Continuity
M50	19	Ground	No
	39		

Is the inspection result normal?

- YES >> GO TO 3.
- NO >> Repair or replace harness.

3. CHECK PTC HEATER RELAY

A
B
C
D
E
F
G
H
J
K
L
M
N
O
P

HAC

PTC HEATER RELAY

[AUTOMATIC AIR CONDITIONING]

< DTC/CIRCUIT DIAGNOSIS >

Check PTC heater relay. Refer to [HAC-140. "Component Inspection"](#).

Is the inspection result normal?

- YES >> Check intermittent incident. Refer to [GI-50. "Intermittent Incident"](#).
- NO >> Replace PTC heater relay.

Component Inspection

INFOID:000000011136189

1. CHECK PTC HEATER RELAY

1. Turn ignition switch OFF.
2. Remove PTC heater relay.
3. Check continuity between PTC heater relay terminal 3 and 5 when voltage is supplied between terminal 1 and 2.

Terminal		Voltage	Continuity
3	5	ON	Yes
		OFF	No

Is the inspection result normal?

- YES >> Inspection End.
- NO >> Replace PTC heater relay.

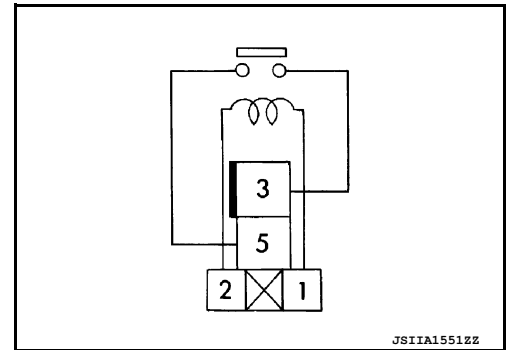

PTC HEATER

Diagnosis Procedure

INFOID:000000011136190

Regarding Wiring Diagram information, refer to [HAC-51, "Wiring Diagram"](#).

1. CHECK FUSE

1. Turn ignition switch OFF.
2. Check 30A fuse [No. 59 and 60, located in relay box].

NOTE:

Refer to [PG-84, "Terminal Arrangement"](#).

Is the inspection result normal?

YES >> GO TO 2.

NO >> Replace the blown fuse after repairing the affected circuit.

2. CHECK POWER SUPPLY CIRCUIT

1. Turn ignition switch ON.
2. Check voltage between PTC heater connector and ground.

Terminals		Condition of PTC heater	Voltage (V) (Approx.)
(+)			
PTC heater connector	Terminal	(-)	
M118	1	ON	Battery voltage
		OFF	0
	3	ON	Battery voltage
		OFF	0

Is the inspection result normal?

YES >> GO TO 3.

NO >> GO TO 4.

3. CHECK GROUND CIRCUIT

1. Turn ignition switch OFF.
2. Disconnect PTC heater connector.
3. Check continuity between PTC heater connector and ground.

PTC heater connector	Terminal	Ground	Continuity
M117	2		
	4		

Is the inspection result normal?

YES >> Replace PTC heater. Refer to [HA-49, "Removal and Installation"](#).

NO >> Repair or replace harness.

4. CHECK HARNESS CONTINUITY

1. Disconnect PTC relay connectors.
2. Check continuity between PTC heater connector and PTC relay connector.

PTC heater connector	Terminal	PTC heater relay connector	Terminal	Continuity

A
B
C
D
E
F
G
H
HAC
J
K
L
M
N
O
P

PTC HEATER

< DTC/CIRCUIT DIAGNOSIS >

[AUTOMATIC AIR CONDITIONING]

M118	1	E11	5	Yes
	3	E12		

3. Check continuity between PTC heater connector and ground.

PTC heater connector	Terminal	Ground	Continuity
M118	1		Ground
	3		

Is the inspection result normal?

YES >> Check intermittent incident. Refer to [GI-50, "Intermittent Incident"](#).

NO >> Replace or repair harness.

REAR BLOWER MOTOR

< DTC/CIRCUIT DIAGNOSIS >

[AUTOMATIC AIR CONDITIONING]

REAR BLOWER MOTOR

Diagnosis Procedure

INFOID:000000011136191

Regarding Wiring Diagram information, refer to [HAC-51, "Wiring Diagram"](#).

REAR BLOWER MOTOR 1

1. CHECK FUSE

Check 20A fuse [No. 70, located in the fuse block (J/B)].

Is the inspection result normal?

YES >> GO TO 2.

NO >> Replace the blown fuse after repairing the affected circuit.

2. CHECK POWER SUPPLY FOR REAR BLOWER MOTOR 1

1. Turn ignition switch ON.
2. Check voltage between rear blower motor 1 harness connector and ground.

(+)		(-)	Voltage (Approx.)
Rear blower motor 1			
Connector	Terminal	Ground	Battery voltage
M107	1		

Is the inspection result normal?

YES >> GO TO 3.

NO >> GO TO 7.

3. CHECK POWER SUPPLY FOR REAR BLOWER MOTOR RESISTOR 1

Check voltage between rear blower motor resistor 1 harness connector and ground.

(+)		(-)	Voltage (Approx.)
Rear blower motor resistor 1			
Connector	Terminal	Ground	Battery voltage
M104	1		

Is the inspection result normal?

YES >> GO TO 4.

NO >> GO TO 8.

4. CHECK BLOWER MOTOR CONTROL SIGNAL

1. Turn mode control to VENT.
2. Turn fan control to 1st speed.
3. Check voltage between rear blower motor resistor 1 harness connector and ground.

(+)		(-)	Voltage (Approx.)
Rear blower motor resistor 1			
Connector	Terminal	Ground	2.5 V
M104	2		

Is the inspection result normal?

YES >> GO TO 5.

NO-1 >> Less than approximately 2.5 V: GO TO 9.

NO-2 >> More than approximately 10 V: Replace auto amp.

5. CHECK REAR BLOWER MOTOR RESISTOR 1 GROUND CIRCUIT

1. Disconnect rear blower motor resistor 1 connector.

A
B
C
D
E
F
G
H
J
K
L
M
N
O
P

HAC

REAR BLOWER MOTOR

< DTC/CIRCUIT DIAGNOSIS >

[AUTOMATIC AIR CONDITIONING]

2. Check continuity between rear blower motor resistor 1 harness connector and ground.

Rear blower motor resistor 1		—	Continuity
Connector	Terminal		
M104	3	Ground	Yes

Is the inspection result normal?

YES >> GO TO 6.

NO >> Repair harness or connector.

6. CHECK BLOWER MOTOR FEEDBACK SIGNAL

1. Reconnect rear blower motor resistor 1 connector.
2. Turn ignition switch ON.
3. Turn fan control to 1st speed.
4. Check voltage between auto amp. harness connector and ground.

(+)		(-)	Condition	Voltage (Approx.)
Auto amp.				
Connector	Terminal			
M50	34	Ground	Blower speed: 1st (Blower motor operating)	10 V

Is the inspection result normal?

YES >> Replace auto amp.

NO >> Repair harness or connector.

7. CHECK POWER SUPPLY OF REAR BLOWER MOTOR RELAY

1. Turn ignition switch OFF.
2. Remove blower relay.
3. Turn ignition switch ON.
4. Check voltage between rear blower motor relay connector terminals and ground.

(+)		(-)	Voltage (Approx.)
Rear blower motor relay			
Connector	Terminal		
M108	1	Ground	Battery voltage
	3		
	6		

Is the inspection result normal?

YES >> Check rear blower motor relay. Refer to [HAC-147. "Component Inspection \(Rear Blower Motor Relay\)"](#).

NO >> Repair harness or connector.

8. CHECK CIRCUIT CONTINUITY BETWEEN BLOWER MOTOR AND REAR BLOWER MOTOR RESISTOR

1

1. Turn ignition switch OFF.
2. Disconnect rear blower motor resistor 1 connector.
3. Check continuity between rear blower motor 1 harness connector and rear blower motor resistor 1 harness connector.

Rear blower motor 1		Rear blower motor resistor 1		Continuity
Connector	Terminal	Connector	Terminal	
M107	2	M104	1	Yes

Is the inspection result normal?

REAR BLOWER MOTOR

[AUTOMATIC AIR CONDITIONING]

< DTC/CIRCUIT DIAGNOSIS >

- YES >> Replace rear blower motor 1.
NO >> Repair harness or connector.

9. CHECK REAR BLOWER MOTOR RESISTOR 1

Check rear blower motor resistor 1 Refer to [HAC-147. "Component Inspection \(Rear Blower Motor Resistor\)"](#).

Is the inspection result normal?

- YES >> Replace auto amp.
NO >> Replace rear blower motor resistor 1.

REAR BLOWER MOTOR 2

1. CHECK FUSE

Check 20A fuse [No. 71, located in the fuse block (J/B)].

Is the inspection result normal?

- YES >> GO TO 2.
NO >> Replace fuse after repairing the affected circuit.

2. CHECK POWER SUPPLY FOR REAR BLOWER MOTOR 2

1. Turn ignition switch ON.
2. Check voltage between rear blower motor 2 harness connector and ground.

(+)		(-)	Voltage (Approx.)
Rear blower motor 2			
Connector	Terminal		
B134	1	Ground	Battery voltage

Is the inspection result normal?

- YES >> GO TO 3.
NO >> GO TO 7.

3. CHECK POWER SUPPLY FOR REAR BLOWER MOTOR RESISTOR 2

Check voltage between rear blower motor resistor 2 harness connector and ground.

(+)		(-)	Voltage (Approx.)
Rear blower motor resistor 2			
Connector	Terminal		
B133	1	Ground	Battery voltage

Is the inspection result normal?

- YES >> GO TO 4.
NO >> GO TO 8.

4. CHECK BLOWER MOTOR CONTROL SIGNAL

1. Turn mode control to VENT.
2. Turn fan control to 1st speed.
3. Check voltage between rear blower motor resistor 2 harness connector and ground.

(+)		(-)	Voltage (Approx.)
Rear blower motor resistor 2			
Connector	Terminal		
B133	2	Ground	2.5 V

Is the inspection result normal?

- YES >> GO TO 5.
NO-1 >> Less than approximately 2.5 V: GO TO 9.
NO-2 >> More than approximately 10 V: Replace auto amp.

A
B
C
D
E
F
G
H
J
K
L
M
N
O
P

HAC

REAR BLOWER MOTOR

[AUTOMATIC AIR CONDITIONING]

< DTC/CIRCUIT DIAGNOSIS >

5. CHECK REAR BLOWER MOTOR RESISTOR 2 GROUND CIRCUIT

1. Disconnect rear blower motor resistor 2 connector.
2. Check continuity between rear blower motor resistor 2 harness connector and ground.

Rear blower motor resistor 2		—	Continuity
Connector	Terminal		
B133	3	Ground	Yes

Is the inspection result normal?

YES >> GO TO 6.

NO >> Repair harness or connector.

6. CHECK BLOWER MOTOR FEEDBACK SIGNAL

1. Reconnect rear blower motor resistor 2 connector.
2. Turn ignition switch ON.
3. Turn fan control to 1st speed.
4. Check voltage between auto amp. harness connector and ground.

(+) Auto amp.		(-)	Condition	Voltage (Approx.)
Connector	Terminal			
M50	32	Ground	Blower speed: 1st (Blower motor operating)	10 V

Is the inspection result normal?

YES >> Replace auto amp.

NO >> Repair harness or connector.

7. CHECK POWER VOLTAGE OF REAR BLOWER MOTOR RELAY

1. Turn ignition switch OFF.
2. Remove blower relay.
3. Turn ignition switch ON.
4. Check voltage between rear blower motor relay connector terminals and ground.

(+) Rear blower motor relay		(-)	Voltage (Approx.)
Connector	Terminal		
M108	1	Ground	Battery voltage
	3		
	6		

Is the inspection result normal?

YES >> Check rear blower motor relay. Refer to [HAC-147, "Component Inspection \(Rear Blower Motor Relay\)"](#).

NO >> Repair harness or connector.

8. CHECK CIRCUIT CONTINUITY BETWEEN BLOWER MOTOR AND REAR BLOWER MOTOR RESISTOR 2

1. Turn ignition switch OFF.
2. Disconnect rear blower motor resistor 2 connector.
3. Check continuity between rear blower motor 2 harness connector and rear blower motor resistor 2 harness connector.

REAR BLOWER MOTOR

< DTC/CIRCUIT DIAGNOSIS >

[AUTOMATIC AIR CONDITIONING]

Rear blower motor 2		Rear blower motor resistor 2		Continuity
Connector	Terminal	Connector	Terminal	
B134	2	B133	1	Yes

Is the inspection result normal?

- YES >> Replace rear blower motor 2.
- NO >> Repair harness or connector.

9.CHECK REAR BLOWER MOTOR RESISTOR 2

Check rear blower motor resistor 2. Refer to [HAC-147, "Component Inspection \(Rear Blower Motor Resistor\)"](#).

Is the inspection result normal?

- YES >> Replace auto amp.
- NO >> Replace rear blower motor resistor 2.

Component Inspection (Rear Blower Motor)

INFOID:0000000011136192

1.CHECK REAR BLOWER MOTOR

1. Connect battery voltage to terminal 1 of rear blower motor.
2. Connect ground to terminal 2 of rear blower motor.

Does the rear blower fan operate?

- YES >> Intermittent incident. Refer to [GI-50, "Intermittent Incident"](#).
- NO >> Replace rear blower motor. Refer to [VTL-21, "REAR BLOWER MOTOR 1 : Removal and Installation"](#) or [VTL-22, "REAR BLOWER MOTOR 2 : Removal and Installation"](#).

Component Inspection (Rear Blower Motor Relay)

INFOID:0000000011136193

1.CHECK REAR BLOWER RELAY

1. Remove rear blower relay. Refer to [PG-85, "Terminal Arrangement"](#).
2. Check continuity between rear blower relay terminals 3 and 5, then 6 and 7 when voltage is supplied between terminals 1 and 2.

Terminal		Voltage	Continuity
3	5	ON	Yes
		OFF	No
6	7	ON	Yes
		OFF	No

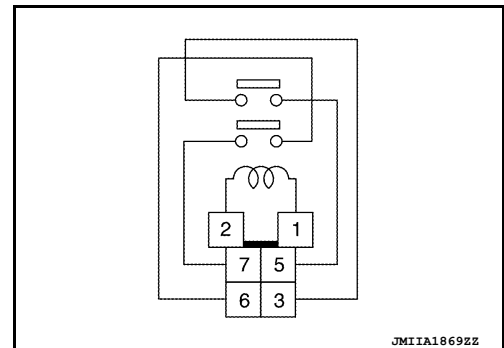

Is the inspection result normal?

- YES >> Inspection End.
- NO >> Replace rear blower relay.

Component Inspection (Rear Blower Motor Resistor)

INFOID:0000000011136194

1.CHECK FAN CONTROL AMP.

1. Turn ignition switch OFF.
2. Remove rear blower motor resistor. Refer to [HAC-171, "Removal and Installation - Rear Blower Motor Resistor 1"](#) or [HAC-171, "Removal and Installation - Rear Blower Motor Resistor 2"](#).
3. Check continuity between the rear blower motor resistor terminals using analog circuit tester.

Terminal		Continuity
(+)	(-)	
3	2	Yes
2	3	No

REAR BLOWER MOTOR

[AUTOMATIC AIR CONDITIONING]

< DTC/CIRCUIT DIAGNOSIS >

Is the inspection result normal?

YES >> Inspection End.

NO >> Replace rear blower motor resistor. Refer to [HAC-171, "Removal and Installation - Rear Blower Motor Resistor 1"](#) or [HAC-171, "Removal and Installation - Rear Blower Motor Resistor 2"](#).

FRONT AUTOMATIC AIR CONDITIONING SYSTEM

< SYMPTOM DIAGNOSIS >

[AUTOMATIC AIR CONDITIONING]

SYMPTOM DIAGNOSIS

FRONT AUTOMATIC AIR CONDITIONING SYSTEM

Diagnosis Chart By Symptom

INFOID:000000011136195

NOTE:

Perform the self-diagnoses with CONSULT before performing the symptom diagnosis. If DTC is detected, perform the corresponding diagnosis.

Symptom	Corresponding malfunction part	Reference
<ul style="list-style-type: none"> Front air conditioning does not activate. Front air conditioning cannot be controlled. Operation status of air conditioning is not indicated on display. 	<ul style="list-style-type: none"> A/C auto amp. ignition power supply circuit Front A/C control (A/C auto amp.) 	HAC-120. "A/C AUTO AMP. : Diagnosis Procedure"
<ul style="list-style-type: none"> Air outlet does not change. Mode door motor (front) does not operate normally. 	<ul style="list-style-type: none"> Circuit between mode door motor (front) and A/C auto amp. Mode door motor (front) control linkage Mode door motor (front) A/C auto amp. 	HAC-123. "MODE DOOR MOTOR (FRONT) : Diagnosis Procedure"
<ul style="list-style-type: none"> Discharge air temperature of driver side does not change. Air mix door motor (driver side) does not operate normally. 	<ul style="list-style-type: none"> Circuit between air mix door motor (driver side) and A/C auto amp. Air mix door motor (driver side) installation condition Air mix door motor (driver side) A/C auto amp. 	HAC-120. "AIR MIX DOOR MOTOR (DRIVER SIDE) : Diagnosis Procedure"
<ul style="list-style-type: none"> Discharge air temperature of passenger side does not change. Air mix door motor (passenger side) does not operate normally. 	<ul style="list-style-type: none"> Circuit between air mix door motor (passenger side) and A/C auto amp. Air mix door motor (passenger side) installation condition Air mix door motor (passenger side) A/C auto amp. 	HAC-121. "AIR MIX DOOR MOTOR (PASSENGER SIDE) : Diagnosis Procedure"
<ul style="list-style-type: none"> Intake door does not change. Intake door motor does not operate normally. 	<ul style="list-style-type: none"> Circuit between intake door motor and A/C auto amp. Intake door motor control linkage Intake door motor A/C auto amp. 	HAC-125. "INTAKE DOOR MOTOR : Diagnosis Procedure"
All door motors do not operate normally.	<ul style="list-style-type: none"> Each door motor power supply and ground circuit A/C auto amp. 	HAC-129. "Diagnosis Procedure"
Front blower motor operation is malfunctioning.	<ul style="list-style-type: none"> Power supply system of front blower motor Circuit between front blower motor and A/C auto amp. Front blower motor A/C auto amp. 	HAC-133. "Diagnosis Procedure"
Compressor does not operate.	<ul style="list-style-type: none"> Circuit between magnet clutch and IPDM E/R Magnet clutch IPDM E/R (A/C relay) Circuit between ECM and refrigerant pressure sensor Refrigerant pressure sensor CAN communication circuit A/C auto amp. 	HAC-138. "Diagnosis Procedure"

A
B
C
D
E
F
G
H
J
K
L
M
N
O
P

HAC

FRONT AUTOMATIC AIR CONDITIONING SYSTEM

< SYMPTOM DIAGNOSIS >

[AUTOMATIC AIR CONDITIONING]

Symptom		Corresponding malfunction part	Reference
<ul style="list-style-type: none"> • Insufficient cooling. • No cool air comes out. (Air flow volume is normal.) 		<ul style="list-style-type: none"> • Magnet clutch control system • Drive belt slipping • Refrigerant cycle • Air leakage from each duct • A/C auto amp. connection recognition signal circuit • Temperature setting trimmer (front) 	HAC-153, "FRONT AIR CONDITIONER : Diagnosis Procedure"
<ul style="list-style-type: none"> • Insufficient heating. • No warm air comes out. (Air flow volume is normal.) 		<ul style="list-style-type: none"> • Engine cooling system • Heater hose • Heater core • Air leakage from each duct • Temperature setting trimmer (front) 	HAC-155, "FRONT AIR CONDITIONER : Diagnosis Procedure"
Noise is heard when front air conditioning system operates.	During compressor operation	Refrigerant cycle	HA-16, "Symptom Table"
	During front blower motor operation	<ul style="list-style-type: none"> • Mixing any foreign object in front blower motor • Front blower motor fan breakage • Front blower motor rotation inferiority 	HAC-134, "Component Inspection (Front Blower Motor)"
<ul style="list-style-type: none"> • Memory function does not operate. • Setting temperature is not memorized. 		<ul style="list-style-type: none"> • Battery power supply system of A/C auto amp. • A/C auto amp. 	HAC-120, "A/C AUTO AMP. : Diagnosis Procedure"

REAR AUTOMATIC AIR CONDITIONING SYSTEM

< SYMPTOM DIAGNOSIS >

[AUTOMATIC AIR CONDITIONING]

REAR AUTOMATIC AIR CONDITIONING SYSTEM

Diagnosis Chart By Symptom

INFOID:000000011136196

NOTE:

- Perform the self-diagnoses with CONSULT before performing the symptom diagnosis. If DTC is detected, perform the corresponding diagnosis.
- The following table is based on the condition that front automatic air conditioning system operates normally.

Symptom	Corresponding malfunction part	Reference
<ul style="list-style-type: none"> • Rear air conditioning cannot be controlled by front A/C control. • Operation status of rear air conditioning is not indicated on front A/C control display. 	A/C auto amp.	Replace A/C auto amp. Refer to HAC-161, "Removal and Installation" .
Rear air conditioning cannot be controlled by rear air control.	Operation status of rear air conditioning is indicated on rear air control display.	Refer to HAC-117, "Diagnosis Procedure" .
	Operation status of rear air conditioning is not indicated on rear air control display.	Refer to HAC-117, "Diagnosis Procedure" .
	Communication signal (rear air control → A/C auto amp.)	Refer to HAC-117, "Diagnosis Procedure" .
	Communication signal (A/C auto amp. → rear air control)	Refer to HAC-117, "Diagnosis Procedure" .
	Rear air control power supply circuit	Refer to HAC-127, "REAR A/C CONTROL : Diagnosis Procedure" .
	<ul style="list-style-type: none"> • Circuit between mode door motor (rear) and A/C auto amp. • Mode door motor (rear) control linkage • Mode door motor (rear) • A/C auto amp. 	HAC-124, "MODE DOOR MOTOR (REAR) : Diagnosis Procedure"
<ul style="list-style-type: none"> • Air outlet does not change. • Mode door motor (rear) does not operate normally. 		
<ul style="list-style-type: none"> • Discharge air temperature does not change. • Air mix door motor (rear) does not operate normally. 	<ul style="list-style-type: none"> • Circuit between air mix door motor (rear) and A/C auto amp. • Air mix door motor (rear) installation condition • Air mix door motor (rear) • A/C auto amp. 	HAC-122, "AIR MIX DOOR MOTOR (REAR) : Diagnosis Procedure"
Rear blower motor operation is malfunctioning.	<ul style="list-style-type: none"> • Power supply system of rear blower motor • Circuit between rear blower motor and A/C auto amp. • Rear blower motor • A/C auto amp. 	HAC-143, "Diagnosis Procedure"
<ul style="list-style-type: none"> • Insufficient cooling. • No cool air comes out. (Air flow volume is normal.) 	<ul style="list-style-type: none"> • A/C auto amp. • Refrigerant cycle • Air leakage from each duct • Temperature setting trimmer (rear) 	HAC-120, "A/C AUTO AMP. : Diagnosis Procedure"
<ul style="list-style-type: none"> • Insufficient heating. • No warm air comes out. (Air flow volume is normal.) 	<ul style="list-style-type: none"> • PTC heater • Air leakage from each duct • Temperature setting trimmer (rear) 	HAC-141, "Diagnosis Procedure"
Noise is heard when rear blower motor operates.	<ul style="list-style-type: none"> • Mixing any foreign object in rear blower motor • Rear blower motor fan breakage • Rear blower motor rotation inferiority 	HAC-147, "Component Inspection (Rear Blower Motor)"

A
B
C
D
E
F
G
H
I
J
K
L
M
N
O
P

HAC

ACCS (ADVANCED CLIMATE CONTROL SYSTEM)

< SYMPTOM DIAGNOSIS >

[AUTOMATIC AIR CONDITIONING]

ACCS (ADVANCED CLIMATE CONTROL SYSTEM)

Symptom Table

INFOID:000000011136197

NOTE:

- Perform the self-diagnoses with CONSULT before performing the symptom diagnosis. If DTC is detected, perform the corresponding diagnosis.
- The following table is based on the condition that front automatic air conditioning system operates normally.

Symptom	Corresponding malfunction part	Reference
Auto intake switch cannot be operated. [Automatic intake control (exhaust gas / outside odor detecting mechanism) does not operate]	A/C and AV switch assembly	Replace the A/C and AV switch assembly. Refer to HAC-159. "Removal and Installation" .
Plasmacluster™ control does not operate.	<ul style="list-style-type: none">• Power supply system of ionizer• The circuit between ionizer and A/C auto amp.• Ionizer• A/C auto amp.	Refer to HAC-136. "Diagnosis Procedure" .
Operation status of Plasmacluster™ control does not switch according to air flow.	A/C auto amp.	Replace A/C auto amp. Refer to HAC-161. "Removal and Installation" .

INSUFFICIENT COOLING

[AUTOMATIC AIR CONDITIONING]

< SYMPTOM DIAGNOSIS >

INSUFFICIENT COOLING FRONT AIR CONDITIONER

FRONT AIR CONDITIONER : Description

INFOID:000000011136198

Symptom

- Insufficient cooling
- No cool air comes out. (Air flow volume is normal.)

FRONT AIR CONDITIONER : Diagnosis Procedure

INFOID:000000011136199

NOTE:

Perform self-diagnoses with CONSULT before performing symptom diagnosis. If any DTC is detected, perform the corresponding diagnosis.

1.CHECK MAGNET CLUTCH OPERATION

1. Turn ignition switch ON.
2. Operate fan switch.
3. Press A/C switch.
4. Check that A/C indicator turns ON. Check visually and by sound that compressor operates.
5. Press A/C switch again.
6. Check that A/C indicator turns OFF. Check that compressor stops.

Is the inspection result normal?

YES >> GO TO 2.

NO >> Perform diagnosis of "COMPRESSOR DOES NOT OPERATE" in "SYMPTOM DIAGNOSIS".
Refer to [HAC-157, "Diagnosis Procedure"](#).

2.CHECK DRIVE BELT

Check tension of drive belt. Refer to [MA-19, "DRIVE BELTS : Checking Drive Belts"](#).

Is the inspection result normal?

YES >> GO TO 3.

NO >> Adjust or replace drive belt depending on the inspection results.

3.CHECK REFRIGERANT CYCLE

Connect recovery/recycling recharging equipment to the vehicle and perform pressure inspection with gauge. Refer to [HA-16, "Symptom Table"](#).

Is the inspection result normal?

YES >> GO TO 4.

NO >> Repair or replace parts depending on the inspection results.

4.CHECK AIR LEAKAGE FROM EACH DUCT

Check duct and nozzle, etc. of the front air conditioning system for leakage.

Is the inspection result normal?

YES >> GO TO 5.

NO >> Repair or replace parts depending on the inspection results.

5.CHECK AMBIENT TEMPERATURE DISPLAY

Check that there is not much difference between actual ambient temperature and indicated temperature on information display in combination meter.

Is the inspection result normal?

YES >> GO TO 6.

NO >> Perform diagnosis for the A/C auto amp. connection recognition signal circuit. Refer to [HAC-91, "Diagnosis Procedure"](#).

6.CHECK SETTING OF TEMPERATURE SETTING TRIMMER (FRONT)

1. Check setting value of temperature setting trimmer (front). Refer to [HAC-82, "FRONT AUTOMATIC AIR CONDITIONING SYSTEM : Temperature Setting Trimmer \(Front\)"](#).
2. Check that temperature setting trimmer (front) is set to "+ direction".

A
B
C
D
E
F
G
H
HAC
J
K
L
M
N
O
P

INSUFFICIENT COOLING

< SYMPTOM DIAGNOSIS >

[AUTOMATIC AIR CONDITIONING]

NOTE:

The control temperature can be set with the setting of the temperature setting trimmer (front).

3. Set difference between set temperature and control temperature to "0".

Is inspection result normal?

YES >> Inspection End.

NO >> Replace A/C auto amp. Refer to [HAC-161. "Removal and Installation"](#).

REAR AIR CONDITIONER

REAR AIR CONDITIONER : Description

INFOID:000000011136200

Symptom

- Insufficient cooling
- No cool air comes out. (Air flow volume is normal.)

REAR AIR CONDITIONER : Diagnosis Procedure

INFOID:000000011136201

NOTE:

Perform self-diagnoses with CONSULT before performing symptom diagnosis. If any DTC is detected, perform the corresponding diagnosis.

1. CHECK REFRIGERANT CYCLE

Connect recovery/recycling recharging equipment to the vehicle and perform pressure inspection with gauge. Refer to [HA-16. "Symptom Table"](#).

Is the inspection result normal?

YES >> GO TO 2.

NO >> Repair or replace parts depending on the inspection results.

2. CHECK AIR LEAKAGE FROM EACH DUCT

Check duct and nozzle, etc. of the rear air conditioning system for leakage.

Is the inspection result normal?

YES >> GO TO 3.

NO >> Repair or replace parts depending on the inspection results.

3. CHECK SETTING OF TEMPERATURE SETTING TRIMMER (REAR)

1. Check setting value of temperature setting trimmer (rear). Refer to [HAC-83. "REAR AUTOMATIC AIR CONDITIONING SYSTEM : Temperature Setting Trimmer \(Rear\)"](#).
2. Check that temperature setting trimmer (rear) is set to "+ direction".

NOTE:

The control temperature can be set with the setting of the temperature setting trimmer (rear).

3. Set difference between set temperature and control temperature to "0".

Is inspection result normal?

YES >> Inspection End.

NO >> Replace A/C auto amp. Refer to [HAC-161. "Removal and Installation"](#).

INSUFFICIENT HEATING

[AUTOMATIC AIR CONDITIONING]

< SYMPTOM DIAGNOSIS >

INSUFFICIENT HEATING FRONT AIR CONDITIONER

FRONT AIR CONDITIONER : Description

INFOID:000000011136202

Symptom

- Insufficient heating
- No warm air comes out. (Air flow volume is normal.)

FRONT AIR CONDITIONER : Diagnosis Procedure

INFOID:000000011136203

NOTE:

Perform self-diagnoses with on board diagnosis and CONSULT before performing symptom diagnosis. If DTC is detected, perform the corresponding diagnosis.

1.CHECK COOLING SYSTEM

1. Check engine coolant level and check leakage. Refer to [CO-10, "System Inspection"](#).
2. Check reservoir tank cap. Refer to [CO-10, "System Inspection"](#).
3. Check water flow sounds of the engine coolant. Refer to [CO-10, "System Inspection"](#).

Is the inspection result normal?

YES >> GO TO 2.

NO >> Refill engine coolant and repair or replace parts depending on the inspection results.

2.CHECK HEATER HOSE

Check installation of heater hose visually or by touching.

Is the inspection result normal?

YES >> GO TO 3.

NO >> Repair or replace parts depending on the inspection results.

3.CHECK HEATER CORE

1. Check temperature of inlet hose and outlet hose of front heater core.
2. Check that inlet side of heater core is hot and the outlet side is slightly lower than/almost equal to the inlet side.

CAUTION:

Always perform the temperature inspection in a short period of time because the engine coolant temperature is very hot.

Is the inspection result normal?

YES >> GO TO 4.

NO >> Replace heater core. Refer to [HA-48, "Removal and Installation"](#).

4.CHECK AIR LEAKAGE FROM EACH DUCT

Check duct and nozzle, etc. of front air conditioning system for air leakage.

Is the inspection result normal?

YES >> GO TO 5.

NO >> Repair or replace parts depending on the inspection results.

5.CHECK SETTING OF TEMPERATURE SETTING TRIMMER (FRONT)

1. Check setting value of temperature setting trimmer (front). Refer to [HAC-82, "FRONT AUTOMATIC AIR CONDITIONING SYSTEM : Temperature Setting Trimmer \(Front\)"](#).
2. Check that temperature setting trimmer (front) is set to "– direction".

NOTE:

The control temperature can be set by the temperature setting trimmer (front).

3. Set difference between the set temperature and control temperature to "0".

Are the symptoms solved?

YES >> Inspection End.

NO >> Replace A/C auto amp. Refer to [HAC-161, "Removal and Installation"](#).

REAR AIR CONDITIONER

A
B
C
D
E
F
G
H
J
K
L
M
N
O
P

HAC

INSUFFICIENT HEATING

< SYMPTOM DIAGNOSIS >

[AUTOMATIC AIR CONDITIONING]

REAR AIR CONDITIONER : Description

INFOID:000000011136204

Symptom

- Insufficient heating
- No warm air comes out. (Air flow volume is normal.)

REAR AIR CONDITIONER : Diagnosis Procedure

INFOID:000000011136205

CAUTION:

Perform the self-diagnoses with on board diagnosis and CONSULT before performing symptom diagnosis. If any malfunction result or DTC is detected, perform the corresponding diagnosis.

1. CHECK PTC HEATER

Check PTC heater. Refer to [HAC-141, "Diagnosis Procedure"](#).

Is the inspection result normal?

YES >> GO TO 2.

NO >> Replace PTC heater. Refer to [HA-49, "Removal and Installation"](#).

2. CHECK AIR LEAKAGE FROM EACH DUCT

Check duct and nozzle, etc. of the rear air conditioning system for air leakage.

Is the inspection result normal?

YES >> GO TO 3.

NO >> Repair or replace parts depending on the inspection results.

3. CHECK SETTING OF TEMPERATURE SETTING TRIMMER (REAR)

1. Check setting value of temperature setting trimmer (rear). Refer to [HAC-83, "REAR AUTOMATIC AIR CONDITIONING SYSTEM : Temperature Setting Trimmer \(Rear\)"](#).

2. Check that the temperature setting trimmer is set to "– direction".

NOTE:

The control temperature can be set by the temperature setting trimmer (rear).

3. Set the difference between the set temperature (rear) and control temperature to "0".

Are the symptoms solved?

YES >> Inspection End.

NO >> Replace A/C auto amp. Refer to [HAC-161, "Removal and Installation"](#).

COMPRESSOR DOES NOT OPERATE

< SYMPTOM DIAGNOSIS >

[AUTOMATIC AIR CONDITIONING]

COMPRESSOR DOES NOT OPERATE

Description

INFOID:0000000011136208

Symptom: Compressor does not operate.

Diagnosis Procedure

INFOID:0000000011136209

NOTE:

- Perform self-diagnoses with CONSULT before performing symptom diagnosis. If DTC is detected, perform the corresponding diagnosis.
- Check that refrigerant system is properly charged. If refrigerant amount is below the proper amount, perform inspection of refrigerant leakage.

1.CHECK MAGNET CLUTCH OPERATION

Check magnet clutch. Refer to [HAC-138, "Component Function Check"](#).

Does it operate normally?

YES >> GO TO 2.

NO >> Repair or replace malfunctioning parts.

2.CHECK REFRIGERANT PRESSURE SENSOR

Check refrigerant pressure sensor. Refer to [EC-527, "Component Function Check"](#) (except for Mexico) or [EC-933, "Component Function Check"](#) (for Mexico).

Is the inspection result normal?

YES >> GO TO 3.

NO >> Repair or replace malfunctioning parts.

3.CHECK A/C AUTO AMP. OUTPUT SIGNAL

ⓂWith CONSULT

Check "COMP REQ SIG" and "FAN REQ SIG" in "DATA MONITOR" mode of "HVAC" using CONSULT.

Monitor item	Condition	Status	
COMP REQ SIG	A/C switch	ON	On
		OFF	Off
FAN REQ SIG	Front blower motor	ON	On
		OFF	Off

Is the inspection result normal?

YES >> GO TO 4.

NO >> Replace A/C auto amp. Refer to [HAC-161, "Removal and Installation"](#).

4.CHECK ECM INPUT SIGNAL

ⓂWith CONSULT

Check "AIR COND SIG" and "HEATER FAN SW" in "DATA MONITOR" mode of "ECM" using CONSULT.

Monitor item	Condition	Status	
AIR COND SIG	A/C switch	ON	On
		OFF	Off
HEATER FAN SW	Front blower motor	ON	On
		OFF	Off

Is the inspection result normal?

YES >> GO TO 5.

NO >> Check CAN communication system. Refer to [LAN-28, "Trouble Diagnosis Flow Chart"](#).

5.CHECK IPDM E/R INPUT SIGNAL

ⓂWith CONSULT

A

B

C

D

E

F

G

H

HAC

J

K

L

M

N

O

P

COMPRESSOR DOES NOT OPERATE

[AUTOMATIC AIR CONDITIONING]

< SYMPTOM DIAGNOSIS >

1. Start engine.
2. Check "AC COMP REQ" in "DATA MONITOR" mode of "IPDM E/R" using CONSULT.

Monitor item	Condition		Status
AC COMP REQ	A/C switch	ON	On
		OFF	Off

Is the inspection result normal?

YES >> Inspection End.

NO >> Check CAN communication system. Refer to [LAN-28, "Trouble Diagnosis Flow Chart"](#).

A/C AND AV SWITCH ASSEMBLY

< REMOVAL AND INSTALLATION >

[AUTOMATIC AIR CONDITIONING]

REMOVAL AND INSTALLATION

A/C AND AV SWITCH ASSEMBLY

Removal and Installation

INFOID:000000011136210

REMOVAL

1. Remove cluster lid C upper. Refer to [JP-23. "CLUSTER LID C UPPER : Removal and Installation"](#).
2. Remove the screws (A) and the A/C and AV switch assembly.

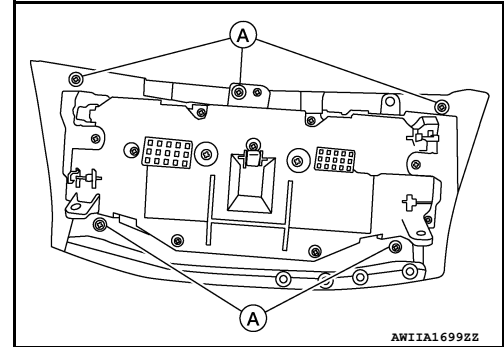

INSTALLATION

Installation is in the reverse order of removal.

A
B
C
D
E
F
G
H
J
K
L
M
N
O
P

HAC

REAR AIR CONTROL

< REMOVAL AND INSTALLATION >

[AUTOMATIC AIR CONDITIONING]

REAR AIR CONTROL

Removal and Installation

INFOID:000000011136211

REMOVAL

1. Remove the rear center ventilation duct. Refer to [VTL-12, "REAR CENTER VENTILATOR DUCT : Removal and Installation"](#).
2. Disconnect the harness connector from the rear air control.
3. Remove the screws and the rear air control.

INSTALLATION

Installation is in the reverse order of removal.

A/C AUTO AMP.

Exploded View

INFOID:000000011136212

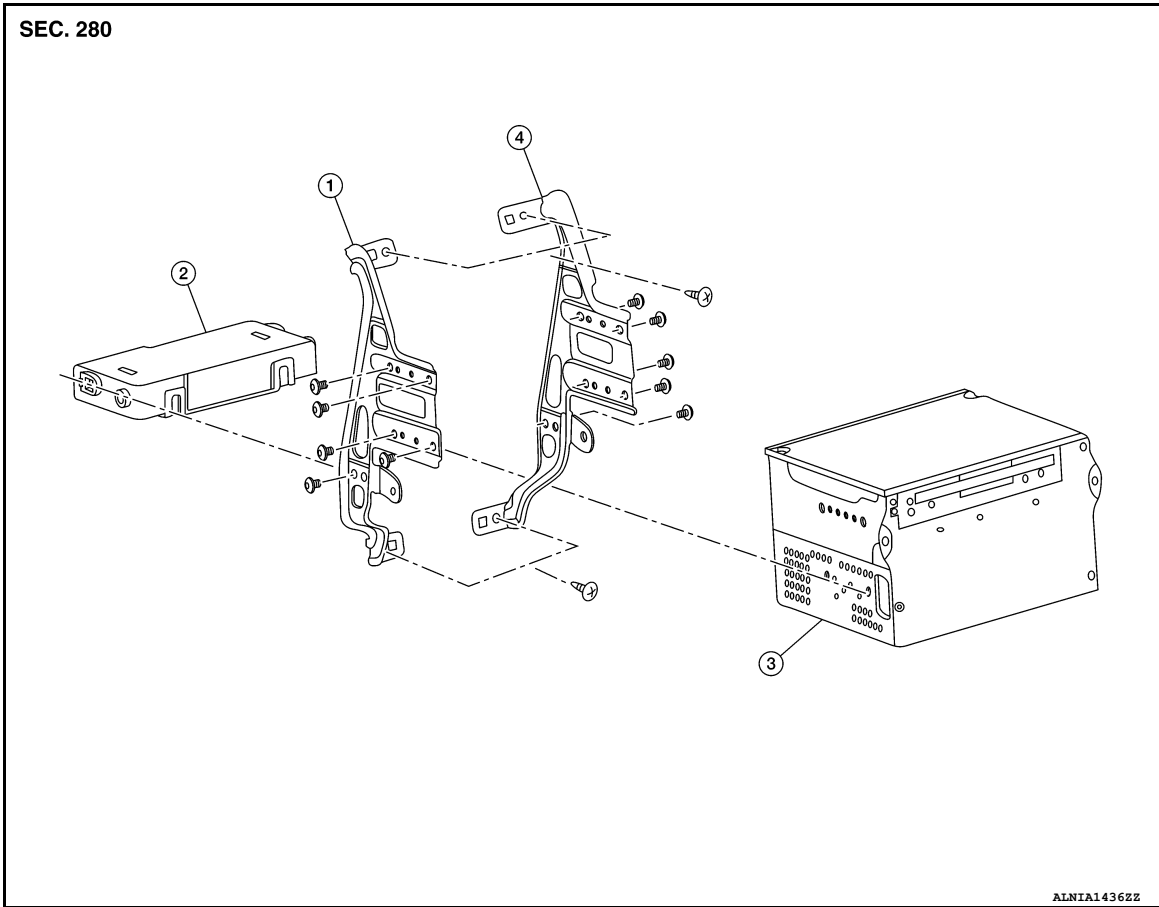

- 1. AV control unit bracket (LH)
- 2. A/C auto amp.
- 3. AV control unit
- 4. AV control unit bracket (RH)

Removal and Installation

INFOID:000000011136213

REMOVAL

1. Remove the AV control unit. Refer to [AV-136. "Removal and Installation - AV Control Unit"](#) (BASE AUDIO), [AV-302. "Removal and Installation - AV Control Unit"](#) (BOSE AUDIO WITHOUT NAVIGATION), [AV-585. "Removal and Installation - AV Control Unit"](#) (BOSE AUDIO W/NAVI W/O SURROUND) or [AV-883. "Removal and Installation - AV Control Unit"](#) (BOSE AUDIO W/NAVI W/SURROUND).
2. Remove the screws and one of the AV control unit brackets (LH or RH).
3. Remove the A/C auto amp.

INSTALLATION

Installation is in the reverse order of removal.

A
B
C
D
E
F
G
H
HAC
J
K
L
M
N
O
P

AMBIENT SENSOR

< REMOVAL AND INSTALLATION >

[AUTOMATIC AIR CONDITIONING]

AMBIENT SENSOR

Removal and Installation

INFOID:000000011136214

REMOVAL

1. Remove the core support cover. Refer to [EXT-16. "Exploded View"](#).
2. Disconnect the harness connector from the ambient sensor.
3. Release the ambient sensor clip, then remove the ambient sensor (1).

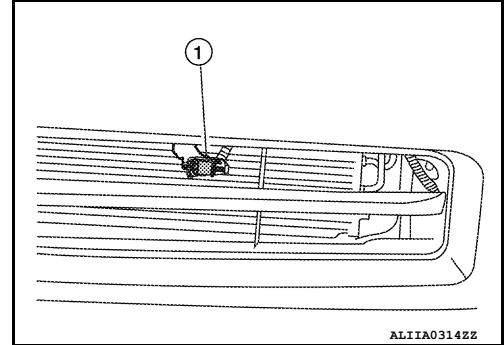

INSTALLATION

Installation is in the reverse order of removal.

IN-VEHICLE SENSOR

< REMOVAL AND INSTALLATION >

[AUTOMATIC AIR CONDITIONING]

IN-VEHICLE SENSOR

Removal and Installation

INFOID:000000011136215

REMOVAL

1. Remove instrument lower panel LH. Refer to [IP-25, "Removal and Installation"](#).
2. Remove the screw (A), and in-vehicle sensor (1).

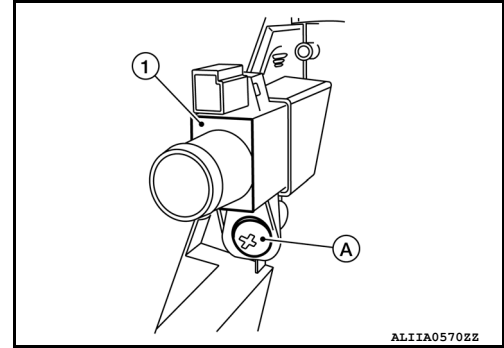

INSTALLATION

Installation is in the reverse order of removal.

CAUTION:

Make sure that the aspirator hose is securely attached to the in-vehicle sensor when installing the instrument lower panel LH.

A
B
C
D
E
F
G
H
J
K
L
M
N
O
P

HAC

SUNLOAD SENSOR

< REMOVAL AND INSTALLATION >

[AUTOMATIC AIR CONDITIONING]

SUNLOAD SENSOR

Removal and Installation

INFOID:000000011136216

REMOVAL

1. Remove the instrument panel tweeter grille LH. Refer to [IP-14. "Exploded View"](#).
2. Disconnect the harness connector from the sunload sensor.
3. Release the pawls, then remove sunload sensor (1) from the instrument panel tweeter grille LH.

○: Pawl

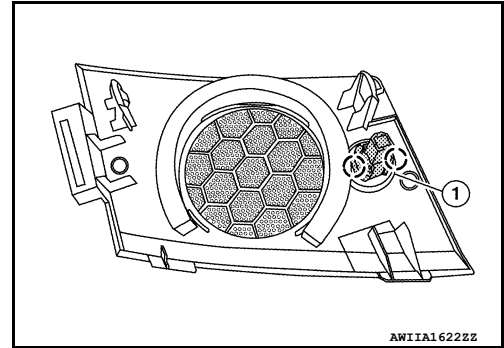

INSTALLATION

Installation is in the reverse order of removal.

INTAKE SENSOR

< REMOVAL AND INSTALLATION >

[AUTOMATIC AIR CONDITIONING]

INTAKE SENSOR

Removal and Installation

INFOID:000000011136217

The intake sensor is not serviced separately. Refer to [HA-50. "Removal and Installation - Front Evaporator"](#).

A

B

C

D

E

F

G

H

HAC

J

K

L

M

N

O

P

EXHAUST GAS/OUTSIDE ODOR DETECTING SENSOR

< REMOVAL AND INSTALLATION >

[AUTOMATIC AIR CONDITIONING]

EXHAUST GAS/OUTSIDE ODOR DETECTING SENSOR

Removal and Installation

INFOID:000000011136218

REMOVAL

1. Remove the core support cover. Refer to [EXT-16. "Exploded View"](#).
2. Disconnect the harness connector from the exhaust gas/outside odor detecting sensor.
3. Remove the nut (A), and the exhaust gas/outside odor detecting sensor (1).

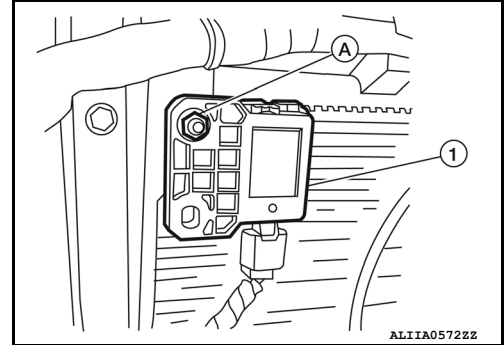

INSTALLATION

Installation is in the reverse order of removal.

REFRIGERANT PRESSURE SENSOR

< REMOVAL AND INSTALLATION >

[AUTOMATIC AIR CONDITIONING]

REFRIGERANT PRESSURE SENSOR

Removal and Installation

INFOID:000000011136219

REMOVAL

1. Discharge the refrigerant. Refer to [HA-23, "Recycle Refrigerant"](#).
2. Remove the core support cover. Refer to [EXT-16, "Exploded View"](#).
3. Disconnect the harness connector from the refrigerant pressure sensor.
4. Remove the refrigerant pressure sensor (1).

CAUTION:

Cap or wrap the opening of the refrigerant pressure sensor with suitable material such as vinyl tape to avoid the entry of air.

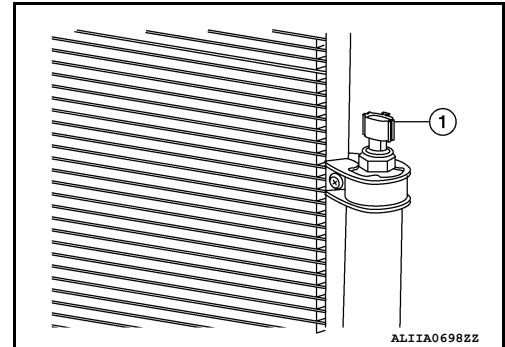

INSTALLATION

Installation is in the reverse order of removal.

CAUTION:

- Do not reuse O-ring.
- Apply A/C oil to the O-ring of the refrigerant pressure sensor for installation.
- After charging the refrigerant, check for leaks. Refer to [HA-21, "Leak Test"](#).

A
B
C
D
E
F
G
H
J
K
L
M
N
O
P

HAC

DOOR MOTOR

< REMOVAL AND INSTALLATION >

[AUTOMATIC AIR CONDITIONING]

DOOR MOTOR

Exploded View

INFOID:000000011136220

Front Door Motors

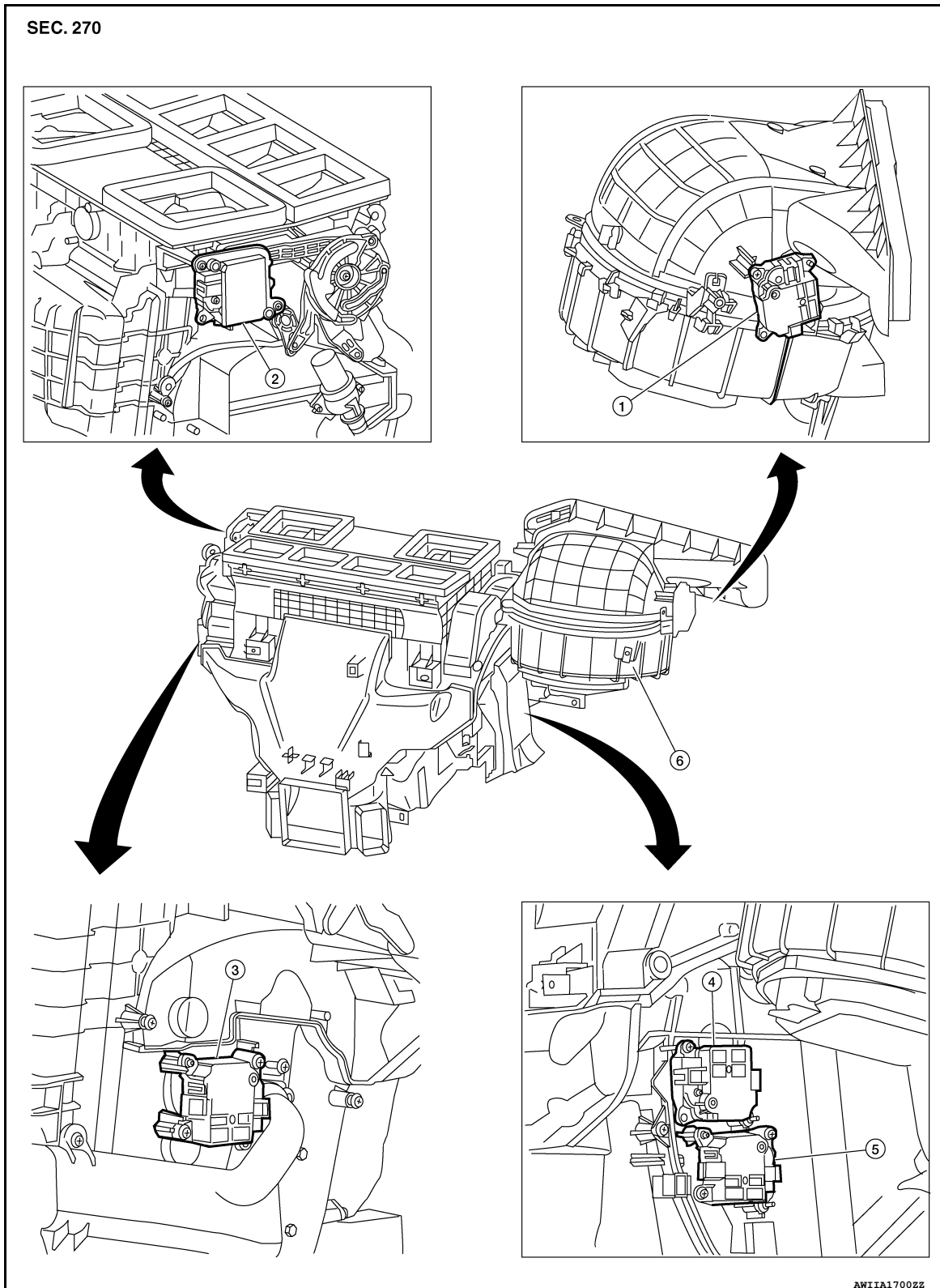

- 1. Intake door motor
- 2. Mode door motor (front)
- 3. Air mix door motor (driver side)
- 4. Air mix door motor (passenger side)
- 5. Air mix door motor (rear)
- 6. Front heating and cooling unit assembly

DOOR MOTOR

< REMOVAL AND INSTALLATION >

[AUTOMATIC AIR CONDITIONING]

Rear Door Motors

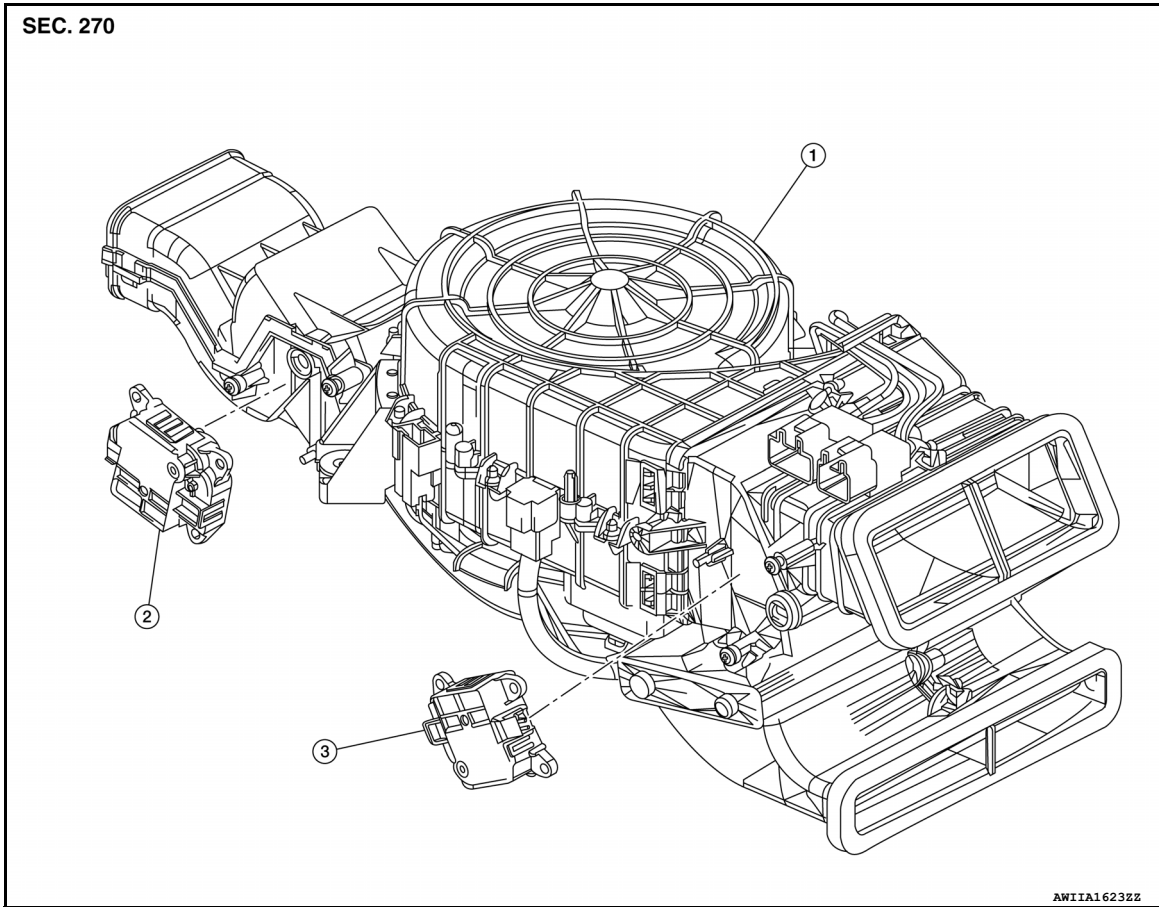

1. Rear blower motor 1 unit assembly 2. Rear shut-off door motor 3. Mode door motor (rear)

MODE DOOR MOTOR

MODE DOOR MOTOR : Removal and Installation - Mode Door Motor (Front)

INFOID:000000011136221

REMOVAL

1. Remove the center console side finisher (LH). Refer to [IP-18. "Exploded View"](#).
2. Remove the upper floor connecting duct LH. Refer to [HA-44. "Exploded View"](#).
3. Remove the mode door motor (front) screws.
4. Disconnect the harness connector from the mode door motor (front) and remove.

INSTALLATION

Installation is in the reverse order of removal.

MODE DOOR MOTOR : Removal and Installation - Mode Door Motor (Rear)

INFOID:000000011136222

REMOVAL

1. Remove the center console assembly. Refer to [IP-18. "Removal and Installation"](#).
2. Disconnect the harness connectors from the PTC heater.
3. Remove the screws from the mode door motor (rear).
4. Disconnect the harness connector from the mode door motor (rear) and remove.

INSTALLATION

Installation is in the reverse order of removal.

AIR MIX DOOR MOTOR

A
B
C
D
E
F
G
H
J
K
L
M
N
O
P

HAC

DOOR MOTOR

< REMOVAL AND INSTALLATION >

[AUTOMATIC AIR CONDITIONING]

AIR MIX DOOR MOTOR : Removal and Installation - Air Mix Door Motor (Driver Side)

INFOID:000000011136223

REMOVAL

1. Remove the center console side finisher (LH). Refer to [IP-18, "Exploded View"](#).
2. Remove the upper floor connecting duct LH. Refer to [HA-44, "Exploded View"](#).
3. Remove the air mix door motor (driver side) screws.
4. Disconnect the harness connector from the air mix door motor (driver side) and remove.

INSTALLATION

Installation is in the reverse order of removal.

AIR MIX DOOR MOTOR : Removal and Installation - Air Mix Door Motor (Passenger Side)

INFOID:000000011136224

REMOVAL

1. Remove the center console side finisher (RH). Refer to [IP-18, "Exploded View"](#).
2. Remove the upper floor connecting duct RH. Refer to [HA-44, "Exploded View"](#).
3. Remove the air mix door motor (passenger side) screws.
4. Disconnect the harness connector from the air mix door motor (passenger side) and remove.

INSTALLATION

Installation is in the reverse order of removal.

AIR MIX DOOR MOTOR : Removal and Installation - Air Mix Door Motor (Rear)

INFOID:000000011136225

REMOVAL

1. Remove the upper floor connecting duct RH. Refer to [HA-44, "Exploded View"](#).
2. Remove the air mix door motor (rear) screws.
3. Disconnect the harness connector from the air mix door motor (rear) and remove.

INSTALLATION

Installation is in the reverse order of removal.

INTAKE DOOR MOTOR

INTAKE DOOR MOTOR : Removal and Installation

INFOID:000000011136226

REMOVAL

1. Remove the glove box assembly. Refer to [IP-26, "Removal and Installation"](#).
2. Remove the intake door motor screws.
3. Disconnect the harness connector from the intake door motor and remove.

INSTALLATION

Installation is in the reverse order of removal.

REAR SHUT-OFF DOOR MOTOR

REAR SHUT-OFF DOOR MOTOR : Removal and Installation

INFOID:000000011136227

REMOVAL

1. Remove the center console rear brace. Refer to [IP-18, "Exploded View"](#).
2. Remove the rear shut-off door motor screws.
3. Disconnect the harness connector from the rear shut-off door motor and remove.

INSTALLATION

Installation is in the reverse order of removal.

BLOWER MOTOR RESISTOR

< REMOVAL AND INSTALLATION >

[AUTOMATIC AIR CONDITIONING]

BLOWER MOTOR RESISTOR

Removal and Installation - Rear Blower Motor Resistor 1

INFOID:000000011136228

REMOVAL

1. Remove the rear blower motor 1 unit assembly. Refer to [VTL-20, "REAR BLOWER MOTOR 1 UNIT ASSEMBLY : Removal and Installation"](#).
2. Disconnect the harness connector from the rear blower motor resistor 1.
3. Remove the screw and the rear blower motor resistor 1.

INSTALLATION

Installation is in the reverse order of removal.

Removal and Installation - Rear Blower Motor Resistor 2

INFOID:000000011136229

REMOVAL

1. Remove the luggage side lower finisher (RH). Refer to [INT-31, "LUGGAGE SIDE LOWER FINISHER : Removal and Installation"](#).
2. Disconnect the harness connector from the rear blower motor resistor 2.
3. Remove the screws and the rear blower motor resistor 2.

INSTALLATION

Installation is in the reverse order of removal.

A

B

C

D

E

F

G

H

HAC

J

K

L

M

N

O

P

IONIZER

< REMOVAL AND INSTALLATION >

[AUTOMATIC AIR CONDITIONING]

IONIZER

Exploded View

INFOID:000000011136230

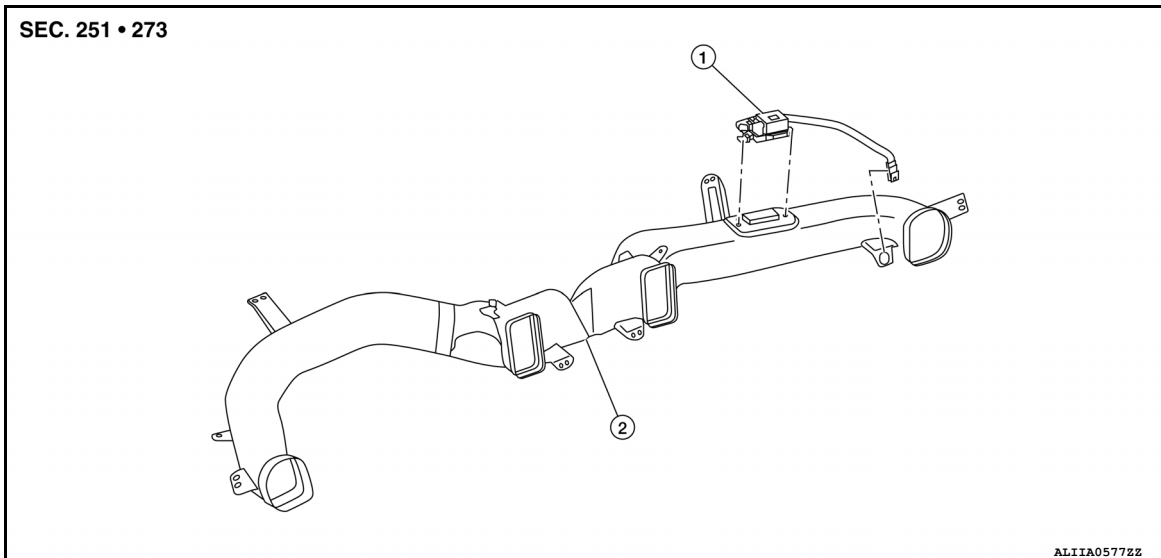

1. Ionizer

2. Center ventilator duct

Removal and Installation

INFOID:000000011136231

Removal

1. Remove instrument panel assembly. Refer to [IP-15, "Removal and Installation"](#).
2. Disconnect the harness connector from the ionizer.
3. Release the ionizer clips, then remove ionizer from the center ventilator duct.

INSTALLATION

Installation is in the reverse order of removal.

CAUTION:

- If there is dirt, use a clean cloth and clean the discharge electrode (ceramic part) of the ionizer.
- Do not touch the surface (ceramic part) of the ionizer, it is the discharge electrode.