

SECTION **MA**  
 MAINTENANCE

A  
B  
C  
D  
E  
F  
G  
H  
I  
J  
K  
L  
M  
N  
O

CONTENTS

<b>PRECAUTION</b> .....	3	<b>FOR MEXICO</b> .....	16
<b>PRECAUTIONS</b> .....	3	FOR MEXICO : Fluids and Lubricants .....	16
Precaution for Supplemental Restraint System (SRS) "AIR BAG" and "SEAT BELT PRE-TENSIONER" .....	3	FOR MEXICO : Engine Coolant Mixture Ratio .....	18
<b>PREPARATION</b> .....	4	<b>ENGINE MAINTENANCE (VQ35DE)</b> .....	19
<b>PREPARATION</b> .....	4	<b>DRIVE BELTS</b> .....	19
Special Service Tool .....	4	DRIVE BELTS : Checking Drive Belts .....	19
Commercial Service Tool .....	4	DRIVE BELTS : Tension Adjustment .....	19
<b>PERIODIC MAINTENANCE</b> .....	5	<b>ENGINE COOLANT</b> .....	19
<b>GENERAL MAINTENANCE</b> .....	5	ENGINE COOLANT : System Inspection .....	19
<b>FOR USA AND CANADA</b> .....	5	ENGINE COOLANT : Changing Engine Coolant .....	21
FOR USA AND CANADA : Explanation of General Maintenance .....	5	<b>FUEL LINES</b> .....	24
<b>FOR MEXICO</b> .....	6	FUEL LINES : Inspection .....	24
FOR MEXICO : General Maintenance .....	7	<b>AIR CLEANER FILTER</b> .....	24
<b>PERIODIC MAINTENANCE</b> .....	9	AIR CLEANER FILTER : Exploded View .....	25
<b>FOR USA AND CANADA</b> .....	9	AIR CLEANER FILTER : Removal and Installation .....	25
FOR USA AND CANADA : Introduction of Periodic Maintenance .....	9	<b>ENGINE OIL</b> .....	25
<b>FOR MEXICO</b> .....	12	ENGINE OIL : Inspection .....	25
FOR MEXICO : Introduction of Periodic Maintenance .....	12	ENGINE OIL : Changing Engine Oil .....	26
<b>RECOMMENDED FLUIDS AND LUBRICANTS</b> .....	15	<b>OIL FILTER</b> .....	26
<b>FOR USA AND CANADA</b> .....	15	OIL FILTER : Removal and Installation .....	26
FOR USA AND CANADA : Fluids and Lubricants... ..	15	<b>SPARK PLUG</b> .....	27
FOR USA AND CANADA : Engine Oil Recommendation .....	16	SPARK PLUG : Exploded View .....	28
FOR USA AND CANADA : Engine Coolant Mixture Ratio .....	16	SPARK PLUG : Removal and Installation .....	28
		<b>EVAP VAPOR LINES</b> .....	29
		EVAP VAPOR LINES : Inspection .....	29
		<b>CHASSIS AND BODY MAINTENANCE</b> .....	30
		<b>IN-CABIN MICROFILTER</b> .....	30
		IN-CABIN MICROFILTER : Removal and Installation .....	30
		<b>EXHAUST SYSTEM</b> .....	30
		EXHAUST SYSTEM : Inspection .....	30

MA

<b>CVT FLUID</b> .....	<b>30</b>	<b>FRONT BRAKE</b> .....	<b>40</b>
CVT FLUID : Inspection .....	31	FRONT BRAKE : Inspection of Pad .....	40
CVT FLUID : Changing .....	31	FRONT BRAKE : Inspection of Rotor .....	40
<b>TRANSFER OIL</b> .....	<b>33</b>	<b>REAR BRAKE</b> .....	<b>40</b>
TRANSFER OIL : Inspection .....	33	REAR BRAKE : Inspection of Pad .....	40
TRANSFER OIL : Draining .....	33	REAR BRAKE : Inspection of Rotor .....	40
TRANSFER OIL : Refilling .....	33	<b>STEERING GEAR AND LINKAGE</b> .....	<b>41</b>
<b>REAR DIFFERENTIAL GEAR OIL</b> .....	<b>34</b>	STEERING GEAR AND LINKAGE : Inspection .....	41
REAR DIFFERENTIAL GEAR OIL : Inspection .....	34	<b>POWER STEERING FLUID AND LINES</b> .....	<b>41</b>
REAR DIFFERENTIAL GEAR OIL : Draining .....	34	POWER STEERING FLUID AND LINES : Inspec-	
REAR DIFFERENTIAL GEAR OIL : Refilling .....	35	tion .....	41
<b>PROPELLER SHAFT</b> .....	<b>35</b>	<b>AXLE AND SUSPENSION PARTS</b> .....	<b>42</b>
PROPELLER SHAFT : Inspection .....	35	AXLE AND SUSPENSION PARTS : Inspection .....	42
<b>WHEELS</b> .....	<b>36</b>	<b>DRIVE SHAFT</b> .....	<b>42</b>
WHEELS : Inspection .....	36	DRIVE SHAFT : Inspection .....	43
WHEELS : Adjustment .....	36	<b>LOCKS, HINGES AND HOOD LATCH</b> .....	<b>43</b>
<b>BRAKE FLUID LEVEL AND LEAKS</b> .....	<b>38</b>	LOCKS, HINGES AND HOOD LATCH : Lubricat-	
BRAKE FLUID LEVEL AND LEAKS : Inspection .....	38	ing .....	43
<b>BRAKE LINES AND CABLES</b> .....	<b>38</b>	<b>SEAT BELT, BUCKLES, RETRACTORS, AN-</b>	
BRAKE LINES AND CABLES : Inspection .....	39	<b>CHORS AND ADJUSTERS</b> .....	<b>43</b>
<b>BRAKE FLUID</b> .....	<b>39</b>	SEAT BELT, BUCKLES, RETRACTORS, AN-	
BRAKE FLUID : Drain and Refill .....	39	CHORS AND ADJUSTERS : Inspection .....	43

# PRECAUTIONS

< PRECAUTION >

## PRECAUTION

### PRECAUTIONS

#### Precaution for Supplemental Restraint System (SRS) "AIR BAG" and "SEAT BELT PRE-TENSIONER"

INFOID:000000011131980

The Supplemental Restraint System such as "AIR BAG" and "SEAT BELT PRE-TENSIONER", used along with a front seat belt, helps to reduce the risk or severity of injury to the driver and front passenger for certain types of collision. This system includes dual stage front air bag modules. The SRS system may only deploy one front air bag, depending on the severity of a collision and whether the front passenger seat is occupied. Information necessary to service the system safely is included in the SR and SB section of this Service Manual.

#### **WARNING:**

- To avoid rendering the SRS inoperative, which could increase the risk of personal injury or death in the event of a collision which would result in air bag inflation, all maintenance must be performed by an authorized NISSAN/INFINITI dealer.
- Improper maintenance, including incorrect removal and installation of the SRS, can lead to personal injury caused by unintentional activation of the system. For removal of Spiral Cable and Air Bag Module, see the SR section.
- Do not use electrical test equipment on any circuit related to the SRS unless instructed to in this Service Manual. SRS wiring harnesses can be identified by yellow and/or orange harnesses or harness connectors.

#### PRECAUTIONS WHEN USING POWER TOOLS (AIR OR ELECTRIC) AND HAMMERS

#### **WARNING:**

- When working near the Airbag Diagnosis Sensor Unit or other Airbag System sensors with the Ignition ON or engine running, DO NOT use air or electric power tools or strike near the sensor(s) with a hammer. Heavy vibration could activate the sensor(s) and deploy the air bag(s), possibly causing serious injury.
- When using air or electric power tools or hammers, always switch the Ignition OFF, disconnect the battery and wait at least three minutes before performing any service.

A  
B  
C  
D  
E  
F  
G  
H  
I  
J  
K  
L  
M  
N  
O

MA

# PREPARATION

< PREPARATION >

## PREPARATION

### PREPARATION

#### Special Service Tool

INFOID:000000011131981

The actual shape of the tools may differ from those illustrated here.

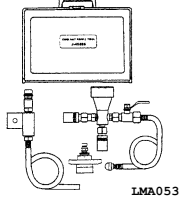
Tool number (TechMate No.) Tool name	Description
KV991J0070 (J-45695) Coolant Refill Tool <div data-bbox="701 506 878 701" style="text-align: center;">  <p>LMA053</p> </div>	Refilling engine cooling system

#### Commercial Service Tool

INFOID:000000011131982

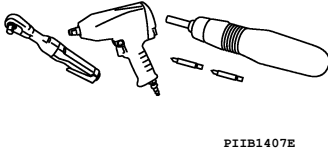
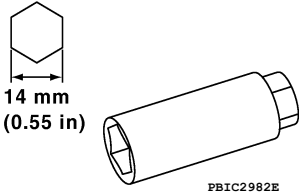
Tool name	Description
Power tool <div data-bbox="609 953 935 1102" style="text-align: center;">  <p>PIIB1407E</p> </div>	Loosening nuts, screws and bolts
Spark plug wrench <div data-bbox="625 1161 922 1352" style="text-align: center;">  <p>14 mm (0.55 in)</p> <p>PBIC2982E</p> </div>	Removing and installing spark plug

# GENERAL MAINTENANCE

< PERIODIC MAINTENANCE >

## PERIODIC MAINTENANCE

### GENERAL MAINTENANCE FOR USA AND CANADA

#### FOR USA AND CANADA : Explanation of General Maintenance

INFOID:000000011131983

General maintenance includes those items which should be checked during the normal day-to-day operation of the vehicle. They are essential if the vehicle is to continue operating properly. The owners can perform checks and inspections themselves or have their INFINITI retailers do them.

#### OUTSIDE THE VEHICLE

The maintenance items listed here should be performed from time to time, unless otherwise specified.

Item		Reference page
<b>Tires</b>	Check the pressure with a gauge often and always prior to long distance trips. Adjust the pressure in all tires, including the spare, to the pressure specified. Check carefully for damage, cuts or excessive wear.	<a href="#">MA-36</a>
<b>Wheel nuts</b>	When checking the tires, make sure no nuts are missing, and check for any loose nuts. Tighten if necessary.	<a href="#">MA-36</a>
<b>Tire rotation</b>	Tires should be rotated every 5,000 miles (8,000 km).	<a href="#">MA-36</a>
<b>Tire pressure monitoring system (TPMS) transmitter components</b>	Replace the TPMS transmitter grommet seal, valve core and cap when the tires are replaced due to wear or age.	<a href="#">MA-36</a>
<b>Wheel alignment and balance</b>	If the vehicle should pull to either side while driving on a straight and level road or if you detect uneven or abnormal tire wear, there may be a need for wheel alignment. If the steering wheel or seat vibrates at normal highway speeds, wheel balancing may be needed. For additional information regarding tires, refer to "Important Tire Safety Information" (US) or "Tire Safety Information" (Canada) in the INFINITI Warranty Information Booklet.	<a href="#">FSU-22, WT-52</a>
<b>Windshield</b>	Clean the windshield on a regular basis. Check the windshield at least every six months for cracks or other damage. Repair as necessary.	—
<b>Windshield wiper blades</b>	Check for cracks or wear if they do not wipe properly.	—
<b>Doors and engine hood</b>	Check that all doors and the engine hood operate smoothly as well as the back door, trunk lid and glass hatch. Also make sure that all latches lock securely. Lubricate if necessary. Make sure that the secondary latch keeps the hood from opening when the primary latch is released. When driving in areas using road salt or other corrosive materials, check for lubrication frequently.	<a href="#">MA-43</a>
<b>Lamps</b>	Make sure that the headlamps, stop lamps, tail lamps, turn signal lamps and other lamps are all operating properly and installed securely. Also check headlamp aim. Clean the headlamps on a regular basis.	<a href="#">EXL-162</a>

#### INSIDE THE VEHICLE

The maintenance items listed here should be checked on a regular basis, such as when performing periodic maintenance, cleaning the vehicle, etc.

Item		Reference page
<b>Warning lamps and chimes</b>	Make sure that all warning lamps and chimes are operating properly.	—
<b>Windshield wiper and washer</b>	Check that the wipers and washer operate properly and that the wipers do not streak.	—
<b>Windshield defroster</b>	Check that the air comes out of the defroster outlets properly and in sufficient quantity when operating the heater or air conditioner.	—
<b>Steering wheel</b>	Check that it has the specified play. Check for changes in the steering condition, such as excessive play, hard steering or strange noises. <b>Free play: Less than 35 mm (1.38 in)</b>	<a href="#">ST-47</a>

## GENERAL MAINTENANCE

### < PERIODIC MAINTENANCE >

Item		Reference page
<b>Seats</b>	Check seat position controls such as seat adjusters, seatback recliner, etc. to make sure they operate smoothly and that all latches lock securely in every position. Check that the head restraints move up and down smoothly and that the locks (if equipped) hold securely in all latched positions. Check that the latches lock securely for folding-down rear seatbacks.	—
<b>Seat belts</b>	Check that all parts of the seat belt system (e.g., buckles, anchors, adjusters and retractors) operate properly and smoothly and are installed securely. Check the belt webbing for cuts, fraying, wear or damage.	<a href="#">MA-43</a>
<b>Accelerator pedal</b>	Check the pedal for smooth operation and make sure the pedal does not catch or require uneven effort. Keep the floor mats away from the pedal.	—
<b>Brakes</b>	Check that the brake does not pull the vehicle to one side when applied.	—
<b>Brake pedal and booster</b>	Check the pedal for smooth operation and make sure it has the proper distance under it when depressed fully. Check the brake booster function. Be sure to keep the floor mats away from the pedal.	<a href="#">BR-20</a> , <a href="#">BR-31</a>
<b>Parking brake</b>	Check that the lever or pedal has the proper travel and make sure that the vehicle is held securely on a fairly steep hill when only the parking brake is applied.	<a href="#">PB-7</a>
<b>CVT P (Park) position mechanism</b>	On a fairly steep hill check that the vehicle is held securely with the shift selector in the P (Park) position without applying any brakes.	—

### UNDER THE HOOD AND VEHICLE

The maintenance items listed here should be checked periodically (e.g., each time you check the engine oil or refuel).

Item		Reference page
<b>Windshield washer fluid</b>	Check that there is adequate fluid in the tank.	—
<b>Engine coolant level</b>	Check the coolant level when the engine is cold.	<a href="#">CO-10</a>
<b>Radiator and hoses</b>	Check the front of the radiator and clean off any dirt, insects, leaves, etc., that may have accumulated. Make sure the hoses have no cracks, deformation, deterioration or loose connections.	—
<b>Brake fluid level</b>	Make sure that the brake fluid level is between the MAX and MIN lines on the reservoir.	<a href="#">MA-38</a>
<b>Battery</b>	Check the fluid level in each cell. It should be between the MAX and MIN lines. Vehicles operated in high temperatures or under severe conditions require frequent checks of the battery fluid level.	<a href="#">PG-99</a>
<b>Engine drive belts</b>	Make sure that no belt is frayed, worn, cracked or oily.	<a href="#">MA-19</a>
<b>Engine oil level</b>	Check the level on the oil level gauge after parking the vehicle on a level spot and turning off the engine.	<a href="#">MA-25</a>
<b>Power steering fluid level and lines</b>	Check the level on the dipstick with the engine off. Check the lines for improper attachment, leaks, cracks, etc.	<a href="#">MA-41</a>
<b>Exhaust system</b>	Make sure there are no loose supports, cracks or holes. If the sound of the exhaust seems unusual or there is a smell of exhaust fumes, immediately locate the trouble and correct it.	<a href="#">MA-30</a>
<b>Underbody</b>	The underbody is frequently exposed to corrosive substances such as those used on icy roads or to control dust. It is very important to remove these substances, otherwise rust will form on the floor pan, frame, fuel lines and around the exhaust system. At the end of winter, the underbody should be thoroughly flushed with plain water, being careful to clean those areas where mud and dirt can easily accumulate.	—
<b>Fluid leaks</b>	Check under the vehicle for fuel, oil, water or other fluid leaks after the vehicle has been parked for a while. Water dripping from the air conditioner after use is normal. If you should notice any leaks or gasoline fumes are evident, check for the cause and correct it immediately.	—

### FOR MEXICO

# GENERAL MAINTENANCE

< PERIODIC MAINTENANCE >

## FOR MEXICO : General Maintenance

INFOID:000000011131984

General maintenance includes those items which should be checked during the normal day-to-day operation of the vehicle. They are essential if the vehicle is to continue operating properly. The owners can perform the checks and inspections themselves or they can have their **INFINITI** dealers do them.

### OUTSIDE THE VEHICLE

The maintenance items listed here should be performed from time to time, unless otherwise specified.

Item	Reference page	
<b>Doors and hood</b>	Check that all doors and the hood operate smoothly as well as the back door, trunk lid and hatch. Also make sure that all latches lock securely. Lubricate if necessary. Make sure that the secondary latch keeps the hood from opening when the primary latch is released. When driving in areas using road salt or other corrosive materials, check lubrication frequently.	<a href="#">MA-43</a>
<b>Lamps</b>	Clean the headlamps on a regular basis. Make sure that the headlamps, stop lamps, tail lamps, turn signal lamps, and other lamps are all operating properly installed securely. Also check the aim of the headlamps.	—
<b>Tires</b>	Check the pressure with a gauge often and always prior to long distance trips. Adjust the pressure in all tires, including the spare, to the pressure specified. Check carefully for damage, cuts or excessive wear.	<a href="#">WT-61</a>
<b>Tire rotation</b>	In the case that Two-Wheel Drive (2WD) and front & rear tires are same size; Tires should be rotated every 10,000 km (6,000 miles). Tires marked with directional indicators can only be rotated between front and rear. Make sure that the directional indicators point in the direction of wheel rotation after the tire rotation is completed. In the case that Four-Wheel Drive (4WD) and front & rear tires are same size; Tires should be rotated every 5,000 km (3,000 miles). Tires marked with directional indicators can only be rotated between front and rear. Make sure that the directional indicators point in the direction of wheel rotation after the tire rotation is completed. In the case that front tires are different size from rear tires; Tires cannot be rotated. However, the timing for tire rotation may vary according to your driving habits and the road surface conditions.	<a href="#">WT-53</a>
<b>Tire Pressure Monitoring System (TPMS) transmitter components</b>	Replace the TPMS transmitter grommet seal, valve core and cap when the tires are replaced due to wear or age.	<a href="#">WT-56</a>
<b>Wheel alignment and balance</b>	If the vehicle should pull to either side while driving on a straight and level road, or if you detect uneven or abnormal tire wear, there may be a need for wheel alignment. If the steering wheel or seat vibrates at normal highway speeds, wheel balancing may be needed.	<a href="#">FSU-5</a>
<b>Windshield</b>	Clean the windshield on a regular basis. Check the windshield at least every six months for cracks or other damage. Repair as necessary.	—
<b>Wiper blades</b>	Check for cracks or wear if not functioning correctly. Repair as necessary.	—

### INSIDE THE VEHICLE

The maintenance items listed here should be checked on a regular basis, such as when performing periodic maintenance, cleaning the vehicle, etc.

Item	Reference page	
<b>Accelerator pedal</b>	Check the pedal for smooth operation and make sure that the pedal does not catch or require uneven effort. Keep the floor mats away from the pedal.	—
<b>Brake pedal</b>	Check the pedal for smooth operation and make sure that it is the proper distance from the floor mat when depressed fully. Check the brake booster function. Be sure to keep the floor mats away from the pedal.	<a href="#">BR-7</a>
<b>Parking brake</b>	Check the parking brake operation regularly. Check that the lever (if equipped) or the pedal (if equipped) has the proper travel. Also make sure that the vehicle is held securely on a fairly steep hill when only the parking brake is applied.	<a href="#">PB-4</a>
<b>Seat belts</b>	Check that all parts of the seat belt system (for example, buckles, anchors, adjusters and retractors) operate properly and smoothly, and are installed securely. Check the belt webbing for cuts, fraying, wear or damage.	<a href="#">MA-43</a>
<b>Steering wheel</b>	Check for changes in the steering condition, such as excessive play, hard steering or strange noises. Check that it has the specified play. <b>Free play: Less than 35 mm (1.38 in)</b>	—

## GENERAL MAINTENANCE

### < PERIODIC MAINTENANCE >

	Item	Reference page
<b>Warning lamps and chimes</b>	Make sure that all warning lamps and chimes are operating properly.	—
<b>Windshield defogger</b>	Check that the air comes out of the defogger outlets properly and in good quantity when operating the heater or air conditioner.	—
<b>Windshield wiper and washer</b>	Check that the wipers and washer operate properly and that the wipers do not streak.	—

### UNDER THE HOOD AND VEHICLE

The maintenance items listed here should be checked periodically (for example, each time you check the engine oil or refuel.)

	Item	Reference page
<b>Battery</b>	Except for maintenance free battery; Check the fluid level in each cell. It should be between the "UPPER" and "LOWER" lines. Vehicles operated in high temperatures or under severe conditions require frequent checks of the battery fluid level.	<a href="#">PG-90</a>
<b>Brake (and clutch) fluid level(s)</b>	For Manual Transmission (MT) model; Make sure that the brake and clutch fluid levels are between the "MAX" and "MIN" lines on the reservoir(s). Except for Manual Transmission (MT) model; Make sure that the brake fluid level is between the "MAX" and "MIN" lines on the reservoir.	<a href="#">BR-8</a>
<b>Coolant level</b>	Check the coolant level when the coolant is cold. Make sure that the coolant level is between the "MAX" and "MIN" lines on the reservoir.	<a href="#">CO-10</a>
<b>Engine drive belt(s)</b>	Make sure that drive belt(s) is/are not frayed, worn, cracked or oily.	<a href="#">EM-12</a>
<b>Engine oil level</b>	Check the level after parking the vehicle (on a level ground) and turning off the engine.	<a href="#">LU-8</a>
<b>Fluid leaks</b>	Check under the vehicle for fuel, oil, water or other fluid leaks after the vehicle has been parked for a while. Water dripping from the air conditioner after use is normal. If you should notice any leaks or if fuel fumes are evident, check for cause and have it corrected immediately.	—
<b>Power steering fluid level and lines</b>	Check the level when the fluid is cold, with the engine off. Check the lines for proper attachment, leaks, cracks, etc.	<a href="#">ST-21</a>
<b>Windshield washer fluid</b>	Check that there is adequate fluid in the reservoir.	—



# PERIODIC MAINTENANCE

< PERIODIC MAINTENANCE >

## PERIODIC MAINTENANCE FOR USA AND CANADA

### FOR USA AND CANADA : Introduction of Periodic Maintenance

INFOID:000000011131985

The following tables show the normal maintenance schedule. Depending upon weather and atmospheric conditions, varying road surfaces, individual driving habits and vehicle usage, additional or more frequent maintenance may be required.

**Periodic maintenance beyond the last period shown on the tables requires similar maintenance.**

#### ENGINE AND EMISSION CONTROL MAINTENANCE

Abbreviations: R = Replace, I = Inspect and correct or replace as necessary

MAINTENANCE OPERATION		MAINTENANCE INTERVAL								
Perform either at number of miles, kilometers or months, whichever comes first.	Miles x 1,000 (km x 1,000)	5 (8)	10 (16)	15 (24)	20 (32)	25 (40)	30 (48)	35 (56)	40 (64)	45 (72)
	Months	6	12	18	24	30	36	42	48	48
Drive belts	NOTE (1)								I*	
Air cleaner filter	NOTE (2)						R			
EVAP vapor lines					I*				I*	
Fuel lines					I*				I*	
Fuel filter	NOTE (3)									
Engine coolant*	NOTE (4)(5)									
Engine oil		R	R	R	R	R	R	R	R	R
Engine oil filter (Use genuine NISSAN engine oil filter or equivalent)		R	R	R	R	R	R	R	R	R
Spark plugs (Iridium-tipped type)	NOTE (6)	Replace every 105,000 miles (168,000 km)								
Intake & exhaust valve clearance*	NOTE (7)									

MAINTENANCE OPERATION		MAINTENANCE INTERVAL								
Perform either at number of miles, kilometers or months, whichever comes first.	Miles x 1,000 (km x 1,000)	50 (80)	55 (88)	60 (96)	65 (104)	70 (112)	75 (120)	80 (128)	85 (136)	90 (144)
	Months	60	66	72	78	84	90	96	102	108
Drive belts	NOTE (1)	I*		I*		I*		I*		I*
Air cleaner filter	NOTE (2)			R						R
EVAP vapor lines				I*				I*		
Fuel lines				I*				I*		
Fuel filter	NOTE (3)									
Engine coolant*	NOTE (4)(5)									
Engine oil		R	R	R	R	R	R	R	R	R
Engine oil filter (Use genuine NISSAN engine oil filter or equivalent)		R	R	R	R	R	R	R	R	R
Spark plugs (Iridium-tipped type)	NOTE (6)	Replace every 105,000 miles (168,000 km)								
Intake & exhaust valve clearance*	NOTE (7)									

MAINTENANCE OPERATION		MAINTENANCE INTERVAL						Reference Page
Perform either at number of miles, kilometers or months, whichever comes first.	Miles x 1,000 (km x 1,000)	95 (152)	100 (160)	105 (168)	110 (176)	115 (184)	120 (192)	
	Months	114	120	126	132	138	144	
Drive belts	NOTE (1)		I*		I*		I*	<a href="#">MA-19</a>
Air cleaner filter	NOTE (2)						R	<a href="#">MA-25</a>
EVAP vapor lines			I*				I*	<a href="#">MA-29</a>
Fuel lines			I*				I*	<a href="#">MA-24</a>

A  
B  
C  
D  
E  
F  
G  
H  
I  
J  
K  
L  
M  
N  
O

# PERIODIC MAINTENANCE

## < PERIODIC MAINTENANCE >

MAINTENANCE OPERATION		MAINTENANCE INTERVAL						Reference Page
	Miles x 1,000 (km x 1,000) Months	95 (152) 114	100 (160) 120	105 (168) 126	110 (176) 132	115 (184) 138	120 (192) 144	
Perform either at number of miles, kilometers or months, whichever comes first.								
Fuel filter	NOTE (3)							—
Engine coolant*	NOTE (4)(5)							<a href="#">MA-19</a>
Engine oil		R	R	R	R	R	R	<a href="#">MA-25</a>
Engine oil filter (Use genuine NISSAN engine oil filter or equivalent)		R	R	R	R	R	R	<a href="#">MA-26</a>
Spark plugs (Iridium-tipped type)	NOTE (6)	Replace every 105,000 miles (168,000 km)						<a href="#">MA-28</a>
Intake & exhaust valve clearance*	NOTE (7)							

### NOTE:

- (1) After 40,000 miles (64,000 km) or 48 months, inspect every 10,000 miles (16,000 km) or 12 months. Replace the drive belts if found damaged.
- (2) If operating mainly in dusty conditions, more frequent maintenance may be required.
- (3) Maintenance-free item. For service procedures, refer to FL section.
- (4) First replacement interval is 105,000 miles (168,000 km) or 84 months. After first replacement, replace every 75,000 miles (120,000 km) or 60 months.
- (5) Use only Genuine NISSAN Long Life Antifreeze / Coolant (blue) or equivalent with proper mixture ratio of 50% antifreeze and 50% demineralized or distilled water. Mixing any other type of coolant or the use of non-distilled water will reduce the life expectancy of the factory-fill coolant.
- (6) Replace spark plug when the spark plug gap exceeds 1.4 mm (0.055 in), even if within specified periodic replacement mileage.
- (7) Periodic maintenance is not required. However, if valve noise increases, inspect valve clearance.

\*: Maintenance items and intervals with "\*" are recommended by INFINITI for reliable vehicle operation. The owner need not perform such maintenance in order to maintain the emission warranty or manufacturer recall liability. Other maintenance items and intervals are required.

## CHASSIS AND BODY MAINTENANCE

Abbreviations: R= Replace. I = Inspect. Correct or replace if necessary.

MAINTENANCE OPERATION		MAINTENANCE INTERVAL								
	Miles x 1,000 (km x 1,000) Months	5 (8) 6	10 (16) 12	15 (24) 18	20 (32) 24	25 (40) 30	30 (48) 36	35 (56) 42	40 (64) 48	45 (72) 54
Perform either at number of miles, kilometers or months, whichever comes first.										
Brake line & cables			I		I		I		I	
Brake pads & rotors★			I		I		I		I	
Brake fluid ★					R				R	
CVT fluid	NOTE (1)		I		I		I		I	
Transfer oil & differential gear oil	NOTE (2)		I		I		I		I	
Steering gear and linkage, axle and suspension parts ★					I				I	
Tire rotation	NOTE (3)									
Propeller shaft (AWD) & drive shaft boots★			I		I		I		I	
Exhaust system★					I				I	
In-cabin microfilter				R			R			R

MAINTENANCE OPERATION		MAINTENANCE INTERVAL								
	Miles x 1,000 (km x 1,000) Months	50 (80) 60	55 (88) 66	60 (96) 72	65 (104) 78	70 (112) 84	75 (120) 90	80 (128) 96	85 (136) 102	90 (144) 108
Perform either at number of miles, kilometers or months, whichever comes first.										
Brake line & cables		I		I		I		I		I
Brake pads & rotors ★		I		I		I		I		I

# PERIODIC MAINTENANCE

## < PERIODIC MAINTENANCE >

MAINTENANCE OPERATION	Miles x 1,000 (km x 1,000) Months	MAINTENANCE INTERVAL								
		50 (80) 60	55 (88) 66	60 (96) 72	65 (104) 78	70 (112) 84	75 (120) 90	80 (128) 96	85 (136) 102	90 (144) 108
Perform either at number of miles, kilometers or months, whichever comes first.										
Brake fluid ★				R				R		
CVT fluid	NOTE (1)	I		I		I		I		I
Transfer oil & differential gear oil	NOTE (2)	I		I		I		I		I
Steering gear and linkage, axle and suspension parts ★				I				I		
Tire rotation	NOTE (3)									
Propeller shaft (AWD) & drive shaft boots★		I		I		I		I		I
Exhaust system★				I				I		
In-cabin microfilter				R			R			R

MAINTENANCE OPERATION	Miles x 1,000 (km x 1,000) Months	MAINTENANCE INTERVAL						Reference Page
		95 (152) 114	100 (160) 120	105 (168) 126	110 (176) 132	115 (184) 138	120 (192) 90	
Perform either at number of miles, kilometers or months, whichever comes first.								
Brake line & cables			I		I		I	<a href="#">MA-38</a>
Brake pads & rotors ★			I		I		I	<a href="#">MA-40</a> <a href="#">MA-40</a>
Brake fluid ★			R				R	<a href="#">MA-39</a>
CVT fluid	NOTE (1)		I		I		I	<a href="#">MA-31</a>
Transfer oil & differential gear oil	NOTE (2)		I		I		I	<a href="#">MA-33</a>
Steering gear and linkage, axle and suspension parts ★			I				I	<a href="#">MA-41</a> <a href="#">MA-42</a>
Tire rotation	NOTE (3)							<a href="#">MA-36</a>
Propeller shaft (AWD) & drive shaft boots★			I		I		I	<a href="#">MA-43</a> <a href="#">MA-35</a>
Exhaust system★			I				I	<a href="#">MA-30</a>
In-cabin microfilter				R			R	<a href="#">MA-30</a>

**NOTE:**

- Maintenance items with “★” should be performed more frequently according to “Maintenance Under Severe Driving Conditions”.
- (1) Use only Genuine NISSAN CVT fluid. If towing a trailer, using a camper or a car-top carrier, of driving on rough or muddy roads, inspect CVT fluid deterioration at an INFINITI retailer every 60,000 miles (96,000 km), then change CVT fluid if necessary. And if the inspection is not performed, change (not just inspect) CVT fluid every 60,000 miles (96,000 km).
- (2) If tower a trailer, using a camper or car-top carrier, or driving on rough or muddy roads, change (not just inspect) oil at every 20,000 miles (32,000 km) or 24 months.
- (3) Refer to "Tire rotation" under "GENERAL MAINTENANCE" heading earlier in this section.

### MAINTENANCE UNDER SEVERE DRIVING CONDITIONS

The maintenance intervals shown on the preceding pages are for normal operating conditions. If the vehicle is mainly operated under severe driving conditions as shown below, more frequent maintenance must be performed on the following items as shown in the table.

**Severe driving conditions**

- Repeated short trips of less than 5 miles (8 km).
- Repeated short trips of less than 10 miles (16 km) with outside temperatures remaining below freezing.
- Operating in hot weather in stop-and-go "rush hour" traffic.
- Extensive idling and/or low speed driving for long distances, such as police, taxi or door-to-door delivery use.
- Driving in dusty conditions.
- Driving on rough, muddy, or salt spread roads.
- Towing a trailer, using a camper or a car-top carrier

A  
B  
C  
D  
E  
F  
G  
H  
I  
J  
K  
L  
M  
N  
O

MA

# PERIODIC MAINTENANCE

< PERIODIC MAINTENANCE >

Maintenance operation: Check = Check and correct or replace as necessary.

Maintenance item	Maintenance operation	Maintenance interval	Reference page
Brake fluid	Replace	Every 10,000 miles (16,000 km) or 12 months	<a href="#">MA-39</a>
Brake pads & rotors	Inspect	Every 5,000 miles (8,000 km) or 6 months	<a href="#">MA-40</a> <a href="#">MA-40</a> <a href="#">MA-40</a> <a href="#">MA-40</a>
Steering gear & linkage, axle & suspension parts	Inspect	Every 5,000 miles (8,000 km) or 6 months	<a href="#">MA-41</a> <a href="#">MA-42</a>
Propeller shaft (AWD) & drive shaft boots	Inspect	Every 5,000 miles (8,000 km) or 6 months	<a href="#">MA-35</a> <a href="#">MA-43</a>
Exhaust system	Inspect	Every 5,000 miles (8,000 km) or 6 months	<a href="#">MA-30</a>

## FOR MEXICO

### FOR MEXICO : Introduction of Periodic Maintenance

INFOID:000000011131986

The following tables show the normal maintenance schedule. Depending upon weather and atmospheric conditions, varying road surfaces, individual driving habits and vehicle usage, additional or more frequent maintenance may be required.

**Periodic maintenance beyond the last period shown on the tables requires similar maintenance.**

### ENGINE AND EMISSION CONTROL MAINTENANCE

Abbreviations: I = Inspect and correct or replace as necessary, R = Replace, E = Check and correct the engine coolant mixture ratio

MAINTENANCE OPERATION		MAINTENANCE INTERVAL								Reference page
Perform either at number of kilometers (miles) or months, whichever comes first.	km x 1,000 (Miles x 1,000) Months	12 (7.5) 6	24 (15) 12	36 (22.5) 18	48 (30) 24	60 (37.5) 30	72 (45) 36	84 (52.5) 42	96 (60) 48	
<b>Engine compartment and under vehicle</b>										
Intake & exhaust valve clearance	See NOTE (1)									<a href="#">EM-18</a>
Drive belts	See NOTE (2)				I				I	<a href="#">MA-19</a>
Engine oil (Use recommended oil.)★		R	R	R	R	R	R	R	R	<a href="#">MA-25</a>
Engine oil filter (Use Genuine NISSAN engine oil filter or equivalent.)★		R	R	R	R	R	R	R	R	<a href="#">MA-26</a>
Engine coolant	See NOTE (3)				E				E	<a href="#">MA-19</a>
Cooling system					I				I	<a href="#">MA-19</a>
Fuel lines					I				I	<a href="#">MA-24</a>
Air cleaner filter (Viscous paper type)★		Replace every 36,000 km (22,500 miles) or 24 months								<a href="#">MA-25</a>
Fuel filter (In-tank type)	See NOTE (4)									—
Spark plugs (Iridium-tipped type)	See NOTE (5)	Replace every 96,000 km (60,000 miles)								<a href="#">MA-28</a>
EVAP vapor lines (With carbon canister)					I				I	<a href="#">MA-29</a>

#### NOTE:

• Maintenance items with “★” should be performed more frequently according to “Maintenance Under Severe Driving Conditions”.

(1) Periodic maintenance is not required. However, if valve noise increases, check valve clearance.

(2) Replace the drive belts if found damaged or if the auto belt tensioner reading reaches the maximum limit.

(3) Use Genuine NISSAN Engine Coolant (blue) or equivalent in its quality, in order to avoid possible aluminium corrosion within the engine cooling system caused by the use of non-genuine engine coolant. Check and correct the engine coolant mixture ratio every 48,000 km (30,000 miles) or 24 months. First replacement interval is 168,000 km (105,000 miles) or 96 months. After first replacement, replace every 84,000 km (52,500 miles) or 48 months.

# PERIODIC MAINTENANCE

## < PERIODIC MAINTENANCE >

(4) Fuel filter is maintenance-free. For service procedures, refer to FL section.

(5) Replace spark plug when the plug gap exceeds 1.25 mm (0.049 in) even within specified periodic replacement mileage.

## CHASSIS AND BODY MAINTENANCE

Abbreviations: I = Inspect and correct or replace as necessary, R = Replace, L=Lubricate

MAINTENANCE OPERATION	MAINTENANCE INTERVAL										Reference page
	km x 1,000 (Miles x 1,000) Months	12 (7.5) 6	24 (15) 12	36 (22.5) 18	48 (30) 24	60 (37.5) 30	72 (45) 36	84 (52.5) 42	96 (60) 48		
<b>Underhood and under vehicle</b>											
Brake line & cables			I		I		I		I		<a href="#">MA-39</a>
Brake fluid (For level & leaks)			I		I		I		I		<a href="#">BR-8</a>
Brake fluid★					R				R		<a href="#">MA-39</a>
CVT fluid (For level & leaks)	NOTE (1)		I		I		I		I		<a href="#">MA-31</a>
Power steering fluid & lines (For level & leaks)			I		I		I		I		<a href="#">MA-41</a>
Exhaust system					I				I		<a href="#">MA-30</a>
Transfer fluid (For level & leaks)			I		I		I		I		<a href="#">MA-33</a>
Differential gear oil (For level & leaks)★			I		I		I		I		<a href="#">MA-34</a>
Steering gear & linkage, axle & suspension parts★					I				I		<a href="#">MA-41</a> <a href="#">MA-42</a>
Propeller shaft & drive shafts★			I		I		I		I		<a href="#">MA-35</a> <a href="#">MA-43</a>
<b>Outside and inside</b>											
Wheel alignment (If necessary, rotate & balance wheels)			I		I		I		I		<a href="#">FSU-5</a> <a href="#">RSU-6</a>
Brake pads, rotors, drums & linings★			I		I		I		I		<a href="#">MA-40</a> <a href="#">MA-40</a> <a href="#">MA-40</a> <a href="#">MA-40</a>
Foot brake & parking brake (For free play, stroke & operation)			I		I		I		I		<a href="#">PB-4</a>
Air conditioner filter★			R		R		R		R		<a href="#">VTL-6</a>

### NOTE:

★ Maintenance items with “★” should be performed more frequently according to “Maintenance Under Severe Driving Conditions”.

- (1) Use only Genuine NISSAN CVT fluid. If towing a trailer, using a camper or a car-top carrier or driving on a rough or muddy roads, inspect CVT fluid deterioration at INFINITI dealers every 96,000 km (60,000 miles), then change CVT fluid if necessary. And if the inspection is not performed, change (not just inspect) CVT fluid every 96,000 km (60,000 miles).

## MAINTENANCE UNDER SEVERE DRIVING CONDITIONS

The maintenance intervals shown on the preceding pages are for normal operating conditions. If the vehicle is mainly operated under severe driving conditions as shown below, more frequent maintenance must be performed on the following items as shown in the table.

### Severe driving conditions

A — Driving under dusty conditions

B — Driving repeatedly short distances

C — Towing a trailer or caravan

D — Extensive idling

E — Driving in extremely adverse weather conditions or in areas where ambient temperatures are either extremely low or extremely high

F — Driving in high humidity or mountainous areas

# PERIODIC MAINTENANCE

## < PERIODIC MAINTENANCE >

G — Driving in areas using salt or other corrosive areas

H — Driving on rough and/or muddy roads or in the desert

I — Driving with frequent use of braking or in mountainous areas

Maintenance operation: Inspect = Check and correct or replace as necessary.

Driving condition									Maintenance item	Maintenance operation	Maintenance interval	Reference page
A	.	.	.	.	.	.	.	.	Air cleaner filter (Viscous paper type)	Replace	More frequently	<a href="#">MA-25</a>
A	B	C	D	.	.	.	.	.	Engine oil & engine oil filter	Replace	Every 6,000 km (3,750 miles) or 3 months	<a href="#">MA-26</a> <a href="#">MA-26</a>
.	.	.	.	.	F	.	.	.	Brake fluid	Replace	Every 24,000 km (15,000 miles) or 12 months	<a href="#">MA-39</a>
.	.	C	.	.	.	.	H	.	Differential gear oil	Replace	Every 36,000 km (22,500 miles) or 24 months	<a href="#">MA-34</a> <a href="#">MA-34</a> <a href="#">MA-35</a>
.	.	.	.	.	.	G	H	.	Steering gear & linkage, axle & suspension parts	Inspect	Every 24,000 km (15,000 miles) or 12 months	<a href="#">MA-41</a> <a href="#">MA-42</a>
.	.	.	.	.	.	G	H	.	Propeller shaft & drive shafts	Inspect	Every 12,000 km (7,500 miles) or 6 months	<a href="#">MA-35</a> <a href="#">MA-43</a>
A	.	C	.	.	.	G	H	I	Brake pads, rotors, drums & linings	Inspect	Every 12,000 km (7,500 miles) or 6 months	<a href="#">MA-40</a> <a href="#">MA-40</a> <a href="#">MA-40</a> <a href="#">MA-40</a> <a href="#">PB-4</a>
A	.	.	.	.	.	.	.	.	Air conditioner filter	Replace	More frequently	<a href="#">VTL-6</a>

# RECOMMENDED FLUIDS AND LUBRICANTS

< PERIODIC MAINTENANCE >

## RECOMMENDED FLUIDS AND LUBRICANTS FOR USA AND CANADA

FOR USA AND CANADA : Fluids and Lubricants

INFOID:000000011131987

The following are approximate capacities, The actual refill capacities may be slightly different. When refilling, follow the procedures described elsewhere in this manual.

Description		Capacity (Approximate)			Recommended Fluids/Lubricants
		Metric	US measure	Imp measure	
Fuel		74.0 ℓ	19-1/2 gal	16-1/4 gal	Unleaded gasoline with an octane rating of at least 91 AKI (RON 96)
Engine oil Drain and refill	With oil filter change	4.8 ℓ	5-1/8 qt	4-1/4 qt	Genuine NISSAN engine oil or equivalent • Engine oil with API Certification Mark (For further details, see "Engine Oil Recommendation")., Viscosity SAE 0W-20 (As an alternative to this recommended oil, SAE 5W-30 conventional petroleum based oil may be used and meet all specifications and requirements necessary to maintain the New Vehicle Limited Warranty.)
	Without oil filter change	4.5 ℓ	4-3/4 qt	4 qt	
	Dry engine (Overhaul)	5.1 ℓ	5-3/8 qt	4-1/2 qt	
Cooling system (with reservoir at MAX level)		9.6 ℓ	10-1/8 qt	8-1/2 qt	Pre-diluted Genuine NISSAN Long Life Antifreeze/ Coolant (blue) or equivalent
CVT fluid		8.8 ℓ	9-1/4 qt	7-3/4 qt	Genuine NISSAN CVT Fluid NS-3 (Use only Genuine NISSAN CVT Fluid NS-3. Using transmission fluid other than Genuine NISSAN CVT Fluid NS-3 will damage the CVT, which is not covered by the INFINITI new vehicle limited warranty.)
Differential gear oil		0.5 ℓ	1-1/8 pt	7/8 pt	Genuine NISSAN Differential Oil Hypoid Super Semi-synthetic API GL-5, Viscosity SAE 75W-90 (The use of differential gear oil other than the specified may cause vehicle malfunctions and result in non-warranty vehicle repairs.)
Transfer fluid		0.31 ℓ	5/8 pt	1/2 pt	API GL-5, Viscosity SAE 80W-90 or equivalent
Power steering fluid (E-PSF)		1.0 ℓ	2-1/8 pt	1-3/4 pt	Genuine NISSAN E-PSF or equivalent (Use of a power steering fluid other than Genuine NISSAN E-PSF will prevent the power steering system from operating properly.)
Brake fluid		—	—	—	Genuine NISSAN Super Heavy Duty Brake Fluid or equivalent DOT 3 (US FMVSS No. 116) (Available in mainland U.S.A. through an INFINITI retailer.)
Multi-purpose grease		—	—	—	NLGI No. 2 (Lithium soap base)
Windshield washer fluid		5.0 ℓ	5-1/4 qt	4-3/8 qt	Genuine NISSAN Windshield Washer Concentrate Cleaner & Antifreeze or equivalent
Air conditioning system refrigerant		0.80 ± 0.03 kg	1.80 ± 0.07 lb	1.80 ± 0.07 lb	HFC-134a (R-134a) (For further information, see "Air conditioning specification label".)
Air conditioning system oil		230 m ℓ	7.8 fl oz	8.1 fl oz	A/C System Oil Type S (DH-PS) (For further information, see "Air conditioning specification label".)

A  
B  
C  
D  
E  
F  
G  
H  
I  
J  
K  
L  
M  
N  
O

MA

# RECOMMENDED FLUIDS AND LUBRICANTS

< PERIODIC MAINTENANCE >

## FOR USA AND CANADA : Engine Oil Recommendation

INFOID:000000011131988

INFINITI recommends the use of an energy conserving oil in order to improve fuel economy. Select only engine oils that meet the American Petroleum Institute (API) certification and International Lubricant Standardization and Approval Committee (ILSAC) certification and SAE viscosity standard. These oils have the API certification mark on the front of the container. Oils which do not have the specified quality label should not be used as they could cause engine damage.

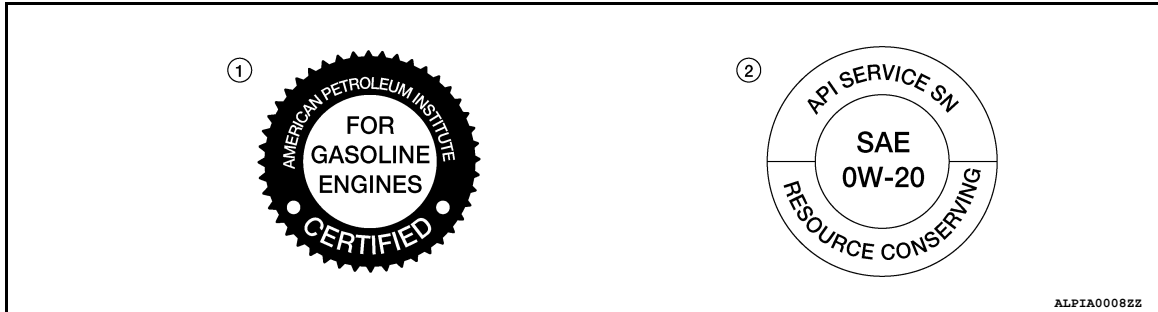

1. API certification mark

2. API service symbol

## FOR USA AND CANADA : Engine Coolant Mixture Ratio

INFOID:000000011131989

The engine cooling system is filled at the factory with a pre-diluted mixture of 50% Genuine NISSAN Long Life Antifreeze/Coolant (blue) and 50% water to provide year-round anti-freeze and coolant protection. The anti-freeze solution contains rust and corrosion inhibitors. Additional engine cooling system additives are not necessary.

### WARNING:

Do not remove the radiator cap when the engine is hot. Serious burns could occur from high-pressure engine coolant escaping from the radiator. Wrap a thick cloth around the cap. Slowly push down and turn it a quarter turn to allow built-up pressure to escape. Carefully remove the cap by pushing it down and turning it all the way.

### CAUTION:

- When adding or replacing coolant, be sure to use only Genuine NISSAN Long Life Antifreeze/Coolant (blue) or equivalent. Genuine NISSAN Long Life Antifreeze/Coolant (blue) is pre-diluted to provide antifreeze protection to -34°F (-37°C). If additional freeze protection is needed due to weather where the vehicle is operated, add Genuine NISSAN long life Antifreeze/Coolant (blue) concentrate following the directions on the container. If an equivalent coolant other than Genuine NISSAN Long Life Antifreeze/Coolant (blue) is used, follow the coolant manufacturer's instructions to maintain minimum antifreeze protection to -34°F (-37°C). The use of other types of coolant solutions other than Genuine NISSAN Long Life Antifreeze/Coolant (blue) or equivalent may damage the engine cooling system.
- Mixing any other type of coolant other than Genuine NISSAN Long Life Antifreeze/Coolant (blue), including Genuine NISSAN Long Life Antifreeze/Coolant (green) or the use of non-distilled water will reduce the life expectancy of the factory filled coolant.

## FOR MEXICO

## FOR MEXICO : Fluids and Lubricants

INFOID:000000011131990

The following are approximate capacities, The actual refill capacities may be slightly different. When refilling, follow the procedures described elsewhere in this manual.

	Capacity (Approximate)			Recommended Fluids/Lubricants
	Metric	US measure	Imp measure	
Fuel	74.0 ℓ	19-1/2 gal	16-1/4 gal	Unleaded gasoline with an octane rating of at least 91 AKI (RON 96)



# RECOMMENDED FLUIDS AND LUBRICANTS

## < PERIODIC MAINTENANCE >

		Capacity (Approximate)			Recommended Fluids/Lubricants	
		Metric	US measure	Imp measure		
Engine oil Drain and refill	With oil filter change	4.8 ℓ	5-1/8 qt	4-1/4 qt	Nippon oil (Genuine NISSAN engine oil API grade SM, Viscosity SAE 5W-30)	A
	Without oil filter change	4.5 ℓ	4-3/4 qt	4 qt		B
	Dry engine (engine overhaul)	5.1 ℓ	5-3/8 qt	4-1/2 qt		C
Cooling system (with reservoir at MAX line)		9.6 ℓ	10-1/8 qt	8-1/2 qt	Genuine NISSAN Engine Coolant (blue) or equivalent (Use Genuine NISSAN Engine Coolant or equivalent in its quality, in order to avoid possible aluminum corrosion within the engine cooling system caused by the use of non-genuine engine coolant. Note that any repairs for the incidents within the engine cooling system while using non-genuine engine coolant may not be covered by the warranty even if such incidents occurred during the warranty period.)	D E F
CVT fluid		8.8 ℓ	9-1/4 qt	7-3/4 qt	Genuine NISSAN CVT fluid NS-3 <b>(Use only Genuine NISSAN CVT Fluid NS-3. Using transmission fluid other than Genuine NISSAN CVT Fluid NS-3 will damage the CVT, which is not covered by the INFINITI new vehicle limited warranty.)</b>	G H
Differential gear oil		0.5 ℓ	1-1/8 pt	7/8 pt	Genuine NISSAN Diff oil Hypoid Super Semi-synthetic GL-5 75W-90 (Use Genuine NISSAN Diff Oil Hypoid Super semi-synthetic GL-5. Using differential gear oil other than Genuine NISSAN Diff Oil Hypoid Super semi-synthetic will damage the differential gear, which is not covered by the warranty.)	I J
Transfer fluid		0.31 ℓ	5/8 pt	1/2 pt	Genuine NISSAN Differential Oil Hypoid Super GL-5 80W-90 or API GL-5, Viscosity SAE 80W-90	K
Power steering fluid		1.0 ℓ	2-1/8 pt	1-3/4 pt	Genuine NISSAN E-PSF or equivalent (Use of a power steering fluid other than Genuine NISSAN E-PSF will prevent the power steering system from operating properly.)	L M
Brake fluid		—	—	—	Genuine NISSAN Brake Fluid or equivalent DOT 3 (US FMVSS No. 116)	N
Multi-purpose grease		—	—	—	NLGI No. 2 (Lithium soap base)	O
Windshield washer fluid		5.0 ℓ	5-1/4 qt	4-3/8 qt	Genuine NISSAN Windshield Washer Concentrate Cleaner & Antifreeze or equivalent	O
Air conditioning system refrigerant		0.80 ± 0.03 kg	1.80 ± 0.07 lb	1.80 ± 0.07 lb	HFC-134a (R-134a) (For further information, see "Air conditioning specification label".)	MA
Air conditioning system oil		230 m ℓ	7.8 fl oz	8.1 fl oz	A/C System Oil Type S (DH-PS) (For further information, see "Air conditioning specification label".)	

# RECOMMENDED FLUIDS AND LUBRICANTS

< PERIODIC MAINTENANCE >

## FOR MEXICO : Engine Coolant Mixture Ratio

INFOID:000000011131992

The engine cooling system is filled at the factory with a high-quality, year-round and extended life engine coolant. The high quality engine coolant contains the specific solutions effective for the anti-corrosion and the anti-freeze function. Therefore, additional cooling system additives are not necessary.

### Coolant Mixture Ratios

For outside temperatures down to:		Anti-freeze coolant mixture ratio	
° C	° F	Genuine NISSAN Engine Coolant or equivalent	Demineralized water or distilled water
- 15°	5°	30 %	70 %
- 35°	- 30°	50 %	50 %

### CAUTION:

- When adding or replacing coolant, be sure to use only a Genuine NISSAN Engine Coolant or equivalent in its quality with the proper mixture ratio. See the examples shown in the figure. The use of other types of engine coolant may damage the engine cooling system.
- When checking the engine coolant mixture ratio by the coolant hydrometer, use the chart below to correct your hydrometer reading (specific gravity) according to coolant temperature.

Mixed coolant specific gravity

Unit: specific gravity

Engine coolant mixture ratio	Coolant temperature °C (°F)			
	15 (59)	25 (77)	35 (95)	45 (113)
30%	1.046 - 1.050	1.042 - 1.046	1.038 - 1.042	1.033 - 1.038
50%	1.076 - 1.080	1.070 - 1.076	1.065 - 1.071	1.059 - 1.065

### WARNING:

Do not remove the radiator cap when the engine is hot. Serious burns could occur from high pressure engine coolant escaping from the radiator. Wrap a thick cloth around the cap. Slowly turn it a quarter turn to allow built-up pressure to escape. Carefully remove the cap by turning it all the way.

# ENGINE MAINTENANCE (VQ35DE)

< PERIODIC MAINTENANCE >

## ENGINE MAINTENANCE (VQ35DE)

### DRIVE BELTS

#### DRIVE BELTS : Checking Drive Belts

INFOID:0000000011131993

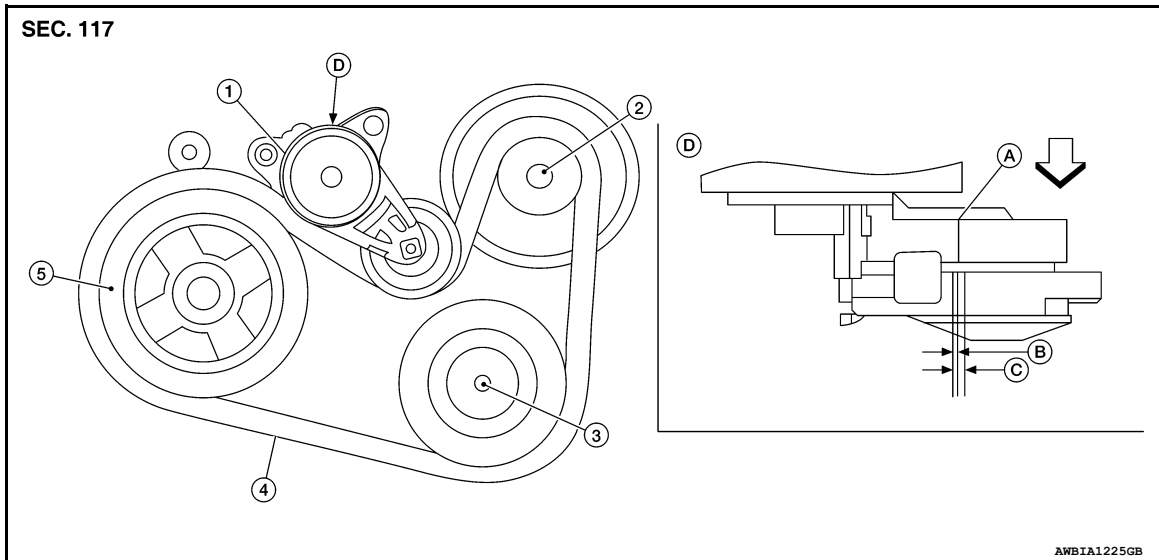

- |   |                       |                   |
|---|-----------------------|-------------------|
| 1. Drive belt auto-tensioner              | 2. Generator          | 3. A/C compressor |
| 4. Drive belt                             | 5. Crankshaft pulley  | A. Indicator      |
| B. Range when new drive belt is installed | C. Possible use range | D. View D         |
- ↶ Engine front

#### **WARNING:**

**Inspect and check the drive belt with the engine off.**

1. Visually check entire drive belt for wear, damage or cracks.
2. Check that the drive belt auto-tensioner indicator is within the possible use range.

#### **NOTE:**

- When new drive belt is installed, the drive belt auto-tensioner indicator should be within the new drive belt range.
  - Check the drive belt auto-tensioner indicator when the engine is cold.
3. If the drive belt auto-tensioner indicator is out of the possible use range or belt is damaged, replace drive belt.

#### DRIVE BELTS : Tension Adjustment

INFOID:0000000011131994

- Drive belt tension is automatically adjusted by the drive belt auto-tensioner.
- Drive belt tension is not manually adjustable.

### ENGINE COOLANT

#### ENGINE COOLANT : System Inspection

INFOID:0000000011131995

#### **WARNING:**

**Do not remove the radiator cap when the engine is hot. Serious burns could occur from high pressure engine coolant escaping from the radiator. Wrap a thick cloth around the cap. Slowly turn it a quarter turn to allow built-up pressure to escape. Carefully remove the cap by turning it all the way.**

#### CHECKING COOLING SYSTEM HOSES

Check hoses for the following:

- Improper attachment
- Leaks
- Cracks

# ENGINE MAINTENANCE (VQ35DE)

## < PERIODIC MAINTENANCE >

- Damage
- Loose connections
- Chafing
- Deterioration

### CHECKING RESERVOIR LEVEL

- Check the coolant reservoir tank level when the engine is cool.
- Adjust engine coolant level, if necessary, to ensure that the engine coolant level is within the MIN to MAX range.

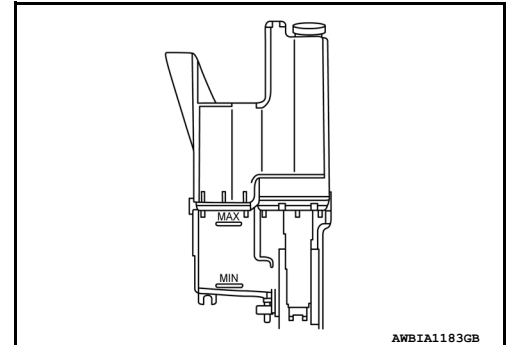

### CHECKING COOLING SYSTEM FOR LEAKS

To check for leaks, apply pressure to the cooling system using suitable tools (A and B).

Testing pressure : Refer to [CO-28, "Radiator"](#).

#### **WARNING:**

Do not remove the radiator cap when the engine is hot. Serious burns could occur from high pressure engine coolant escaping from the radiator.

#### **CAUTION:**

Higher test pressure than specified may cause radiator damage.

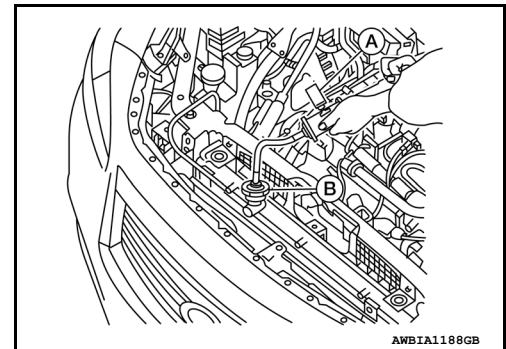

### CHECKING RADIATOR CAP

1. Inspect the radiator cap.
  - Replace the cap if the metal plunger cannot be seen around the edge of the black rubber gasket.
  - Replace the cap if deposits of waxy residue or other foreign material are on the black rubber gasket or the metal retainer.

#### **NOTE:**

Thoroughly wipe out the radiator filler neck to remove any waxy residue or foreign material.

2. Pull the negative-pressure valve to open it and check that it closes completely when released.
  - Check that there is no dirt or damage on the valve seat of the radiator cap negative-pressure valve.
  - Check that there are no abnormalities in the opening and closing conditions of the negative-pressure valve.

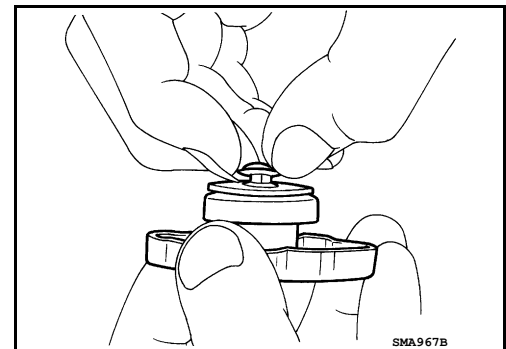

# ENGINE MAINTENANCE (VQ35DE)

## < PERIODIC MAINTENANCE >

3. Check radiator cap relief pressure using suitable tools (A and B).

**Standard** : Refer to [CO-28, "Radiator"](#).

- Apply water or engine coolant to the cap seal surface before connecting the radiator cap to the tester,
- Replace the radiator cap if there is an abnormality in the negative-pressure valve, or if the open-valve pressure is outside of the standard values.

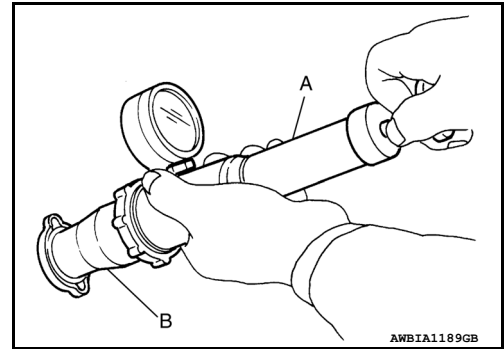

## CHECKING RADIATOR

Check radiator for mud or clogging. If necessary, clean radiator as follows.

### CAUTION:

- **Be careful not to bend or damage the radiator fins.**
- **When radiator is cleaned on-vehicle, remove surrounding parts in order to access the radiator core. Tape the harness and harness connectors to prevent water from entering.**

1. Spray water to the back side of the radiator core using a side to side motion from the top down.
2. Stop spraying when debris no longer flows from radiator core.
3. Blow air into the back side of radiator core using a side to side motion from the top down.
  - Use compressed air lower than 490 kPa (5.00 kg/cm<sup>2</sup>, 71.1 psi) and keep distance more than 30 cm (11.8 in).
4. Continue to blow air until no water sprays out.
5. Check for engine coolant leaks. Repair as necessary.

## ENGINE COOLANT : Changing Engine Coolant

INFOID:000000011131996

### WARNING:

**Do not remove the radiator cap when the engine is hot. Serious burns could occur from high pressure engine coolant escaping from the radiator. Wrap a thick cloth around the cap. Slowly turn it a quarter turn to allow built-up pressure to escape. Carefully remove the cap by turning it all the way.**

## DRAINING ENGINE COOLANT

1. Open radiator drain plug (1) at the bottom of radiator and remove the radiator filler cap.

### CAUTION:

**Do not allow the engine coolant to contact the drive belt.**

← : Front

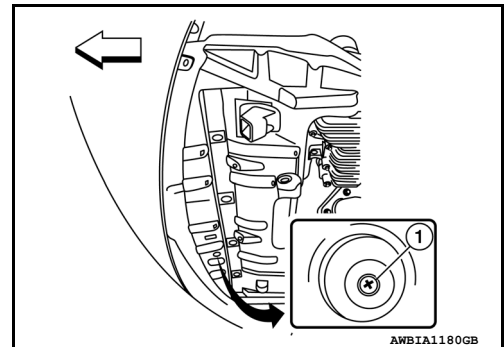

2. Remove water drain plug (A) and copper sealing washer (B).

### CAUTION:

**Do not reuse copper sealing washers.**

← : Front

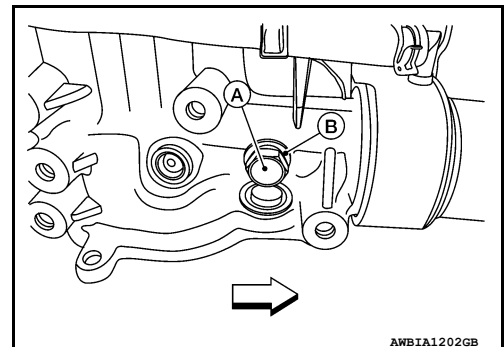

## ENGINE MAINTENANCE (VQ35DE)

### < PERIODIC MAINTENANCE >

3. For a complete cooling system drain, remove the reservoir tank and drain the engine coolant, and then clean the reservoir tank before installation.

**CAUTION:**

**Do not allow the engine coolant to contact the drive belt.**

4. When performing a complete cooling system drain, remove the water drain plug (B), connector bolt (C), and copper sealing washer (A) on the cylinder block.

**CAUTION:**

**Do not reuse copper sealing washers.**

**NOTE:**

- For Canada, water drain plug (B) is a block heater, not a drain plug.
- Remove water drain plug (D) and copper sealing washer (E) during engine overhaul.

**CAUTION:**

**Do not reuse copper sealing washers.**

⇐ : Front

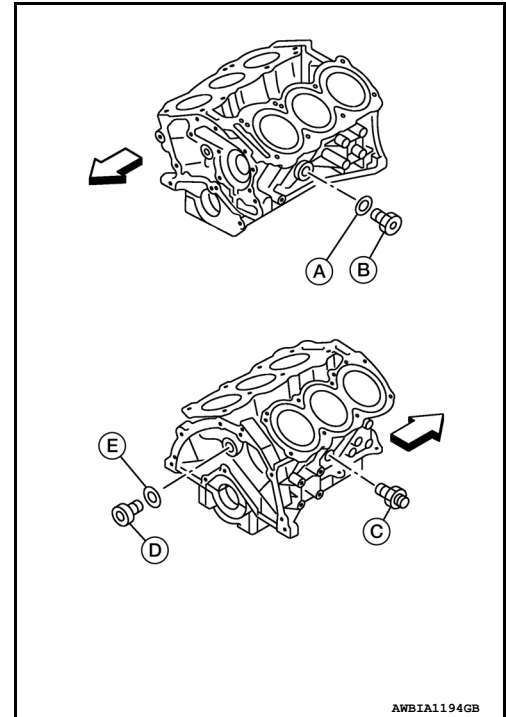

5. Check the drained engine coolant for contaminants such as rust, corrosion or discoloration.
  - If contaminated, flush the engine cooling system. Refer to FLUSHING COOLING SYSTEM.

### REFILLING ENGINE COOLANT

1. Install the radiator drain plug and the reservoir tank, (if removed).
2. Install the water drain plug (A) and copper sealing washer (B). Tighten water drain plug to specification.

**CAUTION:**

**Do not reuse copper sealing washers.**

⇐ : Front

**Water drain plug (A) : 12.25 N·m (1.2 kg-m, 9.0 ft-lb)**

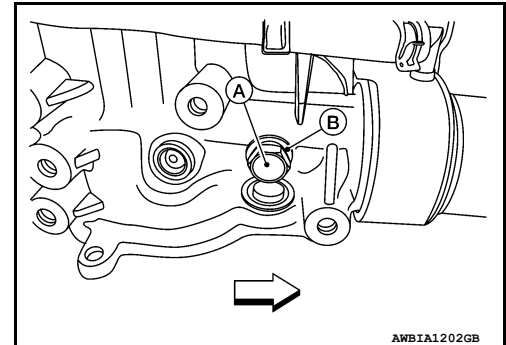

## ENGINE MAINTENANCE (VQ35DE)

### < PERIODIC MAINTENANCE >

3. Install the cylinder block drain plugs (if removed).
  - Apply sealant to the thread of the water drain plug (B), connector bolt (C) and water drain plug (D), (if removed).

**CAUTION:**

**Do not reuse copper sealing washers.**

← : Front

**NOTE:**

- For Canada, water drain plug (B) in is a block heater, not a water drain plug.
- Install copper sealing washers (E) and (A), (if removed).
- Use Genuine High Performance Thread Sealant or equivalent. Refer to [GI-22, "Recommended Chemical Products and Sealants"](#).
- Tighten each plug and connector bolt to specifications.

**Water drain plug (B) : 62.0 N·m (6.3 kg-m, 46 ft-lb)**

**Connector Bolt (C) : 27.0 N·m (2.8 kg-m, 20 ft-lb)**

**Water drain plug (D) : 78.0 N·m (8.0 kg-m, 58 ft-lb)**

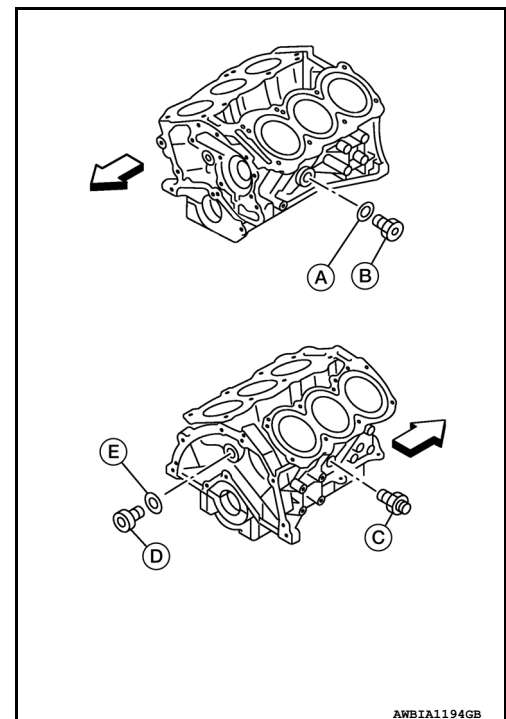

4. If disconnected, reattach the upper radiator hose at the engine side.
5. Set the vehicle heater controls to the full HOT and heater ON position. Turn the vehicle ignition ON with the engine OFF as necessary to activate the heater mode.
6. Install the Tool by installing the radiator cap adapter onto the radiator neck opening. Then attach the gauge body assembly with the refill tube and the Venturi assembly to the radiator cap adapter.

**Tool number : KV991J0070 (J-45695)**

7. Insert the refill hose into the engine coolant mixture container that is placed at floor level. Make sure the ball valve is in the closed position.
  - **Use the specified engine coolant or equivalent. Refer to [MA-15, "FOR USA AND CANADA : Fluids and Lubricants"](#) (United States and Canada) or [MA-16, "FOR MEXICO : Fluids and Lubricants"](#) (Mexico).**

**Engine Coolant capacity (with reservoir tank) : Refer to [MA-15, "FOR USA AND CANADA : Fluids and Lubricants"](#) (United States and Canada) or [MA-16, "FOR MEXICO : Fluids and Lubricants"](#) (Mexico).**

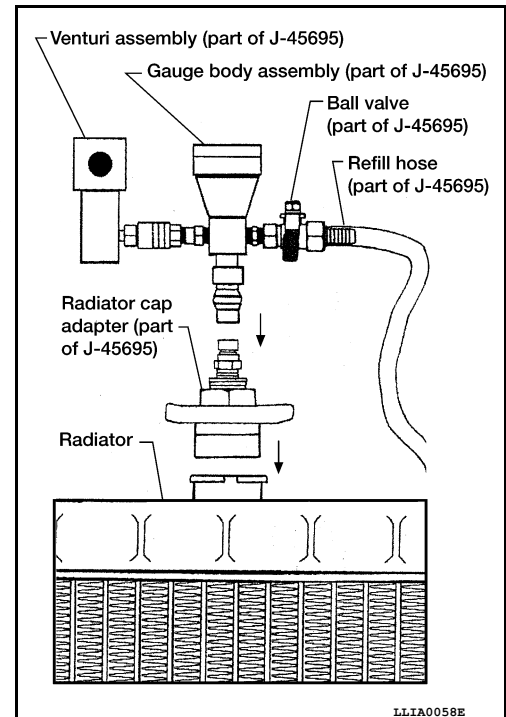

8. Install an air hose to the Venturi assembly. The air pressure must be within specification.

**Compressed air supply pressure : 549 - 824 kPa (5.6 - 8.4 kg/cm<sup>2</sup>, 80 - 119 psi)**

**CAUTION:**

**The compressed air supply must be equipped with an air dryer.**

9. The vacuum gauge will begin to rise and there will be an audible hissing noise. During this process open the ball valve on the refill hose slightly. Rising engine coolant will be visible in the refill hose. After the refill hose is full of engine coolant, close the ball valve. This will purge air trapped in the refill hose.

# ENGINE MAINTENANCE (VQ35DE)

## < PERIODIC MAINTENANCE >

10. Continue to draw the vacuum until the gauge reaches 28 inches of vacuum. The gauge may not reach 28 inches in high altitude locations. Refer to the following table for expected vacuum readings.

Altitude above sea level	Vacuum gauge reading
0 - 100 m (328 ft)	: 28 inches of vacuum
300 m (984 ft)	: 27 inches of vacuum
500 m (1,641 ft)	: 26 inches of vacuum
1,000 m (3,281 ft)	: 24 - 25 inches of vacuum

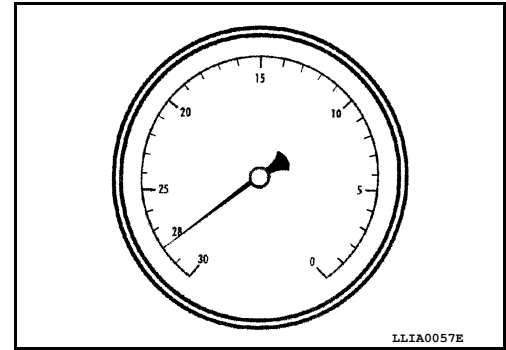

11. When the vacuum gauge has reached the specified amount, disconnect the air hose and wait 20 seconds to see if the system loses vacuum. If the vacuum level drops, perform necessary repairs to the system and repeat steps 6 - 8 to bring the vacuum to the specified amount. Recheck for leaks.
12. Place the engine coolant container (with the refill hose inserted) at the same level as the top of the radiator. Then open the ball valve on the refill hose so the engine coolant will be drawn up to fill the cooling system. The cooling system is full when the vacuum gauge reads zero.

### CAUTION:

**Do not allow the engine coolant container to get too low when filling to prevent air from being inadvertently drawn into the cooling system.**

13. Remove the Tool from the radiator neck opening and install the radiator cap.
14. Fill the cooling system reservoir tank to the specified level. Run the engine to warm up the cooling system and top up the system as necessary.

## FLUSHING COOLING SYSTEM

1. Fill the radiator from the filler neck above the radiator upper hose and reservoir tank with clean water and reinstall radiator filler cap.
2. Run the engine until it is at normal operating temperature.
3. Rev the engine two or three times under no-load.
4. Stop the engine and wait until it cools down.
5. Drain the water from the system. Refer to [MA-21, "ENGINE COOLANT : Changing Engine Coolant"](#).
6. Repeat steps 1 through 5 until clear water begins to drain from the radiator.

## FUEL LINES

### FUEL LINES : Inspection

INFOID:000000011131997

Inspect fuel lines, filler cap and tank for improper attachment, leaks, cracks, damage, loose connections, chafing or deterioration. Repair or replace damaged parts as necessary.

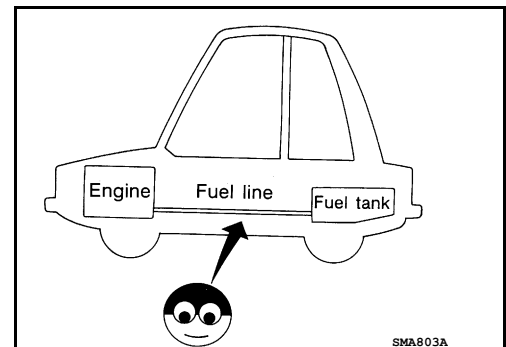

## AIR CLEANER FILTER





# ENGINE MAINTENANCE (VQ35DE)

## < PERIODIC MAINTENANCE >

- Before starting the engine, check the oil level. If the engine is already started, stop it and allow 10 minutes before checking.
- Check that the oil level is within the range as indicated on the dipstick.
- If it is out of range, add oil as necessary until the dipstick indicates the correct level.

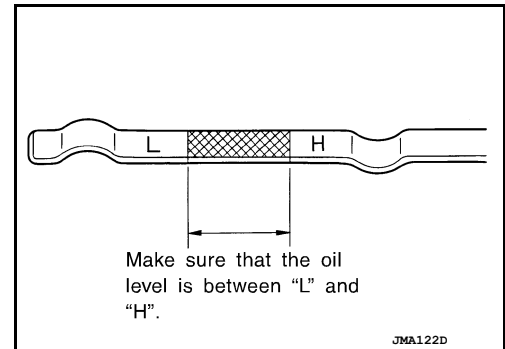

## ENGINE OIL : Changing Engine Oil

INFOID:000000011132001

### WARNING:

- **Be careful not to burn yourself, as the engine oil may be hot.**
  - **Prolonged and repeated contact with used engine oil may cause skin cancer; try to avoid direct skin contact with used engine oil. If skin contact is made, wash thoroughly with soap or hand cleaner as soon as possible.**
1. Position the vehicle so it is level on the hoist.
  2. Warm up the engine and check for engine oil leaks.
  3. Stop engine and wait for 10 minutes.
  4. Remove the oil pan drain plug and oil filler cap.
  5. Drain the engine oil.
  6. Install the oil pan drain plug with a new washer and refill the engine with new engine oil.

**Oil specification and viscosity** : For North America, refer to [MA-16, "FOR USA AND CANADA : Engine Oil Recommendation"](#). For Mexico, refer to [MA-16, "FOR MEXICO : Fluids and Lubricants"](#).

**Oil pan drain plug** : 34.3 N·m (3.5 kg·m, 25 ft·lb)

### CAUTION:

- **Be sure to clean the oil pan drain plug and install with a new washer.**
  - **The refill capacity depends on the engine oil temperature and drain time. Use the specifications for reference only. Always use the dipstick to determine when the proper amount of engine oil is in the engine.**
7. Warm up the engine and check around the oil pan drain plug and oil filter for oil leaks.
  8. Stop engine and wait for 10 minutes.
  9. Check the engine oil level using the dipstick.

### CAUTION:

**Do not overfill the engine with engine oil.**

## OIL FILTER

### OIL FILTER : Removal and Installation

INFOID:000000011132002

#### REMOVAL

1. Drain engine oil. Refer to [LU-9, "Changing Engine Oil"](#).
2. Remove front fender protector side cover RH. Refer to [EXT-28, "FENDER PROTECTOR : Exploded View"](#).

# ENGINE MAINTENANCE (VQ35DE)

## < PERIODIC MAINTENANCE >

3. Remove the oil filter using Tool (A) as shown.

**Tool number** : KV10115801 (J-38956)

**WARNING:**

Be careful not to burn yourself, as the engine oil may be hot.

**CAUTION:**

- When removing, prepare a shop cloth to absorb any oil leaks or spills.
- Do not allow engine oil to adhere to the drive belts.
- Completely wipe off any oil that adheres to the engine and the vehicle.

- The oil filter is provided with a relief valve. Use a genuine NISSAN oil filter or equivalent.

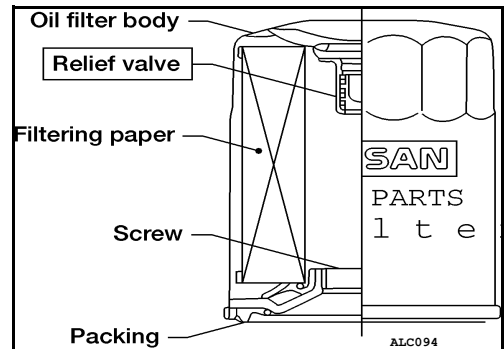
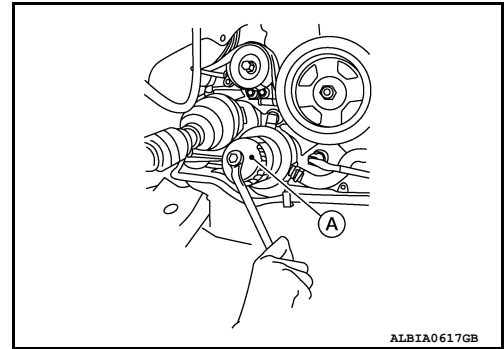

## INSTALLATION

1. Remove foreign materials adhering to the oil filter installation surface.
2. Apply clean engine oil to the oil seal contact surface of the new oil filter.

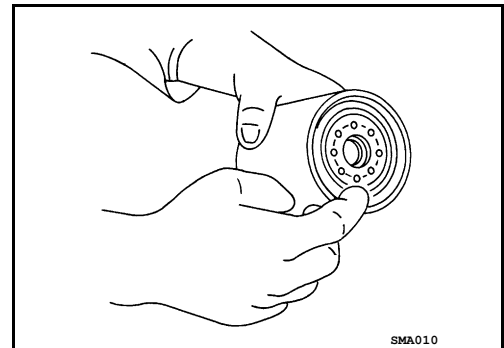

3. Screw the oil filter manually until it touches the installation surface, then tighten it by turning another 2/3 turn or tighten to specification using Tool.

**Oil filter** : 18.0 N·m (1.8 kg-m, 13 ft-lb)

**Tool number** : KV10115801 (J-38956)

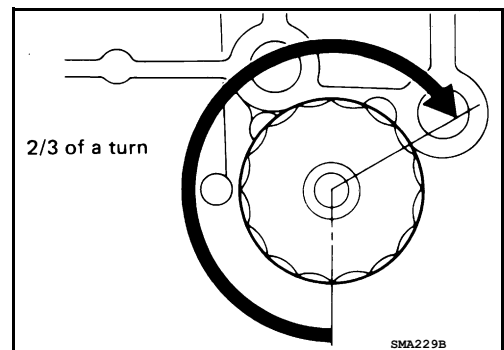

4. Refill the engine with new engine oil. Refer to [LU-9. "Changing Engine Oil"](#).
5. Check the oil level and add engine oil as necessary. Refer to [LU-8. "Inspection"](#).
6. After warming up the engine, check for engine oil leaks.
7. Install front fender protector side cover RH. Refer to [EXT-28. "FENDER PROTECTOR : Exploded View"](#).

## SPARK PLUG

A  
B  
C  
D  
E  
F  
G  
H  
I  
J  
K  
L  
M  
N  
O

MA

# ENGINE MAINTENANCE (VQ35DE)

< PERIODIC MAINTENANCE >

## SPARK PLUG : Exploded View

INFOID:000000011132003

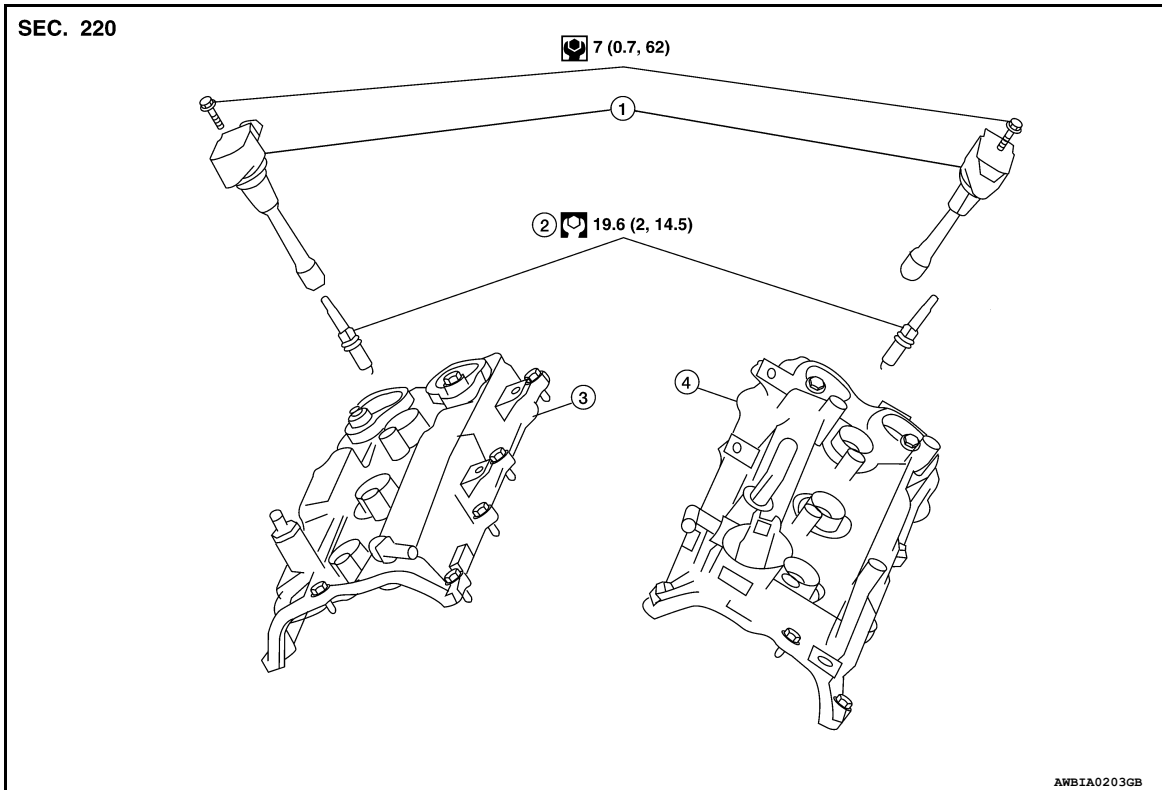

1. Ignition coil

2. Spark plug

3. Rocker cover RH

4. Rocker cover LH

## SPARK PLUG : Removal and Installation

INFOID:000000011132004

### REMOVAL

1. Remove the ignition coil. Refer to [EM-42. "Removal and Installation LH"](#) and [EM-42. "Removal and Installation RH"](#).
2. Remove the spark plug with a suitable spark plug wrench.

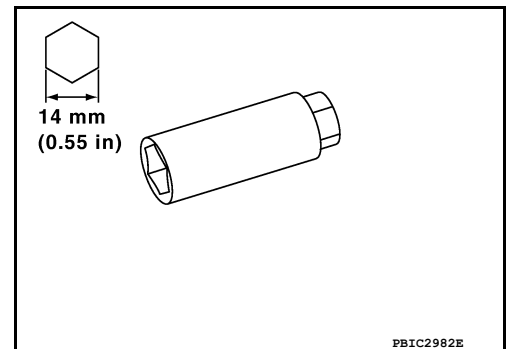

### INSPECTION AFTER REMOVAL

# ENGINE MAINTENANCE (VQ35DE)

## < PERIODIC MAINTENANCE >

Use the standard type spark plug for normal condition.

**Spark plug** : Refer to [EM-135, "Spark Plug"](#).

### CAUTION:

- Do not drop or shock spark plug.
- Do not use a wire brush for cleaning.
- If plug is covered with carbon, a spark plug cleaner may be used.

**Cleaner air pressure** : less than 588 kPa (6 kg/cm<sup>2</sup>, 85 psi)

**Cleaning time** : less than 20 seconds

- Spark plug gap adjustment is not required between replacement intervals.
- Measure spark plug gap. When it exceeds the limit, replace spark plug even if it is within the specified replacement mileage. Refer to [EM-135, "Spark Plug"](#).

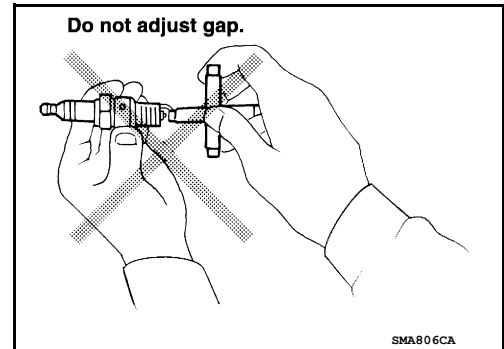
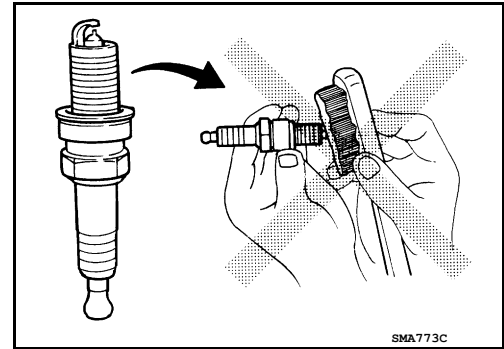

## INSTALLATION

Installation is in the reverse order of removal.

Make	DENSO
Standard type*	FXE22HR11
Gap (nominal)	1.1 mm (0.043 in)

\*: Always check with the Parts Department for the latest parts information.

## EVAP VAPOR LINES

### EVAP VAPOR LINES : Inspection

INFOID:000000011132005

1. Visually inspect EVAP vapor lines for improper attachment and for cracks, damage, loose connections, chafing and deterioration.
2. Inspect fuel tank filler cap vacuum relief valve for clogging, sticking, etc.

# CHASSIS AND BODY MAINTENANCE

< PERIODIC MAINTENANCE >

## CHASSIS AND BODY MAINTENANCE

### IN-CABIN MICROFILTER

#### IN-CABIN MICROFILTER : Removal and Installation

INFOID:000000011132006

##### REMOVAL

1. Remove center console side finisher (RH). Refer to [IP-18. "Exploded View"](#).
2. Release the in-cabin microfilter cover tab (A) and remove the cover from under the RH side of the instrument panel.

**CAUTION:**

Use care when lifting up on the tab to avoid damaging it.

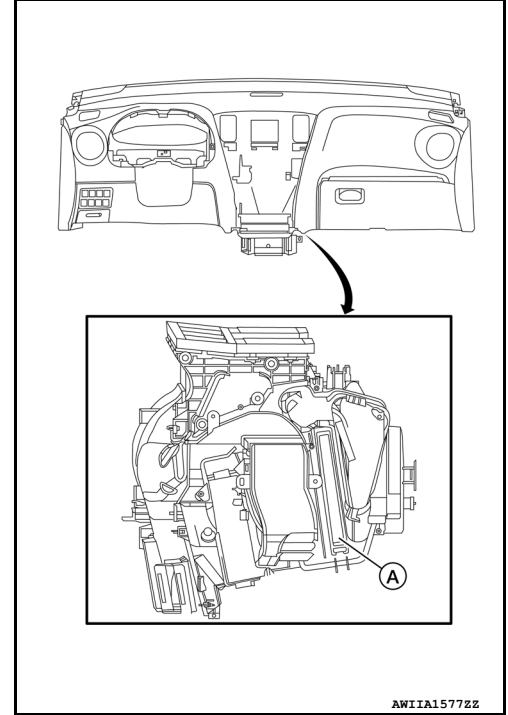

3. Remove the in-cabin microfilter.

**CAUTION:**

If the filter is deformed/damaged when removing, replace it with a new one. A deformed or damaged filter may affect the dust collecting performance.

##### INSTALLATION

Installation is in the reverse order of removal.

**CAUTION:**

When installing, handle the filter with extreme care to avoid deforming or damaging the filter.

**NOTE:**

The in-cabin microfilter is marked with an air flow arrow. The end of the microfilter with the arrow should face the passenger side of the vehicle. The arrow should point towards the rear of the vehicle.

### EXHAUST SYSTEM

#### EXHAUST SYSTEM : Inspection

INFOID:000000011132007

Check exhaust pipes, muffler and mounting for improper attachment, leaks, cracks, damage or deterioration. Repair or replace as necessary.

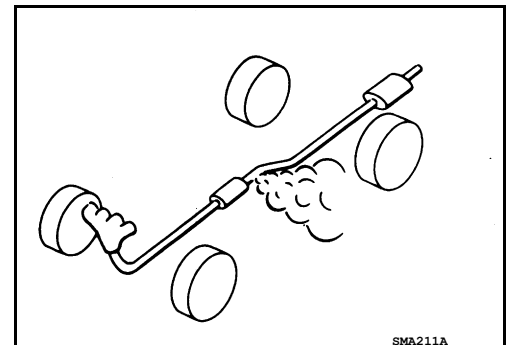

### CVT FLUID

# CHASSIS AND BODY MAINTENANCE

< PERIODIC MAINTENANCE >

## CVT FLUID : Inspection

INFOID:000000011132008

### FLUID LEAKAGE

- Check transaxle surrounding area (oil seal and plug etc.)for fluid leakage.
- If anything is found, repair or replace damaged parts and adjust CVT fluid level. Refer to [TM-188, "Adjustment"](#) (RE0F10E) or [TM-400, "Adjustment"](#) (RE0F10J).

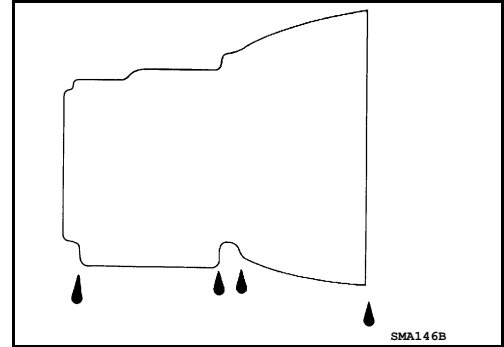

## CVT FLUID : Changing

INFOID:000000011132009

- |                       |  |
|-----------------------|--|
| <b>CVT fluid</b>      | : Refer to <a href="#">TM-222, "General Specification"</a> (RE0F10E) or <a href="#">TM-434, "General Specification"</a> (RE0F10J). |
| <b>Fluid capacity</b> | : Refer to <a href="#">TM-222, "General Specification"</a> (RE0F10E) or <a href="#">TM-434, "General Specification"</a> (RE0F10J). |

### CAUTION:

- Always use shop paper. Never use shop cloth.
  - Replace a drain plug gasket with new ones at the final stage of the operation when installing.
  - Use caution when looking into the drain hole as there is a risk of dripping fluid entering the eye.
  - After replacement, always perform CVT fluid leakage check.
1. Select "Data Monitor" in "TRANSMISSION" using CONSULT.
  2. Select "FLUID TEMP" and confirm that the CVT fluid temperature is 40°C (104°F) or less.
  3. Check that the selector lever is in the "P" position, then completely engage the parking brake.
  4. Lift up the vehicle.
  5. Remove the drain plug and drain the CVT fluid from the oil pan. Refer to [TM-199, "Exploded View"](#) (RE0F10E) or [TM-411, "Exploded View"](#) (RE0F10J).
  6. Install the drain plug to oil pan.  
**CAUTION:**  
**Drain plug gasket use the old one.**
  7. Remove the overflow plug ① from converter housing.

← : Vehicle front

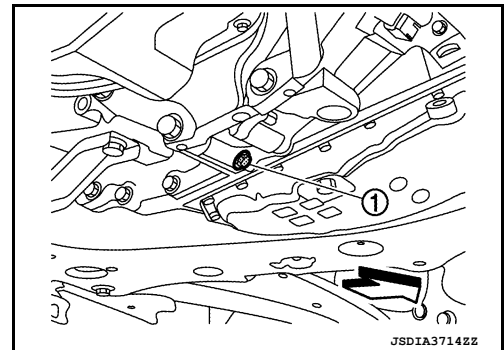

A  
B  
C  
D  
E  
F  
G  
H  
I  
J  
K  
L  
M  
N  
O  
MA

## CHASSIS AND BODY MAINTENANCE

### < PERIODIC MAINTENANCE >

8. Install the charging pipe set (KV311039S0) (A) into the overflow plug hole.

**CAUTION:**

**Tighten the charging pipe by hand.**

9. Install the ATF changer hose (B) to the charging pipe.

**CAUTION:**

**Press the ATF changer hose all the way onto the charging pipe until it stops.**

10. Fill approximately 3 liter (3-1/8 US qt, 2-5/8 Imp qt) of the CVT fluid.

11. Remove the ATF changer hose and charging pipe, then install the overflow plug.

**NOTE:**

Perform this work quickly because CVT fluid leaks.

12. Lift down the vehicle.

13. Start the engine.

14. While depressing the brake pedal, shift the selector lever to the entire position from "P" to "L", and shift it to the "P" position.

**NOTE:**

Hold the lever at each position for 5 seconds.

15. Check that the CONSULT "Data Monitor" in "FLUID TEMP" is 35°C (95°F) to 45°C (113°F).

16. Stop the engine.

17. Lift up the vehicle.

18. Remove the drain plug, and then drain CVT fluid from oil pan.

19. Repeat steps 8 to 18 (one time).

20. Tighten the drain plug to the specified torque. Refer to [TM-199, "Exploded View"](#) (RE0F10E) or [TM-411, "Exploded View"](#) (RE0F10J).

21. Remove the overflow plug.

22. Install the charging pipe set (KV311039S0) into the overflow plug hole.

**CAUTION:**

**Tighten the charging pipe by hand.**

23. Install the ATF changer hose to the charging pipe.

**CAUTION:**

**Press the ATF changer hose all the way onto the charging pipe until it stops.**

24. Fill approximately 3 liter (3-1/8 US qt, 2-5/8 Imp qt) of the CVT fluid.

25. Remove the ATF changer hose and charging pipe, then install the overflow plug.

**NOTE:**

Perform this work quickly because CVT fluid leaks.

26. Lift down the vehicle.

27. Start the engine.

28. While depressing the brake pedal, shift the selector lever to the entire position from "P" to "L", and shift it to the "P" position.

**NOTE:**

Hold the lever at each position for 5 seconds.

29. Check that the CONSULT "Data Monitor" in "FLUID TEMP" is 35°C (95°F) to 45°C (113°F).

30. Lift up the vehicle.

31. Remove the overflow plug and confirm that the CVT fluid is drained from the overflow plug hole.

**CAUTION:**

**Perform this work with the vehicle idling.**

**NOTE:**

If the CVT fluid is not drained, refer to "Adjustment" and refill with the CVT fluid.

32. When the flow of CVT fluid slows to a drip, tighten the overflow plug to the specified torque. Refer to [TM-199, "Exploded View"](#) (RE0F10E) or [TM-411, "Exploded View"](#) (RE0F10J).

**CAUTION:**

**Never reuse O-ring.**

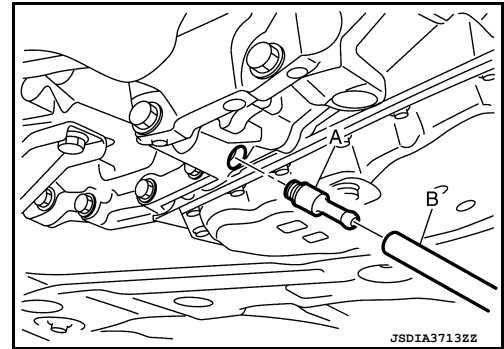



# CHASSIS AND BODY MAINTENANCE

## < PERIODIC MAINTENANCE >

33. Lift down the vehicle.
34. Select "Data Monitor" in "TRANSMISSION" using CONSULT.
35. Select "CONFORM CVTF DETERIORATION".
36. Select "Erase".
37. Stop the engine.

## TRANSFER OIL

### TRANSFER OIL : Inspection

INFOID:000000011132010

#### TRANSFER OIL LEAKS

Check that transfer oil is not leaking from transfer assembly or around it.

#### TRANSFER OIL LEVEL

##### **CAUTION:**

**Do not start engine while checking transfer oil level.**

1. Remove filler plug (1) and gasket.

← : Front

2. Transfer oil level (A) should be level with bottom of filler plug hole. Add transfer oil if necessary. Refer to [MA-15, "FOR USA AND CANADA : Fluids and Lubricants"](#) (USA and CANADA) or [MA-16, "FOR MEXICO : Fluids and Lubricants"](#) (MEXICO).
3. Set a new gasket onto filler plug, and install it in the transfer and tighten to specified torque. Refer to [DLN-88, "Exploded View"](#).

##### **CAUTION:**

**Do not reuse gasket.**

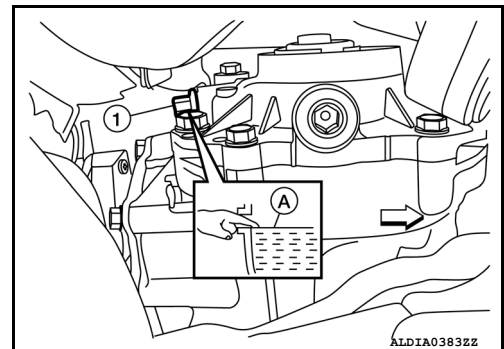

### TRANSFER OIL : Draining

INFOID:000000011132011

##### **CAUTION:**

**Do not start engine while working.**

1. Run the vehicle to warm up the transfer unit sufficiently.
2. Stop the engine and remove drain plug (1) and gasket and drain the transfer oil.

← : Front

3. Set a new gasket onto filler plug, and install it in the transfer and tighten to specified torque. Refer to [DLN-88, "Exploded View"](#).

##### **CAUTION:**

**Do not reuse gasket.**

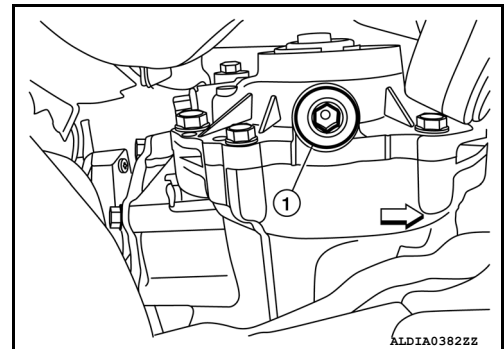

### TRANSFER OIL : Refilling

INFOID:000000011132012

##### **CAUTION:**

**Do not start engine while checking transfer oil level.**

A  
B  
C  
D  
E  
F  
G  
H  
I  
J  
K  
L  
M  
N  
O

MA

# CHASSIS AND BODY MAINTENANCE

## < PERIODIC MAINTENANCE >

1. Remove filler plug (1).
2. Fill with new transfer oil to the specified level near the filler plug hole.

⇐ : Front

**Transfer oil grade and viscosity**

: Refer to [MA-15, "FOR USA AND CANADA : Fluids and Lubricants"](#) (USA and CANADA) or [MA-16, "FOR MEXICO : Fluids and Lubricants"](#) (MEXICO).

**Transfer oil capacity**

: Refer to [DLN-92, "General Specifications"](#).

3. Set a new gasket onto filler plug, and install it in the transfer and tighten to specified torque. Refer to [DLN-88, "Exploded View"](#).

**CAUTION:**

Do not reuse gasket.

## REAR DIFFERENTIAL GEAR OIL

### REAR DIFFERENTIAL GEAR OIL : Inspection

INFOID:000000011132013

#### REAR DIFFERENTIAL GEAR OIL LEAKS

Check that rear differential gear oil is not leaking from final drive assembly or around it.

#### REAR DIFFERENTIAL GEAR OIL LEVEL

**CAUTION:**

Do not start engine while checking rear differential gear oil level.

1. Remove and discard filler plug (1).

**CAUTION:**

Do not reuse filler plug.

⇐ : Front

2. Rear differential gear oil level should be level with the bottom of filler plug hole. Add rear differential gear oil if necessary. Refer to [MA-15, "FOR USA AND CANADA : Fluids and Lubricants"](#) (USA and CANADA) or [MA-16, "FOR MEXICO : Fluids and Lubricants"](#) (MEXICO).

3. Install filler plug (1) and tighten to specified torque. Refer to [DLN-125, "Exploded View"](#).

### REAR DIFFERENTIAL GEAR OIL : Draining

INFOID:000000011132014

**CAUTION:**

Do not start engine while checking rear differential gear oil level.

1. Remove and discard drain plug (1), and drain rear differential gear oil.

**CAUTION:**

Do not reuse drain plug.

⇐ : Front

2. Install drain plug (1) and tighten to specified torque. Refer to [DLN-125, "Exploded View"](#).

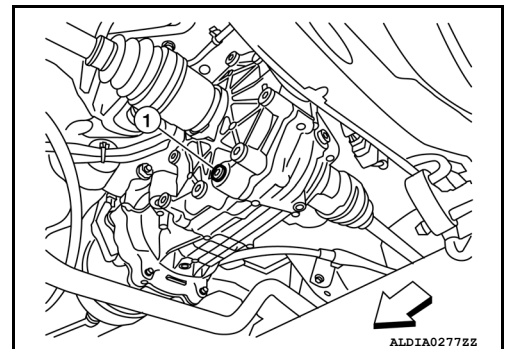
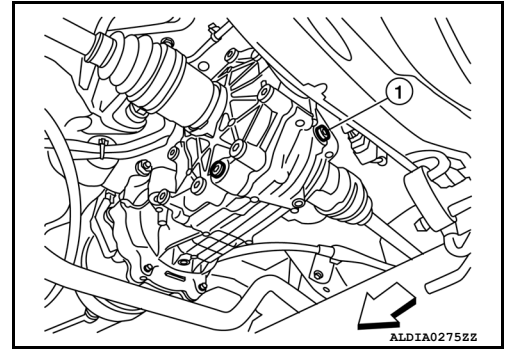
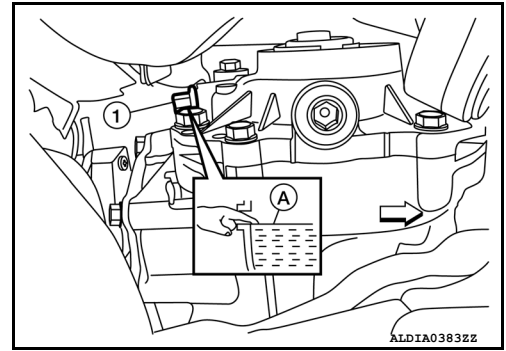

# CHASSIS AND BODY MAINTENANCE

< PERIODIC MAINTENANCE >

## REAR DIFFERENTIAL GEAR OIL : Refilling

INFOID:000000011132015

### CAUTION:

Do not start engine while checking rear differential gear oil level.

1. Remove and discard filler plug (1).

### CAUTION:

Do not reuse filler plug.

← : Front

2. Fill with new rear differential gear oil to the specified level near the filler plug hole.

**Rear differential gear oil grade and viscosity**

: Refer to [MA-15, "FOR USA AND CANADA : Fluids and Lubricants"](#) (USA and CANADA) or [MA-16, "FOR MEXICO : Fluids and Lubricants"](#) (MEXICO).

**Rear differential gear oil capacity**

: Refer to [DLN-130, "General Specification"](#).

3. Install filler plug (1) and tighten to specified torque. Refer to [DLN-125, "Exploded View"](#).

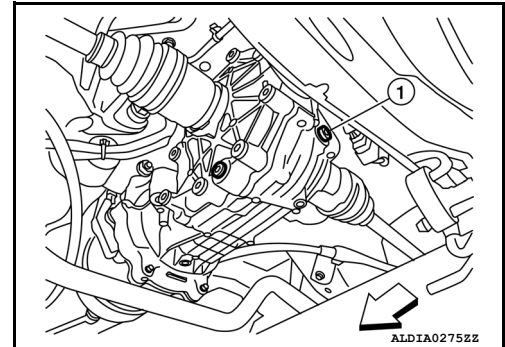

## PROPELLER SHAFT

### PROPELLER SHAFT : Inspection

INFOID:000000011132016

#### APPEARANCE AND NOISE INSPECTION

- Inspect the propeller shaft tube for dents or cracks. If damaged, replace the propeller shaft assembly.
- Check bearings for noise or damage. If damaged, replace as necessary.

#### PROPELLER SHAFT VIBRATION

##### NOTE:

If vibration is present at high speed, check propeller shaft runout first, then check mounting between propeller shaft and companion flange.

1. Measure the runout of the propeller shaft tube at several points by rotating the final drive companion flange with your hands.

**Propeller shaft runout**

: Refer to [DLN-101, "Propeller Shaft Runout"](#).

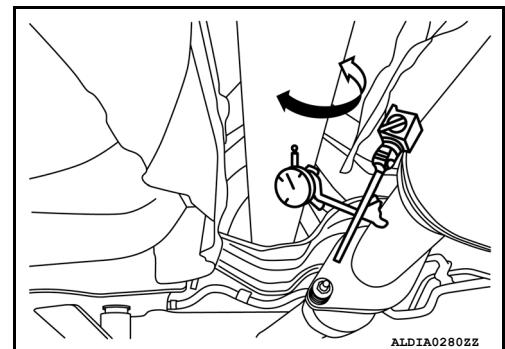

# CHASSIS AND BODY MAINTENANCE

## < PERIODIC MAINTENANCE >

- Propeller shaft runout measuring point (Point “△”).

**Dimension (A)** : 612.0 mm (24.09 in)  
**Dimension (B)** : 474.5 mm (18.68 in)

← : Front

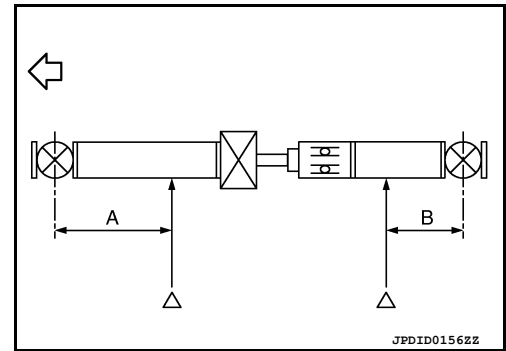

2. If the runout still exceeds specifications, disconnect the propeller shaft at the final drive companion flange; then rotate the companion flange 90°, 180°, 270° and reconnect propeller shaft.
3. Check the runout again. If the runout still exceeds specifications, replace the propeller shaft assembly.
4. After installation, check for vibration by driving the vehicle.

## WHEELS

### WHEELS : Inspection

INFOID:000000011132017

1. Check tires for wear and improper inflation.
2. Check wheels for deformation, cracks and other damage. If deformed, remove wheel and check wheel runout.
3. Remove tire from wheel and mount wheel on a tire balance machine.

#### **CAUTION:**

**DO NOT use center hole cone-type clamping machines to hold the wheel assembly during tire removal/installation or balancing or damage to the wheel paint, cladding or chrome may result. Use only rim-type or universal lug-type clamping machines to hold the wheel assembly during servicing.**

- a. Set dial indicator as shown.
- b. Check runout, if the lateral runout (A) or radial runout (B) exceeds the limit, replace wheel.

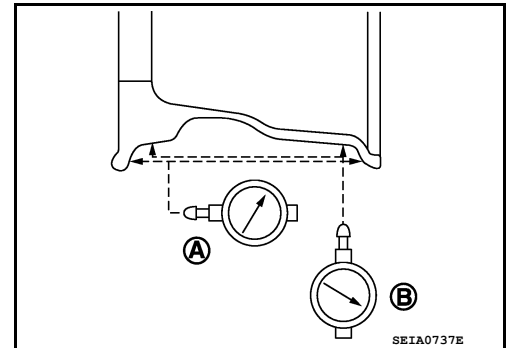

**Lateral runout (A)** Refer to [WT-61, "Road Wheel"](#)

**Radial runout (B)** Refer to [WT-61, "Road Wheel"](#)

### WHEELS : Adjustment

INFOID:000000011132018

### BALANCING WHEELS (ADHESIVE WEIGHT TYPE)

#### Preparation Before Adjustment

Remove inner and outer balance weights from the road wheel. Using releasing agent, remove double-faced adhesive tape from the road wheel.

#### **CAUTION:**

- **Be careful not to scratch the road wheel during removal.**
- **After removing double-faced adhesive tape, wipe clean all traces of releasing agent from the road wheel.**

#### Wheel Balance Adjustment

- If a balancer machine has an adhesive weight mode setting, select the adhesive weight mode setting and skip Step 2 below. If a balancer machine only has the clip-on (rim flange) weight mode setting, follow Step 2 to calculate the correct size adhesive weight.
1. Set road wheel on balancer machine using the center hole as a guide. Start the balancer machine.

# CHASSIS AND BODY MAINTENANCE

## < PERIODIC MAINTENANCE >

2. For balancer machines that only have a clip-on (rim flange) weight mode setting, follow this step to calculate the correct size adhesive weight to use. When inner and outer imbalance values are shown on the balancer machine indicator, multiply outer imbalance value by 5/3 (1.67) to determine balance weight that should be used. Select the outer balance weight with a value closest to the calculated value above and install in to the designated outer position of or at the designated angle in relation to the road wheel.

- a. Indicated imbalance value  $\times 5/3 =$  balance weight to be installed  
**Calculation example:**  
 $23 \text{ g (0.81 oz)} \times 5/3 (1.67) = 38.33 \text{ g (1.35 oz)} \Rightarrow 40 \text{ g (1.41 oz)}$   
 balance weight (closer to calculated balance weight value)

**NOTE:**

Note that balance weight value must be closer to the calculated balance weight value.

**Example:**

37.4  $\Rightarrow$  35 g (1.23 oz)

37.5  $\Rightarrow$  40 g (1.41 oz)

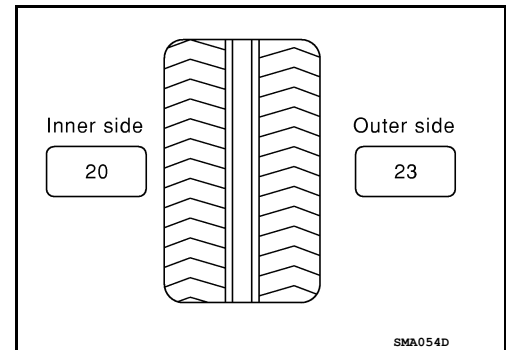

3. Install balance weight in the position shown.

**CAUTION:**

- Do not install the inner balance weight before installing the outer balance weight.
- Before installing the balance weight, be sure to clean the mating surface of the road wheel.
- When installing balance weight (1) to road wheel, set it into the grooved area (A) on the inner wall of the road wheel as shown so that the balance weight center (B) is aligned with the balancer machine indication position (angle) (C).

**CAUTION:**

- Always use genuine NISSAN adhesive balance weights.
- Balance weights are non-reusable; always replace with new ones.
- Do not install more than three sheets of balance weights.

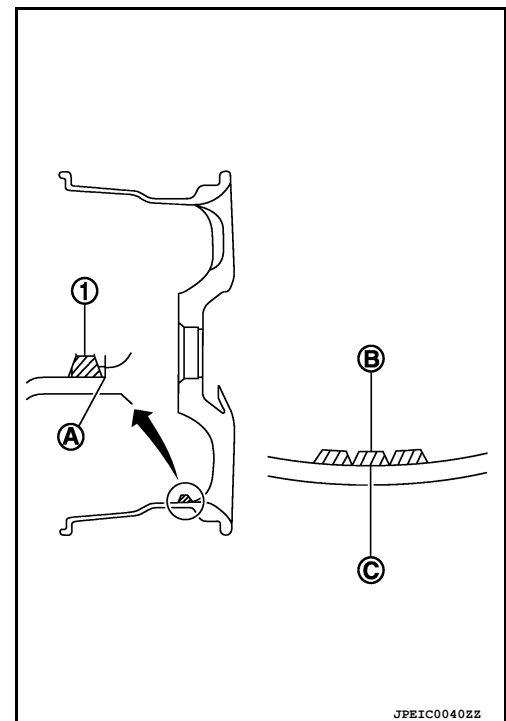

4. If calculated balance weight value exceeds 50 g (1.76 oz), install two balance weight sheets in line with each other as shown.

**CAUTION:**

Do not install one balance weight sheet on top of another.

5. Start balancer machine again.
6. Install balance weight on inner side of road wheel in the balancer machine indication position (angle).

**CAUTION:**

Do not install more than two balance weights.

7. Start balancer machine. Make sure that inner and outer residual imbalance values are 5 g (0.17 oz) each or below.

8. If either residual imbalance value exceeds 5 g (0.17 oz), repeat installation procedures.

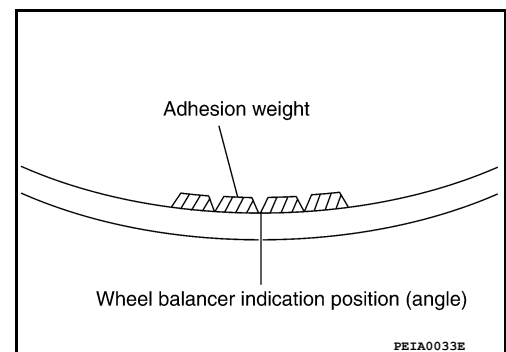

Wheel balance	Dynamic (At flange)	Static (At flange)
Maximum allowable imbalance	Refer to <a href="#">WT-61, "Road Wheel"</a> .	

A  
B  
C  
D  
E  
F  
G  
H  
I  
J  
K  
L  
M  
N  
O

MA

# CHASSIS AND BODY MAINTENANCE

## < PERIODIC MAINTENANCE >

### TIRE ROTATION

- Follow the maintenance schedule for tire rotation service intervals. Refer to [MA-9, "FOR USA AND CANADA : Introduction of Periodic Maintenance"](#) (USA and CANADA) or [MA-12, "FOR MEXICO : Introduction of Periodic Maintenance"](#) (MEXICO).
- When installing the wheel, tighten wheel nuts to the specified torque.

#### CAUTION:

- Do not include the spare tire when rotating the tires.
- When installing wheels, tighten them diagonally by dividing the work two to three times in order to prevent the wheels from developing any distortion.
- Be careful not to tighten wheel nut at torque exceeding the criteria for preventing strain of disc rotor.
- Use NISSAN genuine wheel nuts for aluminum wheels.

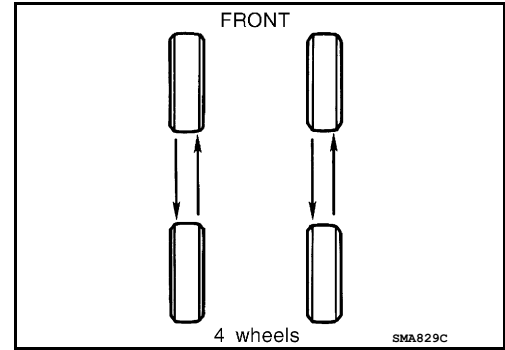

**Wheel nut tightening torque : 113 N·m (12 kg-m, 83 ft-lb)**

- Perform the ID registration after tire rotation. Refer to [WT-24, "Description"](#).

### BRAKE FLUID LEVEL AND LEAKS

#### BRAKE FLUID LEVEL AND LEAKS : Inspection

INFOID:000000011132019

#### BRAKE FLUID LEVEL

- Make sure that the brake fluid level in the reservoir sub tank is between the MAX and MIN lines.
- Visually check around the reservoir sub tank and reservoir tank for brake fluid leakage.
- If the brake fluid level is excessively low, check the brake system for leakage.
- If brake warning lamp remains illuminated after parking brake pedal is released, check the brake system for brake fluid leakage.

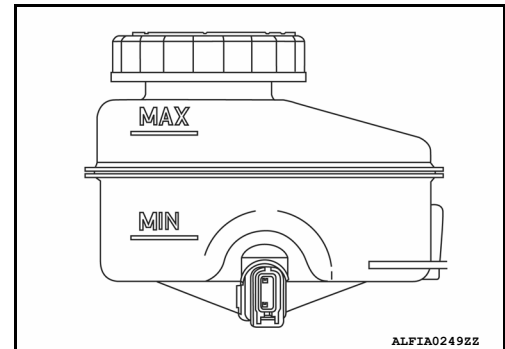

#### BRAKE LINE

1. Check brake line (tubes and hoses) for cracks, deterioration or other damage. Replace any damaged parts.
2. Check for brake fluid leakage by fully depressing brake pedal while engine is running.

#### CAUTION:

**If brake fluid leakage occurs around joints, retighten or replace damaged parts as necessary.**

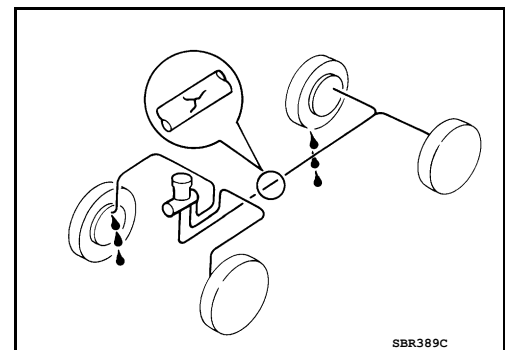

### BRAKE LINES AND CABLES

# CHASSIS AND BODY MAINTENANCE

< PERIODIC MAINTENANCE >

## BRAKE LINES AND CABLES : Inspection

INFOID:000000011132020

- Check brake fluid lines and parking brake cables for improper attachment, leaks, chafing, abrasions, deterioration, etc.

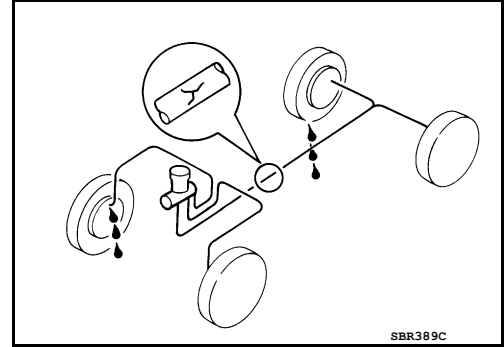

## BRAKE FLUID

### BRAKE FLUID : Drain and Refill

INFOID:000000011132021

#### CAUTION:

- Do not spill or splash brake fluid on painted surfaces. Brake fluid may damage paint. If brake fluid is splashed on painted areas, wash it away with water immediately.
- Prior to repair, turn the ignition switch OFF, disconnect the ABS actuator and electric unit (control unit) connector or negative battery terminal. Refer to [PG-99, "Removal and Installation"](#).
- Refill brake system with new brake fluid. Refer to [MA-15, "FOR USA AND CANADA : Fluids and Lubricants"](#) (United States and Canada) or [MA-16, "FOR MEXICO : Fluids and Lubricants"](#) (Mexico).
- Do not reuse drained brake fluid.

### DRAINING

1. Turn ignition switch OFF and disconnect ABS actuator and electric unit (control unit) connector or negative battery terminal. Refer to [PG-99, "Removal and Installation"](#).
2. Connect a vinyl tube to bleeder valve.
3. Depress brake pedal, loosen bleeder valve, and gradually remove brake fluid.

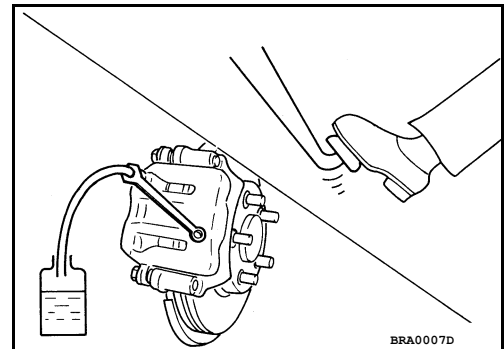

### REFILLING

1. Make sure no foreign material is in the reservoir sub-tank, and refill with new brake fluid.

#### CAUTION:

**Do not reuse drained brake fluid.**

2. Refill the brake system as follows:
  - Depress the brake pedal.
  - Loosen bleeder valve.
  - Slowly depress brake pedal to 2/3 of the brake pedal full stroke.
  - Tighten bleeder valve.
  - Release brake pedal.

Repeat this operation at intervals of two or three seconds until all old brake fluid is discharged. Add new brake fluid to master cylinder reservoir sub tank frequently.

#### CAUTION:

**Do not allow master cylinder reservoir to empty as this may cause damage to master cylinder internal components.**

3. Bleed the air out of the brake hydraulic system. Refer to [BR-16, "Bleeding Brake System"](#).

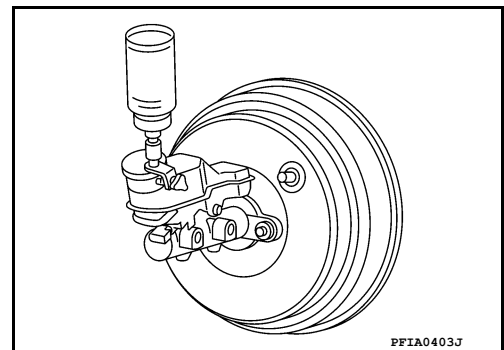

A  
B  
C  
D  
E  
F  
G  
H  
I  
J  
K  
L  
M  
N  
O

MA

# CHASSIS AND BODY MAINTENANCE

< PERIODIC MAINTENANCE >

## FRONT BRAKE

### FRONT BRAKE : Inspection of Pad

INFOID:000000011132022

Check brake pad wear thickness from an inspection hole (A) on cylinder body. Check using a scale if necessary.

**Wear thickness** : Refer to [BR-49, "Front Disc Brake"](#).

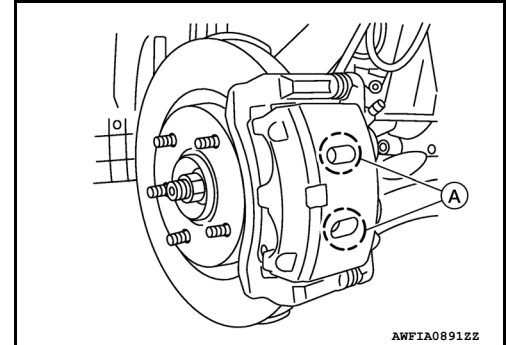

### FRONT BRAKE : Inspection of Rotor

INFOID:000000011132023

#### VISUAL

Check surface of disc rotor for uneven wear, cracks or damage. Replace if any abnormal conditions exist.

#### THICKNESS

Check the thickness of the disc rotor using a micrometer. Replace the disc rotor if the thickness is below the wear limit.

**Wear thickness** : Refer to [BR-49, "Front Disc Brake"](#).

**Thickness variation** : Refer to [BR-49, "Front Disc Brake"](#).

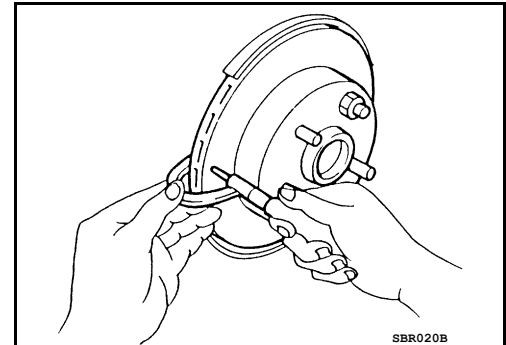

## REAR BRAKE

### REAR BRAKE : Inspection of Pad

INFOID:000000011132024

#### INSPECTION

Check brake pad wear thickness from an inspection hole (A) on cylinder body. Check using a scale if necessary.

**Wear thickness** : Refer to [BR-49, "Rear Disc Brake"](#).

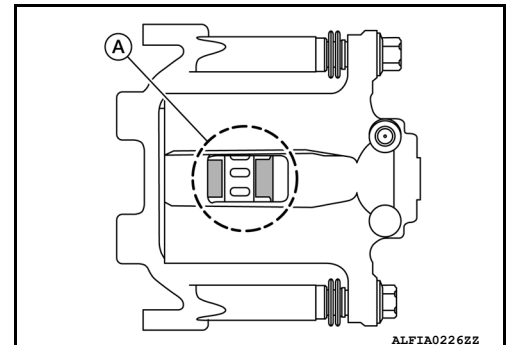

### REAR BRAKE : Inspection of Rotor

INFOID:000000011132025

#### VISUAL

Check surface of disc rotor for uneven wear, cracks or damage. Replace if any abnormal conditions exist.

#### THICKNESS



# CHASSIS AND BODY MAINTENANCE

## < PERIODIC MAINTENANCE >

Check the thickness of the disc rotor using a micrometer. Replace the disc rotor if the thickness is below the minimum thickness.

**Minimum thickness** : Refer to [BR-49, "Rear Disc Brake"](#).

**Thickness variation** : Refer to [BR-49, "Rear Disc Brake"](#).

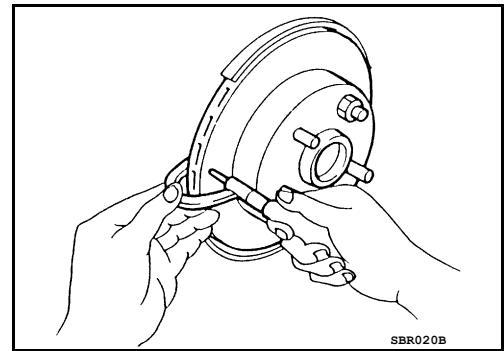

## STEERING GEAR AND LINKAGE

### STEERING GEAR AND LINKAGE : Inspection

INFOID:000000011132026

#### STEERING GEAR

- Check gear housing and boots for looseness, damage and grease leakage.
- Check connection with steering column for looseness.

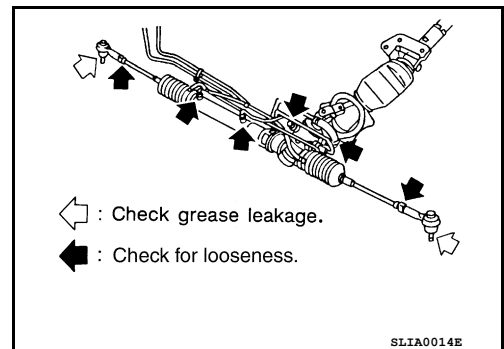

#### STEERING LINKAGE

Check ball joint, dust cover and other component parts for looseness, wear, damage and grease leakage.

## POWER STEERING FLUID AND LINES

### POWER STEERING FLUID AND LINES : Inspection

INFOID:000000011132027

#### FLUID LEVEL

Check power steering fluid level at the scale on reservoir tank cap indicator.

- Check power steering fluid level with engine stopped and the fluid temp between 0 – 30° C (32 – 86° F).
- Power steering fluid level should be between the hatching area of the indicator on the power steering reservoir tank cap.

#### **CAUTION:**

- **Do not overfill.**
- **Do not reuse used power steering fluid.**
- **Recommended power steering fluid is Genuine NISSAN E-PSF or equivalent. Refer to [MA-15, "FOR USA AND CANADA : Fluids and Lubricants"](#) (United States and Canada) or [MA-16, "FOR MEXICO : Fluids and Lubricants"](#) (Mexico).**

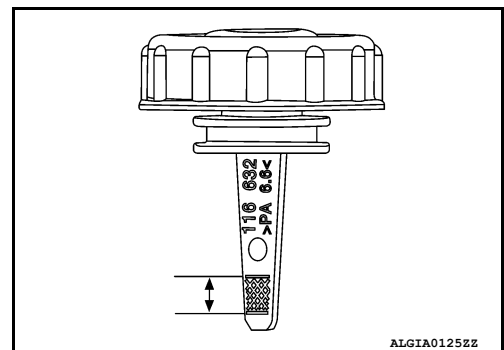

#### FLUID LEAKAGE

A  
B  
C  
D  
E  
F  
G  
H  
I  
J  
K  
L  
M  
N  
O

MA

# CHASSIS AND BODY MAINTENANCE

## < PERIODIC MAINTENANCE >

Check the power steering hydraulic system for leaks, cracks, damage, loose connections, chafing or deterioration. Repair or replace as necessary.

1. Start engine and allow engine to idle.
2. Turn steering wheel right-to-left several times.
3. Hold steering wheel at each "lock" position for five seconds to check fluid leakage.

**CAUTION:**

**Do not hold steering wheel in a locked position for more than 10 seconds. Damage to power steering oil pump may occur.**

4. If power steering fluid leakage at connections is noticed, loosen flare nut and retighten.

**CAUTION:**

**Do not over tighten flare nut as damage to O-ring and connection can occur.**

5. If power steering fluid leakage from the power steering oil pump is noticed, repair connection or replace power steering oil pump. Refer to [ST-55, "Removal and Installation"](#).
6. Check steering gear boots for accumulation of power steering fluid. Power steering fluid indicates a leak from the power steering gear, replace as necessary. Refer to [ST-60, "Removal and Installation - FWD"](#) (FWD) or [ST-62, "Removal and Installation - AWD"](#) (AWD).

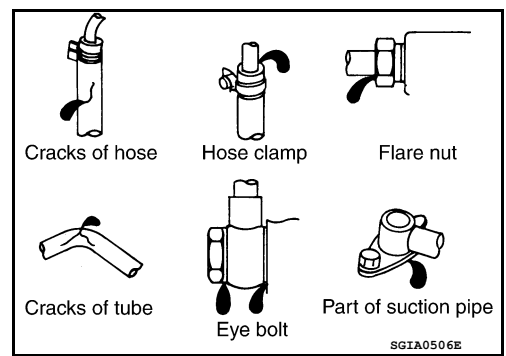

## AXLE AND SUSPENSION PARTS

### AXLE AND SUSPENSION PARTS : Inspection

INFOID:000000011132028

Check front and rear axle and suspension parts for excessive play, cracks, wear or other damage.

- Shake each wheel to check for excessive play.
- Check wheel bearings for smooth operation.
- Check axle and suspension nuts and bolts for looseness.
- Check strut (shock absorber) for oil leakage or other damage.
- Check suspension ball joint for grease leakage and ball joint dust cover for cracks or other damage.

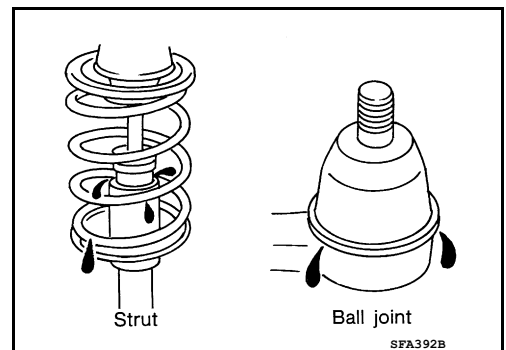
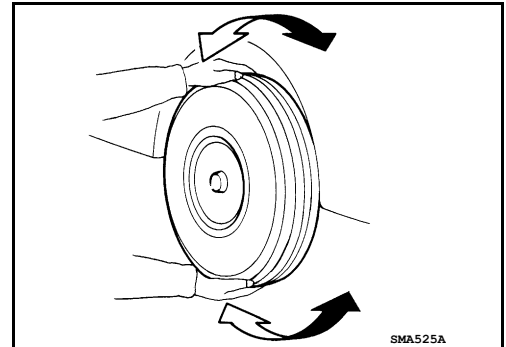

## DRIVE SHAFT

# CHASSIS AND BODY MAINTENANCE

< PERIODIC MAINTENANCE >

## DRIVE SHAFT : Inspection

INFOID:000000011132029

Check boot and drive shaft for cracks, wear, damage and grease leakage.

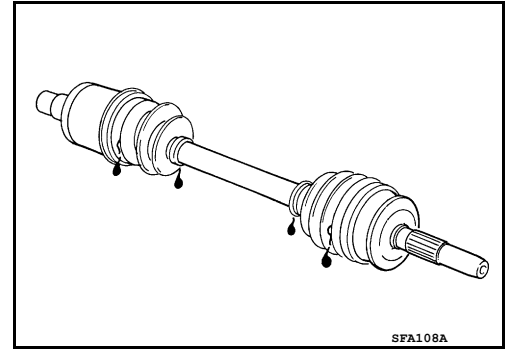

## LOCKS, HINGES AND HOOD LATCH

### LOCKS, HINGES AND HOOD LATCH : Lubricating

INFOID:000000011132030

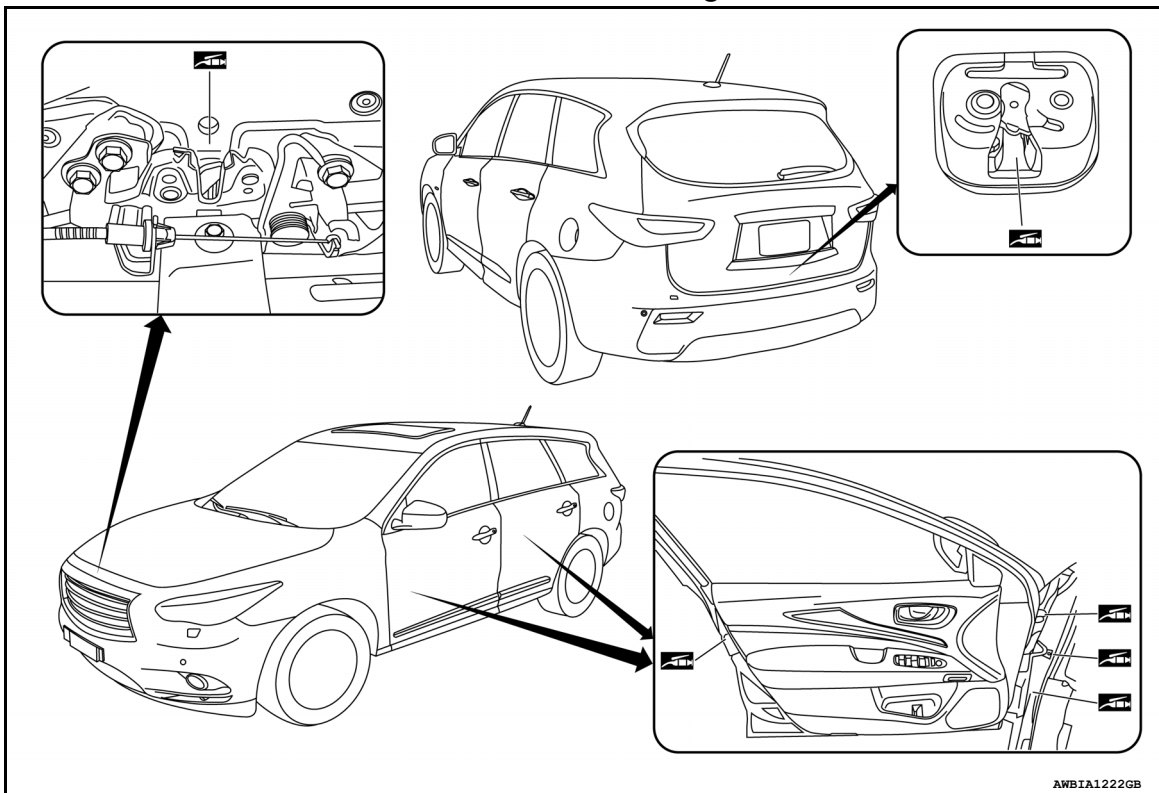

## SEAT BELT, BUCKLES, RETRACTORS, ANCHORS AND ADJUSTERS

### SEAT BELT, BUCKLES, RETRACTORS, ANCHORS AND ADJUSTERS : Inspection

INFOID:000000011132031

For details, refer to [SBC-54. "Diagnosis Procedure"](#) in SB section.

- Check anchors for loose mounting.
- Check belts for damage.
- Check retractor for smooth operation.
- Check function of buckles and tongues when buckled and released.

#### **CAUTION:**

- **After any collision, inspect all seat belt assemblies, including retractors and other attached hardware (i.e., anchor bolt, guide rail set). INFINITI recommends replacing all seat belt assemblies in use during a collision, unless not damaged and properly operating after minor collision. Also inspect seat belt assemblies not in use during a collision and replace if damaged or improperly operating.**
- **Seat belt pre-tensioner should be replaced even if the seat belts are not in use during a frontal collision where the driver and passenger air bags are deployed.**

A  
B  
C  
D  
E  
F  
G  
H  
I  
J  
K  
L  
M  
N  
O

MA

## CHASSIS AND BODY MAINTENANCE

### < PERIODIC MAINTENANCE >

---

- If any component of seat belt assembly is questionable, do not repair.  
Replace as seat belt assembly.
- If webbing is cut, frayed, or damaged, replace belt assembly.
- Do not oil tongue and buckle.
- Use a genuine INFINITI seat belt assembly.