

A
B
C

SECTION **PB**

PARKING BRAKE SYSTEM

CONTENTS

<p>PRECAUTION 2</p> <p>PRECAUTIONS 2</p> <p style="padding-left: 20px;">Precaution for Supplemental Restraint System (SRS) "AIR BAG" and "SEAT BELT PRE-TENSIONER"2</p> <p>PREPARATION 3</p> <p>PREPARATION 3</p> <p style="padding-left: 20px;">Commercial Service Tool3</p> <p>PERIODIC MAINTENANCE 4</p> <p>PARKING BRAKE SYSTEM 4</p> <p style="padding-left: 20px;">Inspection and Adjustment4</p> <p>PARKING BRAKE SHOE 6</p> <p style="padding-left: 20px;">Adjustment6</p>	<p>REMOVAL AND INSTALLATION 7</p> <p>PARKING BRAKE CONTROL 7</p> <p style="padding-left: 20px;">Exploded View 7</p> <p style="padding-left: 20px;">Removal and Installation 7</p> <p style="padding-left: 20px;">Adjustment 8</p> <p>PARKING BRAKE SHOE 9</p> <p style="padding-left: 20px;">Exploded View 9</p> <p style="padding-left: 20px;">Removal and Installation 9</p> <p style="padding-left: 20px;">Inspection and Adjustment10</p> <p>SERVICE DATA AND SPECIFICATIONS (SDS)12</p> <p>SERVICE DATA AND SPECIFICATIONS (SDS)12</p> <p style="padding-left: 20px;">Parking Drum Brake12</p> <p style="padding-left: 20px;">Parking Brake Control12</p>
---	---

A
B
C
D
E
PB
G
H
I
J
K
L
M
N
O
P

PRECAUTIONS

< PRECAUTION >

PRECAUTION

PRECAUTIONS

Precaution for Supplemental Restraint System (SRS) "AIR BAG" and "SEAT BELT PRE-TENSIONER"

INFOID:000000011146843

The Supplemental Restraint System such as "AIR BAG" and "SEAT BELT PRE-TENSIONER", used along with a front seat belt, helps to reduce the risk or severity of injury to the driver and front passenger for certain types of collision. This system includes dual stage front air bag modules. The SRS system may only deploy one front air bag, depending on the severity of a collision and whether the front passenger seat is occupied. Information necessary to service the system safely is included in the SR and SB section of this Service Manual.

WARNING:

- To avoid rendering the SRS inoperative, which could increase the risk of personal injury or death in the event of a collision which would result in air bag inflation, all maintenance must be performed by an authorized NISSAN/INFINITI dealer.
- Improper maintenance, including incorrect removal and installation of the SRS, can lead to personal injury caused by unintentional activation of the system. For removal of Spiral Cable and Air Bag Module, see the SR section.
- Do not use electrical test equipment on any circuit related to the SRS unless instructed to in this Service Manual. SRS wiring harnesses can be identified by yellow and/or orange harnesses or harness connectors.

PRECAUTIONS WHEN USING POWER TOOLS (AIR OR ELECTRIC) AND HAMMERS

WARNING:

- When working near the Airbag Diagnosis Sensor Unit or other Airbag System sensors with the Ignition ON or engine running, DO NOT use air or electric power tools or strike near the sensor(s) with a hammer. Heavy vibration could activate the sensor(s) and deploy the air bag(s), possibly causing serious injury.
- When using air or electric power tools or hammers, always switch the Ignition OFF, disconnect the battery and wait at least three minutes before performing any service.

PREPARATION



< PREPARATION >

PREPARATION

PREPARATION

Commercial Service Tool

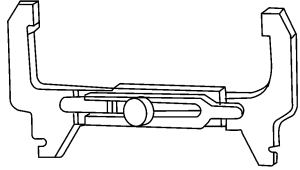
INFOID:0000000011146844

Tool name	Description
Brake drum clearance gauge  WFIA0167E	Measuring rear rotor drum inner diameter
Power tool  PIIB1407E	Loosening nuts, screws and bolts

A

B

C

D

E

PB

G

H

I

J

K

L

M

N

O

P

PARKING BRAKE SYSTEM

< PERIODIC MAINTENANCE >

PERIODIC MAINTENANCE

PARKING BRAKE SYSTEM

Inspection and Adjustment

INFOID:000000011146845

INSPECTION

Pedal Stroke

1. Operate the parking brake pedal with a force of 196 N (20.0 kg-f, 44.1 lb-f). Check that the pedal stroke is within the specified number of notches. (Check it by listening to the clicks of the ratchet.)

Number of notches : Refer to [PB-12, "Parking Brake Control"](#).

2. When brake warning lamp turns ON, check that the pedal stroke is within the specified number of notches. (Check it by listening to the clicks of the ratchet.)

Number of notches : Refer to [PB-12, "Parking Brake Control"](#).

Inspect Components

- Check each component for installation condition such as looseness.
- Check the parking brake pedal assembly for bend, damage and cracks. Replace if necessary.
- Check the cables for wear, damage and cracks. Replace if necessary.
- Check the parking brake switch, and replace it if necessary. Refer to [PB-7, "Removal and Installation"](#).

ADJUSTMENT

1. Secure the disc rotor using wheel nuts.
2. Remove fuse block lid. Refer to [IP-14, "Exploded View"](#).
3. Release the parking brake pedal (1) by turning the adjusting nut (2) with a deep socket wrench and loosening the cable.

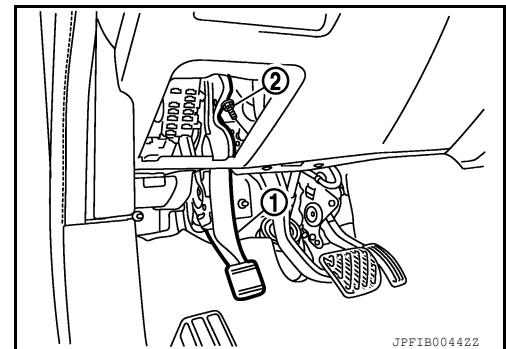

4. Remove the adjusting hole plug from the disc rotor. Turn the adjuster (1) in the direction (A) as shown using a suitable tool until the disc rotor is locked.
5. Turn back the adjuster 5 or 6 notches from the locked position.
6. Rotate the disc rotor to check that there is no drag. Install the adjusting hole plug.
7. Adjust the cable with the following procedure.
 - a. Operate the parking brake pedal with a force of 490 N (50.0 kg-f, 110.2 lb-f) for more than 30 minutes.
 - b. Adjust the parking brake pedal stroke by turning the adjusting nut with a deep socket wrench.

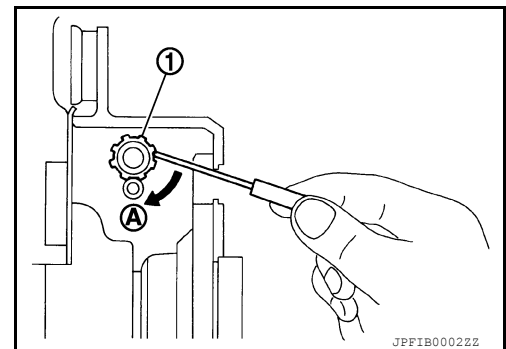

CAUTION:

Do not reuse the adjusting nut if the nut is removed.

- c. Operate the parking brake pedal with a force of 196 N (20.0 kg-f, 44.1 lb-f). Check that the pedal stroke is within the specified number of notches. (Check it by listening to the clicks of the ratchet.)

Number of notches : Refer to [PB-12, "Parking Brake Control"](#).

PARKING BRAKE SYSTEM

< PERIODIC MAINTENANCE >

- d. Rotate the disc rotor with the parking brake pedal released and check that there is no drag.

CAUTION:

If any drag is found, verify the parking brake components are installed and adjusted correctly.

A

B

C

D

E

PB

G

H

I

J

K

L

M

N

O

P

PARKING BRAKE SHOE

< PERIODIC MAINTENANCE >

PARKING BRAKE SHOE

Adjustment

INFOID:000000011146846

1. Adjust parking brake pedal stroke. Refer to [PB-4, "Inspection and Adjustment"](#).
2. Perform parking brake break-in (drag on) operation by driving vehicle under the following conditions:
 - Drive forward
 - Vehicle speed: Approx. 40 km/h (25 MPH) set (constant and forward)
 - Parking brake operating force: Approx. 160 +49, -0 N (16.3 +5, -0 kg-f, 36.0 +11, -0 lb-f)
 - Time: Approx. 5 +5, -0 seconds.

CAUTION:

To prevent lining from getting too hot, allow a cool off period of approximately 5 minutes after every break-in operation.

3. After the break-in procedure, check parking pedal stroke of parking brake.

CAUTION:

If it is out of the specification, adjust again. Refer to [PB-4, "Inspection and Adjustment"](#).

PARKING BRAKE CONTROL

< REMOVAL AND INSTALLATION >

REMOVAL AND INSTALLATION

PARKING BRAKE CONTROL

Exploded View

INFOID:0000000011146847

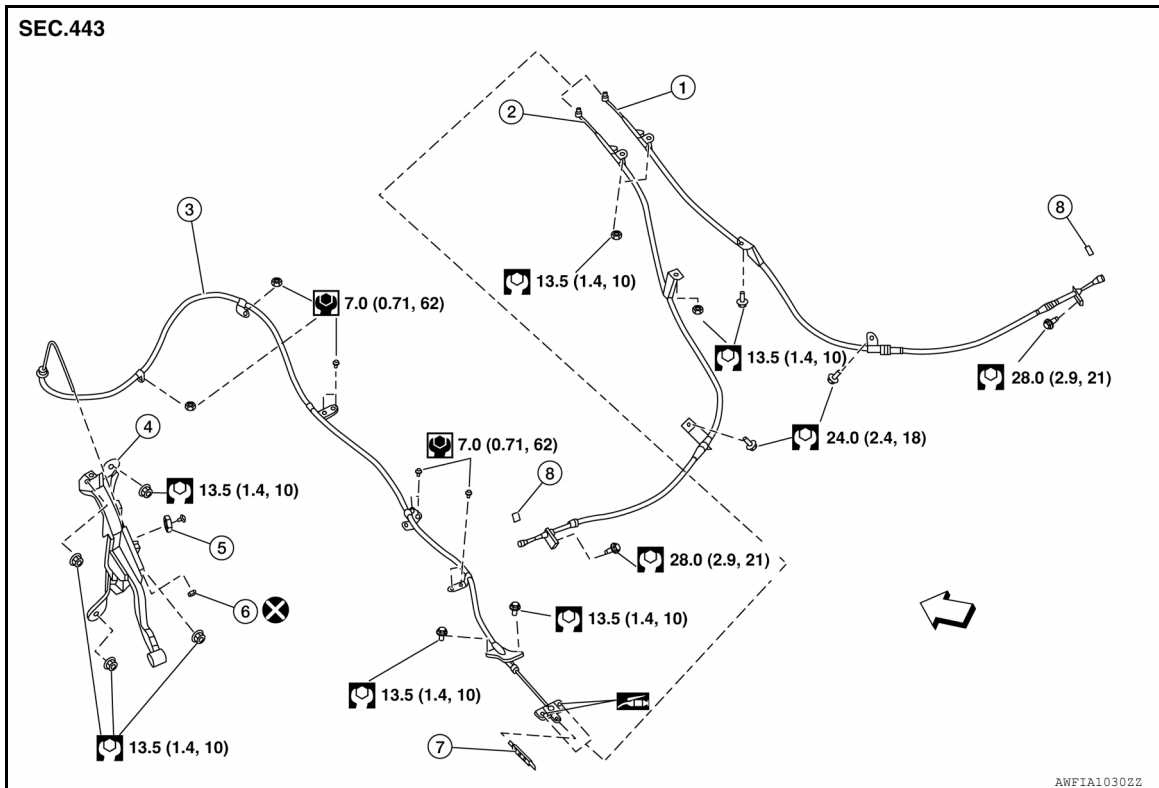

- | | | |
|---------------------------------|----------------------|------------------|
| 1. Rear cable (RH) | 2. Rear cable (LH) | 3. Front cable |
| 4. Parking brake pedal assembly | 5. Park brake switch | 6. Adjusting nut |
| 7. Return spring | 8. Pin | |

Removal and Installation

INFOID:0000000011146848

REMOVAL

1. Disconnect the negative and positive battery terminals, then wait at least three minutes. Refer to [PG-99, "Removal and Installation"](#).
2. Remove lower instrument panel LH. [IP-25, "Removal and Installation"](#).
3. Disconnect the harness connector from the parking brake switch.
4. Remove parking brake pedal assembly nuts and lower parking brake pedal assembly.
5. Remove adjusting nut and front cable from parking brake pedal assembly.
6. Remove front floor duct RH. Refer to [VTL-11, "FRONT FLOOR DUCT : Removal and Installation - Front Floor Duct"](#).
7. Remove center blower unit. Refer to [VTL-20, "REAR BLOWER MOTOR 1 UNIT ASSEMBLY : Removal and Installation"](#).
8. Separate front cable from rear cable and remove front cable and return spring.
9. Remove parking brake shoe and remove rear cable from toggle lever. Refer to [PB-9, "Removal and Installation"](#).
10. Remove rear cable bolts, nuts, and rear cable from vehicle.

INSTALLATION

Installation is in the reverse order of the removal.

PARKING BRAKE CONTROL

< REMOVAL AND INSTALLATION >

CAUTION:

Do not reuse the adjusting nut.

Adjustment

INFOID:000000011146849

ADJUSTMENT AFTER INSTALLATION

Adjust the parking brake pedal stroke. Refer to [PB-4. "Inspection and Adjustment"](#).

PARKING BRAKE SHOE

< REMOVAL AND INSTALLATION >

PARKING BRAKE SHOE

Exploded View

INFOID:000000011146850

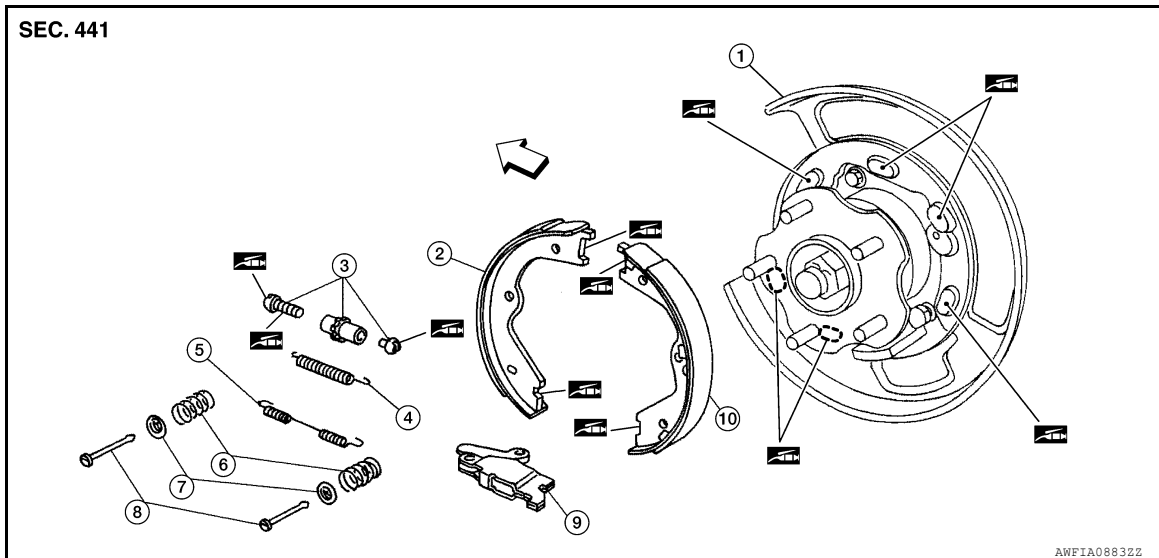

- | | | |
|-------------------------------|-------------------------------|--|
| 1. Back plate | 2. Parking brake shoe (front) | 3. Adjuster |
| 4. Adjuster spring | 5. Return spring | 6. Anti-rattle spring |
| 7. Retainer | 8. Anti-rattle pin | 9. Toggle lever |
| 10. Parking brake shoe (rear) | ↩ Front | 🖱️ Apply PBC (Poly Butyl Cuprysil) grease or silicone based grease |

Removal and Installation

INFOID:000000011146851

REMOVAL

WARNING:

Clean dust on the parking brake shoes with a vacuum dust collector to minimize the hazard of air borne particles or other materials.

1. Remove the rear wheel and tire using power tool. Refer to [WT-53, "Adjustment"](#).
2. Remove disc rotor. Refer to [BR-40, "BRAKE CALIPER ASSEMBLY : Removal and Installation"](#).

CAUTION:

Parking brake must be in the completely released position.

3. If disc rotor cannot be removed, remove as follows:
 - a. Secure the disc rotor with wheel nuts and remove the adjusting hole plug.
 - b. Using a suitable tool, rotate adjuster (1) in direction (B) to retract and loosen parking brake shoe.
4. Remove anti-rattle pins, retainers, anti-rattle springs, adjuster spring and return spring.

CAUTION:

Do not drop the removed parts.

5. Remove parking brake shoes, adjuster assembly and toggle lever.

CAUTION:

- The parking brake shoes for the front side are made of different materials from those for the rear side. Do not misidentify them when removing.
- Do not drop the removed parts.

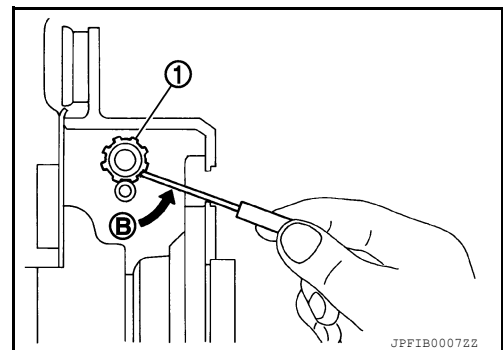

INSTALLATION

Installation is in the reverse order of removal.

PARKING BRAKE SHOE

< REMOVAL AND INSTALLATION >

- Apply PBC (Poly Butyl Cuprysil) grease or silicone-based grease to the back plate and brake shoe.

CAUTION:

The parking brake shoes for the front side are made of different materials from those for the rear side. Do not misidentify them when removing and replacing.

- Assemble adjusters so that threaded part is expanded when rotating it in the direction shown by arrow.

- (A) : For RH brake
- (B) : For LH brake
- ↶ : Front
- ← : Adjuster expands

- Shorten adjuster by rotating it.
- When assembling the adjuster, apply PBC (Poly Butyl Cuprysil) grease or silicone-based grease to threads and pivot.
- Check parking brake shoe lining and drum inner surface for grease. Wipe off any grease on the surfaces.

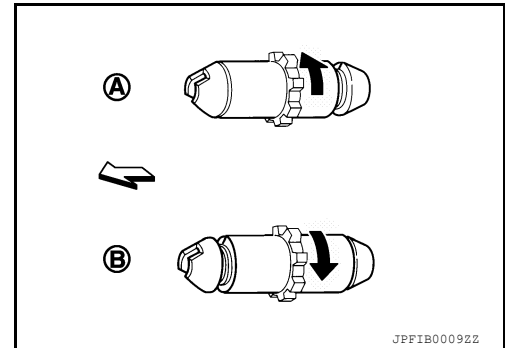

Inspection and Adjustment

INFOID:000000011146852

INSPECTION

Brake Lining Thickness Inspection

- Check thickness (A) of brake lining.

Limit (A) : Refer to [PB-12, "Parking Drum Brake"](#).

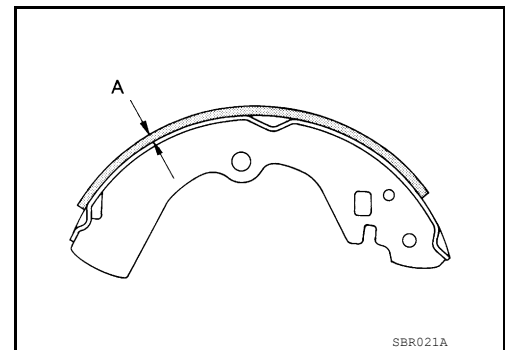

Drum Inner Diameter Inspection

- Check inner diameter (B) of drum using suitable tool.

Limit (B) : Refer to [PB-12, "Parking Drum Brake"](#).

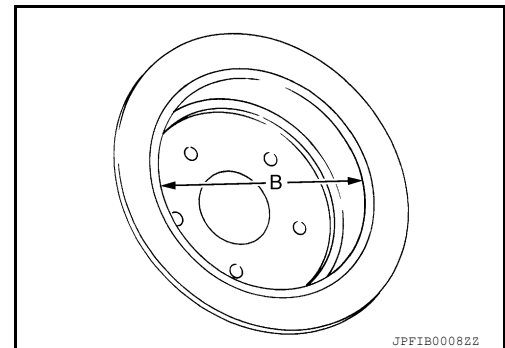

Other Inspections

- Check brake lining for excessive wear, damage, and peeling. Replace if necessary.
- Check parking brake shoe for excessive wear and damage. Replace if necessary.
- Check anti-rattle pins and retainers for excessive wear, damage and rust. Replace if necessary.
- Check adjuster spring, anti-rattle spring and return springs for settling, excessive wear, damage, and rust. Replace if necessary.
- Check adjuster for binding. Replace if necessary.
- Check toggle lever for excessive wear, damage and rust. Replace if necessary.
- Visually check inside of the drum for rust, cracks, damage or excessive wear with a suitable tool. Replace if necessary.

ADJUSTMENT

- Adjust the parking brake pedal stroke. Refer to [PB-4, "Inspection and Adjustment"](#).

PARKING BRAKE SHOE

< REMOVAL AND INSTALLATION >

2. Rotate the disc rotor with the parking brake pedal released and check that there is no drag.

CAUTION:

If any drag is found, verify the parking brake components are installed and adjusted correctly.

A

B

C

D

E

PB

G

H

I

J

K

L

M

N

O

P

SERVICE DATA AND SPECIFICATIONS (SDS)

< SERVICE DATA AND SPECIFICATIONS (SDS)

SERVICE DATA AND SPECIFICATIONS (SDS)

SERVICE DATA AND SPECIFICATIONS (SDS)

Parking Drum Brake

INFOID:0000000011146853

Unit: mm (in)

	Item	Limit
Brake lining	Thickness	3.33 (0.131)
	Wear thickness	1.5 (0.059)
Drum	Inner diameter	190 (7.480)
	Wear limit of inner diameter	191 (7.520)

Parking Brake Control

INFOID:0000000011146854

Item	Standard
Number of notches [under force of 196 N (20.0 kg-f, 44.1 lb-f)]	5 – 6 notches
Number of notches when brake warning lamp turns ON	1 notch