

SECTION **SR**  
SRS AIRBAG

A  
B  
C  
D  
E  
F  
G  
SR  
I  
J  
K  
L  
M  
N  
O  
P

CONTENTS

<b>PRECAUTION</b> .....	2	<b>FRONT PASSENGER AIR BAG MODULE</b> .....	18
<b>PRECAUTIONS</b> .....	2	Exploded View .....	18
Precaution for Supplemental Restraint System (SRS) "AIR BAG" and "SEAT BELT PRE-TENSIONER" .....	2	Removal and Installation .....	18
Service .....	2	<b>SIDE CURTAIN AIR BAG MODULE</b> .....	20
Precaution for Work .....	2	Exploded View .....	20
<b>PREPARATION</b> .....	4	Removal and Installation .....	20
<b>PREPARATION</b> .....	4	<b>FRONT SIDE AIR BAG MODULE</b> .....	22
Special Service Tools .....	4	Removal and Installation .....	22
<b>BASIC INSPECTION</b> .....	5	<b>CRASH ZONE SENSOR</b> .....	23
<b>COLLISION DIAGNOSIS</b> .....	5	Exploded View .....	23
For Frontal Collision .....	5	Removal and Installation .....	23
For Side and Rollover Collision .....	7	<b>SATELLITE SENSOR</b> .....	24
<b>REMOVAL AND INSTALLATION</b> .....	12	Exploded View .....	24
<b>DRIVER AIR BAG MODULE</b> .....	12	Removal and Installation .....	25
Exploded View .....	12	<b>AIR BAG DIAGNOSIS SENSOR UNIT</b> .....	27
Removal and Installation .....	12	Exploded View .....	27
<b>SPIRAL CABLE</b> .....	15	Removal and Installation .....	27
Exploded View .....	15	<b>SEAT BELT PRE-TENSIONER</b> .....	29
Removal and Installation .....	15	Removal and Installation .....	29
		<b>FRONT SEAT BELT BUCKLE SWITCH</b> .....	30
		Removal and Installation .....	30
		<b>OCCUPANT CLASSIFICATION SYSTEM</b> .....	31
		Removal and Installation .....	31

# PRECAUTIONS

< PRECAUTION >

## PRECAUTION

### PRECAUTIONS

#### Precaution for Supplemental Restraint System (SRS) "AIR BAG" and "SEAT BELT PRE-TENSIONER"

INFOID:000000011145545

The Supplemental Restraint System such as "AIR BAG" and "SEAT BELT PRE-TENSIONER", used along with a front seat belt, helps to reduce the risk or severity of injury to the driver and front passenger for certain types of collision. This system includes dual stage front air bag modules. The SRS system may only deploy one front air bag, depending on the severity of a collision and whether the front passenger seat is occupied. Information necessary to service the system safely is included in the SR and SB section of this Service Manual.

#### **WARNING:**

- To avoid rendering the SRS inoperative, which could increase the risk of personal injury or death in the event of a collision which would result in air bag inflation, all maintenance must be performed by an authorized NISSAN/INFINITI dealer.
- Improper maintenance, including incorrect removal and installation of the SRS, can lead to personal injury caused by unintentional activation of the system. For removal of Spiral Cable and Air Bag Module, see the SR section.
- Do not use electrical test equipment on any circuit related to the SRS unless instructed to in this Service Manual. SRS wiring harnesses can be identified by yellow and/or orange harnesses or harness connectors.

#### PRECAUTIONS WHEN USING POWER TOOLS (AIR OR ELECTRIC) AND HAMMERS

#### **WARNING:**

- When working near the Airbag Diagnosis Sensor Unit or other Airbag System sensors with the Ignition ON or engine running, DO NOT use air or electric power tools or strike near the sensor(s) with a hammer. Heavy vibration could activate the sensor(s) and deploy the air bag(s), possibly causing serious injury.
- When using air or electric power tools or hammers, always switch the Ignition OFF, disconnect the battery and wait at least three minutes before performing any service.

#### Service

INFOID:000000011145546

- Do not use electrical test equipment to check SRS circuits unless instructed to in this Service Manual.
- Before servicing the SRS, turn ignition switch OFF, disconnect both battery cables and wait at least three minutes.  
For approximately three minutes after the cables are removed, it is still possible for the air bag and seat belt pre-tensioner to deploy. Therefore, do not work on any SRS connectors or wires until at least three minutes have passed.
- Diagnosis sensor unit must always be installed with their arrow marks "⇐" pointing towards the front of the vehicle for proper operation. Also check diagnosis sensor unit for cracks, deformities or rust before installation and replace as required.
- The spiral cable must be aligned with the neutral position since its rotations are limited. Do not turn steering wheel and column after removal of steering gear.
- Handle air bag module carefully. Always place driver and front passenger air bag modules with the pad side facing upward and seat mounted front side air bag module standing with the stud bolt side facing down.
- Conduct self-diagnosis to check entire SRS for proper function after replacing any components.
- After air bag inflates, the instrument panel assembly should be replaced if damaged.
- Always replace instrument panel pad following front passenger air bag deployment.

#### Precaution for Work

INFOID:000000011145548

- When removing or disassembling each component, be careful not to damage or deform it. If a component may be subject to interference, be sure to protect it with a shop cloth.
- When removing (disengaging) components with a screwdriver or similar tool, be sure to wrap the component with a shop cloth or vinyl tape to protect it.
- Protect the removed parts with a shop cloth and prevent them from being dropped.
- Replace a deformed or damaged clip.
- If a part is specified as a non-reusable part, always replace it with a new one.

## PRECAUTIONS

### < PRECAUTION >

---

- Be sure to tighten bolts and nuts securely to the specified torque.
- After installation is complete, be sure to check that each part works properly.
- Follow the steps below to clean components:
  - Water soluble dirt:
    - Dip a soft cloth into lukewarm water, wring the water out of the cloth and wipe the dirty area.
    - Then rub with a soft, dry cloth.
  - Oily dirt:
    - Dip a soft cloth into lukewarm water with mild detergent (concentration: within 2 to 3%) and wipe the dirty area.
    - Then dip a cloth into fresh water, wring the water out of the cloth and wipe the detergent off.
    - Then rub with a soft, dry cloth.
  - Do not use organic solvent such as thinner, benzene, alcohol or gasoline.
  - For genuine leather seats, use a genuine leather seat cleaner.

A

B

C

D

E

F

G

SR

I

J

K

L

M

N

O

P

# PREPARATION

< PREPARATION >

## PREPARATION

### PREPARATION

#### Special Service Tools

INFOID:000000011145549

The actual shape of the tools may differ from those illustrated here.

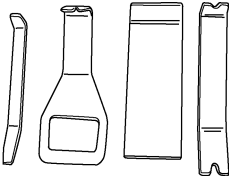
Tool number (TechMate No.) Tool name	Description
— (J-46534) Trim Tool Set  AWJIA0483ZZ	Removing trim components

# COLLISION DIAGNOSIS

< BASIC INSPECTION >

## BASIC INSPECTION

### COLLISION DIAGNOSIS

#### For Frontal Collision

INFOID:000000011145550

FOR FRONTAL COLLISION: When SRS is activated in a collision

#### CAUTION:

Due to varying models and option levels, not all parts listed in the chart below apply to all vehicles.

#### WORK PROCEDURE

1. Before performing any of the following steps, ensure that all vehicle body and structural repairs have been completed.
2. Replace the diagnosis sensor unit.
3. Remove the front air bag modules, crash zone sensor assembly, bracket and seat belt pre-tensioner assemblies.
4. Check the SRS components using the table below:  
Replace any SRS components showing visible signs of damage. (dents, cracks and deformation, etc.)
5. Install new front air bag modules, crash zone sensor assembly, bracket and seat belt pre-tensioner assemblies.
6. Perform self-diagnosis using CONSULT or air bag warning lamp. Refer to [SRC-15. "Diagnosis Description"](#) for details.  
Ensure entire SRS operates properly.
7. After the work is completed, perform self-diagnosis to check that no malfunction is detected. Refer to [SRC-15. "SRS Operation Check"](#).

#### SRS INSPECTION (FOR FRONTAL COLLISION)

Part	Inspection
Driver air bag module	If the driver air bag has deployed: REPLACE Install with new fasteners.
Front passenger air bag module (if equipped)	If the front passenger air bag has deployed: REPLACE Install with new fasteners.
Crash zone sensor	If any of the front air bags or seat belt pre-tensioners* have been activated: REPLACE the crash zone sensor and bracket with new fasteners. *: Confirm seat belt pre-tensioner activation using CONSULT only.
Seat belt pre-tensioner assemblies (All applicable locations: buckle, retractor, lap outer)	If either the driver or passenger seat belt pre-tensioner* has been activated: REPLACE all seat belt pre-tensioner assemblies with new fasteners. *: Confirm seat belt pre-tensioner activation using CONSULT only.
Diagnosis sensor unit	If any of the SRS components have been activated: REPLACE the diagnosis sensor unit. Install with new fasteners.
Steering wheel	<ol style="list-style-type: none"> <li>1. Visually check steering wheel for deformities.</li> <li>2. Check harness (built into steering wheel) and connectors for damage, and terminals for deformities.</li> <li>3. Install driver air bag module into the steering wheel to check fit and alignment with the wheel.</li> <li>4. Check steering wheel for excessive free play.</li> <li>5. If no damage is found, reinstall.</li> <li>6. If damaged — REPLACE.</li> </ol>
Spiral cable	If the driver front air bag has deployed: REPLACE the spiral cable.

# COLLISION DIAGNOSIS

## < BASIC INSPECTION >

Part	Inspection
Occupant classification system (Passenger seat) (except Mexico)	<ol style="list-style-type: none"> <li>1. Remove passenger seat assembly.</li> <li>2. Check control unit case for dents, cracks or deformities.</li> <li>3. Check connectors for damage and terminals for deformities.</li> <li>4. Check seat frame and cushion pan for dents or deformities.</li> <li>5. If no damage is found, reinstall seat with new fasteners.</li> <li>6. If damaged — REPLACE seat cushion assembly with new fasteners.</li> <li>7. Perform zero point reset function after front passenger seat is installed in the vehicle and all bolts are tightened to specification. Refer to <a href="#">SRC-42. "ZERO POINT RESET : Description"</a>.</li> </ol>
Harness and connectors	<ol style="list-style-type: none"> <li>1. Check connectors for poor connection, damage, and terminals for deformities.</li> <li>2. Check harness for binding, chafing, cuts, or deformities.</li> <li>3. If no damage is found, reinstall the harness and connectors.</li> <li>4. If damaged — REPLACE the damaged harness. Do not attempt to repair, splice or modify any SRS harness.</li> </ol>
Instrument panel assembly	If the passenger front air bag has deployed: REPLACE the instrument panel assembly. (integrated type)

FOR FRONTAL COLLISION: When SRS is not activated in a collision

### CAUTION:

**Due to varying models and option levels, not all parts listed in the chart below apply to all vehicles.**

#### WORK PROCEDURE

1. Before performing any of the following steps, ensure that all vehicle body and structural repairs have been completed.
2. Check the SRS components using the table below:  
Replace any SRS components showing visible signs of damage. (dents, cracks and deformation, etc.)
3. Perform self-diagnosis using CONSULT or air bag warning lamp. Refer to [SRC-15. "Diagnosis Description"](#) for details.  
Ensure entire SRS operates properly.
4. After the work is completed, perform self-diagnosis to check that no malfunction is detected. Refer to [SRC-15. "SRS Operation Check"](#).

#### SRS INSPECTION (FOR FRONTAL COLLISION)

Part	Inspection
Driver air bag module	<p>If the driver air bag has NOT been activated:</p> <ol style="list-style-type: none"> <li>1. Remove driver air bag module. Check harness cover and connectors for damage, terminals for deformities, and harness for binding.</li> <li>2. Install driver air bag module into the steering wheel to check fit and alignment with the wheel.</li> <li>3. If no damage is found, reinstall with new fasteners.</li> <li>4. If damaged — REPLACE. Install driver air bag modules with new fasteners.</li> </ol>
Front passenger air bag module (if equipped)	<p>If the front passenger air bag has NOT been activated:</p> <ol style="list-style-type: none"> <li>1. Remove front passenger air bag module. Check harness cover and connectors for damage, terminals for deformities, and harness for binding.</li> <li>2. Install front passenger air bag module into the instrument panel to check fit with the instrument panel.</li> <li>3. If no damage is found, reinstall with new fasteners.</li> <li>4. If damaged — REPLACE. Install front passenger air bag modules with new fasteners.</li> </ol>
Crash zone sensor	<p>If the front air bags or seat belt pre-tensioners have NOT been activated:</p> <ol style="list-style-type: none"> <li>1. Remove the crash zone sensor. Check harness connectors for damage, terminals for deformities, and harness for binding.</li> <li>2. Check for visible signs of damage (dents, cracks, deformation) of the crash zone sensor and bracket.</li> <li>3. Install the crash zone sensor to check fit.</li> <li>4. If no damage is found, reinstall with new fasteners.</li> <li>5. If damaged — REPLACE the crash zone sensor and bracket with new fasteners.</li> </ol>

# COLLISION DIAGNOSIS

## < BASIC INSPECTION >

Part	Inspection
Seat belt pre-tensioner assemblies (All applicable locations: buckle, retractor, lap outer)	If the pre-tensioners have NOT been activated: <ol style="list-style-type: none"> <li>1. Remove seat belt pre-tensioners. Check harness cover and connectors for damage, terminals for deformities, and harness for binding.</li> <li>2. Check belts for damage and anchors for loose mounting.</li> <li>3. Check retractor for smooth operation.</li> <li>4. Check seat belt adjuster for damage.</li> <li>5. Check for deformities of the center pillar inner.</li> <li>6. If no damage is found, reinstall seat belt pre-tensioner assembly with new fasteners.</li> <li>7. If damaged —REPLACE. Install the seat belt pre-tensioner assembly with new fasteners.</li> </ol>
Diagnosis sensor unit	If none of the SRS components have been activated: <ol style="list-style-type: none"> <li>1. Check case for dents, cracks or deformities.</li> <li>2. Check connectors for damage, and terminals for deformities.</li> <li>3. If no damage is found, reinstall with new fasteners.</li> <li>4. If damaged — REPLACE. Install diagnosis sensor unit with new fasteners.</li> </ol>
Steering wheel	<ol style="list-style-type: none"> <li>1. Visually check steering wheel for deformities.</li> <li>2. Check harness (built into steering wheel) and connectors for damage, and terminals for deformities.</li> <li>3. Install driver air bag module into the steering wheel to check fit and alignment with the wheel.</li> <li>4. Check steering wheel for excessive free play.</li> <li>5. If no damage is found, reinstall.</li> <li>6. If damaged — REPLACE.</li> </ol>
Spiral cable	If the driver front air bag has not deployed: <ol style="list-style-type: none"> <li>1. Visually check spiral cable and combination switch for damage.</li> <li>2. Check connectors and protective tape for damage.</li> <li>3. Check steering wheel for noise, binding or heavy operation.</li> <li>4. If no damage is found, reinstall.</li> <li>5. If damaged — REPLACE.</li> </ol>
Occupant classification system (Passenger seat) (except Mexico)	<ol style="list-style-type: none"> <li>1. Remove passenger seat assembly.</li> <li>2. Check control unit case for dents, cracks or deformities.</li> <li>3. Check connectors for damage and terminals for deformities.</li> <li>4. Check seat frame and cushion pan for dents or deformities.</li> <li>5. If no damage is found, reinstall seat with new fasteners.</li> <li>6. If damaged — REPLACE seat cushion assembly with new fasteners.</li> <li>7. Perform zero point reset function after front passenger seat is installed in the vehicle and all bolts are tightened to specification. Refer to <a href="#">SRC-42, "ZERO POINT RESET : Description"</a>.</li> </ol>
Harness and connectors	<ol style="list-style-type: none"> <li>1. Check connectors for poor connection, damage, and terminals for deformities.</li> <li>2. Check harness for binding, chafing, cuts, or deformities.</li> <li>3. If no damage is found, reinstall the harness and connectors.</li> <li>4. If damaged —REPLACE the damaged harness. Do not attempt to repair, splice or modify any SRS harness.</li> </ol>
Instrument panel assembly	If the passenger front air bag has NOT deployed: <ol style="list-style-type: none"> <li>1. Visually check instrument panel for damage.</li> <li>2. If no damage is found, reinstall the instrument panel assembly.</li> <li>3. If damaged—REPLACE the instrument panel assembly.</li> </ol>

A  
B  
C  
D  
E  
F  
G  
SR  
I  
J  
K  
L  
M  
N  
O  
P

## For Side and Rollover Collision

INFOID:000000011145551

FOR SIDE AND ROLLOVER COLLISION: When SRS is activated in a collision

### **CAUTION:**

**Due to varying models and option levels, not all parts listed in the chart below apply to all vehicles.**

### WORK PROCEDURE

1. Before performing any of the following steps, ensure that all vehicle body and structural repairs have been completed.
2. Replace the following components:
  - Front seat back assembly (on the side on which side air bag is activated).
  - Door finisher (on the side on which door-mounted curtain air bag is activated).
  - Pop-up roll bar assemblies and pop-up roll bar covers.
  - Side air bag (satellite) sensor LH/RH (on the side on which side air bag is activated).
  - Diagnosis sensor unit.

# COLLISION DIAGNOSIS

## < BASIC INSPECTION >

- Seat belt pre-tensioner assemblies.
- 3. Check the SRS components and the related parts using the following table.  
Replace any SRS components and the related parts showing visible signs of damage (dents, cracks, deformation, etc.).
- 4. Perform self-diagnosis using CONSULT and "AIR BAG" warning lamp. Refer to [SRC-15, "Diagnosis Description"](#) for details. Make sure entire SRS operates properly.
- 5. After the work is completed, perform self-diagnosis to check that no malfunction is detected. Refer to [SRC-15, "SRS Operation Check"](#).

## SRS INSPECTION (FOR SIDE AND ROLLOVER COLLISION)

Part	Inspection
Side curtain air bag module LH	If the side curtain air bag LH has deployed: REPLACE the side curtain air bag module LH. Install with new fasteners.
Side curtain air bag module RH	If the side curtain air bag RH has deployed: REPLACE the side curtain air bag module RH. Install with new fasteners.
Front side air bag module LH	If the front side air bag LH has deployed: REPLACE front seatback assembly LH.
Front side air bag module RH	If the front side air bag RH has deployed: REPLACE front seatback assembly RH.
Side air bag (satellite) sensor (LH or RH)	If any of the SRS components have deployed: REPLACE the side air bag (satellite) sensor on the collision side with new fasteners.
Door (satellite) sensor (LH or RH)	If any of the SRS components have deployed: REPLACE the door (satellite) sensor on the collision side with new fasteners.
Diagnosis sensor unit	If any of the SRS components have deployed: REPLACE the diagnosis sensor unit with new fasteners.
Seat belt pre-tensioner assemblies (All applicable locations: buckle, retractor, lap outer)	If either the driver or passenger seat belt pre-tensioner* has been activated: REPLACE all seat belt pre-tensioner assemblies with new fasteners. *: Confirm seat belt pre-tensioner activation using CONSULT only.
Center inner pillar	1. Check the center inner pillar on the collision side for damage (dents, cracks, deformation). 2. If damaged —REPAIR the center inner pillar.
Seat (if equipped with front side air bag)	If either the front LH or front RH side air bag modules has been deployed: REPLACE front seatback assembly on the deployed side.
Trim/headlining	1. Check for visible signs of damage (dents, cracks, deformation) of the interior trim on the collision side. 2. If damaged — REPLACE the damaged trim parts.
Door-mounted curtain air bag module LH	If the door-mounted curtain air bag module LH has been deployed: REPLACE the door finisher LH and door-mounted curtain air bag module. Install with new fasteners.
Door-mounted curtain air bag module RH	If the door-mounted curtain air bag module RH has been deployed: REPLACE the door finisher RH and door-mounted curtain air bag module. Install with new fasteners.
Occupant classification system (Passenger seat) (except Mexico)	1. Remove passenger seat assembly. 2. Check control unit case for dents, cracks or deformities. 3. Check connectors for damage and terminals for deformities. 4. Check seat frame and cushion pan for dents or deformities. 5. If no damage is found, reinstall seat with new fasteners. 6. If damaged — REPLACE seat cushion assembly with new fasteners. 7. Perform zero point reset function after front passenger seat is installed in the vehicle and all bolts are tightened to specification. Refer to <a href="#">SRC-42, "ZERO POINT RESET : Description"</a> .
Pop-up roll bar assemblies	If the pop-up roll bar has deployed: REPLACE pop-up roll bar assemblies and pop-up roll bar covers. Install with new fasteners.

FOR SIDE AND ROLLOVER COLLISION: When SRS is not activated in a collision

**CAUTION:**



# COLLISION DIAGNOSIS

## < BASIC INSPECTION >

**Due to varying models and option levels, not all parts listed in the chart below apply to all vehicles.**

### WORK PROCEDURE

1. Before performing any of the following steps, ensure that all vehicle body and structural repairs have been completed.
2. Check the SRS components and the related parts using the following table.
  - If the front seat back assembly is damaged, the front seat back assembly must be replaced.
  - If the door finisher assembly is damaged, the door finisher assembly and door-mounted curtain air bag module must be replaced.
3. Perform self-diagnosis using CONSULT and "AIR BAG" warning lamp. Refer to [SRC-15, "Diagnosis Description"](#) for details. Make sure entire SRS operates properly.
4. After the work is completed, perform self-diagnosis to check that no malfunction is detected. Refer to [SRC-15, "SRS Operation Check"](#).

### SRS INSPECTION (FOR SIDE AND ROLLOVER COLLISION)

Part	Inspection
Side curtain air bag module LH	If the side curtain air bag LH has NOT deployed: <ol style="list-style-type: none"> <li>1. Check for visible signs of damage (dents, tears, deformation) of the center pillar on the collision side.</li> <li>2. If damaged - Remove the side curtain air bag module LH.</li> <li>3. Check for visible signs of damage (tears etc.) of the side curtain air bag module LH.</li> <li>4. Check harness and connectors for damage, and terminals for deformities.</li> <li>5. If no damage is found, reinstall the side curtain air bag module LH with new fasteners.</li> <li>6. If damaged — REPLACE the side curtain air bag module LH with new fasteners.</li> </ol>
Side curtain air bag module RH	If the side curtain air bag RH has NOT deployed: <ol style="list-style-type: none"> <li>1. Check for visible signs of damage (dents, tears, deformation) of the center pillar on the collision side.</li> <li>2. If damaged - Remove the side curtain air bag module RH.</li> <li>3. Check for visible signs of damage (tears etc.) of the side curtain air bag module RH.</li> <li>4. Check harness and connectors for damage, and terminals for deformities.</li> <li>5. If no damage is found, reinstall the side curtain air bag module RH with new fasteners.</li> <li>6. If damaged — REPLACE the side curtain air bag module RH with new fasteners.</li> </ol>
Front side air bag module LH	If the front LH side air bag has NOT deployed: <ol style="list-style-type: none"> <li>1. Check for visible signs of damage (dents, tears, deformation) of the seat back on the collision side.</li> <li>2. Check harness and connectors for damage, and terminals for deformities.</li> <li>3. If damaged — REPLACE the front seatback assembly LH.</li> </ol>
Front side air bag module RH	If the front side air bag RH has NOT deployed: <ol style="list-style-type: none"> <li>1. Check for visible signs of damage (dents, tears, deformation) of the seat back on the collision side.</li> <li>2. Check harness and connectors for damage, and terminals for deformities.</li> <li>3. If damaged — REPLACE the front seatback assembly RH.</li> </ol>
Side air bag (satellite) sensor (LH or RH)	If none of the SRS components have been activated: <ol style="list-style-type: none"> <li>1. Remove the side air bag (satellite) sensor (LH or RH) on the collision side. Check harness connectors for damage, terminals for deformities, and harness for binding.</li> <li>2. Check for visible signs of damage (dents, cracks, deformation) of the side air bag (satellite) sensor (LH or RH).</li> <li>3. Install the side air bag (satellite) sensor (LH or RH) to check fit.</li> <li>4. If no damage is found, reinstall the side air bag (satellite) sensor (LH or RH) with new fasteners.</li> <li>5. If damaged — REPLACE the side air bag (satellite) sensor (LH or RH) with new fasteners.</li> </ol>
Door (satellite) sensor (LH or RH)	If none of the SRS components have been activated: <ol style="list-style-type: none"> <li>1. Remove the door (satellite) sensor (LH or RH) on the collision side. Check harness connectors for damage, terminals for deformities, and harness for binding.</li> <li>2. Check for visible signs of damage (dents, cracks, deformation) of the door (satellite) sensor (LH or RH).</li> <li>3. Install the door (satellite) sensor (LH or RH) to check fit.</li> <li>4. If no damage is found, reinstall the door (satellite) sensor (LH or RH) with new fasteners.</li> <li>5. If damaged — REPLACE the door (satellite) sensor (LH or RH) with new fasteners.</li> </ol>

# COLLISION DIAGNOSIS

## < BASIC INSPECTION >

Part	Inspection
Diagnosis sensor unit	<p>If none of the SRS components have been activated:</p> <ol style="list-style-type: none"> <li>1. Check case and bracket for dents, cracks or deformities.</li> <li>2. Check connectors for damage, and terminals for deformities.</li> <li>3. If no damage is found, reinstall the diagnosis sensor unit with new fasteners.</li> <li>4. If damaged — REPLACE the diagnosis sensor unit with new fasteners.</li> </ol>
Seat belt pre-tensioner assemblies (All applicable locations: buckle, retractor, lap outer)	<p>If the pre-tensioners have NOT been activated:</p> <ol style="list-style-type: none"> <li>1. Remove seat belt pre-tensioners. Check harness cover and connectors for damage, terminals for deformities, and harness for binding.</li> <li>2. Check belts for damage and anchors for loose mounting.</li> <li>3. Check retractor for smooth operation.</li> <li>4. Check seat belt adjuster for damage.</li> <li>5. Check for deformities of the center pillar inner.</li> <li>6. If no damage is found, reinstall seat belt pre-tensioner assembly with new fasteners.</li> <li>7. If damaged —REPLACE. Install the seat belt pre-tensioner assembly with new fasteners.</li> </ol>
Seat (with front side air bag)	<p>If the front LH or front RH side air bag modules have NOT deployed:</p> <ol style="list-style-type: none"> <li>1. Visually check the seat on the collision side.</li> <li>2. Remove the seat on the collision side and check the following for damage and deformities. <ul style="list-style-type: none"> <li>- Harness, connectors and terminals</li> <li>- Frame and recliner (for front and rear seat), and also adjuster and slides (for front seat)</li> </ul> </li> <li>3. If no damage is found, reinstall the seat.</li> <li>4. If damaged— REPLACE the damaged seat parts using new fasteners. If the front seat back is damaged, the front seat back assembly must be replaced.</li> </ol>
Center inner pillar	<ol style="list-style-type: none"> <li>1. Check the center inner pillar on the collision side for damage (dents, cracks, deformation, etc.).</li> <li>2. If damaged - REPAIR the center inner pillar.</li> </ol>
Trim/headlining	<ol style="list-style-type: none"> <li>1. Check for visible signs of damage (dents, cracks, deformation, etc.) of the interior trim on the collision side.</li> <li>2. If damaged - REPLACE the damaged trim parts.</li> </ol>
Door-mounted curtain air bag module LH	<p>If the door-mounted curtain air bag LH has NOT deployed:</p> <ol style="list-style-type: none"> <li>1. Check for visible signs of damage (dents, tears, deformation, etc.) of the door finisher on the collision side.</li> <li>2. If damaged - REPLACE the door finisher LH with new fasteners.</li> <li>3. Check for visible signs of damage (tears etc.) of the door-mounted curtain air bag module LH.</li> <li>4. Check harness and connectors for damage, and terminals for deformities.</li> <li>5. If no damage is found, reinstall door finisher.</li> </ol> <p><b>CAUTION:</b> <b>When removing door mounted curtain air bag module from door finisher, do not reuse door finisher.</b></p> <ol style="list-style-type: none"> <li>6. If damaged - REPLACE the door finisher LH and door-mounted curtain air bag module LH with new fasteners.</li> </ol>
Door-mounted curtain air bag module RH	<p>If the door-mounted curtain air bag RH has NOT deployed:</p> <ol style="list-style-type: none"> <li>1. Check for visible signs of damage (dents, tears, deformation, etc.) of the door finisher on the collision side.</li> <li>2. If damaged - REPLACE the door finisher RH with new fasteners.</li> <li>3. Check for visible signs of damage (tears etc.) of the door-mounted curtain air bag module RH.</li> <li>4. Check harness and connectors for damage, and terminals for deformities.</li> <li>5. If no damage is found, reinstall door finisher.</li> </ol> <p><b>CAUTION:</b> <b>When removing door mounted curtain air bag module from door finisher, do not reuse door finisher.</b></p> <ol style="list-style-type: none"> <li>6. If damaged - REPLACE the door finisher RH and door-mounted curtain air bag module RH with new fasteners.</li> </ol>

# COLLISION DIAGNOSIS

## < BASIC INSPECTION >

Part	Inspection	
Occupant classification system (Passenger seat) (except Mexico)	1. Remove passenger seat assembly.	A
	2. Check control unit case for dents, cracks or deformities.	
	3. Check connectors for damage and terminals for deformities.	
	4. Check seat frame and cushion pan for dents or deformities.	B
	5. If no damage is found, reinstall seat with new fasteners.	
	6. If damaged — REPLACE seat cushion assembly with new fasteners.	
	7. Perform zero point reset function after front passenger seat is installed in the vehicle and all bolts are tightened to specification. Refer to <a href="#">SRC-42, "ZERO POINT RESET : Description"</a> .	C
Pop-up roll bar	If the pop-up roll bar NOT deployed:	
	1. Check for visible signs of damage (dents, tears, deformation, etc.) of the pop-up roll bar.	D
	2. If damaged - REPLACE the pop-up roll bar with new fasteners.	
	3. Check harness and connectors for damage, and terminals for deformities.	
	4. If no damage is found, reinstall the pop-up roll bar with new fasteners.	E
	5. Check for visible signs of damage (dents, cracks, deformation, etc.) of the seatback support brace assembly.	
	6. If damaged - REPAIR the seatback support brace assembly.	

A

B

C

D

E

F

G

SR

I

J

K

L

M

N

O

P

# DRIVER AIR BAG MODULE

< REMOVAL AND INSTALLATION >

## REMOVAL AND INSTALLATION

### DRIVER AIR BAG MODULE

Exploded View

INFOID:000000011145552

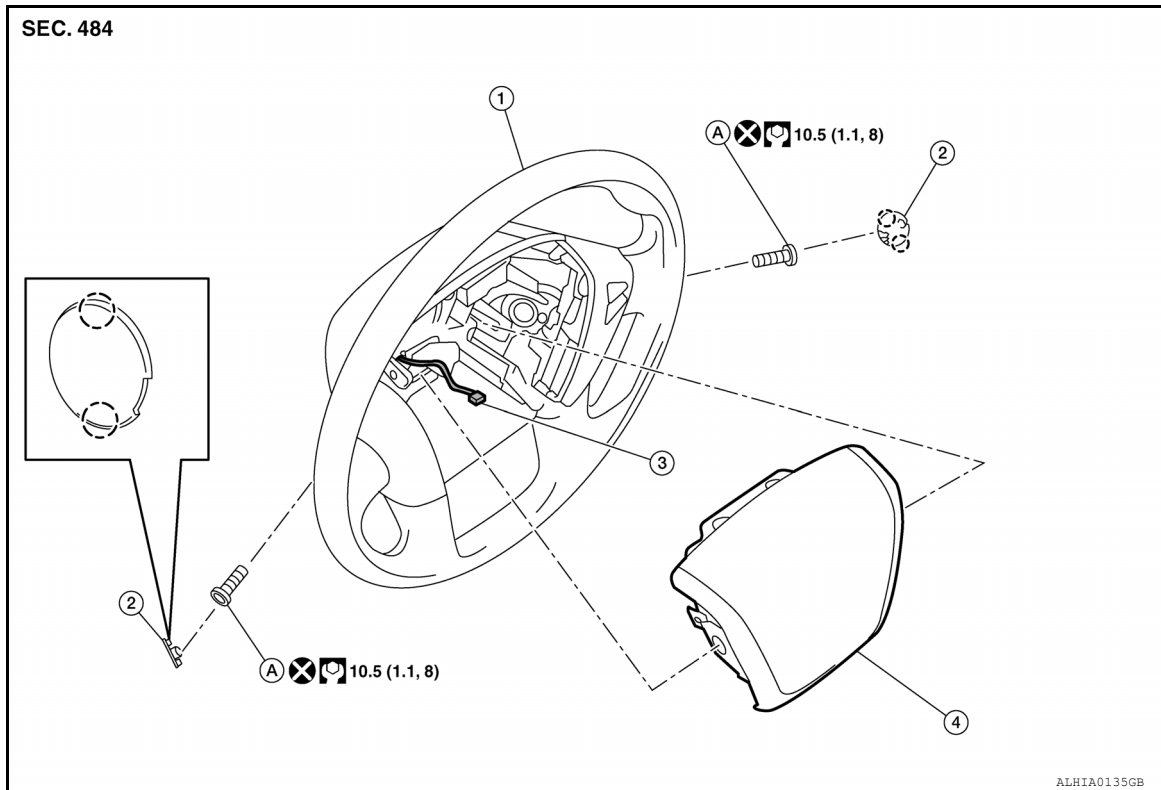

- |                          |                               |  |
|--------------------------|-------------------------------|--|
| 1. Steering wheel        | 2. Side lid (LH/RH)           | 3. Driver air bag module harness connector |
| 4. Driver air bag module | A. Driver air bag module bolt | Pawl                                       |

### Removal and Installation

INFOID:000000011145553

#### WARNING:

- Before servicing the SRS, turn ignition switch OFF, disconnect both battery terminals then wait at least three minutes.
- Always work from the side of air bag module. Do not work in front of it.
- Do not use air tools or electric tools for servicing.

#### REMOVAL

1. Disconnect negative and positive battery terminals, then wait at least three minutes. Refer to [PG-99, "Removal and Installation"](#).
2. Remove the side lids (LH/RH).
3. Remove the driver air bag module bolts (LH/RH).

#### CAUTION:

**Do not reuse the driver air bag module bolts.**

4. Lift the driver air bag module from the steering wheel.

# DRIVER AIR BAG MODULE

## < REMOVAL AND INSTALLATION >

5. Disconnect the harness connectors from the driver air bag module and horn.

**CAUTION:**

- For removing/installing the driver air bag module harness connector, insert a thin screwdriver wrapped in tape into the notch, then lift the lock and remove the harness connector as shown.
- Install the harness connector with the lock raised, and push the lock into the connector as shown.
- After installing the connector, check that the lock is pushed in securely.

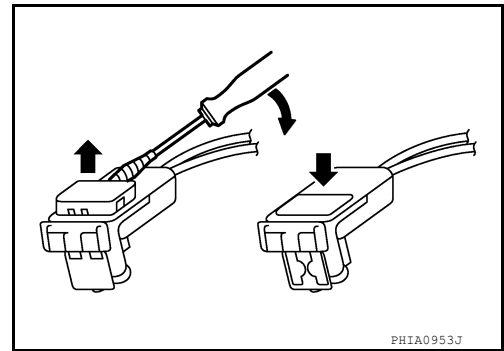

6. Remove the driver air bag module.

**CAUTION:**

- Always place the driver air bag module with pad side facing upward.
- ↔: Upward

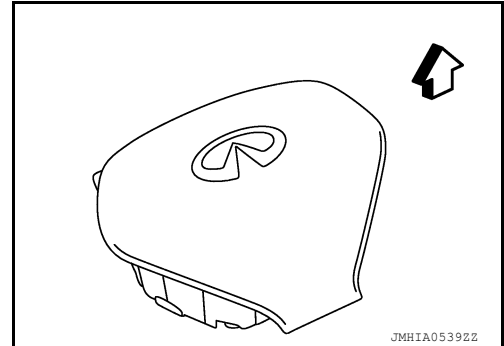

- Replace the driver air bag module if it has been dropped or sustained an impact.
- Do not strike the driver air bag module.



- Do not insert any foreign objects (screwdriver, etc.) into the driver air bag module.
- Do not disassemble the driver air bag module.
- Do not expose the driver air bag module to temperatures exceeding 90° C (194°F).
- Do not allow oil, grease, detergent or water to come in contact with the driver air bag module.

## INSTALLATION

Installation is in the reverse order of removal.

- Route the driver air bag module harness through the hook (A) so that the orange connector wire (1) and the yellow connector wire (2) are routed as shown, then attach the connectors.

**NOTE:**

For removal and installation of the direct-connect SRS connectors, refer to [SRC-9, "SRS Component Connectors"](#).

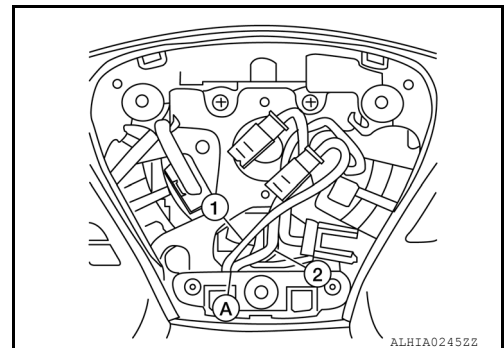

**CAUTION:**

- Do not reuse the driver air bag module bolts.
- If driver air bag module is being replaced due to deployment, the spiral cable must also be replaced. Refer to [SR-15, "Removal and Installation"](#).

A  
B  
C  
D  
E  
F  
G  
SR  
I  
J  
K  
L  
M  
N  
O  
P

## DRIVER AIR BAG MODULE

### < REMOVAL AND INSTALLATION >

---

- After installation is complete, check that no system malfunction is detected causing the air bag warning lamp to illuminate.
- If a malfunction is indicated by the air bag warning lamp after repair or replacement of the malfunctioning parts, perform the SRS final check. Refer to [SRC-17, "SRS Final Check"](#).

# SPIRAL CABLE

< REMOVAL AND INSTALLATION >

## SPIRAL CABLE

Exploded View

INFOID:000000011145554

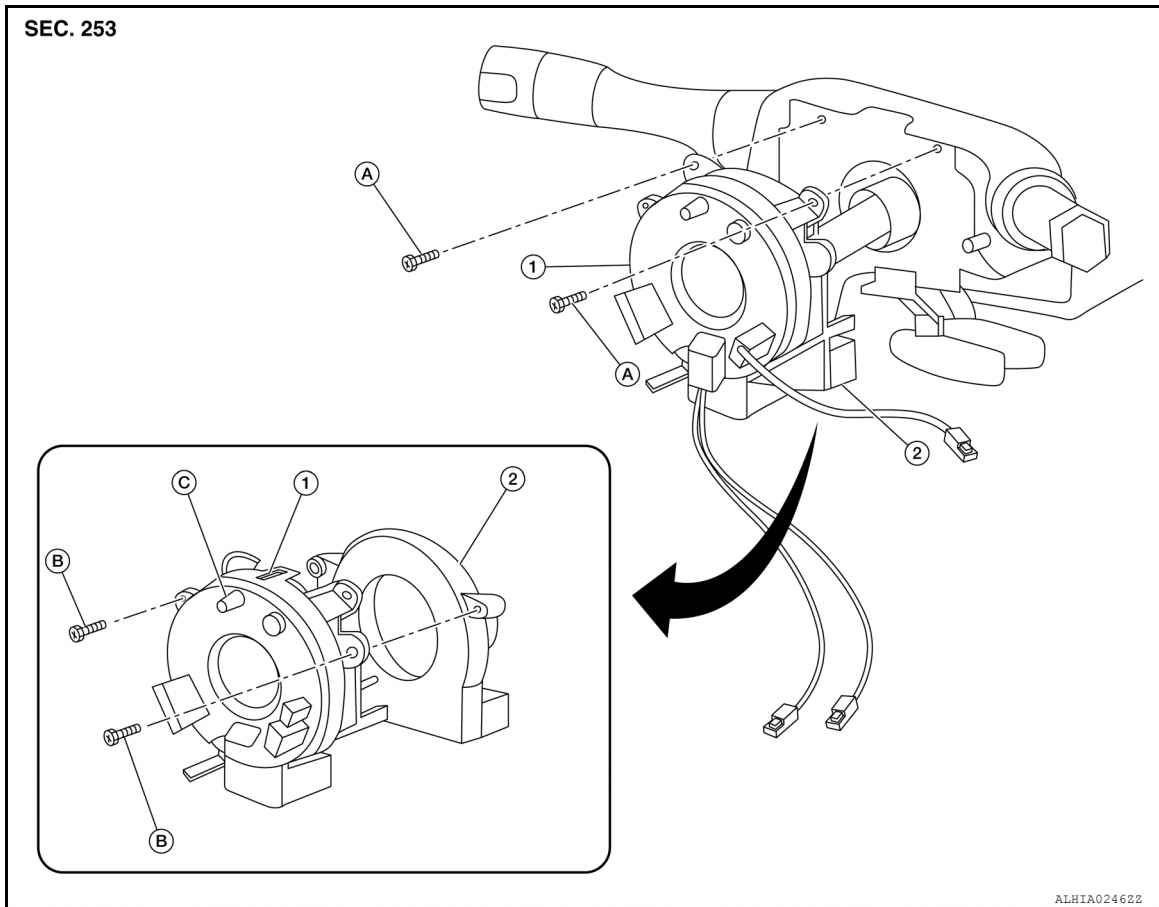

- |                                 |                          |                        |
|---------------------------------|--------------------------|------------------------|
| 1. Spiral cable                 | 2. Steering angle sensor | A. Spiral cable screws |
| B. Steering angle sensor screws | C. Locating pin          |                        |

## Removal and Installation

INFOID:000000011145555

### **WARNING:**

- Before servicing the SRS, turn ignition switch OFF, disconnect both battery terminals then wait at least three minutes.
- Do not use air tools or electric tools for servicing.

### REMOVAL

1. Disconnect negative and positive battery terminals, then wait at least three minutes. Refer to [PG-99. "Removal and Installation"](#).
2. Remove the steering wheel. Refer to [ST-47. "Removal and Installation"](#).
3. Remove the steering column upper and lower covers. Refer to [IP-17. "Removal and Installation"](#).

# SPIRAL CABLE

## < REMOVAL AND INSTALLATION >

4. Disconnect the harness connectors (A) from the spiral cable and the harness connector (B) from the steering angle sensor.

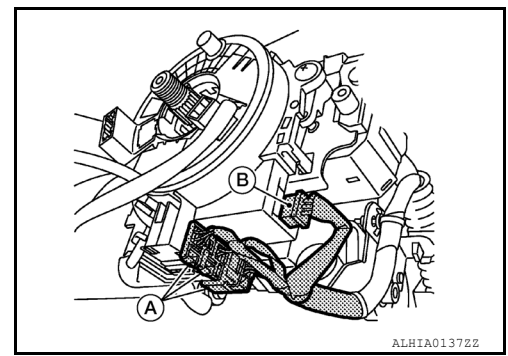

5. Remove screws (A), then release pawls and remove spiral cable and steering angle sensor (1) as an assembly.

 Pawl

**CAUTION:**

Do not turn the spiral cable quickly or beyond the limit number of turns (approximately 2.5 turns from the neutral position), this may cause the cable to snap.

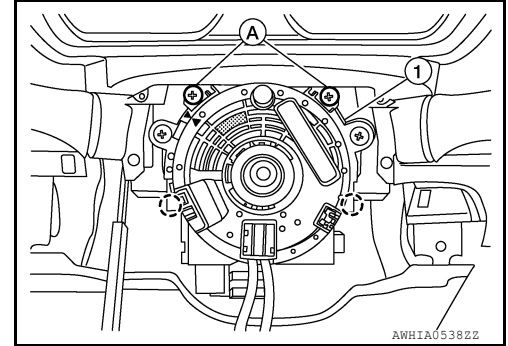

6. Remove screws (A), then release pawls (B) and separate the steering angle sensor (2) from spiral cable (1).

**CAUTION:**

Do not reuse steering angle sensor.

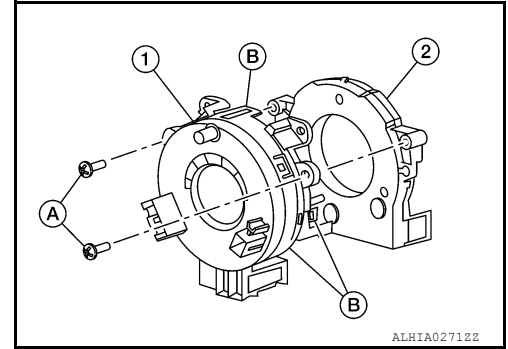

**CAUTION:**

- Do not strike or drop the spiral cable.
- Replace the spiral cable if it has been dropped or sustained an impact.
- Do not disassemble the spiral cable.
- Do not allow oil, grease, detergent or water to come in contact with the spiral cable.



## INSTALLATION

Installation is in the reverse order of removal.

- The turn signal lever must be in the neutral position for spiral cable installation.



## SPIRAL CABLE

### < REMOVAL AND INSTALLATION >

- Set the spiral cable neutral position by carefully turning the spiral cable clockwise to the end position. Turn the spiral cable counter-clockwise 2.5 turns stopping when the locating pin (A) is at the top most position, the triangles (C) are pointing at each other as shown and the clear window (B) appears white.

#### NOTE:

- If a new part is installed, the neutral position is already set with a stopper in place and should not be adjusted after the stopper is removed. Make sure the stopper clip is removed after the spiral cable/steering angle sensor assembly is installed but before the steering wheel is installed.
- During steering wheel installation, make sure the locating pin hole (D) is aligned with the locating pin (A) of the spiral cable.
- Perform the neutral position adjustment for the steering angle sensor. Refer to [BRC-60, "Work Procedure"](#).

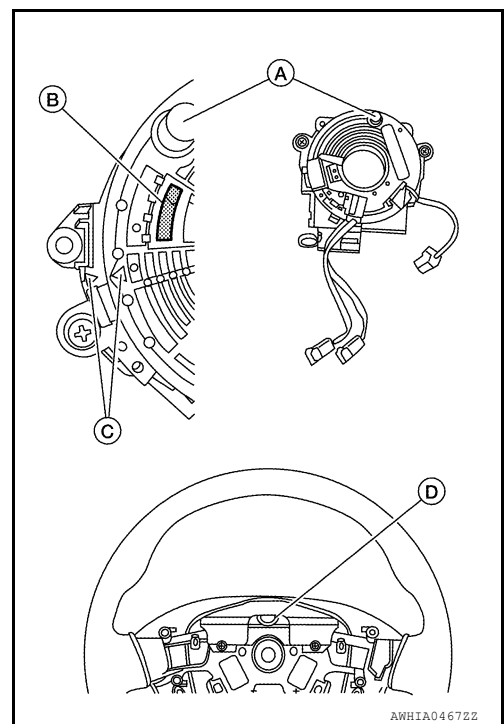

#### CAUTION:

- The spiral cable may snap during steering operation if the spiral cable is installed in an improper position.
- Do not overturn the spiral cable or go beyond the maximum number of turns allowed. This will cause the cable to snap.
- The turn signal lever must be in the neutral position for spiral cable installation.
- Do not apply lubricant to the spiral cable.
- Do not allow oil, grease, detergent or water to come in contact with the spiral cable.
- After installation is completed, check that no system malfunction is detected using CONSULT or the air bag warning lamp.
- If no malfunction is detected using CONSULT or the air bag warning lamp after repair or replacement of the malfunctioning parts, perform the SRS final check. Refer to [SRC-17, "SRS Final Check"](#).

# FRONT PASSENGER AIR BAG MODULE

< REMOVAL AND INSTALLATION >

## FRONT PASSENGER AIR BAG MODULE

Exploded View

INFOID:000000011145556

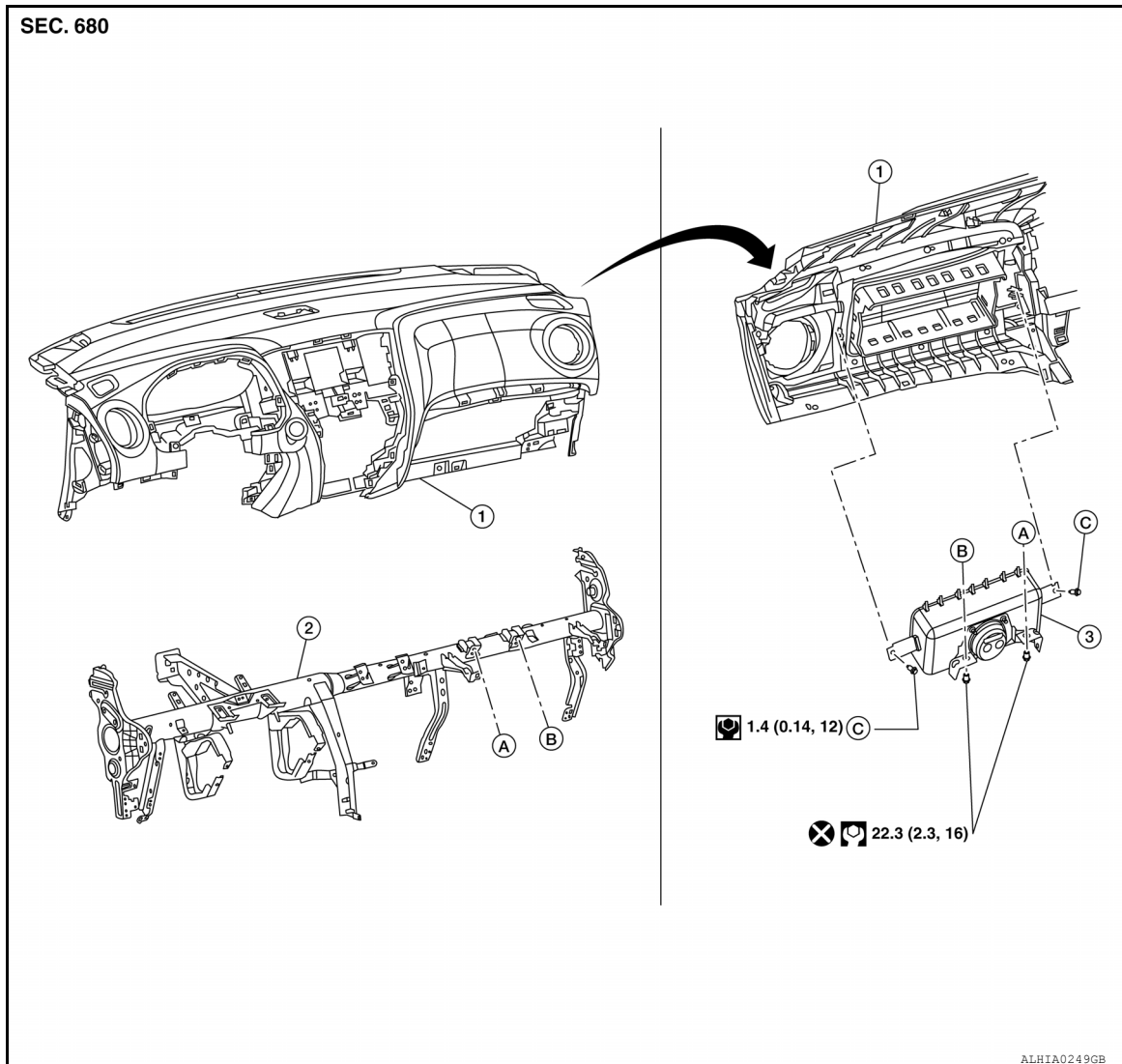

- |   |   |  |
|---|---|--|
| 1. Instrument panel assembly  | 2. Steering member assembly   | 3. Front passenger air bag module        |
| A. Front passenger air bag module bolt to steering member assembly (LH) | B. Front passenger air bag module bolt to steering member assembly (RH) | C. Front passenger air bag module screws |

### Removal and Installation

INFOID:000000011145557

#### **WARNING:**

- Before servicing the SRS, turn ignition switch OFF, disconnect both battery terminals then wait at least three minutes.
- Always work from the side of air bag module. Do not work in front of it.
- Do not use air tools or electric tools for servicing.

#### REMOVAL

1. Disconnect negative and positive battery terminals, then wait at least three minutes. Refer to [PG-99. "Removal and Installation"](#).
2. Remove the instrument panel assembly. Refer to [IP-15. "Removal and Installation"](#).
3. Remove the front passenger air bag module screws.

# FRONT PASSENGER AIR BAG MODULE

## < REMOVAL AND INSTALLATION >

4. Disconnect the front passenger air bag module pawls using a suitable tool (A) as shown.
5. Lift up on the front passenger air bag module to remove the front passenger air bag module as shown.

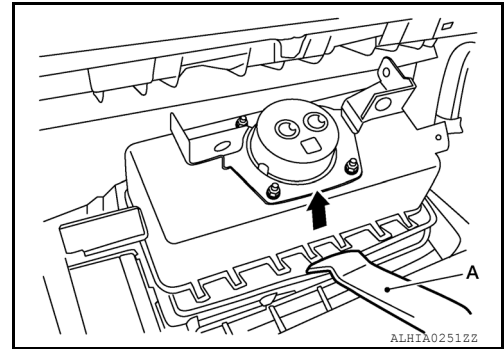

### CAUTION:

- Always place the front passenger air bag module with the pad side facing upward as shown.  
⇐: Upward

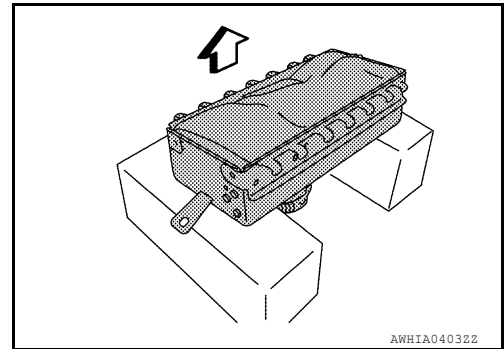

- Replace the front passenger air bag module if it has been dropped or sustained an impact.
- Do not strike the front passenger air bag module.



- Do not insert any foreign objects (screwdriver, etc.) into the front passenger air bag module.
- Do not disassemble the front passenger air bag module.
- Do not expose the front passenger air bag module to temperatures exceeding 90 °C (194 °F).
- Do not allow oil, grease, detergent, or water to come in contact with the front passenger air bag module.

## INSTALLATION

Installation is in the reverse order of removal.

### CAUTION:

- Do not reuse the front passenger air bag module bolts.
- Do not damage the front passenger air bag module harness during installation.
- After installation is complete, check that no system malfunction is detected causing the air bag warning lamp to illuminate.
- If a malfunction is indicated by the air bag warning lamp after repair or replacement of the malfunctioning parts, perform the SRS final check. Refer to [SRC-17, "SRS Final Check"](#).

A  
B  
C  
D  
E  
F  
G  
SR  
I  
J  
K  
L  
M  
N  
O  
P

# SIDE CURTAIN AIR BAG MODULE

< REMOVAL AND INSTALLATION >

## SIDE CURTAIN AIR BAG MODULE

Exploded View

INFOID:000000011145558

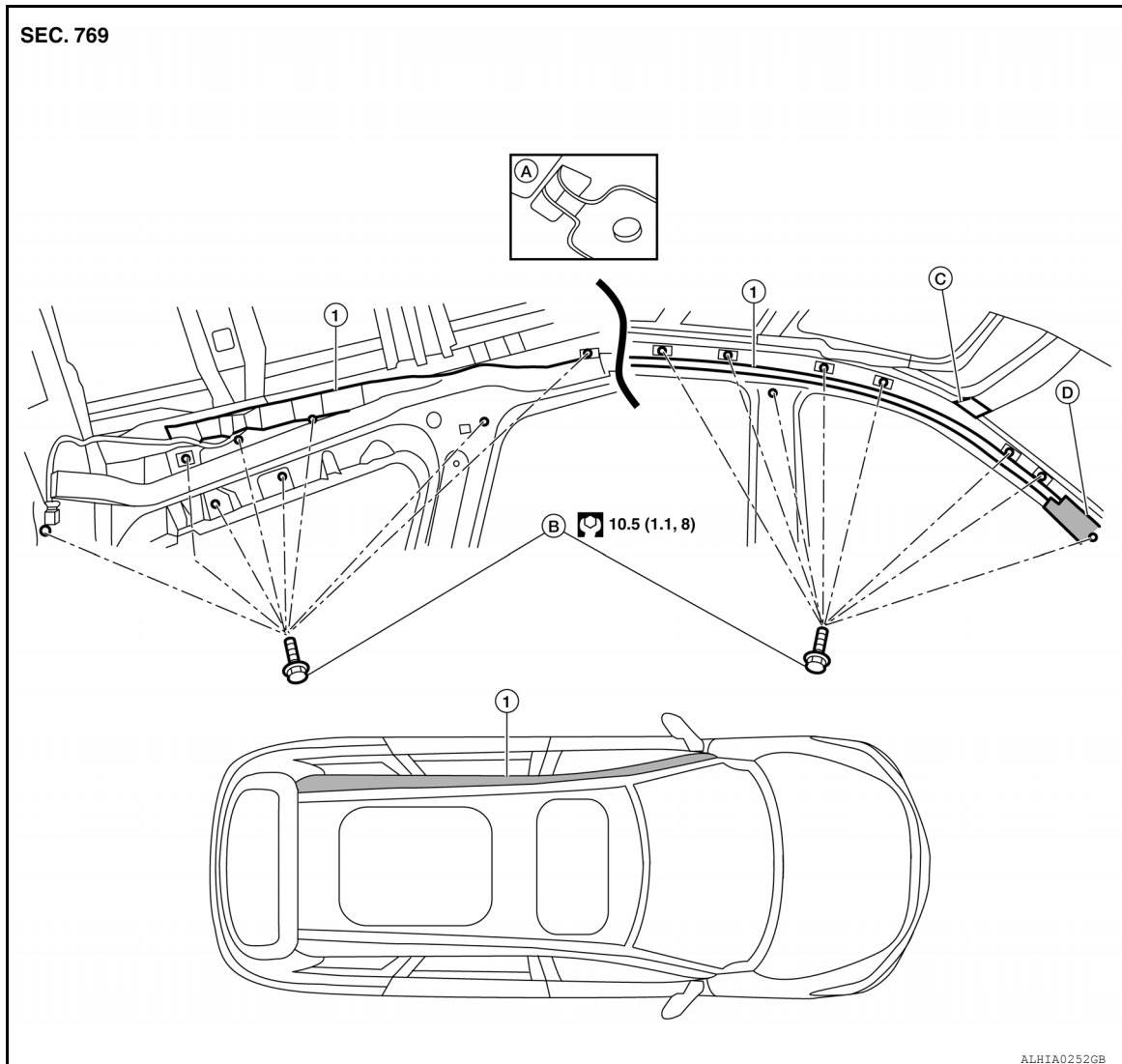

1. Side curtain air bag module    A. Side curtain air bag module bracket    B. Side curtain air bag module bolts supporting hook  
C. Clip    D. Front tether

### NOTE:

LH side shown, RH side similar.

### Removal and Installation

INFOID:000000011145559

### WARNING:

- Before servicing the SRS, turn ignition switch OFF, disconnect both battery terminals then wait at least three minutes.
- Always work from the side of air bag module. Do not work in front of it.
- Do not use air tools or electric tools for servicing.

### REMOVAL

1. Disconnect negative and positive battery terminals, then wait at least three minutes. Refer to [PG-99, "Removal and Installation"](#).
2. Remove the headlining. Refer to [INT-27, "Removal and Installation"](#).

# SIDE CURTAIN AIR BAG MODULE

## < REMOVAL AND INSTALLATION >

3. Disconnect the harness connector from the side curtain air bag module.

**CAUTION:**

- For removing/installing the side curtain air bag module harness connector, insert a thin screwdriver wrapped in tape into the notch, lift the lock and remove the harness connector as shown.
- Install the harness connector with the lock raised, and push the lock into the harness connector as shown.
- After installing the harness connector, check that the lock is pushed in securely.

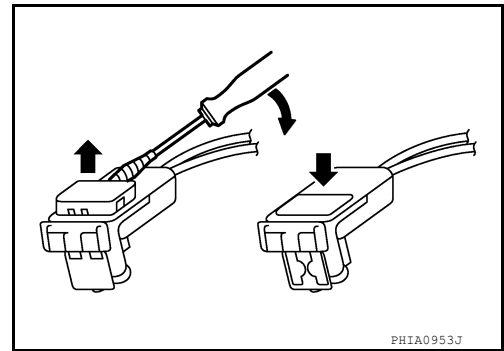

4. Remove the side curtain air bag module clip (A) located at the top of the front pillar (1) as shown.

⇐: Front

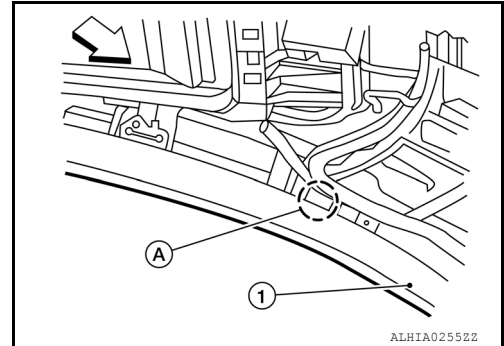

5. Remove the side curtain air bag module bolts.  
6. Disconnect the side curtain air bag module bracket supporting hooks and remove the side curtain air bag module.

**CAUTION:**

- Replace the side curtain air bag module if it has been dropped or sustained an impact.
- Do not strike the side curtain air bag module.
- Do not insert any foreign objects (screwdriver, etc.) into the side curtain air bag module.
- Do not disassemble the side curtain air bag module.
- Do not expose the side curtain air bag module to temperatures exceeding 90 °C (194 °F).
- Do not allow oil, grease, detergent or water to come in contact with the side curtain air bag module.

## INSTALLATION

Installation is in the reverse order of removal.

**CAUTION:**

- Do not damage the harness while installing the side curtain air bag module.
- Make sure that the side curtain air bag module bracket supporting hooks are securely seated into the body slots before releasing the side curtain air bag module during installation to avoid damaging the side curtain air bag module.
- Make sure the side curtain air bag module front tether (1) is routed below the front pillar finisher attachment point (A) as shown.

⇐: Front

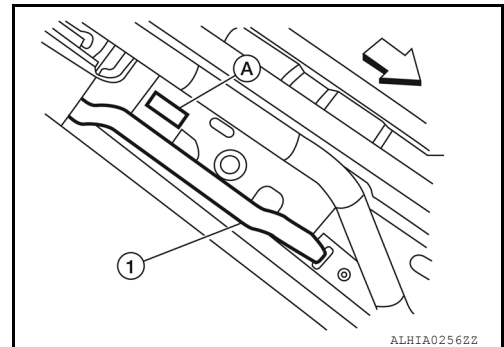

- After installation is complete, check that no system malfunction is detected causing the air bag warning lamp to illuminate.
- If a malfunction is indicated by the air bag warning lamp after repair or replacement of the malfunctioning parts, perform the SRS final check. Refer to [SRC-17, "SRS Final Check"](#).

## FRONT SIDE AIR BAG MODULE

< REMOVAL AND INSTALLATION >

---

### FRONT SIDE AIR BAG MODULE

#### Removal and Installation

INFOID:000000011145560

The front side air bag module is part of the front seatback. For removal and installation of the front seatback, refer to [SE-151, "Seatback"](#).

# CRASH ZONE SENSOR

< REMOVAL AND INSTALLATION >

## CRASH ZONE SENSOR

### Exploded View

INFOID:000000011145561

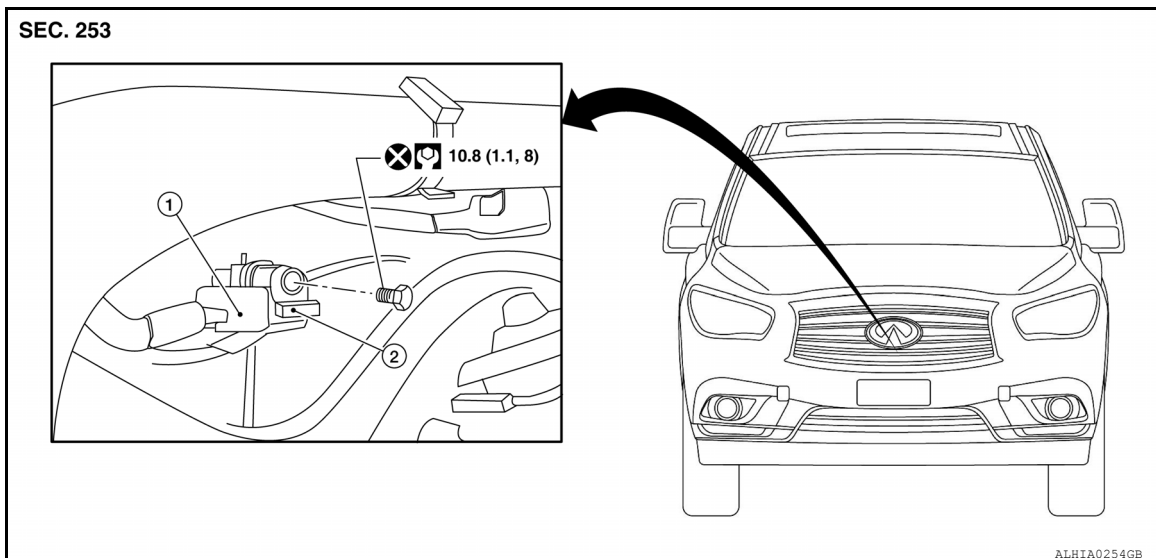

1. Crash zone sensor harness connector      2. Crash zone sensor

### Removal and Installation

INFOID:000000011145562

#### **WARNING:**

- Before servicing the SRS, turn ignition switch OFF, disconnect both battery terminals then wait at least three minutes.
- Do not use air tools or electric tools for servicing.

#### REMOVAL

1. Disconnect negative and positive battery terminals, then wait at least three minutes. Refer to [PG-99, "Removal and Installation"](#).
2. Remove the front air duct. Refer to [EM-24, "Exploded View"](#).
3. Disconnect the harness connector from the crash zone sensor.
4. Remove the crash zone sensor bolt.

#### **CAUTION:**

**Do not reuse the crash zone sensor bolt.**

5. Remove the crash zone sensor.

#### **CAUTION:**

- Replace the crash zone sensor if it has been dropped or sustained an impact.
- Do not strike the crash zone sensor.
- Replace the crash zone sensor if either the driver air bag or the front passenger air bag has been deployed.

#### INSTALLATION

Installation is in the reverse order of removal.

#### **CAUTION:**

- Do not reuse the crash zone sensor bolt.
- Do not damage the harness connector during installation.
- After installation is complete, check that no system malfunction is detected causing the air bag warning lamp to illuminate.
- If a malfunction is indicated by the air bag warning lamp after repair or replacement of the malfunctioning parts, perform the SRS final check. Refer to [SRC-17, "SRS Final Check"](#).

# SATELLITE SENSOR

< REMOVAL AND INSTALLATION >

## SATELLITE SENSOR

Exploded View

INFOID:000000011145563

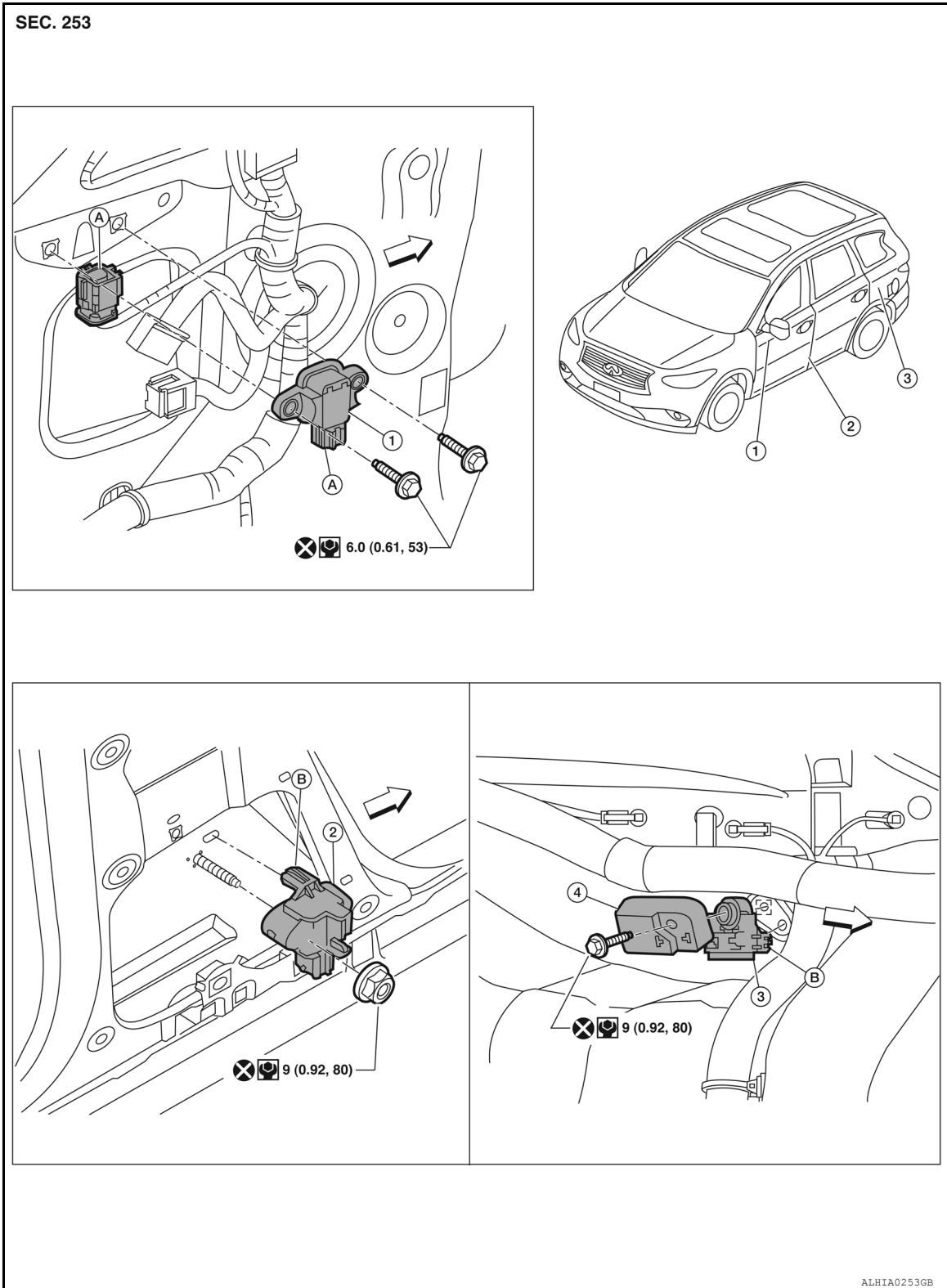

1. Front door satellite sensor (LH/RH) (except Mexico)
2. Front side air bag satellite sensor (LH/RH)
3. Rear side air bag satellite sensor (LH/RH)



# SATELLITE SENSOR

## < REMOVAL AND INSTALLATION >

4. Rear side air bag satellite sensor cover (LH/RH)      A. Front door satellite sensor harness connector      B. Pawl
- ⇐ Front

### NOTE:

LH side shown, RH side similar.

## Removal and Installation

INFOID:000000011145564

### WARNING:

- Before servicing the SRS, turn ignition switch OFF, disconnect both battery terminals then wait at least three minutes.
- Do not use air tools or electric tools for servicing.

## FRONT SIDE AIR BAG SATELLITE SENSOR

### Removal

1. Disconnect negative and positive battery terminals, then wait at least three minutes. Refer to [PG-99, "Removal and Installation"](#).
2. Remove the front seat belt retractor. Refer to [SB-8, "Front Seat Belt"](#).
3. Remove the front side air bag satellite sensor nut.

### CAUTION:

**Do not reuse the front side air bag satellite sensor nut.**

4. Disconnect the harness connector from the front side air bag satellite sensor.
5. Remove the front side air bag satellite sensor.

### CAUTION:

- Replace the front side air bag satellite sensor if it has been dropped or sustained an impact.
- Do not strike the front side air bag satellite sensor.

### Installation

Installation is in the reverse order of removal.

- Position the front side air bag satellite sensor using the pawl before tightening the nut to specification.

### CAUTION:

- Do not reuse the front side air bag satellite sensor nut.
- Do not damage the harness connector during installation.
- After installation is complete, check that no system malfunction is detected causing the air bag warning lamp to illuminate.
- If a malfunction is indicated by the air bag warning lamp after repair or replacement of the malfunctioning parts, perform the SRS final check. Refer to [SRC-17, "SRS Final Check"](#).

## REAR SIDE AIR BAG SATELLITE SENSOR

### Removal

1. Disconnect negative and positive battery terminals, then wait at least three minutes. Refer to [PG-99, "Removal and Installation"](#).
2. Remove the luggage side lower finisher. Refer to [INT-31, "LUGGAGE SIDE LOWER FINISHER : Removal and Installation"](#).
3. Remove the rear side air bag satellite sensor bolt.

### CAUTION:

**Do not reuse the rear side air bag satellite sensor bolt.**

4. Disconnect the harness connector from the rear side air bag satellite sensor.
5. Remove the rear side air bag satellite sensor.

### CAUTION:

- Replace the rear side air bag satellite sensor if it has been dropped or sustained an impact.
- Do not strike the rear side air bag satellite sensor.

### Installation

Installation is in the reverse order of removal.

- Position the rear side air bag satellite sensor using the pawl before tightening the bolt to specification.

### CAUTION:

- Do not reuse the rear side air bag satellite sensor bolt.

# SATELLITE SENSOR

## < REMOVAL AND INSTALLATION >

---

- Do not damage the harness connector during installation.
- After installation is complete, check that no system malfunction is detected causing the air bag warning lamp to illuminate.
- If a malfunction is indicated by the air bag warning lamp after repair or replacement of the malfunctioning parts, perform the SRS final check. Refer to [SRC-17, "SRS Final Check"](#).

### FRONT DOOR SATELLITE SENSOR

#### Removal

1. Disconnect negative and positive battery terminals, then wait at least three minutes. Refer to [PG-99, "Removal and Installation"](#).
2. Remove the front door finisher. Refer to [INT-15, "Removal and Installation"](#).
3. Remove the front door satellite sensor bolts.  
**CAUTION:**  
**Do not reuse the front door satellite sensor bolts.**
4. Disconnect the harness connector from the front door satellite sensor.
5. Remove the front door satellite sensor.  
**CAUTION:**
  - Replace the front door satellite sensor if it has been dropped or sustained an impact.
  - Do not strike the front door satellite sensor.

#### Installation

Installation is in the reverse order of removal.

#### **CAUTION:**

- Do not reuse the front door satellite sensor bolts.
- Do not damage the harness connector during installation.
- After installation is complete, check that no system malfunction is detected causing the air bag warning lamp to illuminate.
- If a malfunction is indicated by the air bag warning lamp after repair or replacement of the malfunctioning parts, perform the SRS final check. Refer to [SRC-17, "SRS Final Check"](#).

# AIR BAG DIAGNOSIS SENSOR UNIT

< REMOVAL AND INSTALLATION >

## AIR BAG DIAGNOSIS SENSOR UNIT

Exploded View

INFOID:000000011145565

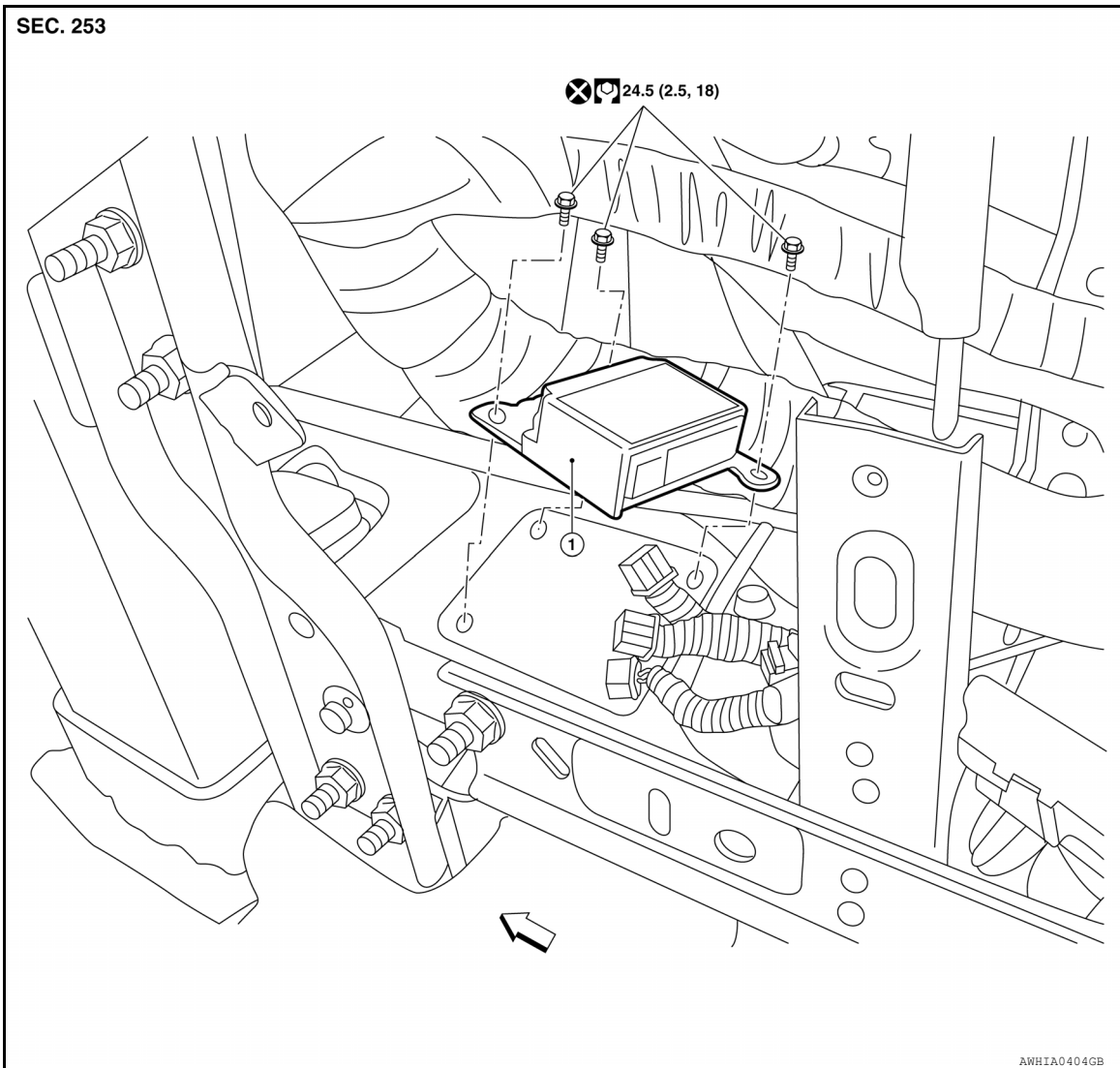

1. Air bag diagnosis sensor unit

⇐ Front

### Removal and Installation

INFOID:000000011145566

#### **WARNING:**

- Before servicing the SRS, turn ignition switch OFF, disconnect both battery terminals then wait at least three minutes.
- Before disconnecting the air bag diagnosis sensor unit harness connectors, be sure to disconnect each harness connector of the side curtain air bag modules, front seat belt pre-tensioner, and front side air bag module, to prevent accidental air bag deployment by static electricity and seat belt pre-tensioner operation.
- Do not use the air tools or electric tools for servicing.
- When replacing the air bag diagnosis sensor unit, always check with the parts department for the latest parts information. Installing an incorrect air bag diagnosis sensor unit may or may not cause the air bag warning lamp to illuminate and may cause incorrect deployment of the supplemental air bags and seat belt pre-tensioners in a collision resulting in serious personal injury or death.

#### REMOVAL

A

B

C

D

E

F

G

SR

I

J

K

L

M

N

O

P

## AIR BAG DIAGNOSIS SENSOR UNIT

### < REMOVAL AND INSTALLATION >

1. Always check the air bag diagnosis sensor unit ECU discriminated number (identification number) or part number using CONSULT.
2. Disconnect negative and positive battery terminals, then wait at least three minutes. Refer to [PG-99, "Removal and Installation"](#).
3. Remove the center console assembly. Refer to [IP-18, "Removal and Installation"](#).
4. Disconnect the harness connectors for the following SRS components: [SR-20, "Removal and Installation"](#) (side curtain air bag modules), [SR-29, "Removal and Installation"](#) (front seat belt pre-tensioner) and [SR-22, "Removal and Installation"](#) (front side air bag module).
5. Remove the air bag diagnosis sensor unit bolts.
6. Disconnect the harness connectors from the air bag diagnosis sensor unit and remove.

#### **CAUTION:**

- Replace the air bag diagnosis sensor unit if it has been dropped or sustained an impact.
- Do not strike the air bag diagnosis sensor unit.

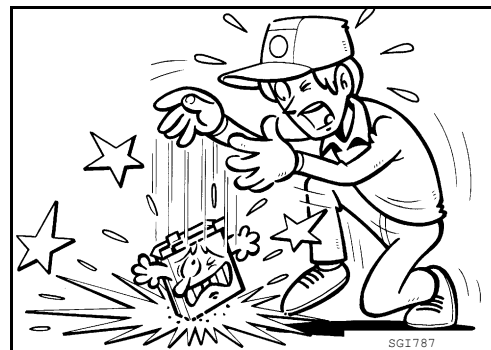

- Replace the air bag diagnosis sensor unit if any SRS air bag has been deployed or if any front seat belt pre-tensioner has been deployed.

### INSTALLATION

Installation is in the reverse order of removal.

#### **CAUTION:**

- Do not reuse the air bag diagnosis sensor unit bolts.
- The air bag diagnosis sensor unit must always be installed with the label arrow mark "←" pointing toward the front of the vehicle for proper operation.
- Do not damage the air bag diagnosis sensor unit harness connectors during installation.
- After installation is complete, check that no system malfunction is detected causing the air bag warning lamp to illuminate.
- If a malfunction is indicated by the air bag warning lamp after repair or replacement of the malfunctioning parts, perform the SRS final check. Refer to [SRC-17, "SRS Final Check"](#).
- After replacing the air bag diagnosis sensor unit, confirm using CONSULT that the ECU discriminated number (identification number) or part number of the new replacement air bag diagnosis sensor unit matches the ECU discriminated number (identification number) or part number of the replaced (old) air bag diagnosis sensor unit.

#### **NOTE:**

If the ECU discriminated number or part number of the new replacement air bag diagnosis sensor unit differs from the ECU discriminated number or part number of the replaced air bag diagnosis sensor unit, reconfirm the parts information and verify that the correct air bag diagnosis sensor unit was installed.

# SEAT BELT PRE-TENSIONER

< REMOVAL AND INSTALLATION >

## SEAT BELT PRE-TENSIONER

### Removal and Installation

INFOID:000000011145567

The front seat belt has two pre-tensioners. One pre-tensioner is part of the seat belt retractor and the other is a lap belt pre-tensioner. For removal and installation refer to [SB-8. "Front Seat Belt"](#) (seat belt retractor and lap belt pretensioner).

- A
- B
- C
- D
- E
- F
- G
- SR**
- I
- J
- K
- L
- M
- N
- O
- P

## FRONT SEAT BELT BUCKLE SWITCH

< REMOVAL AND INSTALLATION >

---

### FRONT SEAT BELT BUCKLE SWITCH

#### Removal and Installation

INFOID:000000011145568

The front seat belt buckle switch is part of the front seat belt buckle. For removal and installation of the front seat belt buckle, refer to [SB-8. "Front Seat Belt"](#).

# OCCUPANT CLASSIFICATION SYSTEM

< REMOVAL AND INSTALLATION >

## OCCUPANT CLASSIFICATION SYSTEM

### Removal and Installation

INFOID:000000011145569

#### OCCUPANT CLASSIFICATION SYSTEM CONTROL UNIT

##### **WARNING:**

- Before servicing the SRS, turn ignition switch OFF, disconnect both battery terminals then wait at least three minutes.
- Do not use air tools or electric tools for servicing.

##### Removal

1. Remove front passenger seat assembly. Refer to [SE-114, "Removal and Installation"](#).
2. Remove occupant classification system control unit bolts.
3. Disconnect the harness connector from the occupant classification system control unit.
4. Remove occupant classification system control unit.

##### **CAUTION:**

- Replace the occupant classification control unit if it has been dropped or sustained an impact.
- Do not strike the occupant classification control unit.

##### Installation

Installation is in the reverse order of removal.

##### **CAUTION:**

- Do not damage the harness connector during installation.
- After installation is complete, check that no system malfunction is detected causing the air bag warning lamp to illuminate.
- If a malfunction is indicated by the air bag warning lamp after repair or replacement of the malfunctioning parts, perform the SRS final check. Refer to [SRC-17, "SRS Final Check"](#).

#### OCCUPANT CLASSIFICATION SYSTEM SENSORS

##### Removal

1. Remove front passenger seat. Refer to [SE-114, "Removal and Installation"](#).
2. Remove screws and slide finisher outer (LH).
3. Remove nuts (A) and bolt (B), then disconnect harness connectors from occupant classification sensors and remove seat track (LH) from seat frame.

##### **CAUTION:**

Do not reuse nut. Replace with new part during installation.

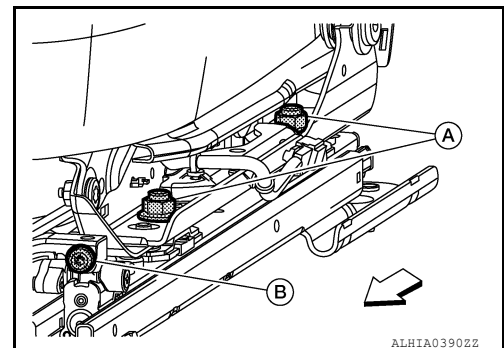

4. Remove nuts (A) from occupant classification sensor and remove.

##### **CAUTION:**

Do not reuse nut. Replace with new part during installation.

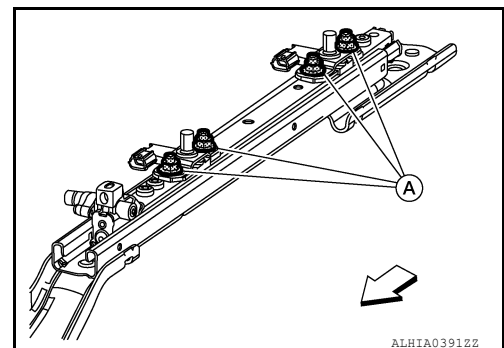

##### Installation

Installation is in the reverse order of removal.

A  
B  
C  
D  
E  
F  
G  
SR  
I  
J  
K  
L  
M  
N  
O  
P

# OCCUPANT CLASSIFICATION SYSTEM

## < REMOVAL AND INSTALLATION >

### CAUTION:

- Do not reuse nuts. Replace with new part during installation.
- Tighten the nuts to specification.

Seat track nuts (A)

45 N·m (4.6 kg-m, 33 ft-lb)

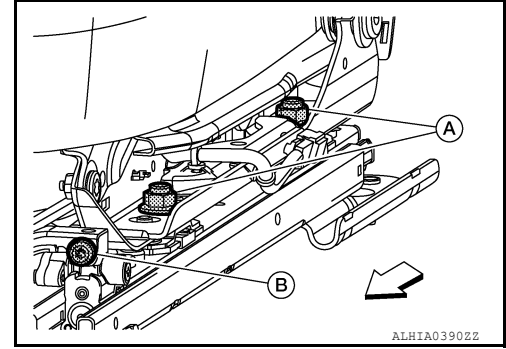

- Tighten the nut to specification.

Occupant classification sensor nut (A)

22 N·m (2.2 kg-m, 16 ft-lb)

