

SECTION PCS

POWER CONTROL SYSTEM

A
B
C
D
E
F
G
H
I
J
K
L
PCS
N
O
P

CONTENTS

IPDM E/R	Wiring Diagram	21
PRECAUTION	DTC/CIRCUIT DIAGNOSIS	27
PRECAUTIONS	U1000 CAN COMM CIRCUIT	27
Precaution for Supplemental Restraint System (SRS) "AIR BAG" and "SEAT BELT PRE-TENSIONER"	Description	27
	DTC Logic	27
	Diagnosis Procedure	27
SYSTEM DESCRIPTION	U1010 CONTROL UNIT (CAN)	28
COMPONENT PARTS	DTC Logic	28
Component Parts Location	Diagnosis Procedure	28
SYSTEM	B2098 IGNITION RELAY ON STUCK	29
RELAY CONTROL SYSTEM	Description	29
RELAY CONTROL SYSTEM : System Diagram	DTC Logic	29
RELAY CONTROL SYSTEM : System Description	Diagnosis Procedure	29
POWER CONSUMPTION CONTROL SYSTEM	B2099 IGNITION RELAY OFF STUCK	30
POWER CONSUMPTION CONTROL SYSTEM : System Diagram	Description	30
POWER CONSUMPTION CONTROL SYSTEM : System Description	DTC Logic	30
	Diagnosis Procedure	30
DIAGNOSIS SYSTEM (IPDM E/R)	POWER SUPPLY AND GROUND CIRCUIT	31
Diagnosis Description	Diagnosis Procedure	31
CONSULT Function (IPDM E/R)	REMOVAL AND INSTALLATION	32
ECU DIAGNOSIS INFORMATION	IPDM E/R (INTELLIGENT POWER DISTRIBUTION MODULE ENGINE ROOM)	32
IPDM E/R (INTELLIGENT POWER DISTRIBUTION MODULE ENGINE ROOM)	Removal and Installation	32
Reference Value	POWER DISTRIBUTION SYSTEM	
Fail Safe	PRECAUTION	33
DTC Index	PRECAUTIONS	33
WIRING DIAGRAM	Precaution for Supplemental Restraint System (SRS) "AIR BAG" and "SEAT BELT PRE-TENSIONER"	33
IPDM E/R (INTELLIGENT POWER DISTRIBUTION MODULE ENGINE ROOM)	Precaution for Work	33
	PREPARATION	34

PREPARATION	34	B2615 BLOWER RELAY CIRCUIT	64
Special Service Tool	34	DTC Logic	64
SYSTEM DESCRIPTION	35	Diagnosis Procedure	64
COMPONENT PARTS	35	Component Inspection (Relay)	65
Component Parts Location	35	B2616 IGNITION RELAY CIRCUIT	66
SYSTEM	36	DTC Logic	66
POWER DISTRIBUTION SYSTEM	36	Diagnosis Procedure	66
POWER DISTRIBUTION SYSTEM : System Dia-		Component Inspection (Relay)	67
gram	36	B2618 BCM	68
POWER DISTRIBUTION SYSTEM : System De-		DTC Logic	68
scription	36	Diagnosis Procedure	68
DIAGNOSIS SYSTEM (BCM)	38	B261A PUSH-BUTTON IGNITION SWITCH	70
COMMON ITEM	38	DTC Logic	70
COMMON ITEM : CONSULT Function (BCM -		Diagnosis Procedure	70
COMMON ITEM)	38	B26F1 IGNITION RELAY	72
INTELLIGENT KEY	39	DTC Logic	72
INTELLIGENT KEY : CONSULT Function (BCM -		Diagnosis Procedure	72
INTELLIGENT KEY)	39	B26F2 IGNITION RELAY	74
ECU DIAGNOSIS INFORMATION	43	DTC Logic	74
BCM, IPDM E/R	43	Diagnosis Procedure	74
List of ECU Reference	43	B26F6 BCM	76
WIRING DIAGRAM	44	DTC Logic	76
POWER DISTRIBUTION SYSTEM	44	Diagnosis Procedure	76
Wiring Diagram	44	PUSH-BUTTON IGNITION SWITCH	78
BASIC INSPECTION	55	Component Function Check	78
DIAGNOSIS AND REPAIR WORK FLOW	55	Diagnosis Procedure	78
Work Flow	55	Component Inspection	79
DTC/CIRCUIT DIAGNOSIS	58	POWER SUPPLY AND GROUND CIRCUIT	81
U1000 CAN COMM CIRCUIT	58	BCM	81
Description	58	BCM : Diagnosis Procedure	81
DTC Logic	58	IPDM E/R (INTELLIGENT POWER DISTRIBU-	
Diagnosis Procedure	58	TION MODULE ENGINE ROOM)	81
U1010 CONTROL UNIT (CAN)	59	IPDM E/R (INTELLIGENT POWER DISTRIBU-	
DTC Logic	59	TION MODULE ENGINE ROOM) : Diagnosis Pro-	
Diagnosis Procedure	59	cedure	81
B260A IGNITION RELAY	60	SYMPTOM DIAGNOSIS	83
DTC Logic	60	PUSH-BUTTON IGNITION SWITCH DOES	
Diagnosis Procedure	60	NOT OPERATE	83
B2614 ACC RELAY CIRCUIT	62	Description	83
DTC Logic	62	Diagnosis Procedure	83
Diagnosis Procedure	62	REMOVAL AND INSTALLATION	84
Component Inspection (Relay)	63	BCM (BODY CONTROL MODULE)	84
B2615 BLOWER RELAY CIRCUIT	64	Removal and Installation	84
DTC Logic	64	PUSH BUTTON IGNITION SWITCH	85
Diagnosis Procedure	64	Exploded View	85
Component Inspection (Relay)	65	Removal and Installation	85
B2616 IGNITION RELAY CIRCUIT	66		
DTC Logic	66		
Diagnosis Procedure	66		
Component Inspection (Relay)	67		
B2618 BCM	68		
DTC Logic	68		
Diagnosis Procedure	68		
B261A PUSH-BUTTON IGNITION SWITCH	70		
DTC Logic	70		
Diagnosis Procedure	70		
B26F1 IGNITION RELAY	72		
DTC Logic	72		
Diagnosis Procedure	72		
B26F2 IGNITION RELAY	74		
DTC Logic	74		
Diagnosis Procedure	74		
B26F6 BCM	76		
DTC Logic	76		
Diagnosis Procedure	76		
PUSH-BUTTON IGNITION SWITCH	78		
Component Function Check	78		
Diagnosis Procedure	78		
Component Inspection	79		
POWER SUPPLY AND GROUND CIRCUIT	81		
BCM	81		
BCM : Diagnosis Procedure	81		
IPDM E/R (INTELLIGENT POWER DISTRIBU-			
TION MODULE ENGINE ROOM)	81		
IPDM E/R (INTELLIGENT POWER DISTRIBU-			
TION MODULE ENGINE ROOM) : Diagnosis Pro-			
cedure	81		
SYMPTOM DIAGNOSIS	83		
PUSH-BUTTON IGNITION SWITCH DOES			
NOT OPERATE	83		
Description	83		
Diagnosis Procedure	83		
REMOVAL AND INSTALLATION	84		
BCM (BODY CONTROL MODULE)	84		
Removal and Installation	84		
PUSH BUTTON IGNITION SWITCH	85		
Exploded View	85		
Removal and Installation	85		

PRECAUTION

PRECAUTIONS

Precaution for Supplemental Restraint System (SRS) "AIR BAG" and "SEAT BELT PRE-TENSIONER"

INFOID:000000009130980

The Supplemental Restraint System such as "AIR BAG" and "SEAT BELT PRE-TENSIONER", used along with a front seat belt, helps to reduce the risk or severity of injury to the driver and front passenger for certain types of collision. This system includes dual stage front air bag modules. The SRS system may only deploy one front air bag, depending on the severity of a collision and whether the front passenger seat is occupied. Information necessary to service the system safely is included in the SR and SB section of this Service Manual.

WARNING:

- To avoid rendering the SRS inoperative, which could increase the risk of personal injury or death in the event of a collision which would result in air bag inflation, all maintenance must be performed by an authorized NISSAN/INFINITI dealer.
- Improper maintenance, including incorrect removal and installation of the SRS, can lead to personal injury caused by unintentional activation of the system. For removal of Spiral Cable and Air Bag Module, see the SR section.
- Do not use electrical test equipment on any circuit related to the SRS unless instructed to in this Service Manual. SRS wiring harnesses can be identified by yellow and/or orange harnesses or harness connectors.

PRECAUTIONS WHEN USING POWER TOOLS (AIR OR ELECTRIC) AND HAMMERS

WARNING:

- When working near the Airbag Diagnosis Sensor Unit or other Airbag System sensors with the Ignition ON or engine running, DO NOT use air or electric power tools or strike near the sensor(s) with a hammer. Heavy vibration could activate the sensor(s) and deploy the air bag(s), possibly causing serious injury.
- When using air or electric power tools or hammers, always switch the Ignition OFF, disconnect the battery and wait at least three minutes before performing any service.

A
B
C
D
E
F
G
H
I
J
K
L

PCS

N
O
P

COMPONENT PARTS

< SYSTEM DESCRIPTION >

[IPDM E/R]

SYSTEM DESCRIPTION

COMPONENT PARTS

Component Parts Location

INFOID:000000009130981

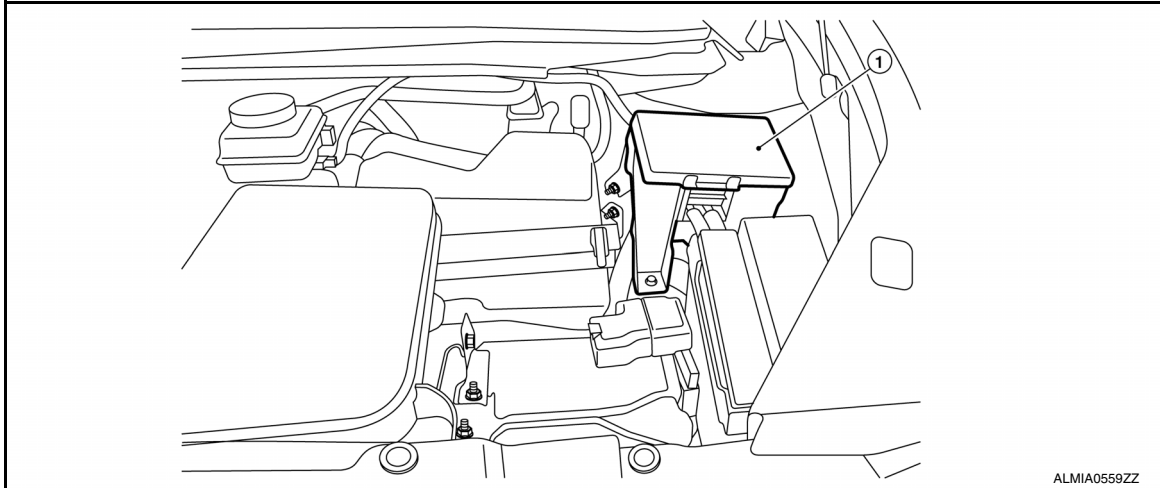

ALMIA0559ZZ

1. IPDM E/R

SYSTEM

< SYSTEM DESCRIPTION >

[IPDM E/R]

SYSTEM

RELAY CONTROL SYSTEM

RELAY CONTROL SYSTEM : System Diagram

INFOID:000000009130982

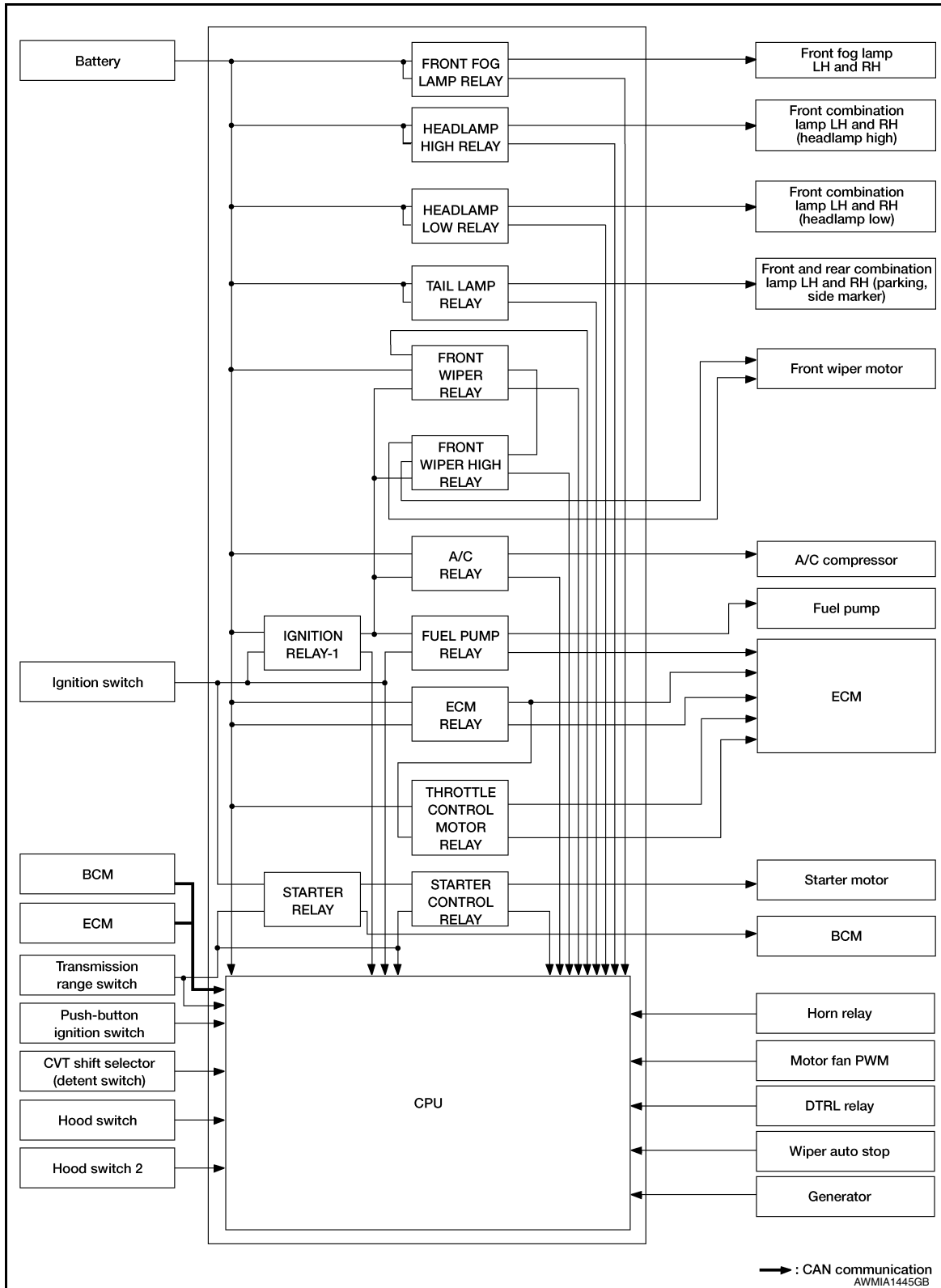

A
B
C
D
E
F
G
H
I
J
K
L
PCS
N
O
P

SYSTEM

< SYSTEM DESCRIPTION >

[IPDM E/R]

RELAY CONTROL SYSTEM : System Description

INFOID:000000009130983

IPDM E/R activates the internal control circuit to perform the relay ON-OFF control according to the input signals from various sensors and the request signals received from control units via CAN communication.

CAUTION:

IPDM E/R integrated relays cannot be removed.

Control relay	Input/output	Transmit unit	Control part	Reference page
Front fog lamp relay	Front fog lamp request signal	BCM (CAN)	Front fog lamp	EXL-134
<ul style="list-style-type: none"> • Headlamp low relay • Headlamp high relay 	<ul style="list-style-type: none"> • Low beam request signal • High beam request signal 	BCM (CAN)	<ul style="list-style-type: none"> • Headlamp low • Headlamp High 	EXL-126 EXL-124
Tail lamp relay	Position light request signal	BCM (CAN)	<ul style="list-style-type: none"> • Parking lamp • Side marker lamp • License plate lamp • Tail lamp 	EXL-136
<ul style="list-style-type: none"> • Front wiper relay • Front wiper high relay 	Front wiper request signal	BCM (CAN)	Front wiper	WW-60
	Front wiper auto stop signal	Front wiper motor		
Ignition relay-1	Ignition switch ON signal	BCM (CAN)	Ignition relay-1	PCS-60
	Vehicle speed signal	Combination meter (CAN)		
	Push-button ignition switch	Push-button ignition switch		
Fuel pump relay	Fuel pump request signal	ECM	Fuel pump	EC-447
ECM relay	ECM relay control signal	ECM	ECM relay	EC-179
Throttle control motor relay	Throttle control motor relay signal	ECM	Throttle control motor relay	EC-414
A/C relay	A/C compressor request signal	ECM (CAN)	A/C compressor	HAC-139

POWER CONSUMPTION CONTROL SYSTEM

POWER CONSUMPTION CONTROL SYSTEM : System Diagram

INFOID:000000009130984

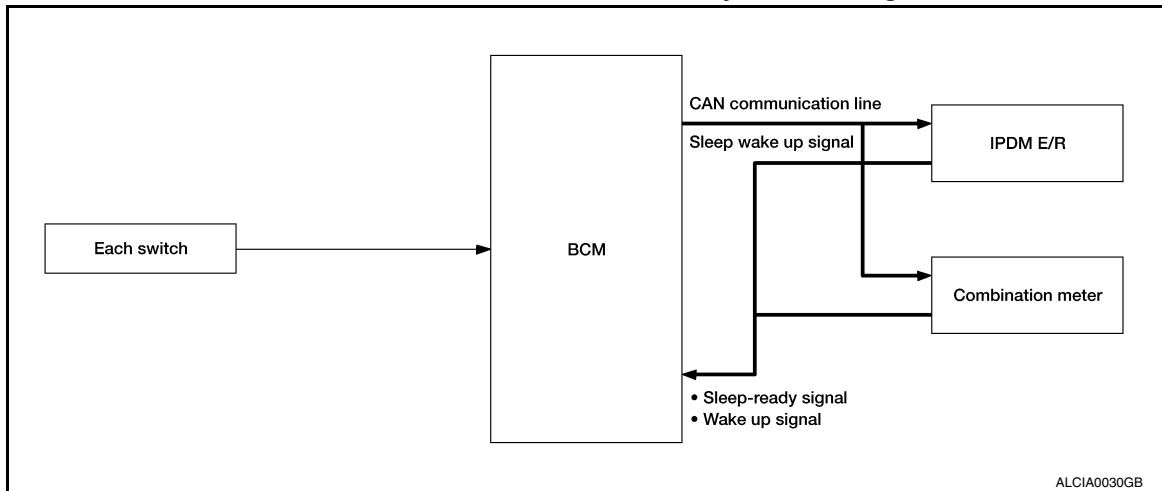

POWER CONSUMPTION CONTROL SYSTEM : System Description

INFOID:000000009130985

OUTLINE

- IPDM E/R incorporates a power consumption control function that reduces the power consumption according to the vehicle status.
- IPDM E/R changes its status (control mode) with the sleep wake up signal received from BCM via CAN communication.

Normal mode (wake-up)

- CAN communication is normally performed with other control units.

< SYSTEM DESCRIPTION >

- Individual unit control by IPDM E/R is normally performed.

Low power consumption mode (sleep)

- Low power consumption control is active.
- CAN transmission is stopped.

SLEEP MODE ACTIVATION

- IPDM E/R judges that the sleep-ready conditions are fulfilled when the ignition switch is OFF and none of the conditions below are present. Then it transmits a sleep-ready signal (ready) to BCM via CAN communication.
- Front wiper fail-safe operation
- Outputting signals to actuators
- Switches or relays operating
- Auto active test is starting
- Emergency OFF
- Output requests are being received from control units via CAN communication.
- IPDM E/R stops CAN communication and enters the low power consumption mode when it receives a sleep wake up signal (sleep) from BCM and the sleep-ready conditions are fulfilled.

WAKE-UP OPERATION

- IPDM E/R changes from the low power consumption mode to the normal mode when it receives a sleep wake-up signal (wake up) from BCM or any of the following conditions is fulfilled. In addition, it transmits a sleep-ready signal (not-ready) to BCM via CAN communication to report the CAN communication start.
- Ignition switch ON
- An output request is received from a control unit via CAN communication.

IGNITION BATTERY SAVER LOGIC

If the ignition is ON for 30 minutes with the engine OFF, the IPDM E/R and BCM turn OFF to save the battery.

A
B
C
D
E
F
G
H
I
J
K
L
N
O
P

PCS

DIAGNOSIS SYSTEM (IPDM E/R)

Diagnosis Description

INFOID:000000009130986

AUTO ACTIVE TEST

Description

In auto active test mode, the IPDM E/R sends a drive signal to the following systems to check their operation.

- Front wiper (LO, HI)
- Front fog lamps
- Parking lamps
- Side marker lamps
- Tail lamps
- License plate lamps
- Daytime running lamps
- Headlamps (LO, HI)
- A/C compressor
- Cooling fans (LO, HI)

Operation Procedure

CAUTION:

Do not start the engine.

NOTE:

When auto active test is performed with hood opened, sprinkle water on windshield before hand.

NOTE:

- If auto active test mode cannot be actuated, check door switch system. Refer to [DLK-170, "Component Function Check"](#).
 - When auto active test mode has to be cancelled halfway through test, turn ignition switch OFF.
1. Close the hood and lift the wiper arms from the windshield. (Prevent windshield damage due to wiper operation)
 2. Turn ignition switch OFF.
 3. Turn the ignition switch ON, and within 20 seconds, press the front door switch LH 10 times. Then turn the ignition switch OFF.
 4. Turn the ignition switch ON within 10 seconds. After that the horn sounds once, and the auto active test starts.
 5. After a series of the following operations is repeated 3 times, auto active test is completed.

Inspection in Auto Active Test Mode

When auto active test mode is actuated, the following operation sequence is repeated 3 times.

Operation sequence	Inspection Location	Operation
1	Front wiper	LO for 3 seconds → HI for 3 seconds
2	<ul style="list-style-type: none"> • Front fog lamps • Parking lamps • Side marker lamps • Tail lamps • License plate lamps 	10 seconds
3	Daytime running lamps	10 seconds
4	Headlamps	LO ⇔ HI 5 times
5	A/C compressor	ON ⇔ OFF 5 times
6*	Cooling fans	LO for 5 seconds → HI for 5 seconds

*: Outputs duty ratio of 50% for 5 seconds → duty ratio of 100% for 5 seconds on the cooling fan control module.

DIAGNOSIS SYSTEM (IPDM E/R)

[IPDM E/R]

< SYSTEM DESCRIPTION >

Concept of auto active test

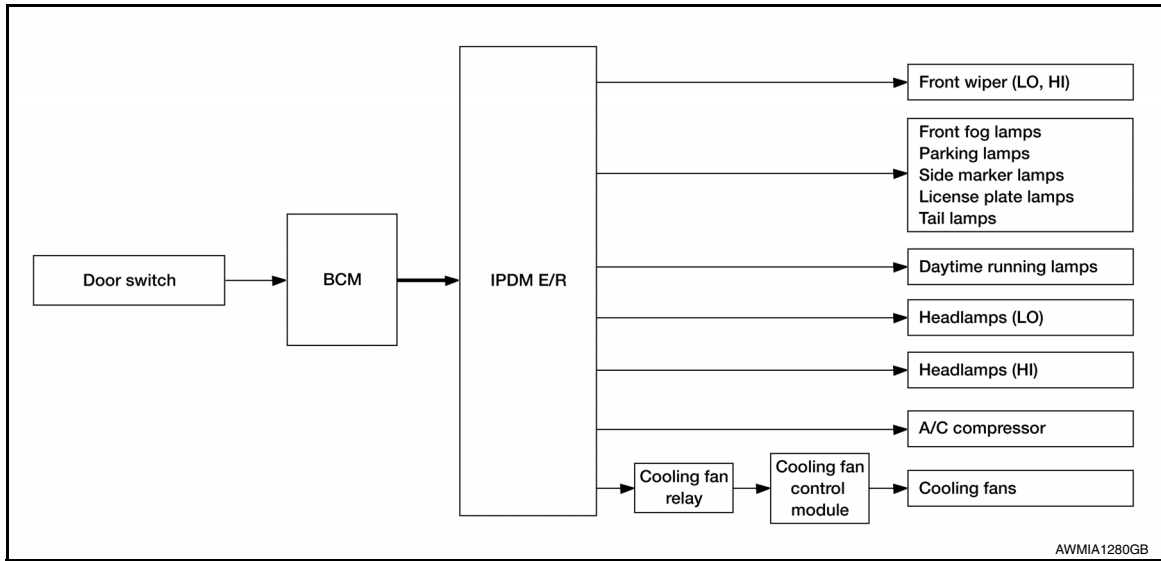

- IPDM E/R starts the auto active test with the door switch signals transmitted by BCM via CAN communication. Therefore, the CAN communication line between IPDM E/R and BCM is considered normal if the auto active test starts successfully.
- The auto active test facilitates troubleshooting if any systems controlled by IPDM E/R cannot be operated.

Diagnosis chart in auto active test mode

Symptom	Inspection contents	Possible cause
Any of the following components do not operate <ul style="list-style-type: none"> • Front fog lamps • Parking lamps • Side marker lamps • License plate lamps • Tail lamps • Daytime running lamps • Headlamp (HI, LO) • Front wiper 	Perform auto active test. Does the applicable system operate?	YES BCM signal input circuit
		NO <ul style="list-style-type: none"> • Lamp or motor • Lamp or motor ground circuit • Harness or connector between IPDM E/R and applicable system • IPDM E/R
Cooling fans do not operate	Perform auto active test. Do the cooling fans operate?	YES <ul style="list-style-type: none"> • ECM signal input circuit • CAN communication signal between ECM and IPDM E/R
		NO <ul style="list-style-type: none"> • Cooling fans • Harness or connectors between cooling fans and cooling fan control module • Cooling fan control module • Harness or connectors between cooling fan relay and cooling fan control module • Cooling fan relay • Harness or connectors between IPDM E/R and cooling fan relay • IPDM E/R

CONSULT Function (IPDM E/R)

INFOID:000000009130987

CAUTION:

After disconnecting the CONSULT vehicle interface (VI) from the data link connector, the ignition must be cycled OFF → ON (for at least 5 seconds) → OFF. If this step is not performed, the BCM may not go to "sleep mode", potentially causing a discharged battery and a no-start condition.

DIAGNOSIS SYSTEM (IPDM E/R)

[IPDM E/R]

< SYSTEM DESCRIPTION >

APPLICATION ITEM

CONSULT performs the following functions via CAN communication with IPDM E/R.

Direct Diagnostic Mode	Description
Ecu Identification	The IPDM E/R part number is displayed.
Self Diagnostic Result	The IPDM E/R self diagnostic results are displayed.
Data Monitor	The IPDM E/R input/output data is displayed in real time.
Active Test	The IPDM E/R activates outputs to test components.
CAN Diag Support Mntr	The result of transmit/receive diagnosis of CAN communication is displayed.

ECU IDENTIFICATION

The IPDM E/R part number is displayed.

SELF DIAGNOSTIC RESULT

Refer to [PCS-20, "DTC Index"](#).

DATA MONITOR

Monitor Item [Unit]	Main Signals	Description
RAD FAN REQ [%]	×	Indicates cooling fan speed signal received from ECM on CAN communication line
AC COMP REQ [On/Off]	×	Indicates A/C compressor request signal received from ECM on CAN communication line
TAIL&CLR REQ [On/Off]	×	Indicates position light request signal received from BCM on CAN communication line
HL LO REQ [On/Off]	×	Indicates low beam request signal received from BCM on CAN communication line
HL HI REQ [On/Off]	×	Indicates high beam request signal received from BCM on CAN communication line
FR FOG REQ [On/Off]	×	Indicates front fog light request signal received from BCM on CAN communication line
FR WIP REQ [Stop/1LOW/Low/Hi]	×	Indicates front wiper request signal received from BCM on CAN communication line
WIP AUTO STOP [STOP P/ACT P]	×	Indicates condition of front wiper auto stop signal
WIP PROT [Off/BLOCK]	×	Indicates condition of front wiper fail-safe operation
IGN RLY1 -REQ [On/Off]		Indicates ignition switch ON signal received from BCM on CAN communication line
IGN RLY [On/Off]	×	Indicates condition of ignition relay
PUSH SW [On/Off]		Indicates condition of push-button ignition switch
INTER/NP SW [On/Off]		Indicates condition of CVT shift position
ST RLY CONT [On/Off]		Indicates starter relay status signal received from BCM on CAN communication line
IHBT RLY -REQ [On/Off]		Indicates starter control relay signal received from BCM on CAN communication line
ST/INHI RLY [Off/ ST /INHI]		Indicates condition of starter relay and starter control relay
DETENT SW [On/Off]		Indicates condition of CVT shift selector (park position switch)
DTRL REQ [Off]		Indicates daytime light request signal received from BCM on CAN communication line
HOOD SW [On/Off]		Indicates condition of hood switch
THFT HRN REQ [On/Off]		Indicates theft warning horn request signal received from BCM on CAN communication line

DIAGNOSIS SYSTEM (IPDM E/R)

< SYSTEM DESCRIPTION >

[IPDM E/R]

Monitor Item [Unit]	Main Signals	Description
HORN CHIRP [On/Off]		Indicates horn reminder signal received from BCM on CAN communication line
HOOD SW 2 [On/Off]		Indicates condition of hood switch 2

ACTIVE TEST

Test item	Description
HORN	This test is able to check horn operation [On].
FRONT WIPER	This test is able to check wiper motor operation [Hi/Lo/Off].
MOTOR FAN	This test is able to check cooling fan operation [4/3/2/1].
EXTERNAL LAMPS	This test is able to check external lamp operation [Fog/Hi/Lo/Tail/Off].

CAN DIAG SUPPORT MNTR

Refer to [LAN-23. "CAN Diagnostic Support Monitor"](#).

A
B
C
D
E
F
G
H
I
J
K
L

PCS

N
O
P

IPDM E/R (INTELLIGENT POWER DISTRIBUTION MODULE ENGINE ROOM)

< ECU DIAGNOSIS INFORMATION >

[IPDM E/R]

ECU DIAGNOSIS INFORMATION

IPDM E/R (INTELLIGENT POWER DISTRIBUTION MODULE ENGINE ROOM)

Reference Value

INFOID:000000009130988

VALUES ON THE DIAGNOSIS TOOL

Monitor Item	Condition		Value/Status
RAD FAN REQ	Engine idle speed	Changes depending on engine coolant temperature, air conditioner operation status, vehicle speed, etc.	0 - 100 %
AC COMP REQ	Engine running	A/C switch OFF	Off
		A/C switch ON (Compressor is operating)	On
TAIL&CLR REQ	Lighting switch OFF		Off
	Lighting switch 1ST, 2ND, HI or AUTO (Light is illuminated)		On
HL LO REQ	Lighting switch OFF		Off
	Lighting switch 2ND HI or AUTO (Light is illuminated)		On
HL HI REQ	Lighting switch OFF		Off
	Lighting switch HI		On
FR FOG REQ	Lighting switch 2ND or AUTO (Light is illuminated)	Front fog lamp switch OFF	Off
		<ul style="list-style-type: none"> • Front fog lamp switch ON • Daytime running light activated (Only for Canada models) 	On
FR WIP REQ	Ignition switch ON	Front wiper switch OFF	STOP
		Front wiper switch INT	1LOW
		Front wiper switch LO	Low
		Front wiper switch HI	Hi
WIP AUTO STOP	Ignition switch ON	Front wiper stop position	STOP P
		Any position other than front wiper stop position	ACT P
WIP PROT	Ignition switch ON	Front wiper operates normally	Off
		Front wiper stops at fail-safe operation	BLOCK
IGN RLY1 -REQ	Ignition switch OFF or ACC		Off
	Ignition switch ON		On
IGN RLY	Ignition switch OFF or ACC		Off
	Ignition switch ON		On
PUSH SW	Release the push-button ignition switch		Off
	Press the push-button ignition switch		On
INTER/NP SW	Ignition switch ON	CVT selector lever in any position other than P or N	Off
		CVT selector lever in P or N position	On
ST RLY CONT	Ignition switch ON		Off
	At engine cranking		On
IHBT RLY -REQ	Ignition switch ON		Off
	At engine cranking		On

IPDM E/R (INTELLIGENT POWER DISTRIBUTION MODULE ENGINE ROOM)

< ECU DIAGNOSIS INFORMATION >

[IPDM E/R]

Monitor Item	Condition	Value/Status
ST/INHI RLY	Ignition switch ON	Off
	At engine cranking	ST →INHI
	The status of starter relay or starter control relay cannot be recognized by the battery voltage malfunction, etc. when the starter relay is ON and the starter control relay is OFF	UNKWN
DETENT SW	Ignition switch ON <ul style="list-style-type: none"> • Press the selector button with CVT selector lever in P position • CVT selector lever in any position other than P 	Off
	Release the CVT selector button with CVT selector lever in P position	On
DTRL REQ	DTRL OFF	Off
	DTRL ON	On
HOOD SW	Hood closed	Off
	Hood open	On
THFT HRN REQ	Not operated	Off
	<ul style="list-style-type: none"> • Panic alarm is activated • Horn is activated with VEHICLE SECURITY (THEFT WARNING) SYSTEM 	On
HORN CHIRP	Not operated	Off
	Door locking with Intelligent Key (horn chirp mode)	On
HOOD SW 2	Hood closed	Off
	Hood open	On

A
B
C
D
E
F
G
H
I
J
K
L
N
O
P

PCS

IPDM E/R (INTELLIGENT POWER DISTRIBUTION MODULE ENGINE ROOM)

< ECU DIAGNOSIS INFORMATION >

[IPDM E/R]

TERMINAL LAYOUT

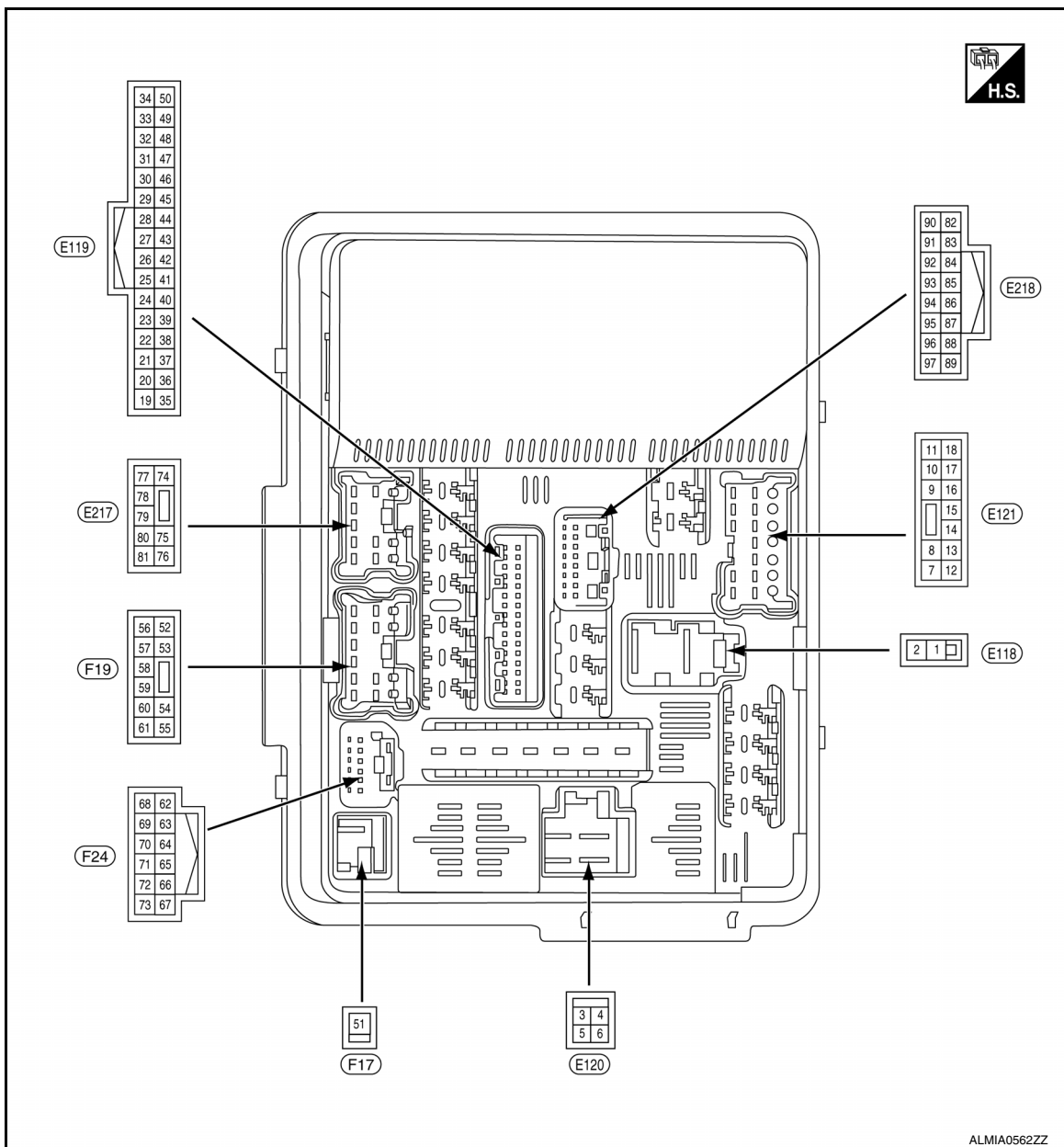

PHYSICAL VALUES

Terminal No. (Wire color)		Description		Condition		Value (Approx.)
+	-	Signal name	Input/ Output			
1 (R)	Ground	Fusible link main	Input	Ignition switch OFF		Battery voltage
2 (L)	Ground	Fusible link IPDM E/R	Input	Ignition switch OFF		Battery voltage
3 (G)	Ground	Fusible link ignition switch	Input	Ignition switch ON		Battery voltage
7 (B)	Ground	Ground (Power)	—	Ignition switch ON		0V
9 (G)	Ground	Tail RH	Output	Ignition switch ON	Lighting switch OFF	0V
					Lighting switch 1ST	Battery voltage

IPDM E/R (INTELLIGENT POWER DISTRIBUTION MODULE ENGINE ROOM)

< ECU DIAGNOSIS INFORMATION >

[IPDM E/R]

Terminal No. (Wire color)		Description		Condition		Value (Approx.)
10 (L)	Ground	Tail LH	Output	Ignition switch OFF	Lighting switch OFF	0V
				Ignition switch ON	Lighting switch 1ST	Battery voltage
11 (Y)	Ground	Front wiper LO	Output	Ignition switch OFF	Front wiper switch OFF	0V
				Ignition switch ON	Front wiper switch LO	Battery voltage
13 (LG)	Ground	ECM battery	Output	Ignition switch OFF		0V
				Ignition switch ON		Battery voltage
14 (V)	Ground	Daytime running lamps	Output	Ignition switch OFF		Battery voltage
15 (R)	Ground	Fuel pump	Output	Approximately 1 second or more after turning the ignition switch ON		0V
				<ul style="list-style-type: none"> • Approximately 1 second after turning the ignition switch ON • Engine running 		Battery voltage
18 (L)	Ground	Front wiper HI	Output	Ignition switch OFF	Front wiper switch OFF	0V
				Ignition switch ON	Front wiper switch HI	Battery voltage
19 (SB)	Ground	AWD control unit	Output	Ignition switch OFF		0V
				Ignition switch ON		Battery voltage
22 (W)	Ground	Horn relay	Input	The horn is deactivated		Battery voltage
				The horn is activated		0V
23 (LG)	Ground	Horn switch	Input	The horn is deactivated		Battery voltage
				The horn is activated		0V
27 (B)	Ground	Fan motor relay mid	Input	Ignition switch OFF or ACC		0V
				Ignition switch ON		0.7V
28 (P)	—	CAN-L	Input/Output	—		—
29 (L)	—	CAN-H	Input/Output	—		—
31 (BG)	Ground	Detent switch	Input	Ignition switch ON	Press the CVT selector button (CVT selector lever P)	Battery voltage
					<ul style="list-style-type: none"> • CVT selector lever in any position other than P • Release the CVT selector button (CVT selector lever P) 	
33 (R)	Ground	Starter control	Input	Ignition switch ON	CVT selector lever in any position other than P or N	0V
					CVT selector lever P or N	Battery voltage
34 (GR)	Ground	Wiper autostop	Input	Ignition switch ON	Front wiper stop position	0V
					Any position other than front wiper stop position	Battery voltage
35 (BR)	Ground	ABS actuator and electric unit (control unit)	Output	Ignition switch OFF		0V
				Ignition switch ON		Battery voltage
36 (W)	Ground	Cooling fan relay	Output	Ignition switch OFF		0V
				Ignition switch ON		Battery voltage

A
B
C
D
E
F
G
H
I
J
K
L

PCS

N
O
P

IPDM E/R (INTELLIGENT POWER DISTRIBUTION MODULE ENGINE ROOM)

< ECU DIAGNOSIS INFORMATION >

[IPDM E/R]

Terminal No. (Wire color)		Description		Condition		Value (Approx.)
+	-	Signal name	Input/ Output			
37 (W)	Ground	BCM	Input	Ignition switch ON	CVT selector lever in any position other than P or N position	0V
					CVT selector lever P or N position	Battery voltage
38 (P)	Ground	Push start switch	Input	Press the push-button ignition switch		0V
				Release the push-button ignition switch		Battery voltage
41 (B)	Ground	Ground (signal)	—	Ignition switch ON		0V
43 (L)	Ground	Ignition signal*	Input	Ignition switch OFF or ACC		Battery voltage
				Ignition switch ON		0V
45 (LG)	Ground	Power distribution sensor signal-E/R	—	<ul style="list-style-type: none"> • Ignition switch ON (READY) • Both A/C switch and blower motor switch ON (A/C compressor oper- ates) 		1.0 - 4.0V
47 (Y)	Ground	Power distribution sensor power-E/R	—	Ignition switch ON		5V
48 (V)	Ground	Power distribution sensor ground-E/R	—	Ignition switch ON		0V
51 (W)	Ground	Starter motor	Output	At engine cranking		Battery voltage
52 (W)	Ground	O2 sensor #2	Output	Ignition switch OFF		0V
				Ignition switch ON		Battery voltage
53 (W)	Ground	O2 sensor #1	Output	Ignition switch OFF		0V
				Ignition switch ON		Battery voltage
54 (L)	Ground	Injector #1	Output	Ignition switch OFF		0V
				Ignition switch ON		Battery voltage
55 (W)	Ground	Ignition coil	Output	Ignition switch OFF (For a few seconds after turning ignition switch OFF)		0V
				<ul style="list-style-type: none"> • Ignition switch ON • Ignition switch OFF (More than a few seconds after turn- ing ignition switch OFF) 		Battery voltage
56 (SB)	Ground	A/C compressor	Output	Engine running	A/C compressor OFF	0V
					A/C compressor ON (A/C compressor is oper- ating)	Battery voltage
57 (R)	Ground	Electronic throttle control	Output	Ignition switch OFF (For a few seconds after turning ignition switch OFF)		0V
				<ul style="list-style-type: none"> • Ignition switch ON • Ignition switch OFF (More than a few seconds after turn- ing ignition switch OFF) 		Battery voltage
58 (GR)	Ground	ECM battery	Output	Ignition switch OFF		Battery voltage

IPDM E/R (INTELLIGENT POWER DISTRIBUTION MODULE ENGINE ROOM)

< ECU DIAGNOSIS INFORMATION >

[IPDM E/R]

Terminal No. (Wire color)		Description		Condition	Value (Approx.)
+	-	Signal name	Input/ Output		
59 (L)	Ground	Engine solenoid	Output	Ignition switch OFF (For a few seconds after turning ignition switch OFF)	0V
				<ul style="list-style-type: none"> • Ignition switch ON • Ignition switch OFF (More than a few seconds after turning ignition switch OFF) 	Battery voltage
60 (LG)	Ground	Injector #2	Output	Ignition switch OFF	0V
				Ignition switch ON	Battery voltage
61 (Y)	Ground	Transmission control module	Output	Ignition switch OFF	0V
				Ignition switch ON	Battery voltage
63 (L)	Ground	Inhibit switch	Output	Ignition switch OFF	0V
				Ignition switch ON	Battery voltage
64 (LG)	Ground	Ignition relay power supply	Output	Ignition switch OFF	0V
				Ignition switch ON	Battery voltage
65 (G)	Ground	Throttle control motor relay	Output	Ignition switch ON → OFF	0 - 1.0V ↓ Battery voltage ↓ 0V
				Ignition switch ON	0 - 1.0V
66 (G)	Ground	N/P switch	Input	Ignition switch ON	CVT selector lever in P or N position Battery voltage
				CVT selector lever in any position other than P or N position	0V
69 (W)	Ground	Fuel pump relay	Output	<ul style="list-style-type: none"> • Approximately 1 second after turning the ignition switch ON • Engine running 	0 - 1.0V
				Approximately 1 second or more after turning the ignition switch ON	Battery voltage

A
B
C
D
E
F
G
H
I
J
K
L
N
O
P

PCS

IPDM E/R (INTELLIGENT POWER DISTRIBUTION MODULE ENGINE ROOM)

< ECU DIAGNOSIS INFORMATION >

[IPDM E/R]

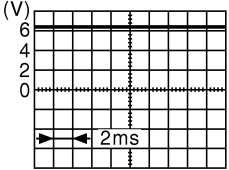
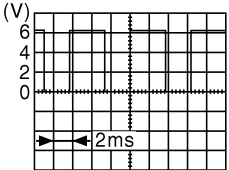
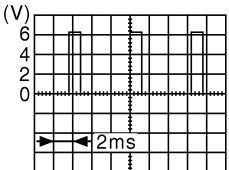
Terminal No. (Wire color)		Description		Condition	Value (Approx.)	
+	-	Signal name	Input/ Output			
71 (LG)	Ground	Alternator C	Output	Ignition switch ON	 <small>JPMIA0001GB</small> 6.3V	
				40% is set on "Active test", "ALTERNATOR DUTY" of "ENGINE"	 <small>JPMIA0002GB</small> 3.8V	
				80% is set on "Active test", "ALTERNATOR DUTY" of "ENGINE"	 <small>JPMIA0003GB</small> 1.4V	
72 (V)	Ground	ECM relay (Self shut-off)	Output	Ignition switch OFF (For a few seconds after turning ignition switch OFF)	Battery voltage	
				<ul style="list-style-type: none"> • Ignition switch ON • Ignition switch OFF (More than a few seconds after turning ignition switch OFF) 	0 - 1.5V	
74 (R)	Ground	Washer motor	Output	Ignition switch ON	Battery voltage	
75 (R)	Ground	Headlamp LO RH	Output	Ignition switch OFF	Lighting switch OFF	0V
				Ignition switch ON	Lighting switch 2ND	Battery voltage
76 (L)	Ground	Headlamp LO LH	Output	Ignition switch OFF	Lighting switch OFF	0V
				Ignition switch ON	Lighting switch 2ND	Battery voltage
78 (W)	Ground	Front fog lamp RH	Output	Ignition switch OFF	Fog lamp switch OFF	0V
				Ignition switch ON	Fog lamp switch ON	Battery voltage
79 (L)	Ground	Front fog lamp LH	Output	Ignition switch OFF	Fog lamp switch OFF	0V
				Ignition switch ON	Fog lamp switch ON	Battery voltage
80 (W)	Ground	Headlamp HI RH	Output	Ignition switch OFF	<ul style="list-style-type: none"> • Lighting switch HI • Lighting switch PASS 	Battery voltage
				Ignition switch ON	Lighting switch OFF	0V
81 (G)	Ground	Headlamp HI LH	Output	Ignition switch OFF	<ul style="list-style-type: none"> • Lighting switch HI • Lighting switch PASS 	Battery voltage
				Ignition switch ON	Lighting switch OFF	0V

IPDM E/R (INTELLIGENT POWER DISTRIBUTION MODULE ENGINE ROOM)

< ECU DIAGNOSIS INFORMATION >

[IPDM E/R]

Terminal No. (Wire color)		Description		Condition		Value (Approx.)
+	-	Signal name	Input/ Output			
82 (P)	Ground	Power distribution sensor signal-fem	—	<ul style="list-style-type: none"> Ignition switch ON (READY) Both A/C switch and blower motor switch ON (electric compressor operates) 		1.0 - 4.0V
83 (G)	Ground	Power distribution sensor power-fem	—	Ignition switch ON		5V
84 (SB)	Ground	Headlamp levelizer RH	Output	Ignition switch ON	Lighting switch 1ST	Battery voltage
					Lighting switch OFF	0V
85 (P)	Ground	Daytime running lamps relay	Output	Ignition switch ON	Daytime light system active	Battery voltage
				Ignition switch ON	Daytime light system inactive	0V
86 (L)	Ground	Power distribution sensor ground-fem	—	Ignition switch ON		0V
90 (LG)	Ground	Clearance lamps	Output	Ignition switch ON	Lighting switch 1ST	Battery voltage
					Lighting switch OFF	0V
92 (L)	Ground	Headlamp levelizer LH	Output	Ignition switch ON	Lighting switch 1ST	Battery voltage
					Lighting switch OFF	0V
93 (V)	Ground	Fan motor PWM	Output	Engine idling		0-5V
94 (LG)	Ground	Hood switch 2	Input	Ignition switch ON	Hood closed	0V
					Hood open	Battery voltage
96 (R)	Ground	Hood switch	Input	Ignition switch ON	Hood closed	0V
					Hood open	Battery voltage

*: Ignition battery saver logic turns OFF the IPDM E/R and BCM if the ignition is ON for 30 minutes with the engine OFF.

Fail Safe

INFOID:000000009130989

CAN COMMUNICATION CONTROL

When CAN communication with ECM and BCM is impossible, IPDM E/R performs fail-safe control. After CAN communication recovers normally, it also returns to normal control.

If No CAN Communication Is Available With BCM

Control part	Fail-safe in operation
Headlamp	<ul style="list-style-type: none"> Turns ON the headlamp low relay when the ignition switch is turned ON Turns OFF the headlamp low relay when the ignition switch is turned OFF Headlamp high relay OFF
<ul style="list-style-type: none"> Parking lamps Side marker lamps License plate lamps Tail lamps 	<ul style="list-style-type: none"> Turns ON the tail lamp relay when the ignition switch is turned ON Turns OFF the tail lamp relay when the ignition switch is turned OFF
Front wiper	<ul style="list-style-type: none"> The status just before activation of fail-safe control is maintained until the ignition switch is turned OFF while the front wiper is operating at LO or HI speed. The wiper is operated at LO speed until the ignition switch is turned OFF if the fail-safe control is activated while the front wiper is set in the INT mode and the front wiper motor is operating.
Horn	Horn OFF
Ignition relay	The status just before activation of fail-safe is maintained.

IGNITION RELAY MALFUNCTION DETECTION FUNCTION

• IPDM E/R monitors the voltage at the contact circuit and excitation coil circuit of the ignition relay inside it.

IPDM E/R (INTELLIGENT POWER DISTRIBUTION MODULE ENGINE ROOM)

< ECU DIAGNOSIS INFORMATION >

[IPDM E/R]

- IPDM E/R judges the ignition relay error if the voltage differs between the contact circuit and the excitation coil circuit.
- If the ignition relay cannot turn OFF due to contact seizure, it activates the tail lamp relay for 10 minutes to alert the user to the ignition relay malfunction when the ignition switch is turned OFF.

DTC	Ignition switch	Ignition relay	Tail lamp relay
—	ON	ON	—
—	OFF	OFF	—
B2098: IGN RELAY ON	OFF	ON	ON (10 minutes)
B2099: IGN RELAY OFF	ON	OFF	—

NOTE:

The tail lamp turns OFF when the ignition switch is turned ON.

FRONT WIPER CONTROL

IPDM E/R detects front wiper stop position by a front wiper auto stop signal.

When a front wiper auto stop signal is in the conditions listed below, IPDM E/R stops power supply to wiper after repeating a front wiper 10 second activation and 20 second stop five times.

Ignition switch	Front wiper switch	Auto stop signal
ON	OFF	Front wiper stop position signal cannot be input 10 seconds.
	ON	The signal does not change for 10 seconds.

NOTE:

This operation status can be confirmed on the IPDM E/R “Data Monitor” that displays “BLOCK” for the item “WIP PROT” while the wiper is stopped.

STARTER MOTOR PROTECTION FUNCTION

IPDM E/R turns OFF the starter control relay to protect the starter motor when the starter control relay remains active for 90 seconds.

DTC Index

INFOID:000000009130990

CONSULT display	Fail-safe	TIME ^{NOTE}		Refer to
No DTC is detected. Further testing may be required.	—	—	—	—
U1000: CAN COMM CIRCUIT	×	CRNT	1 – 39	PCS-27
U1010: CONTROL UNIT (CAN)	×	CRNT	1 – 39	PCS-28
B2098: IGN RELAY ON	×	CRNT	1 – 39	PCS-29
B2099: IGN RELAY OFF	—	CRNT	1 – 39	PCS-30
B210B: INHIBIT relay ON stuck failure	—	CRNT	1 – 39	SEC-85
B210C: INHIBIT relay OFF stuck failure	—	CRNT	1 – 39	SEC-86
B210D: STARTER relay ON stuck failure	—	CRNT	1 – 39	SEC-87
B210E: STARTER relay OFF stuck failure	—	CRNT	1 – 39	SEC-88
B210F: Interlock/NP switch ON stuck failure	—	CRNT	1 – 39	SEC-90
B2110: Interlock/NP switch OFF stuck failure	—	CRNT	1 – 39	SEC-93

NOTE:

The details of TIME display are as follows.

- CRNT: The malfunctions that are detected now
- 1 - 39: The number is indicated when it is normal at present and a malfunction was detected in the past. It increases like 0 → 1 → 2 ··· 38 → 39 after returning to the normal condition whenever IGN OFF → ON. It is fixed to 39 until the self-diagnosis results are erased if it is over 39. It returns to 0 when a malfunction is detected again in the process.

IPDM E/R (INTELLIGENT POWER DISTRIBUTION MODULE ENGINE ROOM)

< WIRING DIAGRAM >

[IPDM E/R]

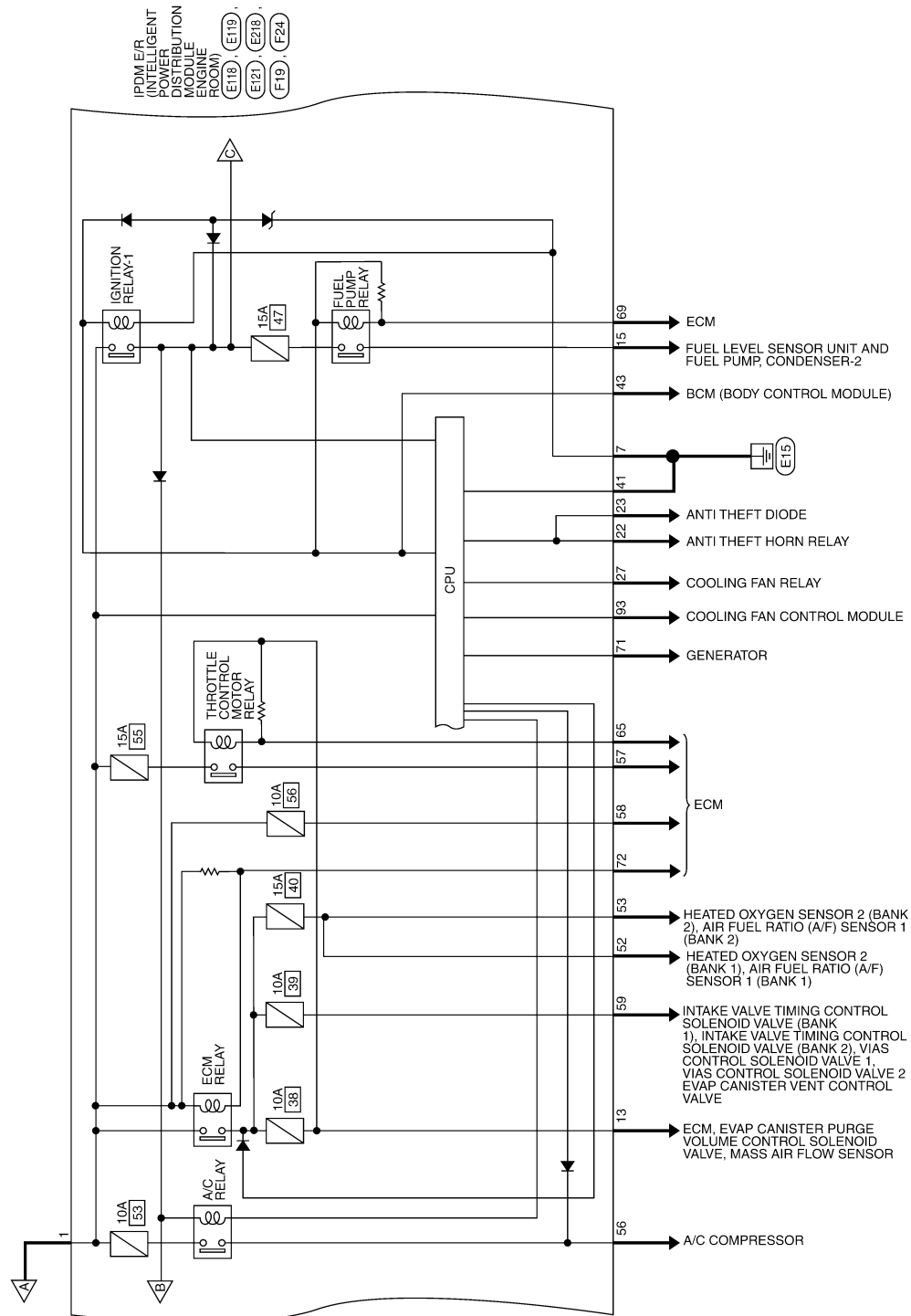

ABMWA2080GB

IPDM E/R (INTELLIGENT POWER DISTRIBUTION MODULE ENGINE ROOM)

< WIRING DIAGRAM >

[IPDM E/R]

W4 : WITH ALL WHEEL DRIVE

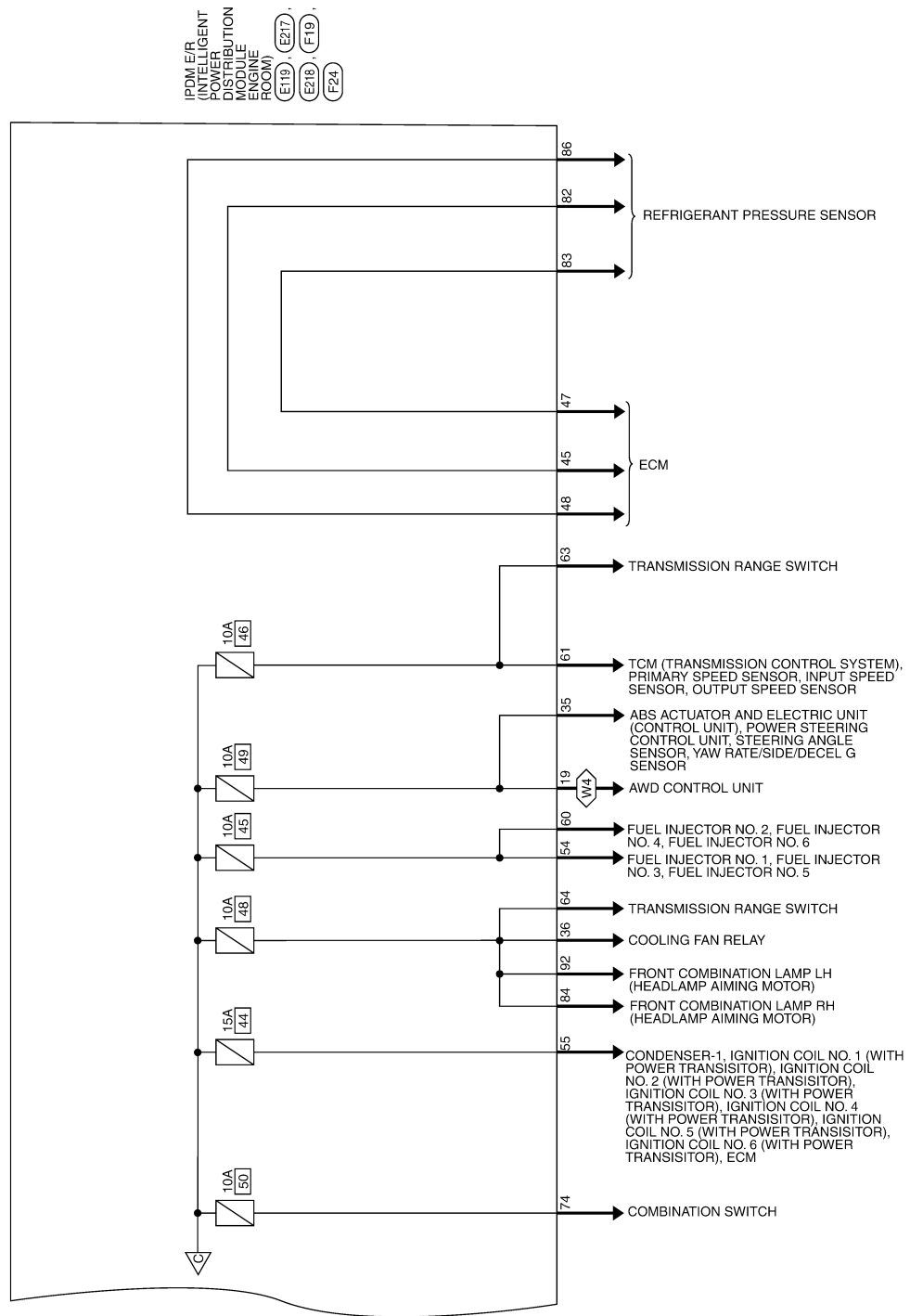

ABMWA2081GB

A
B
C
D
E
F
G
H
I
J
K
L
N
O
P

PCS

IPDM E/R (INTELLIGENT POWER DISTRIBUTION MODULE ENGINE ROOM) CONNECTORS

Connector No.	E7
Connector Name	FUSIBLE LINK BOX (BATTERY)
Connector Color	GRAY

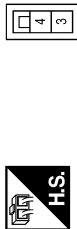

Terminal No.	Color of Wire	Signal Name
4	R	-

Connector No.	E27
Connector Name	FUSIBLE LINK BOX (BATTERY)
Connector Color	BROWN



Terminal No.	Color of Wire	Signal Name
1	W	-
2	L	-

Connector No.	E118
Connector Name	IPDM E/R (INTELLIGENT POWER DISTRIBUTION MODULE ENGINE ROOM)
Connector Color	BLACK



Terminal No.	Color of Wire	Signal Name
1	R	F/L MAIN
2	L	F/L USM

Connector No.	E119
Connector Name	IPDM E/R (INTELLIGENT POWER DISTRIBUTION MODULE ENGINE ROOM)
Connector Color	WHITE

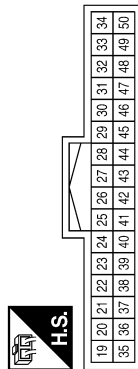

Terminal No.	Color of Wire	Signal Name
19	SB	SUB ECU
20	-	-
21	-	-
22	W	HORN RLY
23	LG	HORN SW
24	-	-
25	-	-
26	-	-
27	B	MOTOR FAN RLY MID
28	P	CAN-L
29	L	CAN-H

Terminal No.	Color of Wire	Signal Name
30	-	-
31	BG	DETENT SW
32	-	-
33	R	START CONT
34	GR	WIPER AUTOSTOP
35	BR	ABS ECU
36	W	START IG-E/R
37	W	CLUTCH I/L SW
38	P	PUSH START SW
39	-	-
40	-	-
41	B	GND (SIGNAL)
42	-	-
43	L	IGN SIGNAL
44	-	-
45	LG	PD SENS SIG-E/R
46	-	-
47	Y	PD SENS PWR-E/R
48	V	PD SENS GND-E/R
49	-	-
50	-	-

Connector No.	E120
Connector Name	IPDM E/R (INTELLIGENT POWER DISTRIBUTION MODULE ENGINE ROOM)
Connector Color	WHITE



Terminal No.	Color of Wire	Signal Name
3	G	F/L IGNSW
4	-	-
5	-	-
6	-	-

ABMIA4795GB

IPDM E/R (INTELLIGENT POWER DISTRIBUTION MODULE ENGINE ROOM)

< WIRING DIAGRAM >

[IPDM E/R]

Connector No.	E217
Connector Name	IPDM E/R (INTELLIGENT POWER DISTRIBUTION MODULE ENGINE ROOM)
Connector Color	WHITE

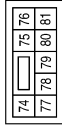

Terminal No.	Color of Wire	Signal Name
74	R	WASH MTR
75	R	HEADLAMP LO RH
76	L	HEADLAMP LO LH
77	-	-
78	W	FR FOG LAMP RH
79	L	FR FOG LAMP LH
80	W	HEADLAMP HI RH
81	G	HEADLAMP HI LH

Connector No.	E121
Connector Name	IPDM E/R (INTELLIGENT POWER DISTRIBUTION MODULE ENGINE ROOM)
Connector Color	WHITE

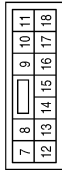

Terminal No.	Color of Wire	Signal Name
7	B	GND (POWER)
8	-	-
9	G	TAIL RH
10	L	TAIL LH
11	Y	FR WIPER LO
12	-	-
13	LG	ECM VB
14	V	DTRL
15	R	FUEL PUMP
16	-	-
17	-	-
18	L	FR WIPER HI

Connector No.	E218
Connector Name	IPDM E/R (INTELLIGENT POWER DISTRIBUTION MODULE ENGINE ROOM)
Connector Color	WHITE

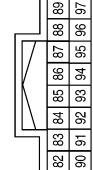

Terminal No.	Color of Wire	Signal Name
82	P	PD SENS SIG-FEM
83	G	PD SENS PWR-FEM

Terminal No.	Color of Wire	Signal Name
84	SB	H/L LEVELIZER RH
85	P	DTRL RLY
86	L	PD SENS GND-FEM
87	-	-
88	-	-
89	-	-
90	LG	CLEARANCE
91	-	-
92	L	H/L LEVELIZER LH
93	V	MOTOR FAN PWM

Terminal No.	Color of Wire	Signal Name
94	LG	HOODSW 2
95	-	-
96	R	HOODSW
97	-	-

ABMIA4806GB

A
B
C
D
E
F
G
H
I
J
K
L
M
N
O
P

PCS

IPDM E/R (INTELLIGENT POWER DISTRIBUTION MODULE ENGINE ROOM)

< WIRING DIAGRAM >

[IPDM E/R]

Connector No.	F24
Connector Name	IPDM E/R (INTELLIGENT POWER DISTRIBUTION MODULE ENGINE ROOM)
Connector Color	WHITE

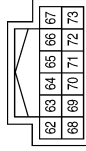

Terminal No.	Color of Wire	Signal Name
62	-	-
63	L	INHIBIT SW
64	LG	START IG EGI
65	G	MOTRLY
66	G	NP SW
67	-	-
68	-	-
69	W	FPR
70	-	-
71	LG	ALT C
72	V	SSOFF
73	-	-

Connector No.	F19
Connector Name	IPDM E/R (INTELLIGENT POWER DISTRIBUTION MODULE ENGINE ROOM)
Connector Color	WHITE

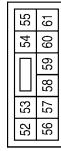

Terminal No.	Color of Wire	Signal Name
52	W	O2SENS #2
53	W	O2SENS #1
54	L	INJECTOR #1
55	W	IGN COIL
56	SB	A/C COMP
57	R	ETC
58	GR	ECM BAT
59	L	ENG SOL
60	LG	INJECTOR #2
61	Y	AT ECU

Connector No.	F17
Connector Name	IPDM E/R (INTELLIGENT POWER DISTRIBUTION MODULE ENGINE ROOM)
Connector Color	BLACK



Terminal No.	Color of Wire	Signal Name
51	W	STARTER MOTOR

ABMIA4796GB

U1000 CAN COMM CIRCUIT

< DTC/CIRCUIT DIAGNOSIS >

[IPDM E/R]

DTC/CIRCUIT DIAGNOSIS

U1000 CAN COMM CIRCUIT

Description

INFOID:000000009130992

Refer to [LAN-17, "CAN COMMUNICATION SYSTEM : System Description"](#).

DTC Logic

INFOID:000000009130993

DTC DETECTION LOGIC

CONSULT Display	DTC Detection Condition	Possible Cause
CAN COMM CIRCUIT [U1000]	When IPDM E/R cannot communicate with CAN communication signal continuously for 2 seconds or more	In CAN communication system, any item (or items) of the following listed below is malfunctioning. <ul style="list-style-type: none">• Transmission• Receiving (ECM)• Receiving (BCM)• Receiving (Combination meter)

DTC CONFIRMATION PROCEDURE

Diagnosis Procedure

INFOID:000000009130994

1. PERFORM SELF DIAGNOSTIC

1. Turn ignition switch ON and wait for 2 second or more.
2. Check "SELF-DIAG RESULTS" of IPDM E/R.

Is "CAN COMM CIRCUIT" displayed?

- YES >> Refer to [LAN-26, "Trouble Diagnosis Flow Chart"](#).
NO >> Refer to [GI-53, "Intermittent Incident"](#).

A
B
C
D
E
F
G
H
I
J
K
L
N
O
P

PCS

U1010 CONTROL UNIT (CAN)

< DTC/CIRCUIT DIAGNOSIS >

[IPDM E/R]

U1010 CONTROL UNIT (CAN)

DTC Logic

INFOID:000000009130995

DTC DETECTION LOGIC

CONSULT Display	DTC Detection Condition	Possible Cause
CAN COMM CIRCUIT [U1010]	IPDM E/R detected internal CAN communication circuit malfunction.	IPDM E/R

Diagnosis Procedure

INFOID:000000009130996

1. REPLACE IPDM E/R

When DTC U1010 is detected, replace IPDM E/R.

>> Replace IPDM E/R. Refer to [PCS-32. "Removal and Installation"](#).

B2098 IGNITION RELAY ON STUCK

< DTC/CIRCUIT DIAGNOSIS >

[IPDM E/R]

B2098 IGNITION RELAY ON STUCK

Description

INFOID:000000009130997

- IPDM E/R operates the ignition relay when it receives an ignition switch ON signal from BCM via CAN communication.
- Turn the ignition relay OFF by pressing the push-button ignition switch once when the vehicle speed is 4 km/h (2.5 MPH) or less.
- Turn the ignition relay OFF with the following operation when the vehicle speed is more than 4 km/h (2.5 MPH) or when an abnormal condition occurs in CAN communication from the combination meter (Emergency OFF)
 - Press and hold the push-button ignition switch for 2 seconds or more.
 - Press the push-button ignition switch 3 times within 1.5 seconds.

NOTE:

The ignition relay does not turn ON for 3 seconds after emergency OFF even if the push-button ignition switch is pressed.

DTC Logic

INFOID:000000009130998

DTC DETECTION LOGIC

CONSULT Display	DTC Detection Condition	Possible Cause
IGN RELAY ON [B2098]	The ignition relay ON is detected for 1 second at ignition switch OFF (CPU monitors the status at the contact and excitation coil circuits of the ignition relay inside it)	Ignition relay malfunction

Diagnosis Procedure

INFOID:000000009130999

1. PERFORM SELF DIAGNOSIS

1. Turn the ignition switch ON.
2. Erase "SELF-DIAG RESULTS" of IPDM E/R.
3. Turn ignition switch OFF, and wait for 1 second or more.
4. Turn the ignition switch ON. Check "SELF-DIAG RESULTS" again.

Is "IGN RELAY ON" displayed?

- YES >> Replace IPDM E/R. Refer to [PCS-32, "Removal and Installation"](#).
NO >> Refer to [GI-53, "Intermittent Incident"](#).

A
B
C
D
E
F
G
H
I
J
K
L
N
O
P

PCS

B2099 IGNITION RELAY OFF STUCK

< DTC/CIRCUIT DIAGNOSIS >

[IPDM E/R]

B2099 IGNITION RELAY OFF STUCK

Description

INFOID:000000009131000

- IPDM E/R operates the ignition relay when it receives an ignition switch ON signal from BCM via CAN communication.
- Turn the ignition relay OFF by pressing the push-button ignition switch once when the vehicle speed is 4 km/h (2.5 MPH) or less.
- Turn the ignition relay OFF with the following operation when the vehicle speed is more than 4 km/h (2.5 MPH) or when an abnormal condition occurs in CAN communication from the combination meter (Emergency OFF)
 - Press and hold the push-button ignition switch for 2 seconds or more.
 - Press the push-button ignition switch 3 times within 1.5 seconds.

NOTE:

The ignition relay does not turn ON for 3 seconds after emergency OFF even if the push-button ignition switch is pressed.

DTC Logic

INFOID:000000009131001

DTC DETECTION LOGIC

CONSULT Display	DTC Detection Condition	Possible Cause
IGN RELAY OFF [B2099]	The ignition relay OFF is detected for 1 second at ignition switch ON (CPU monitors the status at the contact and excitation coil circuits of the ignition relay inside it)	Ignition relay malfunction

Diagnosis Procedure

INFOID:000000009131002

1. PERFORM SELF DIAGNOSIS

1. Turn the ignition switch ON.
2. Erase "SELF-DIAG RESULTS".
3. Turn ignition switch OFF.
4. Turn the ignition switch ON. Check "SELF-DIAG RESULTS" again.

Is "IGN RELAY OFF" displayed?

- YES >> Replace IPDM E/R. Refer to [PCS-32, "Removal and Installation"](#).
NO >> Refer to [GI-53, "Intermittent Incident"](#).

POWER SUPPLY AND GROUND CIRCUIT

< DTC/CIRCUIT DIAGNOSIS >

[IPDM E/R]

POWER SUPPLY AND GROUND CIRCUIT

Diagnosis Procedure

INFOID:000000009131003

Regarding Wiring Diagram information, refer to [PCS-21, "Wiring Diagram"](#).

1. CHECK FUSIBLE LINKS

Check that the following fusible links are not blown.

Terminal No.	Signal name	Fusible link No.
1	Fusible link main	E (80A)
2	Fusible link IPDM E/R	A (250A), C (80A)
3	Fusible link ignition switch	A (250A), B (100A), K (40A)

Is the fusible link blown?

YES >> Replace the blown fusible link after repairing the affected circuit.

NO >> GO TO 2

2. CHECK POWER SUPPLY CIRCUIT

1. Disconnect IPDM E/R connectors E118 and E120.
2. Check voltage between IPDM E/R connectors and ground.

IPDM E/R		Ground	Voltage (Approx.)
Connector	Terminal		
E118	1	—	Battery voltage
	2		
E120	3		

Is the inspection result normal?

YES >> GO TO 3

NO >> Repair or replace harness or connectors.

3. CHECK GROUND CIRCUIT

1. Disconnect IPDM E/R connectors E119 and E121.
2. Check continuity between IPDM E/R connectors and ground.

IPDM E/R		Ground	Continuity
Connector	Terminal		
E121	7	—	Yes
E119	41		

Is the inspection result normal?

YES >> Inspection End.

NO >> Repair or replace harness or connectors.

A
B
C
D
E
F
G
H
I
J
K
L
N
O
P

PCS

REMOVAL AND INSTALLATION

IPDM E/R (INTELLIGENT POWER DISTRIBUTION MODULE ENGINE ROOM)

Removal and Installation

INFOID:000000009131004

CAUTION:

IPDM E/R integrated relays are not serviceable parts, and must not be removed from the unit.

REMOVAL

1. Disconnect the negative battery terminal. Refer to [PG-93. "Removal and Installation"](#).
2. Release the pawls (A) and separate the IPDM E/R (1) from the case.

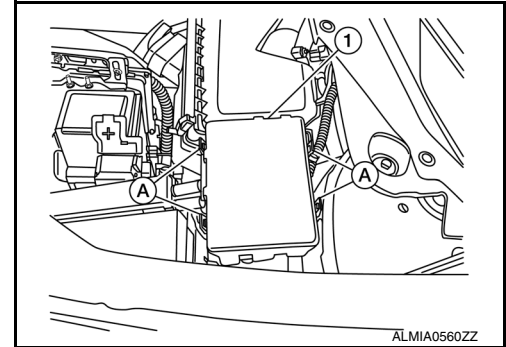

3. Disconnect all harness connectors (1) from the IPDM E/R (2) and remove.

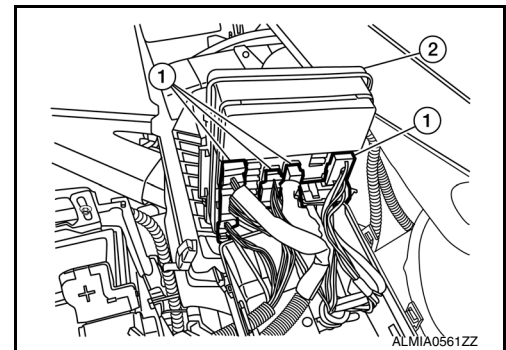

INSTALLATION

Installation is in the reverse order of removal.

PRECAUTION

PRECAUTIONS

Precaution for Supplemental Restraint System (SRS) "AIR BAG" and "SEAT BELT PRE-TENSIONER"

INFOID:000000009131005

The Supplemental Restraint System such as "AIR BAG" and "SEAT BELT PRE-TENSIONER", used along with a front seat belt, helps to reduce the risk or severity of injury to the driver and front passenger for certain types of collision. This system includes dual stage front air bag modules. The SRS system may only deploy one front air bag, depending on the severity of a collision and whether the front passenger seat is occupied. Information necessary to service the system safely is included in the SR and SB section of this Service Manual.

WARNING:

- To avoid rendering the SRS inoperative, which could increase the risk of personal injury or death in the event of a collision which would result in air bag inflation, all maintenance must be performed by an authorized NISSAN/INFINITI dealer.
- Improper maintenance, including incorrect removal and installation of the SRS, can lead to personal injury caused by unintentional activation of the system. For removal of Spiral Cable and Air Bag Module, see the SR section.
- Do not use electrical test equipment on any circuit related to the SRS unless instructed to in this Service Manual. SRS wiring harnesses can be identified by yellow and/or orange harnesses or harness connectors.

PRECAUTIONS WHEN USING POWER TOOLS (AIR OR ELECTRIC) AND HAMMERS

WARNING:

- When working near the Airbag Diagnosis Sensor Unit or other Airbag System sensors with the Ignition ON or engine running, DO NOT use air or electric power tools or strike near the sensor(s) with a hammer. Heavy vibration could activate the sensor(s) and deploy the air bag(s), possibly causing serious injury.
- When using air or electric power tools or hammers, always switch the Ignition OFF, disconnect the battery and wait at least three minutes before performing any service.

Precaution for Work

INFOID:000000009131006

- When removing or disassembling each component, be careful not to damage or deform it. If a component may be subject to interference, be sure to protect it with a shop cloth.
- When removing (disengaging) components with a screwdriver or similar tool, be sure to wrap the component with a shop cloth or vinyl tape to protect it.
- Protect the removed parts with a shop cloth and prevent them from being dropped.
- Replace a deformed or damaged clip.
- If a part is specified as a non-reusable part, always replace it with a new one.
- Be sure to tighten bolts and nuts securely to the specified torque.
- After installation is complete, be sure to check that each part works properly.
- Follow the steps below to clean components:
 - Water soluble dirt:
 - Dip a soft cloth into lukewarm water, wring the water out of the cloth and wipe the dirty area.
 - Then rub with a soft, dry cloth.
 - Oily dirt:
 - Dip a soft cloth into lukewarm water with mild detergent (concentration: within 2 to 3%) and wipe the dirty area.
 - Then dip a cloth into fresh water, wring the water out of the cloth and wipe the detergent off.
 - Then rub with a soft, dry cloth.
 - Do not use organic solvent such as thinner, benzene, alcohol or gasoline.
 - For genuine leather seats, use a genuine leather seat cleaner.

A
B
C
D
E
F
G
H
I
J
K
L
N
O
P

PCS

PREPARATION

< PREPARATION >

[POWER DISTRIBUTION SYSTEM]

PREPARATION

PREPARATION

Special Service Tool

INFOID:000000009131007

The actual shapes of Kent-Moore tools may differ from those of special service tools illustrated here.

Tool number (Kent-Moore No.) Tool name	Description
— (J-46534) Trim Tool Set	Removing trim components

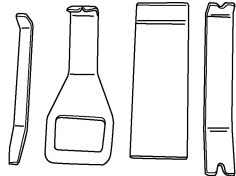

AWJIA0483ZZ

COMPONENT PARTS

< SYSTEM DESCRIPTION >

[POWER DISTRIBUTION SYSTEM]

SYSTEM DESCRIPTION

COMPONENT PARTS

Component Parts Location

INFOID:000000009131008

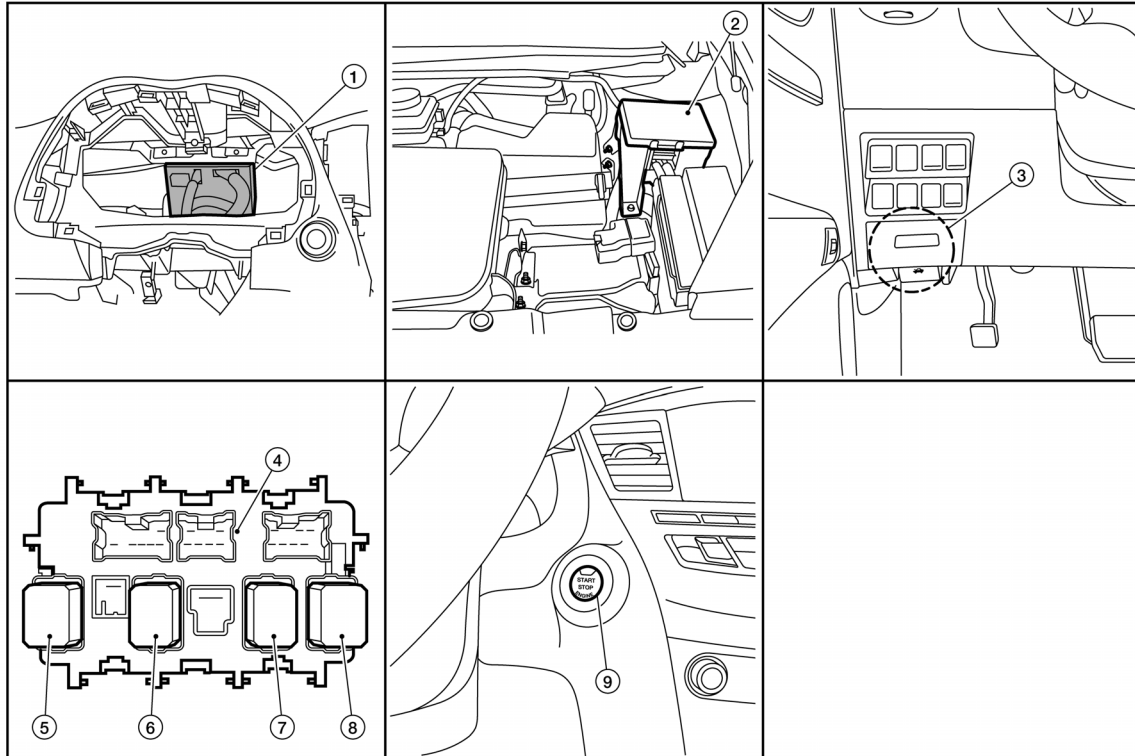

ALMIA0563ZZ

- | | | |
|---------------------------------------|---|--------------------------------|
| 1. BCM | 2. IPDM E/R (contains Ignition relay-1) | 3. Fuse block (J/B) |
| 4. Fuse block (J/B) (back side shown) | 5. Ignition relay-2 | 6. Front blower motor relay |
| 7. Rear window defogger relay | 8. Accessory relay-1 | 9. Push-button ignition switch |

A
B
C
D
E
F
G
H
I
J
K
L
N
O
P

PCS

SYSTEM

POWER DISTRIBUTION SYSTEM

POWER DISTRIBUTION SYSTEM : System Diagram

INFOID:000000009131009

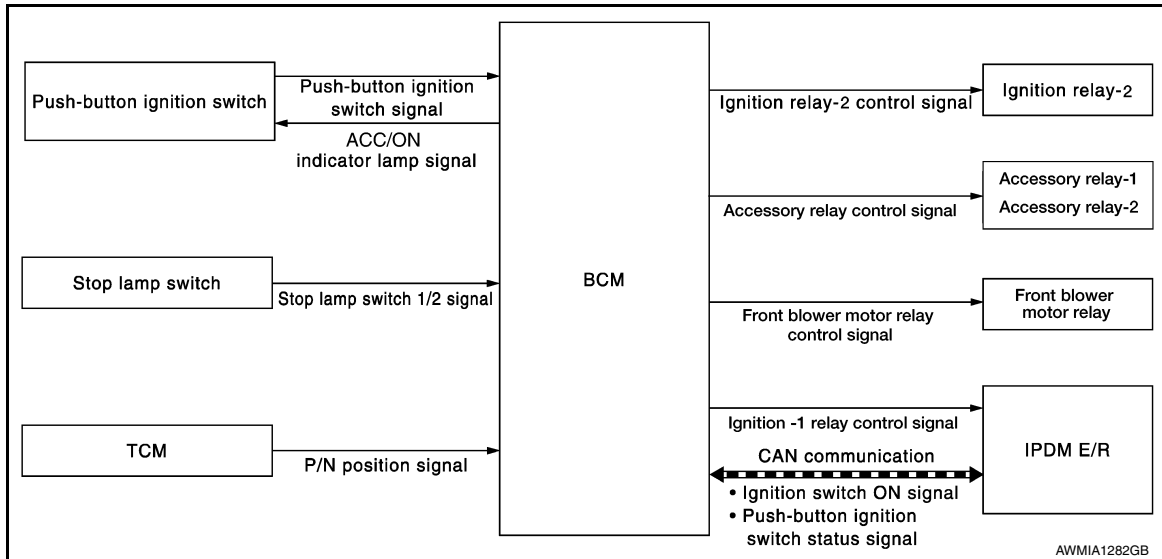

POWER DISTRIBUTION SYSTEM : System Description

INFOID:000000009131010

SYSTEM DESCRIPTION

- PDS (POWER DISTRIBUTION SYSTEM) is the system that BCM controls with the operation of the push-button ignition switch and performs the power distribution to each power circuit. This system is used instead of the mechanical power supply changing mechanism with the operation of the conventional key cylinder.
- The push-button ignition switch can be operated when Intelligent Key is in the following condition.
 - Intelligent Key is in the detection area of the inside key antenna.
 - Intelligent Key backside is contacted to push-button ignition switch.
- The push-button ignition switch operation is input to BCM as a signal. BCM changes the power supply position according to the status and operates the following relays to supply power to each power circuit.
 - Ignition relay-1
 - Ignition relay-2
 - Accessory relay-1
 - Accessory relay-2
 - Front blower motor relay

NOTE:

- The engine switch operation changes due to the conditions of brake pedal, selector lever and vehicle speed.
- The power supply position can be confirmed with the lighting of the indicators in the push-button ignition switch.

BATTERY SAVER SYSTEM

When all the following conditions are met for 30 minutes, the battery saver system will cut off the power supply to prevent battery discharge.

- The ignition switch is in the ACC or ON position
- All doors are closed
- Selector lever is in the P (park) position

Reset Condition of Battery Saver System

In order to prevent the battery from discharging, the battery saver system will cut off the power supply when all doors are closed, the selector lever is in P (park) position and the ignition switch is left in the ACC or ON position for 30 minutes. If any of the following conditions are met the battery saver system is released and the steering will change automatically to lock position from OFF position.

- Opening any door
- Operating door request switch on door handle
- Operating Intelligent Key

SYSTEM

[POWER DISTRIBUTION SYSTEM]

< SYSTEM DESCRIPTION >

POWER SUPPLY POSITION CHANGE TABLE BY PUSH-BUTTON IGNITION SWITCH OPERATION

The power supply position changing operation can be performed with the following operations.

NOTE:

- When an Intelligent Key is within the detection area of inside key antenna and when Intelligent Key backside is contacted to push-button ignition switch, it is equivalent to the operations below.
- When starting the engine, the BCM monitors under the engine start conditions:
 - Brake pedal operating condition
 - Selector lever position
 - Vehicle speed

Vehicle speed: less than 4 km/h (2.5 MPH)

Power supply position	Engine start/stop condition		Push-button ignition switch operation frequency
	Selector lever position	Brake pedal operation condition	
OFF → ACC	—	Not depressed	1
OFF → ACC → ON	—	Not depressed	2
OFF → ACC → ON → OFF	—	Not depressed	3
OFF → START ACC → START ON → START	P or N position	Depressed	1
Engine is running → OFF	—	—	1

Vehicle speed: 4 km/h (2.5 MPH) or more

Power supply position	Engine start/stop condition		Push-button ignition switch operation frequency
	Selector lever position	Brake pedal operation condition	
Engine is running → ACC	—	—	Emergency stop operation
Engine stall return operation while driving	N position	Not depressed	1

Emergency stop operation

- Press and hold the push-button ignition switch for 2 seconds or more.
- Press the push-button ignition switch 3 times or more within 1.5 seconds.

A
B
C
D
E
F
G
H
I
J
K
L

PCS

N
O
P

DIAGNOSIS SYSTEM (BCM)

< SYSTEM DESCRIPTION >

[POWER DISTRIBUTION SYSTEM]

DIAGNOSIS SYSTEM (BCM)

COMMON ITEM

COMMON ITEM : CONSULT Function (BCM - COMMON ITEM)

INFOID:000000009725722

CAUTION:

After disconnecting the CONSULT vehicle interface (VI) from the data link connector, the ignition must be cycled OFF → ON (for at least 5 seconds) → OFF. If this step is not performed, the BCM may not go to "sleep mode", potentially causing a discharged battery and no-start condition.

APPLICATION ITEM

CONSULT performs the following functions via CAN communication with BCM.

Direct Diagnostic Mode	Description
Ecu Identification	The BCM part number is displayed.
Self Diagnostic Result	The BCM self diagnostic results are displayed.
Data Monitor	The BCM input/output data is displayed in real time.
Active Test	The BCM activates outputs to test components.
Work support	The settings for BCM functions can be changed.
Configuration	<ul style="list-style-type: none"> The vehicle specification can be read and saved. The vehicle specification can be written when replacing BCM.
CAN Diag Support Mntr	The result of transmit/receive diagnosis of CAN communication is displayed.

SYSTEM APPLICATION

BCM can perform the following functions.

System	Sub System	Direct Diagnostic Mode						
		Ecu Identification	Self Diagnostic Result	Data Monitor	Active Test	Work support	Configuration	CAN Diag Support Mntr
Door lock	DOOR LOCK		×	×	×	×		
Rear window defogger	REAR DEFOGGER			×	×	×		
Warning chime	BUZZER			×	×			
Interior room lamp timer	INT LAMP			×	×	×		
Exterior lamp	HEADLAMP			×	×	×		
Wiper and washer	WIPER			×	×	×		
Turn signal and hazard warning lamps	FLASHER			×	×			
Air conditioner	AIR CONDITIONER			×				
Intelligent Key system	INTELLIGENT KEY		×	×	×	×		
Combination switch	COMB SW			×				
BCM	BCM	×	×			×	×	×
Immobilizer	IMMU		×	×	×			
Interior room lamp battery saver	BATTERY SAVER			×	×			
Back door open	TRUNK			×				
Vehicle security system	THEFT ALM			×	×	×		
RAP system	RETAINED PWR			×				

DIAGNOSIS SYSTEM (BCM)

< SYSTEM DESCRIPTION >

[POWER DISTRIBUTION SYSTEM]

System	Sub System	Direct Diagnostic Mode						
		Ecu Identification	Self Diagnostic Result	Data Monitor	Active Test	Work support	Configuration	CAN Diag Support Mntr
Signal buffer system	SIGNAL BUFFER			×				
TPMS	AIR PRESSURE MONITOR		×	×	×	×		

INTELLIGENT KEY

INTELLIGENT KEY : CONSULT Function (BCM - INTELLIGENT KEY)

INFOID:000000009725723

CAUTION:

After disconnecting the CONSULT vehicle interface (VI) from the data link connector, the ignition must be cycled OFF → ON (for at least 5 seconds) → OFF. If this step is not performed, the BCM may not go to "sleep mode", potentially causing a discharged battery and no-start condition.

SELF DIAGNOSTIC RESULT

Refer to [BCS-51, "DTC Index"](#).

DATA MONITOR

Monitor Item [Unit]	Main	Description
REQ SW -DR [On/Off]	×	Indicates condition of door request switch LH.
REQ SW -AS [On/Off]	×	Indicates condition of door request switch RH.
REQ SW -BD/TR [On/Off]	×	Indicates condition of back door request switch.
PUSH SW [On/Off]		Indicates condition of push-button ignition switch.
SHIFTLOCK SOLENOID PWR SUPPLY [On/Off]	×	Indicates condition of power supply to shiftlock solenoid.
BRAKE SW 1 [On/Off]	×	Indicates condition of brake switch.
BRAKE SW 2 [On/Off]		Indicates condition of brake switch.
DETE/CANCL SW [On/Off]	×	Indicates condition of P (park) position.
SFT PN/N SW [On/Off]	×	Indicates condition of P (park) or N (neutral) position.
UNLK SEN -DR [On/Off]	×	Indicates condition of door unlock sensor.
PUSH SW -IPDM [On/Off]		Indicates condition of push-button ignition switch received from IPDM E/R on CAN communication line.
IGN RLY1 -F/B [On/Off]		Indicates condition of ignition relay 1 received from IPDM E/R on CAN communication line.
DETE SW -IPDM [On/Off]		Indicates condition of detent switch received from TCM on CAN communication line.
SFT PN -IPDM [On/Off]		Indicates condition of P (park) or N (neutral) position from TCM on CAN communication line.
SFT P -MET [On/Off]		Indicates condition of P (park) position from TCM on CAN communication line.
SFT N -MET [On/Off]		Indicates condition of N (neutral) position from IPDM E/R on CAN communication line.
ENGINE STATE [Stop/Start/Crank/Run]	×	Indicates condition of engine state from ECM on CAN communication line.
VEH SPEED 1 [mph/km/h]	×	Indicates condition of vehicle speed signal received from ABS on CAN communication line.
VEH SPEED 2 [mph/km/h]	×	Indicates condition of vehicle speed signal received from combination meter on CAN communication line.

A
B
C
D
E
F
G
H
I
J
K
L
N
O
P

PCS

DIAGNOSIS SYSTEM (BCM)

< SYSTEM DESCRIPTION >

[POWER DISTRIBUTION SYSTEM]

Monitor Item [Unit]	Main	Description
DOOR STAT -DR [LOCK/READY/UNLK]	×	Indicates condition of driver side door status.
DOOR STAT -AS [LOCK/READY/UNLK]	×	Indicates condition of passenger side door status.
DOOR STAT -RR [LOCK/READY/UNLK]	×	Indicates condition of rear right side door status.
DOOR STAT -RL [LOCK/READY/UNLK]	×	Indicates condition of rear left side door status.
BK DOOR STATE [LOCK/READY/UNLK]	×	Indicates condition of back door status.
ID OK FLAG [Set/Reset]		Indicates condition of Intelligent Key ID.
PRMT ENG STRT [Set/Reset]		Indicates condition of engine start possibility.
PRMT RKE STRT [Set/Reset]		Indicates condition of engine start possibility from Intelligent Key.
I-KEY OK FLAG [Key ON/Key OFF]	×	Indicates condition of Intelligent Key OK flag.
PRBT ENG STRT [Set/Reset]		Indicates condition of engine start prohibit.
ID AUTHENTICATION CANCEL TIMER [under a stop]		Indicates condition of Intelligent Key ID authentication.
ACC BATTERY SAVER [under a stop]		Indicates condition of battery saver.
CRNK PRBT TMR [On/Off]		Indicates condition of crank prohibit timer.
AUT CRNK TMR [On/Off]		Indicates condition of automatic engine crank timer from Intelligent Key.
CRNK PRBT TME [sec]		Indicates condition of engine crank prohibit time.
CRANKING TME [sec]		Indicates condition of engine cranking time from Intelligent Key.
DETE SW PWR [On/Off]		Indicates condition of detent switch voltage.
ACC RLY -REQ [On/Off]		Indicates condition of accessory relay control request.
RKE OPE COUN1 [0-19]	×	When remote keyless entry receiver receives the signal transmitted while operating on Intelligent Key, the numerical value start changing.
RKE OPE COUN2 [0-19]	×	When remote keyless entry receiver receives the signal transmitted while operating on Intelligent Key, the numerical value start changing.
TRNK/HAT MNTR [On/Off]		Indicates condition of trunk room lamp switch.
RKE-LOCK [On/Off]		Indicates condition of lock signal from Intelligent Key.
RKE-UNLOCK [On/Off]		Indicates condition of unlock signal from Intelligent Key.
RKE-TR/BD [On/Off]		Indicates condition of back door open signal from Intelligent Key.
RKE-PANIC [On/Off]		Indicates condition of panic signal from Intelligent Key.
RKE-MODE CHG [On/Off]		Indicates condition of mode change signal from Intelligent Key.

ACTIVE TEST

Test Item	Description
INTELLIGENT KEY LINK (CAN)	This test is able to check Intelligent Key identification number [Off/ID No1/ID No2/ID No3/ID No4/ID No5].
INT LAMP	This test is able to check interior room lamp operation [On/Off].
FLASHER	This test is able to check hazard lamp operation [LH/RH/Off].
HORN	This test is able to check horn operation [On].
BATTERY SAVER	This test is able to check battery saver operation [On/Off].
TRUNK/BACK DOOR	This test is able to check back door actuator operation [Open].
OUTSIDE BUZZER	This test is able to check Intelligent Key warning buzzer operation [On/Off].
INSIDE BUZZER	This test is able to check combination meter warning chime operation [Take Out/Knob/Key/Off].
INDICATOR	This test is able to check combination meter warning lamp operation [KEY ON/KEY IND/Off].
IGN CONT2	This test is able to check ignition relay-2 control operation [On/Off].
ENGINE SW ILLUMI	This test is able to check push-button ignition switch START indicator operation [On/Off].
PUSH SWITCH INDICATOR	This test is able to check push-button ignition switch indicator operation [On/Off].

DIAGNOSIS SYSTEM (BCM)

[POWER DISTRIBUTION SYSTEM]

< SYSTEM DESCRIPTION >

Test Item	Description
ACC CONT	This test is able to check accessory relay control operation [On/Off].
IGN CONT1	This test is able to check ignition relay-1 control operation [On/Off].
ST CONT LOW	This test is able to check starter control relay operation [On/Off].
IGNITION RELAY	This test is able to check ignition relay operation [On/Off].
REVERSE LAMP TEST	This test is able to check reverse lamp illumination operation [On/Off].
DOOR HANDLE LAMP TEST	This test is able to check door handle lamp illumination operation [On/Off].
TRUNK/LUGGAGE LAMP TEST	This test is able to check cargo lamp illumination operation [On/Off].
KEYFOB PW TEST	This test is able to check power window operation using the Intelligent Key [P/W up/down OFF/Send P/W down ON/Send P/W up ON].
SHIFTLOCK SOLENOID TEST	This test is able to check shift lock solenoid operation [On/Off].

WORK SUPPORT

Support Item	Setting	Description
IGN/ACC Battery Saver	On*	Battery saver function ON.
	Off	Battery saver function OFF.
REMOTE ENGINE STARTER	On*	Remote engine start function ON.
	Off	Remote engine start function OFF.
ANSWERBACK I-KEY LOCK UNLOCK	BUZZER	Buzzer reminder function by door lock/unlock request switch ON.
	HORN	Horn chirp reminder function by door lock request switch ON.
	Off*	No reminder function by door lock/unlock request switch.
	INVALID	This mode is not used.
ANSWERBACK KEYLESS LOCK UNLOCK	On	Buzzer or horn chirp reminder when doors are locked/unlocked with Intelligent Key.
	Off*	No buzzer or horn chirp reminder when doors are locked/unlocked with Intelligent Key.
WELCOME LIGHT OP SET	On*	Door handle lamp function from request switch ON.
	Off	Door handle lamp function from request switch OFF.
ANSWER BACK	On*	Horn chirp reminder when doors are locked with Intelligent Key.
	Off	No horn chirp reminder when doors are locked with Intelligent Key.
RETRACTABLE MIRROR SET	On	Retractable mirror set ON.
	Off*	Retractable mirror set OFF.
LOCK/UNLOCK BY I-KEY	On*	Door lock/unlock function from Intelligent Key ON.
	Off	Door lock/unlock function from Intelligent Key OFF.
ENGINE START BY I-KEY	On*	Engine start function from Intelligent Key ON.
	Off	Engine start function from Intelligent Key OFF.
TRUNK/GLASS HATCH OPEN	On*	Buzzer reminder function by back door request switch ON.
	Off	Buzzer reminder function by back door request switch OFF.
INTELLIGENT KEY LINK SET	On	Intelligent Key link set ON.
	Off*	Intelligent Key link set OFF.
CONFIRM KEY FOB ID	—	Intelligent Key ID code can be checked.
SHORT CRANKING OUTPUT	Start	70 msec
		100 msec
		200 msec
End	—	
INSIDE ANT DIAGNOSIS	—	This function allows inside key antenna self-diagnosis.

DIAGNOSIS SYSTEM (BCM)

[POWER DISTRIBUTION SYSTEM]

< SYSTEM DESCRIPTION >

Support Item	Setting		Description
AUTO LOCK SET	MODE7	5 min	Auto door lock time can be set in this mode.
	MODE6	4 min	
	MODE5	3 min	
	MODE4	2 min	
	MODE3*	1 min	
	MODE2	30 sec	
	MODE1	Off	

*: Initial Setting

ECU DIAGNOSIS INFORMATION

BCM, IPDM E/R

List of ECU Reference

INFOID:000000009131013

ECU	Reference
BCM	BCS-29, "Reference Value"
	BCS-49, "Fail Safe"
	BCS-49, "DTC Inspection Priority Chart"
	BCS-51, "DTC Index"
IPDM E/R	PCS-12, "Reference Value"
	PCS-19, "Fail Safe"
	PCS-20, "DTC Index"

A
B
C
D
E
F
G
H
I
J
K
L
N
O
P

PCS

POWER DISTRIBUTION SYSTEM

< WIRING DIAGRAM >

[POWER DISTRIBUTION SYSTEM]

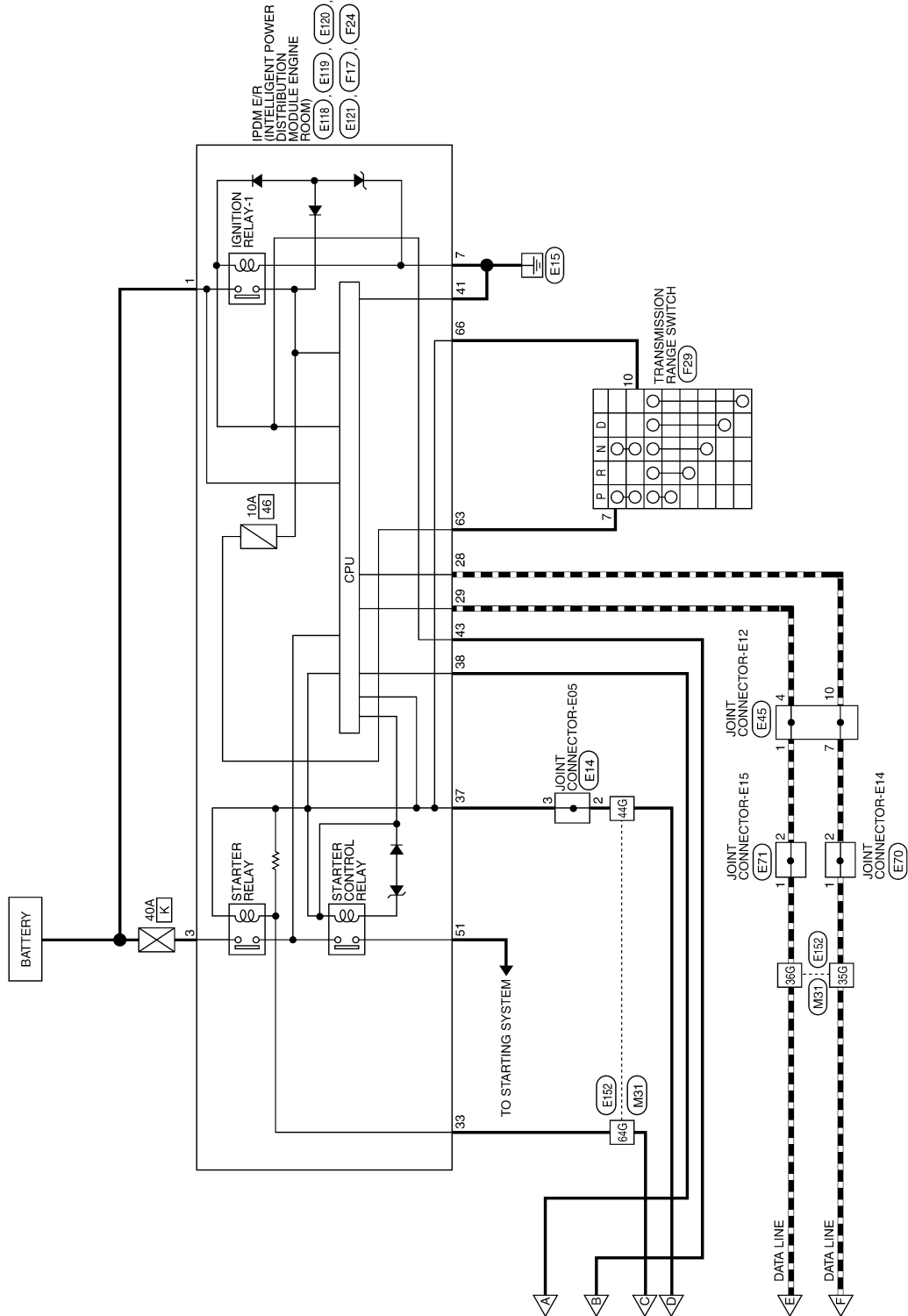

ABMWA2083GB

A
B
C
D
E
F
G
H
I
J
K
L
PCS
N
O
P

POWER DISTRIBUTION SYSTEM

< WIRING DIAGRAM >

[POWER DISTRIBUTION SYSTEM]

POWER DISTRIBUTION SYSTEM CONNECTORS

Connector No.	M3
Connector Name	FUSE BLOCK (J/B)
Connector Color	WHITE

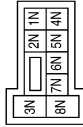

Terminal No.	Color of Wire	Signal Name
1N	LG	-
2N	BG	-
3N	L	-
6N	W	-
7N	L	-
8N	L	-

Connector No.	M4
Connector Name	FUSE BLOCK (J/B)
Connector Color	WHITE



Terminal No.	Color of Wire	Signal Name
3P	G	-
7P	LG	-
9P	L	-
16P	W	-

Connector No.	M17
Connector Name	PUSH-BUTTON IGNITION SWITCH
Connector Color	WHITE

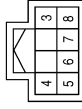

Terminal No.	Color of Wire	Signal Name
3	BG	-
4	B	-
5	R	-
6	W	-
7	P	-
8	G	-

Connector No.	M19
Connector Name	BCM (BODY CONTROL MODULE)
Connector Color	BLACK

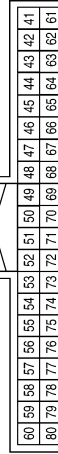

Terminal No.	Color of Wire	Signal Name
48	R	HIGH SIDE START SW LED
59	P	CAN-L
60	L	CAN-H
62	W	STARTER RELAY OUT
66	W	BLOWER FAN RELAY OUT
67	G	IGN ELEC RELAY OUT 2
70	P	IGN USM OUT 1

Connector No.	M18
Connector Name	BCM (BODY CONTROL MODULE)
Connector Color	GREEN

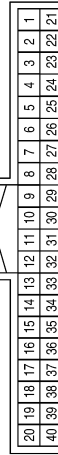

Terminal No.	Color of Wire	Signal Name
1	G	ENG START SW
25	W	BRAKE SW FUSE
26	L	SHORTING INPUT
27	G	BRAKE SW LAMP
39	G	SHIFT N/P

ABMIA4797GB

POWER DISTRIBUTION SYSTEM

< WIRING DIAGRAM >

[POWER DISTRIBUTION SYSTEM]

Connector No.	M41
Connector Name	JOINT CONNECTOR-M18
Connector Color	WHITE



Terminal No.	Color of Wire	Signal Name
1	P	-
2	P	-

Connector No.	M40
Connector Name	WIRE TO WIRE
Connector Color	GRAY

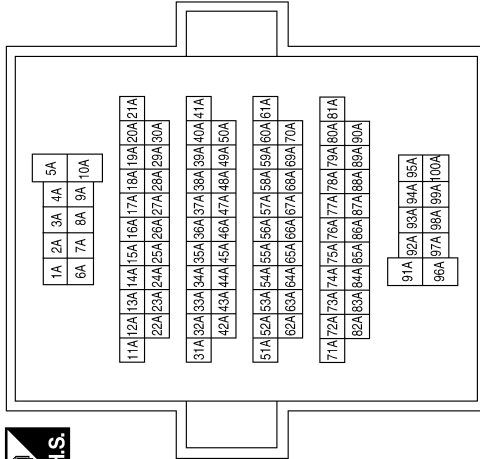

Terminal No.	Color of Wire	Signal Name
89A	L	-
90A	P	-

Connector No.	M31
Connector Name	WIRE TO WIRE
Connector Color	WHITE

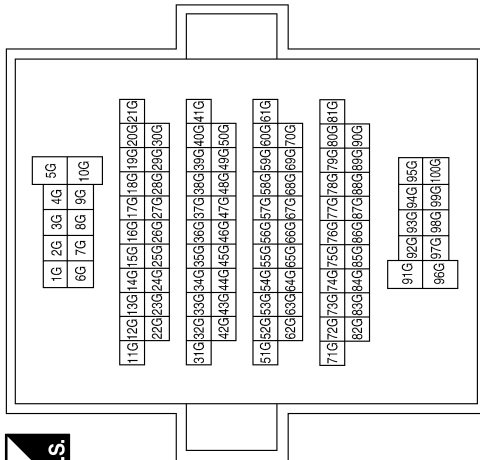

Terminal No.	Color of Wire	Signal Name
3G	P	-
10G	W	-
35G	P	-
36G	L	-
44G	G	-
50G	L	-
62G	G	-
63G	P	-
64G	W	-

ABMIA4798GB

A
B
C
D
E
F
G
H
I
J
K
L
N
O
P

PCS

POWER DISTRIBUTION SYSTEM

< WIRING DIAGRAM >

[POWER DISTRIBUTION SYSTEM]

Connector No.	M80
Connector Name	BCM (BODY CONTROL MODULE)
Connector Color	BLACK

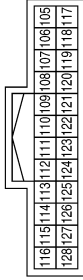

Terminal No.	Color of Wire	Signal Name
107	W	LOW SIDE START SW LED
111	P	ACC LED
113	L	ACC RELAY OUT

Connector No.	M181
Connector Name	JOINT CONNECTOR-M36
Connector Color	WHITE



Terminal No.	Color of Wire	Signal Name
1	W	-
2	W	-

Connector No.	M68
Connector Name	FUSE BLOCK (J/B)
Connector Color	BROWN



Terminal No.	Color of Wire	Signal Name
6R	Y	-
9R	G	-
10R	W	-
13R	GR	-
16R	BG	-

Connector No.	M84
Connector Name	WIRE TO WIRE
Connector Color	WHITE

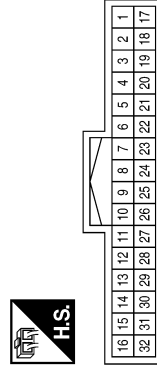

Terminal No.	Color of Wire	Signal Name
17	L	-
18	P	-

Connector No.	M43
Connector Name	JOINT CONNECTOR-M17
Connector Color	WHITE



Terminal No.	Color of Wire	Signal Name
1	L	-
2	L	-

Connector No.	M81
Connector Name	BCM (BODY CONTROL MODULE)
Connector Color	WHITE

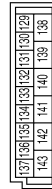

Terminal No.	Color of Wire	Signal Name
131	W	BAT BCM FUSE
134	B	GND 2
139	W	BAT POWER F/L
143	B	GND 1

ABMIA4799GB

POWER DISTRIBUTION SYSTEM

[POWER DISTRIBUTION SYSTEM]

< WIRING DIAGRAM >

Connector No.	E28
Connector Name	FUSE BLOCK (J/B)
Connector Color	WHITE

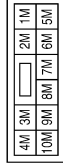

Terminal No.	Color of Wire	Signal Name
1M	R	-
5M	Y	-
7M	P	-

Connector No.	E22
Connector Name	ACCESSORY RELAY-2
Connector Color	BLUE



Terminal No.	Color of Wire	Signal Name
1	G	-
2	B	-
3	R	-
5	P	-

Connector No.	E14
Connector Name	JOINT CONNECTOR-E05
Connector Color	BLACK

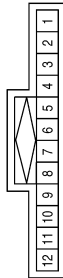

Terminal No.	Color of Wire	Signal Name
2	W	-
3	W	-

Connector No.	E45
Connector Name	JOINT CONNECTOR-E12
Connector Color	BLUE

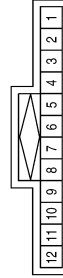

Terminal No.	Color of Wire	Signal Name
1	L	-
4	L	-
7	P	-
10	P	-

Connector No.	E44
Connector Name	JOINT CONNECTOR-E01
Connector Color	WHITE

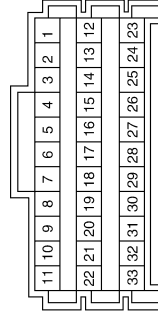

Terminal No.	Color of Wire	Signal Name
12	P	-
13	P	-
15	GR	-
17	B	-
19	Y	-
20	Y	-

Connector No.	E38
Connector Name	STOP LAMP SWITCH
Connector Color	WHITE



Terminal No.	Color of Wire	Signal Name
1	Y	-
2	P	-

ABMIA4800GB

A
B
C
D
E
F
G
H
I
J
K
L
N
O
P

PCS

POWER DISTRIBUTION SYSTEM

< WIRING DIAGRAM >

[POWER DISTRIBUTION SYSTEM]

Connector No.	E118
Connector Name	IPDM E/R (INTELLIGENT POWER DISTRIBUTION MODULE ENGINE ROOM)
Connector Color	BLACK



Terminal No.	1	Color of Wire	R	Signal Name	F/L MAIN
--------------	---	---------------	---	-------------	----------

Connector No.	E71
Connector Name	JOINT CONNECTOR-E15
Connector Color	BLACK



Terminal No.	1	Color of Wire	L	Signal Name	-
2	L	-	-		

Connector No.	E70
Connector Name	JOINT CONNECTOR-E14
Connector Color	BLACK



Terminal No.	1	Color of Wire	P	Signal Name	-
2	P	-	-		

Connector No.	E121
Connector Name	IPDM E/R (INTELLIGENT POWER DISTRIBUTION MODULE ENGINE ROOM)
Connector Color	WHITE



Terminal No.	7	Color of Wire	B	Signal Name	GND (POWER)
--------------	---	---------------	---	-------------	-------------

Connector No.	E120
Connector Name	IPDM E/R (INTELLIGENT POWER DISTRIBUTION MODULE ENGINE ROOM)
Connector Color	WHITE



Terminal No.	3	Color of Wire	G	Signal Name	F/L IGNSW
--------------	---	---------------	---	-------------	-----------

Connector No.	E119
Connector Name	IPDM E/R (INTELLIGENT POWER DISTRIBUTION MODULE ENGINE ROOM)
Connector Color	WHITE

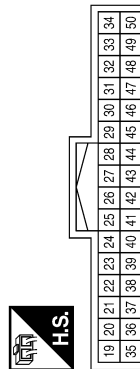

Terminal No.	28	Color of Wire	P	Signal Name	CAN-L
29	L	-	-	CAN-H	
33	R	-	-	START CONT	
37	W	-	-	CLUTCH I/L SW	
38	P	-	-	PUSH START SW	
41	B	-	-	GND (SIGNAL)	
43	L	-	-	IGN SIGNAL	

ABMIA3622GB

POWER DISTRIBUTION SYSTEM

< WIRING DIAGRAM >

[POWER DISTRIBUTION SYSTEM]

Connector No.	F17
Connector Name	IPDM E/R (INTELLIGENT POWER DISTRIBUTION MODULE ENGINE ROOM)
Connector Color	BLACK



Terminal No.	Color of Wire	Signal Name
51	W	STARTER MOTOR

Terminal No.	Color of Wire	Signal Name
3G	P	-
10G	P	-
35G	P	-
36G	L	-
44G	W	-
50G	G	-
62G	P	-
63G	L	-
64G	R	-

Connector No.	E152
Connector Name	WIRE TO WIRE
Connector Color	WHITE

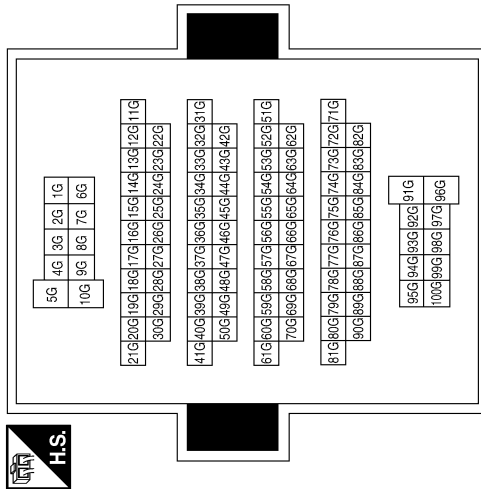

Connector No.	B11
Connector Name	JOINT CONNECTOR-B09
Connector Color	WHITE



Terminal No.	Color of Wire	Signal Name
1	P	-
2	P	-

Connector No.	F29
Connector Name	TRANSMISSION RANGE SWITCH
Connector Color	BLACK

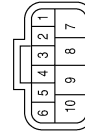

Terminal No.	Color of Wire	Signal Name
7	L	-
10	G	-

Connector No.	F24
Connector Name	IPDM E/R (INTELLIGENT POWER DISTRIBUTION MODULE ENGINE ROOM)
Connector Color	WHITE

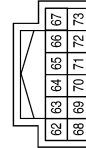

Terminal No.	Color of Wire	Signal Name
63	L	INHIBIT SW
66	G	NP SW

ABMIA4801GB

A
B
C
D
E
F
G
H
I
J
K
L
M
N
O
P

PCS

POWER DISTRIBUTION SYSTEM

< WIRING DIAGRAM >

[POWER DISTRIBUTION SYSTEM]

Connector No.	B17
Connector Name	JOINT CONNECTOR-B12
Connector Color	WHITE



Terminal No.	Color of Wire	Signal Name
1	L	-
2	L	-

Connector No.	B16
Connector Name	JOINT CONNECTOR-B11
Connector Color	WHITE



Terminal No.	Color of Wire	Signal Name
1	P	-
2	P	-

Connector No.	B12
Connector Name	JOINT CONNECTOR-B10
Connector Color	WHITE



Terminal No.	Color of Wire	Signal Name
1	L	-
2	L	-

Connector No.	B69
Connector Name	WIRE TO WIRE
Connector Color	GRAY



Connector No.	B69
Connector Name	WIRE TO WIRE
Connector Color	GRAY

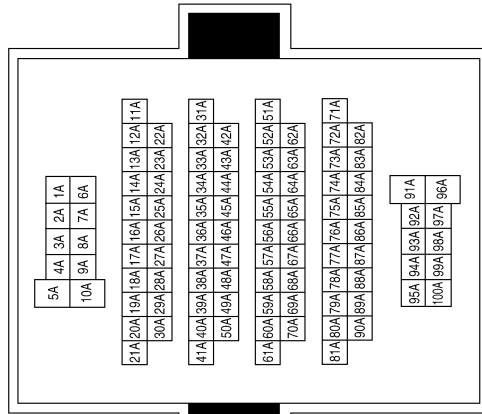

Connector No.	B32
Connector Name	WIRE TO WIRE
Connector Color	WHITE

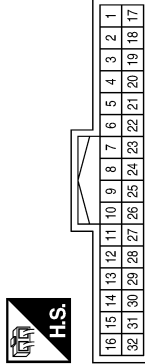

Terminal No.	Color of Wire	Signal Name
18	L	-
19	P	-

ABMIA4802GB

POWER DISTRIBUTION SYSTEM

< WIRING DIAGRAM >

[POWER DISTRIBUTION SYSTEM]

Connector No.	B103
Connector Name	JOINT CONNECTOR-B15
Connector Color	WHITE



Terminal No.	Color of Wire	Signal Name
1	P	-
2	P	-

Connector No.	B102
Connector Name	JOINT CONNECTOR-B14
Connector Color	WHITE



Terminal No.	Color of Wire	Signal Name
1	L	-
2	L	-

Connector No.	B101
Connector Name	WIRE TO WIRE
Connector Color	WHITE

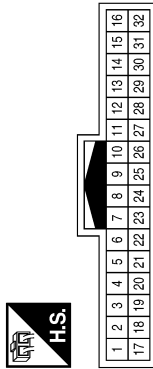

Terminal No.	Color of Wire	Signal Name
17	L	-
18	P	-

Connector No.	B124
Connector Name	WIRE TO WIRE
Connector Color	WHITE

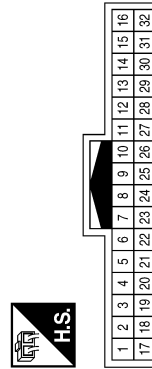

Terminal No.	Color of Wire	Signal Name
18	L	-
19	P	-

ABMIA4803GB

A
B
C
D
E
F
G
H
I
J
K
L
N
O
P

PCS

POWER DISTRIBUTION SYSTEM

< WIRING DIAGRAM >

[POWER DISTRIBUTION SYSTEM]

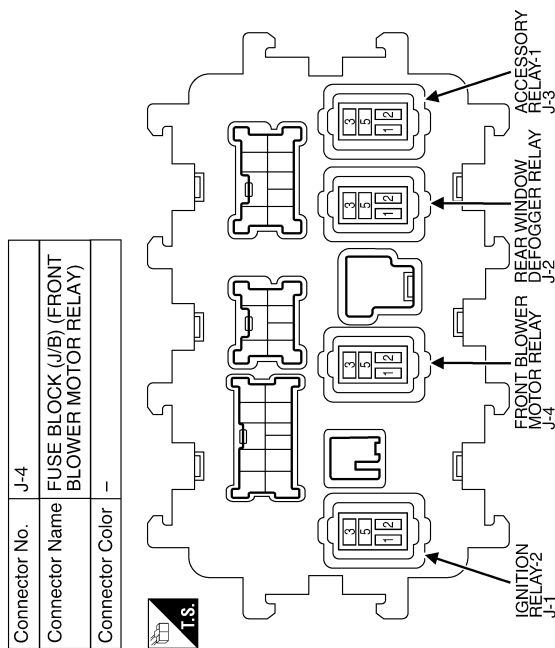
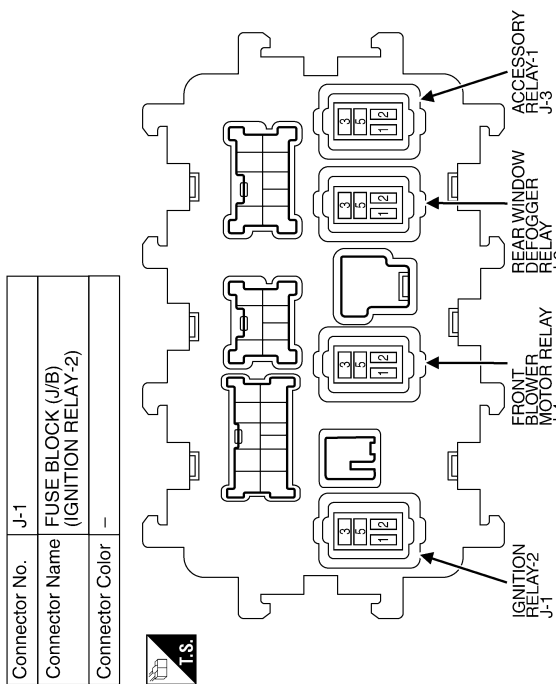
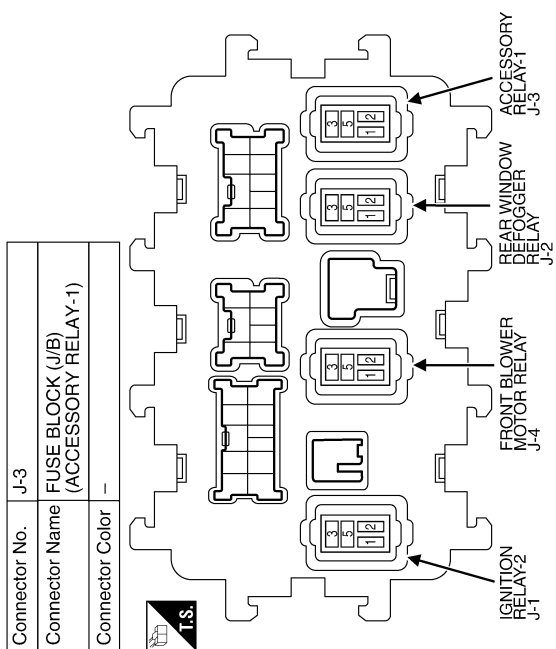

ABMIA4488GB

DIAGNOSIS AND REPAIR WORK FLOW

< BASIC INSPECTION >

[POWER DISTRIBUTION SYSTEM]

BASIC INSPECTION

DIAGNOSIS AND REPAIR WORK FLOW

Work Flow

INFOID:000000009131015

OVERALL SEQUENCE

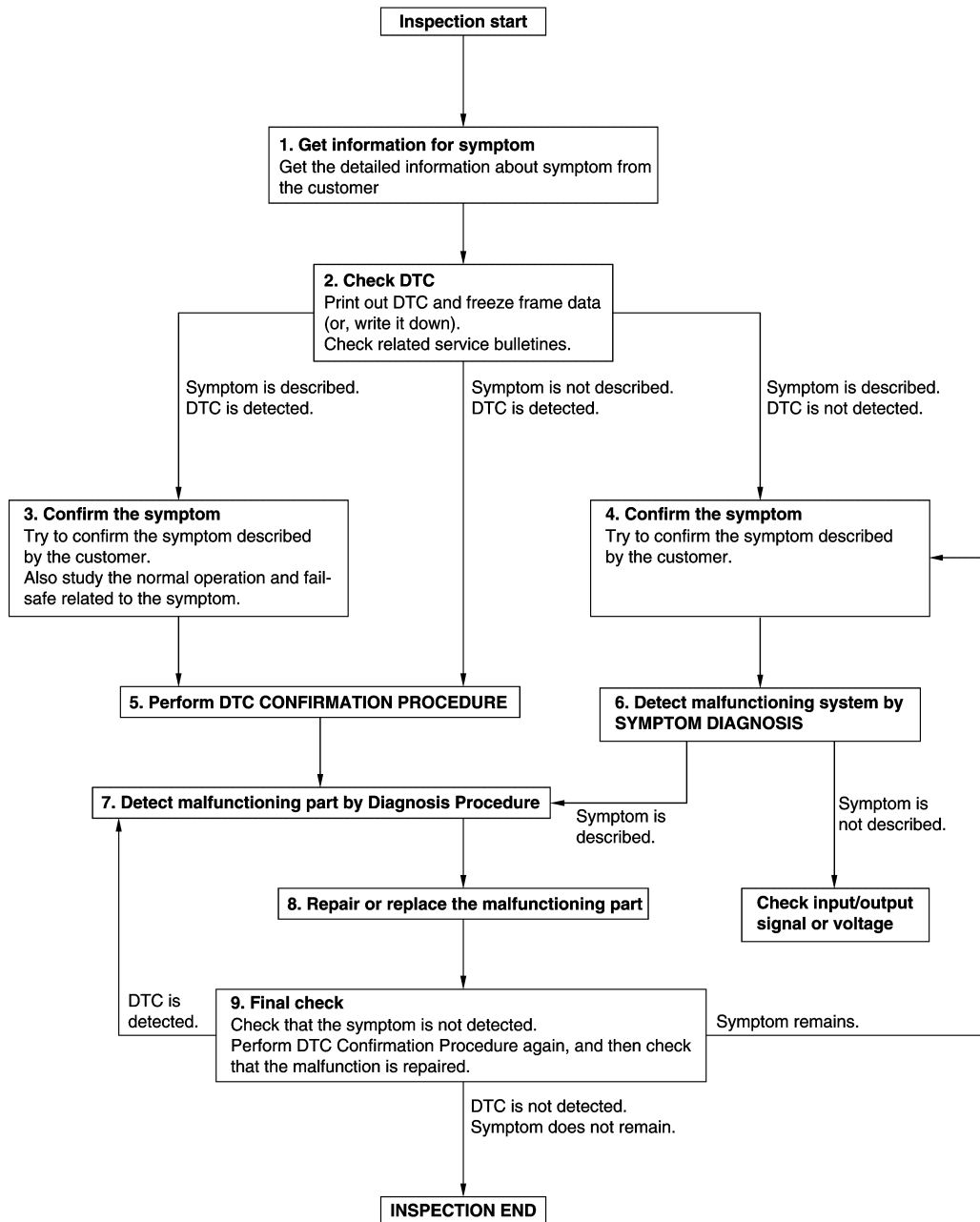

DETAILED FLOW

Revision: August 2013

PCS-55

2014 QX60

JMKIA8652GB

A
B
C
D
E
F
G
H
I
J
K
L
PCS
N
O
P

DIAGNOSIS AND REPAIR WORK FLOW

< BASIC INSPECTION >

[POWER DISTRIBUTION SYSTEM]

1. GET INFORMATION FOR SYMPTOM

1. Get detailed information from the customer about the symptom (the condition and the environment when the incident/malfunction occurs).
2. Check operation condition of the component or system that is malfunctioning.

>> GO TO 2.

2. CHECK DTC

1. Check DTC.
2. Perform the following procedure if DTC is detected.
 - Record DTC and freeze frame data (Print them out using CONSULT).
 - Erase DTC.
 - Study the relationship between the cause detected by DTC and the symptom described by the customer.
3. Check related service bulletins for information.

Are any symptoms described and any DTC detected?

Symptom is described, DTC is detected>>GO TO 3.

Symptom is described, DTC is not detected>>GO TO 4.

Symptom is not described, DTC is detected>>GO TO 5.

3. CONFIRM THE SYMPTOM

Try to confirm the symptom described by the customer.

Also study the normal operation and fail-safe related to the symptom.

Verify relation between the symptom and the condition when the symptom is detected.

>> GO TO 5.

4. CONFIRM THE SYMPTOM

Try to confirm the symptom described by the customer.

Verify relation between the symptom and the condition when the symptom is detected.

NOTE:

Freeze frame data is useful if the DTC is not detected.

>> GO TO 6.

5. PERFORM DTC CONFIRMATION PROCEDURE

Perform DTC CONFIRMATION PROCEDURE for the detected DTC, and then check that DTC is detected again. At this time, always connect CONSULT to the vehicle, and check self diagnostic results in real time.

If two or more DTCs are detected, refer to [BCS-49, "DTC Inspection Priority Chart"](#), and determine trouble diagnosis order.

Is DTC detected?

YES >> GO TO 7.

NO >> Refer to [GI-53, "Intermittent Incident"](#).

6. DETECT MALFUNCTIONING SYSTEM BY SYMPTOM DIAGNOSIS

Detect malfunctioning system according to SYMPTOM DIAGNOSIS based on the confirmed symptom in step 4, and determine the trouble diagnosis order based on possible causes and symptom.

Is the symptom described?

YES >> GO TO 7.

NO >> Monitor input data from related sensors or check voltage of related module terminals using CONSULT.

7. DETECT MALFUNCTIONING PART BY DIAGNOSIS PROCEDURE

Inspect according to Diagnosis Procedure of the system.

Is malfunctioning part detected?

YES >> GO TO 8.

NO >> Refer to [GI-53, "Intermittent Incident"](#).

DIAGNOSIS AND REPAIR WORK FLOW

< BASIC INSPECTION >

[POWER DISTRIBUTION SYSTEM]

8. REPAIR OR REPLACE THE MALFUNCTIONING PART

1. Repair or replace the malfunctioning part.
2. Reconnect parts or connectors disconnected during Diagnosis Procedure again after repair and replacement.
3. Check DTC. If DTC is detected, erase it.

>> GO TO 9.

9. FINAL CHECK

When DTC is detected in step 2, perform DTC CONFIRMATION PROCEDURE again, and then check that the malfunction is repaired securely.

When symptom is described by the customer, refer to confirmed symptom in step 3 or 4, and check that the symptom is not detected.

Is DTC detected and does symptom remain?

YES-1 >> DTC is detected: GO TO 7.

YES-2 >> Symptom remains: GO TO 4.

NO >> Inspection End.

A
B
C
D
E
F
G
H
I
J
K
L

PCS

N
O
P

U1000 CAN COMM CIRCUIT

< DTC/CIRCUIT DIAGNOSIS >

[POWER DISTRIBUTION SYSTEM]

DTC/CIRCUIT DIAGNOSIS

U1000 CAN COMM CIRCUIT

Description

INFOID:000000009131016

Refer to [LAN-17, "CAN COMMUNICATION SYSTEM : System Description"](#).

DTC Logic

INFOID:000000009131017

DTC DETECTION LOGIC

NOTE:

U1000 can be set if a module harness was disconnected and reconnected, perhaps during a repair. Confirm that there are actual CAN diagnostic symptoms and a present DTC by performing the Self Diagnostic Result procedure.

CONSULT Display	DTC Detection Condition	Possible cause
CAN COMM CIRCUIT [U1000]	When any listed module cannot communicate with CAN communication signal continuously for 2 seconds or more with ignition switch ON	In CAN communication system, any item (or items) of the following listed below is malfunctioning. <ul style="list-style-type: none">• Transmission• Receiving (ECM)• Receiving (VDC/TCS/ABS)• Receiving (METER/M&A)• Receiving (TCM)• Receiving (IPDM E/R)

Diagnosis Procedure

INFOID:000000009131018

1. PERFORM SELF DIAGNOSTIC

1. Turn ignition switch ON and wait for 2 second or more.
2. Check "SELF- DIAG RESULTS".

Is "CAN COMM CIRCUIT" displayed?

- YES >> Perform CAN Diagnosis as described in DIAGNOSIS section of CONSULT Operation Manual.
NO >> Refer to [GI-53, "Intermittent Incident"](#).

U1010 CONTROL UNIT (CAN)

< DTC/CIRCUIT DIAGNOSIS >

[POWER DISTRIBUTION SYSTEM]

U1010 CONTROL UNIT (CAN)

DTC Logic

INFOID:000000009131019

DTC DETECTION LOGIC

CONSULT Display	DTC Detection Condition	Possible Cause
CAN COMM CIRCUIT [U1010]	BCM detected internal CAN communication circuit malfunction.	BCM

Diagnosis Procedure

INFOID:000000009131020

1. REPLACE BCM

When DTC U1010 is detected, replace BCM.

>> Replace BCM. Refer to [BCS-79. "Removal and Installation"](#).

A
B
C
D
E
F
G
H
I
J
K
L

PCS

N
O
P

B260A IGNITION RELAY

< DTC/CIRCUIT DIAGNOSIS >

[POWER DISTRIBUTION SYSTEM]

B260A IGNITION RELAY

DTC Logic

INFOID:000000009131021

DTC DETECTION LOGIC

NOTE:

- If DTC B260A is displayed with DTC U1000, first perform the trouble diagnosis for DTC U1000. Refer to [PCS-58, "DTC Logic"](#).
- If DTC B260A is displayed with DTC U1010, first perform the trouble diagnosis for DTC U1010. Refer to [PCS-59, "DTC Logic"](#).
- If DTC B260A is displayed with DTC B261A, first perform the trouble diagnosis for DTC B261A. Refer to [PCS-70, "DTC Logic"](#).

CONSULT Display	DTC Detection Condition	Possible Cause
IGNITION RELAY [B260A]	BCM detects a difference of signal for 2 seconds or more between the following information: <ul style="list-style-type: none">• Ignition relay-1 operation request.• Ignition relay-1 feedback from IPDM E/R (CAN).	<ul style="list-style-type: none">• Harness or connectors• IPDM E/R• BCM

DTC CONFIRMATION PROCEDURE

1. PERFORM SELF DIAGNOSTIC RESULT

1. Turn ignition switch ON under the following conditions, and wait for at least 2 seconds.
 - CVT selector lever is in the P (park) or N (neutral) position.
 - Release the brake pedal.
2. Perform self diagnostic result.

Is DTC B260A detected?

- YES >> Refer to [PCS-60, "Diagnosis Procedure"](#).
NO >> Inspection End.

Diagnosis Procedure

INFOID:000000009131022

Regarding Wiring Diagram information, refer to [PCS-44, "Wiring Diagram"](#).

1. CHECK SELF DIAGNOSTIC RESULT FOR IPDM E/R

Perform self diagnostic result for IPDM E/R.

Are any DTCs detected?

- YES >> Refer to [PCS-20, "DTC Index"](#).
NO >> GO TO 2

2. CHECK IGNITION RELAY-1 POWER SUPPLY (IPDM E/R)

Check voltage between IPDM E/R connector E119 terminal 43 and ground.

IPDM E/R		Ground	Condition	Voltage (Approx.)
Connector	Terminal			
E119	43	—	Ignition: OFF	0V
			Ignition: ON	Battery voltage

Is the inspection result normal?

- YES >> Replace IPDM E/R. Refer to [PCS-32, "Removal and Installation"](#).
NO >> GO TO 3.

3. CHECK IGNITION RELAY-1 POWER SUPPLY (BCM)

Check voltage between BCM connector M19 terminal 70 and ground.

B260A IGNITION RELAY

< DTC/CIRCUIT DIAGNOSIS >

[POWER DISTRIBUTION SYSTEM]

BCM		Ground	Condition	Voltage (Approx.)
Connector	Terminal			
M19	70	—	Ignition: OFF	0V
			Ignition: ON	Battery voltage

Is the inspection result normal?

YES >> Refer to [GI-53, "Intermittent Incident"](#).

NO >> Replace BCM. Refer to [BCS-79, "Removal and Installation"](#).

A
B
C
D
E
F
G
H
I
J
K
L
N
O
P

PCS

B2614 ACC RELAY CIRCUIT

< DTC/CIRCUIT DIAGNOSIS >

[POWER DISTRIBUTION SYSTEM]

B2614 ACC RELAY CIRCUIT

DTC Logic

INFOID:000000009131023

DTC DETECTION LOGIC

CONSULT Display	DTC detecting condition	Possible cause
ACC RELAY CIRCUIT [B2614]	An immediate operation of accessory relay-1 and accessory relay-2 is requested by BCM, but there is no response for more than 1 second.	<ul style="list-style-type: none">• Harness or connectors• Accessory relay-1• Accessory relay-2• Fuse block J/B• BCM

DTC CONFIRMATION PROCEDURE

1. PERFORM SELF DIAGNOSTIC RESULT

1. Turn the power supply position to ACC under the following conditions, and wait for at least 1 second.
 - CVT selector lever is in the P (park) or N (neutral) position.
 - Release the brake pedal.
2. Perform self diagnostic result.

Is DTC B2614 detected?

- YES >> Refer to [PCS-62. "Diagnosis Procedure"](#).
NO >> Inspection End.

Diagnosis Procedure

INFOID:000000009131024

Regarding Wiring Diagram information, refer to [PCS-44. "Wiring Diagram"](#).

1. CHECK ACCESSORY RELAY-1 AND ACCESSORY RELAY-2 POWER SUPPLY CIRCUIT

1. Turn ignition switch OFF.
2. Disconnect accessory relay-1 and accessory relay-2.
3. Disconnect BCM connector M80.
4. Check continuity between accessory relay-1 connector J-3 terminal 2 and BCM connector M80 terminal 113.

Accessory relay-1		BCM		Continuity
Connector	Terminal	Connector	Terminal	
J-3	2	M80	113	Yes

5. Check continuity between accessory relay-2 connector E22 terminal 1 and BCM connector M80 terminal 113.

Accessory relay-2		BCM		Continuity
Connector	Terminal	Connector	Terminal	
E22	1	M80	113	Yes

6. Check continuity between BCM connector M80 terminal 113 and ground.

BCM		Ground	Continuity
Connector	Terminal		
M80	113	—	No

Is the inspection result normal?

- YES >> GO TO 2.
NO >> Repair or replace harness or connectors.

B2614 ACC RELAY CIRCUIT

< DTC/CIRCUIT DIAGNOSIS >

[POWER DISTRIBUTION SYSTEM]

2. CHECK ACCESSORY RELAY-1 AND ACCESSORY RELAY-2 GROUND CIRCUIT

1. Turn ignition switch OFF.
2. Check continuity between accessory relay-1 connector J-3 terminal 1 and ground.

Accessory relay-1		Ground	Continuity
Connector	Terminal		
J-3	1	—	Yes

3. Check continuity between accessory relay-2 connector E22 terminal 2 and ground.

Accessory relay-2		Ground	Continuity
Connector	Terminal		
E22	2	—	Yes

Is the inspection result normal?

YES >> GO TO 3.

NO >> Repair or replace harness or connectors.

3. CHECK ACCESSORY RELAYS

Perform the relay component inspection. Refer to [PCS-63, "Component Inspection \(Relay\)"](#).

Is the inspection result normal?

YES >> GO TO 4.

NO >> Replace relay.

4. CHECK ACCESSORY RELAY-1 AND ACCESSORY RELAY-2 POWER SUPPLY (BCM)

Check voltage between BCM connector M80 terminal 113 and ground.

BCM		Ground	Condition	Voltage (Approx.)
Connector	Terminal			
M80	113	—	Ignition: OFF	0V
			Ignition: ACC	Battery voltage

Is the inspection result normal?

YES >> Refer to [GI-53, "Intermittent Incident"](#).

NO >> Replace BCM. Refer to [BCS-79, "Removal and Installation"](#).

Component Inspection (Relay)

INFOID:000000009131025

1. CHECK RELAY

1. Remove relay.
2. Check the continuity between relay terminals under the following conditions.

Relay terminals	Condition	Continuity
3 and 5	Battery voltage applied to terminal 1 and ground to terminal 2.	Yes
	Voltage and ground removed.	No

Is the inspection result normal?

YES >> Inspection End.

NO >> Replace relay.

A
B
C
D
E
F
G
H
I
J
K
L
N
O
P

PCS

B2615 BLOWER RELAY CIRCUIT

< DTC/CIRCUIT DIAGNOSIS >

[POWER DISTRIBUTION SYSTEM]

B2615 BLOWER RELAY CIRCUIT

DTC Logic

INFOID:000000009131026

DTC DETECTION LOGIC

CONSULT Display	DTC Detection Condition	Possible Cause
BLOWER RELAY CIRCUIT [B2615]	An immediate operation of front blower motor relay is requested by BCM, but there is no response for more than 1 second.	<ul style="list-style-type: none">• Harness or connectors.• Front blower motor relay.• Fuse block J/B.• BCM.

DTC CONFIRMATION PROCEDURE

1. PERFORM SELF DIAGNOSTIC RESULT

1. Turn ignition switch ON under the following conditions, and wait for at least 1 second.
 - CVT selector lever is in the P (park) or N (neutral) position.
 - Release brake pedal.
2. Perform self diagnostic result.

Is DTC B2615 detected?

- YES >> Refer to [PCS-64, "Diagnosis Procedure"](#).
NO >> Inspection End.

Diagnosis Procedure

INFOID:000000009131027

Regarding Wiring Diagram information, refer to [PCS-44, "Wiring Diagram"](#).

1. CHECK FRONT BLOWER MOTOR RELAY POWER SUPPLY CIRCUIT

1. Turn ignition switch OFF.
2. Disconnect front blower motor relay.
3. Disconnect BCM connector M19.
4. Check continuity between front blower motor relay connector J-4 terminal 2 and BCM connector M19 terminal 66.

Front blower motor relay		BCM		Continuity
Connector	Terminal	Connector	Terminal	
J-4	2	M19	66	Yes

5. Check continuity between front blower motor relay connector J-4 terminal 2 and ground.

Front blower motor relay		Ground	Continuity
Connector	Terminal		
J-4	2	—	No

Is the inspection result normal?

- YES >> GO TO 2.
NO >> Repair or replace harness or connectors.

2. CHECK FRONT BLOWER MOTOR RELAY GROUND CIRCUIT

1. Turn ignition switch OFF.
2. Check continuity between front blower motor relay connector J-4 terminal 1 and ground.

B2615 BLOWER RELAY CIRCUIT

< DTC/CIRCUIT DIAGNOSIS >

[POWER DISTRIBUTION SYSTEM]

Front blower motor relay		Ground	Continuity
Connector	Terminal		
J-4	1	—	Yes

Is the inspection result normal?

- YES >> GO TO 3.
- NO >> Repair or replace harness or connectors.

3. CHECK FRONT BLOWER MOTOR RELAY

Perform the relay component inspection. Refer to [PCS-65, "Component Inspection \(Relay\)"](#).

Is the inspection result normal?

- YES >> GO TO 4.
- NO >> Replace front blower motor relay.

4. CHECK FRONT BLOWER MOTOR RELAY POWER SUPPLY (BCM)

Check voltage between BCM connector M19 terminal 66 and ground.

BCM		Ground	Condition	Voltage (Approx.)
Connector	Terminal			
M19	66	—	Ignition: OFF	0V
			Ignition: ON	Battery voltage

Is the inspection result normal?

- YES >> Refer to [GI-53, "Intermittent Incident"](#).
- NO >> Replace BCM. Refer to [BCS-79, "Removal and Installation"](#).

Component Inspection (Relay)

INFOID:000000009131028

1. CHECK RELAY

1. Remove relay.
2. Check the continuity between relay terminals under the following conditions.

Relay terminals	Condition	Continuity
3 and 5	Battery voltage applied to terminal 1 and ground to terminal 2.	Yes
	Voltage and ground removed.	No

Is the inspection result normal?

- YES >> Inspection End.
- NO >> Replace relay.

PCS

B2616 IGNITION RELAY CIRCUIT

< DTC/CIRCUIT DIAGNOSIS >

[POWER DISTRIBUTION SYSTEM]

B2616 IGNITION RELAY CIRCUIT

DTC Logic

INFOID:000000009131029

DTC DETECTION LOGIC

CONSULT Display	DTC Detection Condition	Possible Cause
IGNITION RELAY CIRCUIT [B2616]	An immediate operation of ignition relay-2 is requested by BCM, but there is no response for more than 1 second.	<ul style="list-style-type: none">• Harness or connectors.• Ignition relay-2.• Fuse block J/B.• BCM.

DTC CONFIRMATION PROCEDURE

1. PERFORM SELF DIAGNOSTIC RESULT

1. Turn ignition switch ON under the following conditions, and wait for at least 1 second.
 - CVT selector lever is in the P (park) or N (neutral) position.
 - Release brake pedal
2. Perform self diagnostic result.

Is DTC B2616 detected?

- YES >> Refer to [PCS-66, "Diagnosis Procedure"](#).
NO >> Inspection End.

Diagnosis Procedure

INFOID:000000009131030

Regarding Wiring Diagram information, refer to [PCS-44, "Wiring Diagram"](#).

1. CHECK IGNITION RELAY-2 POWER SUPPLY CIRCUIT

1. Turn ignition switch OFF.
2. Disconnect BCM connector M19.
3. Check continuity between ignition relay-2 connector J-1 terminal 1 and BCM connector M19 terminal 67.

Ignition relay-2		BCM		Continuity
Connector	Terminal	Connector	Terminal	
J-1	1	M19	67	Yes

4. Check continuity between ignition relay-2 connector J-1 terminal 1 and ground.

Ignition relay-2		Ground	Continuity
Connector	Terminal		
J-1	1	—	No

Is the inspection result normal?

- YES >> GO TO 2.
NO >> Repair or replace harness or connectors.

2. CHECK IGNITION RELAY-2 GROUND CIRCUIT

1. Turn ignition switch OFF.
2. Check continuity between ignition relay-2 connector J-1 terminal 2 and ground.

Ignition relay-2		Ground	Continuity
Connector	Terminal		
J-1	2	—	Yes

Is the inspection result normal?

B2616 IGNITION RELAY CIRCUIT

[POWER DISTRIBUTION SYSTEM]

< DTC/CIRCUIT DIAGNOSIS >

- YES >> GO TO 3.
NO >> Repair or replace harness or connectors.

3. CHECK IGNITION RELAY-2

Perform the relay component inspection. Refer to [PCS-67. "Component Inspection \(Relay\)"](#).

Is the inspection result normal?

- YES >> GO TO 4.
NO >> Replace ignition relay-2.

4. CHECK IGNITION RELAY-2 POWER SUPPLY (BCM)

Check voltage between BCM connector M19 terminal 67 and ground.

BCM		Ground	Condition	Voltage (Approx.)
Connector	Terminal			
M19	67	—	Ignition: OFF	0V
			Ignition: ON	Battery voltage

Is the inspection result normal?

- YES >> Refer to [GI-53. "Intermittent Incident"](#).
NO >> Replace BCM. Refer to [BCS-79. "Removal and Installation"](#).

Component Inspection (Relay)

INFOID:000000009131031

1. CHECK RELAY

1. Remove relay.
2. Check the continuity between relay terminals under the following conditions.

Relay terminals	Condition	Continuity
3 and 5	Battery voltage applied to terminal 1 and ground to terminal 2.	Yes
	Voltage and ground removed.	No

Is the inspection result normal?

- YES >> Inspection End.
NO >> Replace relay.

A
B
C
D
E
F
G
H
I
J
K
L
N
O
P

PCS

B2618 BCM

DTC Logic

INFOID:000000009131032

DTC DETECTION LOGIC

NOTE:

- If DTC B2618 is displayed with DTC U1000, first perform the trouble diagnosis for DTC U1000. Refer to [PCS-58, "DTC Logic"](#).
- If DTC B2618 is displayed with DTC U1010, first perform the trouble diagnosis for DTC U1010. Refer to [PCS-59, "DTC Logic"](#).

CONSULT Display	DTC Detection Condition	Possible Cause
BCM [B2618]	An immediate operation of ignition relay-1 is requested by BCM, but there is no response for more than 1 second	• BCM

DTC CONFIRMATION PROCEDURE

1. PERFORM SELF DIAGNOSTIC RESULT

1. Turn ignition switch ON under the following conditions, and wait for at least 1 second.
 - CVT selector lever is in the P (park) or N (neutral) position.
 - Release brake pedal
2. Perform self diagnostic result.

Is DTC B2618 detected?

- YES >> Refer to [PCS-68, "Diagnosis Procedure"](#).
- NO >> Inspection End.

Diagnosis Procedure

INFOID:000000009131033

Regarding Wiring Diagram information, refer to [PCS-44, "Wiring Diagram"](#).

1. CHECK SELF DIAGNOSTIC RESULT FOR IPDM E/R

Perform self diagnostic result for IPDM E/R.

Are any DTCs detected?

- YES >> Refer to [PCS-20, "DTC Index"](#).
- NO >> GO TO 2

2. CHECK IGNITION RELAY-1 POWER SUPPLY (IPDM E/R)

Check voltage between IPDM E/R connector E119 terminal 43 and ground.

IPDM E/R		Ground	Condition	Voltage (Approx.)
Connector	Terminal			
E119	43	—	Ignition: OFF	0V
			Ignition: ON	Battery voltage

Is the inspection result normal?

- YES >> Replace IPDM E/R. Refer to [PCS-32, "Removal and Installation"](#).
- NO >> GO TO 3.

3. CHECK IGNITION RELAY-1 POWER SUPPLY (BCM)

Check voltage between BCM connector M19 terminal 70 and ground.

BCM		Ground	Condition	Voltage (Approx.)
Connector	Terminal			

B2618 BCM

< DTC/CIRCUIT DIAGNOSIS >

[POWER DISTRIBUTION SYSTEM]

M19	70	—	Ignition: OFF	0V
			Ignition: ON	Battery voltage

Is the inspection result normal?

YES >> Refer to [GI-53, "Intermittent Incident"](#).

NO >> Replace BCM. Refer to [BCS-79, "Removal and Installation"](#).

A
B
C
D
E
F
G
H
I
J
K
L
N
O
P

PCS

B261A PUSH-BUTTON IGNITION SWITCH

< DTC/CIRCUIT DIAGNOSIS >

[POWER DISTRIBUTION SYSTEM]

B261A PUSH-BUTTON IGNITION SWITCH

DTC Logic

INFOID:000000009131034

DTC DETECTION LOGIC

CONSULT Display	DTC Detection Condition	Possible Cause
PUSH-BUTTONIGNITION SWITCH [B261A]	BCM detects a difference of signal for 1 second or more between the following information: <ul style="list-style-type: none">• Power supply position by push-button ignition switch.• Power supply position from IPDM E/R (CAN).	<ul style="list-style-type: none">• Harness or connectors• Push-button ignition switch• BCM

DTC CONFIRMATION PROCEDURE

1. PERFORM SELF DIAGNOSTIC RESULT

1. Press the push-button ignition switch under the following conditions, and wait for at least 1 second.
 - CVT selector lever is in the P (park) or N (neutral) position.
 - Release the brake pedal.
2. Perform self diagnostic result.

Is DTC B261A detected?

- YES >> Refer to [PCS-70. "Diagnosis Procedure"](#).
NO >> Inspection End.

Diagnosis Procedure

INFOID:000000009131035

Regarding Wiring Diagram information, refer to [PCS-44. "Wiring Diagram"](#).

1. CHECK PUSH-BUTTON IGNITION SWITCH OUTPUT SIGNAL (PUSH-BUTTON IGNITION SWITCH)

1. Disconnect push-button ignition switch connector.
2. Check voltage between push-button ignition switch connector M17 terminal 8 and ground.

Push-button ignition switch		Ground	Voltage (Approx.)
Connector	Terminal		
M17	8	—	Battery voltage

Is the inspection result normal?

- YES >> GO TO 2.
NO >> GO TO 4.

2. CHECK IGNITION SWITCH OUTPUT SIGNAL (IPDM E/R)

Check voltage between IPDM E/R connector E119 terminal 38 and ground.

IPDM E/R		Ground	Voltage (Approx.)
Connector	Terminal		
E119	38	—	Battery voltage

Is the inspection result normal?

- YES >> GO TO 3.
NO >> Replace IPDM E/R. Refer to [PCS-32. "Removal and Installation"](#).

3. CHECK PUSH-BUTTON IGNITION SWITCH CIRCUIT (IPDM E/R)

1. Turn ignition switch OFF.
2. Disconnect IPDM E/R connector E119 and BCM connector M18.

B261A PUSH-BUTTON IGNITION SWITCH

[POWER DISTRIBUTION SYSTEM]

< DTC/CIRCUIT DIAGNOSIS >

3. Check continuity between IPDM E/R connector E119 terminal 38 and push-button ignition switch connector M17 terminal 8.

IPDM E/R		Push-button ignition switch		Continuity
Connector	Terminal	Connector	Terminal	
E119	38	M17	8	Yes

4. Check continuity between IPDM E/R connector E119 terminal 38 and ground.

IPDM E/R		Ground	Continuity
Connector	Terminal		
E119	38	—	No

Is the inspection result normal?

YES >> Refer to [GI-53, "Intermittent Incident"](#).

NO >> Repair or replace harness or connectors.

4. CHECK IGNITION SWITCH OUTPUT SIGNAL (BCM)

Check voltage between BCM connector M18 terminal 1 and ground.

BCM		Ground	Voltage (Approx.)
Connector	Terminal		
M18	1	—	Battery voltage

Is the inspection result normal?

YES >> GO TO 5.

NO >> Replace BCM. Refer to [BCS-79, "Removal and Installation"](#).

5. CHECK PUSH-BUTTON IGNITION SWITCH CIRCUIT (BCM)

1. Turn ignition switch OFF.
2. Disconnect BCM connector M18 and IPDM E/R connector E119.
3. Check continuity between BCM connector M18 terminal 1 and push-button ignition switch connector M17 terminal 8.

BCM		Push-button ignition switch		Continuity
Connector	Terminal	Connector	Terminal	
M18	1	M17	8	Yes

4. Check continuity between BCM connector M18 terminal 1 and ground.

BCM		Ground	Continuity
Connector	Terminal		
M18	1	—	No

Is the inspection result normal?

YES >> Refer to [GI-53, "Intermittent Incident"](#).

NO >> Repair or replace harness or connectors.

A
B
C
D
E
F
G
H
I
J
K
L
N
O
P

PCS

B26F1 IGNITION RELAY

< DTC/CIRCUIT DIAGNOSIS >

[POWER DISTRIBUTION SYSTEM]

B26F1 IGNITION RELAY

DTC Logic

INFOID:000000009131036

DTC DETECTION LOGIC

CONSULT Display	DTC detecting condition	Possible cause
IGN RELAY OFF [B26F1]	BCM transmits the ignition relay control signal, but does not receive ignition switch ON signal (CAN) from IPDM E/R.	<ul style="list-style-type: none"> • Harness or connectors • BCM • IPDM E/R

DTC CONFIRMATION PROCEDURE

1. PERFORM SELF DIAGNOSTIC RESULT

1. Turn ignition switch ON under the following conditions, and wait for 2 seconds or more.
 - CVT selector lever is in the P (park) or N (neutral) position.
 - Do not depress brake pedal.
2. Perform self diagnostic result.

Is DTC B26F1 detected?

- YES >> Go to [PCS-72, "Diagnosis Procedure"](#).
 NO >> Inspection End.

Diagnosis Procedure

INFOID:000000009131037

Regarding Wiring Diagram information, refer to [PCS-44, "Wiring Diagram"](#).

1. CHECK SELF DIAGNOSTIC RESULT FOR IPDM E/R

1. Perform self diagnostic result for IPDM E/R.
2. Erase DTCs.
3. Turn ignition switch OFF.
4. Turn ignition switch ON.
5. Perform self diagnostic result for IPDM E/R.

Are any DTCs detected?

- YES >> Refer to [PCS-20, "DTC Index"](#).
 NO >> GO TO 2.

2. CHECK IGNITION RELAY-1 CONTROL SIGNAL (IPDM E/R)

Check voltage between BCM connector M19 terminal 70 and ground.

BCM		Ground	Condition	Voltage (Approx.)
Connector	Terminal			
M19	70	—	Ignition: OFF	0V
			Ignition: ON	Battery voltage

Is the inspection result normal?

- YES >> GO TO 3.
 NO >> Replace BCM. Refer to [BCS-79, "Removal and Installation"](#).

3. CHECK IGNITION RELAY-1 CONTROL SIGNAL CIRCUIT

1. Turn ignition switch OFF.
2. Disconnect IPDM E/R connector E119 and BCM connector M19.
3. Check continuity between IPDM E/R connector E119 terminal 43 and BCM connector M19 terminal 70.

B26F1 IGNITION RELAY

< DTC/CIRCUIT DIAGNOSIS >

[POWER DISTRIBUTION SYSTEM]

IPDM E/R		BCM		Continuity
Connector	Terminal	Connector	Terminal	
E119	43	M19	70	Yes

4. Check continuity between IPDM E/R connector E119 terminal 43 and ground.

IPDM E/R		Ground	Continuity
Connector	Terminal		
E119	43	—	No

Is the inspection result normal?

- YES >> Replace IPDM E/R. Refer to [PCS-32. "Removal and Installation"](#).
- NO >> Repair or replace harness or connectors.

A
B
C
D
E
F
G
H
I
J
K
L

PCS

N
O
P

B26F2 IGNITION RELAY

< DTC/CIRCUIT DIAGNOSIS >

[POWER DISTRIBUTION SYSTEM]

B26F2 IGNITION RELAY

DTC Logic

INFOID:000000009131038

DTC DETECTION LOGIC

CONSULT Display	DTC detecting condition	Possible cause
IGN RELAY ON [B26F2]	BCM transmits the ignition relay control signal, but does not receive ignition switch ON signal (CAN) from IPDM E/R.	<ul style="list-style-type: none">• Harness or connectors• BCM• IPDM E/R

DTC CONFIRMATION PROCEDURE

1. PERFORM SELF DIAGNOSTIC RESULT

1. Turn ignition switch ON under the following conditions, and wait for 2 seconds or more.
 - CVT selector lever is in the P (park) or N (neutral) position.
 - Do not depress brake pedal.
2. Perform self diagnostic result.

Is DTC B26F2 detected?

- YES >> Go to [PCS-74. "Diagnosis Procedure"](#).
NO >> Inspection End.

Diagnosis Procedure

INFOID:000000009131039

Regarding Wiring Diagram information, refer to [PCS-44. "Wiring Diagram"](#).

1. CHECK SELF DIAGNOSTIC RESULT FOR IPDM E/R

1. Perform self diagnostic result for IPDM E/R.
2. Erase DTCs.
3. Turn ignition switch OFF.
4. Turn ignition switch ON.
5. Perform self diagnostic result for IPDM E/R.

Are any DTCs detected?

- YES >> Refer to [PCS-20. "DTC Index"](#).
NO >> GO TO 2.

2. CHECK IGNITION RELAY-1 CONTROL SIGNAL (IPDM E/R)

1. Turn ignition switch OFF.
2. Disconnect IPDM E/R connector E119.
3. Check voltage between IPDM E/R connector E119 terminal 43 and ground.

IPDM E/R		Ground	Condition	Voltage (Approx.)
Connector	Terminal			
E119	43	—	Ignition: OFF	0V

Is the inspection result normal?

- YES >> Replace IPDM E/R. Refer to [PCS-32. "Removal and Installation"](#).
NO >> GO TO 3.

3. CHECK IGNITION RELAY-1 CONTROL SIGNAL CIRCUIT

1. Disconnect BCM connector M19.
2. Check voltage between IPDM E/R connector E119 terminal 43 and ground.

B26F2 IGNITION RELAY

< DTC/CIRCUIT DIAGNOSIS >

[POWER DISTRIBUTION SYSTEM]

IPDM E/R		Ground	Condition	Voltage (Approx.)
Connector	Terminal			
E119	43	—	Ignition: OFF	0V

Is the inspection result normal?

YES >> Replace BCM. Refer to [BCS-79. "Removal and Installation"](#).

NO >> Repair or replace harness or connectors.

A
B
C
D
E
F
G
H
I
J
K
L
N
O
P

PCS

B26F6 BCM

DTC Logic

INFOID:000000009131040

DTC DETECTION LOGIC

NOTE:

- If DTC B26F6 is displayed with DTC U1000, first perform the trouble diagnosis for DTC U1000. Refer to [PCS-58, "DTC Logic"](#).
- If DTC B26F6 is displayed with DTC U1010, first perform the trouble diagnosis for DTC U1010. Refer to [PCS-59, "DTC Logic"](#).

CONSULT Display	DTC Detection Condition	Possible Cause
BCM [B26F6]	Ignition relay ON signal is not transmitted from IPDM E/R (CAN) when BCM turns ignition relay ON.	BCM

DTC CONFIRMATION PROCEDURE

1. PERFORM SELF DIAGNOSTIC RESULT

1. Turn ignition switch ON under the following conditions, and wait for 2 seconds or more.
 - CVT selector lever is in the P (park) or N (neutral) position.
 - Do not depress brake pedal.
2. Perform self diagnostic result.

Is DTC B26F6 detected?

- YES >> Go to [PCS-76, "Diagnosis Procedure"](#).
- NO >> Inspection End.

Diagnosis Procedure

INFOID:000000009131041

Regarding Wiring Diagram information, refer to [PCS-44, "Wiring Diagram"](#).

1. CHECK SELF DIAGNOSTIC RESULT FOR IPDM E/R

Perform self diagnostic result for IPDM E/R.

Are any DTCs detected?

- YES >> Refer to [PCS-20, "DTC Index"](#).
- NO >> GO TO 2

2. CHECK IGNITION RELAY-1 POWER SUPPLY (IPDM E/R)

Check voltage between IPDM E/R connector E119 terminal 43 and ground.

IPDM E/R		Ground	Condition	Voltage (Approx.)
Connector	Terminal			
E119	43	—	Ignition: OFF	0V
			Ignition: ON	Battery voltage

Is the inspection result normal?

- YES >> Replace IPDM E/R. Refer to [PCS-32, "Removal and Installation"](#).
- NO >> GO TO 3.

3. CHECK IGNITION RELAY-1 POWER SUPPLY (BCM)

Check voltage between BCM connector M19 terminal 70 and ground.

BCM		Ground	Condition	Voltage (Approx.)
Connector	Terminal			

B26F6 BCM

< DTC/CIRCUIT DIAGNOSIS >

[POWER DISTRIBUTION SYSTEM]

M19	70	—	Ignition: OFF	0V
			Ignition: ON	Battery voltage

Is the inspection result normal?

YES >> Refer to [GI-53, "Intermittent Incident"](#).

NO >> Replace BCM. Refer to [BCS-79, "Removal and Installation"](#).

A
B
C
D
E
F
G
H
I
J
K
L
N
O
P

PCS

PUSH-BUTTON IGNITION SWITCH

< DTC/CIRCUIT DIAGNOSIS >

[POWER DISTRIBUTION SYSTEM]

PUSH-BUTTON IGNITION SWITCH

Component Function Check

INFOID:000000009131042

1. CHECK FUNCTION

1. Select "PUSH SW" in "Data Monitor" of BCM with CONSULT.
2. Check the push-button ignition switch signal under the following conditions.

Test item	Condition	Status
PUSH SW	Push-button ignition switch is pressed	On
	Push-button ignition switch is not pressed	Off

Is the indication normal?

- YES >> Inspection End.
NO >> Go to [PCS-78, "Diagnosis Procedure"](#).

Diagnosis Procedure

INFOID:000000009131043

Regarding Wiring Diagram information, refer to [PCS-44, "Wiring Diagram"](#).

1. CHECK PUSH-BUTTON IGNITION SWITCH OUTPUT SIGNAL (PUSH-BUTTON IGNITION SWITCH)

1. Turn ignition switch OFF.
2. Disconnect push-button ignition switch connector and IPDM E/R connector E119.
3. Check voltage between push-button ignition switch connector M17 terminal 8 and ground.

Push-button ignition switch		Ground	Voltage (Approx.)
Connector	Terminal		
M17	8	—	Battery voltage

Is the inspection result normal?

- YES >> GO TO 3.
NO >> GO TO 2.

2. CHECK PUSH-BUTTON IGNITION SWITCH CIRCUIT (BCM)

1. Disconnect BCM connector M18.
2. Check continuity between BCM connector M18 terminal 1 and push-button ignition switch connector M17 terminal 8.

BCM		Push-button ignition switch		Continuity
Connector	Terminal	Connector	Terminal	
M18	1	M17	8	Yes

3. Check continuity between BCM connector M18 terminal 1 and ground.

BCM		Ground	Continuity
Connector	Terminal		
M18	1	—	No

Is the inspection result normal?

- YES >> Replace BCM. Refer to [BCS-79, "Removal and Installation"](#).
NO >> Repair or replace harness or connectors.

3. CHECK IGNITION SWITCH OUTPUT SIGNAL (IPDM E/R)

Check voltage between IPDM E/R connector E119 terminal 38 and ground.

PUSH-BUTTON IGNITION SWITCH

< DTC/CIRCUIT DIAGNOSIS >

[POWER DISTRIBUTION SYSTEM]

IPDM E/R		Ground	Voltage (Approx.)
Connector	Terminal		
E119	38	—	Battery voltage

Is the inspection result normal?

- YES >> GO TO 5.
- NO >> GO TO 4.

4. CHECK PUSH-BUTTON IGNITION SWITCH CIRCUIT (IPDM E/R)

1. Disconnect BCM connector M18.
2. Check continuity between IPDM E/R connector E119 terminal 38 and push-button ignition switch connector M17 terminal 8.

IPDM E/R		Push-button ignition switch		Continuity
Connector	Terminal	Connector	Terminal	
E119	38	M17	8	Yes

3. Check continuity between IPDM E/R connector E119 terminal 38 and ground.

IPDM E/R		Ground	Continuity
Connector	Terminal		
E119	38	—	No

Is the inspection result normal?

- YES >> Replace IPDM E/R. Refer to [PCS-32, "Removal and Installation"](#).
- NO >> Repair or replace harness or connectors.

5. CHECK PUSH-BUTTON IGNITION SWITCH GROUND CIRCUIT

Check continuity between push-button ignition switch connector M17 terminal 4 and ground.

Push-button ignition switch		Ground	Continuity
Connector	Terminal		
M17	4	—	Yes

Is the inspection result normal?

- YES >> GO TO 6.
- NO >> Repair or replace harness or connectors.

6. CHECK PUSH-BUTTON IGNITION SWITCH

Refer to [PCS-79, "Component Inspection"](#).

Is the inspection result normal?

- YES >> Refer to [GI-53, "Intermittent Incident"](#).
- NO >> Replace push-button ignition switch.

Component Inspection

INFOID:000000009131044

1. CHECK PUSH-BUTTON IGNITION SWITCH

1. Turn ignition switch OFF.
2. Disconnect push-button ignition switch connector.
3. Check continuity between push-button ignition switch terminals.

Push-button ignition switch terminals	Condition	Continuity
4 – 8	Pressed	Yes
	Not pressed	No

Is the inspection result normal?

A
B
C
D
E
F
G
H
I
J
K
L
N
O
P

PCS

PUSH-BUTTON IGNITION SWITCH

< DTC/CIRCUIT DIAGNOSIS >

[POWER DISTRIBUTION SYSTEM]

- YES >> Inspection End.
- NO >> Replace push-button ignition switch.

POWER SUPPLY AND GROUND CIRCUIT

< DTC/CIRCUIT DIAGNOSIS >

[POWER DISTRIBUTION SYSTEM]

POWER SUPPLY AND GROUND CIRCUIT

BCM

BCM : Diagnosis Procedure

INFOID:000000009725724

Regarding Wiring Diagram information, refer to [BCS-54. "Wiring Diagram"](#).

1. CHECK FUSE AND FUSIBLE LINK

Check that the following fuse and fusible link are not blown.

Terminal No.	Signal name	Fuse and fusible link No.
139	Fusible link battery power	O (40A)
131	BCM battery fuse	1 (10A)

Is the fuse or fusible link blown?

- YES >> Replace the blown fuse or fusible link after repairing the affected circuit.
NO >> GO TO 2

2. CHECK POWER SUPPLY CIRCUIT

1. Disconnect BCM connector M81.
2. Check voltage between BCM connector M81 terminals 131, 139 and ground.

BCM		Ground	Voltage (Approx.)
Connector	Terminal		
M81	131	—	Battery voltage
	139		

Is the inspection result normal?

- YES >> GO TO 3
NO >> Repair or replace harness or connectors.

3. CHECK GROUND CIRCUIT

Check continuity between BCM connector M81 terminals 134, 143 and ground.

BCM		Ground	Continuity
Connector	Terminal		
M81	134	—	Yes
	143		

Is the inspection result normal?

- YES >> Inspection End.
NO >> Repair or replace harness or connectors.

IPDM E/R (INTELLIGENT POWER DISTRIBUTION MODULE ENGINE ROOM)

IPDM E/R (INTELLIGENT POWER DISTRIBUTION MODULE ENGINE ROOM) : Diagnosis Procedure

INFOID:000000009725725

Regarding Wiring Diagram information, refer to [PCS-21. "Wiring Diagram"](#).

1. CHECK FUSIBLE LINKS

POWER SUPPLY AND GROUND CIRCUIT

< DTC/CIRCUIT DIAGNOSIS >

[POWER DISTRIBUTION SYSTEM]

Check that the following fusible links are not blown.

Terminal No.	Signal name	Fusible link No.
1	Fusible link main	E (80A)
2	Fusible link IPDM E/R	A (250A), C (80A)
3	Fusible link ignition switch	A (250A), B (100A), K (40A)

Is the fusible link blown?

YES >> Replace the blown fusible link after repairing the affected circuit.

NO >> GO TO 2

2. CHECK POWER SUPPLY CIRCUIT

1. Disconnect IPDM E/R connectors E118 and E120.
2. Check voltage between IPDM E/R connectors and ground.

IPDM E/R		Ground	Voltage (Approx.)
Connector	Terminal		
E118	1	—	Battery voltage
	2		
E120	3		

Is the inspection result normal?

YES >> GO TO 3

NO >> Repair or replace harness or connectors.

3. CHECK GROUND CIRCUIT

1. Disconnect IPDM E/R connectors E119 and E121.
2. Check continuity between IPDM E/R connectors and ground.

IPDM E/R		Ground	Continuity
Connector	Terminal		
E121	7	—	Yes
E119	41		

Is the inspection result normal?

YES >> Inspection End.

NO >> Repair or replace harness or connectors.

PUSH-BUTTON IGNITION SWITCH DOES NOT OPERATE

< SYMPTOM DIAGNOSIS >

[POWER DISTRIBUTION SYSTEM]

SYMPTOM DIAGNOSIS

PUSH-BUTTON IGNITION SWITCH DOES NOT OPERATE

Description

INFOID:000000009131047

Check that vehicle is under the condition shown in “Conditions of vehicle” before starting diagnosis, and check each symptom.

NOTE:

The engine start function, door lock function, power distribution system, and NATS-IVIS in the Intelligent Key system are closely related to each other regarding control. The vehicle security function can operate only when the door lock and power distribution system are operating normally.

Conditions of Vehicle (Operating Conditions)

- “ENGINE START BY I-KEY” in “WORK SUPPORT” is ON when setting on CONSULT.
- One or more of Intelligent Keys with registered Intelligent Key ID is in the vehicle.

Diagnosis Procedure

INFOID:000000009131048

1.PERFORM WORK SUPPORT

Perform “INSIDE ANT DIAGNOSIS” on Work Support of “INTELLIGENT KEY”.

Refer to [BCS-20, "INTELLIGENT KEY : CONSULT Function \(BCM - INTELLIGENT KEY\)"](#).

>> GO TO 2.

2.PERFORM SELF-DIAGNOSTIC RESULT

Perform self diagnostic result.

Are any DTCs detected?

YES >> Refer to [BCS-51, "DTC Index"](#).

NO >> GO TO 3.

3.CHECK PUSH-BUTTON IGNITION SWITCH

Check push-button ignition switch.

Refer to [PCS-78, "Component Function Check"](#).

Is the operation normal?

YES >> GO TO 4.

NO >> Repair or replace malfunctioning parts.

4.CONFIRM THE OPERATION

Confirm the operation again.

Is the inspection normal?

YES >> Check intermittent incident. Refer to [GI-53, "Intermittent Incident"](#).

NO >> GO TO 1.

A
B
C
D
E
F
G
H
I
J
K
L
N
O
P

PCS

BCM (BODY CONTROL MODULE)

< REMOVAL AND INSTALLATION >

[POWER DISTRIBUTION SYSTEM]

REMOVAL AND INSTALLATION

BCM (BODY CONTROL MODULE)

Removal and Installation

INFOID:000000009131049

For removal and installation of the BCM (Body Control Module), refer to [BCS-79, "Removal and Installation"](#).

PUSH BUTTON IGNITION SWITCH

< REMOVAL AND INSTALLATION >

[POWER DISTRIBUTION SYSTEM]

PUSH BUTTON IGNITION SWITCH

Exploded View

INFOID:000000009131050

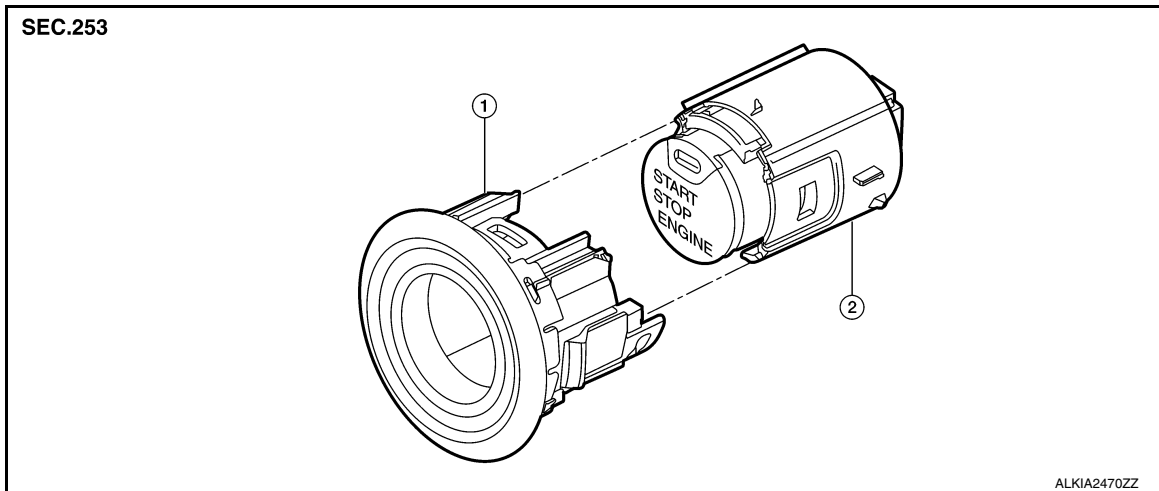

1. NATS antenna amp.
2. Push-button ignition switch

Removal and Installation

INFOID:000000009131051

REMOVAL

1. Remove the instrument lower panel LH. Refer to [IP-25. "Removal and Installation"](#).
2. Release the pawl (➡) on each side of NATS antenna amp (1) and remove from the instrument pad (LH) (2).

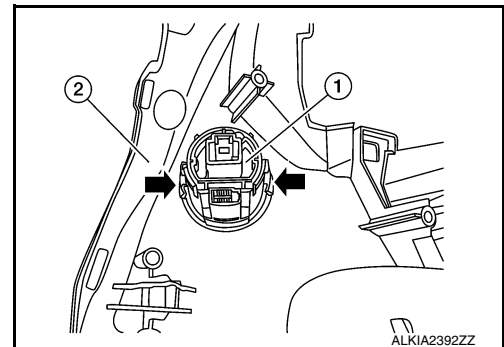

3. Release the pawl on each side and remove the push-button ignition switch from the NATS antenna amp.

INSTALLATION

Installation is in the reverse order of removal.

A
B
C
D
E
F
G
H
I
J
K
L
N
O
P

PCS