

A
B
C
D

WT

SECTION

ROAD WHEELS & TIRES

CONTENTS

WT

PRECAUTION	BCM	F
	List of ECU Reference	
PRECAUTIONS	WIRING DIAGRAM	G
Precaution for Supplemental Restraint System (SRS) "AIR BAG" and "SEAT BELT PRE-TEN- SIONER"	TIRE PRESSURE MONITORING SYSTEM	H
Service Notice and Precautions for TPMS	Wiring Diagram	
Precautions for Road Wheel	BASIC INSPECTION	I
PREPARATION	DIAGNOSIS AND REPAIR WORK FLOW	J
	Work Flow	
PREPARATION	ID REGISTRATION PROCEDURE	K
Special Service Tool	Description	
Commercial Service Tool	Work Procedure	L
SYSTEM DESCRIPTION	DTC/CIRCUIT DIAGNOSIS	M
COMPONENT PARTS	C1704, C1705, C1706, C1707 LOW TIRE PRESSURE	N
Component Parts Location	DTC Logic	
Component Description	Diagnosis Procedure	O
BCM	C1708, C1709, C1710, C1711 TRANSMITTER (NO DATA)	P
Transmitter	DTC Logic	
Remote Keyless Entry Receiver	Diagnosis Procedure	
Outside Key Antennas	C1712, C1713, C1714, C1715 TRANSMITTER (CHECKSUM)	
Combination Meter	DTC Logic	
SYSTEM	Diagnosis Procedure	
System Diagram	C1716, C1717, C1718, C1719 TRANSMITTER (PRESSURE DATA)	
System Description	DTC Logic	
Tire Inflation Indicator Function	Diagnosis Procedure	
DIAGNOSIS SYSTEM (BCM)	C1720, C1721, C1722, C1723 TRANSMITTER	
COMMON ITEM	DTC Logic	
COMMON ITEM : CONSULT Function (BCM - COMMON ITEM)		
AIR PRESSURE MONITOR		
AIR PRESSURE MONITOR : CONSULT Function (BCM-AIR PRESSURE MONITOR)		
ECU DIAGNOSIS INFORMATION		

Diagnosis Procedure	36	Low Tire Pressure Warning Lamp Stays On When Ignition Switch Is Turned On	49
C1724, C1725, C1726, C1727 TRANSMITTER (BATT VOLT)	38	TIRE INFLATION INDICATOR DOES NOT ACTIVATE	50
DTC Logic	38	Description	50
Diagnosis Procedure	38	Diagnosis Procedure	50
C1729 VEHICLE SPEED SIGNAL	40	NOISE, VIBRATION AND HARSHNESS (NVH) TROUBLESHOOTING	51
DTC Logic	40	NVH Troubleshooting Chart	51
Diagnosis Procedure	40	PERIODIC MAINTENANCE	52
C1730, C1731, C1732, C1733 FLAT TIRE	41	WHEEL	52
DTC Logic	41	Inspection	52
Diagnosis Procedure	41	WHEEL AND TIRE ASSEMBLY	53
C1734 BCM	43	Adjustment	53
DTC Logic	43	REMOVAL AND INSTALLATION	56
Diagnosis Procedure	43	TIRE PRESSURE SENSOR	56
C1735 IGNITION SIGNAL	45	Exploded View	56
DTC Logic	45	Removal and Installation	56
Diagnosis Procedure	45	TIRE PRESSURE RECEIVER	59
SYMPTOM DIAGNOSIS	47	Removal and Installation	59
TPMS	47	SERVICE DATA AND SPECIFICATIONS (SDS)	60
Symptom Table	47	SERVICE DATA AND SPECIFICATIONS (SDS)	60
LOW TIRE PRESSURE WARNING LAMP DOES NOT TURN ON	48	Road Wheel	60
Low Tire Pressure Warning Lamp Does Not Come On When Ignition Switch Is Turned On	48	Tire Air Pressure	60
LOW TIRE PRESSURE WARNING LAMP STAYS ON	49		

PRECAUTIONS

< PRECAUTION >

PRECAUTION

PRECAUTIONS

Precaution for Supplemental Restraint System (SRS) "AIR BAG" and "SEAT BELT PRE-TENSIONER"

INFOID:000000009729114

The Supplemental Restraint System such as "AIR BAG" and "SEAT BELT PRE-TENSIONER", used along with a front seat belt, helps to reduce the risk or severity of injury to the driver and front passenger for certain types of collision. This system includes dual stage front air bag modules. The SRS system may only deploy one front air bag, depending on the severity of a collision and whether the front passenger seat is occupied. Information necessary to service the system safely is included in the SR and SB section of this Service Manual.

WARNING:

- To avoid rendering the SRS inoperative, which could increase the risk of personal injury or death in the event of a collision which would result in air bag inflation, all maintenance must be performed by an authorized NISSAN/INFINITI dealer.
- Improper maintenance, including incorrect removal and installation of the SRS, can lead to personal injury caused by unintentional activation of the system. For removal of Spiral Cable and Air Bag Module, see the SR section.
- Do not use electrical test equipment on any circuit related to the SRS unless instructed to in this Service Manual. SRS wiring harnesses can be identified by yellow and/or orange harnesses or harness connectors.

PRECAUTIONS WHEN USING POWER TOOLS (AIR OR ELECTRIC) AND HAMMERS

WARNING:

- When working near the Airbag Diagnosis Sensor Unit or other Airbag System sensors with the Ignition ON or engine running, DO NOT use air or electric power tools or strike near the sensor(s) with a hammer. Heavy vibration could activate the sensor(s) and deploy the air bag(s), possibly causing serious injury.
- When using air or electric power tools or hammers, always switch the Ignition OFF, disconnect the battery and wait at least three minutes before performing any service.

Service Notice and Precautions for TPMS

INFOID:000000009134834

WARNING:

Radio waves could adversely affect electric medical equipment. Those who use a pacemaker should contact the electrical medical equipment manufacturer for the possible influences before use.

- Low tire pressure warning lamp blinks for 1 minute, then turns ON when any malfunction occurs except low tire pressure. Erase the self-diagnosis memories for Tire Pressure Monitoring System (TPMS), or register the ID to turn low tire pressure warning lamp OFF. For ID registration, refer to [WT-24, "Work Procedure"](#).
- ID registration is required when replacing or rotating wheels, replacing tire pressure sensor or BCM. Refer to [WT-24, "Work Procedure"](#).
- For easy fill tire alert function, refer to the following.
 - When inflating the tires, park the vehicle in the safe area and ensure the safety of the working area.
 - Read and understand the easy fill tire alert function prior to use.
 - Inflate the tires one at a time.
 - If there is no response for approximately 15 seconds or more after inflating the tires, cancel the use of the easy fill tire alert function or move the vehicle approximately 1 m (3.2 ft) backward or forward to try again. The air filler pressure may be weak or out of service area.
 - Despite the high-precision TPMS pressure sensor, an indicated value may differ from that of the pressure gauge.
 - Air pressure is measured rather high due to the rise in tire air temperature after driving.
 - If TPMS is malfunctioning, the easy fill tire alert is unusable.
- Replace grommet seal, valve core and valve cap of tire pressure sensor in TPMS when replacing each tire by reaching the wear limit. Refer to [WT-56, "Exploded View"](#).
- Because the tire pressure sensor conforms to North America radio law, the following items must be observed.
 - The sensor may be used only in North America.
 - It may not be used in any method other than the specified method.

PRECAUTIONS

< PRECAUTION >

- It must not be disassembled or modified.

Precautions for Road Wheel

INFOID:000000009134835

- Genuine NISSAN aluminum wheel is designed for each type of vehicle. Use it on the specified vehicle only.
- Use Genuine NISSAN parts for the wheel nuts.
- Always adjust the wheel balance prior to using them. For the balance weights, use Genuine NISSAN aluminum wheel weights.
- Use caution when handling the aluminum wheels because they can be easily scratched. When removing dirt, do not use any abrasives, a wire brush or other items that may scratch the coating. Use a neutral detergent if a detergent is needed.
- After driving on roads scattered with anti-icing salts, wash off the wheels completely.
- When installing road wheels onto the vehicle, always wipe off any dirt or foreign substances to prevent them from being trapped between the contact surfaces of wheel.
- Never apply oil to nut and bolt threads.

PREPARATION

< PREPARATION >



PREPARATION

PREPARATION

Special Service Tool

INFOID:000000009134836

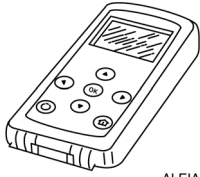
The actual shapes of Kent-Moore tools may differ from those of special service tools illustrated here.

Tool number (Kent-Moore No.) Tool name	Description
<p>— (J-50190) Signal Tech II</p>  <p>ALEIA0131ZZ</p>	<ul style="list-style-type: none"> • Activate and display TPMS transmitter IDs • Display tire pressure reported by the TPMS transmitter • Read TPMS DTCs • Register TPMS transmitter IDs • Test remote keyless entry keyfob relative signal strength
<p>— (J-45295-A) Transmitter activation tool</p>  <p>ALEIA0183ZZ</p>	<ul style="list-style-type: none"> • Activate TPMS transmitter IDs

Commercial Service Tool

INFOID:000000009134837

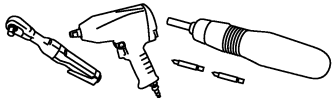
Tool name	Description
<p>Power tool</p>  <p>PIIB1407E</p>	<p>Loosening nuts, screws and bolts.</p>

A
B
C
D
WT
F
G
H
I
J
K
L
M
N
O
P

COMPONENT PARTS

< SYSTEM DESCRIPTION >

SYSTEM DESCRIPTION

COMPONENT PARTS

Component Parts Location

INFOID:000000009134838

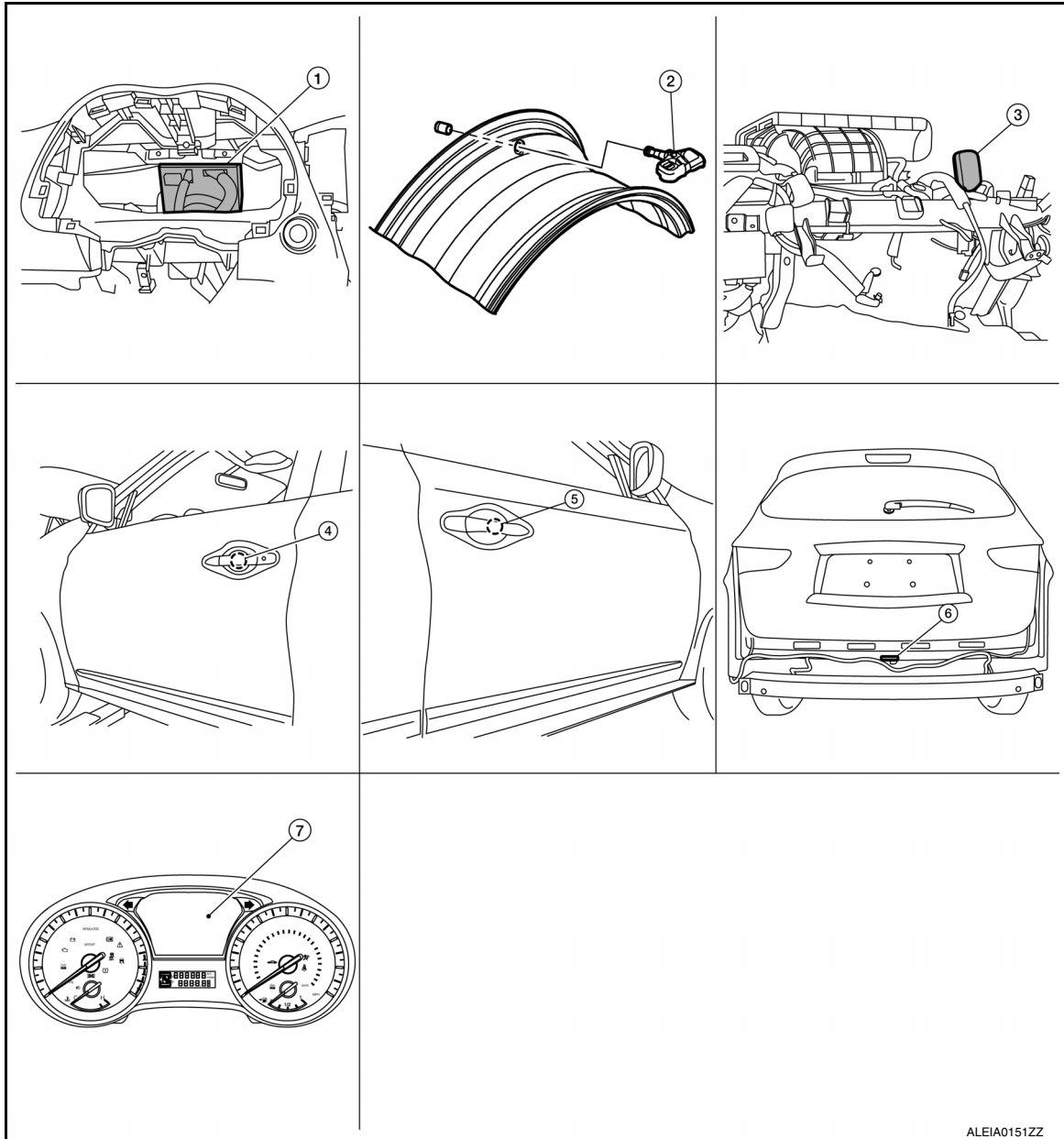

ALEIA0151ZZ

1. BCM (view with combination meter removed)
2. Transmitter
3. Remote keyless entry receiver (view with instrument panel removed)
4. Outside key antenna (driver side) (part of outside door handle grip)
5. Outside key antenna (passenger side) (part of outside door handle grip)
6. Outside key antenna (rear bumper) (view with rear bumper fascia removed)
7. Combination meter

COMPONENT PARTS

< SYSTEM DESCRIPTION >

Component Description

INFOID:000000009134839

Component parts	Reference/Function
BCM	WT-7, "BCM"
Transmitter	WT-7, "Transmitter"
Remote keyless entry receiver	WT-7, "Remote Keyless Entry Receiver"
Outside key antennas	WT-7, "Outside Key Antennas"
Combination meter	WT-7, "Combination Meter"

BCM

INFOID:000000009134840

The BCM reads the air pressure signal received by the remote keyless entry receiver. In addition, the BCM also uses the outside key antennas (driver side, passenger side and rear bumper) to identify the location of the transmitters.

The BCM has a self-diagnosis function used to detect system malfunctions.

Transmitter

INFOID:000000009134841

A sensor-transmitter integrated with a valve is installed in each wheel, and transmits a detected air pressure signal in the form of a radio wave. The radio signal is received by the remote keyless entry receiver.

Remote Keyless Entry Receiver

INFOID:000000009134842

The remote keyless entry receiver receives the air pressure signal transmitted by the transmitter in each wheel.

Outside Key Antennas

INFOID:000000009134843

The outside key antennas (driver side, passenger side and rear bumper) are used by the BCM to identify the location of the transmitters.

Combination Meter

INFOID:000000009134844

The combination meter receives tire pressure status from the BCM via CAN communication. The combination meter will display the low tire pressure warning lamp when a low tire pressure or system malfunction is detected by the BCM. A warning message will also be displayed in the vehicle information display. Refer to the Owner's Manual for additional information.

A
B
C
D
E
F
G
H
I
J
K
L
M
N
O
P

WT

SYSTEM

< SYSTEM DESCRIPTION >

SYSTEM

System Diagram

INFOID:000000009134845

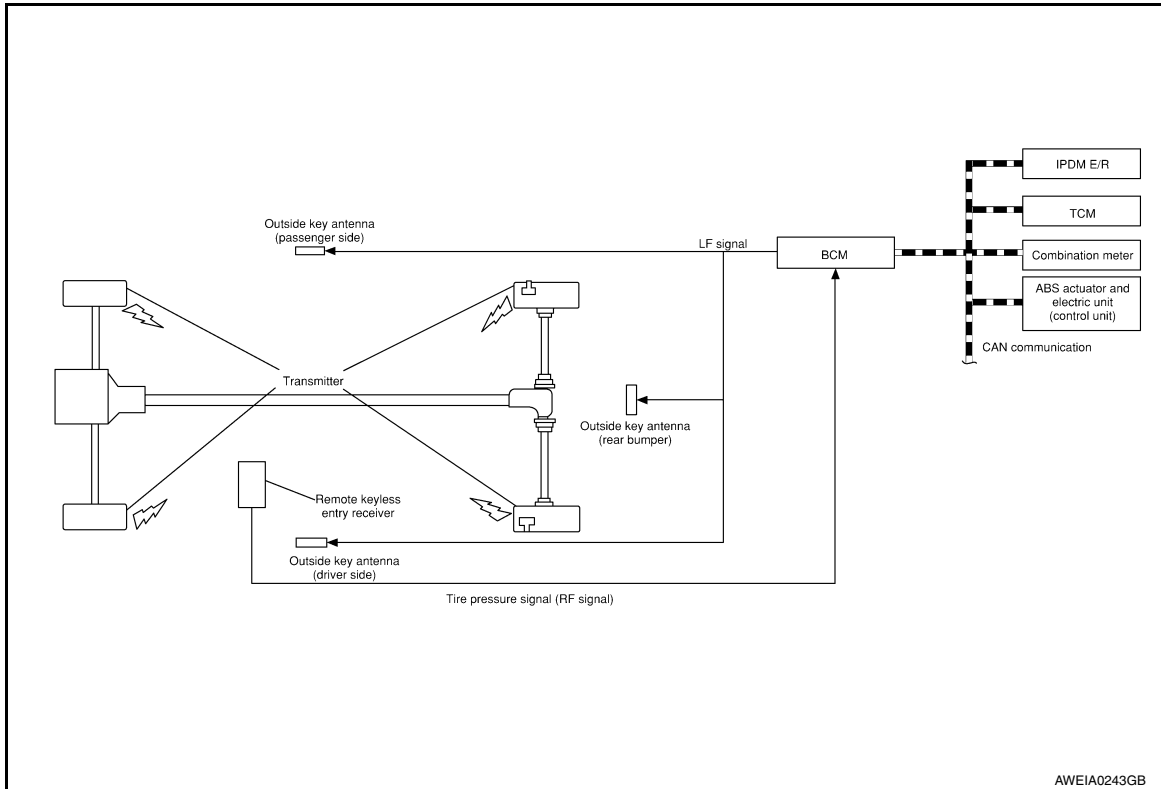

AWEIA0243GB

System Description

INFOID:000000009134846

When the vehicle has reached a speed of 40 km/h (25 MPH) or greater, the BCM receives a signal transmitted from the tire pressure sensors/transmitters installed in each wheel. If the BCM detects low inflation pressure or a system malfunction, it sends a signal to the combination meter via CAN communication to illuminate the low tire pressure warning lamp. In addition, a warning message will be displayed in the vehicle information display. Refer to the Owner's Manual for additional information.

The tire pressure monitoring system (TPMS) has a tire inflation indicator function to aid in tire inflation. Refer to [WT-8, "Tire Inflation Indicator Function"](#).

Low Tire Pressure Warning Lamp Indication

Condition	Low tire pressure warning lamp
Ignition switch OFF	OFF
Ignition switch ON (system normal)	Warning lamp turns on for 1second, then turns off.
Low tire pressure	ON
Tire pressure sensor/transmitter ID not registered in BCM	
TPMS malfunction	Warning lamp blinks 1 min, then turns on.

Tire Inflation Indicator Function

INFOID:000000009134847

NOTE:

When beginning tire inflation, it takes a few seconds for the tire inflation indicator to function. If there is no response for approximately 15 seconds or more, cancel the tire inflation indicator function and move the vehicle approximately 1 m (3.2 ft) backward or forward to try again.

- The tire inflation indicator function operates only when the select lever position is in P-range with the ignition switch ON.

SYSTEM

< SYSTEM DESCRIPTION >

- This function informs the driver with a visual and audible indication that the recommended COLD tire pressure has been reached.
- The hazard warning lamps blink when the recommended COLD tire pressure has been reached. After the recommended COLD tire pressure has been reached, the horn sounds once and the hazard warning lamps stop blinking.
- If the tire pressure value is equal to or greater than 30 kPa (0.31 kg/cm², 4 psi) more than the recommended COLD tire pressure, the hazard warning lamps flash and horn sounds three times.
- To return the tire to the recommended COLD tire pressure, deflate the tire until the horn sounds once and the hazard warning lamps stop blinking.

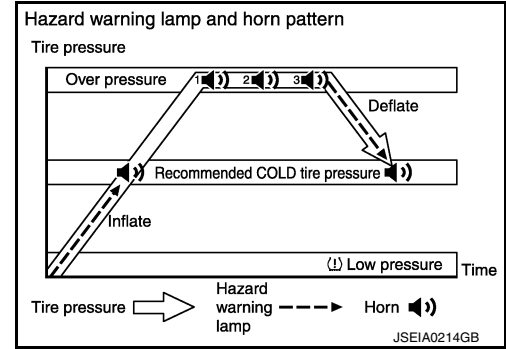

A
B
C
D

WT

F
G
H
I
J
K
L
M
N
O
P

DIAGNOSIS SYSTEM (BCM)

< SYSTEM DESCRIPTION >

DIAGNOSIS SYSTEM (BCM)

COMMON ITEM

COMMON ITEM : CONSULT Function (BCM - COMMON ITEM)

INFOID:000000009709638

CAUTION:

After disconnecting the CONSULT vehicle interface (VI) from the data link connector, the ignition must be cycled OFF → ON (for at least 5 seconds) → OFF. If this step is not performed, the BCM may not go to "sleep mode", potentially causing a discharged battery and no-start condition.

APPLICATION ITEM

CONSULT performs the following functions via CAN communication with BCM.

Direct Diagnostic Mode	Description
Ecu Identification	The BCM part number is displayed.
Self Diagnostic Result	The BCM self diagnostic results are displayed.
Data Monitor	The BCM input/output data is displayed in real time.
Active Test	The BCM activates outputs to test components.
Work support	The settings for BCM functions can be changed.
Configuration	<ul style="list-style-type: none"> The vehicle specification can be read and saved. The vehicle specification can be written when replacing BCM.
CAN Diag Support Mntr	The result of transmit/receive diagnosis of CAN communication is displayed.

SYSTEM APPLICATION

BCM can perform the following functions.

System	Sub System	Direct Diagnostic Mode						
		Ecu Identification	Self Diagnostic Result	Data Monitor	Active Test	Work support	Configuration	CAN Diag Support Mntr
Door lock	DOOR LOCK		×	×	×	×		
Rear window defogger	REAR DEFOGGER			×	×	×		
Warning chime	BUZZER			×	×			
Interior room lamp timer	INT LAMP			×	×	×		
Exterior lamp	HEADLAMP			×	×	×		
Wiper and washer	WIPER			×	×	×		
Turn signal and hazard warning lamps	FLASHER			×	×			
Air conditioner	AIR CONDITIONER			×				
Intelligent Key system	INTELLIGENT KEY		×	×	×	×		
Combination switch	COMB SW			×				
BCM	BCM	×	×			×	×	×
Immobilizer	IMMU		×	×	×			
Interior room lamp battery saver	BATTERY SAVER			×	×			
Back door open	TRUNK			×				
Vehicle security system	THEFT ALM			×	×	×		
RAP system	RETAINED PWR			×				

DIAGNOSIS SYSTEM (BCM)

< SYSTEM DESCRIPTION >

System	Sub System	Direct Diagnostic Mode						
		Ecu Identification	Self Diagnostic Result	Data Monitor	Active Test	Work support	Configuration	CAN Diag Support Mntr
Signal buffer system	SIGNAL BUFFER			×				
TPMS	AIR PRESSURE MONITOR		×	×	×	×		

AIR PRESSURE MONITOR

AIR PRESSURE MONITOR : CONSULT Function (BCM-AIR PRESSURE MONITOR)

INFOID:000000009709639

CAUTION:

After disconnecting the CONSULT vehicle interface (VI) from the data link connector, the ignition must be cycled OFF → ON (for at least 5 seconds) → OFF. If this step is not performed, the BCM may not go to "sleep mode", potentially causing a discharged battery and no-start condition.

NOTE:

The Signal Tech II Tool (J-50190) can be used to perform the following functions. Refer to the Signal Tech II User Guide for additional information.

- Activate and display TPMS transmitter IDs
- Display tire pressure reported by the TPMS transmitter
- Read TPMS DTCs
- Register TPMS transmitter IDs
- Check Intelligent Key relative signal strength
- Confirm vehicle Intelligent Key antenna signal strength

SELF DIAGNOSTIC RESULT

NOTE:

Before performing Self Diagnostic Result, be sure to register the transmitter ID or the actual malfunction may be different from that displayed on CONSULT.

Refer to [BCS-51, "DTC Index"](#).

DATA MONITOR

Monitor Item [Unit]	Description
AIR PRESS FL [kPa, kg/cm ² or Psi]	Indicates air pressure of front LH tire.
AIR PRESS FR [kPa, kg/cm ² or Psi]	Indicates air pressure of front RH tire.
AIR PRESS RR [kPa, kg/cm ² or Psi]	Indicates air pressure of rear RH tire.
AIR PRESS RL [kPa, kg/cm ² or Psi]	Indicates air pressure of rear LH tire.
ID REGST FL1 [Done/Yet]	Indicates ID registration status of front LH transmitter.
ID REGST FR1 [Done/Yet]	Indicates ID registration status of front RH transmitter.
ID REGST RR1 [Done/Yet]	Indicates ID registration status of rear RH transmitter.
ID REGST RL1 [Done/Yet]	Indicates ID registration status of rear LH transmitter.
WARNING LAMP [Off/On]	Indicates condition of low tire pressure warning lamp in combination meter.
BUZZER [Off/On]	Indicates condition of buzzer in combination meter.

ACTIVE TEST

DIAGNOSIS SYSTEM (BCM)

< SYSTEM DESCRIPTION >

Test Item	Description
FLASHER	This test is able to check turn signal lamp operation [Off/LH/RH].
HORN	This test is able to check horn operation [On].
WARNING LAMP	This test is able to check tire pressure warning lamp operation [On/Off].
ID REGIST WARNING	This test is able to check ID regist warning chime operation [On/Off].
RUN FLAT/T WARN BUZZER	This test is able to check tire warning buzzer operation [On/Off].

WORK SUPPORT

Support Item	Description
ID READ	The registered ID number is displayed.
ID REGIST	Refer to WT-24. "Description" .

BCM

< ECU DIAGNOSIS INFORMATION >

ECU DIAGNOSIS INFORMATION

BCM

List of ECU Reference

INFOID:000000009134850

ECU	Reference
BCM	BCS-29, "Reference Value"
	BCS-49, "Fail Safe"
	BCS-49, "DTC Inspection Priority Chart"
	BCS-51, "DTC Index"

A
B
C
D
WT
F
G
H
I
J
K
L
M
N
O
P

TIRE PRESSURE MONITORING SYSTEM

< WIRING DIAGRAM >

OB > WITHOUT BOSE AUDIO SYSTEM
WB > WITH BOSE AUDIO SYSTEM

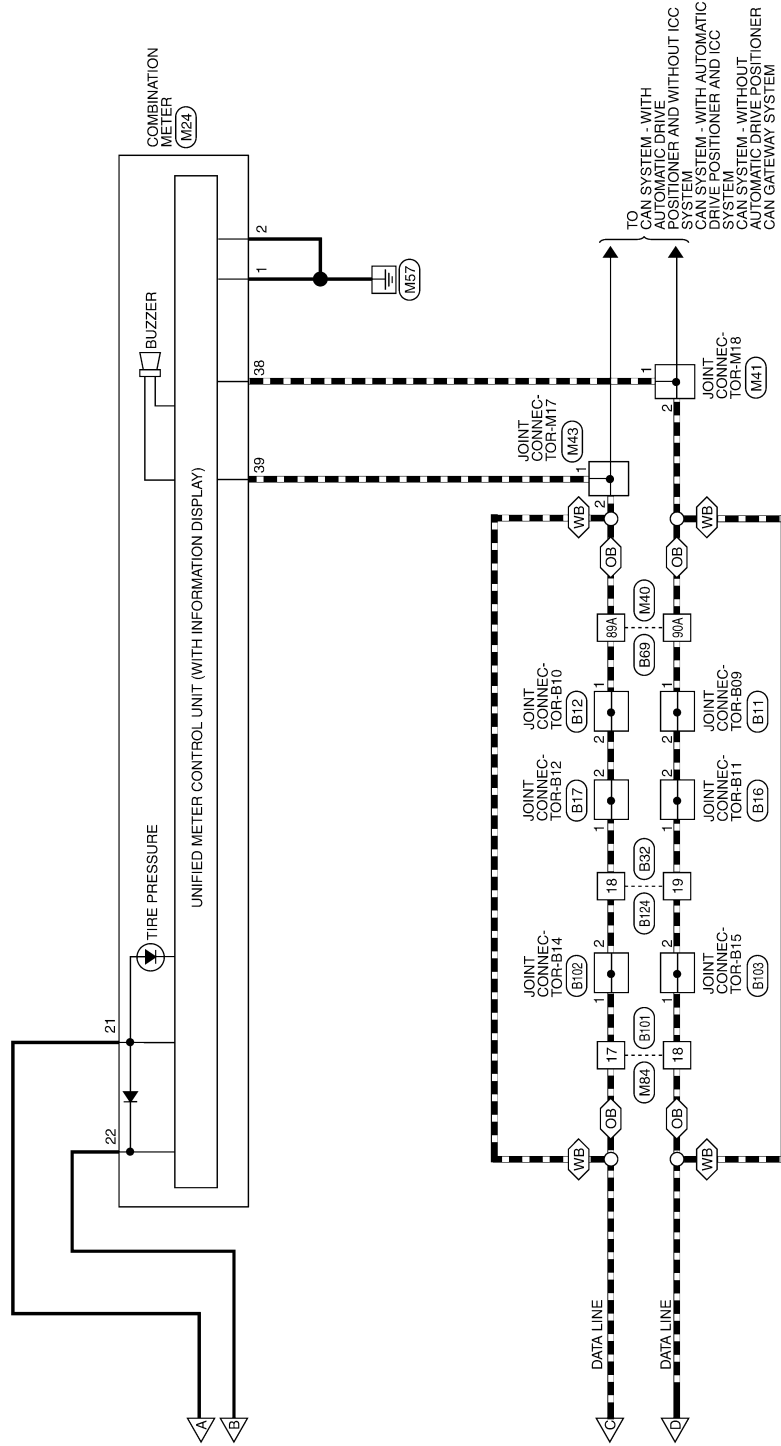

ABEWA0096GB

A
B
C
D
WT
F
G
H
I
J
K
L
M
N
O
P

TIRE PRESSURE MONITORING SYSTEM

< WIRING DIAGRAM >

TIRE PRESSURE MONITORING SYSTEM CONNECTORS

Connector No.	M3
Connector Name	FUSE BLOCK (J/B)
Connector Color	WHITE

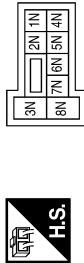

Terminal No.	Color of Wire	Signal Name
2N	BG	-
6N	W	-

Connector No.	M4
Connector Name	FUSE BLOCK (J/B)
Connector Color	WHITE

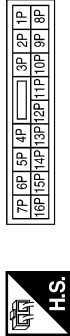

Terminal No.	Color of Wire	Signal Name
8P	BG	-
13P	W	-

Connector No.	M19
Connector Name	BCM (BODY CONTROL MODULE)
Connector Color	BLACK



60	59	58	57	56	55	54	53	52	51	50	49	48	47	46	45	44	43	42	41
80	79	78	77	76	75	74	73	72	71	70	69	68	67	66	65	64	63	62	61

Terminal No.	Color of Wire	Signal Name
59	P	CAN-L
60	L	CAN-H

Connector No.	M20
Connector Name	BCM (BODY CONTROL MODULE)
Connector Color	GRAY

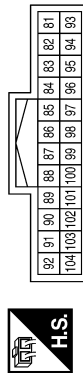

Terminal No.	Color of Wire	Signal Name
101	R	REAR BUMPER ANT B
102	G	REAR BUMPER ANT A

Connector No.	M24
Connector Name	COMBINATION METER
Connector Color	WHITE

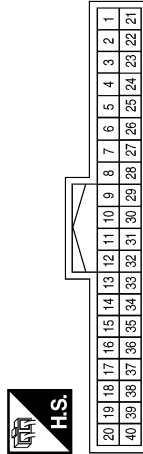

Terminal No.	Color of Wire	Signal Name
1	B	GND1
2	B	GND2
21	BG	IGN
22	W	BAT
38	P	CAN-L
39	L	CAN-H

TIRE PRESSURE MONITORING SYSTEM

< WIRING DIAGRAM >

Terminal No.	Color of Wire	Signal Name
16A	G	-
89A	L	-
90A	P	-

Connector No.	M40
Connector Name	WIRE TO WIRE
Connector Color	GRAY

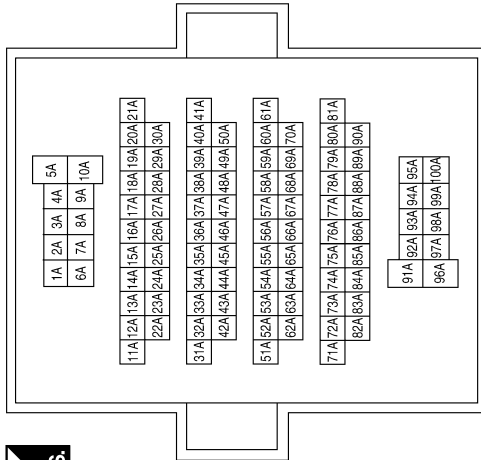

Terminal No.	Color of Wire	Signal Name
15A	R	-

Connector No.	M43
Connector Name	JOINT CONNECTOR-M17
Connector Color	WHITE



Terminal No.	Color of Wire	Signal Name
1	L	-
2	L	-

Connector No.	M31
Connector Name	WIRE TO WIRE
Connector Color	WHITE

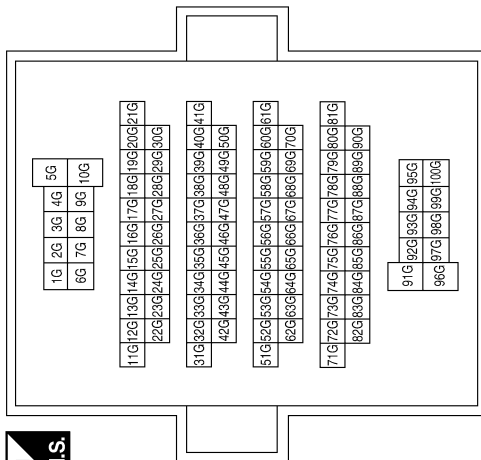

Terminal No.	Color of Wire	Signal Name
10G	W	-

Connector No.	M41
Connector Name	JOINT CONNECTOR-M18
Connector Color	WHITE



Terminal No.	Color of Wire	Signal Name
1	P	-
2	P	-

ABEIA0209GB

A
B
C
D
E
F
G
H
I
J
K
L
M
N
O
P

WT

TIRE PRESSURE MONITORING SYSTEM

< WIRING DIAGRAM >

Connector No.	M84
Connector Name	WIRE TO WIRE
Connector Color	WHITE



16	15	14	13	12	11	10	9	8	7	6	5	4	3	2	1
32	31	30	29	28	27	26	25	24	23	22	21	20	19	18	17

Terminal No.	Color of Wire	Signal Name
17	L	-
18	P	-

Connector No.	M81
Connector Name	BCM (BODY CONTROL MODULE)
Connector Color	WHITE



137	136	135	134	133	132	131	130	129
143	142	141	140	139	138			

Terminal No.	Color of Wire	Signal Name
131	W	BAT BCM FUSE
134	B	GND 2
139	W	BAT POWER F/L
143	B	GND 1

Connector No.	M80
Connector Name	BCM (BODY CONTROL MODULE)
Connector Color	BLACK



116	115	114	113	112	111	110	109	108	107	106	105
128	127	126	125	124	123	122	121	120	119	118	117

Terminal No.	Color of Wire	Signal Name
114	W	AS DOOR ANT A
115	BG	AS DOOR ANT B
119	R	RF NIMOCO
121	G	DR DOOR ANT B
122	P	DR DOOR ANT A

Connector No.	M168
Connector Name	WIRE TO WIRE
Connector Color	WHITE



1	2	3	4	5	6	7	8	9	10	11	12	13	14	15	16	17	18	19	20
21	22	23	24	25	26	27	28	29	30	31	32	33	34	35	36	37	38	39	40

Terminal No.	Color of Wire	Signal Name
11	G	-
12	P	-

Connector No.	M91
Connector Name	WIRE TO WIRE
Connector Color	WHITE



1	2	3	4	5	6	7	8	9	10	11	12	13	14	15	16
17	18	19	20	21	22	23	24	25	26	27	28	29	30	31	32

Terminal No.	Color of Wire	Signal Name
25	BG	-
26	W	-

Connector No.	M86
Connector Name	REMOTE KEYLESS ENTRY RECEIVER
Connector Color	BLACK



1	2	3	4
---	---	---	---

Terminal No.	Color of Wire	Signal Name
1	BG	-
2	R	-
3	GR	-

ABEIA0210GB

TIRE PRESSURE MONITORING SYSTEM

< WIRING DIAGRAM >

Terminal No.	Color of Wire	Signal Name
10G	P	-

Connector No.	E152
Connector Name	WIRE TO WIRE
Connector Color	WHITE

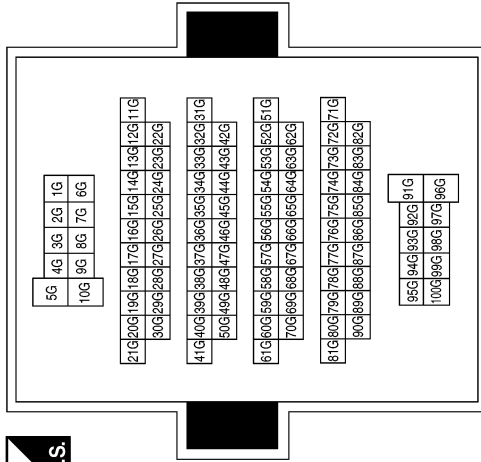

Connector No.	M181
Connector Name	JOINT CONNECTOR-M36
Connector Color	WHITE

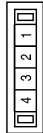

Terminal No.	Color of Wire	Signal Name
1	W	-
2	W	-

Connector No.	B16
Connector Name	JOINT CONNECTOR-B11
Connector Color	WHITE



Terminal No.	Color of Wire	Signal Name
1	P	-
2	P	-

Connector No.	B12
Connector Name	JOINT CONNECTOR-B10
Connector Color	WHITE



Terminal No.	Color of Wire	Signal Name
1	L	-
2	L	-

Connector No.	B11
Connector Name	JOINT CONNECTOR-B09
Connector Color	WHITE



Terminal No.	Color of Wire	Signal Name
1	P	-
2	P	-

ABEIA0142GB

A
B
C
D
WT
F
G
H
I
J
K
L
M
N
O
P

TIRE PRESSURE MONITORING SYSTEM

< WIRING DIAGRAM >

Connector No.	B17
Connector Name	JOINT CONNECTOR-B12
Connector Color	WHITE



Terminal No.	Color of Wire	Signal Name
1	L	-
2	L	-

Connector No.	B32
Connector Name	WIRE TO WIRE
Connector Color	WHITE

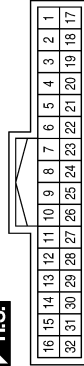

Terminal No.	Color of Wire	Signal Name
18	L	-
19	P	-

Connector No.	B69
Connector Name	WIRE TO WIRE
Connector Color	GRAY

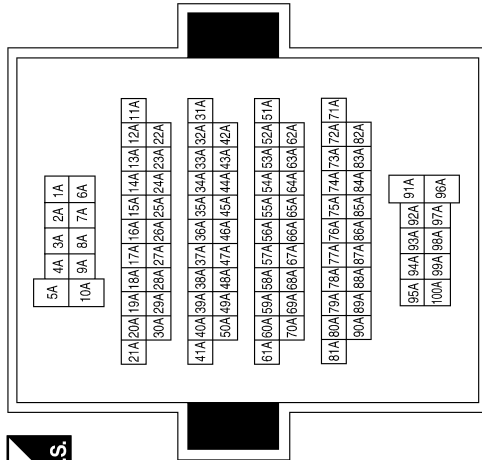

Terminal No.	Color of Wire	Signal Name
15A	G	-
16A	W	-
89A	L	-
90A	P	-

Connector No.	B77
Connector Name	WIRE TO WIRE
Connector Color	WHITE

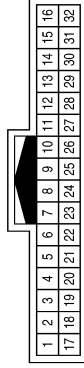

Terminal No.	Color of Wire	Signal Name
9	W	-
10	G	-

ABEIA0211GB

TIRE PRESSURE MONITORING SYSTEM

< WIRING DIAGRAM >

Connector No.	B101
Connector Name	WIRE TO WIRE
Connector Color	WHITE



1	2	3	4	5	6	7	8	9	10	11	12	13	14	15	16
17	18	19	20	21	22	23	24	25	26	27	28	29	30	31	32

Terminal No.	Color of Wire	Signal Name
17	L	-
18	P	-

Connector No.	B102
Connector Name	JOINT CONNECTOR-B14
Connector Color	WHITE



4	3	2	1	0
---	---	---	---	---

Terminal No.	Color of Wire	Signal Name
1	L	-
2	L	-

Connector No.	B103
Connector Name	JOINT CONNECTOR-B15
Connector Color	WHITE



4	3	2	1	0
---	---	---	---	---

Terminal No.	Color of Wire	Signal Name
1	P	-
2	P	-

Connector No.	B124
Connector Name	WIRE TO WIRE
Connector Color	WHITE



1	2	3	4	5	6	7	8	9	10	11	12	13	14	15	16
17	18	19	20	21	22	23	24	25	26	27	28	29	30	31	32

Terminal No.	Color of Wire	Signal Name
18	L	-
19	P	-

Connector No.	B400
Connector Name	WIRE TO WIRE
Connector Color	WHITE



16	15	14	13	12	11	10	9	8	7	6	5	4	3	2	1
32	31	30	29	28	27	26	25	24	23	22	21	20	19	18	17

Terminal No.	Color of Wire	Signal Name
9	W	-
10	G	-

Connector No.	B403
Connector Name	OUTSIDE KEY ANTENNA (REAR BUMPER)
Connector Color	GRAY



1	2
---	---

Terminal No.	Color of Wire	Signal Name
1	W	-
2	G	-

ABEIA0144GB

A B C D E F G H I J K L M N O P

WT

TIRE PRESSURE MONITORING SYSTEM

< WIRING DIAGRAM >

Connector No.	D101
Connector Name	WIRE TO WIRE
Connector Color	WHITE



16	15	14	13	12	11	10	9	8	7	6	5	4	3	2	1
32	31	30	29	28	27	26	25	24	23	22	21	20	19	18	17

Terminal No.	Color of Wire	Signal Name
25	Y	-
26	LG	-

Connector No.	D5
Connector Name	OUTSIDE KEY ANTENNA (DRIVER SIDE)
Connector Color	GRAY



Terminal No.	Color of Wire	Signal Name
1	LG	-
2	Y	-

Connector No.	D3
Connector Name	WIRE TO WIRE
Connector Color	WHITE



20	19	18	17	16	15	14	13	12	11	10	9	8	7	6	5	4	3	2	1
40	39	38	37	36	35	34	33	32	31	30	29	28	27	26	25	24	23	22	21

Terminal No.	Color of Wire	Signal Name
11	Y	-
12	LG	-

Connector No.	D118
Connector Name	OUTSIDE KEY ANTENNA (PASSENGER SIDE)
Connector Color	GRAY



Terminal No.	Color of Wire	Signal Name
1	LG	-
2	Y	-

ABEIA0212GB

DIAGNOSIS AND REPAIR WORK FLOW

< BASIC INSPECTION >

BASIC INSPECTION

DIAGNOSIS AND REPAIR WORK FLOW

Work Flow

INFOID:000000009134852

NOTE:

The Signal Tech II Tool (J-50190) can be used to perform the following functions. Refer to the Signal Tech II User Guide for additional information.

- Activate and display TPMS transmitter IDs
- Display tire pressure reported by the TPMS transmitter
- Read TPMS DTCs
- Register TPMS transmitter IDs

1. COLLECT INFORMATION FROM CUSTOMER

Get detailed information from the customer about the symptom (the condition and the environment when the incident/malfunction occurred).

>> GO TO 2.

2. TIRE PRESSURE INSPECTION

Check the tire pressure for all wheels. Refer to [WT-60, "Tire Air Pressure"](#).

Is the inspection result normal?

YES >> GO TO 3.

NO >> Repair or replace tire(s) or wheel(s).

3. CHECK LOW TIRE PRESSURE WARNING LAMP

Check that the low tire pressure warning lamp illuminates for approximately 1 second after the ignition switch is turned ON, then turns OFF.

Does the low tire pressure warning lamp turn OFF?

YES >> Inspection End.

NO >> GO TO 4.

4. PERFORM SELF DIAGNOSTIC RESULT

Perform self diagnostic result. Refer to [BCS-27, "AIR PRESSURE MONITOR : CONSULT Function \(BCM-AIR PRESSURE MONITOR\)"](#).

Are any DTCs displayed?

YES >> Refer to [BCS-51, "DTC Index"](#). If two or more DTCs are displayed, refer to [BCS-49, "DTC Inspection Priority Chart"](#).

NO >> GO TO 5.

5. PERFORM DIAGNOSIS APPLICABLE TO THE SYMPTOM

Perform diagnosis applicable to the symptom. Refer to [WT-47, "Symptom Table"](#).

>> GO TO 6.

6. FINAL CHECK

Perform self diagnostic result again, and check that the malfunction is repaired. After checking, erase the self diagnosis memory. Refer to [BCS-27, "AIR PRESSURE MONITOR : CONSULT Function \(BCM-AIR PRESSURE MONITOR\)"](#).

>> Inspection End.

ID REGISTRATION PROCEDURE

< BASIC INSPECTION >

ID REGISTRATION PROCEDURE

Description

INFOID:000000009134855

This procedure must be performed:

- after replacement of a transmitter or BCM (with individual tire pressure display).
- after replacement of a transmitter, BCM or rotation of the wheels (without individual tire pressure display).

Work Procedure

INFOID:000000009134856

TPMS ID registration can be performed using one of the following procedures:

- Transmitter Activation tool (J-45295-A) with CONSULT (preferred method)
- Signal Tech II tool (J-50190) with CONSULT (preferred method)
- Signal Tech II tool (J-50190) without CONSULT
- CONSULT only

TPMS REGISTRATION WITH TRANSMITTER ACTIVATION TOOL (J-45295-A)

Ⓟ With CONSULT

1. Turn the ignition switch ON.
2. Using CONSULT, select "WORK SUPPORT" in BCM (AIR PRESSURE MONITOR). Then, select "ID REGIST."
3. Select "Start" on "ID REGIST" screen.
4. Hold the transmitter activation tool (J-45295-A) (1) against the side of the left front tire, near the valve stem.
5. With the tool held at a 0 to 15 degree angle to the tire, press and hold the transmitter activation tool button until the indicator lamp turns OFF (approximately 5 seconds).
6. Repeat steps 4 and 5 for the remaining tires in this order: right front, right rear and left rear.

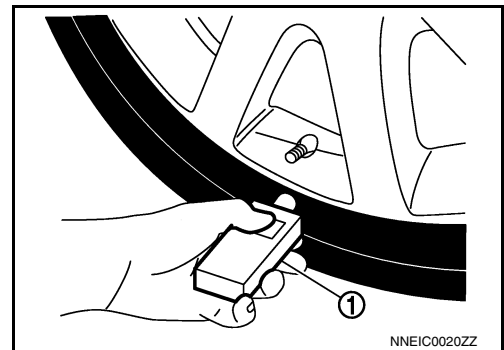

7. When ID registration is complete, check the following pattern at each wheel.

Sequence	ID registration position	Turn signal lamp	CONSULT
1	Front LH	2 blinks	"Yet (red)" ↓ "Done (green)"
2	Front RH		
3	Rear RH		
4	Rear LH		

8. After the ID registration procedure for all wheels is complete, press "End" on the CONSULT to finish ID registration.
9. Test drive the vehicle to ensure that the TPMS lamp is OFF and no warning messages are present.

TPMS REGISTRATION WITH SIGNAL TECH II TOOL (J-50190)

NOTE:

The Signal Tech II must be updated with software version 1.1.48 or newer in order to perform the below procedures. The Signal Tech II software updates can only be downloaded from a CONSULT unit with ASIST. Other versions of ASIST will not show the updates.

Ⓟ With CONSULT

1. Adjust the tire pressure for all tires to the recommended value. Refer to [WT-60. "Tire Air Pressure"](#).
2. Turn the ignition switch ON.
3. Using CONSULT, select "WORK SUPPORT" in BCM (AIR PRESSURE MONITOR). Then, select "ID REGIST."
4. Select "Start" on "ID REGIST" screen.

ID REGISTRATION PROCEDURE

< BASIC INSPECTION >

5. Turn on the Signal Tech II tool (J-50190).
6. Hold the Signal Tech II against the side of the left front tire, near the valve stem.
7. With the tool held at a 0 to 15 degree angle to the tire, select "Activate Sensor" from the main menu, then press and release the "OK" button to activate the sensor. Once the sensor is activated, the vehicle parking lamps will flash and the sensor ID will appear on the CONSULT screen.
8. Repeat steps 6 and 7 for the remaining tires in this order: right front, right rear and left rear.
9. When ID registration is complete, check the following pattern at each wheel.

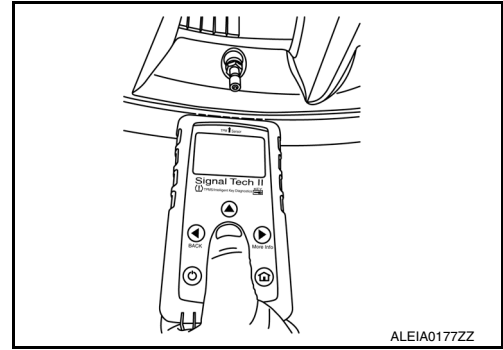

Sequence	ID registration position	Turn signal lamp	CONSULT
1	Front LH	2 blinks	"Yet (red)" ↓ "Done (green)"
2	Front RH		
3	Rear RH		
4	Rear LH		

10. Once all sensors have been activated, select "End" on the CONSULT to finish ID registration.
11. Test drive the vehicle to ensure that the TPMS lamp is OFF and no warning messages are present.

⊗ Without CONSULT

1. Adjust the tire pressure for all tires to the recommended value. Refer to [WT-60, "Tire Air Pressure"](#).
2. Turn on the Signal Tech II tool (J-50190) and select "TPMS Check" from the main menu.
3. Select vehicle model and year.
4. When prompted, hold the Signal Tech II against the side of the left front tire, near the valve stem.
5. With the tool held at a 0 to 15 degree angle to the tire, press and release the "OK" button to activate the sensor. Once the sensor is activated, the tool will sound a tone and the tire pressure will be displayed.
6. Repeat steps 4 and 5 for the remaining tires in this order: right front, right rear and left rear.
7. When prompted, connect the tool to the data link connector. The tool will connect to the BCM, read the VIN, read sensor IDs and check for TPMS DTCs. Along with DTCs detected, one of the following will be displayed next to each wheel:
 - N/A - Not applicable because no ID found by the tool
 - OK - Wheel and sensor are in original position
 - NEW - New ID found compared to BCM
 - RT - Wheel has been rotated
 - Low Press - Low tire pressure
8. If no DTC is present or the repair has been completed, press the "OK" button to register the IDs and clear DTCs.
9. Test drive the vehicle to ensure that the TPMS lamp is OFF and no warning messages are present.
10. Print a Signal Tech II Audit Report for your records. Refer to the Signal Tech II User Guide for instructions.

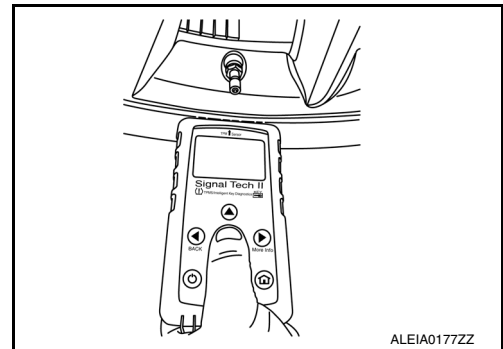

TPMS REGISTRATION WITH CONSULT ONLY

Ⓟ With CONSULT

1. Adjust the tire pressure for all wheels to match the list below.

Tire position	Tire pressure kPa (kg/cm ² , psi)
Front LH	240 (2.4, 35)
Front RH	220 (2.2, 32)

ID REGISTRATION PROCEDURE

< BASIC INSPECTION >

Tire position	Tire pressure kPa (kg/cm ² , psi)
Rear RH	200 (2.0, 29)
Rear LH	180 (1.8, 26)

- Turn the ignition switch ON.
- Using CONSULT, select "WORK SUPPORT" in BCM (AIR PRESSURE MONITOR). Then, select "ID REGIST."
- Select "Start" on "ID REGIST" screen.
- Drive the vehicle at a speed greater than 40 km/h (25 MPH) for 3 minutes or more.
- After ID registration for all wheels is complete, press "End" on the CONSULT to finish ID registration.

ID registration position	CONSULT
Front LH	
Front RH	"Yet (red)"
Rear RH	↓
Rear LH	"Done (green)"

- Adjust the tire pressures for all tires to the recommended value. Refer to [WT-60, "Tire Air Pressure"](#).
- Test drive the vehicle to ensure that the TPMS lamp is OFF and no warning messages are present.

C1704, C1705, C1706, C1707 LOW TIRE PRESSURE

< DTC/CIRCUIT DIAGNOSIS >

DTC/CIRCUIT DIAGNOSIS

C1704, C1705, C1706, C1707 LOW TIRE PRESSURE

DTC Logic

INFOID:000000009134857

NOTE:

The Signal Tech II Tool (J-50190) can be used to perform the following functions. Refer to the Signal Tech II User Guide for additional information.

- Activate and display TPMS transmitter IDs
- Display tire pressure reported by the TPMS transmitter
- Read TPMS DTCs
- Register TPMS transmitter IDs

DTC DETECTION LOGIC

CONSULT Display	DTC Detection Condition	Possible Cause
LOW PRESSURE FL [C1704]	Front LH tire pressure drops to 189.6 kPa (1.9 kg/cm ² , 27 psi) or less.	• Low tire pressure • Tire pressure sensor
LOW PRESSURE FR [C1705]	Front RH tire pressure drops to 189.6 kPa (1.9 kg/cm ² , 27 psi) or less.	
LOW PRESSURE RR [C1706]	Rear RH tire pressure drops to 189.6 kPa (1.9 kg/cm ² , 27 psi) or less.	
LOW PRESSURE RL [C1707]	Rear LH tire pressure drops to 189.6 kPa (1.9 kg/cm ² , 27 psi) or less.	

DTC CONFIRMATION PROCEDURE

1. PERFORM SELF DIAGNOSTIC RESULT

With CONSULT

1. Check tire pressure for all wheels and adjust to the specified value. Refer to [WT-60, "Tire Air Pressure"](#).
2. Drive at a speed of 40 km/h (25 MPH) or more for 3 minutes, and then drive the vehicle at any speed for 10 minutes.
3. Perform Self Diagnostic Result.

Is DTC C1704, C1705, C1706, or C1707 detected?

- YES >> Proceed to [WT-27, "Diagnosis Procedure"](#).
NO >> Inspection End.

Diagnosis Procedure

INFOID:000000009134858

NOTE:

The Signal Tech II Tool (J-50190) can be used to perform the following functions. Refer to the Signal Tech II User Guide for additional information.

- Activate and display TPMS transmitter IDs
- Display tire pressure reported by the TPMS transmitter
- Read TPMS DTCs
- Register TPMS transmitter IDs

1. TIRE PRESSURE SENSOR ID REGISTRATION

Perform tire pressure sensor ID registration. Refer to [WT-24, "Work Procedure"](#).

Can the tire pressure sensor ID registration be completed?

- YES >> GO TO 2.
NO >> Replace applicable tire pressure sensor. Refer to [WT-56, "Removal and Installation"](#).

2. CHECK TIRE PRESSURE

Check the air pressure of all wheels. Refer to [WT-60, "Tire Air Pressure"](#).

Is the inspection result normal?

C1704, C1705, C1706, C1707 LOW TIRE PRESSURE

< DTC/CIRCUIT DIAGNOSIS >

- YES >> Perform DTC CONFIRMATION PROCEDURE again. Refer to [WT-27. "DTC Logic"](#).
NO >> GO TO 3.

3. CHECK TIRE PRESSURE SIGNAL

With CONSULT

1. Adjust tire pressure for all wheels to the specified value. Refer to [WT-60. "Tire Air Pressure"](#).
2. Select Data Monitor from AIR PRESSURE MONITOR of BCM.
3. Check that the air pressures match the specified value.

Monitor item	Displayed value
AIR PRESS FL	Approximately equal to value indicated on tire gauge for front LH tire
AIR PRESS FR	Approximately equal to value indicated on tire gauge for front RH tire
AIR PRESS RR	Approximately equal to value indicated on tire gauge for rear RH tire
AIR PRESS RL	Approximately equal to value indicated on tire gauge for rear LH tire

Is the inspection result normal?

- YES >> Inspection End.
NO >> Repair or replace malfunctioning components.

C1708, C1709, C1710, C1711 TRANSMITTER (NO DATA)

< DTC/CIRCUIT DIAGNOSIS >

C1708, C1709, C1710, C1711 TRANSMITTER (NO DATA)

DTC Logic

INFOID:000000009134859

NOTE:

The Signal Tech II Tool (J-50190) can be used to perform the following functions. Refer to the Signal Tech II User Guide for additional information.

- Activate and display TPMS transmitter IDs
- Display tire pressure reported by the TPMS transmitter
- Read TPMS DTCs
- Register TPMS transmitter IDs

DTC DETECTION LOGIC

CONSULT Display	DTC Detection Condition	Possible Cause
[NO - DATA] - FL [C1708]	Data signal from the front LH wheel sensor cannot be detected.	<ul style="list-style-type: none">• Driving in area with radio interference.• ID registration incomplete• Tire pressure sensor• Harness or connectors• Remote keyless entry receiver• BCM
[NO - DATA] - FR [C1709]	Data signal from the front RH wheel sensor cannot be detected.	
[NO - DATA] - RR [C1710]	Data signal from the rear RH wheel sensor cannot be detected.	
[NO - DATA] - RL [C1711]	Data signal from the rear LH wheel sensor cannot be detected.	

DTC CONFIRMATION PROCEDURE

1. PERFORM SELF DIAGNOSTIC RESULT

With CONSULT

1. Perform tire pressure sensor ID registration. Refer to [WT-24, "Work Procedure"](#).
2. Drive at a speed of 40 km/h (25 MPH) or more for 3 minutes, and then drive the vehicle at any speed for 10 minutes.

NOTE:

Avoid driving in areas with radio interference.

3. Perform Self Diagnostic Result.

Is DTC C1708, C1709, C1710, or C1711 detected?

- YES >> Proceed to [WT-29, "Diagnosis Procedure"](#).
- NO >> Inspection End.

Diagnosis Procedure

INFOID:000000009134860

NOTE:

The Signal Tech II Tool (J-50190) can be used to perform the following functions. Refer to the Signal Tech II User Guide for additional information.

- Activate and display TPMS transmitter IDs
- Display tire pressure reported by the TPMS transmitter
- Read TPMS DTCs
- Register TPMS transmitter IDs

Regarding Wiring Diagram information, refer to [WT-14, "Wiring Diagram"](#).

1. CHECK TIRE PRESSURE SIGNAL

With CONSULT

1. Select Data Monitor from AIR PRESSURE MONITOR of BCM.
2. Check that the air pressures match the specified value.

C1708, C1709, C1710, C1711 TRANSMITTER (NO DATA)

< DTC/CIRCUIT DIAGNOSIS >

Monitor item	Displayed value
AIR PRESS FL	Approximately equal to specified value. Refer to WT-60, "Tire Air Pressure" .
AIR PRESS FR	
AIR PRESS RR	
AIR PRESS RL	

Are all tire pressures displayed 0 kPa (psi)?

YES >> GO TO 2.

NO >> Replace applicable tire pressure sensor. Refer to [WT-56, "Removal and Installation"](#).

2. CHECK REMOTE KEYLESS ENTRY RECEIVER POWER CIRCUIT

Check voltage between remote keyless entry receiver connector M86 terminal 1 and ground.

Remote keyless entry receiver		Ground	Voltage (Approx.)
Connector	Terminal		
M86	1	—	Battery voltage

Is the inspection result normal?

YES >> GO TO 3.

NO >> Repair or replace harness or connectors.

3. CHECK REMOTE KEYLESS ENTRY RECEIVER SIGNAL

1. Turn ignition switch ON.
2. Check signal between remote keyless entry receiver connector M86 terminal 2 and ground with an oscilloscope.

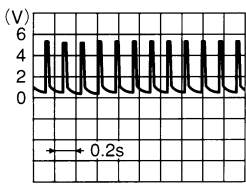
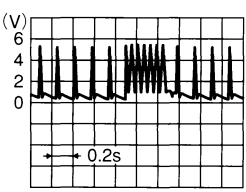
Remote keyless entry receiver		Condition	Voltage (Approx.)
Connector	Terminal		
M86	2	Standby state	
		When receiving the signal from the transmitter	

Is the inspection result normal?

YES >> GO TO 6.

NO >> GO TO 4.

4. CHECK REMOTE KEYLESS ENTRY RECEIVER SIGNAL CIRCUIT

1. Turn ignition switch OFF.
2. Disconnect BCM connector M80 and remote keyless entry receiver connector.
3. Check continuity between BCM connector M80 terminal 119 and remote keyless entry receiver connector M86 terminal 2.

C1708, C1709, C1710, C1711 TRANSMITTER (NO DATA)

< DTC/CIRCUIT DIAGNOSIS >

BCM		Remote keyless entry receiver		Continuity
Connector	Terminal	Connector	Terminal	
M80	119	M86	2	Yes

4. Check continuity between BCM connector M80 terminal 119 and ground.

BCM		Ground	Continuity
Connector	Terminal		
M80	119	—	No

Is the inspection result normal?

YES >> GO TO 5.

NO >> Repair or replace harness or connectors.

5. CHECK REMOTE KEYLESS ENTRY RECEIVER GROUND CIRCUIT

Check continuity between remote keyless entry receiver connector M86 terminal 3 and ground.

Remote keyless entry receiver		Ground	Continuity
Connector	Terminal		
M86	3	—	Yes

Is the inspection result normal?

YES >> Replace the remote keyless entry receiver. Refer to [DLK-313, "Removal and Installation"](#).

NO >> Repair or replace harness or connectors.

6. TIRE PRESSURE SENSOR ID REGISTRATION

Perform tire pressure sensor ID registration. Refer to [WT-24, "Work Procedure"](#).

Can the tire pressure sensor ID registration be completed?

YES >> GO TO 7.

NO >> Replace applicable tire pressure sensor. Refer to [WT-56, "Removal and Installation"](#).

7. RECHECK TIRE PRESSURE SIGNAL

With CONSULT

1. Drive at a speed of 40 km/h (25 MPH) or more for 3 minutes, and then drive the vehicle at any speed for 10 minutes.
2. Select Data Monitor from AIR PRESSURE MONITOR of BCM.
3. Check that the air pressures match the specified value.

Monitor item	Displayed value
AIR PRESS FL	Approximately equal to specified value. Refer to WT-60, "Tire Air Pressure" .
AIR PRESS FR	
AIR PRESS RR	
AIR PRESS RL	

Does Data Monitor display specified value without turning tire pressure warning lamp ON?

YES >> Inspection End.

NO >> Replace BCM. Refer to [BCS-79, "Removal and Installation"](#).

C1712, C1713, C1714, C1715 TRANSMITTER (CHECKSUM)

< DTC/CIRCUIT DIAGNOSIS >

C1712, C1713, C1714, C1715 TRANSMITTER (CHECKSUM)

DTC Logic

INFOID:000000009134861

NOTE:

The Signal Tech II Tool (J-50190) can be used to perform the following functions. Refer to the Signal Tech II User Guide for additional information.

- Activate and display TPMS transmitter IDs
- Display tire pressure reported by the TPMS transmitter
- Read TPMS DTCs
- Register TPMS transmitter IDs

DTC DETECTION LOGIC

CONSULT Display	DTC Detection Condition	Possible Cause
[CHECKSUM - ERR] - FL [C1712]	Checksum data signal from front LH wheel sensor is malfunctioning.	<ul style="list-style-type: none">• ID registration incomplete• Tire pressure sensor• BCM
[CHECKSUM - ERR] - FR [C1713]	Checksum data signal from front RH wheel sensor is malfunctioning.	
[CHECKSUM - ERR] - RR [C1714]	Checksum data signal from rear RH wheel sensor is malfunctioning.	
[CHECKSUM - ERR] - RL [C1715]	Checksum data signal from rear LH wheel sensor is malfunctioning.	

DTC CONFIRMATION PROCEDURE

1. PERFORM SELF DIAGNOSTIC RESULT

With CONSULT

1. Drive at a speed of 40 km/h (25 MPH) or more for 3 minutes, and then drive the vehicle at any speed for 10 minutes.
2. Perform Self Diagnostic Result.

Is DTC C1712, C1713, C1714, or C1715 detected?

- YES >> Proceed to [WT-32. "Diagnosis Procedure"](#).
NO >> Inspection End.

Diagnosis Procedure

INFOID:000000009134862

NOTE:

The Signal Tech II Tool (J-50190) can be used to perform the following functions. Refer to the Signal Tech II User Guide for additional information.

- Activate and display TPMS transmitter IDs
- Display tire pressure reported by the TPMS transmitter
- Read TPMS DTCs
- Register TPMS transmitter IDs

1. TIRE PRESSURE SENSOR ID REGISTRATION

Perform tire pressure sensor ID registration. Refer to [WT-24. "Work Procedure"](#).

Can the tire pressure sensor ID registration be completed?

- YES >> GO TO 2.
NO >> Replace applicable tire pressure sensor. Refer to [WT-56. "Removal and Installation"](#).

2. PERFORM SELF DIAGNOSTIC RESULT

With CONSULT

1. Drive at a speed of 40 km/h (25 MPH) or more for 3 minutes, and then drive the vehicle at any speed for 10 minutes.
2. Perform Self Diagnostic Result.

Is DTC C1712, C1713, C1714, or C1715 detected?

C1712, C1713, C1714, C1715 TRANSMITTER (CHECKSUM)

< DTC/CIRCUIT DIAGNOSIS >

YES >> Replace BCM. Refer to [BCS-79. "Removal and Installation"](#).

NO >> Inspection End.

A

B

C

D

WT

F

G

H

I

J

K

L

M

N

O

P

C1716, C1717, C1718, C1719 TRANSMITTER (PRESSURE DATA)

< DTC/CIRCUIT DIAGNOSIS >

C1716, C1717, C1718, C1719 TRANSMITTER (PRESSURE DATA)

DTC Logic

INFOID:000000009134863

NOTE:

The Signal Tech II Tool (J-50190) can be used to perform the following functions. Refer to the Signal Tech II User Guide for additional information.

- Activate and display TPMS transmitter IDs
- Display tire pressure reported by the TPMS transmitter
- Read TPMS DTCs
- Register TPMS transmitter IDs

DTC DETECTION LOGIC

CONSULT Display	DTC Detection Condition	Possible Cause
[PRESSDATA ERR] FL [C1716]	Malfunction in the tire pressure data from the front LH wheel tire pressure sensor.	<ul style="list-style-type: none">• Excessive tire pressure• ID registration incomplete• Tire pressure sensor• BCM
[PRESSDATA ERR] FR [C1717]	Malfunction in the tire pressure data from the front RH wheel tire pressure sensor.	
[PRESSDATA ERR] RR [C1718]	Malfunction in the tire pressure data from the rear RH wheel tire pressure sensor.	
[PRESSDATA ERR] RL [C1719]	Malfunction in the tire pressure data from the rear LH wheel tire pressure sensor.	

DTC CONFIRMATION PROCEDURE

1. PERFORM SELF DIAGNOSTIC RESULT

Ⓟ With CONSULT

1. Check tire pressure for all wheels and adjust to the specified value. Refer to [WT-60, "Tire Air Pressure"](#).
2. Drive at a speed of 40 km/h (25 MPH) or more for 3 minutes, and then drive the vehicle at any speed for 10 minutes.
3. Perform Self Diagnostic Result.

Is DTC C1716, C1717, C1718, or C1719 detected?

- YES >> Proceed to [WT-34, "Diagnosis Procedure"](#).
NO >> Inspection End.

Diagnosis Procedure

INFOID:000000009134864

NOTE:

The Signal Tech II Tool (J-50190) can be used to perform the following functions. Refer to the Signal Tech II User Guide for additional information.

- Activate and display TPMS transmitter IDs
- Display tire pressure reported by the TPMS transmitter
- Read TPMS DTCs
- Register TPMS transmitter IDs

1. TIRE PRESSURE SENSOR ID REGISTRATION

Perform tire pressure sensor ID registration. Refer to [WT-24, "Work Procedure"](#).

Can the tire pressure sensor ID registration be completed?

- YES >> GO TO 2.
NO >> Replace applicable tire pressure sensor. Refer to [WT-56, "Removal and Installation"](#).

2. CHECK TIRE PRESSURE SIGNAL

Ⓟ With CONSULT

1. Adjust tire pressure for all wheels to the specified value. Refer to [WT-60, "Tire Air Pressure"](#).
2. Select Data Monitor from AIR PRESSURE MONITOR of BCM.
3. Check that the air pressures match the specified value.

C1716, C1717, C1718, C1719 TRANSMITTER (PRESSURE DATA)

< DTC/CIRCUIT DIAGNOSIS >

Monitor item	Displayed value	A
AIR PRESS FL	Approximately equal to specified value. Refer to WT-60, "Tire Air Pressure" .	
AIR PRESS FR		B
AIR PRESS RR		
AIR PRESS RL		

Is the inspection result normal?

YES >> Inspection End.

NO >> Replace BCM. Refer to [BCS-79, "Removal and Installation"](#).

C

D

WT

F

G

H

I

J

K

L

M

N

O

P

C1720, C1721, C1722, C1723 TRANSMITTER

< DTC/CIRCUIT DIAGNOSIS >

C1720, C1721, C1722, C1723 TRANSMITTER

DTC Logic

INFOID:000000009134865

NOTE:

The Signal Tech II Tool (J-50190) can be used to perform the following functions. Refer to the Signal Tech II User Guide for additional information.

- Activate and display TPMS transmitter IDs
- Display tire pressure reported by the TPMS transmitter
- Read TPMS DTCs
- Register TPMS transmitter IDs

DTC DETECTION LOGIC

CONSULT Display	DTC Detection Condition	Possible Cause
[CODE - ERR] - FL [C1720]	Function code data from front LH wheel sensor is malfunctioning.	<ul style="list-style-type: none">• ID registration incomplete• Tire pressure sensor• BCM
[CODE - ERR] - FR [C1721]	Function code data from front RH wheel sensor is malfunctioning.	
[CODE - ERR] - RR [C1722]	Function code data from rear RH wheel sensor is malfunctioning.	
[CODE - ERR] - RL [C1723]	Function code data from rear LH wheel sensor is malfunctioning.	

DTC CONFIRMATION PROCEDURE

1. PERFORM SELF DIAGNOSTIC RESULT

With CONSULT

1. Drive at a speed of 40 km/h (25 MPH) or more for 3 minutes, and then drive the vehicle at any speed for 10 minutes.
2. Perform Self Diagnostic Result.

Is DTC C1720, C1721, C1722, or C1723 detected?

- YES >> Proceed to [WT-36, "Diagnosis Procedure"](#).
NO >> Inspection End.

Diagnosis Procedure

INFOID:000000009134866

NOTE:

The Signal Tech II Tool (J-50190) can be used to perform the following functions. Refer to the Signal Tech II User Guide for additional information.

- Activate and display TPMS transmitter IDs
- Display tire pressure reported by the TPMS transmitter
- Read TPMS DTCs
- Register TPMS transmitter IDs

1. TIRE PRESSURE SENSOR ID REGISTRATION

Perform tire pressure sensor ID registration. Refer to [WT-24, "Work Procedure"](#).

Can the tire pressure sensor ID registration be completed?

- YES >> GO TO 2.
NO >> Replace applicable tire pressure sensor. Refer to [WT-56, "Removal and Installation"](#).

2. PERFORM SELF DIAGNOSTIC RESULT

With CONSULT

1. Drive at a speed of 40 km/h (25 MPH) or more for 3 minutes, and then drive the vehicle at any speed for 10 minutes.
2. Perform Self Diagnostic Result.

Is DTC C1720, C1721, C1722, or C1723 detected?

C1720, C1721, C1722, C1723 TRANSMITTER

< DTC/CIRCUIT DIAGNOSIS >

YES >> Replace BCM. Refer to [BCS-79. "Removal and Installation"](#).
NO >> Inspection End.

A

B

C

D

WT

F

G

H

I

J

K

L

M

N

O

P

C1724, C1725, C1726, C1727 TRANSMITTER (BATT VOLT)

< DTC/CIRCUIT DIAGNOSIS >

C1724, C1725, C1726, C1727 TRANSMITTER (BATT VOLT)

DTC Logic

INFOID:000000009134867

NOTE:

The Signal Tech II Tool (J-50190) can be used to perform the following functions. Refer to the Signal Tech II User Guide for additional information.

- Activate and display TPMS transmitter IDs
- Display tire pressure reported by the TPMS transmitter
- Read TPMS DTCs
- Register TPMS transmitter IDs

DTC DETECTION LOGIC

CONSULT Display	DTC Detection Condition	Possible Cause
[BATT - VOLT - LOW] - FL [C1724]	Battery voltage of front LH wheel sensor drops.	• Tire pressure sensor • BCM
[BATT - VOLT - LOW] - FR [C1725]	Battery voltage of front RH wheel sensor drops.	
[BATT - VOLT - LOW] - RR [C1726]	Battery voltage of rear RH wheel sensor drops.	
[BATT - VOLT - LOW] - RL [C1727]	Battery voltage of rear LH wheel sensor drops.	

DTC CONFIRMATION PROCEDURE

1. PERFORM SELF DIAGNOSTIC RESULT

With CONSULT

1. Drive at a speed of 40 km/h (25 MPH) or more for 3 minutes, and then drive the vehicle at any speed for 10 minutes.
2. Perform Self Diagnostic Result.

Is DTC C1724, C1725, C1726, or C1727 detected?

- YES >> Proceed to [WT-38, "Diagnosis Procedure"](#).
NO >> Inspection End.

Diagnosis Procedure

INFOID:000000009134868

NOTE:

The Signal Tech II Tool (J-50190) can be used to perform the following functions. Refer to the Signal Tech II User Guide for additional information.

- Activate and display TPMS transmitter IDs
- Display tire pressure reported by the TPMS transmitter
- Read TPMS DTCs
- Register TPMS transmitter IDs

1. TIRE PRESSURE SENSOR ID REGISTRATION

Perform tire pressure sensor ID registration. Refer to [WT-24, "Work Procedure"](#).

Can the tire pressure sensor ID registration be completed?

- YES >> GO TO 2.
NO >> Replace applicable tire pressure sensor. Refer to [WT-56, "Removal and Installation"](#).

2. PERFORM SELF DIAGNOSTIC RESULT

With CONSULT

1. Drive at a speed of 40 km/h (25 MPH) or more for 3 minutes, and then drive the vehicle at any speed for 10 minutes.
2. Perform Self Diagnostic Result.

Is DTC C1724, C1725, C1726, or C1727 detected?

C1724, C1725, C1726, C1727 TRANSMITTER (BATT VOLT)

< DTC/CIRCUIT DIAGNOSIS >

YES >> Replace BCM. Refer to [BCS-79. "Removal and Installation"](#).

NO >> Inspection End.

A

B

C

D

WT

F

G

H

I

J

K

L

M

N

O

P

C1729 VEHICLE SPEED SIGNAL

< DTC/CIRCUIT DIAGNOSIS >

C1729 VEHICLE SPEED SIGNAL

DTC Logic

INFOID:000000009134869

NOTE:

The Signal Tech II Tool (J-50190) can be used to perform the following functions. Refer to the Signal Tech II User Guide for additional information.

- Activate and display TPMS transmitter IDs
- Display tire pressure reported by the TPMS transmitter
- Read TPMS DTCs
- Register TPMS transmitter IDs

DTC DETECTION LOGIC

CONSULT Display	DTC Detection Condition	Possible Cause
VHCL SPEED SIG ERR [C1729]	Vehicle speed signal not detected.	<ul style="list-style-type: none">• CAN communication• BCM• Combination meter

DTC CONFIRMATION PROCEDURE

1. PERFORM SELF DIAGNOSTIC RESULT

With CONSULT

1. Drive at a speed of 40 km/h (25 MPH) or more for 3 minutes, and then drive the vehicle at any speed for 10 minutes.
2. Perform Self Diagnostic Result.

Is DTC C1729 detected?

YES >> Proceed to [WT-40, "Diagnosis Procedure"](#).

NO >> Inspection End.

Diagnosis Procedure

INFOID:000000009134870

NOTE:

The Signal Tech II Tool (J-50190) can be used to perform the following functions. Refer to the Signal Tech II User Guide for additional information.

- Activate and display TPMS transmitter IDs
- Display tire pressure reported by the TPMS transmitter
- Read TPMS DTCs
- Register TPMS transmitter IDs

1. PERFORM SELF DIAGNOSTIC RESULT FOR COMBINATION METER

With CONSULT

Perform Self Diagnostic Result for METER M&A. Refer to [MWI-17, "CONSULT Function \(METER/M&A\)"](#).

Are any DTCs detected?

YES >> Refer to [MWI-26, "DTC Index"](#).

NO >> Replace the BCM. Refer to [BCS-79, "Removal and Installation"](#).

C1730, C1731, C1732, C1733 FLAT TIRE

< DTC/CIRCUIT DIAGNOSIS >

C1730, C1731, C1732, C1733 FLAT TIRE

DTC Logic

INFOID:000000009134871

NOTE:

The Signal Tech II Tool (J-50190) can be used to perform the following functions. Refer to the Signal Tech II User Guide for additional information.

- Activate and display TPMS transmitter IDs
- Display tire pressure reported by the TPMS transmitter
- Read TPMS DTCs
- Register TPMS transmitter IDs

DTC DETECTION LOGIC

CONSULT Display	DTC Detection Condition	Possible Cause
FLAT TIRE FL [C1730]	Front LH tire pressure is 70 kPa (0.7 kg/cm ² , 10 psi) or less.	• Low tire pressure • Tire pressure sensor
FLAT TIRE FR [C1731]	Front RH tire pressure is 70 kPa (0.7 kg/cm ² , 10 psi) or less.	
FLAT TIRE RR [C1732]	Rear RH tire pressure is 70 kPa (0.7 kg/cm ² , 10 psi) or less.	
FLAT TIRE RL [C1733]	Rear LH tire pressure is 70 kPa (0.7 kg/cm ² , 10 psi) or less.	

DTC CONFIRMATION PROCEDURE

1. PERFORM SELF DIAGNOSTIC RESULT

With CONSULT

1. Drive at a speed of 40 km/h (25 MPH) or more for 3 minutes, and then drive the vehicle at any speed for 10 minutes.
2. Perform Self Diagnostic Result.

Is DTC C1730, C1731, C1732, or C1733 detected?

- YES >> Proceed to [WT-41, "Diagnosis Procedure"](#).
NO >> Inspection End.

Diagnosis Procedure

INFOID:000000009134872

NOTE:

The Signal Tech II Tool (J-50190) can be used to perform the following functions. Refer to the Signal Tech II User Guide for additional information.

- Activate and display TPMS transmitter IDs
- Display tire pressure reported by the TPMS transmitter
- Read TPMS DTCs
- Register TPMS transmitter IDs

1. TIRE PRESSURE SENSOR ID REGISTRATION

Perform tire pressure sensor ID registration. Refer to [WT-24, "Work Procedure"](#).

Can the tire pressure sensor ID registration be completed?

- YES >> GO TO 2.
NO >> Replace applicable tire pressure sensor. Refer to [WT-56, "Removal and Installation"](#).

2. CHECK TIRE PRESSURE

Check the air pressure of all wheels. Refer to [WT-60, "Tire Air Pressure"](#).

Is the inspection result normal?

- YES >> Perform DTC CONFIRMATION PROCEDURE again. Refer to [WT-41, "DTC Logic"](#).
NO >> GO TO 3.

C1730, C1731, C1732, C1733 FLAT TIRE

< DTC/CIRCUIT DIAGNOSIS >

3. CHECK TIRE PRESSURE SIGNAL

With CONSULT

1. Adjust tire pressure for all wheels to the specified value. Refer to [WT-60. "Tire Air Pressure"](#).
2. Select Data Monitor from AIR PRESSURE MONITOR of BCM.
3. Check that the air pressures match the specified value.

Monitor item	Displayed value
AIR PRESS FL	Approximately equal to value indicated on tire gauge for front LH tire
AIR PRESS FR	Approximately equal to value indicated on tire gauge for front RH tire
AIR PRESS RR	Approximately equal to value indicated on tire gauge for rear RH tire
AIR PRESS RL	Approximately equal to value indicated on tire gauge for rear LH tire

Is the inspection result normal?

- YES >> Inspection End.
NO >> Repair or replace malfunctioning components.

C1734 BCM

< DTC/CIRCUIT DIAGNOSIS >

C1734 BCM

DTC Logic

INFOID:000000009134873

NOTE:

The Signal Tech II Tool (J-50190) can be used to perform the following functions. Refer to the Signal Tech II User Guide for additional information.

- Activate and display TPMS transmitter IDs
- Display tire pressure reported by the TPMS transmitter
- Read TPMS DTCs
- Register TPMS transmitter IDs

DTC DETECTION LOGIC

CONSULT Display	DTC Detection Condition	Possible Cause
CONTROL UNIT [C1734]	TPMS malfunction in BCM.	BCM

DTC CONFIRMATION PROCEDURE

1.PERFORM SELF DIAGNOSTIC RESULT

With CONSULT

Perform Self Diagnostic Result.

Is DTC C1734 detected?

- YES >> Proceed to [WT-43, "Diagnosis Procedure"](#).
- NO >> Inspection End.

Diagnosis Procedure

INFOID:000000009134874

NOTE:

The Signal Tech II Tool (J-50190) can be used to perform the following functions. Refer to the Signal Tech II User Guide for additional information.

- Activate and display TPMS transmitter IDs
- Display tire pressure reported by the TPMS transmitter
- Read TPMS DTCs
- Register TPMS transmitter IDs

Regarding Wiring Diagram information, refer to [WT-14, "Wiring Diagram"](#).

1.CHECK BCM HARNESS CONNECTORS

Check BCM harness connectors for damage or loose connections.

Is the inspection result normal?

- YES >> Repair or replace connectors.
- NO >> GO TO 2.

2.CHECK BCM POWER SUPPLY AND GROUND

Check BCM power supply and ground. Refer to [BCS-73, "Diagnosis Procedure"](#).

Is the inspection result normal?

- YES >> GO TO 3.
- NO >> Repair or replace harness or connectors.

3.CHECK REMOTE KEYLESS ENTRY RECEIVER POWER CIRCUIT

Check voltage between remote keyless entry receiver connector M86 terminal 1 and ground.

C1734 BCM

< DTC/CIRCUIT DIAGNOSIS >

Remote keyless entry receiver		Ground	Voltage (Approx.)
Connector	Terminal		
M86	1	—	Battery voltage

Is the inspection result normal?

YES >> GO TO 4.

NO >> Repair or replace harness or connectors.

4. CHECK REMOTE KEYLESS ENTRY RECEIVER SIGNAL CIRCUIT

1. Turn ignition switch OFF.
2. Disconnect BCM connector M80 and remote keyless entry receiver connector.
3. Check continuity between BCM connector M80 terminal 119 and remote keyless entry receiver connector M86 terminal 2.

BCM		Remote keyless entry receiver		Continuity
Connector	Terminal	Connector	Terminal	
M80	119	M86	2	Yes

4. Check continuity between BCM connector M80 terminal 119 and ground.

BCM		Ground	Continuity
Connector	Terminal		
M80	119	—	No

Is the inspection result normal?

YES >> GO TO 5.

NO >> Repair or replace harness or connectors.

5. CHECK REMOTE KEYLESS ENTRY RECEIVER GROUND CIRCUIT

Check continuity between remote keyless entry receiver connector M86 terminal 3 and ground.

Remote keyless entry receiver		Ground	Continuity
Connector	Terminal		
M86	3	—	Yes

Is the inspection result normal?

YES >> GO TO 6.

NO >> Repair or replace harness or connectors.

6. CHECK BCM INPUT/OUTPUT SIGNALS

Check BCM input/output signals. Refer to [BCS-29, "Reference Value"](#).

Is the inspection result normal?

YES >> Inspection End.

NO >> Replace BCM. Refer to [BCS-79, "Removal and Installation"](#).

C1735 IGNITION SIGNAL

< DTC/CIRCUIT DIAGNOSIS >

C1735 IGNITION SIGNAL

DTC Logic

INFOID:000000009134875

NOTE:

The Signal Tech II Tool (J-50190) can be used to perform the following functions. Refer to the Signal Tech II User Guide for additional information.

- Activate and display TPMS transmitter IDs
- Display tire pressure reported by the TPMS transmitter
- Read TPMS DTCs
- Register TPMS transmitter IDs

DTC DETECTION LOGIC

CONSULT Display	DTC Detection Condition	Possible Cause
IGNITION SIGNAL LINE - BCM/TPMS [C1735]	BCM has detected a mismatch between IGN ON signals.	BCM

DTC CONFIRMATION PROCEDURE

1.PERFORM SELF DIAGNOSTIC RESULT

With CONSULT

Perform Self Diagnostic Result.

Is DTC C1735 detected?

- YES >> Proceed to [WT-45, "Diagnosis Procedure"](#).
NO >> Inspection End.

Diagnosis Procedure

INFOID:000000009134876

NOTE:

The Signal Tech II Tool (J-50190) can be used to perform the following functions. Refer to the Signal Tech II User Guide for additional information.

- Activate and display TPMS transmitter IDs
- Display tire pressure reported by the TPMS transmitter
- Read TPMS DTCs
- Register TPMS transmitter IDs

1.CHECK CAN IGNITION SIGNAL

With CONSULT

1. Select Data Monitor from INTELLIGENT KEY of BCM.
2. Check IGN RLY1-F/B value.

Monitor item	Displayed value
IGN RLY1 F/B	On with ignition in ON position

Is the inspection result normal?

- YES >> GO TO 2.
NO >> Check CAN system. Refer to [LAN-26, "Trouble Diagnosis Flow Chart"](#).

2.CHECK BCM POWER SUPPLY AND GROUND

Check BCM power supply and ground. Refer to [BCS-73, "Diagnosis Procedure"](#).

Is the inspection result normal?

- YES >> GO TO 3.
NO >> Repair or replace harness or connectors.

3.DRIVE VEHICLE

Clear DTC and test drive vehicle to check for low tire pressure warning lamp.

Does the vehicle operate without any low tire pressure warning lamp?

C1735 IGNITION SIGNAL

< DTC/CIRCUIT DIAGNOSIS >

- YES >> Inspection End.
- NO >> Replace BCM. Refer to [BCS-79, "Removal and Installation"](#).

TPMS

< SYMPTOM DIAGNOSIS >

SYMPTOM DIAGNOSIS

TPMS

Symptom Table

INFOID:000000009134877

Symptom	Reference
Low tire pressure warning lamp does not come on when ignition switch is turned ON.	WT-48
Low tire pressure warning lamp stays on when ignition switch is turned ON.	WT-49
Tire inflation indicator does not activate.	WT-50

A

B

C

D

WT

F

G

H

I

J

K

L

M

N

O

P

LOW TIRE PRESSURE WARNING LAMP DOES NOT TURN ON

< SYMPTOM DIAGNOSIS >

LOW TIRE PRESSURE WARNING LAMP DOES NOT TURN ON

Low Tire Pressure Warning Lamp Does Not Come On When Ignition Switch Is Turned On

INFOID:000000009134878

NOTE:

The Signal Tech II Tool (J-50190) can be used to perform the following functions. Refer to the Signal Tech II User Guide for additional information.

- Activate and display TPMS transmitter IDs
- Display tire pressure reported by the TPMS transmitter
- Read TPMS DTCs
- Register TPMS transmitter IDs

1. PERFORM SELF DIAGNOSTIC RESULT

Ⓟ With CONSULT

Perform Self Diagnostic Result.

Is DTC U1000 detected?

- YES >> Refer to [LAN-26, "Trouble Diagnosis Flow Chart"](#).
- NO >> GO TO 2

2. CHECK COMBINATION METER

Check combination meter operation. Refer to [MWI-17, "CONSULT Function \(METER/M&A\)"](#).

Is the inspection result normal?

- YES >> GO TO 3
- NO >> Replace combination meter. Refer to [MWI-95, "Removal and Installation"](#).

3. CHECK LOW TIRE PRESSURE WARNING LAMP

Disconnect BCM harness connector.

Does the low tire pressure warning lamp activate?

- YES >> Replace BCM. Refer to [BCS-79, "Removal and Installation"](#).
- NO >> Check combination meter operation.

LOW TIRE PRESSURE WARNING LAMP STAYS ON

< SYMPTOM DIAGNOSIS >

LOW TIRE PRESSURE WARNING LAMP STAYS ON

Low Tire Pressure Warning Lamp Stays On When Ignition Switch Is Turned On

INFOID:000000009134879

1. CHECK BCM CONNECTORS

1. Turn ignition switch OFF.
2. Disconnect BCM connectors.
3. Check terminals for damage or loose connections.

Is the inspection result normal?

- YES >> GO TO 2
NO >> Repair or replace damaged connectors.

2. BCM POWER SUPPLY AND GROUND CIRCUITS

Check BCM power supply and ground circuits. Refer to [BCS-73, "Diagnosis Procedure"](#).

Is the inspection result normal?

- YES >> Replace BCM. Refer to [BCS-79, "Removal and Installation"](#).
NO >> Repair BCM circuits.

A
B
C
D
WT
F
G
H
I
J
K
L
M
N
O
P

TIRE INFLATION INDICATOR DOES NOT ACTIVATE

< SYMPTOM DIAGNOSIS >

TIRE INFLATION INDICATOR DOES NOT ACTIVATE

Description

INFOID:000000009134880

The tire inflation indicator does not function while inflating a tire when the select lever position is in P-range with the ignition switch ON. Refer to [WT-8, "Tire Inflation Indicator Function"](#).

Diagnosis Procedure

INFOID:000000009134881

1. LOCATION CHANGE

Move the vehicle to another area and repeat the procedure of the tire inflation indicator function. Refer to [WT-8, "Tire Inflation Indicator Function"](#).

Is the function normal?

- YES >> Inspection End.
- NO >> GO TO 2.

2. PERFORM SELF DIAGNOSTIC RESULT

Ⓢ With CONSULT

Perform Self Diagnostic Result.

Are any DTCs detected?

- YES >> Refer to [BCS-51, "DTC Index"](#).
- NO >> GO TO 3.

3. CHECK HAZARD WARNING LAMP OPERATION

Check hazard warning lamp operation with hazard switch.

Do the hazard warning lamps operate?

- YES >> GO TO 4.
- NO >> Refer to [DLK-200, "Diagnosis Procedure"](#).

4. PERFORM SELF DIAGNOSTIC RESULT FOR TCM

Ⓢ With CONSULT

Perform Self Diagnostic Result for TRANSMISSION.

Are any DTCs detected?

- YES >> Refer to [TM-44, "CONSULT Function"](#).
- NO >> GO TO 5.

5. CHECK HORN OPERATION

Check horn operation. Refer to [SEC-141, "Diagnosis Procedure"](#).

Is the inspection result normal?

- YES >> GO TO 6.
- NO >> Repair or replace malfunctioning components.

6. PERFORM SELF DIAGNOSTIC RESULT

Ⓢ With CONSULT

1. Drive at a speed of 40 km/h (25 MPH) or more for 3 minutes, and then drive the vehicle at any speed for 10 minutes.
2. Perform Self Diagnostic Result.

Are any DTCs detected?

- YES >> Refer to [BCS-51, "DTC Index"](#).
- NO >> Replace BCM. Refer to [BCS-79, "Removal and Installation"](#).

NOISE, VIBRATION AND HARSHNESS (NVH) TROUBLESHOOTING

< SYMPTOM DIAGNOSIS >

NOISE, VIBRATION AND HARSHNESS (NVH) TROUBLESHOOTING

NVH Troubleshooting Chart

INFOID:000000009134882

Use the chart below to find the cause of the symptom. If necessary, repair or replace these parts.

Symptom		Possible cause and SUSPECTED PARTS	Reference page																
			Improper installation, looseness	Out-of-round	Imbalance	Incorrect tire pressure	Uneven tire wear	Deformation or damage	Non-uniformity	Incorrect tire size	PROPELLER SHAFT	DIFFERENTIAL	FRONT AXLE AND FRONT SUSPENSION	REAR AXLE AND REAR SUSPENSION	TIRE	ROAD WHEELS	DRIVE SHAFT	BRAKE	STEERING
TIRE	Noise		x	x	x	x	x	x	x		x	x	x	x		x	x	x	x
	Shake		x	x	x	x	x	x		x	x		x	x		x	x	x	x
	Vibration					x				x	x		x	x					x
	Shimmy		x	x	x	x	x	x	x				x	x		x		x	x
	Shudder		x	x	x	x	x	x		x			x	x		x		x	x
	Poor quality ride or handling		x	x	x	x	x	x		x			x		x				
ROAD WHEEL	Noise		x	x	x			x			x	x	x	x		x	x	x	x
	Shake		x	x	x			x			x		x	x		x	x	x	x
	Shimmy, Shudder		x	x	x			x					x	x			x		x
	Poor quality ride or handling		x	x	x			x					x	x					

x: Applicable

A
B
C
D
E
F
G
H
I
J
K
L
M
N
O
P

WT

WHEEL

< PERIODIC MAINTENANCE >

PERIODIC MAINTENANCE

WHEEL

Inspection

INFOID:000000009134883

1. Check tires for wear and improper inflation.
2. Check wheels for deformation, cracks and other damage. If deformed, remove wheel and check wheel runout.
3. Remove tire from wheel and mount wheel on a tire balance machine.

CAUTION:

DO NOT use center hole cone-type clamping machines to hold the wheel assembly during tire removal/installation or balancing or damage to the wheel paint, cladding or chrome may result. Use only rim-type or universal lug-type clamping machines to hold the wheel assembly during servicing.

- a. Set dial indicator as shown.
- b. Check runout, if the lateral runout (A) or radial runout (B) exceeds the limit, replace wheel.

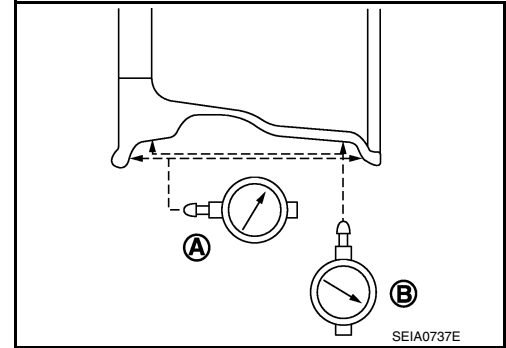

Lateral runout (A)

Refer to [WT-60, "Road Wheel"](#)

Radial runout (B)

Refer to [WT-60, "Road Wheel"](#)

WHEEL AND TIRE ASSEMBLY

< PERIODIC MAINTENANCE >

WHEEL AND TIRE ASSEMBLY

Adjustment

INFOID:000000009134884

BALANCING WHEELS (ADHESIVE WEIGHT TYPE)

Preparation Before Adjustment

Remove inner and outer balance weights from the road wheel. Using releasing agent, remove double-faced adhesive tape from the road wheel.

CAUTION:

- Be careful not to scratch the road wheel during removal.
- After removing double-faced adhesive tape, wipe clean all traces of releasing agent from the road wheel.

Wheel Balance Adjustment

CAUTION:

- DO NOT use center hole cone-type clamping machines to hold the wheel assembly during tire removal/installation or balancing or damage to the wheel paint, cladding or chrome may result. Use only rim-type or universal lug-type clamping machines to hold the wheel assembly during servicing.
- If a balancer machine has an adhesive weight mode setting, select the adhesive weight mode setting and skip Step 2 below. If a balancer machine only has the clip-on (rim flange) weight mode setting, follow Step 2 to calculate the correct size adhesive weight.

1. Set road wheel on balancer machine using the center hole as a guide. Start the balancer machine.
2. For balancer machines that only have a clip-on (rim flange) weight mode setting, follow this step to calculate the correct size adhesive weight to use. When inner and outer imbalance values are shown on the balancer machine indicator, multiply outer imbalance value by 5/3 (1.67) to determine balance weight that should be used. Select the outer balance weight with a value closest to the calculated value above and install in to the designated outer position of or at the designated angle in relation to the road wheel.

- a. Indicated imbalance value $\times 5/3$ (1.67) = balance weight to be installed

Calculation example:

$23 \text{ g (0.81 oz)} \times 5/3 (1.67) = 38.33 \text{ g (1.35 oz)} \Rightarrow 40 \text{ g (1.41 oz)}$
balance weight (closer to calculated balance weight value)

NOTE:

Note that balance weight value must be closer to the calculated balance weight value.

Example:

$37.4 \Rightarrow 35 \text{ g (1.23 oz)}$

$37.5 \Rightarrow 40 \text{ g (1.41 oz)}$

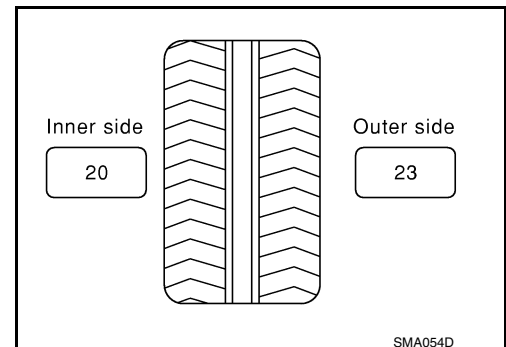

WHEEL AND TIRE ASSEMBLY

< PERIODIC MAINTENANCE >

3. Install balance weight in the position shown.

CAUTION:

- Do not install the inner balance weight before installing the outer balance weight.
- Before installing the balance weight, be sure to clean the mating surface of the road wheel.
- When installing balance weight (1) to road wheel, set it into the grooved area (A) on the inner wall of the road wheel as shown so that the balance weight center (B) is aligned with the balancer machine indication position (angle) (C).

CAUTION:

- Always use genuine NISSAN adhesive balance weights.
- Balance weights are non-reusable; always replace with new ones.
- Do not install more than three sheets of balance weights.

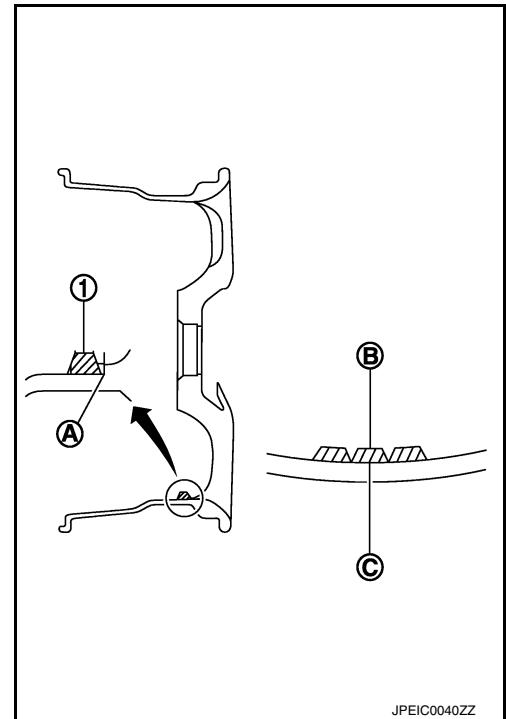

4. If calculated balance weight value exceeds 50 g (1.76 oz), install two balance weight sheets in line with each other as shown.

CAUTION:

Do not install one balance weight sheet on top of another.

5. Start balancer machine again.

6. Install balance weight on inner side of road wheel in the balancer machine indication position (angle).

CAUTION:

Do not install more than two balance weights.

7. Start balancer machine. Make sure that inner and outer residual imbalance values are 5 g (0.17 oz) each or below.

8. If either residual imbalance value exceeds 5 g (0.17 oz), repeat installation procedures.

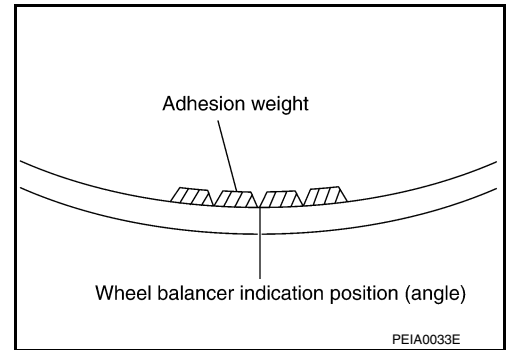

Wheel balance	Dynamic (At flange)	Static (At flange)
Maximum allowable imbalance	Refer to WT-60, "Road Wheel" .	

TIRE ROTATION

- Follow the maintenance schedule for tire rotation service intervals. Refer to [MA-9, "FOR USA AND CANADA : Introduction of Periodic Maintenance"](#) for NORTH AMERICA, or [MA-12, "FOR MEXICO : Introduction of Periodic Maintenance"](#) for MEXICO.

• When installing the wheel, tighten wheel nuts to the specified torque.

CAUTION:

- Do not include the spare tire when rotating the tires.
- When installing wheels, tighten them diagonally by dividing the work two to three times in order to prevent the wheels from developing any distortion.
- Be careful not to tighten wheel nut at torque exceeding the criteria for preventing strain of disc rotor.
- Use NISSAN genuine wheel nuts for aluminum wheels.

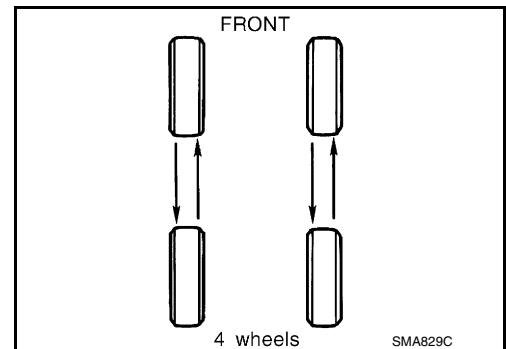

Wheel nut tightening torque : 113 N·m (12 kg·m, 83 ft·lb)

WHEEL AND TIRE ASSEMBLY

< PERIODIC MAINTENANCE >

- Perform the ID registration after tire rotation. Refer to [WT-24, "Description"](#).

A

B

C

D

WT

F

G

H

I

J

K

L

M

N

O

P

TIRE PRESSURE SENSOR

< REMOVAL AND INSTALLATION >

REMOVAL AND INSTALLATION

TIRE PRESSURE SENSOR

Exploded View

INFOID:000000009134885

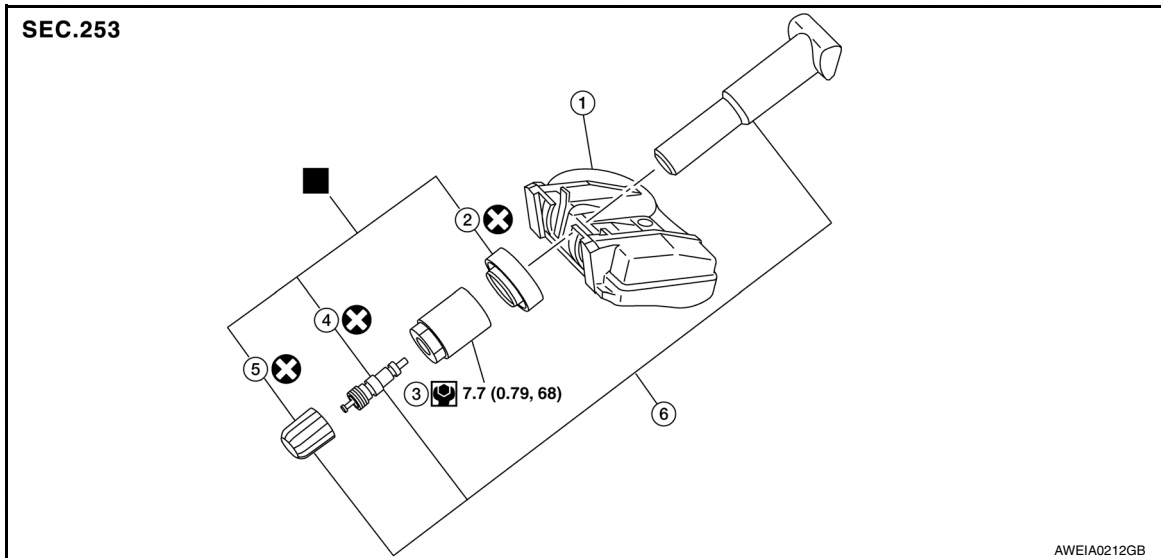

- | | | |
|---------------------------------------|--------------|------------------------|
| 1. Transmitter (tire pressure sensor) | 2. O-ring | 3. Valve stem nut |
| 4. Valve core | 5. Valve cap | 6. Valve stem assembly |
- : Parts that are replaced as a set when the tire is replaced.

Removal and Installation

INFOID:000000009134886

REMOVAL

1. Remove road wheel and tire assembly using power tool.
2. Remove valve cap and valve core to deflate the tire.

NOTE:

If the tire is to be reused, apply a matching mark on the tire in line with the position of the road wheel valve stem assembly for the purpose of road wheel and tire balance adjustment after installation.

3. Remove the valve stem nut and allow transmitter to fall into tire.

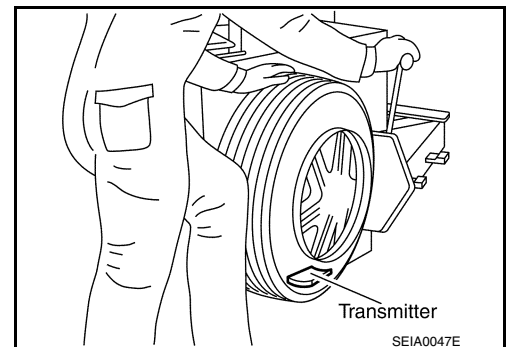

4. Lubricate the tire outside bead well with a suitable non-silicone lubricant, and remove outside of tire from the road wheel. Reach inside the tire and remove the transmitter.

CAUTION:

- Do not use silicone lubricant. Use of silicone lubricant will deteriorate the tire and road wheel.
- Be sure not to damage the road wheel or transmitter.
- Do not allow lubricant to make contact with transmitter.

5. Lubricate the tire inside bead well with a suitable non-silicone lubricant, and remove inside of tire from the road wheel.

TIRE PRESSURE SENSOR

< REMOVAL AND INSTALLATION >

CAUTION:

- Do not use silicone lubricant. Use of silicone lubricant will deteriorate the tire and road wheel.
- Be sure not to damage the road wheel.

6. Remove the valve stem from the transmitter as shown.

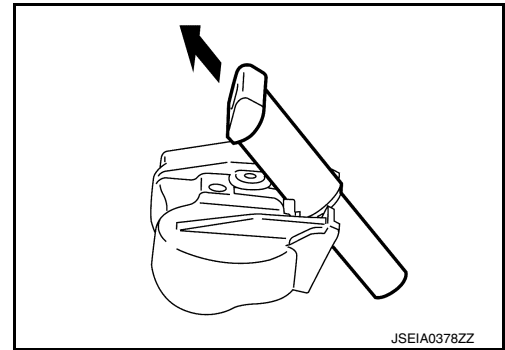

INSTALLATION

1. Apply a suitable non-silicone lubricant to the tire inside bead.

CAUTION:

- Do not use silicone lubricant. Use of silicone lubricant will deteriorate the tire and wheel.

2. Install the tire inside bead (1) onto the road wheel (2) in the position shown.

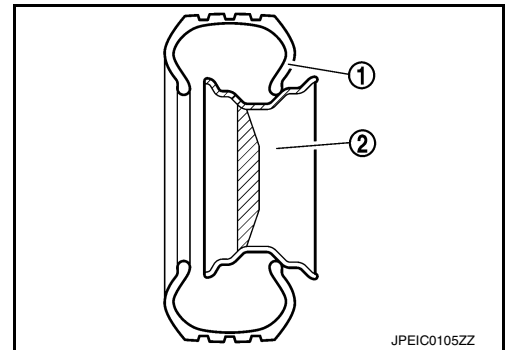

3. Install the valve stem to the transmitter.

4. Install the O-ring to the transmitter.

CAUTION:

- Do not reuse O-ring
- Insert O-ring to the base of the transmitter.
- The base of the valve stem (A) must be positioned in the groove of the metal plate as shown.

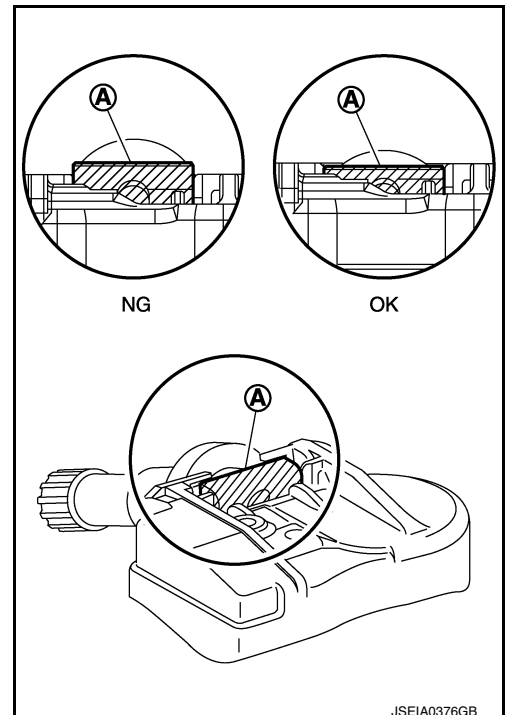

TIRE PRESSURE SENSOR

< REMOVAL AND INSTALLATION >

5. Install transmitter (1) to road wheel while pressing at position (A).

CAUTION:

- Check that O-ring contacts horizontally with road wheel.
- Check that the base of the valve stem is positioned in the groove of the metal plate.

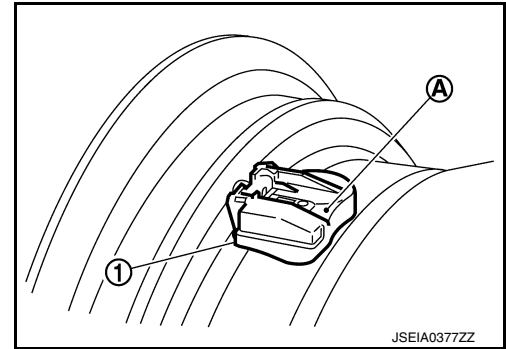

6. Install and tighten the valve stem nut to the specified torque.

Valve stem nut tightening torque : 7.7 N·m (0.79 kg-m, 68 in-lb)

CAUTION:

Do not use power tool for installation.

7. Place wheel on turntable of tire machine. Ensure that transmitter is 270 degrees from mounting/dismounting head.

NOTE:

Do not touch transmitter with mounting head.

8. Apply a suitable non-silicone lubricant to the tire outside bead.

CAUTION:

- Do not use silicone lubricant. Use of silicone lubricant will deteriorate the tire and wheel.
- Do not allow lubricant to make contact with transmitter.

9. Install the tire outside bead onto the road wheel as normal.

NOTE:

If the tire is being reused, align the matching mark applied on the tire with the position of the road wheel valve stem assembly for the purpose of road wheel and tire balance adjustment after installation. Ensure that the tire does not rotate relative to road wheel.

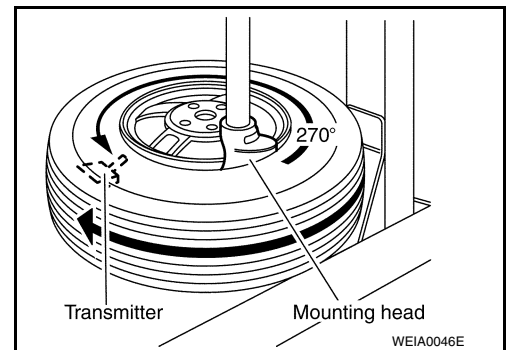

10. Install the valve core and inflate tire.

CAUTION:

Do not reuse valve core.

11. Install the valve cap.

CAUTION:

Do not reuse valve cap.

12. Balance the road wheel and tire assembly. Refer to [WT-53, "Adjustment"](#).

13. Install wheel and tire assembly in appropriate wheel position on vehicle. Refer to [WT-53, "Adjustment"](#).

NOTE:

If replacing the transmitter, then ID registration procedure must be performed. Refer to [WT-24, "Work Procedure"](#).

14. Adjust neutral position of steering angle sensor. Refer to [BRC-60, "Work Procedure"](#).

TIRE PRESSURE RECEIVER

< REMOVAL AND INSTALLATION >

TIRE PRESSURE RECEIVER

Removal and Installation

INFOID:000000009134887

The Tire Pressure Receiver is an integral part of the remote keyless entry receiver. Refer to [SEC-14. "VEHICLE SECURITY SYSTEM : System Description"](#).

A
B
C
D
E
F
G
H
I
J
K
L
M
N
O
P

WT

SERVICE DATA AND SPECIFICATIONS (SDS)

< SERVICE DATA AND SPECIFICATIONS (SDS)

SERVICE DATA AND SPECIFICATIONS (SDS)

SERVICE DATA AND SPECIFICATIONS (SDS)

Road Wheel

INFOID:000000009134888

Item		Limit
Radial runout	Lateral runout mm (in)	Less than 0.3 mm (0.012 in)
	Radial runout mm (in)	
Allowable imbalance	Dynamic (at rim flange)	Less than 5 g (0.18 oz) (one side)
	Static (at rim flange)	Less than 10 g (0.35 oz)
Wheel nut torque		113 N·m (12 kg-m, 83 ft-lb)

Tire Air Pressure

INFOID:000000009134889

Unit: kPa (kgf/cm², psi)

Item	Standard	
	Front	Rear
235/65R18 (Conventional)	230 (2.35, 33)	
235/55R20 (Conventional)	240 (2.45, 35)	
T165/90D18 (Spare)	420 (4.28, 60)	