

SECTION **FAX**
FRONT AXLE

A
B
C

FAX

CONTENTS

E

2WD			
SYMPTOM DIAGNOSIS	3	NOISE, VIBRATION AND HARSHNESS (NVH) TROUBLESHOOTING	10
NOISE, VIBRATION AND HARSHNESS (NVH) TROUBLESHOOTING	3	NVH Troubleshooting Chart	10
NVH Troubleshooting Chart	3	PRECAUTION	11
PRECAUTION	4	PRECAUTIONS	11
PRECAUTIONS	4	Precaution for Supplemental Restraint System (SRS) "AIR BAG" and "SEAT BELT PRE-TENSIONER"	11
Precaution for Supplemental Restraint System (SRS) "AIR BAG" and "SEAT BELT PRE-TENSIONER"	4	Precautions for Drive Shaft	11
Precautions for Removing Battery Terminal	4	Precautions for Removing Battery Terminal	12
PREPARATION	5	PREPARATION	13
PREPARATION	5	Special Service Tool	13
Commercial Service Tool	5	Commercial Service Tool	14
PERIODIC MAINTENANCE	6	PERIODIC MAINTENANCE	15
FRONT WHEEL HUB AND KNUCKLE	6	FRONT WHEEL HUB AND KNUCKLE	15
Inspection	6	Inspection	15
REMOVAL AND INSTALLATION	7	FRONT DRIVE SHAFT	16
FRONT WHEEL HUB AND KNUCKLE	7	Inspection	16
Exploded View	7	REMOVAL AND INSTALLATION	17
Removal and Installation	7	FRONT WHEEL HUB AND KNUCKLE	17
Inspection	8	Exploded View	17
SERVICE DATA AND SPECIFICATIONS (SDS)	9	Removal and Installation	17
SERVICE DATA AND SPECIFICATIONS (SDS)	9	Inspection	18
Wheel Bearing	9	FRONT DRIVE SHAFT BOOT	19
AWD		Exploded View	19
SYMPTOM DIAGNOSIS	10	WHEEL SIDE	20
		WHEEL SIDE : Removal and Installation	20
		FINAL DRIVE SIDE	25
		FINAL DRIVE SIDE : Removal and Installation	25
		Inspection	26

F

G

H

I

J

K

L

M

N

O

P

FRONT DRIVE SHAFT	27	FINAL DRIVE SIDE	32
Exploded View	27	FINAL DRIVE SIDE : Disassembly and Assembly...	32
LEFT SIDE	28	Inspection	35
LEFT SIDE : Removal and Installation	28	SERVICE DATA AND SPECIFICATIONS	
RIGHT SIDE	29	(SDS)	37
RIGHT SIDE : Removal and Installation	29	SERVICE DATA AND SPECIFICATIONS	
WHEEL SIDE	30	(SDS)	37
WHEEL SIDE : Disassembly and Assembly	30	Wheel Bearing	37
		Drive Shaft	37

NOISE, VIBRATION AND HARSHNESS (NVH) TROUBLESHOOTING

< SYMPTOM DIAGNOSIS >

[2WD]

SYMPTOM DIAGNOSIS

NOISE, VIBRATION AND HARSHNESS (NVH) TROUBLESHOOTING

NVH Troubleshooting Chart

INFOID:0000000010578185

Use chart below to find the cause of the symptom. If necessary, repair or replace these parts.

Reference		FAX-7	—	FAX-6	NVH in FAX and FSU sections	NVH in WT section	NVH in WT section	Refer to DRIVE SHAFT in this chart.	NVH in BR section	NVH in ST section
Possible cause and SUSPECTED PARTS		Improper installation, looseness	Parts interference	Wheel bearing damage	FRONT AXLE AND FRONT SUSPENSION	TIRE	ROAD WHEEL	DRIVE SHAFT	BRAKE	STEERING
Symptom	FRONT AXLE	Noise	x	x	x	x	x	x	x	x
		Shake	x	x	x	x	x	x	x	x
		Vibration	x	x	x	x		x		x
		Shimmy	x	x		x	x		x	x
		Judder	x			x	x		x	x
		Poor quality ride or handling	x	x		x	x			

x: Applicable

A
B
C
E
F
G
H
I
J
K
L
M
N
O
P

FAX

PRECAUTION

PRECAUTIONS

Precaution for Supplemental Restraint System (SRS) "AIR BAG" and "SEAT BELT PRE-TENSIONER"

INFOID:000000010578186

The Supplemental Restraint System such as "AIR BAG" and "SEAT BELT PRE-TENSIONER", used along with a front seat belt, helps to reduce the risk or severity of injury to the driver and front passenger for certain types of collision. This system includes seat belt switch inputs and dual stage front air bag modules. The SRS system uses the seat belt switches to determine the front air bag deployment, and may only deploy one front air bag, depending on the severity of a collision and whether the front occupants are belted or unbelted. Information necessary to service the system safely is included in the "SRS AIR BAG" and "SEAT BELT" of this Service Manual.

WARNING:

Always observe the following items for preventing accidental activation.

- To avoid rendering the SRS inoperative, which could increase the risk of personal injury or death in the event of a collision that would result in air bag inflation, all maintenance must be performed by an authorized NISSAN/INFINITI dealer.
- Improper maintenance, including incorrect removal and installation of the SRS, can lead to personal injury caused by unintentional activation of the system. For removal of Spiral Cable and Air Bag Module, see "SRS AIR BAG".
- Never use electrical test equipment on any circuit related to the SRS unless instructed to in this Service Manual. SRS wiring harnesses can be identified by yellow and/or orange harnesses or harness connectors.

PRECAUTIONS WHEN USING POWER TOOLS (AIR OR ELECTRIC) AND HAMMERS

WARNING:

Always observe the following items for preventing accidental activation.

- When working near the Air Bag Diagnosis Sensor Unit or other Air Bag System sensors with the ignition ON or engine running, never use air or electric power tools or strike near the sensor(s) with a hammer. Heavy vibration could activate the sensor(s) and deploy the air bag(s), possibly causing serious injury.
- When using air or electric power tools or hammers, always switch the ignition OFF, disconnect the battery, and wait at least 3 minutes before performing any service.

Precautions for Removing Battery Terminal

INFOID:000000010767903

- When removing the 12V battery terminal, turn OFF the ignition switch and wait at least 30 seconds.

NOTE:

ECU may be active for several tens of seconds after the ignition switch is turned OFF. If the battery terminal is removed before ECU stops, then a DTC detection error or ECU data corruption may occur.

- For vehicles with the 2-batteries, be sure to connect the main battery and the sub battery before turning ON the ignition switch.

NOTE:

If the ignition switch is turned ON with any one of the terminals of main battery and sub battery disconnected, then DTC may be detected.

- After installing the 12V battery, always check "Self Diagnosis Result" of all ECUs and erase DTC.

NOTE:

The removal of 12V battery may cause a DTC detection error.

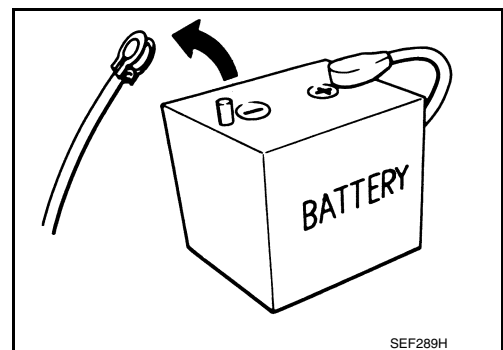

PREPARATION

< PREPARATION >

[2WD]

PREPARATION

PREPARATION

Commercial Service Tool

INFOID:0000000010578187

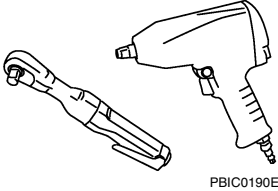
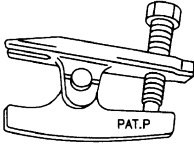
Tool name	Description
<p data-bbox="165 415 277 441">Power tool</p>  <p data-bbox="829 632 899 646">PBIC0190E</p>	<p data-bbox="1010 415 1260 441">Loosening bolts and nuts</p>
<p data-bbox="165 667 342 693">Ball joint remover</p>  <p data-bbox="792 821 829 835">PAT.P</p> <p data-bbox="829 884 867 898">NT146</p>	<p data-bbox="1010 667 1403 693">Removing ball joint for steering knuckle</p>

A

B

C

FAX

E

F

G

H

I

J

K

L

M

N

O

P

PERIODIC MAINTENANCE

FRONT WHEEL HUB AND KNUCKLE

Inspection

INFOID:0000000010578188

MOUNTING INSPECTION

Make sure that the mounting conditions (looseness, backlash) of each component and component conditions (wear, damage) are normal.

WHEEL BEARING INSPECTION

- Move wheel hub and bearing assembly in the axial direction by hand. Make sure there is no looseness of wheel bearing.

Axial end play : Refer to [FAX-9, "Wheel Bearing"](#).

- Rotate wheel hub and make sure there is no unusual noise or other irregular conditions. If there is any of irregular conditions, replace wheel hub and bearing assembly.

FRONT WHEEL HUB AND KNUCKLE

< REMOVAL AND INSTALLATION >

[2WD]

REMOVAL AND INSTALLATION

FRONT WHEEL HUB AND KNUCKLE

Exploded View

INFOID:0000000010578189

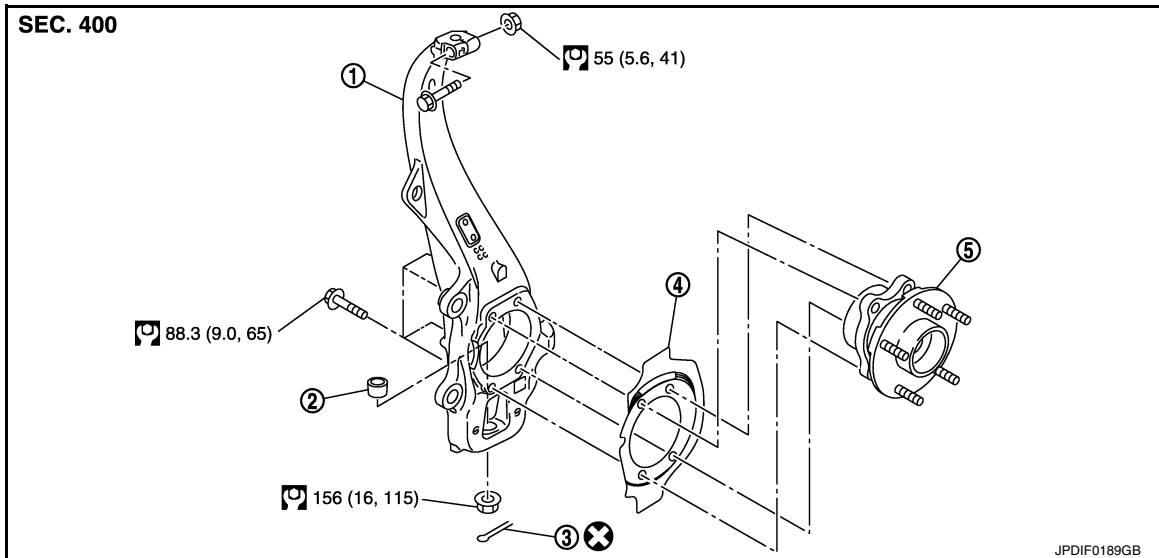

- | | | |
|---------------------|-----------------------------------|---------------|
| 1. Steering knuckle | 2. Ball seat | 3. Cotter pin |
| 4. Splash guard | 5. Wheel hub and bearing assembly | |

⊗: Always replace after every disassembly.

⊞: N·m (kg·m, ft·lb)

Removal and Installation

INFOID:0000000010578190

REMOVAL

1. Remove tires with power tool.
2. Remove wheel sensor and sensor harness. Refer to [BRC-133, "FRONT WHEEL SENSOR : Exploded View"](#).
CAUTION:
Never pull on wheel sensor harness.
3. Remove brake hose bracket. Refer to [BR-22, "FRONT : Exploded View"](#).
4. Remove caliper assembly with power tool. Hang caliper assembly in a place where it will not interfere with work. Refer to [BR-45, "BRAKE CALIPER ASSEMBLY \(2 PISTON TYPE\) : Exploded View"](#).
CAUTION:
Never depress brake pedal while brake caliper is removed.
5. Remove disc rotor. Refer to [BR-46, "BRAKE CALIPER ASSEMBLY \(2 PISTON TYPE\) : Removal and Installation"](#).
6. Remove wheel hub and bearing assembly, and then remove splash guard.
7. Remove steering outer socket. Refer to [ST-26, "Exploded View"](#).
8. Remove cotter pin of transverse link and steering knuckle, and then loosen nut.
9. Separate steering knuckle from upper link.
10. Separate steering knuckle from transverse link so as not to damage ball joint boot using the ball joint remover, and remove steering knuckle.
CAUTION:
Temporarily tighten the nut to prevent damage to threads and to prevent the ball joint remover from suddenly coming off.

INSTALLATION

FRONT WHEEL HUB AND KNUCKLE

< REMOVAL AND INSTALLATION >

[2WD]

Note the following, and install in the reverse order of the removal.

- Perform the final tightening of each of parts under unladen conditions, which were removed when removing wheel hub and bearing assembly and steering knuckle.
- Never reuse cotter pin.

Inspection

INFOID:0000000010578191

INSPECTION AFTER REMOVAL

Check components for deformation, cracks, and other damage. Replace it if necessary.

Ball Joint Inspection

Check boots of transverse link and steering outer socket ball joint for breakage, axial play, and torque. Refer to [FSU-14, "Inspection"](#) and [ST-34, "Inspection"](#).

INSPECTION AFTER INSTALLATION

1. Check wheel sensor harness for proper connection. Refer to [BRC-133, "FRONT WHEEL SENSOR : Exploded View"](#).
2. Check the wheel alignment. Refer to [FSU-8, "Inspection"](#).
3. Adjust neutral position of steering angle sensor. Refer to [BRC-9, "ADJUSTMENT OF STEERING ANGLE SENSOR NEUTRAL POSITION : Special Repair Requirement"](#).

SERVICE DATA AND SPECIFICATIONS (SDS)

< SERVICE DATA AND SPECIFICATIONS (SDS)

[2WD]

SERVICE DATA AND SPECIFICATIONS (SDS)

SERVICE DATA AND SPECIFICATIONS (SDS)

Wheel Bearing

INFOID:0000000010578192

Item	Standard
Axial end play	0.05 mm (0.002 in) or less

A
B
C
E
F
G
H
I
J
K
L
M
N
O
P

FAX

NOISE, VIBRATION AND HARSHNESS (NVH) TROUBLESHOOTING

< SYMPTOM DIAGNOSIS >

[AWD]

SYMPTOM DIAGNOSIS

NOISE, VIBRATION AND HARSHNESS (NVH) TROUBLESHOOTING

NVH Troubleshooting Chart

INFOID:0000000010578193

Use chart below to find the cause of the symptom. If necessary, repair or replace these parts.

		Reference												
		—	FAX-35	—	FAX-17	—	FAX-15	NVH in FAX and FSU sections	Refer to FRONT AXLE in this chart.	NVH in WT section	NVH in WT section	Refer to DRIVE SHAFT in this chart.	NVH in BR section	NVH in ST section
		Possible cause and SUSPECTED PARTS												
		Excessive joint angle	Joint sliding resistance	Imbalance	Improper installation, looseness	Parts interference	Wheel bearing damage	FRONT AXLE AND FRONT SUSPENSION	FRONT AXLE	TIRE	ROAD WHEEL	DRIVE SHAFT	BRAKE	STEERING
Symptom	DRIVE SHAFT	Noise	x	x			x	x	x	x	x		x	x
		Shake	x		x		x	x	x	x	x		x	x
	FRONT AXLE	Noise				x	x	x	x	x	x	x	x	x
		Shake				x	x	x	x	x	x	x	x	x
		Vibration				x	x	x	x	x		x		x
		Shimmy				x	x		x	x	x		x	x
		Judder				x			x	x	x		x	x
		Poor quality ride or handling				x	x		x		x	x		

x: Applicable

PRECAUTION

PRECAUTIONS

Precaution for Supplemental Restraint System (SRS) "AIR BAG" and "SEAT BELT PRE-TENSIONER"

INFOID:000000010578194

The Supplemental Restraint System such as "AIR BAG" and "SEAT BELT PRE-TENSIONER", used along with a front seat belt, helps to reduce the risk or severity of injury to the driver and front passenger for certain types of collision. This system includes seat belt switch inputs and dual stage front air bag modules. The SRS system uses the seat belt switches to determine the front air bag deployment, and may only deploy one front air bag, depending on the severity of a collision and whether the front occupants are belted or unbelted. Information necessary to service the system safely is included in the "SRS AIR BAG" and "SEAT BELT" of this Service Manual.

WARNING:

Always observe the following items for preventing accidental activation.

- To avoid rendering the SRS inoperative, which could increase the risk of personal injury or death in the event of a collision that would result in air bag inflation, all maintenance must be performed by an authorized NISSAN/INFINITI dealer.
- Improper maintenance, including incorrect removal and installation of the SRS, can lead to personal injury caused by unintentional activation of the system. For removal of Spiral Cable and Air Bag Module, see "SRS AIR BAG".
- Never use electrical test equipment on any circuit related to the SRS unless instructed to in this Service Manual. SRS wiring harnesses can be identified by yellow and/or orange harnesses or harness connectors.

PRECAUTIONS WHEN USING POWER TOOLS (AIR OR ELECTRIC) AND HAMMERS

WARNING:

Always observe the following items for preventing accidental activation.

- When working near the Air Bag Diagnosis Sensor Unit or other Air Bag System sensors with the ignition ON or engine running, never use air or electric power tools or strike near the sensor(s) with a hammer. Heavy vibration could activate the sensor(s) and deploy the air bag(s), possibly causing serious injury.
- When using air or electric power tools or hammers, always switch the ignition OFF, disconnect the battery, and wait at least 3 minutes before performing any service.

Precautions for Drive Shaft

INFOID:000000010578195

- Observe the following precautions when disassembling and assembling drive shaft.
- Never disassemble joint sub-assembly because it is non-overhaul parts.
- Perform work in a location which is as dust-free as possible.
- Clean the parts, before disassembling and assembling.
- Prevent the entry of foreign objects during disassembly of the service location.
- Reassemble disassembled parts carefully in the correct order. If work is interrupted, a clean cover must be placed over parts.
- Use paper waste. Fabric shop cloths must not be used because of the danger of lint adhering to parts.
- Clean disassembled parts (except for rubber parts) with kerosene which shall be removed by blowing with air or wiping with paper waste.

A
B
C
FAX
E
F
G
H
I
J
K
L
M
N
O
P

PRECAUTIONS

[AWD]

< PRECAUTION >

Precautions for Removing Battery Terminal

INFOID:000000010767979

- When removing the 12V battery terminal, turn OFF the ignition switch and wait at least 30 seconds.

NOTE:

ECU may be active for several tens of seconds after the ignition switch is turned OFF. If the battery terminal is removed before ECU stops, then a DTC detection error or ECU data corruption may occur.

- For vehicles with the 2-batteries, be sure to connect the main battery and the sub battery before turning ON the ignition switch.

NOTE:

If the ignition switch is turned ON with any one of the terminals of main battery and sub battery disconnected, then DTC may be detected.

- After installing the 12V battery, always check "Self Diagnosis Result" of all ECUs and erase DTC.

NOTE:

The removal of 12V battery may cause a DTC detection error.

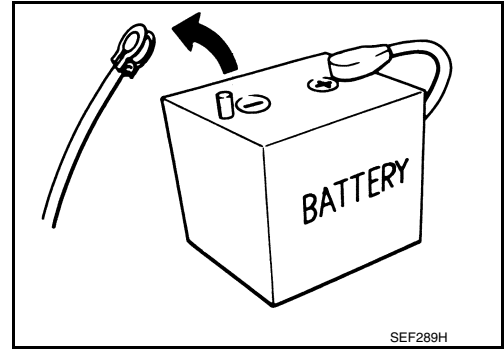

PREPARATION

[AWD]

< PREPARATION >



PREPARATION

PREPARATION

Special Service Tool

INFOID:0000000010578196

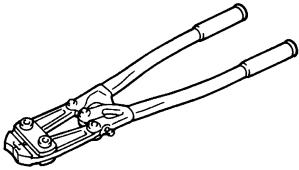
The actual shapes of TechMate tools may differ from those of special service tools illustrated here.

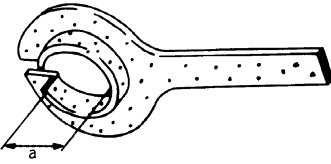
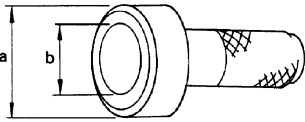
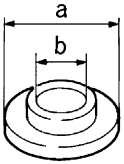
Tool number (TechMate No.) Tool name	Description
KV40107300 (-) Boot band crimping tool	Installing boot band
 <p style="text-align: center;">ZZA1229D</p>	
KV40107500 (-) Drive shaft attachment	Removing drive shaft
 <p style="text-align: center;">ZZA1230D</p>	
KV38107900 (-) Protector a: 32 mm (1.26 in) dia.	Installing drive shaft
 <p style="text-align: center;">PDA1183J</p>	
KV38100500 (-) Drift a: 80 mm (3.15 in) dia. b: 60 mm (2.36 in) dia.	Installing drive shaft plug
 <p style="text-align: center;">ZZA0701D</p>	
KV38102200 (-) Drift a: 90 mm (3.54 in) dia. b: 31 mm (1.22 in) dia.	Installing drive shaft plug
 <p style="text-align: center;">ZZA0920D</p>	

A
B
C
FAX
E
F
G
H
I
J
K
L
M
N
O
P

PREPARATION

< PREPARATION >

[AWD]

Commercial Service Tool

INFOID:000000010578197

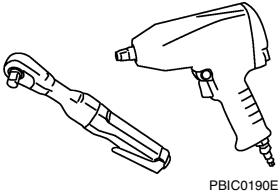
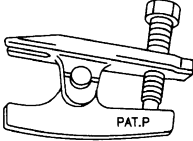
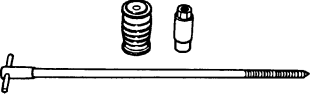
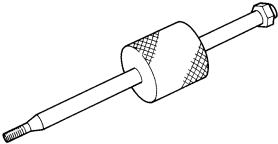
Tool name	Description
<p data-bbox="164 289 272 317">Power tool</p>  <p data-bbox="824 506 896 522">PBIC0190E</p>	<p data-bbox="1003 289 1260 317">Loosening bolts and nuts</p>
<p data-bbox="164 541 337 569">Ball joint remover</p>  <p data-bbox="786 695 824 711">PAT.P</p> <p data-bbox="824 758 870 774">NT146</p>	<p data-bbox="1003 541 1401 569">Removing ball joint for steering knuckle</p>
<p data-bbox="164 795 334 823">Drive shaft puller</p>  <p data-bbox="824 1010 912 1026">JPDIG0152ZZ</p>	<p data-bbox="1003 795 1414 823">Removing drive shaft joint sub assembly</p>
<p data-bbox="164 1047 321 1075">Sliding hummer</p>  <p data-bbox="824 1262 896 1278">ZZA0023D</p>	<p data-bbox="1003 1047 1222 1075">Removing drive shaft</p>

FRONT WHEEL HUB AND KNUCKLE

< PERIODIC MAINTENANCE >

[AWD]

PERIODIC MAINTENANCE

FRONT WHEEL HUB AND KNUCKLE

Inspection

INFOID:0000000010578198

MOUNTING INSPECTION

Make sure that the mounting conditions (looseness, backlash) of each component and component conditions (wear, damage) are normal.

WHEEL BEARING INSPECTION

- Move wheel hub and bearing assembly in the axial direction by hand. Make sure there is no looseness of wheel bearing.

Axial end play : Refer to [FAX-37, "Wheel Bearing"](#).

- Rotate wheel hub and make sure there is no unusual noise or other irregular conditions. If there is any of irregular conditions, replace wheel hub and bearing assembly.

A
B
C
FAX
E
F
G
H
I
J
K
L
M
N
O
P

FRONT DRIVE SHAFT

< PERIODIC MAINTENANCE >

[AWD]

FRONT DRIVE SHAFT

Inspection

INFOID:000000010578199

- Check drive shaft mounting point and joint for looseness and other damage.
- Check boot for cracks and other damage.

CAUTION:

Replace entire drive shaft assembly when noise or vibration occur from drive shaft.

FRONT WHEEL HUB AND KNUCKLE

< REMOVAL AND INSTALLATION >

[AWD]

REMOVAL AND INSTALLATION

FRONT WHEEL HUB AND KNUCKLE

Exploded View

INFOID:0000000010578200

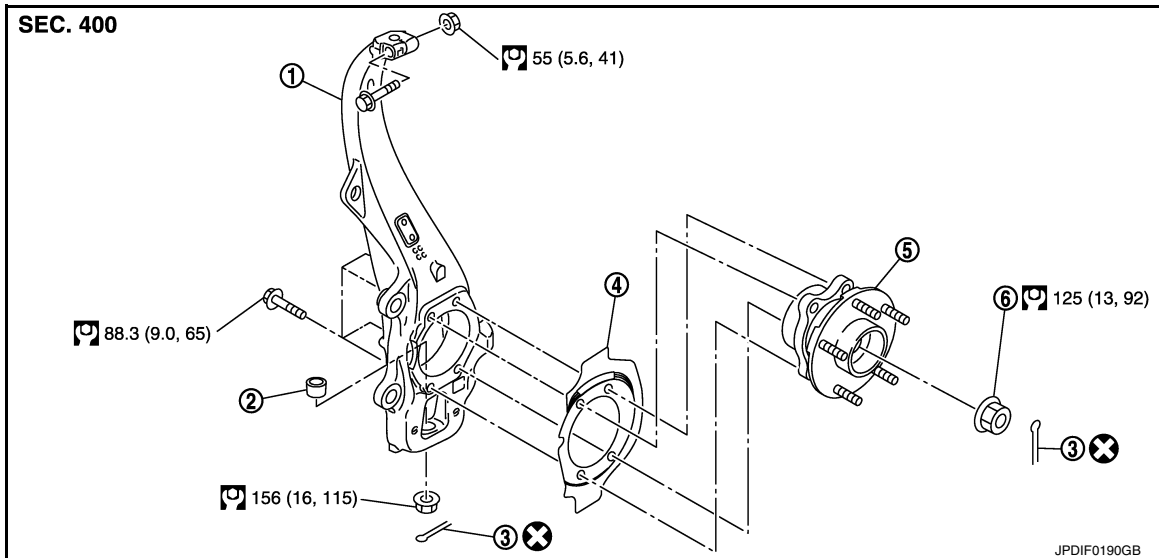

- | | | |
|---------------------|-----------------------------------|-----------------------|
| 1. Steering knuckle | 2. Ball seat | 3. Cotter pin |
| 4. Splash guard | 5. Wheel hub and bearing assembly | 6. Wheel hub lock nut |

⊗: Always replace after every disassembly.

Ⓜ: N·m (kg·m, ft·lb)

Removal and Installation

INFOID:0000000010578201

REMOVAL

1. Remove tires with power tool.
2. Remove wheel sensor and sensor harness. Refer to [BRC-133, "FRONT WHEEL SENSOR : Exploded View"](#).
CAUTION:
Never pull on wheel sensor harness.
3. Remove brake hose bracket. Refer to [BR-22, "FRONT : Exploded View"](#).
4. Remove caliper assembly with power tool. Hang caliper assembly in a place where it will not interfere with work. Refer to [BR-45, "BRAKE CALIPER ASSEMBLY \(2 PISTON TYPE\) : Exploded View"](#) (2 piston type), [BR-49, "BRAKE CALIPER ASSEMBLY \(4 PISTON TYPE\) : Exploded View"](#) (4 piston type).
CAUTION:
Never depress brake pedal while brake caliper is removed.
5. Remove disc rotor. Refer to [BR-46, "BRAKE CALIPER ASSEMBLY \(2 PISTON TYPE\) : Removal and Installation"](#) (2 piston type), [BR-50, "BRAKE CALIPER ASSEMBLY \(4 PISTON TYPE\) : Removal and Installation"](#) (4 piston type).
6. Remove cotter pin, and then loosen wheel hub lock nut with power tool.

FRONT WHEEL HUB AND KNUCKLE

< REMOVAL AND INSTALLATION >

[AWD]

7. Patch wheel hub lock nut with a piece of wood. Hammer the wood to disengage wheel hub and bearing assembly from drive shaft.

CAUTION:

- Never place drive shaft joint at an extreme angle. Also be careful not to overextend slide joint.
- Never allow drive shaft to hang down without support for or joint sub-assembly, shaft and the other parts.

NOTE:

Use suitable puller, if wheel hub and bearing assembly and drive shaft cannot be separated even after performing the above procedure.

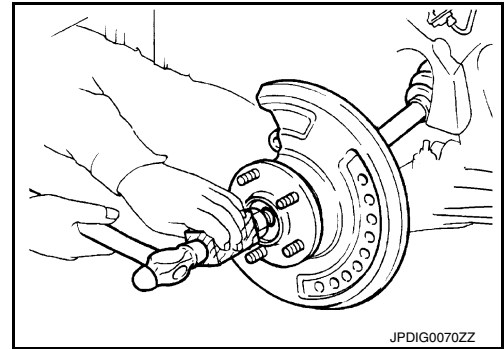

8. Remove wheel hub lock nut.
9. Remove wheel hub and bearing assembly, and then remove splash guard.
10. Remove steering outer socket. Refer to [ST-26, "Exploded View"](#).
11. Remove cotter pin of transverse link and steering knuckle, and then loosen nut.
12. Separate steering knuckle from upper link.
13. Separate steering knuckle link from transverse so as not to damage ball joint boot using the ball joint remover, and remove steering knuckle.

CAUTION:

Temporarily tighten the nut to prevent damage to threads and to prevent the ball joint remover from suddenly coming off.

INSTALLATION

Note the following, and install in the reverse order of the removal.

- Perform the final tightening of each of parts under unladen conditions, which were removed when removing wheel hub and bearing assembly and steering knuckle.
- Install drive shaft using tightening torque of wheel hub lock nut. Refer to [FAX-17, "Exploded View"](#).

CAUTION:

- Be sure to use torque wrench to tighten the wheel hub lock nut. Never use a power tool.
- Never reuse cotter pin.

Inspection

INFOID:0000000010578202

INSPECTION AFTER REMOVAL

Check components for deformation, cracks, and other damage. Replace it if necessary.

Ball Joint Inspection

Check boots of transverse link and steering outer socket ball joint for breakage, axial play, and torque. Refer to [FSU-34, "Inspection"](#) and [ST-34, "Inspection"](#).

INSPECTION AFTER INSTALLATION

1. Check wheel sensor harness for proper connection. Refer to [BRC-133, "FRONT WHEEL SENSOR : Exploded View"](#).
2. Check the wheel alignment. Refer to [FSU-28, "Inspection"](#).
3. Adjust neutral position of steering angle sensor. Refer to [BRC-9, "ADJUSTMENT OF STEERING ANGLE SENSOR NEUTRAL POSITION : Special Repair Requirement"](#).

FRONT DRIVE SHAFT BOOT

[AWD]

< REMOVAL AND INSTALLATION >

FRONT DRIVE SHAFT BOOT

Exploded View

INFOID:000000010578203

LEFT SIDE

VQ37VHR

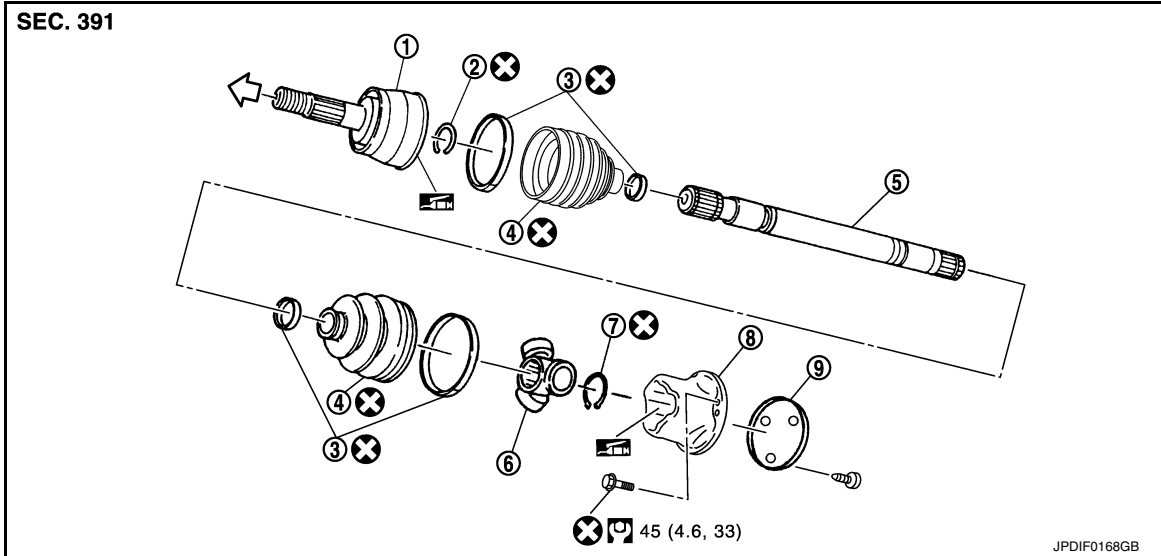

- | | | |
|-----------------------|------------------|--------------------|
| 1. Joint sub-assembly | 2. Circular clip | 3. Boot band |
| 4. Boot | 5. Shaft | 6. Spider assembly |
| 7. Snap ring | 8. Housing | 9. Plug |

← Wheel side

NISSAN genuine grease or an equivalent.

N·m (kg·m, ft·lb)

Always replace after every disassembly.

VK50VE

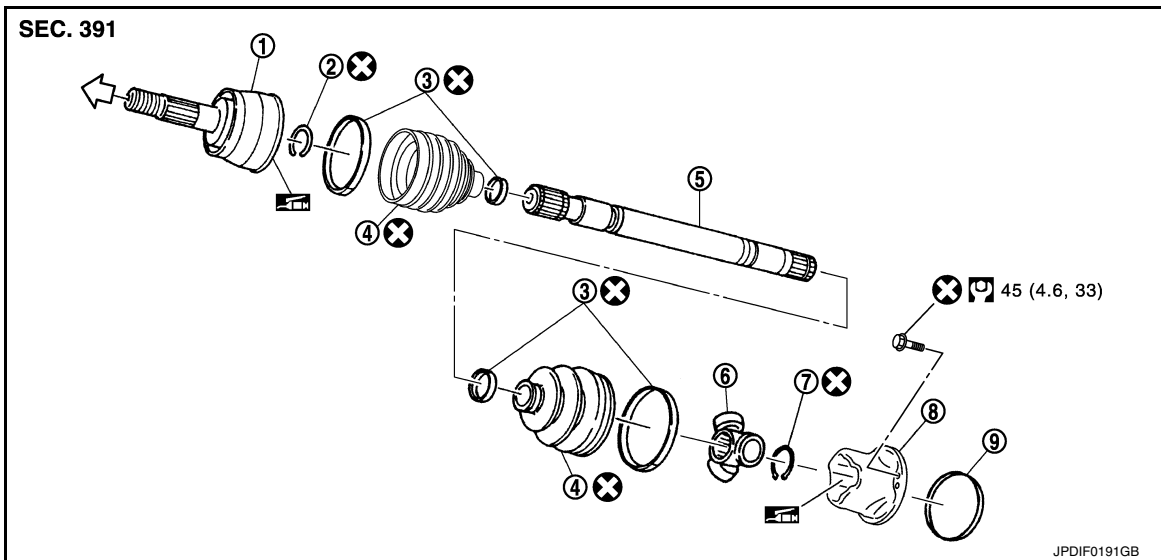

- | | | |
|-----------------------|------------------|--------------------|
| 1. Joint sub-assembly | 2. Circular clip | 3. Boot band |
| 4. Boot | 5. Shaft | 6. Spider assembly |
| 7. Snap ring | 8. Housing | 9. Plug |

← Wheel side

A
B
C
FAX
E
F
G
H
I
J
K
L
M
N
O
P

FRONT DRIVE SHAFT BOOT

[AWD]

< REMOVAL AND INSTALLATION >

: N·m (kg-m, ft-lb)

: Always replace after every disassembly.

: NISSAN genuine grease or an equivalent.

RIGHT SIDE

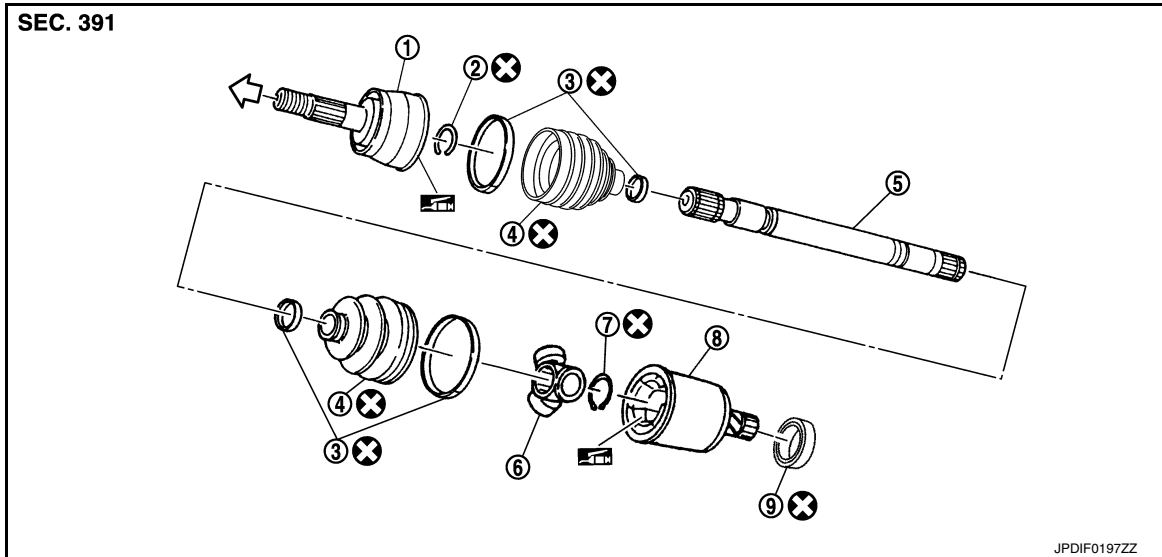

1. Joint sub-assembly

2. Circular clip

3. Boot band

4. Boot

5. Shaft

6. Spider assembly

7. Snap ring

8. Housing

9. Dust shield

: Wheel side

: NISSAN genuine grease or an equivalent.

: N·m (kg-m, ft-lb)

: Always replace after every disassembly.

WHEEL SIDE

WHEEL SIDE : Removal and Installation

INFOID:000000010578204

REMOVAL

Left Side

1. Remove tires with power tool.
2. Remove wheel sensor and sensor harness. Refer to [BRC-133, "FRONT WHEEL SENSOR : Exploded View"](#).
CAUTION:
Never pull on wheel sensor harness.
3. Remove brake hose bracket. Refer to [BR-22, "FRONT : Exploded View"](#).
4. Remove caliper assembly mounting bolts with power tool. Hang caliper assembly in a place where it will not interfere with work. Refer to [BR-45, "BRAKE CALIPER ASSEMBLY \(2 PISTON TYPE\) : Exploded View"](#) (2 piston type), [BR-49, "BRAKE CALIPER ASSEMBLY \(4 PISTON TYPE\) : Exploded View"](#) (4 piston type).
CAUTION:
Never depress brake pedal while brake caliper is removed.
5. Remove disc rotor. Refer to [BR-46, "BRAKE CALIPER ASSEMBLY \(2 PISTON TYPE\) : Removal and Installation"](#) (2 piston type), [BR-50, "BRAKE CALIPER ASSEMBLY \(4 PISTON TYPE\) : Removal and Installation"](#) (4 piston type).

FRONT DRIVE SHAFT BOOT

[AWD]

< REMOVAL AND INSTALLATION >

- Remove cotter pin, and then loosen wheel hub lock nut with a power tool. Refer to [FAX-17. "Exploded View"](#).
- Patch wheel hub lock nut with a piece of wood. Hammer the wood to disengage wheel hub and bearing assembly from drive shaft.

CAUTION:

- Never place drive shaft joint at an extreme angle. Also be careful not to overextend slide joint.
- Never allow drive shaft to hang down without support for joint sub-assembly, shaft and the other parts.

NOTE:

Use suitable puller if wheel hub and bearing assembly and drive shaft cannot be separated even after performing the above procedure.

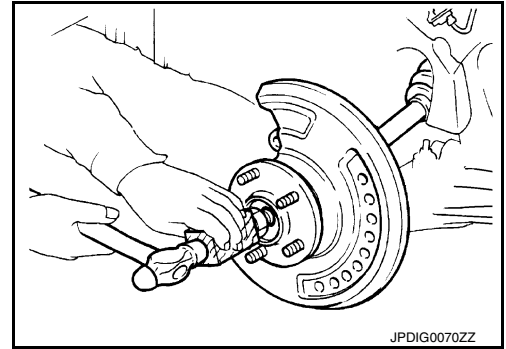

- Remove wheel hub lock nut.
- Remove steering outer socket. Refer to [ST-26. "Exploded View"](#).
- Separate upper link from steering knuckle. Refer to [FAX-17. "Exploded View"](#).
- Remove drive shaft from wheel hub and bearing assembly.
- Remove boot bands, and then remove boot from joint sub-assembly.
- Screw drive shaft puller (commercial service tool) (A) 30 mm (1.18 in) or more into the thread of joint sub-assembly, and pull joint sub-assembly from shaft.

CAUTION:

- Align a sliding hammer and drive shaft and remove them by pulling firmly and uniformly.
- If joint sub-assembly cannot be pulled out, try after removing drive shaft from vehicle.

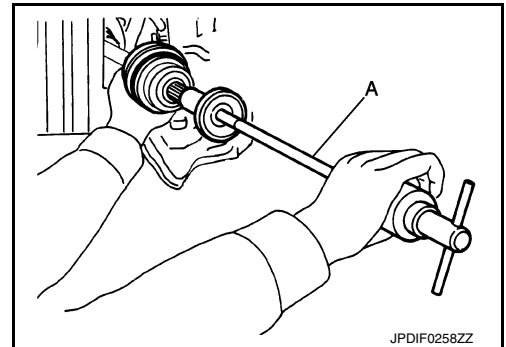

- Remove circular clip (1) from shaft.
- Remove boot from shaft.

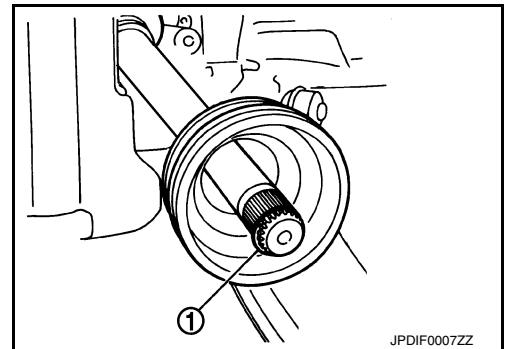

Right Side

- Remove drive shaft from vehicle. Refer to [FAX-29. "RIGHT SIDE : Removal and Installation"](#).
- Fix shaft with a vise.
CAUTION:
Protect shaft when fixing with a vise using aluminum or copper plates.
- Remove boot bands, and then remove boot from joint sub-assembly.

A
B
C
FAX
E
F
G
H
I
J
K
L
M
N
O
P

FRONT DRIVE SHAFT BOOT

[AWD]

< REMOVAL AND INSTALLATION >

4. Screw drive shaft puller (commercial service tool) (A) 30 mm (1.18 in) or more into the thread of joint sub-assembly, and pull joint sub-assembly from shaft.

CAUTION:

- Align a sliding hammer and drive shaft and remove them by pulling firmly and uniformly.
- If joint sub-assembly cannot be removed after five or more unsuccessful attempts, replace shaft and joint sub-assembly as a set.

5. Remove circular clip from shaft.
6. Remove boot from shaft.

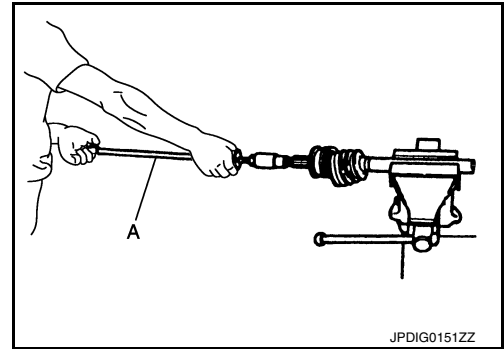

INSTALLATION

Left Side

1. Clean the old grease on joint sub-assembly with paper waste.
2. Fill serration slot joint sub-assembly (1) with NISSAN genuine grease or equivalent until the serration slot and ball groove become full to the brim.

CAUTION:

After applying grease, use a shop cloth to wipe off old grease that has oozed out.

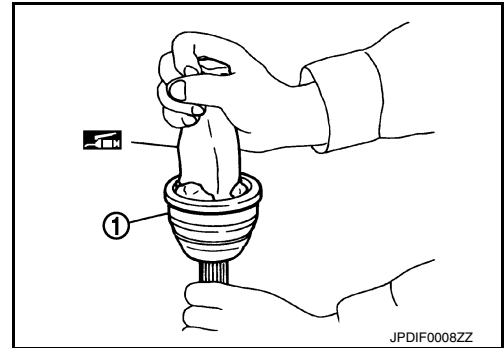

3. Install boot and boot bands to shaft.

CAUTION:

- Wrap serration on shaft with tape (A) to protect the boot from damage.
- Never reuse boot and boot band.

4. Remove the tape wrapped around the serration on shaft.

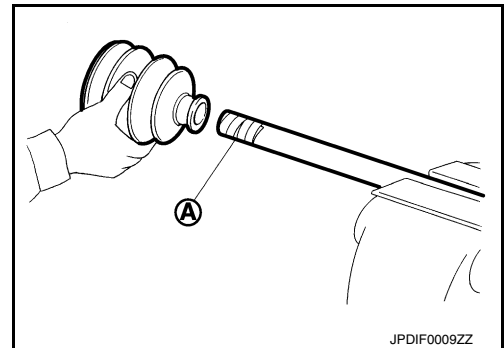

5. Position circular clip (1) on groove at the shaft edge.

CAUTION:

Never reuse circular clip.

NOTE:

Drive joint inserter is recommended when installing circular clip.

6. Align both center axles of the shaft edge and joint sub-assembly. Then assemble shaft with joint sub-assembly holding circular clip.

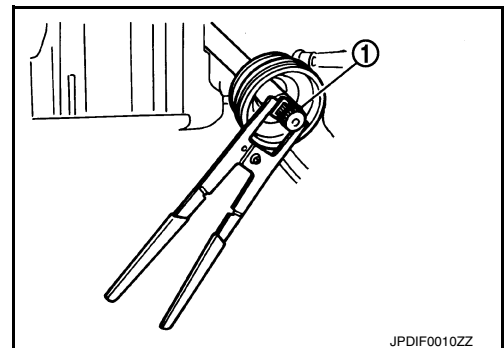

FRONT DRIVE SHAFT BOOT

< REMOVAL AND INSTALLATION >

[AWD]

7. Install joint sub-assembly (1) to shaft using plastic hammer.

CAUTION:

Confirm that joint sub-assembly is correctly engaged while rotating drive shaft.

8. Apply the specified amount of grease into the boot inside from large diameter side of boot.

Grease amount : Refer to [FAX-37, "Drive Shaft"](#).

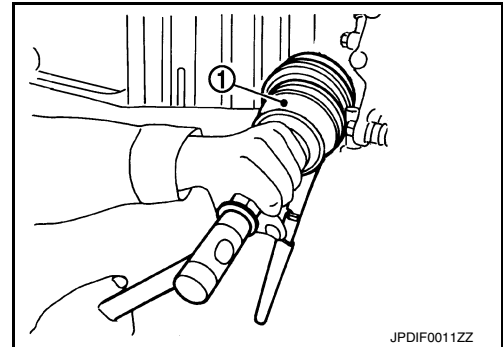

JPDIF0011ZZ

9. Install the boot securely into grooves (indicated by "*" marks) shown in the figure.

CAUTION:

If grease adheres to the boot mounting surface (indicated by "*" mark) on the shaft or joint sub-assembly, boot may come off. Remove all grease from the surface.

10. To prevent the deformation of the boot, adjust the boot installation length (L) to the specified value shown below by inserting the suitable tool into the inside of the boot from the large diameter side of the boot and discharging the inside air.

L : Refer to [FAX-37, "Drive Shaft"](#).

CAUTION:

- If the boot mounting length is outside the standard, it may cause breakage in the boot.
- Be careful not to touch the inside of the boot with a tip of tool.

11. Secure the ends of the boot with boot bands using the boot band crimping tool (A) [SST: KV40107300 (-)].

CAUTION:

Never reuse boot band.

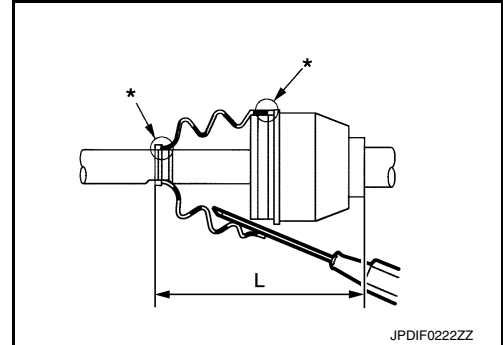

JPDIF0222ZZ

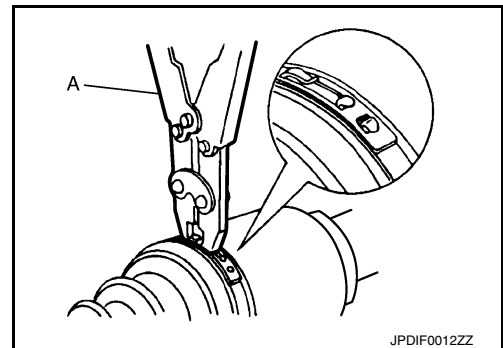

JPDIF0012ZZ

NOTE:

Secure boot band so that dimension (A) meets the specification as shown in the figure.

A : 7.0 mm (0.276 in) or less

12. Secure joint sub-assembly and shaft, and then make sure that they are in the correct position when rotating boot. Install them with boot band when boot installation positions become incorrect.

CAUTION:

Never reuse boot band.

13. Insert drive shaft to wheel hub and bearing assembly, and then temporarily tighten wheel hub lock nut.

CAUTION:

- The drive shaft is press-fit. When assembling the shaft, never press it, but pull it until fully seated by tightening the wheel hub lock nut.
- Check that anticorrosive oil is applied to the thread of the drive shaft. If not, apply appropriate oil such as engine oil.

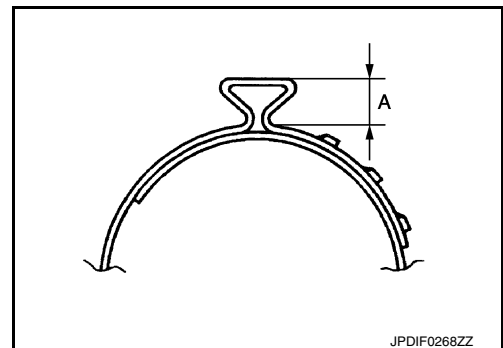

JPDIF0268ZZ

A
B
C
FAX
E
F
G
H
I
J
K
L
M
N
O
P

FRONT DRIVE SHAFT BOOT

[AWD]

< REMOVAL AND INSTALLATION >

- If sufficient oil is not applied to the thread of the drive shaft, the wheel hub lock nut may be seized and the tightening torque reaches the specified limit prematurely. It may cause looseness or abnormal noises.
14. Install steering knuckle to upper link. Refer to [FAX-17. "Exploded View"](#).
 15. Install steering outer socket to steering knuckle. Refer to [ST-26. "Exploded View"](#).
 16. Tighten the wheel hub lock nut to the specified torque, and install cotter pin. Refer to [FAX-17. "Exploded View"](#).
- CAUTION:**
- Be sure to use torque wrench to tighten the wheel hub lock nut. Never use a power tool.
 - Never reuse cotter pin.
 - Bend it at the root sufficiently to prevent any looseness.
17. Install disc rotor. Refer to [BR-46. "BRAKE CALIPER ASSEMBLY \(2 PISTON TYPE\) : Removal and Installation"](#) (2 piston type), [BR-50. "BRAKE CALIPER ASSEMBLY \(4 PISTON TYPE\) : Removal and Installation"](#) (4 piston type).
 18. Install caliper assembly to steering knuckle. Refer to [BR-45. "BRAKE CALIPER ASSEMBLY \(2 PISTON TYPE\) : Exploded View"](#) (2 piston type), [BR-49. "BRAKE CALIPER ASSEMBLY \(4 PISTON TYPE\) : Exploded View"](#) (4 piston type).
 19. Install brake hose bracket to steering knuckle. Refer to [BR-22. "FRONT : Exploded View"](#).
 20. Install wheel sensor to steering knuckle. Refer to [BRC-133. "FRONT WHEEL SENSOR : Exploded View"](#).

Right Side

1. Clean the old grease on joint sub-assembly with paper waste.
2. Fill serration slot joint sub-assembly (1) with NISSAN genuine grease or equivalent until the serration slot and ball groove become full to the brim.

CAUTION:

After applying grease, use a shop cloth to wipe off old grease that has oozed out.

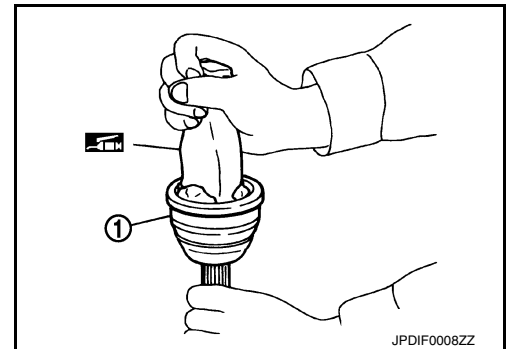

3. Install boot and boot bands to shaft.

CAUTION:

- Wrap serration on shaft with tape (A) to protect the boot from damage.
- Never reuse boot and boot band.

4. Remove the tape wrapped around the serration on shaft.
5. Position circular clip on groove at the shaft edge.

CAUTION:

Never reuse circular clip.

NOTE:

Drive joint inserter is recommended when installing circular clip.

6. Align both center axles of the shaft edge and joint sub-assembly. Then assemble shaft with joint sub-assembly holding circular clip.

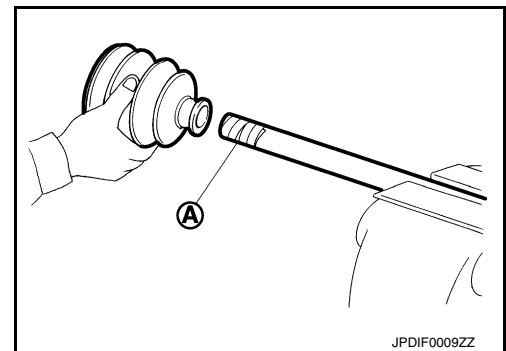

FRONT DRIVE SHAFT BOOT

[AWD]

< REMOVAL AND INSTALLATION >

7. Install joint sub-assembly (1) to shaft using plastic hammer.

CAUTION:

Confirm that joint sub-assembly is correctly engaged while rotating drive shaft.

8. Apply the specified amount of grease into the boot inside from large diameter side of boot.

Grease amount : Refer to [FAX-37, "Drive Shaft"](#).

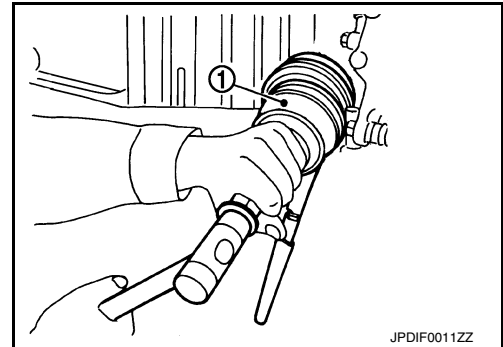

9. Install the boot securely into grooves (indicated by "*" marks) shown in the figure.

CAUTION:

If grease adheres to the boot mounting surface (indicated by "*" mark) on the shaft or joint sub-assembly, boot may come off. Remove all grease from the surface.

10. To prevent the deformation of the boot, adjust the boot installation length (L) to the specified value shown below by inserting the suitable tool into inside of the boot from the large diameter side of the boot and discharging the inside air.

L : Refer to [FAX-37, "Drive Shaft"](#).

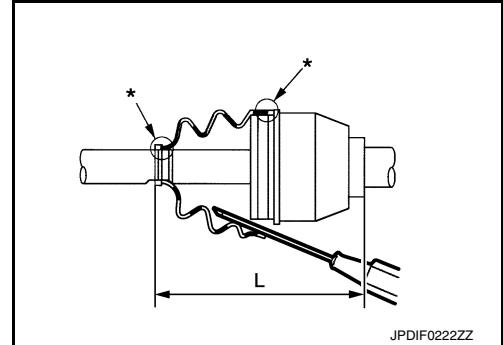

CAUTION:

- If the boot mounting length is outside the standard, it may cause breakage in the boot.
- Be careful not to touch the inside of the boot with a tip of tool.

11. Secure the ends of the boot with boot bands using the boot band crimping tool (A) [SST: KV40107300 (-)].

CAUTION:

Never reuse boot band.

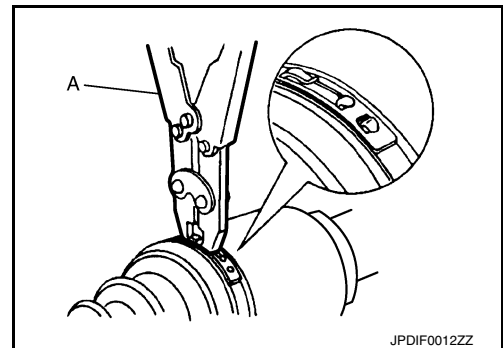

NOTE:

Secure boot band so that dimension (A) meets the specification as shown in the figure.

A : 7.0 mm (0.276 in) or less

12. Secure joint sub-assembly and shaft, and then make sure that they are in the correct position when rotating boot. Install them with boot band when boot installation positions become incorrect.

CAUTION:

Never reuse boot band.

13. Install drive shaft to vehicle. Refer to [FAX-29, "RIGHT SIDE : Removal and Installation"](#).

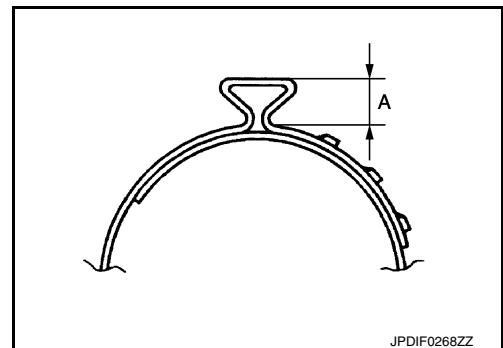

FINAL DRIVE SIDE

FINAL DRIVE SIDE : Removal and Installation

NOTE:

A
B
C
FAX
E
F
G
H
I
J
K
L
M
N
O
P

FRONT DRIVE SHAFT BOOT

[AWD]

< REMOVAL AND INSTALLATION >

Remove boot after removing drive shaft.

- Remove: refer to [FAX-28, "LEFT SIDE : Removal and Installation"](#) (left side), [FAX-29, "RIGHT SIDE : Removal and Installation"](#) (right side).
- Disassembly: refer to [FAX-32, "FINAL DRIVE SIDE : Disassembly and Assembly"](#).

Inspection

INFOID:000000010578206

INSPECTION AFTER REMOVAL

- Move joint up/down, left/right, and in the axial directions. Check for motion that is not smooth and for significant looseness.
- Check boot for cracks, damage, and leakage of grease.
- Disassemble drive shaft and exchange malfunctioning part if there is a non-standard condition.

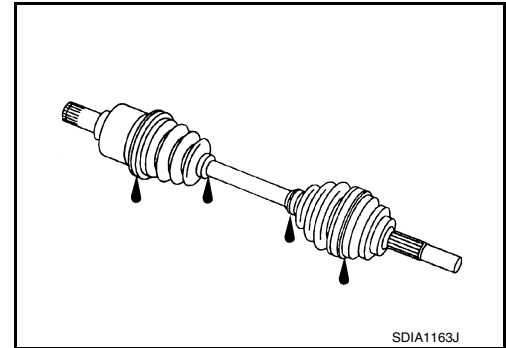

FRONT DRIVE SHAFT

< REMOVAL AND INSTALLATION >

[AWD]

FRONT DRIVE SHAFT

Exploded View

INFOID:000000010578207

LEFT SIDE

VQ37VHR

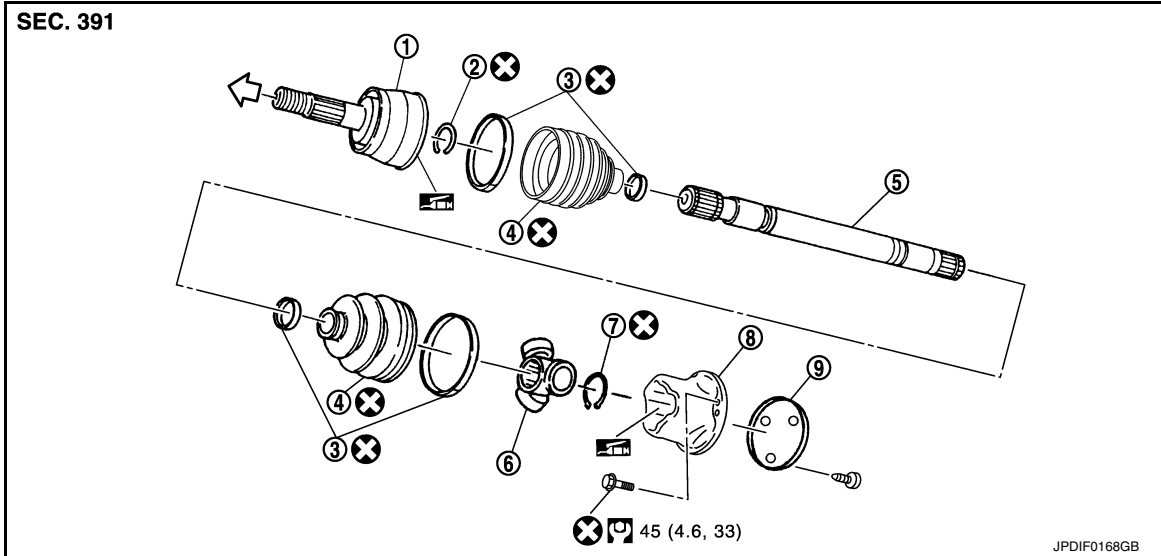

- | | | |
|-----------------------|------------------|--------------------|
| 1. Joint sub-assembly | 2. Circular clip | 3. Boot band |
| 4. Boot | 5. Shaft | 6. Spider assembly |
| 7. Snap ring | 8. Housing | 9. Plug |

← Wheel side

: NISSAN genuine grease or an equivalent.

: N·m (kg-m, ft-lb)

: Always replace after every disassembly.

VK50VE

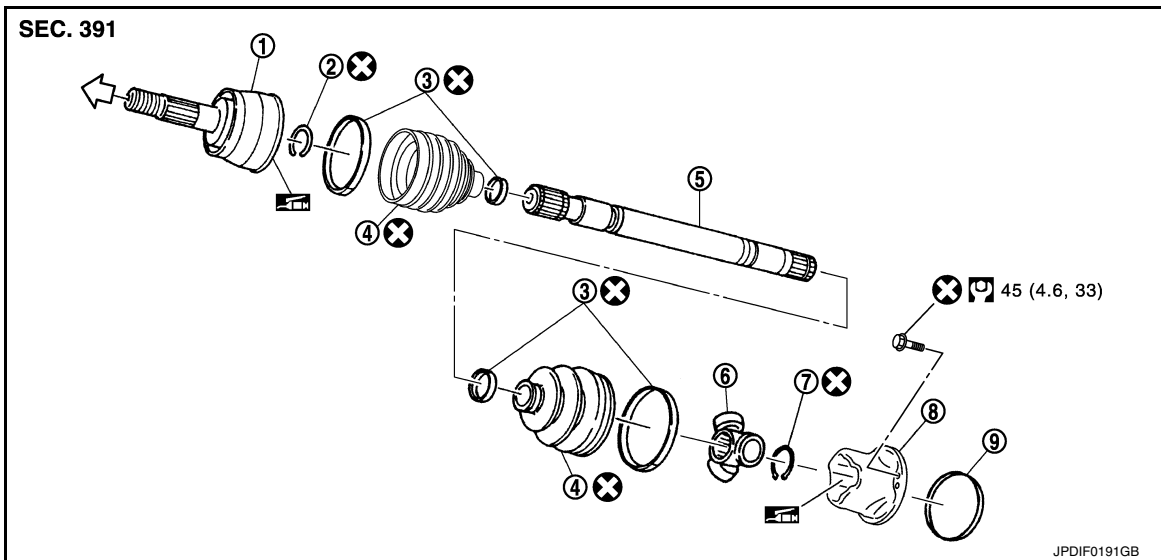

- | | | |
|-----------------------|------------------|--------------------|
| 1. Joint sub-assembly | 2. Circular clip | 3. Boot band |
| 4. Boot | 5. Shaft | 6. Spider assembly |
| 7. Snap ring | 8. Housing | 9. Plug |

← Wheel side

A
B
C
FAX
E
F
G
H
I
J
K
L
M
N
O
P

FRONT DRIVE SHAFT

[AWD]

< REMOVAL AND INSTALLATION >

: NISSAN genuine grease or an equivalent.

: N·m (kg-m, ft-lb)

: Always replace after every disassembly.

RIGHT SIDE

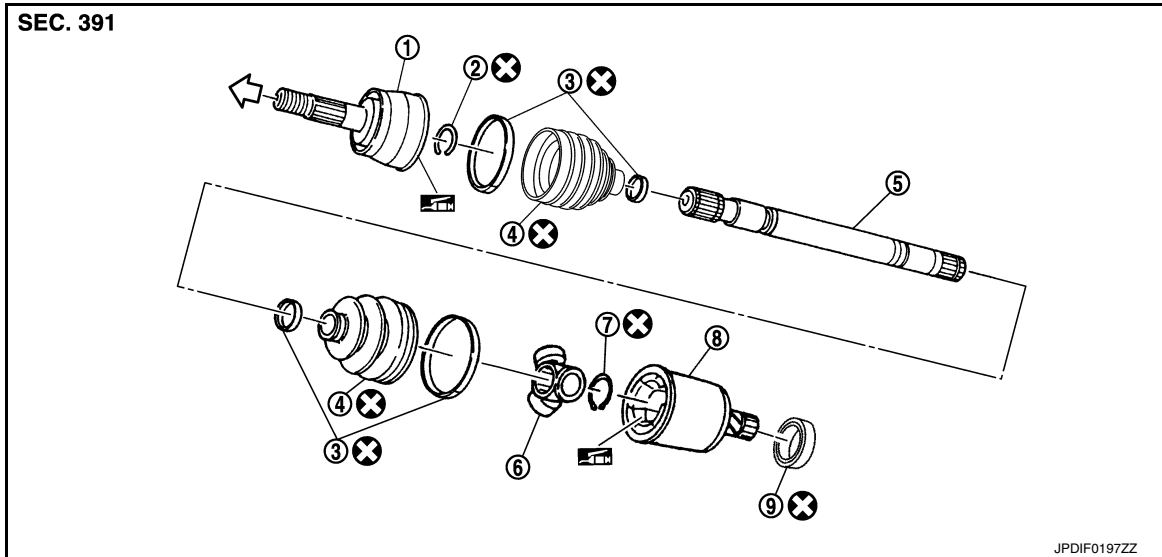

1. Joint sub-assembly

2. Circular clip

3. Boot band

4. Boot

5. Shaft

6. Spider assembly

7. Snap ring

8. Housing

9. Dust shield

: Wheel side

: NISSAN genuine grease or an equivalent.

: N·m (kg-m, ft-lb)

: Always replace after every disassembly.

LEFT SIDE

LEFT SIDE : Removal and Installation

INFOID:000000010578208

REMOVAL

1. Remove tires with power tool.
2. Remove wheel sensor and sensor harness. Refer to [BRC-133, "FRONT WHEEL SENSOR : Exploded View"](#).
CAUTION:
Never pull on wheel sensor harness.
3. Remove brake hose bracket. Refer to [BR-22, "FRONT : Exploded View"](#).
4. Remove caliper assembly mounting bolts with power tool. Hang caliper assembly in a place where it will not interfere with work. Refer to [BR-45, "BRAKE CALIPER ASSEMBLY \(2 PISTON TYPE\) : Exploded View"](#) (2 piston type), [BR-49, "BRAKE CALIPER ASSEMBLY \(4 PISTON TYPE\) : Exploded View"](#) (4 piston type).
CAUTION:
Never depress brake pedal while brake caliper is removed.
5. Remove disc rotor. Refer to [BR-46, "BRAKE CALIPER ASSEMBLY \(2 PISTON TYPE\) : Removal and Installation"](#) (2 piston type), [BR-50, "BRAKE CALIPER ASSEMBLY \(4 PISTON TYPE\) : Removal and Installation"](#) (4 piston type).
6. Remove cotter pin, and then loosen wheel hub lock nut with a power tool. Refer to [FAX-17, "Exploded View"](#).

FRONT DRIVE SHAFT

[AWD]

< REMOVAL AND INSTALLATION >

7. Patch wheel hub lock nut with a piece of wood. Hammer the wood to disengage wheel hub and bearing assembly from drive shaft.

CAUTION:

- Never place drive shaft joint at an extreme angle. Also be careful not to overextend slide joint.
- Never allow drive shaft to hang down without support for joint sub-assembly, shaft and the other parts.

NOTE:

Use suitable puller if wheel hub and drive shaft cannot be separated even after performing the above procedure.

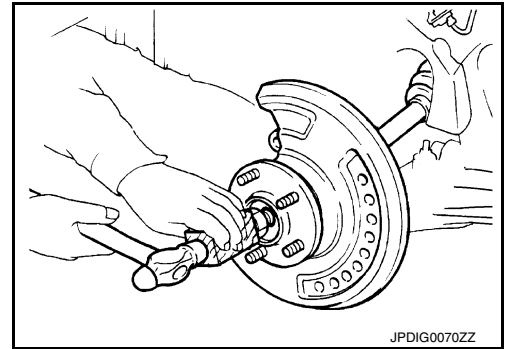

8. Remove wheel hub lock nut.
9. Remove steering outer socket. Refer to [ST-26, "Exploded View"](#).
10. Separate upper link from steering knuckle. Refer to [FAX-17, "Exploded View"](#).
11. Remove drive shaft from wheel hub and bearing assembly.
12. Remove shock absorber from vehicle with power tool. Refer to [FSU-30, "Exploded View"](#).
13. Remove under cover with power tool. Refer to [EXT-31, "Exploded View"](#).
14. Remove mounting bolts, and then remove drive shaft from the front final drive assembly.

INSTALLATION

Note the following, and install in the reverse order of removal.

- Install drive shaft using tightening torque of wheel hub lock nut. Refer to [FAX-17, "Exploded View"](#).

CAUTION:

Be sure to use torque wrench to tighten the wheel hub lock nut. Never use a power tool.

- Never reuse cotter pin.

RIGHT SIDE

RIGHT SIDE : Removal and Installation

INFOID:000000010578209

REMOVAL

1. Remove tires with power tool.
 2. Remove wheel sensor and sensor harness. Refer to [BRC-133, "FRONT WHEEL SENSOR : Exploded View"](#).
- ### CAUTION:
- Never pull on wheel sensor harness.
3. Remove brake hose bracket. Refer to [BR-22, "FRONT : Exploded View"](#).
 4. Remove caliper assembly mounting bolts with power tool. Hang caliper assembly in a place where it will not interfere with work. Refer to [BR-45, "BRAKE CALIPER ASSEMBLY \(2 PISTON TYPE\) : Exploded View"](#) (2 piston type), [BR-49, "BRAKE CALIPER ASSEMBLY \(4 PISTON TYPE\) : Exploded View"](#) (4 piston type).
- ### CAUTION:
- Never depress brake pedal while brake caliper is removed.
5. Remove disc rotor. Refer to [BR-46, "BRAKE CALIPER ASSEMBLY \(2 PISTON TYPE\) : Removal and Installation"](#) (2 piston type), [BR-50, "BRAKE CALIPER ASSEMBLY \(4 PISTON TYPE\) : Removal and Installation"](#) (4 piston type).
 6. Remove cotter pin, and then loosen wheel hub lock nut with a power tool.
 7. Patch wheel hub lock nut with a piece of wood. Hammer the wood to disengage wheel hub and bearing assembly from drive shaft.

CAUTION:

- Never place drive shaft joint at an extreme angle. Also be careful not to overextend slide joint.
- Never allow drive shaft to hang down without support for joint sub-assembly, shaft and the other parts.

NOTE:

Use suitable puller if wheel hub and drive shaft cannot be separated even after performing the above procedure.

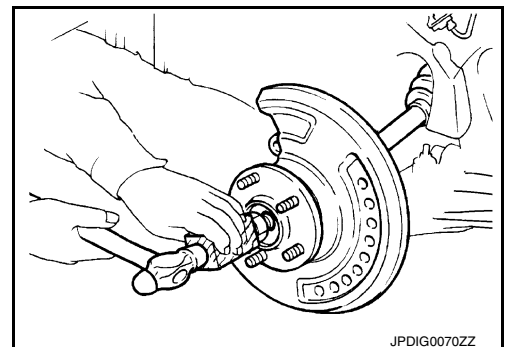

FRONT DRIVE SHAFT

[AWD]

< REMOVAL AND INSTALLATION >

8. Remove wheel hub lock nut.
9. Remove wheel hub and bearing assembly from steering knuckle. Refer to [FAX-17, "Exploded View"](#).
10. Remove fender protector. Refer to [EXT-25, "FENDER PROTECTOR : Exploded View"](#).
11. Remove drive shaft from front final drive assembly using the drive shaft attachment (A) [SST: KV40107500 (-)] and a sliding hammer (commercial service tool) (B) while inserting tip of the drive shaft attachment between housing and front final drive assembly.

CAUTION:

Never place drive shaft joint at an extreme angle when removing drive shaft. Also be careful not to overextend slide joint.

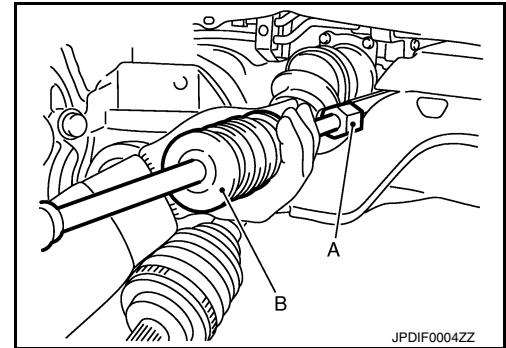

INSTALLATION

Note the following, and install in the reverse order of removal.

CAUTION:

Always replace final drive oil seal with new one when installing drive shaft. Refer to [DLN-154, "RIGHT SIDE : Exploded View"](#)

- Place the protector (A) [SST: KV38107900 (-)] onto final drive to prevent damage to the oil seal while inserting drive shaft. Slide drive shaft sliding joint and tap with a hammer to install securely.

CAUTION:

Check that circular clip is completely engaged.

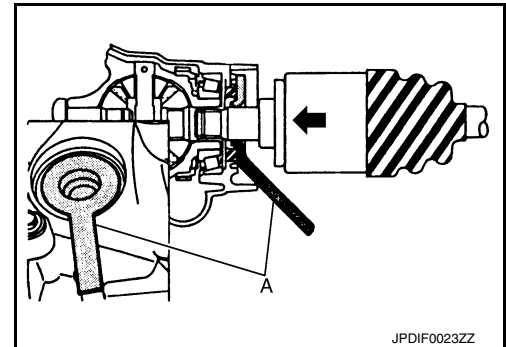

WHEEL SIDE

WHEEL SIDE : Disassembly and Assembly

INFOID:000000010578210

DISASSEMBLY

1. Fix shaft with a vise.
CAUTION:
Protect shaft when fixing with a vise using aluminum or copper plates.
2. Remove boot bands, and then remove boot from joint sub-assembly.
3. Screw drive shaft puller (commercial service tool) (A) 30 mm (1.18 in) or more into the thread of joint sub-assembly, and pull joint sub-assembly from shaft.

CAUTION:

- If joint sub-assembly cannot be removed after five or more unsuccessful attempts, replace shaft and joint sub-assembly as a set.
- Align sliding hammer and drive shaft and remove them by pulling directory.

4. Remove circular clip from shaft.
5. Remove boot from shaft.
6. Clean old grease on joint sub-assembly with paper waste while rotating ball cage.

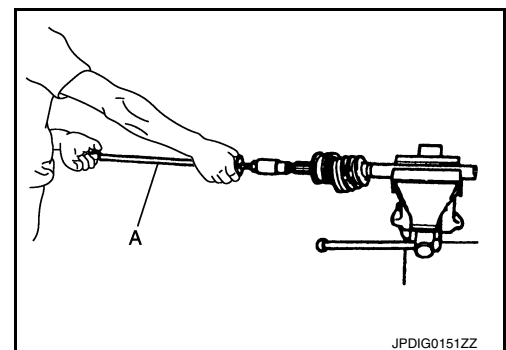

ASSEMBLY

1. Clean the old grease on joint sub-assembly with paper waste.

FRONT DRIVE SHAFT

[AWD]

< REMOVAL AND INSTALLATION >

2. Fill serration slot joint sub-assembly (1) with NISSAN genuine grease or equivalent until the serration slot and ball groove become full to the brim.

CAUTION:

After applying grease, use a shop cloth to wipe off old grease that has oozed out.

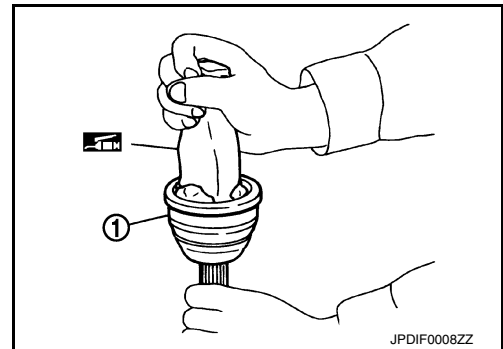

3. Install boot and boot bands to shaft.

CAUTION:

- Wrap serration on shaft with tape (A) to protect the boot from damage.
- Never reuse boot and boot band.

4. Remove the tape wrapped around the serration on shaft.
5. Position circular clip on groove at the shaft edge.

CAUTION:

Never reuse circular clip.

NOTE:

Drive joint inserter is recommended when installing circular clip.

6. Align both center axes of the shaft edge and joint sub-assembly. Then assemble shaft with circular clip joint sub-assembly.
7. Install joint sub-assembly to shaft using plastic hammer.

CAUTION:

Confirm that joint sub-assembly is correctly engaged while rotating drive shaft.

8. Apply the specified amount of grease into the boot inside from large diameter side of boot.

Grease amount : Refer to [FAX-37, "Drive Shaft"](#).

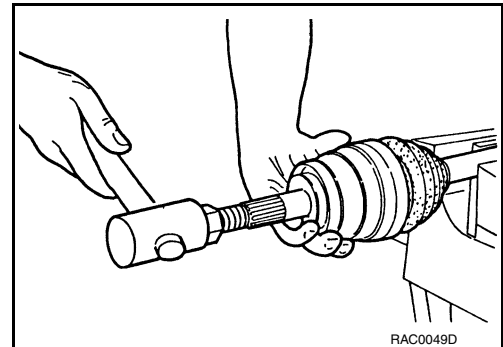
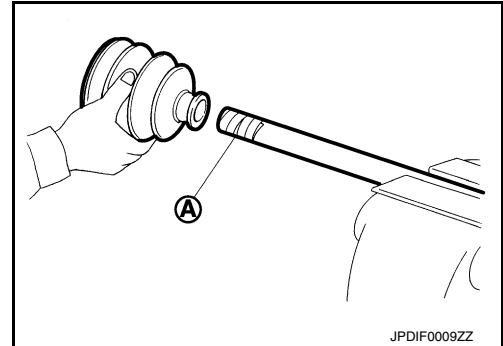

9. Install the boot securely into grooves (indicated by "*" marks) shown in the figure.

CAUTION:

If grease adheres to the boot mounting surface (indicated by "*" mark) on the shaft or joint sub-assembly, boot may come off. Remove all grease from the surface.

10. To prevent from the deformation of the boot, adjust the boot installation length (L) to the specified value shown below by inserting the suitable tool into inside of the boot from the large diameter side of the boot and discharging the inside air.

L : Refer to [FAX-37, "Drive Shaft"](#).

CAUTION:

- If the boot mounting length is outside the standard, it may cause breakage in the boot.
- Be careful not to touch the inside of the boot with a tip of tool.

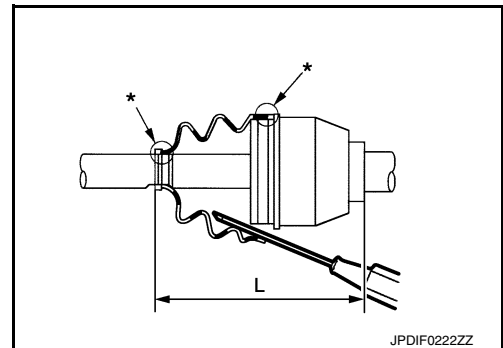

FRONT DRIVE SHAFT

[AWD]

< REMOVAL AND INSTALLATION >

11. Secure the ends of the boot with boot bands using the boot band crimping tool (A) [SST: KV40107300 (-)].

CAUTION:

Never reuse boot band.

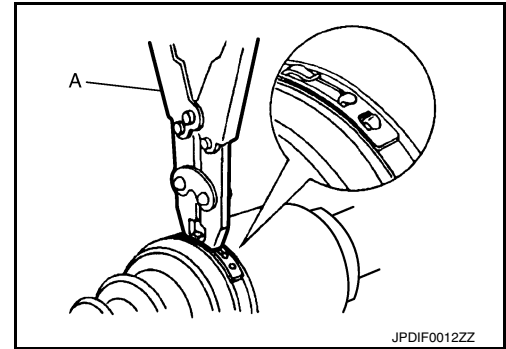

NOTE:

Secure boot band so that dimension (A) meets the specification as shown in the figure.

A : 7.0 mm (0.276 in) or less

12. Secure joint sub-assembly and shaft, and then make sure that they are in the correct position when rotating boot. Install them with boot band when boot installation positions become incorrect.

CAUTION:

Never reuse boot band.

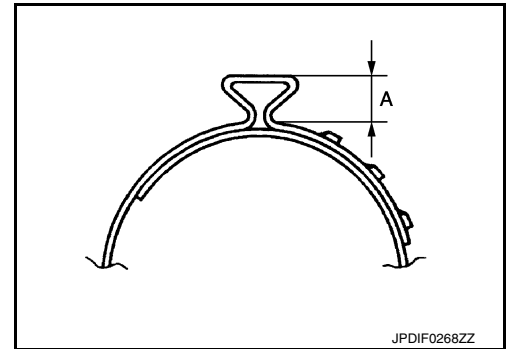

FINAL DRIVE SIDE

FINAL DRIVE SIDE : Disassembly and Assembly

INFOID:000000010578211

DISASSEMBLY

1. Fix shaft with a vise.

CAUTION:

Protect shaft when fixing with a vise using aluminum or copper plates.

2. Remove boot bands, and then remove boot from housing.
3. If plug needs to be removed, remove with following procedure. (Left side)
 - Remove screw and remove plug. (VQ37VHR)
 - Remove with plastic hammer. (VK50VE)
4. Remove dust shield. (Right side)
5. Put matching marks on housing and shaft, and then pull out housing from shaft.

CAUTION:

Use paint or similar substance for matching marks. Never scratch the surfaces.

6. Put matching marks (A) on the spider assembly and shaft.

CAUTION:

Use paint or similar substance for matching marks. Never scratch the surfaces.

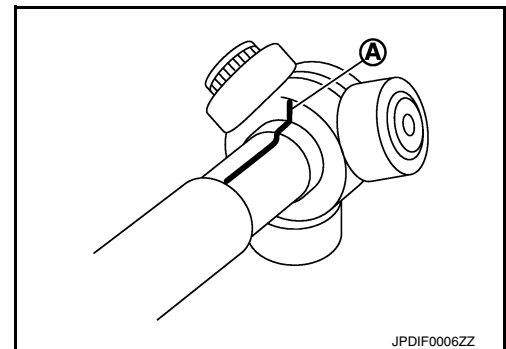

FRONT DRIVE SHAFT

[AWD]

< REMOVAL AND INSTALLATION >

7. Remove snap ring (1), and then remove spider assembly from the shaft.
8. Remove boot from the shaft.

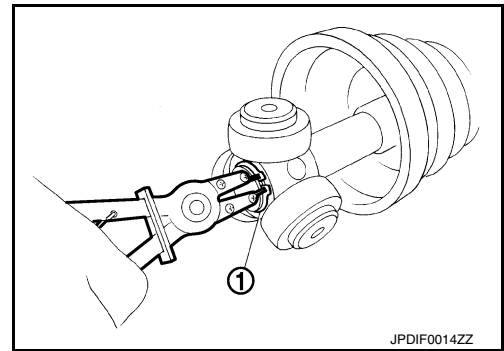

ASSEMBLY

1. Clean old grease on housing with paper waste.
2. Plug has been removed, install with the following procedure. (Left side)
 - Install plug (1) to housing (2) with screw. (VQ37VHR)

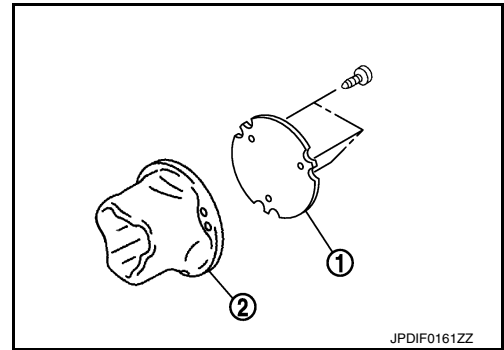

- Install plug (1) to housing with drift. (VK50VE)

← : Press

A : Drift [SST: KV38100500 (—)]

B : Drift [SST: KV38102200 (—)]

3. Install dust shield to housing. (Right side)

CAUTION:

Never reuse dust shield.

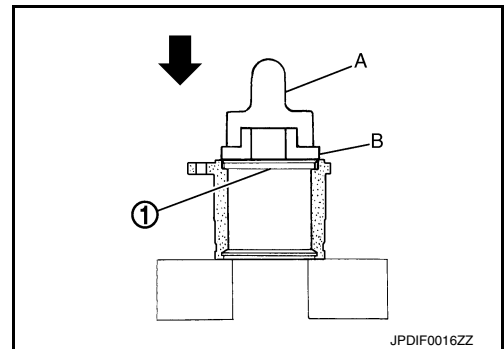

4. Install boot and boot bands to shaft.

CAUTION:

- **Wrap serration on shaft with tape (A) to protect boot from damage.**

- **Never reuse boot and boot band.**

5. Remove the tape wrapped around the serration on shaft.

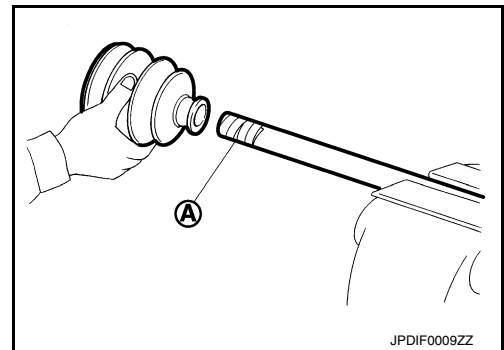

FRONT DRIVE SHAFT

[AWD]

< REMOVAL AND INSTALLATION >

6. Install the spider assembly (1), align it with the matching marks (A) on the shaft (2) during the removal, and direct the serration mounting surface (B) to the shaft.

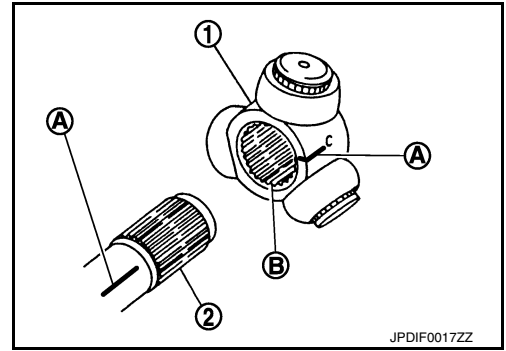

7. Secure spider assembly onto shaft with snap ring (1).
CAUTION:
Never reuse snap ring.
8. Apply the appropriate amount of grease to spider assembly and sliding surface.
9. Assemble the housing onto spider assembly, and apply the specified amount grease.

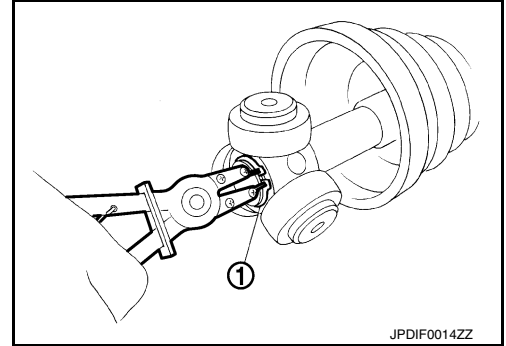

Grease amount : Refer to [FAX-37, "Drive Shaft"](#).

10. Align matching marks painted when housing was removed.
11. Install the boot securely into grooves (indicated by "*" marks) shown in the figure.

CAUTION:

If grease adheres to the boot mounting surface (indicated by "*" mark) on shaft or housing, boot may come off. Remove all grease from the surface.

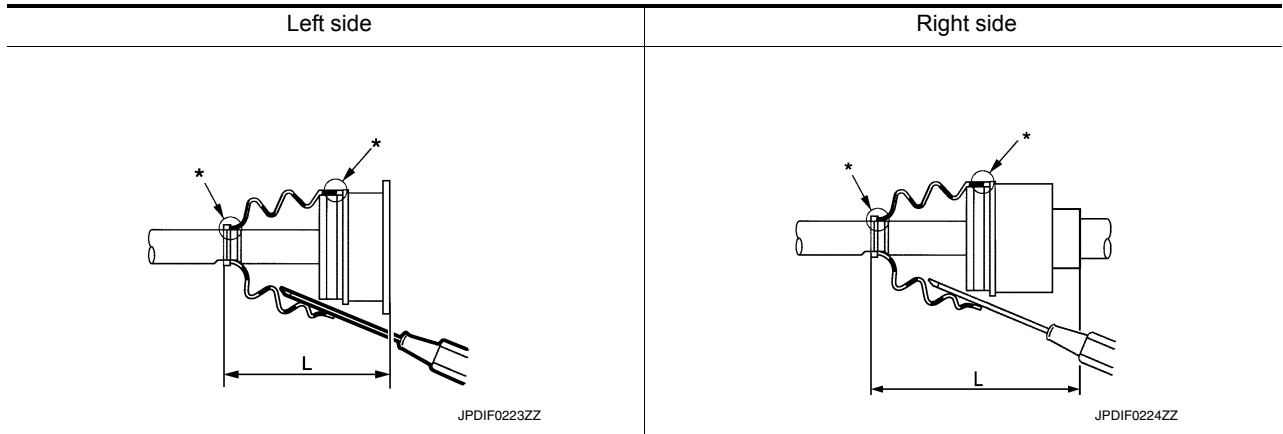

12. To prevent from deformation of the boot, adjust the boot installation length (L) to the value shown below by inserting the suitable tool into the inside of boot from the large diameter side of boot and discharging inside air.

L : Refer to [FAX-37, "Drive Shaft"](#).

CAUTION:

- If the boot installation length is outside the standard, it may cause breakage in boot.
- Be careful not to touch the inside of the boot with the tip of tool.

13. Install boot bands securely.

CAUTION:

Never reuse boot band.

FRONT DRIVE SHAFT

[AWD]

< REMOVAL AND INSTALLATION >

- a. For one-touch clamp band. (Left side)
 - i. Install boot bands securely as shown in the figure.

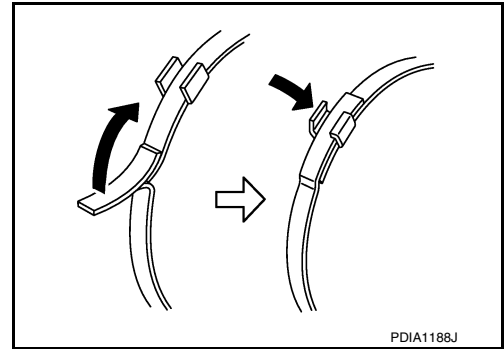

- b. For low profile type band. (Right side)
 - i. Put boot band in the groove on drive shaft boot. Then fit pawls (←) into holes to temporary installation.
 - NOTE:**
For the large diameter side, fit projection (A) and guide slit (B) at first.

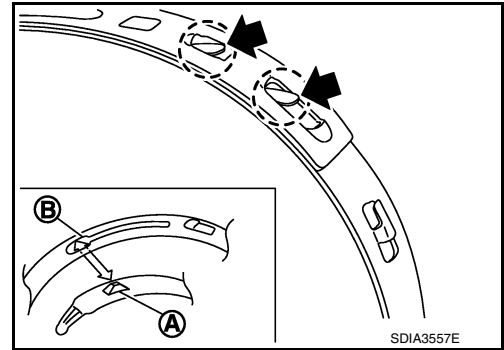

- ii. Pinch projection on the band with suitable pliers to tighten band.
 - iii. Insert tip of band below end of the pawl.
- 14. Secure housing and shaft, and then make sure that they are in the correct position when rotating boot. Install them with boot band when the mounting positions become incorrect.
- 15. Install dust shield to housing. (right side)
 - CAUTION:**
Never reuse dust cover.

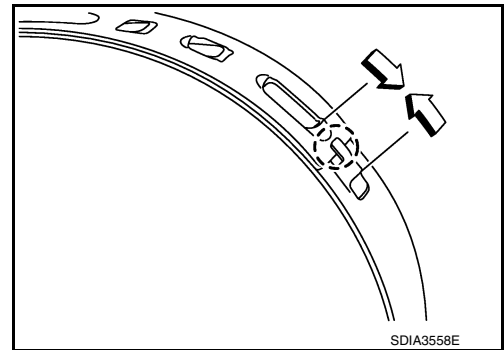

Inspection

INFOID:0000000010578212

INSPECTION AFTER REMOVAL

- Move joint up/down, left/right, and in the axial directions. Check for motion that is not smooth and for significant looseness.
- Check boot for cracks, damage, and leakage of grease.
- Disassemble drive shaft and exchange malfunctioning part if there is a non-standard condition.

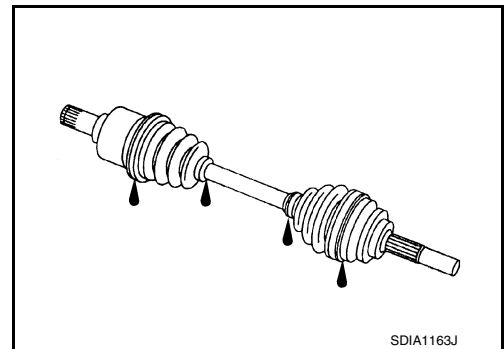

INSPECTION AFTER DISASSEMBLY

Shaft

Check shaft for runout, cracks, or other damage. Replace it if necessary.

Joint Sub-Assembly (Wheel Side)

A
B
C
FAX
E
F
G
H
I
J
K
L
M
N
O
P

FRONT DRIVE SHAFT

< REMOVAL AND INSTALLATION >

[AWD]

Check the following items, replace the parts if necessary.

- Joint sub-assembly for rough rotation and excessive axial looseness.
 - The inside of the joint sub-assembly for entry of foreign material.
 - Joint sub-assembly for compression scars, cracks, and fractures inside of joint sub-assembly.
- Replace joint sub-assembly if there are any non-standard conditions of components.

Housing and Spider assembly (Final Drive side)

Replace housing and spider assembly if there is scratching or wear of housing roller contact surface or spider roller contact surface.

NOTE:

Housing and spider assembly are used in a set.

SERVICE DATA AND SPECIFICATIONS (SDS)

< SERVICE DATA AND SPECIFICATIONS (SDS)

[AWD]

SERVICE DATA AND SPECIFICATIONS (SDS)

SERVICE DATA AND SPECIFICATIONS (SDS)

Wheel Bearing

INFOID:0000000010578213

Item	Standard
Axial end play	0.05 mm (0.002 in) or less

Drive Shaft

INFOID:0000000010578214

VQ37VHR

Item		Standard	
		Left side	Right side
Grease quantity	Wheel side	77 – 97 g (2.72 – 3.42 oz)	
	Final drive side	95 – 105 g (3.36 – 3.70 oz)	113 – 123 g (3.99 – 4.33 oz)
Boots installed length	Wheel side	136 mm (5.35 in)	
	Final drive side	152 mm (5.98 in)	158.6 mm (6.24 in)

VK50VE

Item		Standard	
		Left side	Right side
Grease quantity	Wheel side	77 – 97 g (2.72 – 3.42 oz)	
	Final drive side	95 – 105 g (3.36 – 3.70 oz)	113 – 123 g (3.99 – 4.33 oz)
Boots installed length	Wheel side	136 mm (5.35 in)	
	Final drive side	149.5 mm (5.89 in)	158.6 mm (6.24 in)

A
B
C
FAX
E
F
G
H
I
J
K
L
M
N
O
P