

SECTION **SE**
SEAT

A
B
C
D
E
F
G
H
I
SE
K
L
M
N
O
P

CONTENTS

BASIC INSPECTION	5	HEATED SEAT SWITCH	16
DIAGNOSIS AND REPAIR WORK FLOW	5	HEATED SEAT SWITCH : Diagnosis Procedure	16
Work Flow	5	CLIMATE CONTROLLED SEAT CONTROL UNIT	17
SYSTEM DESCRIPTION	6	CLIMATE CONTROLLED SEAT CONTROL UNIT	
POWER SEAT	6	: Diagnosis Procedure	17
System Description	6	CLIMATE CONTROLLED SEAT CONTROL UNIT	
Component Parts Location	6	: Component Inspection	20
Component Description	7	CLIMATE CONTROLLED SEAT SWITCH	22
HEATED SEAT	8	Description	22
System Diagram	8	Component Function Check	22
System Description	8	Diagnosis Procedure	22
Component Parts Location	9	Component Inspection	24
Component Description	9	SEATBACK THERMAL ELECTRIC DEVICE ...	25
SIDE SUPPORT	10	Description	25
System Description	10	Component Function Check	25
Component Parts Location	10	Diagnosis Procedure	25
Component Description	10	SEATBACK THERMAL ELECTRIC DEVICE	
LUMBAR SUPPORT	11	SENSOR	27
System Description	11	Description	27
Component Parts Location	11	Diagnosis Procedure	27
Component Description	11	SEAT CUSHION THERMAL ELECTRIC DE-	
CLIMATE CONTROLLED SEAT	12	VICE	29
System Diagram	12	Description	29
System Description	12	Component Function Check	29
Component Parts Location	13	Diagnosis Procedure	29
Component Description	13	SEAT CUSHION THERMAL ELECTRIC DE-	
DTC/CIRCUIT DIAGNOSIS	14	VICE SENSOR	31
POWER SUPPLY AND GROUND CIRCUIT	14	Description	31
HEATED SEAT CONTROL UNIT	14	Diagnosis Procedure	31
HEATED SEAT CONTROL UNIT : Diagnosis Pro-		CLIMATE CONTROLLED SEAT BLOWER	
cedure	14	MOTOR	33
		Description	33
		Component Function Check	33
		Diagnosis Procedure	33

CLIMATE CONTROLLED SEAT SWITCH INDICATOR	36	SEATBACK HEATER	55
Description	36	DRIVER SIDE	55
Component Function Check	36	DRIVER SIDE : Description	55
Diagnosis Procedure	36	DRIVER SIDE : Component Function Check	55
Component Inspection	37	DRIVER SIDE : Diagnosis Procedure	55
CLIMATE CONTROLLED SEAT BLOWER FILTER	39	PASSENGER SIDE	55
Diagnosis Procedure	39	PASSENGER SIDE : Description	55
HEATED SEAT SWITCH	40	PASSENGER SIDE :	
DRIVER SIDE	40	Component Function Check	55
DRIVER SIDE : Description	40	PASSENGER SIDE : Diagnosis Procedure	55
DRIVER SIDE : Component Function Check	40	HEATED SEAT SWITCH INDICATOR	57
DRIVER SIDE : Diagnosis Procedure	40	DRIVER SIDE	57
DRIVER SIDE : Component Inspection	41	DRIVER SIDE : Description	57
PASSENGER SIDE	41	DRIVER SIDE : Component Function Check	57
PASSENGER SIDE : Description	41	DRIVER SIDE : Diagnosis Procedure	57
PASSENGER SIDE :		DRIVER SIDE : Component Inspection	57
Component Function Check	41	PASSENGER SIDE	58
PASSENGER SIDE : Diagnosis Procedure	41	PASSENGER SIDE : Description	58
PASSENGER SIDE : Component Inspection	42	PASSENGER SIDE :	
HEATED SEAT RELAY	44	Component Function Check	58
Description	44	PASSENGER SIDE : Diagnosis Procedure	58
Component Function Check	44	PASSENGER SIDE : Component Inspection	58
Diagnosis Procedure	44	POWER SEAT	60
Component Inspection	45	Wiring Diagram - POWER SEAT FOR DRIVER	
HEAT SENSOR	46	SIDE (WITHOUT AUTOMATIC DRIVE POSI-	
DRIVER SIDE	46	TIONER) -	60
DRIVER SIDE : Description	46	Wiring Diagram - POWER SEAT FOR PASSEN-	
DRIVER SIDE : Component Function Check	46	GER SIDE -	65
DRIVER SIDE : Diagnosis Procedure	46	SIDE SUPPORT	70
DRIVER SIDE : Component Inspection	47	Wiring Diagram - SIDE SUPPORT -	70
PASSENGER SIDE	48	LUMBAR SUPPORT	74
PASSENGER SIDE : Description	48	Wiring Diagram - LUMBAR SUPPORT -	74
PASSENGER SIDE : Component Function Check		ECU DIAGNOSIS INFORMATION	79
.....	48	CLIMATE CONTROLLED SEAT CONTROL	
PASSENGER SIDE : Diagnosis Procedure	48	UNIT	79
PASSENGER SIDE : Component Inspection	50	Reference Value	79
SEAT CUSHION HEATER	51	Wiring Diagram - CLIMATE CONTROLLED SEAT	
DRIVER SIDE	51	CONTROL SYSTEM -	81
DRIVER SIDE : Description	51	Fail-safe	89
DRIVER SIDE : Component Function Check	51	HEATED SEAT CONTROL UNIT	92
DRIVER SIDE : Diagnosis Procedure	51	Reference Value	92
DRIVER SIDE : Component Inspection	52	Wiring Diagram - HEATED SEAT SYSTEM -	93
PASSENGER SIDE	52	SYMPTOM DIAGNOSIS	101
PASSENGER SIDE : Description	52	CLIMATE CONTROLLED SEAT DOES NOT	
PASSENGER SIDE :		OPERATE.	101
Component Function Check	52	BOTH SIDES	101
PASSENGER SIDE : Diagnosis Procedure	52	BOTH SIDES : Diagnosis Procedure	101
PASSENGER SIDE : Component Inspection	54	DRIVER SIDE	101

DRIVER SIDE : Diagnosis Procedure	101	Work Flow	112	
PASSENGER SIDE	101	Inspection Procedure	114	A
PASSENGER SIDE : Diagnosis Procedure	101	Diagnostic Worksheet	116	
CLIMATE CONTROLLED SEAT BLOWER MOTOR SPEED CANNOT ADJUST.	103	PRECAUTION	118	B
Diagnosis Procedure	103	PRECAUTIONS	118	
CLIMATE CONTROLLED SEAT DOES NOT OPERATES WHEN SWITCH IS DONE IN HEAT OR COOL.	104	Precaution for Supplemental Restraint System (SRS) "AIR BAG" and "SEAT BELT PRE-TEN- SIONER"	118	C
Diagnosis Procedure	104	Precautions for Removing Battery Terminal	118	
WHEN THE CLIMATE CONTROLLED SEAT SWITCH IS TURNED ON, OPERATION STOP AT NOSE.	105	Service Notice	118	D
Diagnosis Procedure	105	Precaution for Work	119	
SEAT SWITCH INDICATOR DOES NOT OP- ERATE IN HEAT OR COOL POSITION	106	PREPARATION	120	E
Diagnosis Procedure	106	PREPARATION	120	
HEATED SEAT DOES NOT OPERATE	107	Special Service Tool	120	F
BOTH SIDES	107	Commercial Service Tool	120	
BOTH SIDES : Diagnosis Procedure	107	CLIP LIST	121	G
DRIVER SIDE	107	Clip List	121	
DRIVER SIDE : Diagnosis Procedure	107	REMOVAL AND INSTALLATION	122	H
PASSENGER SIDE	108	FRONT SEAT	122	
PASSENGER SIDE : Diagnosis Procedure	108	Exploded View	122	I
SEATBACK HEATER ONLY DOES NOT OP- ERATE	109	Removal and Installation	125	
DRIVER SIDE	109	Disassembly and Assembly	126	
DRIVER SIDE : Diagnosis Procedure	109	REAR SEAT	135	
PASSENGER SIDE	109	Exploded View	135	
PASSENGER SIDE : Diagnosis Procedure	109	Removal and Installation	136	
CANNOT ADJUST HEATED SEAT TEMPER- ATURE	110	Disassembly and Assembly	137	SE
DRIVER SIDE	110	SEATBACK CONTROL CABLE	143	
DRIVER SIDE : Diagnosis Procedure	110	Exploded View	143	K
PASSENGER SIDE	110	Removal and Installation	143	
PASSENGER SIDE : Diagnosis Procedure	110	POWER SEAT SWITCH	145	L
HEATED SEAT SWITCH INDICATOR DOES NOT TURN ON	111	Exploded View	145	
DRIVER SIDE	111	Removal and Installation	145	
DRIVER SIDE : Diagnosis Procedure	111	LUMBAR SUPPORT SWITCH	146	M
PASSENGER SIDE	111	Exploded View	146	
PASSENGER SIDE : Diagnosis Procedure	111	Removal and Installation	146	
SQUEAK AND RATTLE TROUBLE DIAG- NOSES	112	SIDE SUPPORT SWITCH	147	N
		Removal and Installation	147	
		CLIMATE CONTROLLED SEAT SWITCH	148	O
		Exploded View	148	
		Removal and Installation	148	
		CLIMATE CONTROLLED SEAT BLOWER FILTER	149	P
		Exploded View	149	
		Removal and Installation	149	
		HEATED SEAT CONTROL UNIT	150	
		Exploded View	150	
		Removal and Installation	150	

HEATED SEAT SWITCH	151	Removal and Installation	151
Exploded View	151		

DIAGNOSIS AND REPAIR WORK FLOW

< BASIC INSPECTION >

BASIC INSPECTION

DIAGNOSIS AND REPAIR WORK FLOW

Work Flow

INFOID:0000000010584469

DETAILED FLOW

1.OBTAIN INFORMATION ABOUT SYMPTOM

Interview the customer to obtain as much malfunction information (conditions and environment when the malfunction occurred) as possible when the customer brings the vehicle in.

>> GO TO 2.

2.REPRODUCE THE MALFUNCTION INFORMATION

Check the malfunction on the vehicle that the customer describes.
Inspect the relation of the symptoms and the condition when the symptoms occur.

>> GO TO 3.

3.IDENTIFY THE MALFUNCTIONING SYSTEM WITH "SYMPTOM DIAGNOSIS"

Use "Symptom diagnosis" from the symptom inspection result in step 2 and then identify where to start performing the diagnosis based on possible causes and symptoms.

>> GO TO 4.

4.IDENTIFY THE MALFUNCTIONING PARTS WITH "DTC/CIRCUIT DIAGNOSIS"

Perform the diagnosis with "DTC/CIRCUIT DIAGNOSIS" of the applicable system.

>> GO TO 5.

5.REPAIR OR REPLACE THE MALFUNCTIONING PARTS

Repair or replace the specified malfunctioning parts.

>> GO TO 6.

6.FINAL CHECK

Check that malfunctions are not reproduced when obtaining the malfunction information from the customer, referring to the symptom inspection result in step 2.

Are the malfunctions corrected?

YES >> INSPECTION END

NO >> GO TO 3.

A
B
C
D
E
F
G
H
I
SE
K
L
M
N
O
P

POWER SEAT

< SYSTEM DESCRIPTION >

SYSTEM DESCRIPTION

POWER SEAT

System Description

INFOID:0000000010584470

BCM can operate regardless of the ignition switch position, because battery power is supplied at all times to power seat switch.

SLIDING OPERATION

While operating the sliding switch located in power seat switch, sliding motor operates and makes the seat front and back position adjustment possible.

RECLINING OPERATION

While operating the reclining switch located in power seat switch, reclining motor operates and makes the seat back forward and backward position adjustment possible.

LIFTING OPERATION

While operating the lifting switch located in power seat switch, lifting motor operates and makes the seat cushion up and down position adjustment possible.

Component Parts Location

INFOID:0000000010584471

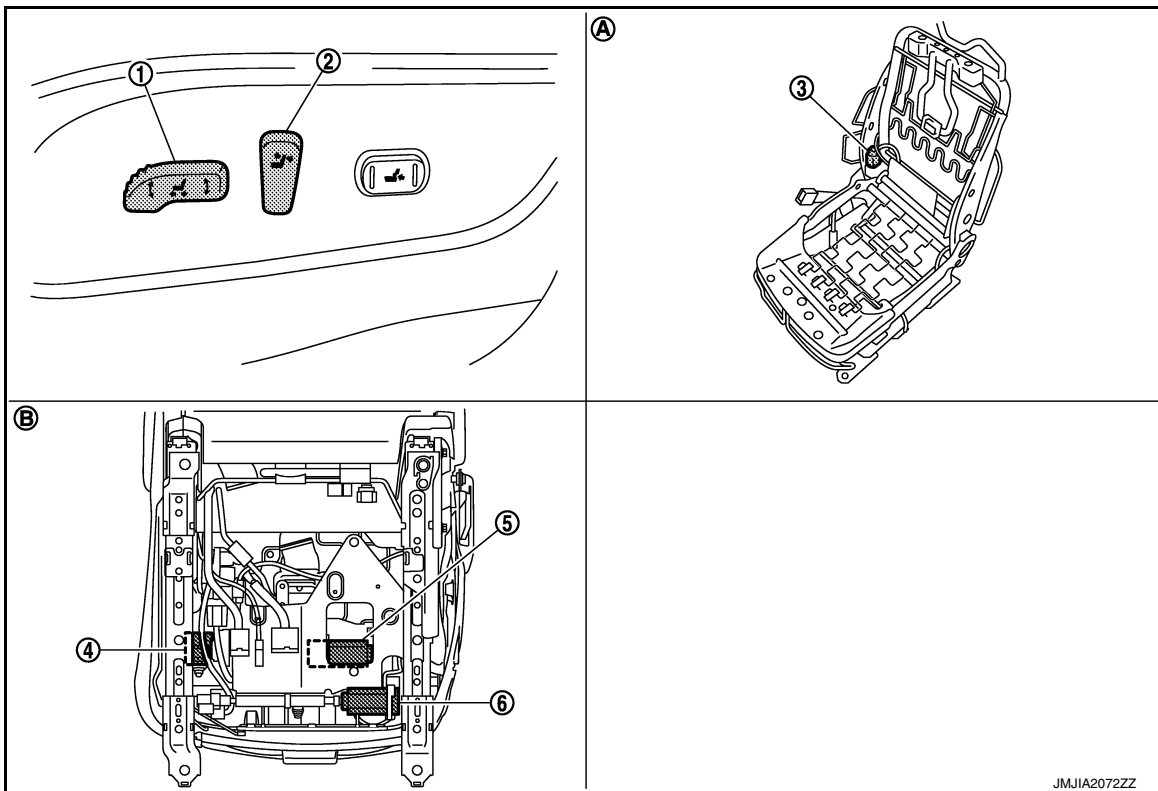

- | | | |
|--|---|---------------------------------------|
| 1. Sliding switch and lifting switch (driver side) B414 | 2. Reclining switch (driver side) B414 | 3. Reclining motor (driver side) B415 |
| 4. Lifting motor (rear) (driver side) B418 | 5. Lifting motor (front) (driver side) B417 | 6. Sliding motor (driver side) B416 |
| A. View with seat cushion pad and seat back pad removed. | B. Backside of seat cushion | |

POWER SEAT

< SYSTEM DESCRIPTION >

Component Description

INFOID:000000010584472

Item	Function
BCM	Supplies at all times the power received from battery to power seat switch
Power seat switch	Built-in reclining switch, sliding switch and lifting switch, and controls the power supplied to each motor
Reclining motor	With the power supplied from power seat switch, operates forward and backward movement of seatback
Sliding motor	With the power supplied from power seat switch, operates forward and backward slide of seat
Lifting motor (front/rear)	With the power supplied from power seat switch, operates up and down movement of seat cushion

A

B

C

D

E

F

G

H

I

SE

K

L

M

N

O

P

HEATED SEAT

< SYSTEM DESCRIPTION >

HEATED SEAT

System Diagram

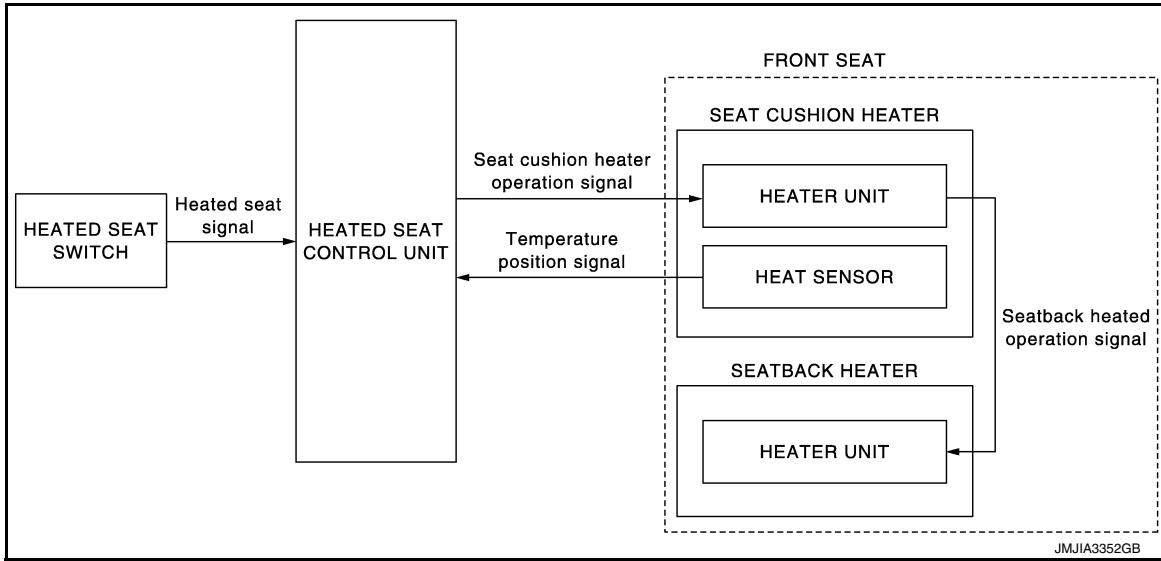

System Description

INFOID:000000010584474

- Heated seat is activated by heated seat switch while ignition switch is ON, and has the function to warm seat cushion and seatback.
- Heated seat equips the 6-stage temperature adjustment function that adjusts temperature by operating heated seat switch to the optimal position.
- Heated seat equips a thermostat in heater unit to prevent heater unit overheating.

OPERATION DESCRIPTION

- When operating heated seat switch to any position between 1 and 6 while ignition switch is ON, indicator illuminates, heated seat control unit supplies power supply to heater unit, and warms seat cushion and seatback.
- Heat sensor that is built in seat cushion heater detects seat cushion heater temperature and outputs to heated seat control unit.
- Heated seat control unit monitors the heated seat switch position and heater sensor temperature, and interrupts power supply to heater unit when the heat sensor temperature reaches preset temperature.
- Heated seat control unit adjusts temperature to preset temperature by supplying or interrupting power supply to heater unit.

HEATED SEAT

< SYSTEM DESCRIPTION >

Component Parts Location

INFOID:000000010584475

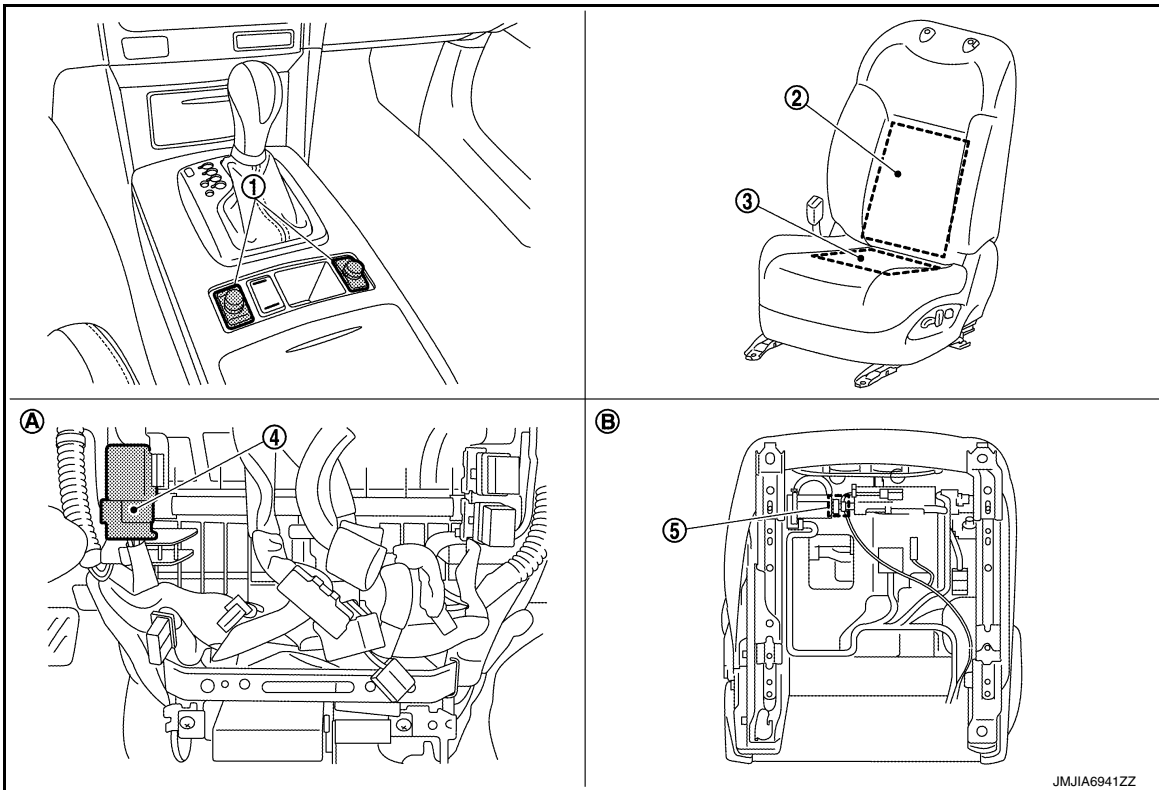

- | | | |
|-------------------------|-----------------------------|------------------------|
| 1. Heated seat switch | 2. Seatback heater | 3. Seat cushion heater |
| 4. Heated seat relay | 5. Heated seat control unit | |
| A. Behind cluster lid C | B. Backside of seat cushion | |

Component Description

INFOID:000000010584476

Item	Function
Heated seat switch	<ul style="list-style-type: none"> Adjusts heated seat temperature and deactivates heated seat Equips indicator that indicates the operating condition
Seat cushion heater	<ul style="list-style-type: none"> Warms seat cushion Contains heater sensor that outputs seat cushion heater temperature to heated seat control unit
Seatback heater	Warms seatback
Heated seat relay	Supplies power to the heated seat being controlled by ignition power supply
Heated seat control unit	Controls heated seat temperature and is independently placed in each seat cushion (driver seat and passenger seat)

A
B
C
D
E
F
G
H
I
SE
K
L
M
N
O
P

SIDE SUPPORT

< SYSTEM DESCRIPTION >

SIDE SUPPORT

System Description

INFOID:000000010584477

- While operating the side support switch, the pump located inside side support unit operates and adjusts the air pressure in seat cushion and seatback side support.
- It is possible to soften the side support by allowing some air to escape or by deflating the solenoid located inside side support.
- It is possible to adjust seat cushion and seatback differently while inflating or deflating solenoid located in side support unit.

Component Parts Location

INFOID:000000010584478

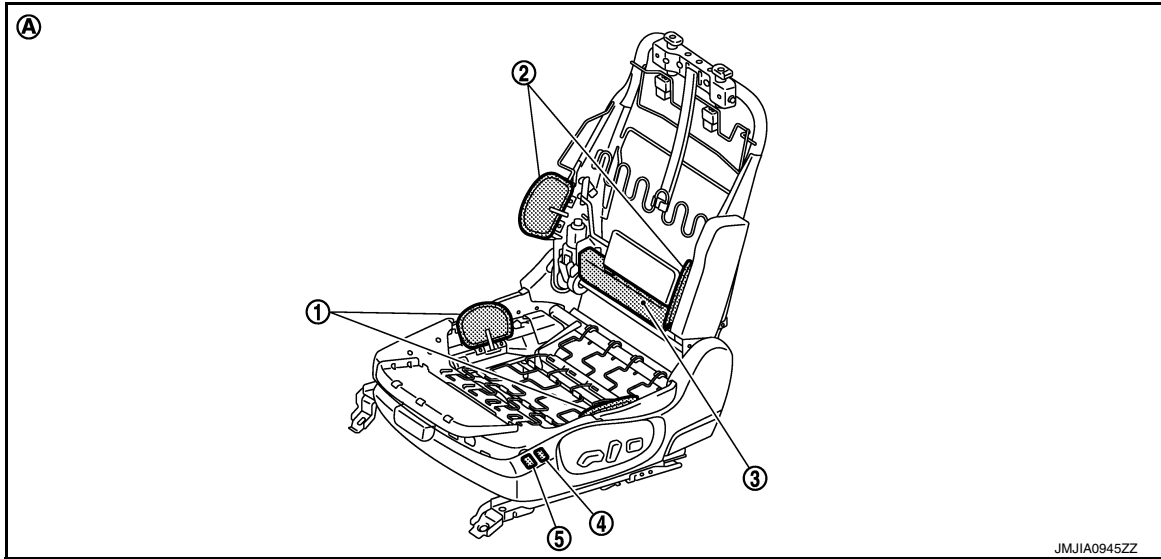

1. Side support (seat cushion)
(Side support unit B467)
2. Side support (seat back)
(Side support unit B467)
3. Side support unit B467
4. Side support switch (seat back side)
B464
5. Side support switch (cushion side)
B464

A. View with seat cushion pad and seat back pad removed.

Component Description

INFOID:000000010584479

Item	Function
Side support switch	With a built-in cushion side and seat back side, and controls the power supplied to pump and to each solenoid.
Side support unit	Built-in pump, pump relay, and solenoid, and operates when pressing ON/OFF on side support switch.

LUMBAR SUPPORT

< SYSTEM DESCRIPTION >

LUMBAR SUPPORT

System Description

INFOID:000000010584480

- Lumbar support can operate regardless of the ignition switch position because battery power is supplied to it at all times.
- While operating the lumbar support switch, lumbar support motor operates which allows forward and backward operation of seatback support.

Component Parts Location

INFOID:000000010584481

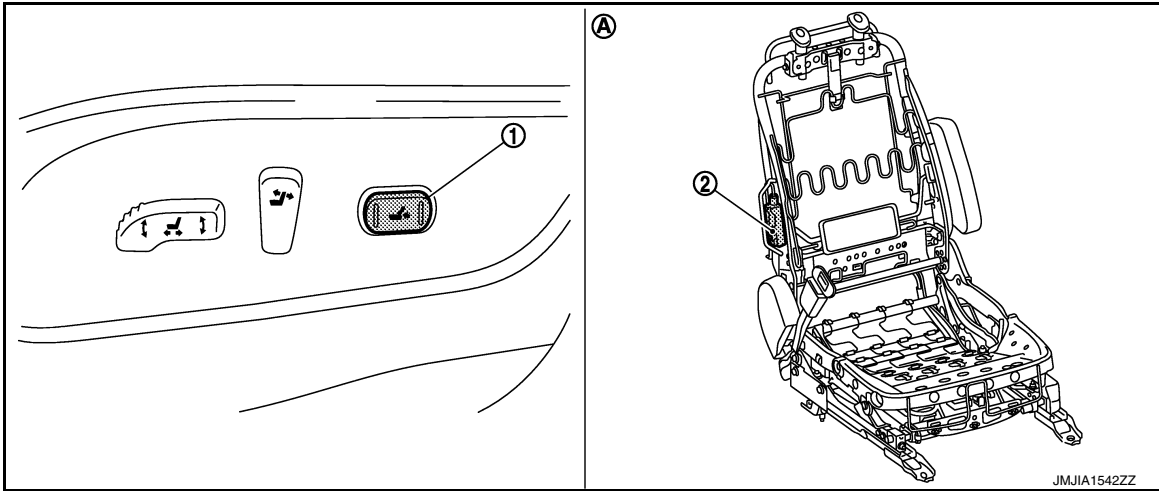

1. Lumbar support switch B457 2. Lumbar support motor B458
 A. View with seat back pad removed

Component Description

INFOID:000000010584482

Item	Function
Lumbar support switch	Controls the power supplied to lumbar support motor
Lumbar support motor	With the power supplied from lumbar support switch, operates forward and backward movement of seatback support device

A
B
C
D
E
F
G
H
I
SE
K
L
M
N
O
P

CLIMATE CONTROLLED SEAT

< SYSTEM DESCRIPTION >

CLIMATE CONTROLLED SEAT

System Diagram

INFOID:0000000010584483

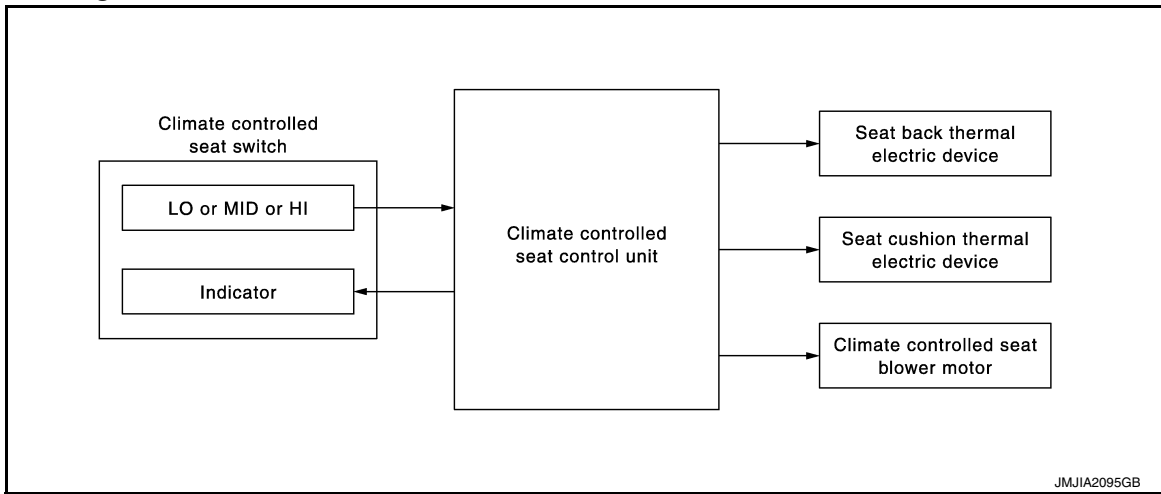

System Description

INFOID:0000000010584484

- The climate controlled seat system is controlled by the climate controlled seat control unit.
- Operation of the climate controlled switch sends heated or cooled airflow and adjusts the seat temperature.

SEAT CUSHION AND SEAT BACK TEMPERATURE ADJUSTMENT FUNCTION

- One thermal electric device (TED) unit is installed in each seat cushion and seatback. The device heats or cools, sends airflow to the seat surface, and adjusts the seat temperature.
- The thermal electric device (TED) is a heat exchanger that has a function to heat or cool the airflow from the climate controlled seat blower motor. (By changing the direction of the current from the power supply, the device takes or gives heat, and adjusts heat exchange process depending on voltage.

NOTE:

The climate controlled seat blower maintains low speed for approximately 60 seconds after turning the climate controlled seat switch.

CAUTION:

- **The thermal electric device has a dual-climate function that allows one side to operate at a high temperature and the other to operate at a low temperature simultaneously.**
- **Before starting the work, always turn OFF the switch and check that the thermal electric device is cold.**

FAIL-SAFE

The fail-safe function is adopted for the climate controlled seat control unit. Refer to [SE-89, "Fail-safe"](#).

CLIMATE CONTROLLED SEAT

< SYSTEM DESCRIPTION >

Component Parts Location

INFOID:000000010584485

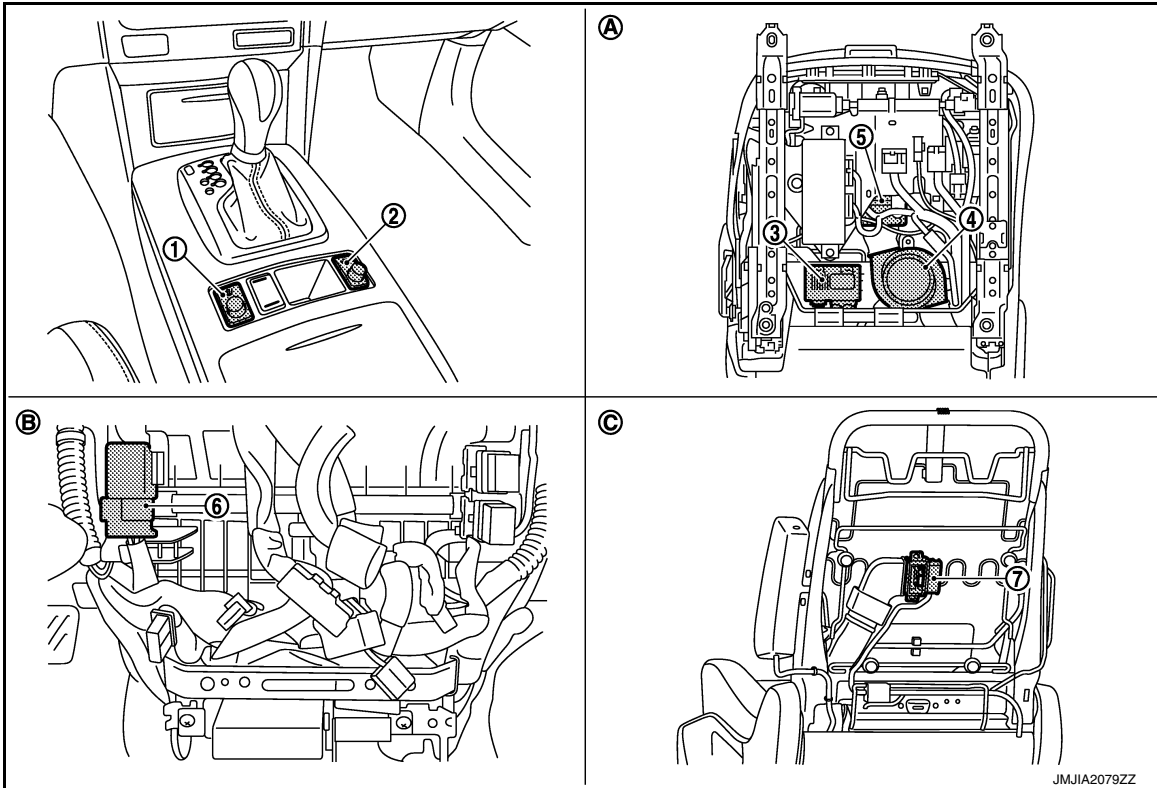

- | | | |
|--|--|--|
| 1. Climate controlled seat switch (driver side) M177 | 2. Climate controlled seat switch (passenger side) M178 | 3. Climate controlled seat control unit (driver side) B507,B508,B509 |
| 4. Climate controlled seat blower motor (driver side) B506 | 5. Seat cushion thermal electric device (driver side) B505 | 6. Climate controlled seat relay M64 |
| 7. Seatback thermal electric device (driver side) B504 | | |

Component Description

INFOID:000000010584486

Item	Function
Climate controlled seat relay	Supplies power to the climate controlled seat control unit in accordance with the key switch position that is ON or OFF
Climate controlled seat control unit	Installed in the seat cushion backside and controls the climate controlled seat blower motor, seatback thermal electric device, and seat cushion thermal electric device in accordance with the input signal
Climate controlled seat switch	Installed in the center console and transmits signals to climate controlled seat control unit in accordance with the HEAT (heated airflow) or COOL (cooled airflow) switch operation and the temperature switch operation
Climate controlled seat blower motor	Installed in the seat cushion backside and sends the airflow to the seatback thermal electric device and seat cushion thermal electric device in accordance with the control from the climate controlled seat control unit
Seatback thermal electric device	Installed in the seatback backside and heats or cools the airflow from the climate controlled seat blower motor in accordance with the control from the climate controlled seat control unit
Seat cushion thermal electric device	Installed in the seat cushion backside and heats or cools the airflow from the climate controlled seat blower motor in accordance with the control from the climate controlled seat control unit

A
B
C
D
E
F
G
H
I

SE

K

L

M

N

O

P

POWER SUPPLY AND GROUND CIRCUIT

< DTC/CIRCUIT DIAGNOSIS >

DTC/CIRCUIT DIAGNOSIS

POWER SUPPLY AND GROUND CIRCUIT HEATED SEAT CONTROL UNIT

HEATED SEAT CONTROL UNIT : Diagnosis Procedure

INFOID:0000000010584487

1. CHECK FUSE

Check that the following fuse is not blown.

Signal name	Fuse No.
Battery power supply	61 (15 A)

Is the inspection result normal?

YES >> GO TO 2.

NO >> Replace the blown fuse after repairing the affected circuit if fuse is blown.

2. CHECK HEATED SEAT CONTROL UNIT POWER SUPPLY 1

1. Turn ignition switch OFF.
2. Disconnect heated seat control unit connector.
3. Turn ignition switch ON.
4. Check voltage between heated seat control unit harness connector and ground.

(+)		Terminal	(-)	Voltage (V) (Approx.)
Heated seat control unit				
Connector				
Driver side	B439	60	Ground	Battery voltage
Passenger side	B462			

Is the inspection result normal?

YES >> GO TO 4.

NO >> GO TO 3.

3. CHECK HEATED SEAT CONTROL UNIT POWER SUPPLY CIRCUIT 1

1. Turn ignition switch OFF.
2. Disconnect heated seat relay.
3. Check continuity between heated seat control unit harness connector and heated seat relay terminal connector.

Heated seat control unit		Terminal	Heated seat relay		Continuity
Connector			Connector	Terminal	
Driver side	B439	60	M174	6	Existed
Passenger side	B462				

4. Check continuity between heated seat control unit harness connector and ground.

Heated seat control unit		Terminal	Ground	Continuity
Connector				
Driver side	B439	60	Ground	Not existed
Passenger side	B462			

Is the inspection result normal?

YES >> Repair or replace harness between heated seat relay and fuse holder.

NO >> Repair or replace harness between heated seat control unit and heated seat relay.

4. CHECK HEATED SEAT CONTROL UNIT POWER SUPPLY 2

Check voltage between heated seat control unit harness connector and ground.

POWER SUPPLY AND GROUND CIRCUIT

< DTC/CIRCUIT DIAGNOSIS >

(+)		Terminal	(-)	Condition	Voltage (V) (Approx.)	
Heated seat control unit						
Connector						
Driver side	B439	66	Ground	Heated seat switch	ON	Battery voltage
					OFF	0
Passenger side	B462			ON	Battery voltage	
				OFF	0	

Is the inspection result normal?

YES >> GO TO 7.

NO >> GO TO 5.

5. CHECK HEATED SEAT CONTROL UNIT POWER SUPPLY CIRCUIT 2

- Turn ignition switch OFF.
- Disconnect heated seat switch connector.
- Check continuity between heated seat control unit harness connector and heated seat switch harness connector.

Heated seat control unit		Terminal	Heated seat switch		Continuity
Connector			Connector	Terminal	
Driver side	B439	66	M172	1	Existed
Passenger side	B462		M173		

- Check continuity between heated seat control unit harness connector and ground.

Heated seat control unit		Terminal	Ground	Continuity
Connector				
Driver side	B439	66		Not existed
Passenger side	B462			

Is the inspection result normal?

YES >> GO TO 6.

NO >> Repair or replace harness.

6. CHECK HEATED SEAT SWITCH

Check heated seat switch.

- Driver side: Refer to [SE-41, "DRIVER SIDE : Component Inspection"](#).
- Passenger side: Refer to [SE-42, "PASSENGER SIDE : Component Inspection"](#).

Is the inspection result normal?

YES >> GO TO 8.

NO >> Replace heated seat switch. Refer to [SE-151, "Removal and Installation"](#).

7. CHECK HEATED SEAT CONTROL UNIT GROUND CIRCUIT

- Turn ignition switch OFF.
- Check continuity between heated seat control unit harness connector and ground.

Heated seat control unit		Terminal	Ground	Continuity
Connector				
Driver side	B439	59		Exists
Passenger side	B462			

Is the inspection result normal?

YES >> INSPECTION END

NO >> Repair or replace harness.

8. CHECK INTERMITTENT INCIDENT

POWER SUPPLY AND GROUND CIRCUIT

< DTC/CIRCUIT DIAGNOSIS >

Check intermittent incident.
Refer to [GI-47, "Intermittent Incident"](#).

>> INSPECTION END

HEATED SEAT SWITCH

HEATED SEAT SWITCH : Diagnosis Procedure

INFOID:000000010584488

1. CHECK FUSE

Check that the following fuse is not blown.

Signal name	Fuse No.
Ignition power supply	3 (10 A)

Is the inspection result normal?

YES >> GO TO 2.

NO >> Replace the blown fuse after repairing the affected circuit if fuse is blown.

2. CHECK HEATED SEAT SWITCH POWER SUPPLY

1. Turn ignition switch OFF.
2. Disconnect heated seat switch connector.
3. Turn ignition switch ON.
4. Check voltage between heated seat switch harness connector and ground.

Heated seat switch		Terminal	(-)	Voltage (V) (Approx.)
Connector				
Driver side	M172	5	Ground	Battery voltage
Passenger side	M173			

Is the inspection result normal?

YES >> INSPECTION END

NO >> GO TO 3.

3. CHECK HEATED SEAT SWITCH POWER SUPPLY CIRCUIT

1. Turn ignition switch OFF.
2. Disconnect fuse block (J/B) connector.
3. Check continuity between heated seat switch harness connector and fuse block (J/B) harness connector.

Heated seat switch		Terminal	Fuse block (J/B)		Continuity
Connector			Connector	Terminal	
Driver side	M172	5	M1	2A	Existed
Passenger side	M173				

4. Check continuity between heated seat switch harness connector and ground.

Heated seat switch		Terminal	Ground	Continuity
Connector				
Driver side	M172	5	Ground	Not existed
Passenger side	M173			

Is the inspection result normal?

YES >> GO TO 4.

NO >> Repair or replace harness.

4. CHECK FUSE BLOCK (J/B)

1. Turn ignition switch ON.

POWER SUPPLY AND GROUND CIRCUIT

< DTC/CIRCUIT DIAGNOSIS >

2. Check voltage between fuse block (J/B) connector (fuse block side) and ground.

(+)		(-)	Voltage (V) (Approx.)
Fuse block (J/B)			
Connector	Terminal	Ground	Battery voltage
M1	2A		

Is the inspection result normal?

YES >> GO TO 5.

NO >> Repair or replace fuse block (J/B).

5.CHECK INTERMITTENT INCIDENT

Check intermittent incident.

Refer to [GI-47, "Intermittent Incident"](#).

>> INSPECTION END

CLIMATE CONTROLLED SEAT CONTROL UNIT

CLIMATE CONTROLLED SEAT CONTROL UNIT : Diagnosis Procedure

INFOID:000000010584489

Driver side

1.CHECK FUSE

Check that the following fuses are not fusing.

Signal name	Fuse No.
Battery power supply	61 (15A)
IGN power supply	3 (10A)

Is the fuse fusing?

YES >> Replace the blown fuse after repairing the affected circuit if a fuse is blown.

NO >> GO TO 2.

2.CHECK CLIMATE CONTROLLED SEAT CONTROL UNIT POWER SUPPLY

1. Turn ignition switch OFF.
2. Disconnect climate controlled seat control unit (driver side) connector.
3. Turn ignition switch ON.
4. Check voltage between climate controlled seat control unit (driver side) harness connector and ground.

(+)		(-)	Voltage (Approx.)
Climate controlled seat control unit (driver side)			
Connector	Terminal	Ground	Battery voltage
B508	55		
B509	70		

Is the measurement value normal?

YES >> GO TO 3.

NO >> GO TO 4.

3.CHECK GROUND CIRCUIT

Check continuity between climate control unit (driver side) harness connector and ground.

Climate controlled seat control unit (driver side)		Ground	Continuity
Connector	Terminal		
B509	56		Existed

Does continuity exist?

POWER SUPPLY AND GROUND CIRCUIT

< DTC/CIRCUIT DIAGNOSIS >

- YES >> INSPECTION END
 NO >> Repair or replace harness or connector.

4. CHECK CLIMATE CONTROLLED SEAT CONTROL UNIT POWER SUPPLY CIRCUIT 1

- Turn ignition switch OFF.
- Disconnect climate controlled seat relay.
- Check continuity between climate controlled seat control unit (driver side) harness connector and climate controlled seat relay harness connector.

Climate controlled seat control unit (driver side)		Climate controlled seat relay		Continuity
Connector	Terminal	Connector	Terminal	
B508	55	M64	6	Existed
B509	70			

- Check continuity between climate controlled seat control unit (driver side) harness connector and ground.

Climate controlled seat control unit (driver side)		Ground	Continuity
Connector	Terminal		
B508	55		Not existed
B509	70		

Is the measurement value normal?

- YES >> GO TO 5.
 NO >> Repair or replace harness or connector.

5. CHECK CLIMATE CONTROLLED SEAT RELAY POWER SUPPLY CIRCUIT 2

- Turn ignition switch ON.
- Check voltage between climate controlled seat relay harness connector and ground.

Terminals		Voltage (Approx.)
(+)	(-)	
Climate controlled seat relay		Ground
Connector	Terminal	
M64	2 7	
		Battery voltage

Is the measurement value normal?

- YES >> GO TO 6.
 NO >> Repair or replace harness or connector.

6. CHECK CLIMATE CONTROLLED SEAT RELAY

Check climate controlled seat relay.

Refer to [SE-20, "CLIMATE CONTROLLED SEAT CONTROL UNIT : Component Inspection"](#)

Is the inspection result normal?

- YES >> GO TO 7.
 NO >> Replace climate controlled seat relay.

7. CHECK CLIMATE CONTROLLED SEAT RELAY GROUND CIRCUIT

Check continuity between climate controlled seat relay harness connector and ground.

Climate controlled seat relay		Ground	Continuity
Connector	Terminal		
M64	1		Existed

Does continuity exist?

- YES >> GO TO 8.
 NO >> Repair or replace harness.

POWER SUPPLY AND GROUND CIRCUIT

< DTC/CIRCUIT DIAGNOSIS >

8. CHECK INTERMITTENT INCIDENT

Refer to [GI-47. "Intermittent Incident"](#).

>> INSPECTION END

Passenger side

1. CHECK FUSE

Check that the following fuses are not fusing.

Signal name	Fuse No.
Battery power supply	62 (15A)
IGN power supply	3 (10A)

Is the fuse fusing?

YES >> Replace the blown fuse after repairing the affected circuit if a fuse is blown.

NO >> GO TO 2.

2. CHECK CLIMATE CONTROLLED SEAT CONTROL UNIT POWER SUPPLY

1. Turn ignition switch OFF.
2. Disconnect climate controlled seat control unit (passenger side) connector.
3. Turn ignition switch ON.
4. Check voltage between climate controlled seat control unit (passenger side) harness connector and ground.

(+)		(-)	Voltage (Approx.)
Connector	Terminal		
B518	55	Ground	Battery voltage
B519	70		

Is the measurement value normal?

YES >> GO TO 3.

NO >> GO TO 4.

3. CHECK GROUND CIRCUIT

Check continuity between harness connector and ground.

Climate controlled seat control unit (passenger side)		Ground	Continuity
Connector	Terminal		
B519	56		Existed

Does continuity exist?

YES >> INSPECTION END

NO >> Repair harness or connector.

4. CHECK CLIMATE CONTROLLED SEAT CONTROL UNIT POWER SUPPLY CIRCUIT 1

1. Turn ignition switch OFF.
2. Disconnect climate controlled seat relay.
3. Check continuity between climate controlled seat control unit (passenger side) harness connector and climate controlled seat relay harness connector.

Climate controlled seat control unit (passenger side)		Climate controlled seat relay		Continuity
Connector	Terminal	Connector	Terminal	
B518	55	M64	3	Existed
B519	70			

POWER SUPPLY AND GROUND CIRCUIT

< DTC/CIRCUIT DIAGNOSIS >

4. Check continuity between climate controlled seat control unit (driver side) harness connector and ground.

Climate controlled seat control unit (driver side)		Ground	Continuity
Connector	Terminal		
B518	55		Not existed
B519	70		

Is the measurement value normal?

YES >> GO TO 5.

NO >> Repair or replace harness or connector.

5. CHECK CLIMATE CONTROLLED SEAT RELAY POWER SUPPLY CIRCUIT 2

1. Turn ignition switch ON.
2. Check voltage between climate controlled seat relay harness connector and ground.

Terminals		Ground	Voltage (Approx.)
(+)	(-)		
Climate controlled seat relay			Battery voltage
Connector	Terminal		
M64	2 5		

Is the measurement value normal?

YES >> GO TO 6.

NO >> Repair or replace harness or connector.

6. CHECK CLIMATE CONTROLLED SEAT RELAY

Check climate controlled seat relay.

Refer to [SE-20, "CLIMATE CONTROLLED SEAT CONTROL UNIT : Component Inspection"](#)

Is the inspection result normal?

YES >> GO TO 7.

NO >> Replace climate controlled seat relay.

7. CHECK CLIMATE CONTROLLED SEAT RELAY GROUND CIRCUIT

Check continuity between climate controlled seat relay harness connector and ground.

Climate controlled seat relay		Ground	Continuity
Connector	Terminal		
M64	1		Existed

Does continuity exist?

YES >> GO TO 8.

NO >> Repair or replace harness.

8. CHECK INTERMITTENT INCIDENT

Refer to [GI-47, "Intermittent Incident"](#).

>> INSPECTION END

CLIMATE CONTROLLED SEAT CONTROL UNIT : Component Inspection INFOID:000000010584490

1. CHECK CLIMATE CONTROLLED SEAT RELAY

1. Turn ignition switch OFF.
2. Disconnect climate controlled seat relay.

POWER SUPPLY AND GROUND CIRCUIT

< DTC/CIRCUIT DIAGNOSIS >

3. Check climate controlled seat relay.

Climate controlled seat relay		Condition	Continuity
Terminal			
3	5	12 V direct current supply between terminals 1 and 2.	Existed
		No current supply	Not existed
6	7	12 V direct current supply between terminals 1 and 2.	Existed
		No current supply	Not existed

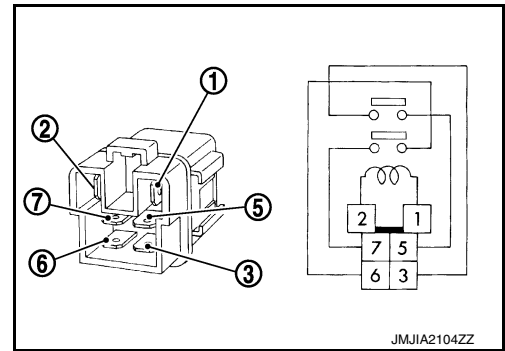

Is the inspection result normal?

YES >> INSPECTION END.

NO >> Replace climate controlled seat relay.

A
B
C
D
E
F
G
H
I
K
L
M
N
O
P

SE

CLIMATE CONTROLLED SEAT SWITCH

< DTC/CIRCUIT DIAGNOSIS >

CLIMATE CONTROLLED SEAT SWITCH

Description

INFOID:000000010584491

Installed in the center console and transmits signals to climate controlled seat control unit in accordance with the HEAT or COOL switch operation and the temperature switch operation.

Component Function Check

INFOID:000000010584492

1.CHECK FUNCTION

Check that climate controlled seat activates when operating climate controlled seat control switch.

Is the inspection result normal?

- YES >> Climate controlled seat switch is OK.
 NO >> Refer to [SE-22, "Diagnosis Procedure"](#).

Diagnosis Procedure

INFOID:000000010584493

1.CHECK CLIMATE CONTROLLED SEAT CONTROL UNIT INPUT SIGNAL

- Turn ignition switch ON.
- Check voltage between climate controlled seat control unit harness connector and ground.

(+)		(-)	Condition	Voltage (V) (Approx.)	
Climate controlled seat control unit					
Connector	Terminal				
Driver side	B508	6	Climate controlled seat switch	LO COOL	0.8 - 1.5
				MID COOL	1.6 - 2.5
				HI COOL	2.6 - 4.2
				OFF	0
		16	Climate controlled seat switch	LO HEAT	0.8 - 1.5
				MID HEAT	1.6 - 2.5
				HI HEAT	2.6 - 4.2
				OFF	0
Passenger side	B518	6	Climate controlled seat switch	LO COOL	0.8 - 1.5
				MID COOL	1.6 - 2.5
				HI COOL	2.6 - 4.2
				OFF	0
		16	Climate controlled seat switch	LO HEAT	0.8 - 1.5
				MID HEAT	1.6 - 2.5
				HI HEAT	2.6 - 4.2
				OFF	0

Is the inspection result normal?

- YES >> Climate controlled seat switch circuit is OK.
 NO-1 >> HEAT or COOL mode is NG:GO TO 2.
 NO-2 >> HEAT and COOL modes are NG: GO TO 3.

2.CHECK CLIMATE CONTROLLED SEAT SWITCH CIRCUIT

- Turn ignition switch OFF.
- Disconnect climate controlled seat switch connector and climate controlled seat control unit connector.
- Check continuity between climate controlled seat switch harness connector and climate controlled seat control unit harness connector.

CLIMATE CONTROLLED SEAT SWITCH

< DTC/CIRCUIT DIAGNOSIS >

Climate controlled seat switch			Climate controlled seat control unit		Continuity
Connector		Terminal	Connector	Terminal	
Driver side	COOL	M177	B508	2	Existed
	HEAT			3	
Passenger side	COOL	M178	B518	2	
	HEAT			3	
				6	
				16	
				6	
				16	

4. Check continuity between climate controlled seat switch harness connector and ground.

Climate controlled seat switch			Ground	Continuity	
Connector		Terminal			
Driver side	COOL	M177	Ground	Not existed	
	HEAT				2
Passenger side	COOL	M178			3
	HEAT				2
			3		

Is the inspection result normal?

YES >> GO TO 5.

NO >> Repair or replace harness.

3. CHECK CLIMATE CONTROLLED SEAT SWITCH POWER SUPPLY

1. Turn ignition switch OFF.
2. Disconnect climate controlled seat switch connector.
3. Turn ignition switch ON.
4. Check voltage between climate controlled seat switch harness connector and ground.

Climate controlled seat switch			Ground	Voltage (V) (Approx.)
Connector		Terminal		
Driver side	M177	1	Ground	Battery voltage
Passenger side	M178	1		

Is the inspection result normal?

YES >> GO TO 5.

NO >> GO TO 4.

4. CHECK CLIMATE CONTROLLED SEAT SWITCH POWER SUPPLY CIRCUIT

1. Turn ignition switch OFF.
2. Disconnect climate controlled seat control unit connector.
3. Check continuity between climate controlled seat switch harness connector and climate controlled seat control unit harness connector.

Climate controlled seat switch			Climate controlled seat control unit		Continuity
Connector		Terminal	Connector	Terminal	
Driver side	M177	1	B508	21	Existed
Passenger side	M178	1	B518	21	

4. Check continuity between climate controlled seat switch harness connector and ground.

Climate controlled seat switch			Ground	Continuity
Connector		Terminal		
Driver side	M177	1	Ground	Not existed
Passenger side	M178	1		

Is the inspection result normal?

CLIMATE CONTROLLED SEAT SWITCH

< DTC/CIRCUIT DIAGNOSIS >

- YES >> Replace climate controlled seat control unit. Refer to [SE-126. "Disassembly and Assembly"](#).
NO >> Repair or replace harness.

5.CHECK CLIMATE CONTROLLED SEAT SWITCH

Check climate controlled seat switch.

Refer to [SE-24. "Component Inspection"](#).

Is the inspection result normal?

- YES >> GO TO 6.
NO >> Replace Climate controlled seat switch. Refer to [SE-148. "Removal and Installation"](#).

6.CHECK INTERMITTENT INCIDENT

Refer to [GI-47. "Intermittent Incident"](#).

>> INSPECTION END

Component Inspection

INFOID:0000000010584494

1.CHECK CLIMATE CONTROLLED SEAT SWITCH

1. Turn ignition OFF.
2. Disconnect climate controlled seat switch connector.
3. Check climate controlled seat switch terminals.

Climate controlled seat switch		Terminal		Condition		Continuity	
Driver side	M177	2	1	Climate controlled seat switch	COOL mode	Pressed	Existed
					Released	Not existed	
		3		HEAT mode	Pressed	Existed	
				Released	Not existed		
Passenger side	M178	2	1	Climate controlled seat switch	COOL mode	Pressed	Existed
					Released	Not existed	
		3		HEAT mode	Pressed	Existed	
				Released	Not existed		

Is the inspection result normal?

- YES >> Climate controlled seat switch is OK.
NO >> Replace climate controlled seat switch. Refer to [SE-148. "Removal and Installation"](#).

SEATBACK THERMAL ELECTRIC DEVICE

< DTC/CIRCUIT DIAGNOSIS >

SEATBACK THERMAL ELECTRIC DEVICE

Description

INFOID:000000010584495

Installed in the seatback backside and heats or cools the airflow from the climate controlled seat blower motor in accordance with the control from the climate controlled seat control unit.

Component Function Check

INFOID:000000010584496

1.CHECK FUNCTION

Checks whether or not the temperature of the seatback thermal electric device changes in accordance with the HEAT or COOL switch operation of the climate controlled seat control switch.

Is the inspection result normal?

YES >> Seatback thermal electric device function is OK.

NO >> Refer to [SE-25. "Diagnosis Procedure"](#).

Diagnosis Procedure

INFOID:000000010584497

1.CHECK SEATBACK THERMAL ELECTRIC DEVICE SIGNAL

1. Turn ignition switch ON.
2. Check voltage between seatback thermal electric device harness connector and ground.

(+)		Terminal	(-)	Condition	Voltage (V) (Approx.)
Seatback thermal electric device					
Connector					
Driver side	B504	35	Ground	Climate controlled seat switch	HEAT and COOL 0 - battery voltage*
		36		Other than above	0
Passenger side	B514			35	Climate controlled seat switch
		36		Other than above	0

*:It changes between battery voltage or 0V

NOTE:

Wait 1 minute or more after the activation start, and then start the measurement.

Is the inspection result normal?

YES >> Replace seatback thermal electric device.

NO >> GO TO 2.

2.CHECK SEATBACK THERMAL ELECTRIC DEVICE CIRCUIT

1. Turn ignition switch OFF.
2. Disconnect climate controlled seat control unit connector and seatback thermal electric device connector.
3. Check continuity between climate controlled seat control unit harness connector and seatback thermal electric device harness connector.

Climate controlled seat control unit		Seatback thermal electric device		Continuity
Connector	Terminal	Connector	Terminal	
Driver side	B509	B504	35	Existed
			36	
Passenger side	B519	B514	35	
			36	

4. Check continuity between climate controlled seat control unit harness connector and ground.

SEATBACK THERMAL ELECTRIC DEVICE

< DTC/CIRCUIT DIAGNOSIS >

Climate controlled seat control unit			Ground	Continuity
Connector		Terminal		Not existed
Driver side	B509	35		
		36		
Passenger side	B519	35		
		36		

Is the inspection result normal?

- YES >> Replace climate controlled seat control unit. Refer to [SE-126, "Disassembly and Assembly"](#).
NO >> Repair or replace harness.

SEATBACK THERMAL ELECTRIC DEVICE SENSOR

< DTC/CIRCUIT DIAGNOSIS >

SEATBACK THERMAL ELECTRIC DEVICE SENSOR

Description

INFOID:000000010584498

Measures seatback temperature.

Diagnosis Procedure

INFOID:000000010584499

1. CHECK SEATBACK THERMAL ELECTRIC DEVICE SENSOR CIRCUIT

1. Turn ignition switch ON.
2. Check voltage between climate controlled seat control unit harness connector and ground.

(+)		Terminal	(-)	Condition	Voltage (V) (Approx.)
Climate controlled seat control unit					
Connector					
Driver side	B507	37	Ground	Climate controlled seat operated	1 - 5
Passenger side	B517				

Is the inspection result normal?

YES >> Seatback thermal electric device sensor circuit is OK.

NO >> GO TO 2.

2. CHECK SEATBACK THERMAL ELECTRIC DEVICE SENSOR HARNESS

1. Turn ignition switch OFF.
2. Disconnect climate controlled seat control unit connector and seatback thermal electric device connector.
3. Check continuity between climate controlled seat control unit harness connector and seatback thermal electric device harness connector.

Climate controlled seat control unit		Seatback thermal electric device		Continuity
Connector	Terminal	Connector	Terminal	
Driver side	B507	B504	37	Existed
			38	
Passenger side	B517	B514	37	
			38	

4. Check continuity between font ventilation seat control unit harness connector and ground.

Climate controlled seat control unit		Terminal	Ground	Continuity
Connector				
Driver side	B507	37	Ground	Not existed
		38		
Passenger side	B517	37		
		38		

Is the inspection result normal?

YES >> GO TO 3.

NO >> Repair or replace harness.

3. CHECK SEATBACK THERMAL ELECTRIC DEVICE SENSOR

Check resistance between seatback thermal electric device connector.

Seatback thermal electric device		Terminal		Resistance (KΩ) (Approx.)
Connector				
Driver side	B504	37	38	1
Passenger side	B514			

SEATBACK THERMAL ELECTRIC DEVICE SENSOR

< DTC/CIRCUIT DIAGNOSIS >

Is the inspection result normal?

- YES >> Replace climate controlled seat control unit. Refer to [SE-125, "Removal and Installation"](#).
- NO >> Replace seatback thermal electric device.

SEAT CUSHION THERMAL ELECTRIC DEVICE

< DTC/CIRCUIT DIAGNOSIS >

SEAT CUSHION THERMAL ELECTRIC DEVICE

Description

INFOID:0000000110584500

Installed in the seat cushion backside and heats or cools the airflow from the climate controlled seat blower motor in accordance with the control from the climate controlled seat control unit.

Component Function Check

INFOID:0000000110584501

1.CHECK FUNCTION

Checks whether or not the temperature of the seat cushion thermal electric device changes in accordance with the HEAT or COOL switch operation of the climate controlled seat control switch.

Is the inspection result normal?

YES >> Seat cushion thermal electric device function is OK.

NO >> Refer to [SE-25. "Diagnosis Procedure"](#).

Diagnosis Procedure

INFOID:0000000110584502

1.CHECK SEAT CUSHION THERMAL ELECTRIC DEVICE SIGNAL

1. Turn ignition switch ON.
2. Check voltage between seat cushion thermal electric device harness connector and ground.

(+)		Terminal	(-)	Condition	Voltage (V) (Approx.)
Seat cushion thermal electric device					
Connector					
Driver side	B505	31	Ground	HEAT and COOL	0 - battery voltage*
				Other than above	0
		32		HEAT and COOL	0 - battery voltage*
				Other than above	0
Passenger side	B515	31		HEAT and COOL	0 - battery voltage*
				Other than above	0
		32		HEAT and COOL	0 - battery voltage*
				Other than above	0

*:It changes between battery voltage or 0V

NOTE:

Wait 1 minute or more after the activation start, and then start the measurement.

Is the inspection result normal?

YES >> Replace seat cushion thermal electric device.

NO >> GO TO 2.

2.CHECK SEAT CUSHION THERMAL ELECTRIC DEVICE CIRCUIT

1. Turn ignition switch OFF.
2. Disconnect climate controlled seat control unit connector and seat cushion thermal electric device connector.
3. Check continuity between climate controlled seat control unit harness connector and seat cushion thermal electric device harness connector.

Climate controlled seat control unit		Seat cushion thermal electric device		Continuity
Connector	Terminal	Connector	Terminal	
Driver side	B509	B505	31	Existed
			32	
Passenger side	B519		31	
			32	

SEAT CUSHION THERMAL ELECTRIC DEVICE

< DTC/CIRCUIT DIAGNOSIS >

4. Check continuity between climate controlled seat control unit harness connector and ground.

Climate controlled seat control unit			Ground	Continuity
Connector		Terminal		
Driver side	B509	31		Not existed
		32		
Passenger side	B519	31		
		32		

Is the inspection result normal?

- YES >> Replace climate controlled seat control unit. Refer to [SE-126, "Disassembly and Assembly"](#).
NO >> Repair or replace harness.

SEAT CUSHION THERMAL ELECTRIC DEVICE SENSOR

< DTC/CIRCUIT DIAGNOSIS >

SEAT CUSHION THERMAL ELECTRIC DEVICE SENSOR

Description

INFOID:000000010584503

Measures seat cushion temperature.

Diagnosis Procedure

INFOID:000000010584504

1. CHECK SEAT CUSHION THERMAL ELECTRIC DEVICE SENSOR CIRCUIT

1. Turn ignition switch ON.
2. Check voltage between climate controlled seat control unit harness connector and ground.

(+)		Terminal	(-)	Condition	Voltage (V) (Approx.)
Climate controlled seat control unit					
Connector					
Driver side	B507	34	Ground	Climate controlled seat operated	1 - 5
Passenger side	B517				

Is the inspection result normal?

YES >> Seat cushion thermal electric device sensor circuit is OK.

NO >> GO TO 2.

2. CHECK SEAT CUSHION THERMAL ELECTRIC DEVICE SENSOR HARNESS

1. Turn ignition switch OFF.
2. Disconnect climate controlled seat control unit connector and seat cushion thermal electric device connector.
3. Check continuity between climate controlled seat control unit harness connector and seat cushion thermal electric device harness connector.

Climate controlled seat control unit		Seat cushion thermal electric device		Continuity
Connector	Terminal	Connector	Terminal	
Driver side	B507	B505	33	Existed
			34	
Passenger side	B517	B515	33	
			34	

4. Check continuity between font ventilation seat control unit harness connector and ground.

Climate controlled seat control unit		Terminal	Ground	Continuity
Connector				
Driver side	B507	33	Ground	Not existed
		34		
Passenger side	B517	33		
		34		

Is the inspection result normal?

YES >> GO TO 3.

NO >> Repair or replace harness.

3. CHECK SEAT CUSHION THERMAL ELECTRIC DEVICE SENSOR

Check resistance between seat cushion thermal electric device connector.

SEAT CUSHION THERMAL ELECTRIC DEVICE SENSOR

< DTC/CIRCUIT DIAGNOSIS >

Seat cushion thermal electric device		Terminal		Resistance (K Ω) (Approx.)
Connector				
Driver side	B505	33	34	1
Passenger side	B515			

Is the inspection result normal?

- YES >> Replace climate controlled seat control unit. Refer to [SE-125, "Removal and Installation"](#).
NO >> Replace seat cushion thermal electric device.

CLIMATE CONTROLLED SEAT BLOWER MOTOR

< DTC/CIRCUIT DIAGNOSIS >

CLIMATE CONTROLLED SEAT BLOWER MOTOR

Description

INFOID:000000010584505

Sends air flow to the seat cushion and seatback.

Component Function Check

INFOID:000000010584506

1.CHECK FUNCTION

When turning the climate controlled seat switch to the HEAT and COOL mode position, check that the climate controlled seat blower is operated in each specific mode.

Is the inspection result normal?

- YES >> Climate controlled seat blower motor is OK.
- NO >> Refer to [SE-33. "Diagnosis Procedure"](#).

Diagnosis Procedure

INFOID:000000010584507

1.CHECK CLIMATE CONTROLLED SEAT BLOWER MOTOR POWER SUPPLY

1. Turn ignition switch ON.
2. Check voltage between climate controlled seat blower motor harness connector and ground.

(+)		Terminal	(-)	Condition	Voltage (V) (Approx.)	
Climate controlled seat blower motor						
Connector						
Driver side	B506	39	Ground	Climate controlled seat switch	HEAT mode	Battery voltage
					COOL mode	
					Other than above	
Passenger side	B516			Climate controlled seat switch	HEAT mode	Battery voltage
					COOL mode	
					Other than above	

Is the inspection result normal?

- YES >> GO TO 3.
- NO >> GO TO 2.

2.CHECK CLIMATE CONTROLLED BLOWER MOTOR POWER SUPPLY CIRCUIT

1. Turn ignition switch OFF.
2. Disconnect climate controlled blower motor connector and climate controlled seat control unit connector.
3. Check continuity between climate controlled seat blower motor harness connector and climate controlled seat control unit harness connector.

Climate controlled seat blower motor		Climate controlled seat control unit		Continuity
Connector	Terminal	Connector	Terminal	
Driver side	B506	B507	39	Existed
Passenger side	B516			

4. Check continuity between climate controlled seat blower motor harness connector and ground.

Climate controlled seat blower motor		Terminal	Ground	Continuity
Connector				
Driver side	B506	39		Not existed
Passenger side	B516			

Is the inspection result normal?

- YES >> Replace climate controlled seat control unit. Refer to [SE-126. "Disassembly and Assembly"](#).
- NO >> Repair or replace harness.

CLIMATE CONTROLLED SEAT BLOWER MOTOR

< DTC/CIRCUIT DIAGNOSIS >

3. CHECK CLIMATE CONTROLLED SEAT BLOWER MOTOR SPEED CONTROL SIGNAL

Check voltage between climate controlled seat blower motor harness connector and ground.

(+)		Terminal	(-)	Condition	Voltage (V) (Approx.)	
Climate controlled seat blower motor						
Connector						
Driver side	B506	40	Ground	Climate controlled seat	HEAT mode	8.5 - 9
					LO COOL	8
MID COOL	9					
Passenger side	B516				HI COOL	12
					Other than above	0

Is the inspection result normal?

YES >> GO TO 5.

NO >> GO TO 4.

4. CHECK CLIMATE CONTROLLED SEAT BLOWER MOTOR SPEED CONTROL SIGNAL CIRCUIT

1. Turn ignition switch OFF.
2. Disconnect climate controlled seat blower motor connector and climate controlled seat control unit connector.
3. Check continuity between climate controlled seat blower motor harness connector and climate controlled seat control unit harness connector.

Climate controlled seat blower motor		Climate controlled seat control unit		Continuity
Connector	Terminal	Connector	Terminal	
Driver side	B506	B507	40	Existed
Passenger side	B516			

4. Check continuity between climate controlled seat blower motor harness connector and ground.

Climate controlled seat blower motor		Ground	Continuity
Connector	Terminal		
Driver side	B506	40	Not existed
Passenger side	B516		

Is the inspection result normal?

YES >> Replace climate controlled seat control unit. Refer to [SE-126, "Disassembly and Assembly"](#).

NO >> Repair or replace harness.

5. CHECK CLIMATE CONTROLLED SEAT BLOWER MOTOR GROUND CIRCUIT

1. Turn ignition switch OFF.
2. Disconnect climate controlled seat blower motor and climate controlled seat control unit connector.
3. Check continuity between climate controlled seat blower motor harness connector and climate controlled seat control unit harness connector.

Climate controlled seat blower motor		Climate controlled seat control unit		Continuity
Connector	Terminal	Connector	Terminal	
Driver side	B506	B507	41	Existed
Passenger side	B516			

4. Check continuity between climate controlled seat blower motor harness connector and ground.

CLIMATE CONTROLLED SEAT BLOWER MOTOR

< DTC/CIRCUIT DIAGNOSIS >

Climate controlled seat blower motor		Terminal	Ground	Continuity
Connector				Continuity
Driver side	B506	41		Not existed
Passenger side	B516			Not existed

Is the inspection result normal?

YES >> GO TO 6.

NO >> Repair or replace harness.

6. CHECK CLIMATE CONTROLLED SEAT BLOWER MOTOR GROUND

1. Connect climate controlled seat blower motor connector and climate controlled seat control unit connector.
2. Check continuity between climate controlled seat blower motor harness connector and ground.

Climate controlled seat blower motor		Terminal	Ground	Continuity
Connector				Continuity
Driver side	B506	41		Existed
Passenger side	B516			Existed

Is the inspection result normal?

YES >> Replace climate controlled seat control unit. Refer to [SE-126, "Disassembly and Assembly"](#).

NO >> Replace climate controlled seat blower motor. Refer to [SE-126, "Disassembly and Assembly"](#).

A
B
C
D
E
F
G
H
I
K
L
M
N
O
P

SE

CLIMATE CONTROLLED SEAT SWITCH INDICATOR

< DTC/CIRCUIT DIAGNOSIS >

CLIMATE CONTROLLED SEAT SWITCH INDICATOR

Description

INFOID:000000010584508

Turns ON the indicator that indicates the operating status of climate controlled seat HEAT or COOL mode.

Component Function Check

INFOID:000000010584509

1.CHECK FUNCTION

Check that the related indicator lamp illuminates when climate controlled seat switch is set to HEAT or COOL mode.

Is the inspection result normal?

- YES >> Climate controlled seat switch indicator function is OK.
- NO >> Refer to [SE-36. "Diagnosis Procedure"](#).

Diagnosis Procedure

INFOID:000000010584510

1.CHECK CLIMATE CONTROLLED SEAT SWITCH INDICATOR

Check climate controlled seat switch indicator.

Which side of indicator does not turn ON?

- Only HEAT or COOL mode>>GO TO 3.
- Both HEAT and COOL mode>>GO TO 2.

2.CHECK CLIMATECONTROLLED SEAT SWITCH GROUND CIRCUIT

1. Turn ignition switch OFF.
2. Disconnect climate controlled seat switch connector.
3. Check continuity between climate controlled seat switch harness connector and ground.

Climate controlled seat switch		Ground	Continuity
Connector	Terminal		
Driver side	M177	6	Existed
Passenger side	M178		

Is the inspection result normal?

- YES >> GO TO 5.
- NO >> Repair or replace harness.

3.CHECK CLIMATE CONTROLLED SEAT CONTROL UNIT OUTPUT SIGNAL

1. Turn ignition switch ON.
2. Check voltage between climate controlled seat control unit harness connector and ground.

Climate controlled seat control unit		Terminal	(-)	Condition	Voltage (V) (Approx.)
Connector					
Driver side	B507	7	Ground	HEAT mode	Battery voltage
		15		OFF	0
Passenger side	B517			7	COOL mode
		15			OFF
Passenger side	B517		7	HEAT mode	Battery voltage
		15		OFF	0
Passenger side	B517		15	COOL mode	Battery voltage
		OFF		0	

Is the inspection result normal?

- YES >> GO TO 4.

CLIMATE CONTROLLED SEAT SWITCH INDICATOR

< DTC/CIRCUIT DIAGNOSIS >

NO >> Replace climate controlled seat control unit. Refer to [SE-126. "Disassembly and Assembly"](#).

4. CHECK CLIMATE CONTROLLED SEAT SWITCH INDICATOR CIRCUIT

1. Turn ignition switch OFF.
2. Disconnect climate controlled seat control unit connector and climate controlled seat switch.
3. Check continuity between climate controlled seat switch harness connector and climate controlled seat control unit harness connector.

Climate controlled seat switch		Climate controlled seat control unit		Continuity
Connector	Terminal	Connector	Terminal	
Driver side	M177	B507	4	15
			5	7
Passenger side	M178	B517	4	15
			5	7

4. Check continuity between climate controlled seat switch harness connector and ground.

Climate controlled seat switch		Ground	Continuity
Connector	Terminal		
Driver side	M177	4	Not existed
		5	
Passenger side	M178	4	
		5	

Is the inspection result normal?

YES >> GO TO 5.

NO >> Repair or replace harness.

5. CHECK CLIMATE CONTROLLED SEAT SWITCH INDICATOR

Check climate controlled seat switch.

Refer to [SE-37. "Component Inspection"](#).

Is the inspection result normal?

YES >> GO TO 6.

NO >> Replace climate controlled seat switch. Refer to [SE-148. "Removal and Installation"](#)

6. CHECK INTERMITTENT INCIDENT

Refer to [GI-47. "Intermittent Incident"](#).

>> INSPECTION END

Component Inspection

INFOID:000000010584511

1. CHECK CLIMATE CONTROLLED SEAT SWITCH INDICATOR

1. Turn ignition OFF.
2. Disconnect climate controlled seat switch connector.
3. Check climate controlled seat switch terminals.

Climate controlled seat switch		Terminal		Continuity
		(+)*	(-)*	
Driver side	COOL indicator	4	6	Existed
	HEAT indicator	5		
Passenger side	COOL indicator	4	6	
	HEAT indicator	5		

*For a digital tester.

NOTE:

CLIMATE CONTROLLED SEAT SWITCH INDICATOR

< DTC/CIRCUIT DIAGNOSIS >

When checking by an analog tester, the polarity (+) and (-) becomes inverse.

Is the inspection result normal?

YES >> Climate controlled seat switch indicator is OK.

NO >> Replace climate controlled seat switch. Refer to [SE-148, "Removal and Installation"](#).

CLIMATE CONTROLLED SEAT BLOWER FILTER

< DTC/CIRCUIT DIAGNOSIS >

CLIMATE CONTROLLED SEAT BLOWER FILTER

Diagnosis Procedure

INFOID:000000010584512

1. CHECK CLIMATE CONTROLLED SEAT BLOWER FILTER

Remove climate controlled seat blower motor filter and check that there is no clogging by dirt or foreign matters.

Is the inspection result normal?

YES >> INSPECTION END

NO >> Replace climate controlled seat blower filter. Refer to [SE-149. "Removal and Installation"](#).

A
B
C
D
E
F
G
H
I
K
L
M
N
O
P

SE

HEATED SEAT SWITCH

< DTC/CIRCUIT DIAGNOSIS >

HEATED SEAT SWITCH DRIVER SIDE

DRIVER SIDE : Description

INFOID:000000010584513

Adjusts heated seat temperature and deactivates heated seat.

DRIVER SIDE : Component Function Check

INFOID:000000010584514

1. CHECK HEATED SEAT SWITCH FUNCTION

Check that heated seat warms to preset temperature when operating heated seat switch to the optimal position.

Is the inspection result normal?

YES >> Heated seat switch function is OK.

NO >> Refer to [SE-40, "DRIVER SIDE : Diagnosis Procedure"](#).

DRIVER SIDE : Diagnosis Procedure

INFOID:000000010584515

1. CHECK HEATED SEAT CONTROL UNIT INPUT SIGNAL

1. Turn ignition switch ON.
2. Check voltage between heated seat control unit harness connector and ground.

(+)		(-)	Condition	Voltage (V) (Approx.)	
Heated seat control unit					
Connector	Terminal				
B439	67	Ground	Heated seat switch position	OFF	0
				1 (Min. temperature)	12.24
				2	12.33
				3	12.49
				4	12.63
				5	12.76
				6 (Max. temperature)	12.90

Is the inspection result normal?

YES >> Heated seat switch circuit is OK.

NO >> GO TO 2.

2. CHECK HEATED SEAT SWITCH CIRCUIT

1. Turn ignition switch OFF.
2. Disconnect heated seat switch connector.
3. Check continuity between heated seat switch harness connector and heated seat control unit harness connector.

Heated seat switch		Heated seat control unit		Continuity
Connector	Terminal	Connector	Terminal	
M172	2	B439	67	Existed

4. Check continuity between heated seat switch harness connector and ground.

Heated seat switch		Ground	Continuity
Connector	Terminal		
M172	2		Not existed

Is the inspection result normal?

YES >> GO TO 3.

NO >> Repair or replace harness.

HEATED SEAT SWITCH

< DTC/CIRCUIT DIAGNOSIS >

3. CHECK HEATED SEAT SWITCH

Check heated seat switch.

Refer to [SE-41, "DRIVER SIDE : Component Inspection"](#).

Is the inspection result normal?

YES >> GO TO 4.

NO >> Replace heated seat switch. Refer to [SE-151, "Removal and Installation"](#).

4. CHECK INTERMITTENT INCIDENT

Check intermittent incident.

Refer to [GI-47, "Intermittent Incident"](#).

>> INSPECTION END

DRIVER SIDE : Component Inspection

INFOID:0000000010584516

1. CHECK FRONT HEATED SEAT SWITCH

1. Turn ignition OFF.
2. Disconnect heated seat switch connector.
3. Check resistance between heated seat switch terminals as follows.

Heated seat switch		Condition	Resistance (K Ω) (Approx.)
Terminal			
5	1	ON	0
	2	OFF	∞
		1 (Min. temperature)	2.400
		2	1.800
		3	1.200
		4	0.910
		5	0.620
6 (Max. temperature)	0.348		

Is the inspection result normal?

YES >> INSPECTION END

NO >> Replace heated seat switch. Refer to [SE-151, "Removal and Installation"](#).

PASSENGER SIDE

PASSENGER SIDE : Description

INFOID:0000000010584517

Adjusts heated seat temperature and deactivates heated seat.

PASSENGER SIDE : Component Function Check

INFOID:0000000010584518

1. CHECK HEATED SEAT SWITCH FUNCTION

Check that heated seat warms to preset temperature when operating heated seat switch to the optimal position.

Is the inspection result normal?

YES >> Heated seat switch function is OK.

NO >> Refer to [SE-41, "PASSENGER SIDE : Diagnosis Procedure"](#).

PASSENGER SIDE : Diagnosis Procedure

INFOID:0000000010584519

1. CHECK HEATED SEAT CONTROL UNIT INPUT SIGNAL

1. Turn ignition switch ON.
2. Check voltage between heated seat control unit harness connector and ground.

HEATED SEAT SWITCH

< DTC/CIRCUIT DIAGNOSIS >

(+)		(-)	Condition	Voltage (V) (Approx.)	
Heated seat control unit					
Connector	Terminal				
B462	67	Ground	Heated seat switch position	OFF	0
				1 (Min. temperature)	12.24
				2	12.33
				3	12.49
				4	12.63
				5	12.76
				6 (Max. temperature)	12.90

Is the inspection result normal?

YES >> Heated seat switch circuit is OK.

NO >> GO TO 2.

2. CHECK HEATED SEAT SWITCH CIRCUIT

1. Turn ignition switch OFF.
2. Disconnect heated seat switch connector.
3. Check continuity between heated seat switch harness connector and heated seat control unit harness connector.

Heated seat switch		Heated seat control unit		Continuity
Connector	Terminal	Connector	Terminal	
M173	2	B462	67	Existed

4. Check continuity between heated seat switch harness connector and ground.

Heated seat switch		Ground	Continuity
Connector	Terminal		Not existed
M173	2		

Is the inspection result normal?

YES >> GO TO 3.

NO >> Repair or replace harness.

3. CHECK HEATED SEAT SWITCH

Check heated seat switch.

Refer to [SE-42, "PASSENGER SIDE : Component Inspection"](#).

Is the inspection result normal?

YES >> GO TO 4.

NO >> Replace heated seat switch. Refer to [SE-151, "Removal and Installation"](#).

4. CHECK INTERMITTENT INCIDENT

Check intermittent incident.

Refer to [GI-47, "Intermittent Incident"](#).

>> INSPECTION END

PASSENGER SIDE : Component Inspection

INFOID:0000000010584520

1. CHECK FRONT HEATED SEAT SWITCH

1. Turn ignition OFF.
2. Disconnect heated seat switch connector.
3. Check resistance between heated seat switch terminals as follows.

HEATED SEAT SWITCH

< DTC/CIRCUIT DIAGNOSIS >

Heated seat switch		Condition		Resistance (KΩ) (Approx.)
Terminal				
5	1	Heated seat switch position	ON	0
	2		OFF	∞
			1 (Min. temperature)	2.400
			2	1.800
			3	1.200
			4	0.910
			5	0.620
	6 (Max. temperature)		0.348	

Is the inspection result normal?

YES >> INSPECTION END

NO >> Replace heated seat switch. Refer to [SE-151, "Removal and Installation"](#).

A
B
C
D
E
F
G
H
I
K
L
M
N
O
P

SE

HEATED SEAT RELAY

< DTC/CIRCUIT DIAGNOSIS >

HEATED SEAT RELAY

Description

INFOID:0000000010584521

Power is supplied to the heated seat using ignition power supply control.

Component Function Check

INFOID:0000000010584522

1. CHECK HEATED SEAT RELAY FUNCTION

Check that heated seat warms to preset temperature when operating heated seat switch to the optimal position.

Is the inspection result normal?

- YES >> Heated seat relay function is OK.
NO >> Refer to [SE-44, "Diagnosis Procedure"](#)

Diagnosis Procedure

INFOID:0000000010584523

1. CHECK HEATED SEAT RELAY POWER SUPPLY

1. Turn ignition switch OFF.
2. Disconnect heated seat relay.
3. Turn ignition switch ON.
4. Check voltage between heated seat relay terminal connector and ground.

(+)		(-)	Voltage (V) (Approx.)
Heated seat relay			
Connector	Terminal	Ground	Battery voltage
M174	2		

Is the inspection result normal?

- YES >> GO TO 3.
NO >> GO TO 2.

2. CHECK HEATED SEAT RELAY POWER SUPPLY CIRCUIT

1. Turn ignition switch OFF.
2. Disconnect fuse block (J/B) connector.
3. Check continuity between heated seat relay terminal connector and fuse block (J/B) harness connector.

Heated seat relay		Fuse block (J/B)		Continuity
Connector	Terminal	Connector	Terminal	
M174	2	M1	2A	Existed

4. Check continuity between heated seat relay terminal connector and ground.

Heated seat relay		Ground	Continuity
Connector	Terminal		
M174	2		Not existed

Is the inspection result normal?

- YES >> GO TO 5.
NO >> Repair or replace harness.

3. CHECK HEATED SEAT RELAY GROUND CIRCUIT

1. Turn ignition switch OFF.
2. Check continuity between heated seat relay terminal connector and ground.

HEATED SEAT RELAY

< DTC/CIRCUIT DIAGNOSIS >

Heated seat relay		Ground	Continuity
Connector	Terminal		Existed
M174	1		

Is the inspection result normal?

- YES >> GO TO 4.
 NO >> Repair or replace harness.

4.CHECK HEATED SEAT RELAY

Check heated seat relay.

Refer to [SE-45, "Component Inspection"](#).

Is the inspection result normal?

- YES >> Heated seat relay is OK.
 NO >> Replace heated seat relay.

5.CHECK INTERMITTENT INCIDENT

Check intermittent incident.

Refer to [GI-47, "Intermittent Incident"](#).

>> INSPECTION END

Component Inspection

INFOID:000000010584524

1.CHECK HEATED SEAT RELAY

- Turn ignition switch OFF.
- Disconnect heated seat relay.
- Check continuity between heated seat relay terminals.

Terminal	Condition	Continuity
6	12 V direct current supply between terminals 1 and 2.	Existed
7	No current supply	Not existed

Is the inspection result normal?

- YES >> INSPECTION END
 NO >> Replace heated seat relay.

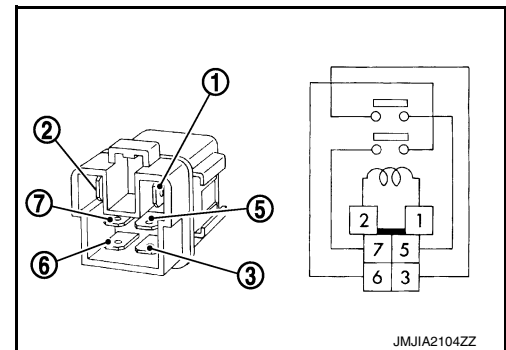

JMJIA2104ZZ

HEAT SENSOR

< DTC/CIRCUIT DIAGNOSIS >

HEAT SENSOR DRIVER SIDE

DRIVER SIDE : Description

INFOID:0000000010584525

Detects seat cushion heater temperature and outputs to heated seat control unit.

DRIVER SIDE : Component Function Check

INFOID:0000000010584526

1. CHECK FUNCTION

Check that heated seat warms to preset temperature when operating heated seat switch to the optimal position.

Is the inspection result normal?

- YES >> Heat sensor function is OK.
NO >> Refer to [SE-44, "Diagnosis Procedure"](#)

DRIVER SIDE : Diagnosis Procedure

INFOID:0000000010584527

1. CHECK HEAT SENSOR INPUT SIGNAL

1. Turn ignition switch ON.
2. Check voltage between heated seat control unit harness connector and ground.

(+) Heated seat control unit		(-)	Condition	Voltage (V)
Connector	Terminal			
B439	69	Ground	OFF	0
			1 (Min. temperature)	10.87 – 11.02
			2	10.93 – 11.07
			3	11.04 – 11.17
			4	11.13 – 11.26
			5	11.22 – 11.34
			6 (Max. temperature)	11.31 – 11.43

NOTE:

Voltage is repeated within the value shown as per the following list depending on heater unit temperature.

Is the inspection result normal?

- YES >> Heat sensor function is OK.
NO >> GO TO 2.

2. CHECK HEAT SENSOR CIRCUIT

1. Turn ignition switch OFF.
2. Disconnect heated seat control unit connector and seat cushion heater connector.
3. Check continuity between heated seat control unit harness connector and seat cushion heater harness connector.

Heated seat control unit		Seat cushion heater		Continuity
Connector	Terminal	Connector	Terminal	
B439	69	B440	69	Existed

4. Check continuity between heated seat control unit harness connector and ground.

Heated seat control unit		Ground	Continuity
Connector	Terminal		
B439	69		Not existed

Is the inspection result normal?

HEAT SENSOR

< DTC/CIRCUIT DIAGNOSIS >

- YES >> GO TO 3.
NO >> Repair or replace harness.

3.CHECK HEAT SENSOR POWER SUPPLY

1. Turn ignition switch ON.
2. Check voltage between seat cushion heater harness connector and ground.

(+)		(-)	Voltage (V) (Approx.)
Seat cushion heater			
Connector	Terminal		
B440	66	Ground	Battery voltage

Is the inspection result normal?

- YES >> GO TO 5.
NO >> GO TO 4.

4.CHECK HEAT SENSOR POWER SUPPLY CIRCUIT

1. Turn ignition switch OFF.
2. Disconnect heated seat switch connector.
3. Check continuity between heated seat control unit harness connector and seat cushion heater harness connector.

Heated seat switch		Seat cushion heater		Continuity
Connector	Terminal	Connector	Terminal	
M172	1	B440	66	Existed

4. Check continuity between heated seat control unit harness connector and ground.

Heated seat switch		Ground	Continuity
Connector	Terminal		Not existed
M172	1		

Is the inspection result normal?

- YES >> GO TO 6.
NO >> Repair or replace harness.

5.CHECK HEAT SENSOR

Check heat sensor. Refer to [SE-47, "DRIVER SIDE : Component Inspection"](#).

Is the inspection result normal?

- YES >> GO TO 6.
NO >> Replace seat cushion heater. Refer to [SE-122, "Exploded View"](#).

6.CHECK INTERMITTENT INCIDENT

Check intermittent incident.
Refer to [GI-47, "Intermittent Incident"](#).

>> INSPECTION END

DRIVER SIDE : Component Inspection

INFOID:000000010584528

1.CHECK HEAT SENSOR

1. Turn ignition switch OFF.
2. Disconnect seat cushion heater connector.
3. Check resistance between seat cushion heater terminals as follows.

HEAT SENSOR

< DTC/CIRCUIT DIAGNOSIS >

Seat cushion heater		Condition	Resistance (KΩ)
Terminal			
66	69	When heat sensor temperature is 25°C (77°F)	9.9 – 10.1

NOTE:

Resistance value changes according to temperature.

Is the inspection result normal?

YES >> INSPECTION END

NO >> Replace seat cushion heater. Refer to [SE-122, "Exploded View"](#).

PASSENGER SIDE

PASSENGER SIDE : Description

INFOID:000000010584529

Detects seat cushion heater temperature and outputs to heated seat control unit.

PASSENGER SIDE : Component Function Check

INFOID:000000010584530

1.CHECK HEATER SENSOR FUNCTION

Check that heated seat warms to preset temperature when operating heated seat switch to the optimal position.

Is the inspection result normal?

YES >> Heat sensor function is OK.

NO >> Refer to [SE-44, "Diagnosis Procedure"](#)

PASSENGER SIDE : Diagnosis Procedure

INFOID:000000010584531

1.CHECK HEAT SENSOR INPUT SIGNAL

1. Turn ignition switch ON.
2. Check voltage between heated seat control unit harness connector and ground.

(+)		(-)	Condition	Voltage (V)
Heated seat control unit				
Connector	Terminal			
B462	69	Ground	OFF	0
			1 (Min. temperature)	10.87 – 11.02
			2	10.93 – 11.07
			3	11.04 – 11.17
			4	11.13 – 11.26
			5	11.22 – 11.34
			6 (Max. temperature)	11.31 – 11.43

NOTE:

Voltage is repeated within the value shown as per the following list depending on heater unit temperature.

Is the inspection result normal?

YES >> heat sensor function is OK.

NO >> GO TO 2.

2.CHECK HEAT SENSOR CIRCUIT

1. Turn ignition switch OFF.
2. Disconnect heated seat control unit connector and seat cushion heater connector.
3. Check continuity between heated seat control unit harness connector and seat cushion heater harness connector.

HEAT SENSOR

< DTC/CIRCUIT DIAGNOSIS >

Heated seat control unit		Seat cushion heater		Continuity
Connector	Terminal	Connector	Terminal	
B462	69	B463	69	Existed

4. Check continuity between heated seat control unit harness connector and ground.

Heated seat control unit		Ground	Continuity
Connector	Terminal		
B462	69		Not existed

Is the inspection result normal?

YES >> GO TO 3.

NO >> Repair or replace harness.

3.CHECK HEAT SENSOR POWER SUPPLY

- Turn ignition switch ON.
- Check voltage between seat cushion heater harness connector and ground.

(+)		(-)	Voltage (V) (Approx.)
Seat cushion heater			
Connector	Terminal		
B463	66	Ground	Battery voltage

Is the inspection result normal?

YES >> GO TO 5.

NO >> GO TO 4.

4.CHECK HEAT SENSOR POWER SUPPLY CIRCUIT

- Turn ignition switch OFF.
- Disconnect heated seat switch connector.
- Check continuity between heated seat control unit harness connector and seat cushion heater harness connector.

Heated seat switch		Seat cushion heater		Continuity
Connector	Terminal	Connector	Terminal	
M173	1	B463	66	Existed

4. Check continuity between heated seat control unit harness connector and ground.

Heated seat switch		Ground	Continuity
Connector	Terminal		
M173	1		Not existed

Is the inspection result normal?

YES >> GO TO 6.

NO >> Repair or replace harness.

5.CHECK HEAT SENSOR

Check heat sensor. Refer to [SE-50. "PASSENGER SIDE : Component Inspection"](#).

Is the inspection result normal?

YES >> GO TO 6.

NO >> Replace seat cushion heater. Refer to [SE-122. "Exploded View"](#).

6.CHECK INTERMITTENT INCIDENT

Check intermittent incident.

Refer to [GI-47. "Intermittent Incident"](#).

HEAT SENSOR

< DTC/CIRCUIT DIAGNOSIS >

>> INSPECTION END

PASSENGER SIDE : Component Inspection

INFOID:0000000010584532

1. CHECK HEAT SENSOR

1. Turn ignition switch OFF.
2. Disconnect seat cushion heater connector.
3. Check resistance between seat cushion heater terminals as follows.

Seat cushion heater		Condition	Resistance (KΩ)
Terminal			
66	69	When heat sensor temperature is 25°C (77°F)	9.9 – 10.1

NOTE:

Resistance value changes according to temperature.

Is the inspection result normal?

YES >> INSPECTION END

NO >> Replace seat cushion heater. Refer to [SE-122. "Exploded View"](#).

SEAT CUSHION HEATER

< DTC/CIRCUIT DIAGNOSIS >

SEAT CUSHION HEATER DRIVER SIDE

DRIVER SIDE : Description

INFOID:0000000010584533

Warms the seat cushion.

DRIVER SIDE : Component Function Check

INFOID:0000000010584534

1.CHECK SEAT CUSHION HEATER FUNCTION

Check that heated seat warms to preset temperature when operating heated seat switch to the optimal position.

Is the inspection result normal?

YES >> Seat cushion heater function is OK.

NO >> Refer to [SE-51, "DRIVER SIDE : Diagnosis Procedure"](#).

DRIVER SIDE : Diagnosis Procedure

INFOID:0000000010584535

1.CHECK SEAT CUSHION HEATER INPUT SIGNAL

1. Turn ignition switch OFF.
2. Disconnect seat cushion heater connector.
3. Turn ignition switch ON.
4. Check voltage between seat cushion heater harness connector and ground.

(+)		(-)	Condition	Voltage (V)	
Seat cushion heater					
Connector	Terminal				
B440	68	Ground	Heated seat	Operated	0 – Battery voltage
				Other than the above	0

NOTE:

Voltage is repeated within the value shown as per the following list depending on heater unit temperature.

Is the inspection result normal?

YES >> GO TO 3.

NO >> GO TO 2.

2.CHECK SEAT CUSHION HEATER CIRCUIT

1. Turn ignition switch OFF.
2. Disconnect heated seat control unit connector.
3. Check continuity between seat cushion heater harness connector and heated seat control unit harness connector.

Seat cushion heater		Heated seat control unit		Continuity
Connector	Terminal	Connector	Terminal	
B440	68	B439	68	Existed

4. Check continuity between seat cushion heater harness connector and ground.

Seat cushion heater		Ground	Continuity
Connector	Terminal		
B440	68		Not existed

Is the inspection result normal?

YES >> Replace heated seat control unit. Refer to [SE-150, "Removal and Installation"](#).

NO >> Repair or replace harness.

3.CHECK SEAT CUSHION HEATER

SEAT CUSHION HEATER

< DTC/CIRCUIT DIAGNOSIS >

Check seat cushion heater.

Refer to [SE-52, "DRIVER SIDE : Component Inspection"](#).

Is the inspection result normal?

YES >> GO TO 4.

NO >> Replace seat cushion heater. Refer to [SE-122, "Exploded View"](#).

4.CHECK SEAT CUSHION HEATER GROUND CIRCUIT

Check continuity between seat cushion heater harness connector and ground.

Seat cushion heater		Ground	Continuity
Connector	Terminal		Existed
B440	59		

Is the inspection result normal?

YES >> GO TO 5.

NO >> Repair or replace harness.

5.CHECK INTERMITTENT INCIDENT

Check intermittent incident.

Refer to [GI-47, "Intermittent Incident"](#).

>> INSPECTION END

DRIVER SIDE : Component Inspection

INFOID:0000000010584536

1.CHECK SEAT CUSHION HEATER

1. Turn ignition switch OFF.
2. Disconnect seat cushion heater connector and seatback heater connector.
3. Check resistance between seat cushion heater terminals as follows.

Seat cushion heater		Condition	Resistance (Ω)
Terminal			2.6 – 3.0
59	68	When heat sensor temperature is 20°C (68°F)	

NOTE:

Resistance value changes according to temperature.

Is the inspection result normal?

YES >> INSPECTION END

NO >> Replace seat cushion heater. Refer to [SE-122, "Exploded View"](#).

PASSENGER SIDE

PASSENGER SIDE : Description

INFOID:0000000010584537

Warms the seat cushion.

PASSENGER SIDE : Component Function Check

INFOID:0000000010584538

1.CHECK SEAT CUSHION HEATER FUNCTION

Check that heated seat warms to preset temperature when operating heated seat switch to the optimal position.

Is the inspection result normal?

YES >> Seat cushion heater function is OK.

NO >> Refer to [SE-52, "PASSENGER SIDE : Diagnosis Procedure"](#).

PASSENGER SIDE : Diagnosis Procedure

INFOID:0000000010584539

1.CHECK FRONT SEAT CUSHION HEATER INPUT SIGNAL

SEAT CUSHION HEATER

< DTC/CIRCUIT DIAGNOSIS >

1. Turn ignition switch OFF.
2. Disconnect seat cushion heater connector.
3. Turn ignition switch ON.
4. Check voltage between seat cushion heater harness connector and ground.

(+)		(-)	Condition	Voltage (V)
Connector	Terminal			
B463	68	Ground	Heated seat	0 – Battery voltage
			Operated	0
			Other than the above	0

NOTE:

Voltage is repeated within the value shown as per the following list depending on heater unit temperature.

Is the inspection result normal?

- YES >> GO TO 3.
 NO >> GO TO 2.

2.CHECK SEAT CUSHION HEATER CIRCUIT

1. Turn ignition switch OFF.
2. Disconnect heated seat control unit connector.
3. Check continuity between seat cushion heater harness connector and heated seat control unit harness connector.

Seat cushion heater		Heated seat control unit		Continuity
Connector	Terminal	Connector	Terminal	
B463	68	B462	68	Existed

4. Check continuity between seat cushion heater harness connector and ground.

Seat cushion heater		Ground	Continuity
Connector	Terminal		
B463	68		Not existed

Is the inspection result normal?

- YES >> Replace heated seat control unit. Refer to [SE-150. "Removal and Installation"](#).
 NO >> Repair or replace harness.

3.CHECK SEAT CUSHION HEATER

Check seat cushion heater.
 Refer to [SE-54. "PASSENGER SIDE : Component Inspection"](#).

Is the inspection result normal?

- YES >> GO TO 4.
 NO >> Replace seat cushion heater. Refer to [SE-122. "Exploded View"](#).

4.CHECK SEAT CUSHION HEATER GROUND CIRCUIT

1. Turn ignition switch OFF.
2. Check continuity between seat cushion heater harness connector and ground.

Seat cushion heater		Ground	Continuity
Connector	Terminal		
B463	59		Existed

Is the inspection result normal?

- YES >> GO TO 5.
 NO >> Repair or replace harness.

5.CHECK INTERMITTENT INCIDENT

Check intermittent incident.

SEAT CUSHION HEATER

< DTC/CIRCUIT DIAGNOSIS >

Refer to [GI-47, "Intermittent Incident"](#).

>> INSPECTION END

PASSENGER SIDE : Component Inspection

INFOID:0000000010584540

1. CHECK SEAT CUSHION HEATER

1. Turn ignition switch OFF.
2. Disconnect seat cushion heater connector and seatback heater connector.
3. Check resistance between seat cushion heater terminals as follows.

Seat cushion heater		Condition	Resistance (Ω)
Terminal			
59	68	When heat sensor temperature is 20°C (68°F)	2.6 – 3.0

NOTE:

Resistance value changes according to temperature.

Is the inspection result normal?

YES >> INSPECTION END

NO >> Replace seat cushion heater. Refer to [SE-122, "Exploded View"](#).

SEATBACK HEATER

< DTC/CIRCUIT DIAGNOSIS >

SEATBACK HEATER DRIVER SIDE

DRIVER SIDE : Description

INFOID:0000000010584541

Warms the seat back heater.

DRIVER SIDE : Component Function Check

INFOID:0000000010584542

1. CHECK SEATBACK HEATER FUNCTION

Check that heated seat warms to preset temperature when operating heated seat switch to the optimal position.

Is the inspection result normal?

- YES >> Seatback heater function is OK.
- NO >> Refer to [SE-55, "DRIVER SIDE : Diagnosis Procedure"](#).

DRIVER SIDE : Diagnosis Procedure

INFOID:0000000010584543

1. CHECK SEATBACK HEATER

1. Turn ignition switch OFF.
2. Disconnect seatback heater connector.
3. Check resistance between seatback heater terminals.

Seatback heater			Condition	Resistance (Ω)
Connector	Terminal			
B442	1	2	When heat sensor temperature is 20°C (68°F)	4.0 – 4.7

NOTE:

Resistance value changes according to temperature.

Is the inspection result normal?

- YES >> Replace seat cushion heater. Refer to [SE-122, "Exploded View"](#).
- NO >> Replace seatback heater. Refer to [SE-122, "Exploded View"](#).

PASSENGER SIDE

PASSENGER SIDE : Description

INFOID:0000000010584544

Warms the seat back heater.

PASSENGER SIDE : Component Function Check

INFOID:0000000010584545

1. CHECK SEATBACK HEATER FUNCTION

Check that heated seat warms to preset temperature when operating heated seat switch to the optimal position.

Is the inspection result normal?

- YES >> Seatback heater function is OK.
- NO >> Refer to [SE-55, "PASSENGER SIDE : Diagnosis Procedure"](#).

PASSENGER SIDE : Diagnosis Procedure

INFOID:0000000010584546

1. CHECK SEATBACK HEATER

1. Turn ignition switch OFF.
2. Disconnect seatback heater connector.
3. Check resistance between seatback heater terminals.

SEATBACK HEATER

< DTC/CIRCUIT DIAGNOSIS >

Seatback heater			Condition	Resistance (Ω)
Connector	Terminal			
B465	1	2	When heat sensor temperature is 20°C (68°F)	4.0 – 4.7

NOTE:

Resistance value changes according to temperature.

Is the inspection result normal?

- YES >> Replace seat cushion heater. Refer to [SE-122, "Exploded View"](#).
NO >> Replace seatback heater. Refer to [SE-122, "Exploded View"](#).

HEATED SEAT SWITCH INDICATOR

< DTC/CIRCUIT DIAGNOSIS >

HEATED SEAT SWITCH INDICATOR DRIVER SIDE

DRIVER SIDE : Description

INFOID:000000010584547

Illuminates the indicator that indicates the operating status of heated seat.

DRIVER SIDE : Component Function Check

INFOID:000000010584548

1.CHECK HEATED SEAT SWITCH INDICATOR FUNCTION

Check that the related indicator lamp illuminates when heated seat switch is turned ON.

Is the inspection result normal?

- YES >> Heated seat switch indicator function is OK.
- NO >> Refer to [SE-57. "DRIVER SIDE : Diagnosis Procedure"](#).

DRIVER SIDE : Diagnosis Procedure

INFOID:000000010584549

1.CHECK HEATED SEAT SWITCH INDICATOR GROUND CIRCUIT

1. Turn ignition switch OFF
2. Disconnect heated seat switch connector.
3. Check continuity between heated seat switch harness connector and ground.

Heated seat switch		Ground	Continuity
Connector	Terminal		
M172	6		Existed

Is the inspection result normal?

- YES >> GO TO 2.
- NO >> Repair or replace harness.

2.CHECK HEATED SEAT SWITCH

Check heated seat switch.

Refer to [SE-57. "DRIVER SIDE : Component Inspection"](#).

Is the inspection result normal?

- YES >> GO TO 3.
- NO >> Replace heated seat switch. Refer to [SE-151. "Removal and Installation"](#).

3.CHECK INTERMITTENT INCIDENT

Check intermittent incident.

Refer to [GI-47. "Intermittent Incident"](#).

>> INSPECTION END

DRIVER SIDE : Component Inspection

INFOID:000000010584550

1.CHECK HEATED SEAT SWITCH

1. Turn ignition OFF.
2. Disconnect heated seat switch connector.
3. Set the heated seat switch ON.
4. Check continuity between heated seat switch terminals as follows.

Heated seat switch		Continuity
Terminal		
(+)*	(-)*	
5	6	Existed
6	5	Not existed

HEATED SEAT SWITCH INDICATOR

< DTC/CIRCUIT DIAGNOSIS >

*For a digital tester.

NOTE:

- Use a tester that can perform LED (light-emitting diode) measurement.
- The polarity (+ and -) reverses when checking using an analog tester.

Is the inspection result normal?

YES >> INSPECTION END

NO >> Replace heated seat switch. Refer to [SE-151, "Removal and Installation"](#).

PASSENGER SIDE

PASSENGER SIDE : Description

INFOID:0000000010584551

Illuminates the indicator that indicates the operating status of heated seat.

PASSENGER SIDE : Component Function Check

INFOID:0000000010584552

1.CHECK FUNCTION

Check that the related indicator lamp illuminates when heated seat switch is turned ON.

Is the inspection result normal?

YES >> Heated seat switch indicator function is OK.

NO >> Refer to [SE-58, "PASSENGER SIDE : Diagnosis Procedure"](#).

PASSENGER SIDE : Diagnosis Procedure

INFOID:0000000010584553

1.CHECK HEATED SEAT SWITCH INDICATOR GROUND CIRCUIT

1. Turn ignition switch OFF
2. Disconnect heated seat switch connector.
3. Check continuity between heated seat switch harness connector and ground.

Heated seat switch		Ground	Continuity
Connector	Terminal		
M173	6		Existed

Is the inspection result normal?

YES >> GO TO 2.

NO >> Repair or replace harness.

2.CHECK HEATED SEAT SWITCH

Check heated seat switch.

Refer to [SE-58, "PASSENGER SIDE : Component Inspection"](#).

Is the inspection result normal?

YES >> GO TO 3.

NO >> Replace heated seat switch. Refer to [SE-151, "Removal and Installation"](#).

3.CHECK INTERMITTENT INCIDENT

Check intermittent incident.

Refer to [GI-47, "Intermittent Incident"](#).

>> INSPECTION END

PASSENGER SIDE : Component Inspection

INFOID:0000000010584554

1.CHECK HEATED SEAT SWITCH

1. Turn ignition OFF.
2. Disconnect heated seat switch connector.
3. Set the heated seat switch ON.
4. Check continuity between heated seat switch terminals.

HEATED SEAT SWITCH INDICATOR

< DTC/CIRCUIT DIAGNOSIS >

Heated seat switch		Continuity
Terminal		
(+)*	(-)*	
5	6	Existed
6	5	Not existed

*For a digital tester.

NOTE:

- Use a tester that can perform LED (light-emitting diode) measurement.
- The polarity (+ and -) reverses when checking using an analog tester.

Is the inspection result normal?

YES >> Heated seat switch is OK.

NO >> Replace heated seat switch. Refer to [SE-151, "Removal and Installation"](#).

A
B
C
D
E
F
G
H
I
K
L
M
N
O
P

SE

POWER SEAT

< DTC/CIRCUIT DIAGNOSIS >

POWER SEAT

Wiring Diagram - POWER SEAT FOR DRIVER SIDE (WITHOUT AUTOMATIC DRIVE POSITIONER) -

INFOID:000000010584555

POWER SEAT FOR DRIVER SIDE (WITHOUT AUTOMATIC DRIVE POSITIONER)

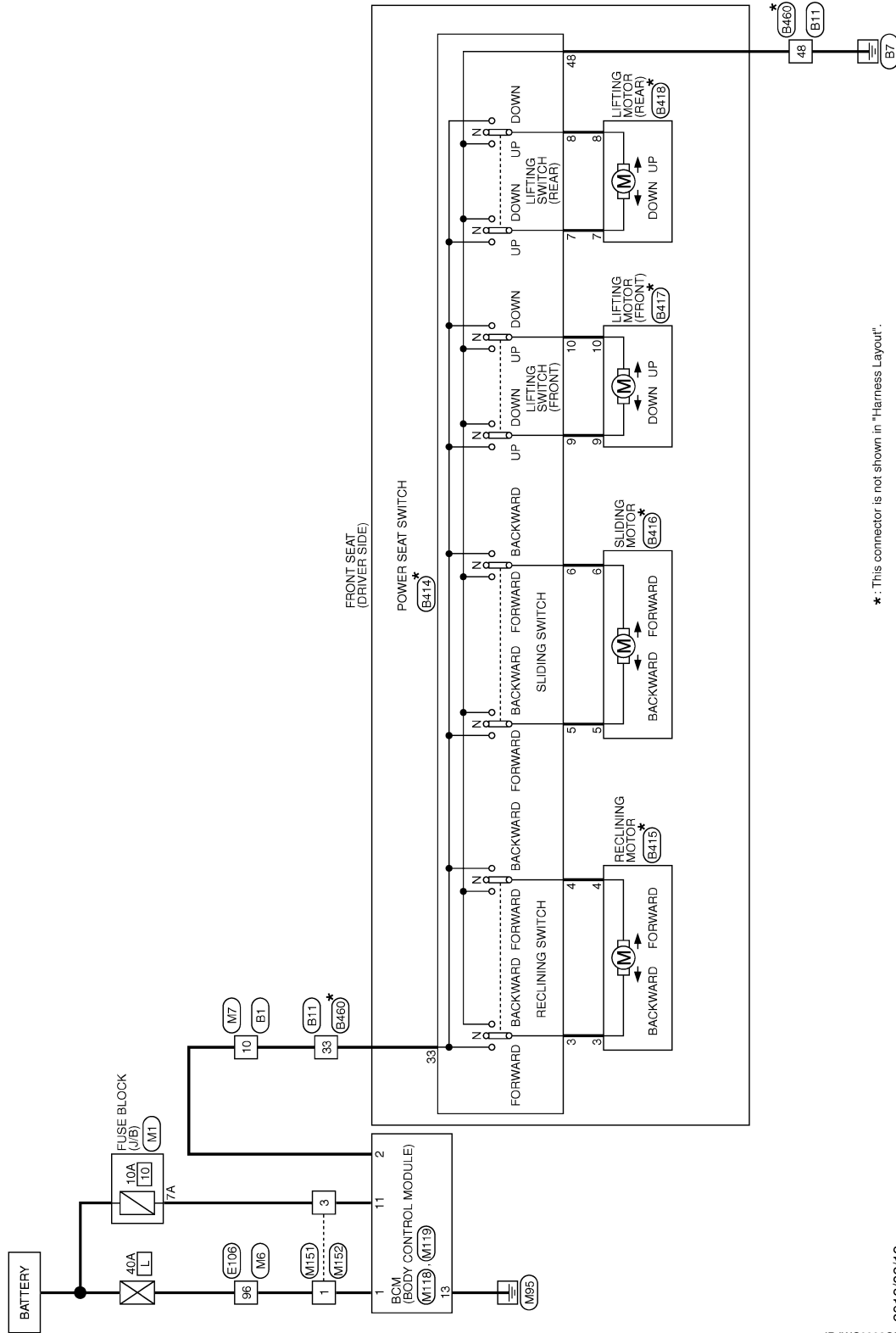

*: This connector is not shown in "Harness Layout".

JR.JWC0923GB
2013/02/13

POWER SEAT

< DTC/CIRCUIT DIAGNOSIS >

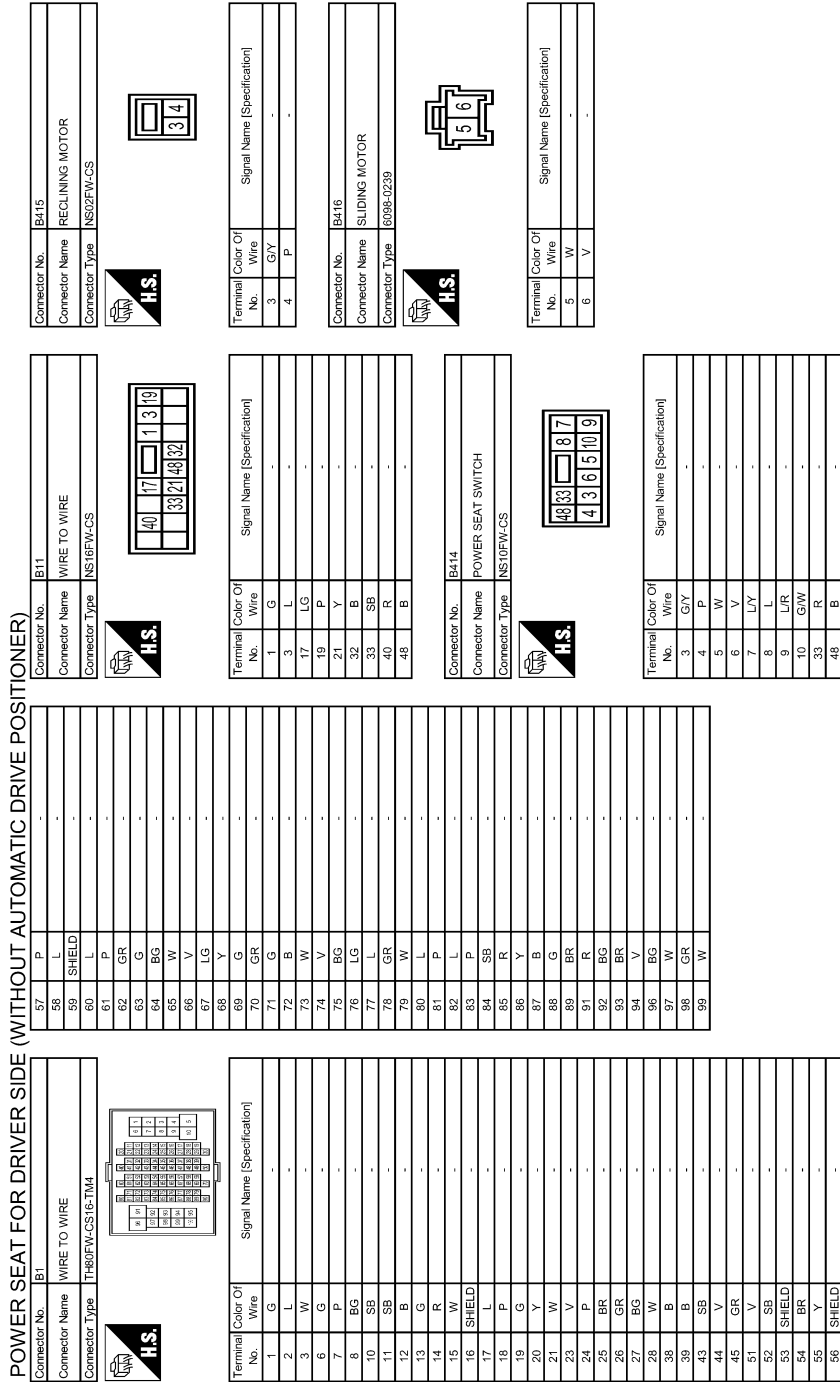

A
B
C
D
E
F
G
H
I
SE
K
L
M
N
O
P

POWER SEAT

< DTC/CIRCUIT DIAGNOSIS >

POWER SEAT FOR DRIVER SIDE (WITHOUT AUTOMATIC DRIVE POSITIONER)

Connector No.	B417
Connector Name	LIFTING MOTOR (FRONT)
Connector Type	NS02FW-CS



Terminal No.	Wire	Signal Name [Specification]
9	L/R	-
10	G/W	-

Connector No.	B418
Connector Name	LIFTING MOTOR (REAR)
Connector Type	NS02FW-CS

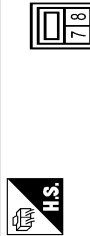

Terminal No.	Wire	Signal Name [Specification]
7	L/Y	-
8	L	-

Connector No.	B460
Connector Name	WIRE TO WIRE
Connector Type	NS16MW-LC



Terminal No.	Wire	Signal Name [Specification]
1	L/W	-
3	R/Y	-
17	Y/R	-
19	V	-
21	L/Y	-
32	B/W	-
40	R/W	-
48	B	-

Connector No.	E106
Connector Name	WIRE TO WIRE
Connector Type	TH80FW-CS16-TM4



Terminal No.	Wire	Signal Name [Specification]
1	G	-
2	B/G	-
3	SB	-
4	L/G	-
5	Y	-
6	W	-
7	G	-
8	V	-
9	R	-
10	BR	-
11	B	-

12	G	-
13	R	-
14	W	-
15	SHIELD	-
16	SB	-
17	L	-
18	P	-
19	G	-
20	W	- [With ICC]
20	Y	- [Without ICC]
21	BR	-
22	R	- [With ICC]
22	V	- [Without ICC]
23	G	-
24	L	- [With ICC]
24	P	- [Without ICC]
25	L	- [With ICC]
25	Y	- [Without ICC]
26	SHIELD	-
28	G	-
29	LG	-
30	B/G	-
32	W	-
33	Y	-
34	B/G	-
37	Y	-
38	GR	-
39	LG	-
41	LG	-
42	V	-
43	R	-
44	G	-
45	GR	-
46	W	-
47	L	-
48	P	-
49	SB	-
50	BR	-
51	B	-
52	Y	-
53	B/G	-
54	R	-
55	SB	-
59	P	-
60	SB	-
61	V	-
62	P	-
63	LG	-
64	L	-
65	B/G	-

69	L	-
70	SHIELD	-
71	G	-
72	G	-
73	R	-
74	BR	-
76	L	-
77	W	-
78	Y	-
80	SB	-
81	L	-
82	W	-
83	LG	-
84	GR	-
85	G	-
86	P	-
87	W	-
88	B/G	-
89	LG	-
90	BR	-
91	GR	-
92	BR	-
93	SB	-
95	Y	-
96	W	-
97	W	-
98	SHIELD	-
100	Y	-

Connector No.	M1
Connector Name	FUSE BLOCK (J/B)
Connector Type	NS08FM-M2

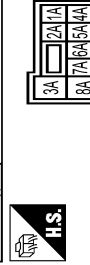

Terminal No.	Wire	Signal Name [Specification]
1A	B/G	-
2A	G	-
3A	L	-
4A	R	-
5A	V	-
6A	Y	-

POWER SEAT

< DTC/CIRCUIT DIAGNOSIS >

POWER SEAT FOR DRIVER SIDE (WITHOUT AUTOMATIC DRIVE POSITIONER)		WITHOUT AUTOMATIC DRIVE POSITIONER					
Terminal No.	Color Of Wire	Terminal No.	Color Of Wire	Terminal No.	Color Of Wire	Terminal No.	Color Of Wire
7A	R	28	GR	90	P	38	B
8A	L	29	V	91	R	39	B
		30	BG	92	R	43	SB
		32	W	93	GR	44	W
		33	Y	95	G	45	B
		34	L	96	W	51	V
		37	G	97	W	52	LG
		38	R	98	SHIELD	53	SHIELD
		39	G	100	Y	54	BR
		41	L			55	Y
		42	W			56	SHIELD
		43	R			57	P
		44	LG			58	L
		45	GR			59	SHIELD
		46	W			60	L
		47	L			61	BR
		48	P			62	R
		49	BG			63	Y
		50	LG			64	L
		51	SB			65	W
		52	Y			66	W
		53	BG			67	LG
		54	BR			68	Y
		55	SB			69	G
		59	SB			70	V
		60	SB			71	W
		61	V			72	B
		62	P			73	W
		63	R			74	LG
		64	L			75	P
		65	BG			76	LG
		69	V			77	SB
		70	SHIELD			78	GR
		71	BG			79	R
		72	GR			80	L
		73	W			81	P
		74	SB			82	L
		76	V			83	P
		77	V			84	SB
		78	Y			85	W
		80	BG			86	Y
		81	L			87	B
		82	W			88	G
		83	Y			89	BG
		84	Y			91	R
		85	P			92	BG
		86	BR			93	BR
		87	P			94	V
		88	V			96	BG
		89	G			97	W

Terminal No.	Color Of Wire	Signal Name [Specification]
1	G	- [Without ICC]
2	BG	- [With ICC]
3	LG	- [Without Auto aircon seat]
4	SB	- [With Auto aircon seat]
5	GR	-
6	W	-
7	G	-
8	W	-
9	P	-
10	BR	-
11	B	-
12	G	-
13	R	-
14	W	-
15	SHIELD	-
16	BR	-
17	L	-
18	P	-
19	G	- [Without ICC]
20	GR	- [With ICC]
20	W	- [With ICC]
21	BR	- [Without ICC]
21	R	- [With ICC]
22	L	- [Without ICC]
22	R	- [With ICC]
23	C	- [With ICC]
24	L	- [Without ICC]
24	B	- [With ICC]
25	W	- [Without ICC]
25	Y	- [With ICC]
26	SHIELD	-

Terminal No.	Color Of Wire	Signal Name [Specification]
1	G	- [With Auto aircon seat]
2	B	- [Without Auto aircon seat]
3	W	-
6	P	-
7	V	-
8	BG	-
10	W	-
11	BG	-
12	B	-
13	G	-
14	R	-
15	W	-
16	SHIELD	-
17	L	-
18	R	-
19	G	-
19	W	-
16	SHIELD	-
17	L	-
18	P	-
19	G	-
20	R	-
20	L	-
21	LG	-
22	V	-
22	P	-
25	BR	-
26	GR	-
27	BG	-
28	W	-

Terminal No.	Color Of Wire	Signal Name [Specification]
1	G	- [With Auto aircon seat]
2	B	- [Without Auto aircon seat]
3	W	-
6	P	-
7	V	-
8	BG	-
10	W	-
11	BG	-
12	B	-
13	G	-
14	R	-
15	W	-
16	SHIELD	-
17	L	-
18	R	-
19	G	-
19	W	-
16	SHIELD	-
17	L	-
18	P	-
19	G	-
20	R	-
20	L	-
21	LG	-
22	V	-
22	P	-
25	BR	-
26	GR	-
27	BG	-
28	W	-

Connector No.	WIRE TO WIRE
M6	
WIRE TO WIRE	
Connector Name	TH80MW-CS16-TM4
Connector Type	

Connector No.	WIRE TO WIRE
M7	
WIRE TO WIRE	
Connector Name	TH80MW-CS16-TM4
Connector Type	

Terminal No.	Color Of Wire	Signal Name [Specification]
38	B	-
39	B	-
43	SB	-
44	W	-
45	B	-
51	V	-
52	LG	-
53	SHIELD	-
54	BR	-
55	Y	-
56	SHIELD	-
57	P	-
58	L	-
59	SHIELD	-
60	L	-
61	BR	-
62	R	-
63	Y	-
64	L	-
65	W	-
66	W	-
67	LG	-
68	Y	-
69	G	-
70	V	-
71	W	-
72	B	-
73	W	-
74	LG	-
75	P	-
76	LG	-
77	SB	-
78	GR	-
79	R	-
80	L	-
81	P	-
82	L	-
83	P	-
84	SB	-
85	W	-
86	Y	-
87	B	-
88	G	-
89	BG	-
91	R	-
92	BG	-
93	BR	-
94	V	-
96	BG	-
97	W	-

JRJWC5564GB

A
B
C
D
E
F
G
H
I
SE
K
L
M
N
O
P

POWER SEAT

< DTC/CIRCUIT DIAGNOSIS >

POWER SEAT FOR DRIVER SIDE (WITHOUT AUTOMATIC DRIVE POSITIONER)

98	R	-
99	BG	-

Connector No.	M118
Connector Name	BCM (BODY CONTROL MODULE)
Connector Type	M03FE-LC



Terminal No.	Color Of Wire	Signal Name [Specification]
1	W	BAT (FIL)
2	Y	POWER WINDOW POWER SUPPLY (BAT)
3	BG	POWER WINDOW POWER SUPPLY (RAMP)

Connector No.	M119
Connector Name	BCM (BODY CONTROL MODULE)
Connector Type	M16FW-CS



Terminal No.	Color Of Wire	Signal Name [Specification]
4	P	INT ROOM LAMP PWR SUPPLY (BAT SAVE)
5	V	PASSENGER DOOR UNLOCK OUTPUT
7	Y	STEP LAMP OUTPUT
8	V	ALL DOOR FUEL LID LOCK OUTPUT
9	G	DRIVER DOOR FUEL LID UNLOCK OUTPUT
10	BR	REAR DOOR UNLOCK OUTPUT
11	R	BAT (FALSE)
13	B	GROUND
15	Y	ACC IN0
17	W	TURN SIGNAL RH (FRONT)
18	BG	TURN SIGNAL LH (FRONT)
19	SB	ROOM LAMP TIMER

Connector No.	M151
Connector Name	WIRE TO WIRE
Connector Type	M03FW-LC



Terminal No.	Color Of Wire	Signal Name [Specification]
1	W	-
2	Y	-
3	R	-

Connector No.	M152
Connector Name	WIRE TO WIRE
Connector Type	M03MW-LC



Terminal No.	Color Of Wire	Signal Name [Specification]
1	W	-
2	Y	-
3	R	-

JRJWC5565GB

POWER SEAT

< DTC/CIRCUIT DIAGNOSIS >

Wiring Diagram - POWER SEAT FOR PASSENGER SIDE -

INFOID:000000010584556

POWER SEAT FOR PASSENGER SIDE

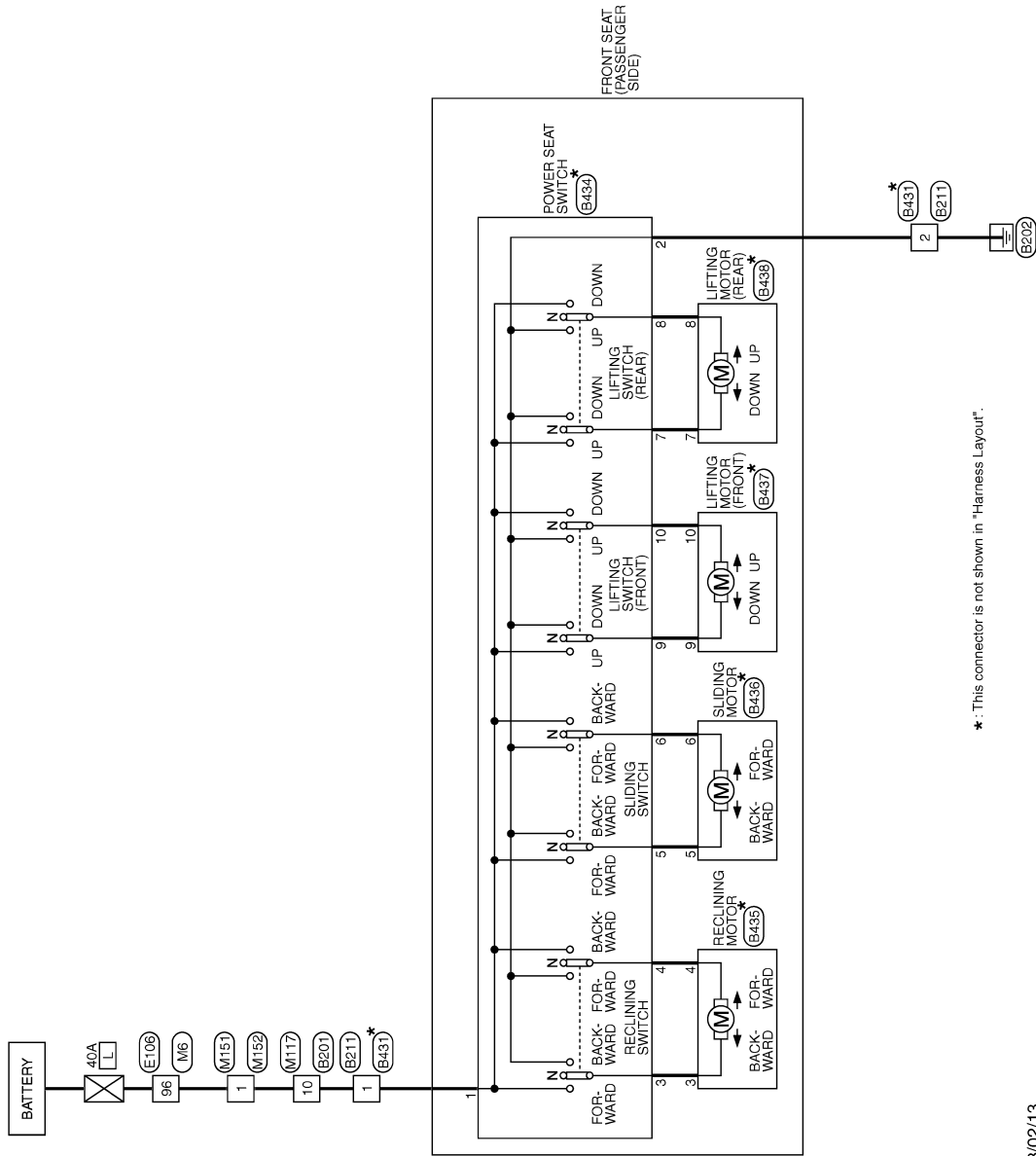

*: This connector is not shown in "Harness Layout".

2013/02/13

JRJWC0924GB

A
B
C
D
E
F
G
H
I
SE
K
L
M
N
O
P

POWER SEAT

< DTC/CIRCUIT DIAGNOSIS >

POWER SEAT FOR PASSENGER SIDE

Connector No.	B201
Connector Name	WIRE TO WIRE
Connector Type	TH89FW-CS16-TM4



Terminal No.	Color Of Wire	Signal Name [Specification]
1	G	-
2	R	-
3	BR	-
4	SB	-
5	BG	-
6	GR	-
7	W	-
8	W	-
10	G	-
11	SHIELD	-
20	L	-
21	P	-
22	GR	-
23	LG	-
24	W	-
25	V	-
26	G	-
27	Y	-
28	SHIELD	-
31	W	-
32	GR	-
33	SB	-
36	L	-
37	P	-
38	L	-
39	P	-
40	LG	- [With ICC] - [Without ICC]
41	SB	- [With ICC] - [Without ICC]
41	Y	- [With ICC] - [Without ICC]
42	V	- [With ICC] - [Without ICC]
43	B	- [With ICC] - [Without ICC]
43	BR	- [With ICC] - [Without ICC]
44	R	-
45	G	-

46	BG	- [With ICC] - [Without ICC]
46	SHIELD	- [With ICC] - [Without ICC]
47	B	- [With ICC] - [Without ICC]
47	L	- [With ICC] - [Without ICC]
48	P	- [With ICC] - [Without ICC]
48	R	- [With ICC] - [Without ICC]
49	G	- [With ICC] - [Without ICC]
49	W	- [With ICC] - [Without ICC]
50	SHIELD	-
51	W	-
52	R	-
53	G	-
54	L	-
55	SB	-
60	GR	-
61	LG	-
62	SB	-
63	P	-
64	BR	-
65	BG	-
66	Y	-
67	W	-
69	G	-
71	SB	-
72	V	-
73	LG	-
74	W	-
75	BR	-
76	V	-
77	LG	-
80	BG	-
82	P	-
83	Y	-
84	R	-
85	SB	-
86	GR	-
87	L	-
91	V	-
92	W	-
93	R	-
94	LG	-
95	GR	-
96	W	-
97	G	-
98	BG	-
99	L	-

Connector No.	B211
Connector Name	WIRE TO WIRE
Connector Type	M04FW-LC



Terminal No.	Color Of Wire	Signal Name [Specification]
1	G	-
2	B	-

Connector No.	B431
Connector Name	WIRE TO WIRE
Connector Type	M04MW-LC



Terminal No.	Color Of Wire	Signal Name [Specification]
1	R	-
2	B	-

Connector No.	B434
Connector Name	POWER SEAT SWITCH
Connector Type	NS10FW-CS

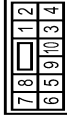

Terminal No.	Color Of Wire	Signal Name [Specification]
1	R	-
2	B	-
3	GY	-
4	P	-
5	W	-
6	V	-
7	LY	-
8	L	-
9	L/R	-
10	GW	-

Connector No.	B435
Connector Name	RECLINING MOTOR
Connector Type	NS02FW-CS



Terminal No.	Color Of Wire	Signal Name [Specification]
3	GY	-
4	P	-

POWER SEAT

< DTC/CIRCUIT DIAGNOSIS >

POWER SEAT FOR PASSENGER SIDE

Connector No.	B436
Connector Name	SLIDING MOTOR
Connector Type	6098-0239



Terminal No.	Wire	Signal Name [Specification]
5	W	-
6	V	-

Connector No.	B437
Connector Name	LIFTING MOTOR (FRONT)
Connector Type	NS02FM-CS



Terminal No.	Wire	Signal Name [Specification]
9	L/R	-
10	G/W	-

Connector No.	B438
Connector Name	LIFTING MOTOR (REAR)
Connector Type	NS02FM-CS



Terminal No.	Wire	Signal Name [Specification]
7	L/Y	-
8	L	-

Connector No.	E106
Connector Name	WIRE TO WIRE
Connector Type	TH80FM-CS16-TM4

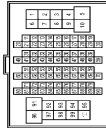

Terminal No.	Wire	Signal Name [Specification]
1	G	-
2	BG	-
3	SB	-
4	LG	-
5	Y	-
6	W	-
7	G	-
8	V	-
9	R	-
10	BR	-
11	B	-
12	G	-
13	R	-
14	W	-
15	SHIELD	-
16	SB	-
17	L	-
18	P	-

19	G	-
20	W	- [With ICC]
21	Y	- [Without ICC]
22	BR	-
23	R	- [With ICC]
24	V	- [Without ICC]
25	G	-
26	L	- [With ICC]
27	P	- [Without ICC]
28	L	- [With ICC]
29	Y	-
30	SHIELD	-
31	G	-
32	LG	-
33	BR	-
34	W	-
35	V	-
36	Y	-
37	BR	-
38	GR	-
39	LG	-
40	LG	-
41	V	-
42	V	-
43	R	-
44	G	-
45	GR	-
46	W	-
47	L	-
48	P	-
49	SB	-
50	BR	-
51	B	-
52	Y	-
53	BG	-
54	R	-
55	SB	-
56	P	-
57	V	-
58	W	-
59	P	-
60	SB	-
61	V	-
62	P	-
63	LG	-
64	L	-
65	BG	-
66	L	-
67	G	-
68	L	-
69	L	-
70	SHIELD	-
71	G	-
72	G	-
73	R	-
74	BR	-
75	L	-
76	L	-

77	W	-
78	Y	-
80	SB	-
81	L	-
82	W	-
83	LG	-
84	GR	-
85	G	-
86	P	-
87	W	-
88	BG	-
89	LG	-
90	BR	-
91	GR	-
92	BR	-
93	SB	-
95	Y	-
96	W	-
97	W	-
98	SHIELD	-
100	Y	-

Connector No.	M6
Connector Name	WIRE TO WIRE
Connector Type	TH80MW-CS16-TM4

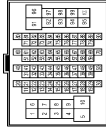

Terminal No.	Wire	Signal Name [Specification]
1	G	-
2	BG	-
3	LG	- [Without Auto aircon seat]
4	SB	- [With Auto aircon seat]
5	GR	-
6	W	-
7	G	-
8	W	-
9	B	-
10	BR	-
11	B	-
12	G	-

A
B
C
D
E
F
G
H
I
SE
K
L
M
N
O
P

POWER SEAT

< DTC/CIRCUIT DIAGNOSIS >

POWER SEAT FOR PASSENGER SIDE

13	R	-	-	-	-
14	W	-	-	-	-
15	SHIELD	-	-	-	-
16	BR	-	-	-	-
17	L	-	-	-	-
18	P	-	-	-	-
19	G	-	-	-	-
20	GR	-	-	-	-
20	W	-	-	-	-
21	BR	-	-	-	-
21	R	-	-	-	-
22	L	-	-	-	-
22	R	-	-	-	-
23	G	-	-	-	-
24	L	-	-	-	-
24	P	-	-	-	-
25	W	-	-	-	-
25	Y	-	-	-	-
26	SHIELD	-	-	-	-
28	GR	-	-	-	-
29	V	-	-	-	-
30	BG	-	-	-	-
32	W	-	-	-	-
33	Y	-	-	-	-
34	L	-	-	-	-
37	G	-	-	-	-
38	R	-	-	-	-
39	G	-	-	-	-
41	L	-	-	-	-
42	W	-	-	-	-
43	R	-	-	-	-
44	LG	-	-	-	-
45	GR	-	-	-	-
46	W	-	-	-	-
47	L	-	-	-	-
48	P	-	-	-	-
49	BG	-	-	-	-
50	LG	-	-	-	-
51	SB	-	-	-	-
52	Y	-	-	-	-
53	BG	-	-	-	-
54	BR	-	-	-	-
55	SB	-	-	-	-
59	SB	-	-	-	-
60	SB	-	-	-	-
61	V	-	-	-	-
62	P	-	-	-	-
63	R	-	-	-	-
64	L	-	-	-	-
65	BG	-	-	-	-

69	V	-	-	-	-
70	SHIELD	-	-	-	-
71	BG	-	-	-	-
72	GR	-	-	-	-
73	W	-	-	-	-
74	SB	-	-	-	-
76	V	-	-	-	-
77	V	-	-	-	-
78	Y	-	-	-	-
80	BG	-	-	-	-
81	L	-	-	-	-
82	W	-	-	-	-
83	Y	-	-	-	-
84	L	-	-	-	-
85	P	-	-	-	-
86	BR	-	-	-	-
87	P	-	-	-	-
88	V	-	-	-	-
89	G	-	-	-	-
90	P	-	-	-	-
91	R	-	-	-	-
92	R	-	-	-	-
93	GR	-	-	-	-
95	G	-	-	-	-
96	W	-	-	-	-
97	W	-	-	-	-
98	SHIELD	-	-	-	-
100	Y	-	-	-	-

Connector No.	M117
Connector Name	WIRE TO WIRE
Connector Type	TR180MW-CS16-TM4



Terminal No.	Color	Off Wire	Signal Name [Specification]
1	GR	-	-
2	BR	-	-
3	V	-	-
4	SB	-	-
6	Y	-	-
7	B	-	-

8	W	-	-	-	-
10	W	-	-	-	-
11	SHIELD	-	-	-	-
20	R	-	-	-	-
21	G	-	-	-	-
22	GR	-	-	-	-
23	V	-	-	-	-
24	W	-	-	-	-
25	R	-	-	-	-
26	P	-	-	-	-
27	L	-	-	-	-
28	SHIELD	-	-	-	-
31	W	-	-	-	-
32	W	-	-	-	-
33	SB	-	-	-	-
36	L	-	-	-	-
37	P	-	-	-	-
38	L	-	-	-	-
39	P	-	-	-	-
40	V	-	-	-	-
41	SB	-	-	-	-
41	Y	-	-	-	-
42	V	-	-	-	-
42	W	-	-	-	-
43	B	-	-	-	-
43	P	-	-	-	-
44	R	-	-	-	-
45	G	-	-	-	-
45	L	-	-	-	-
46	BG	-	-	-	-
46	SHIELD	-	-	-	-
47	B	-	-	-	-
47	L	-	-	-	-
48	P	-	-	-	-
48	R	-	-	-	-
49	G	-	-	-	-
49	W	-	-	-	-
50	SHIELD	-	-	-	-
51	BG	-	-	-	-
52	GR	-	-	-	-
53	G	-	-	-	-
54	L	-	-	-	-
55	P	-	-	-	-
60	LG	-	-	-	-
61	R	-	-	-	-
62	SB	-	-	-	-
63	V	-	-	-	-
64	Y	-	-	-	-
65	BR	-	-	-	-
66	BG	-	-	-	-

67	W	-	-	-	-
69	G	-	-	-	-
71	SB	-	-	-	-
72	V	-	-	-	-
73	V	-	-	-	-
74	LG	-	-	-	-
75	BR	-	-	-	-
76	V	-	-	-	-
77	LG	-	-	-	-
80	R	-	-	-	-
82	Y	-	-	-	-
83	BG	-	-	-	-
84	W	-	-	-	-
85	SB	-	-	-	-
86	B	-	-	-	-
87	P	-	-	-	-
81	L	-	-	-	-
82	L	-	-	-	-
83	G	-	-	-	-
84	BG	-	-	-	-
85	V	-	-	-	-
96	G	-	-	-	-
97	G	-	-	-	-
98	L	-	-	-	-
99	LG	-	-	-	-

Connector No.	M151
Connector Name	WIRE TO WIRE
Connector Type	MO3FW-LC



Terminal No.	Color	Off Wire	Signal Name [Specification]
1	W	-	-
2	Y	-	-
3	R	-	-

POWER SEAT

< DTC/CIRCUIT DIAGNOSIS >

A
B
C
D
E
F
G
H
I
SE
K
L
M
N
O
P

POWER SEAT FOR PASSENGER SIDE

Connector No.	M152
Connector Name	WIRE TO WIRE
Connector Type	MO3MMW-LC



Terminal No.	Color Of Wire	Signal Name [Specification]
1	W	-
2	Y	-
3	R	-

JRJWC5569GB

SIDE SUPPORT

< DTC/CIRCUIT DIAGNOSIS >

SIDE SUPPORT

Wiring Diagram - SIDE SUPPORT -

INFOID:000000010584557

SIDE SUPPORT

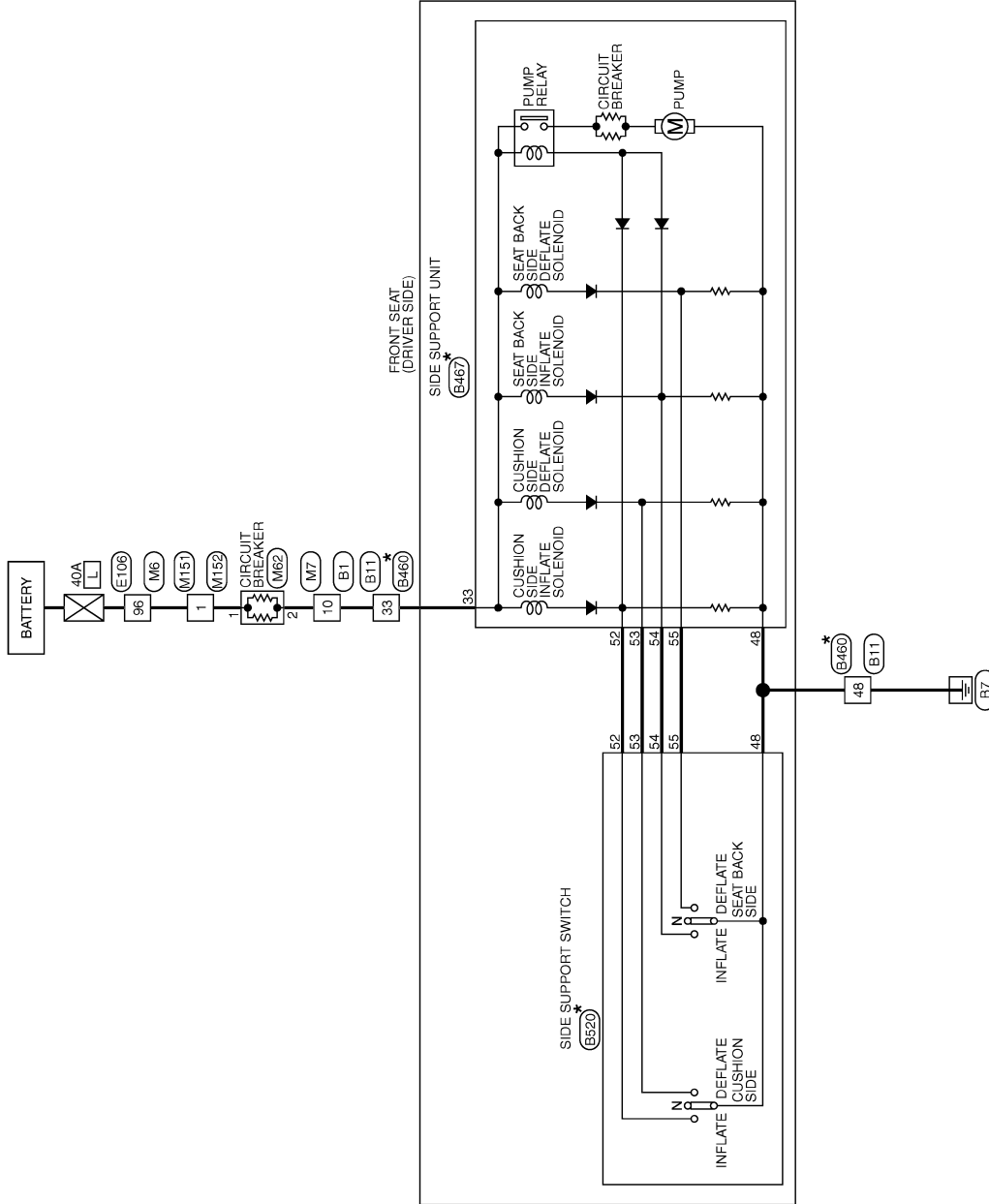

*: This connector is not shown in "Harness Layout".

2013/02/13

JRJWC0925GB

SIDE SUPPORT

< DTC/CIRCUIT DIAGNOSIS >

SIDE SUPPORT

Connector No.	B1
Connector Name	WIRE TO WIRE
Connector Type	TH80FM-CS1G-TM4



Terminal No.	Color Of Wire	Signal Name [Specification]
1	G	-
2	L	-
3	W	-
6	G	-
7	P	-
8	BG	-
10	SB	-
11	SB	-
12	B	-
13	G	-
14	R	-
15	W	-
16	SHIELD	-
17	L	-
18	P	-
19	G	-
20	Y	-
21	W	-
23	V	-
24	P	-
25	BR	-
26	GR	-
27	BG	-
28	W	-
38	B	-
39	B	-
43	SB	-
44	V	-
45	GR	-
51	V	-
52	SB	-
53	SHIELD	-
54	BR	-
55	Y	-
56	SHIELD	-

57	P	-
58	L	-
59	SHIELD	-
60	L	-
61	P	-
62	GR	-
63	G	-
64	BG	-
65	W	-
66	V	-
67	LG	-
68	Y	-
69	G	-
70	GR	-
71	G	-
72	B	-
73	W	-
74	V	-
75	BR	-
76	LG	-
77	L	-
78	GR	-
79	W	-
80	L	-
81	P	-
82	L	-
83	P	-
84	SB	-
85	R	-
86	Y	-
87	B	-
88	G	-
89	BR	-
91	R	-
92	BG	-
93	BR	-
94	V	-
96	BG	-
97	W	-
98	GR	-
99	W	-

Connector No.	B11
Connector Name	WIRE TO WIRE
Connector Type	NS16FM-CS

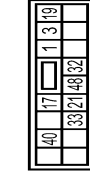

Terminal No.	Color Of Wire	Signal Name [Specification]
1	G	-
3	L	-
17	LG	-
18	P	-
21	Y	-
32	B	-
33	SB	-
40	R	-
48	B	-

Connector No.	B460
Connector Name	WIRE TO WIRE
Connector Type	NS16MW-LC



Terminal No.	Color Of Wire	Signal Name [Specification]
1	L/W	-
3	R/Y	-
17	Y/R	-
19	V	-
21	L/Y	-
32	B/W	-
33	R	-
40	R/W	-
48	B	-

Connector No.	B467
Connector Name	SIDE SUPPORT UNIT
Connector Type	NS08FM-CS



Terminal No.	Color Of Wire	Signal Name [Specification]
33	R	-
48	B	-
52	B	-
53	R	-
84	W	-
85	L	-

Connector No.	B620
Connector Name	SIDE SUPPORT SWITCH
Connector Type	NS08FM-CS

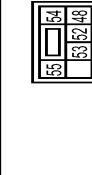

Terminal No.	Color Of Wire	Signal Name [Specification]
48	B	-
52	B	-
53	R	-
54	W	-
55	L	-

A
B
C
D
E
F
G
H
I
SE
K
L
M
N
O
P

SIDE SUPPORT

< DTC/CIRCUIT DIAGNOSIS >

SIDE SUPPORT

Connector No.	IE106
Connector Name	WIRE TO WIRE
Connector Type	TH801FW-CS16-TM4

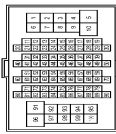

Terminal No.	Color Of Wire	Signal Name [Specification]
1	G	-
2	BG	-
3	LG	-
4	SB	-
5	Y	-
6	W	-
7	G	-
8	V	-
9	R	-
10	BR	-
11	B	-
12	G	-
13	R	-
14	W	-
15	SHIELD	-
16	SB	-
17	L	-
18	P	-
19	G	-
20	W	- [With ICC]
21	BR	- [Without ICC]
22	R	- [With ICC]
23	V	- [Without ICC]
24	L	- [With ICC]
25	L	- [Without ICC]
26	SHIELD	- [With ICC]
28	LG	-
29	LG	-
30	BG	-
32	W	-
33	Y	-
34	BG	-

37	Y	-
38	GR	-
39	LG	-
41	LG	-
42	V	-
43	R	-
44	G	-
45	GR	-
46	W	-
47	L	-
48	P	-
49	SB	-
50	BR	-
51	B	-
52	Y	-
53	BG	-
54	R	-
55	SB	-
58	P	-
60	SB	-
61	V	-
62	P	-
63	LG	-
64	L	-
65	BG	-
69	L	-
70	SHIELD	-
71	G	-
72	G	-
73	R	-
74	BR	-
76	L	-
77	W	-
78	Y	-
80	SB	-
81	L	-
82	W	-
83	LG	-
84	GR	-
85	G	-
86	P	- [With ICC]
87	W	- [Without ICC]
88	BG	- [With ICC]
89	LG	- [Without ICC]
90	BR	-
91	GR	-
92	BR	-
93	SB	-
85	Y	-
96	W	-

97	W	-
98	SHIELD	-
100	Y	-

Connector No.	M6
Connector Name	WIRE TO WIRE
Connector Type	TH801MW-CS16-TM4

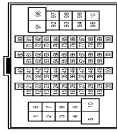

Terminal No.	Color Of Wire	Signal Name [Specification]
1	G	-
2	BG	-
3	LG	- [Without Auto aircon seat]
4	LG	- [With Auto aircon seat]
5	GR	-
6	W	-
7	G	-
8	W	-
9	P	-
10	BR	-
11	B	-
12	G	-
13	R	-
14	W	-
15	SHIELD	-
16	BR	-
17	L	-
18	P	-
19	G	-
20	GR	- [Without ICC]
21	BR	- [With ICC]
22	L	- [Without ICC]
23	R	- [With ICC]
24	G	- [Without ICC]
25	L	- [With ICC]
26	SHIELD	- [Without ICC]
28	LG	-
29	LG	-
30	BG	-
32	W	-
33	Y	-
34	BG	-

26	SHIELD	-
28	GR	-
29	V	-
30	BG	-
32	W	-
33	Y	-
34	L	-
37	G	-
38	R	-
39	G	-
41	L	-
42	W	-
43	R	-
44	LG	-
45	GR	-
46	W	-
47	L	-
48	P	-
48	BG	-
50	LG	-
51	SB	-
52	Y	-
53	BG	-
54	BR	-
55	SB	-
59	SB	-
60	SB	-
61	V	-
62	P	-
63	R	-
64	L	-
65	BG	-
69	V	-
70	SHIELD	-
71	BG	-
72	GR	-
73	W	-
74	SB	-
76	V	-
77	V	-
78	Y	-
80	BG	-
81	L	-
82	W	-
83	Y	-
84	L	-
85	P	-
86	BR	-
87	P	-
88	V	-

SIDE SUPPORT

< DTC/CIRCUIT DIAGNOSIS >

SIDE SUPPORT

89	G	-	-	-	-
90	P	-	-	-	-
91	R	-	-	-	-
92	R	-	-	-	-
93	GR	-	-	-	-
95	G	-	-	-	-
96	W	-	-	-	-
97	W	-	-	-	-
98	SHIELD	-	-	-	-
100	Y	-	-	-	-

Connector No.	M7
Connector Name	WIRE TO WIRE
Connector Type	TH80MW-GS16-TM4



Terminal No.	Color Of Wire	Signal Name [Specification]
1	G	- [With Auto aircon seat]
1	Y	- [Without Auto aircon seat]
2	B	-
3	W	-
6	P	-
7	V	-
8	BG	-
10	W	-
11	BG	-
12	B	-
13	G	-
14	R	-
15	W	-
16	SHIELD	-
17	L	-
18	P	-
19	G	-
20	R	-
21	LG	-
23	V	-
24	B	-
25	BR	-
26	GR	-
27	BG	-

28	W	-	-	-	-
38	B	-	-	-	-
39	B	-	-	-	-
43	SB	-	-	-	-
44	W	-	-	-	-
45	B	-	-	-	-
51	V	-	-	-	-
52	LG	-	-	-	-
53	SHIELD	-	-	-	-
54	BR	-	-	-	-
55	Y	-	-	-	-
56	SHIELD	-	-	-	-
57	P	-	-	-	-
58	L	-	-	-	-
59	SHIELD	-	-	-	-
60	-	-	-	-	-
61	BR	-	-	-	-
62	R	-	-	-	-
63	Y	-	-	-	-
64	L	-	-	-	-
65	W	-	-	-	-
66	V	-	-	-	-
67	LG	-	-	-	-
68	Y	-	-	-	-
69	G	-	-	-	-
70	V	-	-	-	-
71	W	-	-	-	-
72	B	-	-	-	-
73	W	-	-	-	-
74	LG	-	-	-	-
75	P	-	-	-	-
76	LG	-	-	-	-
77	SB	-	-	-	-
78	GR	-	-	-	-
79	R	-	-	-	-
80	L	-	-	-	-
81	P	-	-	-	-
82	L	-	-	-	-
83	P	-	-	-	-
84	SB	-	-	-	-
85	W	-	-	-	-
86	Y	-	-	-	-
87	B	-	-	-	-
88	G	-	-	-	-
89	BG	-	-	-	-
91	R	-	-	-	-
92	BG	-	-	-	-
93	BR	-	-	-	-
94	V	-	-	-	-
96	BG	-	-	-	-

97	W	-	-	-	-
98	R	-	-	-	-
99	BG	-	-	-	-

Connector No.	M62
Connector Name	CIRCUIT BREAKER
Connector Type	M02FW-P4C



Terminal No.	Color Of Wire	Signal Name [Specification]
1	W	-
2	W	-

Connector No.	M151
Connector Name	WIRE TO WIRE
Connector Type	M03FW-LC



Terminal No.	Color Of Wire	Signal Name [Specification]
1	W	-
2	Y	-
3	R	-

Connector No.	M152
Connector Name	WIRE TO WIRE
Connector Type	M03MW-LC



Terminal No.	Color Of Wire	Signal Name [Specification]
1	W	-
2	Y	-
3	R	-

A
B
C
D
E
F
G
H
I
SE
K
L
M
N
O
P

LUMBAR SUPPORT

< DTC/CIRCUIT DIAGNOSIS >

LUMBAR SUPPORT

Wiring Diagram - LUMBAR SUPPORT -

INFOID:000000010584558

PM : With automatic drive positioner
OP : Without automatic drive positioner

LUMBAR SUPPORT

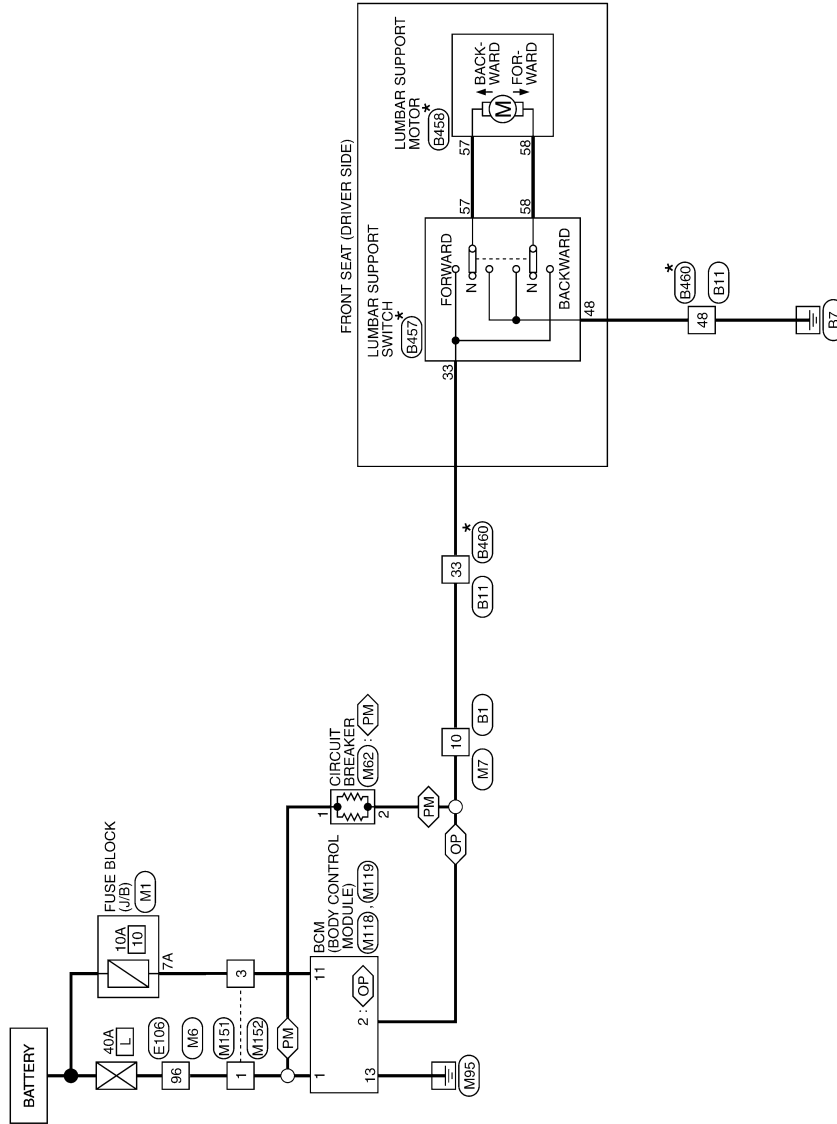

* : This connector is not shown in "Harness Layout".

2014/03/18

JRJWC5573GB

LUMBAR SUPPORT

< DTC/CIRCUIT DIAGNOSIS >

LUMBAR SUPPORT

Connector No.	B1
Connector Name	WIRE TO WIRE
Connector Type	TH80FM-CS16-TM4

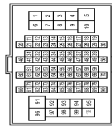

Terminal No.	Color Of Wire	Signal Name [Specification]
1	G	-
2	L	-
3	W	-
4	G	-
5	P	-
6	BG	-
7	SB	-
8	SB	-
9	SB	-
10	B	-
11	G	-
12	R	-
13	W	-
14	W	-
15	W	-
16	SHIELD	-
17	L	-
18	P	-
19	G	-
20	Y	-
21	W	-
23	V	-
24	P	-
25	BR	-
26	GR	-
27	BG	-
28	W	-
38	B	-
39	B	-
43	S5	-
44	V	-
45	GR	-
51	V	-
52	SB	-
53	SHIELD	-
54	BR	-
55	Y	-
56	SHIELD	-

57	P	-
58	L	-
59	SHIELD	-
60	L	-
61	P	-
62	GR	-
63	G	-
64	BG	-
65	W	-
66	V	-
67	LG	-
68	Y	-
69	G	-
70	GR	-
71	G	-
72	B	-
73	W	-
74	V	-
75	P	-
76	LG	-
77	L	-
78	GR	-
79	W	-
80	L	-
81	P	-
82	L	-
83	P	-
84	SB	-
85	R	-
86	Y	-
87	B	-
88	G	-
89	BR	-
91	R	-
92	BG	-
93	BR	-
94	V	-
96	BG	-
97	W	-
98	GR	-
99	W	-

Connector No.	B11
Connector Name	WIRE TO WIRE
Connector Type	NS16FM-CS

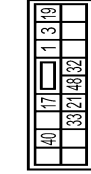

Terminal No.	Color Of Wire	Signal Name [Specification]
1	G	-
3	L	-
17	LG	-
18	P	-
21	Y	-
32	B	-
33	SB	-
40	R	-
48	B	-

Connector No.	B457
Connector Name	LUMBAR SUPPORT SWITCH
Connector Type	NS04FM-CS



Terminal No.	Color Of Wire	Signal Name [Specification]
33	R	-
48	B	-
57	W	-
58	L	-

Connector No.	B458
Connector Name	LUMBAR SUPPORT MOTOR
Connector Type	C02FW



Terminal No.	Color Of Wire	Signal Name [Specification]
57	W	-
58	L	-

Connector No.	B460
Connector Name	WIRE TO WIRE
Connector Type	NS16MW-LC



Terminal No.	Color Of Wire	Signal Name [Specification]
1	L/W	-
3	R/Y	-
17	Y/R	-
19	V	-
21	L/Y	-
32	B/W	-
33	R	-
40	R/W	-
48	B	-

A
B
C
D
E
F
G
H
I
SE
K
L
M
N
O
P

LUMBAR SUPPORT

< DTC/CIRCUIT DIAGNOSIS >

LUMBAR SUPPORT

Connector No.	IE106
Connector Name	WIRE TO WIRE
Connector Type	TH80FM-CST6-TM4

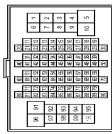

Terminal No.	Color Of Wire	Signal Name [Specification]
1	G	-
2	BG	-
3	LG	-
4	SB	-
5	Y	-
6	W	-
7	G	-
8	V	-
9	R	-
10	BR	-
11	B	-
12	G	-
13	R	-
14	W	-
15	SHIELD	-
16	SB	-
17	L	-
18	P	-
19	G	- [With ICC]
20	W	- [Without ICC]
21	BR	- [With ICC]
22	R	- [Without ICC]
23	G	- [With ICC]
24	L	- [Without ICC]
25	Y	- [With ICC]
26	SHIELD	- [Without ICC]
28	LG	-
29	LG	-
30	BG	-
32	W	-
33	Y	-
34	BG	-

37	Y	-
38	GR	-
39	LG	-
41	LG	-
42	V	-
43	R	-
44	G	-
45	GR	-
46	W	-
47	L	-
48	P	-
49	SB	-
50	BR	-
51	B	-
52	Y	-
53	BG	-
54	R	-
55	SB	-
58	P	-
60	SB	-
61	V	-
62	P	-
63	LG	-
64	L	-
65	BG	-
69	L	-
70	SHIELD	-
71	G	-
72	G	-
73	R	-
74	BR	-
76	L	-
77	W	-
78	Y	-
80	SB	-
81	L	-
82	W	-
83	LG	-
84	GR	-
85	G	-
86	P	-
87	W	-
88	BG	-
89	LG	-
90	BR	-
91	GR	-
92	BR	-
93	SB	-
95	Y	-
96	W	-

97	W	-
98	SHIELD	-
100	Y	-

Connector No.	M1
Connector Name	FUSE BLOCK (JB)
Connector Type	NS08FM-M2

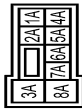

Terminal No.	Color Of Wire	Signal Name [Specification]
1A	BG	-
2A	G	-
3A	L	-
4A	R	-
5A	V	-
6A	Y	-
7A	R	-
8A	L	-

Connector No.	M6
Connector Name	WIRE TO WIRE
Connector Type	TH80MV-CST6-TM4



Terminal No.	Color Of Wire	Signal Name [Specification]
1	G	-
2	BG	-
3	LG	- [Without Auto aircon seat]
4	SB	- [With Auto aircon seat]
5	LG	-
6	GR	-
6	W	-

7	G	-
8	W	-
9	P	-
10	BR	-
11	B	-
12	G	-
13	R	-
14	W	-
15	SHIELD	-
16	BR	-
17	L	-
18	P	-
19	G	-
20	GR	- [Without ICC]
20	W	- [With ICC]
21	BR	- [With ICC]
21	R	- [Without ICC]
22	L	- [Without ICC]
22	R	- [With ICC]
23	G	-
24	L	-
24	P	- [With ICC]
25	W	- [Without ICC]
25	Y	- [With ICC]
26	SHIELD	-
28	GR	-
29	V	-
30	BG	-
32	W	-
33	Y	-
34	L	-
37	G	-
38	R	-
39	G	-
41	L	-
42	W	-
43	R	-
44	LG	-
45	GR	-
46	W	-
47	L	-
48	P	-
49	BG	-
50	LG	-
51	SB	-
52	Y	-
53	BG	-
54	BR	-
55	SB	-
56	SB	-
59	SB	-

LUMBAR SUPPORT

< DTC/CIRCUIT DIAGNOSIS >

LUMBAR SUPPORT

60	SB	-	-	-	-
61	V	-	-	-	-
62	P	-	-	-	-
63	R	-	-	-	-
64	L	-	-	-	-
65	BG	-	-	-	-
69	V	-	-	-	-
70	SHIELD	-	-	-	-
71	BG	-	-	-	-
72	GR	-	-	-	-
73	W	-	-	-	-
74	SB	-	-	-	-
76	V	-	-	-	-
77	V	-	-	-	-
78	Y	-	-	-	-
80	BG	-	-	-	-
81	W	-	-	-	-
82	W	-	-	-	-
83	Y	-	-	-	-
84	L	-	-	-	-
85	P	-	-	-	-
86	BR	-	-	-	-
87	P	-	-	-	-
88	V	-	-	-	-
89	G	-	-	-	-
90	P	-	-	-	-
91	R	-	-	-	-
92	R	-	-	-	-
93	GR	-	-	-	-
95	G	-	-	-	-
96	W	-	-	-	-
97	W	-	-	-	-
98	SHIELD	-	-	-	-
100	Y	-	-	-	-

Connector No.	M7
Connector Name	WIPE TO WIRE
Connector Type	TH80MW-CS16-TM4



Terminal No.	Color Of Wire	Signal Name [Specification]
1	G	- [With Auto aircon seat]
1	Y	- [With Auto aircon seat]
2	B	-
3	W	-
6	P	-
7	V	-
8	BG	-
10	W	-
11	BG	-
12	B	-
13	G	-
14	R	-
15	W	-
16	SHIELD	-
17	L	-
18	P	-
19	G	-
20	R	-
21	LG	-
23	V	-
24	P	-
25	BR	-
26	GR	-
27	BG	-
28	W	-
38	B	-
39	B	-
43	SB	-
44	W	-
45	B	-
51	V	-
52	LG	-
53	SHIELD	-
54	GR	-
55	Y	-
56	SHIELD	-

57	P	-	-	-	-
58	L	-	-	-	-
59	SHIELD	-	-	-	-
60	L	-	-	-	-
61	BR	-	-	-	-
62	R	-	-	-	-
63	Y	-	-	-	-
64	L	-	-	-	-
65	W	-	-	-	-
66	V	-	-	-	-
67	LG	-	-	-	-
68	Y	-	-	-	-
69	G	-	-	-	-
70	V	-	-	-	-
71	W	-	-	-	-
72	B	-	-	-	-
73	W	-	-	-	-
74	LG	-	-	-	-
75	P	-	-	-	-
76	LG	-	-	-	-
77	SB	-	-	-	-
78	GR	-	-	-	-
79	R	-	-	-	-
80	L	-	-	-	-
81	P	-	-	-	-
82	L	-	-	-	-
83	P	-	-	-	-
84	SB	-	-	-	-
85	W	-	-	-	-
86	Y	-	-	-	-
87	B	-	-	-	-
88	G	-	-	-	-
89	BG	-	-	-	-
91	R	-	-	-	-
92	BG	-	-	-	-
93	BR	-	-	-	-
94	V	-	-	-	-
96	BG	-	-	-	-
97	W	-	-	-	-
98	R	-	-	-	-
99	BG	-	-	-	-

Connector No.	M62
Connector Name	CIRCUIT BREAKER
Connector Type	M02FM-PLC



Terminal No.	Color Of Wire	Signal Name [Specification]
1	W	-
2	W	-

Connector No.	M118
Connector Name	BCM (BODY CONTROL MODULE)
Connector Type	M03FB-LC



Terminal No.	Color Of Wire	Signal Name [Specification]
1	W	BAT (F/L)
2	Y	POWER WINDOW POWER SUPPLY (BAT)
3	BG	POWER WINDOW POWER SUPPLY (RAP)

A
B
C
D
E
F
G
H
I
SE
K
L
M
N
O
P

LUMBAR SUPPORT

< DTC/CIRCUIT DIAGNOSIS >

LUMBAR SUPPORT

Connector No.	M119
Connector Name	BCM (BODY CONTROL MODULE)
Connector Type	NS16FW-CS



4	5	7	8	9	10
11	13	15	17	18	19

Terminal No.	Wire	Signal Name [Specification]
4	P	INT ROOM LAMP PWR SUPPLY (BAT SAME)
5	V	PASSENGER DOOR UNLOCK OUTPUT
7	Y	STEER LAMP OUTPUT
8	V	ALL DOOR FUEL LID LOCK OUTPUT
9	G	DRIVER DOOR FUEL LID UNLOCK OUTPUT
10	BR	REAR DOOR UNLOCK OUTPUT
11	R	BAT (RUSE)
13	B	GROUND
15	Y	ACC IND
17	W	TURN SIGNAL RH (FRONT)
18	BG	TURN SIGNAL LH (FRONT)
19	SB	ROOM LAMP TIMER



1	3	2
---	---	---

Connector No.	M151
Connector Name	WIRE TO WIRE
Connector Type	M03FW-LC

Terminal No.	Wire	Signal Name [Specification]
1	W	-
2	Y	-
3	R	-

Connector No.	M152
Connector Name	WIRE TO WIRE
Connector Type	M03MW-LC



1	2	3
---	---	---

Terminal No.	Wire	Signal Name [Specification]
1	W	-
2	Y	-
3	R	-

CLIMATE CONTROLLED SEAT CONTROL UNIT

< ECU DIAGNOSIS INFORMATION >

ECU DIAGNOSIS INFORMATION

CLIMATE CONTROLLED SEAT CONTROL UNIT

Reference Value

INFOID:000000010584559

TERMINAL LAYOUT

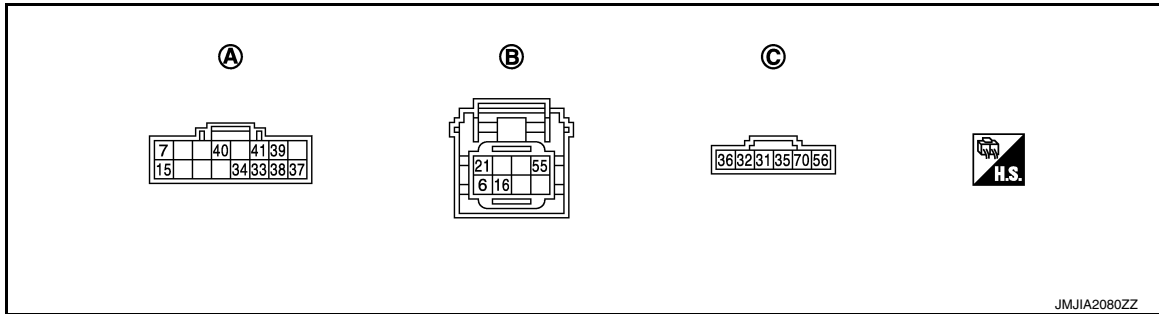

A. B507 (driver side)
B517 (passenger side)

B. B508 (driver side)
B518 (passenger side)

C. B509 (driver side)
B519 (passenger side)

PHYSICAL VALUES

Terminal No.		Wire color	Description		Condition	Value (Approx.)	
+	-		Signal name	Input/Output			
6	Ground	R	COOL switch signal	Input	Climate controlled seat switch	HI COOL	2.6 - 4.2
						MID COOL	1.6 - 2.5
						LO COOL	0.8 - 1.5
						OFF	0
7	Ground	L	HEAT switch indicator signal	Output	Climate controlled seat switch	HEAT	Battery voltage
						OFF	0
15	Ground	W	COOL switch indicator signal	Output	Climate controlled seat switch	COOL	Battery voltage
						OFF	0
16	Ground	G	HEAT switch signal	Input	Climate controlled seat switch	HI HEAT	2.6 - 4.2
						MID HEAT	1.6 - 2.5
						LO HEAT	0.8 - 1.5
						OFF	0
21	Ground	P	Climate controlled seat switch power supply	Output	Ignition switch ON	Battery voltage	
31	Ground	L/R	Seat cushion thermal electric device HEAT signal	Input	Climate controlled seat switch	HEAT or COOL	0 - Battery voltage*
						OFF	0
32	Ground	G/R	Seat cushion thermal electric device COOL signal	Input	Climate controlled seat switch	HEAT or COOL	0 - Battery voltage*
						OFF	0
33	Ground	B/R	Seat cushion thermal electric device sensor signal	Input	Climate controlled seat operated	1 - 5	
34	Ground	Y/R	Seat cushion thermal electric device sensor ground	—	Ignition switch ON	0	

CLIMATE CONTROLLED SEAT CONTROL UNIT

< ECU DIAGNOSIS INFORMATION >

Terminal No.		Wire color	Description		Condition		Value (Approx.)
+	-		Signal name	Input/ Output			
35	Ground	V	Seatback thermal electric device HEAT signal	Input	Climate controlled seat switch	HEAT or COOL	0 - Battery voltage*
						OFF	0
36	Ground	O	Seatback thermal electric device COOL signal	Input	Climate controlled seat switch	HEAT or COOL	0 - Battery voltage*
						OFF	0
37	Ground	SB	Seatback thermal electric device sensor signal	Input	Climate controlled seat operated		1 - 5
38	Ground	B	Seatback thermal electric device sensor ground	—	Ignition switch ON		0
39	Ground	G/W	Blower motor power supply	Output	Climate controlled seat switch	HEAT or COOL	Battery voltage
					Other than the above		0
40	Ground	R/W	Blower motor speed control signal	Input	Climate controlled seat switch	HEAT	8.5 - 9
						HI COOL	12
						MID COOL	9
						LO COOL	8
41	Ground	B/W	Blower motor ground	—	—		0
55	Ground	W	Ignition switch power supply	Input	Ignition switch ON		Battery voltage
56	Ground	B	Ground	—	—		0
70	Ground	R	Ignition switch power supply	Input	Ignition switch ON		Battery voltage

*:It changes between battery voltage or 0V

NOTE:

- Measure the value on the condition that the battery voltage is 14 V
- Wait 1 minute or more after terminal electric device is activated, and then start the measurement

CLIMATE CONTROLLED SEAT CONTROL UNIT

< ECU DIAGNOSIS INFORMATION >

Wiring Diagram - CLIMATE CONTROLLED SEAT CONTROL SYSTEM -

INFOID:0000000110584560

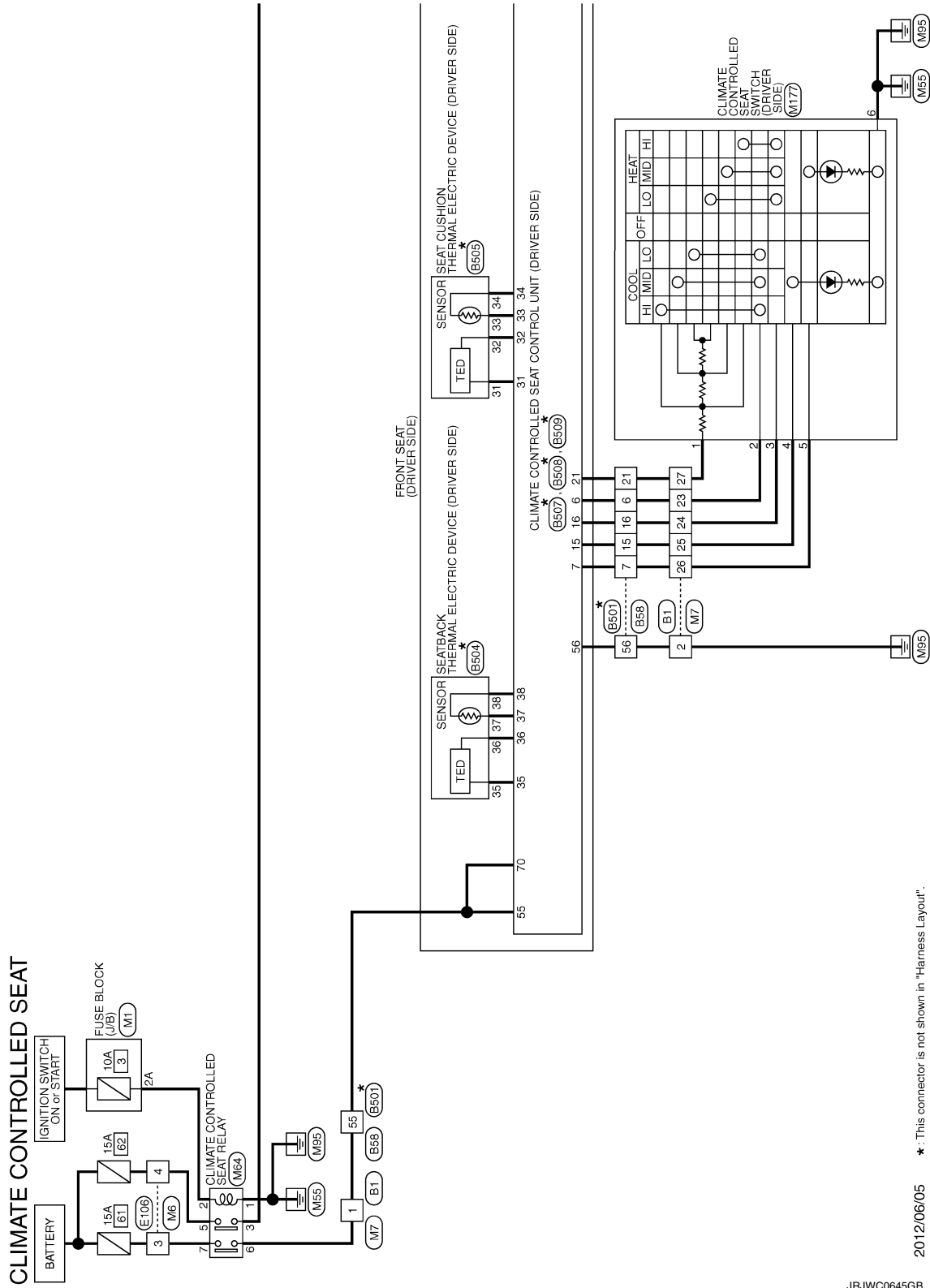

2012/06/05 * This connector is not shown in "Harness Layout".

JRJWC0645GB

A
B
C
D
E
F
G
H
I
SE
K
L
M
N
O
P

CLIMATE CONTROLLED SEAT CONTROL UNIT

< ECU DIAGNOSIS INFORMATION >

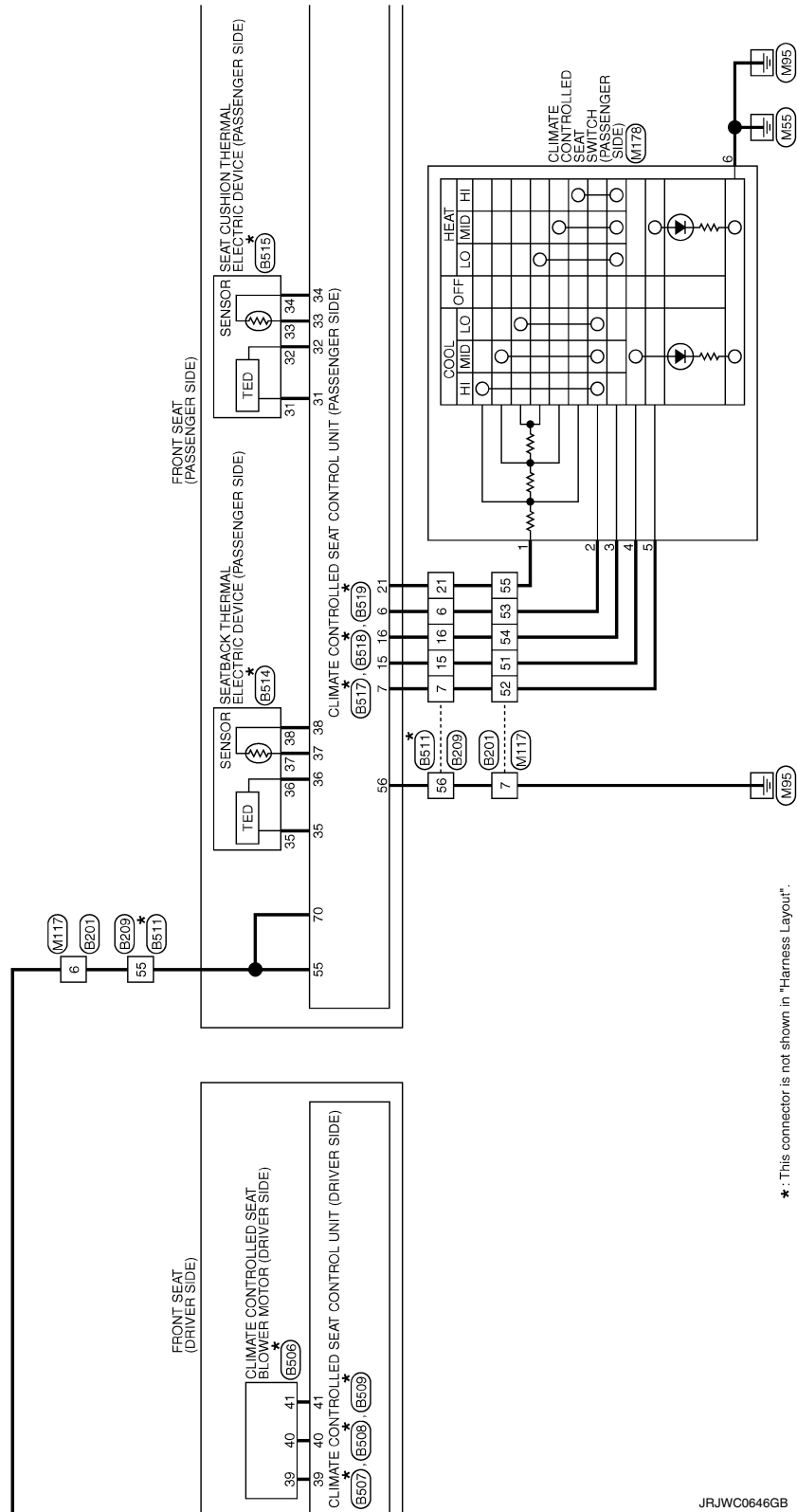

*: This connector is not shown in "Harness Layout".

JRJJWC0646GB

CLIMATE CONTROLLED SEAT CONTROL UNIT

< ECU DIAGNOSIS INFORMATION >

A
B
C
D
E
F
G
H
I
SE
K
L
M
N
O
P

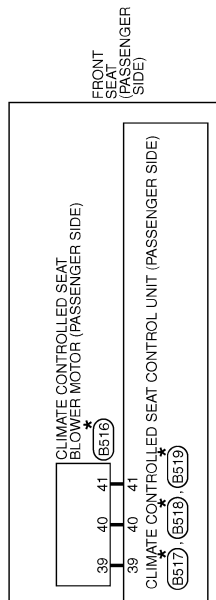

*: This connector is not shown in "Harness Layout".

JRJWC0647GB

CLIMATE CONTROLLED SEAT CONTROL UNIT

< ECU DIAGNOSIS INFORMATION >

CLIMATE CONTROLLED SEAT

Connector No.	B1
Connector Name	WIRE TO WIRE
Connector Type	TH80FW-CS16-TM4

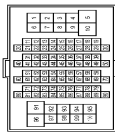

Terminal No.	Color Of Wire	Signal Name [Specification]
1	G	-
2	L	-
3	W	-
4	G	-
5	P	-
6	BG	-
7	SB	-
8	BG	-
9	SB	-
10	SB	-
11	SB	-
12	B	-
13	G	-
14	R	-
15	W	-
16	SHIELD	-
17	L	-
18	P	-
19	G	-
20	Y	-
21	W	-
22	V	-
23	V	-
24	P	-
25	BR	-
26	GR	-
27	BG	-
28	W	-
29	B	-
30	B	-
31	SB	-
32	V	-
33	GR	-
34	SB	-
35	SHIELD	-
36	SHIELD	-

Connector No.	B58
Connector Name	WIRE TO WIRE
Connector Type	NS10FW-CS

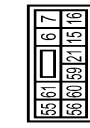

Terminal No.	Color Of Wire	Signal Name [Specification]
6	V	-
7	GR	-
15	BR	-
16	P	-
21	BG	-
55	G	-
56	L	-
59	LG	-
60	B	-
61	SB	-

Connector No.	B201
Connector Name	WIRE TO WIRE
Connector Type	TH80FW-CS16-TM4

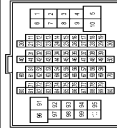

Terminal No.	Color Of Wire	Signal Name [Specification]
1	G	-
2	R	-
3	BR	-
4	SB	-
6	BG	-
7	GR	-
8	W	-
10	C	-
11	SHIELD	-

20	L	-
21	P	-
22	GR	-
23	LG	-
24	W	-
25	V	-
26	G	-
27	Y	-
28	SHIELD	-
31	W	-
32	GR	-
33	SB	-
36	L	-
37	P	-
38	L	-
39	P	-
40	LG	- [With ICC]
41	V	- [With ICC]
41	SB	- [With ICC]
41	Y	- [Without ICC]
42	V	- [With ICC]
42	W	- [Without ICC]
43	B	- [Without ICC]
43	BR	- [With ICC]
44	R	-
44	R	-
45	G	-
46	BG	- [With ICC]
46	SHIELD	- [Without ICC]
47	B	- [Without ICC]
47	L	- [With ICC]
48	P	- [With ICC]
48	R	- [Without ICC]
49	G	- [With ICC]
49	W	- [Without ICC]
50	SHIELD	-
51	W	-
52	R	-
53	G	-
54	L	-
55	SB	-
60	GR	-
61	LG	-
62	SB	-
63	P	-
64	BR	-
65	BG	-
66	Y	-
67	W	-
69	G	-

CLIMATE CONTROLLED SEAT CONTROL UNIT

< ECU DIAGNOSIS INFORMATION >

CLIMATE CONTROLLED SEAT

71	SB	-
72	V	-
73	LG	-
74	W	-
75	BR	-
76	V	-
77	LG	-
80	BG	-
82	P	-
83	Y	-
84	R	-
85	SB	-
86	GR	-
87	L	-
91	V	-
92	W	-
93	R	-
94	LG	-
95	GR	-
96	W	-
97	G	-
98	BG	-
99	L	-

Connector No.	B209
Connector Name	WIRE TO WIRE
Connector Type	NS10FW-CS

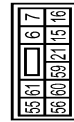

Terminal No.	Color Of Wire	Signal Name [Specification]
6	G	-
7	R	-
15	W	-
16	L	-
21	SB	-
55	BG	-
56	GR	-
59	V	-
60	B	-
61	LG	-

Connector No.	B501
Connector Name	WIRE TO WIRE
Connector Type	NS10MW-CS

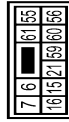

Terminal No.	Color Of Wire	Signal Name [Specification]
6	R	-
7	L	-
15	W	-
16	G	-
21	P	-
55	W	-
56	B	-
59	L/Y	-
60	R/Y	-
61	B/Y	-

Connector No.	B504
Connector Name	SEATBACK THERMAL ELECTRIC DEVICE (DRIVER SIDE)
Connector Type	6098-2163



Terminal No.	Color Of Wire	Signal Name [Specification]
35	V	-
36	O	-
37	SB	-
38	B	-

Connector No.	B505
Connector Name	SEAT CUSHION THERMAL ELECTRIC DEVICE (DRIVER SIDE)
Connector Type	6098-2163



Terminal No.	Color Of Wire	Signal Name [Specification]
31	L/R	-
32	G/R	-
33	B/R	-
34	Y/R	-

Connector No.	B506
Connector Name	CLIMATE CONTROLLED SEAT FLOWER MOTOR DRIVER SEAT
Connector Type	7285-5830

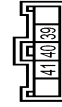

Terminal No.	Color Of Wire	Signal Name [Specification]
39	G/W	-
40	R/W	-
41	B/W	-

Connector No.	B507
Connector Name	CLIMATE CONTROLLED SEAT CONTROL UNIT (DRIVER SIDE)
Connector Type	1539_4150



Terminal No.	Color Of Wire	Signal Name [Specification]
7	L	-
15	W	-
32	B/R	-
34	Y/R	-
37	SB	-
38	B	-
39	G/W	-
40	R/W	-
41	B/W	-

Connector No.	B508
Connector Name	CLIMATE CONTROLLED SEAT CONTROL UNIT (DRIVER SIDE)
Connector Type	1540_6141

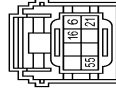

Terminal No.	Color Of Wire	Signal Name [Specification]
6	R	-
16	G	-
21	P	-
55	W	-

A
B
C
D
E
F
G
H
I
SE
K
L
M
N
O
P

CLIMATE CONTROLLED SEAT CONTROL UNIT

< ECU DIAGNOSIS INFORMATION >

CLIMATE CONTROLLED SEAT

Connector No.	B509
Connector Name	CLIMATE CONTROLLED SEAT CONTROL UNIT (DRIVER SIDE)
Connector Type	1533_2141



Terminal No.	Color Of Wire	Signal Name (Specification)
31	L/R	-
32	G/R	-
35	V	-
36	O	-
56	B	-
70	R	-

Connector No.	B511
Connector Name	WIRE TO WIRE
Connector Type	NS10MW-CS

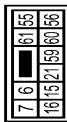

Terminal No.	Color Of Wire	Signal Name (Specification)
6	R	-
7	L	-
15	W	-
16	G	-
21	P	-
55	W	-
56	B	-
59	L/Y	-
60	R/Y	-
61	B/Y	-

Connector No.	B514
Connector Name	SEATBACK THERMAL ELECTRIC DEVICE (PASSENGER SIDE)
Connector Type	6096-2163



Terminal No.	Color Of Wire	Signal Name (Specification)
35	V	-
36	O	-
37	SB	-
38	B	-

Connector No.	B515
Connector Name	SEAT CUSHION THERMAL ELECTRIC DEVICE (PASSENGER SIDE)
Connector Type	6096-2163



Terminal No.	Color Of Wire	Signal Name (Specification)
31	L/R	-
32	G/R	-
33	B/R	-
34	Y/R	-

Connector No.	B516
Connector Name	CLIMATE CONTROLLED SEAT BLOWER MOTOR (PASSENGER SIDE)
Connector Type	7293-5630



Terminal No.	Color Of Wire	Signal Name (Specification)
39	GW	-
40	RAW	-
41	B/W	-

Connector No.	B517
Connector Name	CLIMATE CONTROLLED SEAT CONTROL UNIT (PASSENGER SIDE)
Connector Type	1539_4150

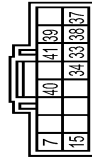

Terminal No.	Color Of Wire	Signal Name (Specification)
7	L	-
15	W	-
33	B/R	-
34	Y/R	-
37	SB	-
38	B	-
39	GW	-
40	RAW	-
41	B/W	-

Connector No.	B518
Connector Name	CLIMATE CONTROLLED SEAT CONTROL UNIT (PASSENGER SIDE)
Connector Type	1540_6141

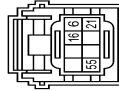

Terminal No.	Color Of Wire	Signal Name (Specification)
6	R	-
16	G	-
21	P	-
55	W	-

Connector No.	B519
Connector Name	CLIMATE CONTROLLED SEAT CONTROL UNIT (PASSENGER SIDE)
Connector Type	1533_2141



Terminal No.	Color Of Wire	Signal Name (Specification)
31	L/R	-
32	G/R	-
35	V	-
36	O	-
56	B	-
70	R	-

CLIMATE CONTROLLED SEAT CONTROL UNIT

< ECU DIAGNOSIS INFORMATION >

CLIMATE CONTROLLED SEAT

Connector No.	IE106
Connector Name	WIRE TO WIRE
Connector Type	TH80FM-CS16-TM4

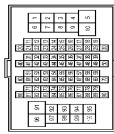

Terminal No.	Color Of Wire	Signal Name [Specification]
1	G	-
2	BG	-
3	SB	-
4	LG	-
5	Y	-
6	W	-
7	G	-
8	V	-
9	R	-
10	BR	-
11	B	-
12	G	-
13	R	-
14	W	-
15	SHIELD	-
16	SB	-
17	L	-
18	P	-
19	G	-
20	W	- [With ICC]
21	BR	- [Without ICC]
22	V	- [With ICC]
23	G	- [Without ICC]
24	L	- [With ICC]
25	L	- [Without ICC]
26	SHIELD	- [With ICC]
28	G	-
29	LG	-
30	BG	-
32	W	-
34	BG	-
37	L	-
38	R	-
39	G	-
41	L	-
42	W	-
43	R	-
44	LG	-
45	GR	-
46	W	-
47	L	-
48	P	-
49	BG	-
50	LG	-
51	SB	-
52	Y	-
53	BG	-
54	BR	-
55	SB	-
56	P	-
57	G	-
58	V	-
59	R	-
60	BR	-
61	V	-
62	P	-
63	LG	-
64	L	-
65	BG	-
66	L	-
69	L	-
70	SHIELD	-
71	G	-
72	G	-
73	R	-
74	BR	-
76	L	-
77	W	-
78	Y	-
80	SB	-
81	L	-
82	W	-
83	LG	-
84	GR	-
85	G	-
86	P	-
87	W	-
88	BG	-
89	LG	-
90	BR	-
91	GR	-
92	BR	-
93	SB	-
95	Y	-
96	W	-

97	W	-
98	SHIELD	-
100	Y	-

Connector No.	M1
Connector Name	FUSE BLOCK (JIB)
Connector Type	NS06FM-M2

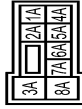

Terminal No.	Color Of Wire	Signal Name [Specification]
1A	BG	-
2A	G	-
3A	L	-
4A	R	-
5A	V	-
6A	Y	-
7A	R	-
8A	L	-

Connector No.	M6
Connector Name	WIRE TO WIRE
Connector Type	TH80MW-CS16-TM4

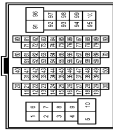

Terminal No.	Color Of Wire	Signal Name [Specification]
1	G	-
2	BG	-
3	LG	- [Without Auto aircon seat]
3	SB	- [With Auto aircon seat]
4	LG	-
5	GR	-
6	W	-

7	G	-
8	W	-
9	P	-
10	BR	-
11	B	-
12	G	-
13	R	-
14	W	-
15	SHIELD	-
16	BR	-
17	L	-
18	P	-
19	G	-
20	GR	- [Without ICC]
20	W	- [With ICC]
21	BR	- [Without ICC]
21	R	- [With ICC]
22	L	-
23	R	-
24	L	-
24	L	- [With ICC]
24	P	- [Without ICC]
25	W	-
25	Y	- [With ICC]
26	SHIELD	-
28	GR	-
29	V	-
30	BG	-
32	W	-
33	Y	-
34	L	-
37	G	-
38	R	-
39	G	-
41	L	-
42	W	-
43	R	-
44	LG	-
45	GR	-
46	W	-
47	L	-
48	P	-
49	BG	-
50	LG	-
51	SB	-
52	Y	-
53	BG	-
54	BR	-
55	SB	-
59	SB	-

A
B
C
D
E
F
G
H
I
SE
K
L
M
N
O
P

CLIMATE CONTROLLED SEAT CONTROL UNIT

< ECU DIAGNOSIS INFORMATION >

CLIMATE CONTROLLED SEAT

60	SB	-
61	V	-
62	P	-
63	R	-
64	L	-
65	BG	-
69	V	-
70	SHIELD	-
71	BG	-
72	GR	-
73	W	-
74	SB	-
76	V	-
77	V	-
78	Y	-
80	BG	-
81	L	-
82	W	-
83	Y	-
84	L	-
85	P	-
86	BR	-
87	P	-
88	V	-
89	G	-
90	P	-
91	R	-
92	R	-
93	GR	-
95	G	-
96	W	-
97	W	-
98	SHIELD	-
100	Y	-

Connector No.	M7
Connector Name	WIRE TO WIRE
Connector Type	TH80MW-CS16-TM4

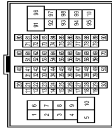

Terminal No.	Color Of Wire	Signal Name [Specification]
1	G	- [With Auto aircon seat]
1	Y	- [Without Auto aircon seat]
2	B	-
3	W	-
6	P	-
7	V	-
8	LG	-
8	BG	-
10	W	-
11	BG	-
12	B	-
13	G	-
14	R	-
15	W	-
16	SHIELD	-
17	L	-
18	P	-
19	G	-
20	R	-
21	LG	-
23	V	-
24	P	-
25	BR	-
26	GR	-
27	BG	-
28	W	-
38	B	-
39	B	-
43	SB	-
44	W	-
45	B	-
51	V	-
52	LG	-
53	SHIELD	-
54	BR	-
55	V	-
56	SHIELD	-

57	P	-
58	L	-
59	SHIELD	-
60	L	-
61	BR	-
62	R	-
63	Y	-
64	L	-
65	W	-
66	V	-
67	LG	-
68	Y	-
69	G	-
70	V	-
71	W	-
72	B	-
73	W	-
74	LG	-
75	P	-
76	LG	-
77	SB	-
78	GR	-
79	R	-
80	L	-
81	P	-
82	L	-
83	P	-
84	SB	-
85	W	-
86	Y	-
87	B	-
88	G	-
89	BG	-
91	R	-
92	BG	-
93	BR	-
94	V	-
96	BG	-
97	W	-
98	R	-
99	BG	-

Connector No.	M64
Connector Name	CLIMATE CONTROLLED SEAT RELAY
Connector Type	M06FBR-R-LC

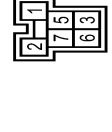

Terminal No.	Color Of Wire	Signal Name [Specification]
1	B	-
2	Y	-
3	Y	-
6	LG	-
6	G	-
7	SB	-

Connector No.	M117
Connector Name	WIRE TO WIRE
Connector Type	TH80MW-CS16-TM4

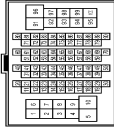

Terminal No.	Color Of Wire	Signal Name [Specification]
1	GR	-
2	BR	-
3	V	-
4	SB	-
6	Y	-
7	B	-
8	W	-
10	W	-
11	SHIELD	-
20	R	-
21	G	-
22	GR	-
23	V	-
24	W	-

CLIMATE CONTROLLED SEAT CONTROL UNIT

< ECU DIAGNOSIS INFORMATION >

A
B
C
D
E
F
G
H
I
SE
K
L
M
N
O
P

CLIMATE CONTROLLED SEAT		
25	R	-
26	P	-
27	L	-
28	SHIELD	-
31	W	-
32	W	-
33	SB	-
36	L	-
37	P	-
38	L	-
39	P	-
40	V	-
41	SB	- [With ICC]
42	V	- [Without ICC]
43	W	- [With ICC]
44	W	- [Without ICC]
45	B	- [With ICC]
46	P	- [Without ICC]
47	R	- [With ICC]
48	G	- [Without ICC]
49	W	- [With ICC]
50	SHIELD	- [Without ICC]
51	BG	-
52	GR	-
53	G	-
54	L	-
55	P	-
60	LG	-
61	R	-
62	SB	-
63	V	-
64	Y	-
65	BR	-
66	BG	-
67	W	-
69	G	-
71	SB	-
72	V	-
73	V	-
74	LG	-
75	BR	-
76	V	-

Connector No.	M178
Connector Name	CLIMATE CONTROLLED SEAT SWITCH (PASSENGER SEAT)
Connector Type	TK08FBR

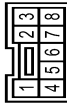

Terminal No.	Color Of Wire	Signal Name [Specification]
1	P	-
2	G	-
3	L	-
4	BG	-
5	GR	-
6	B	-
7	R	-
8	R	-

77	LG	-
80	R	-
82	Y	-
83	BG	-
84	W	-
85	SB	-
86	B	-
87	P	-
91	L	-
92	L	-
93	G	-
94	BG	-
95	V	-
96	G	-
97	G	-
98	L	-
99	LG	-

Connector No.	M177
Connector Name	CLIMATE CONTROLLED SEAT SWITCH (DRIVER SEAT)
Connector Type	TK10FW

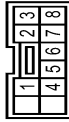

Terminal No.	Color Of Wire	Signal Name [Specification]
1	BG	-
2	V	-
3	P	-
4	BR	-
5	GR	-
6	B	-
7	R	-
8	R	-

Fail-safe

- Climate controlled seat control unit equips fail-safe function.
- When a malfunction occurs in the systems shown as per the following, climate controlled seat control unit stops output.

JRJJWC5589GB

INFOID:000000010584561

CLIMATE CONTROLLED SEAT CONTROL UNIT

< ECU DIAGNOSIS INFORMATION >

Malfunction	Malfunctioning condition
The temperature difference between the seatback thermal electric device and seat cushion thermal electric device is 30°C or more	<ul style="list-style-type: none"> • When it detects for 4 seconds that the temperature difference between the seatback thermal electric device and seat cushion thermal electric device is 30°C or more, stops the output to the thermal electric device, activates the climate controlled seat blower motor in the maximum position, and sends the external airflow for 30 seconds • If the temperature difference is still 30°C or more after 30 seconds pass, it stops all output and enters the system OFF condition • When the temperature difference between seatback thermal electric device and seat cushion thermal electric device becomes 20°C or less, the system recovers automatically • If it detects that the temperature difference is 30°C or more after the automatic system recovery, it immediately stops all output and enters the system OFF condition <p>NOTE: When the switch operation is performed before entering the system OFF condition, the fail-safe mode is reset.</p>
The temperature of thermal electric device is 110°C or more in the HEAT mode (any thermal electric device in the seatback or seat cushion)	<ul style="list-style-type: none"> • When it detects for 4 seconds that the temperature of the thermal electric device is 110°C or more, stops the output to the thermal electric device, activates climate the controlled seat blower motor in the maximum position, and sends the external airflow for 30 seconds • If the temperature does not become 105°C or less after 30 seconds pass, it stops all output and enters the system OFF condition • When the temperature of the thermal electric device becomes 105°C or less, the system recovers automatically • If it detects that the temperature of the thermal electric device is 110°C or more after the automatic system recovery, it immediately stops all output and enters the system OFF condition
The temperature of the thermal electric device is 45°C or more in the COOL mode (any thermal electric device in the seatback or seat cushion)	<ul style="list-style-type: none"> • When it detects for 4 seconds that the temperature of the thermal electric device is between 45°C and 70°C, it starts the temperature monitoring of the thermal electric device at 3 second intervals • While monitoring, if it detects that the temperature raises 2°C or more 4 times continuously or reaches 70°C or more, it stops all output and enters the system OFF condition • If it detects other results of monitoring, it continues activating in the COOL mode
Thermal electric device sensor system open circuit	<ul style="list-style-type: none"> • When it detects for 4 seconds that the thermal electric device sensor system is an open circuit
Climate controlled seat blower motor system open circuit	<ul style="list-style-type: none"> • When it detects for 2 seconds that climate controlled seat blower motor system is an open circuit while the climate controlled seat is being activated, it stops output to the thermal electric device • When it detects for 10 seconds that the climate controlled seat blower motor system is an open circuit while the climate controlled seat is being activated, it stops all output and enters the system OFF condition <p>NOTE: After detecting the climate seat blower motor system open circuit for 2 seconds, the system recovers automatically if the activation of the climate controlled seat blower motor is detected for 1 second or more.</p>
Switch input out of the specified range	<ul style="list-style-type: none"> • When it detects for 4 seconds that the rotary switch input is 30% or less of the vehicle battery voltage, it stops all output and enters the system OFF condition • When the switch input returns to a value within the specified range, the system recovers automatically
HEAT or COOL switch input out of the specified range	<ul style="list-style-type: none"> • When it detects for 4 seconds that rotary switch input is 6% or less of the vehicle battery voltage, it stops all output and enters the system OFF condition • When the switch input returns to a value within the specified range, the system recovers automatically
System voltage out of range	<ul style="list-style-type: none"> • System voltage* of the climate controlled seat control unit is out of the operation range (8.5 V – 16.5 V)

*: System voltage is the voltage between ventilation seat control unit power source and the ground.

NOTE:

CLIMATE CONTROLLED SEAT CONTROL UNIT

< ECU DIAGNOSIS INFORMATION >

When the system enters in the fail-safe mode again after performing resetting procedure, perform diagnosis.

A

B

C

D

E

F

G

H

I

SE

K

L

M

N

O

P

HEATED SEAT CONTROL UNIT

< ECU DIAGNOSIS INFORMATION >

HEATED SEAT CONTROL UNIT

Reference Value

INFOID:000000010584562

TERMINAL LAYOUT

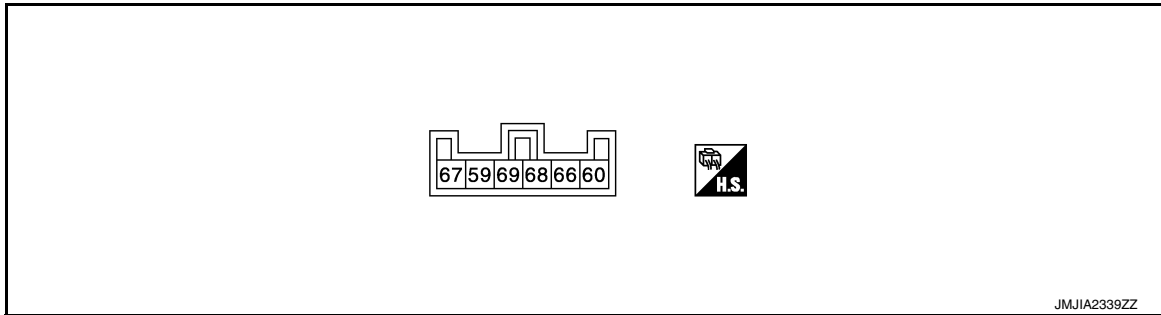

PHYSICAL VALUES

Terminal No. (Wire color)		Description		Condition		Voltage (V) (Approx.)
(+)	(-)	Signal name	Input/ Output			
59 (Y)	Ground	Ground	-	-	-	0
60 (Y/R)	Ground	IGN power supply	Input	Ignition switch	OFF or ACC	0
					ON	Battery voltage
66 (B)	Ground	Heated seat operation signal	Input	Heated seat	Operate	Battery voltage
					Other than the above	0
67 (L)	Ground	Heated seat switch signal	Input	Heated seat switch	OFF	0
					1 (Min. temperature)	12.24
					2	12.33
					3	12.49
					4	12.63
					5	12.76
68 (R/W)	Ground	Seat cushion heater power supply	Output	Heated seat	Operate	0 – Battery voltage*
					Other than the above	0
69 (R)	Ground	Heat sensor signal	Input	Heated seat switch	OFF	0
					1 (Min. temperature)	10.87 – 11.02*
					2	10.93 – 11.07*
					3	11.04 – 11.17*
					4	11.13 – 11.26*
					5	11.22 – 11.34*
6 (Max. temperature)	11.31 – 11.43*					

*: Voltage is repeated within the value shown as per the following list depending on heater unit temperature.

HEATED SEAT CONTROL UNIT

< ECU DIAGNOSIS INFORMATION >

Wiring Diagram - HEATED SEAT SYSTEM -

INFOID:000000010584563

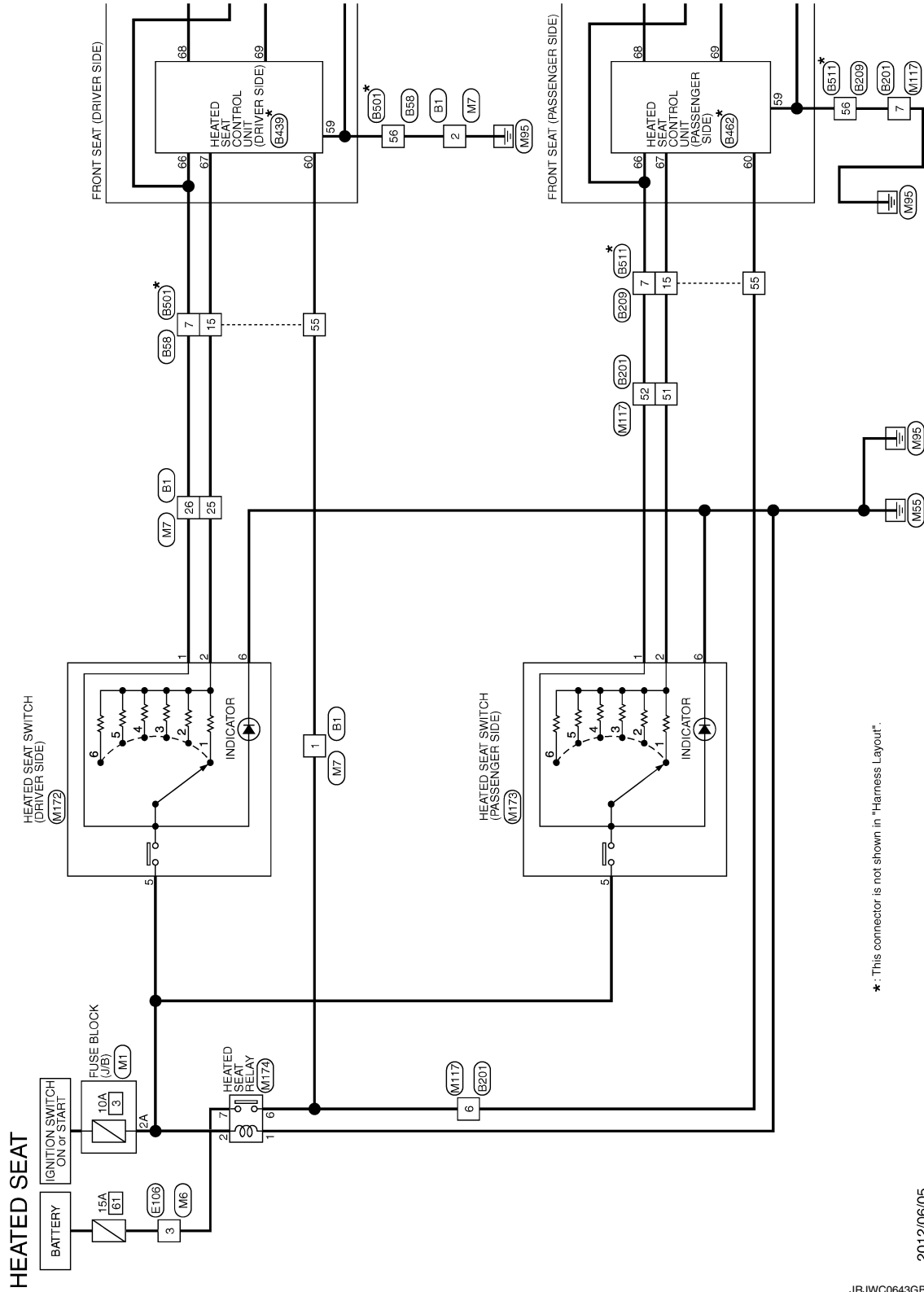

*: This connector is not shown in "Harness Layout".

2012/06/05

JRJWC0643GB

A
B
C
D
E
F
G
H
I
SE
K
L
M
N
O
P

HEATED SEAT CONTROL UNIT

< ECU DIAGNOSIS INFORMATION >

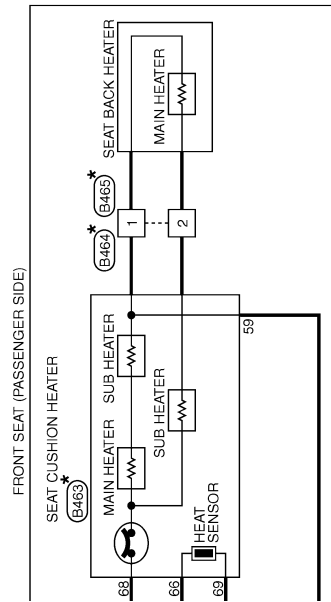
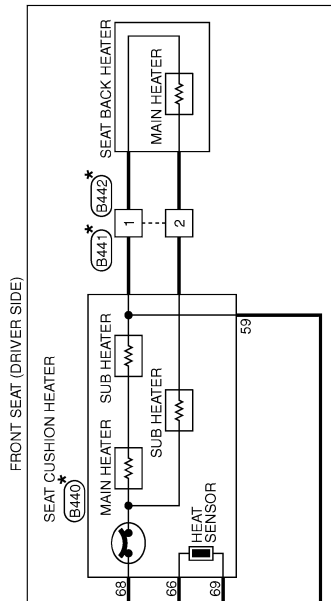

* : This connector is not shown in "Harness Layout".

JRJWC0644GB

HEATED SEAT CONTROL UNIT

< ECU DIAGNOSIS INFORMATION >

HEATED SEAT

Connector No.	B1
Connector Name	WIRE TO WIRE
Connector Type	TH80FM-CS16-TM4



Terminal No.	Color Of Wire	Signal Name [Specification]
1	G	-
2	W	-
3	G	-
4	P	-
5	BG	-
6	SB	-
7	SB	-
8	SB	-
9	SB	-
10	SB	-
11	SB	-
12	B	-
13	G	-
14	R	-
15	W	-
16	SHIELD	-
17	L	-
18	P	-
19	G	-
20	Y	-
21	W	-
23	V	-
24	P	-
25	BR	-
26	GR	-
27	BG	-
28	W	-
38	B	-
39	B	-
43	SB	-
44	V	-
45	GR	-
51	V	-
52	SB	-
53	SHIELD	-
54	BR	-
55	Y	-
56	SHIELD	-

Connector No.	B58
Connector Name	WIRE TO WIRE
Connector Type	NS10FM-CS

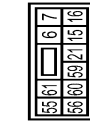

Terminal No.	Color Of Wire	Signal Name [Specification]
6	V	-
7	GR	-
15	BR	-
16	B	-
21	BG	-
55	G	-
56	L	-
59	LG	-
60	B	-
61	SB	-

Connector No.	B201
Connector Name	WIRE TO WIRE
Connector Type	TH80FM-CS16-TM4



Terminal No.	Color Of Wire	Signal Name [Specification]
1	G	-
2	R	-
3	BR	-
4	SB	-
6	BG	-
7	GR	-
8	W	-
10	G	-
11	SHIELD	-

20	L	-
21	P	-
22	GR	-
23	LG	-
24	W	-
25	V	-
26	G	-
27	Y	-
28	SHIELD	-
31	W	-
32	GR	-
33	SB	-
36	L	-
37	P	-
38	L	-
39	P	-
40	LG	- [With ICC] - [Without ICC]
41	SB	- [With ICC] - [Without ICC]
42	V	- [With ICC] - [Without ICC]
43	W	- [With ICC] - [Without ICC]
44	R	- [With ICC] - [Without ICC]
45	G	- [With ICC] - [Without ICC]
46	SHIELD	- [With ICC] - [Without ICC]
47	B	- [With ICC] - [Without ICC]
48	L	- [With ICC] - [Without ICC]
49	G	- [With ICC] - [Without ICC]
50	SHIELD	- [With ICC] - [Without ICC]
51	W	-
52	R	-
53	G	-
54	L	-
55	SB	-
60	GR	-
61	LG	-
62	SB	-
63	P	-
64	BR	-
65	BG	-
66	Y	-
67	W	-
69	G	-

A
B
C
D
E
F
G
H
I
SE
K
L
M
N
O
P

HEATED SEAT CONTROL UNIT

< ECU DIAGNOSIS INFORMATION >

HEATED SEAT		B462 HEATED SEAT CONTROL UNIT (PASSENGER SIDE)		B441 WIRE TO WIRE		B439 HEATED SEAT CONTROL UNIT (DRIVER SIDE)		B289 WIRE TO WIRE	
Terminal No.	Color Of Wire	Terminal No.	Wire	Terminal No.	Wire	Terminal No.	Wire	Terminal No.	Wire
71	SB	59	Y	1	-	59	Y/R	6	G
72	V	60	Y/R	2	-	60	Y/R	7	R
73	LG	66	B	-	-	66	B	15	W
74	W	67	L	-	-	67	L	16	L
75	BR	68	R/W	-	-	68	R/W	21	SB
76	V	69	R	-	-	69	R	55	BG
77	LG	-	-	-	-	-	-	56	GR
80	BG	-	-	-	-	-	-	59	V
82	P	-	-	-	-	-	-	60	B
83	Y	-	-	-	-	-	-	61	LG
84	R	-	-	-	-	-	-	-	-
85	SB	-	-	-	-	-	-	-	-
86	GR	-	-	-	-	-	-	-	-
87	L	-	-	-	-	-	-	-	-
91	V	-	-	-	-	-	-	-	-
92	W	-	-	-	-	-	-	-	-
93	R	-	-	-	-	-	-	-	-
94	LG	-	-	-	-	-	-	-	-
95	GR	-	-	-	-	-	-	-	-
96	W	-	-	-	-	-	-	-	-
97	G	-	-	-	-	-	-	-	-
98	BG	-	-	-	-	-	-	-	-
99	L	-	-	-	-	-	-	-	-

Terminal No.	Color Of Wire	Signal Name [Specification]
59	Y	Ground
60	Y/R	IGN power supply
66	B	Heated seat operation signal
67	L	Heated seat switch signal
68	R/W	Heater unit power supply
69	R	Heat sensor signal

Terminal No.	Color Of Wire	Signal Name [Specification]
1	-	-
2	-	-

Terminal No.	Color Of Wire	Signal Name [Specification]
1	-	-
2	-	-

Terminal No.	Color Of Wire	Signal Name [Specification]
59	Y	Ground
60	Y/R	IGN power supply
66	B	Heated seat operation signal
67	L	Heated seat switch signal
68	R/W	Heater unit power supply
69	R	Heat sensor signal

Terminal No.	Color Of Wire	Signal Name [Specification]
59	Y	Ground
66	B	Heated seat operation signal
67	L	Heated seat switch signal
68	R/W	Heater unit power supply
69	R	Heat sensor signal

Terminal No.	Color Of Wire	Signal Name [Specification]
6	G	-
7	R	-
15	W	-
16	L	-
21	SB	-
55	BG	-
56	GR	-
59	V	-
60	B	-
61	LG	-

Terminal No.	Color Of Wire	Signal Name [Specification]
59	Y	Ground
66	B	Heated seat operation signal
67	L	Heated seat switch signal
68	R/W	Heater unit power supply
69	R	Heat sensor signal

Terminal No.	Color Of Wire	Signal Name [Specification]
59	Y	Ground
66	B	Heated seat operation signal
67	L	Heated seat switch signal
68	R/W	Heater unit power supply
69	R	Heat sensor signal

Terminal No.	Color Of Wire	Signal Name [Specification]
1	-	-
2	-	-

Terminal No.	Color Of Wire	Signal Name [Specification]
1	-	-
2	-	-

Terminal No.	Color Of Wire	Signal Name [Specification]
59	Y	Ground
66	B	Heated seat operation signal
67	L	Heated seat switch signal
68	R/W	Heater unit power supply
69	R	Heat sensor signal

Terminal No.	Color Of Wire	Signal Name [Specification]
59	Y	Ground
66	B	Heated seat operation signal
67	L	Heated seat switch signal
68	R/W	Heater unit power supply
69	R	Heat sensor signal

JRJVW5579GB

HEATED SEAT CONTROL UNIT

< ECU DIAGNOSIS INFORMATION >

HEATED SEAT

Connector No.	B464
Connector Name	WIRE TO WIRE
Connector Type	MD2FW-LC

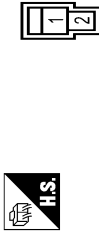

Terminal No.	Color Of Wire	Signal Name [Specification]
1	-	-
2	-	-

Connector No.	B465
Connector Name	WIRE TO WIRE
Connector Type	MD2MW-LC

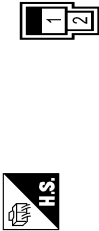

Terminal No.	Color Of Wire	Signal Name [Specification]
1	-	-
2	-	-

Connector No.	B501
Connector Name	WIRE TO WIRE
Connector Type	NS10MW-CS



Terminal No.	Color Of Wire	Signal Name [Specification]
6	R	-
7	L	-
15	W	-
16	G	-
21	P	-
55	B	-
56	B	-
59	L/Y	-
60	R/Y	-
61	B/Y	-

Connector No.	B511
Connector Name	WIRE TO WIRE
Connector Type	NS10MW-CS



Terminal No.	Color Of Wire	Signal Name [Specification]
6	R	-
7	L	-
15	W	-
16	G	-
21	P	-
55	W	-
56	B	-
59	L/Y	-
60	R/Y	-
61	B/Y	-

Connector No.	E106
Connector Name	WIRE TO WIRE
Connector Type	TH80FW-CS16-TM4

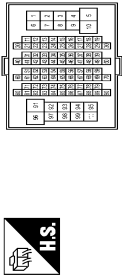

Terminal No.	Color Of Wire	Signal Name [Specification]
1	G	-
2	BG	-
3	SB	-
4	LG	-
5	Y	-
6	W	-
7	G	-
8	V	-
9	R	-
10	BR	-
11	B	-
12	G	-
13	R	-
14	W	-
15	SHIELD	-
16	SB	-
17	L	-
18	P	-
19	G	-
20	W	- [With ICC]
20	Y	- [Without ICC]
21	BR	-
22	R	- [With ICC]
22	V	- [Without ICC]
23	G	-
24	L	- [With ICC]
24	P	- [Without ICC]
25	L	- [Without ICC]
25	Y	- [With ICC]
26	SHIELD	-
28	LG	-
29	CG	-
30	RG	-
32	W	-
33	Y	-
34	BG	-

37	Y	-
38	GR	-
39	LG	-
41	LG	-
42	V	-
43	R	-
44	G	-
45	GR	-
46	W	-
47	L	-
48	P	-
49	SB	-
50	BR	-
51	B	-
52	Y	-
53	BG	-
54	R	-
55	SB	-
58	P	-
60	SB	-
61	V	-
62	P	-
63	LG	-
64	L	-
65	BG	-
69	L	-
70	SHIELD	-
71	G	-
72	G	-
73	R	-
74	BR	-
76	L	-
77	W	-
78	Y	-
80	SB	-
81	L	-
82	W	-
83	LG	-
84	GR	-
85	G	-
86	P	-
87	W	-
88	BG	-
89	LG	-
90	BR	-
91	GR	-
92	BR	-
93	SB	-
95	Y	-
96	W	-

A
B
C
D
E
F
G
H
I
SE
K
L
M
N
O
P

HEATED SEAT CONTROL UNIT

< ECU DIAGNOSIS INFORMATION >

HEATED SEAT

97	W	-
98	SHIELD	-
100	Y	-

Connector No.	M1
Connector Name	FUSE BLOCK (JIB)
Connector Type	NS08FW-M2

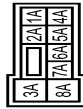

Terminal No.	Color Of Wire	Signal Name [Specification]
1A	BG	-
2A	G	-
3A	L	-
4A	R	-
5A	V	-
6A	Y	-
7A	R	-
8A	L	-

Connector No.	M6
Connector Name	WIRE TO WIRE
Connector Type	TH80MW-CS16-TM4



Terminal No.	Color Of Wire	Signal Name [Specification]
1	G	-
2	BG	-
3	LG	- [Without Auto aircon seat]
4	SB	- [Without Auto aircon seat]
5	LG	-
6	W	-

60	SB	-
61	V	-
62	P	-
63	R	-
64	L	-
65	BG	-
69	V	-
70	SHIELD	-
71	BG	-
72	GR	-
73	W	-
74	SB	-
76	V	-
77	V	-
78	Y	-
80	BG	-
81	L	-
82	W	-
83	Y	-
84	L	-
85	P	-
86	BR	-
87	P	-
88	V	-
89	G	-
90	P	-
91	R	-
92	R	-
93	GR	-
95	G	-
96	W	-
97	W	-
98	SHIELD	-
100	Y	-

Connector No.	M7
Connector Name	WIRE TO WIRE
Connector Type	TH80MW-CS16-TM4

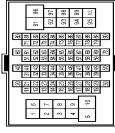

Terminal No.	Color Of Wire	Signal Name [Specification]
1	G	- [With Auto aircon seat]
1	Y	- [Without Auto aircon seat]
2	B	-
3	W	-
6	P	-
7	V	-
8	BG	-
10	W	-
11	BG	-
12	B	-
13	G	-
14	R	-
15	W	-
16	SHIELD	-
17	L	-
18	P	-
19	G	-
20	R	-
21	LG	-
23	V	-
24	P	-
25	BR	-
26	GR	-
27	BG	-
28	W	-
38	B	-
39	B	-
43	SB	-
44	W	-
45	B	-
51	V	-
52	LG	-
53	SHIELD	-
54	BR	-
55	Y	-
56	SHIELD	-

JRJWC5581GB

HEATED SEAT CONTROL UNIT

< ECU DIAGNOSIS INFORMATION >

HEATED SEAT

57	P	-	-	-	-
58	L	-	-	-	-
59	SHIELD	-	-	-	-
60	L	-	-	-	-
61	BR	-	-	-	-
62	R	-	-	-	-
63	Y	-	-	-	-
64	L	-	-	-	-
65	W	-	-	-	-
66	V	-	-	-	-
67	LG	-	-	-	-
68	Y	-	-	-	-
69	G	-	-	-	-
70	V	-	-	-	-
71	W	-	-	-	-
72	B	-	-	-	-
73	W	-	-	-	-
74	LG	-	-	-	-
75	P	-	-	-	-
76	LG	-	-	-	-
77	SB	-	-	-	-
78	GR	-	-	-	-
79	R	-	-	-	-
80	L	-	-	-	-
81	P	-	-	-	-
82	L	-	-	-	-
83	P	-	-	-	-
84	SB	-	-	-	-
85	W	-	-	-	-
86	Y	-	-	-	-
87	B	-	-	-	-
88	G	-	-	-	-
89	BG	-	-	-	-
91	R	-	-	-	-
92	BG	-	-	-	-
93	BR	-	-	-	-
94	V	-	-	-	-
96	BG	-	-	-	-
97	W	-	-	-	-
98	R	-	-	-	-
99	BG	-	-	-	-

Connector No.	M117
Connector Name	WIPE TO WIRE
Connector Type	TH80MW-CS16-TM4

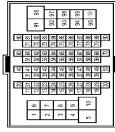

Terminal No.	Color Of Wire	Signal Name [Specification]
1	GR	-
2	BR	-
3	V	-
4	SB	-
6	Y	-
7	B	-
8	W	-
10	W	-
11	SHIELD	-
20	R	-
21	G	-
22	GR	-
23	V	-
24	W	-
25	R	-
26	P	-
27	L	-
28	SHIELD	-
31	W	-
32	W	-
33	SB	-
36	L	-
37	P	-
38	L	-
39	P	-
40	V	-
41	SB	- [Without ICC]
41	Y	- [With ICC]
42	V	- [Without ICC]
42	W	- [With ICC]
43	B	- [Without ICC]
43	P	- [With ICC]
44	R	- [Without ICC]
45	G	- [With ICC]
45	L	- [Without ICC]
46	BG	- [With ICC]

46	SHIELD	- [Without ICC]
47	B	- [Without ICC]
47	L	- [With ICC]
48	P	- [Without ICC]
48	R	- [With ICC]
49	G	- [Without ICC]
49	W	- [With ICC]
50	SHIELD	-
51	BG	-
52	GR	-
54	G	-
54	L	-
55	P	-
60	LG	-
61	R	-
62	SB	-
63	V	-
64	Y	-
66	BR	-
66	BG	-
67	W	-
69	G	-
71	SB	-
72	V	-
73	V	-
74	LG	-
75	BR	-
76	V	-
77	LG	-
80	R	-
82	Y	-
83	BG	-
84	W	-
85	SB	-
86	B	-
87	P	-
91	L	-
92	L	-
93	G	-
94	BG	-
95	V	-
96	G	-
97	G	-
98	L	-
99	LG	-

Connector No.	M172
Connector Name	HEATED SEAT SWITCH (DRIVER SIDE)
Connector Type	TK10FW

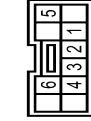

Terminal No.	Color Of Wire	Signal Name [Specification]
1	GR	-
2	BR	-
3	R	-
4	R	-
6	Y	-
6	B	-

Connector No.	M173
Connector Name	HEATED SEAT SWITCH (PASSENGER SIDE)
Connector Type	TK08FBR

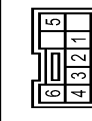

Terminal No.	Color Of Wire	Signal Name [Specification]
1	GR	-
2	BG	-
3	R	-
4	R	-
5	Y	-
6	B	-



A
B
C
D
E
F
G
H
I
SE
K
L
M
N
O
P

HEATED SEAT CONTROL UNIT

< ECU DIAGNOSIS INFORMATION >

HEATED SEAT

Connector No.	M174
Connector Name	HEATED SEAT RELAY
Connector Type	MO6FER-R-LC

Terminal No.	Color Of Wire	Signal Name [Specification]
1	B	-
2	Y	-
6	Y	-
7	LG	-

JRJWC5583GB

CLIMATE CONTROLLED SEAT DOES NOT OPERATE.

< SYMPTOM DIAGNOSIS >

SYMPTOM DIAGNOSIS

CLIMATE CONTROLLED SEAT DOES NOT OPERATE.
BOTH SIDES

BOTH SIDES : Diagnosis Procedure

INFOID:000000010584564

1.CHECK CLIMATE CONTROLLED CONTROL UNIT POWER SUPPLY AND GROUND CIRCUIT

Check climate controlled control unit power supply and ground circuit.

Refer to [SE-17. "CLIMATE CONTROLLED SEAT CONTROL UNIT : Diagnosis Procedure"](#).

Is the inspection result normal?

YES >> GO TO 2.

NO >> Repair or replace the malfunctioning parts.

2.CONFIRM THE OPERATION

Confirm the operation again.

Is the inspection result normal?

YES >> Check intermittent incident. Refer to [GI-47. "Intermittent Incident"](#).

NO >> GO TO 1.

DRIVER SIDE

DRIVER SIDE : Diagnosis Procedure

INFOID:000000010584565

1.CHECK CLIMATE CONTROLLED SEAT CONTROL UNIT POWER SUPPLY CIRCUIT

Check climate controlled seat control unit power supply circuit.

Refer to [SE-17. "CLIMATE CONTROLLED SEAT CONTROL UNIT : Diagnosis Procedure"](#).

Is the inspection result normal?

YES >> GO TO 2.

NO >> Repair or replace the malfunctioning parts.

2.CHECK CLIMATE CONTROLLED SEAT SWITCH

Check climate controlled seat switch.

Refer to [SE-22. "Component Function Check"](#).

Is the inspection result normal?

YES >> GO TO 3.

NO >> Repair or replace the malfunctioning parts.

3.CHECK CLIMATE CONTROLLED SEAT BLOWER MOTOR

Check climate controlled seat blower motor.

Refer to [SE-33. "Component Function Check"](#).

Is the inspection result normal?

YES >> GO TO 4.

NO >> Repair or replace the malfunctioning parts.

4.CONFIRM THE OPERATION

Confirm the operation again.

Is the inspection result normal?

YES >> Check intermittent incident. Refer to [GI-47. "Intermittent Incident"](#).

NO >> GO TO 1.

PASSENGER SIDE

PASSENGER SIDE : Diagnosis Procedure

INFOID:000000010584566

1.CHECK CLIMATE CONTROLLED SEAT CONTROL UNIT POWER SUPPLY AND GROUND CIRCUIT

Check climate controlled seat control unit power supply circuit.

A
B
C
D
E
F
G
H
I
K
L
M
N
O
P

SE

CLIMATE CONTROLLED SEAT DOES NOT OPERATE.

< SYMPTOM DIAGNOSIS >

Refer to [SE-17, "CLIMATE CONTROLLED SEAT CONTROL UNIT : Diagnosis Procedure"](#).

Is the inspection result normal?

YES >> GO TO 2.

NO >> Repair or replace the malfunctioning parts.

2.CHECK CLIMATE CONTROLLED SEAT SWITCH

Check climate controlled seat switch.

Refer to [SE-22, "Component Function Check"](#).

Is the inspection result normal?

YES >> GO TO 3.

NO >> Repair or replace the malfunctioning parts.

3.CHECK CLIMATE CONTROLLED SEAT BLOWER MOTOR

Check climate controlled seat blower motor.

Refer to [SE-33, "Component Function Check"](#).

Is the inspection result normal?

YES >> GO TO 4.

NO >> Repair or replace the malfunctioning parts.

4.CONFIRM THE OPERATION

Confirm the operation again.

Is the inspection result normal?

YES >> Check intermittent incident. Refer to [GI-47, "Intermittent Incident"](#).

NO >> GO TO 1.

CLIMATE CONTROLLED SEAT BLOWER MOTOR SPEED CANNOT ADJUST.

< SYMPTOM DIAGNOSIS >

CLIMATE CONTROLLED SEAT BLOWER MOTOR SPEED CANNOT ADJUST.

Diagnosis Procedure

INFOID:000000010584567

1. CHECK CLIMATE CONTROLLED SEAT BLOWER FILTER

Check climate controlled seat blower filter.

Refer to [SE-39, "Diagnosis Procedure"](#).

Is the inspection result normal?

YES >> GO TO 2.

NO >> Repair or replace the malfunctioning parts.

2. CHECK CLIMATE CONTROLLED SEAT SWITCH

Check climate controlled seat switch.

Refer to [SE-22, "Component Function Check"](#).

Is the inspection result normal?

YES >> GO TO 3.

NO >> Repair or replace the malfunctioning parts.

3. CHECK CLIMATE CONTROLLED SEAT BLOWER MOTOR

Check climate controlled seat blower motor.

Refer to [SE-33, "Component Function Check"](#).

Is the inspection result normal?

YES >> GO TO 4.

NO >> Repair or replace the malfunctioning parts.

4. CONFIRM THE OPERATION

Confirm the operation again.

Is the inspection result normal?

YES >> Check intermittent incident. Refer to [GI-47, "Intermittent Incident"](#).

NO >> GO TO 1.

A
B
C
D
E
F
G
H
I
K
L
M
N
O
P

SE

CLIMATE CONTROLLED SEAT DOES NOT OPERATES WHEN SWITCH IS DONE IN HEAT OR COOL.

< SYMPTOM DIAGNOSIS >

CLIMATE CONTROLLED SEAT DOES NOT OPERATES WHEN SWITCH IS DONE IN HEAT OR COOL.

Diagnosis Procedure

INFOID:000000010584568

1.CHECK CLIMATE CONTROLLED SEAT SWITCH

Check climate controlled seat switch.

Refer to [SE-22, "Component Function Check"](#).

Is the inspection result normal?

YES >> GO TO 2.

NO >> Repair or replace the malfunctioning parts.

2.CONFIRM THE OPERATION

Confirm the operation again.

Is the inspection result normal?

YES >> Check intermittent incident. Refer to [GI-47, "Intermittent Incident"](#).

NO >> GO TO 1.

WHEN THE CLIMATE CONTROLLED SEAT SWITCH IS TURNED ON, OPERATION STOP AT NOSE.

< SYMPTOM DIAGNOSIS >

WHEN THE CLIMATE CONTROLLED SEAT SWITCH IS TURNED ON, OPERATION STOP AT NOSE.

Diagnosis Procedure

INFOID:000000010584569

1.CHECK CLIMATE CONTROLLED SEAT BLOWER FILTER

Check climate controlled seat blower filter.

Refer to [SE-39, "Diagnosis Procedure"](#).

Is the inspection result normal?

YES >> GO TO 2.

NO >> Repair or replace the malfunctioning parts.

2.CHECK SEAT CUSHION THERMAL ELECTRIC DEVICE SENSOR

Check seat cushion thermal electric device sensor.

Refer to [SE-31, "Diagnosis Procedure"](#).

Is the inspection result normal?

YES >> GO TO 3.

NO >> Repair or replace the malfunctioning parts.

3.CHECK SEAT CUSHION THERMAL ELECTRIC DEVICE

Check seat cushion thermal electric device.

Refer to [SE-29, "Component Function Check"](#).

Is the inspection result normal?

YES >> GO TO 4.

NO >> Repair or replace the malfunctioning parts.

4.CHECK SEATBACK THERMAL ELECTRIC DEVICE SENSOR

Check seatback thermal electric device sensor.

Refer to [SE-27, "Diagnosis Procedure"](#).

Is the inspection result normal?

YES >> GO TO 5.

NO >> Repair or replace the malfunctioning parts.

5.CHECK SEATBACK THERMAL ELECTRIC DEVICE

Check seatback thermal electric device.

Refer to [SE-25, "Component Function Check"](#).

Is the inspection result normal?

YES >> GO TO 6.

NO >> Repair or replace the malfunctioning parts.

6.CHECK CLIMATE CONTROLLED BLOWER MOTOR

Check climate controlled blower motor.

Refer to [SE-33, "Component Function Check"](#).

Is the inspection result normal?

YES >> GO TO 7.

NO >> Repair or replace the malfunctioning parts.

7.CONFIRM THE OPERATION

Confirm the operation again.

Is the inspection result normal?

YES >> Check intermittent incident. Refer to [GI-47, "Intermittent Incident"](#).

NO >> GO TO 1.

A
B
C
D
E
F
G
H
I
SE
K
L
M
N
O
P

SEAT SWITCH INDICATOR DOES NOT OPERATE IN HEAT OR COOL POSITION

< SYMPTOM DIAGNOSIS >

SEAT SWITCH INDICATOR DOES NOT OPERATE IN HEAT OR COOL POSITION

Diagnosis Procedure

INFOID:000000010584570

1. CHECK CLIMATE CONTROLLED SEAT SWITCH INDICATOR

Check climate controlled seat indicator.

Refer to [SE-36, "Component Function Check"](#).

Is the inspection result normal?

YES >> GO TO 2.

NO >> Repair or replace the malfunctioning parts.

2. CONFIRM THE OPERATION

Confirm the operation again.

Is the inspection result normal?

YES >> Check intermittent incident. Refer to [GI-47, "Intermittent Incident"](#).

NO >> GO TO 1.

HEATED SEAT DOES NOT OPERATE

< SYMPTOM DIAGNOSIS >

HEATED SEAT DOES NOT OPERATE BOTH SIDES

BOTH SIDES : Diagnosis Procedure

INFOID:000000010584571

1.CHECK HEATED SEAT SWITCH POWER SUPPLY

Check heated seat switch power supply.

Refer to [SE-16. "HEATED SEAT SWITCH : Diagnosis Procedure"](#).

Is the inspection result normal?

YES >> GO TO 2.

NO >> Repair or replace the malfunctioning parts.

2.CHECK HEATED SEAT RELAY

Check heated seat relay.

Refer to [SE-44. "Component Function Check"](#).

Is the inspection result normal?

YES >> GO TO 3.

NO >> Repair or replace the malfunctioning parts.

3.CHECK HEATED SEAT CONTROL UNIT POWER SUPPLY AND GROUND CIRCUIT

Check heated seat switch power supply and ground circuit.

Refer to [SE-14. "HEATED SEAT CONTROL UNIT : Diagnosis Procedure"](#).

Is the inspection result normal?

YES >> GO TO 4.

NO >> Repair or replace the malfunctioning parts.

4.CONFIRM THE OPERATION

Confirm the operation again.

Is the inspection result normal?

YES >> Check intermittent incident. Refer to [GI-47. "Intermittent Incident"](#).

NO >> GO TO 1.

DRIVER SIDE

DRIVER SIDE : Diagnosis Procedure

INFOID:000000010584572

1.CHECK HEATED SEAT SWITCH POWER SUPPLY

Check heated seat switch power supply.

Refer to [SE-16. "HEATED SEAT SWITCH : Diagnosis Procedure"](#).

Is the inspection result normal?

YES >> GO TO 2.

NO >> Repair or replace the malfunctioning parts.

2.CHECK HEATED SEAT CONTROL UNIT POWER SUPPLY AND GROUND CIRCUIT

Check heated seat switch power supply and ground circuit.

Refer to [SE-14. "HEATED SEAT CONTROL UNIT : Diagnosis Procedure"](#).

Is the inspection result normal?

YES >> GO TO 3.

NO >> Repair or replace the malfunctioning parts.

3.CHECK HEATED SEAT SWITCH

Check heated seat switch.

Refer to [SE-40. "DRIVER SIDE : Component Function Check"](#).

Is the inspection result normal?

YES >> GO TO 4.

NO >> Repair or replace the malfunctioning parts.

A

B

C

D

E

F

G

H

I

SE

K

L

M

N

O

P

HEATED SEAT DOES NOT OPERATE

< SYMPTOM DIAGNOSIS >

4.CHECK SEAT CUSHION HEATER

Check seat cushion heater.

Refer to [SE-51, "DRIVER SIDE : Component Function Check"](#).

Is the inspection result normal?

YES >> GO TO 5.

NO >> Repair or replace the malfunctioning parts.

5.CONFIRM THE OPERATION

Confirm the operation again.

Is the inspection result normal?

YES >> Check intermittent incident. Refer to [GI-47, "Intermittent Incident"](#).

NO >> GO TO 1.

PASSENGER SIDE

PASSENGER SIDE : Diagnosis Procedure

INFOID:0000000010584573

1.CHECK HEATED SEAT SWITCH POWER SUPPLY

Check heated seat switch power supply.

Refer to [SE-16, "HEATED SEAT SWITCH : Diagnosis Procedure"](#).

Is the inspection result normal?

YES >> GO TO 2.

NO >> Repair or replace the malfunctioning parts.

2.CHECK HEATED SEAT CONTROL UNIT POWER SUPPLY AND GROUND CIRCUIT

Check heated seat switch power supply and ground circuit.

Refer to [SE-14, "HEATED SEAT CONTROL UNIT : Diagnosis Procedure"](#).

Is the inspection result normal?

YES >> GO TO 3.

NO >> Repair or replace the malfunctioning parts.

3.CHECK HEATED SEAT SWITCH

Check heated seat switch.

Refer to [SE-41, "PASSENGER SIDE : Component Function Check"](#).

Is the inspection result normal?

YES >> GO TO 4.

NO >> Repair or replace the malfunctioning parts.

4.CHECK SEAT CUSHION HEATER

Check seat cushion heater.

Refer to [SE-52, "PASSENGER SIDE : Component Function Check"](#).

Is the inspection result normal?

YES >> GO TO 5.

NO >> Repair or replace the malfunctioning parts.

5.CONFIRM THE OPERATION

Confirm the operation again.

Is the inspection result normal?

YES >> Check intermittent incident. Refer to [GI-47, "Intermittent Incident"](#).

NO >> GO TO 1.

SEATBACK HEATER ONLY DOES NOT OPERATE

< SYMPTOM DIAGNOSIS >

SEATBACK HEATER ONLY DOES NOT OPERATE DRIVER SIDE

DRIVER SIDE : Diagnosis Procedure

INFOID:000000010584574

1.CHECK SEATBACK HEATER

Check seatback heater.

Refer to [SE-55, "DRIVER SIDE : Component Function Check"](#).

Is the inspection result normal?

YES >> GO TO 2.

NO >> Repair or replace the malfunctioning parts.

2.CONFIRM THE OPERATION

Confirm the operation again.

Is the inspection result normal?

YES >> Check intermittent incident. Refer to [GI-47, "Intermittent Incident"](#).

NO >> GO TO 1.

PASSENGER SIDE

PASSENGER SIDE : Diagnosis Procedure

INFOID:000000010584575

1.CHECK SEATBACK HEATER

Check seatback heater.

Refer to [SE-55, "PASSENGER SIDE : Component Function Check"](#).

Is the inspection result normal?

YES >> GO TO 2.

NO >> Repair or replace the malfunctioning parts.

2.CONFIRM THE OPERATION

Confirm the operation again.

Is the inspection result normal?

YES >> Check intermittent incident. Refer to [GI-47, "Intermittent Incident"](#).

NO >> GO TO 1.

A
B
C
D
E
F
G
H
I
SE
K
L
M
N
O
P

CANNOT ADJUST HEATED SEAT TEMPERATURE

< SYMPTOM DIAGNOSIS >

CANNOT ADJUST HEATED SEAT TEMPERATURE DRIVER SIDE

DRIVER SIDE : Diagnosis Procedure

INFOID:0000000010584576

1.CHECK HEATED SEAT SWITCH

Check heated seat switch.

Refer to [SE-40, "DRIVER SIDE : Component Function Check"](#).

Is the inspection result normal?

YES >> GO TO 2.

NO >> Repair or replace the malfunctioning parts.

2.CHECK HEAT SENSOR

Check heat sensor.

Refer to [SE-46, "DRIVER SIDE : Description"](#).

Is the inspection result normal?

YES >> GO TO 3.

NO >> Repair or replace the malfunctioning parts.

3.CONFIRM THE OPERATION

Confirm the operation again.

Is the inspection result normal?

YES >> Check intermittent incident. Refer to [GI-47, "Intermittent Incident"](#).

NO >> Replace heated seat control unit. Refer to [SE-150, "Removal and Installation"](#).

PASSENGER SIDE

PASSENGER SIDE : Diagnosis Procedure

INFOID:0000000010584577

1.CHECK HEATED SEAT SWITCH

Check heated seat switch.

Refer to [SE-41, "PASSENGER SIDE : Component Function Check"](#).

Is the inspection result normal?

YES >> GO TO 2.

NO >> Repair or replace the malfunctioning parts.

2.CHECK HEAT SENSOR

Check heat sensor.

Refer to [SE-48, "PASSENGER SIDE : Diagnosis Procedure"](#).

Is the inspection result normal?

YES >> GO TO 3.

NO >> Repair or replace the malfunctioning parts.

3.CONFIRM THE OPERATION

Confirm the operation again.

Is the inspection result normal?

YES >> Check intermittent incident. Refer to [GI-47, "Intermittent Incident"](#).

NO >> Replace heated seat control unit. Refer to [SE-150, "Removal and Installation"](#).

HEATED SEAT SWITCH INDICATOR DOES NOT TURN ON

< SYMPTOM DIAGNOSIS >

HEATED SEAT SWITCH INDICATOR DOES NOT TURN ON DRIVER SIDE

DRIVER SIDE : Diagnosis Procedure

INFOID:000000010584578

1.CHECK HEATED SEAT SWITCH INDICATOR

Check heated seat switch indicator.

Refer to [SE-57, "DRIVER SIDE : Component Function Check"](#).

Is the inspection result normal?

YES >> GO TO 2.

NO >> Repair or replace the malfunctioning parts.

2.CONFIRM THE OPERATION

Confirm the operation again.

Is the inspection result normal?

YES >> Check intermittent incident. Refer to [GI-47, "Intermittent Incident"](#).

NO >> GO TO 1.

PASSENGER SIDE

PASSENGER SIDE : Diagnosis Procedure

INFOID:000000010584579

1.CHECK HEATED SEAT SWITCH INDICATOR

Check heated seat switch indicator.

Refer to [SE-58, "PASSENGER SIDE : Component Function Check"](#).

Is the inspection result normal?

YES >> GO TO 2.

NO >> Repair or replace the malfunctioning parts.

2.CONFIRM THE OPERATION

Confirm the operation again.

Is the inspection result normal?

YES >> Check intermittent incident. Refer to [GI-47, "Intermittent Incident"](#).

NO >> GO TO 1.

A
B
C
D
E
F
G
H
I
SE
K
L
M
N
O
P

SQUEAK AND RATTLE TROUBLE DIAGNOSES

< SYMPTOM DIAGNOSIS >

SQUEAK AND RATTLE TROUBLE DIAGNOSES

Work Flow

INFOID:000000010584580

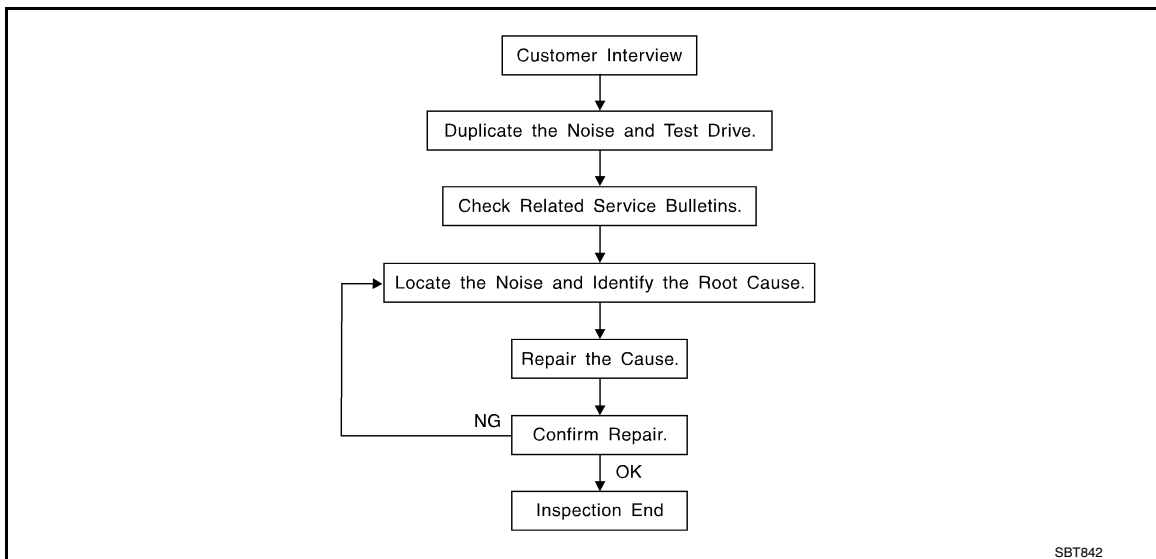

CUSTOMER INTERVIEW

Interview the customer if possible, to determine the conditions that exist when the noise occurs. Use the Diagnostic Worksheet during the interview to document the facts and conditions when the noise occurs and any of customer's comments; refer to [SE-116, "Diagnostic Worksheet"](#). This information is necessary to duplicate the conditions that exist when the noise occurs.

- The customer may not be able to provide a detailed description or the location of the noise. Attempt to obtain all the facts and conditions that exist when the noise occurs (or does not occur).
- If there is more than one noise in the vehicle, perform a diagnosis and repair the noise that the customer is concerned about. This can be accomplished by performing a cruise test on the vehicle with the customer.
- After identifying the type of noise, isolate the noise in terms of its characteristics. The noise characteristics are provided so the customer, service adviser and technician are all speaking the same language when defining the noise.
- Squeak – (Like tennis shoes on a clean floor)
Squeak characteristics include the light contact/fast movement/brought on by road conditions/hard surfaces = higher pitch noise/softer surfaces = lower pitch noises/edge to surface = chirping
- Creak – (Like walking on an old wooden floor)
Creak characteristics include firm contact/slow movement/twisting with a rotational movement/pitch dependent on materials/often brought on by activity.
- Rattle – (Like shaking a baby rattle)
Rattle characteristics include the fast repeated contact/vibration or similar movement/loose parts/missing clip or fastener/incorrect clearance.
- Knock – (Like a knock on a door)
Knock characteristics include hollow sounding/sometimes repeating/often brought on by driver action.
- Tick – (Like a clock second hand)
Tick characteristics include gentle contacting of light materials/loose components/can be caused by driver action or road conditions.
- Thump – (Heavy, muffled knock noise)
Thump characteristics include softer knock/dead sound often brought on by activity.
- Buzz – (Like a bumblebee)
Buzz characteristics include high frequency rattle/firm contact.
- Often the degree of acceptable noise level will vary depending up on the person. A noise that a technician may judge as acceptable may be very irritating to the customer.
- Weather conditions, especially humidity and temperature, may have a great effect on noise level.

DUPLICATE THE NOISE AND TEST DRIVE

If possible, drive the vehicle with the customer until the noise is duplicated. Note any additional information on the Diagnostic Worksheet regarding the conditions or location of the noise. This information can be used to duplicate the same conditions when the repair is reconfirmed.

SQUEAK AND RATTLE TROUBLE DIAGNOSES

< SYMPTOM DIAGNOSIS >

If the noise can be duplicated easily during the test drive, to help identify the source of the noise, try to duplicate the noise with the vehicle stopped by doing one or all of the following:

- 1) Close a door.
 - 2) Tap or push/pull around the area where the noise appears to be coming from.
 - 3) Rev the engine.
 - 4) Use a floor jack to recreate vehicle "twist".
 - 5) At idle, apply engine load (electrical load, half-clutch on M/T models, drive position on A/T models).
 - 6) Raise the vehicle on a hoist and hit a tire with a rubber hammer.
- Drive the vehicle and attempt to duplicate the conditions the customer states exist when the noise occurs.
 - If it is difficult to duplicate the noise, drive the vehicle slowly on an undulating or rough road to stress the vehicle body.

CHECK RELATED SERVICE BULLETINS

After verifying the customer concern or symptom, check ASIST for Technical Service Bulletins (TSBs) related to that concern or symptom.

If a TSB relates to the symptom, follow the procedure to repair the noise.

LOCATE THE NOISE AND IDENTIFY THE ROOT CAUSE

1. Narrow down the noise to a general area. To help pinpoint the source of the noise, use a listening tool (Chassis ear: J-39570, Engine ear and mechanics stethoscope).
2. Narrow down the noise to a more specific area and identify the cause of the noise by:
 - Removing the components in the area that is are suspected to be the cause of the noise.
Do not use too much force when removing clips and fasteners, otherwise clips and fastener can be broken or lost during the repair, resulting in the creation of new noise.
 - Tapping or pushing/pulling the component that is are suspected to be the cause of the noise.
Do not tap or push/pull the component with excessive force, otherwise the noise will be eliminated only temporarily.
 - Feeling for a vibration by hand by touching the component(s) that is are suspected to be the cause of the noise.
 - Placing a piece of paper between components that are suspected to be the cause of the noise.
 - Looking for loose components and contact marks.
Refer to [SE-114, "Inspection Procedure"](#).

REPAIR THE CAUSE

- If the cause is a loose component, tighten the component securely.
- If the cause is insufficient clearance between components:
 - Separate components by repositioning or loosening and retightening the component, if possible.
 - Insulate components with a suitable insulator such as urethane pads, foam blocks, felt cloth tape or urethane tape. A Nissan Squeak and Rattle Kit (J-50397) is available through the authorized Nissan Parts Department.

CAUTION:

Never use excessive force as many components are constructed of plastic and may be damaged.

NOTE:

Always check with the Parts Department for the latest parts information.

The following materials are contained in the Nissan Squeak and Rattle Kit (J-50397). Each item can be ordered separately as needed.

URETHANE PADS [1.5 mm (0.059 in) thick]

Insulates connectors, harness, etc.

76268-9E005: 100 × 135 mm (3.94 × 5.31 in)/76884-71L01: 60 × 85 mm (2.36 × 3.35 in)/76884-71L02: 15 × 25 mm (0.59 × 0.98 in)

INSULATOR (Foam blocks)

Insulates components from contact. Can be used to fill space behind a panel.

73982-9E000: 45 mm (1.77 in) thick, 50 × 50 mm (1.97 × 1.97 in)/73982-

50Y00: 10 mm (0.39 in) thick, 50 × 50 mm (1.97 × 1.97 in)

INSULATOR (Light foam block)

80845-71L00: 30 mm (1.18 in) thick, 30 × 50 mm (1.18 × 1.97in)

FELT CLOTHTAPE

Used to insulate where movement does not occur. Ideal for instrument panel applications.

68370-4B000: 15 × 25 mm (0.59 × 0.98 in) pad/68239-13E00: 5 mm (0.20 in) wide tape roll

The following materials, not found in the kit, can also be used to repair squeaks and rattles.

UHMW (TEFLON) TAPE

SQUEAK AND RATTLE TROUBLE DIAGNOSES

< SYMPTOM DIAGNOSIS >

Insulates where slight movement is present. Ideal for instrument panel applications.

SILICONE GREASE

Used in place of UHMW tape that is be visible or does not fit. Will only last a few months.

SILICONE SPRAY

Used when grease cannot be applied.

DUCT TAPE

Used to eliminate movement.

CONFIRM THE REPAIR

Confirm that the cause of a noise is repaired by test driving the vehicle. Operate the vehicle under the same conditions as when the noise originally occurred. Refer to the notes on the Diagnostic Worksheet.

Inspection Procedure

INFOID:000000010584581

Refer to Table of Contents for specific component removal and installation information.

INSTRUMENT PANEL

Most incidents are caused by contact and movement between:

1. The cluster lid A and instrument panel
2. Acrylic lens and combination meter housing
3. Instrument panel to front pillar garnish
4. Instrument panel to windshield
5. Instrument panel mounting pins
6. Wiring harnesses behind the combination meter
7. A/C defroster duct and duct joint

These incidents can usually be located by tapping or moving the components to duplicate the noise or by pressing on the components while driving to stop the noise. Most of these incidents can be repaired by applying felt cloth tape or silicon spray (in hard to reach areas). Urethane pads can be used to insulate wiring harness.

CAUTION:

Never use silicone spray to isolate a squeak or rattle. If the area is saturated with silicone, the recheck of repair becomes impossible.

CENTER CONSOLE

Components to pay attention to include:

1. Shifter assembly cover to finisher
2. A/C control unit and cluster lid C
3. Wiring harnesses behind audio and A/C control unit

The instrument panel repair and isolation procedures also apply to the center console.

DOORS

Pay attention to the following:

1. Finisher and inner panel making a slapping noise
2. Inside handle escutcheon to door finisher
3. Wiring harnesses tapping
4. Door striker out of alignment causing a popping noise on starts and stops

Tapping or moving the components or pressing on them while driving to duplicate the conditions can isolate many of these incidents. The areas can usually be insulated with felt cloth tape or insulator foam blocks from the Nissan Squeak and Rattle Kit (J-50397) to repair the noise.

TRUNK

Trunk noises are often caused by a loose jack or loose items put into the trunk by the customer.

In addition look for the following:

1. Trunk lid dumpers out of adjustment
2. Trunk lid striker out of adjustment
3. The trunk lid torsion bars knocking together
4. A loose license plate or bracket

SQUEAK AND RATTLE TROUBLE DIAGNOSES

< SYMPTOM DIAGNOSIS >

Most of these incidents can be repaired by adjusting, securing or insulating the item(s) or component(s) causing the noise.

SUNROOF/HEADLINING

Noises in the sunroof/headlining area can often be traced to one of the following:

1. Sunroof lid, rail, linkage or seals making a rattle or light knocking noise
2. Sunvisor shaft shaking in the holder
3. Front or rear windshield touching headlining and squeaking

Again, pressing on the components to stop the noise while duplicating the conditions can isolate most of these incidents. Repairs usually consist of insulating with felt cloth tape.

SEATS

When isolating seat noise it's important to note the position the seats in and the load placed on the seat when the noise occurs. These conditions should be duplicated when verifying and isolating the cause of the noise.

Cause of seat noise include:

1. Headrest rods and holder
2. A squeak between the seat pad cushion and frame
3. The rear seatback lock and bracket

These noises can be isolated by moving or pressing on the suspected components while duplicating the conditions under which the noise occurs. Most of these incidents can be repaired by repositioning the component or applying urethane tape to the contact area.

UNDERHOOD

Some interior noise may be caused by components under the hood or on the engine wall. The noise is then transmitted into the passenger compartment.

Causes of transmitted underhood noise include:

1. Any component mounted to the engine wall
2. Components that pass through the engine wall
3. Engine wall mounts and connectors
4. Loose radiator mounting pins
5. Hood bumpers out of adjustment
6. Hood striker out of adjustment

These noises can be difficult to isolate since they cannot be reached from the interior of the vehicle. The best method is to secure, move or insulate one component at a time and test drive the vehicle. Also, engine RPM or load can be changed to isolate the noise. Repairs can usually be made by moving, adjusting, securing, or insulating the component causing the noise.

A
B
C
D
E
F
G
H
I
K
L
M
N
O
P

SE

SQUEAK AND RATTLE TROUBLE DIAGNOSES

< SYMPTOM DIAGNOSIS >

Diagnostic Worksheet

INFOID:000000010584582



SQUEAK & RATTLE DIAGNOSTIC WORKSHEET

Dear Infiniti Customer:

We are concerned about your satisfaction with your Infiniti vehicle. Repairing a squeak or rattle sometimes can be very difficult. To help us fix your Infiniti right the first time, please take a moment to note the area of the vehicle where the squeak or rattle occurs and under what conditions. You may be asked to take a test drive with a service consultant or technician to ensure we confirm the noise you are hearing.

I. WHERE DOES THE NOISE COME FROM? (circle the area of the vehicle)

The illustrations are for reference only, and may not reflect the actual configuration of your vehicle.

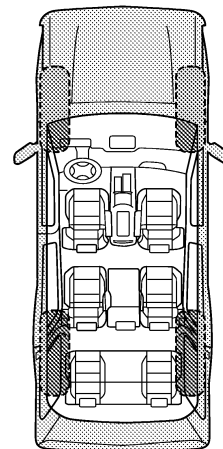
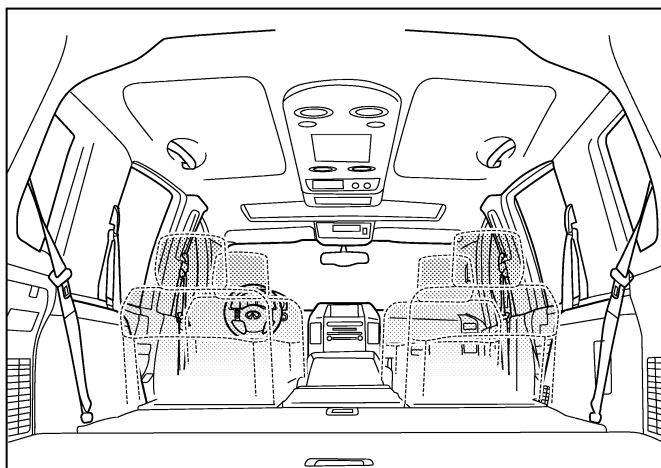
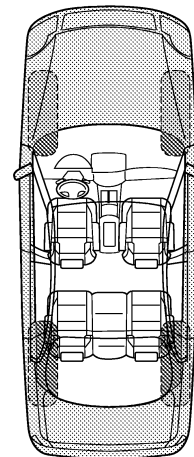
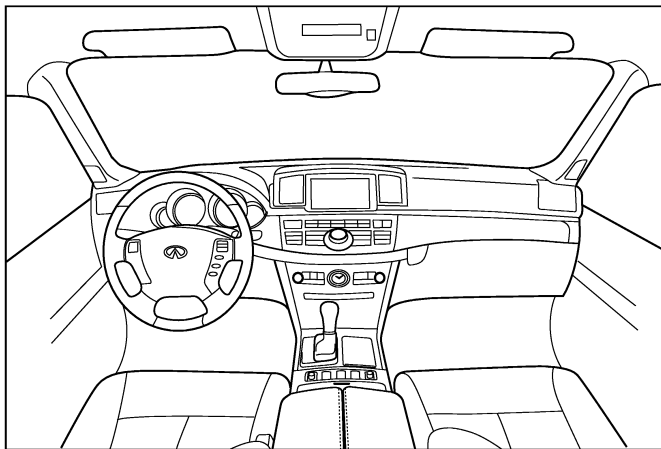

Continue to page 2 of the worksheet and briefly describe the location of the noise or rattle. In addition, please indicate the conditions which are present when the noise occurs.

PIIB8741E

SQUEAK AND RATTLE TROUBLE DIAGNOSES

< SYMPTOM DIAGNOSIS >

SQUEAK & RATTLE DIAGNOSTIC WORKSHEET - page 2

Briefly describe the location where the noise occurs:

II. WHEN DOES IT OCCUR? (please check the boxes that apply)

- | | |
|---|--|
| <input type="checkbox"/> anytime | <input type="checkbox"/> after sitting out in the rain |
| <input type="checkbox"/> 1st time in the morning | <input type="checkbox"/> when it is raining or wet |
| <input type="checkbox"/> only when it is cold outside | <input type="checkbox"/> dry or dusty conditions |
| <input type="checkbox"/> only when it is hot outside | <input type="checkbox"/> other: |

III. WHEN DRIVING:

- through driveways
- over rough roads
- over speed bumps
- only about ____ mph
- on acceleration
- coming to a stop
- on turns: left, right or either (circle)
- with passengers or cargo
- other: _____
- after driving ____ miles or ____ minutes

IV. WHAT TYPE OF NOISE

- squeak (like tennis shoes on a clean floor)
- creak (like walking on an old wooden floor)
- rattle (like shaking a baby rattle)
- knock (like a knock at the door)
- tick (like a clock second hand)
- thump (heavy, muffled knock noise)
- buzz (like a bumble bee)

TO BE COMPLETED BY DEALERSHIP PERSONNEL

Test Drive Notes:

	YES	NO	Initials of person performing
Vehicle test driven with customer	<input type="checkbox"/>	<input type="checkbox"/>	_____
- Noise verified on test drive	<input type="checkbox"/>	<input type="checkbox"/>	_____
- Noise source located and repaired	<input type="checkbox"/>	<input type="checkbox"/>	_____
- Follow up test drive performed to confirm repair	<input type="checkbox"/>	<input type="checkbox"/>	_____

VIN: _____ Customer Name: _____
W.O.# _____ Date: _____

This form must be attached to Work Order

PIIB8742E

A
B
C
D
E
F
G
H
I
SE
K
L
M
N
O
P

PRECAUTIONS

< PRECAUTION >

PRECAUTION

PRECAUTIONS

Precaution for Supplemental Restraint System (SRS) "AIR BAG" and "SEAT BELT PRE-TENSIONER"

INFOID:000000010584583

The Supplemental Restraint System such as "AIR BAG" and "SEAT BELT PRE-TENSIONER", used along with a front seat belt, helps to reduce the risk or severity of injury to the driver and front passenger for certain types of collision. This system includes seat belt switch inputs and dual stage front air bag modules. The SRS system uses the seat belt switches to determine the front air bag deployment, and may only deploy one front air bag, depending on the severity of a collision and whether the front occupants are belted or unbelted. Information necessary to service the system safely is included in the "SRS AIR BAG" and "SEAT BELT" of this Service Manual.

WARNING:

Always observe the following items for preventing accidental activation.

- To avoid rendering the SRS inoperative, which could increase the risk of personal injury or death in the event of a collision that would result in air bag inflation, all maintenance must be performed by an authorized NISSAN/INFINITI dealer.
- Improper maintenance, including incorrect removal and installation of the SRS, can lead to personal injury caused by unintentional activation of the system. For removal of Spiral Cable and Air Bag Module, see "SRS AIR BAG".
- Never use electrical test equipment on any circuit related to the SRS unless instructed to in this Service Manual. SRS wiring harnesses can be identified by yellow and/or orange harnesses or harness connectors.

PRECAUTIONS WHEN USING POWER TOOLS (AIR OR ELECTRIC) AND HAMMERS

WARNING:

Always observe the following items for preventing accidental activation.

- When working near the Air Bag Diagnosis Sensor Unit or other Air Bag System sensors with the ignition ON or engine running, never use air or electric power tools or strike near the sensor(s) with a hammer. Heavy vibration could activate the sensor(s) and deploy the air bag(s), possibly causing serious injury.
- When using air or electric power tools or hammers, always switch the ignition OFF, disconnect the battery, and wait at least 3 minutes before performing any service.

Precautions for Removing Battery Terminal

INFOID:000000010763719

- When removing the 12V battery terminal, turn OFF the ignition switch and wait at least 30 seconds.

NOTE:

ECU may be active for several tens of seconds after the ignition switch is turned OFF. If the battery terminal is removed before ECU stops, then a DTC detection error or ECU data corruption may occur.

- For vehicles with the 2-batteries, be sure to connect the main battery and the sub battery before turning ON the ignition switch.

NOTE:

If the ignition switch is turned ON with any one of the terminals of main battery and sub battery disconnected, then DTC may be detected.

- After installing the 12V battery, always check "Self Diagnosis Result" of all ECUs and erase DTC.

NOTE:

The removal of 12V battery may cause a DTC detection error.

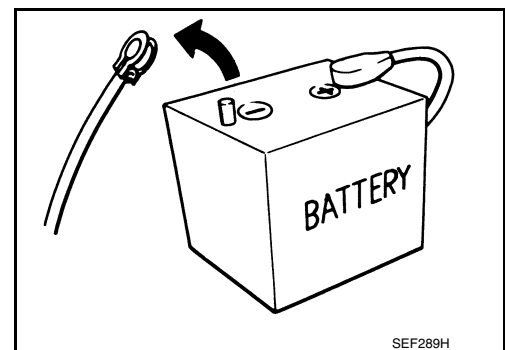

Service Notice

INFOID:000000010584584

- When removing or installing various parts, place a cloth or padding onto the vehicle body to prevent scratches.
- Handle trim, molding, instruments, grille, etc. carefully during removing or installing. Be careful not to oil or damage them.

PRECAUTIONS

< PRECAUTION >

- Apply sealing compound where necessary when installing parts.
- When applying sealing compound, be careful that the sealing compound does not protrude from parts.
- When replacing any metal parts (for example body outer panel, members, etc.), be sure to take rust prevention measures.

Precaution for Work

INFOID:000000010584585

- When removing or disassembling each component, be careful not to damage or deform it. If a component may be subject to interference, be sure to protect it with a shop cloth.
- When removing (disengaging) components with a screwdriver or similar tool, be sure to wrap the component with a shop cloth or vinyl tape to protect it.
- Protect the removed parts with a shop cloth and keep them.
- Replace a deformed or damaged clip.
- If a part is specified as a non-reusable part, always replace it with new one.
- Be sure to tighten bolts and nuts securely to the specified torque.
- After re-installation is completed, be sure to check that each part works normally.
- Follow the steps below to clean components.
- Water soluble foul: Dip a soft cloth into lukewarm water, and wring the water out of the cloth to wipe the fouled area.
Then rub with a soft and dry cloth.
- Oily foul: Dip a soft cloth into lukewarm water with mild detergent (concentration: within 2 to 3%), and wipe the fouled area.
Then dip a cloth into fresh water, and wring the water out of the cloth to wipe the detergent off. Then rub with a soft and dry cloth.
- Never use organic solvent such as thinner, benzene, alcohol, and gasoline.
- For genuine leather seats, use a genuine leather seat cleaner.

A

B

C

D

E

F

G

H

I

SE

K

L

M

N

O

P

PREPARATION

< PREPARATION >

PREPARATION

PREPARATION

Special Service Tool

INFOID:000000010584586

The actual shapes of Kent-Moore tools may differ from those of special service tools illustrated here.

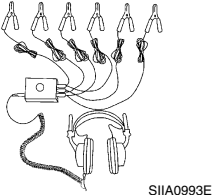
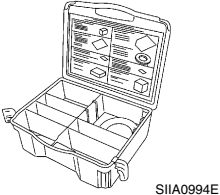
Tool number (Kent-Moore No.) Tool name	Description
<p>(J39570) Chassis ear</p>  <p>SIIA0993E</p>	<p>Locates the noise</p>
<p>(J-50397) NISSAN Squeak and Rattle Kit</p>  <p>SIIA0994E</p>	<p>Repairs the cause of noise</p>

Commercial Service Tool

INFOID:000000010584587

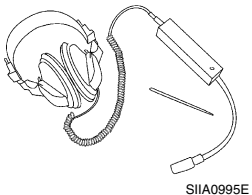
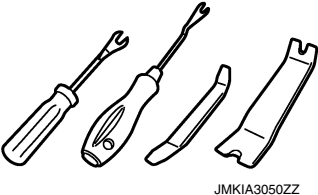
Tool name	Description
<p>Engine ear</p>  <p>SIIA0995E</p>	<p>Locates the noise</p>
<p>Remover tool</p>  <p>JMKIA3050ZZ</p>	<p>Removes clips, pawls and metal clips</p>

CLIP LIST

< PREPARATION >

CLIP LIST

Clip List

INFOID:000000010584588

Shapes	Removal & Installation	Shapes	Removal & Installation
	<p>Removal: Remove by bending up with flat-bladed screwdrivers or clip remover.</p>		<p>Removal:</p>
	<p>Removal: Remove with a clip remover.</p>		<p>Removal:</p>
<p>Removal: Push center pin to catching position. (Do not remove center pin by hitting it.)</p> <p>Installation:</p>		<p>Removal: Holder portion of clip must be spread out to remove rod.</p>	
	<p>Removal: Remove by bending up with flat-bladed screwdrivers or clip remover.</p> <p>Clip Finisher</p>		<p>Removal:</p> <ol style="list-style-type: none"> Screw out with a Phillips screwdriver. Remove female portion with flat-bladed screwdriver.
	<p>Removal:</p>		<p>Removal:</p> <p>Rotate 45° to remove.</p> <p>Installation:</p>
	<p>Removal:</p>		<p>Removal:</p>

JMJIA3734GB

A
B
C
D
E
F
G
H
I
SE
K
L
M
N
O
P

FRONT SEAT

< REMOVAL AND INSTALLATION >

REMOVAL AND INSTALLATION

FRONT SEAT

Exploded View

INFOID:000000010584589

DRIVER SEAT

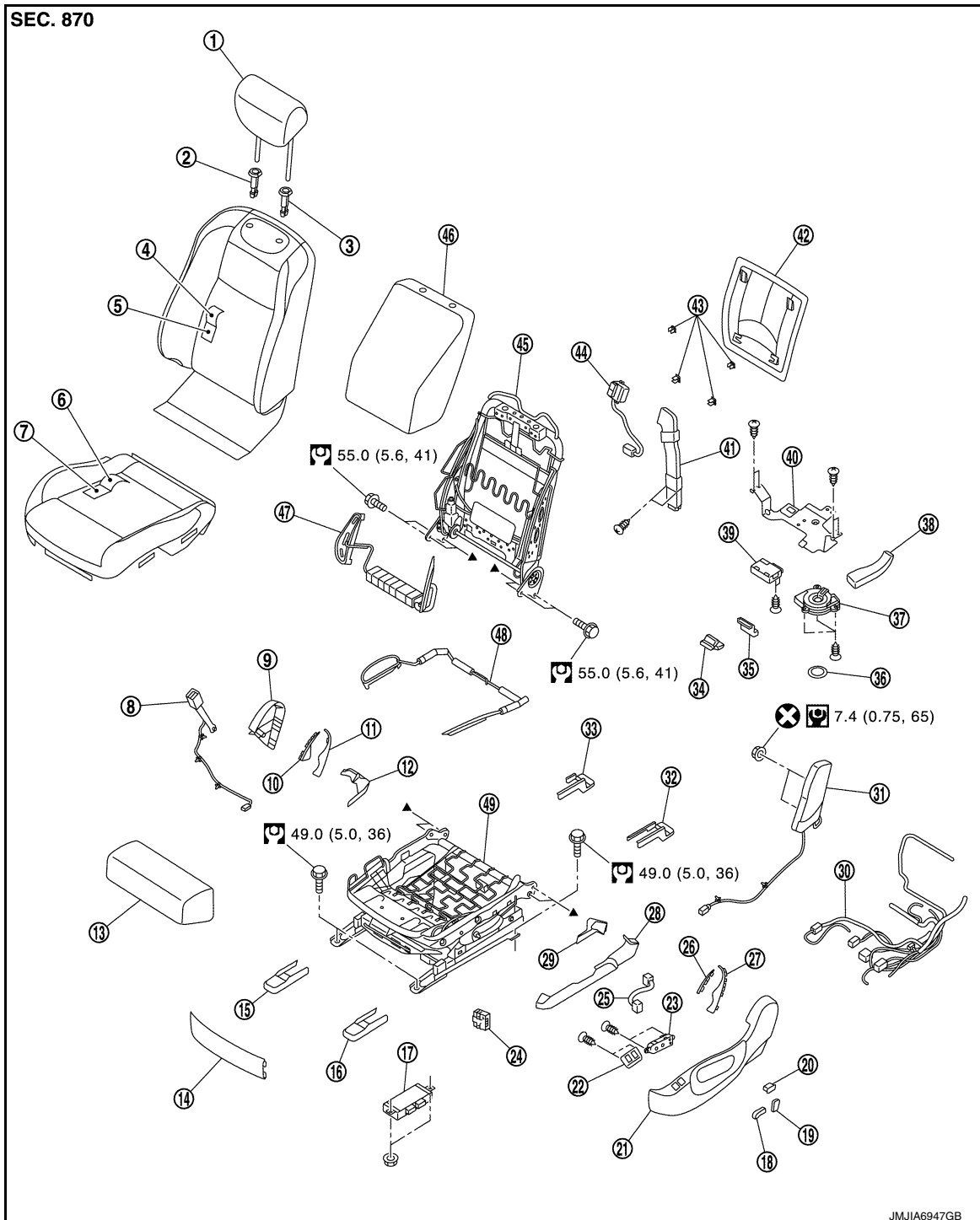



- | | | |
|---------------------|---------------------------|--|
| 1. Headrest | 2. Headrest holder (free) | 3. Headrest holder (locked) |
| 4. Seatback trim | 5. Seatback pad | 6. Seat cushion trim |
| 7. Seat cushion pad | 8. Seat belt buckle | 9. Seat cushion inner finisher outside |

FRONT SEAT

< REMOVAL AND INSTALLATION >

- | | | | |
|---|--|---|---|
| 10. Seat cushion inner finisher inside (front) | 11. Seat cushion inner finisher inside (rear) | 12. Seat cushion inner lower finisher | |
| 13. Seat cushion pad (front) | 14. Seat cushion front finisher | 15. Front inner slide cover | A |
| 16. Front outer slide cover | 17. Seat control unit | 18. Seat slide and lifter switch knob | |
| 19. Seat reclining switch knob | 20. Lumbar support switch | 21. Seat cushion outer finisher outside | B |
| 22. Slide support switch | 23. Seat control switch | 24. Heated seat control unit | |
| 25. Seat switch harness | 26. Seat cushion outer finisher inside (front) | 27. Seat cushion outer finisher inside (rear) | C |
| 28. Seat cushion outer lower finisher (outside) | 29. Seat cushion outer lower finisher (inside) | 30. Seat harness | |
| 31. Side air bag module | 32. Rear outer slide cover | 33. Rear inner slide cover | D |
| 34. Seat cushion thermal electric device | 35. Seat cushion duct A | 36. Blower filter | |
| 37. Climate controlled seat blower motor | 38. Seat cushion duct B | 39. Climate controlled seat control unit | E |
| 40. Climate unit bracket | 41. Seatback duct | 42. Seatback board | |
| 43. Clip | 44. Seatback thermal electric device | 45. Seatback frame | F |
| 46. Seatback silencer | 47. Seatback side support bag and unit | 48. Seat cushion side support bag | |
| 49. Seat cushion frame | | | G |

 : Always replace after every disassembly.

 : N·m (kg-m, ft-lb)

 : N·m (kg-m, in-lb)

 : Indicates that the part is connected at points with same symbol in actual vehicle

PASSENGER SEAT

SE

K

L

M

N

O

P

FRONT SEAT

< REMOVAL AND INSTALLATION >

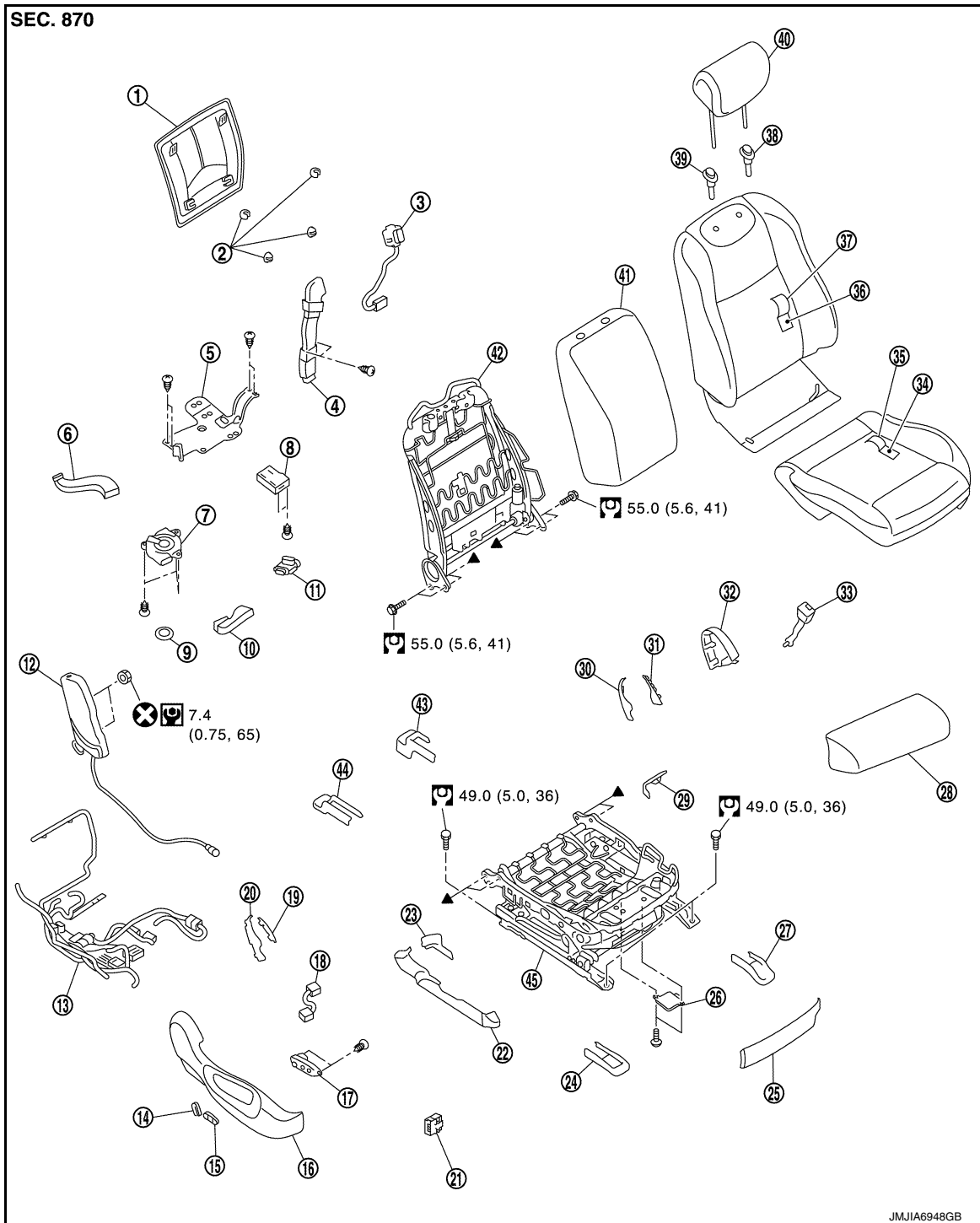



- | | | |
|---|--|---------------------------------------|
| 1. Seatback board | 2. Clip | 3. Seatback thermal electric device |
| 4. Seatback duct | 5. Climate unit bracket | 6. Seat cushion duct B |
| 7. Climate controlled seat blower motor | 8. Climate controlled seat control unit | 9. Blower filter |
| 10. Seat cushion duct A | 11. Seat cushion thermal electric device | 12. Side air bag module |
| 13. Seat harness | 14. Seat reclining switch knob | 15. Seat slide and lifter switch knob |
| 16. Seat cushion outer finisher outside | 17. Seat control switch | 18. Seat switch harness |
| 19. Seat cushion outer finisher inside (front) | 20. Seat cushion outer finisher inside (rear) | 21. Heated seat control unit |
| 22. Seat cushion outer lower finisher (outside) | 23. Seat cushion outer lower finisher (inside) | 24. Front outer slide cover |

FRONT SEAT

< REMOVAL AND INSTALLATION >

- | | | |
|--|--|---|
| 25. Seat cushion front finisher | 26. Occupant detection system control unit | 27. Front inner slide cover |
| 28. Seat cushion pad (front) | 29. Seat cushion inner lower finisher | 30. Seat cushion inner finisher inside (rear) |
| 31. Seat cushion inner finisher inside (front) | 32. Seat cushion inner finisher outside | 33. Seat belt buckle |
| 34. Seat cushion pad | 35. Seat cushion trim | 36. Seatback pad |
| 37. Seatback trim | 38. Headrest holder (locked) | 39. Headrest holder (free) |
| 40. Headrest | 41. Seatback silencer | 42. Seatback frame |
| 43. Rear inner slide cover | 44. Rear outer slide cover | 45. Seat cushion frame |

 : Always replace after every disassembly.

 : N·m (kg-m, ft-lb)

 : N·m (kg-m, in-lb)

 : Indicates that the part is connected at points with same symbol in actual vehicle

Removal and Installation

INFOID:000000010584590

REMOVAL

CAUTION:

When removing and installing, use shop cloths to protect parts from damage.

1. Remove the headrest.
2. Remove the front outer slide cover.
 - a. Slide the seat to the rear-most position.
 - b. Pull up the front edge of the front outer slide cover to release the pawls.
 - c. Slide the front outer slide cover forward to release the pawls.

 : Pawl

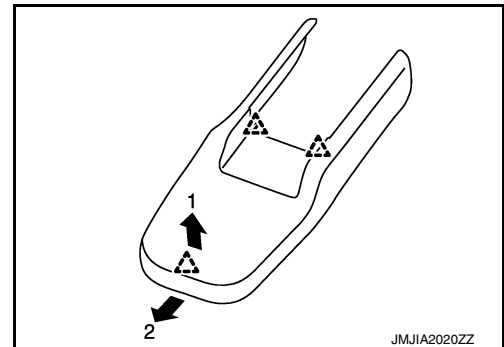

3. Remove the front inner slide cover.
 - a. Slide the seat to the rear-most position.
 - b. Pull up the front edge of the front inner slide cover to release the pawls.
 - c. Slide the front inner slide cover forward to release the pawls.

 : Pawl

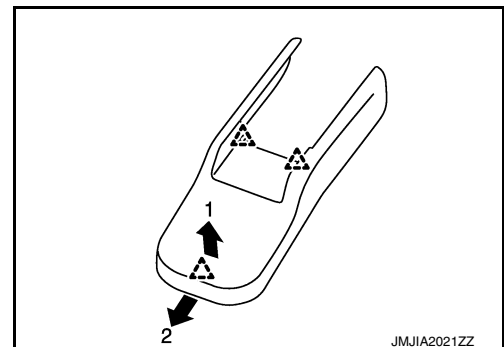

4. Remove the mounting bolts on the front side of the front seat.
5. Remove the rear outer slide cover.

A
B
C
D
E
F
G
H
I
SE
K
L
M
N
O
P

FRONT SEAT

< REMOVAL AND INSTALLATION >

- a. Slide the seat to the front-most position.
- b. Pull up the rear edge of the rear outer slide cover to release the pawls.
- c. Slide the rear outer slide cover to release the pawls.

 : Pawl

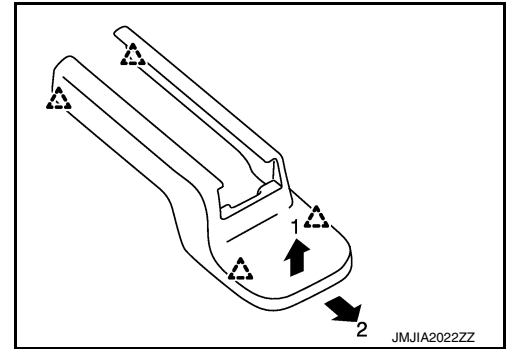

6. Remove the rear inner slide cover.
 - a. Slide the seat to the front-most position.
 - b. Pull up the rear edge of the rear inner slide cover to release the pawls.
 - c. Slide the rear inner slide cover rearward to release the pawls.

 : Pawl

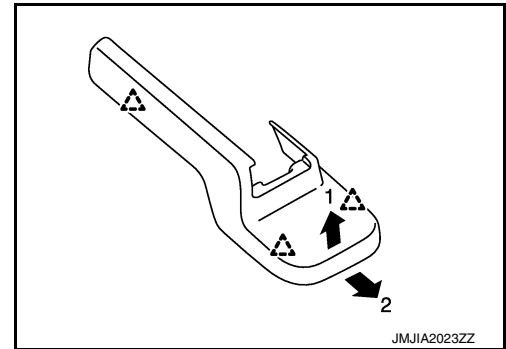

7. Remove the mounting bolts on the rear side of the front seat.
8. Set seatback in a standing position.
9. Disconnect harness connector under the seat and remove harness securing clips.

CAUTION:

Before servicing, turn ignition switch OFF, disconnect battery negative terminal and wait for 3 minutes or more.

10. Remove seat from the vehicle.

CAUTION:

- When removing and installing, use shop cloths to protect parts from damage.
- When removing and installing, 2 workers are required so as to prevent it from dropping.

INSTALLATION

Note the following items, and then install in the reverse order of removal.

CAUTION:

- Before servicing, turn ignition switch OFF, disconnect battery negative terminal and wait for 3 minutes or more.
- Clamp the harness in position.

NOTE:

- After installing the front seat, perform additional service when removing battery negative terminal (automatic drive positioner model only). Refer to [ADP-8, "ADDITIONAL SERVICE WHEN REMOVING BATTERY NEGATIVE TERMINAL : Special Repair Requirement"](#).
- After installing the passenger seat, perform zero point reset. Refer to [SRC-6, "ZERO POINT RESET : Special Repair Requirement"](#).

Disassembly and Assembly

INFOID:000000010584591

SEATBACK

Disassembly

1. Remove the seatback board.

FRONT SEAT

< REMOVAL AND INSTALLATION >

- a. Remove the clips, and then pull out seatback board.
- b. Pull down the seatback board to release the upper pawls.

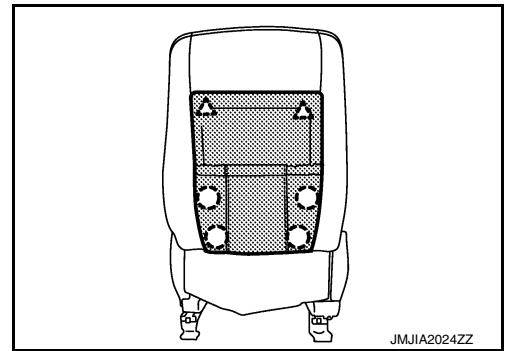
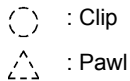

2. Remove the seat cushion outer finisher.
- a. Remove the clip, metal clips and pawls, and then pull out seat cushion outer finisher.

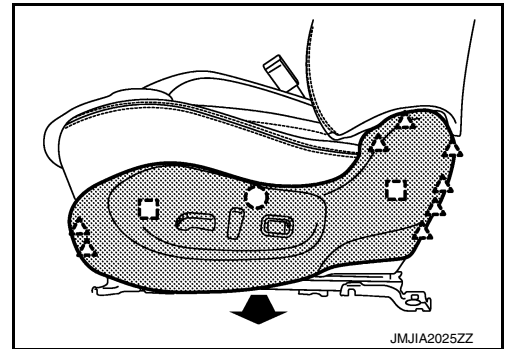
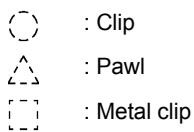

- b. Remove the connector clamps, and then disconnect harness connectors.
3. Remove the seat cushion outer finisher inside (front and rear).
4. Remove the seat cushion inner finisher. Remove the metal clip and pawls, and then pull out seat cushion inner finisher.

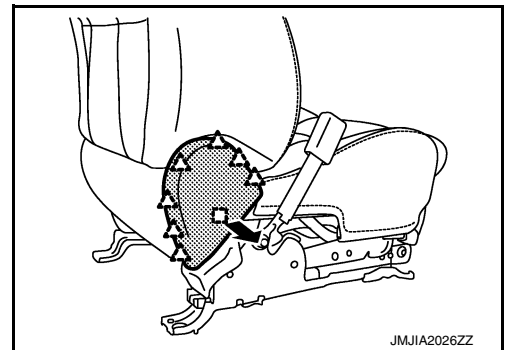
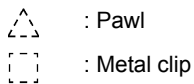

5. Remove the seat cushion inner finisher inside (front and rear).
6. Remove the seatback trim retainer and seatback trim band from seat cushion frame.
7. Disconnect the seatback heater unit harness connector (A).

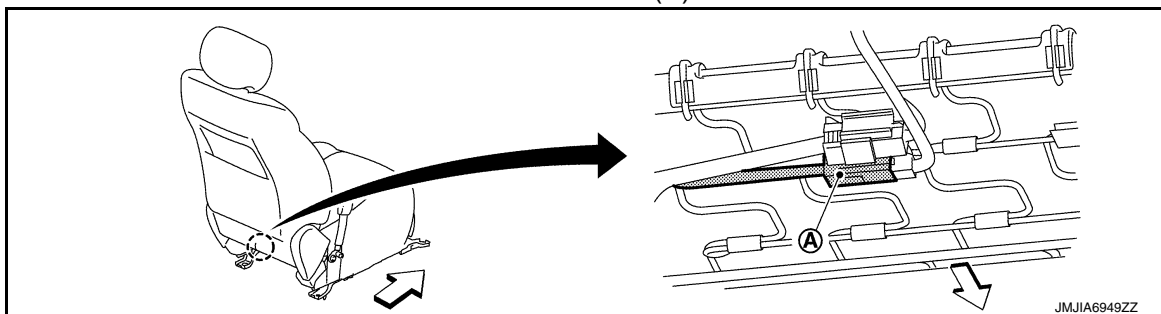

8. Remove the seatback assembly.

A
B
C
D
E
F
G
H
I
SE
K
L
M
N
O
P

FRONT SEAT

< REMOVAL AND INSTALLATION >

- a. Remove the side air bag module harness (A).

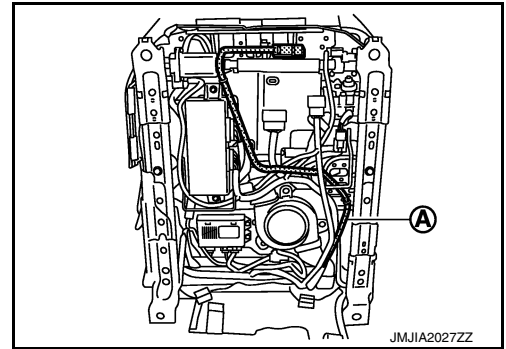

- b. Cut the seatback duct band (1) of seat cushion under side.
c. Disconnect the side support air hose joint (2).

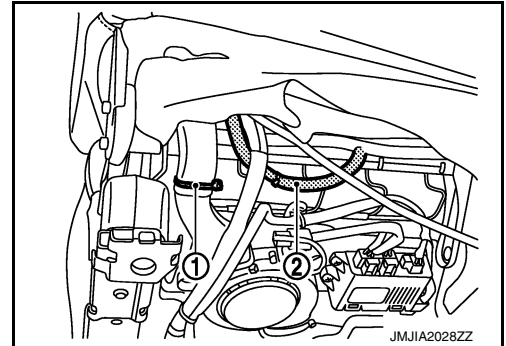

- d. Disconnect the reclining motor harness connector (B).
e. Disconnect the lumbar support unit harness connector (C).
f. Disconnect the side support unit harness connector (D).
g. Disconnect the seatback thermal electric device harness connector (E).

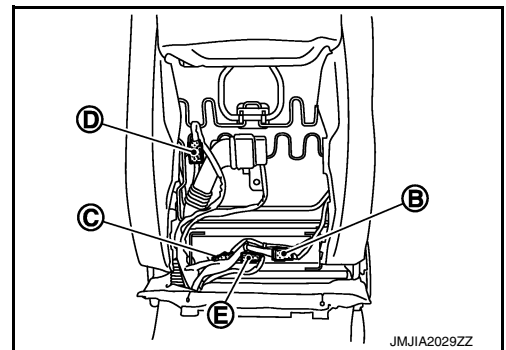

- h. Pull out harness from the seatback trim and seat cushion trim.
i. Remove the seatback assembly mounting bolts (F).

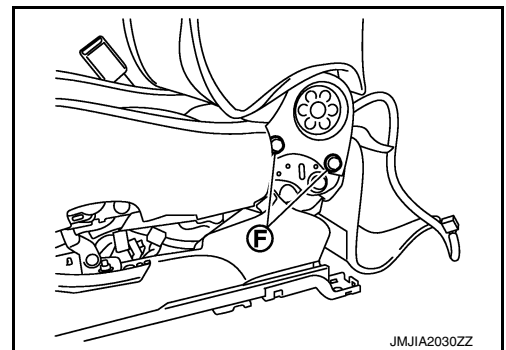

9. Remove the seatback trim and seatback pad.

FRONT SEAT

< REMOVAL AND INSTALLATION >

- a. Remove the headrest holder.

CAUTION:

**Before installing headrest holder check its orientation.
(front/rear and right/left)**

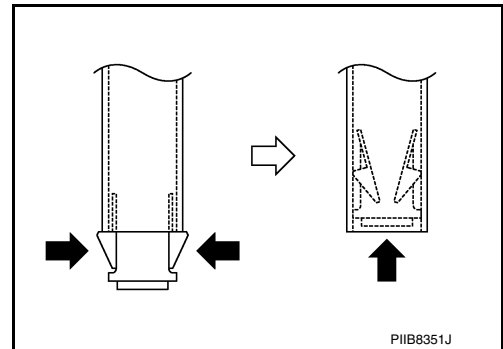

- b. Remove the side air bag module mounting nuts (A).

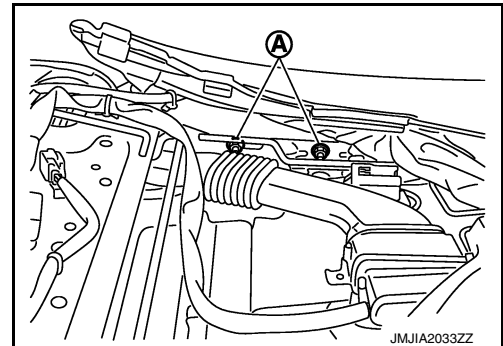

- c. Remove the seatback trim and seatback pad from the seatback frame.

- d. Remove the side air bag module.

- e. Remove the hog rings, and separate the seatback trim and seatback pad.

10. Remove the seatback silencer.

11. Remove the seatback side support bag and unit. (Side support model only.)

- a. Remove the pawls, and then remove side support bag (1).

- b. Remove the side support unit (2).

 : Pawl

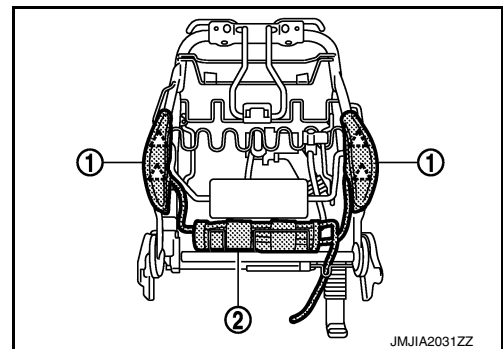

Assembly

Note the following item, and assemble in the reverse order of disassembly.

CAUTION:

Install the hog rings of seatback trim in position, and then securely connect the trim or trim cord with the pad side wire.

SEAT CUSHION

Disassembly

1. Remove the seatback board.

FRONT SEAT

< REMOVAL AND INSTALLATION >

- a. Remove the clips, and then pull out seatback board.
- b. Pull down the seatback board to release the upper pawls.

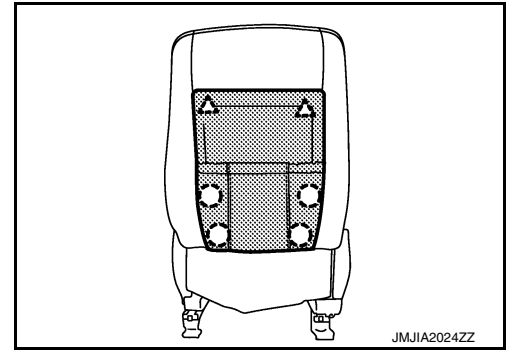
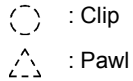

2. Remove the seat cushion front finisher.
 Remove the metal clips and pawls, pull out seat cushion front finisher.

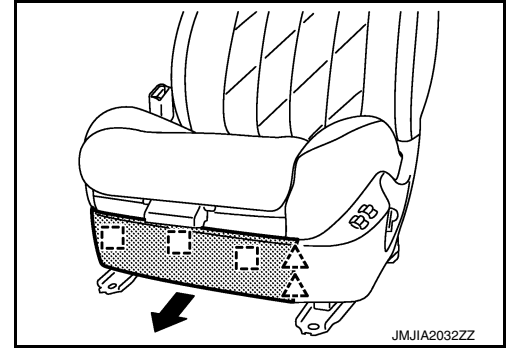
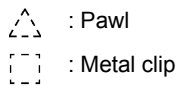

3. Remove the seat cushion outer finisher.
 a. Remove the clip, metal clips and pawls, and then pull out seat cushion outer finisher.

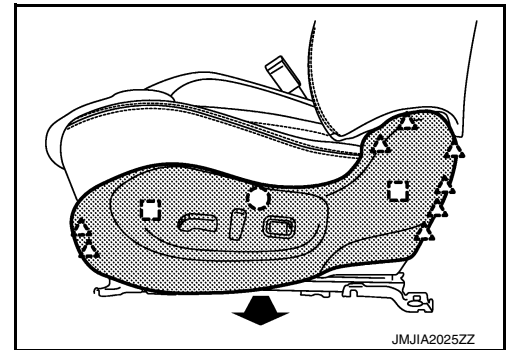
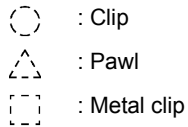

- b. Remove the connector clamps, and then disconnect harness connectors.
4. Remove the seat cushion outer finisher inside (front and rear).
5. Remove the seat cushion inner finisher.
 Remove the metal clip and pawls, and then pull out seat cushion inner finisher.

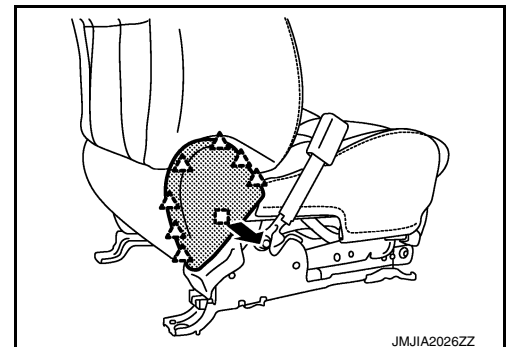
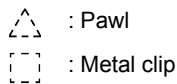

6. Remove the seat cushion inner finisher inside (front and rear).
7. Remove the seatback trim retainer and seatback trim band from seat cushion frame.

FRONT SEAT

< REMOVAL AND INSTALLATION >

8. Disconnect the seatback heater unit harness connector (A).

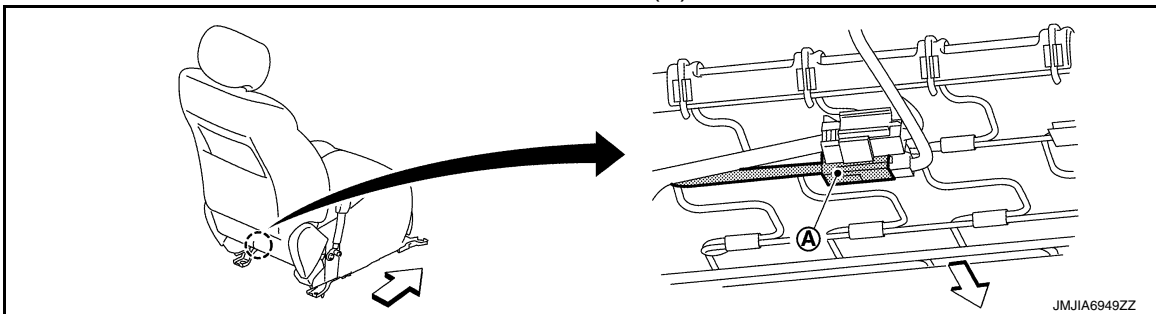

↶ : Vehicle front

9. Remove the seatback assembly.
a. Remove the side air bag module harness (A).

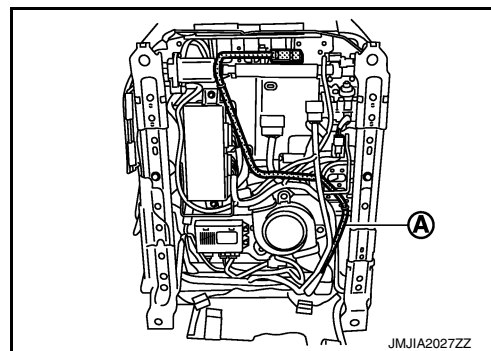

- b. Cut the seatback duct band (1) of seat cushion under side.
c. Disconnect the side support air hose joint (2).

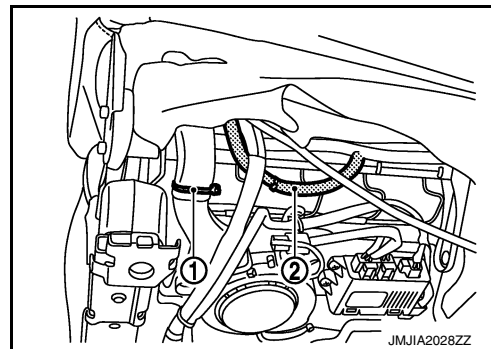

- d. Disconnect the reclining motor harness connector (B).
e. Disconnect the lumbar support unit harness connector (C).
f. Disconnect the side support unit harness connector (D).
g. Disconnect the thermal electric device harness connector (E).

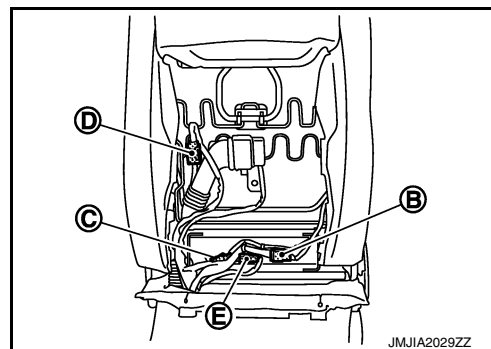

- h. Pull out harness from the seatback trim and seat cushion trim.

A
B
C
D
E
F
G
H
I
SE
K
L
M
N
O
P

FRONT SEAT

< REMOVAL AND INSTALLATION >

- i. Remove the seatback assembly mounting bolts (F).

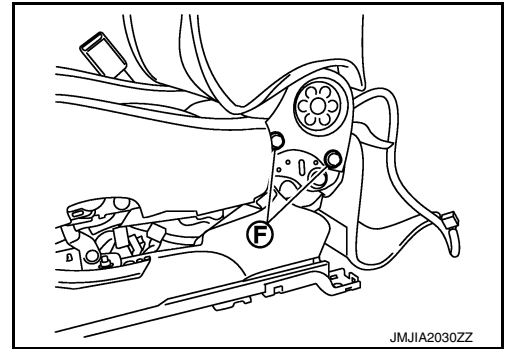

10. Remove the seat belt buckle. Refer to [SB-8. "SEAT BELT BUCKLE : Removal and Installation"](#).

11. Remove the seat cushion pad (front). (Thigh extension model only.)

- a. Remove the retainer.
- b. Remove the seat cushion pad (front).

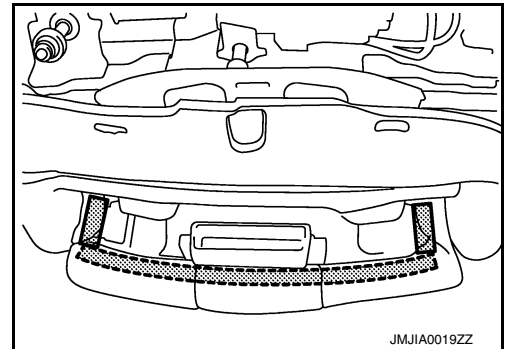

12. Remove the seat cushion trim and seat cushion pad.

- a. Remove the seat cushion trim wire (1) from the hooks (2). (Thigh extension model only.)

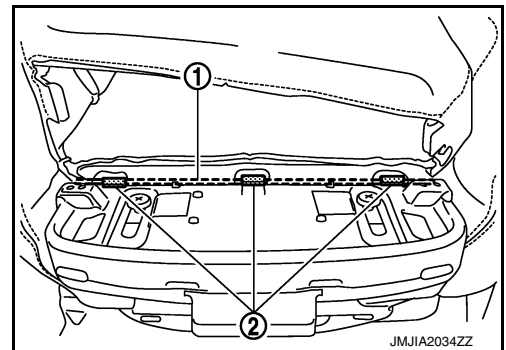

- b. Remove the clips (A). (Thigh extension model only.)

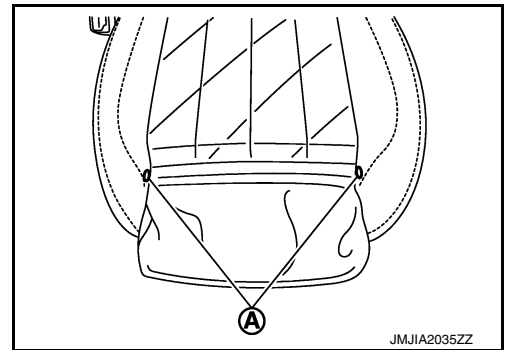

- c. Remove the seat cushion retainer.

FRONT SEAT

< REMOVAL AND INSTALLATION >

d. Disconnect the seat cushion heater unit harness connector (A).

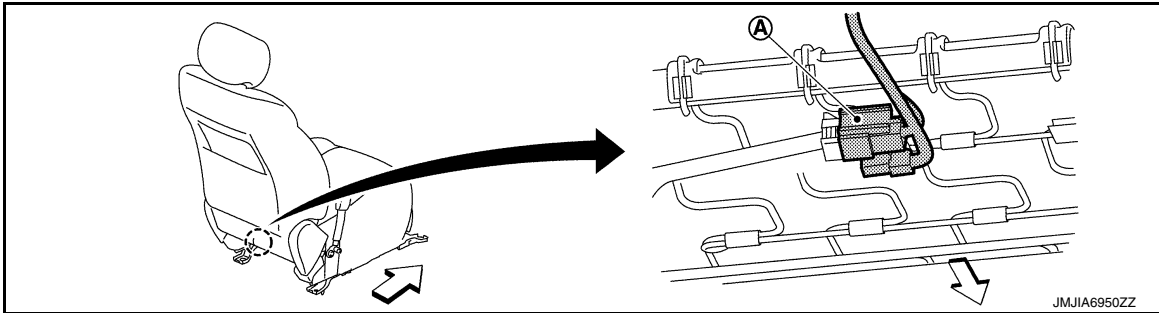

↔ : Vehicle front

e. Remove the hog rings, and separate the seat cushion trim and seat cushion pad.

13. Remove the seat cushion side support bag. (Side support model only.)

a. Remove the hose clamp.

b. Remove the pawls, and then remove side support bag (1).

△ : Pawl

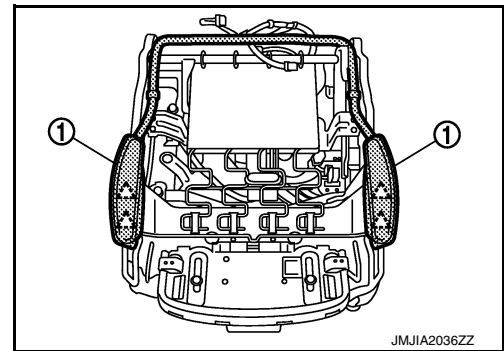

14. Remove the metal clips and pawl, and then pull out seat cushion outer lower finisher outside (1) and inside (2).

△ : Pawl
□ : Metal clip

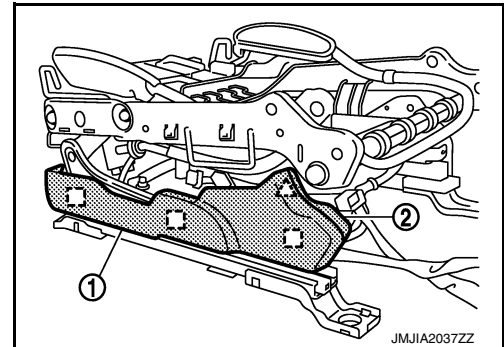

15. Remove the seat cushion inner lower finisher.

□ : Metal clip

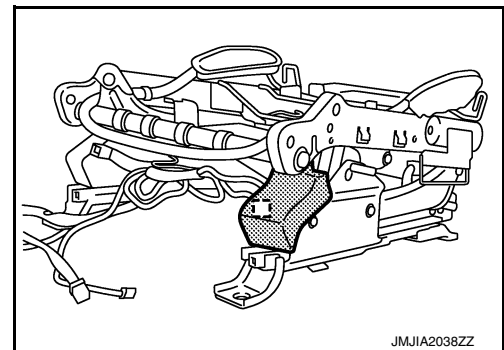

16. Remove the driver seat control unit (Automatic drive positioner model only). Refer to [ADP-216, "Removal and Installation"](#).

17. Remove the occupant detection system control unit. Refer to [SR-28, "Removal and Installation"](#).

18. Remove the heated seat control unit. Refer to [SE-150, "Removal and Installation"](#).

Assembly

A
B
C
D
E
F
G
H
I
SE
K
L
M
N
O
P

FRONT SEAT

< REMOVAL AND INSTALLATION >

Note the following item, and assemble in the reverse order of disassembly.

CAUTION:

Install the hog rings of seat cushion trim in position, and then securely connect the trim or trim cord with the pad side wire.

CLIMATE CONTROLLED SEAT UNIT

Disassembly

1. Remove the seatback duct and seatback thermal electric device.
Remove the screws (A), and then cut the band (1).

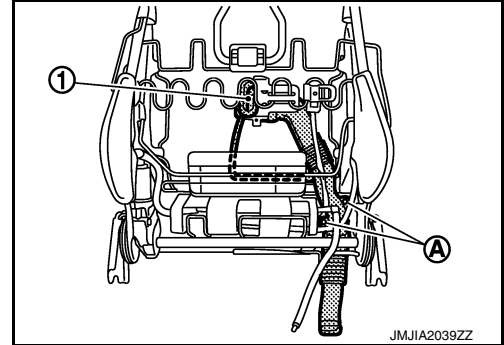

2. Remove the climate controlled seat control unit.
 - a. Disconnect the harness connectors (A).
 - b. Remove the climate controlled seat control unit fixing screws (B).

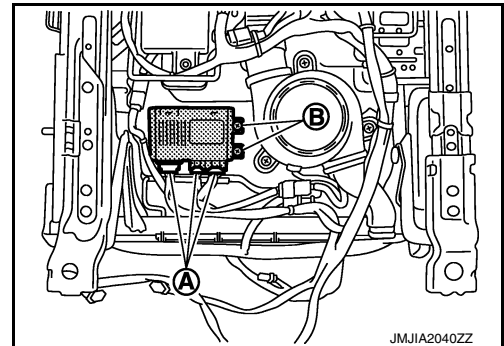

3. Remove the seat cushion duct, seat cushion thermal electric device and climate controlled seat blower motor.
 - a. Disconnect the harness connectors (A).
 - b. Remove the thermal electric device fixing screw (B).
 - c. Remove the climate controlled seat blower motor fixing screws (C).

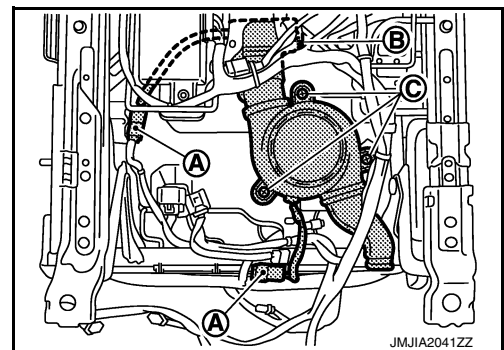

Assembly

Assemble in the reverse order of disassembly.

REAR SEAT

< REMOVAL AND INSTALLATION >

REAR SEAT

Exploded View

INFOID:000000010584592

SEC. 880

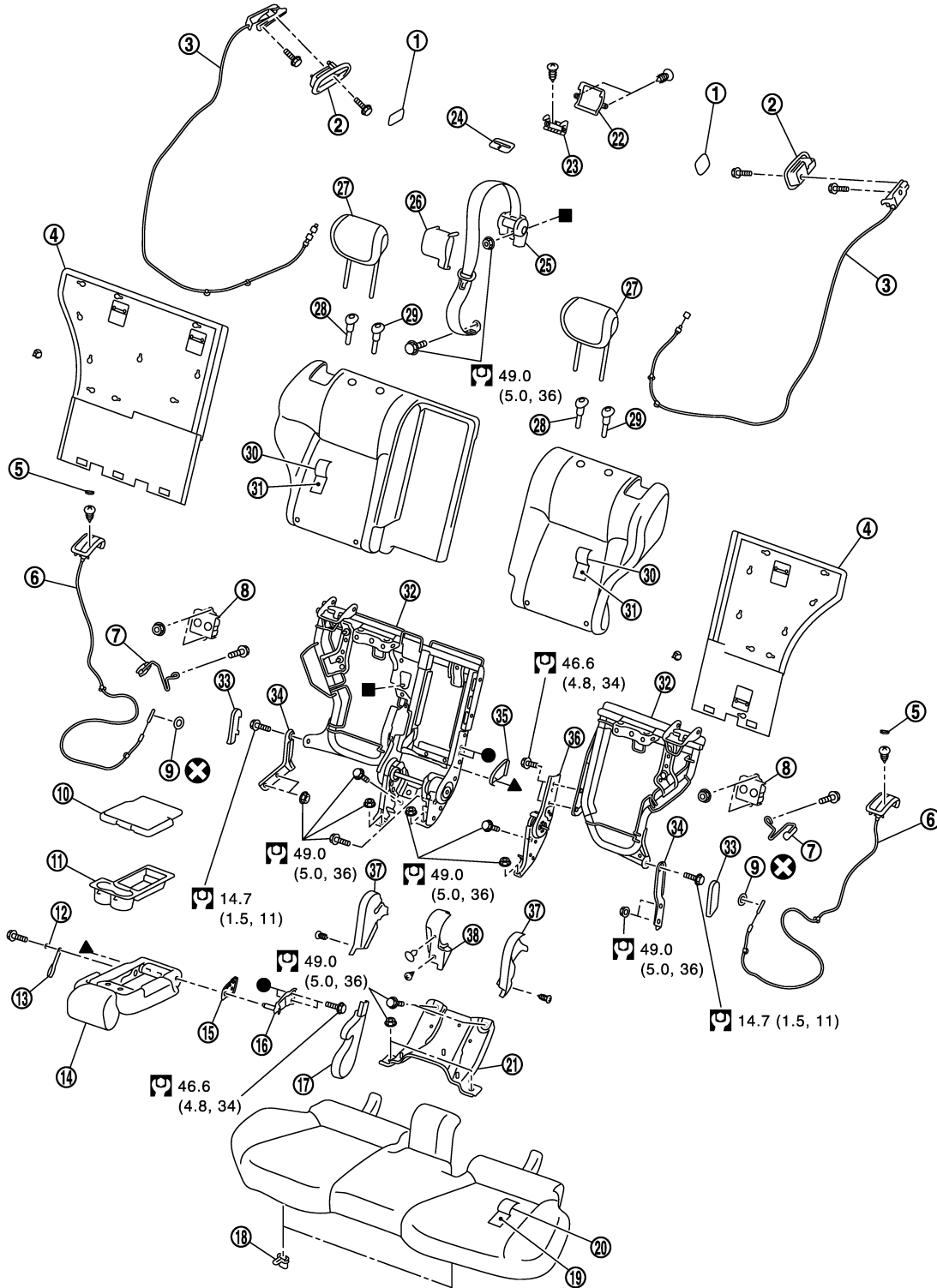

A
B
C
D
E
F
G
H
I
SE
K
L
M
N
O
P

- | | | |
|--|------------------------------------|----------------------------------|
| 1. Seatback control cable finisher cap | 2. Seatback control cable finisher | 3. Seatback control cable |
| 4. Seatback board | 5. Reclining lever knob cap | 6. Reclining lever knob assembly |
| 7. Seat belt hook | 8. Dynamic damper | 9. Push nut |

REAR SEAT

< REMOVAL AND INSTALLATION >

- | | | |
|----------------------------------|---|--------------------------------|
| 10. Armrest lid assembly | 11. Cup holder | 12. Spacer |
| 13. Armrest strap | 14. Armrest pad and frame assembly | 15. Armrest hinge cover RH |
| 16. Armrest bracket | 17. Rear center device cover | 18. Seat cushion hook |
| 19. Seat cushion pad | 20. Seat cushion trim | 21. Rear center back bracket |
| 22. Seat belt guide (upper) | 23. Seat belt guide (lower) | 24. Seat belt finisher |
| 25. Center seat belt retractor | 26. Center seat belt retractor cover | 27. Headrest |
| 28. Headrest holder (free) | 29. Headrest holder (locked) | 30. Seatback trim |
| 31. Seatback pad | 32. Seatback frame | 33. Seatback hinge outer cover |
| 34. Seatback hinge | 35. Armrest hinge cover LH | 36. Reclining device LH |
| 37. Reclining device inner cover | 38. Reclining device inner cover inside | |

⊗ : Always replace after every disassembly.

Ⓜ : N·m (kg-m, ft-lb)

●, ▲, ■ : Indicates that the part is connected at points with same symbol in actual vehicle

Removal and Installation

INFOID:0000000010584593

REMOVAL

CAUTION:

- When removing and installing, use shop cloths to protect parts from damage.
- Always remove seat back while the reclining device is in the locked condition. Never release the locked condition after removing seat back.

1. Remove the seat cushion.
 - a. Pull the lock lever (1) at the front bottom of the seat cushion forward (1 for each side), and pull the seat cushion upward to release the wire (2) from the seat cushion hook. Then pull the seat cushion forward the remove
 - b. Remove the seat cushion from vehicle.

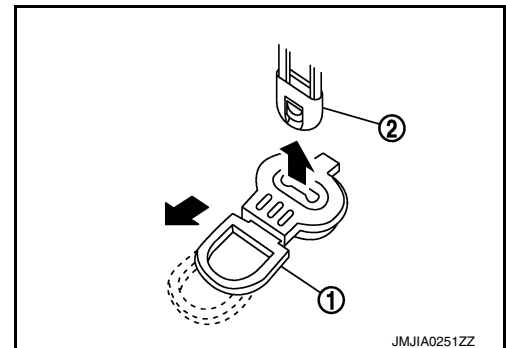

2. Remove the seatback RH.
 - a. Remove the rear seat belt inner anchor. Refer to [SB-11. "SEAT BELT RETRACTOR : Removal and Installation"](#).
 - b. Remove the LATCH system. Refer to [SB-17. "Removal and Installation"](#).
 - c. Remove the seatback control cable RH. Refer to [SE-143. "Removal and Installation"](#).
 - d. Remove the mounting nuts (A) and bolt (B).

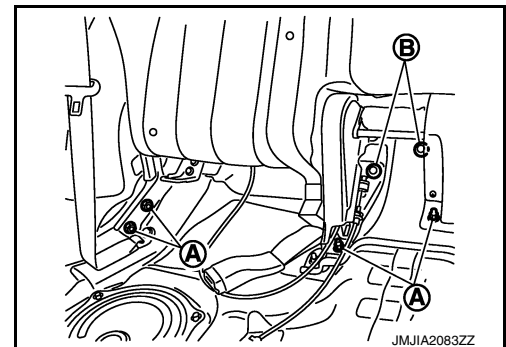

3. Remove the seatback LH.
 - a. Remove the LATCH system. Refer to [SB-17. "Removal and Installation"](#).
 - b. Remove the seatback control cable LH. Refer to [SE-143. "Removal and Installation"](#).

REAR SEAT

< REMOVAL AND INSTALLATION >

- c. Remove the mounting nuts (A) and bolt (B).

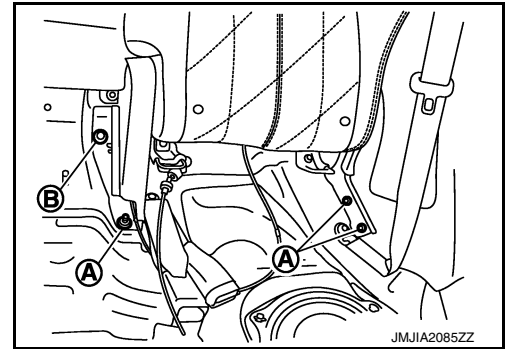

INSTALLATION

CAUTION:

- When removing and installing, use shop cloths to protect parts from damage.
- Always remove seat back while the reclining device is in the locked condition. Never release the locked condition after removing seat back.

1. Install the seatback LH mounting bolt (1) and nuts (2), (3), (4).

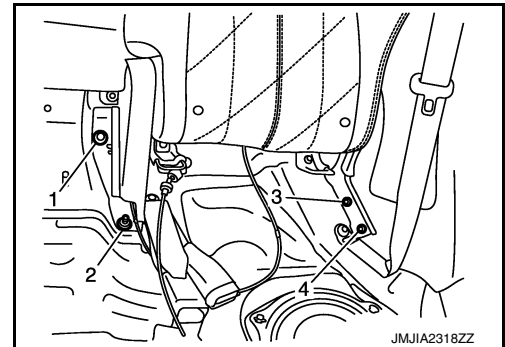

2. Install the seatback RH mounting bolts (1), (2) and nuts (3), (4) (5), (6).

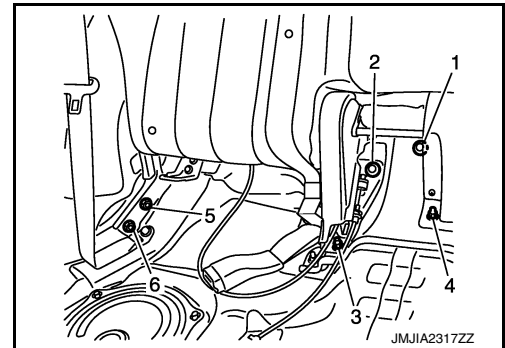

3. Install the seatback control cable. Refer to [SE-143, "Removal and Installation"](#).
4. Install the seat cushion.

Disassembly and Assembly

INFOID:0000000010584594

SEATBACK

Disassembly

1. Remove the seatback board.

REAR SEAT

< REMOVAL AND INSTALLATION >

Remove the clips.

 : Clip

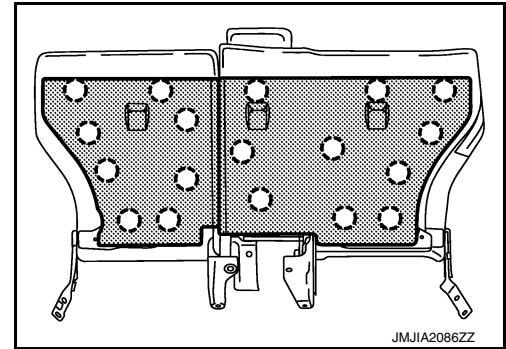

2. Remove the armrest assembly. (RH seat only)

a. Remove the hog rings, and then pull the seatback trim.

b. Remove the metal clips and pawl, and then pull out armrest bracket cover.

 : Pawl

 : Metal clip

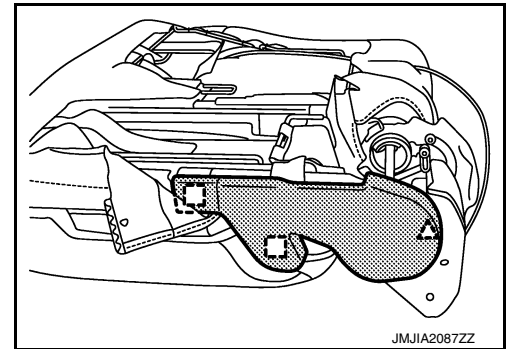

c. Remove the mounting bolts (A), and then remove the armrest bracket (1).

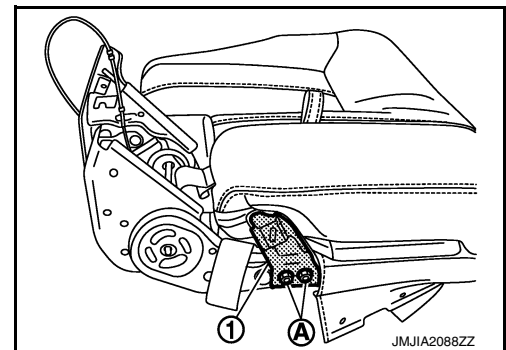

d. Remove the armrest assembly.

3. Remove the reclining device cover.

Remove the screws (A) and clip (B), and then reclining device inner cover (1) and reclining device inner cover inside (2).

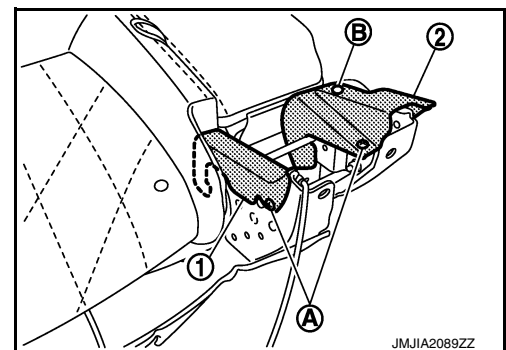

4. Remove the reclining lever knob assembly.

REAR SEAT

< REMOVAL AND INSTALLATION >

- a. Remove the push nut (1), cable resin part (2) and cable clamp (3).

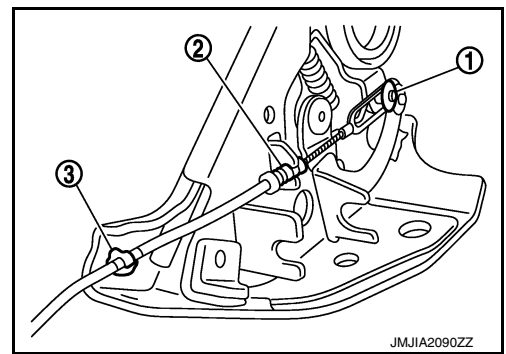

- b. Remove the hog rings (A) and cable clamp.

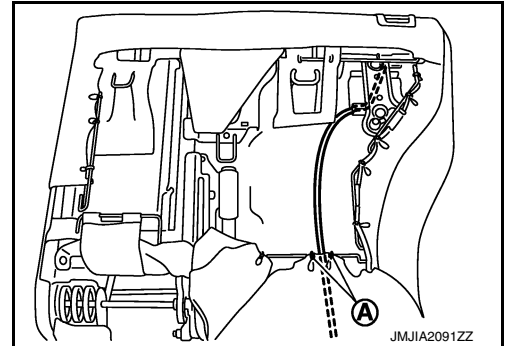

- c. Remove the reclining lever knob cap.
d. Remove the screw (B), and then remove reclining knob lever assembly (4).

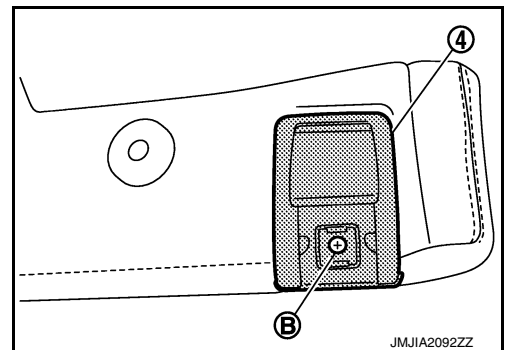

5. Remove the seatback trim and pad.
a. Remove the seatback hinge outer cover.
b. Remove the mounting bolt (A) and then remove seatback hinge.

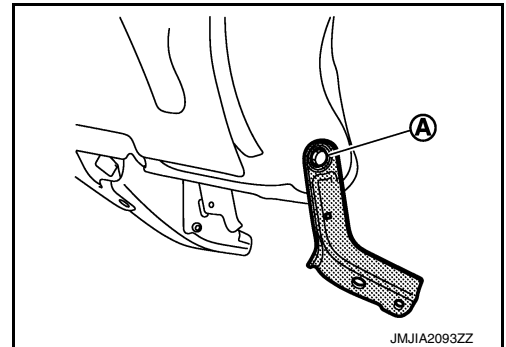

- c. Remove the hog rings from back side.
d. Remove the seatback retainer.
e. Remove the seat belt finisher. Refer to [SB-11. "SEAT BELT RETRACTOR : Removal and Installation"](#).

REAR SEAT

< REMOVAL AND INSTALLATION >

- f. Remove the headrest holder.

CAUTION:

Before installing headrest holder check its orientation.
(front/rear and right/left)

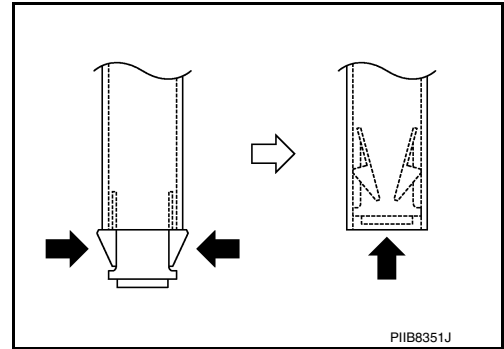

- g. Remove the seatback trim and pad.
h. Remove the hog rings to separate the seatback trim and seatback pad.
6. Remove the reclining device LH. (LH seat only)
Remove the mounting bolts (A), and then remove reclining device LH.

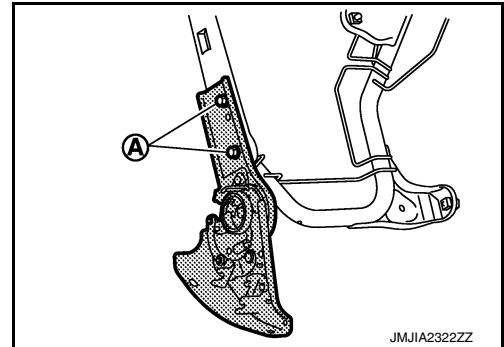

7. Remove the dynamic damper.
Remove the dynamic damper mounting nuts (A).

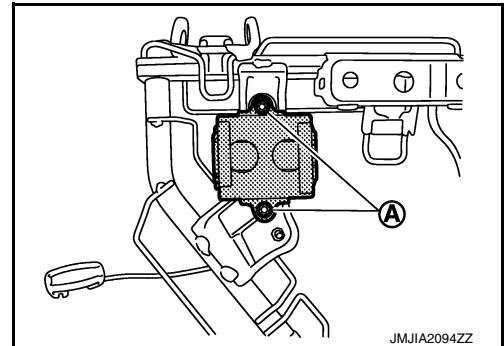

8. Remove the seat belt hook.
9. Remove the rear center seat belt retractor. Refer to [SB-11, "SEAT BELT RETRACTOR : Removal and Installation"](#).

Assembly

Assemble in the reverse order of disassembly.

CAUTION:

- Always slacken cable end and link pin when installing reclining lever knob cable.

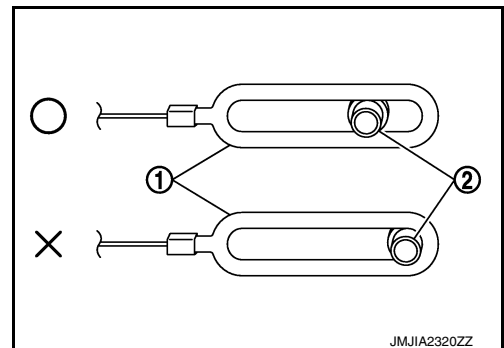

REAR SEAT

< REMOVAL AND INSTALLATION >

- Always install in the position that the reclining device lock can be released, because cable resin part is adjustable (3 stages).

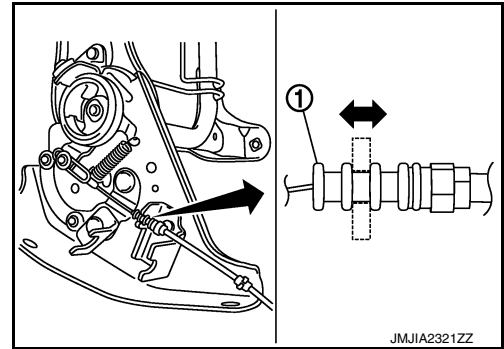

- Install the hog rings of seatback trim in position, and then securely connect the trim or trim cord with the seatback frame.

SEAT CUSHION

Disassembly

Remove the hog rings to separate the trim and pad.

Assembly

Assemble in the reverse order of disassembly.

CAUTION:

Install the hog rings of seat cushion trim in position, and then securely connect the trim or trim cord with the seat cushion pad wire.

ARMREST

Disassembly

1. Remove the cup holder.
Remove the metal clips and pawls.

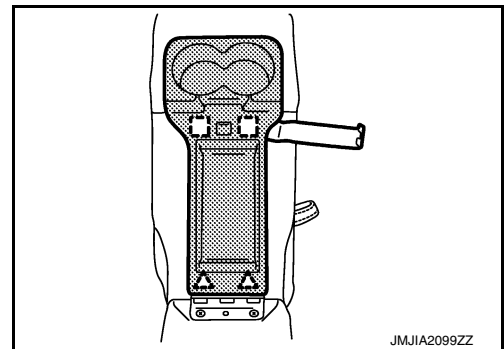
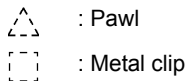

2. Remove the armrest lid assembly.
Remove the fixing screw.
3. Remove the armrest strap.
- a. Open the fastener (1), and then pull up armrest trim.

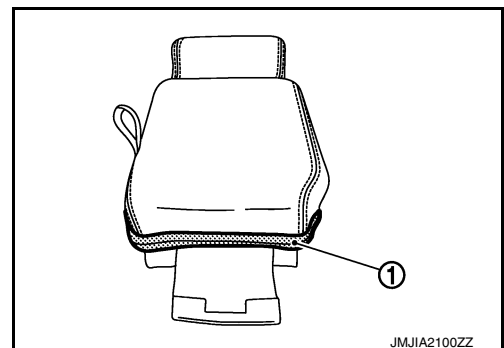

A
B
C
D
E
F
G
H
I
SE
K
L
M
N
O
P

REAR SEAT

< REMOVAL AND INSTALLATION >

- b. Remove the mounting bolt (A), and then remove armrest strap (2).

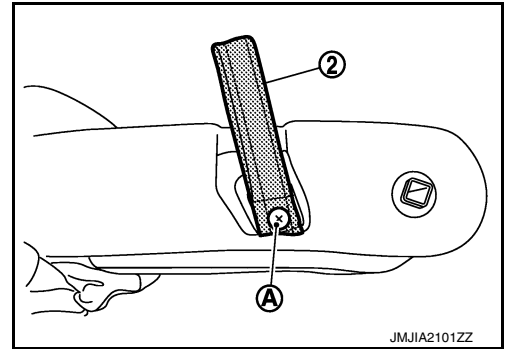

Assembly

Assemble in the reverse order of disassembly.

SEATBACK CONTROL CABLE

< REMOVAL AND INSTALLATION >

SEATBACK CONTROL CABLE

Exploded View

INFOID:000000010584595

Refer to [SE-135, "Exploded View"](#).

Removal and Installation

INFOID:000000010584596

REMOVAL

1. Remove the seat cushion assembly. Refer to [SE-136, "Removal and Installation"](#).
2. Remove the seatback control cable finisher. Refer to [INT-31, "Removal and Installation"](#).
3. Remove the luggage side finisher. Refer to [INT-31, "Removal and Installation"](#).
4. Remove the seatback control cable.
 - a. Remove the seatback control cable RH (1).

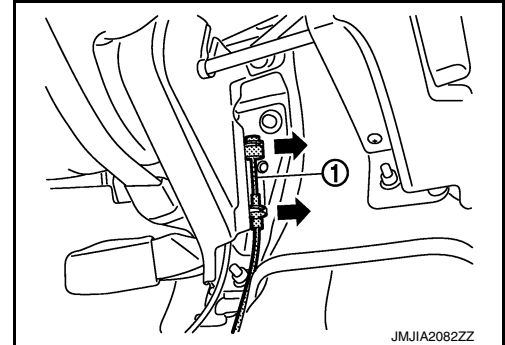

- b. Remove the seatback control cable LH (2).

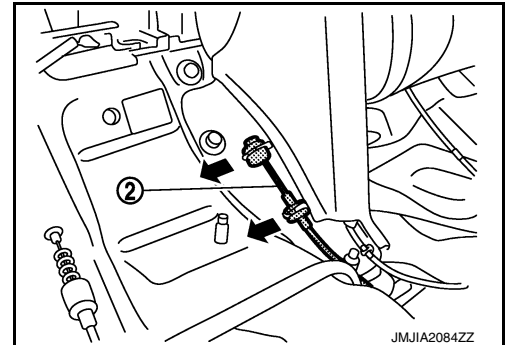

- c. Remove the mounting bolt (A).

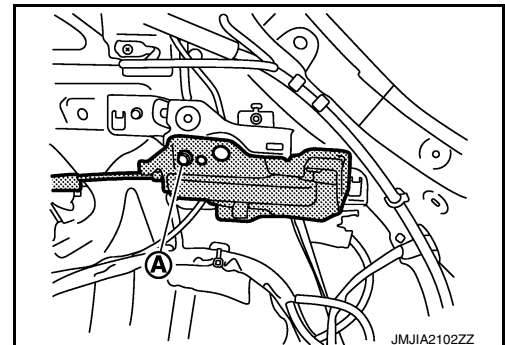

A
B
C
D
E
F
G
H
I
SE
K
L
M
N
O
P

SEATBACK CONTROL CABLE

< REMOVAL AND INSTALLATION >

- d. Remove the cable clamps (3), and then remove seatback control cable.

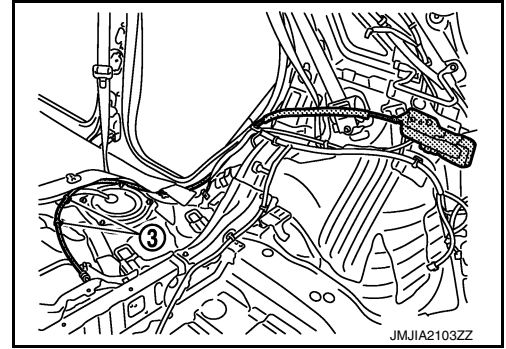

INSTALLATION

Install in the reverse order of removal.

CAUTION:

Always slacken cable end and cable clamp when installing seat back control cable.

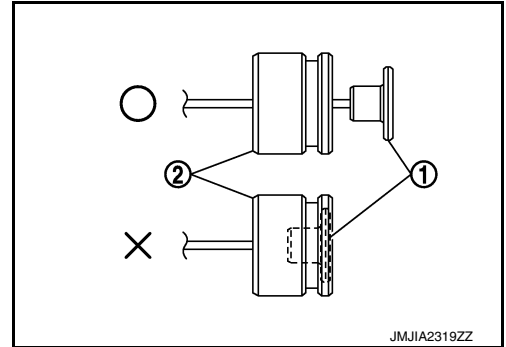

POWER SEAT SWITCH

< REMOVAL AND INSTALLATION >

POWER SEAT SWITCH

Exploded View

INFOID:000000010584597

Refer to [SE-122. "Exploded View"](#).

Removal and Installation

INFOID:000000010584598

REMOVAL

CAUTION:

When removing and installing, use shop cloths to protect parts from damage.

1. Remove the seat cushion outer finisher (1). Refer to [SE-125. "Removal and Installation"](#).
2. Remove the screws (A).
3. Remove the power seat switch (2) from the seat cushion outer finisher.

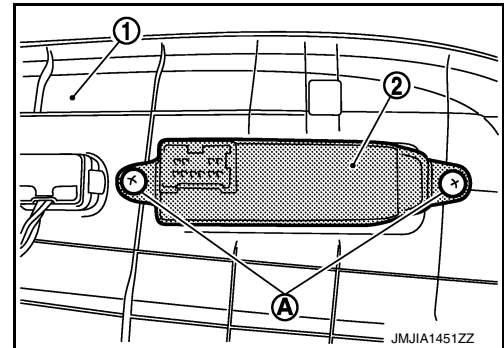

INSTALLATION

Install in the reverse order of removal.

CAUTION:

Be careful to clamp the harness to the right place.

A
B
C
D
E
F
G
H
I
K
L
M
N
O
P

SE

LUMBAR SUPPORT SWITCH

< REMOVAL AND INSTALLATION >

LUMBAR SUPPORT SWITCH

Exploded View

INFOID:000000010584599

Refer to [SE-122. "Exploded View"](#).

Removal and Installation

INFOID:000000010584600

REMOVAL

CAUTION:

When removing and installing, use shop cloths to protect parts from damage.

1. Remove the seat cushion outer finisher (1). Refer to [SE-125. "Removal and Installation"](#).
2. Remove the lumbar support switch (2) from the seat cushion outer finisher with remover tool (A).

 : Pawl

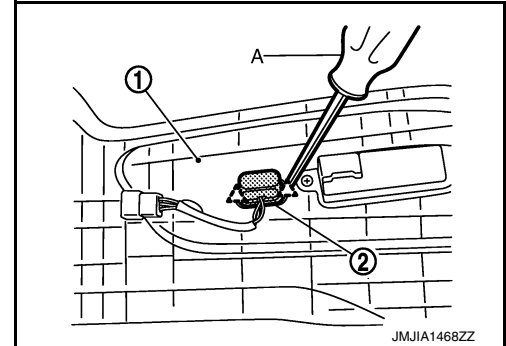

INSTALLATION

Install in the reverse order of removal.

CAUTION:

Be careful to clamp the harness to the right place.

SIDE SUPPORT SWITCH

< REMOVAL AND INSTALLATION >

SIDE SUPPORT SWITCH

Removal and Installation

INFOID:000000010584601

REMOVAL

CAUTION:

When removing and installing, use shop cloths to protect parts from damage.

1. Remove the seat cushion outer finisher (1). Refer to [SE-125, "Removal and Installation"](#).
2. Remove the screws (A).
3. Remove side support switch (2) from the seat cushion outer finisher.

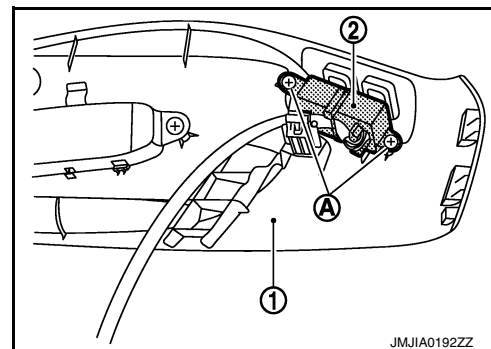

INSTALLATION

Install in the reverse order of removal.

CAUTION:

- Clamp the harness in position.

NOTE:

After installing the driver seat, perform additional service when removing battery negative terminal. Refer to [ADP-8, "ADDITIONAL SERVICE WHEN REMOVING BATTERY NEGATIVE TERMINAL : Description"](#).

A
B
C
D
E
F
G
H
I
K
L
M
N
O
P

SE

CLIMATE CONTROLLED SEAT SWITCH

< REMOVAL AND INSTALLATION >

CLIMATE CONTROLLED SEAT SWITCH

Exploded View

INFOID:000000010584602

Refer to [IP-23, "Exploded View"](#).

Removal and Installation

INFOID:000000010584603

REMOVAL

CAUTION:

When removing and installing, use shop cloths to protect parts from damage.

1. Remove the console upper finisher, console finisher assembly, cup holder assembly and console switch finisher. Refer to [IP-23, "Removal and Installation"](#)
2. Climate controlled seat switch (1) is removed from console switch finisher (2) using remover tool (A).

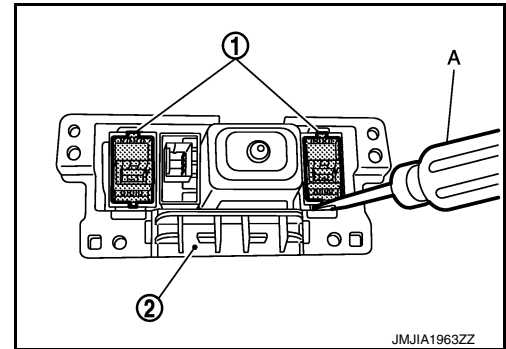

INSTALLATION

Install in the reverse order of removal.

CLIMATE CONTROLLED SEAT BLOWER FILTER

< REMOVAL AND INSTALLATION >

CLIMATE CONTROLLED SEAT BLOWER FILTER

Exploded View

INFOID:000000010584604

Refer to [SE-122. "Exploded View"](#).

Removal and Installation

INFOID:000000010584605

REMOVAL

CAUTION:

When removing and installing, use shop cloths to protect parts from damage.

1. Disconnect seat cushion rear fixing belt.
2. Turn blower filter (1) counter clockwise and remove it from climate controlled seat blower motor (2).

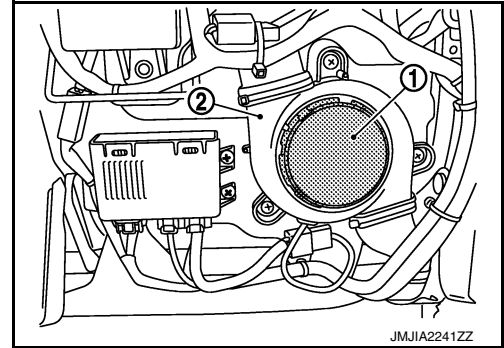

INSTALLATION

Install in the reverse order of removal.

A
B
C
D
E
F
G
H
I

SE

K
L
M
N
O
P

HEATED SEAT CONTROL UNIT

< REMOVAL AND INSTALLATION >

HEATED SEAT CONTROL UNIT

Exploded View

INFOID:000000010584606

Refer to [SE-122. "Exploded View"](#).

Removal and Installation

INFOID:000000010584607

REMOVAL

CAUTION:

When removing and installing, use shop cloths to protect parts from damage.

1. Remove the front seat.
2. Disconnect heated seat control unit connector.
3. Remove the heated seat control unit from the heated seat control unit stay. Refer to [SE-125. "Removal and Installation"](#).

INSTALLATION

Install in the reverse order of removal.

CAUTION:

Always clamp the harness to the right place.

HEATED SEAT SWITCH

< REMOVAL AND INSTALLATION >

HEATED SEAT SWITCH

Exploded View

INFOID:0000000110584608

Refer to [JP-23, "Exploded View"](#).

Removal and Installation

INFOID:0000000110584609

REMOVAL

CAUTION:

When removing and installing, use shop cloths to protect parts from damage.

1. Remove the console upper finisher, console finisher assembly, cup holder assembly and console switch finisher. Refer to [JP-23, "Removal and Installation"](#).
2. Heated seat switch (1) is removed from console switch finisher (2) using remover tool (A).

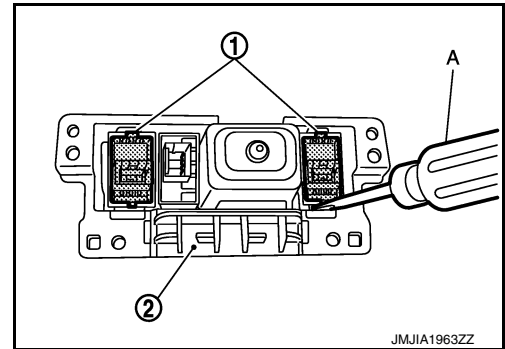

INSTALLATION

Install in the reverse order of removal.

A
B
C
D
E
F
G
H
I
K
L
M
N
O
P

SE