

A
CO
C
D
E
F
G
H
I
J
K
L
M
N
O
P

SECTION CO

ENGINE COOLING SYSTEM

CONTENTS

<p style="text-align: center;">VQ35DE</p> <p>PRECAUTION 2</p> <p>PRECAUTIONS 2</p> <p style="padding-left: 20px;">Precaution for Supplemental Restraint System (SRS) "AIR BAG" and "SEAT BELT PRE-TENSIONER"2</p> <p style="padding-left: 20px;">Precaution for Liquid Gasket2</p> <p>PREPARATION 4</p> <p>PREPARATION 4</p> <p style="padding-left: 20px;">Special Service Tool4</p> <p style="padding-left: 20px;">Commercial Service Tool4</p> <p>SYSTEM DESCRIPTION 6</p> <p>OVERHEATING CAUSE ANALYSIS 6</p> <p style="padding-left: 20px;">Troubleshooting Chart6</p> <p>COOLING SYSTEM 8</p> <p style="padding-left: 20px;">Cooling Circuit8</p> <p style="padding-left: 20px;">Schematic9</p> <p>PERIODIC MAINTENANCE10</p> <p>ENGINE COOLANT10</p> <p style="padding-left: 20px;">System Inspection10</p> <p style="padding-left: 20px;">Changing Engine Coolant11</p>	<p>REMOVAL AND INSTALLATION15</p> <p>RADIATOR15</p> <p style="padding-left: 20px;">Exploded View15</p> <p style="padding-left: 20px;">Removal and Installation15</p> <p>COOLING FAN17</p> <p style="padding-left: 20px;">Exploded View17</p> <p style="padding-left: 20px;">Removal and Installation17</p> <p>WATER PUMP19</p> <p style="padding-left: 20px;">Exploded View19</p> <p style="padding-left: 20px;">Removal and Installation19</p> <p>THERMOSTAT AND THERMOSTAT HOUSING24</p> <p style="padding-left: 20px;">Exploded View24</p> <p style="padding-left: 20px;">Removal and Installation24</p> <p>WATER OUTLET AND WATER PIPING26</p> <p style="padding-left: 20px;">Exploded View26</p> <p style="padding-left: 20px;">Removal and Installation26</p> <p>SERVICE DATA AND SPECIFICATIONS (SDS)28</p> <p>SERVICE DATA AND SPECIFICATIONS (SDS)28</p> <p style="padding-left: 20px;">Capacity28</p> <p style="padding-left: 20px;">Thermostat28</p> <p style="padding-left: 20px;">Radiator28</p>
-------------------------------------------------------------------------------------------------------------------------------------------------------------------------------------------------------------------------------------------------------------------------------------------------------------------------------------------------------------------------------------------------------------------------------------------------------------------------------------------------------------------------------------------------------------------------------------------------------------------------------------------------------------------------------------------------------------------------------------------------------------------------------------------------------------------------------------------------------------------------------------------------------------------------------------------------------------------------------------------------------------------------------------------------------------------	-----------------------------------------------------------------------------------------------------------------------------------------------------------------------------------------------------------------------------------------------------------------------------------------------------------------------------------------------------------------------------------------------------------------------------------------------------------------------------------------------------------------------------------------------------------------------------------------------------------------------------------------------------------------------------------------------------------------------------------------------------------------------------------------------------------------------------------------------------------------------------------------------------------------------------------------------------------------------------------------------------------------------------------------------------------------------------------------------------------------------------------------------------------------------------------------------------

PRECAUTION

PRECAUTIONS

Precaution for Supplemental Restraint System (SRS) "AIR BAG" and "SEAT BELT PRE-TENSIONER"

INFOID:000000009135576

The Supplemental Restraint System such as "AIR BAG" and "SEAT BELT PRE-TENSIONER", used along with a front seat belt, helps to reduce the risk or severity of injury to the driver and front passenger for certain types of collision. This system includes dual stage front air bag modules. The SRS system may only deploy one front air bag, depending on the severity of a collision and whether the front passenger seat is occupied. Information necessary to service the system safely is included in the SR and SB section of this Service Manual.

WARNING:

- To avoid rendering the SRS inoperative, which could increase the risk of personal injury or death in the event of a collision which would result in air bag inflation, all maintenance must be performed by an authorized NISSAN/INFINITI dealer.
- Improper maintenance, including incorrect removal and installation of the SRS, can lead to personal injury caused by unintentional activation of the system. For removal of Spiral Cable and Air Bag Module, see the SR section.
- Do not use electrical test equipment on any circuit related to the SRS unless instructed to in this Service Manual. SRS wiring harnesses can be identified by yellow and/or orange harnesses or harness connectors.

PRECAUTIONS WHEN USING POWER TOOLS (AIR OR ELECTRIC) AND HAMMERS

WARNING:

- When working near the Airbag Diagnosis Sensor Unit or other Airbag System sensors with the Ignition ON or engine running, DO NOT use air or electric power tools or strike near the sensor(s) with a hammer. Heavy vibration could activate the sensor(s) and deploy the air bag(s), possibly causing serious injury.
- When using air or electric power tools or hammers, always switch the Ignition OFF, disconnect the battery, and wait at least three minutes before performing any service.

Precaution for Liquid Gasket

INFOID:000000009135577

REMOVAL OF LIQUID GASKET

- After removing the bolts and nuts, separate the mating surface and remove the old liquid gasket using Tool.

Tool number : KV10111100 (J-37228)

CAUTION:

Do not damage the mating surfaces.

- Tap the pan seal cutter to insert it (1).
- In areas where the Tool is difficult to use, lightly tap to slide it (2).

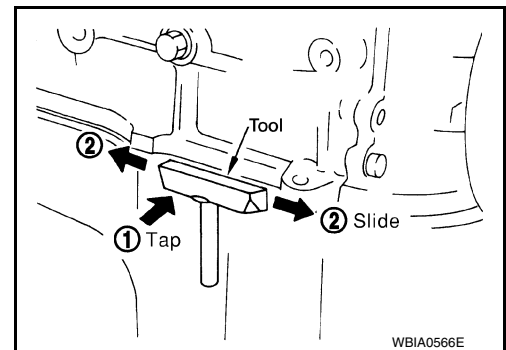

WBIA0566E

LIQUID GASKET APPLICATION PROCEDURE

PRECAUTIONS

[VQ35DE]

< PRECAUTION >

1. Using suitable tool (A), remove old liquid gasket adhering to the liquid gasket application surface and the mating surface.
 - Remove liquid gasket completely from the groove of the liquid gasket application surface, mounting bolts, and bolt holes.
2. Wipe the liquid gasket application surface and the mating surface with white gasoline (lighting and heating use) to remove adhering moisture, grease and foreign materials.

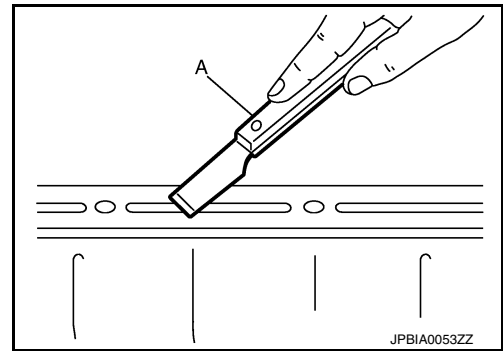

3. Attach the liquid gasket tube to the suitable tool.
Use Genuine RTV Silicone Sealant or equivalent. Refer to [GI-22, "Recommended Chemical Products and Sealants"](#).
4. Apply the liquid gasket without gaps to the specified location with the specified dimensions.

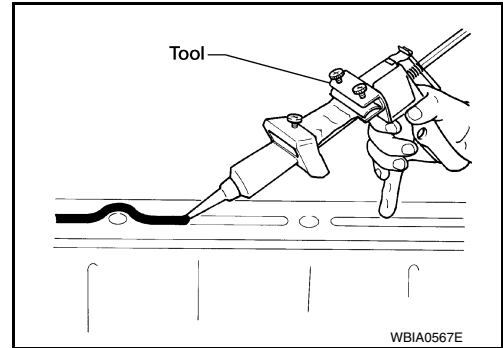

- If there is a groove for the liquid gasket application, apply the liquid gasket to the groove.
- Normally apply the liquid gasket on the inside edge of the bolt holes. Also apply to the outside edge of the bolt holes when specified in the procedure.
- Within five minutes of liquid gasket application, install the mating component.
- If the liquid gasket protrudes, wipe it off immediately.
- Do not retighten mounting bolts after the installation.
- Wait 30 minutes or more after installation before refilling the engine with engine oil or engine coolant.

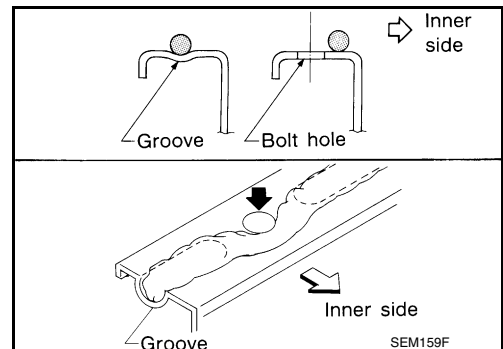

CAUTION:

If there are more specific instructions in the procedures contained in this manual concerning liquid gasket application, observe them.

PREPARATION

< PREPARATION >

[VQ35DE]

PREPARATION

PREPARATION

Special Service Tool

INFOID:000000009135578

The actual shapes of Kent-Moore tools may differ from those of special service tools illustrated here.

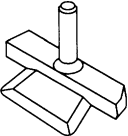
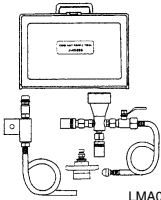
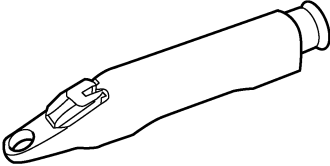
Tool number (Kent-Moore No.) Tool name	Description
KV10111100 (J-37228) Seal cutter  NT046	Removing chain tensioner cover and water pump cover
KV991J0070 (J-45695-A) Coolant refill tool  LMA053	Refilling engine cooling system
KV991J0010 (J-23688) Refractometer  WBIA0539E	Checking concentration of ethylene glycol in engine coolant

Commercial Service Tool

INFOID:000000009135579

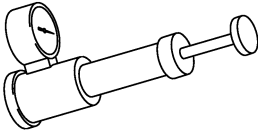
Tool name	Description
Power tool  PIIB1407E	Loosening nuts, screws and bolts
Radiator cap tester  PBIC1982E	Testing radiator cap

PREPARATION

< PREPARATION >

[VQ35DE]

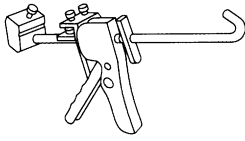
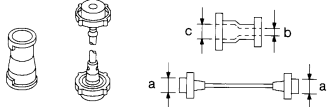
Tool name	Description
<p>Tube presser</p>  <p style="text-align: center;">S-NT052</p>	<p>Pressing the tube of liquid gasket</p>
<p>Radiator cap tester adapter</p>  <p style="text-align: center;">S-NT564</p>	<p>Adapting radiator cap tester to radiator cap and radiator pipe (upper) filler neck</p> <p>a: 28 (1.10) diameter b: 31.4 (1.236) diameter c: 41.3 (1.626) diameter Unit: mm (in)</p>

A

CO

C

D

E

F

G

H

I

J

K

L

M

N

O

P

OVERHEATING CAUSE ANALYSIS

< SYSTEM DESCRIPTION >

[VQ35DE]

SYSTEM DESCRIPTION

OVERHEATING CAUSE ANALYSIS

Troubleshooting Chart

INFOID:000000009135580

		Symptom	Check items		
Cooling system parts malfunction	Poor heat transfer	Water pump malfunction	Worn or loose drive belt	Engine coolant circulation	
		Thermostat stuck closed	Thermostat		
		Damaged radiator fins	Dust contamination or paper clogging	Physical damage	—
			Clogged radiator cooling tube		
	Reduced air flow	Cooling fan motor assembly does not operate	Cooling fan motor assembly	—	
		High resistance to fan rotation			
		Damaged fan blades			
	Damaged radiator shroud	—	Radiator shroud	—	
	Improper engine coolant mixture ratio	—	Engine coolant viscosity	—	
	Poor engine coolant quality	—	Engine coolant density	—	
	Insufficient engine coolant	Engine coolant leaks	Radiator and heater hoses	Loose clamp	
				Cracked hose	
			Water pump	Poor sealing	
			Radiator cap	Loose	
				Poor sealing	
Radiator			O-ring for damage, deterioration or improper fitting		
		Cracked radiator tank			
	Cracked radiator core				
Coolant reservoir tank	Cracked coolant reservoir tank				
Overflowing coolant reservoir tank	Exhaust gas leaks into cooling system	Cylinder head deterioration			
		Cylinder head gasket deterioration			

OVERHEATING CAUSE ANALYSIS

< SYSTEM DESCRIPTION >

[VQ35DE]

	Symptom		Check items			
Except cooling system parts malfunction	—	Overload on engine	Abusive driving	High engine rpm under no load	A	
				Driving in low gear for extended time	CO	
				Driving at extremely high speed		
				Powertrain system malfunction		C
				Improper size wheels and tires installed	—	D
				Brakes dragging		
		Improper ignition timing		E		
	—	Blocked or restricted air flow	Blocked bumper		E	
			Blocked condenser			
			Blocked radiator		F	
			Blocked radiator grille	—		
			Car brassiere installed		G	
			Large fog lamp installed			
			Mud contamination or paper clogging		H	

COOLING SYSTEM

[VQ35DE]

< SYSTEM DESCRIPTION >

COOLING SYSTEM

Cooling Circuit

INFOID:000000009135581

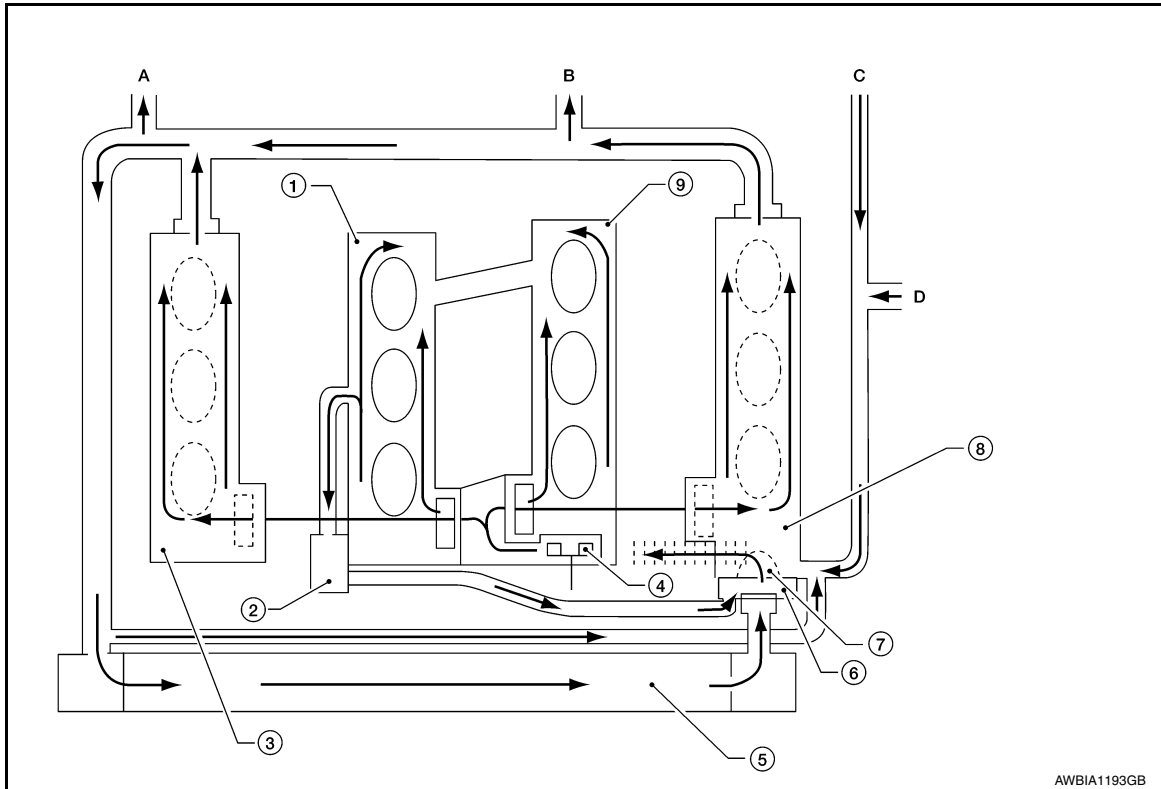

AWBIA1193GB

- | | | |
|-----------------------------------|---------------------------------|------------------------|
| 1. Cylinder block (RH) | 2. Oil cooler | 3. Cylinder head (RH) |
| 4. Water pump | 5. Radiator | 6. Water outlet |
| 7. Thermostat | 8. Cylinder head (LH) | 9. Cylinder block (LH) |
| A. To heater | B. To electric throttle control | C. From heater |
| D. From electric throttle control | | |

COOLING SYSTEM

< SYSTEM DESCRIPTION >

[VQ35DE]

Schematic

INFOID:000000009135582

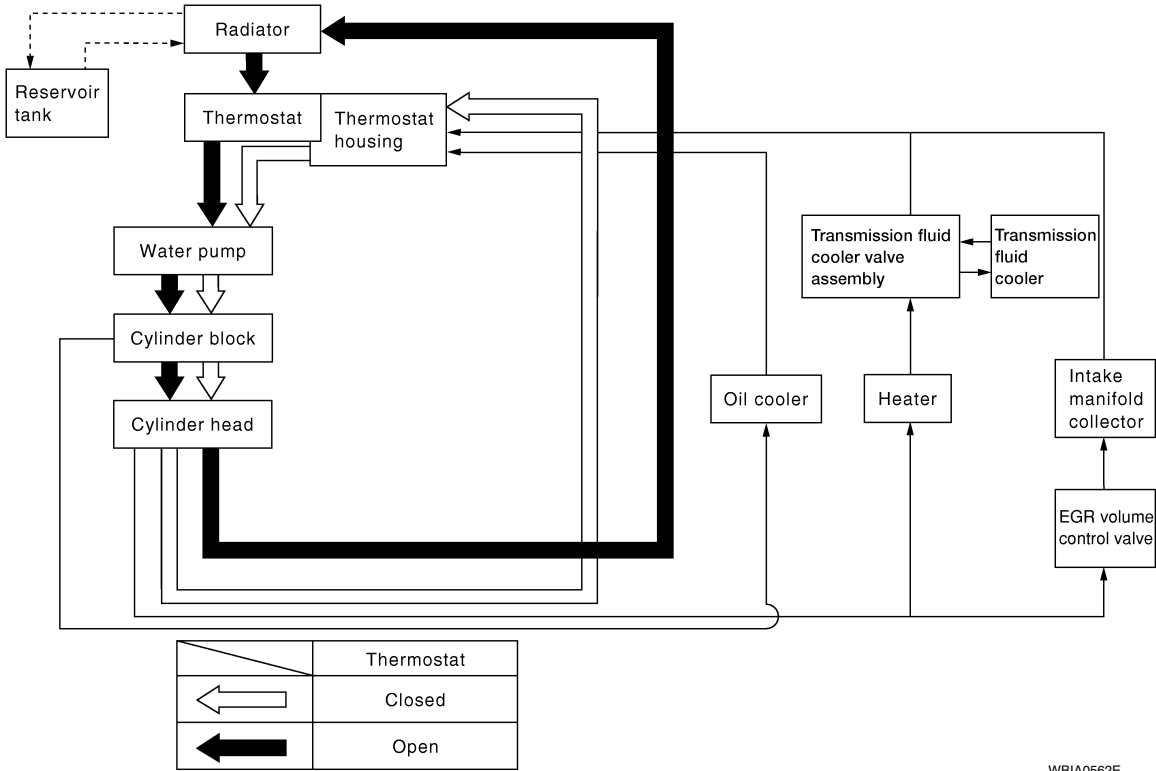

WBIA0562E

A
CO
C
D
E
F
G
H
I
J
K
L
M
N
O
P

PERIODIC MAINTENANCE

ENGINE COOLANT

System Inspection

INFOID:000000009135583

WARNING:

Do not remove the radiator cap when the engine is hot. Serious burns could occur from high pressure engine coolant escaping from the radiator. Wrap a thick cloth around the cap. Slowly turn it a quarter turn to allow built-up pressure to escape. Carefully remove the cap by turning it all the way.

CHECKING COOLING SYSTEM HOSES

Check hoses for the following:

- Improper attachment
- Leaks
- Cracks
- Damage
- Loose connections
- Chafing
- Deterioration

CHECKING RESERVOIR LEVEL

- Check the coolant reservoir tank level when the engine is cool.
- Adjust engine coolant level, if necessary, to ensure that the engine coolant level is within the MIN to MAX range.

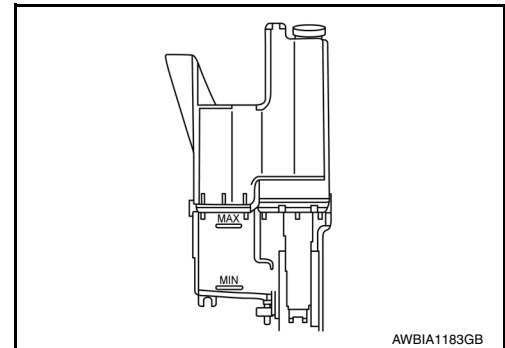

CHECKING COOLING SYSTEM FOR LEAKS

To check for leaks, apply pressure to the cooling system using suitable tool (A) and Tool (B).

Tool number (B) : EG17650301 (J-33984-A)

Testing pressure : Refer to [CO-28, "Radiator"](#).

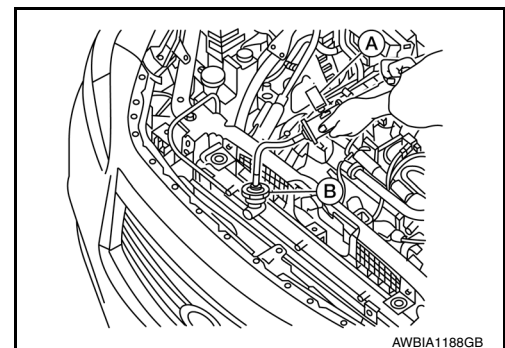

WARNING:

Do not remove the radiator cap when the engine is hot. Serious burns could occur from high pressure engine coolant escaping from the radiator.

CAUTION:

Higher test pressure than specified may cause radiator damage.

CHECKING RADIATOR CAP

1. Inspect the radiator cap.
 - Replace the cap if the metal plunger cannot be seen around the edge of the black rubber gasket.
 - Replace the cap if deposits of waxy residue or other foreign material are on the black rubber gasket or the metal retainer.

NOTE:

Thoroughly wipe out the radiator filler neck to remove any waxy residue or foreign material.

ENGINE COOLANT

< PERIODIC MAINTENANCE >

[VQ35DE]

2. Pull the negative-pressure valve to open it and check that it closes completely when released.
 - Check that there is no dirt or damage on the valve seat of the radiator cap negative-pressure valve.
 - Check that there are no abnormalities in the opening and closing conditions of the negative-pressure valve.

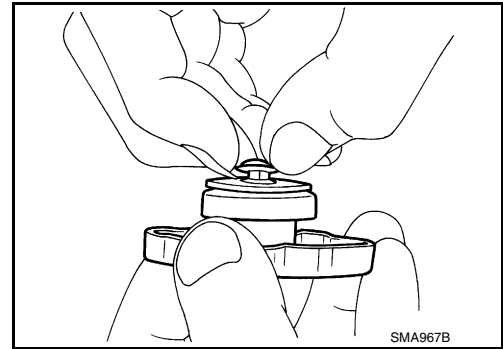

3. Check radiator cap relief pressure using suitable tool (A) and Tool (B).

Tool number (B) : EG17650301 (J-33984-A)

Standard : Refer to [CO-28, "Radiator"](#).

- Apply water or engine coolant to the cap seal surface before connecting the radiator cap to the tester,
- Replace the radiator cap if there is an abnormality in the negative-pressure valve, or if the open-valve pressure is outside of the standard values.

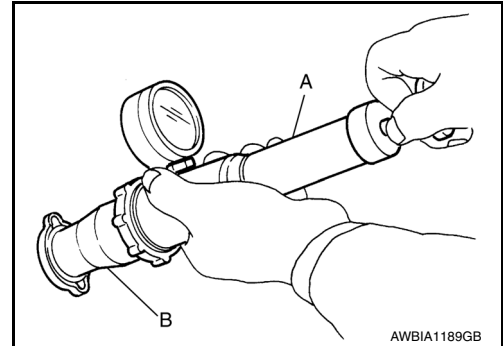

CHECKING RADIATOR

Check radiator for mud or clogging. If necessary, clean radiator as follows.

CAUTION:

- **Be careful not to bend or damage the radiator fins.**
- **When radiator is cleaned on-vehicle, remove surrounding parts in order to access the radiator core.**
Tap the harness and harness connectors to prevent water from entering.

1. Spray water to the back side of the radiator core using a side to side motion from the top down.
2. Stop spraying when debris no longer flows from radiator core.
3. Blow air into the back side of radiator core using a side to side motion from the top down.
 - Use compressed air lower than 490 kPa (5.00 kg/cm², 71.1 psi) and keep distance more than 30 cm (11.8 in).
4. Continue to blow air until no water sprays out.
5. Check for engine coolant leaks. Repair as necessary.

Changing Engine Coolant

INFOID:000000009135584

WARNING:

Do not remove the radiator cap when the engine is hot. Serious burns could occur from high pressure engine coolant escaping from the radiator. Wrap a thick cloth around the cap. Slowly turn it a quarter turn to allow built-up pressure to escape. Carefully remove the cap by turning it all the way.

DRAINING ENGINE COOLANT

1. Open radiator drain plug (1) at the bottom of radiator and remove the radiator filler cap.

CAUTION:

Do not allow the engine coolant to contact the drive belt.

↶ : Front

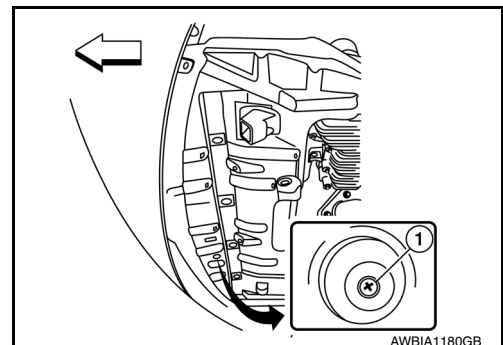

ENGINE COOLANT

[VQ35DE]

< PERIODIC MAINTENANCE >

2. Remove water drain plug (A) and copper sealing washer (B).

CAUTION:

Do not reuse copper sealing washers.

← : Front

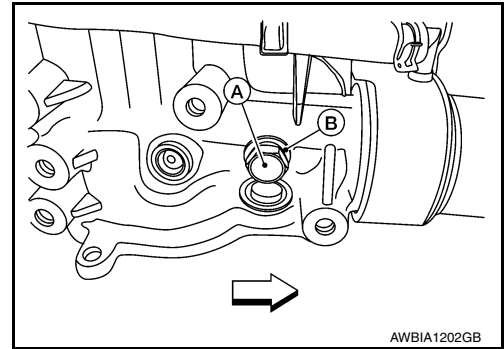

3. For a complete cooling system drain, remove the reservoir tank and drain the engine coolant, and then clean the reservoir tank before installation.

CAUTION:

Do not allow the engine coolant to contact the drive belt.

4. When performing a complete cooling system drain, remove the water drain plug (B), connector bolt (C), and copper sealing washer (A) on the cylinder block.

CAUTION:

Do not reuse copper sealing washers.

NOTE:

- For Canada, water drain plug (B) is a block heater, not a drain plug.
- Remove water drain plug (D) and copper sealing washer (E) during engine overhaul.

CAUTION:

Do not reuse copper sealing washers.

← : Front

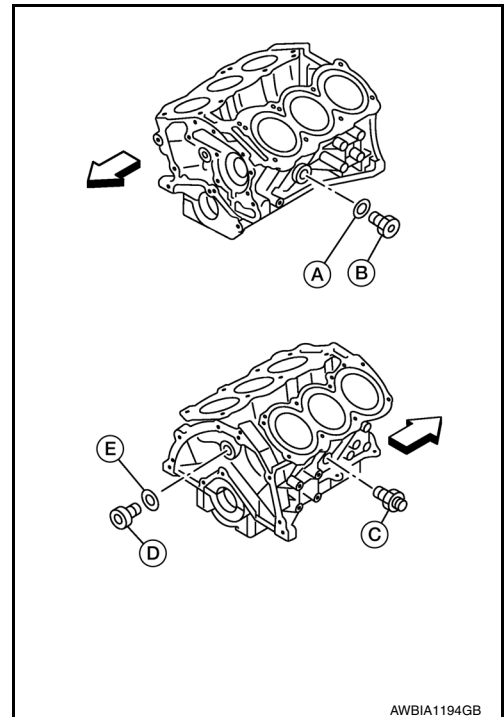

5. Check the drained engine coolant for contaminants such as rust, corrosion or discoloration.
 - If contaminated, flush the engine cooling system. Refer to FLUSHING COOLING SYSTEM.

REFILLING ENGINE COOLANT

1. Install the radiator drain plug and the reservoir tank, (if removed).
2. Install the water drain plug (A) and copper sealing washer (B). Tighten water drain plug to specification.

CAUTION:

Do not reuse copper sealing washers.

← : Front

Water drain plug (A) : 12.25 N·m (1.2 kg-m, 9.0 ft-lb)

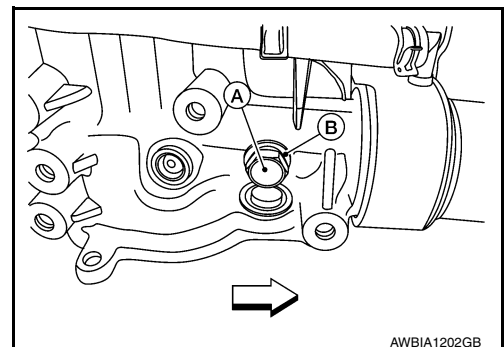

ENGINE COOLANT

[VQ35DE]

< PERIODIC MAINTENANCE >

3. Install the cylinder block drain plugs (if removed).
 - Apply sealant to the thread of the water drain plug (B), connector bolt (C) and water drain plug (D), (if removed).

CAUTION:

Do not reuse copper sealing washers.

← : Front

NOTE:

- For Canada, water drain plug (B) in is a block heater, not a water drain plug.
- Install copper sealing washers (E) and (A), (if removed).
- Use Genuine High Performance Thread Sealant or equivalent. Refer to [GI-22, "Recommended Chemical Products and Sealants"](#).
- Tighten each plug and connector bolt to specifications.

Water drain plug (B) : 62.0 N·m (6.3 kg-m, 46 ft-lb)

Connector Bolt (C) : 27.0 N·m (2.8 kg-m, 20 ft-lb)

Water drain plug (D) : 78.0 N·m (8.0 kg-m, 58 ft-lb)

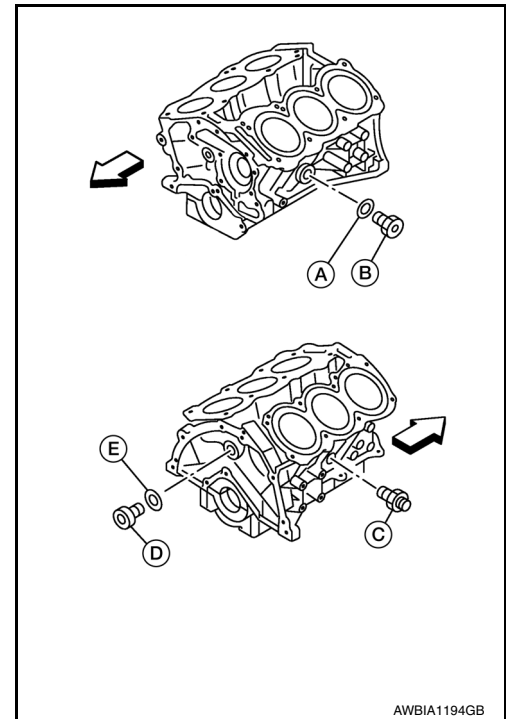

4. If disconnected, reattach the upper radiator hose at the engine side.
5. Set the vehicle heater controls to the full HOT and heater ON position. Turn the vehicle ignition ON with the engine OFF as necessary to activate the heater mode.
6. Install the Tool by installing the radiator cap adapter onto the radiator neck opening. Then attach the gauge body assembly with the refill tube and the Venturi assembly to the radiator cap adapter.

Tool number : KV991J0070 (J-45695)

7. Insert the refill hose into the engine coolant mixture container that is placed at floor level. Make sure the ball valve is in the closed position.
 - **Use the specified engine coolant or equivalent. Refer to [MA-15, "FOR USA AND CANADA : Fluids and Lubricants"](#) (United States and Canada) or [MA-16, "FOR MEXICO : Fluids and Lubricants"](#) (Mexico).**

Engine Coolant capacity (with reservoir tank) : Refer to [MA-15, "FOR USA AND CANADA : Fluids and Lubricants"](#).

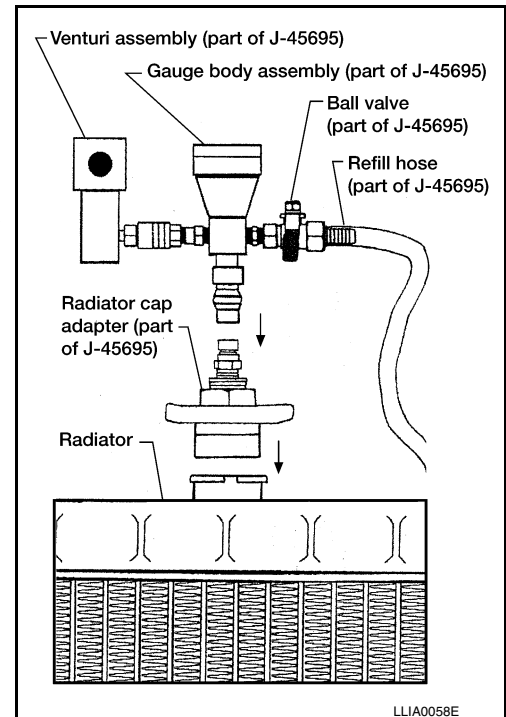

8. Install an air hose to the Venturi assembly. The air pressure must be within specification.

Compressed air supply pressure : 549 - 824 kPa (5.6 - 8.4 kg/cm², 80 - 119 psi)

CAUTION:

The compressed air supply must be equipped with an air dryer.

9. The vacuum gauge will begin to rise and there will be an audible hissing noise. During this process open the ball valve on the refill hose slightly. Rising engine coolant will be visible in the refill hose. After the refill hose is full of engine coolant, close the ball valve. This will purge air trapped in the refill hose.

ENGINE COOLANT

< PERIODIC MAINTENANCE >

[VQ35DE]

10. Continue to draw the vacuum until the gauge reaches 28 inches of vacuum. The gauge may not reach 28 inches in high altitude locations. Refer to the following table for expected vacuum readings.

Altitude above sea level	Vacuum gauge reading
0 - 100 m (328 ft)	: 28 inches of vacuum
300 m (984 ft)	: 27 inches of vacuum
500 m (1,641 ft)	: 26 inches of vacuum
1,000 m (3,281 ft)	: 24 - 25 inches of vacuum

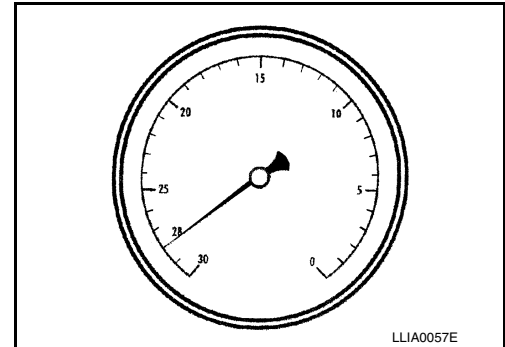

11. When the vacuum gauge has reached the specified amount, disconnect the air hose and wait 20 seconds to see if the system loses vacuum. If the vacuum level drops, perform necessary repairs to the system and repeat steps 6 - 8 to bring the vacuum to the specified amount. Recheck for leaks.
12. Place the engine coolant container (with the refill hose inserted) at the same level as the top of the radiator. Then open the ball valve on the refill hose so the engine coolant will be drawn up to fill the cooling system. The cooling system is full when the vacuum gauge reads zero.

CAUTION:

Do not allow the engine coolant container to get too low when filling to prevent air from being inadvertently drawn into the cooling system.

13. Remove the Tool from the radiator neck opening and install the radiator cap.
14. Fill the cooling system reservoir tank to the specified level. Run the engine to warm up the cooling system and top up the system as necessary.

FLUSHING COOLING SYSTEM

1. Fill the radiator from the filler neck above the radiator upper hose and reservoir tank with clean water and reinstall radiator filler cap.
2. Run the engine until it is at normal operating temperature.
3. Rev the engine two or three times under no-load.
4. Stop the engine and wait until it cools down.
5. Drain the water from the system. Refer to [CO-11. "Changing Engine Coolant"](#).
6. Repeat steps 1 through 5 until clear water begins to drain from the radiator.

RADIATOR

< REMOVAL AND INSTALLATION >

[VQ35DE]

REMOVAL AND INSTALLATION

RADIATOR

Exploded View

INFOID:000000009135585

A

CO

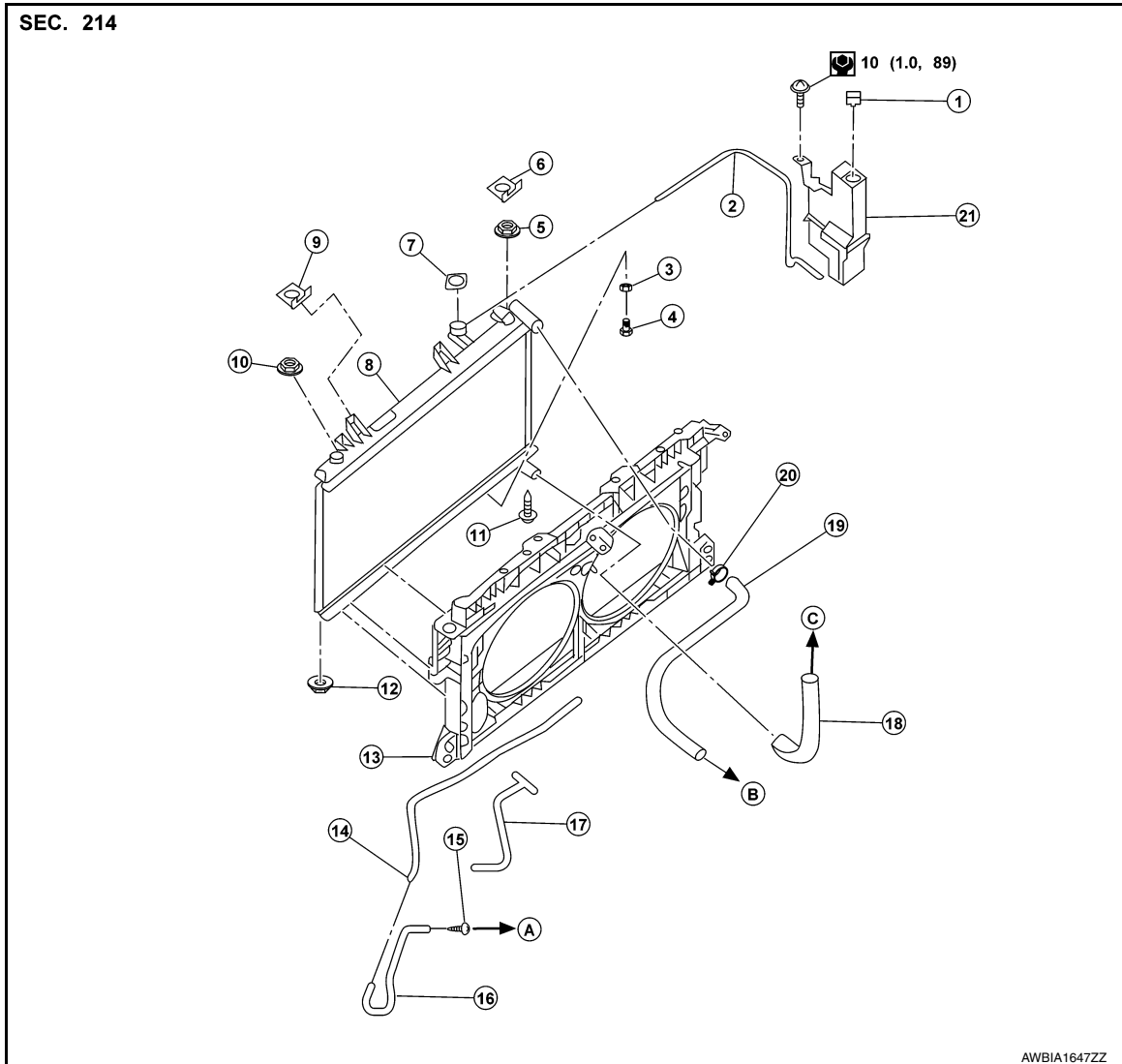

- | | | |
|--------------------------------|--------------------------------|--------------------------------|
| 1. Reservoir tank cap | 2. Reservoir tank hose | 3. O-ring |
| 4. Drain plug | 5. Mounting rubber (upper) RH | 6. Radiator mount (upper) RH |
| 7. Radiator cap | 8. Radiator | 9. Radiator mount (upper) LH |
| 10. Mounting rubber (upper) LH | 11. Mounting rubber (lower) RH | 12. Mounting rubber (lower) LH |
| 13. Radiator core support | 14. CVT fluid cooler pipe | 15. CVT oil cooler hose clamp |
| 16. CVT oil cooler hose | 17. CVT oil cooler hose | 18. Radiator hose (lower) |
| 19. Radiator hose (upper) | 20. Radiator hose clamp | 21. Reservoir tank |
| A. To CVT | B. To water inlet | C. To water outlet |

Removal and Installation

INFOID:000000009135586

WARNING:

Do not remove the radiator cap when the engine is hot. Serious burns could occur from high pressure engine coolant escaping from the radiator. Wrap a thick cloth around the cap. Slowly turn it a quarter turn to allow built-up pressure to escape. Carefully remove the cap by turning it all the way.

NOTE:

C

D

E

F

G

H

I

J

K

L

M

N

O

P

RADIATOR

[VQ35DE]

< REMOVAL AND INSTALLATION >

- When removing components such as hoses, tubes/lines, etc., cap or plug openings to prevent fluid from spilling.
- The radiator hose clamps on the radiator hose (upper) and on the radiator hose (lower), are not serviced separately. Radiator hose clamps are part of the radiator hose assembly and serviced as one unit with the radiator hose.

REMOVAL

1. Disconnect the negative battery terminal. Refer to [PG-93, "Removal and Installation"](#).
2. Drain engine coolant from radiator. Refer to [CO-11, "Changing Engine Coolant"](#).

CAUTION:

- Perform this step when the engine is cold.
- Do not spill engine coolant on the drive belt.

3. Remove core support cover. Refer to [HA-39, "Exploded View"](#).
4. Remove front air duct. Refer to [EM-24, "Removal and Installation"](#).
5. Disconnect coolant reservoir hose from the radiator.
6. Remove front under cover. Refer to [EXT-16, "Exploded View"](#).
7. Disconnect radiator hose (upper) and radiator hose (lower) from the radiator.

CAUTION:

Do not allow the engine coolant to contact the drive belt.

NOTE:

The radiator hose clamps on the radiator hose (upper) and on the radiator hose (lower), are not serviced separately. Radiator hose clamps are part of the radiator hose assembly and serviced as one unit with the radiator hose.

8. Disconnect the CVT oil cooler hoses.
9. Disconnect hood lock switch and cable. Refer to [DLK-269, "Exploded View"](#).
10. Remove the hood lock assembly. Refer to [DLK-269, "Exploded View"](#).
11. Remove the front bumper fascia. Refer to [EXT-16, "Exploded View"](#).
12. Remove the core support center brace. Refer to [EXT-16, "Exploded View"](#).
13. Remove the headlamp assemblies. Refer to [EXL-160, "Removal and Installation"](#).
14. Remove A/C condenser. Refer to [HA-39, "Removal and Installation"](#).

CAUTION:

Be careful not to damage condenser core.

15. Remove the radiator mounts (upper).
16. Remove radiator.

CAUTION:

- Do not damage or scratch the radiator core when removing.

INSTALLATION

Installation is in the reverse order of removal.

- After installation, refill engine coolant and check for leaks. Refer to [CO-11, "Changing Engine Coolant"](#) and [CO-10, "System Inspection"](#).

CAUTION:

Do not spill engine coolant in engine compartment. Use a shop cloth to absorb engine coolant.

COOLING FAN

Exploded View

INFOID:000000009135587

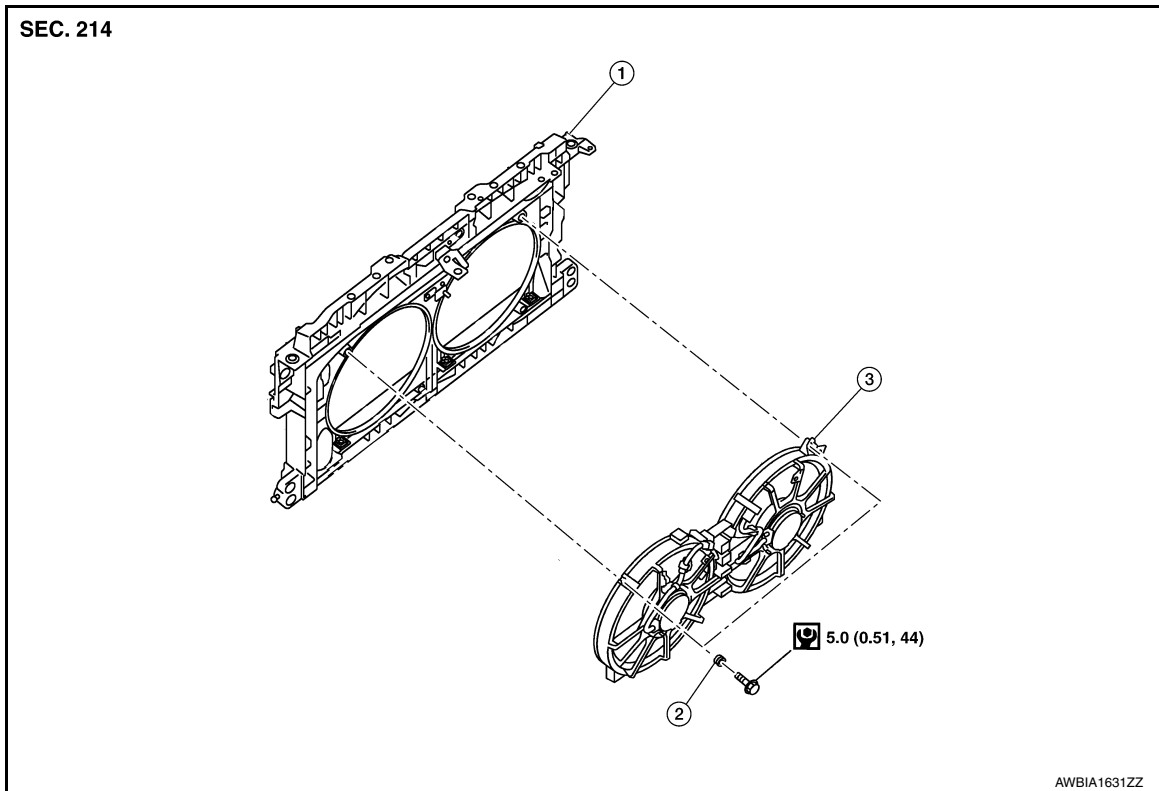

1. Radiator core support

2. Grommet

3. Cooling fan motor assembly

Removal and Installation

INFOID:000000009135588

WARNING:

Do not remove the radiator cap when the engine is hot. Serious burns could occur from high pressure engine coolant escaping from the radiator. Wrap a thick cloth around the cap. Slowly turn it a quarter turn to allow built-up pressure to escape. Carefully remove the cap by turning it all the way.

NOTE:

- When removing components such as hoses, tubes/lines, etc., cap or plug openings to prevent fluid from spilling.
- Replace cooling fan motor assembly as a unit.

REMOVAL

1. Partially drain engine coolant from radiator. Refer to [CO-11, "Changing Engine Coolant"](#).

CAUTION:

- Perform when engine is cold.
 - Do not spill engine coolant on the drive belt.
2. Remove engine room cover. Refer to [EM-23, "Removal and Installation"](#).
 3. Remove air cleaner and air duct assembly. Refer to [EM-24, "Removal and Installation"](#).
 4. Remove blow by hose. Refer to [EM-43, "Exploded View"](#).
 5. Remove battery, battery tray, and battery tray bracket. Refer to [PG-93, "Removal and Installation"](#).
 6. Remove transmission air breather hose. Refer to [TM-194, "Exploded View"](#).
 7. Disconnect cooling fan control module harness connector.
 8. Remove cooling fan control control module.
 9. Remove cooling fan motor assembly.

COOLING FAN

< REMOVAL AND INSTALLATION >

[VQ35DE]

INSTALLATION

Installation is in the reverse order of removal.

- Cooling fan motor assembly is controlled by ECM. For details, refer to [EC-436, "Diagnosis Procedure"](#).

WATER PUMP

< REMOVAL AND INSTALLATION >

[VQ35DE]

WATER PUMP

Exploded View

INFOID:000000009135589

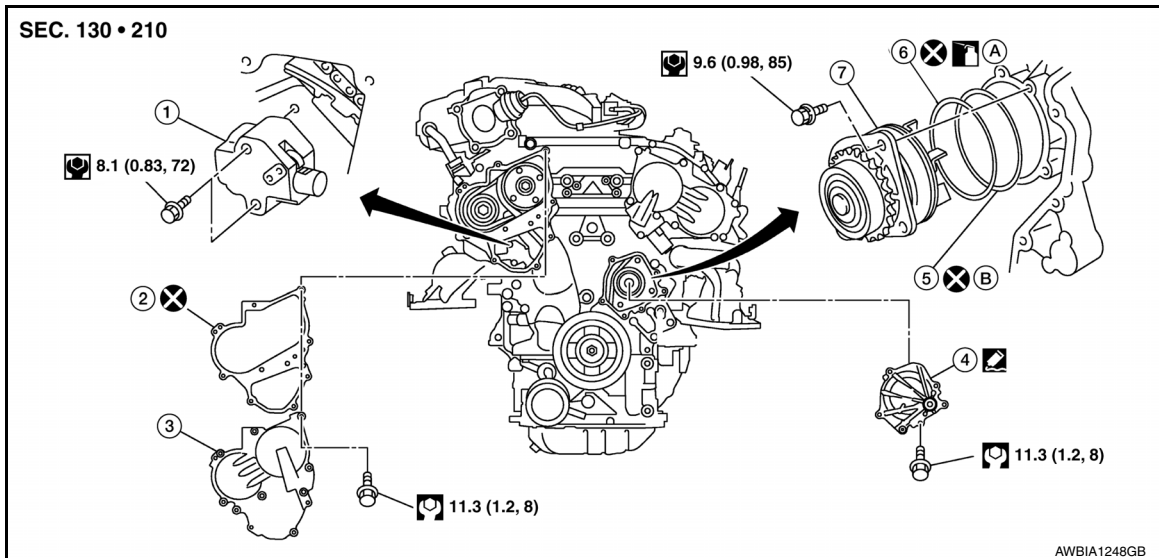

- | | | |
|-------------------------------------|-----------------------------------------------|----------------------------------------|
| 1. Timing chain tensioner (primary) | 2. Valve timing control cover gasket (bank 1) | 3. Valve timing control cover (bank 1) |
| 4. Water pump cover | 5. O-ring | 6. O-ring |
| 7. Water pump | A. Apply engine coolant | B. Identify with white mark |

Removal and Installation

INFOID:000000009135590

WARNING:

Do not remove the radiator cap when the engine is hot. Serious burns could occur from high pressure engine coolant escaping from the radiator. Wrap a thick cloth around the cap. Slowly turn it a quarter turn to allow built-up pressure to escape. Carefully remove the cap by turning it all the way.

CAUTION:

- When removing water pump assembly, be careful not to get engine coolant on drive belt.
- Water pump cannot be disassembled and must be replaced as a unit.
- After installing the water pump, connect hose and clamp securely, then check for leaks. Repair as necessary.

NOTE:

When removing components such as hoses, tubes/lines, etc., cap or plug openings to prevent fluid from spilling.

REMOVAL

1. Disconnect the negative battery terminal. Refer to [PG-93. "Removal and Installation"](#).
2. Remove the engine room cover: Refer to [EM-23. "Removal and Installation"](#).
3. Remove front air duct. Refer to [EM-24. "Removal and Installation"](#).
4. Remove engine under cover. Refer to [EXT-16. "Exploded View"](#).
5. Drain engine coolant from the radiator. Refer to [CO-11. "Changing Engine Coolant"](#).

CAUTION:

Perform when the engine is cold.

6. Drain the power steering fluid reservoir. Refer to [ST-44. "Draining and Refilling"](#).
7. Remove the front road wheel and tire (RH). Refer to [WT-53. "Adjustment"](#).
8. Remove the fender protector (RH). Refer to [EXT-28. "FENDER PROTECTOR : Removal and Installation"](#).
9. Disconnect engine coolant reservoir hose and remove engine coolant reservoir tank.
10. Set No. 1 cylinder at TDC on its compression stroke.
 - Align pointer with TDC mark on crankshaft pulley.

WATER PUMP

[VQ35DE]

< REMOVAL AND INSTALLATION >

11. Remove drive belt. Refer to [EM-12, "Removal and Installation"](#).
12. Remove the drive belt auto-tensioner assembly. Refer to [EM-14, "Removal and Installation of Drive Belt Auto-tensioner"](#).
13. Remove cylinder block water drain plug and copper sealing washer to drain engine coolant from engine.

CAUTION:

Do not reuse copper sealing washers.

⇐ : Front

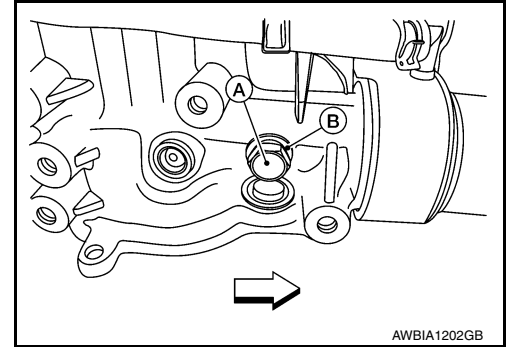

14. Remove the E-PSF cover, bracket and motor. Refer to [ST-54, "Removal and Installation"](#).
15. Support engine and remove the RH engine insulator and bracket. Refer to [EM-106, "AWD : Exploded View"](#).
16. Disconnect the A/C lines at the junction. Refer to [HA-35, "HIGH-PRESSURE PIPE : Removal and Installation"](#).
17. Disconnect RH valve timing control connectors and remove valve timing control cover (bank 1). Refer to [EM-54, "Exploded View"](#).
18. Remove water pump cover. Refer to [EM-54, "Exploded View"](#).
19. Remove the timing chain tensioner (primary) as follows:

- a. Pull the lever (C) down to release the plunger stopper tab (B).
- b. Insert the stopper pin A into the tensioner body hole to hold the lever (C) and keep the plunger stopper tab (B) released.

NOTE:

An allen wrench [(1.2 mm (0.047 in))] is used for a stopper pin A as an example.

- c. Compress the plunger (D) into the tensioner body (1) by pressing the slack guide (2).
- d. Keep the slack guide (2) pressed and lock the plunger (D) in by pushing the stopper pin A through the lever (C) and into the chain tensioner body hole.
- e. Remove timing chain tensioner bolts and then remove the timing chain tensioner.

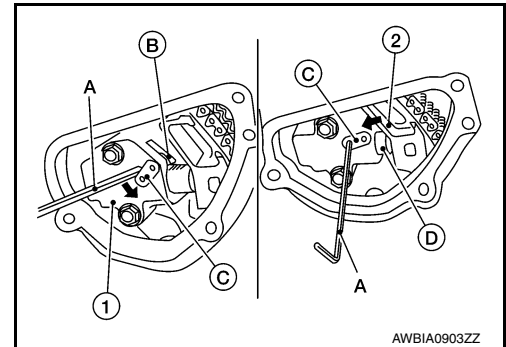

CAUTION:

Be careful not to drop timing chain tensioner bolts inside timing chain case.

20. Remove the three water pump bolts (A). Make a gap between water pump sprocket (1) and timing chain, by carefully turning crankshaft pulley (2) counterclockwise until timing chain loosens on water pump sprocket (1).

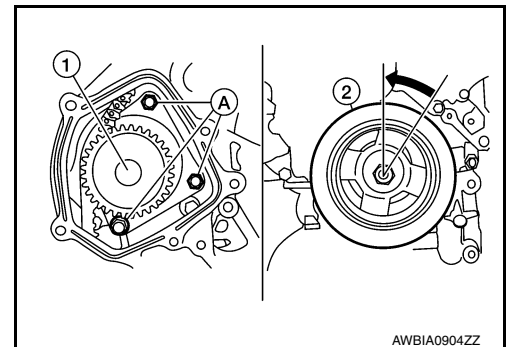

WATER PUMP

[VQ35DE]

< REMOVAL AND INSTALLATION >

21. Remove water pump:

- Screw M8 bolts approximately 50 mm (1.97 in) into water pump upper and lower bolt holes until they reach the timing chain case [M8 bolt pitch 1.25 mm (0.49 in) length].

CAUTION:

- Place a suitable shop cloth below the water pump housing to prevent any engine coolant from dripping into the timing chain case.
- Pull water pump straight out while preventing vane from contacting socket in installation area.
- Remove water pump without causing sprocket to contact timing chain.

- Remove M8 bolts and O-rings from water pump.

CAUTION:

Do not reuse O-rings.

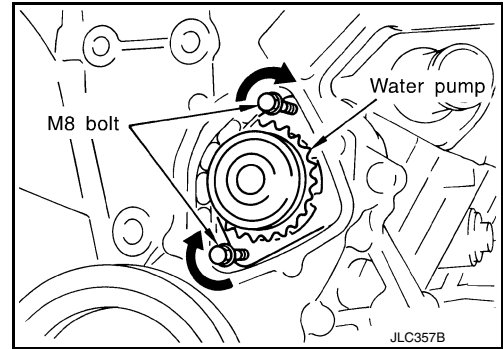

INSPECTION AFTER REMOVAL

- Visually check for significant dirt or rust on the water pump body and vane.
- Check that the vane shaft turns smoothly by hand and is not excessively loose.
- Replace the water pump assembly if the water pump does not perform properly.

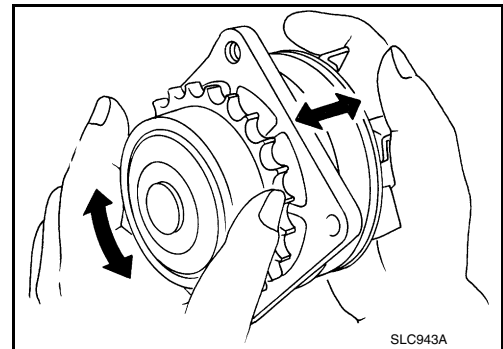

INSTALLATION

- Install new O-rings on water pump.

CAUTION:

Do not reuse O-rings.

- Apply engine oil and engine coolant to the O-rings as shown.
- Locate the O-ring with white paint mark to engine front side.

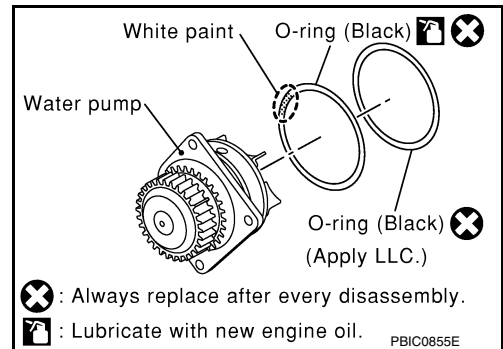

- Hold timing chain to the side (←) and install the water pump (←).

CAUTION:

Do not allow the O-rings to be damaged by the cylinder block when installing the water pump.

- Check that timing chain and water pump sprocket are engaged.
- Tighten water pump bolts alternately and evenly to specification.

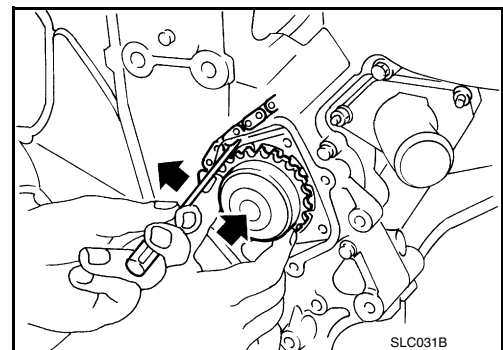

- Remove dust and foreign material completely from installation area of timing chain tensioner and rear timing chain case.

WATER PUMP

[VQ35DE]

< REMOVAL AND INSTALLATION >

- Turn the crankshaft pulley approximately 20° clockwise so that the timing chain on the timing chain tensioner side is loose.

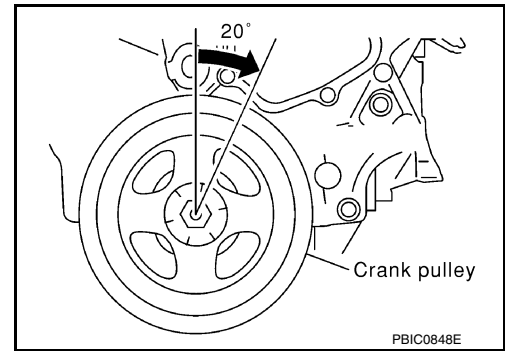

- Apply engine oil to the oil feed hole and timing chain tensioner and install the timing chain tensioner.
- Remove the stopper pin (A).

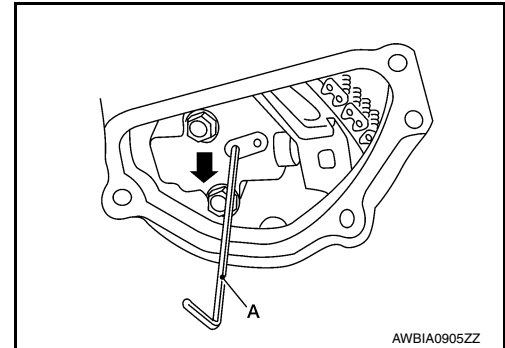

- Install valve timing control cover (bank 1) and water pump cover.
 - Before installing, remove all traces of liquid gasket from mating surface of water pump cover and IVT cover using a scraper. Also remove traces of liquid gasket from the mating surface of the front cover.
 - Apply a continuous bead of liquid gasket to mating surface of IVT cover and water pump cover. **Use Genuine RTV Silicone Sealant or equivalent. Refer to [GI-22, "Recommended Chemical Products and Sealants"](#).**

CAUTION:

- Installation should be done within 5 minutes after applying liquid gasket.
- Do not fill the engine with engine oil for at least 30 minutes after the components are installed to allow the sealant to cure.

- Install cylinder block water drain plug (A) and copper sealing washer (B).

CAUTION:

Do not reuse copper sealing washers.

↔ : Front

- Apply liquid gasket to the threads of cylinder block front drain plug. **Use Genuine RTV Silicone Sealant or equivalent. Refer to [GI-22, "Recommended Chemical Products and Sealants"](#).**

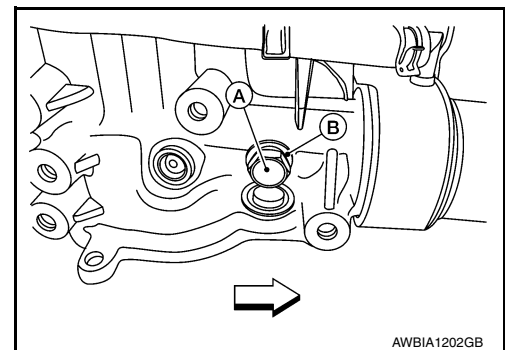

Cylinder block front drain plug : Refer to [EM-112, "Disassembly and Assembly"](#).

- Installation of remaining components is in the reverse order of removal.
 - After installation, refill engine coolant and check for leaks. Refer to [CO-11, "Changing Engine Coolant"](#) and [CO-10, "System Inspection"](#).

CAUTION:

- Do not spill engine coolant in engine compartment. Use a shop cloth to absorb engine coolant.**
- After starting engine, let idle for three minutes, then rev engine up to 3,000 rpm under no load to purge air from the high-pressure chamber of the chain tensioner. The engine may produce a rattling noise. This indicates that air still remains in the chamber and is not a matter of concern.

WATER PUMP

< REMOVAL AND INSTALLATION >

[VQ35DE]

INSPECTION AFTER INSTALLATION

- Before starting engine, check oil/fluid levels including engine coolant and engine oil. If less than required quantity, fill to the specified level. Refer to [MA-15, "FOR USA AND CANADA : Fluids and Lubricants"](#) (United States and Canada) or [MA-16, "FOR MEXICO : Fluids and Lubricants"](#) (Mexico).
- Use procedure below to check for fuel leaks.
- Turn ignition switch ON (with engine stopped). With fuel pressure applied to fuel piping, check for fuel leaks at connection points.
- Start engine. With engine speed increased, check again for fuel leaks at connection points.
- Run engine to check for unusual noise and vibration.

NOTE:

If hydraulic pressure inside timing chain tensioner drops after removal and installation, slack in the guide may generate a pounding noise during and just after engine start. However, this is normal. Noise will stop after hydraulic pressure rises.

- Warm up engine thoroughly to make sure there are no leaks of fuel, exhaust gas, or any oils/fluids including engine oil and engine coolant.
- Bleed air from passages in lines and hoses, such as in cooling system.
- After cooling down engine, again check oil/fluid levels including engine oil and engine coolant. Refill to specified level, if necessary.
- Summary of the inspection items:

Item	Before starting engine	Engine running	After engine stopped	
Engine coolant	Level	Leaks	Level	
Engine oil	Level	Leaks	Level	
Transaxle fluid	CVT Models	Leaks	Level/Leaks	Leaks
Other oils and fluids*	Level	Leaks	Level	
Fuel	Leaks	Leaks	Leaks	
Exhaust gas	—	Leaks	—	

*Power steering fluid, brake fluid, etc.

THERMOSTAT AND THERMOSTAT HOUSING

< REMOVAL AND INSTALLATION >

[VQ35DE]

THERMOSTAT AND THERMOSTAT HOUSING

Exploded View

INFOID:000000009135591

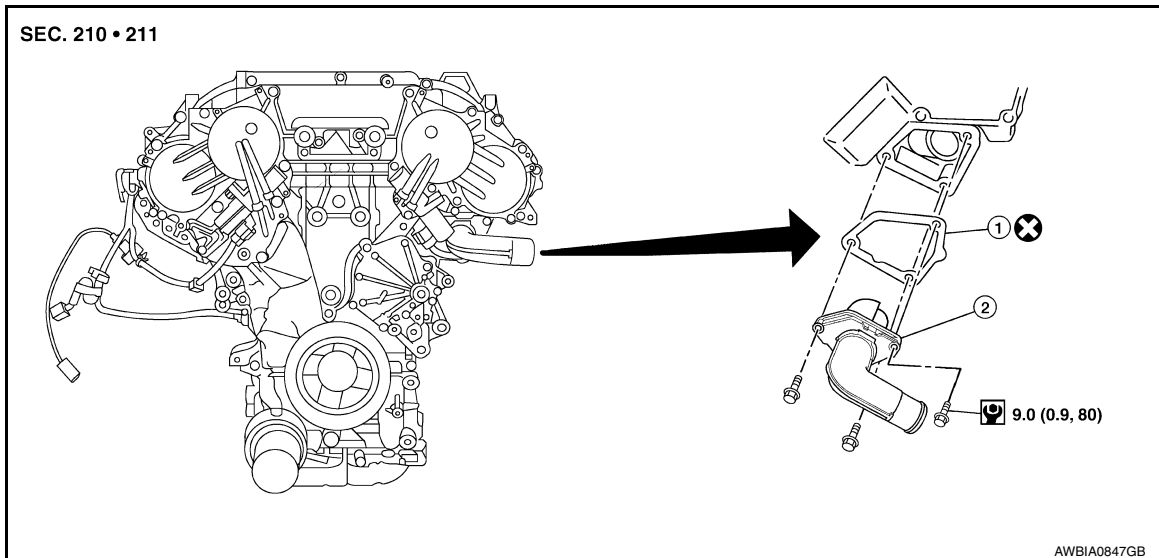

1. Gasket

2. Thermostat assembly (water inlet)

Removal and Installation

INFOID:000000009135592

WARNING:

Do not remove the radiator cap when the engine is hot. Serious burns could occur from high pressure engine coolant escaping from the radiator. Wrap a thick cloth around the cap. Slowly turn it a quarter of a turn to release built-up pressure. Carefully remove radiator cap by turning it all the way.

CAUTION:

- Perform when engine is cold.
- Do not spill engine coolant on the drive belt.
- Do not spill engine oil on rubber parts such as the drive belt or engine mount insulators.

NOTE:

When removing components such as hoses, tubes/lines, etc., cap or plug openings to prevent fluid from spilling.

REMOVAL

1. Drain engine coolant from radiator. Refer to [CO-11, "Changing Engine Coolant"](#).
2. Disconnect coolant reservoir hose and remove coolant reservoir tank.
3. Remove front under cover. Refer to [EXT-16, "Exploded View"](#).
4. Disconnect intake valve timing control solenoid valve (LH) harness connector.
5. Remove the lower radiator hose.
6. Remove thermostat assembly (water inlet).
 - Do not disassemble thermostat assembly (water inlet). Replace as a unit, (if necessary).

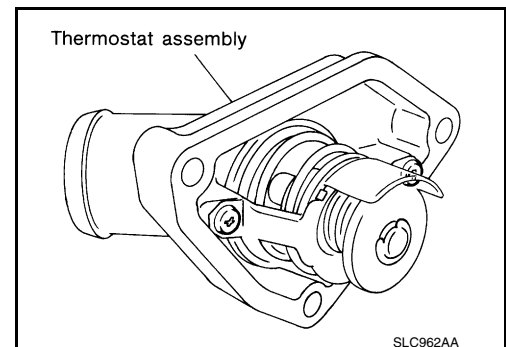

INSPECTION AFTER REMOVAL

THERMOSTAT AND THERMOSTAT HOUSING

[VQ35DE]

< REMOVAL AND INSTALLATION >

- Place a thread so that it is caught in the valves of the thermostat. Immerse fully in a container filled with water. Heat while stirring.
- The valve opening temperature is the temperature at which the valve opens and the thermostat falls from the thread.
- Continue heating. Check the full-open lift amount.

NOTE:

The full-open lift amount standard temperature for the thermostat is the reference value.

- After checking the full-open lift amount, lower the water temperature and check the valve closing temperature.

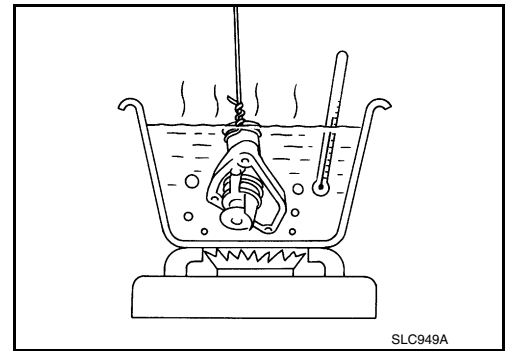

Thermostat	Standard Values
Valve opening temperature	Refer to CO-28. "Thermostat"
Full-open lift amount	Refer to CO-28. "Thermostat"
Valve closing temperature	Refer to CO-28. "Thermostat"

- If thermostat values are out of standard range, replace water inlet and thermostat assembly.

INSTALLATION

Installation is in the reverse order of removal.

- After installation, refill engine coolant and check for leaks. Refer to [CO-11. "Changing Engine Coolant"](#) and [CO-10. "System Inspection"](#).

CAUTION:

Do not spill engine coolant in engine compartment. Use a shop cloth to absorb engine coolant.

WATER OUTLET AND WATER PIPING

< REMOVAL AND INSTALLATION >

[VQ35DE]

WATER OUTLET AND WATER PIPING

Exploded View

INFOID:000000009135593

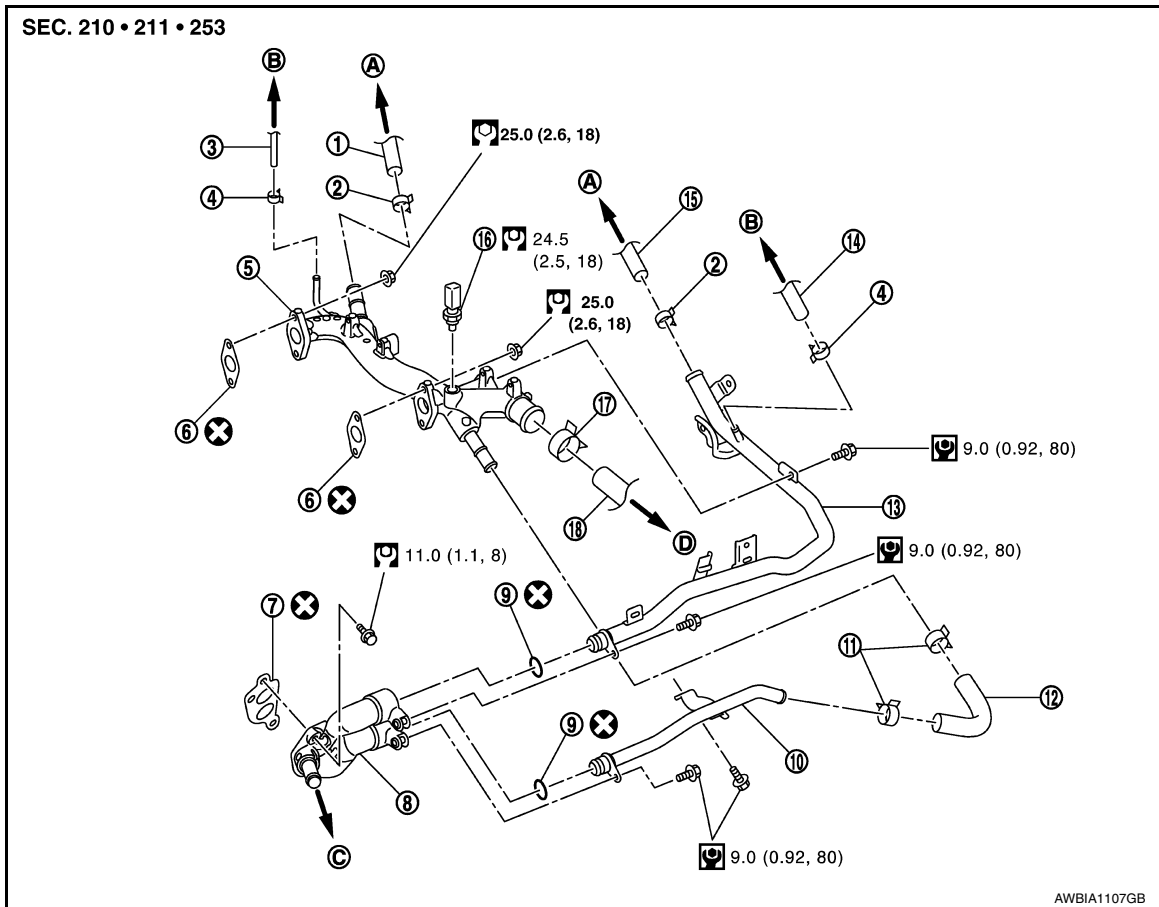

- | | | |
|---------------------------------------|------------------------------------------|---------------------------|
| 1. Heater hose | 2. Clamp | 3. Water hose |
| 4. Clamp | 5. Water outlet | 6. Gasket |
| 7. Gasket | 8. Water connector | 9. O-ring |
| 10. Water bypass pipe | 11. Clamp | 12. Water hose |
| 13. Heater pipe | 14. Water hose | 15. Heater hose |
| 16. Engine coolant temperature sensor | 17. Clamp | 18. Radiator hose (upper) |
| A. To heater core | B. To electric throttle control actuator | C. To CVT oil warmer |
| D. To radiator | | |

Removal and Installation

INFOID:000000009135594

WARNING:

Do not remove the radiator cap when the engine is hot. Serious burns could occur from high pressure engine coolant escaping from the radiator. Wrap a thick cloth around the cap. Slowly turn it a quarter of a turn to release built-up pressure. Carefully remove radiator cap by turning it all the way.

NOTE:

When removing components such as hoses, tubes/lines, etc., cap or plug openings to prevent fluid from spilling.

REMOVAL

CAUTION:

Perform when the engine is cold.

1. Remove engine room cover. Refer to [EM-23. "Removal and Installation"](#)
2. Partially drain engine coolant from radiator. Refer to [CO-11. "Changing Engine Coolant"](#).

WATER OUTLET AND WATER PIPING

[VQ35DE]

< REMOVAL AND INSTALLATION >

3. Remove front air duct and air cleaner case assembly. Refer to [EM-24, "Removal and Installation"](#).
4. Remove the electric throttle control actuator engine coolant hoses.
5. Remove radiator hose (upper) and both heater hoses.
6. Remove connector(s) from heater pipe.
7. Remove engine coolant temperature sensor on water outlet.
8. Remove water outlet, heater pipe, water connector, and water bypass pipe nuts and bolts.

A

CO

INSTALLATION

1. Installation is in the reverse order of removal.
 - Securely insert each hose, and install a clamp at a position where it does not interfere with the pipe bulge.

CAUTION:

Do not reuse gasket.

- When inserting heater pipe and water bypass pipe into water connector, apply mild soap to new O-rings.

CAUTION:

Do not reuse O-rings.

- After installation, refill engine coolant and check for leaks. Refer to [CO-11, "Changing Engine Coolant"](#) and [CO-10, "System Inspection"](#).

C

D

E

F

G

H

I

J

K

L

M

N

O

P

SERVICE DATA AND SPECIFICATIONS (SDS)

< SERVICE DATA AND SPECIFICATIONS (SDS)

[VQ35DE]

SERVICE DATA AND SPECIFICATIONS (SDS)

SERVICE DATA AND SPECIFICATIONS (SDS)

Capacity

INFOID:000000009135595

ℓ (US qt, Imp qt)

Engine coolant capacity*	9.6 (10-1/8, 8-1/2)
--------------------------	---------------------

*: Includes 0.75L with coolant reservoir tank at MAX level.

Thermostat

INFOID:000000009135596

Valve opening temperature	82°C (180°F)
Full-open lift amount	8.6 mm / 95°C (0.339 in / 203°F)
Valve closing temperature	77°C (171°F)

Radiator

INFOID:000000009135597

Unit: kPa (kg/cm², psi)

Cap relief pressure	Standard	88 (0.9, 12.8)
Test pressure		157 (1.6, 23)