

SECTION BR
BRAKE SYSTEM

A
B
C
D
E

CONTENTS

PRECAUTION	3	BRAKE MASTER CYLINDER	14	BR
PRECAUTIONS	3	Inspection	14	
Precaution for Supplemental Restraint System (SRS) "AIR BAG" and "SEAT BELT PRE-TENSIONER"	3	BRAKE BOOSTER	15	G
Precaution for Procedure without Cowl Top Cover.....	3	Inspection	15	
Precaution for Brake System	3	FRONT DISC BRAKE	16	H
Precautions for Removing Battery Terminal	4	BRAKE PAD	16	
PREPARATION	5	BRAKE PAD : Inspection and Adjustment	16	
PREPARATION	5	DISC ROTOR	16	I
Commercial Service Tool	5	DISC ROTOR : Inspection and Adjustment	16	
BASIC INSPECTION	6	REAR DISC BRAKE	18	J
FRONT DISC BRAKE	6	BRAKE PAD	18	
DISC ROTOR	6	BRAKE PAD : Inspection and Adjustment	18	K
DISC ROTOR : Inspection	6	DISC ROTOR	18	
REAR DISC BRAKE	7	DISC ROTOR : Inspection and Adjustment	18	L
DISC ROTOR	7	REMOVAL AND INSTALLATION	20	
DISC ROTOR : Inspection	7	BRAKE PEDAL	20	M
SYMPTOM DIAGNOSIS	8	Exploded View	20	
NOISE, VIBRATION AND HARSHNESS (NVH) TROUBLESHOOTING	8	Removal and Installation	20	
NVH Troubleshooting Chart	8	Inspection and Adjustment	21	
PERIODIC MAINTENANCE	9	BRAKE PIPING	22	N
BRAKE PEDAL	9	FRONT	22	
Inspection and Adjustment	9	FRONT : Exploded View	22	O
BRAKE FLUID	12	FRONT : Hydraulic Piping	23	
Inspection	12	FRONT : Removal and Installation	24	
Draining	12	FRONT : Inspection	26	P
Refilling	12	REAR	26	
Bleeding Brake System	13	REAR : Exploded View	26	
		REAR : Hydraulic Piping	28	
		REAR : Removal and Installation	29	
		REAR : Inspection	30	
		BRAKE MASTER CYLINDER	31	

Exploded View	31	BRAKE CALIPER ASSEMBLY (4 PISTON TYPE)	
Removal and Installation	32	: Inspection	53
Disassembly and Assembly	33	REAR DISC BRAKE	54
Inspection	34	BRAKE PAD (1 PISTON TYPE)	54
BRAKE BOOSTER	35	BRAKE PAD (1 PISTON TYPE) : Exploded View...	54
Exploded View	35	BRAKE PAD (1 PISTON TYPE) : Removal and In-	54
Removal and installation	35	stallation	54
Inspection and Adjustment	36	BRAKE PAD (1 PISTON TYPE) : Inspection	55
VACUUM LINES	39	BRAKE PAD (2 PISTON TYPE)	55
Exploded View	39	BRAKE PAD (2 PISTON TYPE) : Exploded View...	56
Removal and Installation	40	BRAKE PAD (2 PISTON TYPE) : Removal and In-	56
Inspection	40	stallation	56
FRONT DISC BRAKE	41	BRAKE PAD (2 PISTON TYPE) : Inspection	58
BRAKE PAD (2 PISTON TYPE)	41	BRAKE CALIPER ASSEMBLY (1 PISTON TYPE)... 58	
BRAKE PAD (2 PISTON TYPE) : Exploded View...	41	BRAKE CALIPER ASSEMBLY (1 PISTON TYPE)	
BRAKE PAD (2 PISTON TYPE) : Removal and In-	42	: Exploded View	58
stallation	42	BRAKE CALIPER ASSEMBLY (1 PISTON TYPE)	
BRAKE PAD (2 PISTON TYPE) : Inspection	43	: Removal and Installation	59
BRAKE PAD (4 PISTON TYPE)	43	BRAKE CALIPER ASSEMBLY (1 PISTON TYPE)	
BRAKE PAD (4 PISTON TYPE) : Exploded View...	43	: Disassembly and Assembly	60
BRAKE PAD (4 PISTON TYPE) : Removal and In-	44	BRAKE CALIPER ASSEMBLY (1 PISTON TYPE)	
stallation	44	: Inspection	62
BRAKE PAD (4 PISTON TYPE) : Inspection	45	BRAKE CALIPER ASSEMBLY (2 PISTON TYPE)... 63	
BRAKE CALIPER ASSEMBLY (2 PISTON TYPE)... 45		BRAKE CALIPER ASSEMBLY (2 PISTON TYPE)	
BRAKE CALIPER ASSEMBLY (2 PISTON TYPE)		: Exploded View	63
: Exploded View	45	BRAKE CALIPER ASSEMBLY (2 PISTON TYPE)	
BRAKE CALIPER ASSEMBLY (2 PISTON TYPE)		: Removal and Installation	64
: Removal and Installation	46	BRAKE CALIPER ASSEMBLY (2 PISTON TYPE)	
BRAKE CALIPER ASSEMBLY (2 PISTON TYPE)		: Disassembly and Assembly	65
: Disassembly and Assembly	47	BRAKE CALIPER ASSEMBLY (2 PISTON TYPE)	
BRAKE CALIPER ASSEMBLY (2 PISTON TYPE)		: Inspection	66
: Inspection	49	SERVICE DATA AND SPECIFICATIONS	
BRAKE CALIPER ASSEMBLY (4 PISTON TYPE)... 49		(SDS)	67
BRAKE CALIPER ASSEMBLY (4 PISTON TYPE)		SERVICE DATA AND SPECIFICATIONS	
: Exploded View	49	(SDS)	67
BRAKE CALIPER ASSEMBLY (4 PISTON TYPE)		General Specifications	67
: Removal and Installation	50	Brake Pedal	68
BRAKE CALIPER ASSEMBLY (4 PISTON TYPE)		Brake Booster	68
: Disassembly and Assembly	51	Front Disc Brake	68
		Rear Disc Brake	69

PRECAUTIONS

< PRECAUTION >

PRECAUTION

PRECAUTIONS

Precaution for Supplemental Restraint System (SRS) "AIR BAG" and "SEAT BELT PRE-TENSIONER"

INFOID:000000010585112

The Supplemental Restraint System such as "AIR BAG" and "SEAT BELT PRE-TENSIONER", used along with a front seat belt, helps to reduce the risk or severity of injury to the driver and front passenger for certain types of collision. This system includes seat belt switch inputs and dual stage front air bag modules. The SRS system uses the seat belt switches to determine the front air bag deployment, and may only deploy one front air bag, depending on the severity of a collision and whether the front occupants are belted or unbelted. Information necessary to service the system safely is included in the "SRS AIR BAG" and "SEAT BELT" of this Service Manual.

WARNING:

Always observe the following items for preventing accidental activation.

- To avoid rendering the SRS inoperative, which could increase the risk of personal injury or death in the event of a collision that would result in air bag inflation, all maintenance must be performed by an authorized NISSAN/INFINITI dealer.
- Improper maintenance, including incorrect removal and installation of the SRS, can lead to personal injury caused by unintentional activation of the system. For removal of Spiral Cable and Air Bag Module, see "SRS AIR BAG".
- Never use electrical test equipment on any circuit related to the SRS unless instructed to in this Service Manual. SRS wiring harnesses can be identified by yellow and/or orange harnesses or harness connectors.

PRECAUTIONS WHEN USING POWER TOOLS (AIR OR ELECTRIC) AND HAMMERS

WARNING:

Always observe the following items for preventing accidental activation.

- When working near the Air Bag Diagnosis Sensor Unit or other Air Bag System sensors with the ignition ON or engine running, never use air or electric power tools or strike near the sensor(s) with a hammer. Heavy vibration could activate the sensor(s) and deploy the air bag(s), possibly causing serious injury.
- When using air or electric power tools or hammers, always switch the ignition OFF, disconnect the battery, and wait at least 3 minutes before performing any service.

Precaution for Procedure without Cowl Top Cover

INFOID:000000010585113

When performing the procedure after removing cowl top cover, cover the lower end of windshield with urethane, etc to prevent damage to windshield.

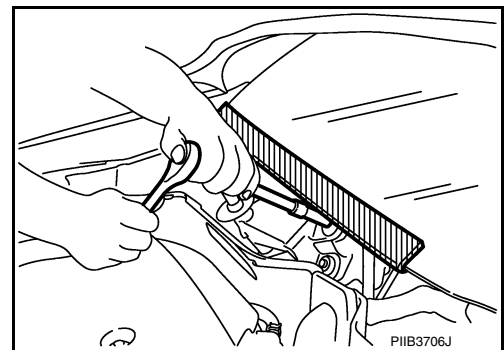

Precaution for Brake System

INFOID:000000010585114

WARNING:

Since dust covering the front and rear brakes has an affect on human body, the dust must be removed with a dust collector. Never splatter the dust with an air blow gun.

CAUTION:

- Brake fluid use refer to [MA-17, "FOR NORTH AMERICA : Fluids and Lubricants"](#) (except for Mexico), [MA-18, "FOR MEXICO : Fluids and Lubricants"](#) (for Mexico).
- Never reuse drained brake fluid.

PRECAUTIONS

< PRECAUTION >

- Never spill or splash brake fluid on painted surfaces. Brake fluid may seriously damage paint. Wipe it off immediately and wash with water if it gets on a painted surface.
- After pressing the brake pedal more deeply or harder than normal driving, such as air bleeding, check each item of brake pedal. Adjust brake pedal if it is outside the standard value.
- Always clean with new brake fluid when cleaning the master cylinder, brake caliper and other components.
- Never use mineral oils such as gasoline or light oil to clean. They may damage rubber parts and cause improper operation.
- Always loosen the brake tube flare nut with a flare nut wrench.
- Tighten the brake tube flare nut to the specified torque with a crowfoot (A) and torque wrench (B).
- Always confirm the specified tightening torque when installing the brake pipes.
- Turn the ignition switch OFF and disconnect the ABS actuator and electric unit (control unit) connector or the battery negative terminal before performing the work.
- Check that no brake fluid leakage is present after replacing the parts.
- Burnish the brake contact surfaces after refinishing or replacing rotors, after replacing pads, or if a soft pedal occurs at very low mileage.
- Front brake pad: Refer to [BR-16, "BRAKE PAD : Inspection and Adjustment"](#).
- Front disc rotor: Refer to [BR-16, "DISC ROTOR : Inspection and Adjustment"](#).
- Rear brake pad: Refer to [BR-18, "BRAKE PAD : Inspection and Adjustment"](#).
- Rear disc rotor: Refer to [BR-18, "DISC ROTOR : Inspection and Adjustment"](#).

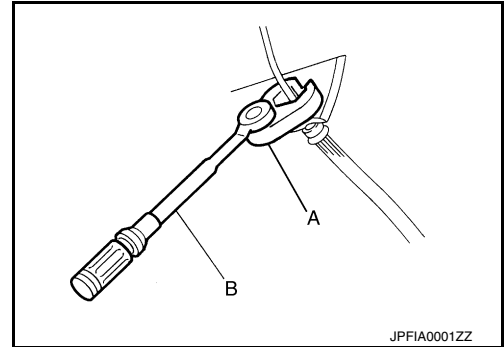

Precautions for Removing Battery Terminal

INFOID:000000010951664

- When removing the 12V battery terminal, turn OFF the ignition switch and wait at least 30 seconds.

NOTE:

ECU may be active for several tens of seconds after the ignition switch is turned OFF. If the battery terminal is removed before ECU stops, then a DTC detection error or ECU data corruption may occur.

- For vehicles with the 2-batteries, be sure to connect the main battery and the sub battery before turning ON the ignition switch.

NOTE:

If the ignition switch is turned ON with any one of the terminals of main battery and sub battery disconnected, then DTC may be detected.

- After installing the 12V battery, always check "Self Diagnosis Result" of all ECUs and erase DTC.

NOTE:

The removal of 12V battery may cause a DTC detection error.

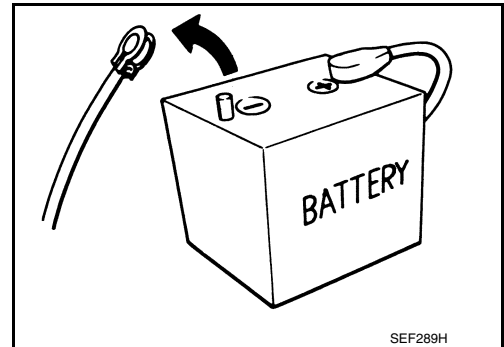

PREPARATION

< PREPARATION >

PREPARATION

PREPARATION

Commercial Service Tool

INFOID:000000010585115

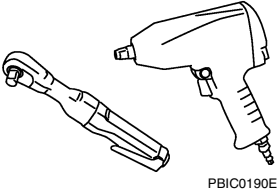
Tool name	Description
<p data-bbox="164 411 277 441">Power tool</p>  <p data-bbox="870 632 943 646">PBIC0190E</p>	<p data-bbox="1068 411 1321 441">Loosening bolts and nuts</p>

A

B

C

D

E

BR

G

H

I

J

K

L

M

N

O

P

FRONT DISC BRAKE

< BASIC INSPECTION >

BASIC INSPECTION

FRONT DISC BRAKE

DISC ROTOR

DISC ROTOR : Inspection

INFOID:0000000010951640

INSPECTION

Uneven wear

Check the uneven wear of the disc rotor using a micrometer. Replace the disc rotor if the thickness is below the wear limit. Refer to [FAX-7, "Removal and Installation"](#) (2WD) and [FAX-17, "Removal and Installation"](#) (AWD).

Thickness variation : Refer to [BR-68, "Front Disc Brake"](#).
(measured at 8 positions)

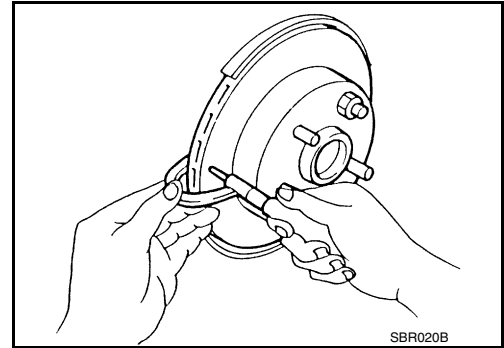

REAR DISC BRAKE

< BASIC INSPECTION >

REAR DISC BRAKE

DISC ROTOR

DISC ROTOR : Inspection

INFOID:000000010951641

INSPECTION

Uneven wear

Check the uneven wear of the disc rotor using a micrometer. Replace the disc rotor if the thickness is below the wear limit. Refer to [FAX-7, "Removal and Installation"](#) (2WD) [FAX-17, "Removal and Installation"](#) (AWD).

Thickness variation (measured at 8 positions) : Refer to [BR-69, "Rear Disc Brake"](#).

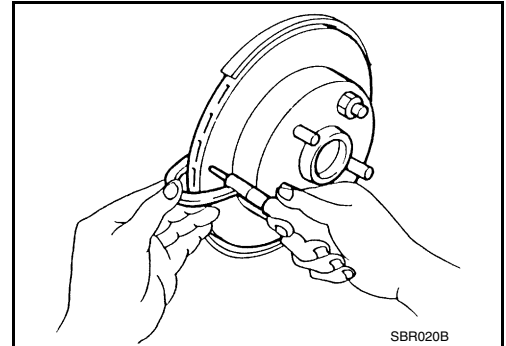

A

B

C

D

E

BR

G

H

I

J

K

L

M

N

O

P

NOISE, VIBRATION AND HARSHNESS (NVH) TROUBLESHOOTING

< SYMPTOM DIAGNOSIS >

SYMPTOM DIAGNOSIS

NOISE, VIBRATION AND HARSHNESS (NVH) TROUBLESHOOTING

NVH Troubleshooting Chart

INFOID:000000010585111

Use the chart below to find the cause of the symptom. If necessary, repair or replace these parts.

Symptom	BRAKE	Possible cause and SUSPECTED PARTS													Reference page					
		Pads - damaged	Pads - uneven wear	Shims damaged	Rotor imbalance	Rotor damage	Rotor runout	Rotor deformation	Rotor deflection	Rotor rust	Rotor thickness variation	Drum out of round	PROPELLER SHAFT	DIFFERENTIAL		AXLE AND SUSPENSION	TIRE	ROAD WHEEL	DRIVE SHAFT	STEERING
	Noise	x	x	x																BR-16, BR-18
	Shake				x															BR-16, BR-18
	Shimmy, Judder				x	x	x	x	x	x										BR-43, BR-45, BR-55, BR-58
																				BR-16, BR-18, BR-6, BR-7
																				BR-16, BR-18, BR-6, BR-7
																				BR-16, BR-18
																				BR-16, BR-18
																				BR-16, BR-18, BR-6, BR-7
																				NVH in PB section
																				NVH in DLN section
																				NVH in DLN section
																				NVH in FAX, RAX and FSU, RSU section
																				NVH in WT section
																				NVH in WT section
																				NVH in FAX and/or RAX section
																				NVH in ST section

x: Applicable

BRAKE PEDAL

< PERIODIC MAINTENANCE >

PERIODIC MAINTENANCE

BRAKE PEDAL

Inspection and Adjustment

INFOID:000000010585116

INSPECTION

Brake Pedal Height

Check the brake pedal height (H_1) between the dash lower panel (1) and the brake pedal upper surface.

Standard

H_1 : Refer to [BR-68, "Brake Pedal"](#).

CAUTION:

Remove the floor trim.

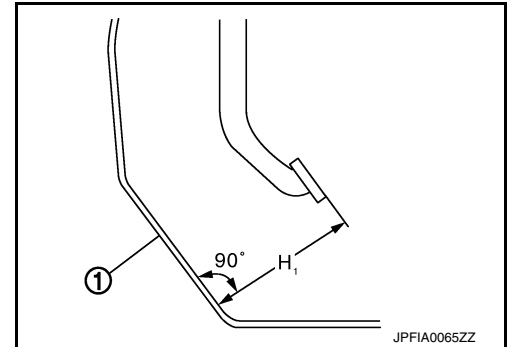

Stop Lamp Switch and ASCD Brake Switch

Check the clearance (C) between stopper rubber (1) and stop lamp switch and ASCD brake switch (2) threaded end.

Standard

C : Refer to [BR-68, "Brake Pedal"](#).

CAUTION:

The stop lamp must be turned off when the brake pedal is released.

NOTE:

Pull the brake pedal pad to make the clearance between stopper rubber and stop lamp switch and ASCD brake switch threaded end.

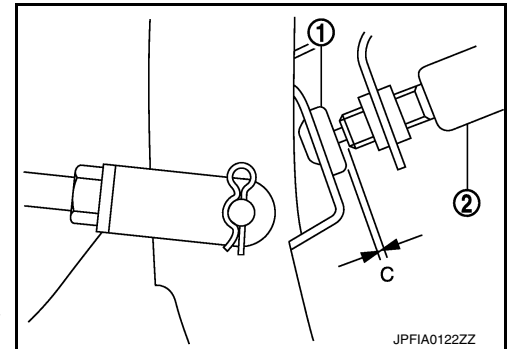

Brake Pedal Play

Press the brake pedal. Check the brake pedal play (A).

Standard

A : Refer to [BR-68, "Brake Pedal"](#).

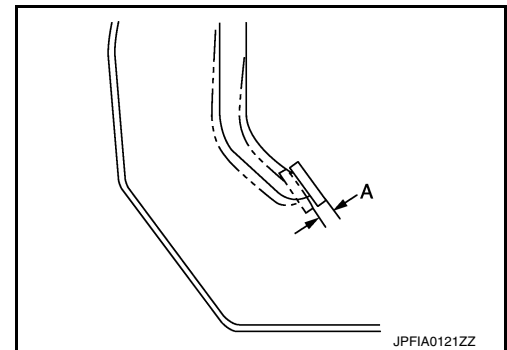

Depressed Brake Pedal Height

Check the brake pedal height (H_2) between the dash lower panel (1) and the brake pedal upper surface when depressing the brake pedal at 490 N (50 kg, 110 lb) while turning engine ON.

Standard

H_2 : Refer to [BR-68, "Brake Pedal"](#).

CAUTION:

Remove the floor trim.

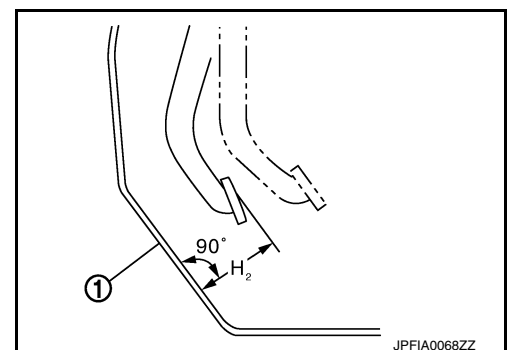

A
B
C
D
E
BR
G
H
I
J
K
L
M
N
O
P

BRAKE PEDAL

< PERIODIC MAINTENANCE >

ADJUSTMENT

Brake Pedal Height

1. Remove instrument lower panel LH. Refer to [IP-12, "Exploded View"](#).
2. Disconnect the stop lamp switch and ASCD brake switch harness connector.
3. Turn the stop lamp switch and ASCD brake switch 45° counterclockwise.
4. Loosen the input rod lock nut (1). Adjust the brake pedal height (H_1) to the specification. Tighten the input rod lock nut to the specification. Refer to [BR-35, "Exploded View"](#).

CAUTION:

The threaded end of the input rod (2) must project to the inner side (L) of the clevis (3).

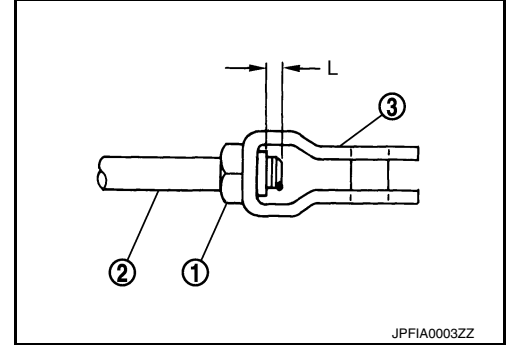

Standard

H_1 : Refer to [BR-68, "Brake Pedal"](#).

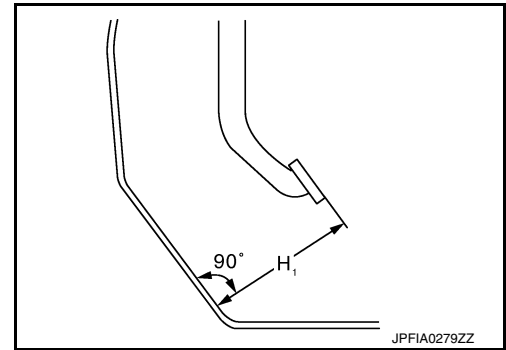

Stop Lamp Switch and ASCD Brake Switch

1. Remove instrument lower panel LH. Refer to [IP-12, "Exploded View"](#).
2. Disconnect the stop lamp switch and ASCD brake switch harness connector.
3. Turn the stop lamp switch and ASCD brake switch 45° counterclockwise.
4. Press-fit stop lamp switch and ASCD brake switch (2) until stop lamp switch and ASCD brake switch hits the stopper rubber (1) 45° clockwise.

CAUTION:

- The clearance (C) between the stopper rubber and stop lamp switch and ASCD brake switch threaded end must be the specified value. Refer to [BR-68, "Brake Pedal"](#).
- The stop lamp must be turned off when the brake pedal is released.

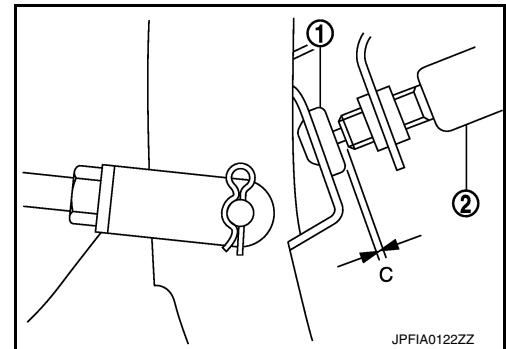

Brake Pedal Play

1. Remove instrument lower panel LH. Refer to [IP-12, "Exploded View"](#).
2. Disconnect the stop lamp switch and ASCD brake switch harness connector.
3. Turn the stop lamp switch and ASCD brake switch 45° counterclockwise.

BRAKE PEDAL

< PERIODIC MAINTENANCE >

4. Press-fit stop lamp switch and ASCD brake switch (2) until stop lamp switch and ASCD brake switch hits the stopper rubber (1) 45° clockwise.

CAUTION:

- The clearance (C) between the stopper rubber and stop lamp switch and ASCD brake switch threaded end must be the specified value. Refer to [BR-68. "Brake Pedal"](#).
- The stop lamp must be turned off when the brake pedal is released.

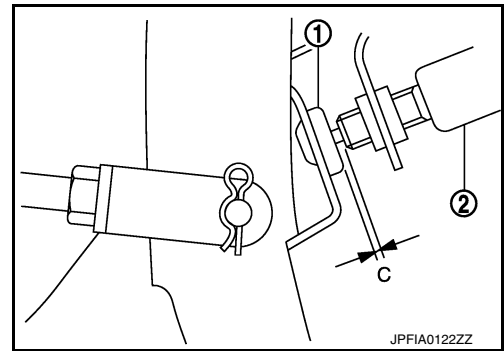

A
B
C
D
E
F
G
H
I
J
K
L
M
N
O
P

BR

BRAKE FLUID

< PERIODIC MAINTENANCE >

BRAKE FLUID

Inspection

INFOID:000000010585117

BRAKE FLUID LEVEL

- Check that the fluid level in the reservoir tank is within the specified range (MAX – MIN lines).
- Visually check for any brake fluid leakage around the reservoir tank.
- Check the brake system for any leakage if the fluid level is extremely low (lower than MIN).
- Check the brake system for fluid leakage if the warning lamp remains illuminated even after the parking brake is released.

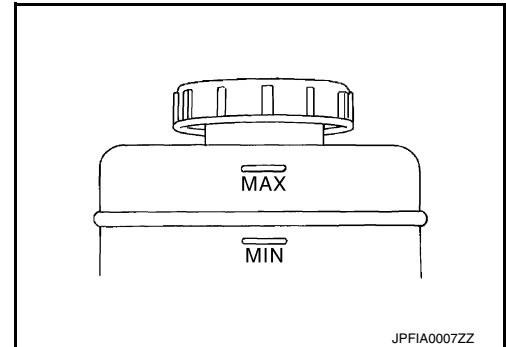

BRAKE LINE

1. Check brake line (tubes and hoses) for cracks, deterioration or other damage. Replace any damaged parts.
2. Check for fluid leakage by fully depressing brake pedal while engine is running.

CAUTION:

If leakage occurs around joints, retighten or, if necessary, replace damaged parts.

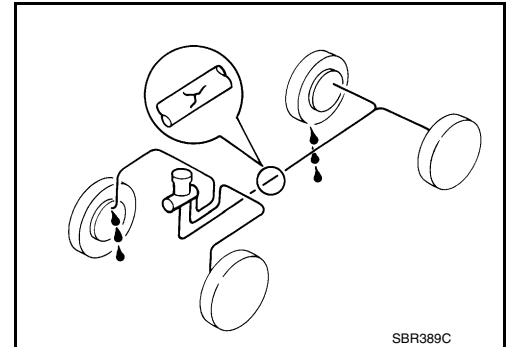

Draining

INFOID:000000010585118

CAUTION:

- **Never spill or splash brake fluid on painted surfaces. Brake fluid may seriously damage paint. Wipe it off immediately and wash with water if it gets on a painted surface.**
- **Turn the ignition switch OFF and disconnect the ABS actuator and electric unit (control unit) connector or the battery negative terminal before performing work.**

1. Connect a vinyl tube to the bleed valve.
2. Depress the brake pedal and loosen the bleeder valve to gradually discharge brake fluid.

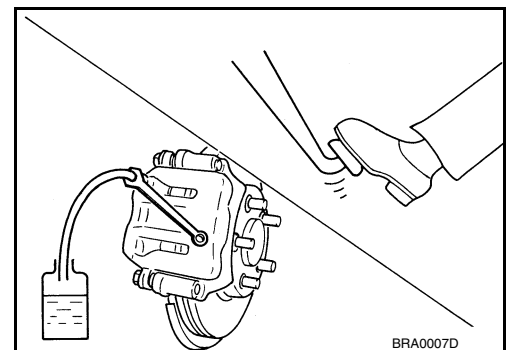

Refilling

INFOID:000000010585119

CAUTION:

Turn the ignition switch OFF and disconnect the ABS actuator and electric unit (control unit) connector or the battery negative terminal before performing work.

1. Check that there is no foreign material in the reservoir tank, and refill with new brake fluid.

CAUTION:

Never reuse drained brake fluid.

BRAKE FLUID

< PERIODIC MAINTENANCE >

2. Loosen the bleeder valve, slowly depress the brake pedal to the full stroke, and then release the pedal. Repeat this operation at intervals of 2 or 3 seconds until new brake fluid is discharged. Then close the bleeder valve with the brake pedal depressed. Repeat the same work on each wheel. A
3. Perform the air bleeding. Refer to [BR-13. "Bleeding Brake System"](#). B

Bleeding Brake System

INFOID:000000010585120

CAUTION:

- Turn the ignition switch OFF and disconnect the ABS actuator and electric unit (control unit) connector or the battery negative terminal before performing the work. C
 - Monitor the fluid level in the reservoir tank while performing the air bleeding D
 - Always use new brake fluid for refilling. Never reuse the drained brake fluid. E
1. Connect a vinyl tube to the bleeder valve of the rear right brake. BR
 2. Fully depress the brake pedal 4 to 5 times.
 3. Loosen the bleeder valve and bleed air with the brake pedal depressed, and then quickly tighten the bleeder valve.
 4. Repeat steps 2 and 3 until all of the air is out of the brake line.
 5. Tighten the bleeder valve to the specified torque. G
 - Front disc brake: refer to [BR-45. "BRAKE CALIPER ASSEMBLY \(2 PISTON TYPE\) : Exploded View"](#) (2 piston type), [BR-49. "BRAKE CALIPER ASSEMBLY \(4 PISTON TYPE\) : Exploded View"](#) (4 piston type).
 - Rear disc brake: refer to [BR-58. "BRAKE CALIPER ASSEMBLY \(1 PISTON TYPE\) : Exploded View"](#) (1 piston type), [BR-63. "BRAKE CALIPER ASSEMBLY \(2 PISTON TYPE\) : Exploded View"](#) (2 piston type).
 6. Perform steps 1 to 5 for the rear right brake → front left brake → rear left brake → and front right brake in order. H
 7. Check that the fluid level in the reservoir tank is within the specified range after air bleeding. Refer to [BR-12. "Inspection"](#). I
 8. Check each item of brake pedal. Adjust it if the measurement value is not the standard. Refer to [BR-9. "Inspection and Adjustment"](#). J
- K
L
M
N
O
P

BRAKE MASTER CYLINDER

< PERIODIC MAINTENANCE >

BRAKE MASTER CYLINDER

Inspection

INFOID:000000010585121

FLUID LEAK

Check for brake fluid leakage from the master cylinder mounting face, reservoir tank mounting face and brake tube connections.

BRAKE BOOSTER

< PERIODIC MAINTENANCE >

BRAKE BOOSTER

Inspection

INFOID:000000010585122

OPERATION

Depress the brake pedal several times at 5-second intervals with the engine stopped. Start the engine with the brake pedal fully depressed. Check that the clearance between brake pedal and dash lower panel decreases.

NOTE:

A slight impact with a small click may be felt on the pedal when the brake pedal is fully depressed. This is a normal phenomenon due to the brake system operation.

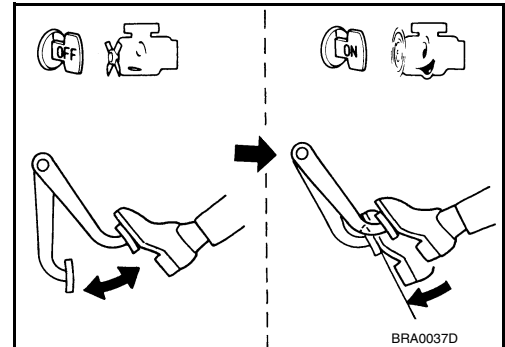

AIR TIGHT

- Idle the engine for 1 minute to apply vacuum to the brake booster, and stop the engine. Then depress the brake pedal several times at 5-second intervals until the accumulated vacuum is released to atmospheric pressure. Check that the clearance between brake pedal and dash lower panel gradually increases (A → B → C) each time the brake pedal is depressed during this operation.

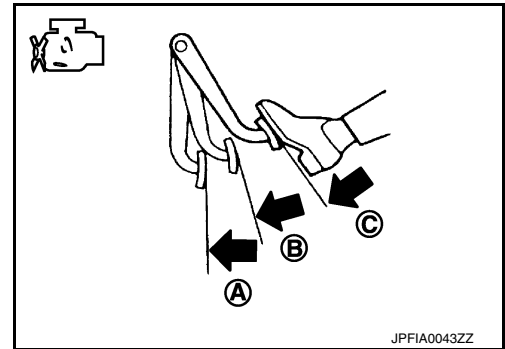

- Depress the brake pedal with the engine running. Then stop the engine while holding down the brake pedal. Check that the brake pedal stroke does not change after holding down the brake pedal for 30 seconds or more.

NOTE:

A slight impact with a small click may be felt on the pedal when the brake pedal is fully depressed. This is a normal phenomenon due to the brake system operation.

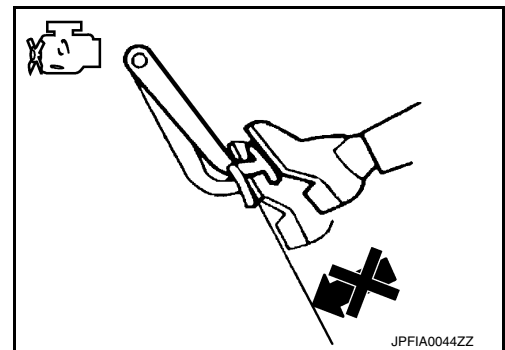

A
B
C
D
E
BR
G
H
I
J
K
L
M
N
O
P

FRONT DISC BRAKE

< PERIODIC MAINTENANCE >

FRONT DISC BRAKE

BRAKE PAD

BRAKE PAD : Inspection and Adjustment

INFOID:000000010585123

INSPECTION

2 Piston Type

Check brake pad wear thickness from an inspection hole on cylinder body. Check using a scale if necessary.

Limit

Wear thickness

: Refer to [BR-68, "Front Disc Brake"](#).

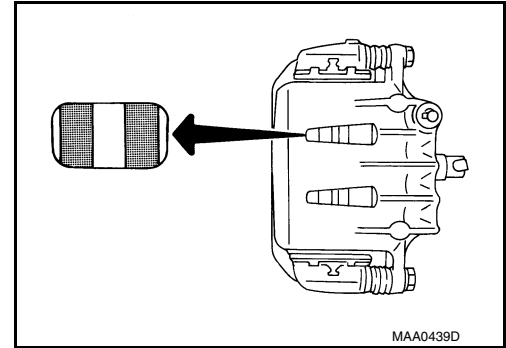

4 Piston Type

Check brake pad wear thickness from an inspection hole on caliper. Check using a scale if necessary.

Limit

Wear thickness

: Refer to [BR-68, "Front Disc Brake"](#).

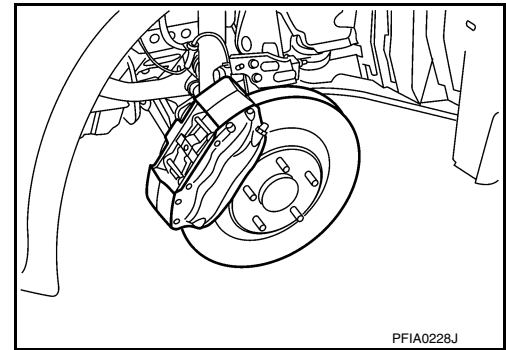

ADJUSTMENT

CAUTION:

- Burnish contact surfaces between pads according to the following procedure after refinishing or replacing pads, or if a soft pedal occurs at very low mileage.
- Be careful of vehicle speed because the brake does not operate firmly/securely until pads and disc rotor are securely fitted.
- Only perform this procedure under safe road and traffic conditions. Use extreme caution.

1. Drive vehicle on straight, flat road.
2. Depress brake pedal with the power to stop vehicle within 3 to 5 seconds until the vehicle stops.
3. Drive without depressing brake for a few minutes to cool the brake.
4. Repeat steps 1 to 3 until pad and disc rotor are securely fitted.

DISC ROTOR

DISC ROTOR : Inspection and Adjustment

INFOID:000000010585124

INSPECTION

Appearance

Check surface of disc rotor for uneven wear, cracks, and serious damage. Replace it if necessary.

Runout

FRONT DISC BRAKE

< PERIODIC MAINTENANCE >

1. Fix the disc rotor to the wheel hub and bearing assembly with wheel nuts (2 points at least).
2. Check the wheel bearing axial end play before the inspection. Refer to [FAX-6, "Inspection"](#) (2WD), [FAX-15, "Inspection"](#) (AWD).
3. Inspect the runout with a dial indicator to measure at 10 mm (0.39 in) inside the disc edge.

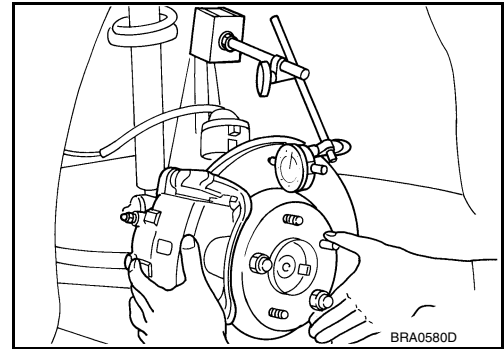

Limit

Runout : Refer to [BR-68, "Front Disc Brake"](#).

4. Find the installation position that has a minimum runout by shifting the disc rotor-to-wheel hub and bearing assembly installation position by one hole at a time if the runout exceeds the limit value.
5. Refinish the disc rotor if the runout is outside the limit even after performing the above operation. [When refinishing, use the Pro-Cut PEM On-Car brake Lathe (Tool No. 38-PFM90.5) or equivalent.]

CAUTION:

- Check in advance that the thickness of the disc rotor is wear thickness + 0.3 mm (0.012 in) or more.
- If the thickness is less than wear thickness + 0.3 mm (0.012 in), replace the disc rotor.

Limit

Wear thickness : Refer to [BR-68, "Front Disc Brake"](#).

Thickness

Check the thickness of the disc rotor using a micrometer. Replace the disc rotor if the thickness is below the wear limit.

Limit

Wear thickness : Refer to [BR-68, "Front Disc Brake"](#).

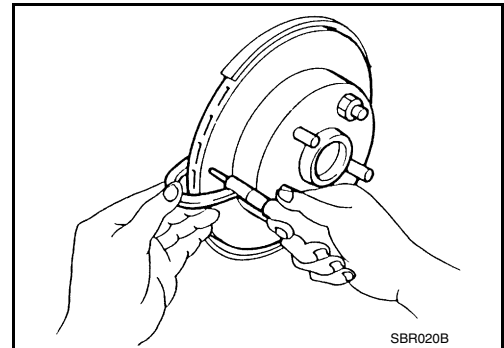

ADJUSTMENT

CAUTION:

- Burnish contact surfaces between disc rotors and pads according to the following procedure after refinishing or replacing disc rotor, or if a soft pedal occurs at very low mileage.
 - Be careful of vehicle speed because the brake does not operate firmly/securely until pad and disc rotor are securely fitted.
 - Only perform this procedure under safe road and traffic conditions. Use extreme caution.
1. Drive vehicle on straight, flat road.
 2. Depress brake pedal with the power to stop vehicle within 3 to 5 seconds until the vehicle stops.
 3. Drive without depressing brake for a few minutes to cool the brake.
 4. Repeat steps 1 to 3 until pad and disc rotor are securely fitted.

REAR DISC BRAKE

< PERIODIC MAINTENANCE >

REAR DISC BRAKE

BRAKE PAD

BRAKE PAD : Inspection and Adjustment

INFOID:000000010585125

INSPECTION

1 Piston Type

Check brake pad wear thickness from an inspection hole on cylinder body. Check using a scale if necessary.

Limit

Wear thickness : Refer to [BR-69, "Rear Disc Brake"](#).

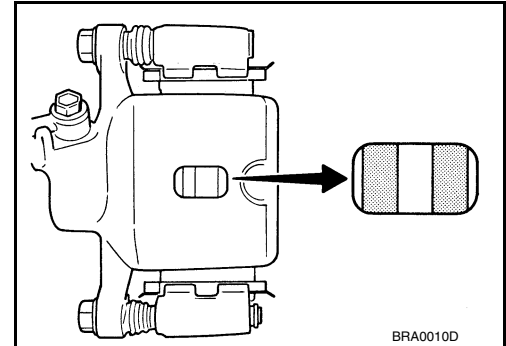

2 Piston Type

Check brake pad wear thickness from an inspection hole on caliper. Check using a scale if necessary.

Limit

Wear thickness : Refer to [BR-69, "Rear Disc Brake"](#).

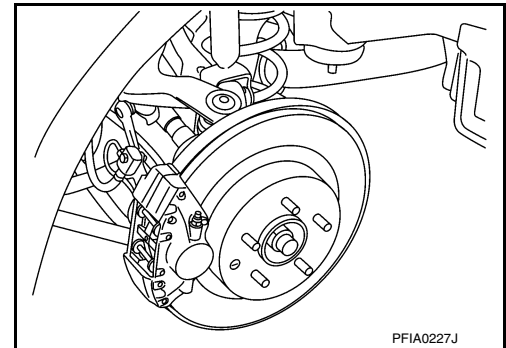

ADJUSTMENT

CAUTION:

- Burnish contact surfaces between pads according to the following procedure after refinishing or replacing pads, or if a soft pedal occurs at very low mileage.
- Be careful of vehicle speed because the brake does not operate firmly/securely until pads and disc rotor are securely fitted.
- Only perform this procedure under safe road and traffic conditions. Use extreme caution.

1. Drive vehicle on straight, flat road.
2. Depress brake pedal with the power to stop vehicle within 3 to 5 seconds until the vehicle stops.
3. Drive without depressing brake for a few minutes to cool the brake.
4. Repeat steps 1 to 3 until pad and disc rotor are securely fitted.

DISC ROTOR

DISC ROTOR : Inspection and Adjustment

INFOID:000000010585126

INSPECTION

Appearance

Check surface of disc rotor for uneven wear, cracks, and serious damage. Replace it if necessary.

Runout

REAR DISC BRAKE

< PERIODIC MAINTENANCE >

1. Fix the disc rotor to the wheel hub and bearing assembly with wheel nuts (2 points at least).
2. Check the wheel bearing axial end play before the inspection. Refer to [RAX-5, "Inspection"](#).
3. Inspect the runout with a dial indicator to measure at 10 mm (0.39 in) inside disc edge.

Limit

Runout : Refer to [BR-69, "Rear Disc Brake"](#).

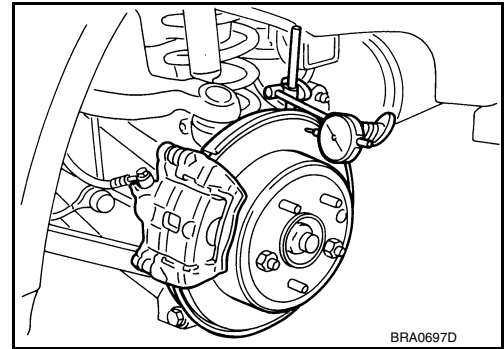

4. Find the installation position that has a minimum runout by shifting the disc rotor-to-wheel hub and bearing assembly installation position by one hole at a time if the runout exceeds the limit value.
5. Refinish the disc rotor if the runout is outside the limit even after performing the above operation. [When refinishing, use the Pro-Cut PEM On-Car brake Lathe (Tool No. 38-PFM90.5) or equivalent.]

CAUTION:

- Check in advance that the thickness of the disc rotor is wear thickness + 0.3 mm (0.012 in) or more.
- If the thickness is less than wear thickness + 0.3 mm (0.012 in), replace the disc rotor.

Limit

Wear thickness : Refer to [BR-69, "Rear Disc Brake"](#).

Thickness

Check the thickness of the disc rotor using a micrometer. Replace the disc rotor if the thickness is below the wear limit.

Limit

Wear thickness : Refer to [BR-69, "Rear Disc Brake"](#).

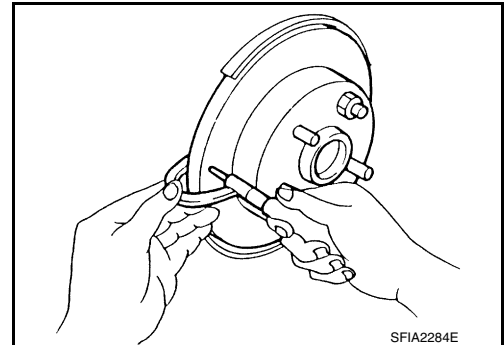

ADJUSTMENT

CAUTION:

- Burnish contact surfaces between disc rotors and pads according to the following procedure after refinishing or replacing disc rotor, or if a soft pedal occurs at very low mileage.
 - Be careful of vehicle speed because the brake does not operate firmly/securely until pad and disc rotor are securely fitted.
 - Only perform this procedure under safe road and traffic conditions. Use extreme caution.
1. Drive vehicle on straight, flat road.
 2. Depress brake pedal with the power to stop vehicle within 3 to 5 seconds until the vehicle stops.
 3. Drive without depressing brake for a few minutes to cool the brake.
 4. Repeat steps 1 to 3 until pad and disc rotor are securely fitted.

BRAKE PEDAL

< REMOVAL AND INSTALLATION >

REMOVAL AND INSTALLATION

BRAKE PEDAL

Exploded View

INFOID:0000000010585127

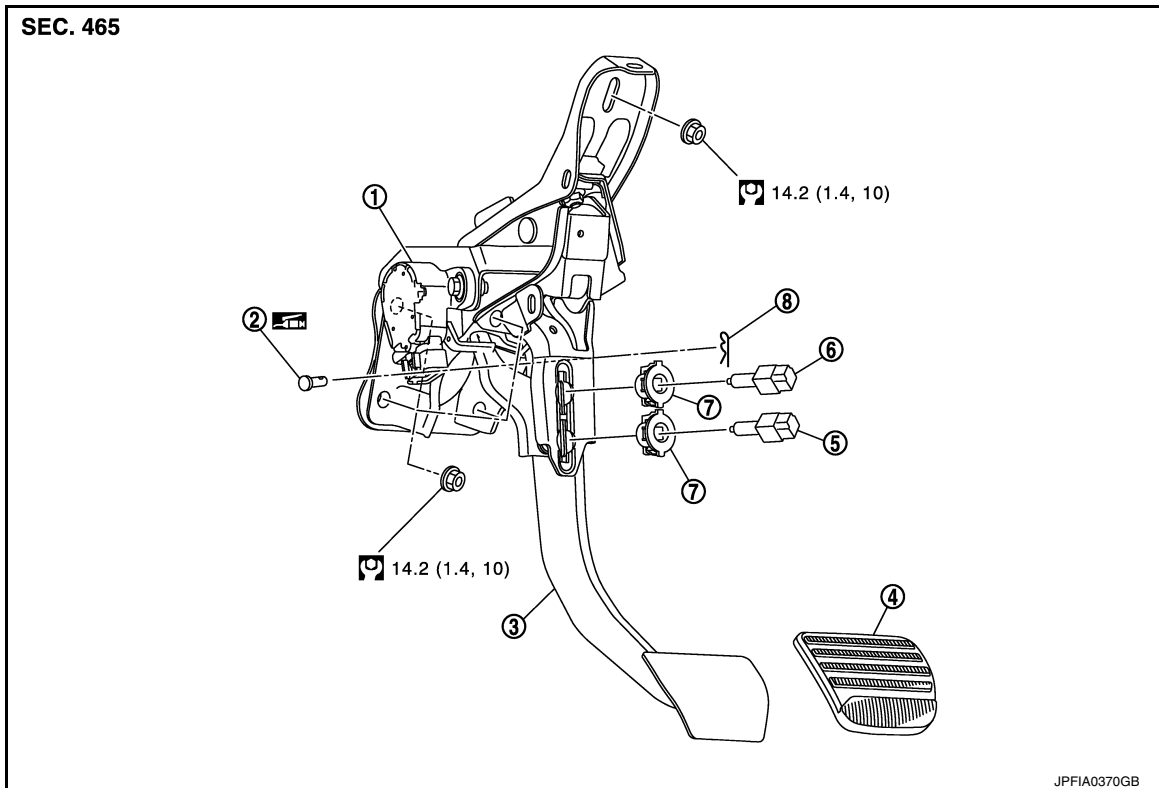

- | | | |
|---|----------------------|-------------------------|
| 1. Brake pedal stroke sensor (with pre-crash seat belt) | 2. Clevis pin | 3. Brake pedal assembly |
| 4. Brake pedal pad | 5. ASCD brake switch | 6. Stop lamp switch |
| 7. Clip | 8. Snap pin | |

: Apply multi-purpose grease.

Refer to [GI-4, "Components"](#) for symbols not described on the above.

Removal and Installation

INFOID:0000000010585128

REMOVAL

1. Remove instrument lower panel LH. Refer to [IP-12, "Exploded View"](#).
2. Remove steering column assembly. Refer to [ST-18, "WITHOUT ELECTRIC MOTOR : Exploded View"](#) (without electric motor), [ST-21, "WITH ELECTRIC MOTOR : Exploded View"](#) (with electric motor).
3. Disconnect the stop lamp switch and ASCD brake switch harness connectors.
4. Disconnect the brake pedal stroke sensor harness connector (with pre-crash seat belt).
CAUTION:
Never removing brake pedal stroke sensor (with pre-crash seat belt).
5. Turn the stop lamp switch and ASCD brake switch counterclockwise to remove the stop lamp switch and ASCD brake switch.
6. Remove snap pin and clevis pin from clevis of brake booster.
7. Remove cowl top cover. Refer to [EXT-22, "Exploded View"](#).
8. Remove instrument panel assembly. Refer to [IP-12, "Exploded View"](#).
9. Slide the steering member rearward. Refer to [HA-53, "Exploded View"](#) (VQ37VHR), [HA-110, "Exploded View"](#) (VK50VE).

BRAKE PEDAL

< REMOVAL AND INSTALLATION >

10. Remove brake pedal assembly.

INSTALLATION

Note the following, and install in the reverse order of removal.

- Apply the multi-purpose grease to the clevis pin and the mating faces. (Not necessary if grease has been already applied)

NOTE:

The clevis pin may be inserted in either direction.

Inspection and Adjustment

INFOID:0000000010585129

INSPECTION AFTER REMOVAL

- Check the following items and replace the brake pedal assembly if necessary.
- Check the brake pedal upper rivet (made by aluminum) (A) for deformation.
- Check the brake pedal for bend, damage, and cracks on the welded parts.
- Check the lapping length (X) of sub-bracket (B) and slide plate (C).

Standard

X : 5.0 mm (0.197 in) or more

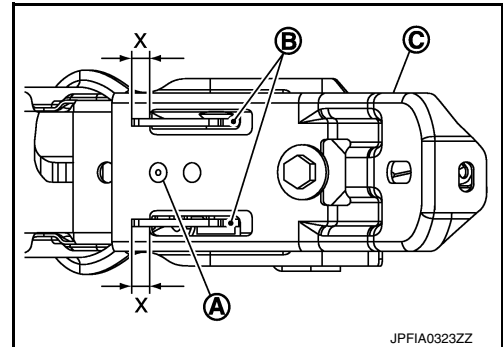

- Check clevis pin and plastic stopper (A) for damage and deformation. If any damage is found, replace clevis pin.

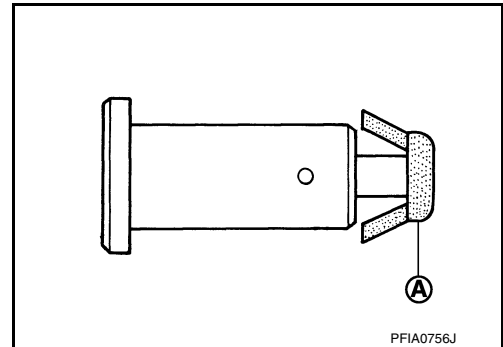

ADJUSTMENT AFTER INSTALLATION

Perform the brake pedal adjustment after installing the brake pedal assembly. Refer to [BR-9. "Inspection and Adjustment"](#).

BRAKE PIPING

< REMOVAL AND INSTALLATION >

BRAKE PIPING

FRONT

FRONT : Exploded View

INFOID:000000010585130

2 PISTON TYPE

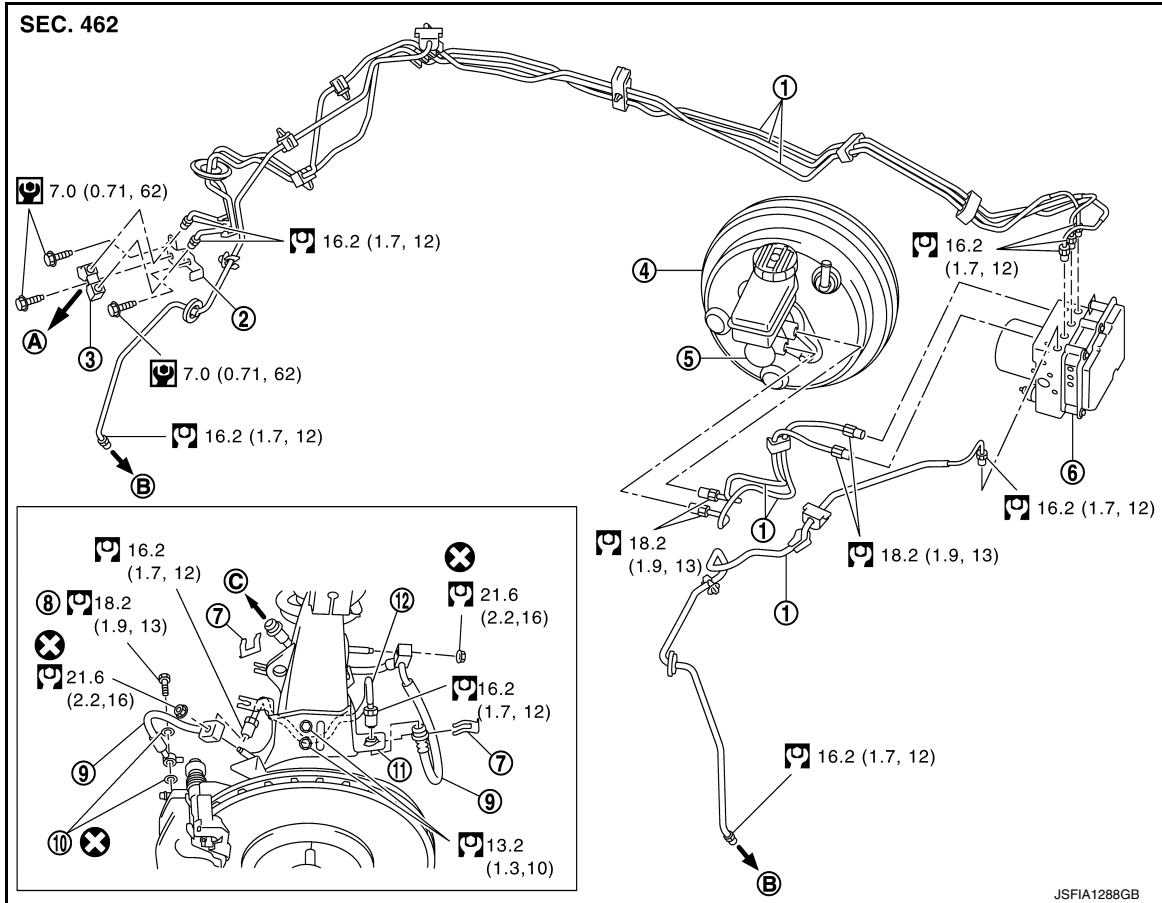

- | | | |
|-----------------------|------------------------|--|
| 1. Brake tube | 2. Connector bracket | 3. Connector |
| 4. Brake booster | 5. Master cylinder | 6. ABS actuator and electric unit (control unit) |
| 7. Lock plate | 8. Union bolt | 9. Brake hose |
| 10. Copper washer | 11. Brake hose bracket | 12. Brake tube |
| A. To rear brake tube | B. To front brake hose | C. To front brake tube |

Refer to [GI-4, "Components"](#) for symbols in the figure.

4 PISTON TYPE

BRAKE PIPING

< REMOVAL AND INSTALLATION >

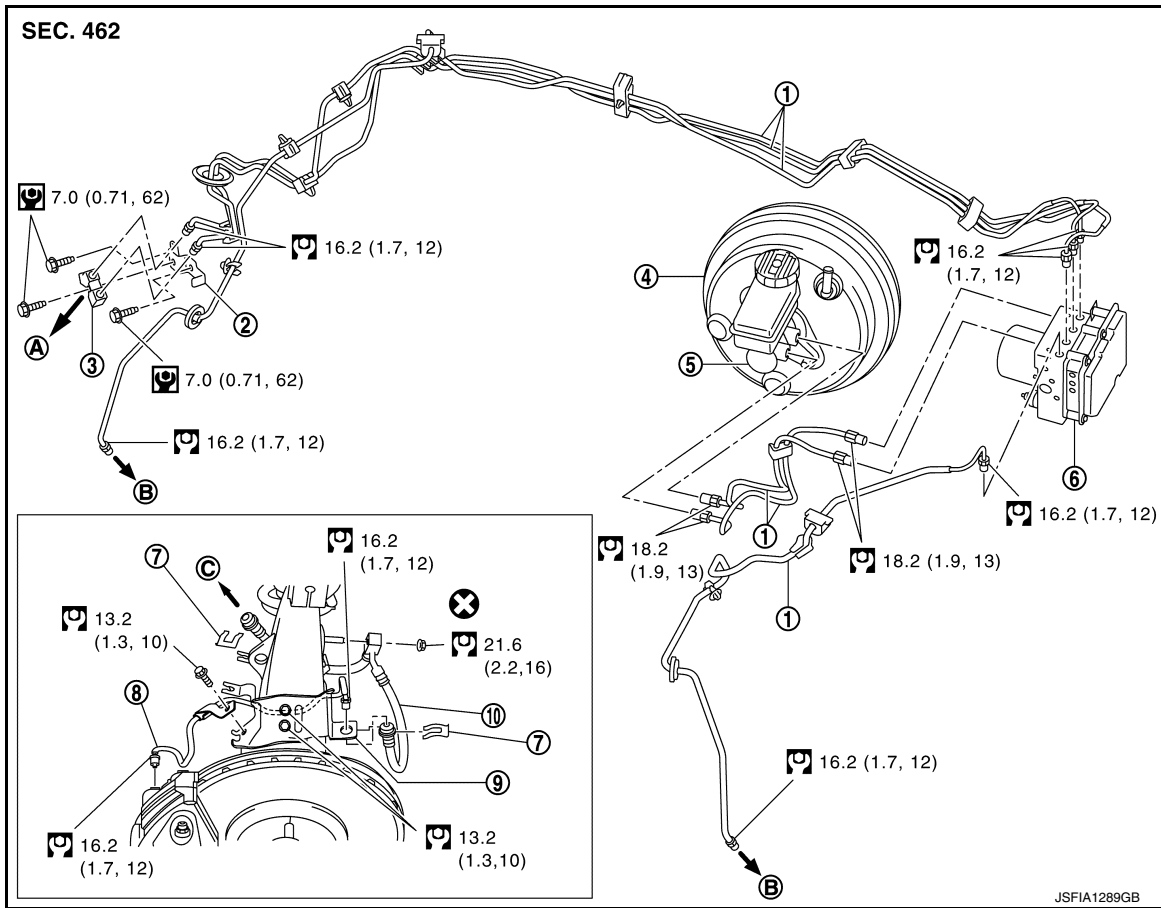

- | | | |
|-----------------------|------------------------|--|
| 1. Brake tube | 2. Connector bracket | 3. Connector |
| 4. Brake booster | 5. Master cylinder | 6. ABS actuator and electric unit (control unit) |
| 7. Lock plate | 8. Brake tube | 9. Brake hose bracket |
| 10. Brake hose | | |
| A. To rear brake tube | B. To front brake hose | C. To front brake tube |

Refer to [GI-4, "Components"](#) for symbols in the figure.

FRONT : Hydraulic Piping

INFOID:0000000010585131

2 PISTON TYPE

A
B
C
D
E
BR
G
H
I
J
K
L
M
N
O
P

BRAKE PIPING

< REMOVAL AND INSTALLATION >

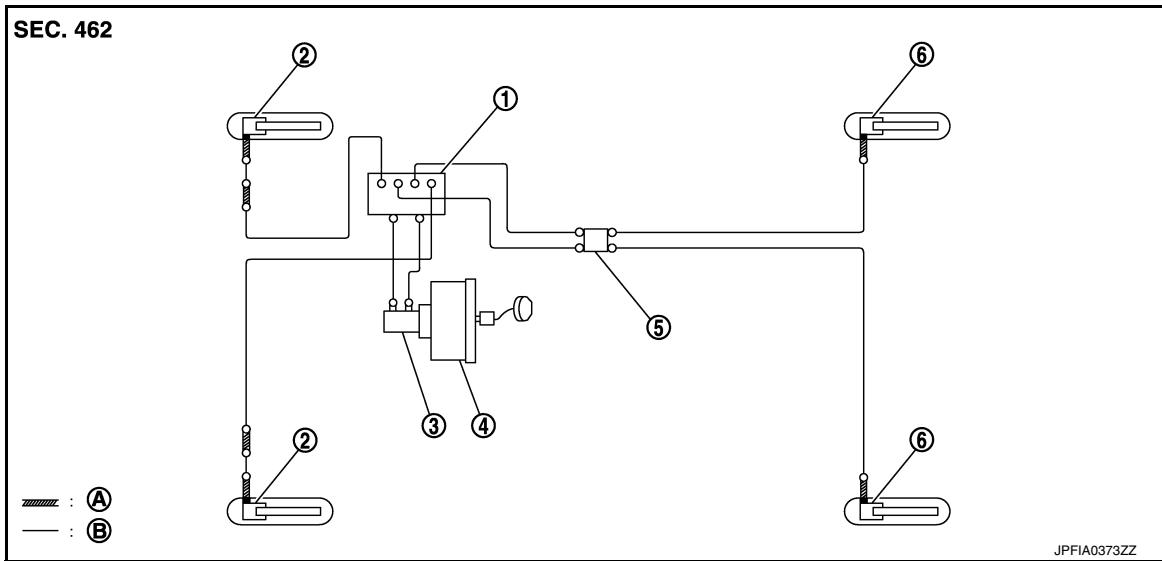

- | | | |
|--|---------------------|--------------------|
| 1. ABS actuator and electric unit (control unit) | 2. Front disc brake | 3. Master cylinder |
| 4. Brake booster | 5. Connector | 6. Rear disc brake |
| A. Brake hose | B. Brake tube | |

○: Flare nut

■: Union bolt

4 PISTON TYPE

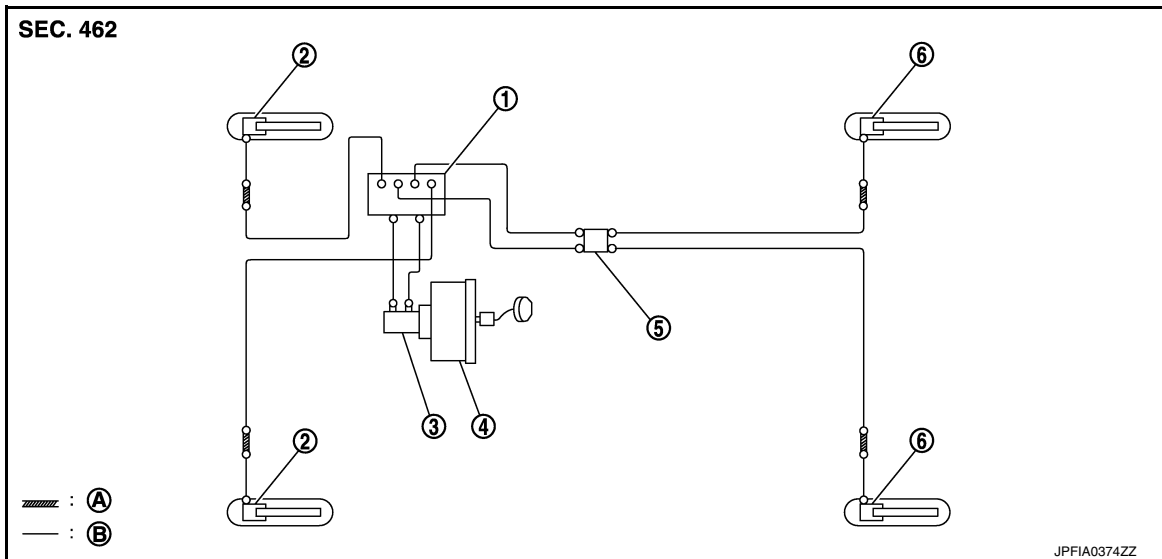

- | | | |
|--|---------------------|--------------------|
| 1. ABS actuator and electric unit (control unit) | 2. Front disc brake | 3. Master cylinder |
| 4. Brake booster | 5. Connector | 6. Rear disc brake |
| A. Brake hose | B. Brake tube | |

○: Flare nut

FRONT : Removal and Installation

INFOID:000000010585132

REMOVAL

2 Piston Type

BRAKE PIPING

< REMOVAL AND INSTALLATION >

CAUTION:

Never spill or splash brake fluid on painted surfaces. Brake fluid may seriously damage paint. Wipe it off immediately and wash with water if it gets on a painted surface.

1. Remove tires with power tool.
2. Drain brake fluid. Refer to [BR-12, "Draining"](#).
3. Loosen the flare nut with a flare nut wrench and separate the brake tube from the hose.

CAUTION:

- Never scratch the flare nut and the brake tube.
- Never bend sharply, twist or strongly pull out the brake hoses and tubes.
- Cover open end of brake tubes and hoses when disconnecting to prevent entrance of dirt.

4. Remove the union bolt and copper washers, and remove the brake hose from the brake caliper assembly.
5. Remove the brake hose mounting nut.
6. Remove the lock plate and remove the brake hose.

4 Piston Type

CAUTION:

Never spill or splash brake fluid on painted surfaces. Brake fluid may seriously damage paint. Wipe it off immediately and wash with water if it gets on a painted surface.

1. Remove tires with power tool.
2. Drain brake fluid. Refer to [BR-12, "Draining"](#).
3. Loosen the flare nut with a flare nut wrench and separate the brake tube from the hose and caliper.

CAUTION:

- Cover flare nut wrench with a cloth as not to damage the caliper.
- Never scratch the flare nut and the brake tube.
- Never bend sharply, twist or strongly pull out the brake hoses and tubes.
- Cover open end of brake tubes and hoses when disconnecting to prevent entrance of dirt.

4. Remove the brake tube mounting bolt and remove the brake tube.
5. Remove the brake hose mounting nut.
6. Remove the lock plate and remove the brake hose.

INSTALLATION

2 Piston Type

CAUTION:

Never spill or splash brake fluid on painted surfaces. Brake fluid may seriously damage paint. Wipe it off immediately and wash with water if it gets on a painted surface.

1. Assemble the union bolt and the copper washer to the brake hose.

CAUTION:

Never reuse the copper washer.

2. Align the brake hose pin to the projection (A) of the brake caliper assembly and tighten the union bolt (1) to the specified torque.
3. Install the brake tube to the brake hose, temporarily tighten the flare nut by hand until it does not rotate further, and fix the brake hose to the bracket with the lock plate.

CAUTION:

- Check that all brake hoses and tubes are not twisted and bent.
- Insert lock plate, according to the following instructions:
 - Steering knuckle side: Face the opening toward the front of vehicle.
 - Body side: Face the opening toward the inside of vehicle.
- Securely insert the lock plate all the way to the end.
- When installing the lock plate, never damage the brake hose, brake tube and wheel sensor harness.

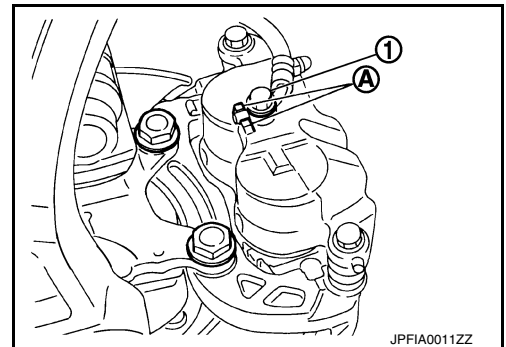

4. Tighten the brake hose mounting nuts to the specified torque.

CAUTION:

Never reuse the brake hose mounting nuts.

5. Tighten the flare nut to the specified torque with a flare nut crowfoot and a torque wrench.

BRAKE PIPING

< REMOVAL AND INSTALLATION >

CAUTION:

Never scratch the flare nut and the brake tube.

6. Refill with new brake fluid and perform the air bleeding. Refer to [BR-13, "Bleeding Brake System"](#).

CAUTION:

Never reuse drained brake fluid.

4 Piston Type

CAUTION:

Never spill or splash brake fluid on painted surfaces. Brake fluid may seriously damage paint. Wipe it off immediately and wash with water if it gets on a painted surface.

1. Install the brake tube to the brake hose and caliper, temporarily tighten the flare nut by hand until it does not rotate further, and fix the brake hose to the bracket with the lock plate.

CAUTION:

- Check that all brake hoses and tubes are not twisted and bent.
- Insert lock plate, according to the following instructions:
 - Steering knuckle side: Face the opening toward the front of vehicle.
 - Body side: Face the opening toward the inside of vehicle.
- Securely insert the lock plate all the way to the end.
- When installing the lock plate, never damage the brake hose, brake tube and wheel sensor harness.

2. Tighten the brake hose mounting nuts to the specified torque.

CAUTION:

Never reuse the brake hose mounting nuts.

3. Tighten the brake tube mounting bolt to the specified torque.
4. Tighten the flare nut to the specified torque with a flare nut crowfoot and a torque wrench.

CAUTION:

- Cover flare nut wrench with a cloth as not to damage the caliper.
- Never scratch the flare nut and the brake tube.

5. Refill with new brake fluid and perform the air bleeding. Refer to [BR-13, "Bleeding Brake System"](#).

CAUTION:

Never reuse drained brake fluid.

FRONT : Inspection

INFOID:000000010585133

INSPECTION AFTER INSTALLATION

1. Check the brake hoses and tubes for the following: no scratches; no twist and deformation; no interference with other components when steering the steering wheel; no looseness at connections.
2. Depress the brake pedal with a force of 785 N (80 kg, 177 lb) and hold down the pedal for approximately 5 seconds with the engine running. Check for any fluid leakage.

CAUTION:

Retighten the applicable connection to the specified torque and repair any abnormal (damaged, worn or deformed) part if any brake fluid leakage is present.

REAR

REAR : Exploded View

INFOID:000000010585134

1 PISTON TYPE

BRAKE PIPING

< REMOVAL AND INSTALLATION >

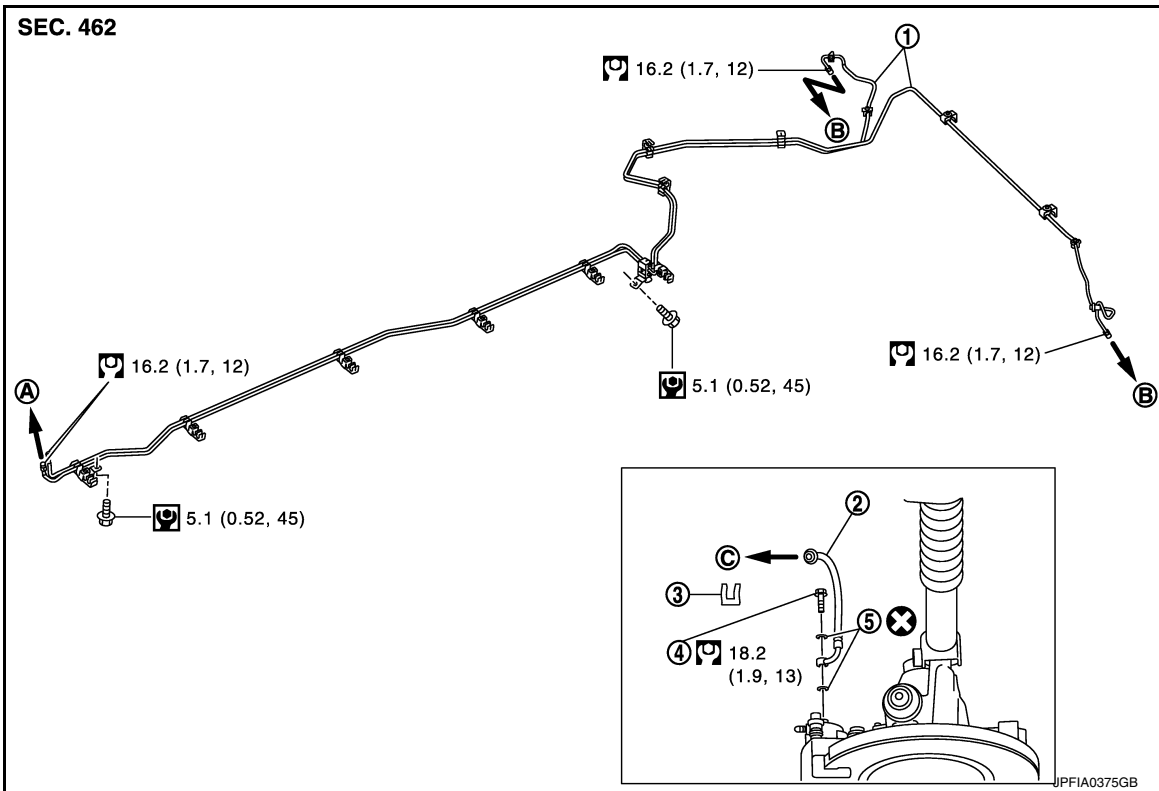

- | | | |
|-----------------|-----------------------|-----------------------|
| 1. Brake tube | 2. Brake hose | 3. Lock plate |
| 4. Union bolt | 5. Copper washer | |
| A. To connector | B. To rear brake hose | C. To rear brake tube |

Refer to [GI-4, "Components"](#) for symbols in the figure.

2 PISTON TYPE

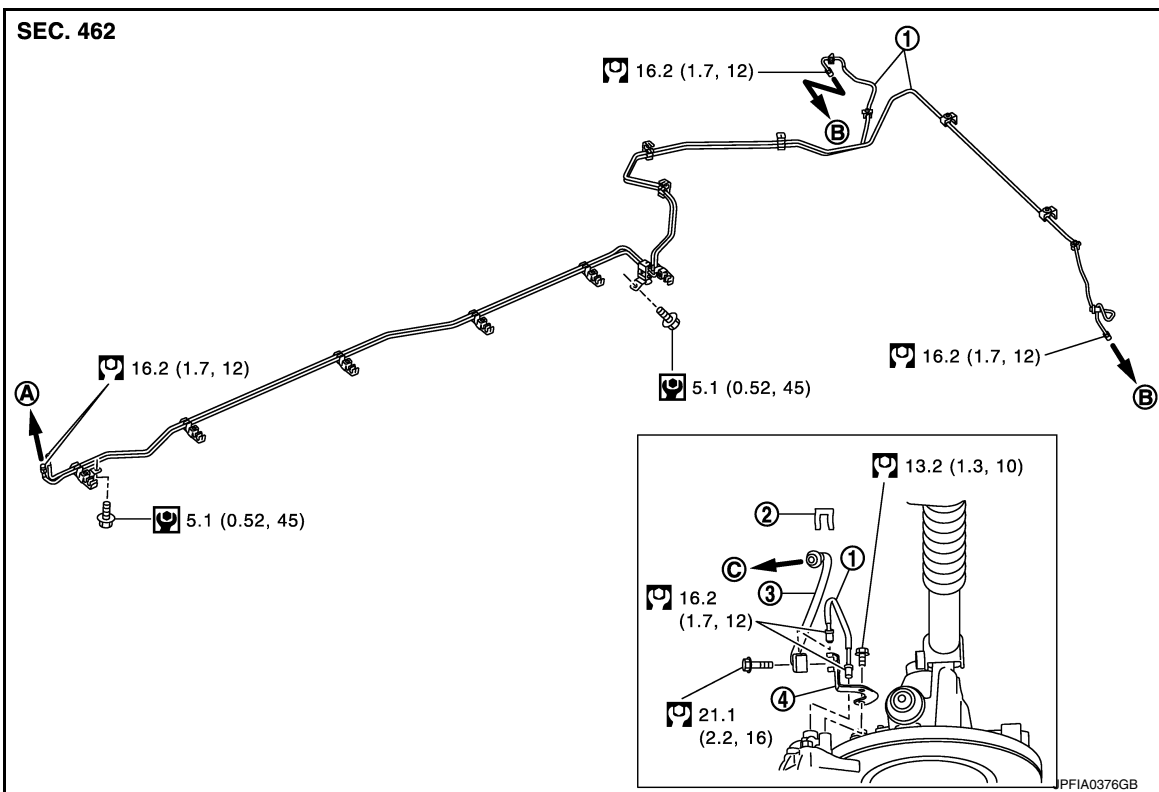

A
B
C
D
E
BR
G
H
I
J
K
L
M
N
O
P

BRAKE PIPING

< REMOVAL AND INSTALLATION >

- | | | |
|-----------------------|-----------------------|-----------------------|
| 1. Brake tube | 2. Lock plate | 3. Brake hose |
| 4. Brake hose bracket | | |
| A. To connector | B. To rear brake hose | C. To rear brake tube |
- Refer to [GI-4, "Components"](#) for symbols in the figure.

REAR : Hydraulic Piping

INFOID:0000000010585135

1 PISTON TYPE

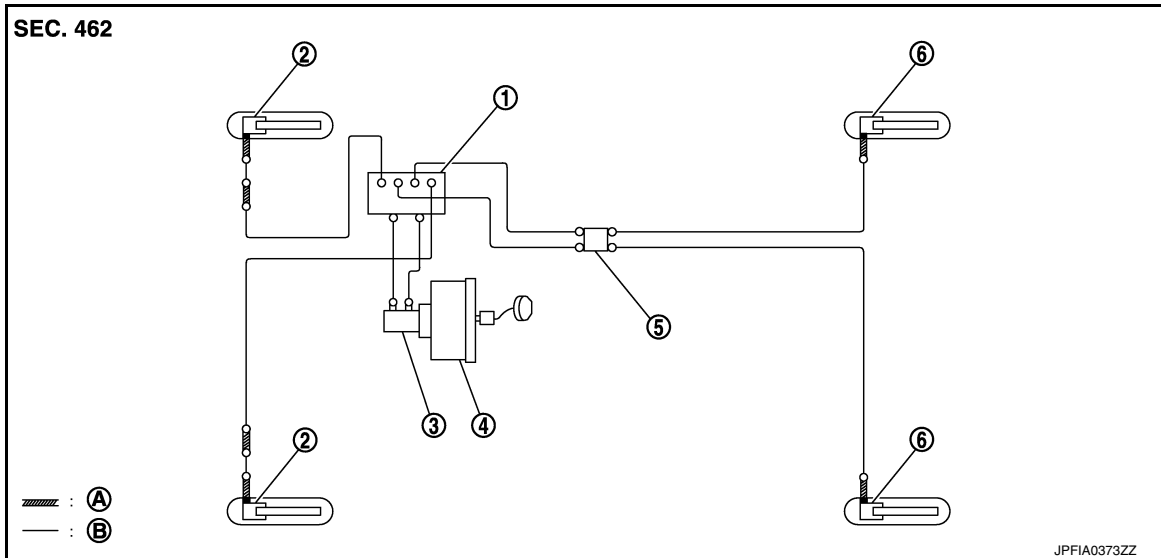

- | | | |
|--|---------------------|--------------------|
| 1. ABS actuator and electric unit (control unit) | 2. Front disc brake | 3. Master cylinder |
| 4. Brake booster | 5. Connector | 6. Rear disc brake |
- A. Brake hose
 B. Brake tube
- : Flare nut
 ■: Union bolt

2 PISTON TYPE

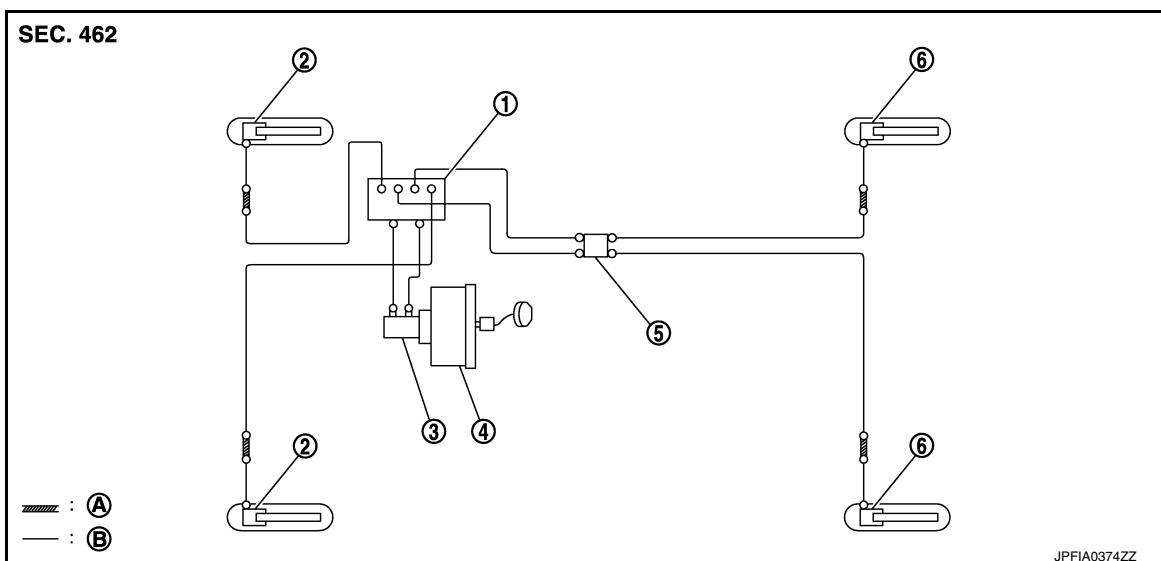

BRAKE PIPING

< REMOVAL AND INSTALLATION >

- | | | |
|--|---------------------|--------------------|
| 1. ABS actuator and electric unit (control unit) | 2. Front disc brake | 3. Master cylinder |
| 4. Brake booster | 5. Connector | 6. Rear disc brake |
| A. Brake hose | B. Brake tube | |

○: Flare nut

REAR : Removal and Installation

INFOID:000000010585136

REMOVAL

1 Piston Type

CAUTION:

Never spill or splash brake fluid on painted surfaces. Brake fluid may seriously damage paint. Wipe it off immediately and wash with water if it gets on a painted surface.

1. Remove tires with power tool.
2. Drain brake fluid. Refer to [BR-12, "Draining"](#).
3. Loosen the flare nut with a flare nut wrench and separate the brake tube from the hose.

CAUTION:

- **Never scratch the flare nut and the brake tube.**
- **Never sharply bend, twist or strongly pull the brake hoses and tubes.**
- **Cover the open end of brake tubes and hoses when disconnecting to prevent entrance of dirt.**

4. Remove the union bolt and remove the brake hose from the brake caliper assembly.
5. Remove the lock plate and remove the brake hose from the vehicle.

2 Piston Type

CAUTION:

Never spill or splash brake fluid on painted surfaces. Brake fluid may seriously damage paint. Wipe it off immediately and wash with water if it gets on a painted surface.

1. Remove tires with power tool.
2. Drain brake fluid. Refer to [BR-12, "Draining"](#).
3. Loosen the flare nut with a flare nut wrench and separate the brake tube from the hose and caliper.

CAUTION:

- **Cover flare nut wrench with a cloth as not to damage the caliper.**
- **Never scratch the flare nut and the brake tube.**
- **Never sharply bend, twist or strongly pull the brake hoses and tubes.**
- **Cover the open end of brake tubes and hoses when disconnecting to prevent entrance of dirt.**

4. Remove brake hose mounting bolt.
5. Remove the lock plate and remove the brake hose from the vehicle.

INSTALLATION

1 Piston Type

CAUTION:

Never spill or splash brake fluid on painted surfaces. Brake fluid may seriously damage paint. Wipe it off immediately and wash with water if it gets on a painted surface.

1. Assemble the union bolt and the copper washer to the brake hose.

CAUTION:

Never reuse copper washer.

BRAKE PIPING

< REMOVAL AND INSTALLATION >

2. Install the brake hose L-pin by aligning it with the brake caliper assembly positioning hole, and tighten the union bolt (1) to the specified torque.

3. Connect the hose to the brake tube, temporarily tighten the flare nut by hand until it does not rotate further, and fix the brake hose to the bracket with the lock plate.

CAUTION:

- Check that all brake hoses and tubes are not twisted and bent.
- Insert lock plate, according to the following instructions:
 - Body side: Face the opening toward the inside of vehicle.
- Securely insert the lock plate all the way to the end.
- When installing the lock plate, never damage the brake hose and brake tube.

4. Tighten the flare nut to the specified torque with a flare nut crowfoot and torque wrench.

CAUTION:

Never scratch the flare nut and the brake tube.

5. Refill with new brake fluid and perform the air bleeding. Refer to [BR-13, "Bleeding Brake System"](#).

CAUTION:

Never reuse drained brake fluid.

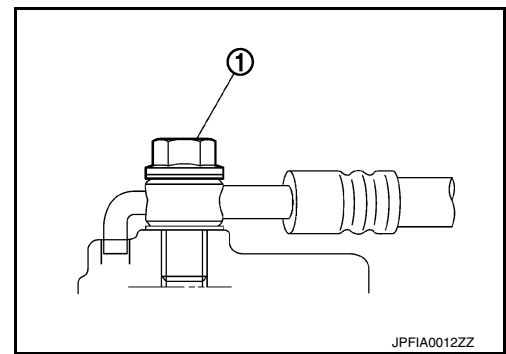

2 Piston Type

CAUTION:

Never spill or splash brake fluid on painted surfaces. Brake fluid may seriously damage paint. Wipe it off immediately and wash with water if it gets on a painted surface.

1. Connect the hose to the brake tube, temporarily tighten the flare nut by hand until it does not rotate further, and fix the brake hose to the bracket with the lock plate.

CAUTION:

- Check that all brake hoses and tubes are not twisted and bent.
- Insert lock plate, according to the following instructions:
 - Body side: Face the opening toward the inside of vehicle.
- Securely insert the lock plate all the way to the end.
- When installing the lock plate, never damage the brake hose and brake tube.

2. Tighten the brake hose mounting bolt to the specified torque.

3. Tighten the flare nut to the specified torque with a flare nut crowfoot and torque wrench.

CAUTION:

- Cover flare nut wrench with a cloth as not to damage the caliper.
- Never scratch the flare nut and the brake tube.

4. Refill with new brake fluid and perform the air bleeding. Refer to [BR-13, "Bleeding Brake System"](#).

CAUTION:

Never reuse drained brake fluid.

REAR : Inspection

INFOID:000000010585137

INSPECTION AFTER INSTALLATION

1. Check the brake hoses and tubes for the following: no scratches; no twist and deformation; no interference with other components when steering the steering wheel; no looseness at connections.

2. Depress the brake pedal with a force of 785 N (80 kg, 177 lb) and hold down the pedal for approximately 5 seconds with the engine running. Check for any fluid leakage.

CAUTION:

Retighten the applicable connection to the specified torque and repair any abnormal (damaged, worn or deformed) part if any brake fluid leakage is present.

BRAKE MASTER CYLINDER

< REMOVAL AND INSTALLATION >

BRAKE MASTER CYLINDER

Exploded View

INFOID:000000010585138

WITHOUT ICC

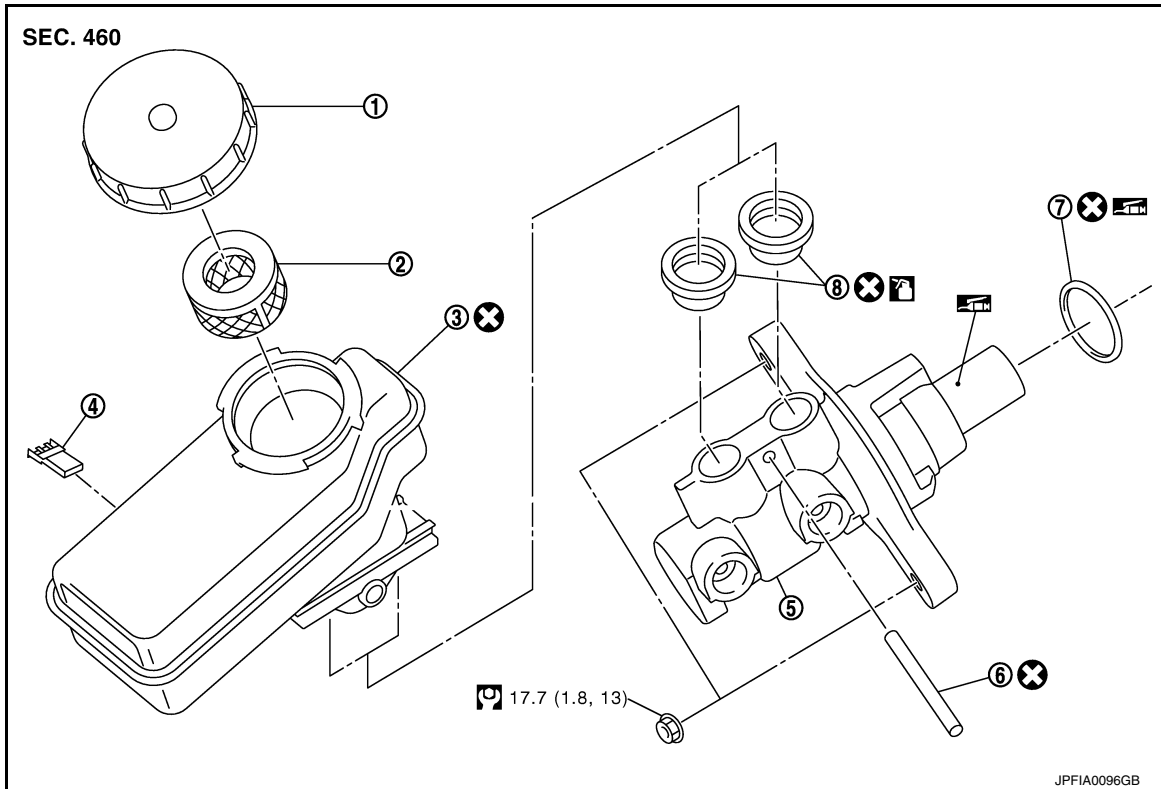

- | | | |
|---------------------------------------|------------------|-------------------|
| 1. Reservoir cap | 2. Oil strainer | 3. Reservoir tank |
| 4. Brake fluid level switch connector | 5. Cylinder body | 6. Pin |
| 7. O-ring | 8. Grommet | |

: Apply silicone grease.

: Apply brake fluid.

Refer to [GI-4. "Components"](#) for symbols not described on the above.

WITH ICC

A
B
C
D
E
BR
G
H
I
J
K
L
M
N
O
P

BRAKE MASTER CYLINDER

< REMOVAL AND INSTALLATION >

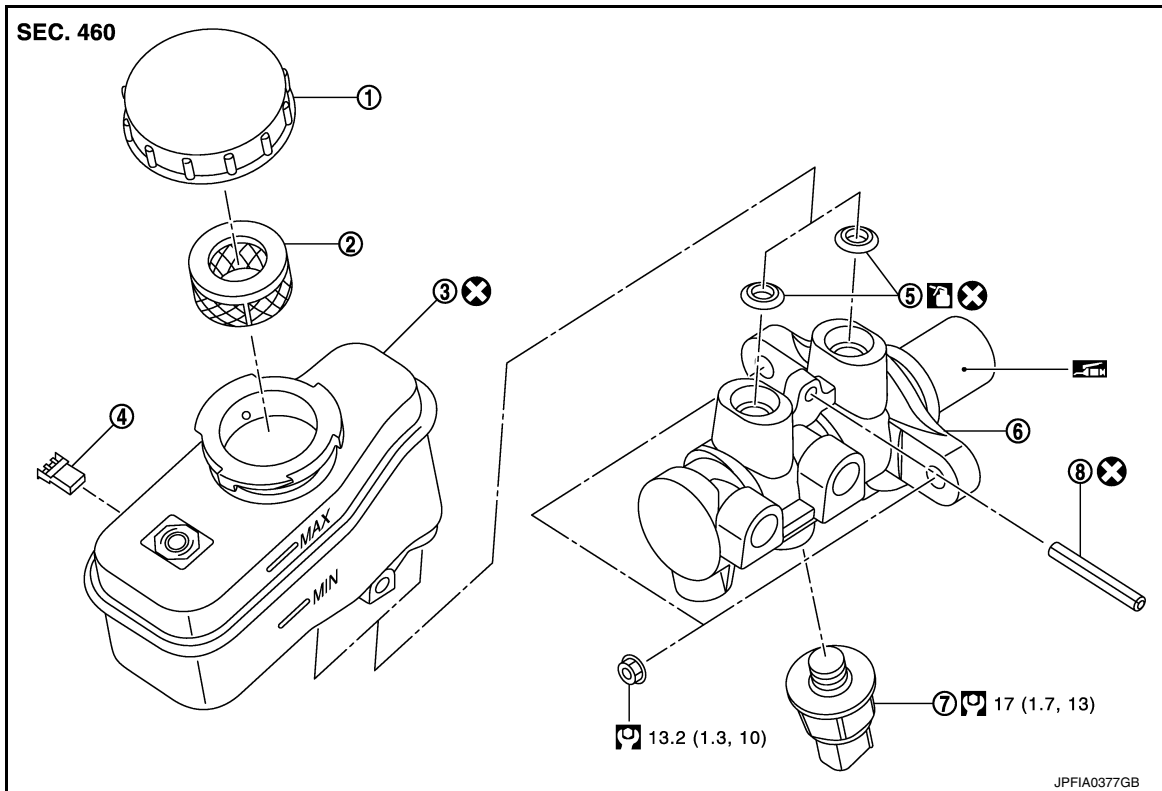

- | | | |
|---------------------------------------|-----------------|-------------------|
| 1. Reservoir cap | 2. Oil strainer | 3. Reservoir tank |
| 4. Brake fluid level switch connector | 5. Grommet | 6. Cylinder body |
| 7. Pressure sensor | 8. Pin | |

 Apply silicone grease.

 Apply brake fluid.

Refer to [GI-4. "Components"](#) for symbols not described on the above.

Removal and Installation

INFOID:000000010585139

REMOVAL

CAUTION:

Never spill or splash brake fluid on painted surfaces. Brake fluid may seriously damage paint. Wipe it off immediately and wash with water if it gets on a painted surface.

1. Remove the master cylinder cover.
2. Remove hoodledge cover. Refer to [EXT-22. "Exploded View"](#).
3. Drain brake fluid. Refer to [BR-12. "Draining"](#).
4. Separate the brake tube from the master cylinder assembly with a flare nut wrench.

CAUTION:

Never scratch the flare nut and the brake tube.

5. Remove master cylinder mounting nuts.
6. Separate the brake fluid level switch harness connector.
7. Separate the pressure sensor harness connector (with ICC).
8. Remove the master cylinder assembly.

CAUTION:

- **Depress the brake pedal several times to release the vacuum pressure from the brake booster. Then remove the master cylinder assembly.**
- **Never depress the brake pedal after the master cylinder assembly is removed.**
- **The piston of the master cylinder assembly is exposed. Never damage it when removing the master cylinder.**

BRAKE MASTER CYLINDER

< REMOVAL AND INSTALLATION >

- The piston may drop off when pulled out strongly. Never hold the piston. Hold the cylinder body when handling the master cylinder assembly.

INSTALLATION

CAUTION:

Never spill or splash brake fluid on painted surfaces. Brake fluid may seriously damage paint. Wipe it off immediately and wash with water if it gets on a painted surface.

Note the following, and install in the reverse order of removal.

- Never depress the brake pedal after the master cylinder assembly is removed.
- Apply silicone grease to the brake booster [see (A) in the figure] when installing the master cylinder assembly to the brake booster.
- The piston of the master cylinder assembly is exposed. Never damage it when handling the master cylinder and check that no dirt and dust are present on the piston before installation. Clean it with new brake fluid if necessary.
- The piston may drop off when pulled strongly. Never hold the piston. Hold the cylinder body when handling the master cylinder assembly.
- Never reuse the O ring.
- Temporarily tighten the brake tube flare nut to the master cylinder assembly by hand. Then tighten it to the specified torque with a flare nut crowfoot and torque wrench. Refer to [BR-22, "FRONT : Exploded View"](#).

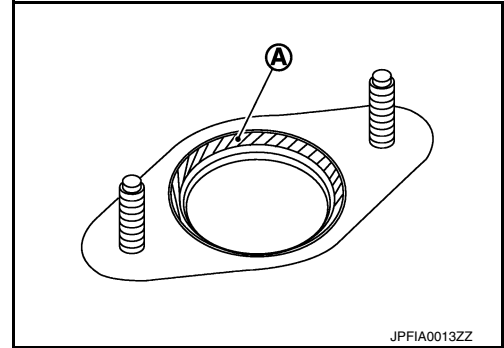

A
B
C
D
E
BR

CAUTION:

Never scratch the flare nut and the brake tube.

- After installation, perform the air bleeding. Refer to [BR-13, "Bleeding Brake System"](#)

CAUTION:

Never reuse drained brake fluid.

Disassembly and Assembly

INFOID:000000010585140

DISASSEMBLY

CAUTION:

- Never disassemble the cylinder body.
- Remove the reservoir tank only when necessary.

1. Fix the master cylinder assembly to a vise.

CAUTION:

Always set copper plates or cloth between vise grips when fixing the cylinder body to a vise. Never overtighten the vise.

2. Remove the reservoir tank mounting pin with a pin punch.
3. Remove the reservoir tank and grommet from the cylinder body.

CAUTION:

Never drop the removed parts. The parts must not be reused if they are dropped.

4. Remove the pressure sensor (with ICC).

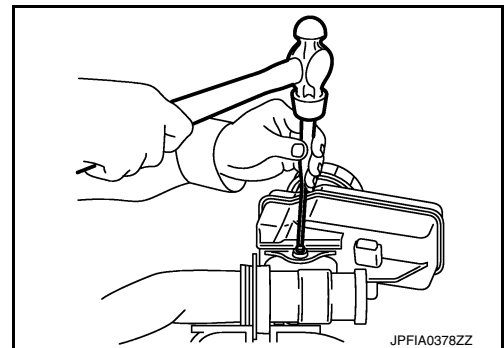

I
J
K
L
M
N
O

ASSEMBLY

1. Install the pressure sensor (with ICC).
2. Apply new brake fluid to the grommet and install it to the cylinder body.

CAUTION:

- Never use mineral oil such as gasoline or light oil.
- Never reuse the grommets.

3. Install the reservoir tank to the cylinder body.

CAUTION:

- Never drop the parts when installing. The parts must not be reused if they are dropped.
- Never reuse the reservoir tank.

P

BRAKE MASTER CYLINDER

< REMOVAL AND INSTALLATION >

4. Fix the cylinder body to a vise.

CAUTION:

- Place the reservoir tank with the chamfered pin hole (←) facing up.
- Always set copper plates or cloth between vise grips when fixing the cylinder body to a vise. Never overtighten the vise.

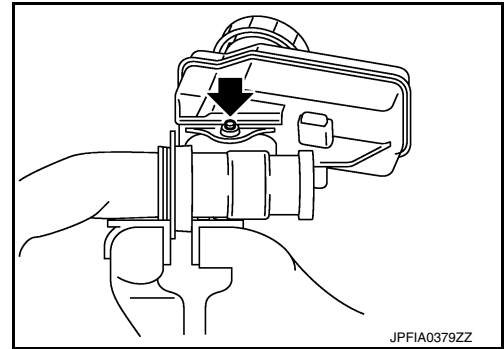

5. Tilt the reservoir tank so that a mounting pin can be inserted. Insert a mounting pin. Return the reservoir tank to the horizontal position. Insert another mounting pin into the pin hole on the opposite side in the same manner after the mounting pin passes through the cylinder body pin hole.

CAUTION:

Never reuse the mounting pins.

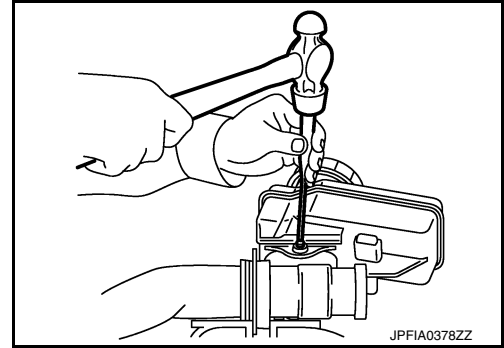

Inspection

INFOID:000000010585141

INSPECTION AFTER INSTALLATION

Fluid Leak

Check for brake fluid leakage from the cylinder body-to-brake booster mounting face, reservoir tank mounting face and brake tube connections.

BRAKE BOOSTER

< REMOVAL AND INSTALLATION >

BRAKE BOOSTER

Exploded View

INFOID:000000010585142

WITHOUT ICC

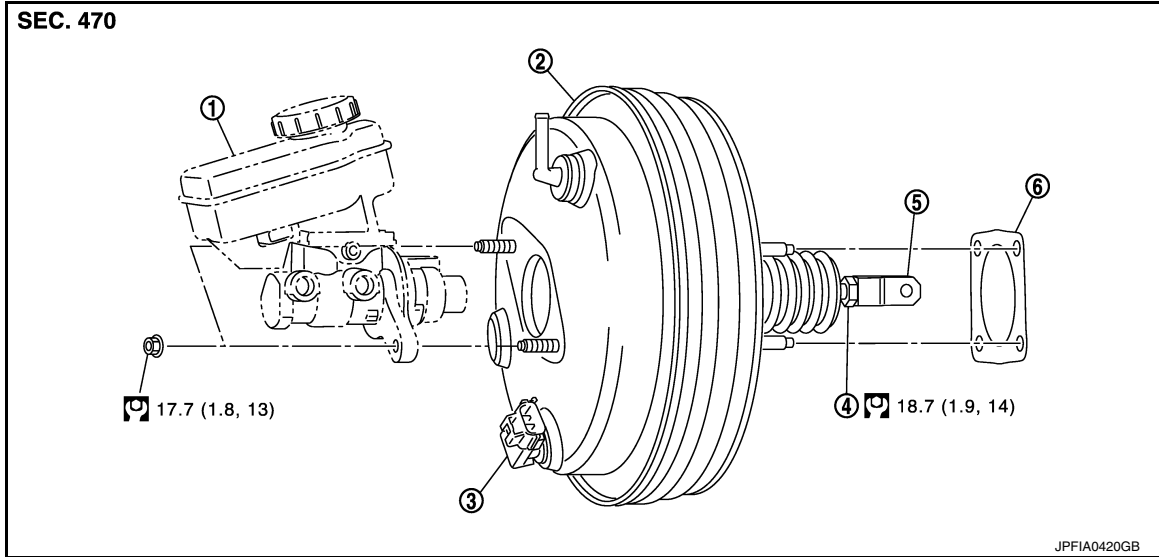

- | | | |
|-----------------------------|------------------|------------------|
| 1. Master cylinder assembly | 2. Brake booster | 3. Vacuum sensor |
| 4. Lock nut | 5. Clevis | 6. Gasket |

Refer to [GI-4, "Components"](#) for symbols in the figure.

WITH ICC

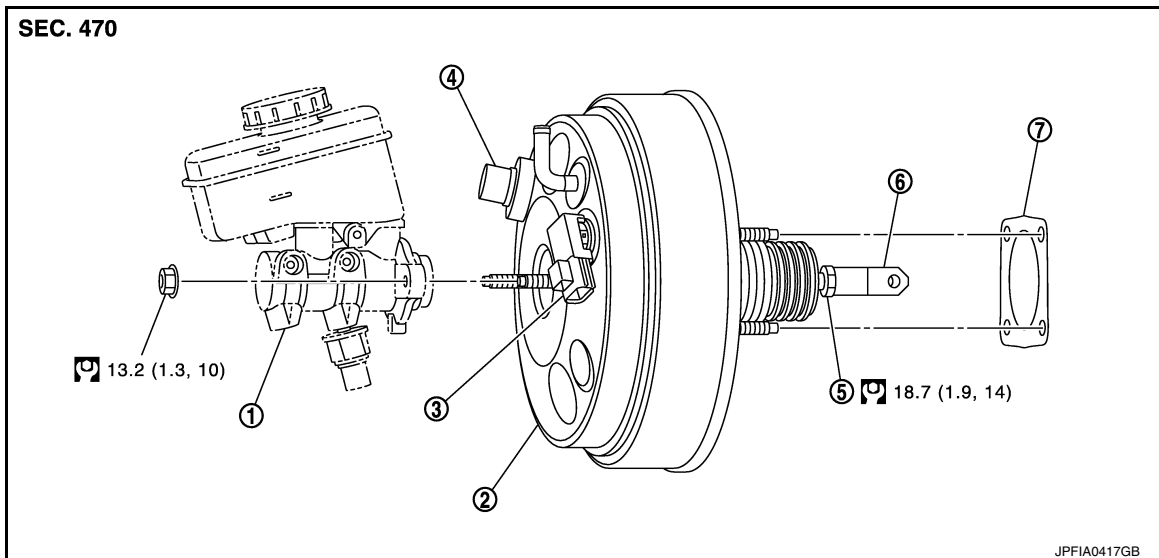

- | | | |
|-----------------------------|------------------|------------------|
| 1. Master cylinder assembly | 2. Brake booster | 3. Vacuum sensor |
| 4. Solenoid valve | 5. Lock nut | 6. Clevis |
| 7. Gasket | | |

Refer to [GI-4, "Components"](#) for symbols in the figure.

Removal and installation

INFOID:000000010585143

REMOVAL

CAUTION:

BRAKE BOOSTER

< REMOVAL AND INSTALLATION >

- **Never remove solenoid valve (with ICC) and vacuum sensor (VK50VE) from brake booster.**
 - **Replace solenoid valve (with ICC), vacuum sensor (VK50VE) and brake booster as a set.**
1. Remove master cylinder cover.
 2. Remove hoodledge cover. Refer to [EXT-22, "Exploded View"](#).
 3. Separate solenoid valve harness connector (with ICC) and vacuum sensor harness connector (with VK50VE).
 4. Remove brake master cylinder assembly. Refer to [BR-31, "Exploded View"](#).
CAUTION:
 - **Depress the brake pedal several times to release the vacuum pressure from the brake booster. Then remove the master cylinder assembly.**
 - **Never depress the brake pedal after the master cylinder assembly is removed.**
 - **The piston of the master cylinder assembly is exposed. Never damage it when removing the master cylinder.**
 - **The piston may drop off when pulled out strongly. Never hold the piston. Hold the cylinder body when handling the master cylinder assembly.**
 5. Remove vacuum hose from brake booster. Refer to [BR-39, "Exploded View"](#).
 6. Remove instrument lower panel LH. Refer to [IP-12, "Exploded View"](#).
 7. Remove snap pin (1) and clevis pin (2) from inside vehicle.
 8. Remove engine room cover (left side). (VK50VE) Refer to [EM-184, "Exploded View"](#).
 9. Remove low-pressure flexible hose bracket, place where low-pressure flexible hose and tube will not interfere with work. Refer to [HA-42, "LOW-PRESSURE FLEXIBLE HOSE : Removal and Installation"](#) (VQ37VHR), [HA-98, "LOW-PRESSURE FLEXIBLE HOSE : Removal and Installation"](#) (VK50VE).
 10. Remove brake tube [between master cylinder and ABS actuator and electric unit (control unit)]. Refer to [BR-22, "FRONT : Exploded View"](#).
 11. Separate brake tube [between ABS actuator and electric unit (control unit) and front brake hose] from ABS actuator and electric unit (control unit). Refer to [BR-22, "FRONT : Exploded View"](#).
 12. Remove nuts on brake booster and brake pedal assembly. Refer to [BR-20, "Exploded View"](#).
CAUTION:
Hold the brake booster so as to avoid dropping out.
 13. Remove brake booster from dash panel in engine room side.
CAUTION:
Never deform or bend the brake tubes.
NOTE:
If removing brake booster is difficult, remove clevis from brake booster.

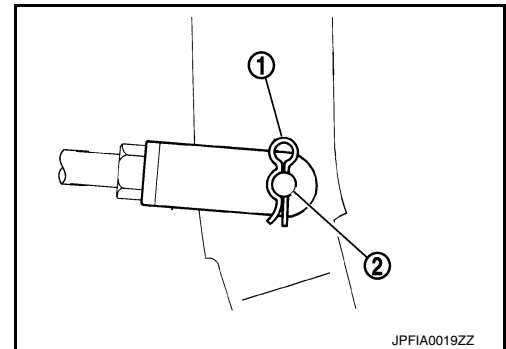

INSTALLATION

Note the following, and install in the reverse order of removal.

- Be careful not to damage brake booster stud bolt threads. If brake booster is tilted during installation, the dash panel may damage the threads.
- Never deform or bend the brake tubes when installing the brake booster.
- Always use a new gasket between the brake booster and the dash panel.
- Replace the clevis pin if it is damaged. Refer to [BR-21, "Inspection and Adjustment"](#).
- Install the brake pedal assembly and brake booster mounting nuts, and tighten it to the specified torque.
- After installation, perform the air bleeding. Refer to [BR-13, "Bleeding Brake System"](#).

CAUTION:

Never reuse drained brake fluid.

Inspection and Adjustment

INFOID:0000000010585144

INSPECTION BEFORE REMOVAL

Air Tight

CAUTION:

Check the air tight condition when the master cylinder and the brake booster is installed.

BRAKE BOOSTER

< REMOVAL AND INSTALLATION >

1. With a handy vacuum pump, apply vacuum pressure of -66.7 kPa (-500 mmHg, -19.70 inHg) to the brake booster.
2. If the air tight condition cannot be maintained, perform the following operation.
 - a. Check the no dirt and dust are present on the brake booster and brake master cylinder mating faces. Clean it if necessary.
 - b. Check O-ring on the master cylinder. If anything is found, replace the O-ring.
 - c. Check the air tight condition again. If the condition still cannot be maintained, replace the brake booster.

INSPECTION AFTER REMOVAL

Input Rod Length Inspection

1. Loosen the lock nut (1) and adjust the input rod (2) to the specified length (A).

Standard

A : Refer to [BR-68, "Brake Booster"](#).

2. Tighten the lock nut to the specified torque.

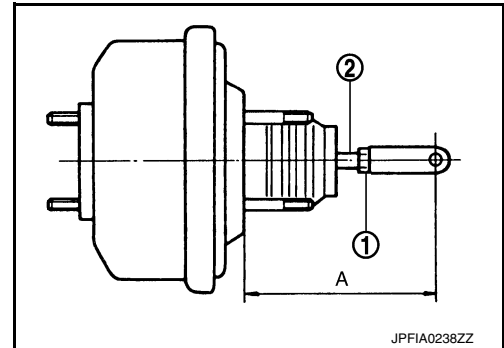

INSPECTION AFTER INSTALLATION

Operation

Depress the brake pedal several times at 5-second intervals with the engine stopped. Start the engine with the brake pedal fully depressed. Check that the clearance between brake pedal and dash lower pane decreases.

NOTE:

A slight impact with a small click may be felt on the pedal when the brake pedal is fully depressed. This is a normal phenomenon due to the brake system operation.

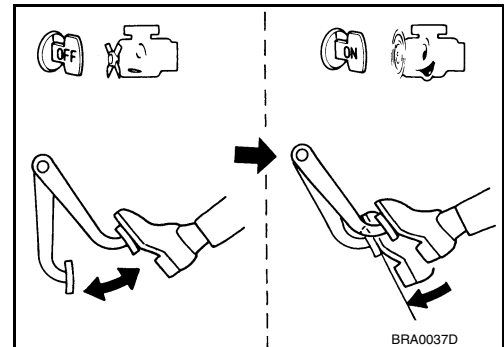

Air Tight

- Idle the engine for 1 minute to apply vacuum to the brake booster, and stop the engine. Then depress the brake pedal several times at 5-second intervals until the accumulated vacuum is released to atmospheric pressure. Check that the clearance between brake pedal and dash lower panel gradually increases (A → B → C) each time the brake pedal is depressed when performing this operation.

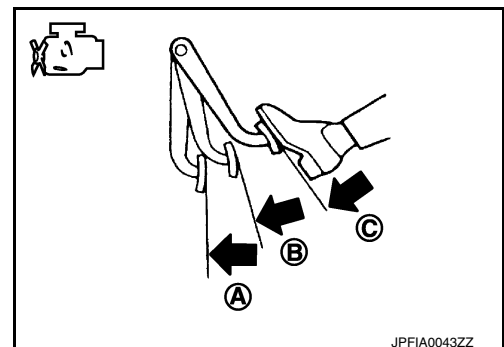

BRAKE BOOSTER

< REMOVAL AND INSTALLATION >

- Depress the brake pedal with the engine running. Then stop the engine while holding down the brake pedal. Check that the brake pedal stroke does not change after holding down the brake pedal for 30 seconds or more.

NOTE:

A slight impact with a small click may be felt on the pedal when the brake pedal is fully depressed. This is a normal phenomenon due to the brake system operation.

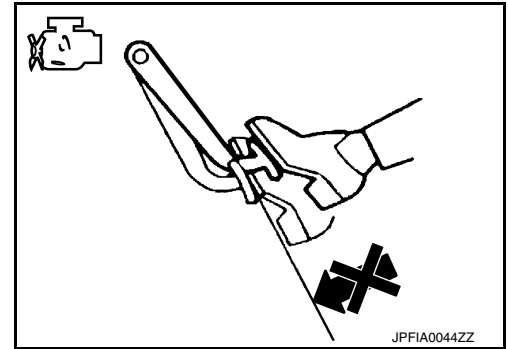

ADJUSTMENT AFTER INSTALLATION

Perform the brake pedal adjustment after installing the brake pedal assembly. Refer to [BR-9, "Inspection and Adjustment"](#).

VACUUM LINES

< REMOVAL AND INSTALLATION >

VACUUM LINES

Exploded View

INFOID:000000010585145

VQ37VHR

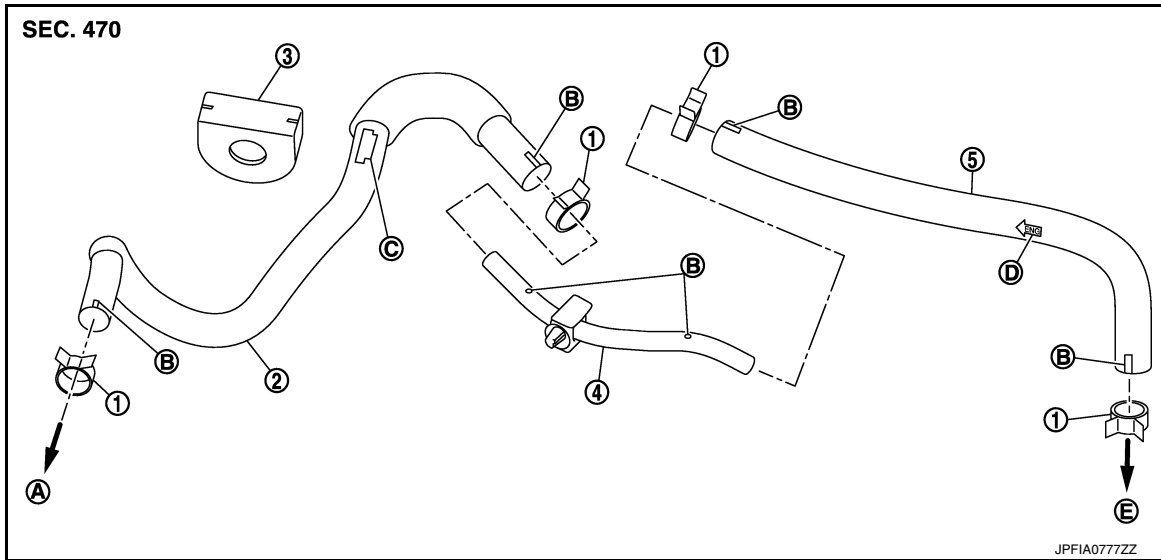

- | | | |
|-----------------------|---------------------------------------|---|
| 1. Clamp | 2. Vacuum hose | 3. Grommet |
| 4. Vacuum piping | 5. Vacuum hose (built in check valve) | C. Stamp indicating grommet installation position |
| A. To intake manifold | B. Paint mark | D. Stamp indicating engine direction |
| | E. To brake booster | |

VK50VE

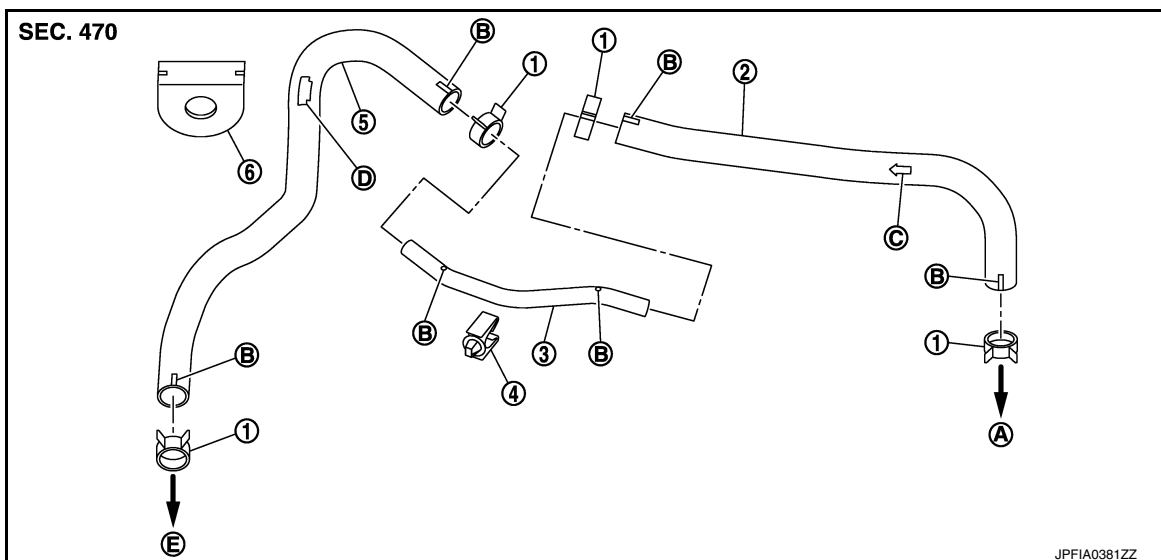

- | | | |
|---|---------------------------------------|--------------------------------------|
| 1. Clamp | 2. Vacuum hose (built in check valve) | 3. Vacuum piping |
| 4. Clip | 5. Vacuum hose | 6. Grommet |
| A. To brake booster | B. Paint mark | C. Stamp indicating engine direction |
| D. Stamp indicating grommet installation position | E. To intake manifold | |

VACUUM LINES

< REMOVAL AND INSTALLATION >

Removal and Installation

INFOID:0000000110585146

REMOVAL

1. Remove the engine cover. Refer to [EM-27. "Exploded View"](#) (VQ37VHR), [EM-184. "Exploded View"](#) (VK50VE).
2. Remove the cowl top cover. Refer to [EXT-22. "Exploded View"](#).
3. Remove the vacuum hose and tube.

INSTALLATION

Note the following, install in the reverse order of removal.

- Because vacuum hose contains a check valve, it must be installed in the correct position. Refer to the stamp to confirm correct installation. Brake booster will not operate normally if the hose is installed in the wrong direction.
- When installing vacuum hose, insert it until its tip reaches the back-end of length (A) or further as shown in the figure.

Standard

A : 24 mm (0.95 in) or more

- Face the marking side up when assembling (except for brake booster side).
- Face the marking side front when assembling (for brake booster side).

CAUTION:

Never use lubricating oil during assembly.

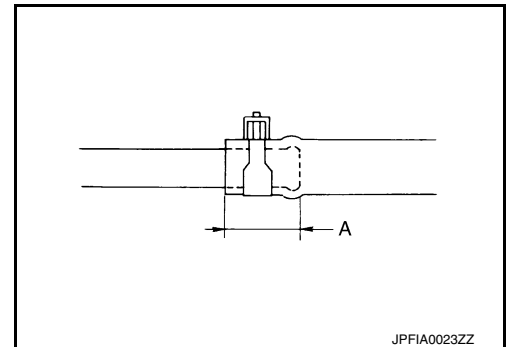

Inspection

INFOID:0000000110585147

INSPECTION AFTER REMOVAL

Appearance

Check for correct assembly, damage and deterioration.

Check Valve Airtightness

- Use a handy vacuum pump (A) to check.

When connected to the booster side (B):

Vacuum should decrease within 1.3 kPa (9.8 mm-Hg, 0.38 inHg) for 15 seconds under a vacuum of –66.7 kPa (–500 mmHg, –19.69 inHg).

When connected to the engine side (C):

Vacuum should not exist.

- Replace vacuum hose assembly if vacuum hose and check valve are malfunctioning.

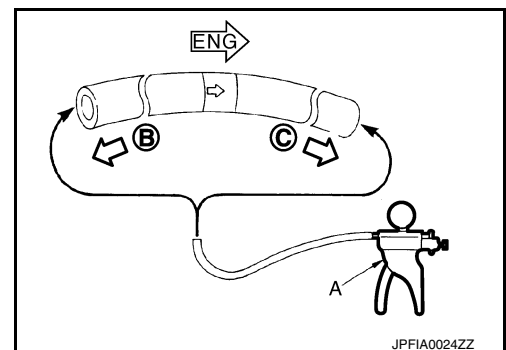

FRONT DISC BRAKE

< REMOVAL AND INSTALLATION >

FRONT DISC BRAKE BRAKE PAD (2 PISTON TYPE)

BRAKE PAD (2 PISTON TYPE) : Exploded View

INFOID:0000000010585148

FOR MEXICO

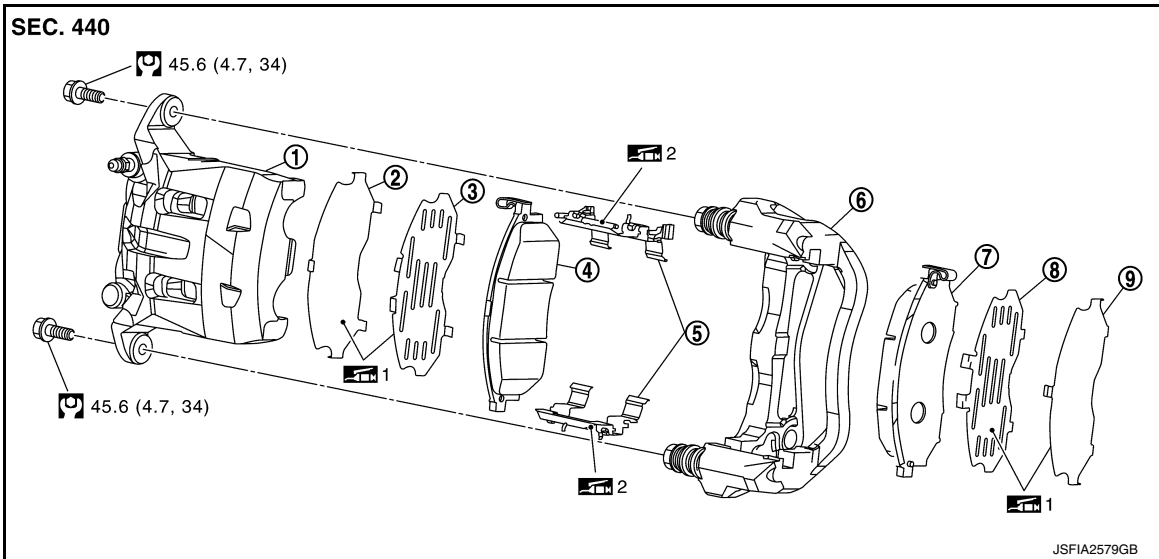

- | | | |
|-------------------------------------|---------------------|---------------------|
| 1. Cylinder body | 2. Inner shim cover | 3. Inner shim |
| 4. Inner pad (with pad wear sensor) | 5. Pad retainer | 6. Torque member |
| 7. Outer pad (with pad wear sensor) | 8. Outer shim | 9. Outer shim cover |

1: Apply MOLYKOTE® AS880N or silicone-based grease.

2: Apply MOLYKOTE® 7439 or equivalent.

Refer to [GI-4. "Components"](#) for symbols not described on the above.

Molykote is a registered trademark of Dow Corning Corporation.

EXPECT FOR MEXICO

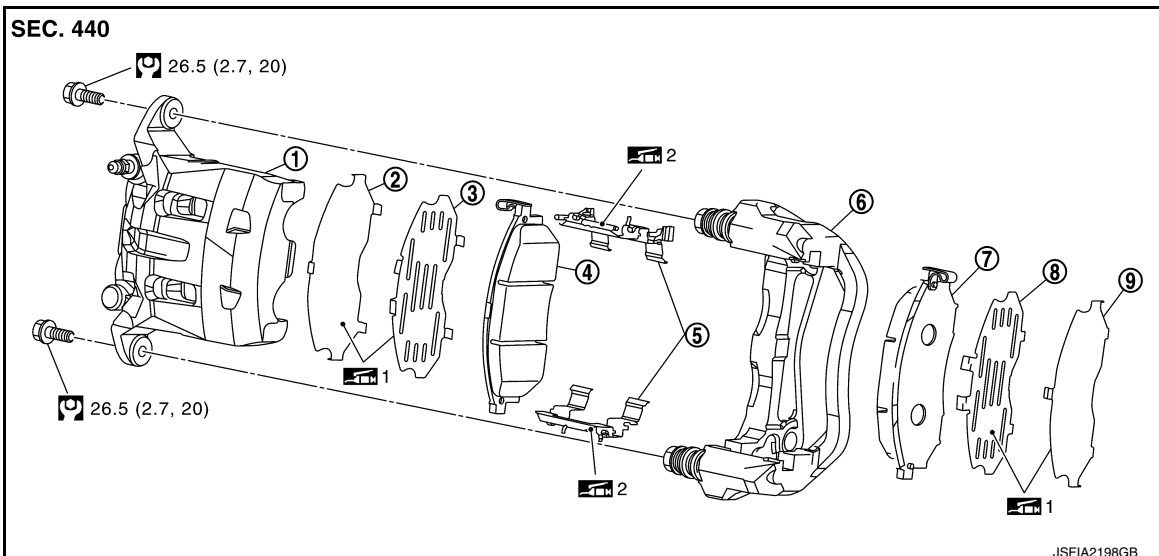

- | | | |
|-------------------------------------|---------------------|---------------------|
| 1. Cylinder body | 2. Inner shim cover | 3. Inner shim |
| 4. Inner pad (with pad wear sensor) | 5. Pad retainer | 6. Torque member |
| 7. Outer pad (with pad wear sensor) | 8. Outer shim | 9. Outer shim cover |

A
B
C
D
E
BR
G
H
I
J
K
L
M
N
O
P

FRONT DISC BRAKE

< REMOVAL AND INSTALLATION >

 1: Apply MOLYKOTE® AS880N or silicone-based grease.

 2: Apply MOLYKOTE® 7439 or equivalent.

Refer to [GI-4, "Components"](#) for symbols not described on the above.

Molykote is a registered trademark of Dow Corning Corporation.

BRAKE PAD (2 PISTON TYPE) : Removal and Installation

INFOID:0000000010585149

REMOVAL

WARNING:

Since dust covering the front brake has an affect on human body, the dust must be removed with a dust collector. Never splatter the dust with an air blow gun.

CAUTION:

- Never depress the brake pedal while removing the brake pads because the piston may pop out.
- Never spill or splash brake fluid on the disc rotor.

1. Remove tires with power tool.
2. Remove lower sliding pin bolt.
3. Suspend the cylinder body with suitable wire so that the brake hose will not stretch. Then remove the brake pads, shims, shim covers and pad retainers from the torque member.

CAUTION:

- Never deform the pad retainer when removing the pad retainer from the torque member.
- Never damage the piston boot.
- Never drop the brake pads, shims, and the shim covers.
- Remember each position of the removed brake pads.

INSTALLATION

WARNING:

Since dust covering the front brake has an affect on human body, the dust must be removed with a dust collector. Never splatter the dust with an air blow gun.

CAUTION:

- Never depress the brake pedal while removing the brake pads or the cylinder body because the piston may pop out.
- Never spill or splash brake fluid on the disc rotor.

1. Apply MOLYKOTE® 7439 or equivalent to the pad retainers before installing it to the torque member if the pad retainers has been removed.

CAUTION:

- Securely assemble the pad retainers so that it will not be lifted up from the torque member.
- Never deform the pad retainers.

Molykote is a registered trademark of Dow Corning Corporation.

2. Apply MOLYKOTE® AS880N or silicone-based grease to the mating faces between the shims and the shim covers and install them to the brake pad.

CAUTION:

Always replace the shims together with the shim covers when replacing the brake pad.

Molykote is a registered trademark of Dow Corning Corporation.

3. Install the brake pads to the torque member.

CAUTION:

Both inner and outer pads have a pad return system on the pad retainer. Install pad return lever (1) securely to pad wear sensor (2).

4. Install cylinder body to torque member.

CAUTION:

- Never damage the piston boot.
- When replacing brake pad with new one, check a brake fluid level in the reservoir tank because brake fluid returns to master cylinder reservoir tank when pressing piston in.

NOTE:

Use a disc brake piston tool to easily press piston.

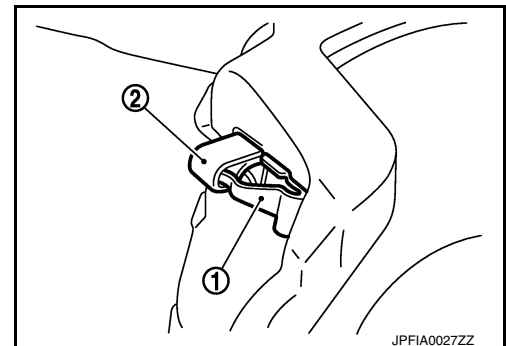

JPFIA0027ZZ

FRONT DISC BRAKE

< REMOVAL AND INSTALLATION >

5. Install the lower sliding pin bolt and tighten it to the specified torque.
6. Depress the brake pedal several times to check that no drag feel is present for the front disc brake. Refer to [BR-43, "BRAKE PAD \(2 PISTON TYPE\) : Inspection"](#).

BRAKE PAD (2 PISTON TYPE) : Inspection

INFOID:000000010585150

INSPECTION AFTER REMOVAL

Replace the shims and the shim covers if rust is excessively attached.

INSPECTION AFTER INSTALLATION

1. Check a drag of front disc brake. If any drag is found, follow the procedure described below.
2. Remove brake pads.
3. Press the pistons.

CAUTION:

- Never damage the piston boot.
- When replacing a pad with new one, check a brake fluid level in the reservoir tank because brake fluid returns to master cylinder reservoir tank when pressing piston in.

NOTE:

Use a disc brake piston tool to easily press piston.

4. Install brake pads.
5. Depress the brake pedal several times.
6. Check a drag of front disc brake again. If any drag is found, disassemble the cylinder body. Refer to [BR-47, "BRAKE CALIPER ASSEMBLY \(2 PISTON TYPE\) : Disassembly and Assembly"](#)
7. Burnish contact surfaces brake pads and disc rotor after refinishing or replacing brake pads, or if a soft pedal occurs at very low mileage. Refer to [BR-16, "BRAKE PAD : Inspection and Adjustment"](#).

BRAKE PAD (4 PISTON TYPE)

BRAKE PAD (4 PISTON TYPE) : Exploded View

INFOID:000000010585151

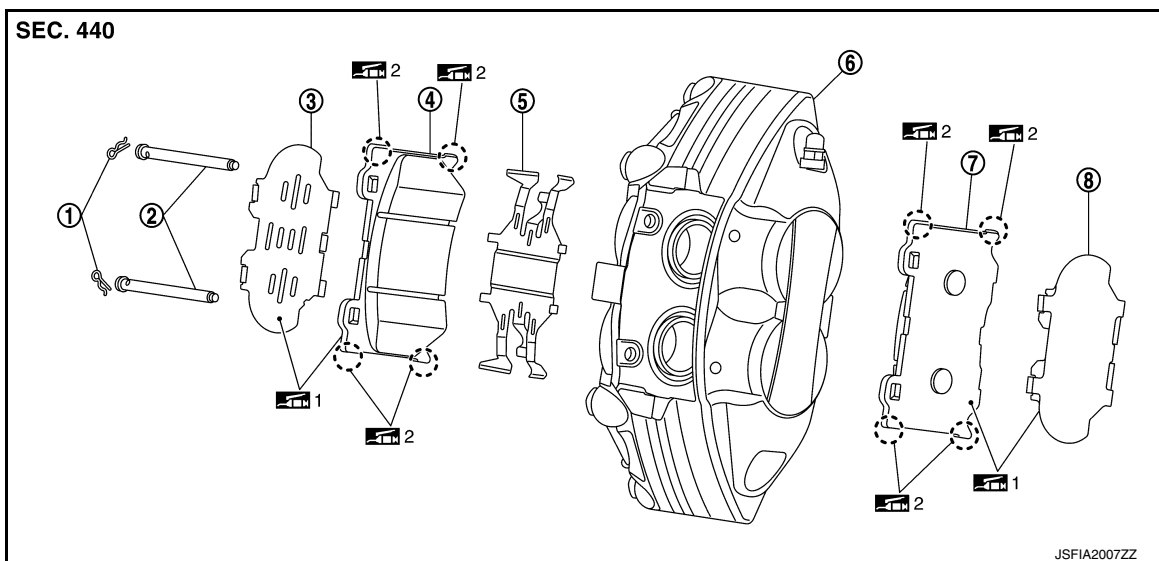

- | | | |
|-------------------------------------|-----------------|---------------|
| 1. Clip | 2. Pad pin | 3. Inner shim |
| 4. Inner pad (with pad wear sensor) | 5. Cross spring | 6. Caliper |
| 7. Outer pad | 8. Outer shim | |

1: Apply MOLYKOTE® AS880N or silicone-based grease.

2: Apply MOLYKOTE® 7439 or equivalent.

Refer to [GI-4, "Components"](#) for symbols not described on the above.

Molykote is a registered trademark of Dow Corning Corporation.

FRONT DISC BRAKE

< REMOVAL AND INSTALLATION >

BRAKE PAD (4 PISTON TYPE) : Removal and Installation

INFOID:000000010585152

REMOVAL

WARNING:

Since dust covering the front brake has an affect on human body, the dust must be removed with a dust collector. Never splatter the dust with an air blow gun.

CAUTION:

- Never depress the brake pedal while removing the brake pads because the piston may pop out.
- Never spill or splash brake fluid on the disc rotor and caliper.

1. Remove tires with power tool.
2. Remove clips (1) from pad pins.

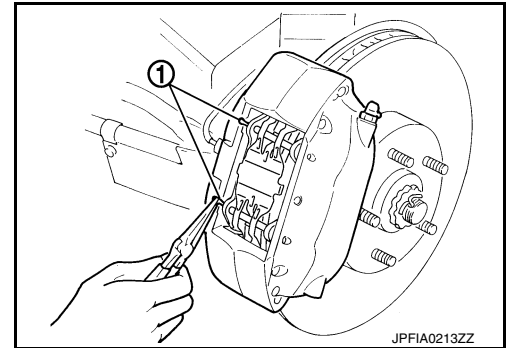

3. Remove pad pins while holding down cross spring, then remove cross spring from caliper.

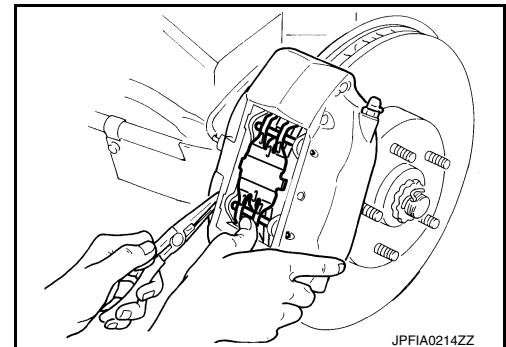

4. Using pliers, remove brake pads and shims from caliper.

CAUTION:

- Never damage the piston boot.
- Never drop the brake pads, shims.
- Remember each position of the removed brake pads.

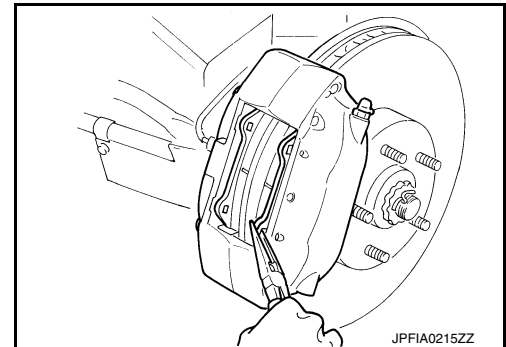

INSTALLATION

WARNING:

Since dust covering the front brake has an affect on human body, the dust must be removed with a dust collector. Never splatter the dust with an air blow gun.

CAUTION:

- Never depress the brake pedal while removing the brake pads because the piston may pop out.
- Never spill or splash brake fluid on the disc rotor and caliper.

1. Apply MOLYKOTE® AS880N or silicone-based grease to the mating faces between the brake pads and shims, and install shims to the brake pad.

CAUTION:

Always replace the shims together when replacing the brake pad.
Molykote is a registered trademark of Dow Corning Corporation.

FRONT DISC BRAKE

< REMOVAL AND INSTALLATION >

2. Apply MOLYKOTE® 7439 or equivalent to the mating faces between the brake pads and caliper. Molykote is a registered trademark of Dow Corning Corporation.
3. Install brake pads to caliper.
CAUTION:
 - Never damage the piston boot.
 - In the case of replacing a pad with new one, check a brake fluid level in the reservoir tank because brake fluid returns to master cylinder reservoir tank when pressing piston in.
- NOTE:**
Use a disc brake piston tool to easily press piston.
4. Install upper pad pin from the inner side, then install firmly to the outer side through the hole in the top of brake pad.
5. Place the top of cross spring (1) over the upper pad pin (2), press in the cross spring, install lower pad pin from the inner side to the outer side, and secure cross spring.
6. Install clips to the pad pins.
CAUTION:
If clip is not fully attached, pad pin or brake pad could fall out while vehicle is in motion.
7. Depress the brake pedal several times to check that no drag feel is present for the front disc brake. Refer to [BR-45. "BRAKE PAD \(4 PISTON TYPE\) : Inspection"](#).

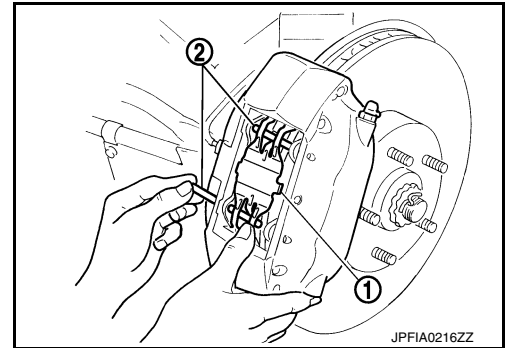

INFOID:000000010585153

BRAKE PAD (4 PISTON TYPE) : Inspection

INSPECTION AFTER REMOVAL

Replace the shims if rust is excessively attached.

INSPECTION AFTER INSTALLATION

1. Check a drag of front disc brake. If any drag is found, follow the procedure described below.
2. Remove brake pads.
3. Press the pistons.
CAUTION:
 - Never damage the piston boot.
 - When replacing a pad with new one, check a brake fluid level in the reservoir tank because brake fluid returns to master cylinder reservoir tank when pressing piston in.
- NOTE:**
Use a disc brake piston tool to easily press piston.
4. Install brake pads.
5. Depress the brake pedal several times.
6. Check a drag of front disc brake again. If any drag is found, disassemble the cylinder body. Refer to [BR-51. "BRAKE CALIPER ASSEMBLY \(4 PISTON TYPE\) : Disassembly and Assembly"](#)
7. Burnish contact surfaces brake pads and disc rotor after refinishing or replacing brake pads, or if a soft pedal occurs at very low mileage. Refer to [BR-16. "BRAKE PAD : Inspection and Adjustment"](#).

BRAKE CALIPER ASSEMBLY (2 PISTON TYPE)

BRAKE CALIPER ASSEMBLY (2 PISTON TYPE) : Exploded View

INFOID:000000010585154

REMOVAL

FRONT DISC BRAKE

< REMOVAL AND INSTALLATION >

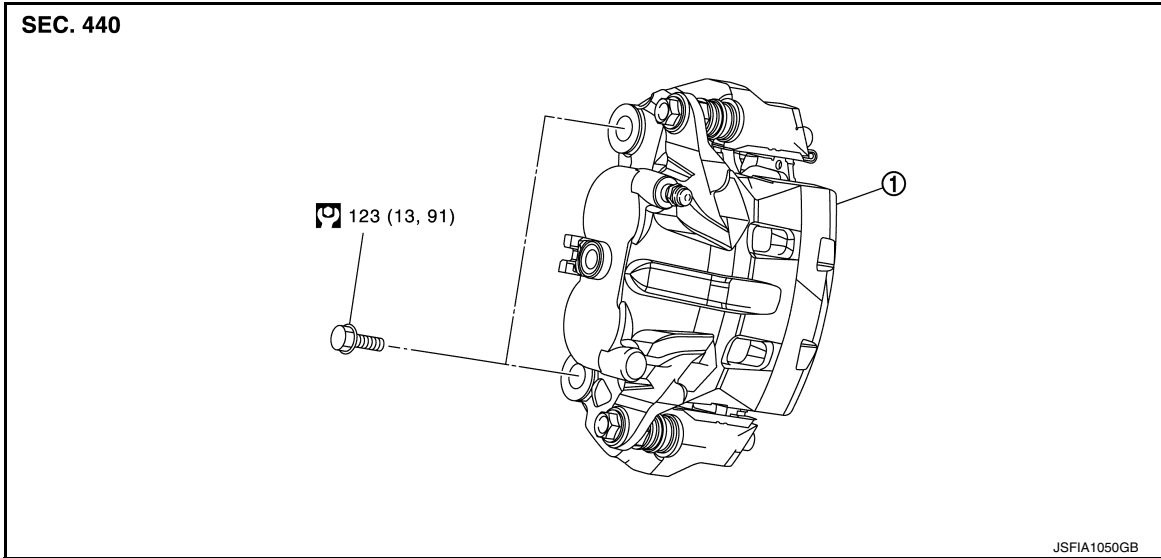

1. Brake caliper assembly

Refer to [GI-4, "Components"](#) for symbols in the figure.

DISASSEMBLY

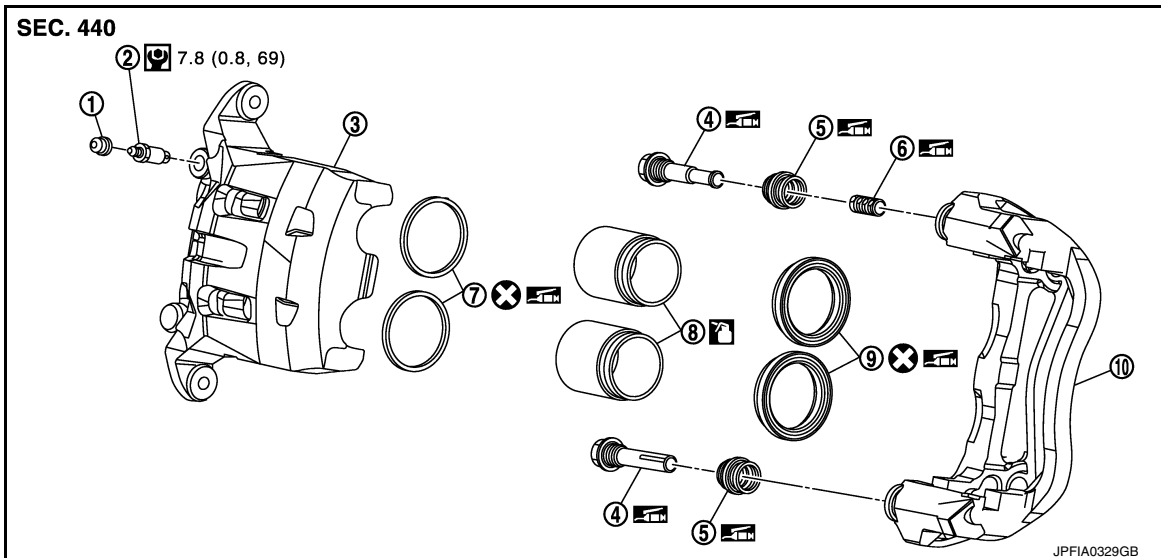

- | | | |
|-------------------|---------------------|------------------|
| 1. Cap | 2. Bleeder valve | 3. Cylinder body |
| 4. Sliding pin | 5. Sliding pin boot | 6. Bushing |
| 7. Piston seal | 8. Piston | 9. Piston boot |
| 10. Torque member | | |

: Apply rubber grease.

: Apply brake fluid.

Refer to [GI-4, "Components"](#) for symbols not described on the above.

BRAKE CALIPER ASSEMBLY (2 PISTON TYPE) : Removal and Installation

INFOID:000000010585155

REMOVAL

WARNING:

FRONT DISC BRAKE

< REMOVAL AND INSTALLATION >

Since dust covering the front brake has an affect on human body, the dust must be removed with a dust collector. Never splatter the dust with an air blow gun.

CAUTION:

Never depress the brake pedal. Brake fluid may splash while removing the brake hose.

1. Remove tires with power tool.
2. Fix the disc rotor using wheel nuts.
3. Drain brake fluid. Refer to [BR-12. "Draining"](#).

CAUTION:

Never spill or splash brake fluid on the disc rotor.

4. Remove union bolt and copper washer, and disconnect brake hose from caliper assembly. Refer to [BR-22. "FRONT : Exploded View"](#).
5. Remove torque member mounting bolts, and remove brake caliper assembly.

CAUTION:

Never drop brake pad and caliper assembly.

6. Remove disc rotor.

CAUTION:

- Put matching marks on the wheel hub and bearing assembly and the disc rotor before removing the disc rotor.
- Never drop disc rotor.

INSTALLATION

WARNING:

Since dust covering the front brake has an affect on human body, the dust must be removed with a dust collector. Never splatter the dust with an air blow gun.

CAUTION:

Never depress the brake pedal. Brake fluid may splash while removing the brake hose.

1. Install disc rotor.

CAUTION:

Align the matching marks that have been made during removal when reusing the disc rotor.

2. Install the brake caliper assembly to the vehicle and tighten the torque member mounting bolts to the specified torque.

CAUTION:

Never spill or splash any grease and moisture on the brake caliper assembly mounting face, threads, mounting bolts and washers. Wipe out any grease and moisture.

3. Install brake hose and copper washers to brake caliper assembly, and tighten union bolts to the specified torque. Refer to [BR-22. "FRONT : Exploded View"](#).

CAUTION:

Never reuse copper washer.

4. Refill with new brake fluid and perform the air bleeding. Refer to [BR-13. "Bleeding Brake System"](#).

CAUTION:

- Never reuse drained brake fluid.
- Never spill or splash brake fluid on the disc rotor.

5. Check a drag of front disc brake. If any drag is found, refer to [BR-49. "BRAKE CALIPER ASSEMBLY \(2 PISTON TYPE\) : Inspection"](#).

BRAKE CALIPER ASSEMBLY (2 PISTON TYPE) : Disassembly and Assembly

INFOID:000000010585156

DISASSEMBLY

NOTE:

Never remove the torque member and pad retainers when disassembling and assembling the cylinder body.

1. Remove the sliding pin bolt, and remove the cylinder body from the torque member. Refer to [BR-41. "BRAKE PAD \(2 PISTON TYPE\) : Exploded View"](#).

CAUTION:

Never drop brake pads, shims, shim covers and pad retainers from torque member.

2. Remove brake pads, shims and shim covers.
3. Remove sliding pins and sliding pin boots from torque member.

FRONT DISC BRAKE

< REMOVAL AND INSTALLATION >

4. Remove bushing from sliding pin.
5. Place a wooden block as shown in the figure, and blow air from union bolt mounting hole to remove pistons and piston boots.

CAUTION:

Never get fingers caught in the pistons.

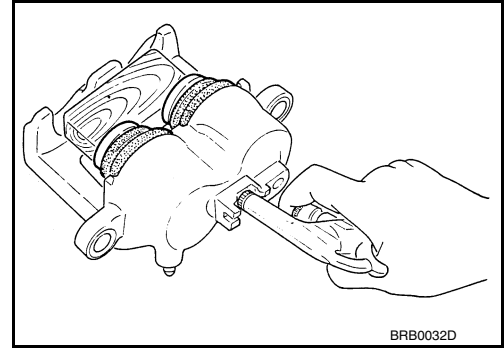

6. Remove piston seal from cylinder body using suitable tool.

CAUTION:

Be careful not to damage a cylinder inner wall.

7. Remove bleeder valve and cap.

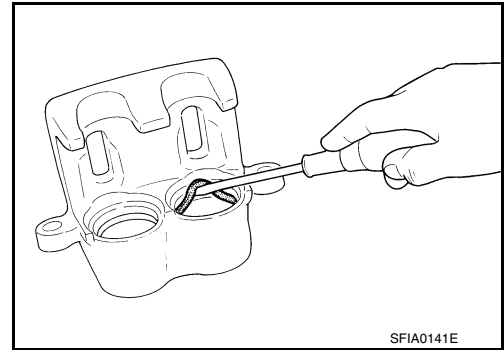

ASSEMBLY

1. Install bleeder valve and cap.
2. Apply rubber grease to piston seals (1), and install them to cylinder body.

CAUTION:

Never reuse piston seals.

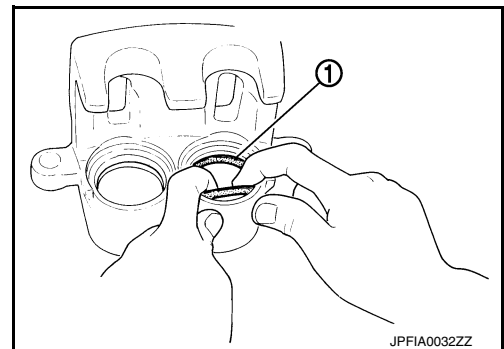

3. Apply rubber grease to piston boots (1). Cover the piston (2) end with piston boot, and then install cylinder side lip on piston boot securely into a groove on cylinder body.

CAUTION:

Never reuse piston boots.

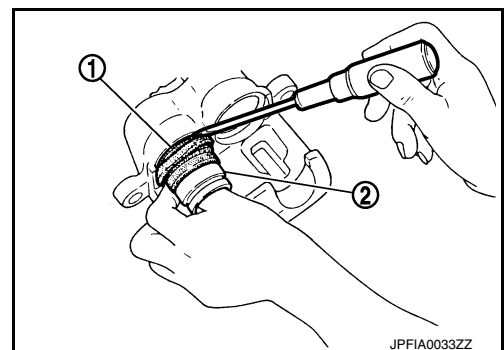

FRONT DISC BRAKE

< REMOVAL AND INSTALLATION >

4. Apply brake fluid to pistons (1). Push piston into cylinder body by hand and push piston boot (2) piston-side lip into the piston groove.

CAUTION:

Press the pistons evenly and vary the pressing point to prevent cylinder inner wall from being rubbed.

5. Apply rubber grease to bushing, and install bushing to sliding pin.
6. Apply rubber grease to sliding pins and sliding boots, and install sliding pins and sliding pin boots to torque member.
7. Install the cylinder body to the torque member and tighten the sliding pin bolts to the specified torque. Refer to [BR-41, "BRAKE PAD \(2 PISTON TYPE\) : Exploded View"](#).

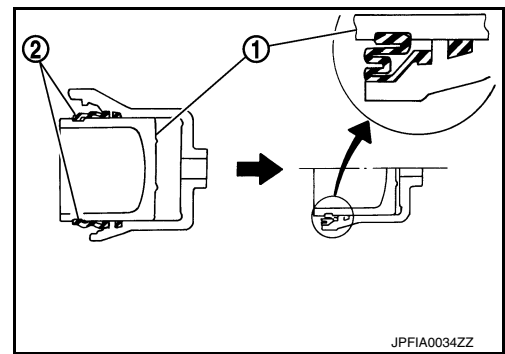

BRAKE CALIPER ASSEMBLY (2 PISTON TYPE) : Inspection

INFOID:000000010585157

INSPECTION AFTER DISASSEMBLY

Cylinder Body

Check the inner wall of the cylinder for rust, wear, cracks or damage. Replace the cylinder if any abnormal condition is detected.

CAUTION:

Always clean with new brake fluid. Never clean with mineral oil such as gasoline and light oil.

Torque Member

Check the torque member for rust, wear, cracks or damage. Replace the member if any abnormal condition is detected.

Pistons

Check the surface of the piston for rust, wear, cracks or damage. Replace the piston if any abnormal condition is detected.

CAUTION:

A piston sliding surface is plated. Never polish with sandpaper.

Sliding Pin and Sliding Pin Boot

Check the sliding pins and sliding boots for rust, wear, cracks or damage. Replace the parts if any abnormal condition is detected.

INSPECTION AFTER INSTALLATION

1. Check a drag of front disc brake. If any drag is found, follow the procedure described below.
2. Remove brake pads.
3. Press the pistons.

CAUTION:

 - Never damage the piston boot.
 - When replacing a pad with new one, check a brake fluid level in the reservoir tank because brake fluid returns to master cylinder reservoir tank when pressing piston in.

NOTE:

Use a disc brake piston tool to easily press piston.
4. Install brake pads.
5. Depress the brake pedal several times.
6. Check a drag of front disc brake again. If any drag is found, disassemble the cylinder body. Refer to [BR-47, "BRAKE CALIPER ASSEMBLY \(2 PISTON TYPE\) : Disassembly and Assembly"](#).
7. Burnish contact surface between disc rotor and brake pads after refinishing or replacing disc rotor, or if a soft pedal occurs at very low mileage. Refer to [BR-16, "DISC ROTOR : Inspection and Adjustment"](#).

BRAKE CALIPER ASSEMBLY (4 PISTON TYPE)

BRAKE CALIPER ASSEMBLY (4 PISTON TYPE) : Exploded View

INFOID:000000010585158

REMOVAL

FRONT DISC BRAKE

< REMOVAL AND INSTALLATION >

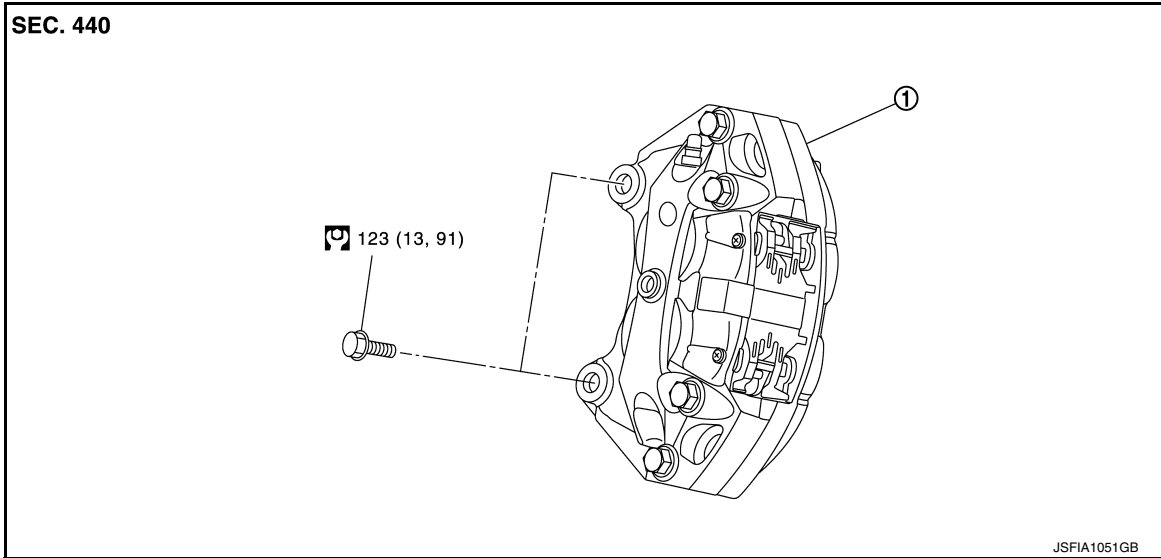

1. Caliper

Refer to [GI-4. "Components"](#) for symbols in the figure.

DISASSEMBLY

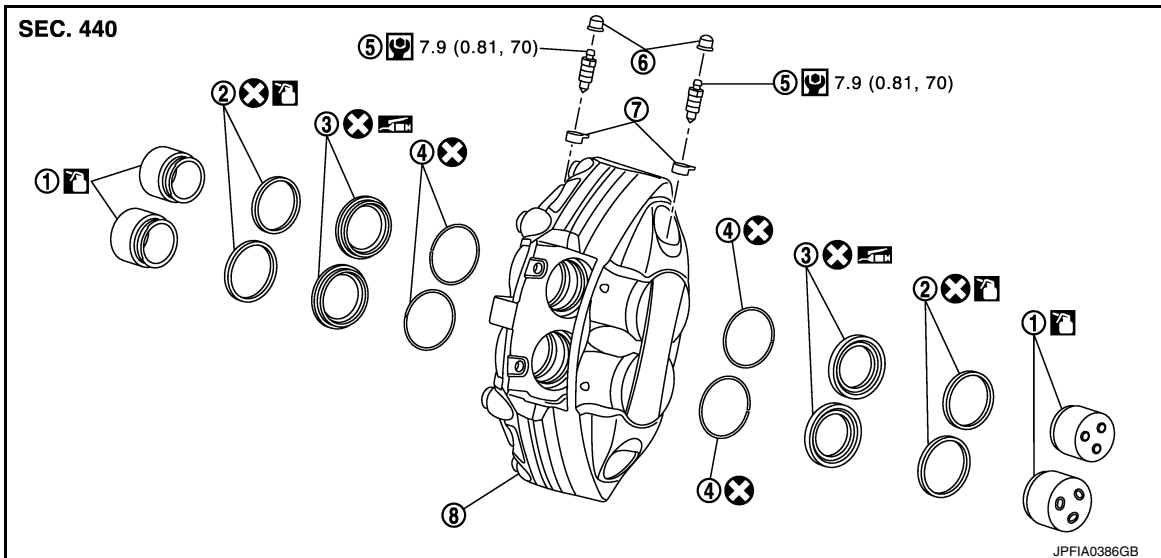

- | | | |
|-------------------|------------------|----------------|
| 1. Piston | 2. Piston seal | 3. Piston boot |
| 4. Retaining ring | 5. Bleeder Valve | 6. Cap |
| 7. Cap | 8. Caliper | |

: Apply rubber grease.

: Apply brake fluid.

Refer to [GI-4. "Components"](#) for symbols not described on the above.

BRAKE CALIPER ASSEMBLY (4 PISTON TYPE) : Removal and Installation

INFOID:000000010585159

REMOVAL

WARNING:

Since dust covering the front brake has an affect on human body, the dust must be removed with a dust collector. Never splatter the dust with an air blow gun.

CAUTION:

FRONT DISC BRAKE

< REMOVAL AND INSTALLATION >

Never depress the brake pedal. Brake fluid may splash while removing the brake hose and brake tube.

1. Remove tires with power tool. A
2. Fix the disc rotor using wheel nuts. B
3. Drain brake fluid. Refer to [BR-12. "Draining"](#). B
CAUTION:
Never spill or splash brake fluid on the disc rotor and caliper.
4. Loosen the flare nut with a flare nut wrench and separate the brake tube from caliper. C
CAUTION:
 - Cover flare nut wrench with a cloth as not to damage the caliper.
 - Never scratch the flare nut and the brake tube.
 - Never bend sharply, twist or strongly pull out the brake tube.
 - Cover open end of brake tube when disconnecting to prevent entrance of dirt.D
5. Remove caliper mounting bolts, and remove caliper. E
CAUTION:
Never drop brake pad and caliper.
6. Remove disc rotor. E
CAUTION:
 - Put matching marks on the wheel hub and bearing assembly and the disc rotor before removing the disc rotor.
 - Never drop disc rotor.BR

INSTALLATION G

WARNING:

Since dust covering the front brake has an affect on human body, the dust must be removed with a dust collector. Never splatter the dust with an air blow gun. H

CAUTION:

Never depress the brake pedal. Brake fluid may splash while removing the brake hose and brake tube.

1. Install disc rotor. I
CAUTION:
Align the matching marks that have been made during removal when reusing the disc rotor.
2. Install the brake caliper to the vehicle and tighten the caliper mounting bolts to the specified torque. J
CAUTION:
Never spill or splash any grease and moisture on the caliper mounting face, threads, mounting bolts and washers. Wipe out any grease and moisture.
3. Tighten the flare nut to the specified torque with a flare nut crowfoot and a torque wrench. K
CAUTION:
 - Cover crowfoot with a cloth as not to damage the caliper.
 - Never scratch the flare nut and the brake tube.L
4. Refill with new brake fluid and perform the air bleeding. Refer to [BR-13. "Bleeding Brake System"](#). M
CAUTION:
 - Never reuse drained brake fluid.
 - Never spill or splash brake fluid on the disc rotor and caliper.
5. Check a drag of front disc brake. If any drag is found, refer to [BR-53. "BRAKE CALIPER ASSEMBLY \(4 PISTON TYPE\) : Inspection"](#). N

BRAKE CALIPER ASSEMBLY (4 PISTON TYPE) : Disassembly and Assembly

INFOID:000000010585160

DISASSEMBLY O

1. Remove brake pads. Refer to [BR-43. "BRAKE PAD \(4 PISTON TYPE\) : Exploded View"](#). P
CAUTION:
Never drop brake pads, shims, pad pins and clips.
2. Remove caliper assembly. Refer to [BR-49. "BRAKE CALIPER ASSEMBLY \(4 PISTON TYPE\) : Exploded View"](#).

FRONT DISC BRAKE

< REMOVAL AND INSTALLATION >

3. Place a wooden block as shown in the figure, and blow air from union bolt mounting hole to remove pistons and piston boots and retaining rings.

CAUTION:

Never get fingers caught in the pistons.

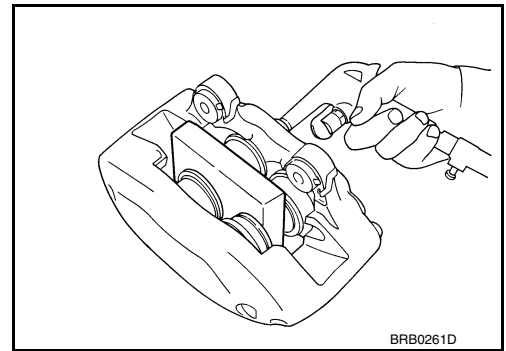

4. Remove piston seal (1) from cylinder body using suitable tool (A).

CAUTION:

Be careful not to damage a cylinder inner wall.

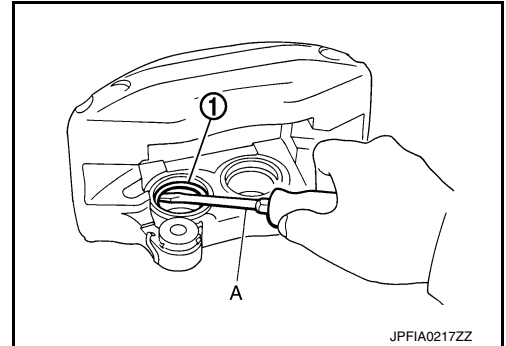

ASSEMBLY

1. Apply brake fluid to piston seals (1), and install them to caliper.

CAUTION:

Never reuse piston seals.

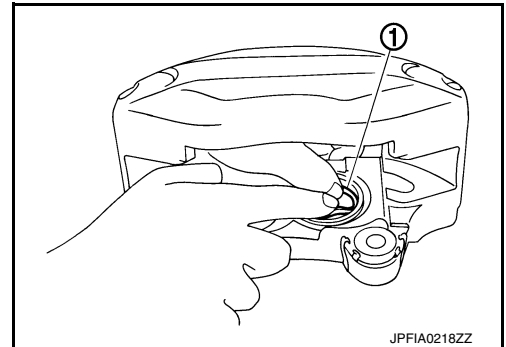

FRONT DISC BRAKE

< REMOVAL AND INSTALLATION >

2. Apply rubber grease to piston boots (1). Cover the piston (2) end with piston boots, and then install caliper side lip on piston boot securely into a groove on caliper.

CAUTION:

Never reuse piston boots.

3. Apply brake fluid to piston. Push piston into caliper by hand and push piston boot piston-side lip into the piston groove.

CAUTION:

Press the piston evenly and vary the pressing point to prevent caliper inner wall from being rubbed.

4. Secure piston boot with retaining ring.

CAUTION:

- Make sure that boot is securely engaged in the groove on caliper.
- Never reuse retaining ring.

5. Install the caliper to tighten the caliper mounting bolts to the specified torque. Refer to [BR-49, "BRAKE CALIPER ASSEMBLY \(4 PISTON TYPE\) : Exploded View"](#).

6. Install brake pads. Refer to [BR-43, "BRAKE PAD \(4 PISTON TYPE\) : Exploded View"](#).

CAUTION:

Never drop brake pads, shims, pad pins and clips.

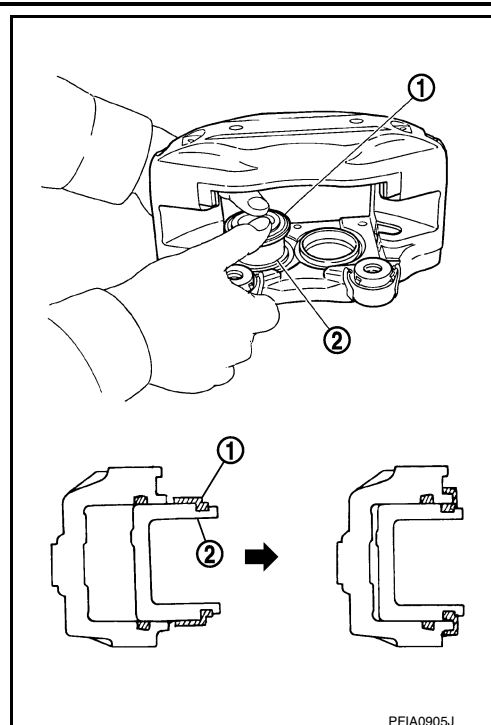

BRAKE CALIPER ASSEMBLY (4 PISTON TYPE) : Inspection

INFOID:000000010585161

INSPECTION AFTER DISASSEMBLY

Caliper

Check the inner wall of the caliper for rust, wear, cracks or damage. Replace the caliper if any abnormal condition is detected.

CAUTION:

Always clean with new brake fluid. Never clean with mineral oil such as gasoline and light oil.

Pistons

Check the surface of the piston for rust, wear, cracks or damage. Replace the piston if any abnormal condition is detected.

CAUTION:

A piston sliding surface is plated. Never polish with sandpaper.

INSPECTION AFTER INSTALLATION

1. Check a drag of front disc brake. If any drag is found, follow the procedure described below.

2. Remove brake pads.

3. Press the pistons.

CAUTION:

- Never damage the piston boot.
- When replacing a pad with new one, check a brake fluid level in the reservoir tank because brake fluid returns to master cylinder reservoir tank when pressing piston in.

NOTE:

Use a disc brake piston tool to easily press piston.

4. Install brake pads.

5. Depress the brake pedal several times.

6. Check a drag of front disc brake again. If any drag is found, disassemble the cylinder body. Refer to [BR-51, "BRAKE CALIPER ASSEMBLY \(4 PISTON TYPE\) : Disassembly and Assembly"](#).

7. Burnish contact surface between disc rotor and brake pads after refinishing or replacing disc rotor, or if a soft pedal occurs at very low mileage. Refer to [BR-16, "DISC ROTOR : Inspection and Adjustment"](#).

REAR DISC BRAKE

< REMOVAL AND INSTALLATION >

REAR DISC BRAKE BRAKE PAD (1 PISTON TYPE)

BRAKE PAD (1 PISTON TYPE) : Exploded View

INFOID:000000010585162

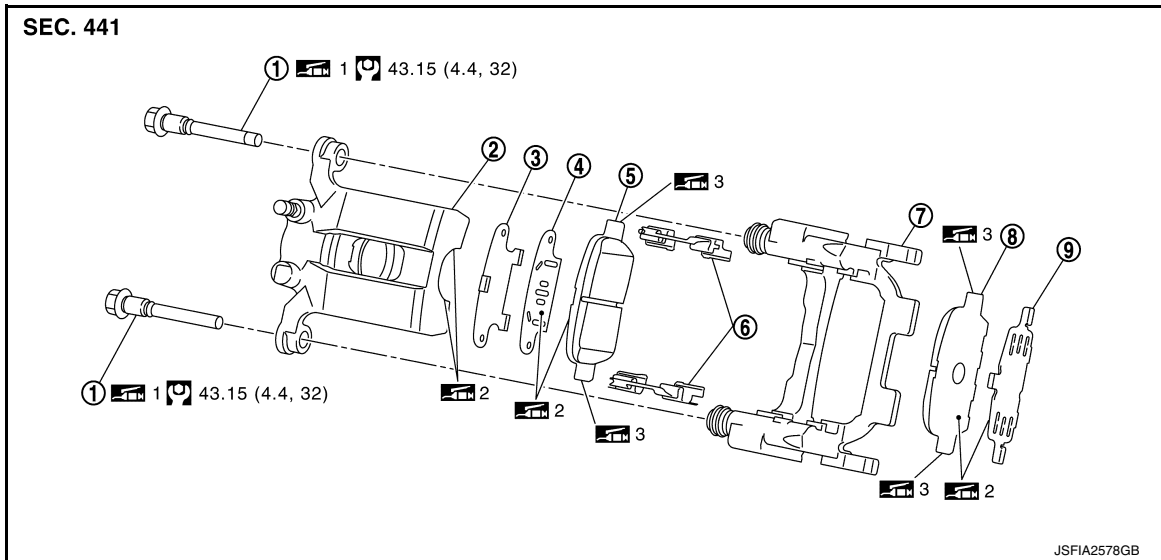

- | | | |
|---------------------|-------------------------------------|---------------------|
| 1. Sliding pin bolt | 2. Cylinder body | 3. Inner shim cover |
| 4. Inner shim | 5. Inner pad (with pad wear sensor) | 6. Pad retainer |
| 7. Torque member | 8. Outer pad | 9. Outer shim |

1: Apply rubber grease.

2: Apply MOLYKOTE® AS880N or silicone-based grease.

3: Apply MOLYKOTE® 7439 or equivalent.

Refer to [GI-4. "Components"](#) for symbols not described on the above.

Molykote is a registered trademark of Dow Corning Corporation.

BRAKE PAD (1 PISTON TYPE) : Removal and Installation

INFOID:000000010585163

REMOVAL

WARNING:

Since dust covering the rear brake has an affect on human body, the dust must be removed with a dust collector. Never splatter the dust with an air blow gun.

CAUTION:

- Never depress the brake pedal while removing the brake pads or the cylinder body because the piston may pop out.
- Never spill or splash brake fluid on the disc rotor.

1. Remove tires with power tool.
2. Remove the upper sliding pin bolt.
3. Suspend the cylinder body with a wire so that the brake hose will not stretch. Remove the brake pads, shims, shim cover and pad retainers from the torque member.

CAUTION:

- Never deform the pad retainers if removing the pad retainers.
- Never damage the piston boot.
- Never drop the brake pad, shims, and the shim cover.
- Remember each position of the removed brake pads.

INSTALLATION

WARNING:

REAR DISC BRAKE

< REMOVAL AND INSTALLATION >

Since dust covering the rear brake has an affect on human body, the dust must be removed with a dust collector. Never splatter the dust with an air blow gun.

CAUTION:

- Never depress the brake pedal while removing the brake pads or the cylinder body because the piston may pop out.
- Never spill or splash brake fluid on the disc rotor.

1. Apply MOLYKOTE[®] 7439 or equivalent to the pad retainers before installing it to the torque member if the pad retainers has been removed.

CAUTION:

- Securely assemble the pad retainers so that it will not be lifted up from the torque member.
- Never deform the pad retainers.

Molykote is a registered trademark of Dow Corning Corporation.

2. Apply MOLYKOTE[®] AS880N or silicone-based grease to the mating faces between the shims and the shim cover.

CAUTION:

Always replace the shims together with the shim cover when replacing the brake pad.

Molykote is a registered trademark of Dow Corning Corporation.

3. Apply MOLYKOTE[®] AS880N or silicone-based grease to the mating faces between the brake pads and pad retainers and install them to the brake pads.

Molykote is a registered trademark of Dow Corning Corporation.

4. Install cylinder body and brake pads to torque member.

CAUTION:

- Never damage the piston boot.
- When replacing brake pad with new one, check a brake fluid level in the reservoir tank because brake fluid returns to master cylinder reservoir tank when pressing piston in.

NOTE:

Use a disc brake piston tool to easily press piston.

5. Install the upper sliding pin bolt and tighten it to the specified torque.
6. Depress the brake pedal several times to check that no drag feel is present for the rear disc brake. Refer to [BR-55, "BRAKE PAD \(1 PISTON TYPE\) : Inspection"](#).

BRAKE PAD (1 PISTON TYPE) : Inspection

INFOID:000000010585164

INSPECTION AFTER REMOVAL

Replace the shims and the shim cover if rust is excessively attached.

INSPECTION AFTER INSTALLATION

1. Check a drag of rear disc brake. If any drag is found, follow the procedure described below.
2. Remove brake pads.
3. Press the pistons.
CAUTION:
 - Never damage the piston boot.
 - When replacing a pad with new one, check a brake fluid level in the reservoir tank because brake fluid returns to master cylinder reservoir tank when pressing piston in.
- NOTE:**

Use a disc brake piston tool to easily press piston.
4. Install brake pads.
5. Depress the brake pedal several times.
6. Check a drag of rear disc brake again. If any drag is found, disassemble the cylinder body. Refer to [BR-60, "BRAKE CALIPER ASSEMBLY \(1 PISTON TYPE\) : Disassembly and Assembly"](#).
7. Burnish contact surface between brake pads and disc rotor after refinishing or replacing brake pads, or if a soft pedal occurs at very low mileage. Refer to [BR-18, "BRAKE PAD : Inspection and Adjustment"](#).

BRAKE PAD (2 PISTON TYPE)

REAR DISC BRAKE

< REMOVAL AND INSTALLATION >

BRAKE PAD (2 PISTON TYPE) : Exploded View

INFOID:000000010585165

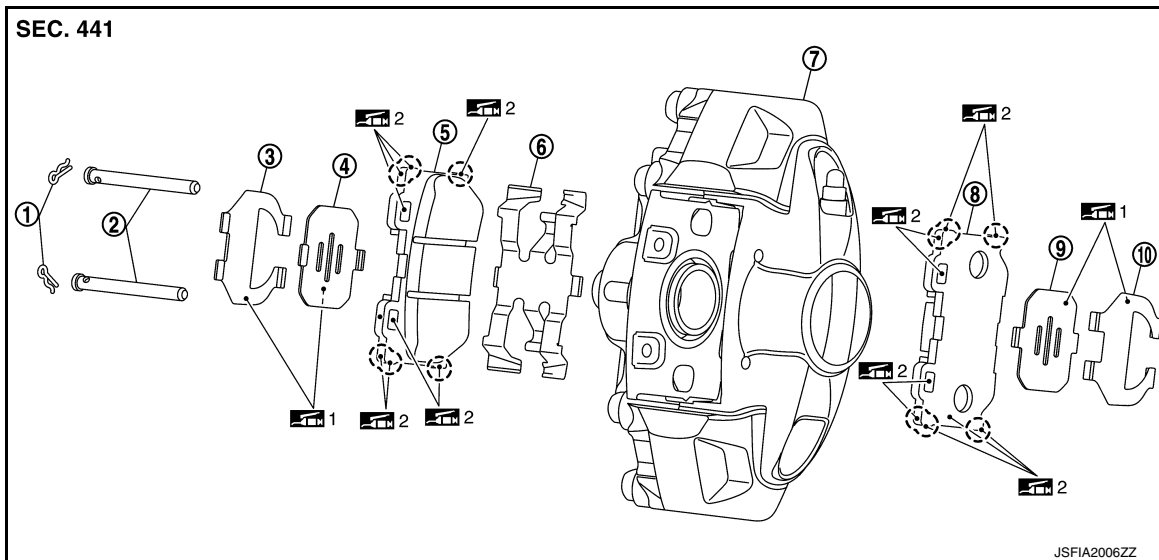

- | | | |
|----------------------|-------------------------------------|---------------------|
| 1. Clip | 2. Pad pin | 3. Inner shim cover |
| 4. Inner shim | 5. Inner pad (with pad wear sensor) | 6. Cross spring |
| 7. Caliper | 8. Outer pad | 9. Outer shim |
| 10. Outer shim cover | | |

 1: Apply MOLYKOTE® AS880N or silicone-based grease.

 2: Apply MOLYKOTE® 7439 or equivalent.

Refer to [GI-4, "Components"](#) for symbols not described on the above.

Molykote is a registered trademark of Dow Corning Corporation.

BRAKE PAD (2 PISTON TYPE) : Removal and Installation

INFOID:000000010585166

REMOVAL

WARNING:

Since dust covering the rear brake has an affect on human body, the dust must be removed with a dust collector. Never splatter the dust with an air blow gun.

CAUTION:

- Never depress the brake pedal while removing the brake pads or the cylinder body because the piston may pop out.
- Never spill or splash brake fluid on the disc rotor and caliper.

1. Remove tires with power tool.
2. Remove clips from pad pins.

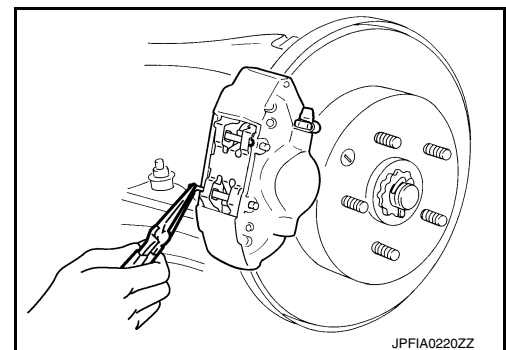

REAR DISC BRAKE

< REMOVAL AND INSTALLATION >

3. Remove pad pins while holding down cross spring, then remove cross spring from caliper.

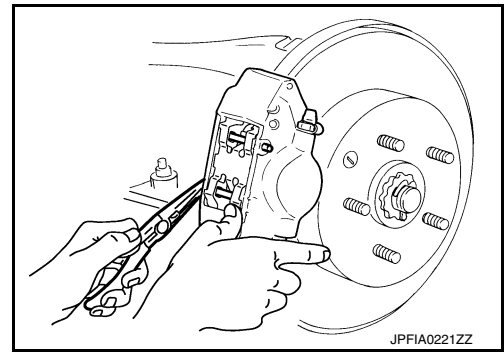

4. Using pliers, remove brake pads, shims and shim covers from caliper.

CAUTION:

- Never damage the piston boot.
- Never drop the brake pad, shims, and the shim cover.
- Remember each position of the removed brake pads.

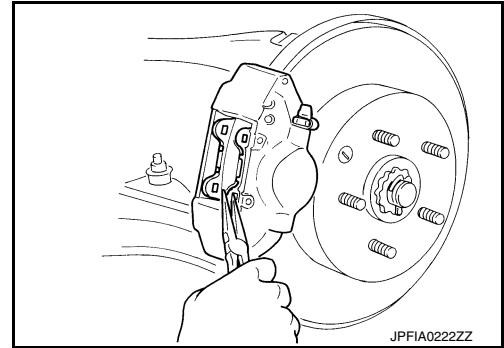

INSTALLATION

WARNING:

Since dust covering the rear brake has an affect on human body, the dust must be removed with a dust collector. Never splatter the dust with an air blow gun.

CAUTION:

- Never depress the brake pedal while removing the brake pads because the piston may pop out.
- Never spill or splash brake fluid on the disc rotor and caliper.

1. Apply MOLYKOTE[®] AS880N or silicone-based grease to the mating faces between the brake pads, shims and shim cover, and install shims and shim cover to the brake pad.

CAUTION:

Always replace the shims together when replacing the brake pad.

Molykote is a registered trademark of Dow Corning Corporation.

2. Apply MOLYKOTE[®] 7439 or equivalent to the mating faces between the brake pads and caliper. Molykote is a registered trademark of Dow Corning Corporation.
3. Apply MOLYKOTE[®] 7439 or equivalent to the mating faces between the brake pads and pad pins. Molykote is a registered trademark of Dow Corning Corporation.
4. Apply MOLYKOTE[®] 7439 or equivalent to the mating faces between the brake pads and cross spring. Molykote is a registered trademark of Dow Corning Corporation.

5. Install brake pads to caliper.

CAUTION:

- Never damage the piston boot.
- In the case of replacing a pad with new one, check a brake fluid level in the reservoir tank because brake fluid returns to master cylinder reservoir tank when pressing piston in.

NOTE:

Use a disc brake piston tool to easily press piston.

6. Install upper pad pin from the inner side, then install firmly to the outer side through the hole in the top of brake pad.

A
B
C
D
E
BR
G
H
I
J
K
L
M
N
O
P

REAR DISC BRAKE

< REMOVAL AND INSTALLATION >

- Place the top of cross spring over the upper pad pin, press in the cross spring, install lower pad pin from the inner side to the outer side, and secure cross spring.
- Install clips to the pad pins.
CAUTION:
If clip is not fully attached, pad pin or brake pad could fall out while vehicle is in motion.
- Depress the brake pedal several times to check that no drag feel is present for the rear disc brake. Refer to [BR-58, "BRAKE PAD \(2 PISTON TYPE\) : Inspection"](#).

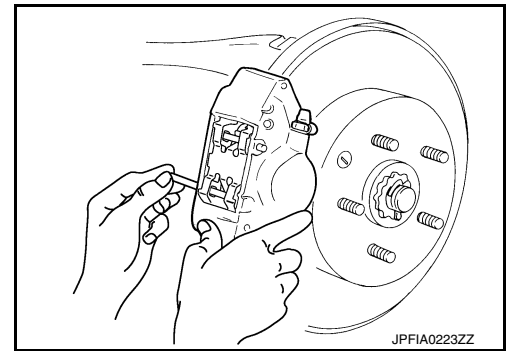

BRAKE PAD (2 PISTON TYPE) : Inspection

INFOID:000000010585167

INSPECTION AFTER REMOVAL

Replace the shims and shim cover if rust is excessively attached.

INSPECTION AFTER INSTALLATION

- Check a drag of rear disc brake. If any drag is found, follow the procedure described below.
- Remove brake pads.
- Press the pistons.
CAUTION:
 - Never damage the piston boot.
 - When replacing a pad with new one, check a brake fluid level in the reservoir tank because brake fluid returns to master cylinder reservoir tank when pressing piston in.**NOTE:**
Use a disc brake piston tool to easily press piston.
- Install brake pads.
- Depress the brake pedal several times.
- Check a drag of rear disc brake again. If any drag is found, disassemble the cylinder body. Refer to [BR-65, "BRAKE CALIPER ASSEMBLY \(2 PISTON TYPE\) : Disassembly and Assembly"](#).
- Burnish contact surface between brake pads and disc rotor after refinishing or replacing brake pads, or if a soft pedal occurs at very low mileage. Refer to [BR-18, "BRAKE PAD : Inspection and Adjustment"](#).

BRAKE CALIPER ASSEMBLY (1 PISTON TYPE)

BRAKE CALIPER ASSEMBLY (1 PISTON TYPE) : Exploded View

INFOID:000000010585168

REMOVAL

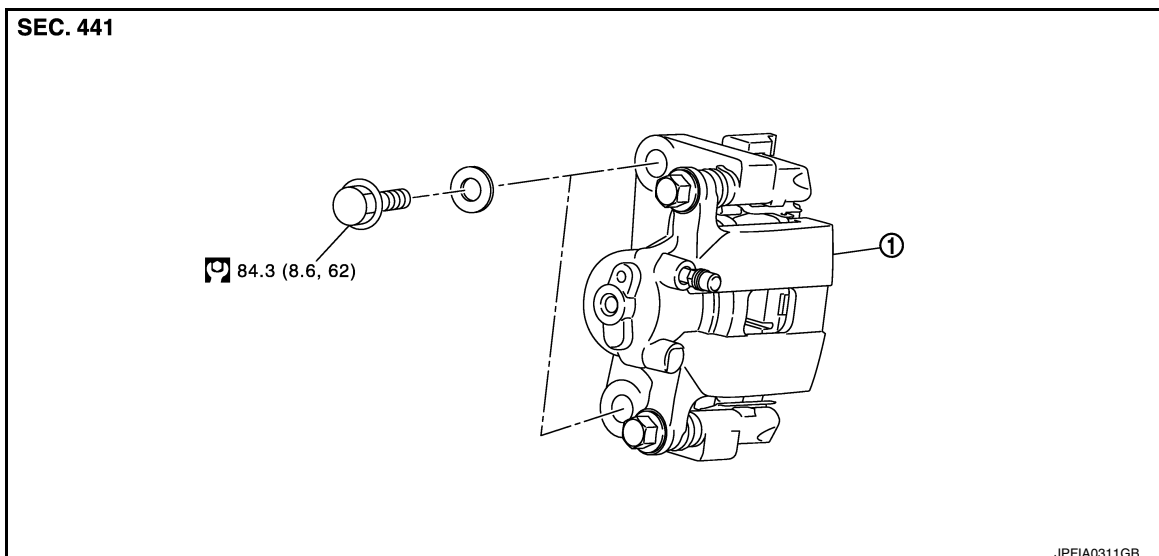

REAR DISC BRAKE

< REMOVAL AND INSTALLATION >

1. Brake caliper assembly

Refer to [GI-4, "Components"](#) for symbols not described on the above.

DISASSEMBLY

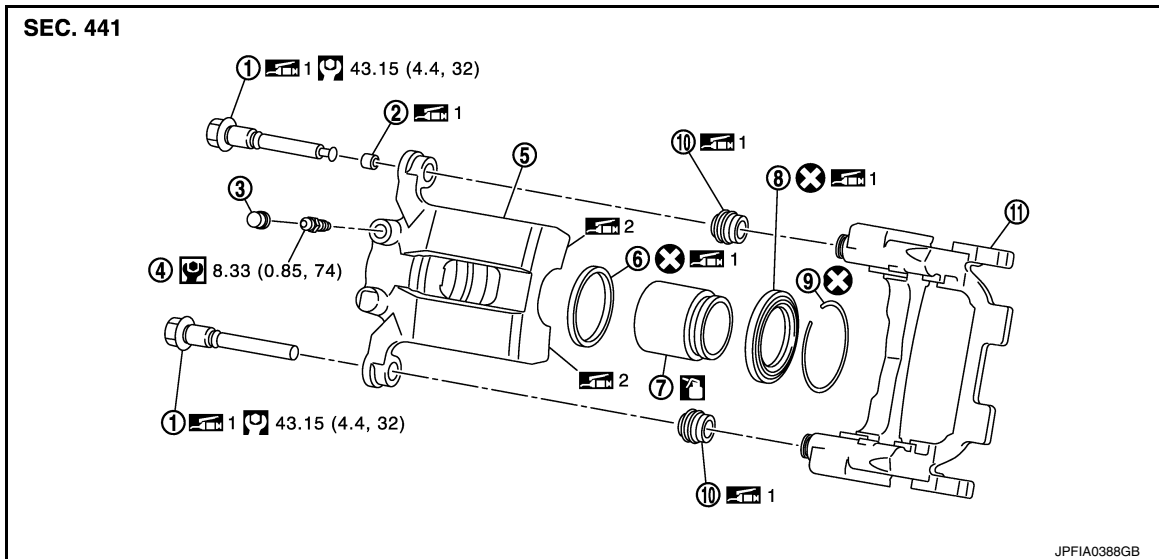

- | | | |
|----------------------|-------------------|-------------------|
| 1. Sliding pin bolt | 2. Bushing | 3. Cap |
| 4. Bleeder valve | 5. Cylinder body | 6. Piston seal |
| 7. Piston | 8. Piston boot | 9. Retaining ring |
| 10. Sliding pin boot | 11. Torque member | |

1: Apply rubber grease.

2: Apply MOLYKOTE® AS880N or silicone-based grease.

: Apply brake fluid.

Refer to [GI-4, "Components"](#) for symbols not described on the above.

Molykote is a registered trademark of Dow Corning Corporation.

BRAKE CALIPER ASSEMBLY (1 PISTON TYPE) : Removal and Installation

INFOID:000000010585169

REMOVAL

WARNING:

Since dust covering the rear brake has an affect on human body, the dust must be removed with a dust collector. Never splatter the dust with an air blow gun.

CAUTION:

Never depress the brake pedal. Brake fluid may splash while removing the brake hose.

1. Remove tires with power tool.
2. Fix the disc rotor using wheel nuts.
3. Drain brake fluid. Refer to [BR-12, "Draining"](#).
CAUTION:
Never spill or splash brake fluid on the disc rotor.
4. Remove union bolt and copper washers, and disconnect brake hose from caliper assembly.
5. Remove torque member mounting bolts, and remove brake caliper assembly.
CAUTION:
Never drop brake pad and caliper assembly.
6. Remove disc rotor.
CAUTION:

REAR DISC BRAKE

< REMOVAL AND INSTALLATION >

- Put matching marks on the wheel hub and bearing assembly and the disc rotor before removing the disc rotor.
- Never drop disc rotor.

INSTALLATION

WARNING:

Since dust covering the rear brake has an affect on human body, the dust must be removed with a dust collector. Never splatter the dust with an air blow gun.

CAUTION:

Never depress the brake pedal. Brake fluid may splash while removing the brake hose.

1. Install disc rotor.

CAUTION:

Align the matching marks that have been made during removal when reusing the disc rotor.

2. Install the brake caliper assembly to the vehicle and tighten the torque member mounting bolts to the specified torque.

CAUTION:

Never spill or splash any grease and moisture on the brake caliper assembly mounting face, threads, mounting bolts, and washers. Wipe out any grease and moisture.

3. Install brake hose and copper washers to brake caliper assembly, and tighten union bolts to the specified torque. Refer to [BR-26, "REAR : Exploded View"](#).
4. Refill with new brake fluid and perform the air bleeding. Refer to [BR-13, "Bleeding Brake System"](#).

CAUTION:

- Never reuse drained brake fluid.
- Never spill or splash brake fluid on the disc rotor.

5. Check a drag of rear disc brake. If any drag is found, refer to [BR-62, "BRAKE CALIPER ASSEMBLY \(1 PISTON TYPE\) : Inspection"](#).

BRAKE CALIPER ASSEMBLY (1 PISTON TYPE) : Disassembly and Assembly

INFOID:000000010585170

DISASSEMBLY

NOTE:

Never remove torque member and pad retainers when disassembling and assembling the cylinder body.

1. Remove sliding pin bolts and remove the cylinder body from the torque member.
2. Remove brake pads, shims and shim cover. Refer to [BR-54, "BRAKE PAD \(1 PISTON TYPE\) : Exploded View"](#).
3. Remove sliding pin boots from torque member.
4. Remove bushing from sliding pin bolt.
5. Remove retaining ring (1) from cylinder body using suitable tool as shown in the figure.

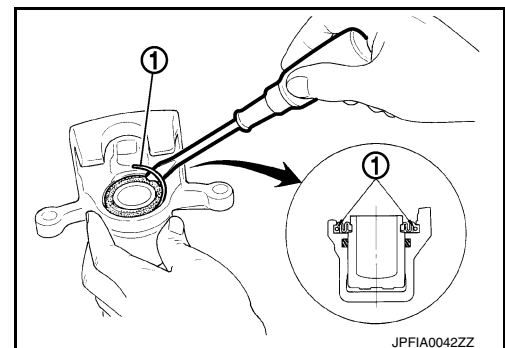

JPFIA0042ZZ

REAR DISC BRAKE

< REMOVAL AND INSTALLATION >

- Place a wooden block as shown in the figure, and blow air from union bolt mounting hole to remove piston and piston boot.

CAUTION:

Never get fingers caught in the piston.

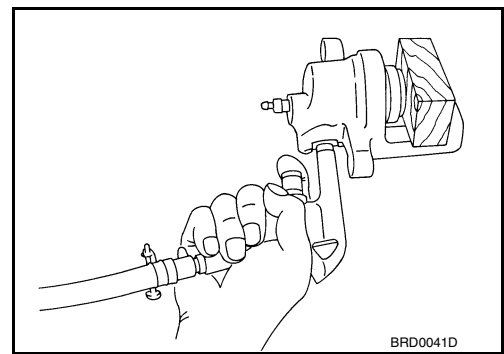

- Remove piston seal from cylinder body using suitable tool.

CAUTION:

Be careful not to damage a cylinder inner wall.

- Remove bleeder valve and cap.

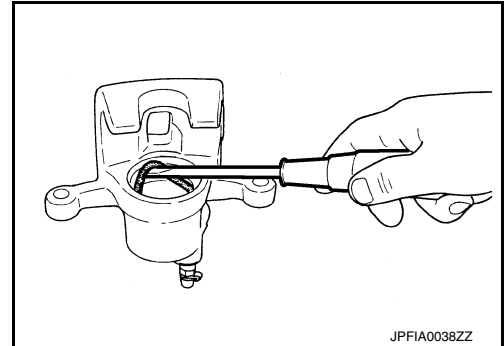

ASSEMBLY

- Install bleeder valve and cap.
- Apply rubber grease to piston seal (1), and install them to cylinder body.

CAUTION:

Never reuse piston seal.

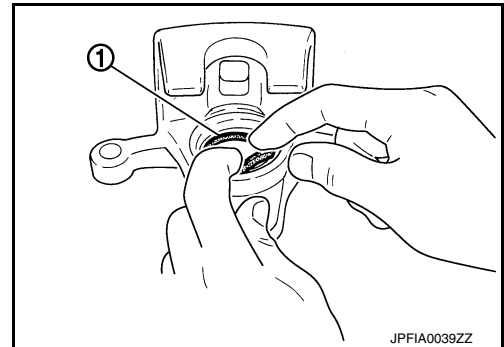

- Apply rubber grease to piston boot (1). Cover the piston (2) end with the piston boot, and then install cylinder side lip on the piston boot securely into the groove on cylinder body.

CAUTION:

Never reuse piston boot.

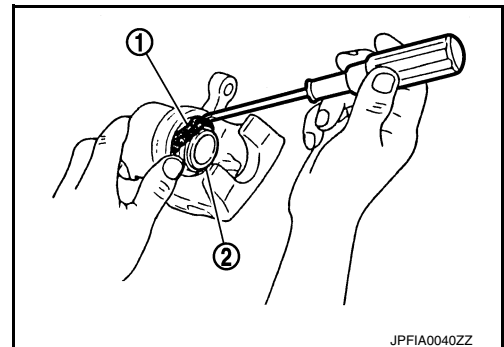

A
B
C
D
E
BR
G
H
I
J
K
L
M
N
O
P

REAR DISC BRAKE

< REMOVAL AND INSTALLATION >

4. Apply brake fluid to piston (1). Push piston into cylinder body by hand and push piston boot (2) piston side lip into the piston groove.

CAUTION:

Press the piston evenly and vary the pressing point to prevent cylinder inner wall from being rubbed.

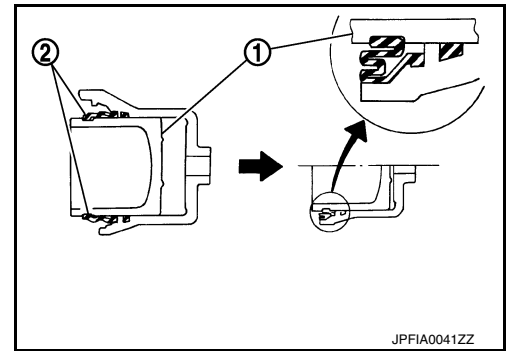

5. Secure piston boot with retaining ring (1).

CAUTION:

- **Make sure that boot is securely engaged in the groove on cylinder body.**
- **Never reuse retaining ring.**

6. Apply rubber grease to bushing, and install bushing to sliding pin bolt.
7. Apply rubber grease to sliding pin boots, and install sliding pin boot to torque member.
8. Apply rubber grease to sliding pin bolts, and install the cylinder body to the torque member and tighten the sliding pin bolt to the specified torque.
9. Install radius rod. Refer to [RSU-14, "Exploded View"](#).

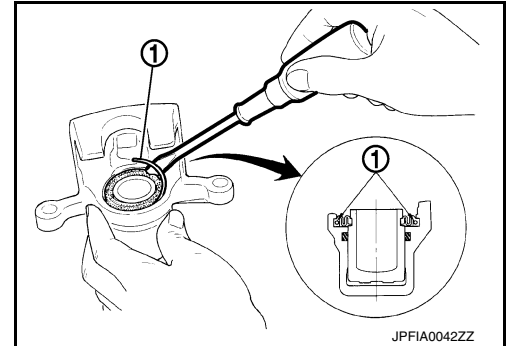

BRAKE CALIPER ASSEMBLY (1 PISTON TYPE) : Inspection

INFOID:000000010585171

INSPECTION AFTER DISASSEMBLY

Cylinder Body

Check the inner wall of the cylinder for rust, wear, cracks or damage. Replace the cylinder if any abnormal condition is detected.

CAUTION:

Always clean with new brake fluid. Never clean with mineral oil such as gasoline and light oil.

Torque Member

Check the torque member for rust, wear, cracks or damage. Replace the member if any abnormal condition is detected.

Piston

Check the piston for rust, wear, cracks or damage. Replace the piston if any abnormal condition is detected.

CAUTION:

A piston sliding surface is plated. Never polish with sandpaper.

Sliding Pin Bolt and Sliding Pin Boot

Check the sliding pin bolts and sliding pin boots for rust, wear, cracks or damage. Replace the parts if any abnormal condition is detected.

INSPECTION AFTER INSTALLATION

1. Check a drag of rear disc brake. If any drag is found, follow the procedure described below.
2. Remove brake pads.
3. Press the pistons.

CAUTION:

 - **Never damage the piston boot.**
 - **When replacing a pad with new one, check a brake fluid level in the reservoir tank because brake fluid returns to master cylinder reservoir tank when pressing piston in.**

NOTE:

Use a disc brake piston tool to easily press piston.
4. Install brake pads.

REAR DISC BRAKE

< REMOVAL AND INSTALLATION >

5. Depress the brake pedal several times.
6. Check a drag of rear disc brake again. If any drag is found, disassemble the cylinder body.
7. Burnish contact surface between disc rotor and brake pads after refinishing or replacing disc rotor, or if a soft pedal occurs at very low mileage. Refer to [BR-18. "DISC ROTOR : Inspection and Adjustment"](#).

BRAKE CALIPER ASSEMBLY (2 PISTON TYPE)

BRAKE CALIPER ASSEMBLY (2 PISTON TYPE) : Exploded View

INFOID:000000010585172

REMOVAL

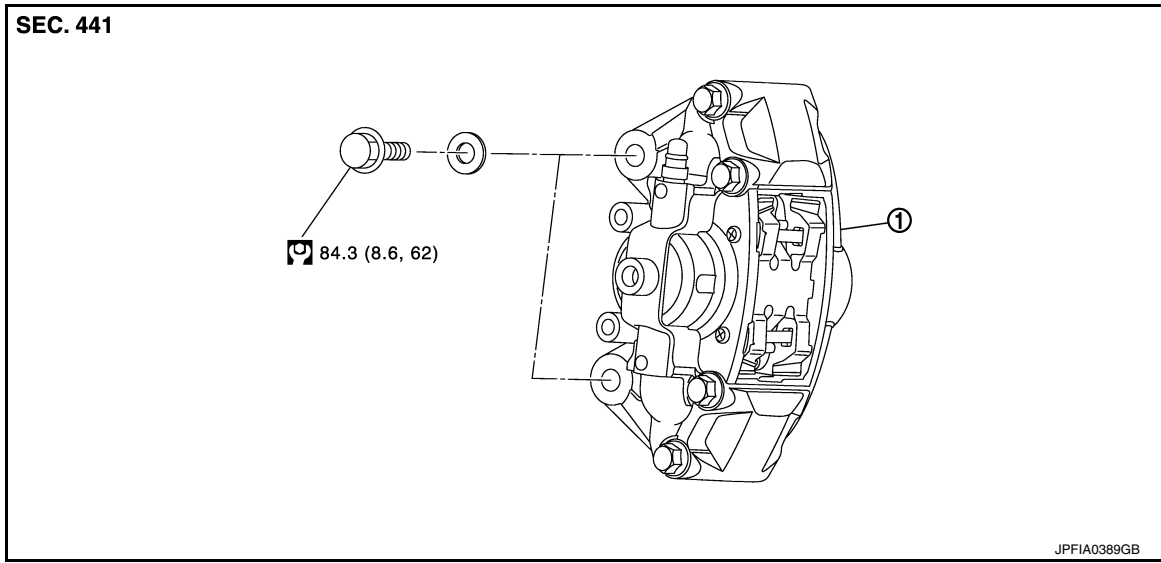

1. Caliper assembly

Refer to [GI-4. "Components"](#) for symbols in the figure.

DISASSEMBLY

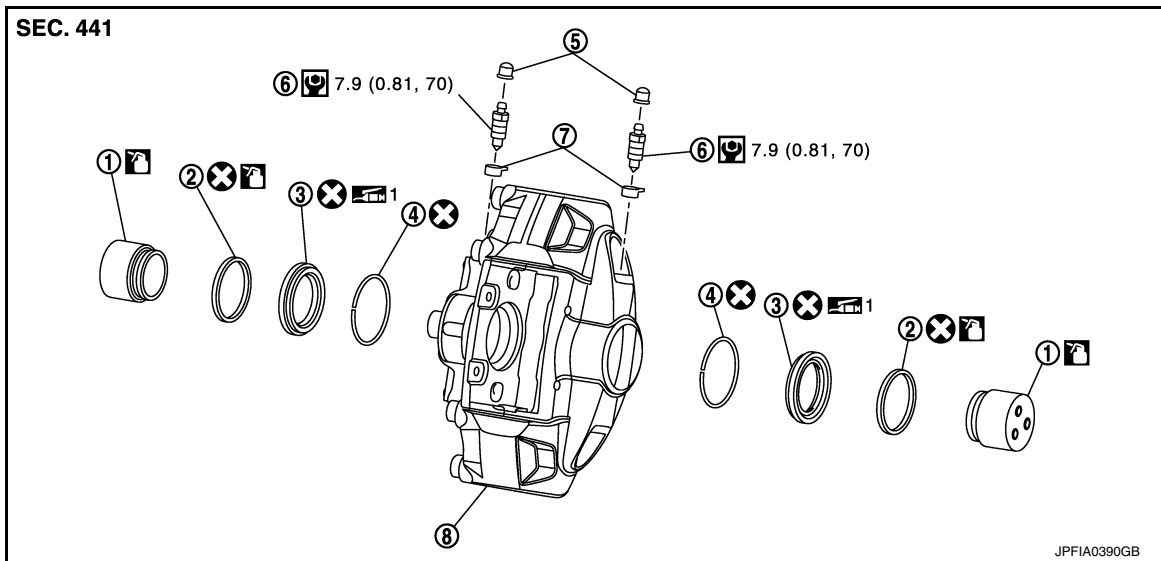

- | | | |
|-------------------|----------------|------------------|
| 1. Piston | 2. Piston seal | 3. Piston boot |
| 4. Retaining ring | 5. Cap | 6. Bleeder valve |
| 7. Cap | 8. Caliper | |

1: Apply rubber grease.

REAR DISC BRAKE

< REMOVAL AND INSTALLATION >

 Apply brake fluid.

Refer to [GI-4, "Components"](#) for symbols not described on the above.

BRAKE CALIPER ASSEMBLY (2 PISTON TYPE) : Removal and Installation

INFOID:000000010585173

REMOVAL

WARNING:

Since dust covering the rear brake has an affect on human body, the dust must be removed with a dust collector. Never splatter the dust with an air blow gun.

CAUTION:

Never depress the brake pedal. Brake fluid may splash while removing the brake hose and brake tube.

1. Remove tires with power tool.
2. Fix the disc rotor using wheel nuts.
3. Drain brake fluid. Refer to [BR-12, "Draining"](#).

CAUTION:

Never spill or splash brake fluid on the disc rotor.

4. Loosen the flare nut with a flare nut wrench and separate the brake tube from caliper.

CAUTION:

- Cover flare nut wrench with a cloth as not to damage the caliper.
- Never scratch the flare nut and the brake tube.
- Never bend sharply, twist or strongly pull out the brake tube.
- Cover open end of brake tube when disconnecting to prevent entrance of dirt.

5. Remove brake hose mounting bolt.
6. Remove caliper mounting bolts, and remove caliper.

CAUTION:

Never drop brake pad and caliper.

7. Remove disc rotor.

CAUTION:

- Put matching marks on the wheel hub and bearing assembly and the disc rotor before removing the disc rotor.
- Never drop disc rotor.

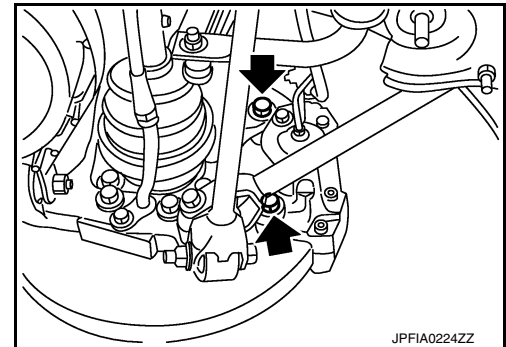

INSTALLATION

WARNING:

Since dust covering the rear brake has an affect on human body, the dust must be removed with a dust collector. Never splatter the dust with an air blow gun.

CAUTION:

Never depress the brake pedal. Brake fluid may splash while removing the brake hose.

1. Install disc rotor.

CAUTION:

Align the matching marks that have been made during removal when reusing the disc rotor.

2. Install the brake caliper to the vehicle and tighten the caliper mounting bolts to the specified torque.

CAUTION:

Never spill or splash any grease and moisture on the caliper mounting face, threads, mounting bolts and washers. Wipe out any grease and moisture.

3. Install the brake hose mounting bolt to the specified torque.
4. Tighten the flare nut to the specified torque with a flare nut crowfoot and a torque wrench.

CAUTION:

- Cover crowfoot with a cloth as not to damage the caliper.
- Never scratch the flare nut and the brake tube.

5. Refill with new brake fluid and perform the air bleeding. Refer to [BR-13, "Bleeding Brake System"](#).

CAUTION:

- Never reuse drained brake fluid.

REAR DISC BRAKE

< REMOVAL AND INSTALLATION >

- **Never spill or splash brake fluid on the disc rotor.**

6. Check a drag of rear disc brake. If any drag is found, refer to [BR-66. "BRAKE CALIPER ASSEMBLY \(2 PISTON TYPE\) : Inspection"](#).

BRAKE CALIPER ASSEMBLY (2 PISTON TYPE) : Disassembly and Assembly

INFOID:0000000110585174

DISASSEMBLY

1. Remove brake pads. Refer to [BR-56. "BRAKE PAD \(2 PISTON TYPE\) : Exploded View"](#).

CAUTION:

Never drop brake pad, shims, shim covers, pad pins and clips.

2. Remove caliper assembly. Refer to [BR-63. "BRAKE CALIPER ASSEMBLY \(2 PISTON TYPE\) : Exploded View"](#).

3. Place a wooden block as shown in the figure, and blow air from union bolt mounting hole to remove pistons and piston boots and retaining rings.

CAUTION:

Never get fingers caught in the pistons.

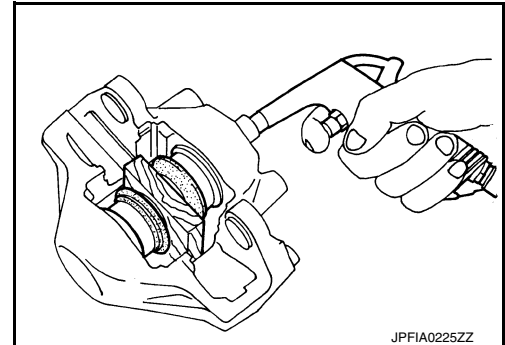

4. Remove piston seal (1) from cylinder body using suitable tool.

CAUTION:

Be careful not to damage a cylinder inner wall.

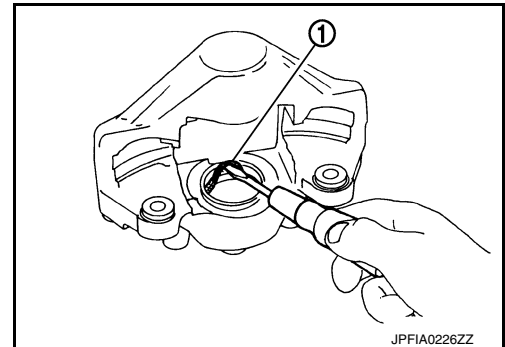

ASSEMBLY

1. Apply brake fluid to piston seals (1), and install them to caliper.

CAUTION:

Never reuse piston seals.

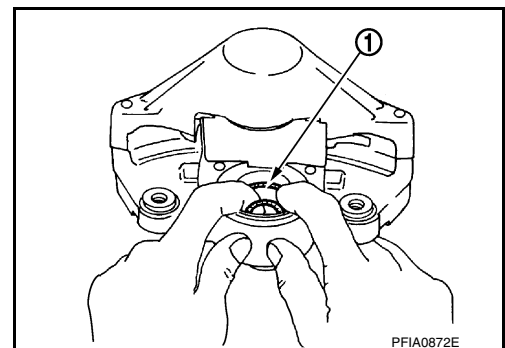

REAR DISC BRAKE

< REMOVAL AND INSTALLATION >

2. Apply rubber grease to piston boots (1). Cover the piston (2) end with piston boots, and then install caliper side lip on piston boot securely into a groove on caliper.

CAUTION:

Never reuse piston boots.

3. Apply brake fluid to piston. Push piston into caliper by hand and push piston boot piston-side lip into the piston groove.

CAUTION:

Press the piston evenly and vary the pressing point to prevent caliper inner wall from being rubbed.

4. Secure piston boot with retaining ring.

CAUTION:

- Make sure that boot is securely engaged in the groove on caliper.
- Never reuse retaining ring.

5. Install the caliper to tighten the caliper mounting bolts to the specified torque. Refer to [BR-63, "BRAKE CALIPER ASSEMBLY \(2 PISTON TYPE\) : Exploded View"](#).

6. Install brake pads. Refer to [BR-56, "BRAKE PAD \(2 PISTON TYPE\) : Exploded View"](#).

CAUTION:

Never drop brake pads, shims, pad pins and clips.

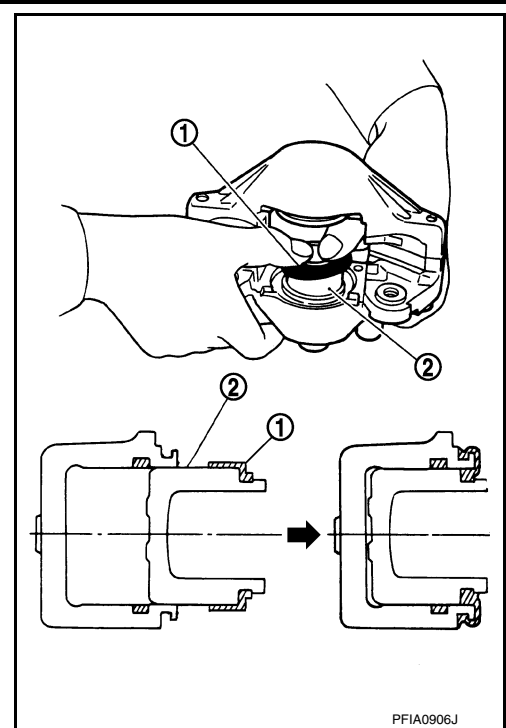

BRAKE CALIPER ASSEMBLY (2 PISTON TYPE) : Inspection

INFOID:000000010585175

INSPECTION AFTER DISASSEMBLY

Caliper

Check the inner wall of the caliper for rust, wear, cracks or damage. Replace the caliper if any abnormal condition is detected.

CAUTION:

Always clean with new brake fluid. Never clean with mineral oil such as gasoline and light oil.

Pistons

Check the surface of the piston for rust, wear, cracks or damage. Replace the piston if any abnormal condition is detected.

CAUTION:

A piston sliding surface is plated. Never polish with sandpaper.

INSPECTION AFTER INSTALLATION

1. Check a drag of rear disc brake. If any drag is found, follow the procedure described below.

2. Remove brake pads.

3. Press the pistons.

CAUTION:

- Never damage the piston boot.
- When replacing a pad with new one, check a brake fluid level in the reservoir tank because brake fluid returns to master cylinder reservoir tank when pressing piston in.

NOTE:

Use a disc brake piston tool to easily press piston.

4. Install brake pads.

5. Depress the brake pedal several times.

6. Check a drag of rear disc brake again. If any drag is found, disassemble the cylinder body.

7. Burnish contact surface between disc rotor and brake pads after refinishing or replacing disc rotor, or if a soft pedal occurs at very low mileage. Refer to [BR-18, "DISC ROTOR : Inspection and Adjustment"](#).

SERVICE DATA AND SPECIFICATIONS (SDS)

< SERVICE DATA AND SPECIFICATIONS (SDS)

SERVICE DATA AND SPECIFICATIONS (SDS)

SERVICE DATA AND SPECIFICATIONS (SDS)

General Specifications

INFOID:0000000010585176

FRONT 2 PISTON AND REAR 1 PISTON TYPE FOR MEXICO

Unit: mm (in)

Front brake	Cylinder bore diameter	45.0 (1.772) × 2
	Pad length × width × thickness	130 × 50.0 × 11.0 (5.12 × 1.969 × 0.433)
	Rotor outer diameter × thickness	320 × 34.0 (12.60 × 1.339)
Rear brake	Cylinder bore diameter	42.86 (1.687)
	Pad length × width × thickness	83.0 × 33.0 × 8.5 (3.268 × 1.299 × 0.335)
	Rotor outer diameter × thickness	308 × 16.0 (12.13 × 0.630)
Master cylinder	Cylinder bore diameter	25.4 (1)
Control valve	Valve type	Electric brake force distribution
Brake booster	Diaphragm diameter	Primary: 230 (9.06)
		Secondary: 205 (8.07)
Recommended brake fluid		Refer to MA-18, "FOR MEXICO : Fluids and Lubricants" .

EXPECT FOR MEXICO

Unit: mm (in)

Front brake	Cylinder bore diameter	45.0 (1.772) × 2
	Pad length × width × thickness	130 × 50.0 × 11.0 (5.12 × 1.969 × 0.433)
	Rotor outer diameter × thickness	320 × 28.0 (12.60 × 1.102)
Rear brake	Cylinder bore diameter	42.86 (1.687)
	Pad length × width × thickness	83.0 × 33.0 × 8.5 (3.268 × 1.299 × 0.335)
	Rotor outer diameter × thickness	308 × 16.0 (12.13 × 0.630)
Master cylinder	Cylinder bore diameter	25.4 (1)
Control valve	Valve type	Electric brake force distribution
Brake booster	Diaphragm diameter	Primary: 230 (9.06)
		Secondary: 205 (8.07)
Recommended brake fluid		Refer to MA-17, "FOR NORTH AMERICA : Fluids and Lubricants" .

FRONT 4 PISTON AND REAR 2 PISTON TYPE

Unit: mm (in)

Front brake	Cylinder bore diameter	41.3 (1.626) × 2 + 44.45 (1.750) × 2
	Pad length × width × thickness	123.2 × 55.0 × 11.0 (4.85 × 2.165 × 0.433)
	Rotor outer diameter × thickness	355 × 32.0 (13.98 × 1.260)
Rear brake	Cylinder bore diameter	41.3 (1.626) × 2
	Pad length × width × thickness	95.8 × 41.5 × 9.5 (3.772 × 1.634 × 0.374)
	Rotor outer diameter × thickness	350 × 20.0 (13.78 × 0.787)
Master cylinder	Cylinder bore diameter	25.4 (1)
Control valve	Valve type	Electric brake force distribution

SERVICE DATA AND SPECIFICATIONS (SDS)

< SERVICE DATA AND SPECIFICATIONS (SDS)

Brake booster	Diaphragm diameter	Primary: 230 (9.06)
		Secondary: 205 (8.07)
Recommended brake fluid		Refer to MA-17. "FOR NORTH AMERICA : Fluids and Lubricants" (except for Mexico), MA-18. "FOR MEXICO : Fluids and Lubricants" (for Mexico).

Brake Pedal

INFOID:000000010585177

Unit: mm (in)

Item		Standard
Brake pedal height	Without DCA	171.5 – 181.5 (6.75 – 7.15)
	With DCA	185.4 – 195.4 (7.30 – 7.69)
Clearance between the stop lamp switch and ASCD brake switch threaded end and the stopper rubber		0.74 – 1.96 (0.0291 – 0.0772)
Brake pedal play		3.0 – 11.0 (0.118 – 0.433)
Depressed brake pedal height [Depressing 490 N (50 kg, 110 lb) while turning the engine ON]	Without DCA	114.0 (4.49) or more
	With DCA	120.8 (4.76) or more

Brake Booster

INFOID:000000010585178

Unit: mm (in)

Item	Standard
Input rod length	126 (4.96)

Front Disc Brake

INFOID:000000010585179

2 PISTON TYPE

FOR MEXICO

Unit: mm (in)

Item		Limit
Brake pad	Wear thickness	2.0 (0.079)
	Wear thickness	32.0 (1.260)
Disc rotor	Thickness variation (measured at 8 positions)*	0.015 (0.0006)
	Runout (with it attached to the vehicle)	0.035 (0.0014)

*To check if rotor imbalance, rotor runout or rotor deformation is occurred.

EXPECT FOR MEXICO

Unit: mm (in)

Item		Limit
Brake pad	Wear thickness	2.0 (0.079)
	Wear thickness	26.0 (1.024)
Disc rotor	Thickness variation (measured at 8 positions)*	0.015 (0.0006)
	Runout (with it attached to the vehicle)	0.035 (0.0014)

*To check if rotor imbalance, rotor runout or rotor deformation is occurred.

4 PISTON TYPE

Unit: mm (in)

Item		Limit
Brake pad	Wear thickness	2.0 (0.079)

SERVICE DATA AND SPECIFICATIONS (SDS)

< SERVICE DATA AND SPECIFICATIONS (SDS)

Item		Limit
Disc rotor	Wear thickness	30.0 (1.181)
	Thickness variation (measured at 8 positions)*	0.015 (0.0006)
	Runout (with it attached to the vehicle)	0.035 (0.0014)

*To check if rotor imbalance, rotor runout or rotor deformation is occurred.

Rear Disc Brake

INFOID:0000000010585180

1 PISTON TYPE

Unit: mm (in)

Item		Limit
Brake pad	Wear thickness	2.0 (0.079)
Disc rotor	Wear thickness	14.0 (0.551)
	Thickness variation (measured at 8 positions)*	0.015 (0.0006)
	Runout (with it attached to the vehicle)	0.055 (0.0022)

*To check if rotor imbalance, rotor runout or rotor deformation is occurred.

2 PISTON TYPE

Unit: mm (in)

Item		Limit
Brake pad	Wear thickness	2.0 (0.079)
Disc rotor	Wear thickness	18.0 (0.709)
	Thickness variation (measured at 8 positions)*	0.015 (0.0006)
	Runout (with it attached to the vehicle)	0.055 (0.0022)

*To check if rotor imbalance, rotor runout or rotor deformation is occurred.