

MWI

SECTION

METER, WARNING LAMP & INDICATOR

A
B
C
D
E
F
G
H
I
J
K
L
M
N
O
P

CONTENTS

BASIC INSPECTION	4	ODO/TRIP METER	20
DIAGNOSIS AND REPAIR WORKFLOW	4	ODO/TRIP METER : System Diagram	20
Work flow	4	ODO/TRIP METER : System Description	20
SYSTEM DESCRIPTION	6	ODO/TRIP METER : Component Parts Location	21
METER SYSTEM	6	ODO/TRIP METER : Component Description	22
METER SYSTEM	6	SHIFT POSITION INDICATOR	22
METER SYSTEM : System Diagram	6	SHIFT POSITION INDICATOR : System Diagram	22
METER SYSTEM : System Description	6	SHIFT POSITION INDICATOR : System Description	22
METER SYSTEM : Component Parts Location	10	SHIFT POSITION INDICATOR : Component Parts Location	24
METER SYSTEM : Component Description	11	SHIFT POSITION INDICATOR : Component Description	25
SPEEDOMETER	12	WARNING LAMPS/INDICATOR LAMPS	25
SPEEDOMETER : System Diagram	12	WARNING LAMPS/INDICATOR LAMPS : System Diagram	25
SPEEDOMETER : System Description	12	WARNING LAMPS/INDICATOR LAMPS : System Description	25
SPEEDOMETER : Component Parts Location	13	WARNING LAMPS/INDICATOR LAMPS : Component Parts Location	26
SPEEDOMETER : Component Description	14	WARNING LAMPS/INDICATOR LAMPS : Component Description	27
TACHOMETER	14	METER ILLUMINATION CONTROL	27
TACHOMETER : System Diagram	14	METER ILLUMINATION CONTROL : System Diagram	27
TACHOMETER : System Description	14	METER ILLUMINATION CONTROL : System Description	27
TACHOMETER : Component Parts Location	15	METER ILLUMINATION CONTROL : Component Parts Location	29
TACHOMETER : Component Description	16	METER ILLUMINATION CONTROL : Component Description	30
ENGINE COOLANT TEMPERATURE GAUGE	16	METER EFFECT FUNCTION	30
ENGINE COOLANT TEMPERATURE GAUGE : System Diagram	16	METER EFFECT FUNCTION : System Diagram	30
ENGINE COOLANT TEMPERATURE GAUGE : System Description	16	METER EFFECT FUNCTION : System Description	30
ENGINE COOLANT TEMPERATURE GAUGE : Component Parts Location	17	METER EFFECT FUNCTION : Component Parts Location	32
ENGINE COOLANT TEMPERATURE GAUGE : Component Description	18		
FUEL GAUGE	18		
FUEL GAUGE : System Diagram	18		
FUEL GAUGE : System Description	18		
FUEL GAUGE : Component Parts Location	19		
FUEL GAUGE : Component Description	20		

MWI

METER EFFECT FUNCTION : Component Description	33	POWER SUPPLY AND GROUND CIRCUIT	58
INFORMATION DISPLAY	33	COMBINATION METER	58
INFORMATION DISPLAY : System Diagram	33	COMBINATION METER : Diagnosis Procedure	58
INFORMATION DISPLAY : System Description ...	33	UNIFIED METER AND A/C AMP.	58
INFORMATION DISPLAY : Component Parts Location	37	UNIFIED METER AND A/C AMP. : Diagnosis Procedure	58
INFORMATION DISPLAY : Component Description	38	IPDM E/R (INTELLIGENT POWER DISTRIBUTION MODULE ENGINE ROOM)	59
COMPASS	39	IPDM E/R (INTELLIGENT POWER DISTRIBUTION MODULE ENGINE ROOM) : Diagnosis Procedure	59
Description	39	FUEL LEVEL SENSOR SIGNAL CIRCUIT	61
Component Parts Location	41	Description	61
Special Repair Requirement	41	Component Function Check	61
CLOCK	42	Diagnosis Procedure	62
Component Parts Location	42	Component Inspection	63
DIAGNOSIS SYSTEM (METER)	43	METER CONTROL SWITCH SIGNAL CIRCUIT	65
Diagnosis Description	43	Description	65
DIAGNOSIS SYSTEM (UNIFIED METER AND A/C AMP.)	45	Diagnosis Procedure	65
CONSULT Function (METER/M&A)	45	Component Inspection	66
DTC/CIRCUIT DIAGNOSIS	49	TRIP A/B RESET SWITCH SIGNAL CIRCUIT..	67
U1000 CAN COMM CIRCUIT	49	Description	67
Description	49	Diagnosis Procedure	67
DTC Logic	49	Component Inspection	67
Diagnosis Procedure	49	OIL PRESSURE SWITCH SIGNAL CIRCUIT ...	69
U1010 CONTROL UNIT (CAN)	50	Description	69
Description	50	Component Function Check	69
DTC Logic	50	Diagnosis Procedure	69
Diagnosis Procedure	50	Component Inspection	69
B2201 COMMUNICATION ERROR 1	51	PARKING BRAKE SWITCH SIGNAL CIRCUIT	70
Description	51	Description	70
DTC Logic	51	Diagnosis Procedure	70
Diagnosis Procedure	51	Component Inspection	70
B2202 COMMUNICATION ERROR 2	53	WASHER LEVEL SWITCH SIGNAL CIRCUIT..	72
Description	53	Description	72
DTC Logic	53	Diagnosis Procedure	72
Diagnosis Procedure	53	Component Inspection	72
B2205 VEHICLE SPEED	55	COMPASS	73
Description	55	Wiring Diagram - COMPASS -	73
DTC Logic	55	CLOCK	76
Diagnosis Procedure	55	Wiring Diagram - CLOCK -	76
B2267 ENGINE SPEED	56	ECU DIAGNOSIS INFORMATION	78
Description	56	COMBINATION METER	78
DTC Logic	56	Reference Value	78
Diagnosis Procedure	56	Wiring Diagram - METER -	81
B2268 WATER TEMP	57	Fail-Safe	94
Description	57	DTC Index	95
DTC Logic	57		
Diagnosis Procedure	57		

UNIFIED METER AND A/C AMP.	96	Description	138	
Reference Value	96	Diagnosis Procedure	138	A
Wiring Diagram - METER -	103			
Fail-Safe	116	THE AMBIENT TEMPERATURE DISPLAY IS		
DTC Index	117	INCORRECT	139	B
		Description	139	
IPDM E/R (INTELLIGENT POWER DISTRI-		Diagnosis Procedure	139	
BUTION MODULE ENGINE ROOM)	118			
Reference Value	118	NORMAL OPERATING CONDITION	140	C
Wiring Diagram - IPDM E/R -	125			
Fail-safe	128	COMPASS	140	
DTC Index	130	COMPASS : Description	140	D
SYMPTOM DIAGNOSIS	131	INFORMATION DISPLAY	140	
		INFORMATION DISPLAY : Description	140	
THE FUEL GAUGE POINTER DOES NOT				
MOVE	131	PRECAUTION	141	E
Description	131			
Diagnosis Procedure	131	PRECAUTIONS	141	
		Precaution for Supplemental Restraint System		F
THE METER CONTROL SWITCH IS INOPER-		(SRS) "AIR BAG" and "SEAT BELT PRE-TEN-		
ACTIVE	132	SIONER"	141	G
Description	132	Precautions for Removing Battery Terminal	141	
Diagnosis Procedure	132			
		PREPARATION	142	
THE TRIP A/B RESET SWITCH IS INOPERA-				
TIVE	133	PREPARATION	142	H
Description	133	Commercial Service Tools	142	
Diagnosis Procedure	133			
		REMOVAL AND INSTALLATION	143	
THE OIL PRESSURE WARNING LAMP				
DOES NOT TURN ON	134	COMBINATION METER	143	
Description	134	Exploded View	143	I
Diagnosis Procedure	134	Removal and Installation	143	J
		Disassembly and Assembly	143	
THE OIL PRESSURE WARNING LAMP				
DOES NOT TURN OFF	135	UNIFIED METER AND A/C AMP.	144	K
Description	135	Exploded View	144	
Diagnosis Procedure	135	Removal and Installation	144	
THE PARKING BRAKE RELEASE WARNING		METER CONTROL SWITCH	145	L
CONTINUES DISPLAYING, OR DOES NOT		Exploded View	145	
DISPLAY	136	Removal and Installation	145	
Description	136			
Diagnosis Procedure	136	TRIP A/B RESET SWITCH	146	M
		Exploded View	146	
		Removal and Installation	146	
THE LOW WASHER FLUID WARNING CON-				
TINUES DISPLAYING, or DOES NOT DIS-		COMPASS	147	
PLAY	137	Exploded View	147	O
Description	137	Removal and Installation	147	
Diagnosis Procedure	137			
		CLOCK	148	
THE DOOR OPEN WARNING CONTINUES		Exploded View	148	P
DISPLAYING, OR DOES NOT DISPLAY	138	Removal and Installation	148	

MWI

DIAGNOSIS AND REPAIR WORKFLOW

< BASIC INSPECTION >

BASIC INSPECTION

DIAGNOSIS AND REPAIR WORKFLOW

Work flow

INFOID:000000010576984

OVERALL SEQUENCE

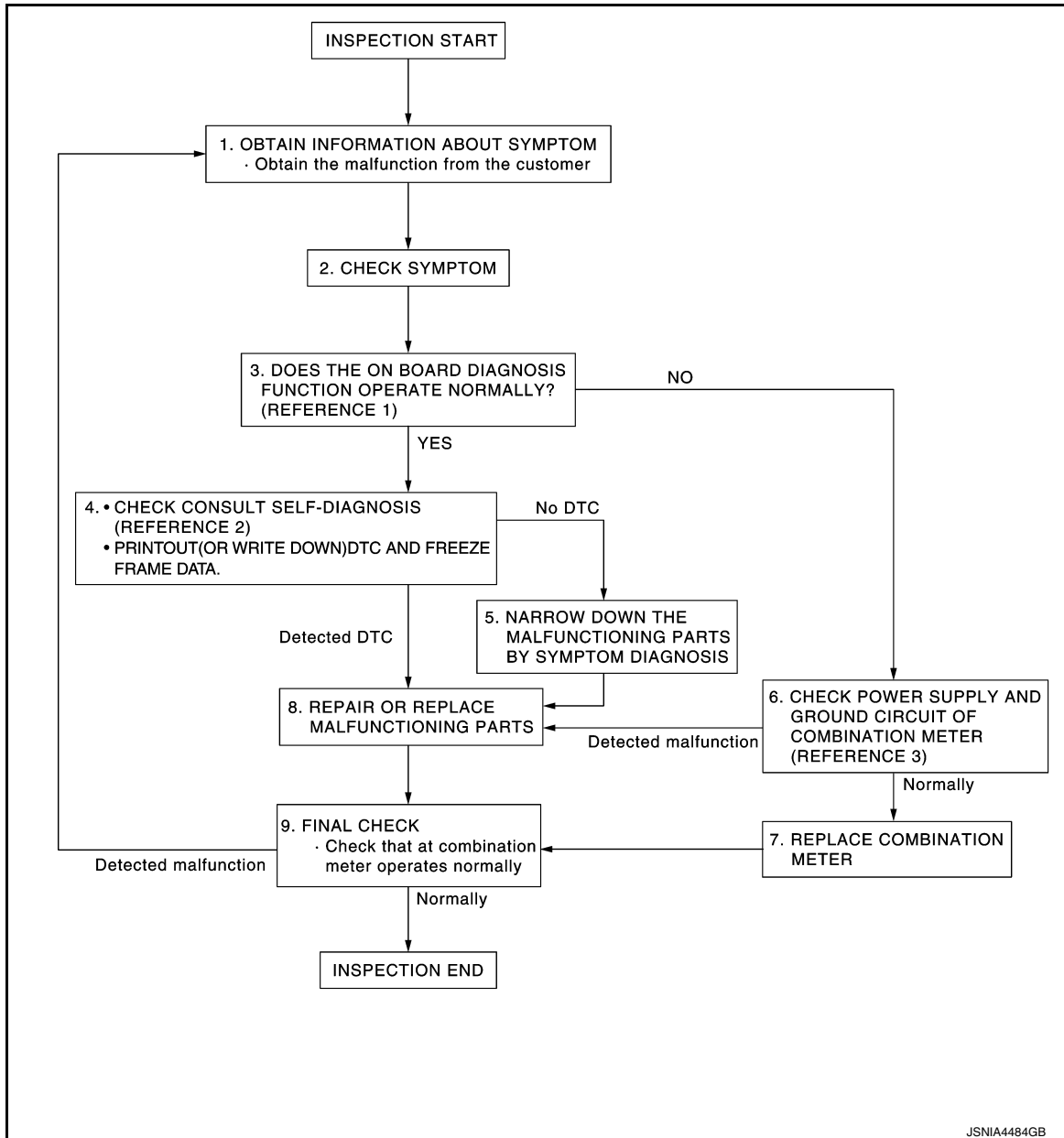

- Reference 1...[MWI-43, "Diagnosis Description"](#).
- Reference 2...[MWI-117, "DTC Index"](#).
- Reference 3...[MWI-58, "COMBINATION METER : Diagnosis Procedure"](#).

DETAILED FLOW

1.OBTAIN INFORMATION ABOUT SYMPTOM

Interview the customer to obtain as much information as possible about the conditions and environment under which the malfunction occurred.

>> GO TO 2.

2.CHECK SYMPTOM

DIAGNOSIS AND REPAIR WORKFLOW

< BASIC INSPECTION >

- Check the symptom based on the information obtained from the customer.
- Check that any other malfunctions are present.

>> GO TO 3.

3. CHECK ON BOARD DIAGNOSIS OPERATION

Check that the on board diagnosis function operates. Refer to [MWI-43, "Diagnosis Description"](#).

Does the on board diagnosis function operate normally?

YES >> GO TO 4.

NO >> GO TO 6.

4. CHECK CONSULT SELF-DIAGNOSIS RESULTS

1. Connect CONSULT and perform self-diagnosis. Refer to [MWI-117, "DTC Index"](#).
2. When DTC is detected, follow the instructions below:
 - Record DTC and Freeze Frame Data.

Are self-diagnosis results normal?

YES >> GO TO 5.

NO >> GO TO 8.

5. NARROW DOWN THE MALFUNCTIONING PARTS BY SYMPTOM DIAGNOSIS

Perform symptom diagnosis and narrow down the malfunctioning parts.

>> GO TO 8.

6. CHECK COMBINATION METER POWER SUPPLY AND GROUND CIRCUITS

Inspect combination meter power supply and ground circuits. Refer to [MWI-58, "COMBINATION METER : Diagnosis Procedure"](#).

Is the inspection result normal?

YES >> GO TO 7.

NO >> GO TO 8.

7. REPLACE COMBINATION METER

Replace combination meter.

>> GO TO 9.

8. REPAIR OR REPLACE MALFUNCTIONING PARTS

Repair or replace the malfunctioning parts.

NOTE:

If DTC is displayed, erase DTC after repair or replace malfunctioning parts.

>> GO TO 9.

9. FINAL CHECK

Check that the combination meter operates normally.

Do they operate normally?

YES >> INSPECTION END

NO >> GO TO 1.

A
B
C
D
E
F
G
H
I
J
K
L
M
O
P

MWI

METER SYSTEM

< SYSTEM DESCRIPTION >

SYSTEM DESCRIPTION

METER SYSTEM

METER SYSTEM

METER SYSTEM : System Diagram

INFOID:000000010576985

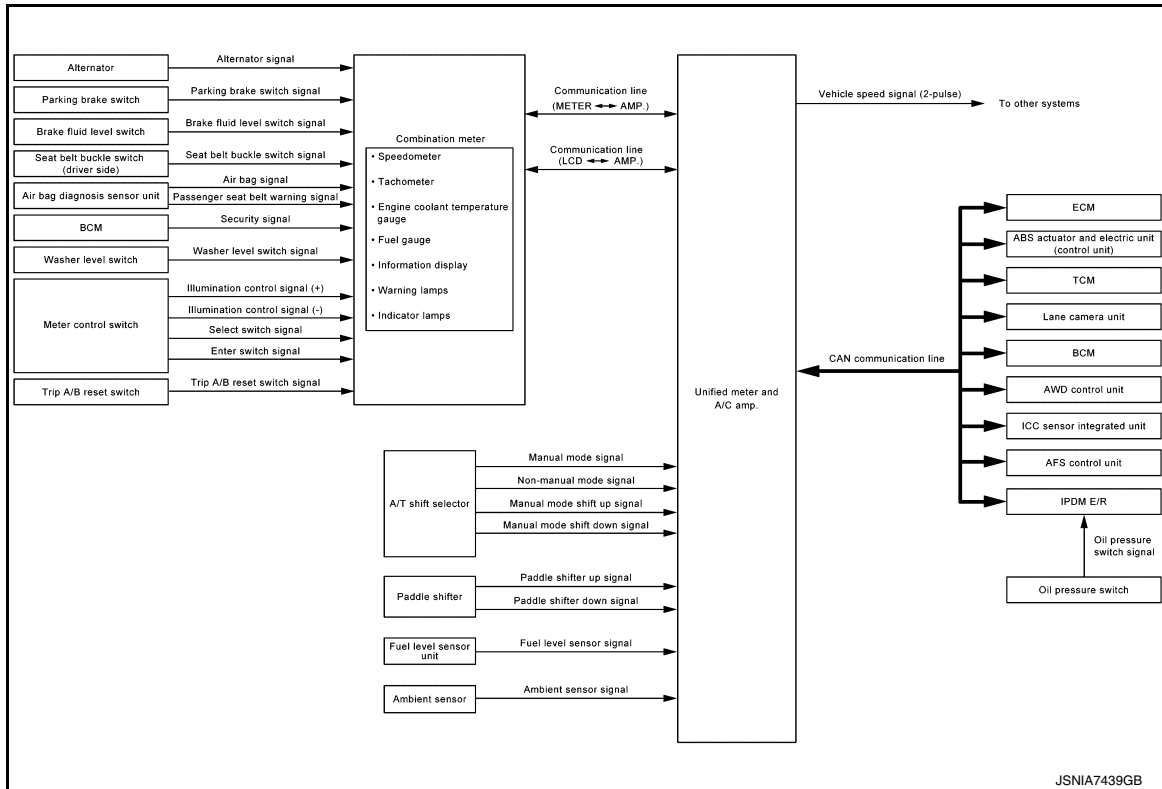

METER SYSTEM : System Description

INFOID:000000010576986

COMBINATION METER

- The combination meter retrieves the information required for controlling the operations of the meters, indicator lamps/warning lamps and information display from the communication signals from the unified meter and A/C amp. and the signals from various switches and sensors.
- The combination meter incorporates a trip computer that displays warnings and messages on the information display according to the information received from various units.
- The combination meter incorporates a buzzer function that sounds an audible alarm with the integrated buzzer device. Refer to [WCS-5. "WARNING CHIME SYSTEM : System Description"](#) for further details.
- The combination meter integrates the meter circuit check function and the segment check function that checks the information display operation.

UNIFIED METER AND A/C AMP.

- Receives information required by the combination meter from various units via CAN communication line and transmits it to the combination meter with communication line.
- The unified meter and A/C amp. incorporates a power saving control function that reduces the power consumption according to the vehicle status. Refer to [BCS-17. "System Description"](#) for details.
- The unified meter and A/C amp. incorporates a diagnosis function that allows the technician to perform diagnoses with CONSULT.

METER SYSTEM

< SYSTEM DESCRIPTION >

Between unified meter and A/C amp. and combination meter.			
Unit	Communication line	Input from combination meter	Output to combination meter
Unified meter and A/C amp.	Communication line (METER <-> AMP.)	<ul style="list-style-type: none"> • Parking brake switch signal • Washer level switch signal • Meter day/night condition signal • Illumination control switch signal • Refuel status signal • Low fuel warning lamp signal • Odo data signal 	<ul style="list-style-type: none"> • Vehicle speed signal • Turn indicator signal • High beam request signal • Position light request signal • Front fog light request signal • Engine speed signal • Fuel level sensor signal • Engine coolant temperature signal • A/T CHECK indicator signal • Oil pressure switch signal • Door switch signal • Buzzer output signal • Key warning lamp signal • AFS OFF indicator lamp signal • TPMS malfunction warning lamp signal • AWD warning lamp signal • VDC OFF indicator lamp signal • VDC warning lamp signal • IBA OFF indicator lamp signal • ABS warning lamp signal • Brake warning lamp signal • Malfunction indicator lamp signal • Master warning signal • ICC warning lamp signal • Lane departure warning lamp signal • LDP ON indicator lamp signal • Meter effect signal • Meter ring illumination request signal
	Communication line (LCD <-> AMP.)	<ul style="list-style-type: none"> • Average fuel consumption reset signal • Travel time reset signal • Possible driving distance reset signal • Average vehicle speed reset signal • Select switch signal • Enter switch signal • Trip A/B reset switch signal • Ambient air temperature display signal 	<ul style="list-style-type: none"> • Shift position signal • Meter display signal • Door switch signal • Fuel level sensor signal • Parking brake switch signal • Washer level switch signal • Charge warning signal • Instantaneous fuel consumption display signal • Ambient air temperature display signal • Average fuel consumption display signal • Average vehicle speed display signal • Possible driving distance display signal • Engine speed signal • Vehicle speed signal • Meter effect signal • Low tire pressure warning lamp signal • Fuel filler cap warning display signal

IPDM E/R

- IPDM E/R reads the ON/OFF signals of the oil pressure switch and transmits the oil pressure switch signal to the unified meter and A/C amp. via BCM with the CAN communication line.
- IPDM E/R is equipped with the diagnosis function. It can perform the operation check of oil pressure warning lamp with the auto active test and the diagnosis with CONSULT.

METER CONTROL FUNCTION LIST

METER SYSTEM

< SYSTEM DESCRIPTION >

X: Applicable

System		Description	Signal source	Via unified meter and A/C amp.
Meter/gauge	Speedometer	Receives vehicle speed signal and indicates vehicle speed.	ABS actuator and electric unit (control unit)	X
	Tachometer	Receives engine speed signal and indicates engine speed.	ECM	X
	Fuel gauge	Receives fuel level sensor signal and indicates fuel level.	Fuel level sensor unit	X
	Engine coolant temperature gauge	Receives engine coolant temperature signal and indicates coolant temperature.	ECM	X
Warning lamp/indicator lamp	Oil pressure warning lamp	Receives oil pressure warning lamp signal and illuminates warning lamp.	IPDM E/R	X
	Master warning	Illuminates according to warning output on information display.	—	X
Information display	Parking brake release warning	Receives parking brake switch signal and vehicle speed signal and displays warnings.	Parking brake switch	
			ABS actuator and electric unit (control unit)	X
	Low fuel warning	Receives fuel gauge signal and displays warning if fuel level decreases to 13.7 ℓ (3 - 5/8 US gal, 3 Imp gal) or less.	Fuel level sensor unit	X
	Low washer fluid warning	Receives washer level switch signal and displays warning.	Washer level switch	
	Low outside temperature warning	Monitors ambient sensor signal and displays warning if ambient temperature decreases to 3°C (37°F) or less. (If enabled)	Ambient sensor	X
	Door open warning	Receives door switch signals and displays warning.	BCM	X
	Low tire pressure warning	Receives low tire pressure warning lamp signal and displays warning.	BCM	X
	Fuel filler cap warning	Receives fuel filler cap warning display signals and displays warning.	ECM	X
	Instantaneous fuel consumption	Calculates instantaneous fuel consumption based on received vehicle speed signals and fuel consumption monitor signal and displays it.	ECM	X
			ABS actuator and electric unit (control unit)	X
	Average fuel consumption	Calculates average fuel consumption in a reset-to-reset interval based on received vehicle speed signals and fuel consumption monitor signal and displays it.	ECM	X
			ABS actuator and electric unit (control unit)	X
	Average vehicle speed	Calculates average vehicle speed in a reset-to-reset interval based on received vehicle speed signals and displays it.	ABS actuator and electric unit (control unit)	X
	Travel time	Displays accumulated key switch ON time from reset to reset.	—	X
	Travel distance	Calculates accumulated travel distance in a reset-to-reset interval based on received vehicle speed signals and displays it.	ABS actuator and electric unit (control unit)	X
Possible driving distance	Calculates possible driving distance based on received fuel consumption monitor signal, vehicle speed signals and fuel level sensor signal and displays it.	ECM	X	
		ABS actuator and electric unit (control unit)	X	
		Fuel level sensor unit	X	
Ambient air temperature	Corrects ambient air temperature value based on received ambient sensor signals and displays it.	Ambient sensor	X	

METER SYSTEM

< SYSTEM DESCRIPTION >

ARRANGEMENT OF COMBINATION METER

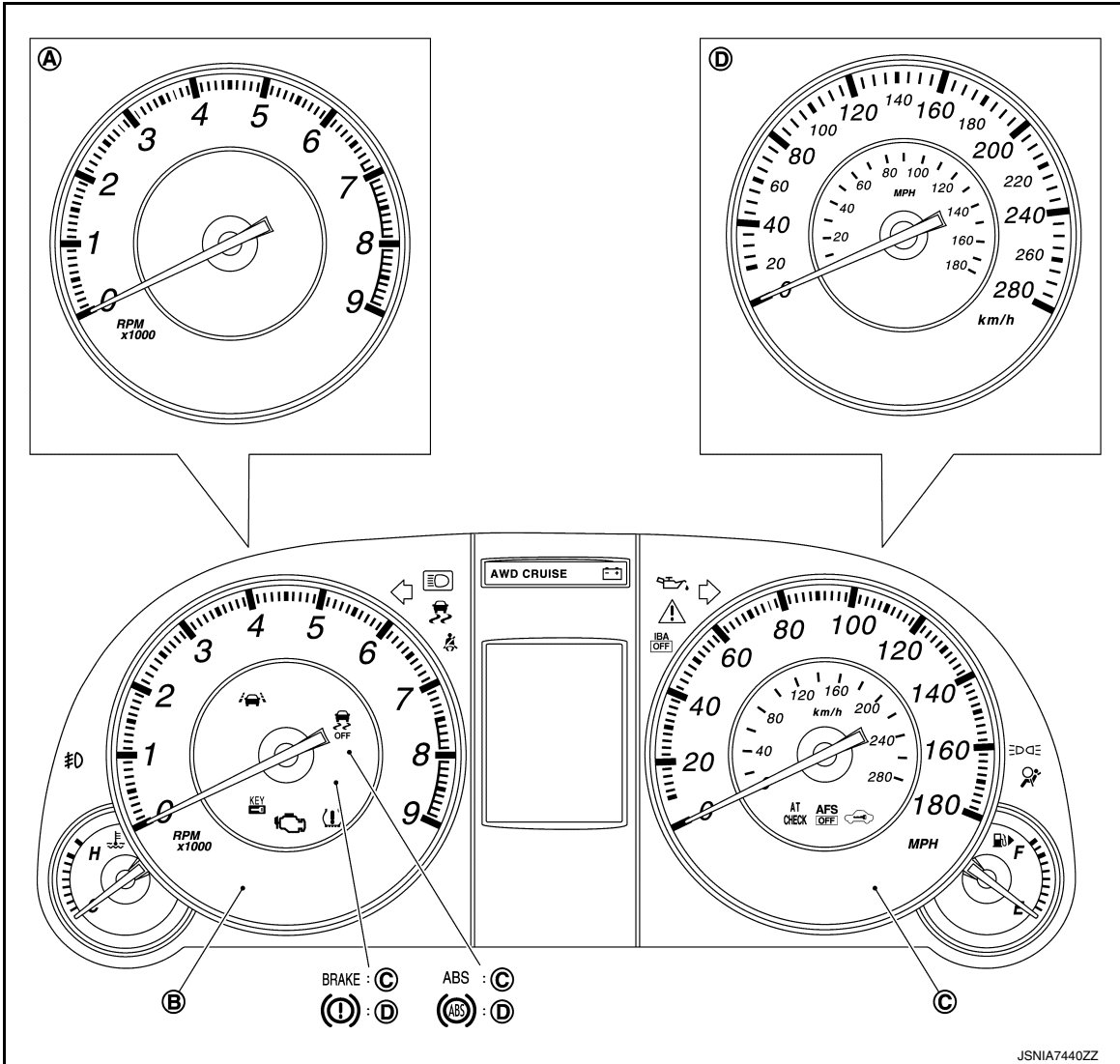

A. VK50VE engine models

B. VQ37VHR engine models

C. For U.S.A.

D. Except for U.S.A.

A
B
C
D
E
F
G
H
I
J
K
L
M
N
O
P

MWI

METER SYSTEM

< SYSTEM DESCRIPTION >

METER SYSTEM : Component Parts Location

INFOID:000000010576987

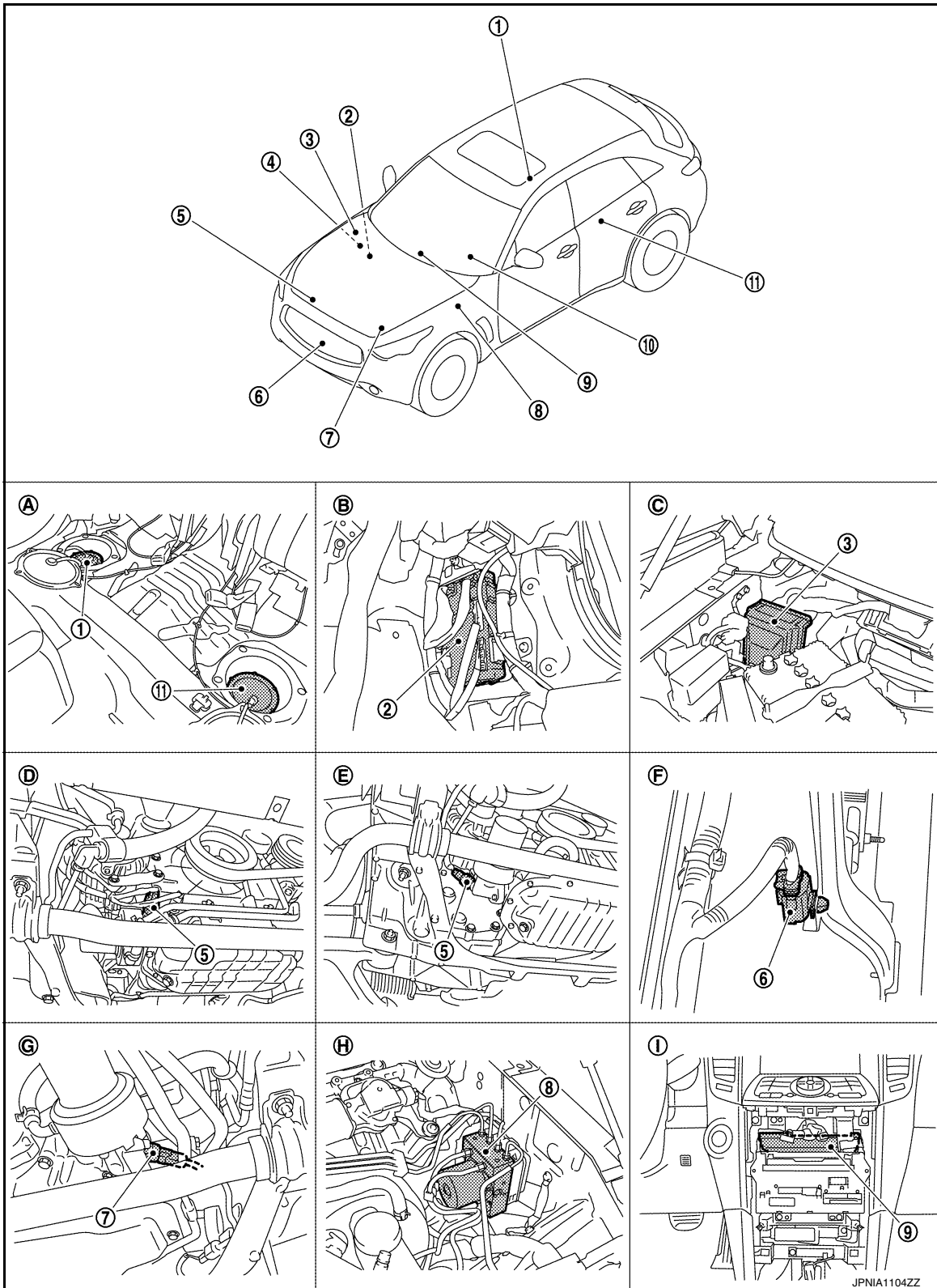

METER SYSTEM

< SYSTEM DESCRIPTION >

- | | | | |
|--|--|-------------------------------|---|
| 1. Fuel level sensor unit and fuel pump (main) | 2. BCM | 3. IPDM E/R | A |
| 4. ECM : EC-51, "Component Parts Location" (VQ37VHR for USA and Canada)
ECM : EC-654, "Component Parts Location" (VQ37VHR for Mexico)
ECM : EC-1149, "Component Parts Location" (VK50VE engine models) | 5. Oil pressure switch (VQ37VHR engine models) | 6. Ambient sensor | B |
| 7. Oil pressure switch (VK50VE engine models) | 8. ABS actuator and electric unit (control unit) | 9. Unified meter and A/C amp. | C |
| 10. Combination meter | 11. Fuel level sensor unit (sub) | | D |
| A. Rear seat (bottom) | B. Dash side finisher (passenger side) | C. Hoodledge cover (RH) | |
| D. 2WD [oil pan (upper) RH side] | E. AWD [oil filter bracket part (VQ37VHR engine models)] | F. Condenser (front) | E |
| G. AWD [oil filter bracket part (VK50VE engine models)] | H. Hoodledge cover (LH) | I. Behind cluster lid C | F |

METER SYSTEM : Component Description

INFOID:0000000010576988

Unit	Description
Combination meter	Controls the following with the signals from the unified meter and A/C amp, switches and sensors. <ul style="list-style-type: none"> Speedometer Engine coolant temperature gauge Warning lamps Information display Tachometer Fuel gauge Indicator lamps
Unified meter and A/C amp.	<ul style="list-style-type: none"> The combination meter receives the necessary information from various units via CAN communication line and transmits them to the unified meter and A/C amp. with the communication line that connects both of them. Transmits the fuel gauge signal from the fuel gauge unit with the communication line that connects the unified meter and A/C amp. and the combination meter. Reads the signals from the A/T shift selector and paddle shifter transmits them to TCM with CAN communication line.
IPDM E/R	IPDM E/R reads the ON/OFF signals of the oil pressure switch and transmits the oil pressure switch signal to the unified meter and A/C amp. via BCM with CAN communication line.
Fuel level sensor unit	Refer to MWI-61, "Description" .
Oil pressure switch	Refer to MWI-69, "Description" .
ECM	Transmits the following signals to the unified meter and A/C amp. with CAN communication line. <ul style="list-style-type: none"> Engine speed signal Fuel consumption monitor signal Engine coolant temperature signal Fuel filler cap warning display signal
ABS actuator and electric unit (control unit)	Transmits the vehicle speed signal to the unified meter and A/C amp. with CAN communication line.
BCM	<ul style="list-style-type: none"> Transmits signals provided by various units to the unified meter and A/C amp. with CAN communication line. Transmits the security signal and low tire pressure warning lamp signal to the combination meter.
A/T shift selector	Transmits the following signals to the unified meter and A/C amp. <ul style="list-style-type: none"> Manual mode signal Manual mode shift up signal Non-manual mode signal Manual mode shift down signal
Paddle shifter	Transmits the paddle shifter up signal and paddle shifter down signal to the unified meter and A/C amp.
TCM	Transmits shift position signal to the unified meter and A/C amp.
Meter control switch	Refer to MWI-65, "Description" .
Trip A/B reset switch	Refer to MWI-67, "Description" .

METER SYSTEM

< SYSTEM DESCRIPTION >

Unit	Description
Washer level switch	Transmits the washer level signal to the combination meter.
Parking brake switch	Refer to MWI-70. "Description" .

SPEEDOMETER

SPEEDOMETER : System Diagram

INFOID:000000010576989

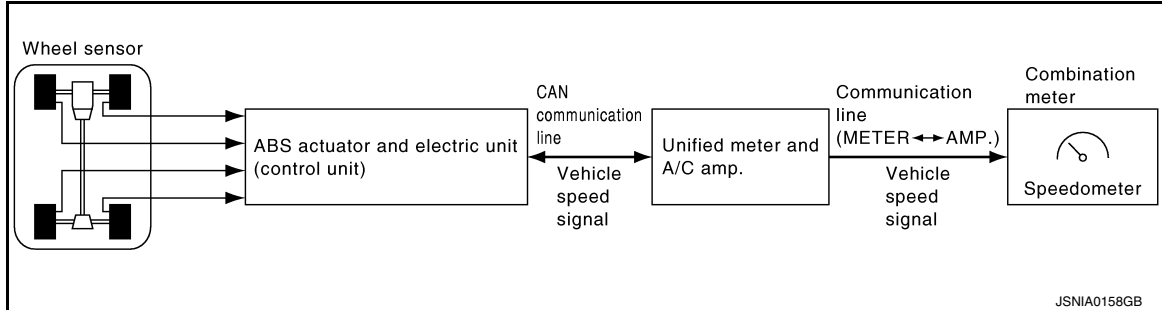

SPEEDOMETER : System Description

INFOID:000000010576990

- The ABS actuator and electric unit (control unit) converts the pulse signal provided by the wheel sensor to a vehicle speed signal and transmits it to the unified meter and A/C amp. with CAN communication line.
- The unified meter and A/C amp. receives the vehicle speed signal from the ABS actuator and electric unit (control unit) with CAN communication line and transmits it to the combination meter by means of communication line.
- The combination meter indicates the vehicle speed according to the vehicle speed signal received from the unified meter and A/C amp. by means of communication line.

METER SYSTEM

< SYSTEM DESCRIPTION >

SPEEDOMETER : Component Parts Location

INFOID:000000010576991

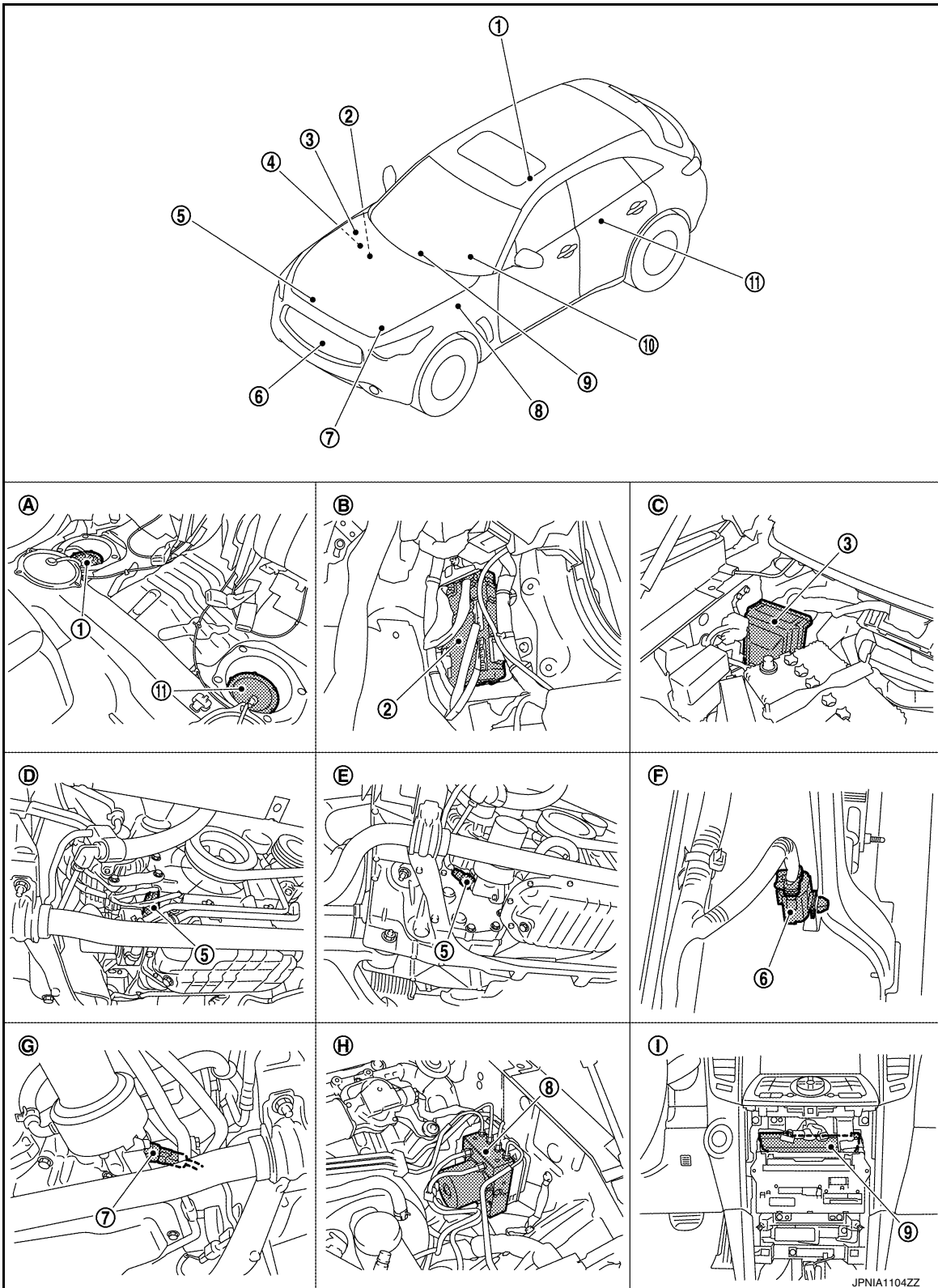

A
B
C
D
E
F
G
H
I
J
K
L
M
MWI
O
P

METER SYSTEM

< SYSTEM DESCRIPTION >

- | | | |
|--|--|-------------------------------|
| 1. Fuel level sensor unit and fuel pump (main) | 2. BCM | 3. IPDM E/R |
| 4. ECM : EC-51, "Component Parts Location" (VQ37VHR for USA and Canada)
ECM : EC-654, "Component Parts Location" (VQ37VHR for Mexico)
ECM : EC-1149, "Component Parts Location" (VK50VE engine models) | 5. Oil pressure switch (VQ37VHR engine models) | 6. Ambient sensor |
| 7. Oil pressure switch (VK50VE engine models) | 8. ABS actuator and electric unit (control unit) | 9. Unified meter and A/C amp. |
| 10. Combination meter | 11. Fuel level sensor unit (sub) | |
| A. Rear seat (bottom) | B. Dash side finisher (passenger side) | C. Hoodledge cover (RH) |
| D. 2WD [oil pan (upper) RH side] | E. AWD [oil filter bracket part (VQ37VHR engine models)] | F. Condenser (front) |
| G. AWD [oil filter bracket part (VK50VE engine models)] | H. Hoodledge cover (LH) | I. Behind cluster lid C |

SPEEDOMETER : Component Description

INFOID:000000010576992

Unit	Description
Combination meter	Indicates the vehicle speed according to the vehicle speed signal received from the unified meter and A/C amp. by means of communication line.
Unified meter and A/C amp.	Transmits the vehicle speed signal received from ABS actuator and electric unit (control unit) with CAN communication line to the combination meter by means of communication line.
ABS actuator and electric unit (control unit)	Transmits the vehicle speed signal to the unified meter and A/C amp. with CAN communication line.

TACHOMETER

TACHOMETER : System Diagram

INFOID:000000010576993

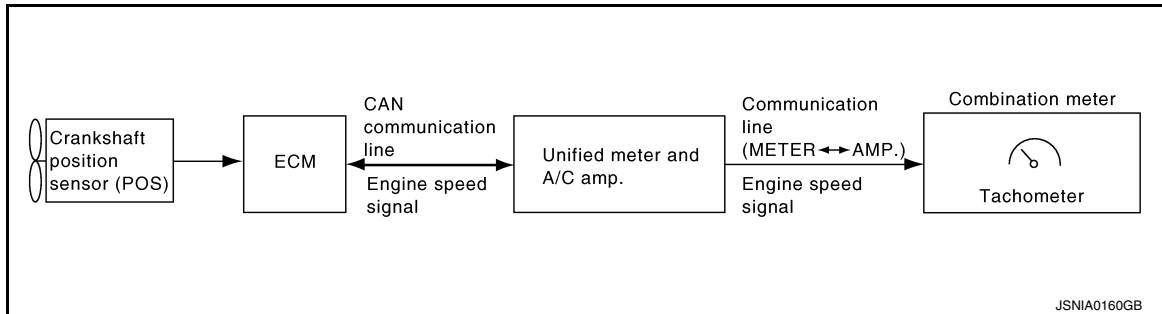

TACHOMETER : System Description

INFOID:000000010576994

- ECM converts the pulse signal provided by the crankshaft position sensor to an engine speed signal and transmits it to the unified meter and A/C amp. with CAN communication line.
- The unified meter and A/C amp. receives the engine speed signal from ECM with CAN communication line and transmits it to the combination meter by means of communication line.
- Combination meter converses engine speed signal to the angle signal, and commands to tachometer.

METER SYSTEM

< SYSTEM DESCRIPTION >

TACHOMETER : Component Parts Location

INFOID:0000000110576995

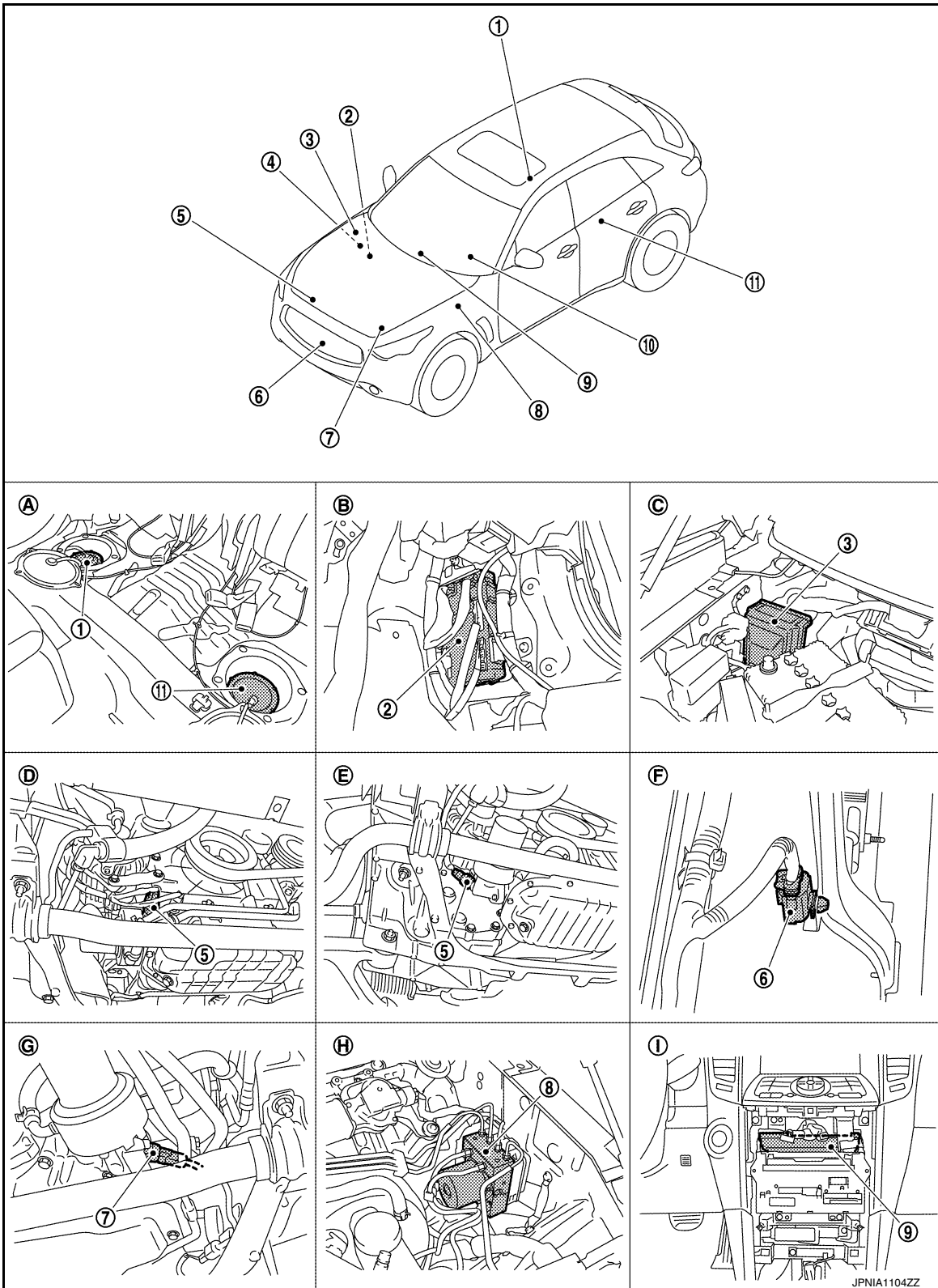

A
B
C
D
E
F
G
H
I
J
K
L
M
N
O
P

MWI

METER SYSTEM

< SYSTEM DESCRIPTION >

- | | | |
|--|--|-------------------------------|
| 1. Fuel level sensor unit and fuel pump (main) | 2. BCM | 3. IPDM E/R |
| 4. ECM : EC-51, "Component Parts Location" (VQ37VHR for USA and Canada)
ECM : EC-654, "Component Parts Location" (VQ37VHR for Mexico)
ECM : EC-1149, "Component Parts Location" (VK50VE engine models) | 5. Oil pressure switch (VQ37VHR engine models) | 6. Ambient sensor |
| 7. Oil pressure switch (VK50VE engine models) | 8. ABS actuator and electric unit (control unit) | 9. Unified meter and A/C amp. |
| 10. Combination meter | 11. Fuel level sensor unit (sub) | |
| A. Rear seat (bottom) | B. Dash side finisher (passenger side) | C. Hoodledge cover (RH) |
| D. 2WD [oil pan (upper) RH side] | E. AWD [oil filter bracket part (VQ37VHR engine models)] | F. Condenser (front) |
| G. AWD [oil filter bracket part (VK50VE engine models)] | H. Hoodledge cover (LH) | I. Behind cluster lid C |

TACHOMETER : Component Description

INFOID:000000010576996

Unit	Description
Combination meter	Indicates the engine speed according to the engine speed signal received from the unified meter and A/C amp. by means of communication line.
Unified meter and A/C amp.	Transmits the engine speed signal received from ECM with CAN communication line to the combination meter by means of communication line.
ECM	Transmits the engine speed signal to the unified meter and A/C amp. with CAN communication line.

ENGINE COOLANT TEMPERATURE GAUGE

ENGINE COOLANT TEMPERATURE GAUGE : System Diagram

INFOID:000000010576997

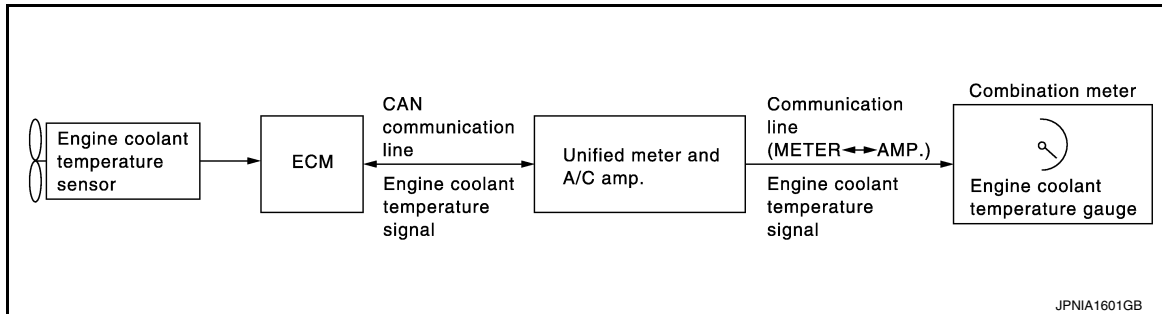

ENGINE COOLANT TEMPERATURE GAUGE : System Description

INFOID:000000010576998

- ECM converses a signal from engine coolant temperature sensor to engine coolant temperature signal, and transmits to unified meter and A/C amp. with CAN communication line.
- Unified meter and A/C amp. transmits engine coolant temperature signal to combination meter with communication line.
- Combination meter converses engine coolant temperature signal to the angle signal, and commands to engine coolant temperature gauge.

METER SYSTEM

< SYSTEM DESCRIPTION >

ENGINE COOLANT TEMPERATURE GAUGE : Component Parts Location

INFOID:000000010576999

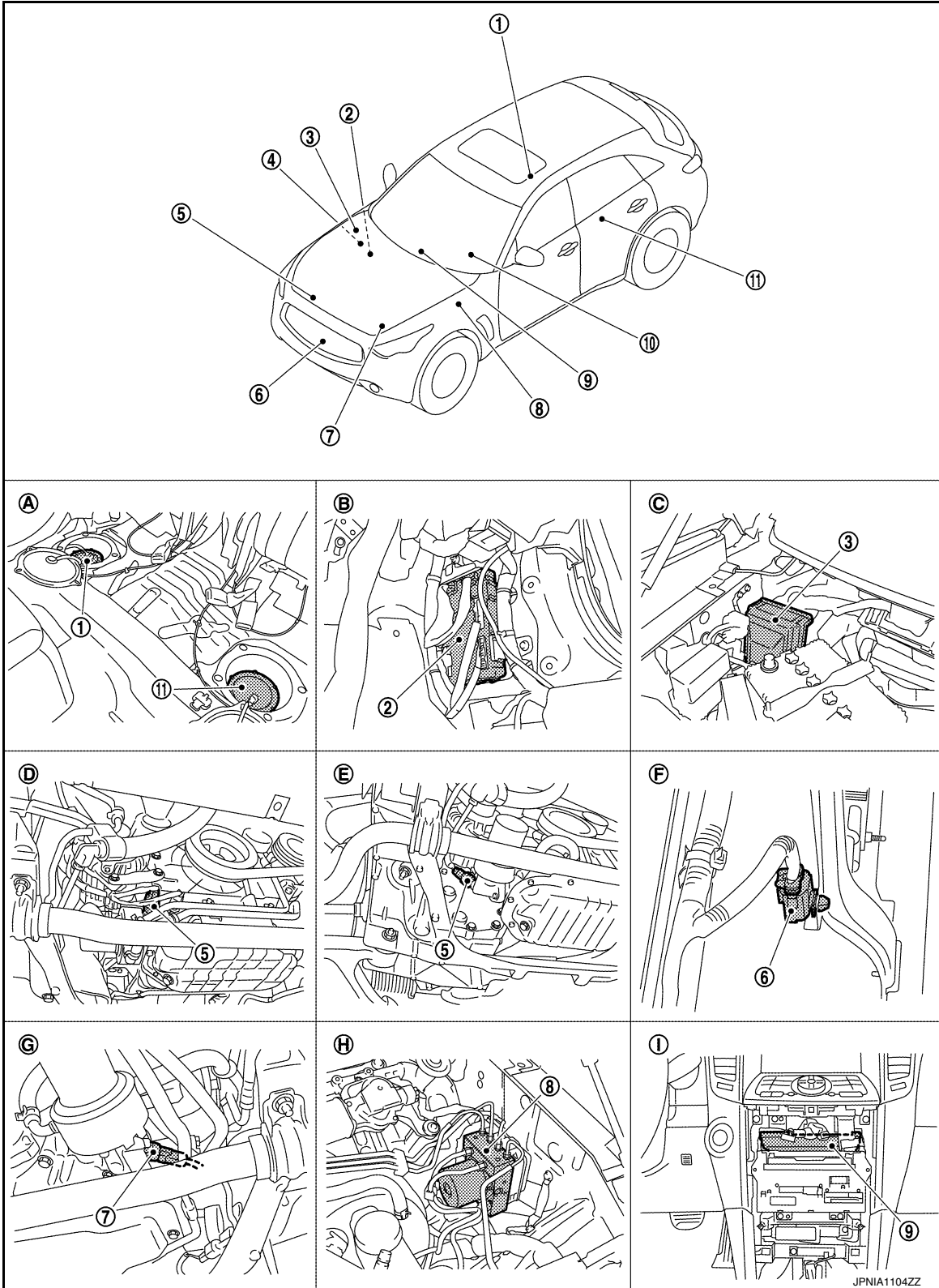

A
B
C
D
E
F
G
H
I
J
K
L
M
MWI
O
P

METER SYSTEM

< SYSTEM DESCRIPTION >

- | | | |
|--|--|-------------------------------|
| 1. Fuel level sensor unit and fuel pump (main) | 2. BCM | 3. IPDM E/R |
| 4. ECM : EC-51, "Component Parts Location" (VQ37VHR for USA and Canada)
ECM : EC-654, "Component Parts Location" (VQ37VHR for Mexico)
ECM : EC-1149, "Component Parts Location" (VK50VE engine models) | 5. Oil pressure switch (VQ37VHR engine models) | 6. Ambient sensor |
| 7. Oil pressure switch (VK50VE engine models) | 8. ABS actuator and electric unit (control unit) | 9. Unified meter and A/C amp. |
| 10. Combination meter | 11. Fuel level sensor unit (sub) | |
| A. Rear seat (bottom) | B. Dash side finisher (passenger side) | C. Hoodledge cover (RH) |
| D. 2WD [oil pan (upper) RH side] | E. AWD [oil filter bracket part (VQ37VHR engine models)] | F. Condenser (front) |
| G. AWD [oil filter bracket part (VK50VE engine models)] | H. Hoodledge cover (LH) | I. Behind cluster lid C |

ENGINE COOLANT TEMPERATURE GAUGE : Component Description

INFOID:0000000010577000

Unit	Description
Combination meter	Indicates the engine coolant temperature gauge according to the engine coolant temperature signal received from the unified meter and A/C amp. by means of communication line.
Unified meter and A/C amp.	Transmits the engine coolant temperature signal received from ECM with CAN communication line to the combination meter by means of communication line.
ECM	Transmits the engine coolant temperature signal to the unified meter and A/C amp. with CAN communication line.

FUEL GAUGE

FUEL GAUGE : System Diagram

INFOID:0000000010577001

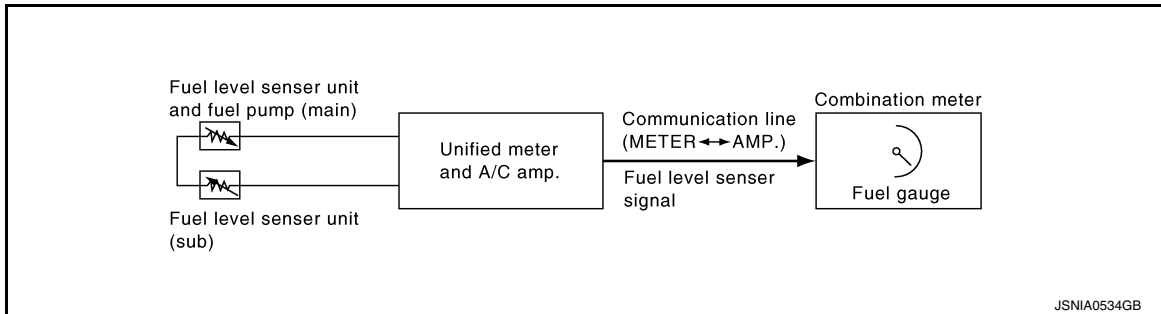

FUEL GAUGE : System Description

INFOID:0000000010577002

CONTROL OUTLINE

- The unified meter and A/C amp. reads the fuel level sensor signal from the fuel gauge unit and transmits it to the combination meter with the communication line.
- The combination meter indicates the fuel level on the fuel gauge according to the received fuel level sensor signal.

REFUEL CONTROL

The combination meter accelerates the fuel gauge segment if the all conditions listed below are met, or the ignition switch is ON from OFF.

- Ignition switch is ON position.
- The vehicle is not moving.
- The fuel level change by 15 ℓ (4 US gal, 3-3/10 Imp gal) or more.

METER SYSTEM

< SYSTEM DESCRIPTION >

FUEL GAUGE : Component Parts Location

INFOID:0000000110577003

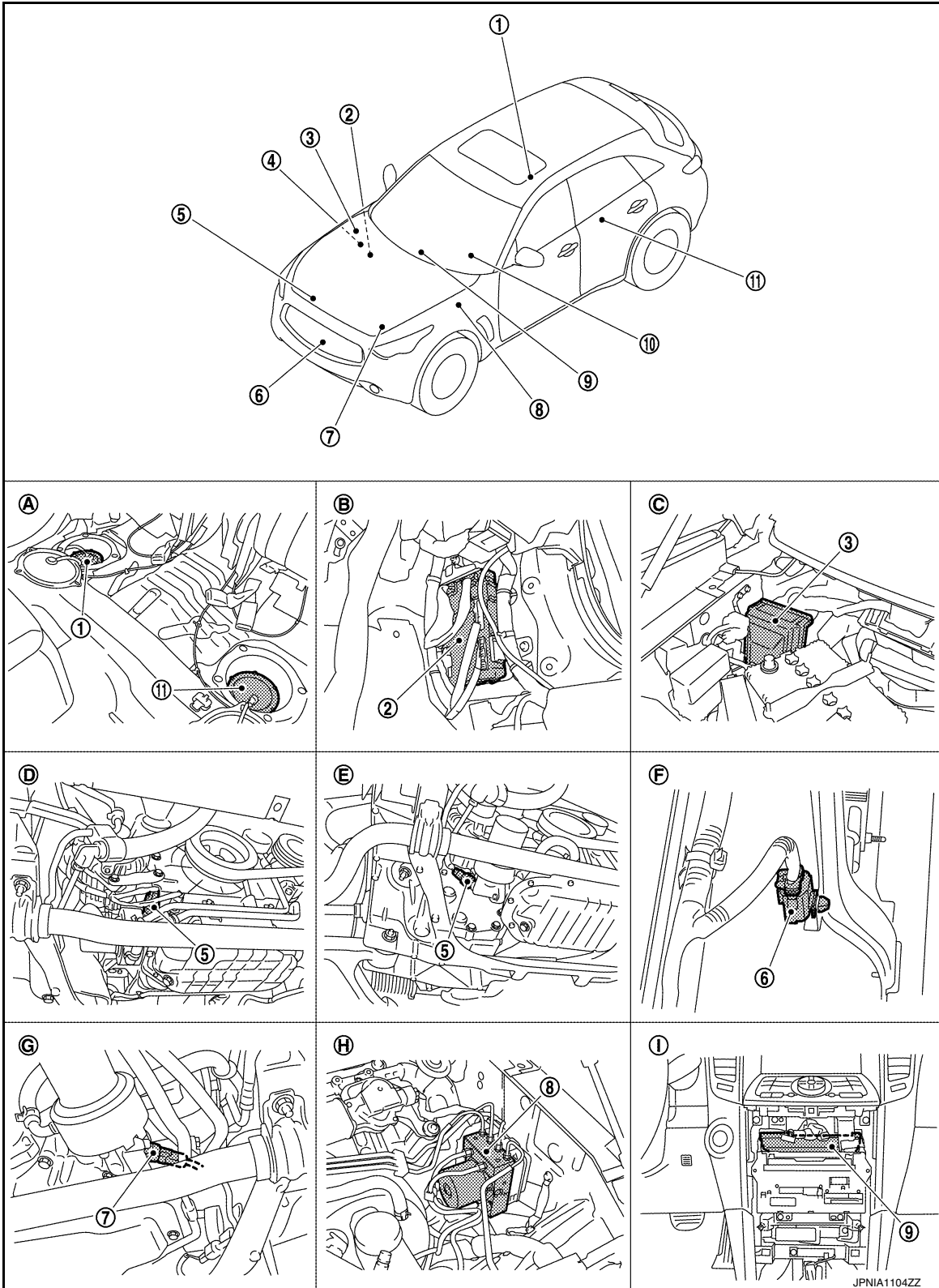

A
B
C
D
E
F
G
H
I
J
K
L
M
N
O
P

MWI

METER SYSTEM

< SYSTEM DESCRIPTION >

- | | | |
|--|--|-------------------------------|
| 1. Fuel level sensor unit and fuel pump (main) | 2. BCM | 3. IPDM E/R |
| 4. ECM : EC-51, "Component Parts Location" (VQ37VHR for USA and Canada)
ECM : EC-654, "Component Parts Location" (VQ37VHR for Mexico)
ECM : EC-1149, "Component Parts Location" (VK50VE engine models) | 5. Oil pressure switch (VQ37VHR engine models) | 6. Ambient sensor |
| 7. Oil pressure switch (VK50VE engine models) | 8. ABS actuator and electric unit (control unit) | 9. Unified meter and A/C amp. |
| 10. Combination meter | 11. Fuel level sensor unit (sub) | |
| A. Rear seat (bottom) | B. Dash side finisher (passenger side) | C. Hoodledge cover (RH) |
| D. 2WD [oil pan (upper) RH side] | E. AWD [oil filter bracket part (VQ37VHR engine models)] | F. Condenser (front) |
| G. AWD [oil filter bracket part (VK50VE engine models)] | H. Hoodledge cover (LH) | I. Behind cluster lid C |

FUEL GAUGE : Component Description

INFOID:000000010577004

Unit	Description
Combination meter	Indicates the fuel gauge according to the fuel level sensor signal received from the unified meter and A/C amp. by means of communication line.
Unified meter and A/C amp.	Transmits the fuel level sensor signal from the fuel level sensor unit to the combination meter by means of communication line.
Fuel level sensor unit	Refer to MWI-61, "Description" .

ODO/TRIP METER

ODO/TRIP METER : System Diagram

INFOID:000000010577005

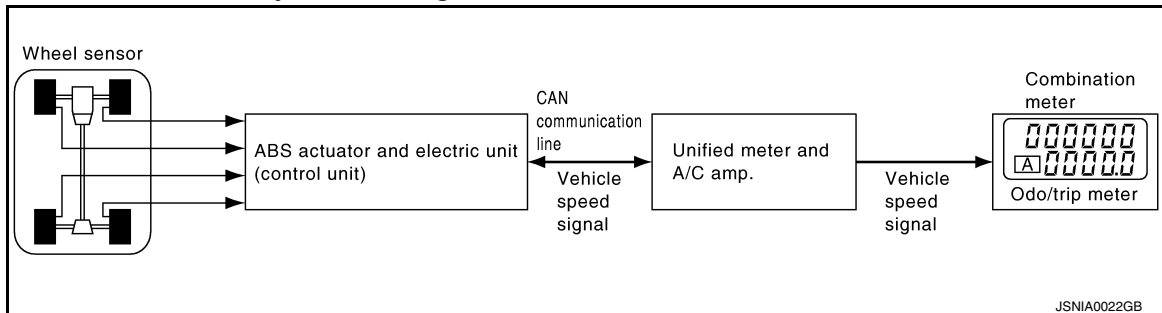

ODO/TRIP METER : System Description

INFOID:000000010577006

- The unified meter and A/C amp. transmits the vehicle speed signal from ABS actuator and electric unit (control unit) to the combination meter.
- The combination meter calculates the vehicle distance according to the vehicle speed signal. The vehicle distance is displayed.

METER SYSTEM

< SYSTEM DESCRIPTION >

ODO/TRIP METER : Component Parts Location

INFOID:0000000110577007

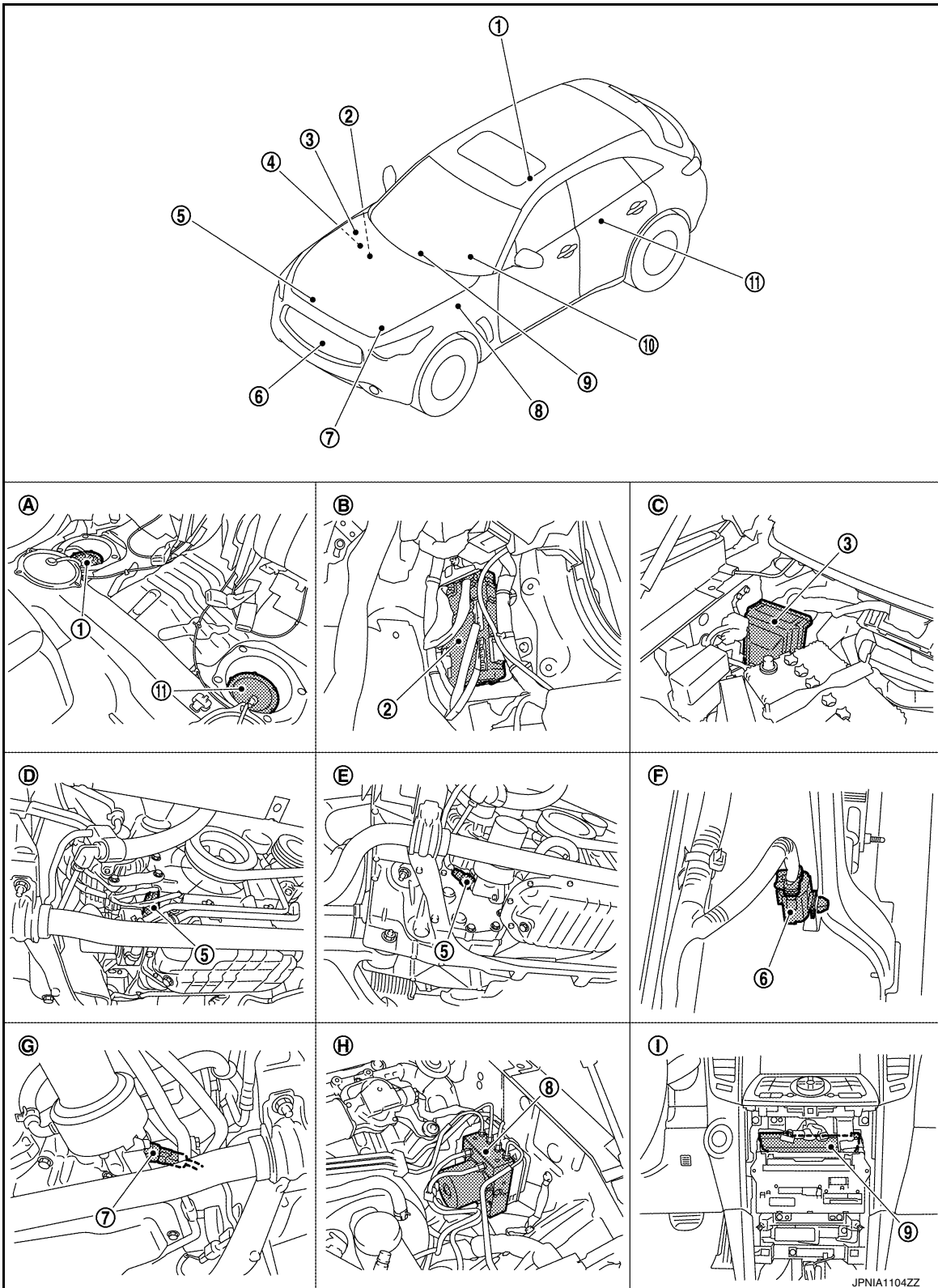

A
B
C
D
E
F
G
H
I
J
K
L
M
MWI
O
P

METER SYSTEM

< SYSTEM DESCRIPTION >

- | | | |
|--|--|-------------------------------|
| 1. Fuel level sensor unit and fuel pump (main) | 2. BCM | 3. IPDM E/R |
| 4. ECM : EC-51, "Component Parts Location" (VQ37VHR for USA and Canada)
ECM : EC-654, "Component Parts Location" (VQ37VHR for Mexico)
ECM : EC-1149, "Component Parts Location" (VK50VE engine models) | 5. Oil pressure switch (VQ37VHR engine models) | 6. Ambient sensor |
| 7. Oil pressure switch (VK50VE engine models) | 8. ABS actuator and electric unit (control unit) | 9. Unified meter and A/C amp. |
| 10. Combination meter | 11. Fuel level sensor unit (sub) | |
| A. Rear seat (bottom) | B. Dash side finisher (passenger side) | C. Hoodledge cover (RH) |
| D. 2WD [oil pan (upper) RH side] | E. AWD [oil filter bracket part (VQ37VHR engine models)] | F. Condenser (front) |
| G. AWD [oil filter bracket part (VK50VE engine models)] | H. Hoodledge cover (LH) | I. Behind cluster lid C |

ODO/TRIP METER : Component Description

INFOID:000000010577008

Unit	Description
Combination meter	The combination meter calculates the vehicle distance according to the vehicle speed signal. The vehicle distance is displayed.
Unified meter and A/C amp.	The unified meter and A/C amp. transmits the vehicle speed signal from ABS actuator and electric unit (control unit) to the combination meter.
ABS actuator and electric unit (control unit)	Transmits the vehicle speed signal to the unified meter and A/C amp. with CAN communication line.

SHIFT POSITION INDICATOR

SHIFT POSITION INDICATOR : System Diagram

INFOID:000000010577009

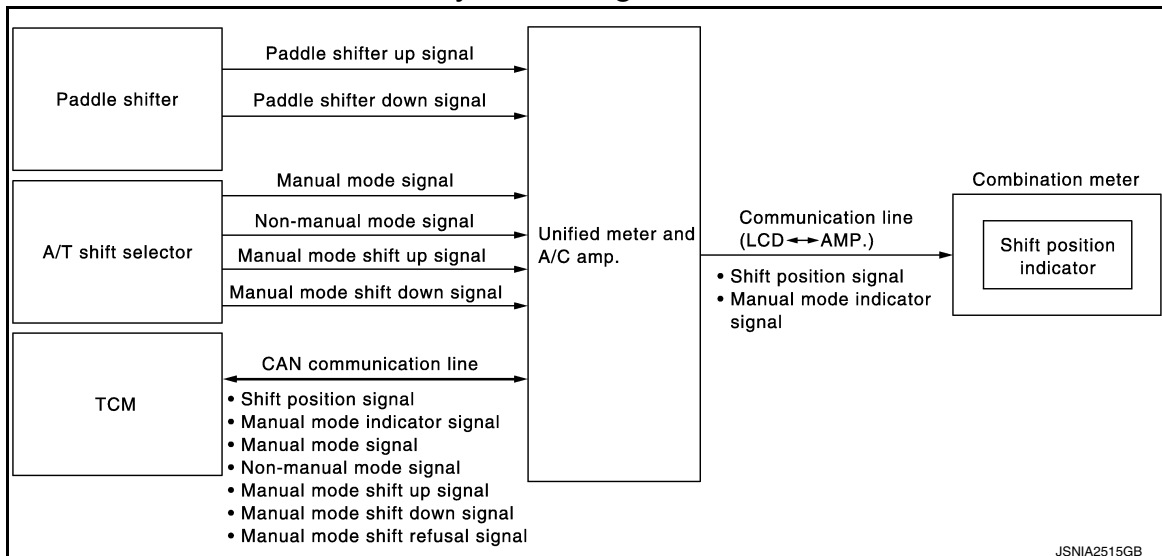

SHIFT POSITION INDICATOR : System Description

INFOID:000000010577010

Shift position is displayed in the information display LCD in the combination meter.

MANUAL MODE

When Operated with A/T Shift Selector

- Unified meter and A/C amp. inputs manual mode signal and manual mode shift-up/down signal from A/T shift selector (manual mode switch), and transmits the signals to TCM with CAN communication line.

METER SYSTEM

< SYSTEM DESCRIPTION >

- TCM processes manual mode signal and manual mode shift-up/down signal, and transmits manual mode indicator signal and shift position signal to unified meter and A/C amp. with CAN communication line. A
- Unified meter and A/C amp. transmits manual mode indicator signal and shift position signal to combination meter with the communication line.
- Combination meter indicates A/T gear position and manual mode indicator, when receiving manual mode indicator signal and shift position signal. B

When Operated with Paddle Shifter

- Unified meter and A/C amp. inputs manual mode signal from A/T shift selector (manual mode switch) or the paddle shifter-up/down signal from the paddle shifter. C
- Unified meter and A/C amp. transmits manual mode signal and manual mode shift-up/down signal to TCM with the CAN communication line.
- TCM processes manual mode signal and manual mode shift-up/down signal, and transmits manual mode indicator signal and shift position signal to unified meter and A/C amp. with CAN communication line. D
- Unified meter and A/C amp. transmits manual mode indicator signal and shift position signal to combination meter with the communication line. E
- Combination meter indicates A/T gear position and manual mode indicator, when receiving manual mode indicator signal and shift position signal.

NON-MANUAL MODE

- Unified meter and A/C amp. inputs non-manual mode signal from A/T shift selector (manual mode switch), and transmits the signals to TCM with CAN communication line. F
- TCM transmits shift position signal to unified meter and A/C amp. with CAN communication line. G
- Unified meter and A/C amp. transmits shift position signal to combination meter with the communication line.
- Combination meter indicates shift position when receiving shift position signal. H

A
B
C
D
E
F
G
H
I
J
K
L
M
O
P

MWI

METER SYSTEM

< SYSTEM DESCRIPTION >

SHIFT POSITION INDICATOR : Component Parts Location

INFOID:000000010577011

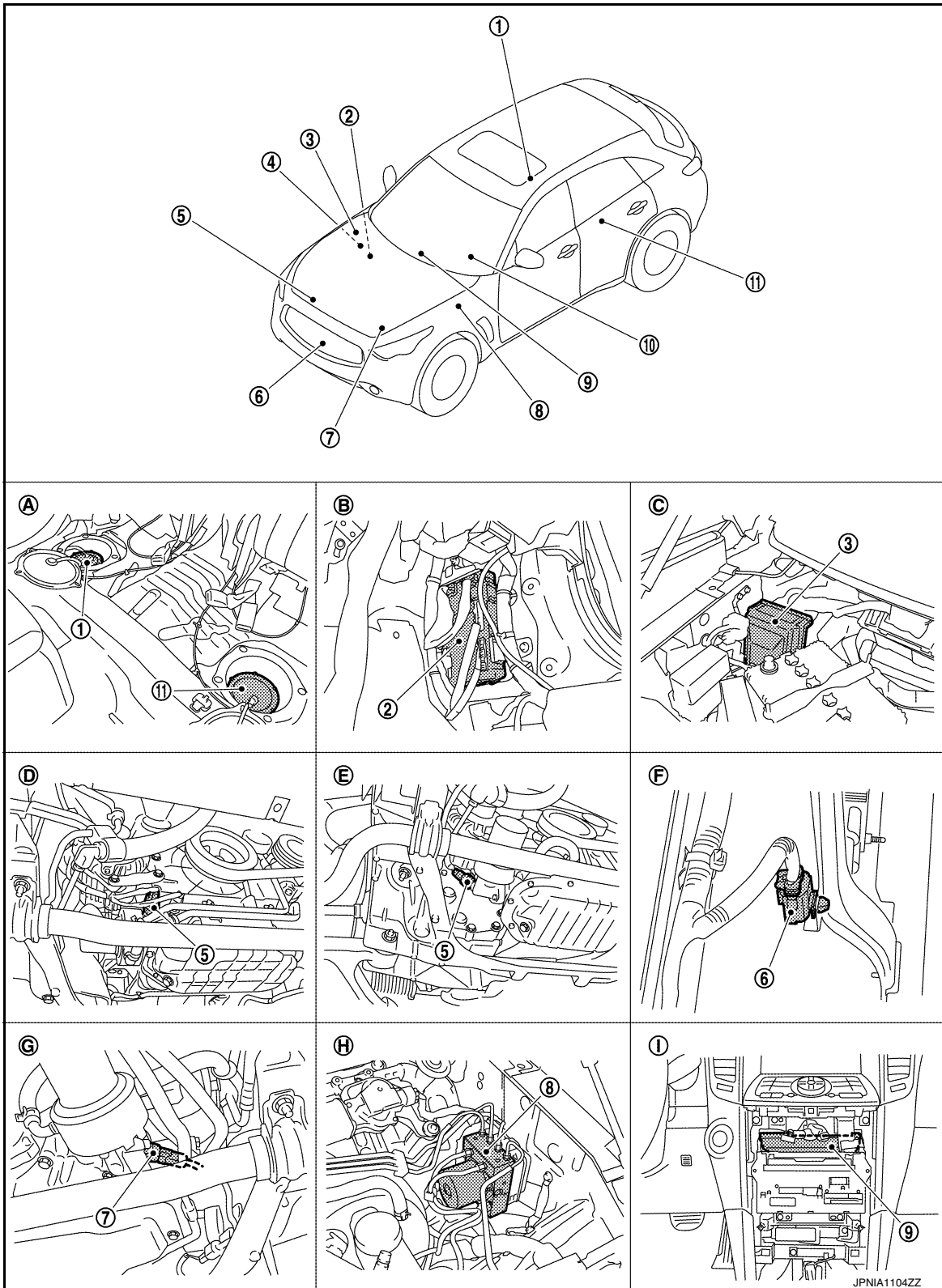

METER SYSTEM

< SYSTEM DESCRIPTION >

- | | | |
|--|--|-------------------------------|
| 1. Fuel level sensor unit and fuel pump (main) | 2. BCM | 3. IPDM E/R |
| 4. ECM : EC-51, "Component Parts Location" (VQ37VHR for USA and Canada)
ECM : EC-654, "Component Parts Location" (VQ37VHR for Mexico)
ECM : EC-1149, "Component Parts Location" (VK50VE engine models) | 5. Oil pressure switch (VQ37VHR engine models) | 6. Ambient sensor |
| 7. Oil pressure switch (VK50VE engine models) | 8. ABS actuator and electric unit (control unit) | 9. Unified meter and A/C amp. |
| 10. Combination meter | 11. Fuel level sensor unit (sub) | |
| A. Rear seat (bottom) | B. Dash side finisher (passenger side) | C. Hoodledge cover (RH) |
| D. 2WD [oil pan (upper) RH side] | E. AWD [oil filter bracket part (VQ37VHR engine models)] | F. Condenser (front) |
| G. AWD [oil filter bracket part (VK50VE engine models)] | H. Hoodledge cover (LH) | I. Behind cluster lid C |

SHIFT POSITION INDICATOR : Component Description

INFOID:000000010577012

Unit	Description
Combination meter	Displays the shift position on the information display with shift position signal and manual mode indicator signal received from unified meter and A/C amp.
Unified meter and A/C amp.	<ul style="list-style-type: none"> Transmits the signals from the A/T shift selector and paddle shifter to TCM with CAN communication line. Transmits shift position signal and manual mode indicator signal received from TCM with CAN communication line to the combination meter by means of communication line.
A/T shift selector	Transmits the following signals to the unified meter and A/C amp. <ul style="list-style-type: none"> Manual mode signal Manual mode shift up signal Non-manual mode signal Manual mode shift down signal
Paddle shifter	Transmits the paddle shifter up signal and paddle shifter down signal to the unified meter and A/C amp.
TCM	Transmits shift position signal and manual mode indicator signal to the unified meter and A/C amp.

WARNING LAMPS/INDICATOR LAMPS

WARNING LAMPS/INDICATOR LAMPS : System Diagram

INFOID:000000010577013

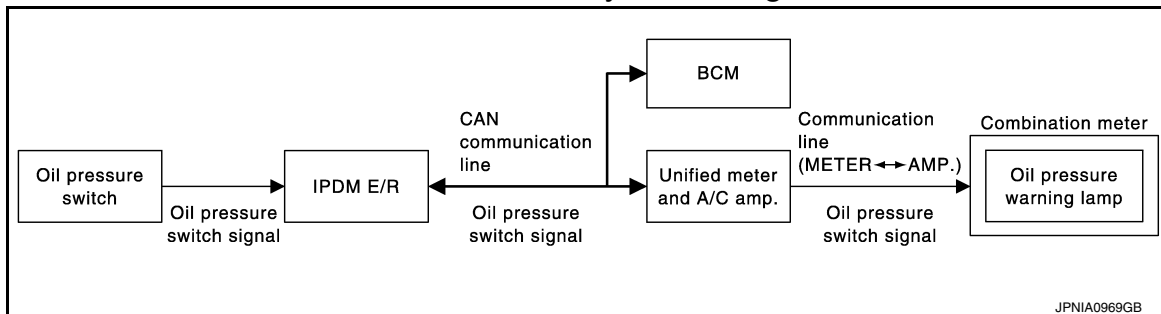

WARNING LAMPS/INDICATOR LAMPS : System Description

INFOID:000000010577014

OIL PRESSURE WARNING LAMP

- IPDM E/R inputs oil pressure switch signal from oil pressure switch, and transmits the signal to unified meter and A/C amp. through BCM with CAN communication line.
- Unified meter and A/C amp. transmits oil pressure switch signal to combination meter with communication line.
- Let the combination meter turn oil pressure warning lamp ON with received oil pressure switch signal.

METER SYSTEM

< SYSTEM DESCRIPTION >

WARNING LAMPS/INDICATOR LAMPS : Component Parts Location

INFOID:000000010577015

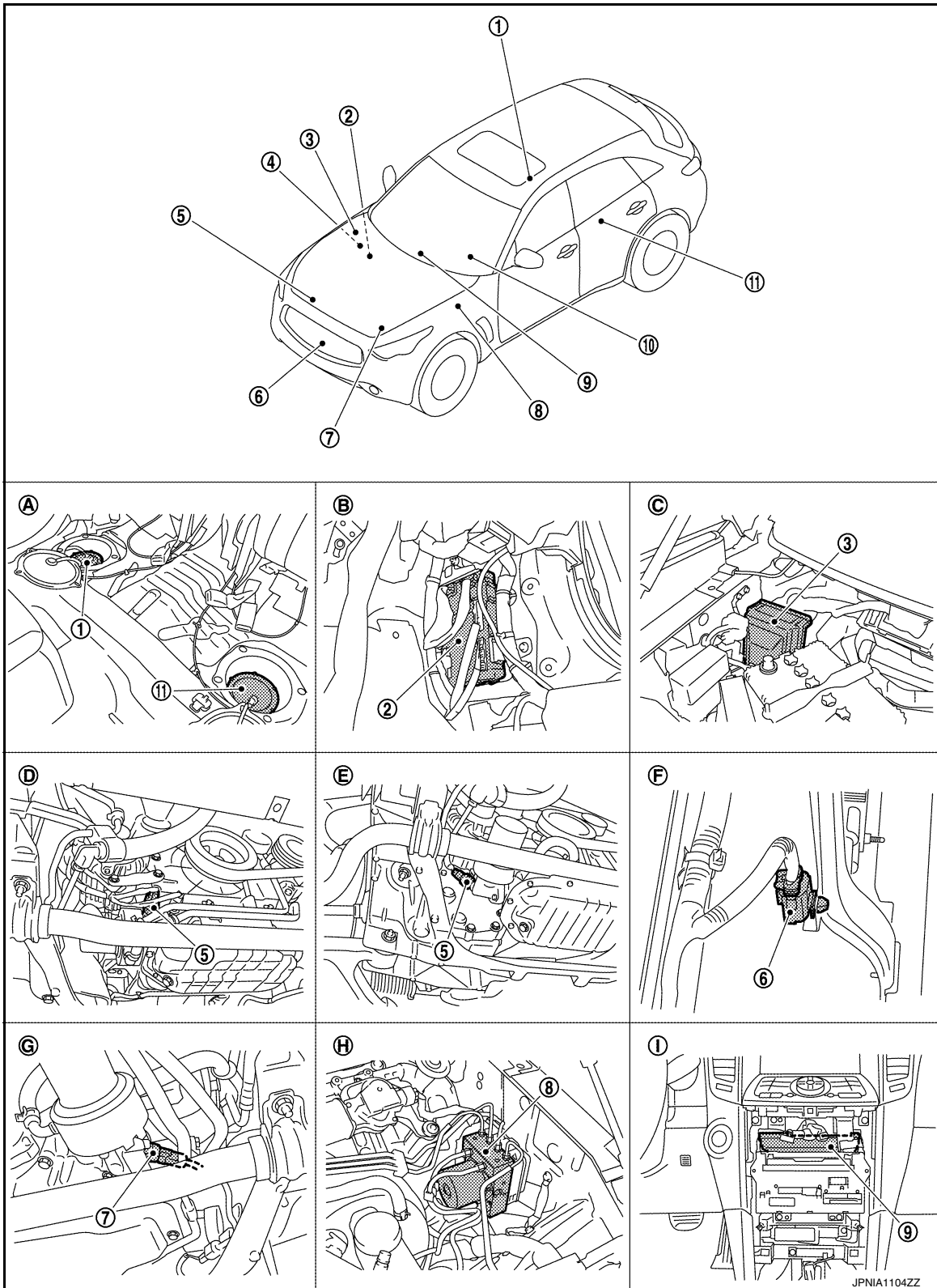

METER SYSTEM

< SYSTEM DESCRIPTION >

- | | | |
|--|--|-------------------------------|
| 1. Fuel level sensor unit and fuel pump (main) | 2. BCM | 3. IPDM E/R |
| 4. ECM : EC-51, "Component Parts Location" (VQ37VHR for USA and Canada)
ECM : EC-654, "Component Parts Location" (VQ37VHR for Mexico)
ECM : EC-1149, "Component Parts Location" (VK50VE engine models) | 5. Oil pressure switch (VQ37VHR engine models) | 6. Ambient sensor |
| 7. Oil pressure switch (VK50VE engine models) | 8. ABS actuator and electric unit (control unit) | 9. Unified meter and A/C amp. |
| 10. Combination meter | 11. Fuel level sensor unit (sub) | |
| A. Rear seat (bottom) | B. Dash side finisher (passenger side) | C. Hoodledge cover (RH) |
| D. 2WD [oil pan (upper) RH side] | E. AWD [oil filter bracket part (VQ37VHR engine models)] | F. Condenser (front) |
| G. AWD [oil filter bracket part (VK50VE engine models)] | H. Hoodledge cover (LH) | I. Behind cluster lid C |

WARNING LAMPS/INDICATOR LAMPS : Component Description

INFOID:000000010577016

Unit	Description
Combination meter	Turns the oil pressure warning lamp ON/OFF according to the oil pressure switch signal received from the unified meter and A/C amp. by means of communication line.
Unified meter and A/C amp.	Transmits the oil pressure switch signal received from the IPDM E/R with BCM to the combination meter by means of communication line.
IPDM E/R	IPDM E/R reads the ON/OFF signals from the oil pressure switch and transmits the oil pressure switch signal to the unified meter and A/C amp. via BCM with the CAN communication line.
Oil pressure switch	Refer to MWI-69, "Description" .
BCM	Transmits the oil pressure switch signal received from IPDM E/R via CAN communication to the unified meter and A/C amp. via CAN communication line.

METER ILLUMINATION CONTROL

METER ILLUMINATION CONTROL : System Diagram

INFOID:000000010577017

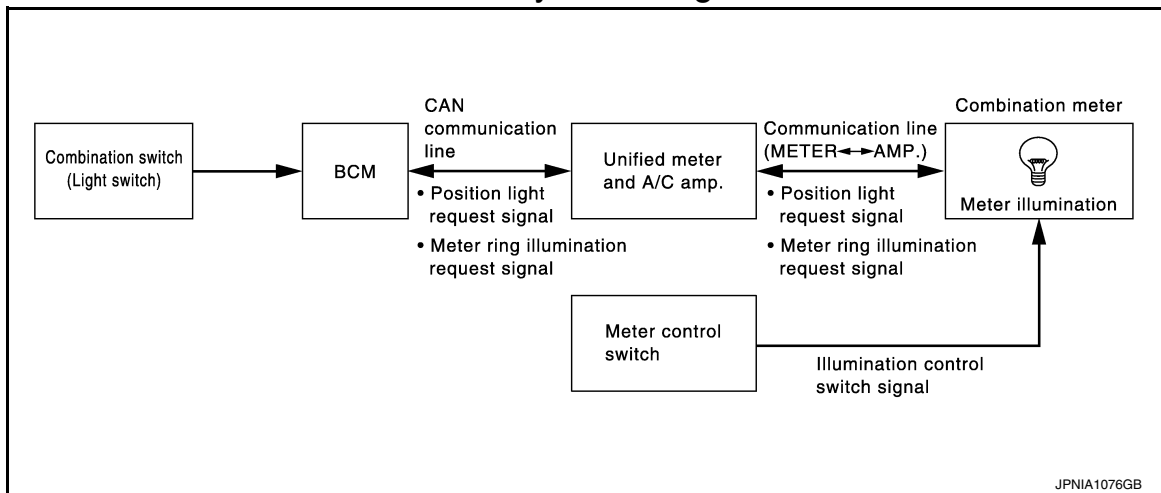

METER ILLUMINATION CONTROL : System Description

INFOID:000000010577018

SYSTEM DESCRIPTION

The combination meter receives an illumination control switch signal from the meter control switch, and a position light request signal and a meter ring illumination request signal from BCM through the unified meter and A/C amp. to control meter illumination.

METER SYSTEM

< SYSTEM DESCRIPTION >

Daytime Mode

Meter illumination is adjusted to 5 steps by illumination control switch (1) in daytime mode.

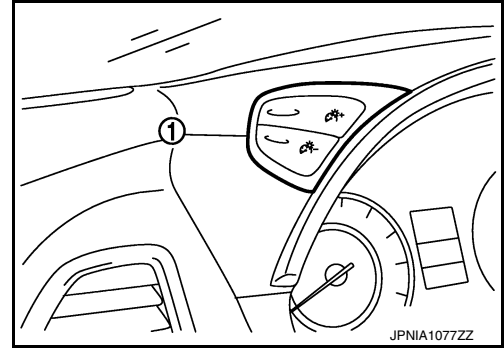

Nighttime Mode

- Combination meter is transferred to nighttime mode with position light request signal from BCM with CAN communication line.
- Meter illumination is adjusted to 22 steps by illumination control switch in nighttime.

Driver Welcome Function

- BCM transmits a meter ring illumination request signal to the unified meter and A/C amp. through the CAN communication when the intelligent key is inside the vehicle and the door on the driver side is recognized as closed.
- The unified meter and A/C amp. receives a meter ring illumination request signal through the CAN communication and transmits the signal to the combination meter with communication line.
- The combination meter turns on meter ring illumination in stages by receiving a meter ring illumination request signal from the unified meter and A/C amp. through the communication line.

NOTE:

Meter ring illumination turns off in stages after a set period of time.

METER SYSTEM

< SYSTEM DESCRIPTION >

METER ILLUMINATION CONTROL : Component Parts Location

INFOID:000000010577019

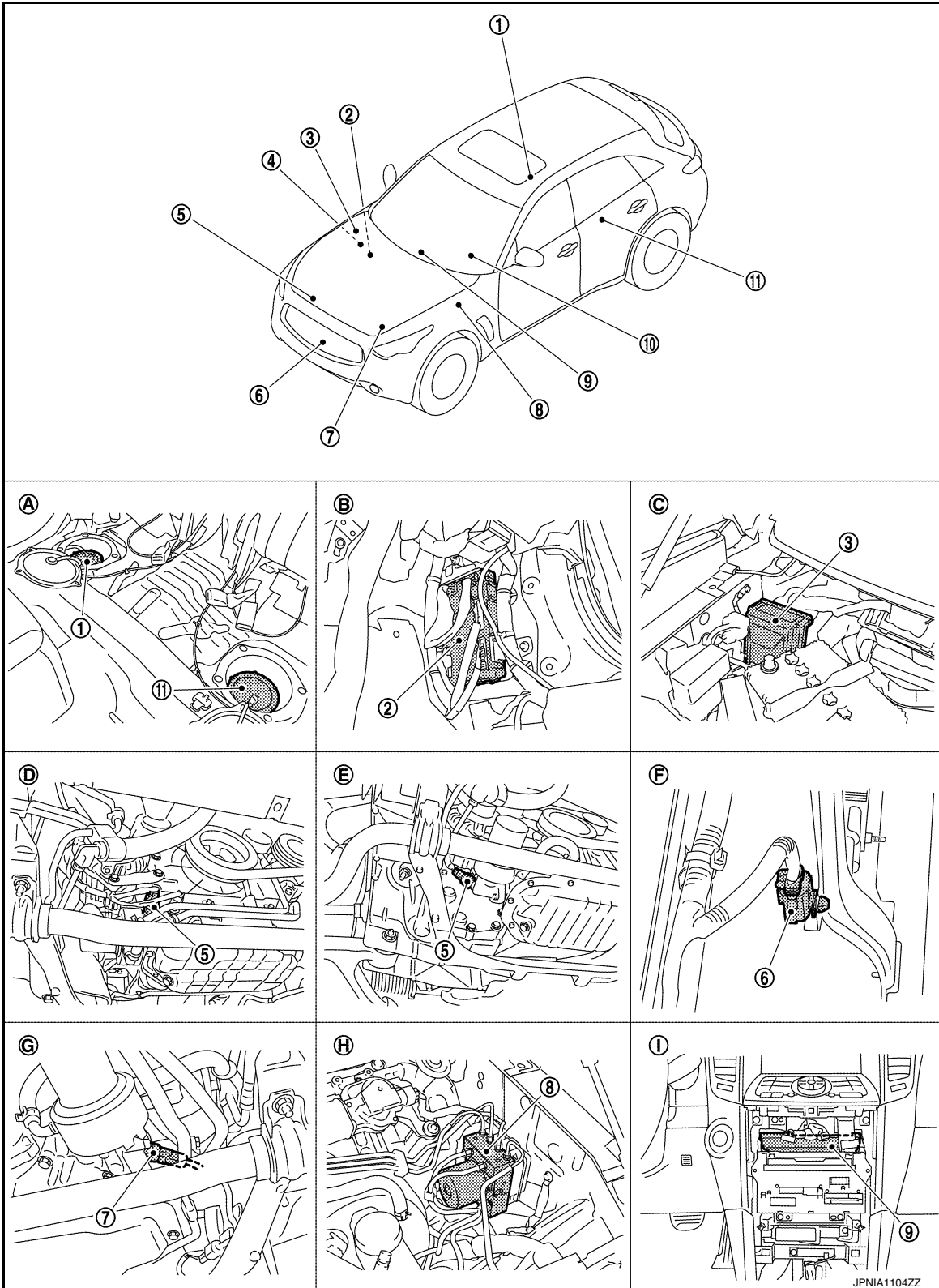

A
B
C
D
E
F
G
H
I
J
K
L
M
MWI
O
P

METER SYSTEM

< SYSTEM DESCRIPTION >

- | | | |
|--|--|-------------------------------|
| 1. Fuel level sensor unit and fuel pump (main) | 2. BCM | 3. IPDM E/R |
| 4. ECM : EC-51, "Component Parts Location" (VQ37VHR for USA and Canada)
ECM : EC-654, "Component Parts Location" (VQ37VHR for Mexico)
ECM : EC-1149, "Component Parts Location" (VK50VE engine models) | 5. Oil pressure switch (VQ37VHR engine models) | 6. Ambient sensor |
| 7. Oil pressure switch (VK50VE engine models) | 8. ABS actuator and electric unit (control unit) | 9. Unified meter and A/C amp. |
| 10. Combination meter | 11. Fuel level sensor unit (sub) | |
| A. Rear seat (bottom) | B. Dash side finisher (passenger side) | C. Hoodledge cover (RH) |
| D. 2WD [oil pan (upper) RH side] | E. AWD [oil filter bracket part (VQ37VHR engine models)] | F. Condenser (front) |
| G. AWD [oil filter bracket part (VK50VE engine models)] | H. Hoodledge cover (LH) | I. Behind cluster lid C |

METER ILLUMINATION CONTROL : Component Description

INFOID:000000010577020

Unit	Description
Combination meter	Controls the meter illumination with the illumination control switch signal from the meter control switch and the position light request signal and the meter ring illumination request signal from unified meter and A/C amp.
Unified meter and A/C amp.	Transmits the position light request signal and meter ring illumination request signal received from BCM via CAN communication to the combination meter by means of communication.
BCM	Transmits the following signals to the unified meter and A/C amp. <ul style="list-style-type: none"> • Position light request signal • Meter ring illumination request signal
Meter control switch	Transmits the following signals to the combination meter. <ul style="list-style-type: none"> • Illumination control switch signal (+) • Illumination control switch signal (-)

METER EFFECT FUNCTION

METER EFFECT FUNCTION : System Diagram

INFOID:000000010577021

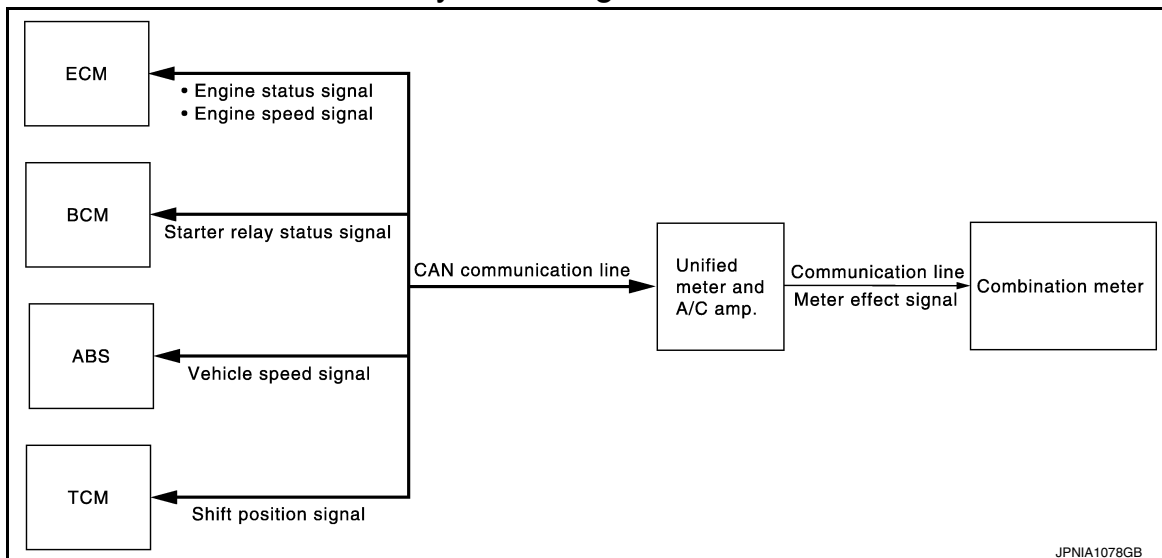

METER EFFECT FUNCTION : System Description

INFOID:000000010577022

SYSTEM DESCRIPTION

METER SYSTEM

< SYSTEM DESCRIPTION >

Engine-start Effect function

- The unified meter and A/C amp. receives an engine speed signal and engine status signal from ECM, a starter relay status signal from BCM, a shift position signal from TCM, a vehicle speed signal from ABS actuator and electric unit (control unit) through the use of the CAN communication. After the end of cranking and recognition of engine revolution, the unified meter and A/C amp. transmits a meter effect signal to the combination meter through the communication line.
- Receiving a meter effect signal, the combination meter illuminates the meter light in stages and sweeps the needles of the speedometer and the tachometer.

NOTE:

The engine-start effect function enables ON/OFF with an operation of information display.

Cancel Conditions

- Meter effect is not performed during driving.
- Meter effect is not performed except when in P-range.

NOTE:

Meter effect is cancelled when the vehicle is moved during meter effect or the shift lever is shifted to the range except for P-range.

Ignition Switch OFF Effect Function

The unified meter and A/C amp. transmits a meter effect signal to the combination meter through the communication line when ignition switch is turned from ON to OFF. Receiving a meter effect signal, the combination meter turns off the meter illumination in stages. Illumination for the needle is turned off after the meter illumination is turned off.

A
B
C
D
E
F
G
H
I
J
K
L
M
O
P

MWI

METER SYSTEM

< SYSTEM DESCRIPTION >

METER EFFECT FUNCTION : Component Parts Location

INFOID:000000010577023

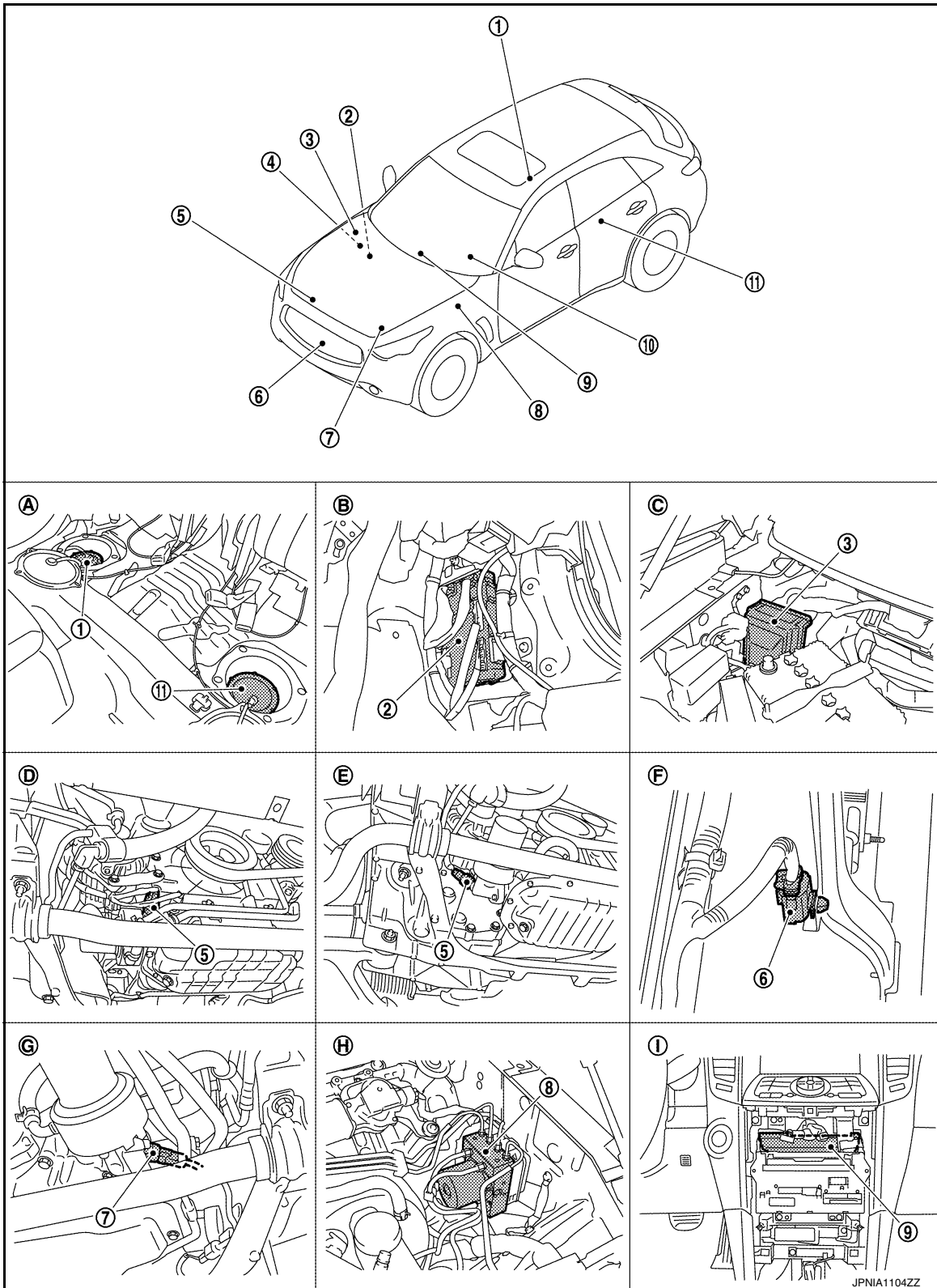

METER SYSTEM

< SYSTEM DESCRIPTION >

- | | | |
|--|--|-------------------------------|
| 1. Fuel level sensor unit and fuel pump (main) | 2. BCM | 3. IPDM E/R |
| 4. ECM : EC-51, "Component Parts Location" (VQ37VHR for USA and Canada)
ECM : EC-654, "Component Parts Location" (VQ37VHR for Mexico)
ECM : EC-1149, "Component Parts Location" (VK50VE engine models) | 5. Oil pressure switch (VQ37VHR engine models) | 6. Ambient sensor |
| 7. Oil pressure switch (VK50VE engine models) | 8. ABS actuator and electric unit (control unit) | 9. Unified meter and A/C amp. |
| 10. Combination meter | 11. Fuel level sensor unit (sub) | |
| A. Rear seat (bottom) | B. Dash side finisher (passenger side) | C. Hoodledge cover (RH) |
| D. 2WD [oil pan (upper) RH side] | E. AWD [oil filter bracket part (VQ37VHR engine models)] | F. Condenser (front) |
| G. AWD [oil filter bracket part (VK50VE engine models)] | H. Hoodledge cover (LH) | I. Behind cluster lid C |

METER EFFECT FUNCTION : Component Description

INFOID:0000000010577024

Unit	Description
Combination meter	Receives a meter effect signal through the unified meter and A/C amp. and performs meter effect.
Unified meter and A/C amp.	Receives signals from each unit with the CAN communication and transmits a meter effect signal to the combination meter through the communication line.
ECM	Transmits an engine speed signal and an engine status signal to the unified meter and A/C amp. with the CAN communication.
BCM	Transmits a starter relay status signal to the unified meter and A/C amp. with the CAN communication.
ABS actuator and electric unit (control unit)	Transmits a vehicle speed signal to the unified meter and A/C amp. with the CAN communication.
TCM	Transmits a shift position signal to the unified meter and A/C amp. with the CAN communication.

INFORMATION DISPLAY

INFORMATION DISPLAY : System Diagram

INFOID:0000000010577025

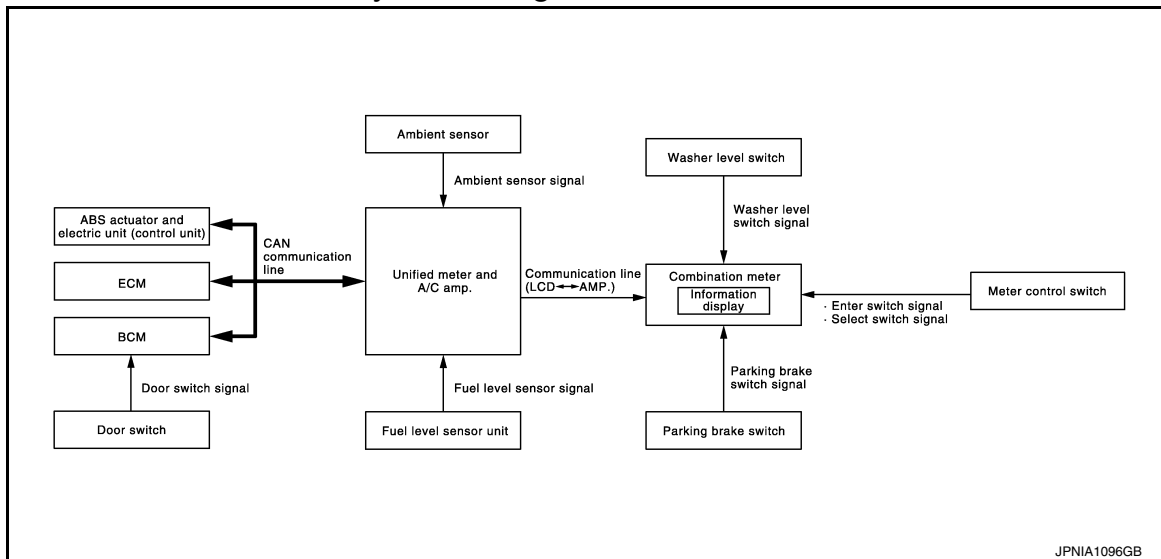

INFORMATION DISPLAY : System Description

INFOID:0000000010577026

DESCRIPTION

METER SYSTEM

< SYSTEM DESCRIPTION >

- The combination meter retrieves the information required for controlling the operations of the information display from the communication signals from the unified meter and A/C amp., etc.
- The combination meter incorporates a trip computer that displays the warning / information according to the information received from various units.

PARKING BRAKE RELEASE WARNING

The combination meter indicates parking brake release warning judged with the vehicle speed signal received from the unified meter and A/C amp. by means of communication line and the parking brake switch signal from the parking brake switch.

Warning Operation Condition

Parking brake release warning is judged if all of the following conditions are fulfilled

- Vehicle speed is 7 km/h (4.3 MPH) or higher
- Parking brake switch ON

LOW FUEL WARNING

The combination meter indicates low fuel warning judged with the fuel level sensor signal received from the unified meter and A/C amp.

Warning Operation Condition

Fuel level: Approx. 13.7 ℓ (3 - 5/8 US gal, 3 Imp gal) or less [3.1 ℓ (7/8 US gal, 5/8 Imp gal) fuel residues included.]

LOW WASHER FLUID WARNING

The combination meter indicates low washer fluid warning judged with the signal from the washer level switch.

Warning Operation Condition

- Indicates the warning when it is in washer level switch ON condition for 180 seconds or more. Release the warning when it is in washer level switch OFF condition for 30 seconds or more.

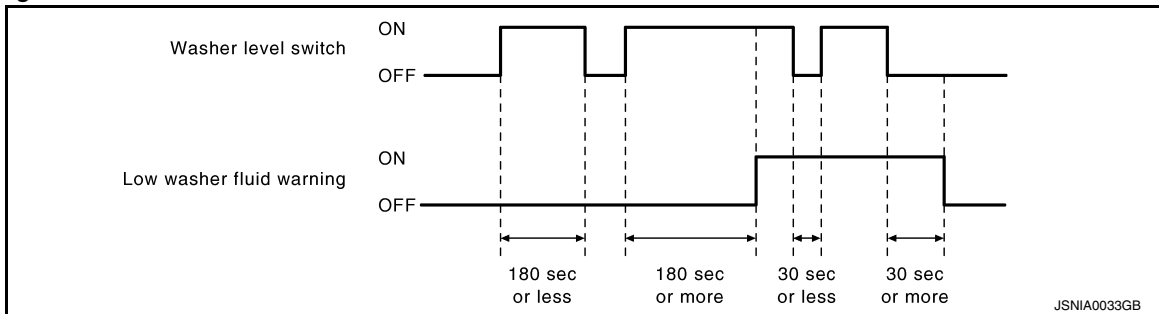

LOW OUTSIDE TEMPERATURE WARNING

The combination meter indicates low outside temperature warning judged with the ambient sensor signal received from the unified meter and A/C amp. by means of communication line.

DOOR OPEN WARNING

The combination meter indicates door open warning judged with each door switch signal received from the unified meter and A/C amp. by means of communication line.

LOW TIRE PRESSURE WARNING

- The unified meter and A/C amp. receives remaining low tire pressure warning lamp signal from the BCM with CAN communication line.
 - The unified meter and A/C amp. transmits remaining low tire pressure warning lamp signal to the combination meter with communication line.
 - The combination meter indicates low tire pressure warning when receiving remaining low tire pressure warning lamp signal.
 - The combination meter indicates low tire pressure warning judged with the low tire pressure warning lamp signal received from the unified meter and A/C amp.
- For details, refer to [WT-7. "System Description"](#).

FUEL FILLER CAP WARNING

- The unified meter and A/C amp. receives remaining fuel filler cap warning display signal from the ECM with CAN communication line.
- The unified meter and A/C amp. transmits remaining fuel filler cap warning display signal to the combination meter with communication line.

METER SYSTEM

< SYSTEM DESCRIPTION >

- The combination meter indicates fuel filler cap warning when receiving remaining fuel filler cap warning display signal. A
 - The combination meter indicates fuel filler cap warning judged with the fuel filler cap warning display signal received from the unified meter and A/C amp. B
- For details, refer to [EC-119, "System Description"](#) (VQ37VHR for USA and Canada).

INSTANTANEOUS FUEL CONSUMPTION

- The unified meter and A/C amp. receives the fuel consumption monitor signal from ECM and the vehicle speed signal from the ABS actuator and electric unit (control unit) with CAN communication line. C
- The unified meter and A/C amp. calculates the instantaneous fuel consumption according to the fuel consumption monitor signal and the vehicle speed signal received with CAN communication line, and transmits it to the combination meter. D

AVERAGE FUEL CONSUMPTION

- The unified meter and A/C amp. receives the fuel consumption monitor signal from ECM and the vehicle speed signal from the ABS actuator and electric unit (control unit) with CAN communication line. E
- The unified meter and A/C amp. calculates the average fuel consumption according to the fuel consumption monitor signal and the vehicle speed signal received with CAN communication line, and transmits it to the combination meter. F
- The average fuel consumption displayed on the information display is uploaded at approximately 30-second intervals.

NOTE:

When turning ON the ignition switch after triggering a reset or removing/installing the battery, “——” is indicated until 30 seconds/500 m (0.31 mile) of driving. G

AVERAGE VEHICLE SPEED

- The unified meter and A/C amp. receives the vehicle speed signal from the ABS actuator and electric unit (control unit) via CAN communication line. H
- Measures the time during the ignition switch ON with the unified meter and A/C amp.
- The unified meter and A/C amp. calculates the average vehicle speed according to the above signals. These signals are transmitted to the combination meter with the communication line. I
- The average vehicle speed displayed on the information display is uploaded at approximately 30-second intervals. J

NOTE:

When turning ON the ignition switch after triggering a reset or removing/installing the battery, “——” is indicated until 30 seconds/500 m (0.31 mile) of driving. K

TRAVEL TIME

Measures the time during the ignition switch ON with the unified meter and A/C amp, and transmits it to the combination meter by means of communication line. L

TRAVEL DISTANCE

- The unified meter and A/C amp. transmits the vehicle speed signal from ABS actuator and electric unit (control unit) to the combination meter. M
- The combination meter calculates the vehicle distance according to the vehicle speed signal. The vehicle distance is displayed.

POSSIBLE DRIVING DISTANCE

The unified meter and A/C amp. calculates possible driving distance according to the vehicle speed signal and fuel consumption monitor signal transmitted via CAN communication and the fuel level sensor signal transmitted from the fuel level sensor. These signals are transmitted to the combination meter with the communication line. MWI

NOTE:

- When turning ON the ignition switch after removing/installing the battery, “——” is indicated until 30 seconds. O
- The indicated values may not match each other when filling the fuel with the ignition switch ON. Refer to [MWI-140, "INFORMATION DISPLAY : Description"](#). P

AMBIENT AIR TEMPERATURE

- The unified meter and A/C amp. receives the ambient sensor signal from the ambient sensor.
- The unified meter and A/C amp. calculates the ambient temperature according to the ambient sensor signal, and transmits it to the combination meter.
- The indicated temperature does not increase if the vehicle speed is less than 20 km/h (12 MPH).

METER SYSTEM

< SYSTEM DESCRIPTION >

NOTE:

- The ambient sensor input value that is displayed on “Data Monitor” of CONSULT is the value before the correction. It may not match the indicated temperature on the information display.
- Ambient temperature may be indicated higher than an actual temperature, depending on heat in the engine, a road surface temperature, and so on.

SETTING

Setting item list

	Items	Setting range	Setting unit	Description
ALERT	TIME TO REST	No setting - 6 hours	30 minutes, [60 minutes]*	Time to rest is displayed on the information display if the vehicle reached the set travel distance.
	ICY	ON/OFF	—	Low outside temp is displayed on the information display if the ambient temperature is 3°C (37°F) or less.
MAINTENANCE	ENGINE OIL	No setting - 18,500 miles, (No setting - 30,000 km)	250 miles (500 km), [500 miles (1000 km)]*	The engine oil replacement interval is displayed on the information display if the vehicle reached the set distance.
	OIL FILTER	No setting - 18,500 miles, (No setting - 30,000 km)	250 miles (500 km), [500 miles (1000 km)]*	The oil filter replacement interval is displayed on the information display if the vehicle reached the set distance.
	TIRE	No setting - 18,500 miles, (No setting - 30,000 km)	250 miles (500 km), [500 miles (1000 km)]*	The tire replacement interval is displayed on the information display if the vehicle reached the set distance.
	OTHER	No setting - 18,500 miles, (No setting - 30,000 km)	250 miles (500 km), [500 miles (1000 km)]*	The other replacement interval is displayed on the information display if the vehicle reached the set distance.
CUSTOMIZE	LANGUAGE	ENGLISH/FRANCAIS	—	Changing the language setting can be performed.
	UNIT	US/METRIC	—	Changing the unit setting can be performed.
	METER EFFECT	ON/OFF	—	Changing the meter effect setting can be performed.

*: Press and hold the switch (1 second or more).

METER SYSTEM

< SYSTEM DESCRIPTION >

INFORMATION DISPLAY : Component Parts Location

INFOID:0000000110577027

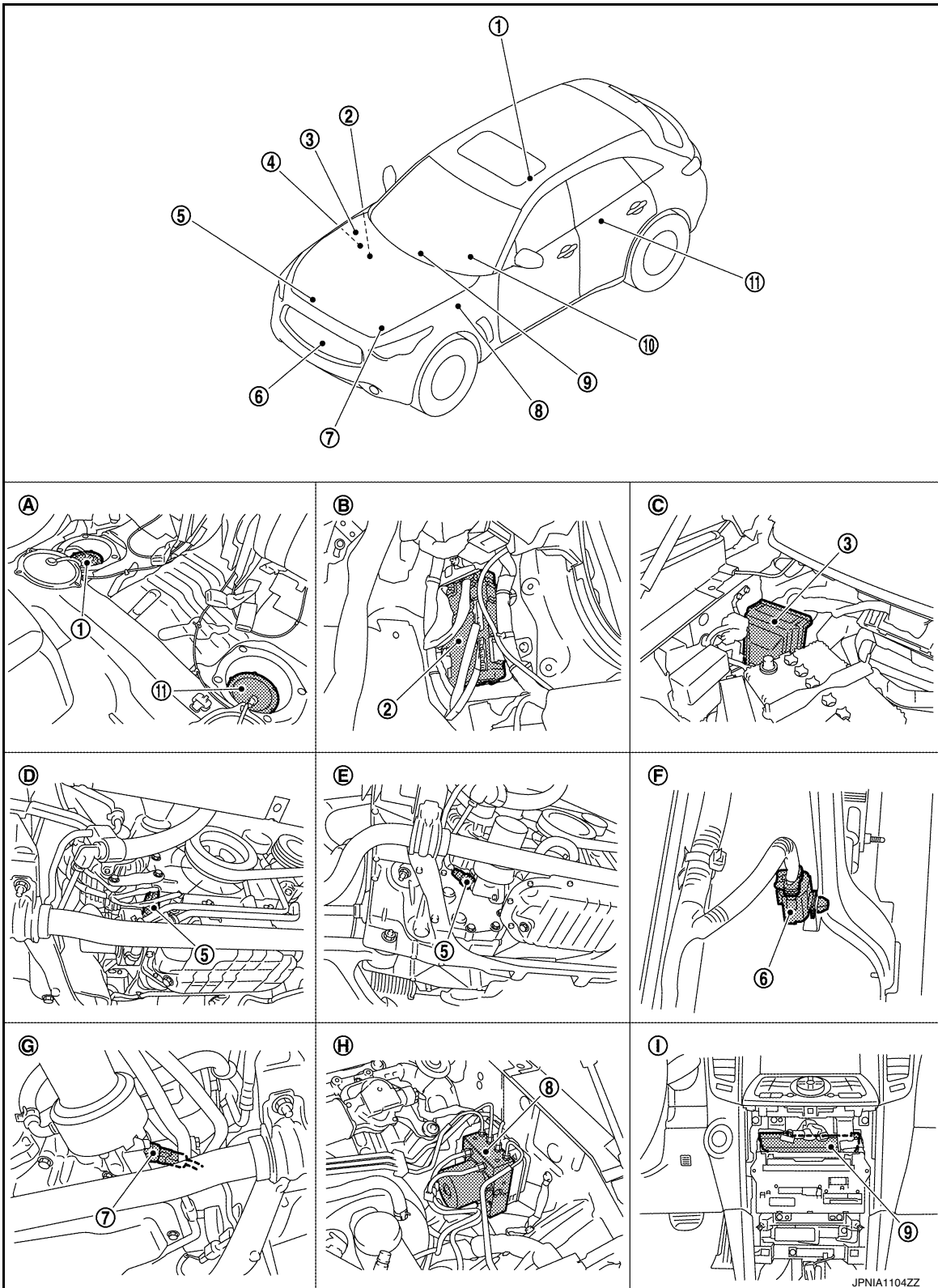

A
B
C
D
E
F
G
H
I
J
K
L
M
MWI
O
P

METER SYSTEM

< SYSTEM DESCRIPTION >

- | | | |
|--|--|-------------------------------|
| 1. Fuel level sensor unit and fuel pump (main) | 2. BCM | 3. IPDM E/R |
| 4. ECM : EC-51, "Component Parts Location" (VQ37VHR for USA and Canada)
ECM : EC-654, "Component Parts Location" (VQ37VHR for Mexico)
ECM : EC-1149, "Component Parts Location" (VK50VE engine models) | 5. Oil pressure switch (VQ37VHR engine models) | 6. Ambient sensor |
| 7. Oil pressure switch (VK50VE engine models) | 8. ABS actuator and electric unit (control unit) | 9. Unified meter and A/C amp. |
| 10. Combination meter | 11. Fuel level sensor unit (sub) | |
| A. Rear seat (bottom) | B. Dash side finisher (passenger side) | C. Hoodledge cover (RH) |
| D. 2WD [oil pan (upper) RH side] | E. AWD [oil filter bracket part (VQ37VHR engine models)] | F. Condenser (front) |
| G. AWD [oil filter bracket part (VK50VE engine models)] | H. Hoodledge cover (LH) | I. Behind cluster lid C |

INFORMATION DISPLAY : Component Description

INFOID:0000000010577028

Unit	Description
Combination meter	Controls the information display with the signals received from the unified meter and A/C amp. by means of communication and the signals from various switches and sensors.
Unified meter and A/C amp.	Transmits signals received from various units to the combination meter by means of communication.
Fuel level sensor unit	Refer to MWI-61, "Description" .
ECM	Transmits the following signals to the unified meter and A/C amp. via CAN communication. <ul style="list-style-type: none"> • Engine speed signal • Fuel consumption monitor signal • Fuel filler cap warning display signal
ABS actuator and electric unit (control unit)	Transmits the vehicle speed signal to the unified meter and A/C amp. via CAN communication.
BCM	Transmits signals provided by various units to the unified meter and A/C amp. via CAN communication.
Meter control switch	Transmits the following signals to the combination meter. <ul style="list-style-type: none"> • Enter switch signal • Select switch signal
Washer level switch	Transmits the washer level signal to the combination meter.
Parking brake switch	Refer to MWI-70, "Description" .
Door switch	Transmits the door switch signals to BCM.
Ambient sensor	Detects the ambient air temperature and transmits the ambient sensor signal to the unified meter and A/C amp.

COMPASS

< SYSTEM DESCRIPTION >

COMPASS

Description

INFOID:000000010577029

DESCRIPTION

- This electronic compass is able to display 8 primary directions: N, NE, E, SE, S, SW, W, NW.
- The compass switch (1) is used to operate the compass.

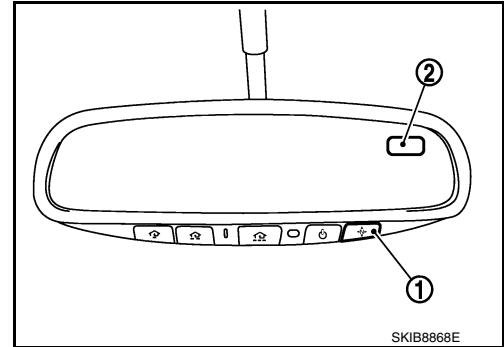

Switch Operation

Press	Compass is turned ON/OFF
Press and hold (for 3- 9 sec.)	Compass display (2) turns to zone variation change mode Compass
Press and hold (for more than 9 sec.)	Compass display turns to calibration mode

- All standard compasses determine direction relative to magnetic north; however, this electronic compass is designed to display direction relative to true north.
- The difference between magnetic north and true north varies from place to place across the surface of the earth.
- This electronic compass must be “told” approximately where it is on the earth’s surface so that the magnetic north reading can be properly converted into a true north display.
- To tell the electronic compass where it’s at, the earth is separated into numbered “zone variances”. The zone variance number in which the compass is to function must be entered into this electronic compass.
- Each zone is magnetically about 4.2° wide. Typically, anything under 22.5° total zone change is not noticed on the electronic compass display. However, over 22.5°, a reading may be off by one or more primary directions.
- On long trips, a vehicle may leave its original zone and enter one or more new zones. Generally, you do not need to reset the compass zone if you travel between 3 or 4 zones, such as business travel or vacation. The typical driver will not notice any difference on the display within 3 or 4 zones. However, if the vehicle is “permanently” moved to a new location, it is recommended that the compass zone be reset.

ZONE VARIATION SETTING PROCEDURE

A
B
C
D
E
F
G
H
I
J
K
L
M
O
P

MWI

COMPASS

< SYSTEM DESCRIPTION >

1. Press and hold the compass switch for 3 – 9 seconds.
2. The current zone setting appears on the compass display.
3. Find the current geographical location number in the zone variation chart.
4. Select the new zone number. (Press the compass switch until the new zone number appears on the compass display.)
5. After select the new zone number, the compass display will automatically shows a direction within a few seconds.
6. Perform the following calibration procedure for more accurate indications.

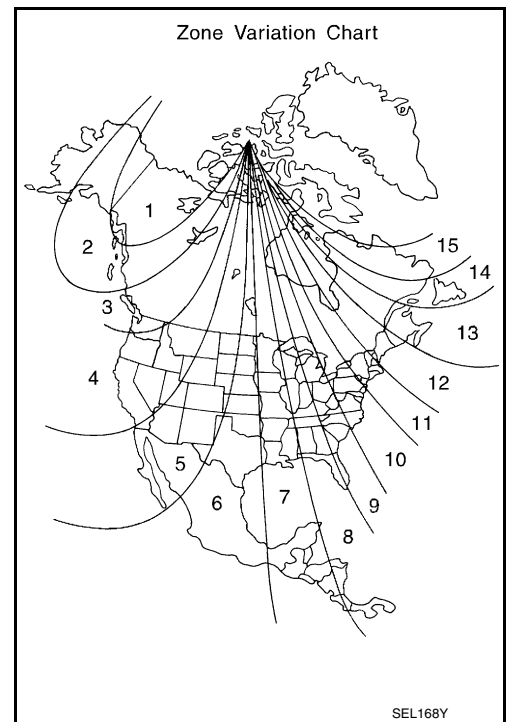

CALIBRATION PROCEDURE

NOTE:

The compass calibrates itself under normal driving conditions. However, occasional circumstances may cause the compass to operate inaccurately. Example: Driving from rural (wide open) areas to crowded city areas, or if an aftermarket (i.e., non original equipment) antenna with a magnetic base is attached to the vehicle. Calibrate the mirror compass if the display shows only one direction or a limited number of directions.

NOTE:

- If “magnetic hats” are used in the dealership for vehicle identification, remove the hat from the vehicle before performing the following steps. Do not put the hat back on the vehicle after the procedure is completed.
- Drive the vehicle to an open level area; away from large metallic objects, structures, and overhead power lines.
- Turn off “non-essential” electrical accessories (rear window defrost, heater/air conditioning, wipers) and close the doors.

1. Verify the correct compass zone setting for the geographical location.
2. Press and hold the compass switch for more than 9 seconds.
3. “C” is displayed on the compass display, when calibration starts.
4. Drive slowly [less than 8 km/h (5 MPH)] in a circle until the “C / CAL” is replaced with primary headings (N, NE, E, SE, S, SW, W, or NW).

NOTE:

This will require driving at least 2 complete 360 degree circles; 3 complete circles may be required.

5. The compass calibration procedure is now complete. The compass should operate normally.

NOTE:

If at any time the compass continually displays the incorrect direction or the reading is erratic or locked, repeat the calibration procedure.

COMPASS

< SYSTEM DESCRIPTION >

Component Parts Location

INFOID:000000010577030

- 1 : Compass switch
- 2 : Compass display

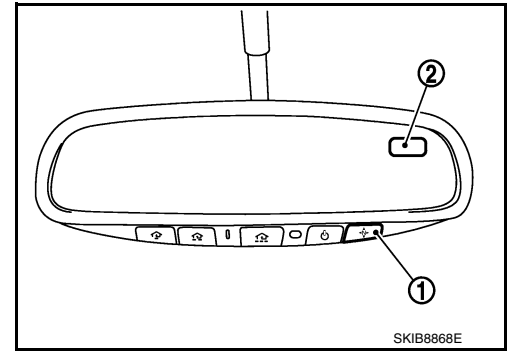

Special Repair Requirement

INFOID:000000010577031

1.PERFORM ZONE VARIATION SETTING

Perform the zone variation setting. Refer to [MWI-39, "Description"](#).

>> GO TO 2.

2.PERFORM CALIBRATION

Perform the calibration. Refer to [MWI-39, "Description"](#).

>> Setting completion

A
B
C
D
E
F
G
H
I
J
K
L
M
O
P

MWI

CLOCK

< SYSTEM DESCRIPTION >

CLOCK

Component Parts Location

INFOID:000000010577032

1 : Clock

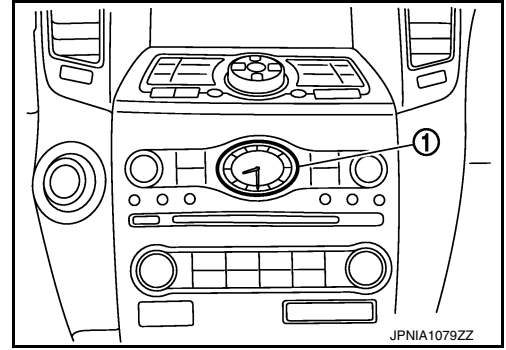

DIAGNOSIS SYSTEM (METER)

< SYSTEM DESCRIPTION >

DIAGNOSIS SYSTEM (METER)

Diagnosis Description

INFOID:000000010577033

SELF-DIAGNOSIS MODE

- Information display LCD segment operation can be checked in self-diagnosis mode.
- Meters/gauges can be checked in self-diagnosis mode.

OPERATION PROCEDURE

1. Turn ignition switch ON, and switch the trip meter to "trip A" or "trip B".

NOTE:

If the diagnosis function is activated with "trip A" displayed, the mileage on "trip A" is reset to "0000.0". (The same way for "trip B".)

2. Turn ignition switch OFF.
3. While pressing the trip A/B reset switch (1), turn ignition switch ON again.
4. Make sure that the trip meter displays "0000.0".
5. Press the trip A/B reset switch at least 3 times. (Within 7 seconds after the ignition switch is turned ON.)

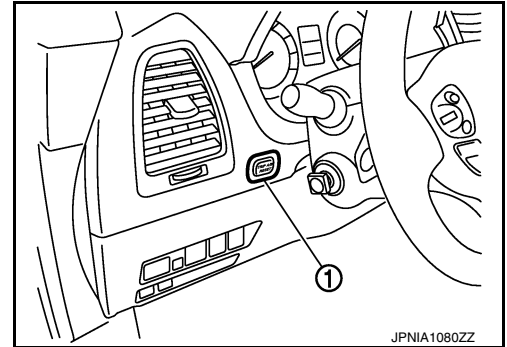

6. The unified meter control unit is turned to self-diagnosis mode.
 - Displays "888888" (1) and "8888.8" (2) in the information display LCD (3) for approximately 5 seconds and then blinks the segment dots of the information display LCD alternately.
 - Engine coolant temperature gauge and fuel gauge return to zero, and at the same time.

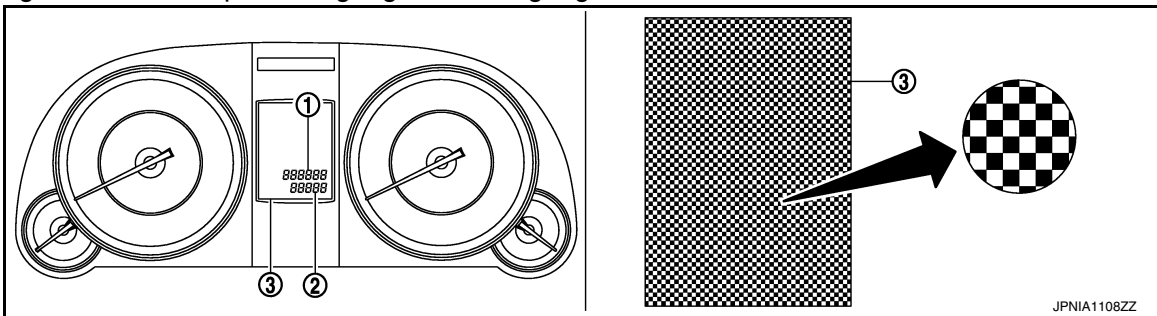

NOTE:

- Check combination meter power supply and ground circuit when self-diagnosis mode of combination meter does not start. Replace combination meter if normal.
- If any of the segments is not displayed, replace combination meter.

A
B
C
D
E
F
G
H
I
J
K
L
M
N
O
P

MWI

DIAGNOSIS SYSTEM (METER)

< SYSTEM DESCRIPTION >

7. Each meter activates during pressing trip A/B reset switch.

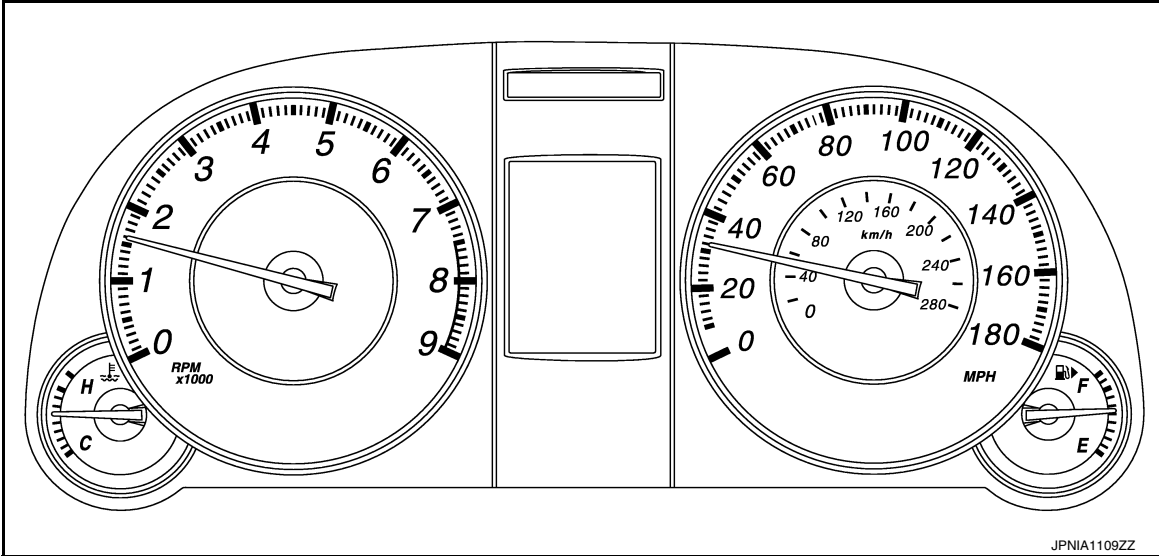

NOTE:

If any of the meter and gages is not activated, replace combination meter.

DIAGNOSIS SYSTEM (UNIFIED METER AND A/C AMP.)

< SYSTEM DESCRIPTION >

DIAGNOSIS SYSTEM (UNIFIED METER AND A/C AMP.)

CONSULT Function (METER/M&A)

INFOID:000000010577034

CONSULT APPLICATION ITEMS

CONSULT can perform the following diagnosis modes with CAN communication with the unified meter and A/C amp.

System	Diagnosis mode	Description
METER/M&A	Self Diagnostic Result	Unified meter and A/C amp. checks the conditions and displays memorized error.
	Data Monitor	Displays unified meter and A/C amp. input/output data in real time.
	Ecu Identification	The unified meter and A/C amp. part number is displayed.

SELF DIAG RESULT

Refer to [MWI-117, "DTC Index"](#).

DATA MONITOR

NOTE:

The following table includes information (items) inapplicable to this vehicle. For information (items) applicable to this vehicle, refer to CONSULT display items.

Display Item List

X: Applicable

Display item [Unit]	MAIN SIGNALS	Description
SPEED METER [km/h] or [mph]	X	Value of vehicle speed signal received from ABS actuator and electric unit (control unit) with CAN communication line. NOTE: 655.35 is displayed when the malfunction signal is received.
SPEED OUTPUT [km/h] or [mph]	X	Vehicle speed signal value transmitted to other units with CAN communication line. NOTE: 655.35 is displayed when the malfunction signal is received.
ODO OUTPUT [km/h]		Odometer signal value transmitted to other units with CAN communication line.
TACHO METER [rpm]	X	Value of the engine speed signal received from ECM with CAN communication line. NOTE: 8191.875 is displayed when the malfunction signal is received.
FUEL METER [L]	X	Fuel level indicated on combination meter.
W TEMP METER [°C] or [°F]	X	Value of engine coolant temperature signal received from ECM with CAN communication line. NOTE: 215 is displayed when the malfunction signal is input.
FUEL CAP W/L [On/Off]		Status of fuel filler cap warning display detected from fuel filler cap warning display signal received from ECM via CAN communication.
ABS W/L [On/Off]		Status of ABS warning lamp judged from ABS warning lamp signal received from ABS actuator and electric unit (control unit) with CAN communication line.
VDC/TCS IND [On/Off]		Status of VDC OFF indicator lamp judged from VDC OFF indicator lamp signal received from ABS actuator and electric unit (control unit) with CAN communication line.
SLIP IND [On/Off]		Status of VDC warning lamp judged from VDC warning lamp signal received from ABS actuator and electric unit (control unit) with CAN communication line.

DIAGNOSIS SYSTEM (UNIFIED METER AND A/C AMP.)

< SYSTEM DESCRIPTION >

Display item [Unit]	MAIN SIGNALS	Description
BRAKE W/L [On/Off]		Status of brake warning lamp judged from brake warning lamp signal received from ABS actuator and electric unit (control unit) with CAN communication line. NOTE: Displays "Off" if the brake warning lamp is illuminated when the valve check starts, the parking brake switch is turned ON or the brake fluid level switch is turned ON.
DOOR W/L [On/Off]		Status of door warning judged from door switch signal received from BCM with CAN communication line.
HI-BEAM IND [On/Off]		Status of high beam indicator lamp judged from high beam request signal received from BCM with CAN communication line.
TURN IND [On/Off]		Status of turn indicator lamp judged from turn indicator signal received from BCM with CAN communication line.
FR FOG IND [On/Off]		Status of front fog indicator lamp judged from front fog light request signal received from BCM with CAN communication line.
RR FOG IND [Off]		This item is displayed, but cannot be monitored.
LIGHT IND [On/Off]		Status of tail lamp indicator lamp judged from position light request signal received from BCM with CAN communication line.
OIL W/L [On/Off]		Status of oil pressure warning lamp judged from oil pressure switch signal received from IPDM E/R with CAN communication line.
MIL [On/Off]		Status of malfunction indicator lamp judged from malfunctioning indicator lamp signal received from ECM with CAN communication line.
GLOW IND [Off]		This item is displayed, but cannot be monitored.
C-ENG2 W/L [Off]		This item is displayed, but cannot be monitored.
CRUISE IND [On/Off]		<ul style="list-style-type: none"> • Status of CRUISE indicator judged from ASCD status signal received from ECM with CAN communication line. • Status of CRUISE indicator judged from meter display signal received from ICC sensor integrated unit with CAN communication line.
SET IND [On/Off]		<ul style="list-style-type: none"> • Status of SET indicator judged from ASCD status signal received from ECM with CAN communication line. • Status of SET indicator judged from meter display signal received from ICC sensor integrated unit with CAN communication line.
CRUISE W/L [On/Off]		Status of CRUISE warning lamp judged from ICC warning lamp signal received from ICC sensor integrated unit with CAN communication line.
BA W/L [On/Off]		Status of IBA OFF indicator lamp judged from IBA OFF indicator signal received from ICC sensor integrated unit with CAN communication line.
ATC/T-AMT W/L [On/Off]		Status of A/T check warning lamp judged from A/T check indicator lamp signal received from TCM with CAN communication line.
4WD W/L [On/Off]		Status of AWD warning lamp judged from AWD warning lamp signal received from AWD control unit with CAN communication line.
4WD LOCK IND [Off]		This item is displayed, but cannot be monitored.
FUEL W/L [On/Off]		Low-fuel warning status judged by the identified fuel level.
WASHER W/L [On/Off]		Status of washer warning judged from washer level switch input to combination meter.
AIR PRES W/L [On/Off]		Status of low tire pressure warning lamp judged from TPMS malfunction warning lamp signal received from BCM with CAN communication line.
KEY G/Y W/L [On/Off]		Status of key warning lamp (G/Y) judged from key warning signal received from BCM with CAN communication line.
AFS OFF IND [On/Off]		Status of AFS OFF indicator lamp judged from AFS OFF indicator lamp signal received from AFS control unit with CAN communication line.

DIAGNOSIS SYSTEM (UNIFIED METER AND A/C AMP.)

< SYSTEM DESCRIPTION >

Display item [Unit]	MAIN SIGNALS	Description	
4WAS/RAS W/L [On/Off]		This item is displayed, but cannot be monitored.	A
DDS* W/L [Off]		This item is displayed, but cannot be monitored.	B
LANE W/L [On/Off]		Status of lane departure warning lamp judged from lane departure warning lamp signal received from lane camera unit with CAN communication line.	C
LDP IND [On/Off]		Status of LDP ON indicator lamp judged from LDP ON indicator lamp signal received from lane camera unit with CAN communication line.	D
E-SUS IND [On/Off]		This item is displayed, but cannot be monitored.	E
DCA IND [On/Off]		Status of DCA switch indicator judged from meter display signal received from ICC sensor integrated unit with CAN communication line.	E
LCD [B&P N, B&P I, ID NG, ROTAT, SFT P, INSRT, BATT, NO KY,OUTKY, LK WN]		Displays status of Intelligent Key system warning judged from meter display signal received from BCM with CAN communication line.	F
ACC TARGET [On/Off]		Status of vehicle ahead detection indicator judged from meter display signal received from ICC sensor integrated unit with CAN communication line.	G
ACC DISTANCE [Off, SHOR, MID, LONG]		Status of set distance indicator judged from meter display signal received from ICC sensor integrated unit with CAN communication line.	G
ACC OWN VHL [On/Off]		Status of own vehicle indicator judged from meter display signal received from ICC sensor integrated unit with CAN communication line.	H
ACC SET SPEED		Status of set vehicle speed indicator judged from meter display signal received from ICC sensor integrated unit with CAN communication line.	I
ACC UNIT [On/Off]		Status of display unit judged from meter display signal received from ICC sensor integrated unit with CAN communication line.	I
SHIFT IND [P, R, N, D, L, M1, M2, M3, M4, M5, M6, M7]		Status of shift position indicator judged from shift position signal and manual mode indicator signal received from TCM with CAN communication line.	J
O/D OFF SW [Off]		This item is displayed, but cannot be monitored.	K
AT S MODE SW [On/Off]		Status of snow mode switch.	K
AT P MODE SW [Off]		This item is displayed, but cannot be monitored.	L
M RANGE SW [On/Off]		Status of manual mode switch.	M
NM RANGE SW [On/Off]		Status of non-manual mode switch.	M
AT SFT UP SW [On/Off]		Status of A/T shift up switch.	MWI
AT SFT DWN SW [On/Off]		Status of A/T shift down switch.	O
ST SFT UP SW [On/Off]		Status of paddle shifter up switch.	O
ST SFT DWN SW [On/Off]		Status of paddle shifter down switch.	P
COMP F/B SIG [On/Off]		A/C compressor activation condition that ECM judges according to the water temperature and the acceleration degree.	
4WD LOCK SW [Off]		This item is displayed, but cannot be monitored.	
PKB SW [On/Off]		Status of parking brake switch.	

DIAGNOSIS SYSTEM (UNIFIED METER AND A/C AMP.)

< SYSTEM DESCRIPTION >

Display item [Unit]	MAIN SIGNALS	Description
BUCKLE SW [On/Off]		Status of seat belt buckle switch.
BRAKE OIL SW [On/Off]		Status of brake fluid level switch.
DISTANCE [km/h]		Value of possible driving distance calculated by unified meter and A/C amp.
OUTSIDE TEMP [°C] or [°F]		Ambient air temperature value converted from ambient sensor signal received from ambient sensor. NOTE: This may not match with the temperature value indicated on the information display. (Because the information display value is a corrected value from the ambient sensor input value.)
FUEL LOW SIG [On/Off]		Status of fuel level low warning signal to output to AV control unit with CAN communication line.
BUZZER [On/Off]	X	Buzzer status (in the combination meter) is judged with the buzzer output signal received from each unit with CAN communication line and the warning output condition of the combination meter.

*: DDS (hill descent control)

U1000 CAN COMM CIRCUIT

< DTC/CIRCUIT DIAGNOSIS >

DTC/CIRCUIT DIAGNOSIS

U1000 CAN COMM CIRCUIT

Description

INFOID:0000000010577035

CAN (Controller Area Network) is a serial communication line for real time application. It is an on-vehicle multiplex communication line with high data communication speed and excellent error detection ability. Many electronic control units are equipped onto a vehicle, and each control unit shares information and links with other control units during operation (not independent). In CAN communication, control units are connected with two communication lines (CAN-H line, CAN-L line) allowing a high rate of information transmission with less wiring. Each control unit transmits/receives data but selectively reads required data only.

CAN Communication Signal Chart. Refer to [LAN-24, "How to Use CAN Communication Signal Chart"](#).

DTC Logic

INFOID:0000000010577036

DTC DETECTION LOGIC

DTC	Display contents of CONSULT	Diagnostic item is detected when ...	Probable malfunction location
U1000	CAN COMM CIRCUIT	When unified meter and A/C amp. is not transmitting or receiving CAN communication signal for 2 seconds or more.	CAN communication system

Diagnosis Procedure

INFOID:0000000010577037

1.PERFORM SELF DIAGNOSTIC

1. Turn ignition switch ON and wait for 2 seconds or more.
2. Check "Self Diagnostic Result" of "METER/M&A".

Is "CAN COMM CIRCUIT" displayed?

- YES >> Refer to [LAN-25, "Trouble Diagnosis Flow Chart"](#).
NO >> Refer to [GI-47, "Intermittent Incident"](#).

U1010 CONTROL UNIT (CAN)

< DTC/CIRCUIT DIAGNOSIS >

U1010 CONTROL UNIT (CAN)

Description

INFOID:000000010577038

Initial diagnosis of unified meter and A/C amp.

DTC Logic

INFOID:000000010577039

DTC DETECTION LOGIC

DTC	Display contents of CONSULT	Diagnostic item is detected when ...	Probable malfunction location
U1010	CONTROL UNIT (CAN)	If any malfunction is detected during initial diagnosis of unified meter and A/C amp. CAN controller	Unified meter and A/C amp.

Diagnosis Procedure

INFOID:000000010577040

1. REPLACE UNIFIED METER AND A/C AMP.

When DTC "U1010" is detected, replace unified meter and A/C amp.

>> INSPECTION END

B2201 COMMUNICATION ERROR 1

< DTC/CIRCUIT DIAGNOSIS >

B2201 COMMUNICATION ERROR 1

Description

INFOID:000000010577041

The communication line (LCD <-> AMP.) is used to communicate signals between the combination meter and the unified meter and A/C amp. in order to control the information display.

DTC Logic

INFOID:000000010577042

DTC DETECTION LOGIC

DTC	Display contents of CONSULT	Diagnostic item is detected when ...	Probable malfunction location
B2201	COMM ERROR 1	If a communication error is present in the communication line (LCD <-> AMP.) for 2 seconds or more	Communication line (LCD <-> AMP.) circuit

Diagnosis Procedure

INFOID:000000010577043

1. CHECK CONNECTOR

Check combination meter, unified meter and A/C amp. and terminals (combination meter side, unified meter and A/C amp. side, and harness side) for looseness or bent.

Is the inspection result normal?

YES >> GO TO 2.

NO >> Repair terminal or connector.

2. CHECK CONTINUITY COMMUNICATION CIRCUIT

1. Turn ignition switch OFF.
2. Disconnect combination meter connector and unified meter and A/C amp. connector.
3. Check continuity between combination meter harness connector and unified meter and A/C amp. harness connector.

Combination meter		Unified meter and A/C amp.		Continuity
Connector	Terminal	Connector	Terminal	
M53	24	M66	14	Existed
	25		34	Existed

4. Check continuity between combination meter harness connector and ground.

Combination meter		Ground	Continuity
Connector	Terminal		
M53	24		Not existed
	25		Not existed

Is the inspection result normal?

YES >> GO TO 3.

NO >> Repair harness or connector.

3. CHECK UNIFIED METER AND A/C AMP. OUTPUT VOLTAGE

1. Connect unified meter and A/C amp. connector.
2. Turn ignition switch ON.
3. Check voltage between unified meter and A/C amp. harness connector and ground.

A
B
C
D
E
F
G
H
I
J
K
L
M
N
O
P

MWI

B2201 COMMUNICATION ERROR 1

< DTC/CIRCUIT DIAGNOSIS >

Terminals		Voltage (Approx.)
(+)	(-)	
Unified meter A/C amp.		12 V
Connector	Terminal	
M66	14	
		Ground

Is the inspection result normal?

YES >> GO TO 4.

NO >> Replace unified meter and A/C amp.

4. CHECK COMBINATION METER OUTPUT VOLTAGE

1. Turn ignition switch OFF.
2. Disconnect unified meter and A/C amp. connector.
3. Connect combination meter connector.
4. Turn ignition switch ON.
5. Check voltage between combination meter harness connector and ground.

Terminal		Voltage (Approx.)
(+)	(-)	
Combination meter		5 V
Connector	Terminal	
M53	25	
		Ground

Is the inspection result normal?

YES >> INSPECTION END

NO >> Replace combination meter.

B2202 COMMUNICATION ERROR 2

< DTC/CIRCUIT DIAGNOSIS >

B2202 COMMUNICATION ERROR 2

Description

INFOID:000000010577044

The communication line (METER <-> AMP.) is used to communicate signals between the combination meter and the unified meter and A/C amp. in order to control the combination meter.

DTC Logic

INFOID:000000010577045

DTC DETECTION LOGIC

DTC	Display contents of CONSULT	Diagnostic item is detected when ...	Probable malfunction location
B2202	COMM ERROR 2	If a communication error is present in the communication line (METER <-> AMP.) for 2 seconds or more	Communication line (METER <-> AMP.) circuit

Diagnosis Procedure

INFOID:000000010577046

1.CHECK CONNECTOR

Check combination meter, unified meter and A/C amp. and terminals (combination meter side, unified meter and A/C amp. side, and harness side) for looseness or bent.

Is the inspection result normal?

YES >> GO TO 2.

NO >> Repair terminal or connector.

2.CHECK CONTINUITY COMMUNICATION CIRCUIT

1. Turn ignition switch OFF.
2. Disconnect combination meter connector and unified meter and A/C amp. connector.
3. Check continuity between combination meter harness connector and unified meter and A/C amp. harness connector.

Combination meter		Unified meter and A/C amp.		Continuity
Connector	Terminal	Connector	Terminal	
M53	2	M66	27	Existed
	3		7	Existed

4. Check continuity between combination meter harness connector and ground.

Combination meter		Ground	Continuity
Connector	Terminal		
M53	2		Not existed
	3		Not existed

Is the inspection result normal?

YES >> GO TO 3.

NO >> Repair harness or connector.

3.CHECK UNIFIED METER AND A/C AMP. OUTPUT VOLTAGE

1. Turn ignition switch OFF.
2. Disconnect combination meter connector.
3. Connect unified meter and A/C amp. connector.
4. Turn ignition switch ON.
5. Check voltage between unified meter and A/C amp. harness connector and ground.

A
B
C
D
E
F
G
H
I
J
K
L
M
N
O
P

MWI

B2202 COMMUNICATION ERROR 2

< DTC/CIRCUIT DIAGNOSIS >

Terminals		Voltage (Approx.)
(+)	(-)	
Unified meter A/C amp.		5 V
Connector	Terminal	
M66	27	

Is the inspection result normal?

YES >> GO TO 4.

NO >> Replace unified meter and A/C amp.

4. CHECK COMBINATION METER OUTPUT VOLTAGE

1. Turn ignition switch OFF.
2. Disconnect unified meter and A/C amp. connector.
3. Connect combination meter connector.
4. Turn ignition switch ON.
5. Check voltage between combination meter harness connector and ground.

Terminals		Voltage (Approx.)
(+)	(-)	
Combination meter		5 V
Connector	Terminal	
M53	3	

Is the inspection result normal?

YES >> INSPECTION END

NO >> Replace combination meter.

B2205 VEHICLE SPEED

< DTC/CIRCUIT DIAGNOSIS >

B2205 VEHICLE SPEED

Description

INFOID:000000010577047

Vehicle speed signal is transmitted from ABS actuator and electric unit (control unit) via CAN communication to unified meter and A/C amp.

DTC Logic

INFOID:000000010577048

DTC DETECTION LOGIC

DTC	Display contents of CONSULT	Diagnostic item is detected when ...	Probable malfunction location
B2205	VEHICLE SPEED	If the abnormal vehicle speed signal is input from ABS actuator and electric unit (control unit) for 2 seconds or more	<ul style="list-style-type: none">• Wheel sensor• ABS actuator and electric unit (control unit)

Diagnosis Procedure

INFOID:000000010577049

1.PERFORM SELF-DIAGNOSIS OF ABS ACTUATOR AND ELECTRIC UNIT (CONTROL UNIT)

Perform "Self Diagnostic Result" of ABS actuator and electric unit (control unit), and repair or replace malfunctioning parts.

>> Refer to [BRC-31, "CONSULT Function"](#).

A
B
C
D
E
F
G
H
I
J
K
L
M
O
P

MWI

B2267 ENGINE SPEED

< DTC/CIRCUIT DIAGNOSIS >

B2267 ENGINE SPEED

Description

INFOID:000000010577050

The engine speed signal is transmitted from ECM to the unified meter and A/C amp. with CAN communication.

DTC Logic

INFOID:000000010577051

DTC DETECTION LOGIC

DTC	Display contents of CONSULT	Diagnostic item is detected when ...	Probable malfunction location
B2267	ENGINE SPEED	If ECM continuously transmits abnormal engine speed signals for 2 seconds or more	<ul style="list-style-type: none">• Crankshaft position sensor (POS)• ECM

Diagnosis Procedure

INFOID:000000010577052

1. PERFORM SELF-DIAGNOSIS OF ECM

Perform "Self Diagnostic Result" of ECM, and repair or replace malfunctioning parts.

- >> • [EC-157, "CONSULT Function"](#) (VQ37VHR for USA and Canada)
- [EC-750, "CONSULT Function"](#) (VQ37VHR for Mexico)
- [EC-1264, "CONSULT Function"](#) (VK50VE models)

B2268 WATER TEMP

< DTC/CIRCUIT DIAGNOSIS >

B2268 WATER TEMP

Description

INFOID:000000010577053

The engine coolant temperature signal is transmitted from ECM to the unified meter and A/C amp. via CAN communication.

DTC Logic

INFOID:000000010577054

DTC DETECTION LOGIC

DTC	Display contents of CONSULT	Diagnostic item is detected when ...	Probable malfunction location
B2268	WATER TEMP	If ECM continuously transmits abnormal engine coolant temperature signals for 60 seconds or more	<ul style="list-style-type: none">• Engine coolant temperature sensor• ECM

Diagnosis Procedure

INFOID:000000010577055

1. PERFORM SELF-DIAGNOSIS OF ECM

Perform "Self Diagnosis Result" of ECM, and repair or replace malfunctioning parts.

- >> • [EC-157. "CONSULT Function"](#) (VQ37VHR for USA and Canada)
- [EC-750. "CONSULT Function"](#) (VQ37VHR for Mexico)
- [EC-1264. "CONSULT Function"](#) (VK50VE models)

A
B
C
D
E
F
G
H
I
J
K
L
M
O
P

MWI

POWER SUPPLY AND GROUND CIRCUIT

< DTC/CIRCUIT DIAGNOSIS >

POWER SUPPLY AND GROUND CIRCUIT COMBINATION METER

COMBINATION METER : Diagnosis Procedure

INFOID:0000000010577056

1.CHECK FUSE

Check for blown fuses.

Power source	Fuse No.
Battery	6
Ignition switch ON or START	4

Is the inspection result normal?

YES >> GO TO 2.

NO >> Be sure to eliminate cause of malfunction before installing new fuse.

2.CHECK POWER SUPPLY CIRCUIT

Check voltage between combination meter harness connector and ground.

Terminals			Ignition switch position	Value (Approx.)
(+)		(-)		
Combination meter	Terminal	Signal name		
M53	1	Battery power supply	OFF	Battery voltage
	21	Ignition signal	ON	Battery voltage

Is the inspection result normal?

YES >> GO TO 3.

NO >> Check harness between combination meter and fuse.

3.CHECK GROUND CIRCUIT

1. Turn ignition switch OFF.
2. Disconnect combination meter connector.
3. Check continuity between combination meter harness connector and ground.

Combination meter		Ground	Continuity
Connector	Terminal		
M53	5		Existed
	15		Existed

Is the inspection result normal?

YES >> INSPECTION END

NO >> Repair harness or connector.

UNIFIED METER AND A/C AMP.

UNIFIED METER AND A/C AMP. : Diagnosis Procedure

INFOID:0000000010577057

1.CHECK FUSE

Check for blown fuses.

Power source	Fuse No.
Battery	6
Ignition switch ACC or ON	19
Ignition switch ON or START	3

Is the inspection result normal?

POWER SUPPLY AND GROUND CIRCUIT

< DTC/CIRCUIT DIAGNOSIS >

YES >> GO TO 2.

NO >> Be sure to eliminate cause of malfunction before installing new fuse.

2.CHECK POWER SUPPLY CIRCUIT

Check voltage between unified meter and A/C amp. harness connector and ground.

Terminals			Ignition switch position	Value (Approx.)
(+)		(-)		
Unified meter A/C amp.	Terminal		Signal name	
M67	54	Battery power supply	OFF	Battery voltage
	41	ACC power supply	ACC	Battery voltage
	53	Ignition power supply	ON	Battery voltage

Is the inspection result normal?

YES >> GO TO 3.

NO >> Check harness between unified meter and A/C amp. and fuse.

3.CHECK GROUND CIRCUIT

1. Turn ignition switch OFF.
2. Disconnect unified meter and A/C amp. connector.
3. Check continuity between unified meter and A/C amp. harness connector and ground.

Unified meter A/C amp.		Ground	Continuity
Connector	Terminal		
M67	55		Existed
	71		Existed

Is the inspection result normal?

YES >> INSPECTION END

NO >> Repair harness or connector.

IPDM E/R (INTELLIGENT POWER DISTRIBUTION MODULE ENGINE ROOM)

IPDM E/R (INTELLIGENT POWER DISTRIBUTION MODULE ENGINE ROOM) : Diagnosis Procedure

INFOID:0000000011008573

1.CHECK FUSES AND FUSIBLE LINK

Check that the following IPDM E/R fuses or fusible links are not blown.

Signal name	Fuses and fusible link No.
Battery power supply	D
	50
	51

Is the fuse fusing?

YES >> Replace the blown fuse or fusible link after repairing the affected circuit if a fuse or fusible link is blown.

NO >> GO TO 2.

2.CHECK POWER SUPPLY CIRCUIT

1. Turn the ignition switch OFF.
2. Disconnect IPDM E/R connector.
3. Check voltage between IPDM E/R harness connector and ground.

POWER SUPPLY AND GROUND CIRCUIT

< DTC/CIRCUIT DIAGNOSIS >

Terminals		Voltage (Approx.)
(+)	(-)	
IPDM E/R		Ground
Connector	Terminal	
E4	1	Battery voltage

Is the measurement value normal?

YES >> GO TO 3.

NO >> Repair harness or connector.

3.CHECK GROUND CIRCUIT

Check continuity between IPDM E/R harness connectors and ground.

IPDM E/R		Ground	Continuity
Connector	Terminal		
E5	12		Existed
E6	41		

Does continuity exist?

YES >> INSPECTION END

NO >> Repair harness or connector.

FUEL LEVEL SENSOR SIGNAL CIRCUIT

< DTC/CIRCUIT DIAGNOSIS >

FUEL LEVEL SENSOR SIGNAL CIRCUIT

Description

INFOID:000000010577059

The fuel level sensor unit and fuel pump (main) and the fuel level sensor unit (sub) detect the fuel level in the fuel tank and transmit the fuel gauge signal to the unified meter and A/C amp.

Component Function Check

INFOID:000000010577060

1. PERFORM SELF-DIAGNOSIS OF UNIFIED METER AND A/C AMP.

Perform "Self Diagnosis" of unified meter and A/C amp. with CONSULT.

Is any DTC detected?

YES >> Perform diagnosis on the detected DTC and repair or replace the malfunctioning parts. Refer to [MWI-117, "DTC Index"](#).

NO >> GO TO 2.

2. PERFORM COMPONENT FUNCTION CHECK (1)

1. Turn ignition switch OFF.
2. Disconnect fuel level sensor unit and fuel pump (main) connector and fuel level sensor unit (sub) connector.
3. Connect variable resistor between harness connector terminals located on the vehicle side of the fuel level sensor unit and fuel pump (main) and fuel level sensor unit (sub).

Fuel level sensor unit and fuel pump (main)		Fuel level sensor unit (sub)	
Connector	Terminal	Connector	Terminal
B22	5	B21	1

4. Set variable resistor according to the resistance value shown in the following table and turn ignition switch ON.

Resistance (Ω) (Approx.)	Fuel gauge indication position (Approx.)
Less than 6.0	Full
25.5	3/4
45.5	2/4
66.0	1/4
More than 80.0	Empty

*: Reference resistance values used when the combination meter judges the indication position of the fuel gauge.

Is the inspection result normal?

YES >> GO TO 3.

NO >> GO TO 4.

3. PERFORM COMPONENT FUNCTION CHECK (2)

Check the fuel level sensor unit and fuel pump (main) and/or fuel level sensor unit (sub). Refer to [MWI-63, "Component Inspection"](#).

Is the inspection result normal?

YES >> INSPECTION END

NO >> Replace fuel level sensor unit and fuel pump (main) and/or fuel level sensor unit (sub). Refer to [FL-6, "Removal and Installation"](#).

4. CHECK DATA MONITOR OF UNIFIED METER AND A/C AMP.

Select "FUEL METER" that is the data monitor item of "METER/M&A". Apply resistance according to the table below and check the monitor value.

A
B
C
D
E
F
G
H
I
J
K
L
M
N
O
P

MWI

FUEL LEVEL SENSOR SIGNAL CIRCUIT

< DTC/CIRCUIT DIAGNOSIS >

Resistance (Ω) (Approx.)	Reference value of data monitor [L] (Approx.)
Less than 6.0	82
25.5	68
45.5	47
66.0	23
More than 80.0	11

Is the inspection result normal?

- YES >> Replace combination meter. Refer to [MWI-143, "Removal and Installation"](#).
 NO >> Refer to [MWI-62, "Diagnosis Procedure"](#).

Diagnosis Procedure

INFOID:000000010577061

1. CHECK FUEL LEVEL SENSOR (SUB) CIRCUIT

- Turn ignition switch OFF.
- Disconnect unified meter and A/C amp. connector and fuel level sensor unit (sub) connector.
- Check continuity between unified meter and A/C amp. harness connector and fuel level sensor unit (sub) harness connector.

Unified meter A/C amp.		Fuel level sensor unit (sub)		Continuity
Connector	Terminal	Connector	terminal	
M67	42	B21	1	Existed

- Check continuity between unified meter and A/C amp. harness connector and ground.

Unified meter A/C amp.		Ground	Continuity
Connector	Terminal		
M67	42		Not existed

Is the inspection result normal?

- YES >> GO TO 2.
 NO >> Repair harness or connector.

2. CHECK FUEL LEVEL SENSOR (MAIN-SUB) CIRCUIT

- Disconnect fuel level sensor unit and fuel pump (main) connector.
- Check continuity between fuel level sensor unit (sub) harness connector and fuel level sensor unit and fuel pump (main) harness connector.

Fuel level sensor unit (sub)		Fuel level sensor unit and fuel pump (main)		Continuity
Connector	Terminal	Connector	terminal	
B21	2	B22	2	Existed

- Check continuity between fuel level sensor unit (sub) harness connector and ground.

Fuel level sensor unit (sub)		Ground	Continuity
Connector	Terminal		
B21	2		Not existed

Is the inspection result normal?

- YES >> GO TO 3.
 NO >> Repair harness or connector.

3. CHECK FUEL LEVEL SENSOR (MAIN) CIRCUIT

FUEL LEVEL SENSOR SIGNAL CIRCUIT

< DTC/CIRCUIT DIAGNOSIS >

Check continuity between fuel level sensor unit and fuel pump (main) harness connector and unified meter and A/C amp. harness connector.

Fuel level sensor unit and fuel pump (main)		Unified meter A/C amp.		Continuity
Connector	Terminal	Connector	terminal	
B22	5	M67	58	Existed

Is the inspection result normal?

- YES >> Replace unified meter and A/C amp. Refer to [MWI-144, "Removal and Installation"](#).
 NO >> Repair harness or connector.

Component Inspection

INFOID:0000000010577062

1. CHECK FUEL LEVEL SENSOR UNIT AND FUEL PUMP (MAIN)

- Remove fuel level sensor unit and fuel pump (main). Refer to [FL-6, "Removal and Installation"](#).
- Check the resistance between fuel level sensor unit and fuel pump (main).

Fuel level sensor unit and fuel pump (main)		Condition	Resistance (Approx.)
Terminal			
2	5	Full (A)	2.5 Ω
		Empty (B)	81.5 Ω

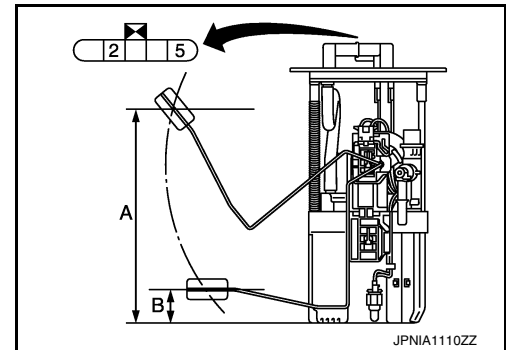

Standard float position

Standard float position [mm (in)]*	
Full (A)	Approx. 221.9 (8.74)
Empty (B)	Approx. 29.8 (1.173)

*: When float rod is contact with stopper.

Is the inspection result normal?

- YES >> GO TO 2.
 NO >> Replace fuel level sensor unit and fuel pump (main). Refer to [FL-6, "Removal and Installation"](#).

2. CHECK FUEL LEVEL SENSOR UNIT (SUB)

- Remove fuel level sensor unit (sub). Refer to [FL-6, "Removal and Installation"](#).
- Inspect the resistance of fuel level sensor unit (sub).

Fuel level sensor unit (sub)		Condition	Resistance (Approx.)
Terminal			
1	2	Full (A)	2.5 Ω
		Empty (B)	40.0 Ω

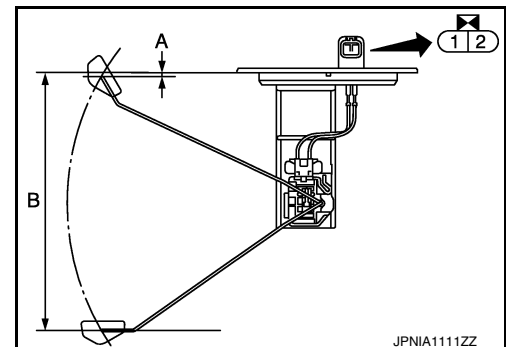

Standard float position

Standard float position [mm (in)]*	
Full (A)	Approx. 8.5 (0.335)
Empty (B)	Approx. 201.6 (7.94)

*: When float rod is contact with stopper.

Is the inspection result normal?

A
B
C
D
E
F
G
H
I
J
K
L
M
N
O
P

MWI

FUEL LEVEL SENSOR SIGNAL CIRCUIT

< DTC/CIRCUIT DIAGNOSIS >

YES >> INSPECTION END.

NO >> Replace fuel level sensor unit (sub). Refer to [FL-6, "Removal and Installation"](#).

METER CONTROL SWITCH SIGNAL CIRCUIT





< DTC/CIRCUIT DIAGNOSIS >

METER CONTROL SWITCH SIGNAL CIRCUIT

Description

INFOID:000000010577063

Transmits the following signals to the combination meter.





-  (illumination control) switch signal (+)
-  (illumination control) switch signal (-)
-  (select) switch signal
-  (enter) switch signal

Diagnosis Procedure

INFOID:000000010577064

1. CHECK METER CONTROL SWITCH INPUT SIGNAL

1. Turn the ignition switch ON.
2. Check voltage between the following terminals of the combination meter.

Combination meter		Condition	Voltage	
Connector	Terminal			
	(+)	(-)		
M53	36	16	When  (select) switch is pressed	0 V
			Other than the above	5 V
	37	16	When  (enter) switch is pressed	0 V
			Other than the above	5 V
	39	16	When  (illumination control) switch is pressed	0 V
			Other than the above	5 V
	40	16	When  (illumination control) switch is pressed	0 V
			Other than the above	5 V

Is the inspection result normal?

- YES >> INSPECTION END
 NO >> GO TO 2.

2. CHECK METER CONTROL SWITCH SIGNAL CIRCUIT

1. Turn the ignition switch OFF.
2. Disconnect the combination meter and meter control switch connectors.
3. Check continuity between combination meter harness connector and meter control switch harness connector.

Combination meter		Meter control switch		Continuity
Connector	Terminal	Connector	Terminal	
M53	16	M54	2	Existed
	36		6	Existed
	37		7	Existed
	39		3	Existed
	40		1	Existed

4. Check continuity between combination meter harness connector and ground.

A
B
C
D
E
F
G
H
I
J
K
L
M

MWI

O
P

METER CONTROL SWITCH SIGNAL CIRCUIT

< DTC/CIRCUIT DIAGNOSIS >

Combination meter		Ground	Continuity
Connector	Terminal		
M53	16	Ground	Not existed
	36		Not existed
	37		Not existed
	39		Not existed
	40		Not existed

Is the inspection result normal?

YES >> INSPECTION END

NO >> Repair harness or connector.

Component Inspection

INFOID:000000010577065

1. CHECK METER CONTROL SWITCH UNIT

1. Turn the ignition switch OFF.
2. Disconnect the meter control switch connector.
3. Check continuity between the following terminals of the meter control switch.

Combination meter			Operation and status	Continuity
Connector	Terminal			
M54	6	2	Press ● (select) switch	Existed
			Other than the above	Not existed
	7	2	Press □ (enter) switch	Existed
			Other than the above	Not existed
	3	2	Press ⚡- (illumination control) switch	Existed
			Other than the above	Not existed
	1	2	Press ⚡+ (illumination control) switch	Existed
			Other than the above	Not existed

Is the inspection result normal?

YES >> INSPECTION END

NO >> Replace the meter control switch.

TRIP A/B RESET SWITCH SIGNAL CIRCUIT

< DTC/CIRCUIT DIAGNOSIS >

TRIP A/B RESET SWITCH SIGNAL CIRCUIT

Description

INFOID:000000010577066

Transmits the trip A/B reset switch signals to the combination meter.

Diagnosis Procedure

INFOID:000000010577067

1. CHECK TRIP A/B RESET SWITCH INPUT SIGNAL

1. Turn the ignition switch ON.
2. Check voltage between the combination meter harness connector terminals.

Combination meter			Condition	Voltage
Connector	Terminal			
	(+)	(-)		
M53	38	16	When trip A/B reset switch is pressed	0 V
			Other than the above	5 V

Is the inspection result normal?

- YES >> INSPECTION END
NO >> GO TO 2.

2. CHECK TRIP A/B RESET SWITCH SIGNAL CIRCUIT

1. Turn the ignition switch OFF.
2. Disconnect the combination meter and meter control switch connectors.
3. Check continuity between combination meter harness connector and trip A/B reset switch harness connector.

Combination meter		Trip A/B reset switch		Continuity
Connector	Terminal	Connector	Terminal	
M53	38	M56	1	Existed
	16		2	Existed

4. Check continuity between combination meter harness connector and ground.

Combination meter		Ground	Continuity
Connector	Terminal		
M53	38		Not existed
	16	Not existed	

Is the inspection result normal?

- YES >> INSPECTION END
NO >> Repair harness or connector.

Component Inspection

INFOID:000000010577068

1. CHECK TRIP A/B RESET SWITCH UNIT

1. Turn the ignition switch OFF.
2. Disconnect the trip A/B reset switch connector.
3. Check continuity between the trip A/B reset switch connector terminals.

Combination meter			Operation and status	Continuity
Connector	Terminal			
M56	1	2	Press trip A/B reset switch	Existed
			Other than the above	Not existed

A
B
C
D
E
F
G
H
I
J
K
L
M
N
O
P

MWI

TRIP A/B RESET SWITCH SIGNAL CIRCUIT

< DTC/CIRCUIT DIAGNOSIS >

Is inspection result normal?

YES >> INSPECTION END

NO >> Replace the trip A/B reset switch.

OIL PRESSURE SWITCH SIGNAL CIRCUIT

< DTC/CIRCUIT DIAGNOSIS >

OIL PRESSURE SWITCH SIGNAL CIRCUIT

Description

INFOID:000000010577069

Detects the engine oil pressure and transmits the oil pressure switch signal to IPDM E/R.

Component Function Check

INFOID:000000010577070

1. CHECK UNIFIED METER AND A/C AMP. INPUT SIGNAL

Select the "Data Monitor" for the "METER/M&A" and check the "OIL W/L" monitor value.

"OIL W/L"
 Ignition switch ON : On
 Engine running : Off

>> INSPECTION END

Diagnosis Procedure

INFOID:000000010577071

1. CHECK OIL PRESSURE SWITCH CIRCUIT

1. Turn ignition switch OFF.
2. Disconnect IPDM E/R connector and oil pressure switch connector.
3. Check continuity between IPDM E/R harness connector and oil pressure switch harness connector.

IPDM E/R		Oil pressure switch		Continuity
Connector	Terminal	Connector	Terminal	
E7	75	F37	1	Existed

4. Check continuity between IPDM E/R harness connector and ground.

IPDM E/R		Ground	Continuity
Connector	Terminal		
E7	75		Not existed

Is the inspection result normal?

- YES >> INSPECTION END
 NO >> Repair harness or connector.

Component Inspection

INFOID:000000010577072

1. CHECK OIL PRESSURE SWITCH UNIT

Check continuity between oil pressure switch and ground.

Condition	Continuity
Engine stopped	Existed
Engine running	Not existed

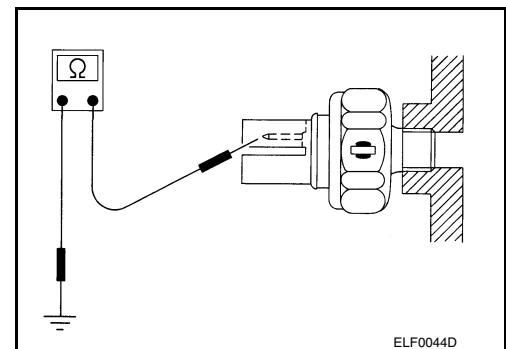

Is the inspection result normal?

- YES >> INSPECTION END
 NO >> Replace the oil pressure switch.

A
B
C
D
E
F
G
H
I
J
K
L
M
MWI
O
P

PARKING BRAKE SWITCH SIGNAL CIRCUIT

< DTC/CIRCUIT DIAGNOSIS >

PARKING BRAKE SWITCH SIGNAL CIRCUIT

Description

INFOID:000000010577073

Transmits the parking brake switch signal to the combination meter.

Diagnosis Procedure

INFOID:000000010577074

1. CHECK COMBINATION METER INPUT SIGNAL

1. Turn ignition switch ON.
2. Check the voltage and waveform between combination meter harness connector and ground.

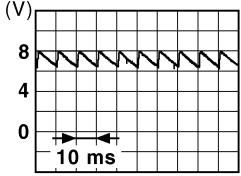
Terminals		Condition	Voltage and waveform
(+)	(-)		
Combination meter Connector	Terminal		
M53	27	Parking brake applied	Approx. 0 V
		Parking brake released	 <p style="text-align: right; font-size: small;">JSNIA0007GB</p>

Is the inspection result normal?

- YES >> INSPECTION END
 NO >> GO TO 2.

2. CHECK PARKING BRAKE SWITCH SIGNAL CIRCUIT

1. Turn ignition switch OFF.
2. Disconnect combination meter connector and parking brake switch connector.
3. Check continuity between combination meter harness connector and parking brake switch harness connector.

Combination meter		Parking brake switch		Continuity
Connector	Terminal	Connector	Terminal	
M53	27	E107	1	Existed

4. Check continuity between combination meter harness connector and ground.

Combination meter		Ground	Continuity
Connector	Terminal		
M53	27		

Is the inspection result normal?

- YES >> INSPECTION END
 NO >> Repair harness or connector.

Component Inspection

INFOID:000000010577075

1. CHECK PARKING BRAKE SWITCH

Check parking brake switch. Refer to [BRC-99, "Component Inspection"](#).

Is the inspection result normal?

- YES >> INSPECTION END

PARKING BRAKE SWITCH SIGNAL CIRCUIT

< DTC/CIRCUIT DIAGNOSIS >

NO >> Replace parking brake switch.

A

B

C

D

E

F

G

H

I

J

K

L

M

MWI

O

P

WASHER LEVEL SWITCH SIGNAL CIRCUIT

< DTC/CIRCUIT DIAGNOSIS >

WASHER LEVEL SWITCH SIGNAL CIRCUIT

Description

INFOID:000000010577076

Transmits the washer level switch signal to the combination meter.

Diagnosis Procedure

INFOID:000000010577077

1. CHECK WASHER LEVEL SWITCH SIGNAL CIRCUIT

1. Turn ignition switch OFF.
2. Disconnect combination meter connector and washer level switch connector.
3. Check continuity between combination meter harness connector and washer level switch harness connector.

Combination meter		Washer level switch		Continuity
Connector	Terminal	Connector	Terminal	
M53	31	E32	1	Existed

4. Check continuity between combination meter harness connector and ground.

Combination meter		Ground	Continuity
Connector	Terminal		
M53	31		Not existed

5. Check continuity between washer level switch harness connector and ground.

Washer level switch		Ground	Continuity
Connector	Terminal		
E32	2		Existed

Is the inspection result normal?

- YES >> INSPECTION END
NO >> Repair harness or connector.

Component Inspection

INFOID:000000010577078

1. CHECK WASHER LEVEL SWITCH

1. Turn ignition switch OFF.
2. Disconnect washer level switch connector.
3. Check washer level switch.

Terminal	Condition	Continuity
1 - 2	Washer fluid level is low (washer level switch ON)	Existed
	Washer fluid level is normal (washer level switch OFF)	Not existed

Is the inspection result normal?

- YES >> INSPECTION END
NO >> Replace washer level switch. Refer to [WW-120, "Removal and Installation"](#).

COMPASS

< DTC/CIRCUIT DIAGNOSIS >

COMPASS

Wiring Diagram - COMPASS -

INFOID:000000010577079

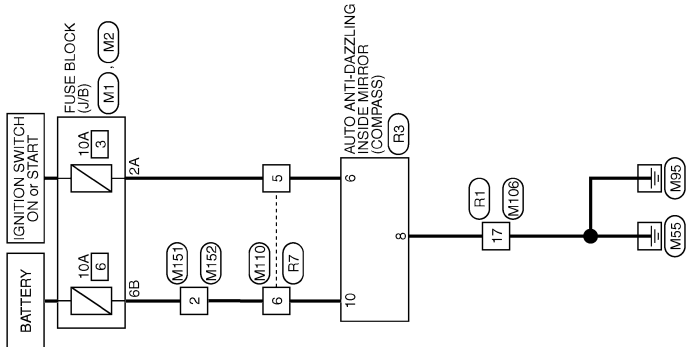

COMPASS

2013/02/13

JRNWC3693GB

A
B
C
D
E
F
G
H
I
J
K
L
M
N
O
P

MWI

COMPASS

< DTC/CIRCUIT DIAGNOSIS >

COMPASS

Connector No.	M1
Connector Name	FUSE BLOCK (J/B)
Connector Type	NS08FW-M2

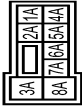
Terminal No.	Wire	Signal Name [Specification]
1A	BG	-
2A	G	-
3A	L	-
4A	R	-
5A	V	-
6A	Y	-
7A	R	-
8A	L	-

Connector No.	M106
Connector Name	WIRE TO WIRE
Connector Type	NH10MW-CS10

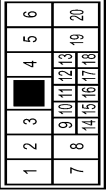

Terminal No.	Wire	Signal Name [Specification]
1	V	-
2	BR	-
3	GR	-
4	SHIELD	-
5	G	-
6	BR	-
7	G	-
8	Y	-
9	G	-
10	Y	-
11	Y	-
12	BR	-
13	L	-
14	L	-
15	R	-
16	R	-
17	B	-
18	B	-
19	B	-
20	B	-

Connector No.	M105
Connector Name	WIRE TO WIRE
Connector Type	NH10MW-CS10

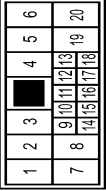

Terminal No.	Wire	Signal Name [Specification]
1	V	-
2	BR	-
3	GR	-
4	SHIELD	-
5	G	-
6	BR	-
7	G	-
8	Y	-
9	G	-
10	Y	-
11	Y	-
12	BR	-
13	L	-
14	L	-
15	R	-
16	R	-
17	B	-
18	B	-
19	B	-
20	B	-

Connector No.	M110
Connector Name	WIRE TO WIRE
Connector Type	TH16MW-NH



Terminal No.	Wire	Signal Name [Specification]
1	W	-
2	Y	-
3	R	-
4	B	-

Connector No.	M152
Connector Name	WIRE TO WIRE
Connector Type	M03MW-LC

Terminal No.	Wire	Signal Name [Specification]
1	W	-
2	Y	-
3	R	-

Connector No.	M151
Connector Name	WIRE TO WIRE
Connector Type	M03FW-LC



Terminal No.	Wire	Signal Name [Specification]
1	V	-
2	BR	-
3	GR	-
4	SHIELD	-
5	G	-
6	BR	-
7	P	-
8	P	-
9	P	-
10	G	-
11	Y	-
12	BR	-
13	L	-
14	L	-
15	R	-
16	R	-
17	B	-
18	B	-
19	B	-
20	Y	-

Connector No.	M1
Connector Name	WIRE TO WIRE
Connector Type	NH10FW-CS10

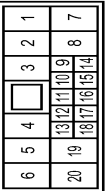
Terminal No.	Wire	Signal Name [Specification]
1	V	-
2	BR	-
3	GR	-
4	SHIELD	-
5	G	-
6	BR	-
7	P	-
8	P	-
9	P	-
10	G	-
11	Y	-
12	BR	-
13	L	-
14	L	-
15	R	-
16	R	-
17	B	-
18	B	-
19	B	-
20	Y	-

Connector No.	R3
Connector Name	AUTO ANTICAZZING MISCIE MIRROR
Connector Type	TH10FB-NH

Terminal No.	Wire	Signal Name [Specification]
6	BR	IGN
8	B	GROUND
10	GR	BAT

JRNWD4435GB

COMPASS

< DTC/CIRCUIT DIAGNOSIS >

A
B
C
D
E
F
G
H
I
J
K
L
M
N
O
P

COMPASS

Connector No.	IR7
Connector Name	WIRE TO WIRE
Connector Type	TH16FW-NH



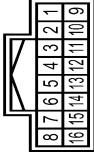

Terminal No.	Color Of Wire	Signal Name [Specification]
1	L	-
2	P	-
3	B	-
4	BR	-
5	GR	-
6	SB	-
7	SHIELD	-
8	R	-
9	G	-
10	R	-
11	G	-
12	R	-
13	G	-
14	R	-
15	G	-
16	V	-

MWI

JRNWD4436GB

CLOCK

< DTC/CIRCUIT DIAGNOSIS >

CLOCK

Wiring Diagram - CLOCK -

INFOID:000000010577080

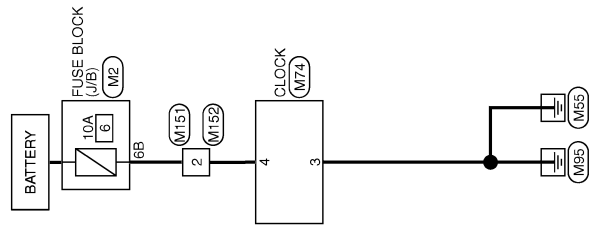

CLOCK

2013/02/13

JRNWC3694GB

CLOCK

< DTC/CIRCUIT DIAGNOSIS >

A
B
C
D
E
F
G
H
I
J
K
L
M
MWI
O
P

CLOCK

Connector No.	M2
Connector Name	FUSE BLOCK (J/B)
Connector Type	NS10FW-GS

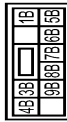

Terminal No.	Color Of Wire	Signal Name [Specification]
1B	LG	-
3B	P	-
4B	G	-
5B	BG	-
7B	L	-
8B	R	-
9B	BR	-

Connector No.	M74
Connector Name	CLOCK
Connector Type	TH04FW-NH



Terminal No.	Color Of Wire	Signal Name [Specification]
1	B	ILLUMINATION (-)
2	R	ILLUMINATION (+)
3	B	GROUND
4	Y	BATTERY POWER SUPPLY

Connector No.	M151
Connector Name	WIRE TO WIRE
Connector Type	M03FW-LC



Terminal No.	Color Of Wire	Signal Name [Specification]
1	W	-
2	Y	-
3	R	-

Connector No.	M152
Connector Name	WIRE TO WIRE
Connector Type	M03MW-LC



Terminal No.	Color Of Wire	Signal Name [Specification]
1	W	-
2	Y	-
3	R	-

COMBINATION METER

< ECU DIAGNOSIS INFORMATION >

ECU DIAGNOSIS INFORMATION

COMBINATION METER

Reference Value

INFOID:000000010577081

VALUES ON THE DIAGNOSIS TOOL

Refer to [MWI-96. "Reference Value"](#).

TERMINAL LAYOUT

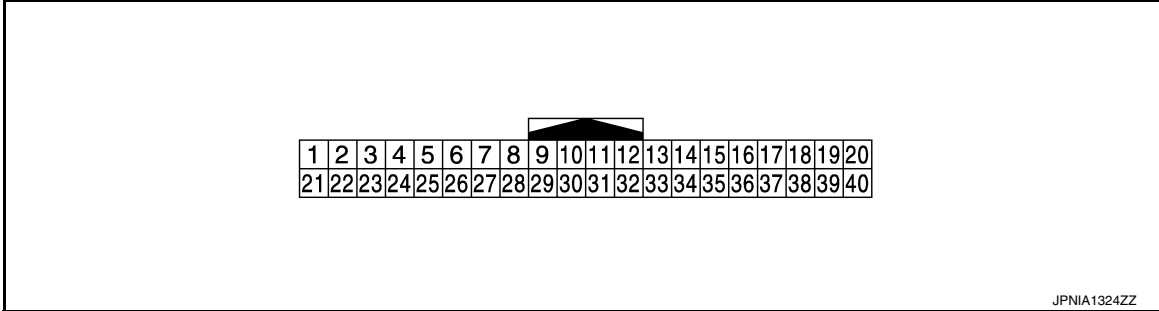

PHYSICAL VALUES

Terminal No. (Wire color)		Description		Condition	Value (Approx.)	
+	-	Signal name	Input/ Output			
1 (BG)	Ground	Battery power supply	Input	Ignition switch OFF	Battery voltage	
2 (LG)	Ground	Communication signal (METER→ AMP.)	Output	Ignition switch ON	<p style="text-align: right;">JSNIA0027GB</p>	
3 (GR)	Ground	Communication signal (AMP.→ METER)	Input	Ignition switch ON	<p style="text-align: right;">JSNIA0027GB</p>	
5 (B)	Ground	Ground	—	Ignition switch ON	0 V	
6 (W)	Ground	Alternator signal	Input	Ignition switch ON	Charge warning lamp ON	0 V
				Ignition switch OFF	Charge warning lamp OFF	Battery voltage
7 (P)	Ground	Air bag signal	Input	Ignition switch ON	Air bag warning lamp ON	4 V
					Air bag warning lamp OFF	0 V
10 (G)	Ground	Security indicator signal	Input	Ignition switch OFF	Security warning lamp ON	0 V
					Security warning lamp OFF	12 V
15 (B)	Ground	Ground	—	Ignition switch ON	0 V	

COMBINATION METER

< ECU DIAGNOSIS INFORMATION >

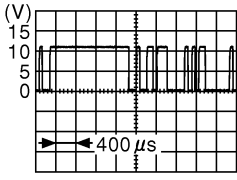
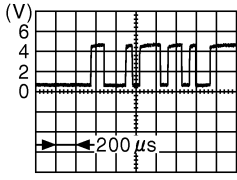
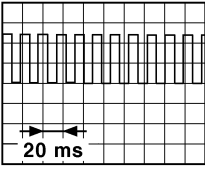
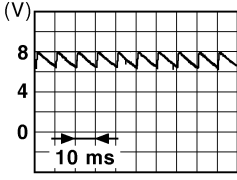



Terminal No. (Wire color)		Description		Condition	Value (Approx.)	
+	-	Signal name	Input/ Output			
16 (B)	Ground	Meter control switch ground	—	Ignition switch ON	0 V	
21 (R)	Ground	Ignition signal	Input	Ignition switch ON	Battery voltage	
24 (BR)	Ground	Communication signal (LCD→AMP.)	Output	Ignition switch ON	 <p style="text-align: right; font-size: small;">JSNIA0028GB</p>	
25 (Y)	Ground	Communication signal (AMP.→LCD)	Input	Ignition switch ON	 <p style="text-align: right; font-size: small;">JSNIA0027GB</p>	
26 (R)	Ground	Vehicle speed signal (8-pulse)	Input	Ignition switch ON	<p>NOTE: The maximum voltage varies depending on the specification (destination unit).</p>  <p style="text-align: right; font-size: small;">JSNIA0012GB</p>	
27 (V)	Ground	Parking brake switch signal	Input	Ignition switch ON	Parking brake ON	0 V
				Ignition switch ON	Parking brake OFF	 <p style="text-align: right; font-size: small;">JSNIA0007GB</p>
28 (W)	Ground	Brake fluid level switch signal	Input	Ignition switch ON	Brake fluid level is normal.	5 V
					The brake fluid level is lower than the low level	0 V
29 (SB)	Ground	Seat belt buckle switch signal (driver side)	Input	Ignition switch ON	When driver seat belt is fastened	12 V
					When driver seat belt is unfastened	0 V

A
B
C
D
E
F
G
H
I
J
K
L
M
O
P

MWI

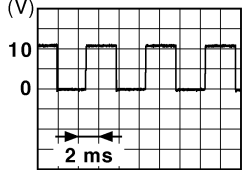
COMBINATION METER

< ECU DIAGNOSIS INFORMATION >

Terminal No. (Wire color)		Description		Condition	Value (Approx.)	
+	-	Signal name	Input/ Output			
30 (G)	Ground	Passenger seat belt warning signal	Input	Ignition switch ON	<ul style="list-style-type: none"> When getting in the passenger seat When passenger seat belt is fastened 	12 V
					<ul style="list-style-type: none"> When getting in the passenger seat When passenger seat belt is unfastened 	0 V
31 (L)	Ground	Washer level switch signal	Input	Ignition switch ON	Washer level switch ON	0 V
					Washer level switch OFF	5 V
34 (B)	Ground	Illumination control signal	Output	Ignition switch ON	Lighting switch ON, then operate the illumination control switch.	NOTE: When brightness level is midway (V) 
36 (LG)	16 (B)	Select switch signal	Input	Ignition switch ON	When  is pressed	0 V
					Other than the above	5 V
37 (SB)	16 (B)	Enter switch signal	Input	Ignition switch ON	When  is pressed	0 V
					Other than the above	5 V
38 (L)	16 (B)	Trip A/B reset switch signal	Input	Ignition switch ON	When trip A/B reset switch is pressed	0 V
					Other than the above	5 V
39 (P)	16 (B)	Illumination control switch signal (-)	Input	Ignition switch ON	When  switch is pressed	0 V
					Other than the above	5 V
40 (BG)	16 (B)	Illumination control switch signal (+)	Input	Ignition switch ON	When  switch is pressed	0 V
					Other than the above	5 V

JSNIA0010GB

COMBINATION METER

< ECU DIAGNOSIS INFORMATION >

Wiring Diagram - METER -

INFOID:0000000110577082

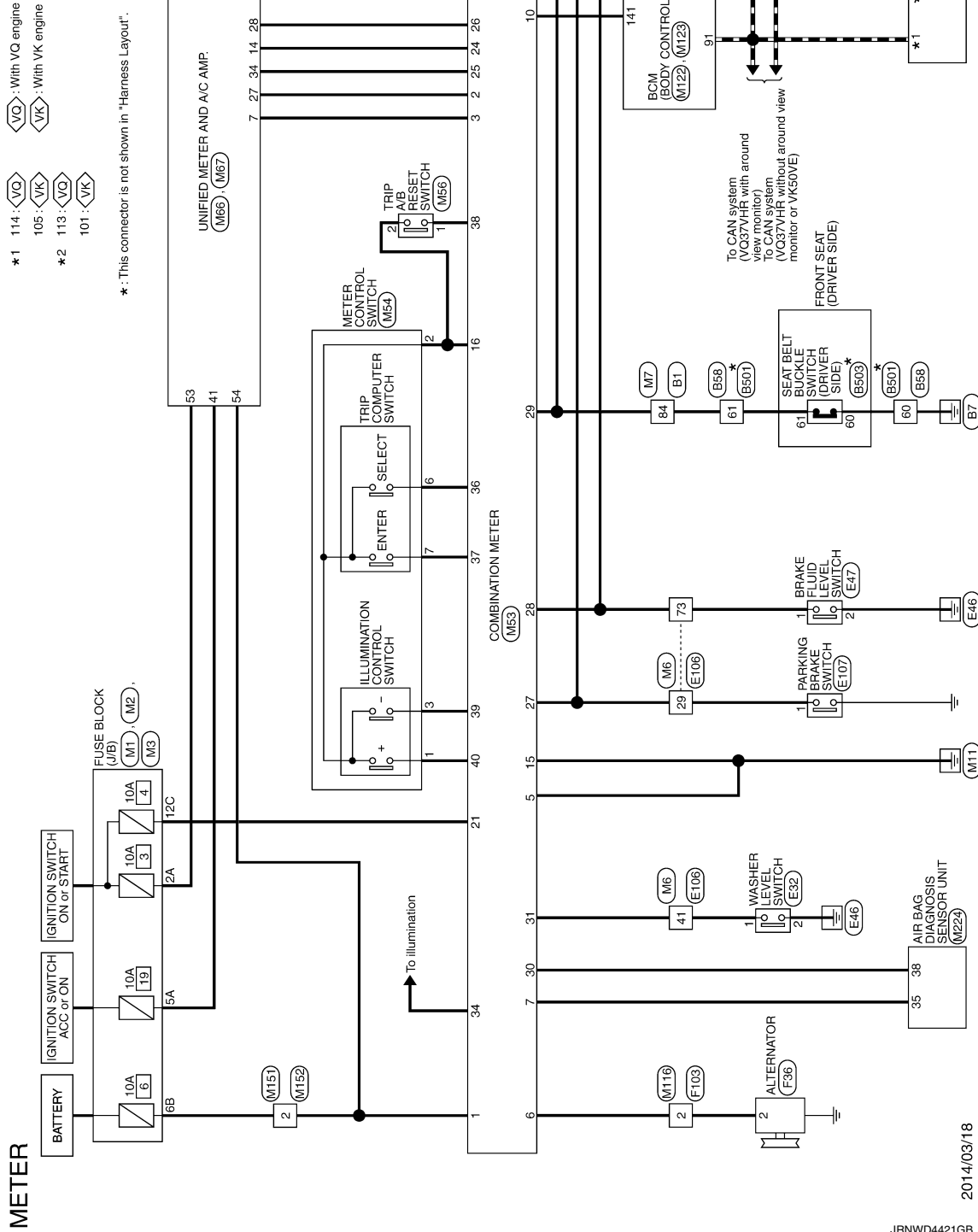

A
B
C
D
E
F
G
H
I
J
K
L
M
N
O
P

MWI

COMBINATION METER

< ECU DIAGNOSIS INFORMATION >

- AW : AWD models
- NV : With NAVI
- ON : Without NAVI
- SS : With paddle shifter
- IC : With ICC

* : This connector is not shown in "Harness Layout".

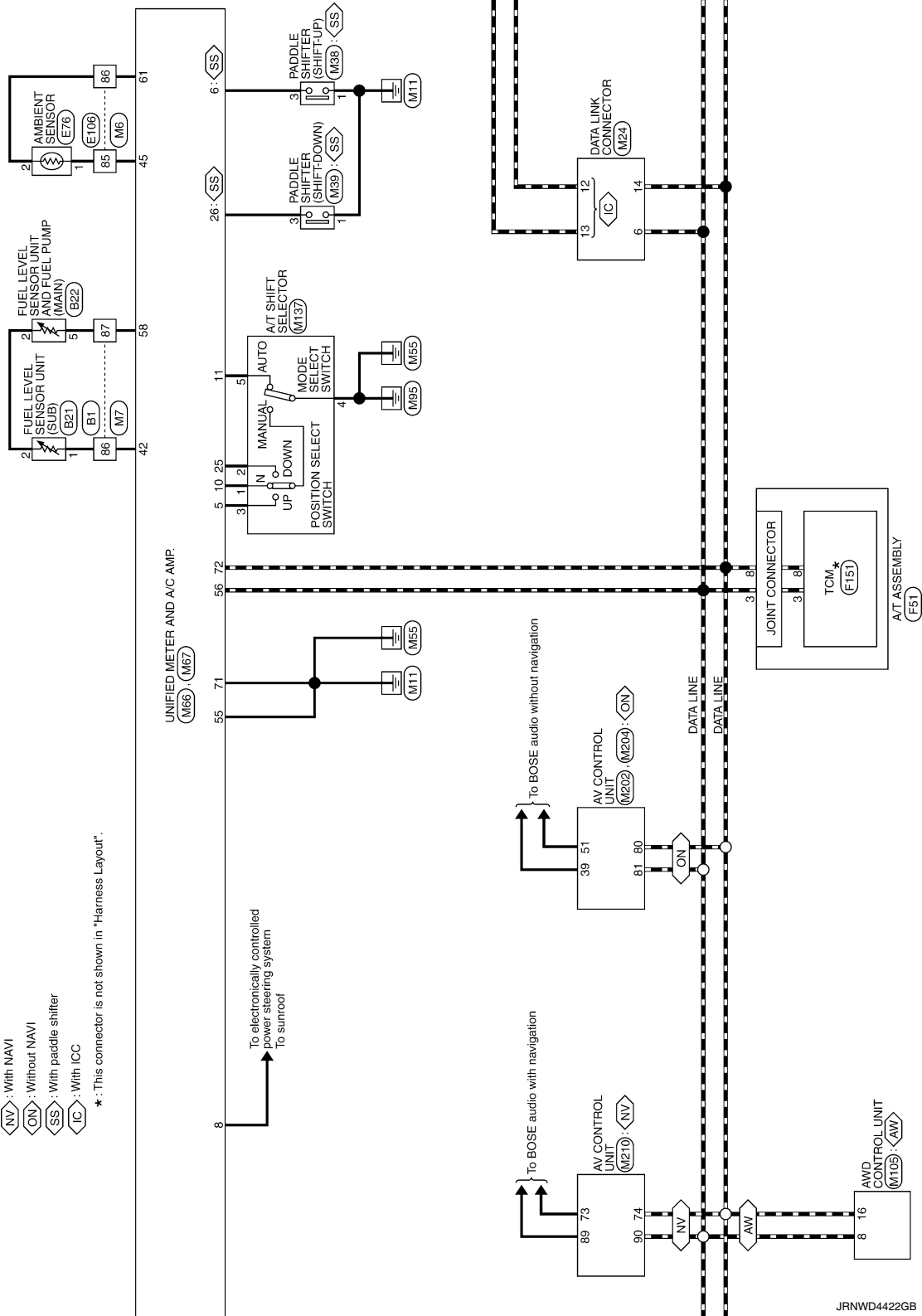

JRNWD4422GB

COMBINATION METER

< ECU DIAGNOSIS INFORMATION >

- : With VQ engine
- : With YK engine
- : With ICC

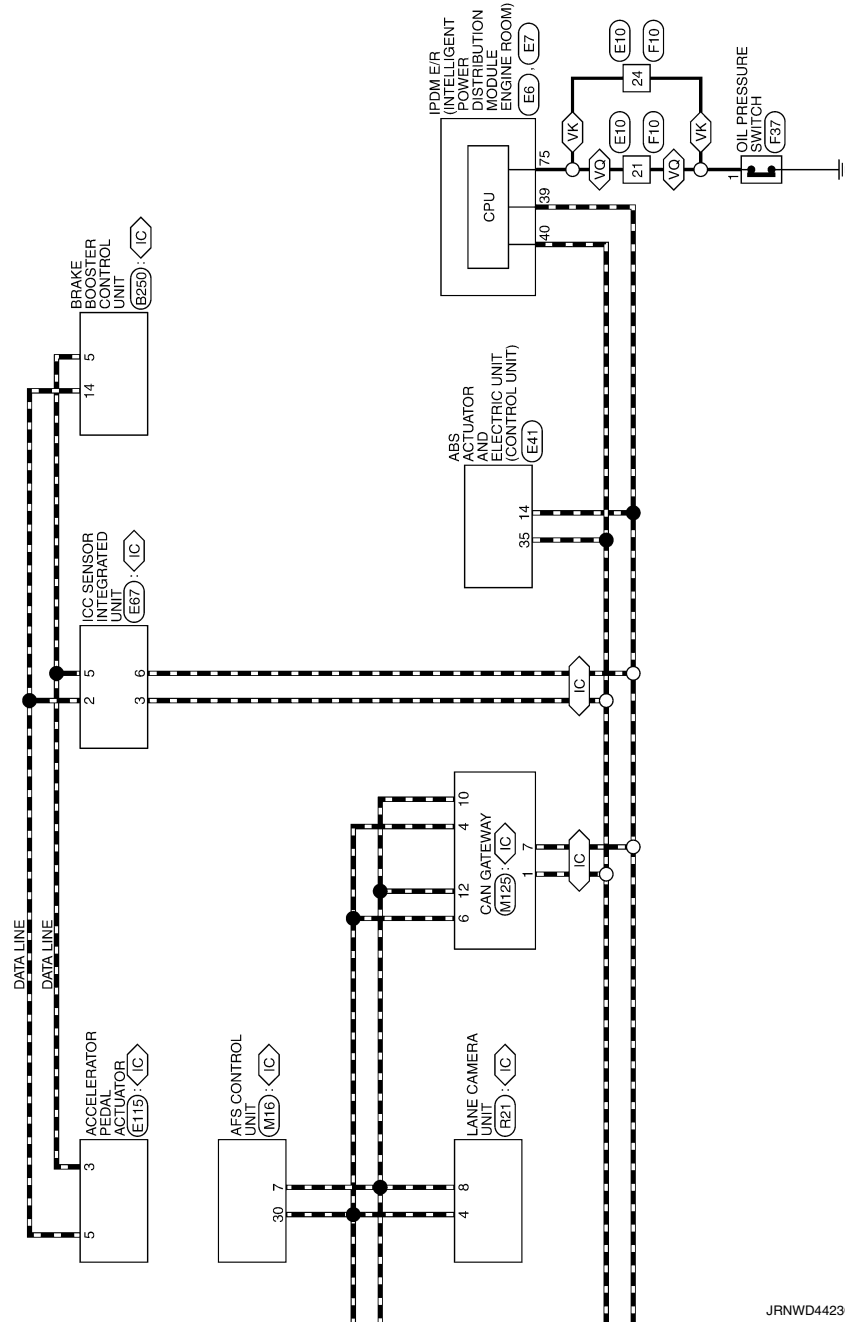

JRNWD4423GB

A
B
C
D
E
F
G
H
I
J
K
L
M
N
O
P

MWI

COMBINATION METER

< ECU DIAGNOSIS INFORMATION >

METER

Connector No.	B1
Connector Name	WIRE TO WIRE
Connector Type	TH80FW-CS16-TM4



Terminal No.	Color Of Wire	Signal Name [Specification]
1	G	-
2	L	-
3	W	-
4	G	-
7	D	-
8	BG	-
10	SB	-
11	SB	-
12	B	-
13	G	-
14	R	-
15	W	-
16	SHIELD	-
17	L	-
18	P	-
19	G	-
20	Y	-
21	W	-
23	V	-
24	P	-
25	BR	-
26	GR	-
27	BG	-
28	W	-
38	B	-
39	B	-
43	SB	-
44	V	-
45	GR	-
51	V	-
52	SB	-
53	SHIELD	-
54	BR	-
55	Y	-
56	SHIELD	-

57	P	-
58	L	-
59	SHIELD	-
60	L	-
61	P	-
62	GR	-
63	G	-
64	BG	-
65	W	-
66	V	-
67	LG	-
68	Y	-
69	G	-
70	GR	-
71	G	-
72	B	-
73	W	-
74	V	-
75	BG	-
76	LG	-
77	L	-
78	GR	-
79	W	-
80	L	-
81	P	-
82	L	-
83	P	-
84	SB	-
85	R	-
86	Y	-
87	B	-
88	G	-
89	BR	-
91	R	-
92	BG	-
93	BR	-
94	V	-
96	BG	-
97	W	-
98	GR	-
99	W	-

Connector No.	B21
Connector Name	FUEL LEVEL SENSOR UNIT (SUB)
Connector Type	E02FGY-RS



Terminal No.	Color Of Wire	Signal Name [Specification]
1	Y	-
2	W	-

Connector No.	B22
Connector Name	FUEL LEVEL SENSOR UNIT AND FUEL PUMP (MAIN)
Connector Type	E05FGY-RS

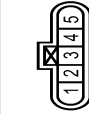

Terminal No.	Color Of Wire	Signal Name [Specification]
1	BR	- [With VK engine]
1	GR	- [With EVAP and VQ engine]
1	L	- [Without EVAP and VQ engine]
2	W	-
3	B	- [Without EVAP and VQ engine]
3	G	- [With VK engine]
3	GY	- [With EVAP and VQ engine]
4	R	-
5	B	-

Connector No.	B58
Connector Name	WIRE TO WIRE
Connector Type	NS10FM-CS

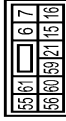

Terminal No.	Color Of Wire	Signal Name [Specification]
6	V	-
7	GR	-
15	BR	-
16	P	-
21	BG	-
55	G	-
56	L	-
59	LG	-
60	B	-
61	SB	-

Connector No.	B250
Connector Name	BRAKE BOOSTER CONTROL UNIT
Connector Type	TK24FW

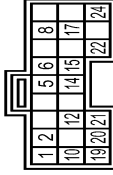

Terminal No.	Color Of Wire	Signal Name [Specification]
1	W	BATTERY
2	W	BATTERY
5	P	ITS COMM L
6	SB	RELEASE SW PWR
8	R	BRAKE PRESSURE SEN PWR
10	G	BOOSTER SOL GND
12	R	BOOSTER SOL GND
14	L	ITS COMM H
15	V	RELEASE SW (NC)

COMBINATION METER

< ECU DIAGNOSIS INFORMATION >

METER

Terminal No.	Color Of Wire	Signal Name [Specification]
17	G	BRAKE PRESSURE SEN SIGNAL
19	B	GROUND
20	B	GROUND
21	GR	CHIME SIGNAL
22	BR	RELEASE SW (NO)
24	BG	BRAKE PRESSURE SEN GND

Connector No.	B501
Connector Name	WIRE TO WIRE
Connector Type	NS10MW-CS

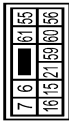

Terminal No.	Color Of Wire	Signal Name [Specification]
6	R	-
7	L	-
15	W	-
16	G	-
21	P	-
55	W	-
56	B	-
59	L/Y	-
60	R/Y	-
61	B/Y	-

Connector No.	B503
Connector Name	SEAT BELT BUCKLE SWITCH (DRIVER SIDE)
Connector Type	A03FW

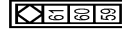

Terminal No.	Color Of Wire	Signal Name [Specification]
59	R/Y	-
60	R/Y	-
61	B/Y	-

Connector No.	E6
Connector Name	POWER INTELLIGENT POWER DISTRIBUTION MODULE (ENGINE ROOM)
Connector Type	TH08FW-AH

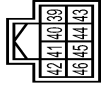

Terminal No.	Color Of Wire	Signal Name [Specification]
39	P	-
40	L	-
41	B	-
42	Y	-
43	SB	-
44	W	-
45	G	-
46	BR	-

Connector No.	E7
Connector Name	POWER INTELLIGENT POWER DISTRIBUTION MODULE (ENGINE ROOM)
Connector Type	TH20FW-CS12-M4

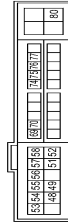

Terminal No.	Color Of Wire	Signal Name [Specification]
48	L	-
49	SB	- [With VQ engine]
49	W	- [With VK engine]
51	G	-
52	W	-

53	W	-
54	R	-
55	BR	-
56	BG	- [With VK engine]
57	V	- [With VQ engine]
57	LG	-
58	Y	-
59	W	-
70	BG	-
74	G	-
75	Y	-
76	P	- [With VK engine]
76	V	- [With VQ engine]
77	B	- [With VK engine]
77	L	- [With VQ engine]
80	W	-

Connector No.	E10
Connector Name	WIRE TO WIRE
Connector Type	SA036MB-RSS-SH28

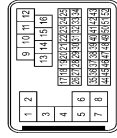

Terminal No.	Color Of Wire	Signal Name [Specification]
1	G	- [With VQ engine]
1	SHIELD	- [With VK engine]
2	L	- [With VQ engine]
2	SHIELD	- [With VK engine]
3	BR	- [With VQ engine]
3	G	- [With VK engine]
4	BR	- [With VQ engine]
4	SHIELD	- [With VK engine]
5	BR	- [With VQ engine]
5	G	- [With VK engine]
6	BR	- [With VQ engine]
6	R	- [With VK engine]
7	C	- [With VQ engine]
7	W	- [With VK engine]
8	SHIELD	- [With VQ engine]
8	W	- [With VK engine]
9	W	-
10	G	- [With VQ engine]

10	W	- [With VK engine]
11	R	- [With VQ engine]
11	W	- [With VK engine]
12	BR	- [With VQ engine]
12	W	- [With VK engine]
13	L	- [With VQ engine]
13	R	- [With VK engine]
14	LG	-
15	BG	- [With VK engine]
15	BR	- [With VQ engine]
16	V	- [With VK engine]
16	W	- [With VQ engine]
17	P	-
18	W	-
19	W	-
20	BR	-
21	SP	- [With VK engine]
21	Y	- [With VQ engine]
22	G	- [With VK engine]
22	W	- [With VQ engine]
23	R	- [With VK engine]
23	V	- [With VQ engine]
24	G	- [With VK engine]
24	Y	- [With VQ engine]
25	LG	-
26	LG	-
27	G	- [With VK engine]
27	GR	- [With VQ engine]
28	GR	- [With VK engine]
28	V	- [With VQ engine]
29	P	-
30	L	- [With VQ engine]
30	W	- [With VK engine]
31	G	- [With VK engine]
31	W	- [With VQ engine]
32	L	- [With VK engine]
32	V	- [With VQ engine]
33	BG	- [With VK engine]
33	W	- [With VQ engine]
34	BG	-
35	R	-
36	SHIELD	-
37	SHIELD	- [With VQ engine]
38	Y	- [With VK engine]
38	L	- [With VQ engine]
38	SHIELD	- [With VK engine]
39	P	- [With VQ engine]
39	W	- [With VK engine]
40	R	- [With VQ engine]
40	SHIELD	- [With VK engine]

A
B
C
D
E
F
G
H
I
J
K
L
M
MWI
O
P

COMBINATION METER

< ECU DIAGNOSIS INFORMATION >

METER

41	W	- [With V6 engine]
41	Y	- [With VK engine]
42	LG	- [With V6 engine]
42	SHIELD	- [With VK engine]
43	G	- [With V6 engine]
44	G	- [With VK engine]
45	L	-
46	SHIELD	- [With V6 engine]
47	B	- [With VK engine]
47	W	- [With V6 engine]
48	BR	- [With VK engine]
48	R	- [With V6 engine]
49	G	- [With VK engine]
49	L	- [With V6 engine]
50	B	- [With VK engine]
50	G	- [With V6 engine]
51	B	- [With VK engine]
51	SB	- [With V6 engine]
52	R	-

Connector No.	E32
Connector Name	WASHER LEVEL SWITCH
Connector Type	202FBR



Terminal No.	Color Of Wire	Signal Name [Specification]
1	LG	-
2	B/W	-

Connector No.	E41
Connector Name	ABS ACTUATOR AND ELECTRIC UNIT (CONTROL UNIT)
Connector Type	BAA42FB-AH4-LH



Terminal No.	Color Of Wire	Signal Name [Specification]
1	B	GROUND
2	G	GROUND
3	R	LBVR
4	B	GROUND
5	V	DS FL
6	BG	DP RL
7	BR	DP RR
9	B	DP FR
10	W	DS FR
12	L	VAC
14	P	CANL
15	SHIELD	AGND
19	P	UST
25	Y	BUS-L
26	R	DP FL
27	GR	DS RL
28	G	UZ
29	LG	DS RR
30	SB	BLS
31	R	VDC OFF SW
35	L	CAN-H
45	B	BUS-H

Connector No.	E47
Connector Name	BRAKE FLUID LEVEL SWITCH
Connector Type	YV02FGY



Terminal No.	Color Of Wire	Signal Name [Specification]
1	R	-
2	B	-

Connector No.	E67
Connector Name	ICC SENSOR INTEGRATED UNIT
Connector Type	RS06FB-PR



Terminal No.	Color Of Wire	Signal Name [Specification]
1	R	IGNITION
2	L	ITS COMM-H
3	L	CAN-H
4	B	GROUND
5	P	ITS COMM-L
6	P	CAN-L

Connector No.	E76
Connector Name	AMBIENT SENSOR
Connector Type	RS02FB



Terminal No.	Color Of Wire	Signal Name [Specification]
1	G	-
2	P	-

Connector No.	E106
Connector Name	WIRE TO WIRE
Connector Type	TH60FW-CS16-TM4

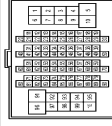

Terminal No.	Color Of Wire	Signal Name [Specification]
1	G	-
2	BG	-
3	SB	-
4	LG	-
5	Y	-
6	W	-
7	G	-
8	V	-
9	R	-
10	BR	-
11	B	-
12	G	-
13	R	-
14	W	-
15	SHIELD	-
16	SB	-
17	L	-
18	P	-

JRNWD4426GB

COMBINATION METER

< ECU DIAGNOSIS INFORMATION >

METER

19	G	-	-	-	-
20	W	-	-	-	- [With ICC]
21	Y	-	-	-	- [Without ICC]
22	BR	L	-	-	- [With ICC]
23	R	W	-	-	- [Without ICC]
24	V	LG	-	-	- [With ICC]
25	G	GR	-	-	- [Without ICC]
26	L	P	-	-	- [With ICC]
27	L	W	-	-	- [Without ICC]
28	Y	-	-	-	- [With ICC]
29	G	BR	LG	-	-
30	LG	BR	GR	-	-
31	BG	BR	-	-	-
32	W	SB	-	-	-
33	Y	W	-	-	-
34	BG	W	-	-	-
37	Y	-	-	-	-
38	GR	-	-	-	-
39	LG	-	-	-	-
41	LG	-	-	-	-
42	V	-	-	-	-
43	R	-	-	-	-
44	G	-	-	-	-
45	GR	-	-	-	-
46	W	-	-	-	-
47	L	-	-	-	-
48	P	-	-	-	-
49	SB	-	-	-	-
50	BR	-	-	-	-
51	B	-	-	-	-
52	Y	-	-	-	-
53	BG	-	-	-	-
54	R	-	-	-	-
55	SB	-	-	-	-
59	P	-	-	-	-
60	SB	-	-	-	-
61	V	-	-	-	-
62	P	-	-	-	-
63	LG	-	-	-	-
64	L	-	-	-	-
65	BG	-	-	-	-
69	L	-	-	-	-
70	SHIELD	-	-	-	-
71	G	-	-	-	-
72	G	-	-	-	-
73	R	-	-	-	-
74	BR	-	-	-	-
76	L	-	-	-	-

77	W	-	-	-	-
78	Y	-	-	-	-
80	SB	-	-	-	-
81	L	-	-	-	-
82	W	-	-	-	-
83	LG	-	-	-	-
84	GR	-	-	-	-
85	G	-	-	-	-
86	P	-	-	-	-
87	W	-	-	-	-
88	BG	-	-	-	-
89	LG	-	-	-	-
90	BR	-	-	-	-
91	GR	-	-	-	-
92	BR	-	-	-	-
93	SB	-	-	-	-
95	Y	-	-	-	-
96	W	-	-	-	-
97	W	-	-	-	-
98	SHIELD	-	-	-	-
100	Y	-	-	-	-

Connector No.	E107
Connector Name	PARKING BRAKE SWITCH
Connector Type	TBD1FW



Terminal No.	1
Color	LG
Wire	-
Signal Name [Specification]	-

Connector No.	E115
Connector Name	ACCELERATOR PEDAL ACTUATOR
Connector Type	KDZ06FB



Terminal No.	Color	Wire	Signal Name [Specification]
1	R	-	IGNITION
2	BG	-	BATTERY
3	P	-	ITS COM+L
4	B	-	GROUND
5	L	-	ITS COM+H

Connector No.	F10
Connector Name	WIRE TO WIRE
Connector Type	SAAG3FB-RS9-SH28

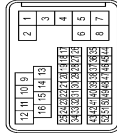

Terminal No.	Color	Wire	Signal Name [Specification]
1	G	-	[With VQ engine]
2	SHIELD	-	[With VK engine]
3	Y	-	[With VQ engine]
4	BR	-	[With VK engine]
5	G	-	[With VQ engine]
6	BR	-	[With VK engine]
7	SHIELD	-	[With VQ engine]
8	W	-	[With VK engine]
9	G	-	[With VQ engine]
10	SHIELD	-	[With VK engine]
11	R	-	[With VQ engine]
12	SHIELD	-	[With VK engine]

8	W	-	-	-	- [With VQ engine]
9	W	-	-	-	-
10	G	-	-	-	-
11	R	-	-	-	- [With VK engine]
12	Y	-	-	-	- [With VQ engine]
13	P	-	-	-	- [With VK engine]
14	V	-	-	-	- [With VQ engine]
15	L	-	-	-	- [With VK engine]
16	L	-	-	-	- [With VQ engine]
17	LG	-	-	-	- [With VK engine]
18	O	-	-	-	- [With VQ engine]
19	O	-	-	-	-
20	R	-	-	-	-
21	V	-	-	-	- [With VK engine]
22	B	-	-	-	- [With VQ engine]
23	G	-	-	-	- [With VK engine]
24	LG	-	-	-	- [With VQ engine]
25	V	-	-	-	- [With VK engine]
26	O	-	-	-	-
27	GR	-	-	-	- [With VQ engine]
28	BR	-	-	-	- [With VK engine]
29	L	-	-	-	- [With VQ engine]
30	GR	-	-	-	- [With VK engine]
31	BR	-	-	-	- [With VQ engine]
32	G	-	-	-	- [With VK engine]
33	L	-	-	-	- [With VQ engine]
34	O	-	-	-	- [With VK engine]
35	P	-	-	-	-
36	SHIELD	-	-	-	-
37	SHIELD	-	-	-	- [With VQ engine]
38	SHIELD	-	-	-	- [With VK engine]
38	W	-	-	-	- [With VQ engine]

A
B
C
D
E
F
G
H
I
J
K
L
M
N
O
P

MWI

COMBINATION METER

< ECU DIAGNOSIS INFORMATION >

METER

39	W	- [With VK engine]
39	Y	- [With VQ engine]
40	G	- [With VQ engine]
40	SHIELD	- [With VK engine]
41	B	- [With VQ engine]
41	Y	- [With VK engine]
42	GR	- [With VQ engine]
42	SHIELD	- [With VK engine]
43	R	- [With VQ engine]
43	W	- [With VK engine]
44	LG	-
45	L	-
46	G	- [With VK engine]
46	SHIELD	- [With VQ engine]
47	B	- [With VK engine]
47	W	- [With VQ engine]
48	LG	- [With VK engine]
48	R	- [With VQ engine]
49	G	- [With VK engine]
49	L	- [With VQ engine]
50	B	- [With VK engine]
50	G	- [With VQ engine]
51	B	- [With VK engine]
51	W	- [With VQ engine]
52	R	-

Connector No.	F-36
Connector Name	ALTERNATOR
Connector Type	HS03FB



Terminal No.	Color Of Wire	Signal Name [Specification]
2	G	L
3	O	S [With VK engine]
3	V	S [With VQ engine]
4	P	C [With VK engine]
4	W	C [With VQ engine]

Connector No.	F-37
Connector Name	OIL PRESSURE SWITCH
Connector Type	EDTGY-RS-AR



Terminal No.	Color Of Wire	Signal Name [Specification]
1	Y	-

Connector No.	F-51
Connector Name	AT ASSEMBLY
Connector Type	RK0FG-DGY



Terminal No.	Color Of Wire	Signal Name [Specification]
1	Y	IGNITION POWER SUPPLY
2	R	BATTERY POWER SUPPLY (MEMORY BACK-UP)
3	L	CAN-H
4	V	K-LINE
5	B	GROUND
6	Y	IGNITION POWER SUPPLY
7	R	BACK-UP LAMP RELAY
8	P	CAN-L
9	GR	STARTER RELAY [With VQ engine]
9	LG	STARTER RELAY [With VK engine]
10	B	GROUND

Connector No.	F-103
Connector Name	WIRE TO WIRE
Connector Type	TK38FW-NS10

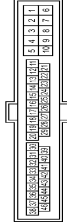

Terminal No.	Color Of Wire	Signal Name [Specification]
2	G	-
3	W	-
4	GR	- [With VK engine]
4	R	- [With VQ engine]
5	B	- [With VQ engine]
5	R	- [With VK engine]
7	B	-
9	W	- [With VK engine]
9	Y	- [With VQ engine]
10	GR	- [With VQ engine]
10	L	- [With VK engine]
19	O	-
20	Y	-
27	L	-
28	B	-
29	LG	-
31	R	-
34	LG	-
35	BR	-
36	W	-
37	Y	-
38	P	-
44	L	-
45	Y	-
46	V	-

Connector No.	F-151
Connector Name	TCM
Connector Type	SP10FG



Terminal No.	Color Of Wire	Signal Name [Specification]
1	W	IGNITION POWER SUPPLY
2	B	BATTERY POWER SUPPLY (MEMORY BACK-UP)
3	R	CAN-H
4	O	K-LINE
5	G	GROUND
6	GR	IGNITION POWER SUPPLY
7	L	BACK-UP LAMP RELAY
8	BR	CAN-L
9	Y	STARTER RELAY
10	WB	GROUND

Connector No.	M1
Connector Name	FUSE BLOCK (J/B)
Connector Type	NS06FW-M2

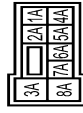

Terminal No.	Color Of Wire	Signal Name [Specification]
1A	BG	-
2A	G	-
3A	L	-
4A	R	-
5A	V	-
6A	Y	-
7A	R	-
8A	L	-

JRNWD4428GB

COMBINATION METER

< ECU DIAGNOSIS INFORMATION >

METER

Connector No.	M2
Connector Name	FUSE BLOCK (J/B)
Connector Type	NS10FM-CS

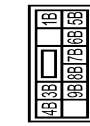

Terminal No.	Color Of Wire	Signal Name [Specification]
1B	LG	-
3B	P	-
4B	G	-
5B	BG	-
7B	Y	-
8B	L	-
9B	R	-
9B	BR	-

Connector No.	M3
Connector Name	FUSE BLOCK (J/B)
Connector Type	NS12FM-CS

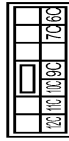

Terminal No.	Color Of Wire	Signal Name [Specification]
10C	L	-
11C	LG	-
12C	R	-
7C	B	-
9C	BG	-

Connector No.	M6
Connector Name	WIRE TO WIRE
Connector Type	TH80MW-CS16-TM4

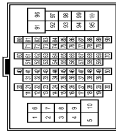

Terminal No.	Color Of Wire	Signal Name [Specification]
1	G	-
2	BG	-
3	LG	- [Without Auto aircon seat]
3	SB	- [With Auto aircon seat]
4	G	-
5	GR	-
6	W	-
7	G	-
8	W	-
9	P	-
10	BR	-
11	B	-
12	G	-
13	R	-
14	W	-
15	SHIELD	-
16	BR	-
17	L	-
18	P	-
19	G	-
20	GR	- [Without ICC]
21	BR	- [With ICC]
21	R	- [Without ICC]
22	L	- [Without ICC]
22	R	- [With ICC]
23	G	-
24	L	-
24	P	- [Without ICC]
25	W	- [Without ICC]
25	Y	- [With ICC]
26	SHIELD	-
28	GR	-
29	V	-
30	BG	-
32	W	-

33	Y	-
34	L	-
37	G	-
38	R	-
39	G	-
41	L	-
42	W	-
43	R	-
44	LG	-
45	GR	-
46	W	-
47	L	-
48	P	-
49	BG	-
50	LG	-
51	SB	-
52	Y	-
53	BG	-
54	BR	-
55	SB	-
59	SB	-
60	SB	-
61	V	-
62	P	-
63	R	-
64	L	-
65	BG	-
69	V	-
70	SHIELD	-
71	BG	-
72	GR	-
73	W	-
74	SB	-
76	V	-
77	V	-
78	Y	-
80	BG	-
81	L	-
82	W	-
83	Y	-
84	L	-
85	P	-
86	BR	-
87	P	-
88	V	-
89	G	-
90	P	-
91	R	-
92	R	-
93	GR	-

95	G	-
96	W	-
97	W	-
98	SHIELD	-
100	Y	-

Connector No.	M7
Connector Name	WIRE TO WIRE
Connector Type	TH80MW-CS16-TM4



Terminal No.	Color Of Wire	Signal Name [Specification]
1	G	- [With Auto aircon seat]
1	Y	- [Without Auto aircon seat]
2	B	-
3	W	-
6	P	-
7	V	-
8	BG	-
10	W	-
11	BG	-
12	B	-
13	G	-
14	R	-
15	W	-
16	SHIELD	-
17	L	-
18	P	-
19	G	-
20	R	-
21	LG	-
23	V	-
24	P	-
25	BR	-
26	GR	-
27	BG	-
28	W	-
38	B	-
39	B	-
43	SB	-
44	W	-

A
B
C
D
E
F
G
H
I
J
K
L
M
N
O
P

MWI

COMBINATION METER

< ECU DIAGNOSIS INFORMATION >

Terminal No.	Color Of Wire	Signal Name [Specification]
45	B	-
51	V	-
52	LG	-
53	SHIELD	-
54	BR	-
55	Y	-
56	SHIELD	-
57	P	-
58	L	-
59	SHIELD	-
60	L	-
61	BR	-
62	R	-
63	Y	-
64	L	-
65	W	-
66	V	-
67	LG	-
68	Y	-
69	G	-
70	V	-
71	W	-
72	B	-
73	W	-
74	LG	-
75	P	-
76	LG	-
77	SB	-
78	GR	-
79	R	-
80	L	-
81	P	-
82	L	-
83	P	-
84	SB	-
85	W	-
86	Y	-
87	B	-
88	G	-
89	BG	-
91	R	-
92	BG	-
93	BR	-
94	V	-
96	BG	-
97	W	-
98	R	-
99	BG	-

Connector No.	M16	M24	M38	M52
Connector Name	AFS CONTROL UNIT	DATA LINK CONNECTOR	PADDLE SHIFTER (SHIFT-DOWN)	COMBINATION METER
Connector Type	TH00FM-NH	BD18FW	A03FW	TH00FM-NH

Terminal No.	Color Of Wire	Signal Name [Specification]
1	Y	IGN
2	LG	PSGR
4	Y	PSGR
6	W	HSVR
7	P	CANL
8	B	HSGR
9	GR	PSR
11	R	SMR-1 (-)
13	B	SMR-2 (-)
15	G	SML-1 (+)
17	W	SML-2 (+)
19	SB	AMDS-R
24	V	PSVL
25	B	GROUND
27	BR	PSG-L
28	SB	HSR
29	BG	PS-L
30	L	CAN-H
32	G	SMR-2 (+)
34	W	SMR-1 (+)
36	R	SML-2 (-)
38	B	SML-1 (-)
40	BG	AMDS-L

Terminal No.	Color Of Wire	Signal Name [Specification]
3	LG	-
4	B	-
5	B	-
6	L	-
7	GR	-
8	G	-
11	SB	-
12	P	-
13	L	-
14	P	-
16	BG	-

Terminal No.	Color Of Wire	Signal Name [Specification]
1	BG	BATTERY POWER SUPPLY
2	LG	COMMUNICATION SIGNAL (METER->AMP)
3	GR	COMMUNICATION SIGNAL (AMP->METER)
5	B	GROUND
6	W	ALTERNATOR SIGNAL
7	P	AIR BAG SIGNAL
10	G	SECURITY INDICATOR SIGNAL
15	B	GROUND
16	B	METER CONTROL SWITCH GROUND
21	R	IGNITION SIGNAL
24	BR	COMMUNICATION SIGNAL (LCD->AMP)
25	Y	COMMUNICATION SIGNAL (AMP->LCD)
26	R	VEHICLE SPEED SIGNAL (8-PULSE)
27	V	PARKING BRAKE SWITCH SIGNAL
28	W	BRAKE FLUID LEVEL SWITCH SIGNAL
29	SB	SEAT BELT SWITCH SIGNAL (LOWER SIDE)
30	G	PASSENGER SEAT BELT WARNING SIGNAL
31	L	WASHER LEVEL SWITCH SIGNAL

Terminal No.	Color Of Wire	Signal Name [Specification]
1	B	-
3	BG	-

Terminal No.	Color Of Wire	Signal Name [Specification]
1	B	-
3	BG	-

JRNWD4430GB

COMBINATION METER

< ECU DIAGNOSIS INFORMATION >

METER

34	B	ILLUMINATION CONTROL SIGNAL
36	LG	SELECT SWITCH SIGNAL
37	SB	ENTER SWITCH SIGNAL
38	L	TRIP AB RESET SWITCH SIGNAL
39	P	ILLUMINATION CONTROL SWITCH SIGNAL (-)
40	BG	ILLUMINATION CONTROL SWITCH SIGNAL (+)

Connector No.	M54
Connector Name	METER CONTROL SWITCH
Connector Type	TH12MW-NH

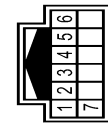

Terminal No.	Color Of Wire	Signal Name [Specification]
1	BG	-
2	B	-
3	P	-
4	R	-
5	B	-
6	LG	-
7	SB	-

Connector No.	M56
Connector Name	TRIP AB RESET SWITCH
Connector Type	TH04MW-NH



Terminal No.	Color Of Wire	Signal Name [Specification]
1	L	-
2	B	-

Connector No.	M66
Connector Name	UNIFIED METER AND A/C AMP.
Connector Type	TH01FW-NH

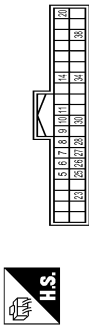

Terminal No.	Color Of Wire	Signal Name [Specification]
5	L	MANUAL MODE SHIFT UP SIGNAL
6	BG	PADDLE SHIFTER UP SIGNAL
7	GR	COMMUNICATION SIGNAL (AMP->METER)
8	L	VEHICLE SPEED SIGNAL (2-PULSE)
9	SB	SEAT BELT BRACKE SWITCH SIGNAL (DRIVER SIDE)
10	W	MANUAL MODE SIGNAL
11	G	NONMANUAL MODE SIGNAL
14	BR	COMMUNICATION SIGNAL (LCD->AMP.)
20	L	ION SENSOR SIGNAL
23	Y	AT SNOW SWITCH SIGNAL
25	V	MANUAL MODE SHIFT DOWN SIGNAL
26	G	PADDLE SHIFTER DOWN SIGNAL
27	LG	COMMUNICATION SIGNAL (METER->AMP.)
28	R	VEHICLE SPEED SIGNAL (8-PULSE)
30	V	PARKING BRAKE SWITCH SIGNAL
34	Y	COMMUNICATION SIGNAL (AMP->LCD)
38	L	BLOWER MOTOR CONTROL SIGNAL

Connector No.	M67
Connector Name	UNIFIED METER AND A/C AMP.
Connector Type	TH02FW-NH

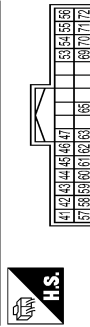

Terminal No.	Color Of Wire	Signal Name [Specification]
41	V	ACC POWER SUPPLY
42	Y	FUEL LEVEL SENSOR SIGNAL
43	R	INTAKE SENSOR SIGNAL

44	LG	IN-VEHICLE SENSOR SIGNAL
45	P	AMBIENT SENSOR SIGNAL
46	BG	SUNLOAD SENSOR SIGNAL
47	V	GAS SENSOR SIGNAL
53	G	IGNITION POWER SUPPLY
54	BG	BATTERY POWER SUPPLY
55	B	GROUND
56	L	CANH
57	W	BRAKE FLUID LEVEL SWITCH SIGNAL
58	B	FUEL LEVEL SENSOR GROUND
59	GR	INTAKE SENSOR GROUND
60	L	IN-VEHICLE SENSOR GROUND
61	BR	AMBIENT SENSOR GROUND
62	SB	SUNLOAD SENSOR GROUND
63	R	IGN MODE SIGNAL
65	BG	ECV SIGNAL
69	L	A/C LAMP SIGNAL
70	R	EACH DOOR MOTOR POWER SUPPLY
71	B	GROUND
72	P	CANL

Connector No.	M105
Connector Name	AWD CONTROL UNIT
Connector Type	TH18FW-NH

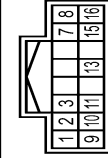

Terminal No.	Color Of Wire	Signal Name [Specification]
1	BR	AWD SOL (+)
2	Y	AWD SOL (-)
3	W	FLUID TEMP (-)
7	GR	IGN
8	L	CANH
9	BG	AWD SOL BAT
10	B	GROUND
11	B	GROUND
13	LG	FLUID TEMP (+)
15	Y	BATTERY
16	P	CANL

Connector No.	M116
Connector Name	WIRE TO WIRE
Connector Type	TK38MW-NS10

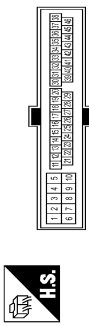

Terminal No.	Color Of Wire	Signal Name [Specification]
2	W	-
3	L	-
4	B	- [With VK engine]
4	R	- [With VQ engine]
5	B	- [With VQ engine]
5	R	- [With VK engine]
7	B	-
9	L	- [With VK engine]
9	R	- [With VQ engine]
10	R	-
19	BG	-
20	Y	-
27	L	-
28	B	-
29	LG	-
31	W	-
34	LG	-
35	BR	-
36	W	-
37	Y	-
38	BG	-
43	P	-
44	L	-
45	G	-
46	Y	-

A
B
C
D
E
F
G
H
I
J
K
L
M
N
O
P

MWI

COMBINATION METER

< ECU DIAGNOSIS INFORMATION >

METER

Connector No.	M122
Connector Name	BCM (BODY CONTROL MODULE)
Connector Type	TH40FB-NH

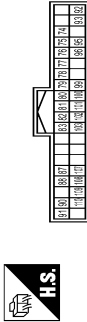

Terminal No.	Color Of Wire	Signal Name [Specification]
74	SB	PASSENGER DOOR ANT-
75	BR	PASSENGER DOOR ANT+
76	V	DRIVER DOOR ANT-
77	LG	DRIVER DOOR ANT+
78	Y	ROOM ANTI-
79	BR	ROOM ANTI+
80	GR	WATS ANT AMP-
81	W	WATS ANT AMP+
82	P	IGN RELAY (P/B) CONT
83	GR	KEYLESS ENTRY RECEIVER SIGNAL
87	BR	COMBI SW INPUT 5
88	V	COMBI SW INPUT 3
90	P	CANL
91	L	CANH
92	LG	KEY SLOT ILL
93	V	ON IND
95	BG	ACC RELAY CONT
96	GR	ANT SELECTOR POWER SUPPLY
99	R	SHIFT P
100	G	PASSENGER DOOR REQUEST SW
101	SB	DRIVER DOOR REQUEST SW
102	BG	BLOWER FAN MOTOR RELAY CONT
103	BR	KEYLESS ENTRY RECEIVER POWER SUPPLY
107	LG	COMBI SW INPUT 1
108	R	COMBI SW INPUT 4
109	Y	COMBI SW INPUT 2
110	G	HAZARD SW

Connector No.	M123
Connector Name	BCM (BODY CONTROL MODULE)
Connector Type	TH40FG-NH

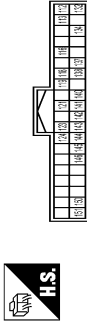

Terminal No.	Color Of Wire	Signal Name [Specification]
112	GR	RAIN SENSOR SERIAL LINK
113	P	OPTICAL SENSOR
116	BR	STOP LAMP SW 1
118	B	STOP LAMP SW 2
119	SB	DR DOOR UNLOCK SENSOR
121	BR	KEY SLOT SW
123	W	IGN P/B
124	LG	PASSENGER DOOR SW
132	BG	POWER WINDOW SW COM1
134	GR	LOCK IND
137	B	RECEIVER SENSOR GND
138	Y	SENSOR POWER SUPPLY
140	R	SHIFT N/P
141	G	SECURITY INDICATOR OUTPUT
142	BG	COMBI SW OUTPUT 5
143	P	COMBI SW OUTPUT 1
144	G	COMBI SW OUTPUT 2
145	L	COMBI SW OUTPUT 3
146	SB	COMBI SW OUTPUT 4
150	GR	DRIVER DOOR SW
151	G	REAR WINDOW DEFROGGER RELAY CONT

Connector No.	M125
Connector Name	CAN GATEWAY
Connector Type	TH12FM-NH



Terminal No.	Color Of Wire	Signal Name [Specification]
1	L	CANH
3	GR	BATTERY
4	L	CANH
5	B	GROUND
6	L	CANH
7	P	CANL
8	LG	IGNITION
10	P	CANL
11	B	GROUND
12	P	CANL

Connector No.	M137
Connector Name	AT SHIFT SELECTOR
Connector Type	TH12FM-NH



Terminal No.	Color Of Wire	Signal Name [Specification]
1	W	-
2	V	-
3	L	-
4	B	-
5	G	-
7	BG	-
8	SB	-
9	B	-
10	GR	-
11	R	-

Connector No.	M151
Connector Name	WIRE TO WIRE
Connector Type	M03FW-LC



Terminal No.	Color Of Wire	Signal Name [Specification]
1	W	-
2	Y	-
3	R	-

Connector No.	M152
Connector Name	WIRE TO WIRE
Connector Type	M03MW-LC



Terminal No.	Color Of Wire	Signal Name [Specification]
1	W	-
2	Y	-
3	R	-

JRNWD4432GB

COMBINATION METER

< ECU DIAGNOSIS INFORMATION >

A
B
C
D
E
F
G
H
I
J
K
L
M
MWI
O
P

METER

Connector No.	M160
Connector Name	ECM
Connector Type	RH24FGY-RZ8-RH-Z



Terminal No.	Color	Wire	Signal Name [Specification]
97	R	R	ENGINE SPEED SIGNAL OUTPUT
98	G	G	SENSOR POWER SUPPLY
99	G	G	SENSOR POWER SUPPLY
100	P	P	CAN COMMUNICATION LINE
102	SB	SB	ASC/DC STEERING SWITCH
104	R	R	ACCELERATOR POSITION SENSOR 1
105	L	L	CAN COMMUNICATION LINE
106	L	L	IGNITION SWITCH
108	P	P	ACCELERATOR PEDAL POSITION SENSOR 2
110	P	P	STOP LAMP SWITCH
111	V	V	SENSOR GROUND
112	LG	LG	FUEL PUMP CONTROL MODULE (FFCM) CHECK
114	GR	GR	DATA LINK CONNECTOR
115	GR	GR	SENSOR GROUND
116	G	G	TRANSMISSION RANGE SWITCH
117	BR	BR	ASC/DC BRAKE SWITCH
118	R	R	POWER SUPPLY FOR ECM (BACK-UP)
119	W	W	SENSOR GROUND
120	W	W	FUEL TANK TEMPERATURE SENSOR
121	GR	GR	POWER SUPPLY FOR ECM
123	B	B	ECM GROUND
125	R	R	FUEL PUMP CONTROL MODULE (FFCM)
128	B	B	ECM GROUND

Connector No.	M164
Connector Name	ECM
Connector Type	RH24FGY-RZ8-RH-Z



Terminal No.	Color	Wire	Signal Name [Specification]
97	R	R	ACCELERATOR PEDAL POSITION SENSOR 1
98	P	P	ACCELERATOR PEDAL POSITION SENSOR 2 (PULSE)
99	V	V	ACCELERATOR PEDAL POSITION SENSOR 2 (PULSE)
88	G	G	SENSOR POWER SUPPLY (With NAVI)
89	L	L	SENSOR POWER SUPPLY (Without NAVI)
100	W	W	SENSOR GROUND
101	SB	SB	ASC/DC STEERING SWITCH
102	LG	LG	EVAP CONTROL SYSTEM PRESSURE SENSOR
103	G	G	SENSOR POWER SUPPLY (Without NAVI)
104	L	L	SENSOR GROUND (With NAVI)
104	BR	BR	SENSOR GROUND (Without NAVI)
105	L	L	REFRIGERANT PRESSURE SENSOR
106	W	W	FUEL TANK TEMPERATURE SENSOR
107	BG	BG	SENSOR POWER SUPPLY
108	V	V	SENSOR GROUND
109	G	G	PNP SIGNAL
110	R	R	ENGINE SPEED OUTPUT SIGNAL
112	V	V	ENGINE SPEED OUTPUT SIGNAL (WITH PRESSURE SENSOR)
113	P	P	CAN COMMUNICATION LINE
114	L	L	CAN COMMUNICATION LINE
117	GR	GR	DATA LINK CONNECTOR
121	LG	LG	EVAP CANISTER VENT CONTROL VALVE
122	P	P	STOP LAMP SWITCH
123	B	B	ECM GROUND
124	B	B	ECM GROUND
125	GR	GR	POWER SUPPLY FOR ECM
126	BR	BR	ASC/DC BRAKE SWITCH
127	B	B	ECM GROUND
128	B	B	ECM GROUND

Connector No.	M202
Connector Name	AV CONTROL UNIT
Connector Type	TH24FM-NH



Terminal No.	Color	Wire	Signal Name [Specification]
36	BG	BG	SIGNAL VCC
37	LG	LG	SIGNAL GND
38	R	R	VP
39	BR	BR	COMM (DISP->CONT)
40	B	B	RGB AREA (VS) SIGNAL
41	SHIELD	SHIELD	SHIELD
42	G	G	RGB SYNC
43	B	B	RGB (R/RED) SIGNAL
44	W	W	RGB (G/GREEN) SIGNAL
45	R	R	RGB (B/BLUE) SIGNAL
46	BG	BG	COMPOSITE IMAGE SIGNAL GND
47	SB	SB	COMPOSITE IMAGE SIGNAL
48	Y	Y	INVERTER VCC
49	BR	BR	INVERTER GND
50	W	W	VP
51	Y	Y	COMM (CONT->DISP)
52	SB	SB	SHIELD
57	SHIELD	SHIELD	SHIELD

Connector No.	M204
Connector Name	AV CONTROL UNIT
Connector Type	TH24FM-NH



Terminal No.	Color	Wire	Signal Name [Specification]
76	LG	LG	AV COMM (L)
77	SB	SB	AV COMM (H)
78	LG	LG	AV COMM (L)
79	SB	SB	AV COMM (H)
80	P	P	CANL
81	L	L	CANH
82	BR	BR	SW GND
86	SHIELD	SHIELD	SHIELD
87	L	L	TEL VOICE SIGNAL (*)
88	P	P	TEL VOICE SIGNAL (L)
92	R	R	VEHICLE SPEED SIGNAL (8-PULSE)
93	V	V	PARKING BRAKE SIGNAL
94	BG	BG	REVERSE SIGNAL
95	G	G	IGNITION SIGNAL
96	SB	SB	DISK EJECT SIGNAL
102	B	B	AUX GND
103	W	W	AUX AUDIO L/H+
104	R	R	AUX AUDIO R/H+

Connector No.	M210
Connector Name	AV CONTROL UNIT
Connector Type	TH24FW-NH

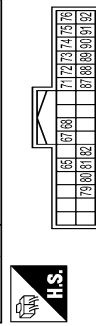

Terminal No.	Color	Wire	Signal Name [Specification]
65	V	V	PARKING BRAKE SIGNAL
67	B	B	COMPOSITE IMAGE SIGNAL GND
68	R	R	COMPOSITE IMAGE SIGNAL
71	SHIELD	SHIELD	MICROPHONE SHIELD
72	G	G	MICROPHONE VCC
73	R	R	COMM (CONT->DISP)
74	P	P	CANL
75	LG	LG	AV COMM (L)
76	LG	LG	AV COMM (L)
78	R	R	ILLUMINATION
80	G	G	IGNITION SIGNAL
81	BG	BG	REVERSE SIGNAL
82	R	R	VEHICLE SPEED SIGNAL (8-PULSE)
87	R	R	MICROPHONE SIGNAL

COMBINATION METER

< ECU DIAGNOSIS INFORMATION >

METER		R21	
88	B SHIELD	Connector No.	LANE CAMERA UNIT
89	G COMM (DISP->CONT)	Connector Name	
90	L CANH	Connector Type	TH98FM-NH
91	SB AV COMM (H)		
92	SB AV COMM (H)		

M224		TH98FM-NH	
Connector No.	AIR BAG DIAGNOSIS SENSOR UNIT	Terminal No.	Signal Name [Specification]
Connector Name		1	B GROUND
Connector Type	NH28FY-EX	2	SB WARNING SYSTEMS ON INDICATOR
		3	Y WARNING SYSTEMS SWITCH
		4	L CANH
		5	B GROUND
		6	R LANE DEPARTURE WARNING BUZZER
		7	Y IGNITION POWER SUPPLY
		8	P CANL

M224		NH28FY-EX	
Connector No.	AIR BAG DIAGNOSIS SENSOR UNIT	Terminal No.	Signal Name [Specification]
Connector Name		23	Y INFLATOR AS2+
Connector Type	NH28FY-EX	24	Y INFLATOR AS2-
		25	Y INFLATOR AS1-
		26	Y INFLATOR AS1+
		27	B GND
		28	Y INFLATOR DR2+
		29	Y INFLATOR DR1+3DR2-
		30	Y INFLATOR DR+
		31	V ECZS-
		32	BR SIDE SENS RH2-
		34	G SIDE SENS LH2-
		35	P A/B W/L
		38	G SEATBELT W/L
		39	SHIELD GND
		41	SB ECZS+
		42	Y SIDE SENS RH2+
		44	R SIDE SENS LH2+
		45	P CAN LO
		46	L CAN HI
		47	P A/B CUTOFF TELLTALE
		50	LG IGN

Fail-Safe

FAIL-SAFE

Combination meter performs fail-safe operation when unified meter and A/C amp. communication is malfunction.

Solution for communication error between the unified meter and A/C amp. and combination meter.

JRNWD4434GB

INFOID:000000010577083

COMBINATION METER

< ECU DIAGNOSIS INFORMATION >

Function		Specifications	
Speedometer		Reset to zero by suspending communication.	A
Tachometer			B
Fuel gauge			C
Engine coolant temperature gauge			D
Illumination control		When suspending communication, change to nighttime mode.	E
Information display		The display turns off by suspending communication.	F
Buzzer		The buzzer turns off by suspending communication.	G
Warning lamp/indicator lamp	ABS warning lamp	The lamp turns on by suspending communication.	H
	VDC OFF indicator lamp		I
	Brake warning lamp		J
	CRUISE warning lamp		K
	IBA OFF indicator lamp		L
	Malfunction indicator lamp		M
	High beam indicator	The lamp turns off by suspending communication.	N
	Turn signal indicator lamp		O
	Tail lamp indicator lamp		P
	Oil pressure warning lamp		Q
	A/T CHECK warning lamp		R
	VDC warning lamp		S
	AWD warning lamp		T
	Low tire pressure warning lamp		U
	Key warning lamp		V
	AFS OFF indicator lamp		W
	Lane departure warning lamp		X
LDP ON indicator lamp	Y		
Master warning lamp	Z		

DTC Index

INFOID:000000010577084

Refer to [MWI-117, "DTC Index"](#).

MWI

UNIFIED METER AND A/C AMP.

< ECU DIAGNOSIS INFORMATION >

UNIFIED METER AND A/C AMP.

Reference Value

INFOID:000000010577085

VALUES ON THE DIAGNOSIS TOOL

NOTE:

The following table includes information (items) inapplicable to this vehicle. For information (items) applicable to this vehicle, refer to CONSULT display items.

CONSULT MONITOR ITEM

Monitor Item	Condition		Value/Status
SPEED METER [km/h] or [mph]	Ignition switch ON	While driving	Equivalent to speedometer reading NOTE: 655.35 is displayed when the malfunction signal is received
SPEED OUTPUT [km/h] or [mph]	Ignition switch ON	While driving	Equivalent to speedometer reading NOTE: 655.35 is displayed when the malfunction signal is received
ODO OUTPUT [km/h]	Ignition switch ON	—	Equivalent to odometer reading in combination meter
TACHO METER [rpm]	Ignition switch ON	While driving	Equivalent to tachometer reading NOTE: 8191.875 is displayed when the malfunction signal is received
FUEL METER [L]	Ignition switch ON	—	Values according to fuel level
W TEMP METER [°C] or [°F]	Ignition switch ON	—	Values according to engine coolant temperature NOTE: 215 is displayed when the malfunction signal is input
FUEL CAP W/L	Ignition switch ON	Fuel filler cap warning display ON	On
		Fuel filler cap warning display OFF	Off
ABS W/L	Ignition switch ON	ABS warning lamp ON	On
		ABS warning lamp OFF	Off
VDC/TCS IND	Ignition switch ON	VDC OFF indicator lamp ON	On
		VDC OFF indicator lamp OFF	Off
SLIP IND	Ignition switch ON	VDC warning lamp ON	On
		VDC warning lamp OFF	Off
BRAKE W/L	Ignition switch ON	Brake warning lamp ON	On
		Brake warning lamp OFF	Off
DOOR W/L	Ignition switch ON	Door warning displayed	On
		Door warning not displayed	Off
HI-BEAM IND	Ignition switch ON	Hi-beam indicator lamp ON	On
		Hi-beam indicator lamp OFF	Off
TURN IND	Ignition switch ON	Turn indicator lamp ON	On
		Turn indicator lamp OFF	Off
FR FOG IND	Ignition switch ON	Front fog indicator lamp ON	On
		Front fog indicator lamp OFF	Off
RR FOG IND	Ignition switch ON	NOTE: This item is displayed, but cannot be monitored.	Off

UNIFIED METER AND A/C AMP.

< ECU DIAGNOSIS INFORMATION >

Monitor Item	Condition		Value/Status	
LIGHT IND	Ignition switch ON	Tail lamp indicator lamp ON	On	A
		Tail lamp indicator lamp OFF	Off	
OIL W/L	Ignition switch ON	Oil pressure warning lamp ON	On	B
		Oil pressure warning lamp OFF	Off	
MIL	Ignition switch ON	Malfunction warning lamp ON	On	C
		Malfunction warning lamp OFF	Off	
GLOW IND	Ignition switch ON	NOTE: This item is displayed, but cannot be monitored.	Off	D
C-ENG2 W/L	Ignition switch ON	NOTE: This item is displayed, but cannot be monitored.	Off	E
CRUISE IND	Ignition switch ON	CRUISE indicator displayed	On	
		CRUISE indicator not displayed	Off	
SET IND	Ignition switch ON	SET indicator displayed ON	On	F
		SET indicator not displayed OFF	Off	
CRUISE W/L	Ignition switch ON	CRUISE warning lamp ON	On	G
		CRUISE warning lamp OFF	Off	
BA W/L	Ignition switch ON	IBA OFF indicator lamp ON	On	H
		IBA OFF indicator lamp OFF	Off	
ATC/T-AMT W/L	Ignition switch ON	A/T check warning lamp ON	On	
		A/T check warning lamp OFF	Off	I
4WD W/L	Ignition switch ON	AWD warning lamp ON	On	
		AWD warning lamp OFF	Off	J
4WD LOCK IND	Ignition switch ON	NOTE: This item is displayed, but cannot be monitored.	Off	
FUEL W/L	Ignition switch ON	Low-fuel warning displayed	On	K
		Low-fuel warning not displayed	Off	
WASHER W/L	Ignition switch ON	Washer warning displayed	On	L
		Washer warning not displayed	Off	
AIR PRES W/L	Ignition switch ON	Low tire pressure lamp ON	On	
		Low tire pressure lamp OFF	Off	M
KEY G/Y W/L	Ignition switch ON	Key warning lamp ON	On	
		Key warning lamp OFF	Off	MWI
AFS OFF IND	Ignition switch ON	AFS OFF indicator lamp ON	On	
		AFS OFF indicator lamp OFF	Off	
4WAS/RAS W/L	Ignition switch ON	NOTE: This item is displayed, but cannot be monitored.	Off	O
DDS W/L	Ignition switch ON	NOTE: This item is displayed, but cannot be monitored.	Off	P
LANE W/L	Ignition switch ON	Lane departure warning lamp ON	On	
		Lane departure warning lamp OFF	Off	
LDP IND	Ignition switch ON	LDP ON indicator lamp ON	On	
		LDP ON indicator lamp OFF	Off	

UNIFIED METER AND A/C AMP.

< ECU DIAGNOSIS INFORMATION >

Monitor Item	Condition		Value/Status
E-SUS IND	Ignition switch ON	NOTE: This item is displayed, but cannot be monitored.	Off
DCA IND	Ignition switch ON	DCA switch indicator displayed	On
		DCA switch indicator not displayed	Off
LCD	Ignition switch ON	Engine start information display	B&P I
	Ignition switch ACC	Engine start information display	B&P N
	Ignition switch LOCK	Key ID warning display	ID NG
	Ignition switch LOCK	Steering lock information display	ROTAT
	Ignition switch LOCK	P position warning display	SFT P
	Ignition switch LOCK	Intelligent Key insert information display	INSRT
	Ignition switch LOCK	Intelligent Key low battery warning display	BATT
	Ignition switch ON	Take away warning display	NO KY
	Ignition switch LOCK	Key warning display	OUTKY
ACC TARGET	Ignition switch ON	Vehicle ahead detection indicator displayed	On
		Vehicle ahead detection indicator not displayed	Off
ACC DISTANCE	Ignition switch ON	When following distance set to "LONG"	Long
		When following distance set to "MIDDLE"	Middle
		When following distance set to "SHORT"	Short
		Set distance indicator not displayed	Off
ACC OWN VHL	Ignition switch ON	Own vehicle indicator displayed	On
		Own vehicle indicator not displayed	Off
ACC SET SPEED	Ignition switch ON	Set vehicle speed indicator not displayed	Off
		Set vehicle speed indicator displayed	Indicates the set vehicle speed
ACC UNIT	Ignition switch ON	Set vehicle speed indicator unit display ON	On
		Set vehicle speed indicator unit display OFF	Off

UNIFIED METER AND A/C AMP.

< ECU DIAGNOSIS INFORMATION >

Monitor Item	Condition	Value/Status	
SHIFT IND	Ignition switch ON	Shift position indicator P display	P
		Shift position indicator R display	R
		Shift position indicator N display	N
		Shift position indicator D display	D
		Shift position indicator DS display	L
		Shift position indicator M1 display	M1
		Shift position indicator M2 display	M2
		Shift position indicator M3 display	M3
		Shift position indicator M4 display	M4
		Shift position indicator M5 display	M5
		Shift position indicator M6 display	M6
		Shift position indicator M7 display	M7
O/D OFF SW	Ignition switch ON	NOTE: This item is displayed, but cannot be monitored. Off	
AT S MODE SW	Ignition switch ON	Snow mode switch pressed	On
		Snow mode switch not pressed	Off
AT P MODE SW	Ignition switch ON	NOTE: This item is displayed, but cannot be monitored. Off	
M RANGE SW	Ignition switch ON	Selector lever manual mode position	On
		Other than the above	Off
NM RANGE SW	Ignition switch ON	Selector lever manual mode position	Off
		Other than the above	On
AT SFT UP SW	Ignition switch ON	Selector lever + position	On
		Other than the above	Off
AT SFT DWN SW	Ignition switch ON	Selector lever – position	On
		Other than the above	Off
ST SFT UP SW	Ignition switch ON	Paddle shifter switch up operation	On
		Other than the above	Off
ST SFT DWN SW	Ignition switch ON	Paddle shifter switch down operation	On
		Other than the above	Off
COMP F/B SIG	Ignition switch ON	A/C compressor activation condition	On
		A/C compressor deactivation condition	Off
4WD LOCK SW	Ignition switch ON	NOTE: This item is displayed, but cannot be monitored. Off	
PKB SW	Ignition switch ON	Parking brake switch ON	On
		Parking brake switch OFF	Off
BUCKLE SW	Ignition switch ON	Seat belt not fastened	On
		Seat belt fastened	Off
BRAKE OIL SW	Ignition switch ON	Brake fluid level switch ON	On
		Brake fluid level switch OFF	Off
DISTANCE [km/h]	Ignition switch ON	—	Possible driving distance calculated by unified meter and A/C amp.

UNIFIED METER AND A/C AMP.

< ECU DIAGNOSIS INFORMATION >

Monitor Item	Condition		Value/Status
OUTSIDE TEMP [°C] or [°F]	Ignition switch ON	—	Equivalent to ambient temperature NOTE: This may not match the indicated value on the information display.
FUEL LOW SIG	Ignition switch ON	Low-fuel warning signal output	On
		Low-fuel warning signal not output	Off
BUZZER	Ignition switch ON	Buzzer ON	On
		Buzzer OFF	Off

TERMINAL LAYOUT

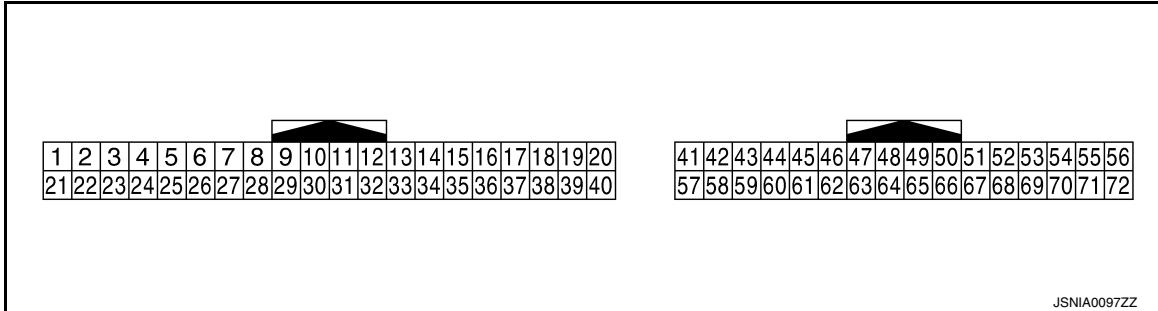

PHYSICAL VALUES

Terminal No. (Wire color)		Description		Condition		Value (Approx.)
+	-	Signal name	Input/ Output			
5 (L)	Ground	Manual mode shift up signal	Input	Ignition switch ON	Selector lever UP operation	0 V
					Other than the above	12 V
6 (BG)	Ground	Paddle shifter up signal	Input	Ignition switch ON	Paddle shifter up operation	0 V
					Other than the above	12 V
7 (GR)	Ground	Communication signal (AMP. → METER)	Output	Ignition switch ON	—	<p style="text-align: right; font-size: small;">JSNIA0027GB</p>
8 (L)	Ground	Vehicle speed signal (2-pulse)	Output	Ignition switch ON	Speedometer operated [When vehicle speed is approx. 40 km/h (25 MPH)]	<p>NOTE: The maximum voltage varies depending on the specification (destination unit).</p> <p style="text-align: right; font-size: small;">JSNIA0015GB</p>
9 (SB)	Ground	Seat belt buckle switch signal (driver side)	Input	Ignition switch ON	When seat belt is fastened	12 V
					When seat belt is not fastened	0 V

UNIFIED METER AND A/C AMP.

< ECU DIAGNOSIS INFORMATION >

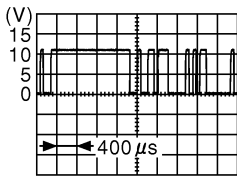
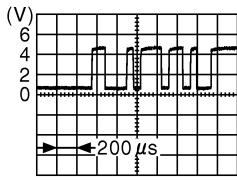
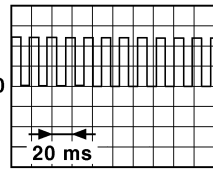
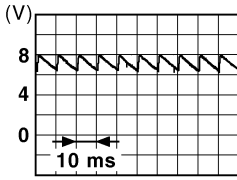
Terminal No. (Wire color)		Description		Condition		Value (Approx.)
+	-	Signal name	Input/ Output			
10 (W)	Ground	Manual mode signal	Input	Ignition switch ON	Selector lever DS position	0 V
					Other than the above	12 V
11 (G)	Ground	Non-manual mode signal	Input	Ignition switch ON	Selector lever DS position	12 V
					Other than the above	0 V
14 (BR)	Ground	Communication signal (LCD → AMP.)	Input	Ignition switch ON	—	 <p style="text-align: right; font-size: small;">JSNIA0028GB</p>
25 (V)	Ground	Manual mode shift down signal	Input	Ignition switch ON	Selector lever down opera- tion	0 V
					Other than the above	12 V
26 (G)	Ground	Paddle shifter down signal	Input	Ignition switch ON	Paddle shifter down opera- tion	0 V
					Other than the above	12 V
27 (LG)	Ground	Communication signal (METER → AMP.)	Input	Ignition switch ON	—	 <p style="text-align: right; font-size: small;">JSNIA0027GB</p>
28 (R)	Ground	Vehicle speed signal (8-pulse)	Output	Ignition switch ON	Speedometer operated [When vehicle speed is ap- prox. 40 km/h (25 MPH)]	<p>NOTE: The maximum voltage varies de- pending on the specification (destination unit).</p>  <p style="text-align: right; font-size: small;">JSNIA0012GB</p>
30 (V)	Ground	Parking brake switch signal	Input	Ignition switch ON	Parking brake ON	0 V
					Parking brake OFF	 <p style="text-align: right; font-size: small;">JSNIA0007GB</p>

A
B
C
D
E
F
G
H
I
J
K
L
M
MWI
O
P

UNIFIED METER AND A/C AMP.

< ECU DIAGNOSIS INFORMATION >

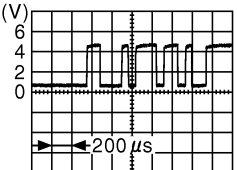
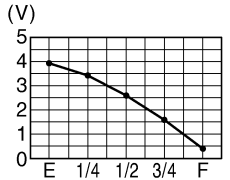
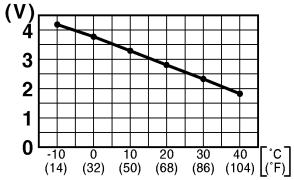
Terminal No. (Wire color)		Description		Condition		Value (Approx.)
+	-	Signal name	Input/ Output			
34 (Y)	Ground	Communication signal (AMP. → LCD)	Output	Ignition switch ON	—	 <p style="text-align: right; font-size: small;">JSNIA0027GB</p>
41 (V)	Ground	ACC power supply	Input	Ignition switch ACC	—	Battery voltage
42 (Y)	Ground	Fuel level sensor signal	Input	Ignition switch ON	—	 <p style="text-align: right; font-size: small;">SKIB8867E</p>
45 (P)	Ground	Ambient sensor signal	Input	—	—	 <p style="text-align: right; font-size: small;">JSNIA0014GB</p>
53 (G)	Ground	Ignition power supply	Input	Ignition switch ON	—	Battery voltage
54 (BG)	Ground	Battery power supply	Input	Ignition switch OFF	—	Battery voltage
55 (B)	Ground	Ground	—	Ignition switch ON	—	0 V
56 (L)	Ground	CAN-H	—	—	—	—
57 (W)	Ground	Brake fluid level switch signal	Input	Ignition switch ON	Brake fluid level is normal.	5 V
					The brake fluid level is lower than the low level	0 V
58 (B)	Ground	Fuel level sensor ground	—	Ignition switch ON	—	0 V
61 (BR)	Ground	Ambient sensor ground	—	Ignition switch ON	—	0 V
71 (B)	Ground	Ground	—	Ignition switch ON	—	0 V
72 (P)	Ground	CAN-L	—	—	—	—

UNIFIED METER AND A/C AMP.

< ECU DIAGNOSIS INFORMATION >

Wiring Diagram - METER -

INFOID:000000011008592

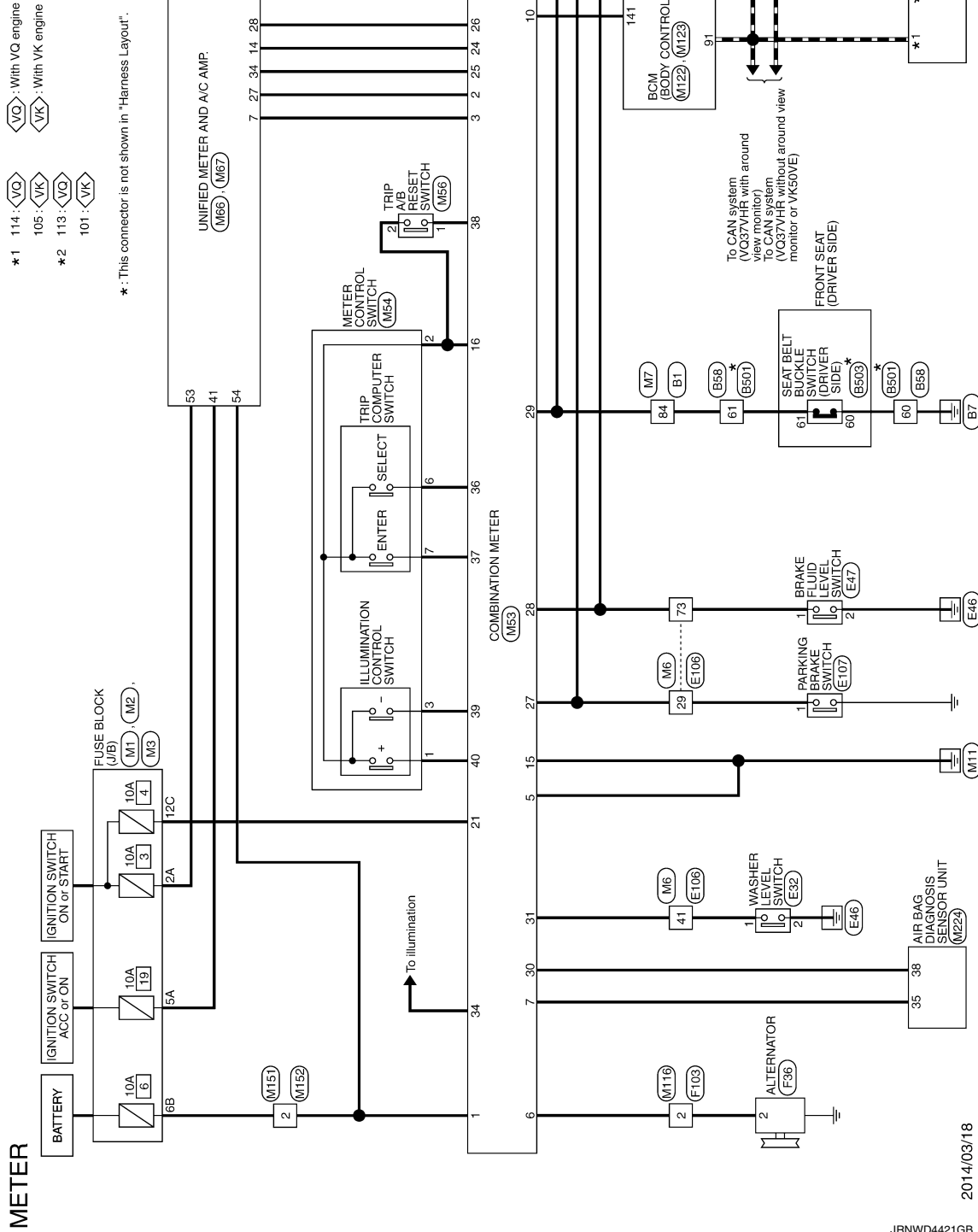

A
B
C
D
E
F
G
H
I
J
K
L
M
N
O
P

MWI

UNIFIED METER AND A/C AMP.

< ECU DIAGNOSIS INFORMATION >

- AW : AWD models
- NV : With NAVI
- ON : Without NAVI
- SS : With paddle shifter
- IC : With ICC

* : This connector is not shown in "Harness Layout".

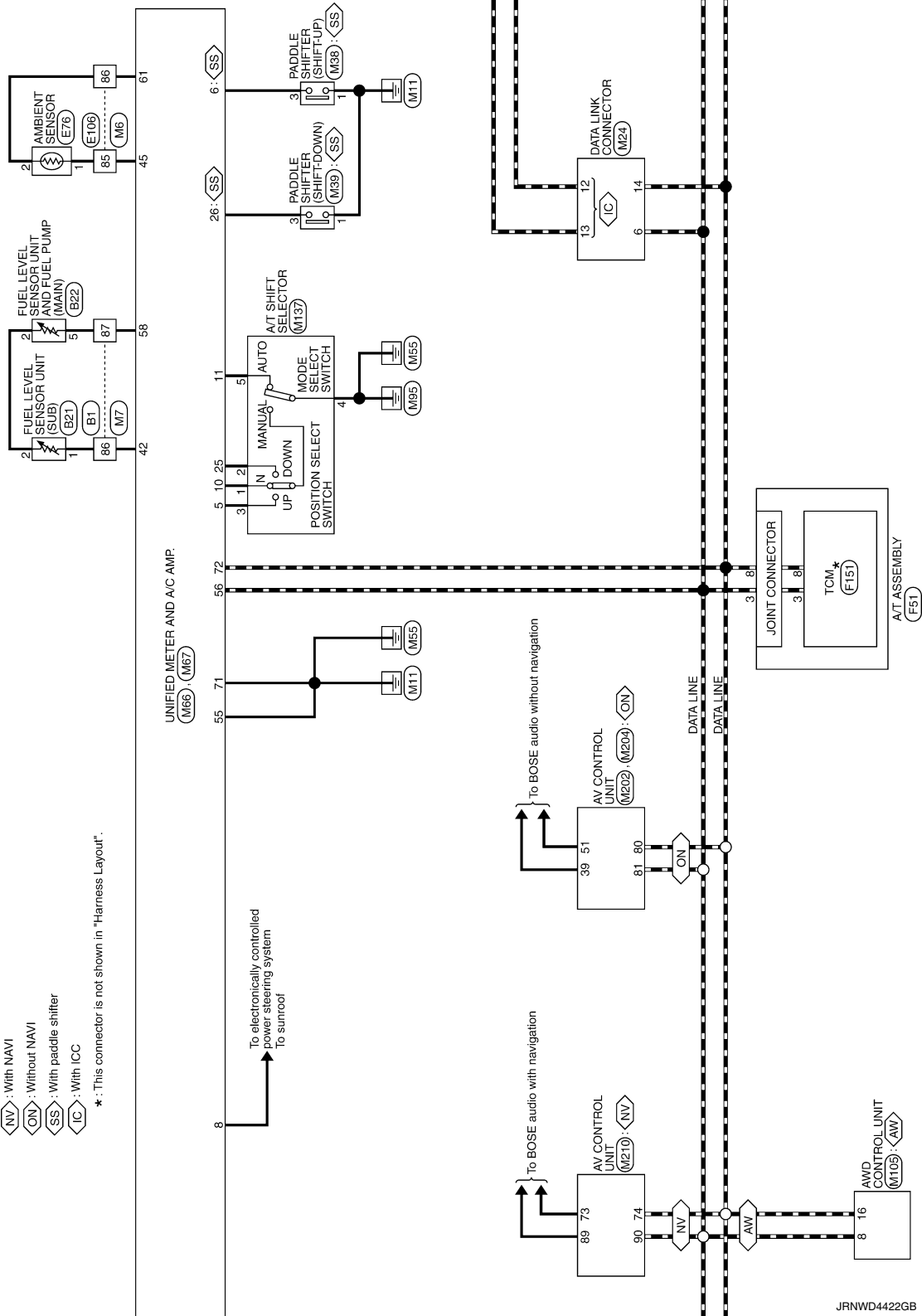

JRNWD4422GB

UNIFIED METER AND A/C AMP.

< ECU DIAGNOSIS INFORMATION >

- : With VQ engine
- : With YK engine
- : With ICC

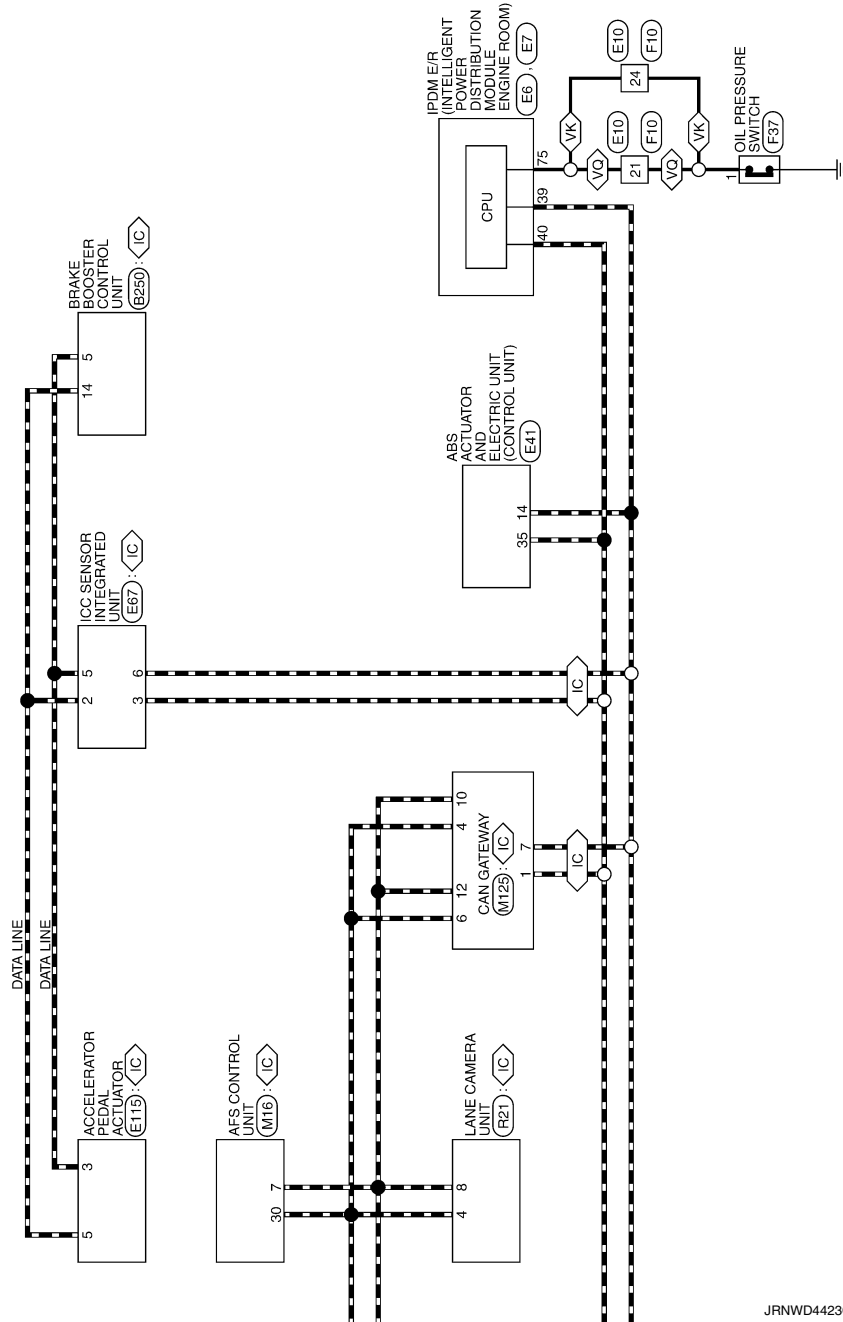

JRNWD4423GB

A
B
C
D
E
F
G
H
I
J
K
L
M
N
O
P

MWI

UNIFIED METER AND A/C AMP.

< ECU DIAGNOSIS INFORMATION >

METER

Connector No.	B1
Connector Name	WIRE TO WIRE
Connector Type	TH80FW-CS16-TM4



Terminal No.	Color Of Wire	Signal Name [Specification]
1	G	-
2	L	-
3	W	-
4	G	-
7	P	-
8	BG	-
10	SB	-
11	SB	-
12	B	-
13	G	-
14	R	-
15	W	-
16	SHIELD	-
17	L	-
18	P	-
19	G	-
20	Y	-
21	W	-
23	V	-
24	P	-
25	BR	-
26	GR	-
27	BG	-
28	W	-
38	B	-
39	B	-
43	SB	-
44	V	-
45	GR	-
51	V	-
52	SB	-
53	SHIELD	-
54	BR	-
55	Y	-
56	SHIELD	-

57	P	-
58	L	-
59	SHIELD	-
60	L	-
61	P	-
62	GR	-
63	G	-
64	BG	-
65	W	-
66	V	-
67	LG	-
68	Y	-
69	G	-
70	GR	-
71	G	-
72	B	-
73	W	-
74	V	-
75	BG	-
76	LG	-
77	L	-
78	GR	-
79	W	-
80	L	-
81	P	-
82	L	-
83	P	-
84	SB	-
85	R	-
86	Y	-
87	B	-
88	G	-
89	BR	-
91	R	-
92	BG	-
93	BR	-
94	V	-
96	BG	-
97	W	-
98	GR	-
99	W	-

Connector No.	B21
Connector Name	FUEL LEVEL SENSOR UNIT (SUB)
Connector Type	E02FGY-RS



Terminal No.	Color Of Wire	Signal Name [Specification]
1	Y	-
2	W	-

Connector No.	B22
Connector Name	FUEL LEVEL SENSOR UNIT AND FUEL PUMP (MAIN)
Connector Type	E05FGY-RS

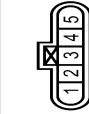

Terminal No.	Color Of Wire	Signal Name [Specification]
1	BR	- [With VK engine]
1	GR	- [With EVAP and VQ engine]
1	L	- [Without EVAP and VQ engine]
2	W	-
3	B	- [Without EVAP and VQ engine]
3	G	- [With VK engine]
3	GY	- [With EVAP and VQ engine]
4	R	-
5	B	-

Connector No.	B58
Connector Name	WIRE TO WIRE
Connector Type	NS10FM-CS

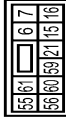

Terminal No.	Color Of Wire	Signal Name [Specification]
6	V	-
7	GR	-
15	BR	-
16	P	-
21	BG	-
55	G	-
56	L	-
59	LG	-
60	B	-
61	SB	-

Connector No.	B250
Connector Name	BRAKE BOOSTER CONTROL UNIT
Connector Type	TK24FW

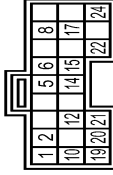

Terminal No.	Color Of Wire	Signal Name [Specification]
1	W	BATTERY
2	W	BATTERY
5	P	ITS COMM1
6	SB	RELEASE SW PWR
8	R	BRAKE PRESSURE SEN PWR
10	G	BOOSTER SOL GND
12	R	BOOSTER SOL GND
14	L	ITS COMM1
15	V	RELEASE SW (NC)

UNIFIED METER AND A/C AMP.

< ECU DIAGNOSIS INFORMATION >

METER

Terminal No.	Color Of Wire	Signal Name [Specification]
17	G	BRAKE PRESSURE SEN SIGNAL
19	B	GROUND
20	B	GROUND
21	GR	CHIME SIGNAL
22	BR	RELEASE SW (NO)
24	BG	BRAKE PRESSURE SEN GND

Connector No.	B501
Connector Name	WIRE TO WIRE
Connector Type	NS10MW-CS

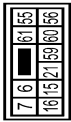

Terminal No.	Color Of Wire	Signal Name [Specification]
6	R	-
7	L	-
15	W	-
16	G	-
21	P	-
55	W	-
56	B	-
59	L/Y	-
60	R/Y	-
61	B/Y	-

Connector No.	B503
Connector Name	SEAT BELT BUCKLE SWITCH (DRIVER SIDE)
Connector Type	A03FW

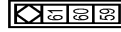

Terminal No.	Color Of Wire	Signal Name [Specification]
59	R	-
60	R/Y	-
61	B/Y	-

Connector No.	E6
Connector Name	POWER INTELLIGENT POWER DISTRIBUTION MODULE (ENGINE ROOM)
Connector Type	TH08FW-AH



Terminal No.	Color Of Wire	Signal Name [Specification]
39	P	-
40	L	-
41	B	-
42	Y	-
43	SB	-
44	W	-
45	G	-
46	BR	-

Connector No.	E7
Connector Name	POWER INTELLIGENT POWER DISTRIBUTION MODULE (ENGINE ROOM)
Connector Type	TH20FW-CS12-M4

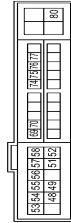

Terminal No.	Color Of Wire	Signal Name [Specification]
48	L	-
49	SB	- [With VQ engine]
49	W	- [With VK engine]
51	G	-
52	W	-

53	W	-
54	R	-
55	BR	-
56	BG	- [With VK engine]
57	V	- [With VQ engine]
57	LG	-
58	Y	-
59	W	-
70	BG	-
74	G	-
75	Y	-
76	P	- [With VK engine]
76	V	- [With VQ engine]
77	B	- [With VK engine]
77	L	- [With VQ engine]
80	W	-

Connector No.	E10
Connector Name	WIRE TO WIRE
Connector Type	SA036MB-RSS-SH28

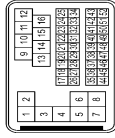

Terminal No.	Color Of Wire	Signal Name [Specification]
1	G	- [With VQ engine]
1	SHIELD	- [With VK engine]
2	L	- [With VQ engine]
2	SHIELD	- [With VK engine]
3	BR	- [With VQ engine]
3	G	- [With VK engine]
4	BR	- [With VQ engine]
4	SHIELD	- [With VK engine]
5	BR	- [With VQ engine]
5	G	- [With VK engine]
6	BR	- [With VQ engine]
6	R	- [With VK engine]
7	C	- [With VQ engine]
7	W	- [With VK engine]
8	SHIELD	- [With VQ engine]
8	W	- [With VK engine]
9	W	-
10	G	- [With VQ engine]

10	W	- [With VK engine]
11	R	- [With VQ engine]
11	W	- [With VK engine]
12	BR	- [With VQ engine]
12	W	- [With VK engine]
13	L	- [With VQ engine]
13	R	- [With VK engine]
14	LG	-
15	BG	- [With VK engine]
15	BR	- [With VQ engine]
16	V	- [With VK engine]
16	W	- [With VQ engine]
17	P	-
18	W	-
19	W	-
20	BR	-
21	SP	- [With VK engine]
21	Y	- [With VQ engine]
22	G	- [With VQ engine]
22	W	- [With VK engine]
23	R	- [With VQ engine]
23	V	- [With VK engine]
24	G	- [With VQ engine]
24	Y	- [With VK engine]
25	LG	-
26	LG	-
27	G	- [With VK engine]
27	GR	- [With VQ engine]
28	GR	- [With VK engine]
28	V	- [With VQ engine]
29	P	-
30	L	- [With VQ engine]
30	W	- [With VK engine]
31	G	- [With VK engine]
31	W	- [With VQ engine]
32	L	- [With VK engine]
32	V	- [With VQ engine]
33	BG	- [With VK engine]
33	W	- [With VQ engine]
34	BG	-
35	R	-
36	SHIELD	-
37	SHIELD	- [With VQ engine]
37	Y	- [With VK engine]
38	L	- [With VQ engine]
38	SHIELD	- [With VK engine]
39	P	- [With VQ engine]
39	W	- [With VK engine]
40	R	- [With VQ engine]
40	SHIELD	- [With VK engine]

A
B
C
D
E
F
G
H
I
J
K
L
M
MWI
O
P

UNIFIED METER AND A/C AMP.

< ECU DIAGNOSIS INFORMATION >

METER

41	W	- [With VQ engine]
41	Y	- [With VK engine]
42	LG	- [With VQ engine]
42	SHIELD	- [With VK engine]
43	G	- [With VQ engine]
43	W	- [With VK engine]
44	G	-
45	L	-
46	SHIELD	- [With VQ engine]
46	SHIELD	- [With VK engine]
47	B	- [With VQ engine]
47	W	- [With VK engine]
48	BR	- [With VQ engine]
48	R	- [With VK engine]
49	G	- [With VQ engine]
49	L	- [With VK engine]
50	B	- [With VQ engine]
50	G	- [With VK engine]
51	D	- [With VQ engine]
51	SB	- [With VK engine]
52	R	-

Connector No.	E41
Connector Name	ABS ACTUATOR AND ELECTRIC UNIT (CONTROL UNIT)
Connector Type	BAA42FB-AH2-LH

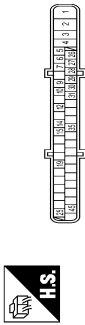

Terminal No.	Color Of Wire	Signal Name [Specification]
1	B	GROUND
2	G	LEAVR
3	R	LEAVR
4	B	GROUND
5	Y	DS FL
6	BG	DP RL
7	BR	DP RR
8	B	DP FR
9	B	DP PR
10	W	DS FR
12	L	VAC
14	P	CANL
15	SHIELD	AGND
19	P	UST
25	Y	BUS-L
26	R	DP FL
27	GR	DS RL
28	G	LZ
29	LG	DS RR
30	SB	BLS
31	R	VDC OFF SW
35	L	CAN-H
45	B	BUS-H

Connector No.	E32
Connector Name	WASHER LEVEL SWITCH
Connector Type	202FBR



Terminal No.	Color Of Wire	Signal Name [Specification]
1	LG	-
2	BW	-

Connector No.	E47
Connector Name	BRAKE FLUID LEVEL SWITCH
Connector Type	YV02FGY

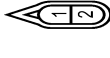

Terminal No.	Color Of Wire	Signal Name [Specification]
1	R	-
2	B	-

Connector No.	E67
Connector Name	ICC SENSOR INTEGRATED UNIT
Connector Type	RS06FB-PR



Terminal No.	Color Of Wire	Signal Name [Specification]
1	R	IGNITION
2	L	ITS COMM-H
3	L	CAN-H
4	B	GROUND
5	P	ITS COMM-L
6	P	CAN-L

Connector No.	E76
Connector Name	AMBIENT SENSOR
Connector Type	RS02FB



Terminal No.	Color Of Wire	Signal Name [Specification]
1	G	-
2	P	-

Connector No.	E106
Connector Name	WIRE TO WIRE
Connector Type	TH60FW-CS16-TM4

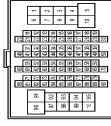

Terminal No.	Color Of Wire	Signal Name [Specification]
1	G	-
2	BG	-
3	SB	-
4	LG	-
5	Y	-
6	W	-
7	G	-
8	V	-
9	R	-
10	BR	-
11	B	-
12	G	-
13	R	-
14	W	-
15	SHIELD	-
16	SB	-
17	L	-
18	P	-

UNIFIED METER AND A/C AMP.

< ECU DIAGNOSIS INFORMATION >

METER

19	G	-	-	-	-
20	W	-	-	-	- [With ICC]
21	Y	-	-	-	- [Without ICC]
22	BR	L	-	-	- [With ICC]
23	R	W	-	-	- [Without ICC]
24	V	LG	-	-	- [With ICC]
25	G	GR	-	-	- [Without ICC]
26	L	P	-	-	- [With ICC]
27	L	W	-	-	- [Without ICC]
28	Y	-	-	-	- [With ICC]
29	G	BR	LG	-	-
30	LG	BR	-	-	-
31	BG	BR	-	-	-
32	W	SB	-	-	-
33	Y	-	-	-	-
34	BG	W	-	-	-
37	Y	-	-	-	-
38	GR	-	-	-	-
39	LG	-	-	-	-
41	LG	-	-	-	-
42	V	-	-	-	-
43	R	-	-	-	-
44	G	-	-	-	-
45	GR	-	-	-	-
46	W	-	-	-	-
47	L	-	-	-	-
48	P	-	-	-	-
49	SB	-	-	-	-
50	BR	-	-	-	-
51	B	-	-	-	-
52	Y	-	-	-	-
53	BG	-	-	-	-
54	R	-	-	-	-
55	SB	-	-	-	-
59	P	-	-	-	-
60	SB	-	-	-	-
61	V	-	-	-	-
62	P	-	-	-	-
63	LG	-	-	-	-
64	L	-	-	-	-
65	BG	-	-	-	-
69	L	-	-	-	-
70	SHIELD	-	-	-	-
71	G	-	-	-	-
72	G	-	-	-	-
73	R	-	-	-	-
74	BR	-	-	-	-
76	L	-	-	-	-

77	W	-	-	-	-
78	Y	-	-	-	-
80	SB	-	-	-	-
81	L	-	-	-	-
82	W	-	-	-	-
83	LG	-	-	-	-
84	GR	-	-	-	-
85	G	-	-	-	-
86	P	-	-	-	-
87	W	-	-	-	-
88	BG	-	-	-	-
89	LG	-	-	-	-
90	BR	-	-	-	-
91	GR	-	-	-	-
92	BR	-	-	-	-
93	SB	-	-	-	-
95	Y	-	-	-	-
96	W	-	-	-	-
97	W	-	-	-	-
98	SHIELD	-	-	-	-
100	Y	-	-	-	-

Connector No.	E107
Connector Name	PARKING BRAKE SWITCH
Connector Type	TBD1FW



Terminal No.	1
Color Of Wire	LG
Signal Name [Specification]	-

Connector No.	E115
Connector Name	ACCELERATOR PEDAL ACTUATOR
Connector Type	KDZ06FB



Terminal No.	Color Of Wire	Signal Name [Specification]
1	R	IGNITION
2	BG	BATTERY
3	P	ITS COM+L
4	B	GROUND
5	L	ITS COM+H

Connector No.	F10
Connector Name	WIRE TO WIRE
Connector Type	SAAG3FB-RS9-SH28

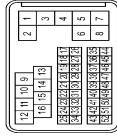

Terminal No.	Color Of Wire	Signal Name [Specification]
1	G	- [With VQ engine]
2	SHIELD	- [With VK engine]
3	BR	- [With VQ engine]
4	SHIELD	- [With VK engine]
5	BR	- [With VQ engine]
6	BR	- [With VK engine]
7	W	- [With VQ engine]
8	SHIELD	- [With VK engine]

8	W	-	-	-	- [With VQ engine]
9	W	-	-	-	-
10	G	-	-	-	-
11	R	-	-	-	- [With VK engine]
12	P	-	-	-	- [With VQ engine]
13	V	-	-	-	- [With VK engine]
14	L	-	-	-	- [With VQ engine]
15	O	-	-	-	- [With VK engine]
16	R	-	-	-	- [With VQ engine]
17	GR	-	-	-	- [With VK engine]
18	G	-	-	-	-
19	O	-	-	-	-
20	R	-	-	-	-
21	V	-	-	-	- [With VK engine]
22	B	-	-	-	- [With VQ engine]
23	LG	-	-	-	- [With VK engine]
24	LG	-	-	-	- [With VQ engine]
25	V	-	-	-	- [With VK engine]
26	O	-	-	-	-
27	GR	-	-	-	- [With VQ engine]
28	BR	-	-	-	- [With VK engine]
29	L	-	-	-	- [With VQ engine]
30	GR	-	-	-	- [With VK engine]
31	BR	-	-	-	- [With VQ engine]
32	G	-	-	-	- [With VK engine]
33	L	-	-	-	- [With VQ engine]
34	O	-	-	-	- [With VK engine]
35	P	-	-	-	-
36	SHIELD	-	-	-	-
37	SHIELD	-	-	-	- [With VQ engine]
38	SHIELD	-	-	-	- [With VK engine]

A
B
C
D
E
F
G
H
I
J
K
L
M
N
O
P

MWI

UNIFIED METER AND A/C AMP.

< ECU DIAGNOSIS INFORMATION >

Terminal No.	Color	Wire	Signal Name [Specification]
39	W	-	- [With VK engine]
39	Y	-	- [With VQ engine]
40	G	-	- [With VQ engine]
40	SHIELD	-	- [With VK engine]
41	B	-	- [With VQ engine]
41	Y	-	- [With VK engine]
42	GR	-	- [With VQ engine]
42	SHIELD	-	- [With VK engine]
43	R	-	- [With VQ engine]
43	W	-	- [With VK engine]
44	LG	-	-
45	L	-	-
46	G	-	- [With VK engine]
46	SHIELD	-	- [With VQ engine]
47	B	-	- [With VK engine]
47	W	-	- [With VQ engine]
48	LG	-	- [With VK engine]
48	R	-	- [With VQ engine]
49	G	-	- [With VK engine]
49	L	-	- [With VQ engine]
50	B	-	- [With VQ engine]
50	G	-	- [With VK engine]
51	B	-	- [With VK engine]
51	W	-	- [With VQ engine]
52	R	-	-

Terminal No.	Color	Wire	Signal Name [Specification]
1	Y	-	-

Terminal No.	Color	Wire	Signal Name [Specification]
1	W	-	IGNITION POWER SUPPLY
2	B	-	BATTERY POWER SUPPLY (MEMORY BACK-UP)
3	R	-	CAN-H
4	O	-	K-LINE
5	G	-	GROUND
6	GR	-	IGNITION POWER SUPPLY
7	L	-	BACK-UP LAMP RELAY
8	BR	-	CAN-L
9	Y	-	STARTER RELAY
10	W/B	-	GROUND

Terminal No.	Color	Wire	Signal Name [Specification]
1	G	-	-
2	W	-	-
3	GR	-	- [With VK engine]
4	R	-	- [With VQ engine]
5	B	-	- [With VQ engine]
6	R	-	- [With VK engine]
7	B	-	- [With VK engine]
8	W	-	- [With VK engine]
9	Y	-	- [With VQ engine]
10	GR	-	- [With VQ engine]
10	L	-	- [With VK engine]
19	O	-	-
20	Y	-	-
27	L	-	-
28	B	-	-
29	LG	-	-
31	R	-	-
34	LG	-	-
35	BR	-	-
36	W	-	-
37	Y	-	-
38	P	-	-
44	L	-	-
45	Y	-	-
46	V	-	-

Terminal No.	Color	Wire	Signal Name [Specification]
1	Y	-	IGNITION POWER SUPPLY
2	R	-	BATTERY POWER SUPPLY (MEMORY BACK-UP)
3	L	-	CAN-H
4	V	-	K-LINE
5	B	-	GROUND
6	Y	-	IGNITION POWER SUPPLY
7	R	-	BACK-UP LAMP RELAY
8	P	-	CAN-L
9	GR	-	STARTER RELAY [With VQ engine]
9	LG	-	STARTER RELAY [With VK engine]
10	B	-	GROUND

Terminal No.	Color	Wire	Signal Name [Specification]
2	G	-	L
3	O	-	S [With VK engine]
3	V	-	S [With VQ engine]
4	P	-	C [With VK engine]
4	W	-	C [With VQ engine]

Terminal No.	Color	Wire	Signal Name [Specification]
1	W	-	IGNITION POWER SUPPLY
2	B	-	BATTERY POWER SUPPLY (MEMORY BACK-UP)
3	R	-	CAN-H
4	O	-	K-LINE
5	G	-	GROUND
6	GR	-	IGNITION POWER SUPPLY
7	L	-	BACK-UP LAMP RELAY
8	BR	-	CAN-L
9	Y	-	STARTER RELAY [With VQ engine]
9	LG	-	STARTER RELAY [With VK engine]
10	B	-	GROUND

Terminal No.	Color	Wire	Signal Name [Specification]
1	W	-	IGNITION POWER SUPPLY
2	B	-	BATTERY POWER SUPPLY (MEMORY BACK-UP)
3	R	-	CAN-H
4	O	-	K-LINE
5	G	-	GROUND
6	GR	-	IGNITION POWER SUPPLY
7	L	-	BACK-UP LAMP RELAY
8	BR	-	CAN-L
9	Y	-	STARTER RELAY
10	W/B	-	GROUND

JRNWD4428GB

UNIFIED METER AND A/C AMP.

< ECU DIAGNOSIS INFORMATION >

METER

Connector No.	M2
Connector Name	FUSE BLOCK (J/B)
Connector Type	NS10FM-CS

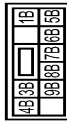

Terminal No.	Color Of Wire	Signal Name [Specification]
1B	LG	-
3B	P	-
4B	G	-
5B	BG	-
7B	Y	-
8B	R	-
9B	BR	-

Connector No.	M3
Connector Name	FUSE BLOCK (J/B)
Connector Type	NS12FM-CS

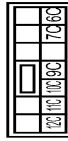

Terminal No.	Color Of Wire	Signal Name [Specification]
10C	L	-
11C	LG	-
12C	R	-
7C	B	-
9C	BG	-

Connector No.	M6
Connector Name	WIRE TO WIRE
Connector Type	TH80MW-CS16-TM4

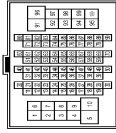

Terminal No.	Color Of Wire	Signal Name [Specification]
1	G	-
2	BG	-
3	LG	- [Without Auto aircon seat]
4	SB	- [With Auto aircon seat]
5	GR	-
6	W	-
7	G	-
8	W	-
9	P	-
10	BR	-
11	B	-
12	G	-
13	R	-
14	W	-
15	SHIELD	-
16	BR	-
17	L	-
18	P	-
19	G	-
20	GR	- [Without ICC]
21	BR	- [With ICC]
22	L	- [Without ICC]
23	R	- [With ICC]
24	L	-
25	W	- [Without ICC]
26	W	- [With ICC]
27	Y	- [Without ICC]
28	SHIELD	- [With ICC]
29	GR	-
30	BG	-
32	W	-

33	Y	-
34	L	-
37	G	-
38	R	-
39	G	-
41	L	-
42	W	-
43	R	-
44	LG	-
45	GR	-
46	W	-
47	L	-
48	P	-
49	BG	-
50	LG	-
51	SB	-
52	Y	-
53	BG	-
54	BR	-
55	SB	-
59	SB	-
60	SB	-
61	V	-
62	P	-
63	R	-
64	L	-
65	BG	-
69	V	-
70	SHIELD	-
71	BG	-
72	GR	-
73	W	-
74	SB	-
76	V	-
77	V	-
78	Y	-
80	BG	-
81	L	-
82	W	-
83	Y	-
84	L	-
85	P	-
86	BR	-
87	P	-
88	V	-
89	G	-
90	P	-
91	R	-
92	R	-
93	GR	-

95	G	-
96	W	-
97	W	-
98	SHIELD	-
100	Y	-

Connector No.	M7
Connector Name	WIRE TO WIRE
Connector Type	TH80MW-CS16-TM4

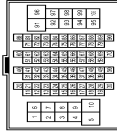

Terminal No.	Color Of Wire	Signal Name [Specification]
1	G	- [With Auto aircon seat]
1	Y	- [Without Auto aircon seat]
2	B	-
3	W	-
6	P	-
7	V	-
8	BG	-
10	W	-
11	BG	-
12	B	-
13	G	-
14	R	-
15	W	-
16	SHIELD	-
17	L	-
18	P	-
19	G	-
20	R	-
21	LG	-
23	V	-
24	P	-
25	BR	-
26	GR	-
27	BG	-
28	W	-
38	B	-
39	B	-
43	SB	-
44	W	-

A
B
C
D
E
F
G
H
I
J
K
L
M
MWI
O
P

UNIFIED METER AND A/C AMP.

< ECU DIAGNOSIS INFORMATION >

METER		M16		M24		M39	
Terminal No.	Color Of Wire	Signal Name [Specification]	Terminal No.	Color Of Wire	Signal Name [Specification]	Terminal No.	Color Of Wire
45	B	-	3	LG	-	1	BG
51	V	-	4	B	-	2	LG
52	LG	-	5	B	-	3	GR
53	SHIELD	-	6	W	-	5	B
54	BR	-	7	GR	-	6	W
55	Y	-	8	G	-	7	P
56	SHIELD	-	9	GR	-	10	G
57	P	-	11	SB	-	15	B
58	L	-	12	P	-	16	B
59	SHIELD	-	13	L	-	21	R
60	L	-	14	P	-	24	BR
61	BR	-	16	BG	-	25	Y
62	R	-	17	W	-	26	R
63	Y	-	19	SB	-	27	V
64	L	-	24	V	-	28	W
65	W	-	25	B	-	29	W
66	V	-	27	BR	-	30	SB
67	LG	-	28	SB	-	30	G
68	Y	-	29	BG	-	31	L
69	G	-	30	L	-	-	-
70	V	-	32	G	-	-	-
71	W	-	34	W	-	-	-
72	B	-	36	R	-	-	-
73	W	-	38	B	-	-	-
74	LG	-	40	BG	-	-	-
75	P	-	-	-	-	-	-
76	LG	-	-	-	-	-	-
77	SB	-	-	-	-	-	-
78	GR	-	-	-	-	-	-
79	R	-	-	-	-	-	-
80	L	-	-	-	-	-	-
81	P	-	-	-	-	-	-
82	L	-	-	-	-	-	-
83	P	-	-	-	-	-	-
84	SB	-	-	-	-	-	-
85	W	-	-	-	-	-	-
86	Y	-	-	-	-	-	-
87	B	-	-	-	-	-	-
88	G	-	-	-	-	-	-
89	BG	-	-	-	-	-	-
91	R	-	-	-	-	-	-
92	BG	-	-	-	-	-	-
93	BR	-	-	-	-	-	-
94	V	-	-	-	-	-	-
96	BG	-	-	-	-	-	-
97	W	-	-	-	-	-	-
98	R	-	-	-	-	-	-
99	BG	-	-	-	-	-	-

Terminal No.	Color Of Wire	Signal Name [Specification]
1	Y	IGN
2	LG	PSG-R
4	Y	PSG-R
6	W	HSV-R
7	P	CAN-L
8	B	HSG-R
9	GR	PSR
11	R	SMR-1 (-)
13	B	SMR-2 (-)
15	G	SML-1 (+)
17	W	SML-2 (+)
19	SB	AMDS-R
24	V	PSV-L
25	B	GROUND
27	BR	PSG-L
28	SB	HSR
29	BG	PS-L
30	L	CAN-H
32	G	SMR-2 (+)
34	W	SMR-1 (+)
36	R	SML-2 (-)
38	B	SML-1 (-)
40	BG	AMDS-L

Terminal No.	Color Of Wire	Signal Name [Specification]
3	LG	-
4	B	-
5	B	-
6	L	-
7	GR	-
8	G	-
11	SB	-
12	P	-
13	L	-
14	P	-
16	BG	-

Terminal No.	Color Of Wire	Signal Name [Specification]
1	BG	BATTERY POWER SUPPLY
2	LG	COMMUNICATION SIGNAL (METER->AMP)
3	GR	COMMUNICATION SIGNAL (AMP->METER)
5	B	GROUND
6	W	ALTERNATOR SIGNAL
7	P	AIR BAG SIGNAL
10	G	SECURITY INDICATOR SIGNAL
15	B	GROUND
16	B	METER CONTROL SWITCH GROUND
21	R	IGNITION SIGNAL
24	BR	COMMUNICATION SIGNAL (LCD->AMP)
25	Y	COMMUNICATION SIGNAL (AMP->LCD)
26	R	VEHICLE SPEED SIGNAL (8-PULSE)
27	V	PARKING BRAKE SWITCH SIGNAL
28	W	BRAKE FLUID LEVEL SWITCH SIGNAL
29	SB	SEAT BELT SWITCH SIGNAL (LOWER SIDE)
30	G	PASSENGER SEAT BELT WARNING SIGNAL
31	L	WASHER LEVEL SWITCH SIGNAL

Terminal No.	Color Of Wire	Signal Name [Specification]
1	B	-
3	BG	-

Terminal No.	Color Of Wire	Signal Name [Specification]
1	B	-
3	BG	-

JRNWD4430GB

UNIFIED METER AND A/C AMP.

< ECU DIAGNOSIS INFORMATION >

METER

34	B	ILLUMINATION CONTROL SIGNAL
36	LG	SELECT SWITCH SIGNAL
37	SB	ENTER SWITCH SIGNAL
38	L	TRIP A/B RESET SWITCH SIGNAL
39	P	ILLUMINATION CONTROL SWITCH SIGNAL (-)
40	BG	ILLUMINATION CONTROL SWITCH SIGNAL (+)

Connector No.	M54
Connector Name	METER CONTROL SWITCH
Connector Type	TH12MW-NH



Terminal No.	Color Of Wire	Signal Name [Specification]
1	BG	-
2	B	-
3	P	-
4	R	-
5	B	-
6	LG	-
7	SB	-

Connector No.	M56
Connector Name	TRIP A/B RESET SWITCH
Connector Type	TH04MW-NH

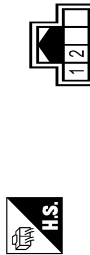

Terminal No.	Color Of Wire	Signal Name [Specification]
1	L	-
2	B	-

Connector No.	M66
Connector Name	UNIFIED METER AND A/C AMP.
Connector Type	TH01FW-NH

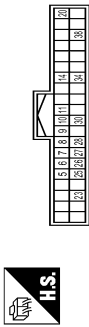

Terminal No.	Color Of Wire	Signal Name [Specification]
5	L	MANUAL MODE SHIFT UP SIGNAL
6	BG	PADDLE SHIFTER UP SIGNAL
7	GR	COMMUNICATION SIGNAL (AMP->METER)
8	L	VEHICLE SPEED SIGNAL (2-PULSE)
9	SB	SEAT BELT BRACKE SWITCH SIGNAL (DRIVER SIDE)
10	W	MANUAL MODE SIGNAL
11	G	NONMANUAL MODE SIGNAL
14	BR	COMMUNICATION SIGNAL (LCD->AMP)
20	L	ION SENSOR SIGNAL
23	Y	AT SNOW SWITCH SIGNAL
25	V	MANUAL MODE SHIFT DOWN SIGNAL
26	G	PADDLE SHIFTER DOWN SIGNAL
27	LG	COMMUNICATION SIGNAL (METER->AMP)
28	R	VEHICLE SPEED SIGNAL (8-PULSE)
30	V	PARKING BRAKE SWITCH SIGNAL
34	Y	COMMUNICATION SIGNAL (AMP->LCD)
38	L	BLOWER MOTOR CONTROL SIGNAL

Connector No.	M67
Connector Name	UNIFIED METER AND A/C AMP.
Connector Type	TH02FW-NH

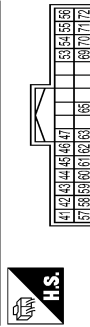

Terminal No.	Color Of Wire	Signal Name [Specification]
41	V	ACC POWER SUPPLY
42	Y	FUEL LEVEL SENSOR SIGNAL
43	R	INTAKE SENSOR SIGNAL

44	LG	IN-VEHICLE SENSOR SIGNAL
45	P	AMBIENT SENSOR SIGNAL
46	BG	SUNLOAD SENSOR SIGNAL
47	V	GAS SENSOR SIGNAL
53	G	IGNITION POWER SUPPLY
54	BG	BATTERY POWER SUPPLY
55	B	GROUND
56	L	CANH
57	W	BRAKE FLUID LEVEL SWITCH SIGNAL
58	B	FUEL LEVEL SENSOR GROUND
59	GR	INTAKE SENSOR GROUND
60	L	IN-VEHICLE SENSOR GROUND
61	BR	AMBIENT SENSOR GROUND
62	SB	SUNLOAD SENSOR GROUND
63	R	IGN MODE SIGNAL
65	BG	ECV SIGNAL
69	L	A/C LAMP SIGNAL
70	R	EACH DOOR MOTOR POWER SUPPLY
71	B	GROUND
72	P	CANL

Connector No.	M105
Connector Name	AWD CONTROL UNIT
Connector Type	TH18FW-NH

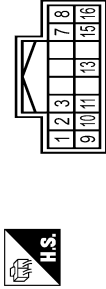

Terminal No.	Color Of Wire	Signal Name [Specification]
1	BR	AWD SOL (+)
2	Y	AWD SOL (-)
3	W	FLUID TEMP (-)
7	GR	IGN
8	L	CANH
9	BG	AWD SOL BAT
10	B	GROUND
11	B	GROUND
13	LG	FLUID TEMP (+)
15	Y	BATTERY
16	P	CANL

Connector No.	M116
Connector Name	WIRE TO WIRE
Connector Type	TK38MW-NS10

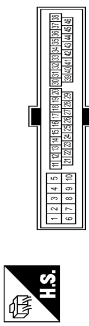

Terminal No.	Color Of Wire	Signal Name [Specification]
2	W	-
3	L	-
4	B	- [With VK engine]
4	R	- [With VO engine]
5	B	- [With VK engine]
5	R	- [With VO engine]
7	B	-
9	L	- [With VK engine]
9	R	- [With VO engine]
10	R	-
19	BG	-
20	Y	-
27	L	-
28	B	-
29	LG	-
31	W	-
34	LG	-
35	BR	-
36	W	-
37	Y	-
38	BG	-
43	P	-
44	L	-
45	G	-
46	Y	-

A
B
C
D
E
F
G
H
I
J
K
L
M
N
O
P

MWI

JRNWD4431GB

UNIFIED METER AND A/C AMP.

< ECU DIAGNOSIS INFORMATION >

METER

Connector No.	M122
Connector Name	BCM (BODY CONTROL MODULE)
Connector Type	TH40FB-NH



Terminal No.	Color Of Wire	Signal Name [Specification]
74	SB	PASSENGER DOOR ANT-
75	BR	PASSENGER DOOR ANT+
76	V	DRIVER DOOR ANT-
77	LG	DRIVER DOOR ANT+
78	Y	ROOM ANTI-
79	BR	ROOM ANTI+
80	GR	WATS ANT AMP.
81	W	WATS ANT AMP.
82	P	IGN RELAY (P/B) CONT
83	GR	KEYLESS ENTRY RECEIVER SIGNAL
87	BR	COMBI SW INPUT 5
88	V	COMBI SW INPUT 3
90	P	CANL
91	L	CANH
92	LG	KEY SLOT ILL
93	V	ON IND
95	BG	ACC RELAY CONT
96	GR	ANT SHIFT SELECTOR POWER SUPPLY
99	R	SHIFT P
100	G	PASSENGER DOOR REQUEST SW
101	SB	DRIVER DOOR REQUEST SW
102	BG	BLOWER FAN MOTOR RELAY CONT
103	BR	KEYLESS ENTRY RECEIVER POWER SUPPLY
107	LG	COMBI SW INPUT 1
108	R	COMBI SW INPUT 4
109	Y	COMBI SW INPUT 2
110	G	HAZARD SW

Connector No.	M123
Connector Name	BCM (BODY CONTROL MODULE)
Connector Type	TH40FG-NH

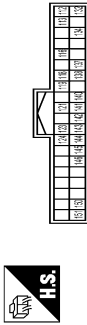

Terminal No.	Color Of Wire	Signal Name [Specification]
112	GR	RAIN SENSOR SERIAL LINK
113	P	OPTICAL SENSOR
116	BR	STOP LAMP SW 1
118	B	STOP LAMP SW 2
119	SB	DR DOOR UNLOCK SENSOR
121	BR	KEY SLOT SW
123	W	IGN P/B
124	LG	PASSENGER DOOR SW
132	BG	POWER WINDOW SW COM1
134	GR	LOCK IND
137	B	RECEIVER SENSOR GND
138	Y	SENSOR POWER SUPPLY
140	R	SHIFT N/P
141	G	SECURITY INDICATOR OUTPUT
142	BG	COMBI SW OUTPUT 5
143	P	COMBI SW OUTPUT 1
144	G	COMBI SW OUTPUT 2
145	L	COMBI SW OUTPUT 3
146	SB	COMBI SW OUTPUT 4
150	GR	DRIVER DOOR SW
151	G	REAR WINDOW DEFROGGER RELAY CONT

Connector No.	M125
Connector Name	CAN GATEWAY
Connector Type	TH12FM-NH



Terminal No.	Color Of Wire	Signal Name [Specification]
1	L	CANH
3	GR	BATTERY
4	L	CANH
5	B	GROUND
6	L	CANH
7	P	CANL
8	LG	IGNITION
10	P	CANL
11	B	GROUND
12	P	CANL

Connector No.	M137
Connector Name	AT SHIFT SELECTOR
Connector Type	TH12FM-NH



Terminal No.	Color Of Wire	Signal Name [Specification]
1	W	-
2	V	-
3	L	-
4	B	-
5	G	-
7	BG	-
8	SB	-
9	B	-
10	GR	-
11	R	-

Connector No.	M151
Connector Name	WIRE TO WIRE
Connector Type	M03FW-LC

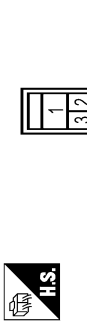

Terminal No.	Color Of Wire	Signal Name [Specification]
1	W	-
2	Y	-
3	R	-

Connector No.	M152
Connector Name	WIRE TO WIRE
Connector Type	M03MW-LC



Terminal No.	Color Of Wire	Signal Name [Specification]
1	W	-
2	Y	-
3	R	-

UNIFIED METER AND A/C AMP.

< ECU DIAGNOSIS INFORMATION >

METER

Connector No.	M160
Connector Name	ECM
Connector Type	RH24FGY-RZ8-LH-Z

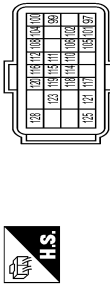

Terminal No.	Color	Wire	Signal Name [Specification]
97	R	R	ENGINE SPEED SIGNAL OUTPUT
98	G	G	SENSOR POWER SUPPLY
99	G	G	SENSOR POWER SUPPLY
100	P	P	CAN COMMUNICATION LINE
102	SB	SB	ASC/DC STEERING SWITCH
104	R	R	ACCELERATOR PEDAL POSITION SENSOR 1
105	L	L	CAN COMMUNICATION LINE
106	P	P	IGNITION SWITCH
110	P	P	STOP LAMP SWITCH
111	V	V	SENSOR GROUND
112	LG	LG	FUEL PUMP CONTROL MODULE (FFCM) CHECK
114	GR	GR	DATA LINK CONNECTOR
115	GR	GR	SENSOR GROUND
116	G	G	TRANSMISSION RANGE SWITCH
117	BR	BR	ASC/DC BRAKE SWITCH
118	R	R	POWER SUPPLY FOR ECM (BACK-UP)
119	W	W	SENSOR GROUND
120	W	W	FUEL TANK TEMPERATURE SENSOR
121	GR	GR	POWER SUPPLY FOR ECM
123	B	B	ECM GROUND
125	R	R	FUEL PUMP CONTROL MODULE (FFCM)
128	B	B	ECM GROUND

Connector No.	M164
Connector Name	ECM
Connector Type	RH24FGY-RZ8-LH-Z

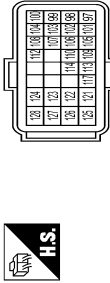

Terminal No.	Color	Wire	Signal Name [Specification]
97	R	R	ACCELERATOR PEDAL POSITION SENSOR 1
98	P	P	ACCELERATOR PEDAL POSITION SENSOR 2 (PULSE)
99	V	V	ACCELERATOR PEDAL POSITION SENSOR 2 (PULSE)
88	G	G	SENSOR POWER SUPPLY (With NAVI)
89	L	L	SENSOR POWER SUPPLY (Without NAVI)
100	W	W	SENSOR GROUND
101	SB	SB	ASC/DC STEERING SWITCH
102	LG	LG	EVAP CONTROL SYSTEM PRESSURE SENSOR
103	G	G	SENSOR POWER SUPPLY (Without NAVI)
104	L	L	SENSOR GROUND (With NAVI)
104	BR	BR	SENSOR GROUND (Without NAVI)
105	L	L	REFRIGERANT PRESSURE SENSOR
106	W	W	FUEL TANK TEMPERATURE SENSOR
107	BG	BG	SENSOR POWER SUPPLY
108	V	V	SENSOR GROUND
109	G	G	PNP SIGNAL
110	R	R	ENGINE SPEED OUTPUT SIGNAL
112	V	V	ENGINE GROUND (With NAVI CONTROL SYSTEM PRESSURE SENSOR)
113	P	P	CAN COMMUNICATION LINE
114	L	L	CAN COMMUNICATION LINE
117	GR	GR	DATA LINK CONNECTOR
121	LG	LG	EVAP CANISTER VENT CONTROL VALVE
122	P	P	STOP LAMP SWITCH
123	B	B	ECM GROUND
124	B	B	ECM GROUND
125	GR	GR	POWER SUPPLY FOR ECM
126	BR	BR	ASC/DC BRAKE SWITCH
127	B	B	ECM GROUND
128	B	B	ECM GROUND

Connector No.	M202
Connector Name	AV CONTROL UNIT
Connector Type	TH24FM-NH

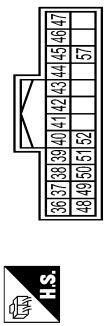

Terminal No.	Color	Wire	Signal Name [Specification]
36	BG	BG	SIGNAL VCC
37	LG	LG	SIGNAL GND
38	R	R	VP
39	BR	BR	COMM (DISP->CONT)
40	B	B	RGB AREA (VS) SIGNAL
41	SHIELD	SHIELD	SHIELD
42	G	G	RGB SYNC
43	B	B	RGB (R/RED) SIGNAL
44	W	W	RGB (G/GREEN) SIGNAL
45	R	R	RGB (B/BLUE) SIGNAL
46	BG	BG	COMPOSITE IMAGE SIGNAL GND
47	SB	SB	COMPOSITE IMAGE SIGNAL
48	Y	Y	INVERTER VCC
49	BR	BR	INVERTER GND
50	W	W	VP
51	Y	Y	COMM (CONT->DISP)
52	SB	SB	SHIELD
57	SHIELD	SHIELD	SHIELD

Connector No.	M204
Connector Name	AV CONTROL UNIT
Connector Type	TH24FM-NH

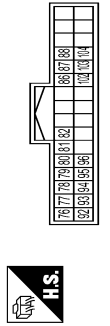

Terminal No.	Color	Wire	Signal Name [Specification]
76	LG	LG	AV COMM (L)
77	SB	SB	AV COMM (H)
78	LG	LG	AV COMM (L)
79	SB	SB	AV COMM (H)
80	P	P	CANL
81	L	L	CANH
82	BR	BR	SW GND
86	SHIELD	SHIELD	SHIELD
87	L	L	TEL VOICE SIGNAL (*)
88	P	P	TEL VOICE SIGNAL (L)
92	R	R	VEHICLE SPEED SIGNAL (8-PULSE)
93	V	V	PARKING BRAKE SIGNAL
94	BG	BG	REVERSE SIGNAL
95	G	G	IGNITION SIGNAL
96	SB	SB	DISK EJECT SIGNAL
102	B	B	AUX GND
103	W	W	AUX AUDIO L/H+
104	R	R	AUX AUDIO R/H+

Connector No.	M210
Connector Name	AV CONTROL UNIT
Connector Type	TH24FW-NH

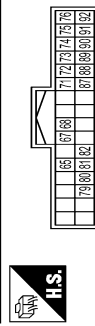

Terminal No.	Color	Wire	Signal Name [Specification]
65	V	V	PARKING BRAKE SIGNAL
67	B	B	COMPOSITE IMAGE SIGNAL GND
68	R	R	COMPOSITE IMAGE SIGNAL
71	SHIELD	SHIELD	MICROPHONE SHIELD
72	G	G	MICROPHONE VCC
73	R	R	COMM (CONT->DISP)
74	P	P	CANL
75	LG	LG	AV COMM (L)
76	LG	LG	AV COMM (L)
78	R	R	ILLUMINATION
80	G	G	IGNITION SIGNAL
81	BG	BG	REVERSE SIGNAL
82	R	R	VEHICLE SPEED SIGNAL (8-PULSE)
87	R	R	MICROPHONE SIGNAL

A
B
C
D
E
F
G
H
I
J
K
L
M
MWI
O
P

UNIFIED METER AND A/C AMP.

< ECU DIAGNOSIS INFORMATION >

METER		LANE CAMERA UNIT	
88	B	R21	
89	G	Connector Name	LANE CAMERA UNIT
90	L	Connector Type	TH98FM-NH
91	SB		
92	SB		

Terminal No.	Color Of Wire	Signal Name [Specification]
1	B	GROUND
2	SB	WARNING SYSTEMS ON INDICATOR
3	Y	WARNING SYSTEMS SWITCH
4	L	CANLH
5	B	GROUND
6	R	LANE DEPARTURE WARNING BUZZER
7	Y	IGNITION POWER SUPPLY
8	P	CANL

Terminal No.	Color Of Wire	Signal Name [Specification]
23	Y	INFLATOR AS2+
24	Y	INFLATOR AS2-
25	Y	INFLATOR AS1-
26	Y	INFLATOR AS1+
27	B	GND
28	Y	INFLATOR DR2+
29	Y	INFLATOR DR1+3DR2-
30	Y	INFLATOR DR+
31	V	ECZS-
32	BR	SIDE SENS RH2-
34	G	SIDE SENS LH2-
35	P	A/B W/L
38	G	SEATBELT W/L
39	SHIELD	GND
41	SB	ECZS+
42	Y	SIDE SENS RH2+
44	R	SIDE SENS LH2+
45	P	CAN LO
46	L	CAN HI
47	P	A/B CUTOFF TELLTALE
50	LG	IGN

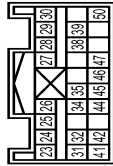
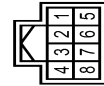

Fail-Safe

FAIL-SAFE

The unified meter and A/C amp. activates the fail-safe control if CAN communication with each unit is malfunctioning.

JRNWD4434GB

INFOID:000000010577087

UNIFIED METER AND A/C AMP.

< ECU DIAGNOSIS INFORMATION >

Function	Specifications		
Speedometer	Reset to zero by suspending communication.		
Tachometer			
Fuel gauge			
Engine coolant temperature gauge			
Illumination control	When suspending communication, change to nighttime mode.		
Information display	The display turns off by suspending communication.		
Buzzer	The buzzer turns off by suspending communication.		
Warning lamp/indicator lamp	ABS warning lamp	The lamp turns on by suspending communication.	
	VDC OFF indicator lamp		
	Brake warning lamp		
	CRUISE warning lamp		
	IBA OFF indicator lamp		
	AWD warning lamp		
	Low tire pressure warning lamp		
	Master warning lamp	The lamp turns off by suspending communication.	
	Malfunction indicator lamp		
	AFS OFF indicator lamp		The lamp blinking caused by communication malfunction
	High beam indicator		The lamp turns off by suspending communication.
	Turn signal indicator lamp		
	Tail lamp indicator lamp		
	VDC warning lamp		
	Oil pressure warning lamp		
	A/T CHECK warning lamp		
Key warning lamp			
Lane departure warning lamp			
LDP ON indicator lamp			

DTC Index

INFOID:000000010577088

Display contents of CONSULT	Time	Diagnostic item is detected when ...	Refer to
CAN COMM CIRCUIT [U1000]	CRNT, 1 - 39	When unified meter and A/C amp. is not transmitting or receiving CAN communication signal for 2 seconds or more.	MWI-49
CONTROL UNIT (CAN) [U1010]	CRNT, 1 - 39	When detecting error during the initial diagnosis of CAN controller of unified meter and A/C amp.	MWI-50
COMM ERROR 1 [B2201]	CRNT, 1 - 39	If a communication error is present in the communication line between unified meter and A/C amp. and combination meter for 2 seconds or more.	MWI-51
COMM ERROR 2 [B2202]	CRNT, 1 - 39	If a communication error is present in the communication line between unified meter and A/C amp. and combination meter for 2 seconds or more.	MWI-53
VEHICLE SPEED [B2205]	CRNT, 1 - 39	The abnormal vehicle speed signal is input from ABS actuator and electric unit (control unit) for 2 seconds or more.	MWI-55
ENGINE SPEED [B2267]	CRNT, 1 - 39	If ECM continuously transmits abnormal engine speed signals for 2 seconds or more.	MWI-56
WATER TEMP [B2268]	CRNT, 1 - 39	If ECM continuously transmits abnormal engine coolant temperature signals for 60 seconds or more.	MWI-57

IPDM E/R (INTELLIGENT POWER DISTRIBUTION MODULE ENGINE ROOM)

< ECU DIAGNOSIS INFORMATION >

IPDM E/R (INTELLIGENT POWER DISTRIBUTION MODULE ENGINE ROOM)

Reference Value

INFOID:000000011008574

VALUES ON THE DIAGNOSIS TOOL

NOTE:

The following table includes information (items) inapplicable to this vehicle. For information (items) applicable to this vehicle, refer to CONSULT display items.

Monitor Item	Condition		Value/Status
RAD FAN REQ	Engine idle speed	Changes depending on engine coolant temperature, air conditioner operation status, vehicle speed, etc.	0 – 100 %
AC COMP REQ	Engine running	A/C switch OFF	Off
		A/C switch ON (Compressor is operating)	On
TAIL&CLR REQ	Lighting switch OFF		Off
	Lighting switch 1ST, 2ND, HI or AUTO (light is illuminated)		On
HL LO REQ	Lighting switch OFF		Off
	Lighting switch 2ND HI or AUTO (light is illuminated)		On
HL HI REQ	Lighting switch OFF		Off
	Lighting switch HI		On
FR FOG REQ	Lighting switch 2ND or AUTO (light is illuminated)	Front fog lamp switch OFF	Off
		<ul style="list-style-type: none"> • Front fog lamp switch ON • Daytime running light activated (Only for Canada) 	On
FR WIP REQ	Ignition switch ON	Front wiper switch OFF	Stop
		Front wiper switch INT	1LOW
		Front wiper switch LO	Low
		Front wiper switch HI	Hi
WIP AUTO STOP	Ignition switch ON	Front wiper stop position	STOP P
		Any position other than front wiper stop position	ACT P
WIP PROT	Ignition switch ON	Front wiper operates normally	Off
		Front wiper stops at fail-safe operation	BLOCK
IGN RLY1 -REQ	Ignition switch OFF or ACC		Off
	Ignition switch ON		On
IGN RLY	Ignition switch OFF or ACC		Off
	Ignition switch ON		On
PUSH SW	Release the push-button ignition switch		Off
	Press the push-button ignition switch		On
INTER/NP SW	Ignition switch ON	Selector lever in any position other than P or N	Off
		Selector lever in P or N position	On
ST RLY CONT	Ignition switch ON		Off
	At engine cranking		On

IPDM E/R (INTELLIGENT POWER DISTRIBUTION MODULE ENGINE ROOM)

< ECU DIAGNOSIS INFORMATION >

Monitor Item	Condition	Value/Status	
IHBT RLY -REQ	Ignition switch ON	Off	A
	At engine cranking	On	
ST/INHI RLY	Ignition switch ON	Off	B
	At engine cranking	INHI → ST	
	The status of starter relay or starter control relay cannot be recognized by the battery voltage malfunction, etc. when the starter relay is ON and the starter control relay is OFF	UNKWN	C
DETENT SW	Ignition switch ON	<ul style="list-style-type: none"> • Press the selector button with selector lever in P position • Selector lever in any position other than P 	D
	Release the selector button with selector lever in P position	On	E
S/L RLY -REQ	NOTE: The item is indicated, but not monitored.	Off	
S/L STATE	NOTE: The item is indicated, but not monitored.	UNLOCK	F
DTRL REQ	NOTE: The item is indicated, but not monitored.	Off	
OIL P SW	Ignition switch OFF, ACC or engine running	Open	G
	Ignition switch ON	Close	
HOOD SW	Close the hood	Off	H
	Open the hood	On	
HL WASHER REQ	NOTE: The item is indicated, but not monitored.	Off	I
THFT HRN REQ	Not operation	Off	
	<ul style="list-style-type: none"> • Panic alarm is activated • Horn is activated with VEHICLE SECURITY (THEFT WARNING) SYSTEM 	On	J
HORN CHIRP	Not operating	Off	
	Door locking with Intelligent Key (horn chirp mode)	On	K
CRNRNG LMP REQ	NOTE: The item is indicated, but not monitored.	Off	L

MWI

IPDM E/R (INTELLIGENT POWER DISTRIBUTION MODULE ENGINE ROOM)

< ECU DIAGNOSIS INFORMATION >

TERMINAL LAYOUT

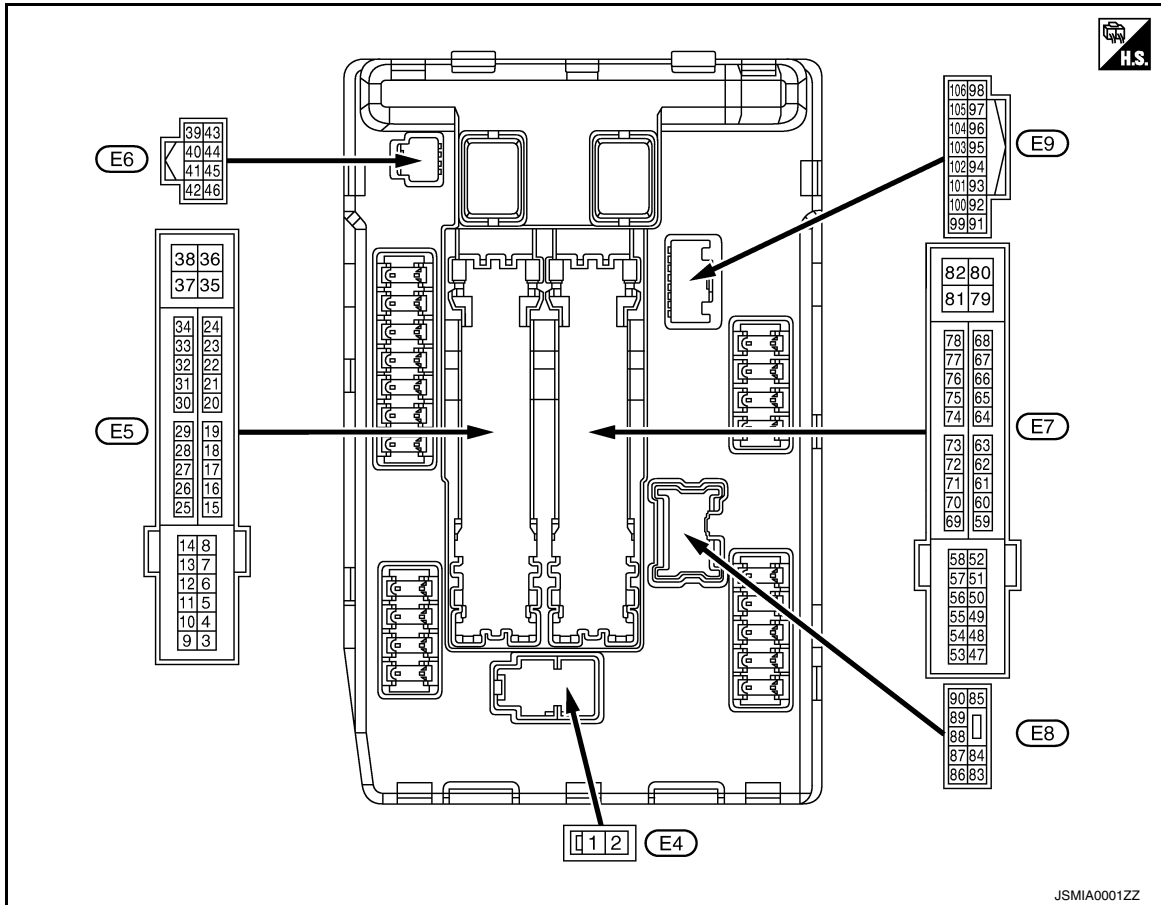

PHYSICAL VALUES

Terminal No. (Wire color)		Description		Condition		Value (Approx.)
+	-	Signal name	Input/ Output			
1 (W)	Ground	Battery power supply	Input	Ignition switch OFF		Battery voltage
2 (L)	Ground	Battery power supply	Input	Ignition switch OFF		Battery voltage
4 (V)	Ground	Front wiper LO	Output	Ignition switch OFF	Front wiper switch OFF	0 V
				Ignition switch ON	Front wiper switch LO	Battery voltage
5 (L)	Ground	Front wiper HI	Output	Ignition switch OFF	Front wiper switch OFF	0 V
				Ignition switch ON	Front wiper switch HI	Battery voltage
7 (R)	Ground	Tail, license plate lamps & interior lamps	Output	Ignition switch OFF	Lighting switch OFF	0 V
				Ignition switch ON	Lighting switch 1ST	Battery voltage
10*1 (SB)	Ground	ECM relay power supply	Output	Ignition switch OFF (More than a few seconds after turning ignition switch OFF)		0 V
				<ul style="list-style-type: none"> Ignition switch ON Ignition switch OFF (For a few seconds after turning igni- tion switch OFF) 		Battery voltage
12 (B)	Ground	Ground	—	Ignition switch ON		0 V

IPDM E/R (INTELLIGENT POWER DISTRIBUTION MODULE ENGINE ROOM)

< ECU DIAGNOSIS INFORMATION >

Terminal No. (Wire color)		Description		Condition	Value (Approx.)
+	-	Signal name	Input/ Output		
13 (Y)	Ground	Fuel pump power supply	Output	Approximately 1 second or more after turning the ignition switch ON	0 V
				<ul style="list-style-type: none"> Approximately 1 second after turning the ignition switch ON Engine running 	Battery voltage
16 (LG)	Ground	Front wiper stop position	Input	Ignition switch ON	0 V
				Front wiper stop position	Battery voltage
19 (W)	Ground	Ignition relay power supply	Output	Ignition switch OFF	0 V
				Ignition switch ON	Battery voltage
25 (G)	Ground	Ignition relay power supply	Output	Ignition switch OFF	0 V
				Ignition switch ON	Battery voltage
26*2 (R)	Ground	Ignition relay power supply	Output	Ignition switch OFF	0 V
				Ignition switch ON	Battery voltage
27 (Y)	Ground	Ignition relay monitor	Input	Ignition switch OFF or ACC	Battery voltage
				Ignition switch ON	0 V
28 (BG)	Ground	Push-button ignition switch	Input	Press the push-button ignition switch	0 V
				Release the push-button ignition switch	Battery voltage
30 (GR)	Ground	Starter relay control	Input	Ignition switch ON	0 V
				Selector lever in any position other than P or N	Battery voltage
36 (G)	Ground	Battery power supply	Input	Ignition switch OFF	Battery voltage
				Ignition switch ON	Battery voltage
39 (P)	—	CAN-L	Input/ Output	—	—
40 (L)	—	CAN-H	Input/ Output	—	—
41 (B)	Ground	Ground	—	Ignition switch ON	0 V
42 (Y)	Ground	Cooling fan relay control	Input	Ignition switch OFF or ACC	0 V
				Ignition switch ON	0.7 V
43 (SB)	Ground	A/T shift selector (Detention switch)	Input	Ignition switch ON	Battery voltage
				<ul style="list-style-type: none"> Press the selector button (Selector lever P) Selector lever in any position other than P 	0 V
44 (W)	Ground	Horn relay control	Input	The horn is deactivated	Battery voltage
				The horn is activated	0 V
45 (G)	Ground	Anti theft horn relay control	Input	The horn is deactivated	Battery voltage
				The horn is activated	0 V
46 (BR)	Ground	Starter relay control	Input	Ignition switch ON	0 V
				Selector lever in any position other than P or N	Battery voltage
48 (L)	Ground	A/C relay power supply	Output	Engine running	0 V
				A/C switch ON (A/C compressor is operating)	Battery voltage

A

B

C

D

E

F

G

H

I

J

K

L

M

MWI

O

P

IPDM E/R (INTELLIGENT POWER DISTRIBUTION MODULE ENGINE ROOM)

< ECU DIAGNOSIS INFORMATION >

Terminal No. (Wire color)		Description		Condition	Value (Approx.)
+	-	Signal name	Input/ Output		
49 (W)*1 (SB)*3	Ground	ECM relay power supply	Output	Ignition switch OFF (More than a few seconds after turning ignition switch OFF)	0 V
				<ul style="list-style-type: none"> • Ignition switch ON • Ignition switch OFF (For a few seconds after turning igni- tion switch OFF) 	Battery voltage
51 (G)	Ground	Ignition relay power supply	Output	Ignition switch OFF	0 V
				Ignition switch ON	Battery voltage
52 (W)	Ground	Ignition relay power supply	Output	Ignition switch OFF	0 V
				Ignition switch ON	Battery voltage
53 (W)	Ground	ECM relay power supply	Output	Ignition switch OFF (More than a few seconds after turning ignition switch OFF)	0 V
				<ul style="list-style-type: none"> • Ignition switch ON • Ignition switch OFF (For a few seconds after turning igni- tion switch OFF) 	Battery voltage
54 (R)	Ground	Throttle control motor re- lay power supply	Output	Ignition switch OFF (More than a few seconds after turning ignition switch OFF)	0 V
				<ul style="list-style-type: none"> • Ignition switch ON • Ignition switch OFF (For a few seconds after turning igni- tion switch OFF) 	Battery voltage
55 (BR)	Ground	ECM power supply	Output	Ignition switch OFF	Battery voltage
56 (BG)*1 (V)*3	Ground	Ignition relay power supply	Output	Ignition switch OFF	0 V
				Ignition switch ON	Battery voltage
57 (LG)	Ground	Ignition relay power supply	Output	Ignition switch OFF	0 V
				Ignition switch ON	Battery voltage
58 (Y)	Ground	Ignition relay power supply	Output	Ignition switch OFF	0 V
				Ignition switch ON	Battery voltage
69 (W)	Ground	ECM relay control	Output	Ignition switch OFF (More than a few seconds after turning ignition switch OFF)	Battery voltage
				<ul style="list-style-type: none"> • Ignition switch ON • Ignition switch OFF (For a few seconds after turning igni- tion switch OFF) 	0 – 1.5 V
70 (BG)	Ground	Throttle control motor re- lay control	Output	Ignition switch ON → OFF	0 – 1.0 V ↓ Battery voltage ↓ 0 V
				Ignition switch ON	0 – 1.0 V
74 (G)	Ground	Ignition relay power supply	Output	Ignition switch OFF	0 V
				Ignition switch ON	Battery voltage
75 (Y)	Ground	Oil pressure switch	Input	Ignition switch ON	0 V
				Engine stopped	Battery voltage
				Engine running	Battery voltage

IPDM E/R (INTELLIGENT POWER DISTRIBUTION MODULE ENGINE ROOM)

< ECU DIAGNOSIS INFORMATION >

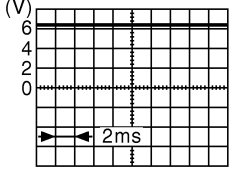
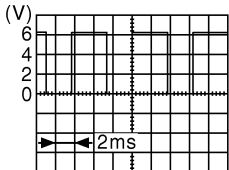
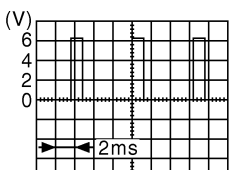
Terminal No. (Wire color)		Description		Condition		Value (Approx.)
+	-	Signal name	Input/ Output			
76 (P) ^{*1} (V) ^{*3}	Ground	Power generation command signal	Output	Ignition switch ON		 <p>6.3 V</p>
				40% is set on "ACTIVE TEST", "ALTERNATOR DUTY" of "ENGINE"		 <p>3.8 V</p>
				80% is set on "ACTIVE TEST", "ALTERNATOR DUTY" of "ENGINE"		 <p>1.4 V</p>
77 (B) ^{*1} (L) ^{*3}	Ground	Fuel pump relay control	Output	<ul style="list-style-type: none"> • Approximately 1 second after turning the ignition switch ON • Engine running 		0 – 1.0 V
				Approximately 1 second or more after turning the ignition switch ON		Battery voltage
80 (W)	Ground	Starter motor	Output	At engine cranking		Battery voltage
83 (R)	Ground	Headlamp LO (RH)	Output	Ignition switch ON	Lighting switch OFF	0 V
					Lighting switch 2ND	Battery voltage
84 (P)	Ground	Headlamp LO (LH)	Output	Ignition switch ON	Lighting switch OFF	0 V
					Lighting switch 2ND	Battery voltage
86 (W)	Ground	Front fog lamp	Output	Lighting switch 2ND	<ul style="list-style-type: none"> • Front fog lamp switch ON • Daytime running light activated (Only for Canada) 	Battery voltage
					Front fog lamp switch OFF	0 V
88 (G)	Ground	Washer pump power supply	Output	Ignition switch ON		Battery voltage
89 (BR)	Ground	Headlamp HI (RH)	Output	Ignition switch ON	<ul style="list-style-type: none"> • Lighting switch HI • Lighting switch PASS 	Battery voltage
					Lighting switch OFF	0 V
90 (Y)	Ground	Headlamp HI (LH)	Output	Ignition switch ON	<ul style="list-style-type: none"> • Lighting switch HI • Lighting switch PASS 	Battery voltage
					Lighting switch OFF	0 V

A

B

C

D

E

F

G

H

I

J

K

L

M

MWI

O

P

IPDM E/R (INTELLIGENT POWER DISTRIBUTION MODULE ENGINE ROOM)

< ECU DIAGNOSIS INFORMATION >

Terminal No. (Wire color)		Description		Condition		Value (Approx.)
+	-	Signal name	Input/ Output			
91 (P)	Ground	Parking lamp	Output	Ignition switch ON	Lighting switch 1ST	Battery voltage
					Lighting switch OFF	0 V
97 (V)	Ground	Cooling fan control	Output	Engine idling		0 – 5 V
104 (LG)	Ground	Hood switch	Input	Close the hood		Battery voltage
				Open the hood		0 V

*1: VK engine models

*2: Only for the models with ICC system

*3: VQ engine models

IPDM E/R (INTELLIGENT POWER DISTRIBUTION MODULE ENGINE ROOM)

< ECU DIAGNOSIS INFORMATION >

Wiring Diagram - IPDM E/R -

INFOID:000000011008575

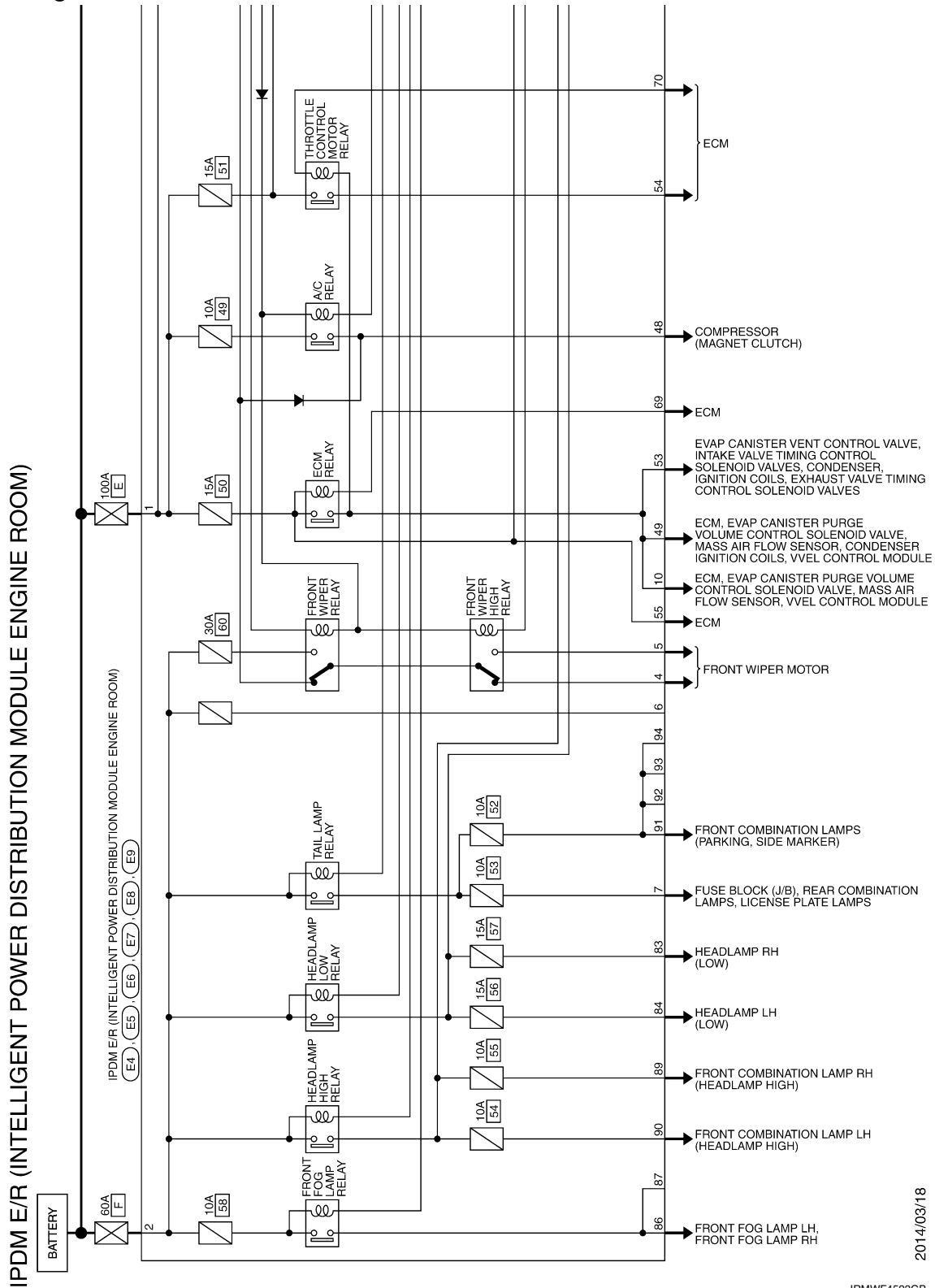

A
B
C
D
E
F
G
H
I
J
K
L
M
N
O
P

MWI

2014/03/18

JRMWF4523GB

IPDM E/R (INTELLIGENT POWER DISTRIBUTION MODULE ENGINE ROOM)

< ECU DIAGNOSIS INFORMATION >

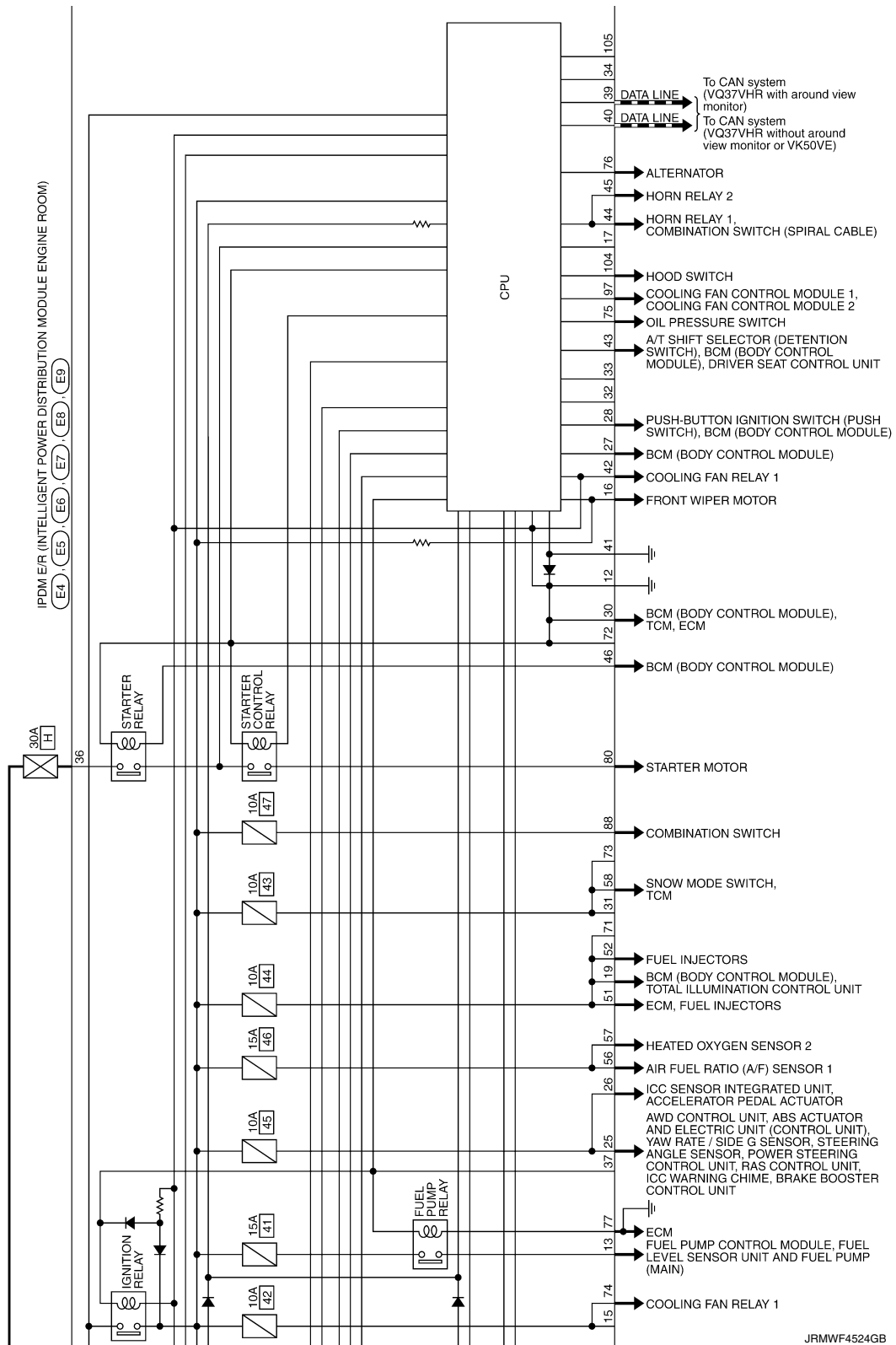

IPDM E/R (INTELLIGENT POWER DISTRIBUTION MODULE ENGINE ROOM)

< ECU DIAGNOSIS INFORMATION >

A
B
C
D
E
F
G
H
I
J
K
L
M
O
P

IPDM E/R
(INTELLIGENT POWER
DISTRIBUTION MODULE
ENGINE ROOM)

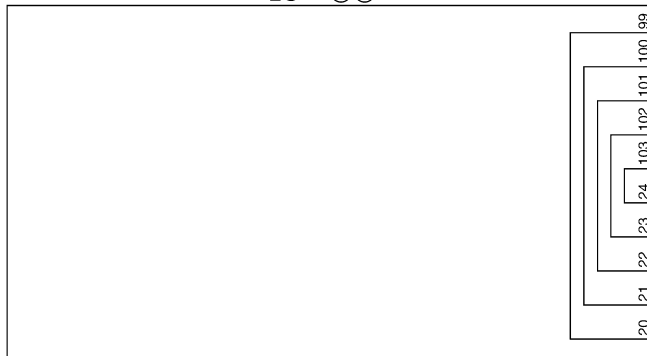

JRMWF4525GB



MWI

IPDM E/R (INTELLIGENT POWER DISTRIBUTION MODULE ENGINE ROOM)



< ECU DIAGNOSIS INFORMATION >

IPDM E/R (INTELLIGENT POWER DISTRIBUTION MODULE ENGINE ROOM)



Terminal No.	Color Of Wire	Signal Name [Specification]
1	W	-
2	L	-

Connector No. E4
IPDM E/R INTELLIGENT POWER DISTRIBUTION MODULE (ENGINE ROOM)
Connector Name L02FB/MC
Connector Type





Terminal No.	Color Of Wire	Signal Name [Specification]
39	P	-
40	L	-
41	B	-
42	Y	-
43	SB	-
44	W	-
45	G	-
46	BR	-

Connector No. E5
IPDM E/R INTELLIGENT POWER DISTRIBUTION MODULE (ENGINE ROOM)
Connector Name T120FM-CS2-M4-1V
Connector Type





Terminal No.	Color Of Wire	Signal Name [Specification]
48	L	-
49	SB	- [With V/G engine]
49	W	- [With VK engine]
51	G	-
52	W	-
53	W	-
54	R	-
55	BR	-
56	BG	- [With VK engine]
56	V	- [With V/G engine]
57	LG	-

Connector No. E7
IPDM E/R INTELLIGENT POWER DISTRIBUTION MODULE (ENGINE ROOM)
Connector Name T120FM-CS2-M4
Connector Type



Terminal No.	Color Of Wire	Signal Name [Specification]
58	Y	-
69	W	-
70	BG	-
74	G	-
75	Y	-
76	P	- [With VK engine]
76	V	- [With V/G engine]
77	B	- [With VK engine]
77	L	- [With V/G engine]
80	W	-

Connector No. E6
IPDM E/R INTELLIGENT POWER DISTRIBUTION MODULE (ENGINE ROOM)
Connector Name T108FM-NH
Connector Type



Terminal No.	Color Of Wire	Signal Name [Specification]
83	R	-
84	P	-
86	W	-
88	G	-
89	BR	-
90	Y	-

Connector No. E9
IPDM E/R INTELLIGENT POWER DISTRIBUTION MODULE (ENGINE ROOM)
Connector Name T118FM-AH
Connector Type

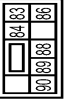

Terminal No.	Color Of Wire	Signal Name [Specification]
97	P	-
104	V	-
104	LG	-

Connector No. E8
IPDM E/R INTELLIGENT POWER DISTRIBUTION MODULE (ENGINE ROOM)
Connector Name NS08FM-CS
Connector Type



JRMWF4526GB

INFOID:000000011008576

Fail-safe

CAN COMMUNICATION CONTROL

When CAN communication with ECM and BCM is impossible, IPDM E/R performs fail-safe control. After CAN communication recovers normally, it also returns to normal control.

If No CAN Communication Is Available With ECM

IPDM E/R (INTELLIGENT POWER DISTRIBUTION MODULE ENGINE ROOM)

< ECU DIAGNOSIS INFORMATION >

Control part	Fail-safe operation
Cooling fan	<ul style="list-style-type: none"> Outputs the pulse duty signal (PWM signal) 100% when the ignition switch is turned ON Outputs the pulse duty signal (PWM signal) 0% when the ignition switch is turned OFF
A/C compressor	A/C relay OFF
Alternator	Outputs the power generation command signal (PWM signal) 0%

If No CAN Communication Is Available With BCM

Control part	Fail-safe operation
Headlamp	<ul style="list-style-type: none"> Turns ON the headlamp low relay when the ignition switch is turned ON Turns OFF the headlamp low relay when the ignition switch is turned OFF Headlamp high relay OFF
<ul style="list-style-type: none"> Parking lamps License plate lamps Side marker lamps Illuminations Tail lamps 	<ul style="list-style-type: none"> Turns ON the tail lamp relay when the ignition switch is turned ON Turns OFF the tail lamp relay when the ignition switch is turned OFF
Front wiper	<ul style="list-style-type: none"> The status just before activation of fail-safe control is maintained until the ignition switch is turned OFF while the front wiper is operating at LO or HI speed. The wiper is operated at LO speed until the ignition switch is turned OFF if the fail-safe control is activated while the front wiper is set in the INT mode and the front wiper motor is operating.
Front fog lamps	Front fog lamp relay OFF
Horn	Horn OFF
Ignition relay	The status just before activation of fail-safe is maintained.
Starter motor	Starter control relay OFF

IGNITION RELAY MALFUNCTION DETECTION FUNCTION

- IPDM E/R monitors the voltage at the contact circuit and excitation coil circuit of the ignition relay inside it.
- IPDM E/R judges the ignition relay error if the voltage differs between the contact circuit and the excitation coil circuit.
- If the ignition relay cannot turn OFF due to contact seizure, it activates the tail lamp relay for 10 minutes to alert the user to the ignition relay malfunction when the ignition switch is turned OFF.

Voltage judgment		IPDM E/R judgment	Operation
Ignition relay contact side	Ignition relay excitation coil side		
ON	ON	Ignition relay ON normal	—
OFF	OFF	Ignition relay OFF normal	—
ON	OFF	Ignition relay ON stuck	<ul style="list-style-type: none"> Detects DTC "B2098: IGN RELAY ON" Turns ON the tail lamp relay for 10 minutes
OFF	ON	Ignition relay OFF stuck	Detects DTC "B2099: IGN RELAY OFF"

FRONT WIPER CONTROL

IPDM E/R detects front wiper stop position by a front wiper stop position signal.

When a front wiper stop position signal is in the conditions listed below, IPDM E/R stops power supply to wiper after repeating a front wiper 10 seconds activation and 20 seconds stop five times.

Ignition switch	Front wiper switch	Front wiper stop position signal
ON	OFF	The front wiper stop position signal (stop position) cannot be input for 10 seconds.
	ON	The front wiper stop position signal does not change for 10 seconds.

IPDM E/R (INTELLIGENT POWER DISTRIBUTION MODULE ENGINE ROOM)

< ECU DIAGNOSIS INFORMATION >

NOTE:

This operation status can be confirmed on the IPDM E/R “Data Monitor” that displays “BLOCK” for the item “WIP PROT” while the wiper is stopped.

STARTER MOTOR PROTECTION FUNCTION

IPDM E/R turns OFF the starter control relay to protect the starter motor when the starter control relay remains active for 90 seconds.

DTC Index

INFOID:000000011008577

NOTE:

- The details of time display are as follows.
 - CRNT: A malfunction is detected now.
 - PAST: A malfunction was detected in the past.
- IGN counter is displayed on FFD (Freeze Frame data).
 - The number is 0 when is detected now.
 - The number increases like 1 → 2 … 38 → 39 after returning to the normal condition whenever IGN OFF → ON.
 - The number is fixed to 39 until the self-diagnosis results are erased if it is over 39.

×: Applicable

CONSULT display	Fail-safe	Reference
No DTC is detected. further testing may be required.	—	—
U1000: CAN COMM CIRCUIT	×	PCS-15
B2098: IGN RELAY ON CIRC	×	PCS-16
B2099: IGN RELAY OFF CIRC	—	PCS-18
B210B: STR CONT RLY ON CIRC	—	SEC-83
B210C: STR CONT RLY OFF CIRC	—	SEC-84
B210D: STARTER RLY ON CIRC	—	SEC-86
B210E: STARTER RLY OFF CIRC	—	SEC-88
B210F: INTRLCK/PNP SW ON	—	SEC-90
B2110: INTRLCK/PNP SW OFF	—	SEC-92

THE FUEL GAUGE POINTER DOES NOT MOVE

< SYMPTOM DIAGNOSIS >

SYMPTOM DIAGNOSIS

THE FUEL GAUGE POINTER DOES NOT MOVE

Description

INFOID:0000000010577093

Fuel gauge needle will not move from a certain position.

Diagnosis Procedure

INFOID:0000000010577094

1. CONDUCTING THE COMBINATION METER SELF-DIAGNOSIS MODE

Perform the self-diagnosis mode of combination meter, and then check that the fuel gauge operates normally. Refer to [MWI-43, "Diagnosis Description"](#).

Is the inspection result normal?

YES >> GO TO 2.

NO >> Replace combination meter. Refer to [MWI-143, "Removal and Installation"](#).

2. CHECK FLOAT INTERFERENCE

Check that the float arm interferes with or binds to other components in the fuel tank.

Is the inspection result normal?

YES >> GO TO 3.

NO >> Repair or replace malfunctioning part.

3. CHECK FUEL LEVEL SENSOR SIGNAL CIRCUIT

Check the fuel level sensor signal circuit. Refer to [MWI-61, "Component Function Check"](#).

Is the inspection result normal?

YES >> Check intermittent incident. Refer to [GI-47, "Intermittent Incident"](#).

NO >> Repair or replace malfunctioning parts.

A
B
C
D
E
F
G
H
I
J
K
L
M
O
P

MWI

THE METER CONTROL SWITCH IS INOPERATIVE

< SYMPTOM DIAGNOSIS >

THE METER CONTROL SWITCH IS INOPERATIVE

Description

INFOID:000000010577095

If any of the following malfunctions is found for the meter control switch operation.

- All switches are inoperative
- The specified switch cannot be operated

Diagnosis Procedure

INFOID:000000010577096

1.CHECK METER CONTROL SWITCH SIGNAL CIRCUIT

Check the meter control switch signal circuit. Refer to [MWI-65, "Diagnosis Procedure"](#).

Is the inspection result normal?

YES >> GO TO 2.

NO >> Repair harness or connector.

2.CHECK METER CONTROL SWITCH UNIT

Perform a unit check for the meter control switch. Refer to [MWI-66, "Component Inspection"](#).

Is the inspection result normal?

YES >> Replace combination meter.

NG >> Replace meter control switch.

THE TRIP A/B RESET SWITCH IS INOPERATIVE

< SYMPTOM DIAGNOSIS >

THE TRIP A/B RESET SWITCH IS INOPERATIVE

Description

INFOID:000000010577097

The trip A/B reset switch is inoperative.

Diagnosis Procedure

INFOID:000000010577098

1.CHECK TRIP A/B RESET SWITCH SIGNAL CIRCUIT

Check the trip A/B reset switch signal circuit. Refer to [MWI-67, "Diagnosis Procedure"](#).

Is the inspection result normal?

YES >> GO TO 2.

NO >> Repair harness or connector.

2.CHECK TRIP A/B RESET SWITCH UNIT

Perform a unit check for the trip A/B reset switch. Refer to [MWI-67, "Component Inspection"](#).

Is the inspection result normal?

YES >> Replace combination meter.

NG >> Replace trip A/B reset switch.

A
B
C
D
E
F
G
H
I
J
K
L
M
O
P

MWI

THE OIL PRESSURE WARNING LAMP DOES NOT TURN ON

< SYMPTOM DIAGNOSIS >

THE OIL PRESSURE WARNING LAMP DOES NOT TURN ON

Description

INFOID:000000010577099

The oil pressure warning lamp stays off when the ignition switch is turned ON

Diagnosis Procedure

INFOID:000000010577100

1. CHECK OIL PRESSURE WARNING LAMP

Perform auto active test. Refer to [PCS-10, "Diagnosis Description"](#).

Does oil pressure warning lamp blink?

YES >> GO TO 2.

NO >> Replace combination meter.

2. CHECK OIL PRESSURE SWITCH SIGNAL CIRCUIT

Check the oil pressure switch signal circuit. Refer to [MWI-69, "Diagnosis Procedure"](#).

Is the inspection result normal?

YES >> GO TO 3.

NO >> Repair harness or connector.

3. CHECK OIL PRESSURE SWITCH UNIT

Perform a unit check for the oil pressure switch. Refer to [MWI-69, "Component Inspection"](#).

Is the inspection result normal?

YES >> Replace IPDM E/R. Refer to [PCS-36, "Removal and Installation"](#).

NO >> Replace oil pressure switch.

THE OIL PRESSURE WARNING LAMP DOES NOT TURN OFF

< SYMPTOM DIAGNOSIS >

THE OIL PRESSURE WARNING LAMP DOES NOT TURN OFF

Description

INFOID:000000010577101

The oil pressure warning lamp remains illuminated while the engine is running (normal oil pressure)

Diagnosis Procedure

INFOID:000000010577102

1. CHECK OIL PRESSURE WARNING LAMP

Perform auto active test. Refer to [PCS-10, "Diagnosis Description"](#).

Does oil pressure warning lamp blink?

- YES >> GO TO 2.
- NO >> Replace combination meter.

2. CHECK IPDM E/R OUTPUT VOLTAGE

1. Disconnect the oil pressure switch connector.
2. Turn ignition switch ON.
3. Check voltage between the oil pressure switch harness connector and ground.

Terminals		Voltage
(+)	(-)	
Oil pressure switch		Approx. 12 V
Connector	Terminal	
F37	1	

Is the inspection result normal?

- YES >> GO TO 3.
- NO >> GO TO 4.

3. CHECK OIL PRESSURE SWITCH UNIT

Perform a unit check for the oil pressure switch. Refer to [MWI-69, "Component Inspection"](#).

Is the inspection result normal?

- YES >> Replace IPDM E/R. Refer to [PCS-36, "Removal and Installation"](#).
- NO >> Replace oil pressure switch.

4. CHECK OIL PRESSURE SWITCH SIGNAL CIRCUIT

Check the oil pressure switch signal circuit. Refer to [MWI-69, "Diagnosis Procedure"](#).

Is the inspection result normal?

- YES >> Replace IPDM E/R. Refer to [PCS-36, "Removal and Installation"](#).
- NO >> Repair harness or connector.

A
B
C
D
E
F
G
H
I
J
K
L
M
O
P

MWI

THE PARKING BRAKE RELEASE WARNING CONTINUES DISPLAYING, OR DOES NOT DISPLAY

< SYMPTOM DIAGNOSIS >

THE PARKING BRAKE RELEASE WARNING CONTINUES DISPLAYING, OR DOES NOT DISPLAY

Description

INFOID:000000010577103

- The parking brake warning is displayed during vehicle travel even though the parking brake is released
- The parking brake warning is not displayed even though driving the vehicle with the parking brake applied

Diagnosis Procedure

INFOID:000000010577104

1. CHECK PARKING BRAKE WARNING LAMP OPERATION

1. Start engine.
2. Check the operation of the parking brake warning lamp when operating the parking brake.

Condition	Warning lamp status
Parking brake applied	ON
Parking brake released	OFF

Is the inspection result normal?

- YES >> Replace combination meter.
NO >> GO TO 2.

2. CHECK PARKING BRAKE SWITCH SIGNAL CIRCUIT

1. Turn ignition switch OFF.
2. Check the parking brake switch signal circuit. Refer to [MWI-70, "Diagnosis Procedure"](#).

Is the inspection result normal?

- YES >> GO TO 3.
NG >> Repair harness or connector.

3. CHECK PARKING BRAKE SWITCH UNIT

Perform a unit check for the parking brake switch. Refer to [BRC-99, "Component Inspection"](#).

Is the inspection result normal?

- YES >> Replace combination meter.
NO >> Replace parking brake switch.

THE LOW WASHER FLUID WARNING CONTINUES DISPLAYING, OR DOES NOT DISPLAY

< SYMPTOM DIAGNOSIS >

THE LOW WASHER FLUID WARNING CONTINUES DISPLAYING, OR DOES NOT DISPLAY

Description

INFOID:000000010577105

- The warning is still displayed even after washer fluid is added
- The warning is not displayed even though the washer tank is empty

Diagnosis Procedure

INFOID:000000010577106

1. CHECK WASHER LEVEL SWITCH SIGNAL CIRCUIT

Check the washer level switch signal circuit. Refer to [MWI-72. "Diagnosis Procedure"](#).

Is the inspection result normal?

YES >> GO TO 2.

NO >> Repair harness or connector.

2. CHECK WASHER LEVEL SWITCH UNIT

Perform a unit check for the washer level switch. Refer to [MWI-72. "Component Inspection"](#).

Is the inspection result normal?

YES >> Replace combination meter.

NO >> Replace washer level switch. Refer to [WW-120. "Removal and Installation"](#).

A
B
C
D
E
F
G
H
I
J
K
L
M
O
P

MWI

THE DOOR OPEN WARNING CONTINUES DISPLAYING, OR DOES NOT DISPLAY

< SYMPTOM DIAGNOSIS >

THE DOOR OPEN WARNING CONTINUES DISPLAYING, OR DOES NOT DISPLAY

Description

INFOID:000000010577107

- The door ajar warning is displayed even though all of the doors are closed.
- The door ajar warning is not displayed even though a door is ajar.

Diagnosis Procedure

INFOID:000000010577108

1. CHECK BCM INPUT/OUTPUT SIGNAL

Connect CONSULT and check the BCM input signals. Refer to [DLK-109, "Component Inspection"](#).

Is the inspection result normal?

- YES >> GO TO 2.
- NO >> GO TO 3.

2. CHECK UNIFIED METER AND A/C AMP. INPUT SIGNAL

Select the "Data Monitor" for the "METER/M&A" and check the "DOOR W/L" monitor value.

"DOOR W/L"

Door open : On
Door closed : Off

Is the inspection result normal?

- YES >> Replace combination meter.
- NO >> Replace BCM. Refer to [BCS-93, "Removal and Installation"](#).

3. CHECK DOOR SWITCH SIGNAL CIRCUIT

Check the door switch signal circuit. Refer to [DLK-107, "Diagnosis Procedure"](#).

Is the inspection result normal?

- YES >> GO TO 4.
- NO >> Repair harness or connector.

4. CHECK DOOR SWITCH UNIT

Perform a unit check for the door switch. Refer to [DLK-109, "Component Inspection"](#).

Is the inspection result normal?

- YES >> Replace combination meter.
- NO >> Replace applicable door switch. Refer to [DLK-356, "Removal and Installation"](#).

THE AMBIENT TEMPERATURE DISPLAY IS INCORRECT

< SYMPTOM DIAGNOSIS >

THE AMBIENT TEMPERATURE DISPLAY IS INCORRECT

Description

INFOID:000000010577109

- The displayed ambient air temperature is higher than the actual temperature.
- The displayed ambient air temperature is lower than the actual temperature.

Diagnosis Procedure

INFOID:000000010577110

NOTE:

Check that the symptom is not applicable to the normal operating condition before starting diagnosis. Refer to [MWI-140, "INFORMATION DISPLAY : Description"](#).

1.CHECK AMBIENT SENSOR SIGNAL CIRCUIT

Check the ambient sensor signal circuit. Refer to [HAC-90, "Diagnosis Procedure"](#).

Is the inspection result normal?

YES >> GO TO 2.

NO >> Repair harness or connector.

2.CHECK AMBIENT SENSOR UNIT

Perform a unit check for the ambient sensor. Refer to [HAC-91, "Component Inspection"](#).

Is the inspection result normal?

YES >> Replace unified meter and A/C amp.

NO >> Replace ambient sensor. Refer to [HAC-195, "Removal and Installation"](#).

A
B
C
D
E
F
G
H
I
J
K
L
M
O
P

MWI

NORMAL OPERATING CONDITION

< SYMPTOM DIAGNOSIS >

NORMAL OPERATING CONDITION COMPASS

COMPASS : Description

INFOID:000000010577111

COMPASS

- The electronic compass is highly protected from changes in most magnetic fields. However, some large changes in magnetic fields can affect it. Some examples are (but not limited to): high tension power lines, large steel buildings, subways, steel bridges, automatic car washes, large piles of scrap metal, etc. While this does not happen very often, it is possible.
- During normal operation, the compass mirror will continuously update the compass calibration to adjust for gradual changes in the vehicle's magnetic "remnant" field. If the vehicle is subjected to high magnetic influences, the compass may appear to indicate false headings, become locked, or appear that it is unable to be calibrated. If this occurs, perform the calibration procedure.
- If at any time the compass continually displays the incorrect direction or the reading is erratic or locked, verify the correct zone variance.

Symptom Chart

Symptom	Cause	Solution / Reference
The compass display reads "C".	<ul style="list-style-type: none">• Compass is not calibrated.• Incorrect zone variance setting.• Large change in magnetic field (Steel bridges, subways, concentrations of metal, carwashes, etc.)• Compass was calibrated incorrectly or in the presence of a strong magnetic field.	Perform calibration. Refer to MWI-39, "Description" .
Compass shows the wrong direction.		
Compass does not change direction appears "Locked".		
Compass does not show all the directions, one or more is missing.		
The compass was calibrated but it "loses" calibration.		
On long trips the compass shows the wrong direction.	Perform zone variation setting if correct reading is desired in that location. Refer to MWI-39, "Description" .	

INFORMATION DISPLAY

INFORMATION DISPLAY : Description

INFOID:000000010577112

AMBIENT AIR TEMPERATURE

The displayed ambient air temperature on the information display may differ from the actual temperature because it is a corrected value calculated from the ambient sensor signal by the unified meter and A/C amp. Refer to [MWI-33, "INFORMATION DISPLAY : System Description"](#) for details on the correction process.

POSSIBLE DRIVING DISTANCE

The calculated possible driving distance may differ from the actual distance to empty if the refueling amount is approximately 15 ℓ (4 US gal, 3-3/10 Imp gal) or less. This is because the refuel control (moves the fuel gauge needle quicker than normal judging that the driver is refueling the vehicle) is not performed in such a case.

PRECAUTIONS

< PRECAUTION >

PRECAUTION

PRECAUTIONS

Precaution for Supplemental Restraint System (SRS) "AIR BAG" and "SEAT BELT PRE-TENSIONER"

INFOID:000000010577113

The Supplemental Restraint System such as "AIR BAG" and "SEAT BELT PRE-TENSIONER", used along with a front seat belt, helps to reduce the risk or severity of injury to the driver and front passenger for certain types of collision. This system includes seat belt switch inputs and dual stage front air bag modules. The SRS system uses the seat belt switches to determine the front air bag deployment, and may only deploy one front air bag, depending on the severity of a collision and whether the front occupants are belted or unbelted. Information necessary to service the system safely is included in the "SRS AIR BAG" and "SEAT BELT" of this Service Manual.

WARNING:

Always observe the following items for preventing accidental activation.

- To avoid rendering the SRS inoperative, which could increase the risk of personal injury or death in the event of a collision that would result in air bag inflation, all maintenance must be performed by an authorized NISSAN/INFINITI dealer.
- Improper maintenance, including incorrect removal and installation of the SRS, can lead to personal injury caused by unintentional activation of the system. For removal of Spiral Cable and Air Bag Module, see "SRS AIR BAG".
- Never use electrical test equipment on any circuit related to the SRS unless instructed to in this Service Manual. SRS wiring harnesses can be identified by yellow and/or orange harnesses or harness connectors.

PRECAUTIONS WHEN USING POWER TOOLS (AIR OR ELECTRIC) AND HAMMERS

WARNING:

Always observe the following items for preventing accidental activation.

- When working near the Air Bag Diagnosis Sensor Unit or other Air Bag System sensors with the ignition ON or engine running, never use air or electric power tools or strike near the sensor(s) with a hammer. Heavy vibration could activate the sensor(s) and deploy the air bag(s), possibly causing serious injury.
- When using air or electric power tools or hammers, always switch the ignition OFF, disconnect the battery, and wait at least 3 minutes before performing any service.

Precautions for Removing Battery Terminal

INFOID:000000011008567

- When removing the 12V battery terminal, turn OFF the ignition switch and wait at least 30 seconds.

NOTE:

ECU may be active for several tens of seconds after the ignition switch is turned OFF. If the battery terminal is removed before ECU stops, then a DTC detection error or ECU data corruption may occur.

- For vehicles with the 2-batteries, be sure to connect the main battery and the sub battery before turning ON the ignition switch.

NOTE:

If the ignition switch is turned ON with any one of the terminals of main battery and sub battery disconnected, then DTC may be detected.

- After installing the 12V battery, always check "Self Diagnosis Result" of all ECUs and erase DTC.

NOTE:

The removal of 12V battery may cause a DTC detection error.

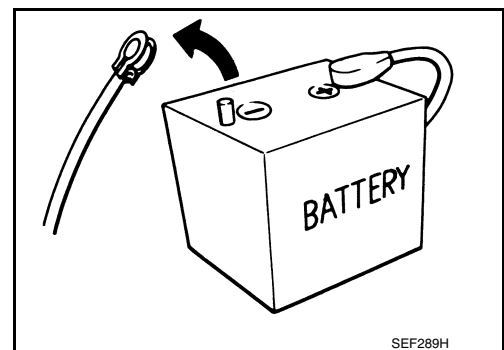

PREPARATION

< PREPARATION >

PREPARATION

PREPARATION

Commercial Service Tools

INFOID:000000010577114

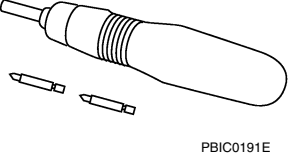
Tool name	Description
<p data-bbox="162 520 267 546">Power tool</p>  <p data-bbox="828 634 901 651">PBIC0191E</p>	<p data-bbox="1006 520 1193 546">Loosening screws</p>

COMBINATION METER

< REMOVAL AND INSTALLATION >

REMOVAL AND INSTALLATION

COMBINATION METER

Exploded View

INFOID:000000010577115

REMOVAL

Refer to [IP-12, "Exploded View"](#).

DISASSEMBLY

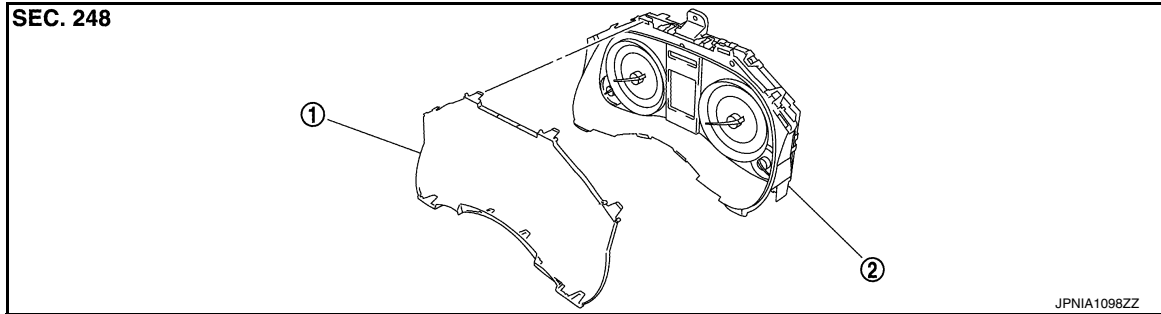

1. Front cover

2. Unified meter control unit

Removal and Installation

INFOID:000000010577116

REMOVAL

1. Remove the cluster lid A. Refer to [IP-23, "Removal and Installation"](#).
2. Remove the combination switch. Refer to [BCS-94, "Removal and Installation"](#).
3. Remove screw (A) and connector, and then remove combination meter (1).

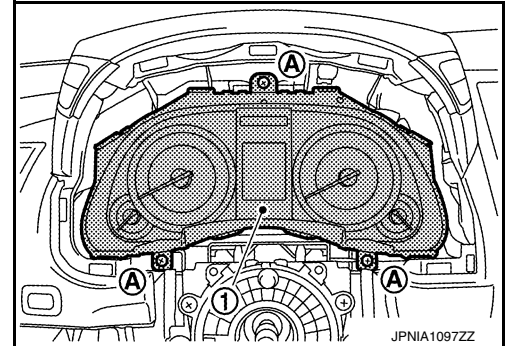

INSTALLATION

Install in the reverse order of removal.

Disassembly and Assembly

INFOID:000000010577117

DISASSEMBLY

Disengage the tabs to separate front cover.

ASSEMBLY

Assemble in the reverse order of disassembly.

A
B
C
D
E
F
G
H
I
J
K
L
M
N
O
P

MWI

UNIFIED METER AND A/C AMP.

< REMOVAL AND INSTALLATION >

UNIFIED METER AND A/C AMP.

Exploded View

INFOID:000000010577118

REMOVAL

Refer to [IP-12. "Exploded View"](#).

DISASSEMBLY

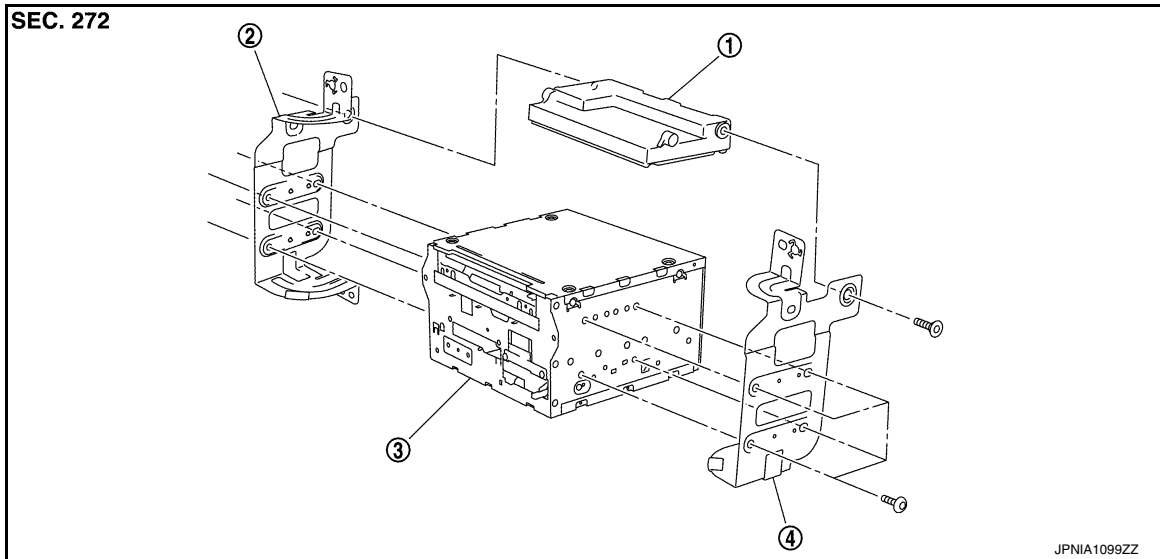

1. Unified meter and A/C amp.
2. Bracket (LH)
3. AV control unit
4. Bracket (RH)

Removal and Installation

INFOID:000000010577119

REMOVAL

1. Remove the display unit. Refer to [AV-132. "Removal and Installation"](#) (without navigation) or [AV-352. "Removal and Installation"](#) (navigation).
2. Remove the unified meter and A/C amp. and AV control unit as an assembly.
3. Remove the bracket screws and remove the unified meter and A/C amp.

INSTALLATION

Install in the reverse order of removal.

NOTE:

- Unified meter and A/C amp. screws are different from other screws. Never confuse them when installing.
- Since AV control unit connector and unified meter and A/C amp. connector have the same form, be careful not insert them wrongly.

METER CONTROL SWITCH

< REMOVAL AND INSTALLATION >

METER CONTROL SWITCH

Exploded View

INFOID:000000010577120

REMOVAL

Refer to [IP-12. "Exploded View"](#).

DISASSEMBLY

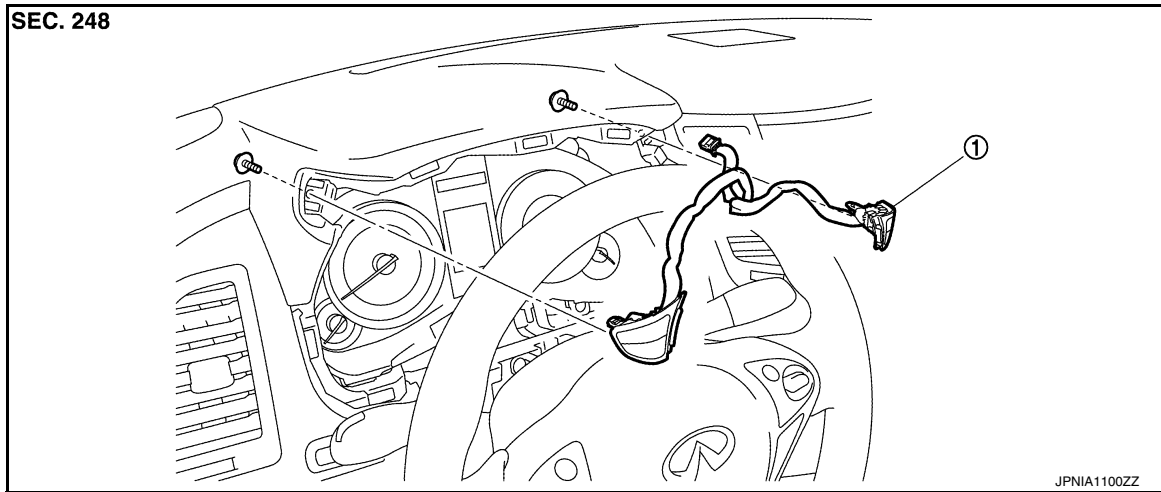

1. Meter control switch

Removal and Installation

INFOID:000000010577121

REMOVAL

1. Remove cluster lid A. Refer to [IP-23. "Removal and Installation"](#).
2. Remove screws and remove meter control switch.
3. Remove meter control switch from instrument panel assembly.

INSTALLATION

Install in the reverse order of removal.

A
B
C
D
E
F
G
H
I
J
K
L
M
N
O
P

MWI

TRIP A/B RESET SWITCH

< REMOVAL AND INSTALLATION >

TRIP A/B RESET SWITCH

Exploded View

INFOID:000000010577122

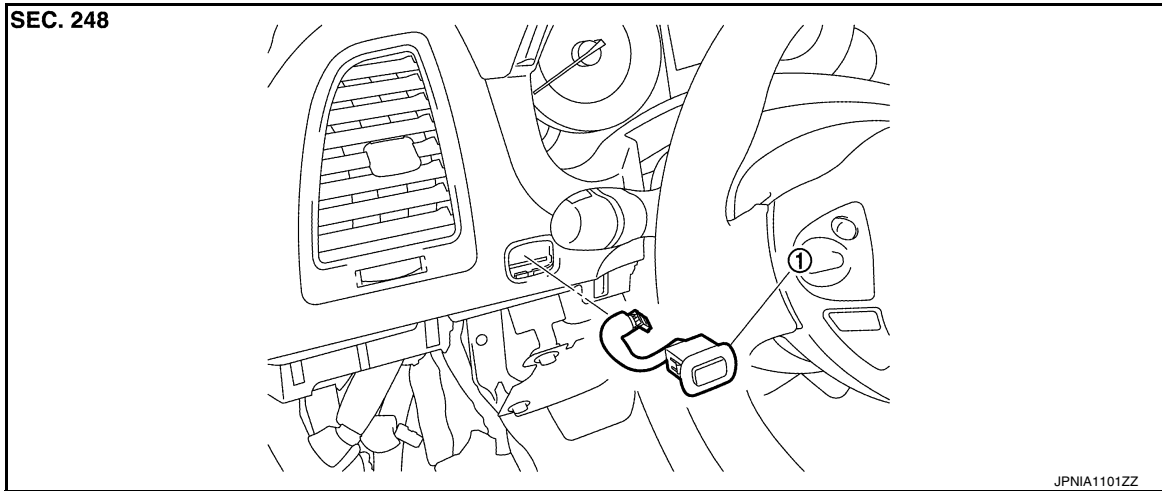

1. Trip A/B reset switch

Removal and Installation

INFOID:000000010577123

REMOVAL

1. Remove instrument lower panel LH. Refer to [IP-23. "Removal and Installation"](#).
2. Press pawls and remove trip A/B reset switch.

INSTALLATION

Install in the reverse order of removal.

COMPASS

< REMOVAL AND INSTALLATION >

COMPASS

Exploded View

INFOID:000000010577124

Refer to [MIR-73. "Exploded View"](#) (WITH ADP) or [MIR-97. "Exploded View"](#) (WITHOUT ADP).

Removal and Installation

INFOID:000000010577125

Refer to [MIR-74. "Removal and Installation"](#) (WITH ADP) or [MIR-98. "Removal and Installation"](#) (WITHOUT ADP).

A
B
C
D
E
F
G
H
I
J
K
L
M
O
P

MWI

CLOCK

< REMOVAL AND INSTALLATION >

CLOCK

Exploded View

INFOID:0000000010577126

REMOVAL

Refer to [IP-12. "Exploded View"](#).

DISASSEMBLY

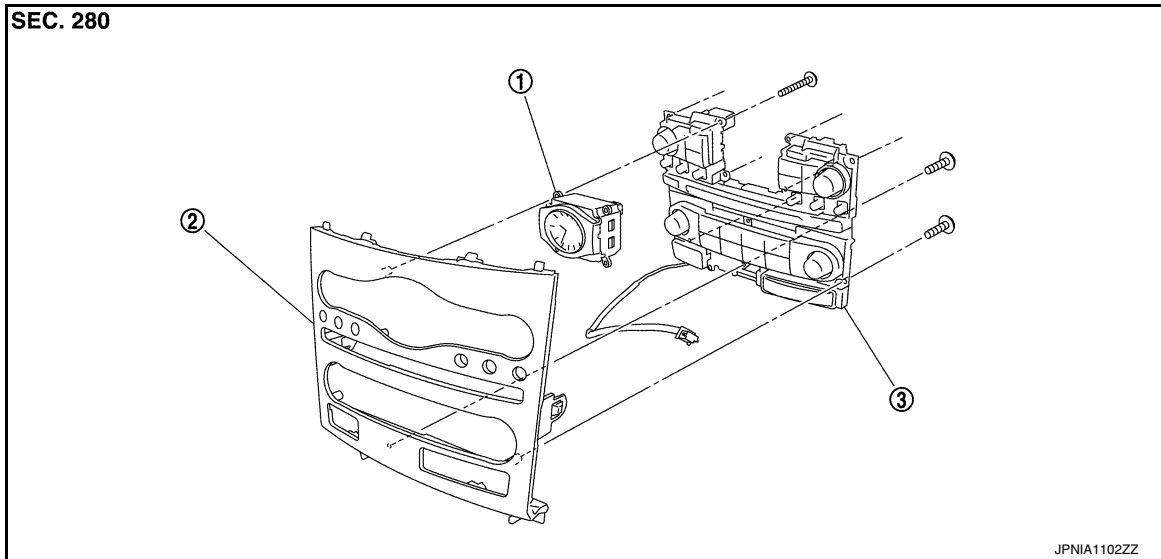

1. Clock

2. Cluster lid C

3. Preset switch

Removal and Installation

INFOID:0000000010577127

REMOVAL

1. Remove cluster lid C assembly. Refer to [IP-23. "Removal and Installation"](#).
2. Remove screws (A), (B), (C) and remove clock (2) in conjunction with preset switch (1) from cluster lid C.
3. Disengage the tabs to separate clock (2).

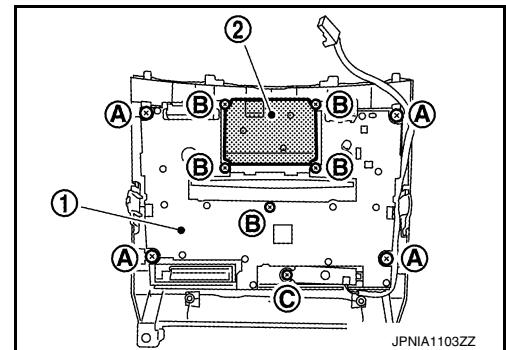

INSTALLATION

Install in the reverse order of removal.

NOTE:

Never confuse screws when installing.