

SECTION **PWC**

POWER WINDOW CONTROL SYSTEM

A
B
C
D
E
F
G
H
I
J
L
M
N
O
P

CONTENTS

<p>PRECAUTION 4</p> <p>PRECAUTIONS 4</p> <p style="padding-left: 20px;">Precaution for Supplemental Restraint System (SRS) "AIR BAG" and "SEAT BELT PRE-TENSIONER"4</p> <p style="padding-left: 20px;">Precaution for Procedure without Cowl Top Cover.....4</p> <p style="padding-left: 20px;">Precautions for Removing of Battery Terminal4</p> <p>PREPARATION 6</p> <p>PREPARATION 6</p> <p style="padding-left: 20px;">Commercial Service Tools6</p> <p>SYSTEM DESCRIPTION 7</p> <p>COMPONENT PARTS 7</p> <p style="padding-left: 20px;">Component Parts Location7</p> <p style="padding-left: 20px;">Component Description8</p> <p>SYSTEM 9</p> <p style="padding-left: 20px;">System Diagram9</p> <p style="padding-left: 20px;">System Description9</p> <p style="padding-left: 20px;">Fail-safe 11</p> <p>DIAGNOSIS SYSTEM (BCM)12</p> <p>COMMON ITEM 12</p> <p style="padding-left: 20px;">COMMON ITEM : CONSULT Function (BCM - COMMON ITEM) 12</p> <p>RETAIND PWR 13</p> <p style="padding-left: 20px;">RETAIND PWR : CONSULT Function (BCM - RETAINED PWR) 13</p> <p>ECU DIAGNOSIS INFORMATION14</p> <p>BCM (BODY CONTROL MODULE)14</p> <p style="padding-left: 20px;">List of ECU Reference 14</p> <p>POWER WINDOW MAIN SWITCH15</p> <p style="padding-left: 20px;">Reference Value 15</p> <p style="padding-left: 20px;">Fail-safe 16</p>	<p>FRONT POWER WINDOW SWITCH (PASSENGER SIDE)17</p> <p style="padding-left: 20px;">Reference Value17</p> <p style="padding-left: 20px;">Fail-safe18</p> <p>REAR POWER WINDOW SWITCH LH19</p> <p style="padding-left: 20px;">Reference Value19</p> <p style="padding-left: 20px;">Fail-safe20</p> <p>REAR POWER WINDOW SWITCH RH21</p> <p style="padding-left: 20px;">Reference Value21</p> <p style="padding-left: 20px;">Fail-safe22</p> <p>WIRING DIAGRAM23</p> <p>POWER WINDOW SYSTEM23</p> <p style="padding-left: 20px;">Wiring Diagram23</p> <p>BASIC INSPECTION31</p> <p>DIAGNOSIS AND REPAIR WORKFLOW31</p> <p style="padding-left: 20px;">Work Flow31</p> <p>ADDITIONAL SERVICE WHEN REMOVING BATTERY NEGATIVE TERMINAL32</p> <p style="padding-left: 20px;">Description32</p> <p style="padding-left: 20px;">Work Procedure32</p> <p>ADDITIONAL SERVICE WHEN REPLACING CONTROL UNIT33</p> <p style="padding-left: 20px;">Description33</p> <p style="padding-left: 20px;">Work Procedure33</p> <p>SYSTEM INITIALIZATION34</p> <p style="padding-left: 20px;">Description34</p> <p style="padding-left: 20px;">Work Procedure34</p> <p>CHECK ANTI-PINCH FUNCTION35</p> <p style="padding-left: 20px;">Description35</p> <p style="padding-left: 20px;">Work Procedure35</p> <p>DTC/CIRCUIT DIAGNOSIS36</p>
----------------------------------------------------------------------------------------------------------------------------------------------------------------------------------------------------------------------------------------------------------------------------------------------------------------------------------------------------------------------------------------------------------------------------------------------------------------------------------------------------------------------------------------------------------------------------------------------------------------------------------------------------------------------------------------------------------------------------------------------------------------------------------------------------------------------------------------------------------------------------------------------------------------------------------------------------------------------------------------------------------------------------------------------------------------------------------------------------------------------------------------------------------------------------------------------------------------------------------------------------------------------------------------------------------------------------------------------------------------------------------------------------------------------------------------------------------------------------------------------------------------------------------------------------------------------------------------------------------------	---------------------------------------------------------------------------------------------------------------------------------------------------------------------------------------------------------------------------------------------------------------------------------------------------------------------------------------------------------------------------------------------------------------------------------------------------------------------------------------------------------------------------------------------------------------------------------------------------------------------------------------------------------------------------------------------------------------------------------------------------------------------------------------------------------------------------------------------------------------------------------------------------------------------------------------------------------------------------------------------------------------------------------------------------------------------------------------------------------------------------------------------------------------------------------------------------------------------------------------------------------------------------------------------------------------------------------------------------------------------------------------------------------------------------------------------------------------------------------------------------------------------------------------------------------------------------------

PWC

POWER SUPPLY AND GROUND CIRCUIT	36	POWER WINDOW MAIN SWITCH : Diagnosis Procedure	56
POWER WINDOW MAIN SWITCH	36	FRONT POWER WINDOW SWITCH (PASSENGER SIDE)	57
POWER WINDOW MAIN SWITCH : Diagnosis Procedure	36	FRONT POWER WINDOW SWITCH (PASSENGER SIDE) : Component Function Check	57
FRONT POWER WINDOW SWITCH (PASSENGER SIDE)	37	FRONT POWER WINDOW SWITCH (PASSENGER SIDE) : Diagnosis Procedure	57
FRONT POWER WINDOW SWITCH (PASSENGER SIDE) : Diagnosis Procedure	37	REAR POWER WINDOW SWITCH LH	58
REAR POWER WINDOW SWITCH	38	REAR POWER WINDOW SWITCH LH : Component Function Check	59
REAR POWER WINDOW SWITCH : Diagnosis Procedure	38	REAR POWER WINDOW SWITCH LH : Diagnosis Procedure	59
POWER WINDOW MOTOR	40	REAR POWER WINDOW SWITCH RH	60
DRIVER SIDE	40	REAR POWER WINDOW SWITCH RH : Component Function Check	60
DRIVER SIDE : Component Function Check	40	REAR POWER WINDOW SWITCH RH : Diagnosis Procedure	60
DRIVER SIDE : Diagnosis Procedure	40	SYMPTOM DIAGNOSIS	62
PASSENGER SIDE	40	POWER WINDOWS DO NOT OPERATE WITH POWER WINDOW MAIN SWITCH	62
PASSENGER SIDE : Component Function Check	41	Diagnosis Procedure	62
PASSENGER SIDE : Diagnosis Procedure	41	DRIVER SIDE POWER WINDOW ALONE DOES NOT OPERATE	63
REAR LH	41	Diagnosis Procedure	63
REAR LH : Component Function Check	42	FRONT PASSENGER SIDE POWER WINDOW DOES NOT OPERATE	64
REAR LH : Diagnosis Procedure	42	WHEN POWER WINDOW MAIN SWITCH IS OPERATED	64
REAR RH	42	WHEN POWER WINDOW MAIN SWITCH IS OPERATED : Diagnosis Procedure	64
REAR RH : Component Function Check	42	WHEN FRONT POWER WINDOW SWITCH (PASSENGER SIDE) IS OPERATED	64
REAR RH : Diagnosis Procedure	43	WHEN FRONT POWER WINDOW SWITCH (PASSENGER SIDE) IS OPERATED : Diagnosis Procedure	64
ENCODER	44	WHEN BOTH POWER WINDOW MAIN SWITCH AND FRONT POWER WINDOW SWITCH ARE OPERATED	64
DRIVER SIDE	44	WHEN BOTH POWER WINDOW MAIN SWITCH AND FRONT POWER WINDOW SWITCH ARE OPERATED : Diagnosis Procedure	64
DRIVER SIDE : Component Function Check	44	REAR LH SIDE POWER WINDOW ALONE DOES NOT OPERATE	65
DRIVER SIDE : Diagnosis Procedure	44	WHEN POWER WINDOW MAIN SWITCH IS OPERATED	65
PASSENGER SIDE	46	WHEN POWER WINDOW MAIN SWITCH IS OPERATED : Diagnosis Procedure	65
PASSENGER SIDE : Component Function Check	46		
PASSENGER SIDE : Diagnosis Procedure	46		
REAR LH	48		
REAR LH : Component Function Check	49		
REAR LH : Diagnosis Procedure	49		
REAR RH	51		
REAR RH : Component Function Check	51		
REAR RH : Diagnosis Procedure	51		
DOOR KEY CYLINDER SWITCH	54		
Component Function Check	54		
Diagnosis Procedure	54		
Component Inspection	55		
POWER WINDOW SERIAL LINK	56		
POWER WINDOW MAIN SWITCH	56		
POWER WINDOW MAIN SWITCH : Component Function Check	56		

WHEN REAR POWER WINDOW SWITCH LH IS OPERATED	65	ANTI-PINCH FUNCTION DOES NOT OPERATE	69	A
WHEN REAR POWER WINDOW SWITCH LH IS OPERATED : Diagnosis Procedure	65	Diagnosis Procedure	69	
WHEN BOTH POWER WINDOW MAIN SWITCH AND REAR POWER WINDOW SWITCH LH ARE OPERATED	65	POWER WINDOW RETAINED POWER FUNCTION DOES NOT OPERATE NORMALLY	70	B
WHEN BOTH POWER WINDOW MAIN SWITCH AND REAR POWER WINDOW SWITCH LH ARE OPERATED : Diagnosis Procedure	65	Diagnosis Procedure	70	C
REAR RH SIDE POWER WINDOW ALONE DOES NOT OPERATE	66	DOOR KEY CYLINDER SWITCH DOES NOT OPERATE POWER WINDOWS	71	D
WHEN POWER WINDOW MAIN SWITCH IS OPERATED	66	Diagnosis Procedure	71	
WHEN POWER WINDOW MAIN SWITCH IS OPERATED : Diagnosis Procedure	66	KEYLESS POWER WINDOW DOWN DOES NOT OPERATE	72	E
WHEN REAR POWER WINDOW SWITCH RH IS OPERATED	66	Diagnosis Procedure	72	
WHEN REAR POWER WINDOW SWITCH RH IS OPERATED : Diagnosis Procedure	66	POWER WINDOW LOCK SWITCH DOES NOT FUNCTION	73	F
WHEN BOTH POWER WINDOW MAIN SWITCH AND REAR POWER WINDOW SWITCH RH ARE OPERATED	66	Diagnosis Procedure	73	
WHEN BOTH POWER WINDOW MAIN SWITCH AND REAR POWER WINDOW SWITCH RH ARE OPERATED : Diagnosis Procedure	66	POWER WINDOW SWITCH DOES NOT ILLUMINATE	74	G
AUTO OPERATION DOES NOT OPERATE BUT MANUAL OPERATE NORMALLY	67	DRIVER SIDE	74	H
DRIVER SIDE	67	DRIVER SIDE : Diagnosis Procedure	74	
DRIVER SIDE : Diagnosis Procedure	67	PASSENGER SIDE	74	I
PASSENGER SIDE	67	PASSENGER SIDE : Diagnosis Procedure	74	
PASSENGER SIDE : Diagnosis Procedure	67	REAR LH	74	J
REAR LH	67	REAR LH : Diagnosis Procedure	74	
REAR LH : Diagnosis Procedure	67	REAR RH	74	
REAR RH	68	REAR RH : Diagnosis Procedure	74	
REAR RH : Diagnosis Procedure	68	REMOVAL AND INSTALLATION	75	PWC
ANTI-PINCH FUNCTION DOES NOT OPERATE	69	POWER WINDOW MAIN SWITCH	75	L
Diagnosis Procedure	69	Removal and Installation	75	
POWER WINDOW RETAINED POWER FUNCTION DOES NOT OPERATE NORMALLY	70	FRONT POWER WINDOW SWITCH (PASSENGER SIDE)	76	M
Diagnosis Procedure	70	Removal and Installation	76	
DOOR KEY CYLINDER SWITCH DOES NOT OPERATE POWER WINDOWS	71	REAR POWER WINDOW SWITCH	77	N
Diagnosis Procedure	71	Removal and Installation	77	O
KEYLESS POWER WINDOW DOWN DOES NOT OPERATE	72			P
Diagnosis Procedure	72			
POWER WINDOW LOCK SWITCH DOES NOT FUNCTION	73			
Diagnosis Procedure	73			
POWER WINDOW SWITCH DOES NOT ILLUMINATE	74			
DRIVER SIDE	74			
DRIVER SIDE : Diagnosis Procedure	74			
PASSENGER SIDE	74			
PASSENGER SIDE : Diagnosis Procedure	74			
REAR LH	74			
REAR LH : Diagnosis Procedure	74			
REAR RH	74			
REAR RH : Diagnosis Procedure	74			
REMOVAL AND INSTALLATION	75			
POWER WINDOW MAIN SWITCH	75			
Removal and Installation	75			
FRONT POWER WINDOW SWITCH (PASSENGER SIDE)	76			
Removal and Installation	76			
REAR POWER WINDOW SWITCH	77			
Removal and Installation	77			

PRECAUTIONS

< PRECAUTION >

PRECAUTION

PRECAUTIONS

Precaution for Supplemental Restraint System (SRS) "AIR BAG" and "SEAT BELT PRE-TENSIONER"

INFOID:000000009009716

The Supplemental Restraint System such as "AIR BAG" and "SEAT BELT PRE-TENSIONER", used along with a front seat belt, helps to reduce the risk or severity of injury to the driver and front passenger for certain types of collision. Information necessary to service the system safely is included in the "SRS AIR BAG" and "SEAT BELT" of this Service Manual.

WARNING:

Always observe the following items for preventing accidental activation.

- To avoid rendering the SRS inoperative, which could increase the risk of personal injury or death in the event of a collision that would result in air bag inflation, all maintenance must be performed by an authorized NISSAN/INFINITI dealer.
- Improper maintenance, including incorrect removal and installation of the SRS, can lead to personal injury caused by unintentional activation of the system. For removal of Spiral Cable and Air Bag Module, see "SRS AIR BAG".
- Never use electrical test equipment on any circuit related to the SRS unless instructed to in this Service Manual. SRS wiring harnesses can be identified by yellow and/or orange harnesses or harness connectors.

PRECAUTIONS WHEN USING POWER TOOLS (AIR OR ELECTRIC) AND HAMMERS

WARNING:

Always observe the following items for preventing accidental activation.

- When working near the Air Bag Diagnosis Sensor Unit or other Air Bag System sensors with the ignition ON or engine running, never use air or electric power tools or strike near the sensor(s) with a hammer. Heavy vibration could activate the sensor(s) and deploy the air bag(s), possibly causing serious injury.
- When using air or electric power tools or hammers, always switch the ignition OFF, disconnect the battery, and wait at least 3 minutes before performing any service.

Precaution for Procedure without Cowl Top Cover

INFOID:000000009009717

When performing the procedure after removing cowl top cover, cover the lower end of windshield with urethane, etc to prevent damage to windshield.

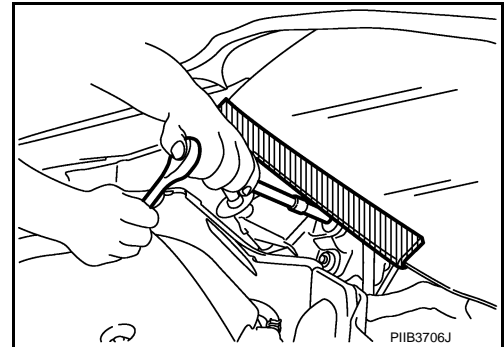

Precautions for Removing of Battery Terminal

INFOID:000000009898145

- When removing the 12V battery terminal, turn OFF the ignition switch and wait at least 30 seconds.

NOTE:

ECU may be active for several tens of seconds after the ignition switch is turned OFF. If the battery terminal is removed before ECU stops, then a DTC detection error or ECU data corruption may occur.

- For vehicles with the 2-batteries, be sure to connect the main battery and the sub battery before turning ON the ignition switch.

NOTE:

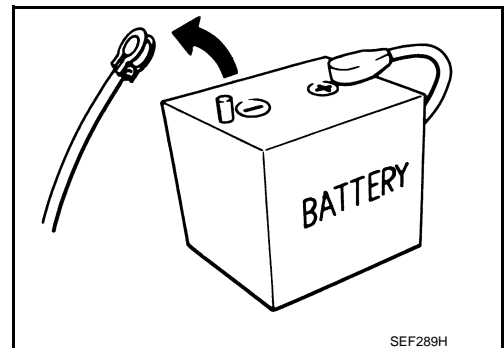

PRECAUTIONS

< PRECAUTION >

If the ignition switch is turned ON with any one of the terminals of main battery and sub battery disconnected, then DTC may be detected.

- After installing the 12V battery, always check "Self Diagnosis Result" of all ECUs and erase DTC.

NOTE:

The removal of 12V battery may cause a DTC detection error.

A

B

C

D

E

F

G

H

I

J

PWC

L

M

N

O

P

PREPARATION

< PREPARATION >

PREPARATION

PREPARATION

Commercial Service Tools

INFOID:000000009009718

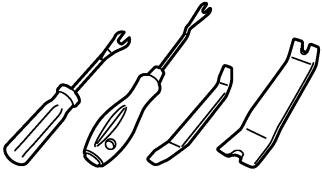
Tool name	Description
Remover tool  JMKIA3050ZZ	Removes the clips, pawls and metal clips

COMPONENT PARTS

< SYSTEM DESCRIPTION >

SYSTEM DESCRIPTION

COMPONENT PARTS

Component Parts Location

INFOID:000000009009719

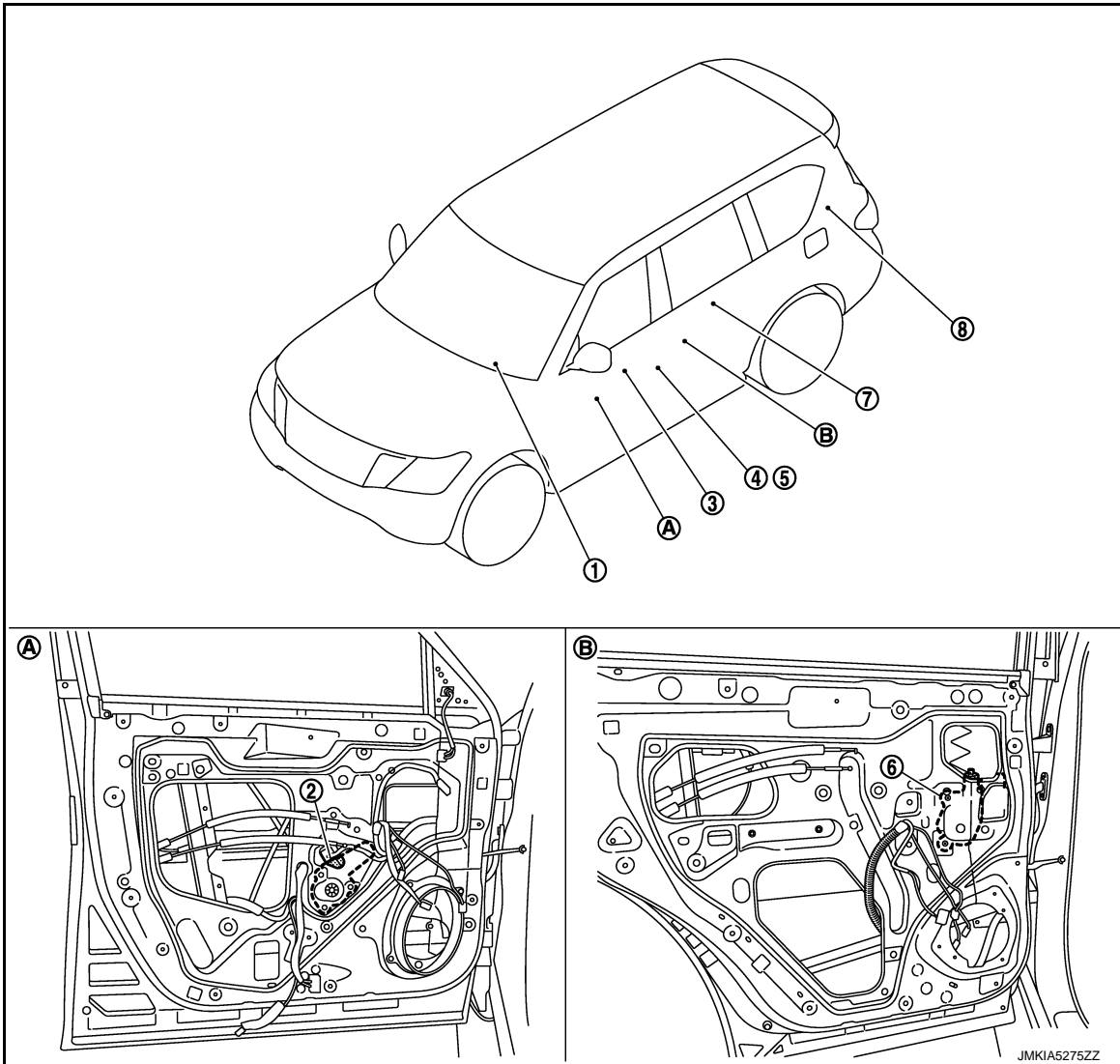

1. BCM
Refer to [BCS-4, "BODY CONTROL SYSTEM : Component Parts Location"](#)
 2. Front power window motor (driver side)
 3. Power window main switch
 4. Front door lock assembly (driver side) (door key cylinder switch)
 5. Front door switch (driver side)
 6. Rear power window motor LH
 7. Rear power window switch LH
 8. Remote keyless entry receiver
Refer to [DLK-11, "DOOR LOCK SYSTEM : Component Parts Location"](#)
- A. View with front door finisher removed B. View with rear door finisher removed

A
B
C
D
E
F
G
H
I
J
L
M
N
O
P

PWC

COMPONENT PARTS

< SYSTEM DESCRIPTION >

Component Description

INFOID:000000009009720

Component	Function
BCM	<ul style="list-style-type: none">• Supplies power supply to power window switch.• Controls retained power.
Power window main switch	<ul style="list-style-type: none">• Directly controls all power window motor of all doors.• Controls anti-pinch operation of power window.
Front power window switch (passenger side)	<ul style="list-style-type: none">• Controls anti-pinch operation of power window.• Controls power window motor of passenger door.
Rear power window switch	<ul style="list-style-type: none">• Controls anti-pinch operation of power window.• Controls power window motor of rear right and left doors.
Power window motor	<ul style="list-style-type: none">• Integrates the encoder and window motor.• Starts operating with signals from each power window switch.• Transmits power window motor rotation as a pulse signal to power window switch.
Remote keyless entry receiver	Receives lock/unlock signal from the intelligent key, and then transmits to BCM.
Front door lock assembly (door key cylinder switch)	Transmits operation condition of door key cylinder switch to power window main switch.
Front door switch (driver side/passenger side)	Front door open/close condition and transmits to BCM.

SYSTEM

< SYSTEM DESCRIPTION >

SYSTEM

System Diagram

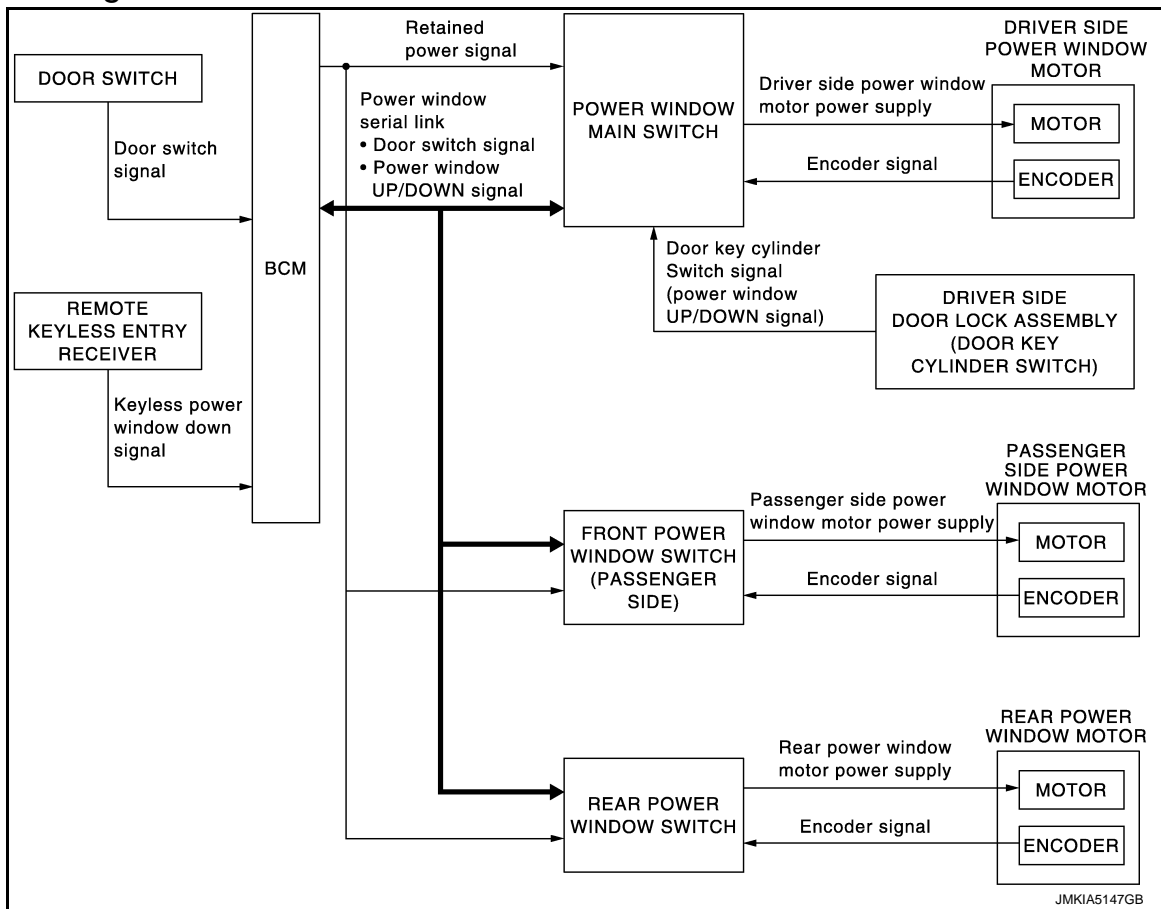

System Description

INFOID:000000009009722

POWER WINDOW OPERATION

- Power window system is activated by power window switch operation when ignition switch turns ON, or during the retained power operation after ignition switch turns OFF.
- Power window main switch can open/close door glass.
- Front and rear power window switch can open/close the corresponding door glass.
- Power window lock switch can lock all power windows other than driver seat.
- All power windows close when pressing Intelligent Key lock button for 3 seconds.
- If door glass receives resistance that is the specified value or more while power window of each seat is in AUTO-UP operation, power window operates in the reverse direction.
- Power window serial link transmits the signals from power window main switch to each power window switch.
- AUTO-UP/DOWN operation can be performed when front power window switch turns to AUTO.

POWER WINDOW AUTO-OPERATION

- AUTO-UP/DOWN operation can be performed when each power window motor turns to AUTO.
- Encoder continues detecting the movement of power window motor and output the encoder pulse signal to power window switch while power window motor is operating.
- Power window switch reads the changes of encoder signal and stops AUTO operation when door glass is at fully opened/closed position.
- Power window motor is operable in case encoder is malfunctioning.
- AUTO function does not operate if encoder is malfunctioning.

POWER WINDOW SERIAL LINK

Power window main switch, front power window switch (passenger side), rear power window switch LH/RH and BCM transmit and receive the signal by power window serial link.

A
B
C
D
E
F
G
H
I
J

PWC

L
M
N
O
P

SYSTEM

< SYSTEM DESCRIPTION >

The signal mentioned below is transmitted from BCM to power window main switch, front power window switch (passenger side) and rear power window switch LH/RH.

- Keyless power window down signal
- Door switch signal

The signal mentioned below is transmitted from power window main switch to front power window switch (passenger side) and rear power window switch LH/RH.

- Front passenger side door window and rear door window operation signal
- Power window control by door key cylinder switch signal
- Power window lock switch signal
- Retained power operation signal

RETAINED POWER OPERATION

- Retained power operation is an additional power supply function that enables power window system to operate during the 45 seconds even when ignition switch is turned OFF.

Retained Power Function Cancel Conditions

- Front door CLOSE (door switch OFF)→OPEN (door switch ON).
- When ignition switch is ON again.
- When timer time passes. (45 seconds)

POWER WINDOW LOCK FUNCTION

Ground circuit inside power window main switch shuts off when power window lock switch is ON. This inhibits power window switch operation except with the power window main switch.

ANTI-PINCH OPERATION

- Anti-pinch foreign lowers door glass 150 mm (5.9 in) when foreign material is pinched in door glass during AUTO-UP operation.
- Encoder continues detecting the movement of power window motor and output the encoder pulse signal to power window switch while power window motor is operating.
- Resistance is applied to the power window motor rotation that changes the frequency of encoder pulse signal if foreign material is trapped in the door glass.
- Power window switch controls to lower the door glass for 150 mm (5.9 in) after it detects encoder pulse signal frequency change.

Operation Condition

When all door glass AUTO-UP operation is performed (anti-pinch function does not operate just before the door glass closes and is fully closed)

NOTE:

Depending on environment and driving conditions, if a similar impact or load is applied to the door glass, it may lower.

DOOR KEY CYLINDER SWITCH OPERATION

Hold the door key cylinder to the LOCK or UNLOCK direction for 1.5 seconds or more to OPEN or CLOSE all power windows when ignition switch is OFF. In addition, it stops when key position is moved to NEUTRAL when operating.

Operation Condition

- Ignition switch OFF.
- Hold door key cylinder to LOCK position for 1.5 seconds or more to perform CLOSE operation of the door glass.
- Hold door key cylinder to UNLOCK position for 1.5 seconds or more to perform OPEN operation of the door glass.

KEYLESS POWER WINDOW DOWN FUNCTION

All power windows open when the unlock button on Intelligent Key is activated and kept pressed for more than 3 seconds with the ignition switch OFF. The windows keep opening if the unlock button is continuously pressed.

The power window opening stops when the following operations are performed.

- When the unlock button is kept pressed more than 15 seconds.
- When the ignition switch is turned ON while the power window opening is operated.
- When the unlock button is released.

While retained power operation activate, keyless power window down function cannot be operated.

SYSTEM

< SYSTEM DESCRIPTION >

Keyless power window down operation function can be changed by "PW DOWN SET" in "WORK SUPPORT" mode of "INTELLIGENT KEY" of "BCM" using CONSULT. Refer to [DLK-42, "INTELLIGENT KEY : CONSULT Function \(BCM - INTELLIGENT KEY\)"](#).

Fail-safe

INFOID:000000009009723

FAIL-SAFE CONTROL

Switches to fail-safe control when malfunction is detected in encoder signal that detects up/down speed and direction of door glass. Switches to fail-safe control when a signal that is out of the specified value is detected between the fully closed position and the actual position of the glass.

Malfunction	Malfunction condition
Pulse sensor malfunction	When one pulse signal that is the specified value or more is detected continuously for the specified time or more, while door glass is being operated UP or DOWN.
Both pulse sensors malfunction	When both pulse signals are not detected continuously for the specified time or more, while door glass is being operated UP or DOWN.
Pulse direction malfunction	When a pulse signal indicating that window is moving in the opposite direction against the power window motor is detected for the specified value or more, while door glass is being operated UP or DOWN.
Glass recognition position malfunction 1	When the actual door glass position that is out of specified value is detected compared to the door glass fully closed position memorized in module, while door glass is being operated UP or DOWN.
Glass recognition position malfunction 2	When pulse count that is out of the door glass full stroke value or more is detected, while door glass is being operated UP or DOWN.

If fail-safe control, the system changes to a non-initialized condition and the following function do not operate.

- Auto-up operation
- Anti-pinch function
- Retained power function

When fail-safe control is activated, perform the initialization procedure to recover. However, if a malfunction is still detected in power window switch, the fail-safe control is activated again.

PWC

DIAGNOSIS SYSTEM (BCM)

< SYSTEM DESCRIPTION >

DIAGNOSIS SYSTEM (BCM)

COMMON ITEM

COMMON ITEM : CONSULT Function (BCM - COMMON ITEM)

INFOID:000000009355169

APPLICATION ITEM

CONSULT performs the following functions via CAN communication with BCM.

Diagnosis mode	Function Description
Work Support	Changes the setting for each system function.
Self Diagnostic Result	Displays the diagnosis results judged by BCM. Refer to BCS-57, "DTC Index" .
CAN Diag Support Monitor	Monitors the reception status of CAN communication viewed from BCM.
Data Monitor	The BCM input/output signals are displayed.
Active Test	The signals used to activate each device are forcibly supplied from BCM.
Ecu Identification	The BCM part number is displayed.
Configuration	<ul style="list-style-type: none"> Read and save the vehicle specification. Write the vehicle specification when replacing BCM.

SYSTEM APPLICATION

BCM can perform the following functions for each system.

NOTE:

It can perform the diagnosis modes except the following for all sub system selection items.

×: Applicable item

System	Sub system selection item	Diagnosis mode		
		Work Support	Data Monitor	Active Test
Door lock	DOOR LOCK	×	×	×
Rear window defogger	REAR DEFOGGER		×	×
Warning chime	BUZZER		×	×
Interior room lamp timer	INT LAMP	×	×	×
Exterior lamp	HEAD LAMP	×	×	×
Wiper and washer	WIPER	×	×	×
Turn signal and hazard warning lamps	FLASHER	×	×	×
—	AIR CONDITONER*		×	×
<ul style="list-style-type: none"> Intelligent Key system Engine start system 	INTELLIGENT KEY	×	×	×
Combination switch	COMB SW		×	
Body control system	BCM	×		
IVIS	IMMU	×	×	×
Interior room lamp battery saver	BATTERY SAVER	×	×	×
Back door	TRUNK		×	
Vehicle security system	THEFT ALM	×	×	×
RAP system	RETAINED PWR		×	
Signal buffer system	SIGNAL BUFFER		×	×
—	AIR PRESSURE MONITOR*	×	×	×

*: This item is indicated, but not used.

FREEZE FRAME DATA (FFD)

The BCM records the following vehicle condition at the time a particular DTC is detected, and displays on CONSULT.

DIAGNOSIS SYSTEM (BCM)

< SYSTEM DESCRIPTION >

CONSULT screen item	Indication/Unit	Description	
Vehicle Speed	km/h	Vehicle speed of the moment a particular DTC is detected	
Odo/Trip Meter	km	Total mileage (Odometer value) of the moment a particular DTC is detected	
Vehicle Condition	SLEEP>LOCK	Power position status of the moment a particular DTC is detected	While turning BCM status from low power consumption mode to normal mode (Power supply position is "LOCK")
	SLEEP>OFF		While turning BCM status from low power consumption mode to normal mode (Power supply position is "OFF".)
	LOCK>ACC		While turning power supply position from "LOCK" to "ACC"
	ACC>ON		While turning power supply position from "ACC" to "IGN"
	RUN>ACC		While turning power supply position from "RUN" to "ACC" (Vehicle is stopping and selector lever is except P position.)
	CRANK>RUN		While turning power supply position from "CRANKING" to "RUN" (From cranking up the engine to run it)
	RUN>URGENT		While turning power supply position from "RUN" to "ACC" (Emergency stop operation)
	ACC>OFF		While turning power supply position from "ACC" to "OFF"
	OFF>LOCK		While turning power supply position from "OFF" to "LOCK"
	OFF>ACC		While turning power supply position from "OFF" to "ACC"
	ON>CRANK		While turning power supply position from "IGN" to "CRANKING"
	OFF>SLEEP		While turning BCM status from normal mode (Power supply position is "OFF".) to low power consumption mode
	LOCK>SLEEP		While turning BCM status from normal mode (Power supply position is "LOCK".) to low power consumption mode
	LOCK		Power supply position is "LOCK" (Ignition switch OFF with steering is locked.)
	OFF		Power supply position is "OFF" (Ignition switch OFF with steering is unlocked.)
	ACC		Power supply position is "ACC" (Ignition switch ACC)
ON	Power supply position is "IGN" (Ignition switch ON with engine stopped)		
ENGINE RUN	Power supply position is "RUN" (Ignition switch ON with engine running)		
CRANKING	Power supply position is "CRANKING" (At engine cranking)		
IGN Counter	0 - 39	The number of times that ignition switch is turned ON after DTC is detected <ul style="list-style-type: none"> • The number is 0 when a malfunction is detected now. • The number increases like 1 → 2 → 3...38 → 39 after returning to the normal condition whenever ignition switch OFF → ON. • The number is fixed to 39 until the self-diagnosis results are erased if it is over 39. 	

RETAINED PWR

RETAINED PWR : CONSULT Function (BCM - RETAINED PWR)

INFOID:000000009009725

Data monitor

NOTE:

The following table includes information (items) inapplicable to this vehicle. For information (items) applicable to this vehicle, refer to CONSULT display items.

Monitor Item	Description
DOOR SW-DR	Indicates [ON/OFF] condition of driver side door switch.
DOOR SW-AS	Indicates [ON/OFF] condition of passenger side door switch.

BCM (BODY CONTROL MODULE)

< ECU DIAGNOSIS INFORMATION >

ECU DIAGNOSIS INFORMATION

BCM (BODY CONTROL MODULE)

List of ECU Reference

INFOID:000000009009726

ECU	Reference
BCM	BCS-35, "Reference Value"
	BCS-56, "Fail-safe"
	BCS-57, "DTC Inspection Priority Chart"
	BCS-57, "DTC Index"

POWER WINDOW MAIN SWITCH

< ECU DIAGNOSIS INFORMATION >

POWER WINDOW MAIN SWITCH

Reference Value

INFOID:000000009009727

TERMINAL LAYOUT

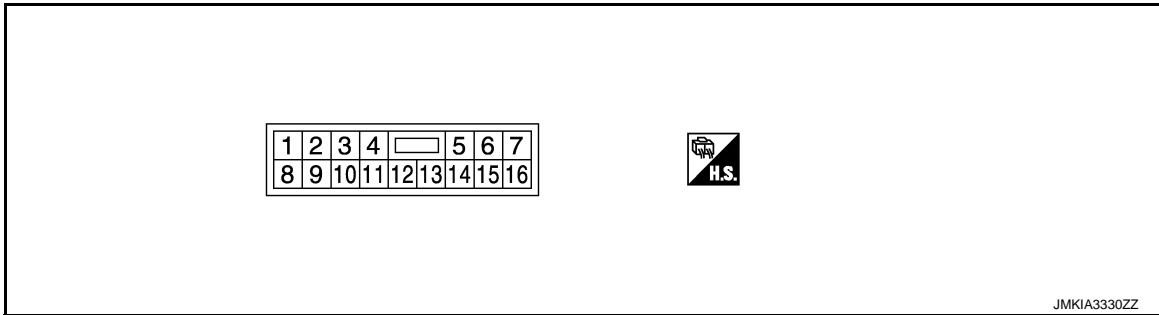

PHYSICAL VALUES

POWER WINDOW MAIN SWITCH

Terminal No. (wire color)		Description		Condition	Voltage [V] (Approx.)
+	-	Signal name	Input/ Output		
3 (G/R)	Ground	Encoder power supply	Output	When ignition switch ON or power window timer op- erates.	12
4 (W)	Ground	Battery power supply	Input	—	12
5 (G)	Ground	Front driver side power win- dow motor DOWN signal	Output	When front LH switch in power window main switch is operated DOWN	12
6 (L)	Ground	Front driver side power win- dow motor UP signal	Output	When front LH switch in power window main switch is operated UP	12
7 (B)	Ground	Ground	—	—	0
9 (Y)	Ground	Retained power signal	Input	IGN SW ON	12
				Within 45 second after ig- nition switch is turned to OFF	12
				When driver side or pas- senger side door is opened during retained power operation	0
10 (W/B)	Ground	Encoder ground	—	—	0
11 (G/Y)	Ground	Encoder pulse signal 1	Input	When power window mo- tor operates.	

JMKIA0070GB

A
B
C
D
E
F
G
H
I
J
L
M
N
O
P

PWC

POWER WINDOW MAIN SWITCH

< ECU DIAGNOSIS INFORMATION >

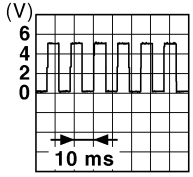
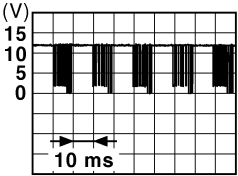
Terminal No. (wire color)		Description		Condition	Voltage [V] (Approx.)
+	-	Signal name	Input/ Output		
12 (G/W)	Ground	Encoder pulse signal 2	Input	When power window motor operates.	 <small>JMKIA0070GB</small>
13 (V)	Ground	Power window serial link	Input/ Output	IGN SW ON or power window timer operating.	 <small>JPMIA0013GB</small>
15 (R)	Ground	Door key cylinder switch LOCK signal	Input	Key position (Neutral →Locked)	5 → 0
16 (W)	Ground	Door key cylinder switch UN-LOCK signal	Input	Key position (Neutral →Unlocked)	5 → 0

Fail-safe

INFOID:00000000909728

FAIL-SAFE CONTROL

Switches to fail-safe control when malfunction is detected in encoder signal that detects up/down speed and direction of door glass. Switches to fail-safe control when a signal that is out of the specified value is detected between the fully closed position and the actual position of the glass.

Malfunction	Malfunction condition
Pulse sensor malfunction	When one pulse signal that is the specified value or more is detected continuously for the specified time or more, while door glass is being operated UP or DOWN.
Both pulse sensors malfunction	When both pulse signals are not detected continuously for the specified time or more, while door glass is being operated UP or DOWN.
Pulse direction malfunction	When a pulse signal indicating that window is moving in the opposite direction against the power window motor is detected for the specified value or more, while door glass is being operated UP or DOWN.
Glass recognition position malfunction 1	When the actual door glass position that is out of specified value is detected compared to the door glass fully closed position memorized in module, while door glass is being operated UP or DOWN.
Glass recognition position malfunction 2	When pulse count that is out of the door glass full stroke value or more is detected, while door glass is being operated UP or DOWN.

If fail-safe control, the system changes to a non-initialized condition and the following function do not operate.

- Auto-up operation
- Anti-pinch function
- Retained power function

When fail-safe control is activated, perform the initialization procedure to recover. However, if a malfunction is still detected in power window switch, the fail-safe control is activated again.

FRONT POWER WINDOW SWITCH (PASSENGER SIDE)

< ECU DIAGNOSIS INFORMATION >

FRONT POWER WINDOW SWITCH (PASSENGER SIDE)

Reference Value

INFOID:000000009009729

TERMINAL LAYOUT

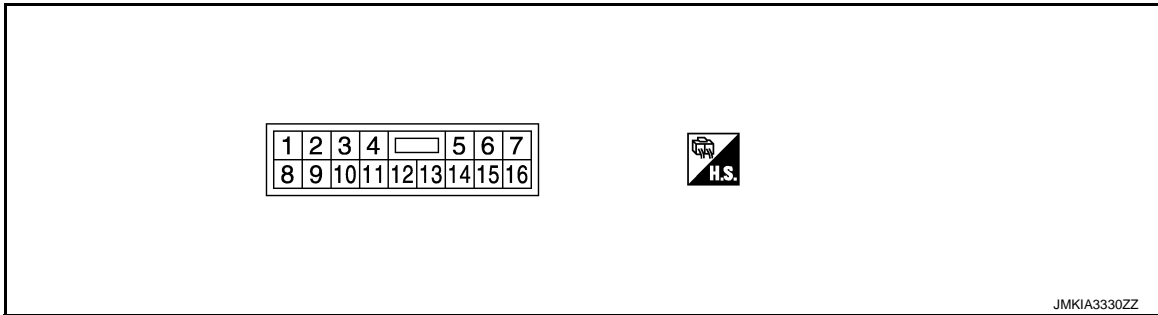

PHYSICAL VALUES

FRONT POWER WINDOW SWITCH

Terminal No. (wire color)		Description		Condition	Voltage [V] (Approx.)
+	-	Signal name	Input/ Output		
3 (W/B)	Ground	Encoder ground	—	—	0
4 (G/R)	Ground	Encoder power supply	Output	When ignition switch ON or power window timer operates	12
8 (L)	Ground	Power window motor UP signal	Output	When power window motor is operated UP	12
9 (G)	Ground	Power window motor DOWN signal	Output	When power window motor is operated DOWN	12
10 (W)	Ground	Battery power supply	Input	—	12
11 (B)	Ground	Ground	—	—	0
12 (G/Y)	Ground	Encoder pulse signal 1	Input	When power window motor operates	

JMKIA0070GB

A
B
C
D
E
F
G
H
I
J
L
M
N
O
P

PWC

FRONT POWER WINDOW SWITCH (PASSENGER SIDE)

< ECU DIAGNOSIS INFORMATION >

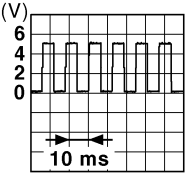
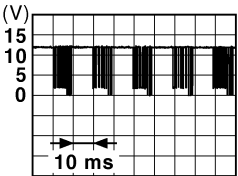
Terminal No. (wire color)		Description		Condition	Voltage [V] (Approx.)
+	-	Signal name	Input/ Output		
15 (G/W)	Ground	Encoder pulse signal 2	Input	When power window motor operates	 <p style="text-align: right; font-size: small;">JMKIA0070GB</p>
16 (V)	Ground	Power window serial link	Input/ Output	When ignition switch ON or power window timer operates	 <p style="text-align: right; font-size: small;">JPMIA0013GB</p>

Fail-safe

INFOID:00000000909730

FAIL-SAFE CONTROL

Switches to fail-safe control when malfunction is detected in encoder signal that detects up/down speed and direction of door glass. Switches to fail-safe control when a signal that is out of the specified value is detected between the fully closed position and the actual position of the glass.

Malfunction	Malfunction condition
Pulse sensor malfunction	When one pulse signal that is the specified value or more is detected continuously for the specified time or more, while door glass is being operated UP or DOWN.
Both pulse sensors malfunction	When both pulse signals are not detected continuously for the specified time or more, while door glass is being operated UP or DOWN.
Pulse direction malfunction	When a pulse signal indicating that window is moving in the opposite direction against the power window motor is detected for the specified value or more, while door glass is being operated UP or DOWN.
Glass recognition position malfunction 1	When the actual door glass position that is out of specified value is detected compared to the door glass fully closed position memorized in module, while door glass is being operated UP or DOWN.
Glass recognition position malfunction 2	When pulse count that is out of the door glass full stroke value or more is detected, while door glass is being operated UP or DOWN.

If fail-safe control, the system changes to a non-initialized condition and the following function do not operate.

- Auto-up operation
- Anti-pinch function
- Retained power function

When fail-safe control is activated, perform the initialization procedure to recover. However, if a malfunction is still detected in power window switch, the fail-safe control is activated again.

REAR POWER WINDOW SWITCH LH

< ECU DIAGNOSIS INFORMATION >

REAR POWER WINDOW SWITCH LH

Reference Value

INFOID:000000009009731

TERMINAL LAYOUT

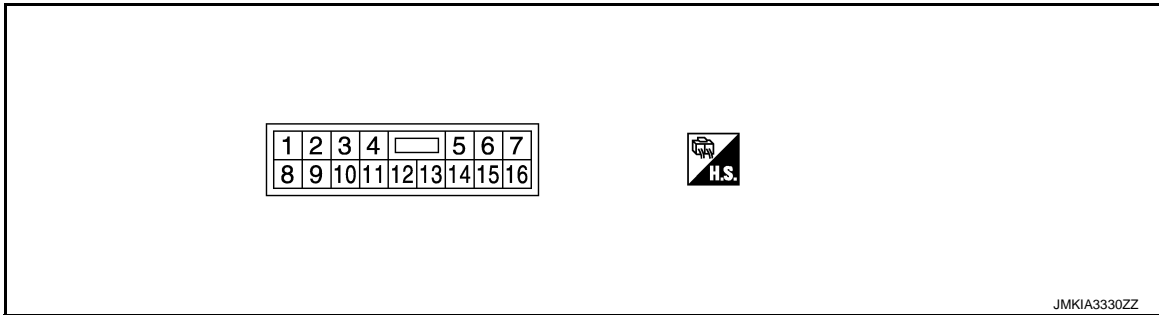

PHYSICAL VALUES

REAR POWER WINDOW SWITCH

Terminal No. (wire color)		Description		Condition	Voltage [V] (Approx.)
+	-	Signal name	Input/ Output		
3 (SB)	Ground	Encoder ground	—	—	0
4 (LG)	Ground	Encoder power supply	Output	When ignition switch ON or power window timer operates	12
8 (Y)	Ground	Power window motor UP signal	Output	When power window motor is operated UP	12
9 (G)	Ground	Power window motor DOWN signal	Output	When power window motor is operated DOWN	12
10 (W)	Ground	Battery power supply	Input	—	12
11 (B)	Ground	Ground	—	—	0
12 (BR)	Ground	Encoder pulse signal 1	Input	When power window motor operates	

JMKIA0070GB

A
B
C
D
E
F
G
H
I
J
L
M
N
O
P

PWC

REAR POWER WINDOW SWITCH LH

< ECU DIAGNOSIS INFORMATION >

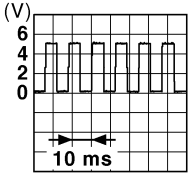
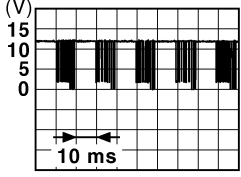
Terminal No. (wire color)		Description		Condition	Voltage [V] (Approx.)
+	-	Signal name	Input/ Output		
15 (L)	Ground	Encoder pulse signal 2	Input	When power window motor operates.	 JMKIA0070GB
16 (V)	Ground	Power window serial link	Input/ Output	When ignition switch ON or power window timer operates	 JPMIA0013GB

Fail-safe

INFOID:00000000909732

FAIL-SAFE CONTROL

Switches to fail-safe control when malfunction is detected in encoder signal that detects up/down speed and direction of door glass. Switches to fail-safe control when a signal that is out of the specified value is detected between the fully closed position and the actual position of the glass.

Malfunction	Malfunction condition
Pulse sensor malfunction	When one pulse signal that is the specified value or more is detected continuously for the specified time or more, while door glass is being operated UP or DOWN.
Both pulse sensors malfunction	When both pulse signals are not detected continuously for the specified time or more, while door glass is being operated UP or DOWN.
Pulse direction malfunction	When a pulse signal indicating that window is moving in the opposite direction against the power window motor is detected for the specified value or more, while door glass is being operated UP or DOWN.
Glass recognition position malfunction 1	When the actual door glass position that is out of specified value is detected compared to the door glass fully closed position memorized in module, while door glass is being operated UP or DOWN.
Glass recognition position malfunction 2	When pulse count that is out of the door glass full stroke value or more is detected, while door glass is being operated UP or DOWN.

If fail-safe control, the system changes to a non-initialized condition and the following function do not operate.

- Auto-up operation
- Anti-pinch function
- Retained power function

When fail-safe control is activated, perform the initialization procedure to recover. However, if a malfunction is still detected in power window switch, the fail-safe control is activated again.

REAR POWER WINDOW SWITCH RH

< ECU DIAGNOSIS INFORMATION >

REAR POWER WINDOW SWITCH RH

Reference Value

INFOID:000000009009733

TERMINAL LAYOUT

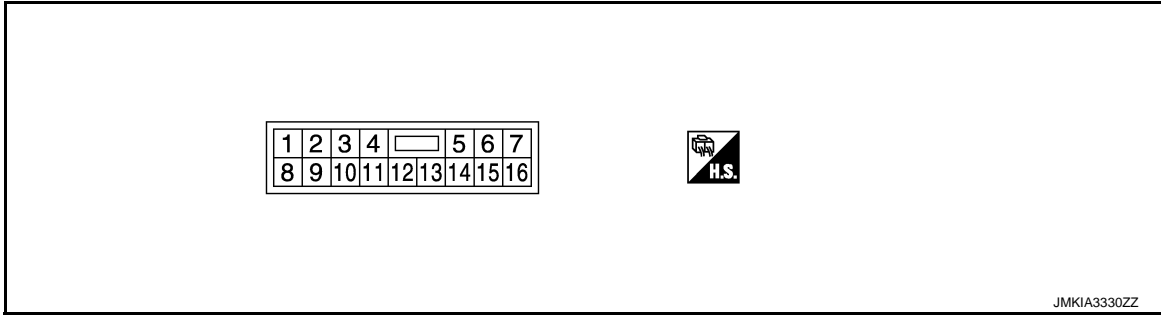

PHYSICAL VALUES

REAR POWER WINDOW SWITCH

Terminal No. (wire color)		Description		Condition	Voltage [V] (Approx.)
+	-	Signal name	Input/ Output		
3 (P)	Ground	Encoder ground	—	—	0
4 (Y)	Ground	Encoder power supply	Output	When ignition switch ON or power window timer operates	12
8 (W/R)	Ground	Power window motor UP signal	Output	When power window motor is operated UP	12
9 (R)	Ground	Power window motor DOWN signal	Output	When power window motor is operated DOWN	12
10 (W)	Ground	Battery power supply	Input	—	12
11 (B)	Ground	Ground	—	—	0
12 (O)	Ground	Encoder pulse signal 1	Input	When power window motor operates	

JMKIA0070GB

A
B
C
D
E
F
G
H
I
J
L
M
N
O
P

PWC

REAR POWER WINDOW SWITCH RH

< ECU DIAGNOSIS INFORMATION >

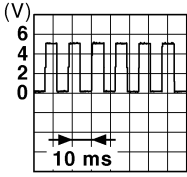
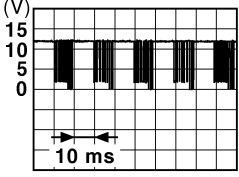
Terminal No. (wire color)		Description		Condition	Voltage [V] (Approx.)
+	-	Signal name	Input/ Output		
15 (G)	Ground	Encoder pulse signal 2	Input	When power window motor operates.	 JMKIA0070GB
16 (V)	Ground	Power window serial link	Input/ Output	When ignition switch ON or power window timer operates	 JPMIA0013GB

Fail-safe

INFOID:00000000909734

FAIL-SAFE CONTROL

Switches to fail-safe control when malfunction is detected in encoder signal that detects up/down speed and direction of door glass. Switches to fail-safe control when a signal that is out of the specified value is detected between the fully closed position and the actual position of the glass.

Malfunction	Malfunction condition
Pulse sensor malfunction	When one pulse signal that is the specified value or more is detected continuously for the specified time or more, while door glass is being operated UP or DOWN.
Both pulse sensors malfunction	When both pulse signals are not detected continuously for the specified time or more, while door glass is being operated UP or DOWN.
Pulse direction malfunction	When a pulse signal indicating that window is moving in the opposite direction against the power window motor is detected for the specified value or more, while door glass is being operated UP or DOWN.
Glass recognition position malfunction 1	When the actual door glass position that is out of specified value is detected compared to the door glass fully closed position memorized in module, while door glass is being operated UP or DOWN.
Glass recognition position malfunction 2	When pulse count that is out of the door glass full stroke value or more is detected, while door glass is being operated UP or DOWN.

If fail-safe control, the system changes to a non-initialized condition and the following function do not operate.

- Auto-up operation
- Anti-pinch function
- Retained power function

When fail-safe control is activated, perform the initialization procedure to recover. However, if a malfunction is still detected in power window switch, the fail-safe control is activated again.

POWER WINDOW SYSTEM

< WIRING DIAGRAM >

WIRING DIAGRAM

POWER WINDOW SYSTEM

Wiring Diagram

INFOID:000000009009735

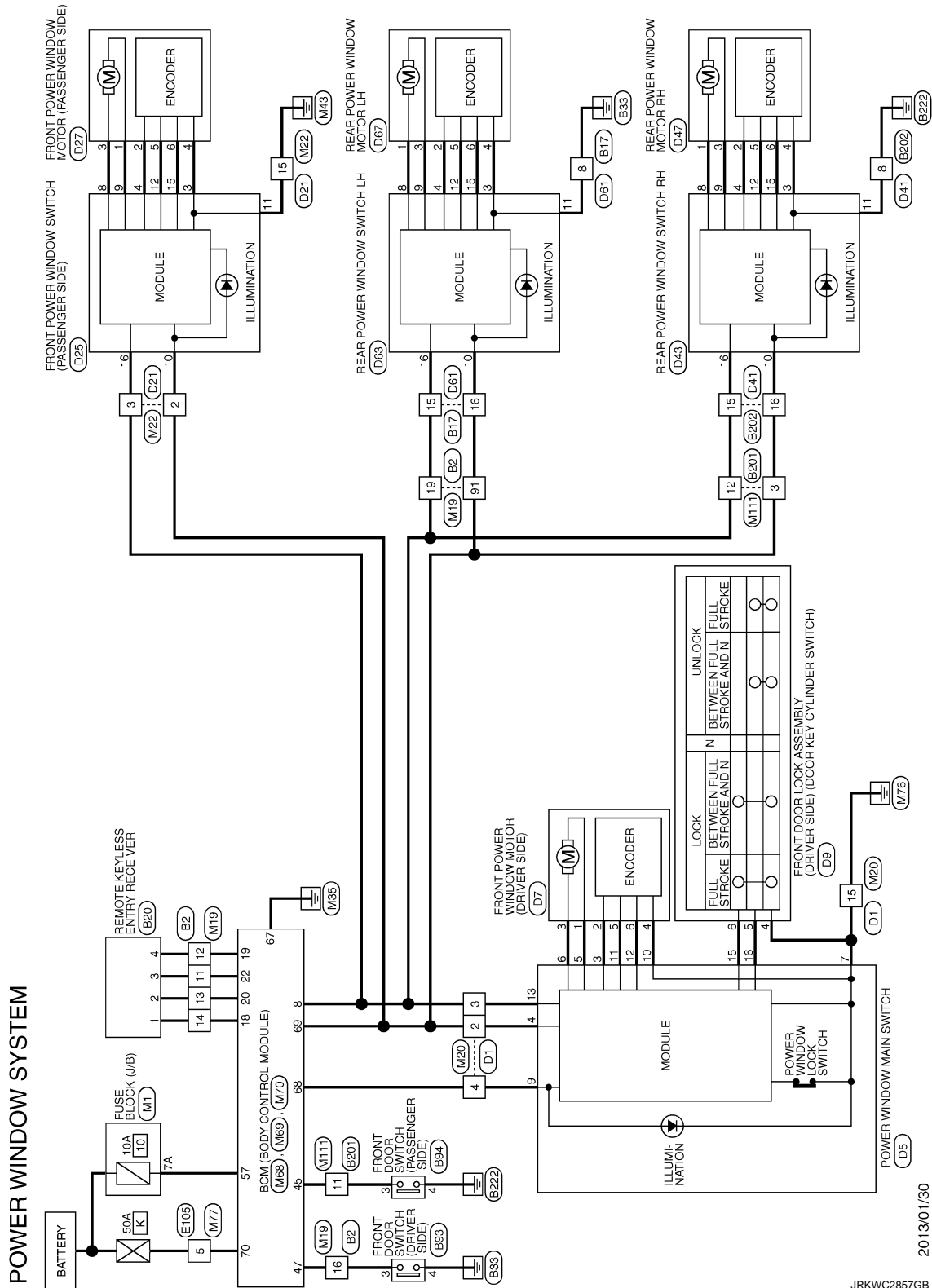

2013/01/30

JRKWC2857G

A
B
C
D
E
F
G
H
I
J
K
L
M
N
O
P



POWER WINDOW SYSTEM

< WIRING DIAGRAM >

POWER WINDOW SYSTEM

Connector No.	B2
Connector Name	WIRE TO WIRE
Connector Type	TH80MW-CS16-TM4



Terminal No.	Color Of Wire	Signal Name [Specification]
2	L	-
3	BR	-
5	R/W	-
6	V	-
7	G	-
11	W/B	-
12	BR	-
13	G/R	-
14	B/Y	-
15	W/R	-
16	GR/R	-
18	GW	-
19	V	-
20	W/G	-
21	B/W	-
22	V	-
24	G	-
25	O	-
26	Y	-
27	L/O	-
28	Y/R	-
29	L	-
30	R	-
31	G/Y	-
32	B/SB	-
33	LG/R	-
34	BR/W	-
35	GR/R	-
36	SB	-
37	LG	-
38	L	-
39	P	-
40	W/G	-
41	O	-

42	G/R	-
43	V/W	-
44	LG/B	-
45	R/Y	-
46	B	-
47	BR	-
49	GR	-
50	R/B	-
51	W/R	-
52	BR/Y	-
53	O/B	-
54	G/O	-
55	R/B	-
56	LG/R	-
57	GR/R	-
58	Y/G	-
59	V/W	-
60	R	-
63	R	-
64	R	-
65	W	-
66	G	-
67	SHIELD	-
69	LG/B	-
70	P/L	-
71	L	-
72	R	-
77	Y/B	-
78	Y/L	-
79	Y	-
80	W/R	-
81	Y/L	-
84	L/O	-
86	O	-
87	W/R	-
88	O	-
89	W/L	-
90	GR/L	-
91	W	-
92	G	-
94	W/R	-
96	L/W	-
97	R	-
98	V	-
99	L/W	-
100	P/B	-

Connector No.	B17
Connector Name	WIRE TO WIRE
Connector Type	NS16FM-CS

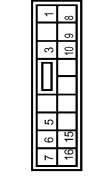

Terminal No.	Color Of Wire	Signal Name [Specification]
1	W/R	-
3	G	-
5	R	-
6	L/O	-
7	O	-
8	B	-
9	L	-
10	R/Y	-
15	V	-
16	W	-

Connector No.	B20
Connector Name	REMOTE KEYLESS ENTRY RECEIVER
Connector Type	TK04FY



Terminal No.	Color Of Wire	Signal Name [Specification]
1	BR	-
2	W/B	-
3	G/R	-
4	B/Y	-

Connector No.	B83
Connector Name	FRONT DOOR SWITCH (DRIVER SIDE)
Connector Type	TH04FW-NH



Terminal No.	Color Of Wire	Signal Name [Specification]
3	GR/R	DOOR_SW_DR
4	B	GND

Connector No.	B84
Connector Name	FRONT DOOR SWITCH (PASSENGER SIDE)
Connector Type	TH04FW-NH



Terminal No.	Color Of Wire	Signal Name [Specification]
3	W	DOOR_SW_AS
4	B	GND

JRKWC5519GB

POWER WINDOW SYSTEM

< WIRING DIAGRAM >

POWER WINDOW SYSTEM

Connector No.	B201
Connector Name	WIRE TO WIRE
Connector Type	TH40FW-CS16-TM4

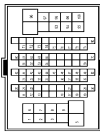

Terminal No.	Color Of Wire	Signal Name [Specification]
1	R/B	-
2	G	-
3	W	-
5	W/B	-
6	P/Y	-
7	R	-
8	G/R	-
9	G/R/R	-
11	W	-
12	V	-
13	Y	-
16	L/O	-
17	GR/L	-
18	R/G	-
19	L/Y	-
20	G/Y	-
21	R	-
22	GR	-
27	L/W	-
29	W	-
30	R/L	-
31	Y/L	-
32	W/R	-
33	W/G	-
34	L/R	-
36	G	-
37	V	-
38	SHIELD	-
39	P/B	-
40	W/R	-
41	R	-
42	L	-
43	B/W	-
44	L	-
45	P	-
46	SHIELD	-

POWER WINDOW SYSTEM

Connector No.	B202
Connector Name	WIRE TO WIRE
Connector Type	NS18FW-CS

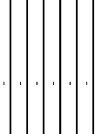

Terminal No.	Color Of Wire	Signal Name [Specification]
47	R	-
48	W	-
49	SHIELD	-
50	V	-
51	L/B	-
52	L/R	-
53	S/B	-
54	V/W	-
59	L	-
60	GR	-
61	P/L	-
62	B/SB	-
63	R/Y	-
64	BR	-
70	O	-
71	W	-
72	SHIELD	-
73	B	-
74	R	-
75	G	-
76	Y	-
77	S/B	-
78	L/G	-
79	R/B	-
90	W/B	-
93	Y	-
94	L	-
95	L/R	-
96	R	-
97	W	-
98	V	-
99	L/W	-
100	W	-

POWER WINDOW SYSTEM

Connector No.	D1
Connector Name	WIRE TO WIRE
Connector Type	TH40FW-CS15

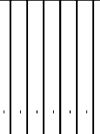

Terminal No.	Color Of Wire	Signal Name [Specification]
1	V	-
2	W	-
3	V	-
4	Y	-
5	L/G/R	-
6	BR/W	-
8	V	-
9	G	-
10	L	-
12	B/Y	-
13	Y	-
14	R	-
15	B	-
16	GR/R	-
17	R/W	-
18	B	-
19	B	-
20	P	-
22	V	-
23	P/B	-
24	L/O	-
25	BR/W	-

POWER WINDOW SYSTEM

Connector No.	D5
Connector Name	POWER WINDOW MAIN SWITCH
Connector Type	NS18FW-CS

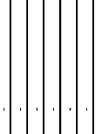

Terminal No.	Color Of Wire	Signal Name [Specification]
26	W/R	-
27	V	-
28	W/G	-
29	Y/G	-
30	O/L	-
31	GR/B	-
32	BR	-
33	V/W	-
36	G/O	-
37	BR/Y	-
38	S/B	-
39	W/L	-
40	L/W	-
41	Y/G	-
42	P/L	-
43	L/G	-
44	GR/L	-
45	SHIELD	-
46	W	-
47	LG	-
48	G/W	-
49	Y	-
50	L/Y	-
51	G/R/R	-
52	L/G/B	-
53	G	-
54	B	-
55	R	-

A
B
C
D
E
F
G
H
I
J
PWC
L
M
N
O
P

JRKWC5520GB

POWER WINDOW SYSTEM

< WIRING DIAGRAM >

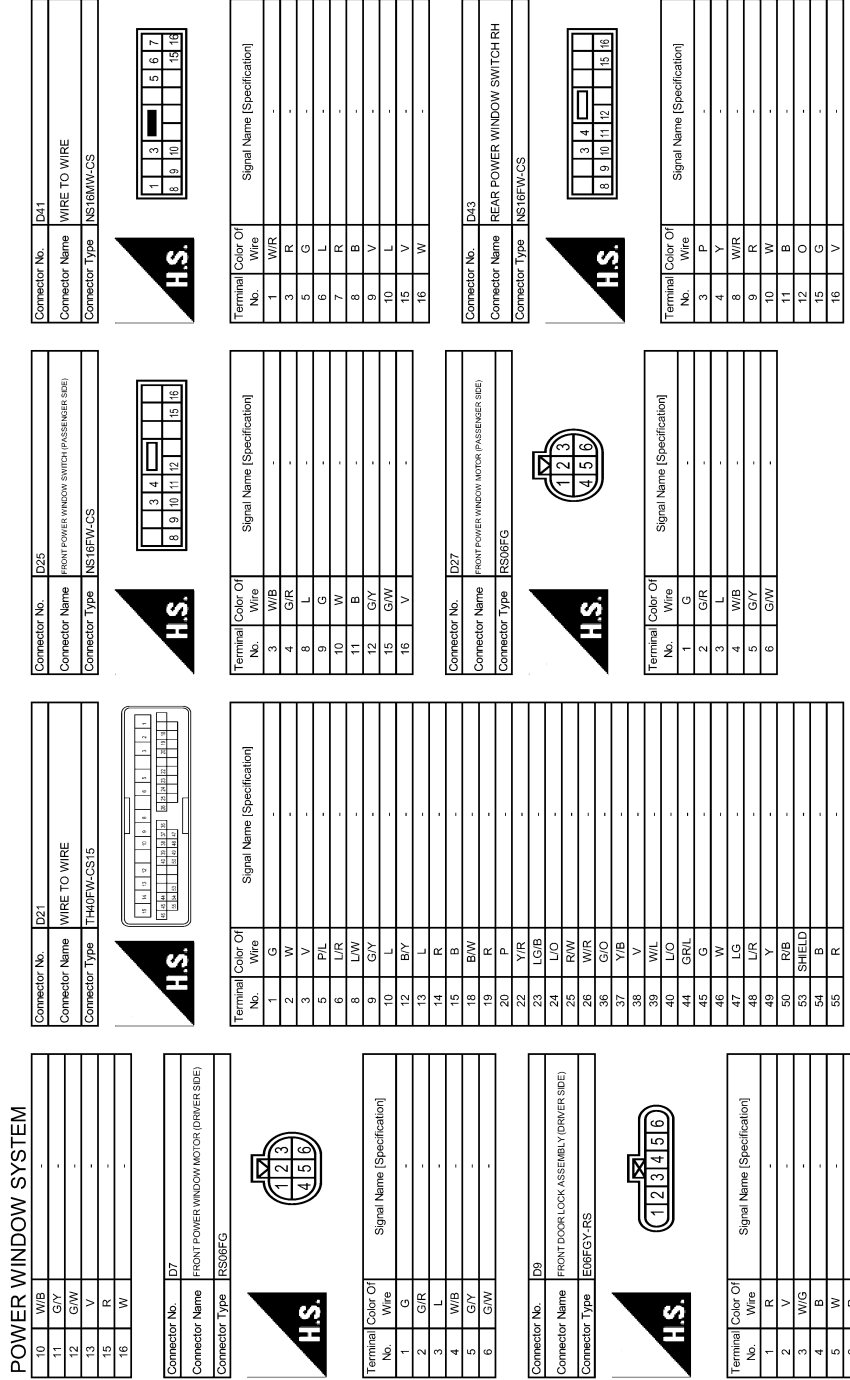

JRKWC5521GB

POWER WINDOW SYSTEM

< WIRING DIAGRAM >

POWER WINDOW SYSTEM

Connector No.	D67
Connector Name	REAR POWER WINDOW MOTOR RH
Connector Type	RS16FG



Terminal No.	Color Of Wire	Signal Name [Specification]
1	W/R	-
2	Y	-
3	R	-
4	B	-
5	O	-
6	G	-

Connector No.	D61
Connector Name	WIRE TO WIRE
Connector Type	NS16MW-CS

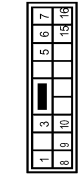

Terminal No.	Color Of Wire	Signal Name [Specification]
1	W/R	-
3	G	-
5	R	-
6	L/O	-
7	O	-
8	B	-
9	L	-
10	R/Y	-
15	V	-
16	W	-

Connector No.	D63
Connector Name	REAR POWER WINDOW SWITCH LH
Connector Type	NS16FW-CS

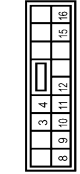

Terminal No.	Color Of Wire	Signal Name [Specification]
3	SB	-
4	LG	-
8	Y	-
9	G	-
10	W	-
11	B	-
12	BR	-
15	L	-
16	V	-

Connector No.	D67
Connector Name	REAR POWER WINDOW MOTOR LH
Connector Type	RS16FG



Terminal No.	Color Of Wire	Signal Name [Specification]
1	Y	-
2	LG	-
3	G	-
4	SB	-
5	BR	-
6	L	-

Connector No.	E105
Connector Name	WIRE TO WIRE
Connector Type	TH80MW-CS16-TM4



Terminal No.	Color Of Wire	Signal Name [Specification]
1	L	-
2	L/W	-
3	RB	-
4	L	-
5	Y	-
7	W/G	-
8	P/B	-
9	W/B	-
10	G	-
11	L	-
12	P	-
13	P/B	-
14	BR	-
15	L/B	-
16	SB	-
18	BR	-
19	Y/G	-
20	B/Y	-
21	Y/V	-
22	L	-
23	Y	-
24	L/W	-
28	O	-
29	R/W	-
30	L/B	-
31	Y	-
32	GR/R	-
34	Y	-
35	R	-
36	B/R	-
37	G/Y	-
38	G	-
40	SB	-
41	W/R	-
42	R	-
43	V	-

51	L/O	-
52	BR/W	-
53	BR/Y	-
54	GR/L	-
60	W	-
61	B	-
62	R	-
63	G	-
64	SHIELD	-
91	BR	-
92	L/W	-
94	Y/B	-
95	G/R	-
97	R	-
98	G/B	-
100	W/R	-

Connector No.	M1
Connector Name	FUSE BLOCK (J/B)
Connector Type	NS26FW-M2

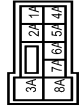

Terminal No.	Color Of Wire	Signal Name [Specification]
1A	Y	-
2A	GR	-
3A	W	-
4A	Y/G	-
5A	V	-
6A	L/W	-
7A	LG	-
8A	W	-

JRKWC5522GB

A
B
C
D
E
F
G
H
I
J
K
L
M
N
O
P

PWC

POWER WINDOW SYSTEM

< WIRING DIAGRAM >

POWER WINDOW SYSTEM

Connector No.	M19
Connector Name	WIRE TO WIRE
Connector Type	TH88FW-CS16-TM4



Terminal No.	Color Of Wire	Signal Name [Specification]
2	L	-
3	BR	-
5	RYW	-
6	V	-
7	G	-
9	W/B	-
12	BR	-
13	GR	-
14	B/Y	-
15	WR	-
16	GR/R	-
18	GW	-
19	V	-
20	WG	-
21	BW	-
22	V	-
24	G	-
25	O	-
26	Y	-
27	L/O	-
28	Y/R	-
29	L	-
30	R	-
31	G/Y	-
32	B/SB	-
33	LG/R	-
34	BRW	-
35	GR/R	-
36	SB	-
37	LG	-
38	L	-
39	P	-
40	WG	-
41	O	-
42	GR	-

43	V/W	-
44	LG/B	-
45	R/Y	-
46	B	-
47	BRW	-
49	GR	-
50	R/B	-
51	W/R	-
52	BR/Y	-
53	O/B	-
54	G/O	-
55	R/B	-
56	LG/R	-
57	GR/R	-
58	Y/G	-
59	V/W	-
60	R	-
63	B	-
64	R	-
65	W	-
66	G	-
67	SHIELD	-
69	LG/B	-
70	P/L	-
71	L	-
72	R	-
77	Y/B	-
78	Y/L	-
79	Y	-
80	WR	-
81	Y/L	-
84	L/O	-
86	O	-
87	W/R	-
88	O	-
89	W/L	-
90	GR/L	-
91	W	-
92	G	-
94	W/R	-
96	L/W	-
97	R	-
98	V	-
99	L/W	-
100	P/B	-

Connector No.	M20
Connector Name	WIRE TO WIRE
Connector Type	TH40MW-CS15

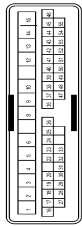

Terminal No.	Color Of Wire	Signal Name [Specification]
1	V	-
2	W	-
3	V	-
4	Y	-
5	LG/R	-
6	BRW	-
8	V	-
9	G	-
10	L	-
12	B/Y	-
13	Y	-
14	R	-
15	B	-
16	GR/R	-
17	V/W	-
18	B	-
19	R	-
20	P	-
22	V	-
23	P/B	-
24	L/O	-
25	BRW	-
26	W/R	-
27	V	-
28	W/G	-
29	Y/G	-
30	O/L	-
31	GR/B	-
32	BR	-
33	V/W	-
36	G/O	-
37	BR/Y	-
38	SB	-
39	W/L	-
40	L/W	-
41	Y/G	-

42	P/L	-
43	LG	-
44	GR	-
45	SHIELD	-
46	W	-
47	LG	-
48	GW	-
49	Y	-
50	L/Y	-
51	GR/R	-
52	LG/B	-
53	G	-
54	B	-
55	R	-

Connector No.	M22
Connector Name	WIRE TO WIRE
Connector Type	TH40MW-CS15

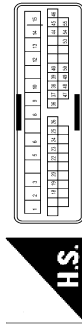

Terminal No.	Color Of Wire	Signal Name [Specification]
1	G	-
2	W	-
3	V	-
5	P/L	-
6	L/R	-
8	L/W	-
9	G/Y	-
10	L	-
12	B/Y	-
13	L	-
14	R	-
15	B	-
18	B/W	-
19	R	-
20	P	-
22	Y/R	-
23	LG/B	-
24	L/W	-
25	W/R	-
26	W/R	-

JRKWC5523GB

POWER WINDOW SYSTEM

< WIRING DIAGRAM >

POWER WINDOW SYSTEM

36	G/O	-	INTELLIGENT KEY IDENTIFICATION
37	Y/B	-	HAZARD SW
29	W	W/L	BK DOOR OPNR SW
30	W/L	-	DR DOOR UNLOCK SW
31	W/G	-	COMBI SW OUTPUT 5
32	LG	-	COMBI SW OUTPUT 4
33	Y	-	COMBI SW OUTPUT 3
34	W	-	COMBI SW OUTPUT 2
35	R/W	-	COMBI SW OUTPUT 1
36	SB	-	SHIFT P
47	LG	-	CANH
48	L/R	-	CANH
49	Y	-	CANH
50	R/B	-	CANH
53	SHIELD	-	CANH
54	B	-	CANH
55	R	-	CANH

Connector No. M68
 Connector Name BCM (BODY CONTROL MODULE)
 Connector Type TH40FB-NH

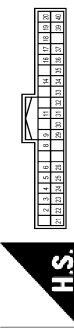

Terminal No.	Color Of Wire	Signal Name (Specification)
2	BRY	COMBI SW INPUT 5
3	GR	COMBI SW INPUT 4
4	L	COMBI SW INPUT 3
5	G	COMBI SW INPUT 2
6	V	COMBI SW INPUT 1
8	V	POWER WINDOW SW COMM
9	R	STOP LAMP SW 1
11	R	RAIN SENSOR SERIAL LINK
14	P/B	OPTICAL SENSOR
16	L/O	DIMMER SIGNAL
17	Y/G	SENSOR PWR SPLY
18	BY	RECEIVER/SENSOR GND
19	BR	RECEIVER PWR SPLY
20	GR	KYLS ENT RECEIVER COMM
21	P	NATS ANT AMPS
22	W/B	KYLS ENT RECEIVER RSSI
23	GR/R	SECURITY IND CONT
24	SB	DONGLE LINK
25	LG/R	NATS ANT AMP

26	O	INTELLIGENT KEY IDENTIFICATION
29	W	HAZARD SW
30	W/L	BK DOOR OPNR SW
31	W/G	DR DOOR UNLOCK SW
32	LG	COMBI SW OUTPUT 5
33	Y	COMBI SW OUTPUT 4
34	W	COMBI SW OUTPUT 3
35	R/W	COMBI SW OUTPUT 2
36	SB	COMBI SW OUTPUT 1
37	G/Y	SHIFT P
39	L	CANH
40	P	CANH

Connector No. M69
 Connector Name BCM (BODY CONTROL MODULE)
 Connector Type FE409FB-FH46-SA

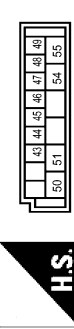

Terminal No.	Color Of Wire	Signal Name (Specification)
43	Y/L	BK DOOR SW
44	G/W	REAR WIPER STOP POSITION
45	W	PASSENGER DOOR SW
46	GR	REAR RH DOOR SW
47	GR/R	DRIVER DOOR SW
48	O	REAR LH DOOR SW
49	BRY	LUGGAGE ROOM LAMP CONT
50	BY	REMOTE ENGINE START
51	W/R	BACK DOOR REQ SW
54	L	REAR WIPER OUTPUT
55	G	REAR DOOR UNLK OUTPUT

Connector No. M70
 Connector Name BCM (BODY CONTROL MODULE)
 Connector Type FE409FW-FH46-SA

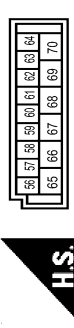

Terminal No.	Color Of Wire	Signal Name (Specification)
56	W/R	INT ROOM LAMP PWR SPLY
57	LG	BAT (FUSE)
58	R/W	SHOCK DETECT SENS
59	G	PASSENGER DOOR UNLK OUTPUT
60	G	TURN SIGNAL LH OUTPUT
61	G/Y	TURN SIGNAL RH OUTPUT
62	R	STEP LAMP CONT
63	BR	ROOM LAMP-TIMER CONT
64	GR/R	CRANKING REQUEST
65	R	ALL DOOR LOCK OUTPUT
66	V	DR DOOR FUEL LID UNLK OUTPUT
67	B	GND
68	Y	PW PWR SPLY (IGN)
69	W	PW PWR SPLY (BAT)
70	Y	BAT (F/L)

Connector No. M77
 Connector Name WIRE TO WIRE
 Connector Type TH80FW-GS16-TM4

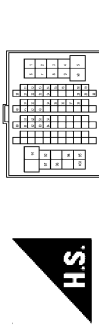

Terminal No.	Color Of Wire	Signal Name (Specification)
1	W	-
2	L/W	-
3	R/B	-
4	L	-
5	Y	-

6	SB	-
7	W/G	-
8	P/B	-
9	W/B	-
10	G	-
11	L	-
12	P	-
13	P/B	-
14	BR	-
15	O/L	-
16	SB	-
18	BR	-
19	Y/G	-
20	BRY	-
21	V	-
22	L	-
23	V	-
24	L/W	-
28	O	-
29	R/W	-
30	O/L	-
31	Y	-
32	GR/R	-
34	Y	-
35	R	-
36	B/O	-
37	G/Y	-
38	G	-
40	SB	-
41	W/R	-
42	R	-
43	V	-
51	L/O	-
52	BR/W	-
53	BRY	-
54	GR/L	-
60	W	-
61	B	-
62	G	-
63	R	-
64	SHIELD	-
91	BR	-
92	L/W	-
94	Y/B	-
95	L/R	-
97	R	-
98	O/L	-
100	W/B	-

A
B
C
D
E
F
G
H
I
J
K
L
M
N
O
P



POWER WINDOW SYSTEM

< WIRING DIAGRAM >

POWER WINDOW SYSTEM

Connector No.	M111
Connector Name	WIPE TO WIRE
Connector Type	TH89FW-CS16-TM4



Terminal No.	Color Of Wire	Signal Name [Specification]
1	R/B	-
2	G	-
3	W/R	-
5	W/B	-
6	L/Y	-
7	B	-
8	G/R	-
9	GR/R	-
11	W	-
12	V	-
13	Y	-
16	L/O	-
17	GR/L	-
18	RG	-
19	L/Y	-
20	G/Y	-
21	R	-
22	GR	-
27	L/O	-
29	SB	-
30	R/L	-
31	Y/L	-
32	W/R	-
33	W/G	-
34	L/R	-
36	G	-
37	V	-
38	SHIELD	-
39	P/B	-
40	W/R	-
41	R	-
42	L/W	-
43	B/W	-
44	B	-
45	B	-
46	SHIELD	-

47	R	-
48	W	-
49	SHIELD	-
50	V	-
51	O/L	-
52	L/R	-
53	SB	-
54	V/W	-
59	L	-
60	GR	-
61	P/L	-
62	B/SB	-
63	R/Y	-
64	BR	-
70	O	-
71	W	-
72	SHIELD	-
73	B	-
74	R	-
75	G	-
76	Y	-
77	SB	-
78	LG	-
79	R/B	-
90	W/B	-
93	Y	-
94	L	-
95	L/R	-
96	R	-
97	W	-
98	V	-
99	L/W	-
100	W	-

JRKWC5525GB

DIAGNOSIS AND REPAIR WORKFLOW

< BASIC INSPECTION >

BASIC INSPECTION

DIAGNOSIS AND REPAIR WORKFLOW

Work Flow

INFOID:000000009009736

DETAILED FLOW

1.OBTAIN INFORMATION ABOUT SYMPTOM

Interview the customer to obtain as much malfunction information (conditions and environment when the malfunction occurred) as possible when the customer brings the vehicle in.

>> GO TO 2.

2.REPRODUCE THE MALFUNCTION INFORMATION

Check the malfunction on the vehicle that the customer describes.
Inspect the relation of the symptoms and the condition when the symptoms occur.

>> GO TO 3.

3.IDENTIFY THE MALFUNCTIONING SYSTEM WITH "SYMPTOM DIAGNOSIS"

Use "Symptom diagnosis" from the symptom inspection result in step 2. Then identify where to start the diagnosis based on possible causes and symptoms.

>> GO TO 4.

4.IDENTIFY MALFUNCTIONING PARTS WITH "COMPONENT DIAGNOSIS"

Perform the diagnosis with "Component diagnosis" of the applicable system.

>> GO TO 5.

5.REPAIR OR REPLACE THE MALFUNCTIONING PARTS

Repair or replace the specified malfunctioning parts.

>> GO TO 6.

6.FINAL CHECK

Check that malfunctions are not reproduced when obtaining the malfunction information from the customer, referring to the symptom inspection result in step 2.

Is the malfunctioning part repaired or replaced?

YES >> Trouble diagnosis is completed.

NO >> GO TO 3.

A
B
C
D
E
F
G
H
I
J
PWC
L
M
N
O
P

ADDITIONAL SERVICE WHEN REMOVING BATTERY NEGATIVE TERMINAL

< BASIC INSPECTION >

ADDITIONAL SERVICE WHEN REMOVING BATTERY NEGATIVE TERMINAL

Description

INFOID:000000009009737

When the battery negative terminal is disconnected, the initialization is necessary for normal operation of power window system.

CAUTION:

The following specified operations can not be performed under the non-initialized condition.

- Auto-up operation
- Anti-pinch function

Work Procedure

INFOID:000000009009738

1.SYSTEM INITIALIZATION

Perform system initialization. Refer to [PWC-34. "Work Procedure"](#).

>> GO TO 2.

2.CHECK ANTI-PINCH FUNCTION

Check anti-pinch function. Refer to [PWC-35. "Work Procedure"](#).

>> END

ADDITIONAL SERVICE WHEN REPLACING CONTROL UNIT

< BASIC INSPECTION >

ADDITIONAL SERVICE WHEN REPLACING CONTROL UNIT

Description

INFOID:000000009009739

When the battery negative terminal is disconnected, the initialization is necessary for normal operation of power window system.

CAUTION:

The following specified operations can not be performed under the non-initialized condition.

- Auto-up operation
- Anti-pinch function

Work Procedure

INFOID:000000009009740

1.SYSTEM INITIALIZATION

Perform system initialization. Refer to [PWC-34. "Work Procedure"](#).

>> GO TO 2.

2.CHECK ANTI-PINCH FUNCTION

Check anti-pinch function. Refer to [PWC-35. "Work Procedure"](#).

>> END

A
B
C
D
E
F
G
H
I
J
L
M
N
O
P

PWC

SYSTEM INITIALIZATION

< BASIC INSPECTION >

SYSTEM INITIALIZATION

Description

INFOID:000000009009741

If any of the following operations are performed, the initialization is necessary for normal operation of power window system.

- When control unit replaced.
- Electric power supply to power window switch or motor is interrupted by blown fuse or disconnection and connection of the negative terminal of battery, etc.
- Removal and installation of regulator assembly.
- Power supply to the power window main switch or power window motor is cut off by the removal of battery terminal or if the battery fuse is blown.
- Disconnection and connection of power window main switch harness connector.
- Removal and installation of motor from regulator assembly.
- Operation of regulator assembly as an independent unit.
- Removal and installation of door glass.
- Removal and installation of door glass run.

The following specified operations can not be performed under the non-initialized condition.

- Auto-up operation
- Anti-pinch function

Work Procedure

INFOID:000000009009742

1. STEP 1

-
1. Turn ignition switch ON.
 2. Operate power window switch to fully open the window. (This operation is unnecessary if the window is already fully open)
 3. Continue pulling the power window switch UP (AUTO-UP operation). Even after glass stops at fully closed position, keep pulling the switch for 2 seconds or more.
 4. Check that AUTO-UP function operates normally.

>> GO TO 2.

2. STEP 2

Check anti-pinch function. Refer to [PWC-35. "Work Procedure"](#).

>> END

CHECK ANTI-PINCH FUNCTION

< BASIC INSPECTION >

CHECK ANTI-PINCH FUNCTION

Description

INFOID:000000009009743

If any of the following operations are performed, the initialization is necessary for normal operation of power window system.

- When control unit replaced.
- Electric power supply to power window switch or motor is interrupted by blown fuse or disconnection and connection of the negative terminal of battery, etc.
- Removal and installation of regulator assembly.
- Power supply to the power window main switch or power window motor is cut off by the removal of battery terminal or if the battery fuse is blown.
- Disconnection and connection of power window main switch harness connector.
- Removal and installation of motor from regulator assembly.
- Operation of regulator assembly as an independent unit.
- Removal and installation of door glass.
- Removal and installation of door glass run.

The following specified operations can not be performed under the non-initialized condition.

- Auto-up operation
- Anti-pinch function

Work Procedure

INFOID:000000009009744

1. CHECK ANTI-PINCH FUNCTION

- Fully open the door window.
- Place a piece of wood near fully closed position.
- Close door glass completely with AUTO-UP.
- Check the following conditions
 - Check that glass lowers for approximately 150 mm (5.9 in) without pinching piece of wood and stops.
 - Check that glass does not rise not when operating the power window main switch while lowering.

CAUTION:

- **Perform initial setting when AUTO-UP operation or anti-pinch function does not operate normally.**
- **Check that AUTO-UP operates before inspection when system initialization is performed.**
- **Do not check with hands and other body parts because they may be pinched. Do not get pinched.**

>> END

A
B
C
D
E
F
G
H
I
J
L
M
N
O
P

PWC

POWER SUPPLY AND GROUND CIRCUIT

< DTC/CIRCUIT DIAGNOSIS >

DTC/CIRCUIT DIAGNOSIS

POWER SUPPLY AND GROUND CIRCUIT

POWER WINDOW MAIN SWITCH

POWER WINDOW MAIN SWITCH : Diagnosis Procedure

INFOID:000000009009745

1. CHECK POWER SUPPLY

1. Turn ignition switch OFF.
2. Disconnect power window main switch connectors.
3. Turn ignition switch ON.
4. Check voltage between power window main switch harness connector and ground.

(+)		(-)	Voltage (V) (Approx.)
Power window main switch			
Connector	Terminal	Ground	12
D5	9		
	4		

Is the inspection result normal?

YES >> GO TO 3.

NO >> GO TO 2.

2. CHECK POWER SUPPLY CIRCUIT

1. Turn ignition switch OFF.
2. Disconnect BCM connector.
3. Check continuity between BCM harness connector and power window main switch harness connector.

BCM		Power window main switch		Continuity
Connector	Terminal	Connector	Terminal	
M70	68	D5	9	Existed
	69		4	

4. Check continuity between BCM harness connector and ground.

BCM		Ground	Continuity
Connector	Terminal		
M70	68		Not existed
	69		

Is the inspection result normal?

YES >> Replace BCM. Refer to [BCS-95. "Removal and Installation"](#).

NO >> Repair or replace harness.

3. CHECK GROUND CIRCUIT

1. Turn ignition switch OFF.
2. Check continuity between power window main switch harness connector and ground.

Power window main switch		Ground	Continuity
Connector	Terminal		
D5	7		Existed

Is the inspection result normal?

YES >> GO TO 4.

NO >> Repair or replace harness.

4. CHECK INTERMITTENT INCIDENT

POWER SUPPLY AND GROUND CIRCUIT

< DTC/CIRCUIT DIAGNOSIS >

Refer to [GI-43. "Intermittent Incident"](#).

>> INSPECTION END

FRONT POWER WINDOW SWITCH (PASSENGER SIDE)

FRONT POWER WINDOW SWITCH (PASSENGER SIDE) : Diagnosis Procedure

INFOID:000000009009746

1. CHECK POWER SUPPLY

1. Turn ignition switch OFF.
2. Disconnect front power window switch (passenger side) connector.
3. Check voltage between front power window switch (passenger side) harness connector and ground.

(+)		(-)	Voltage (V) (Approx.)
Front power window switch (passenger side)			
Connector	Terminal	Ground	12
D25	10		

Is the inspection result normal?

YES >> GO TO 3.

NO >> GO TO 2.

2. CHECK POWER SUPPLY CIRCUIT

1. Disconnect BCM connector.
2. Check continuity between BCM harness connector and front power window switch (passenger side) harness connector.

BCM		Front power window switch (passenger side)		Continuity
Connector	Terminal	Connector	Terminal	
M70	69	D25	10	Existed

3. Check continuity between BCM harness connector and ground.

BCM		Ground	Continuity
Connector	Terminal		
M70	69		Not existed

Is the inspection result normal?

YES >> Replace BCM. Refer to [BCS-95. "Removal and Installation"](#).

NO >> Repair or replace harness.

3. CHECK GROUND CIRCUIT

Check continuity between front power window switch (passenger side) harness connector and ground.

Front power window switch (passenger side)		Ground	Continuity
Connector	Terminal		
D25	11		Existed

Is the inspection result normal?

YES >> GO TO 4.

NO >> Repair or replace harness.

4. CHECK INTERMITTENT INCIDENT

Refer to [GI-43. "Intermittent Incident"](#).

A
B
C
D
E
F
G
H
I
J
L
M
N
O
P

PWC

POWER SUPPLY AND GROUND CIRCUIT

< DTC/CIRCUIT DIAGNOSIS >

>> INSPECTION END

REAR POWER WINDOW SWITCH

REAR POWER WINDOW SWITCH : Diagnosis Procedure

INFOID:000000009009747

1. CHECK POWER SUPPLY

1. Turn ignition switch OFF.
2. Disconnect rear power window switch LH connector and rear power window switch RH connector.
3. Turn ignition switch ON.
4. Check voltage between rear power window switch harness connector and ground.

(+)		Terminal	(-)	Voltage (V) (Approx.)
Rear power window switch				
Connector		Terminal	Ground	12
LH	D63	10		
RH	D43			

Is the inspection result normal?

YES >> GO TO 3.

NO >> GO TO 2.

2. CHECK POWER SUPPLY CIRCUIT

1. Turn ignition switch OFF.
2. Disconnect BCM connector.
3. Check continuity between BCM harness connector and rear power window switch harness connector.

BCM		Rear power window switch		Continuity
Connector	Terminal	Connector	Terminal	
M70	69	LH	D63	Existed
		RH	D43	

4. Check continuity between BCM harness connector and ground.

BCM		Ground	Continuity
Connector	Terminal		
M70	69		Not existed

Is the inspection result normal?

YES >> Replace BCM. Refer to [BCS-95. "Removal and Installation"](#).

NO >> Repair or replace harness.

3. CHECK GROUND CIRCUIT

1. Turn ignition switch OFF.
2. Check continuity between rear power window switch harness connector and ground.

Rear power window switch		Terminal	Ground	Continuity
Connector				
LH	D63	11	Ground	Existed
RH	D43			

Is the inspection result normal?

YES >> GO TO 4.

NO >> Repair or replace harness.

4. CHECK INTERMITTENT INCIDENT

Refer to [GI-43. "Intermittent Incident"](#).

POWER SUPPLY AND GROUND CIRCUIT

< DTC/CIRCUIT DIAGNOSIS >

>> INSPECTION END

A

B

C

D

E

F

G

H

I

J

PWC

L

M

N

O

P

POWER WINDOW MOTOR

< DTC/CIRCUIT DIAGNOSIS >

POWER WINDOW MOTOR

DRIVER SIDE

DRIVER SIDE : Component Function Check

INFOID:000000009009748

1.CHECK POWER WINDOW MOTOR CIRCUIT

Check front power window motor (driver side) operation with power window main switch.

Is the inspection result normal?

YES >> Front power window motor (driver side) is OK.

NO >> Refer to [PWC-40. "DRIVER SIDE : Diagnosis Procedure"](#).

DRIVER SIDE : Diagnosis Procedure

INFOID:000000009009749

1.CHECK FRONT POWER WINDOW MOTOR INPUT SIGNAL

1. Turn ignition switch OFF.
2. Disconnect front power window motor (driver side) connector.
3. Turn ignition switch ON.
4. Check voltage between front power window motor (driver side) harness connector and ground.

(+)		(-)	Condition	Voltage (V) (Approx.)	
Front power window motor (driver side)					
Connector	Terminal				
D7	3	Ground	Power window main switch	UP	12
				DOWN	0
	1			UP	0
				DOWN	12

Is the inspection result normal?

YES >> Replace front power window motor (driver side). Refer to [GW-22. "Removal and Installation"](#).

NO >> GO TO 2.

2.CHECK POWER WINDOW MOTOR CIRCUIT

1. Turn ignition switch OFF.
2. Disconnect power window main switch connector.
3. Check continuity between power window main switch harness connector and front power window motor (driver side) harness connector.

Power window main switch		Front power window motor (driver side)		Continuity
Connector	Terminal	Connector	Terminal	
D5	6	D7	3	Existed
	5		1	

4. Check continuity between power window main switch harness connector and ground.

Power window main switch		Ground	Continuity
Connector	Terminal		
D5	6		Not existed
	5		

Is the inspection result normal?

YES >> Replace power window main switch. Refer to [PWC-75. "Removal and Installation"](#).

NO >> Repair or replace harness.

PASSENGER SIDE

POWER WINDOW MOTOR

< DTC/CIRCUIT DIAGNOSIS >

PASSENGER SIDE : Component Function Check

INFOID:000000009009750

1. CHECK POWER WINDOW MOTOR CIRCUIT

Check front power window motor (passenger side) operation with power window main switch or front power window switch (passenger side).

Is the inspection result normal?

- YES >> Front power window motor (passenger side) is OK.
- NO >> Refer to [PWC-41, "PASSENGER SIDE : Diagnosis Procedure"](#).

PASSENGER SIDE : Diagnosis Procedure

INFOID:000000009009751

1. CHECK FRONT POWER WINDOW MOTOR INPUT SIGNAL

1. Turn ignition switch OFF.
2. Disconnect front power window motor (passenger side) connector.
3. Turn ignition switch ON.
4. Check voltage between front power window motor (passenger side) harness connector and ground.

(+)		(-)	Condition	Voltage (V) (Approx.)
Connector	Terminal			
D27	3	Ground	Front power window switch (passenger side) UP	12
			DOWN	0
	1		UP	0
			DOWN	12

Is the inspection result normal?

- YES >> Replace front power window motor (passenger side). Refer to [GW-22, "Removal and Installation"](#).
- NO >> GO TO 2.

2. CHECK POWER WINDOW MOTOR CIRCUIT

1. Turn ignition switch OFF.
2. Disconnect front power window switch (passenger side) connector.
3. Check continuity between front power window switch (passenger side) harness connector and front power window motor (passenger side) harness connector.

Front power window switch (passenger side)		Front power window motor (passenger side)		Continuity
Connector	Terminal	Connector	Terminal	
D25	8	D27	3	Existed
	9		1	

4. Check continuity between front power window switch (passenger side) connector and ground.

Front power window switch (passenger side)		Ground	Continuity
Connector	Terminal		
D25	8		Not existed
	9		

Is the inspection result normal?

- YES >> Replace front power window switch (passenger side). Refer to [PWC-75, "Removal and Installation"](#).
- NO >> Repair or replace harness.

REAR LH

A
B
C
D
E
F
G
H
I
J
L
M
N
O
P

PWC

POWER WINDOW MOTOR

< DTC/CIRCUIT DIAGNOSIS >

REAR LH : Component Function Check

INFOID:000000009009752

1. CHECK POWER WINDOW MOTOR CIRCUIT

Check rear power window motor LH operation with power window main switch or rear power window switch LH.

Is the inspection result normal?

- YES >> Rear power window motor LH is OK.
- NO >> Refer to [PWC-42, "REAR LH : Diagnosis Procedure"](#).

REAR LH : Diagnosis Procedure

INFOID:000000009009753

1. CHECK REAR POWER WINDOW MOTOR INPUT SIGNAL

1. Turn ignition switch OFF.
2. Disconnect rear power window motor LH connector.
3. Turn ignition switch ON.
4. Check voltage between rear power window motor LH harness connector and ground.

(+)		(-)	Condition	Voltage (V) (Approx.)	
Connector	Terminal				
D67	1	Ground	Rear power window switch LH	UP	12
			DOWN	0	
	3		UP	0	
			DOWN	12	

Is the inspection result normal?

- YES >> Replace rear power window motor LH. Refer to [GW-27, "Removal and Installation"](#).
- NO >> GO TO 2.

2. CHECK POWER WINDOW MOTOR CIRCUIT

1. Turn ignition switch OFF.
2. Disconnect rear power window switch LH connector.
3. Check continuity between rear power window switch LH harness connector and rear power window motor LH harness connector.

Rear power window switch LH		Rear power window motor LH		Continuity
Connector	Terminal	Connector	Terminal	
D63	8	D67	1	Existed
	9		3	

4. Check continuity between rear power window switch LH harness connector and ground.

Rear power window switch LH		Ground	Continuity
Connector	Terminal		
D63	8		Not existed
	9		

Is the inspection result normal?

- YES >> Replace rear power window switch LH. Refer to [PWC-75, "Removal and Installation"](#).
- NO >> Repair or replace harness.

REAR RH

REAR RH : Component Function Check

INFOID:000000009009754

1. CHECK POWER WINDOW MOTOR CIRCUIT

POWER WINDOW MOTOR

< DTC/CIRCUIT DIAGNOSIS >

Check rear power window motor RH operation with power window main switch or rear power window switch RH.

Is the inspection result normal?

- YES >> Rear power window motor RH is OK.
- NO >> Refer to [PWC-43, "REAR RH : Diagnosis Procedure"](#).

REAR RH : Diagnosis Procedure

INFOID:000000009009755

1. CHECK REAR POWER WINDOW MOTOR INPUT SIGNAL

1. Turn ignition switch OFF.
2. Disconnect rear power window motor RH connector.
3. Turn ignition switch ON.
4. Check voltage between rear power window motor RH harness connector and ground.

(+)		(-)	Condition	Voltage (V) (Approx.)	
Connector	Terminal				
D47	1	Ground	Rear power window switch RH	UP	12
				DOWN	0
	3			UP	0
				DOWN	12

Is the inspection result normal?

- YES >> Replace rear power window motor RH. Refer to [GW-27, "Removal and Installation"](#).
- NO >> GO TO 2.

2. CHECK POWER WINDOW MOTOR CIRCUIT

1. Turn ignition switch OFF.
2. Disconnect rear power window switch RH connector.
3. Check continuity between rear power window switch RH harness connector and rear power window motor RH harness connector.

Rear power window switch RH		Rear power window motor RH		Continuity
Connector	Terminal	Connector	Terminal	
D43	8	D47	1	Existed
	9		3	

4. Check continuity between rear power window switch RH harness connector and ground.

Rear power window switch RH		Ground	Continuity
Connector	Terminal		
D43	8		Not existed
	9		

Is the inspection result normal?

- YES >> Replace rear power window switch RH. Refer to [PWC-75, "Removal and Installation"](#).
- NO >> Repair or replace harness.

ENCODER

< DTC/CIRCUIT DIAGNOSIS >

ENCODER DRIVER SIDE

DRIVER SIDE : Component Function Check

INFOID:000000009009756

1.CHECK ENCODER

Check that driver side door glass performs AUTO open/close operation normally by power window main switch.

Is the inspection result normal?

- YES >> Encoder is OK.
NO >> Refer to [PWC-44, "DRIVER SIDE : Diagnosis Procedure"](#).

DRIVER SIDE : Diagnosis Procedure

INFOID:000000009009757

1.CHECK ENCODER SIGNAL

- Turn ignition switch ON.
- Check signal between power window main switch harness connector and ground with oscilloscope.

Signal name	(+)		(-)	Signal (Reference value)
	Power window main switch			
	Connector	Terminal		
Encoder signal 1	D5	11	Ground	Refer to following signal
Encoder signal 2		12		

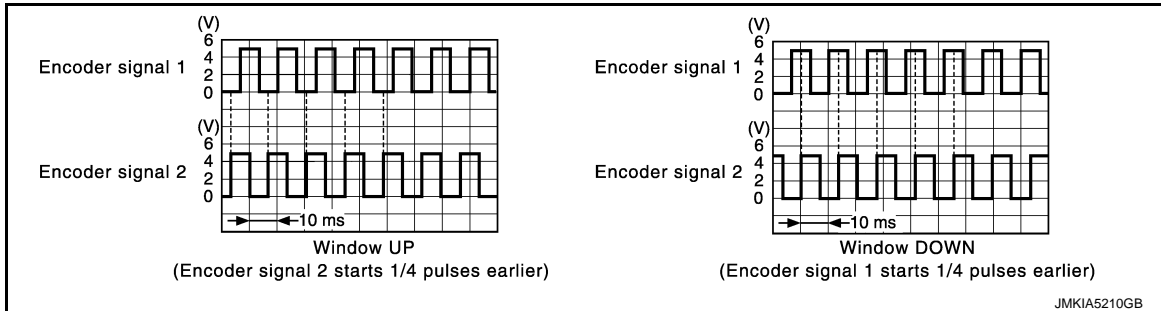

Is the inspection result normal?

- YES >> Replace power window main switch. Refer to [PWC-75, "Removal and Installation"](#).
NO >> GO TO 2.

2.CHECK ENCODER SIGNAL CIRCUIT

- Turn ignition switch OFF.
- Disconnect power window main switch connector and front power window motor (driver side) connector.
- Check continuity between power window main switch harness connector and front power window motor (driver side) harness connector.

Power window main switch		Front power window motor (driver side)		Continuity
Connector	Terminal	Connector	Terminal	
D5	11	D7	5	Existed
	12		6	

- Check continuity between power window main switch harness connector and ground.

ENCODER

< DTC/CIRCUIT DIAGNOSIS >

Power window main switch		Ground	Continuity
Connector	Terminal		
D5	11		Not existed
	12		

Is the inspection result normal?

YES >> GO TO 3.

NO >> Repair or replace harness.

3.CHECK ENCORDER POWER SUPPLY

1. Connect power window main switch connector.
2. Turn ignition switch ON.
3. Check voltage between front power window motor (driver side) harness connector and ground.

(+)		(-)	Voltage (V) (Approx.)
Front power window motor (driver side)			
Connector	Terminal		
D7	2	Ground	12

Is the inspection result normal?

YES >> GO TO 5.

NO >> GO TO 4.

4.CHECK ENCORDER POWER SUPPLY CIRCUIT

1. Turn ignition switch OFF.
2. Disconnect power window main switch connector.
3. Check continuity between power window main switch harness connector and front power window motor (driver side) harness connector.

Power window main switch		Front power window motor (driver side)		Continuity
Connector	Terminal	Connector	Terminal	
D5	3	D7	2	Existed

4. Check continuity between power window main switch harness connector and ground.

Power window main switch		Ground	Continuity
Connector	Terminal		
D5	3		Not existed

Is the inspection result normal?

YES >> Replace power window main switch. Refer to [PWC-75. "Removal and Installation"](#).

NO >> Repair or replace harness.

5.CHECK GROUND CIRCUIT 1

1. Turn ignition switch OFF.
2. Check continuity between front power window motor (driver side) harness connector and ground.

Front power window motor (driver side)		Ground	Continuity
Connector	Terminal		
D7	4		Existed

Is the inspection result normal?

YES >> Replace front power window motor (driver side). Refer to [GW-22. "Removal and Installation"](#).

NO >> GO TO 6.

6.CHECK GROUND CIRCUIT 2

1. Disconnect power window main switch connector.

A
B
C
D
E
F
G
H
I
J
L
M
N
O
P

PWC

ENCODER

< DTC/CIRCUIT DIAGNOSIS >

- Check continuity between power window main switch harness connector and front power window motor (driver side) harness connector.

Power window main switch		Front power window motor (driver side)		Continuity
Connector	Terminal	Connector	Terminal	
D5	10	D7	4	Existed

Is the inspection result normal?

YES >> GO TO 7.

NO >> Repair or replace harness.

7.CHECK GROUND CIRCUIT 3

Check continuity between power window main switch terminals.

Power window main switch			Continuity
Connector	Terminal		
D5	7	10	Existed

Is the inspection result normal?

YES >> GO TO 8.

NO >> Replace power window main switch. Refer to [PWC-75, "Removal and Installation"](#).

8.CHECK INTERMITTENT INCIDENT

Refer to [GI-43, "Intermittent Incident"](#).

>> INSPECTION END

PASSENGER SIDE

PASSENGER SIDE : Component Function Check

INFOID:00000000909758

1.CHECK ENCODER

Check that passenger side door glass performs AUTO open/close operation normally by power window main switch or front power window switch (passenger side).

Is the inspection result normal?

YES >> Encoder is OK.

NO >> Refer to [PWC-46, "PASSENGER SIDE : Diagnosis Procedure"](#).

PASSENGER SIDE : Diagnosis Procedure

INFOID:00000000909759

1.CHECK ENCODER SIGNAL

- Turn ignition switch ON.
- Check signal between front power window switch (passenger side) harness connector and ground with oscilloscope.

Signal name	(+)		(-)	Signal (Reference value)
	Front power window switch (passenger side)			
	Connector	Terminal		
Encoder signal 1	D25	12	Ground	Refer to following signal
Encoder signal 2		15		

ENCODER

< DTC/CIRCUIT DIAGNOSIS >

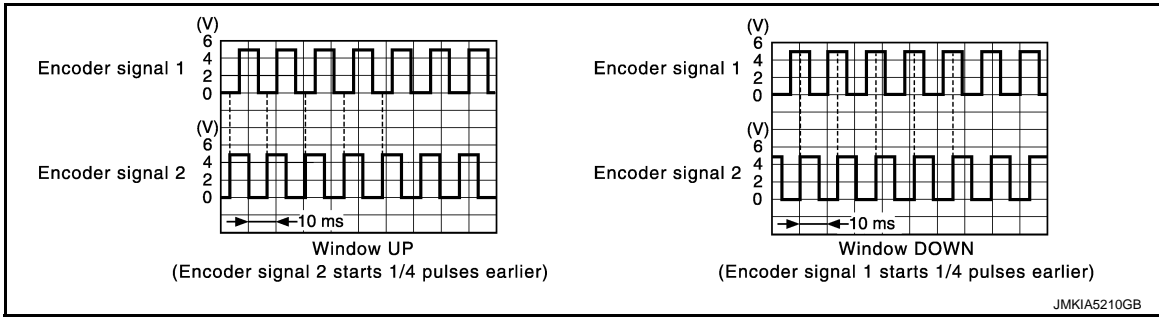

Is the inspection result normal?

YES >> Replace front power window switch (passenger side). Refer to [PWC-75, "Removal and Installation"](#).

NO >> GO TO 2.

2.CHECK ENCODER SIGNAL CIRCUIT

1. Turn ignition switch OFF.
2. Disconnect front power window switch (passenger side) connector and front power window motor (passenger side) connector.
3. Check continuity between front power window switch (passenger side) harness connector and front power window motor (passenger side) harness connector.

Front power window switch (passenger side)		Front power window motor (passenger side)		Continuity
Connector	Terminal	Connector	Terminal	
D25	12	D27	5	Existed
	15		6	

4. Check continuity between front power window switch (passenger side) harness connector and ground.

Front power window switch (passenger side)		Ground	Continuity
Connector	Terminal		
D25	12		Not existed
	15		

Is the inspection result normal?

YES >> GO TO 3.

NO >> Repair or replace harness.

3.CHECK ENCODER POWER SUPPLY

1. Connect front power window switch (passenger side) connector.
2. Turn ignition switch ON.
3. Check voltage between front power window motor (passenger side) harness connector and ground.

(+)		(-)	Voltage (V) (Approx.)
Front power window motor (passenger side)			
Connector	Terminal		
D27	2	Ground	12

Is the inspection result normal?

YES >> GO TO 5.

NO >> GO TO 4.

4.CHECK ENCODER POWER SUPPLY CIRCUIT

1. Turn ignition switch OFF.
2. Disconnect front power window switch (passenger side) connector.
3. Check continuity between front power window switch (passenger side) harness connector and front power window motor (passenger side) harness connector.

ENCODER

< DTC/CIRCUIT DIAGNOSIS >

Front power window switch (passenger side)		Front power window motor (passenger side)		Continuity
Connector	Terminal	Connector	Terminal	
D25	4	D27	2	Existed

4. Check continuity between front power window switch (passenger side) harness connector and ground.

Front power window switch (passenger side)		Ground	Continuity
Connector	Terminal		
D25	4		Not existed

Is the inspection result normal?

YES >> Replace front power window switch (passenger side). Refer to [PWC-75, "Removal and Installation"](#).

NO >> Repair or replace harness.

5.CHECK GROUND CIRCUIT 1

1. Turn ignition switch OFF.
2. Check continuity between front power window motor (passenger side) harness connector and ground.

Front power window motor (passenger side)		Ground	Continuity
Connector	Terminal		
D27	4		Existed

Is the inspection result normal?

YES >> Replace front power window motor (passenger side). Refer to [GW-22, "Removal and Installation"](#).

NO >> GO TO 6.

6.CHECK GROUND CIRCUIT 2

1. Disconnect front power window switch (passenger side) connector.
2. Check continuity between front power window switch (passenger side) harness connector and front power window motor (passenger side) harness connector.

Front power window switch (passenger side)		Front power window motor (passenger side)		Continuity
Connector	Terminal	Connector	Terminal	
D25	3	D27	4	Existed

Is the inspection result normal?

YES >> GO TO 7.

NO >> Repair or replace harness.

7.CHECK GROUND CIRCUIT 3

Check continuity between front power window switch (passenger side) terminals.

Front power window switch (passenger side)			Continuity
Connector	Terminal		
D25	3	11	Existed

Is the inspection result normal?

YES >> GO TO 8.

NO >> Replace front power window switch (passenger side). Refer to [PWC-75, "Removal and Installation"](#).

8.CHECK INTERMITTENT INCIDENT

Refer to [GI-43, "Intermittent Incident"](#).

>> INSPECTION END

REAR LH

ENCODER

< DTC/CIRCUIT DIAGNOSIS >

REAR LH : Component Function Check

INFOID:000000009009760

1.CHECK ENCODER OPERATION

Check that rear door LH glass performs AUTO open/close operation normally by power window main switch or rear power window switch LH.

Is the inspection result normal?

- YES >> Encoder operation is OK.
- NO >> Refer to [PWC-49, "REAR LH : Diagnosis Procedure"](#).

REAR LH : Diagnosis Procedure

INFOID:000000009009761

1.CHECK ENCODER SIGNAL

1. Turn ignition switch ON.
2. Check signal between rear power window switch LH harness connector and ground with oscilloscope.

Signal name	(+)		(-)	Signal (Reference value)
	Rear power window switch LH			
	Connector	Terminal		
Encoder signal 1	D63	12	Ground	Refer to following signal
Encoder signal 2		15		

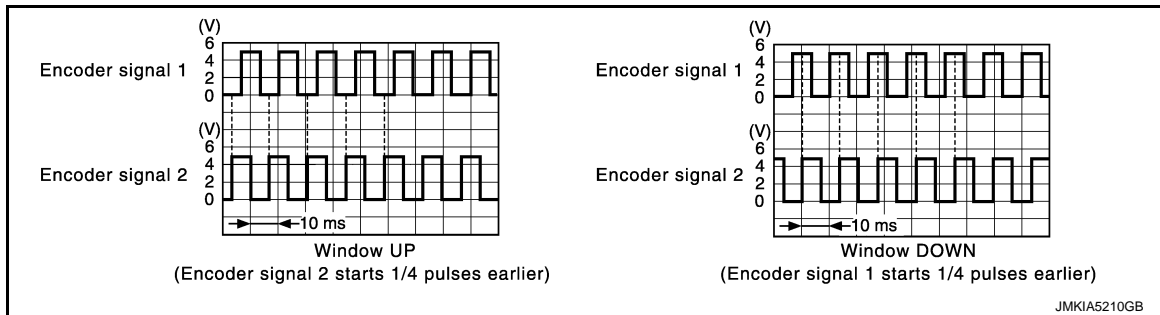

Is the inspection result normal?

- YES >> Replace rear power window switch LH. Refer to [PWC-75, "Removal and Installation"](#).
- NO >> GO TO 2.

2.CHECK ENCODER SIGNAL CIRCUIT

1. Turn ignition switch OFF.
2. Disconnect rear power window switch LH connector and rear power window motor LH connector.
3. Check continuity between rear power window switch LH harness connector and rear power window motor LH harness connector.

Rear power window switch LH		Rear power window motor LH		Continuity
Connector	Terminal	Connector	Terminal	
D63	12	D67	5	Existed
	15		6	

4. Check continuity rear power window switch LH harness connector and ground.

Rear power window switch LH		Ground	Continuity
Connector	Terminal		
D63	12		Ground
	15		

Is the inspection result normal?

- YES >> GO TO 3.
- NO >> Repair or replace harness.

ENCODER

< DTC/CIRCUIT DIAGNOSIS >

3.CHECK ENCODER POWER SUPPLY

1. Connect rear power window switch LH connector.
2. Turn ignition switch ON.
3. Check voltage between rear power window motor LH harness connector and ground.

(+)		(-)	Voltage (V) (Approx.)
Rear power window motor LH			
Connector	Terminal	Ground	12
D67	2		

Is the inspection result normal?

- YES >> GO TO 5.
NO >> GO TO 4.

4.CHECK ENCODER POWER SUPPLY CIRCUIT

1. Turn ignition switch OFF.
2. Disconnect rear power window switch LH connector.
3. Check continuity between rear power window switch LH harness connector and rear power window motor LH harness connector.

Rear power window switch LH		Rear power window motor LH		Continuity
Connector	Terminal	Connector	Terminal	
D63	4	D67	2	Existed

4. Check continuity between rear power window switch LH harness connector and ground.

Rear power window switch LH		Ground	Continuity
Connector	Terminal		
D63	4	Not existed	

Is the inspection result normal?

- YES >> Replace rear power window switch LH. Refer to [PWC-75, "Removal and Installation"](#).
NO >> Repair or replace harness.

5.CHECK GROUND CIRCUIT 1

1. Turn ignition switch OFF.
2. Check continuity between rear power window motor LH harness connector and ground.

Rear power window motor LH		Ground	Continuity
Connector	Terminal		
D67	4	Existed	

Is the inspection result normal?

- YES >> Replace rear power window motor LH. Refer to [GW-27, "Removal and Installation"](#).
NO >> GO TO 6.

6.CHECK GROUND CIRCUIT 2

1. Disconnect rear power window switch LH harness connector.
2. Check continuity between rear power window switch LH harness connector and rear power window motor LH harness connector.

Rear power window switch LH		Rear power window motor LH		Continuity
Connector	Terminal	Connector	Terminal	
D63	3	D67	4	Existed

Is the inspection result normal?

- YES >> GO TO 7.
NO >> Repair or replace harness.

ENCODER

< DTC/CIRCUIT DIAGNOSIS >

7. CHECK GROUND CIRCUIT 3

Check continuity between front power window switch (passenger side) terminals.

Rear power window switch LH			Continuity
Connector	Terminal		
D63	3	11	Existed

Is the inspection result normal?

YES >> GO TO 8.

NO >> Replace rear power window switch LH. Refer to [PWC-75. "Removal and Installation"](#).

8. CHECK INTERMITTENT INCIDENT

Refer to [GI-43. "Intermittent Incident"](#).

>> INSPECTION END

REAR RH

REAR RH : Component Function Check

INFOID:000000009009762

1. CHECK ENCODER OPERATION

Check that rear door RH glass performs AUTO open/close operation normally by power window main switch or rear power window switch RH.

Is the inspection result normal?

YES >> Encoder operation is OK.

NO >> Refer to [PWC-51. "REAR RH : Diagnosis Procedure"](#).

REAR RH : Diagnosis Procedure

INFOID:000000009009763

1. CHECK ENCODER SIGNAL

1. Turn ignition switch ON.
2. Check signal between rear power window switch RH harness connector and ground with oscilloscope.

Signal name	(+)		(-)	Signal (Reference value)
	Rear power window switch RH			
	Connector	Terminal		
Encoder signal 1	D43	12	Ground	Refer to following signal
Encoder signal 2		15		

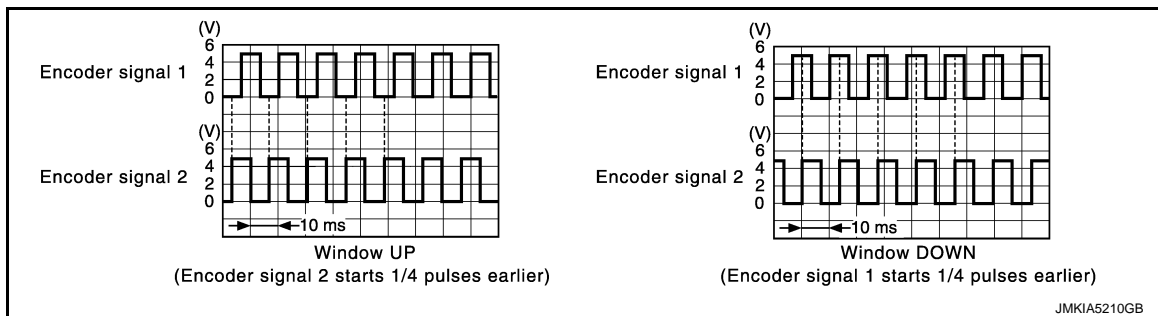

Is the inspection result normal?

YES >> Replace rear power window switch RH. Refer to [PWC-75. "Removal and Installation"](#).

NO >> GO TO 2.

2. CHECK ENCODER SIGNAL CIRCUIT

1. Turn ignition switch OFF.
2. Disconnect rear power window switch RH connector and rear power window motor RH connector.

ENCODER

< DTC/CIRCUIT DIAGNOSIS >

3. Check continuity between rear power window switch RH harness connector and rear power window motor RH harness connector.

Rear power window switch RH		Rear power window motor RH		Continuity
Connector	Terminal	Connector	Terminal	
D43	12	D47	5	Existed
	15		6	

4. Check continuity rear power window switch RH harness connector and ground.

Rear power window switch RH		Ground	Continuity
Connector	Terminal		
D43	12		Not existed
	15		

Is the inspection result normal?

YES >> GO TO 3.

NO >> Repair or replace harness.

3.CHECK ENCODER POWER SUPPLY

1. Connect rear power window switch RH connector.
2. Turn ignition switch ON.
3. Check voltage between rear power window motor RH harness connector and ground.

(+)			Voltage (V) (Approx.)
Rear power window motor RH			
Connector	Terminal	(-)	
D47	2	Ground	12

Is the inspection result normal?

YES >> GO TO 5.

NO >> GO TO 4.

4.CHECK ENCODER POWER SUPPLY CIRCUIT

1. Turn ignition switch OFF.
2. Disconnect rear power window switch RH connector.
3. Check continuity between rear power window switch RH harness connector and rear power window motor RH harness connector.

Rear power window switch RH		Rear power window motor RH		Continuity
Connector	Terminal	Connector	Terminal	
D43	4	D47	2	Existed

4. Check continuity between rear power window switch RH harness connector and ground.

Rear power window switch RH		Ground	Continuity
Connector	Terminal		
D43	4		Not existed

Is the inspection result normal?

YES >> Replace rear power window switch RH. Refer to [PWC-75, "Removal and Installation"](#).

NO >> Repair or replace harness.

5.CHECK GROUND CIRCUIT 1

1. Turn ignition switch OFF.
2. Check continuity between rear power window motor RH harness connector and ground.

ENCODER

< DTC/CIRCUIT DIAGNOSIS >

Rear power window motor RH		Ground	Continuity
Connector	Terminal		Existed
D47	4		

Is the inspection result normal?

YES >> Replace rear power window motor RH. Refer to [GW-27, "Removal and Installation"](#).

NO >> GO TO 6.

6.CHECK GROUND CIRCUIT 2

1. Disconnect rear power window switch RH harness connector.
2. Check continuity between rear power window switch RH harness connector and rear power window motor RH harness connector.

Rear power window switch RH		Rear power window motor RH		Continuity
Connector	Terminal	Connector	Terminal	
D43	3	D47	4	Existed

Is the inspection result normal?

YES >> GO TO 7.

NO >> Repair or replace harness.

7.CHECK GROUND CIRCUIT 3

Check continuity between front power window switch (passenger side) terminals.

Rear power window switch RH			Continuity
Connector	Terminal		
D43	3	11	Existed

Is the inspection result normal?

YES >> GO TO 8.

NO >> Replace rear power window switch RH. Refer to [PWC-75, "Removal and Installation"](#).

8.CHECK INTERMITTENT INCIDENT

Refer to [GI-43, "Intermittent Incident"](#).

>> INSPECTION END

A
B
C
D
E
F
G
H
I
J
L
M
N
O
P

PWC

DOOR KEY CYLINDER SWITCH

< DTC/CIRCUIT DIAGNOSIS >

DOOR KEY CYLINDER SWITCH

Component Function Check

INFOID:000000009009764

1. CHECK DOOR KEY CYLINDER SWITCH INPUT SIGNAL

Check ("KEY CYL LK-SW", "KEY CYL UN-SW") in "DATA MONITOR" mode for "POWER DOOR LOCK SYSTEM" with CONSULT. Refer to [DLK-40, "DOOR LOCK : CONSULT Function \(BCM - DOOR LOCK\)"](#).

Monitor item	Condition
KEY CYL LK-SW	Lock : ON
	Neutral / Unlock : OFF
KEY CYL UN-SW	Unlock : ON
	Neutral / Lock : OFF

Is the inspection result normal?

- YES >> Door key cylinder switch is OK.
 NO >> Refer to [PWC-54, "Diagnosis Procedure"](#).

Diagnosis Procedure

INFOID:000000009009765

1. CHECK DOOR KEY CYLINDER SWITCH SIGNAL

- Turn ignition switch OFF.
- Disconnect front door lock assembly (driver side) (door key cylinder switch) connect.
- Turn ignition switch ON.
- Check voltage between front door lock assembly (driver side) (door key cylinder switch) harness connector and ground.

(+)		(-)	Voltage (V) (Approx.)
Front door lock assembly (driver side) (door key cylinder switch)			
Connector	Terminal	Ground	5
D9	5		
	6		

Is the inspection result normal?

- YES >> GO TO 3.
 NO >> GO TO 2.

2. CHECK DOOR KEY CYLINDER SWITCH CIRCUIT

- Turn ignition switch OFF.
- Disconnect power window main switch connector.
- Check continuity between power window main switch harness connector and front door lock assembly (driver side) (door key cylinder switch) harness connector.

Power window main switch		Front door lock assembly (driver side) (door key cylinder switch)		Continuity
Connector	Terminal	Connector	Terminal	
D5	15	D9	6	Existed
	16		5	

- Check continuity between power window main switch harness connector and ground.

DOOR KEY CYLINDER SWITCH

< DTC/CIRCUIT DIAGNOSIS >

Power window main switch		Ground	Continuity
Connector	Terminal		
D5	15		Not existed
	16		

Is the inspection result normal?

- YES >> Replace power window main switch. Refer to [PWC-75. "Removal and Installation"](#).
 NO >> Repair or replace harness.

3.CHECK DOOR KEY CYLINDER SWITCH GROUND CIRCUIT

Check continuity between front door lock assembly (driver side) (door key cylinder switch) harness connector and ground.

Front door lock assembly (driver side) (door key cylinder switch)		Ground	Continuity
Connector	Terminal		
D9	4		Existed

Is the inspection result normal?

- YES >> GO TO 4.
 NO >> Repair or replace harness.

4.CHECK DOOR KEY CYLINDER SWITCH

Check front door lock assembly (driver side) (door key cylinder switch).
 Refer to [PWC-55. "Component Inspection"](#).

Is the inspection result normal?

- YES >> GO TO 5.
 NO >> Replace front door lock assembly (driver side) (door key cylinder switch). Refer to [DLK-246. "DOOR LOCK : Removal and Installation"](#).

5.CHECK INTERMITTENT INCIDENT

Refer to [GI-43. "Intermittent Incident"](#).

>> INSPECTION END

Component Inspection

INFOID:000000009009766

COMPONENT INSPECTION

1.CHECK DOOR KEY CYLINDER SWITCH

- Turn ignition switch OFF.
- Disconnect front door lock assembly (driver side) (door key cylinder switch) connector.
- Check front door lock assembly (driver side) (door key cylinder switch).

Front door lock assembly (driver side) (door key cylinder switch)		Key position	Continuity
Terminal			
5	4	Unlock	Existed
		Neutral / Lock	Not existed
6		Lock	Existed
		Neutral / Unlock	Not existed

Is the inspection result normal?

- YES >> INSPECTION END
 NO >> Replace front door lock assembly (driver side) (door key cylinder switch). Refer to [DLK-246. "DOOR LOCK : Removal and Installation"](#).

POWER WINDOW SERIAL LINK

< DTC/CIRCUIT DIAGNOSIS >

POWER WINDOW SERIAL LINK

POWER WINDOW MAIN SWITCH

POWER WINDOW MAIN SWITCH : Component Function Check

INFOID:000000009009767

1. CHECK POWER WINDOW SWITCH OUTPUT SIGNAL

With CONSULT

Check ("CDL LOCK SW", "CDL UNLOCK SW") in "DATA MONITOR" mode for "POWER DOOR LOCK SYSTEM" with CONSULT. Refer to [DLK-40, "DOOR LOCK : CONSULT Function \(BCM - DOOR LOCK\)"](#).

Monitor item	Condition
CDL LOCK SW	LOCK : ON
	UNLOCK : OFF
CDL UNLOCK SW	LOCK : OFF
	UNLOCK : ON

Is the inspection result normal?

YES >> Power window serial link is OK.

NO >> Refer to [PWC-56, "POWER WINDOW MAIN SWITCH : Diagnosis Procedure"](#).

POWER WINDOW MAIN SWITCH : Diagnosis Procedure

INFOID:000000009009768

1. CHECK POWER WINDOW SWITCH INPUT SIGNAL

1. Turn ignition switch ON.
2. Check signal between power window main switch harness connector and ground with oscilloscope.

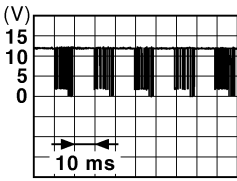
(+) power window main switch		(-)	Signal (Reference value)
Connector	Terminal		
D5	13	Ground	 <p style="text-align: right;">JPMA0013GB</p>

Is the inspection result normal?

YES >> GO TO 4.

NO >> GO TO 2.

2. CHECK POWER WINDOW SERIAL LINK SIGNAL

1. Turn ignition switch OFF.
2. Disconnect power window main switch connector.
3. Turn ignition switch ON.
4. Check voltage between power window main switch harness connector and ground.

(+) Power window main switch		(-)	Voltage (V) (Approx.)
Connector	Terminal		
D5	13	Ground	12

Is the inspection result normal?

YES >> Replace power window main switch. Refer to [PWC-75, "Removal and Installation"](#).

POWER WINDOW SERIAL LINK

< DTC/CIRCUIT DIAGNOSIS >

NO >> GO TO 3.

3.CHECK POWER WINDOW SERIAL LINK CIRCUIT

1. Disconnect BCM connector and power window main switch connector.
2. Check continuity between BCM harness connector and power window main switch harness connector.

BCM		Power window main switch		Continuity
Connector	Terminal	Connector	Terminal	
M68	8	D5	13	Existed

3. Check continuity between BCM harness connector and ground.

BCM		Ground	Continuity
Connector	Terminal		
M68	8		Not existed

Is the inspection result normal?

YES >> Replace BCM. Refer to [BCS-95, "Removal and Installation"](#).

NO >> Repair or replace harness.

4.CHECK INTERMITTENT INCIDENT

Refer to [GI-43, "Intermittent Incident"](#).

>> INSPECTION END

FRONT POWER WINDOW SWITCH (PASSENGER SIDE)

FRONT POWER WINDOW SWITCH (PASSENGER SIDE) : Component Function Check

INFOID:000000009009769

1.CHECK POWER WINDOW SWITCH OUTPUT SIGNAL

With CONSULT

Check ("CDL LOCK SW", "CDL UNLOCK SW") in "DATA MONITOR" mode for "POWER DOOR LOCK SYSTEM" with CONSULT. Refer to [DLK-40, "DOOR LOCK : CONSULT Function \(BCM - DOOR LOCK\)"](#).

PWC

Monitor item	Condition	
CDL LOCK SW	LOCK	: ON
	UNLOCK	: OFF
CDL UNLOCK SW	LOCK	: OFF
	UNLOCK	: ON

Is the inspection result normal?

YES >> Power window serial link is OK.

NO >> Refer to [PWC-57, "FRONT POWER WINDOW SWITCH \(PASSENGER SIDE\) : Diagnosis Procedure"](#).

FRONT POWER WINDOW SWITCH (PASSENGER SIDE) : Diagnosis Procedure

INFOID:000000009009770

1.CHECK POWER WINDOW SWITCH INPUT SIGNAL

1. Turn ignition switch ON.
2. Check signal between front power window switch (passenger side) harness connector and ground with oscilloscope.

POWER WINDOW SERIAL LINK

< DTC/CIRCUIT DIAGNOSIS >

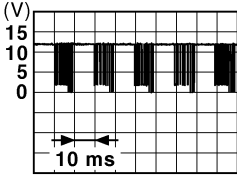
(+)		(-)	Signal (Reference value)
Front power window switch (passenger side)			
Connector	Terminal		
D25	16	Ground	 <p>(V) 15 10 5 0</p> <p>10 ms</p> <p>JPMIA0013GB</p>

Is the inspection result normal?

YES >> Replace front power window switch (passenger side). Refer to [PWC-75, "Removal and Installation"](#).

NO >> GO TO 2.

2.CHECK POWER WINDOW SERIAL LINK SIGNAL

1. Turn ignition switch OFF.
2. Disconnect front power window switch (passenger side) connector.
3. Turn ignition switch ON.
4. Check voltage between front power window switch (passenger side) harness connector and ground.

(+)		(-)	Voltage (V) (Approx.)
Front power window switch (passenger side)			
Connector	Terminal		
D25	16	Ground	12

Is the inspection result normal?

YES >> Replace power window main switch. Refer to [PWC-75, "Removal and Installation"](#).

NO >> GO TO 3.

3.CHECK POWER WINDOW SERIAL LINK CIRCUIT

1. Disconnect power window main switch connector.
2. Check continuity between power window main switch harness connector and front power window switch (passenger side) harness connector.

Power window main switch		Front power window switch (passenger side)		Continuity
Connector	Terminal	Connector	Terminal	
D5	13	D25	16	Existed

3. Check continuity between power window main switch harness connector and ground.

Power window main switch		Ground	Continuity
Connector	Terminal		
D5	13		Not existed

Is the inspection result normal?

YES >> GO TO 4.

NO >> Repair or replace harness.

4.CHECK INTERMITTENT INCIDENT

Refer to [GI-43, "Intermittent Incident"](#).

>> INSPECTION END

REAR POWER WINDOW SWITCH LH

POWER WINDOW SERIAL LINK

< DTC/CIRCUIT DIAGNOSIS >

REAR POWER WINDOW SWITCH LH : Component Function Check

INFOID:000000009009771

1. CHECK POWER WINDOW SWITCH OUTPUT SIGNAL

With CONSULT

Check ("CDL LOCK SW", "CDL UNLOCK SW") in "DATA MONITOR" mode for "POWER DOOR LOCK SYSTEM" with CONSULT. Refer to [DLK-40. "DOOR LOCK : CONSULT Function \(BCM - DOOR LOCK\)"](#).

Monitor item	Condition
CDL LOCK SW	LOCK : ON
	UNLOCK : OFF
CDL UNLOCK SW	LOCK : OFF
	UNLOCK : ON

Is the inspection result normal?

YES >> Power window serial link is OK.

NO >> Refer to [PWC-59. "REAR POWER WINDOW SWITCH LH : Diagnosis Procedure"](#).

REAR POWER WINDOW SWITCH LH : Diagnosis Procedure

INFOID:000000009009772

1. CHECK POWER WINDOW SWITCH INPUT SIGNAL

- Turn ignition switch ON.
- Check signal between rear power window switch LH harness connector and ground with oscilloscope.

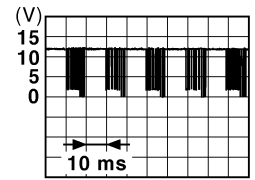
(+)		(-)	Signal (Reference value)
Connector	Terminal		
D63	16	Ground	 <p style="text-align: right;">JPMA0013GB</p>

Is the inspection result normal?

YES >> Replace rear power window switch LH. Refer to [PWC-75. "Removal and Installation"](#).

NO >> GO TO 2.

2. CHECK POWER WINDOW SERIAL LINK SIGNAL

- Turn ignition switch OFF.
- Disconnect rear power window switch LH connector.
- Turn ignition switch ON.
- Check voltage between rear power window switch LH harness connector and ground.

(+)		(-)	Voltage (V) (Approx.)
Connector	Terminal		
D63	16	Ground	12

Is the inspection result normal?

YES >> Replace power window main switch. Refer to [PWC-75. "Removal and Installation"](#).

NO >> GO TO 3.

3. CHECK POWER WINDOW SERIAL LINK CIRCUIT

- Disconnect power window main switch connector.

A
B
C
D
E
F
G
H
I
J
L
M
N
O
P



POWER WINDOW SERIAL LINK

< DTC/CIRCUIT DIAGNOSIS >

2. Check continuity between power window main switch harness connector and rear power window switch LH harness connector.

Power window main switch		Rear power window switch LH		Continuity
Connector	Terminal	Connector	Terminal	
D5	13	D63	16	Existed

3. Check continuity between power window main switch harness connector and ground.

Power window main switch		Ground	Continuity
Connector	Terminal		
D5	13		Not existed

Is the inspection result normal?

- YES >> GO TO 4.
 NO >> Repair or replace harness.

4.CHECK INTERMITTENT INCIDENT

Refer to [GI-43. "Intermittent Incident"](#).

>> INSPECTION END

REAR POWER WINDOW SWITCH RH

REAR POWER WINDOW SWITCH RH : Component Function Check

INFOID:000000009009773

1.CHECK POWER WINDOW SWITCH OUTPUT SIGNAL

With CONSULT

Check ("CDL LOCK SW ", "CDL UNLOCK SW") in "DATA MONITOR" mode for "POWER DOOR LOCK SYSTEM" with CONSULT. Refer to [DLK-40. "DOOR LOCK : CONSULT Function \(BCM - DOOR LOCK\)"](#).

Monitor item	Condition	
CDL LOCK SW	LOCK	: ON
	UNLOCK	: OFF
CDL UNLOCK SW	LOCK	: OFF
	UNLOCK	: ON

Is the inspection result normal?

- YES >> Power window serial link is OK.
 NO >> Refer to [PWC-60. "REAR POWER WINDOW SWITCH RH : Diagnosis Procedure"](#).

REAR POWER WINDOW SWITCH RH : Diagnosis Procedure

INFOID:000000009009774

1.CHECK POWER WINDOW SWITCH INPUT SIGNAL

1. Turn ignition switch ON.
2. Check signal between rear power window switch RH harness connector and ground with oscilloscope.

POWER WINDOW SERIAL LINK

< DTC/CIRCUIT DIAGNOSIS >

(+)		(-)	Signal (Reference value)
Rear power window switch RH			
Connector	Terminal		
D43	16	Ground	<p style="text-align: right; font-size: small;">JPMA0013GB</p>

Is the inspection result normal?

- YES >> Replace rear power window switch RH. Refer to [PWC-75, "Removal and Installation"](#).
 NO >> GO TO 2.

2.CHECK POWER WINDOW SERIAL LINK SIGNAL

1. Turn ignition switch OFF.
2. Disconnect rear power window switch RH connector.
3. Turn ignition switch ON.
4. Check voltage between rear power window switch RH harness connector and ground.

(+)		(-)	Voltage (V) (Approx.)
Rear power window switch RH			
Connector	Terminal		
D43	16	Ground	12

Is the inspection result normal?

- YES >> Replace power window main switch. Refer to [PWC-75, "Removal and Installation"](#).
 NO >> GO TO 3.

3.CHECK POWER WINDOW SERIAL LINK CIRCUIT

1. Disconnect power window main switch connector.
2. Check continuity between power window main switch harness connector and rear power window switch RH harness connector.

Power window main switch		Rear power window switch RH		Continuity
Connector	Terminal	Connector	Terminal	
D5	13	D43	16	Existed

3. Check continuity between power window main switch harness connector and ground.

Power window main switch		Ground	Continuity
Connector	Terminal		
D5	13		Not existed

Is the inspection result normal?

- YES >> GO TO 4.
 NO >> Repair or replace harness.

4.CHECK INTERMITTENT INCIDENT

Refer to [GI-43, "Intermittent Incident"](#).

>> INSPECTION END

POWER WINDOWS DO NOT OPERATE WITH POWER WINDOW MAIN SWITCH

< SYMPTOM DIAGNOSIS >

SYMPTOM DIAGNOSIS

POWER WINDOWS DO NOT OPERATE WITH POWER WINDOW MAIN SWITCH

Diagnosis Procedure

INFOID:000000009009775

1. CHECK BCM POWER SUPPLY AND GROUND CIRCUIT

Check BCM power supply and ground circuit.

[BCS-95. "Removal and Installation"](#).

Is the inspection result normal?

YES >> GO TO 2.

NO >> Repair or replace the malfunctioning parts.

2. CHECK POWER WINDOW MAIN SWITCH POWER SUPPLY AND GROUND CIRCUIT

Check power window switch power supply and ground circuit.

Refer to [PWC-36. "POWER WINDOW MAIN SWITCH : Diagnosis Procedure"](#).

Is the inspection result normal?

YES >> GO TO 3.

NO >> Repair or replace the malfunctioning parts.

3. CHECK POWER WINDOW MAIN SWITCH SERIAL LINK CIRCUIT

Check power window serial link circuit.

Refer to [PWC-56. "POWER WINDOW MAIN SWITCH : Component Function Check"](#).

Is the inspection result normal?

YES >> GO TO 4.

NO >> Repair or replace the malfunctioning parts.

4. CONFIRM THE OPERATION

Confirm the operation again.

Is the result normal?

YES >> Check intermittent incident. Refer to [GI-43. "Intermittent Incident"](#).

NO >> GO TO 1.

DRIVER SIDE POWER WINDOW ALONE DOES NOT OPERATE

< SYMPTOM DIAGNOSIS >

DRIVER SIDE POWER WINDOW ALONE DOES NOT OPERATE

Diagnosis Procedure

INFOID:000000009009776

1. CHECK DRIVER SIDE POWER WINDOW MOTOR

Check driver side power window motor.

Refer to [PWC-40, "DRIVER SIDE : Component Function Check"](#).

Is the measurement value within the specification?

YES >> GO TO 2.

NO >> Repair or replace the malfunctioning parts.

2. CONFIRM THE OPERATION

Confirm the operation again.

Is the result normal?

YES >> Check intermittent incident. Refer to [GI-43, "Intermittent Incident"](#).

NO >> GO TO 1.

A
B
C
D
E
F
G
H
I
J
L
M
N
O
P

PWC

FRONT PASSENGER SIDE POWER WINDOW DOES NOT OPERATE

< SYMPTOM DIAGNOSIS >

FRONT PASSENGER SIDE POWER WINDOW DOES NOT OPERATE WHEN POWER WINDOW MAIN SWITCH IS OPERATED

WHEN POWER WINDOW MAIN SWITCH IS OPERATED : Diagnosis Procedure

INFOID:000000009009777

1. CHECK FRONT POWER WINDOW SWITCH (PASSENGER SIDE) SERIAL LINK CIRCUIT

Check front power window switch (passenger side) serial link circuit.

Refer to [PWC-57. "FRONT POWER WINDOW SWITCH \(PASSENGER SIDE\) : Component Function Check"](#).

Is the inspection result normal?

YES >> GO TO 2.

NO >> Repair or replace the malfunctioning parts.

2. CONFIRM THE OPERATION

Confirm the operation again.

Is the result normal?

YES >> Check intermittent incident. Refer to [GI-43. "Intermittent Incident"](#).

NO >> GO TO 1.

WHEN FRONT POWER WINDOW SWITCH (PASSENGER SIDE) IS OPERATED

WHEN FRONT POWER WINDOW SWITCH (PASSENGER SIDE) IS OPERATED :
Diagnosis Procedure

INFOID:000000009009778

1. REPLACE FRONT POWER WINDOW SWITCH (PASSENGER SIDE)

Replace front power window switch (passenger side).

Refer to [PWC-75. "Removal and Installation"](#)

>> INSPECTION END

WHEN BOTH POWER WINDOW MAIN SWITCH AND FRONT POWER WINDOW SWITCH ARE OPERATED

WHEN BOTH POWER WINDOW MAIN SWITCH AND FRONT POWER WINDOW
SWITCH ARE OPERATED : Diagnosis Procedure

INFOID:000000009009779

1. CHECK FRONT POWER WINDOW SWITCH (PASSENGER SIDE) POWER SUPPLY AND GROUND CIR- CUIT

Check front power window switch (passenger side) power supply and ground circuit.

Refer to [PWC-37. "FRONT POWER WINDOW SWITCH \(PASSENGER SIDE\) : Diagnosis Procedure"](#).

Is the inspection result normal?

YES >> GO TO 2.

NO >> Repair or replace the malfunctioning parts.

2. CHECK PASSENGER SIDE POWER WINDOW MOTOR CIRCUIT

Check passenger side power window motor circuit.

Refer to [PWC-41. "PASSENGER SIDE : Component Function Check"](#).

Is the inspection result normal?

YES >> GO TO 3.

NO >> Repair or replace the malfunctioning parts.

3. CONFIRM THE OPERATION

Confirm the operation again.

Is the result normal?

YES >> Check intermittent incident. Refer to [GI-43. "Intermittent Incident"](#).

NO >> GO TO 1.

REAR LH SIDE POWER WINDOW ALONE DOES NOT OPERATE

< SYMPTOM DIAGNOSIS >

REAR LH SIDE POWER WINDOW ALONE DOES NOT OPERATE WHEN POWER WINDOW MAIN SWITCH IS OPERATED

WHEN POWER WINDOW MAIN SWITCH IS OPERATED : Diagnosis Procedure

INFOID:000000009009780

1. CHECK REAR POWER WINDOW SWITCH LH SERIAL LINK CIRCUIT

Check rear power window switch LH serial link circuit.

Refer to [PWC-59, "REAR POWER WINDOW SWITCH LH : Component Function Check"](#).

Is the inspection result normal?

YES >> GO TO 2.

NO >> Repair or replace the malfunctioning parts.

2. CONFIRM THE OPERATION

Confirm the operation again.

Is the result normal?

YES >> Check intermittent incident. Refer to [GI-43, "Intermittent Incident"](#).

NO >> GO TO 1.

WHEN REAR POWER WINDOW SWITCH LH IS OPERATED

WHEN REAR POWER WINDOW SWITCH LH IS OPERATED : Diagnosis Procedure

INFOID:000000009009781

1. REPLACE REAR POWER WINDOW SWITCH LH

Replace rear power window switch LH.

Refer to [PWC-75, "Removal and Installation"](#)

>> INSPECTION END

WHEN BOTH POWER WINDOW MAIN SWITCH AND REAR POWER WINDOW SWITCH LH ARE OPERATED

WHEN BOTH POWER WINDOW MAIN SWITCH AND REAR POWER WINDOW
SWITCH LH ARE OPERATED : Diagnosis Procedure

INFOID:000000009009782

PWC

1. CHECK REAR POWER WINDOW SWITCH POWER SUPPLY AND GROUND CIRCUIT

Check rear power window switch power supply and ground circuit.

Refer to [PWC-38, "REAR POWER WINDOW SWITCH : Diagnosis Procedure"](#).

Is the inspection result normal?

YES >> GO TO 2.

NO >> Repair or replace the malfunctioning parts.

2. CHECK REAR POWER WINDOW MOTOR LH

Check rear power window motor LH.

Refer to [PWC-42, "REAR LH : Component Function Check"](#).

Is the inspection result normal?

YES >> GO TO 3.

NO >> Repair or replace the malfunctioning parts.

3. CONFIRM THE OPERATION

Confirm the operation again.

Is the result normal?

YES >> Check intermittent incident. Refer to [GI-43, "Intermittent Incident"](#).

NO >> GO TO 1.

REAR RH SIDE POWER WINDOW ALONE DOES NOT OPERATE

< SYMPTOM DIAGNOSIS >

REAR RH SIDE POWER WINDOW ALONE DOES NOT OPERATE WHEN POWER WINDOW MAIN SWITCH IS OPERATED

WHEN POWER WINDOW MAIN SWITCH IS OPERATED : Diagnosis Procedure

INFOID:000000009009783

1.CHECK REAR POWER WINDOW SWITCH RH SERIAL LINK CIRCUIT

Check rear power window switch RH serial link circuit.

Refer to [PWC-60. "REAR POWER WINDOW SWITCH RH : Component Function Check"](#).

Is the inspection result normal?

YES >> GO TO 2.

NO >> Repair or replace the malfunctioning parts.

2.CONFIRM THE OPERATION

Confirm the operation again.

Is the result normal?

YES >> Check intermittent incident. Refer to [GI-43. "Intermittent Incident"](#).

NO >> GO TO 1.

WHEN REAR POWER WINDOW SWITCH RH IS OPERATED

WHEN REAR POWER WINDOW SWITCH RH IS OPERATED : Diagnosis Procedure

INFOID:000000009009784

1.REPLACE REAR POWER WINDOW SWITCH RH

Replace rear power window switch RH.

Refer to [PWC-75. "Removal and Installation"](#)

>> INSPECTION END

WHEN BOTH POWER WINDOW MAIN SWITCH AND REAR POWER WINDOW SWITCH RH ARE OPERATED

WHEN BOTH POWER WINDOW MAIN SWITCH AND REAR POWER WINDOW
SWITCH RH ARE OPERATED : Diagnosis Procedure

INFOID:000000009009785

1.CHECK REAR POWER WINDOW SWITCH POWER SUPPLY AND GROUND CIRCUIT

Check rear power window switch power supply and ground circuit.

Refer to [PWC-38. "REAR POWER WINDOW SWITCH : Diagnosis Procedure"](#).

Is the inspection result normal?

YES >> GO TO 2.

NO >> Repair or replace the malfunctioning parts.

2.CHECK REAR POWER WINDOW MOTOR RH

Check rear power window motor RH.

Refer to [PWC-42. "REAR RH : Component Function Check"](#).

Is the inspection result normal?

YES >> GO TO 3.

NO >> Repair or replace the malfunctioning parts.

3.CONFIRM THE OPERATION

Confirm the operation again.

Is the result normal?

YES >> Check intermittent incident. Refer to [GI-43. "Intermittent Incident"](#).

NO >> GO TO 1.

AUTO OPERATION DOES NOT OPERATE BUT MANUAL OPERATE NORMALLY

< SYMPTOM DIAGNOSIS >

AUTO OPERATION DOES NOT OPERATE BUT MANUAL OPERATE NORMALLY

DRIVER SIDE

DRIVER SIDE : Diagnosis Procedure

INFOID:000000009009786

1.PERFORM INITIALIZATION PROCEDURE

Initialization procedure is performed and operation is confirmed.
Refer to [PWC-34, "Work Procedure"](#).

Is the inspection result normal?

YES >> INSPECTION END
NO >> GO TO 2.

2.CHECK ENCODER (DRIVER SIDE) CIRCUIT

Check encoder (driver side) circuit.
Refer to [PWC-44, "DRIVER SIDE : Component Function Check"](#).

Is the inspection result normal?

YES >> GO TO 3.
NO >> Repair or replace the malfunctioning parts.

3.CONFIRM THE OPERATION

Confirm the operation again.

Is the result normal?

YES >> Check intermittent incident. Refer to [GI-43, "Intermittent Incident"](#).
NO >> GO TO 1.

PASSENGER SIDE

PASSENGER SIDE : Diagnosis Procedure

INFOID:000000009009787

1.PERFORM INITIALIZAITON PROCEDURE

Initialization procedure is performed and operation is confirmed.
Refer to [PWC-34, "Work Procedure"](#).

Is the inspection result normal?

YES >> INSPECTION END
NO >> GO TO 2.

2.CHECK ENCODER (PASSENGER SIDE) CIRCUIT

Check encoder (passenger side) circuit.
Refer to [PWC-46, "PASSENGER SIDE : Component Function Check"](#).

Is the inspection result normal?

YES >> GO TO 3.
NO >> Repair or replace the malfunctioning parts.

3.CONFIRM THE OPERATION

Confirm the operation again.

Is the result normal?

YES >> Check intermittent incident. Refer to [GI-43, "Intermittent Incident"](#).
NO >> GO TO 1.

REAR LH

REAR LH : Diagnosis Procedure

INFOID:000000009009788

1.PERFORM INITIALIZATION PROCEDURE

Initialization procedure is performed and operation is confirmed.

A
B
C
D
E
F
G
H
I
J
L
M
N
O
P

PWC

AUTO OPERATION DOES NOT OPERATE BUT MANUAL OPERATE NORMALLY

< SYMPTOM DIAGNOSIS >

Refer to [PWC-34. "Work Procedure"](#)

Is the inspection result normal?

- YES >> INSPECTION END
- NO >> GO TO 2.

2.CHECK ENCODER (REAR LH) CIRCUIT

Check encoder (rear LH) circuit.

Refer to [PWC-49. "REAR LH : Component Function Check"](#).

Is the inspection result normal?

- YES >> GO TO 3.
- NO >> Repair or replace the malfunctioning parts.

3.CONFIRM THE OPERATION

Confirm the operation again.

Is the result normal?

- YES >> Check intermittent incident. Refer to [GI-43. "Intermittent Incident"](#).
- NO >> GO TO 1.

REAR RH

REAR RH : Diagnosis Procedure

INFOID:000000009009789

1.PERFORM INITIALIZATION PROCEDURE

Initialization procedure is performed and operation is confirmed.

Refer to [PWC-34. "Work Procedure"](#).

Is the inspection result normal?

- YES >> INSPECTION END
- NO >> GO TO 2.

2.CHECK ENCODER (REAR RH) CIRCUIT

Check encoder (rear RH) circuit.

Refer to [PWC-51. "REAR RH : Component Function Check"](#).

Is the inspection result normal?

- YES >> GO TO 3.
- NO >> Repair or replace the malfunctioning parts.

3.CONFIRM THE OPERATION

Confirm the operation again.

Is the result normal?

- YES >> Check intermittent incident. Refer to [GI-43. "Intermittent Incident"](#).
- NO >> GO TO 1.

ANTI-PINCH FUNCTION DOES NOT OPERATE

< SYMPTOM DIAGNOSIS >

ANTI-PINCH FUNCTION DOES NOT OPERATE

Diagnosis Procedure

INFOID:000000009009790

1. CHECK POWER WINDOW AUTO OPERATION

Check AUTO operation of the door when anti-pinch function does not operate.

Is the inspection result normal?

YES >> GO TO 2.

NO >> Refer to [PWC-67, "DRIVER SIDE : Diagnosis Procedure"](#) (driver side), [PWC-67, "PASSENGER SIDE : Diagnosis Procedure"](#) (passenger side), [PWC-67, "REAR LH : Diagnosis Procedure"](#) (rear LH), [PWC-68, "REAR RH : Diagnosis Procedure"](#) (rear RH).

2. CONFIRM THE OPERATION

Confirm the operation again.

Is the inspection result normal?

YES >> Check intermittent incident. Refer to [GI-43, "Intermittent Incident"](#).

NO >> GO TO 1.

A
B
C
D
E
F
G
H
I
J
L
M
N
O
P

PWC

POWER WINDOW RETAINED POWER FUNCTION DOES NOT OPERATE NORMALLY

< SYMPTOM DIAGNOSIS >

POWER WINDOW RETAINED POWER FUNCTION DOES NOT OPERATE NORMALLY

Diagnosis Procedure

INFOID:000000009009791

1. CHECK DOOR SWITCH

Check door switch.

Refer to [DLK-119, "Component Function Check"](#).

Is the inspection result normal?

YES >> GO TO 2.

NO >> Repair or replace the malfunctioning parts.

2. CONFIRM THE OPERATION

Confirm the operation again.

Is the result normal?

YES >> Check intermittent incident. Refer to [GI-43, "Intermittent Incident"](#).

NO >> GO TO 1.

DOOR KEY CYLINDER SWITCH DOES NOT OPERATE POWER WINDOWS

< SYMPTOM DIAGNOSIS >

DOOR KEY CYLINDER SWITCH DOES NOT OPERATE POWER WINDOWS

Diagnosis Procedure

INFOID:000000009009792

1.PERFORM INITIALIZATION PROCEDURE

Initialization procedure is performed and operation is confirmed.

Refer to [PWC-34, "Work Procedure"](#)

Is the inspection result normal?

YES >> INSPECTION END

NO >> GO TO 2.

2.CHECK DRIVER SIDE DOOR LOCK ASSEMBLY (DOOR KEY CYLINDER SWITCH)

Check front door lock assembly (driver side) (door key cylinder switch).

Refer to [PWC-54, "Component Function Check"](#).

Is the inspection result normal?

YES >> GO TO 3.

NO >> Repair or replace the malfunctioning parts.

3.CONFIRM THE OPERATION

Confirm the operation again.

Is the result normal?

YES >> Check intermittent incident. Refer to [GI-43, "Intermittent Incident"](#).

NO >> GO TO 1.

A
B
C
D
E
F
G
H
I
J
L
M
N
O
P

PWC

KEYLESS POWER WINDOW DOWN DOES NOT OPERATE

< SYMPTOM DIAGNOSIS >

KEYLESS POWER WINDOW DOWN DOES NOT OPERATE

Diagnosis Procedure

INFOID:000000009009793

1. CHECK REMOTE KEYLESS ENTRY FUNCTION

Check remote keyless entry function.

Does door lock/unlock with Intelligent key button?

YES >> GO TO 2.

NO >> Refer to [DLK-180, "Diagnosis Procedure"](#).

2. CHECK POWER WINDOW OPERATION

Check power window operation.

Does power window up/down with power window main switch?

YES >> GO TO 3.

NO >> Refer to [PWC-36, "POWER WINDOW MAIN SWITCH : Diagnosis Procedure"](#).

3. CHECK "PW DOWN SET" SETTING IN "WORK SUPPORT"

Check "PW DOWN SET" setting in "WORK SUPPORT".

Refer to [DLK-42, "INTELLIGENT KEY : CONSULT Function \(BCM - INTELLIGENT KEY\)"](#).

Is the inspection result normal?

YES >> GO TO 4.

NO >> Set "PW DOWN SET" setting in "WORK SUPPORT".

4. CONFIRM THE OPERATION

Confirm the operation again.

Is the result normal?

YES >> Check intermittent incident. Refer to [GI-43, "Intermittent Incident"](#).

NO >> GO TO 1.

POWER WINDOW LOCK SWITCH DOES NOT FUNCTION

< SYMPTOM DIAGNOSIS >

POWER WINDOW LOCK SWITCH DOES NOT FUNCTION

Diagnosis Procedure

INFOID:000000009009794

1.REPLACE POWER WINDOW MAIN SWITCH

Replace power window main switch. Refer to [PWC-75, "Removal and Installation"](#).

>> INSPECTION END

A
B
C
D
E
F
G
H
I
J
L
M
N
O
P

PWC

POWER WINDOW SWITCH DOES NOT ILLUMINATE

< SYMPTOM DIAGNOSIS >

POWER WINDOW SWITCH DOES NOT ILLUMINATE

DRIVER SIDE

DRIVER SIDE : Diagnosis Procedure

INFOID:000000009009795

1.REPLACE POWER WINDOW MAIN SWITCH

Replace power window main switch.
Refer to [PWC-75. "Removal and Installation"](#).

>> INSPECTION END

PASSENGER SIDE

PASSENGER SIDE : Diagnosis Procedure

INFOID:000000009009796

1.REPLACE FRONT POWER WINDOW SWITCH (PASSENGER SIDE)

Replace front power window switch (passenger side).
Refer to [PWC-75. "Removal and Installation"](#).

>> INSPECTION END

REAR LH

REAR LH : Diagnosis Procedure

INFOID:000000009009797

1.REPLACE REAR POWER WINDOW SWITCH LH

Replace rear power window switch LH.
Refer to [PWC-75. "Removal and Installation"](#).

>> INSPECTION END

REAR RH

REAR RH : Diagnosis Procedure

INFOID:000000009009798

1.REPLACE REAR POWER WINDOW SWITCH RH

Replace rear power window switch RH.
Refer to [PWC-75. "Removal and Installation"](#).

>> INSPECTION END

POWER WINDOW MAIN SWITCH

< REMOVAL AND INSTALLATION >

REMOVAL AND INSTALLATION

POWER WINDOW MAIN SWITCH

Removal and Installation

INFOID:000000009009799

REMOVAL

1. Remove the front door finisher.
Refer to [INT-14, "Removal and Installation"](#).
2. Disconnect power window main switch fixing screws to remove power window main switch.

INSTALLATION

Install in the reverse order of removal.

NOTE:

When power window main switch is replaced or is removed, it is necessary to do the initialization procedure.
Refer to [PWC-34, "Work Procedure"](#).

A

B

C

D

E

F

G

H

I

J

PWC

L

M

N

O

P

FRONT POWER WINDOW SWITCH (PASSENGER SIDE)

< REMOVAL AND INSTALLATION >

FRONT POWER WINDOW SWITCH (PASSENGER SIDE)

Removal and Installation

INFOID:000000009009800

REMOVAL

1. Remove the front door finisher.
Refer to [INT-14, "Removal and Installation"](#).
2. Disconnect front power window switch (passenger side) fixing screws to remove front power window switch (passenger side).

INSTALLATION

Install in the reverse order of removal.

REAR POWER WINDOW SWITCH

< REMOVAL AND INSTALLATION >

REAR POWER WINDOW SWITCH

Removal and Installation

INFOID:000000009009801

REMOVAL

1. Remove the rear door finisher.
Refer to [INT-16, "Removal and Installation"](#).
2. Remove rear power window switch finisher from rear door finisher.
Refer to [INT-16, "Removal and Installation"](#).
3. Disengage pawls of rear power window switch finisher using remover tool to remove rear power window switch.

CAUTION:

Never fold the pawl of rear power window switch finisher.

NOTE:

The same procedure is also performed for rear power window switch LH and RH.

INSTALLATION

Install in the reverse order of removal.

A
B
C
D
E
F
G
H
I
J
L
M
N
O
P

PWC