

A

SECTION STR

STR

STARTING SYSTEM

C

CONTENTS

D

E

PRECAUTION	BASIC INSPECTION	F
PRECAUTIONS	DIAGNOSIS AND REPAIR WORK FLOW	
Precaution for Supplemental Restraint System (SRS) "AIR BAG" and "SEAT BELT PRE-TENSIONER"	Work Flow (With GR8-1200 NI)	G
Precaution for Procedure without Cowl Top Cover.....	Work Flow (Without GR8-1200 NI)	
Precautions for Removing Battery Terminal	DTC/CIRCUIT DIAGNOSIS	H
Precautions When Battery Is Discharged	B TERMINAL CIRCUIT	
PREPARATION	Diagnosis Procedure	I
PREPARATION	S CONNECTOR CIRCUIT	
Special Service Tools	Diagnosis Procedure	J
Commercial Service Tools	SYMPTOM DIAGNOSIS	
SYSTEM DESCRIPTION	STARTING SYSTEM	K
COMPONENT PARTS	Symptom Table	
Component Parts Location	REMOVAL AND INSTALLATION	L
Component Description	STARTER MOTOR	
SYSTEM	Exploded View	M
System Diagram	Removal and Installation	
System Description	SERVICE DATA AND SPECIFICATIONS (SDS)	N
WIRING DIAGRAM	SERVICE DATA AND SPECIFICATIONS (SDS)	
STARTING SYSTEM	Starter Motor	O
Wiring Diagram		P

PRECAUTIONS

< PRECAUTION >

PRECAUTION

PRECAUTIONS

Precaution for Supplemental Restraint System (SRS) "AIR BAG" and "SEAT BELT PRE-TENSIONER"

INFOID:000000010260557

The Supplemental Restraint System such as "AIR BAG" and "SEAT BELT PRE-TENSIONER", used along with a front seat belt, helps to reduce the risk or severity of injury to the driver and front passenger for certain types of collision. Information necessary to service the system safely is included in the "SRS AIR BAG" and "SEAT BELT" of this Service Manual.

WARNING:

Always observe the following items for preventing accidental activation.

- To avoid rendering the SRS inoperative, which could increase the risk of personal injury or death in the event of a collision that would result in air bag inflation, all maintenance must be performed by an authorized NISSAN/INFINITI dealer.
- Improper maintenance, including incorrect removal and installation of the SRS, can lead to personal injury caused by unintentional activation of the system. For removal of Spiral Cable and Air Bag Module, see "SRS AIR BAG".
- Never use electrical test equipment on any circuit related to the SRS unless instructed to in this Service Manual. SRS wiring harnesses can be identified by yellow and/or orange harnesses or harness connectors.

PRECAUTIONS WHEN USING POWER TOOLS (AIR OR ELECTRIC) AND HAMMERS

WARNING:

Always observe the following items for preventing accidental activation.

- When working near the Air Bag Diagnosis Sensor Unit or other Air Bag System sensors with the ignition ON or engine running, never use air or electric power tools or strike near the sensor(s) with a hammer. Heavy vibration could activate the sensor(s) and deploy the air bag(s), possibly causing serious injury.
- When using air or electric power tools or hammers, always switch the ignition OFF, disconnect the battery, and wait at least 3 minutes before performing any service.

Precaution for Procedure without Cowl Top Cover

INFOID:000000011507423

When performing the procedure after removing cowl top cover, cover the lower end of windshield with urethane, etc to prevent damage to windshield.

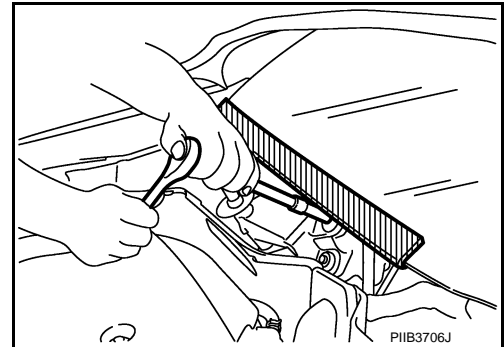

Precautions for Removing Battery Terminal

INFOID:000000010260558

- When removing the 12V battery terminal, turn OFF the ignition switch and wait at least 30 seconds.

NOTE:

ECU may be active for several tens of seconds after the ignition switch is turned OFF. If the battery terminal is removed before ECU stops, then a DTC detection error or ECU data corruption may occur.

- For vehicles with the 2-batteries, be sure to connect the main battery and the sub battery before turning ON the ignition switch.

NOTE:

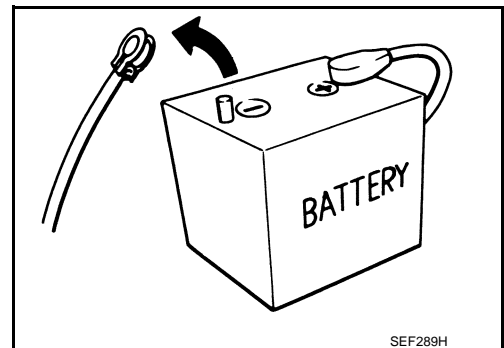

PRECAUTIONS

< PRECAUTION >

If the ignition switch is turned ON with any one of the terminals of main battery and sub battery disconnected, then DTC may be detected.

- After installing the 12V battery, always check "Self Diagnosis Result" of all ECUs and erase DTC.

NOTE:

The removal of 12V battery may cause a DTC detection error.

Precautions When Battery Is Discharged

INFOID:0000000011509582

When battery is discharged, disconnect the negative terminal of the battery and wait for 1 minute before connecting jumper cables to restart the engine. (This is necessary for resetting information in ECM.)

A

STR

C

D

E

F

G

H

I

J

K

L

M

N

O

P

PREPARATION

< PREPARATION >

PREPARATION

PREPARATION

Special Service Tools

INFOID:000000010260559

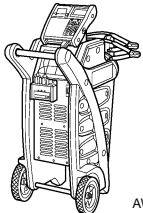
Tool number (TechMate No.) Tool name	Description
<p>— (—) Model GR8-1200 NI Multitasking battery and electrical diagnostic station</p>  <p style="text-align: right;">AWIA1239ZZ</p>	<p>Tests batteries, starting and charging systems and charges batteries. For operating instructions, refer to diagnostic station instruction manual.</p>

Commercial Service Tools

INFOID:000000010260560

Tool name	Description
<p>Power tool</p>  <p style="text-align: right;">PIIB1407E</p>	<p>Loosening bolts, nuts and screws</p>

COMPONENT PARTS

< SYSTEM DESCRIPTION >

SYSTEM DESCRIPTION

COMPONENT PARTS

Component Parts Location

INFOID:000000010260561

A

STR

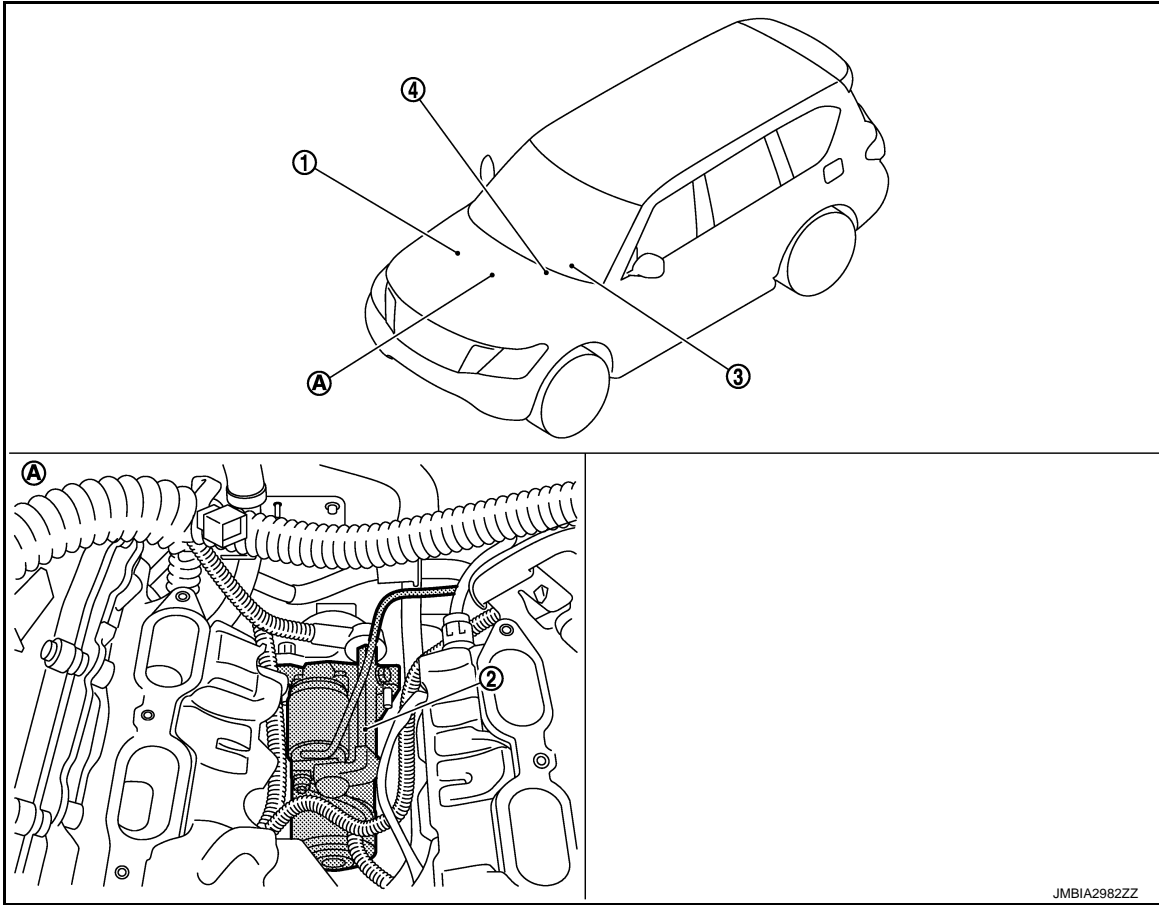

C

D

E

F

G

H

I

J

K

- 1. IPDM E/R
Refer to [PCS-4. "Component Parts Location"](#).
- 2. Starter motor
- 3. TCM
Refer to [TM-11. "A/T CONTROL SYSTEM : Component Parts Location"](#).
- 4. BCM
Refer to [BCS-4. "BODY CONTROL SYSTEM : Component Parts Location"](#).
- A. Engine

L

M

Component Description

INFOID:000000010260562

Component part	Description
BCM	BCM controls the starter relay inside IPDM E/R.
IPDM E/R	CPU inside IPDM E/R controls the starter control relay.
Starter motor	The starter motor plunger closes and the motor is supplied with battery power, which in turn cranks the engine, when the "S" terminal is supplied with electric power.
TCM	TCM supplies power to the starter relay and starter control relay inside IPDM E/R when the selector lever is shifted to the "P" or "N" position.

N

O

P

SYSTEM

< SYSTEM DESCRIPTION >

SYSTEM

System Diagram

INFOID:000000010260563

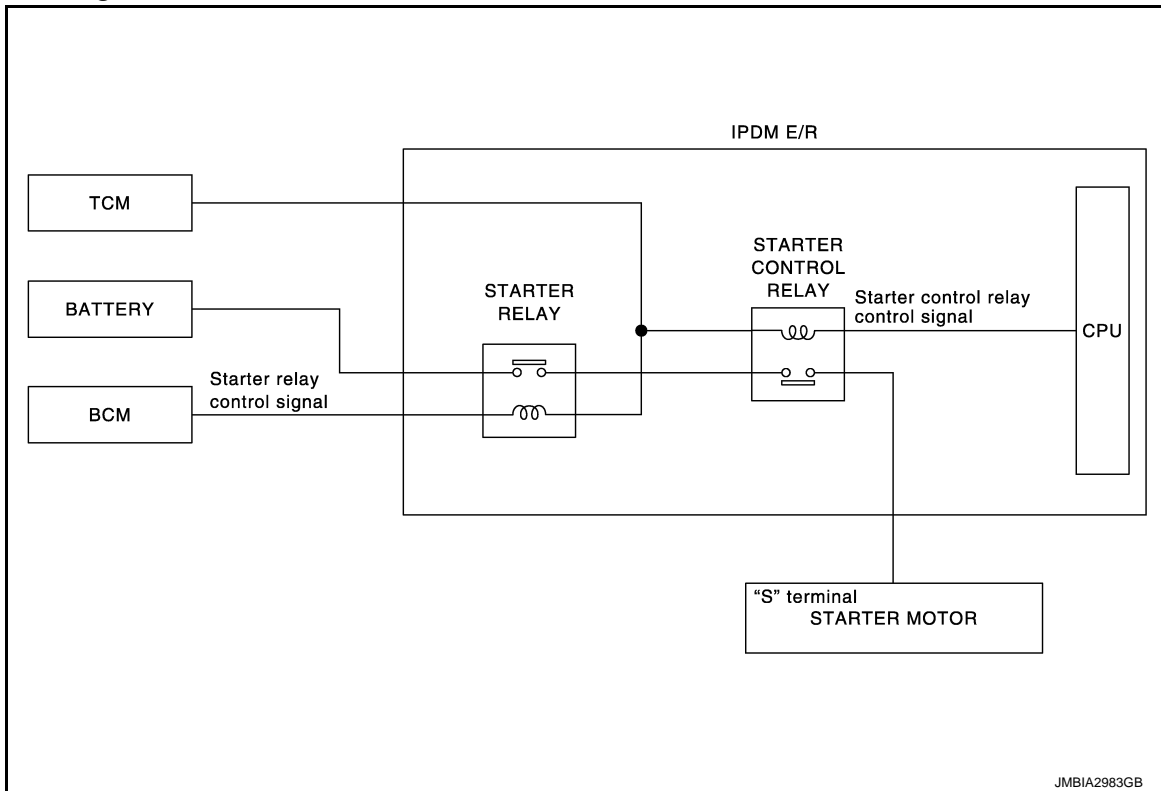

System Description

INFOID:000000010260564

- When selector lever is "P" or "N", power is supplied to starter relay and starter control relay by TCM. And BCM and IPDM E/R (CPU) detect selector lever P/N condition by the inputted signal.
- When starter operating condition is satisfied, IPDM E/R turns starter control relay ON by starter control relay control signal.
- When engine cranking condition is satisfied, BCM turns starter relay ON by starter relay control signal.
- Then battery power is supplied to starter motor ("S" terminal) through starter control relay and starter relay. And IPDM E/R (CPU) detect starter relay condition by the inputted signal.

STARTING SYSTEM

< WIRING DIAGRAM >

WIRING DIAGRAM

STARTING SYSTEM

Wiring Diagram

INFOID:000000010260565

A

STR

C

D

E

F

G

H

I

J

K

L

M

N

O

P

STARTING SYSTEM

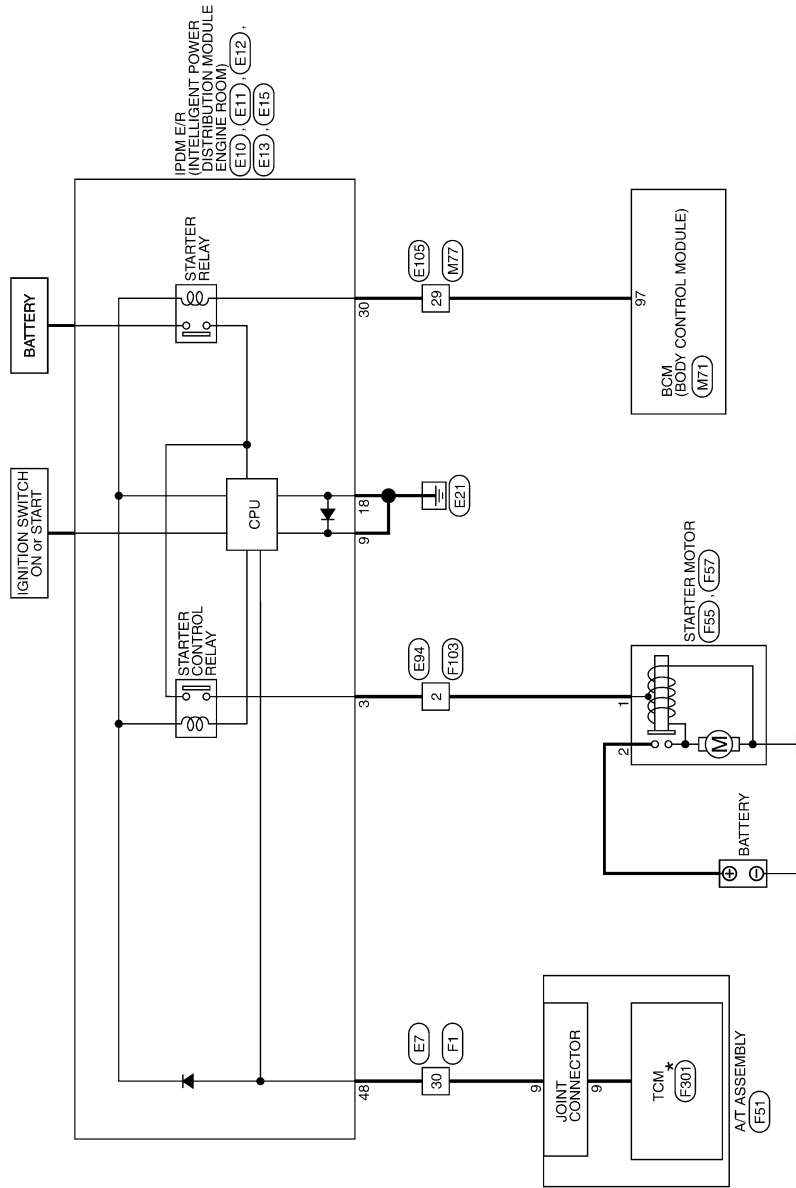

*: This connector is not shown in "Harness Layout".

2014/07/11



JRBWC9595GB

STARTING SYSTEM

< WIRING DIAGRAM >



STARTING SYSTEM

Connector No.	E7
Connector Name	WIRE TO WIRE
Connector Type	TH32MW-NH



Terminal No.	Color Of Wire	Signal Name [Specification]
1	W	-
2	G	-
3	L/O	-
4	LG	-
5	W/L	-
6	G/O	-
7	L/R	-
8	LG/R	-
14	R	-
16	SB	-
17	R/W	-
18	Y/G	-
19	BR/Y	-
20	P/B	-
21	R/B	-
22	Y	-
23	BR	-
24	P/L	VP
29	P	-
30	BR	-
31	L	-
32	P	-

Connector No.	E10
Connector Name	WIRE TO WIRE
Connector Type	M06FW-LC





Terminal No.	Color Of Wire	Signal Name [Specification]
3	R	-
4	L	-
5	P/L	-
7	W/G	-
8	W	-

Connector No.	E11
Connector Name	WIRE TO WIRE
Connector Type	M06FB-LC





Connector No.	E12
Connector Name	WIRE TO WIRE
Connector Type	NS109FBR-CS

Terminal No.	Color Of Wire	Signal Name [Specification]
18	B	-
19	V	-
20	W	-
21	L	-

Connector No.	E13
Connector Name	WIRE TO WIRE
Connector Type	TH12FW-NH

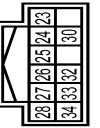

Terminal No.	Color Of Wire	Signal Name [Specification]
23	GR/R	-
24	W/G	-
25	L/Y	-
26	P	-
27	L	-
28	V	-
30	R/W	-
32	LG	-
33	R	-
34	G	-

Connector No.	E15
Connector Name	WIRE TO WIRE
Connector Type	NS116FW-CS

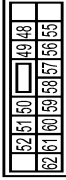
Terminal No.	Color Of Wire	Signal Name [Specification]
48	BR	-
49	R	-
50	LG/B	-
51	BR/Y	-
52	W	-
55	O	-
56	L	-
57	V	-
58	BR/R	-
59	W/B	-
60	V/R	-
61	W	-
62	SB	-

Connector No.	E14
Connector Name	WIRE TO WIRE
Connector Type	M06MW-LC

Terminal No.	Color Of Wire	Signal Name [Specification]
1	G/Y	-
2	R	-
3	V	-
4	R	-
5	G/R	-
6	B/R	-

JRBWC9596GB

STARTING SYSTEM

< WIRING DIAGRAM >

STARTING SYSTEM

Connector No.	E105
Connector Name	WIRE TO WIRE
Connector Type	TH80MW-CS16-TM4

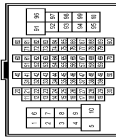

Terminal No.	Color Of Wire	Signal Name [Specification]
1	L	-
2	L/W	-
3	R/B	-
4	L	-
5	Y	-
7	W/G	-
8	P/B	-
9	W/B	-
10	G	-
11	L	-
12	P	-
13	P/B	-
14	BR	-
15	L/B	-
16	SB	-
18	SB	-
19	Y/G	-
20	BR/Y	-
21	Y/V	-
22	L	-
23	Y	-
24	L/W	-
28	O	-
29	R/W	-
30	L/B	-
31	GR/R	-
32	GR/R	-
34	Y	-
35	R	-
36	B/R	-
37	G/Y	-
38	G	-
40	SB	-
41	W/R	-
42	R	-
43	V	-

54	GR/L	-
91	BR	-
92	L/W	-
94	Y/B	-
95	G/R	-
97	R	-
98	G/B	-
100	W/R	-

Connector No.	F1
Connector Name	WIRE TO WIRE
Connector Type	TH32FW-NH



16	13	14	13	12	11	10	9	8	7	6	5	4	3	2	1
33	31	30	29	28	27	26	25	24	23	22	21	20	19	18	17

Terminal No.	Color Of Wire	Signal Name [Specification]
1	W	-
2	G	-
3	L/O	-
4	LG	-
5	W/L	-
6	G/O	-
7	L/R	-
8	LG/R	-
14	R	-
16	SB	-
17	R/W	-
18	Y/G	-
19	BR/Y	-
20	P/B	-
21	R/B	-
22	BR/W	-
24	P/L	-
29	P	-
30	BR	-
31	L	-
32	P	-

Connector No.	F51
Connector Name	A/T ASSEMBLY
Connector Type	RK10FG



5	4	3	2	1
10	9	8	7	6

Terminal No.	Color Of Wire	Signal Name [Specification]
1	V	IGNITION POWER SUPPLY
2	P	BATTERY POWER SUPPLY
3	L	CAN-H
4	SE	K-LINE
5	B	GROUND
6	V	IGNITION POWER SUPPLY
7	R	BACK-UP LAMP RELAY
8	P	CAN-L
9	BR	STARTER RELAY
10	B	GROUND

Connector No.	F55
Connector Name	STARTER MOTOR
Connector Type	X01FGY



Terminal No.	Color Of Wire	Signal Name [Specification]
1	R	-

Connector No.	F57
Connector Name	STARTER MOTOR
Connector Type	E-BA506



2

Terminal No.	Color Of Wire	Signal Name [Specification]
2	B/R	-

Connector No.	F103
Connector Name	WIRE TO WIRE
Connector Type	M06FW-LC



3	2	1
6	5	4

Terminal No.	Color Of Wire	Signal Name [Specification]
1	G/Y	-
2	R	-
3	V	-
4	R	-
5	G/R	-
6	B/R	-

JRBWC9597GB

A
STR
C
D
E
F
G
H
I
J
K
L
M
N
O
P

STARTING SYSTEM

< WIRING DIAGRAM >

STARTING SYSTEM

Connector No.	F301
Connector Name	TCM
Connector Type	SPTDFG



Terminal No.	Color Of Wire	Signal Name [Specification]
1	-	IGNITION POWER SUPPLY
2	-	BATTERY POWER SUPPLY
3	-	CAN-H
4	-	K-LINE
5	-	GROUND
6	-	IGNITION POWER SUPPLY
7	-	BACK-UP LAMP RELAY
8	-	CAN-L
9	-	STARTER RELAY
10	-	GROUND



Connector No.	M71
Connector Name	BCM (BODY CONTROL MODULE)
Connector Type	TH40FW-NH

81	Y/R	PASSENGER DOOR ANT-
82	W/G	BACK DOOR ANT+
83	B/W	BACK DOOR ANT-
84	BR	ROOM ANT1+
85	Y	ROOM ANT1-
86	W	ROOM ANT2+
87	B	ROOM ANT2-
88	V	Luggage ROOM ANT+
89	G	Luggage ROOM ANT-
90	Y	PUSH-BTN IGN SW ILL PWR
91	O	LOCKING
92	V	LOW SIDE PUSHER
93	GR/R	F-KEY WARN BUZZER
96	BR	ACC RELAY CONT
97	R/W	STARTER RELAY CONT
98	O	IGN RELAY IPDM E/B CONT
99	R	IGN RELAY I/F/B CONT
100	P/L	PASSENGER DOOR REQUEST SW
101	W/B	IGN PWR SPLY 2
102	BR	SHIFT N/P
104	R/B	A/T SHIFT SELECT PWR SPLY
105	O/L	STOP LAMP SW 2
106	Y/G	BLWR FAN MTR RELAY CONT
109	L/W	ACC IND
110	BR	RECEIVER PWR SPLY

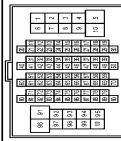

Connector No.	M77
Connector Name	WIRE TO WIRE
Connector Type	TH80FW-CS16-TM4

11	L	-
12	P	-
13	P/B	-
14	BR	-
15	O/L	-
16	SB	-
18	BR	-
19	Y/G	-
20	BR/Y	-
21	Y	-
22	Y	-
23	Y	-
24	L/W	-
28	O	-
29	R/W	-
30	O/L	-
31	Y	-
32	GR/R	-
34	Y	-
35	R	-
36	B/O	-
37	G/Y	-
38	G	-
40	SB	-
41	W/R	-
42	R	-
43	V	-
54	GR/L	-
81	BR	-
92	L/W	-
94	Y/B	-
95	L/R	-
97	R	-
98	O/L	-
100	W/B	-

Terminal No.	Color Of Wire	Signal Name [Specification]
1	W	-
2	L/W	-
3	R/B	-
4	L	-
5	Y	-
7	W/G	-
8	P/B	-
9	W/B	-
10	G	-

Terminal No.	Color Of Wire	Signal Name [Specification]
71	G/R	KYLS ENT RECEIVER COMM
72	P	PUDDLE LAMP CONT
73	W	ON IND
74	Y/B	TRAILER TURN SIG RH CONT
75	LG/R	DRIVER DOOR REQUEST SW
76	SB	PUSH SW
77	O/L	TRAILER TURN SIG LH CONT
78	P/B	DRIVER DOOR ANT+
79	V	DRIVER DOOR ANT-
80	LG/B	PASSENGER DOOR ANT+

JRBWC9598GB

DIAGNOSIS AND REPAIR WORK FLOW

< BASIC INSPECTION >

BASIC INSPECTION

DIAGNOSIS AND REPAIR WORK FLOW

Work Flow (With GR8-1200 NI)

INFOID:0000000010260566

A

STR

STARTING SYSTEM DIAGNOSIS WITH GR8-1200 NI

To test the starting system, use the following special service tool:

- GR8-1200 NI Multitasking battery and electrical diagnostic station

NOTE:

Refer to the diagnostic station Instruction Manual for proper starting system diagnosis procedures.

C

D

E

F

G

H

I

J

K

L

M

N

O

P

DIAGNOSIS AND REPAIR WORK FLOW

< BASIC INSPECTION >

Perform the starting system test with Multitasking battery and electrical diagnostic station GR8-1200 NI. For details and operating instructions, refer to diagnostic station Instruction Manual.

Test result

CRANKING NORMAL>>GO TO 2.

LOW VOLTAGE>>GO TO 5.

CHARGE BATTERY>>Perform the slow battery charging procedure. (Initial rate of charge is 10A for 12 hours.) Perform battery test again. Refer to diagnostic station instruction manual.

REPLACE BATTERY>>Before replacing battery, clean the battery cable clamps and battery posts. Perform battery test again. Refer to diagnostic station instruction manual. If second test result is "REPLACE BATTERY", then do so. Perform battery test again to confirm repair.

2. CRANKING CHECK

Check that the starter motor operates correctly.

Does the engine crank normally?

YES >> GO TO 3.

NO >> GO TO 4.

3. ENGINE START CHECK

Check that the engine starts.

Does the engine start?

YES >> Starter motor is OK. INSPECTION END

NO >> Perform further diagnosis of engine mechanical or engine control system. Refer EM and EC sections. Once resolved, perform battery test again.

4. STARTER MOTOR ACTIVATION

Check that the starter motor operates.

Does the starter motor turn?

YES >> Check ring gear and starter motor drive pinion. Once resolved, perform battery test again.

NO >> GO TO 7.

5. COMPARISON BETWEEN ENGINE COOLANT AND CRANKING VOLTAGE

Compare the engine coolant temperature and the cranking voltage with the specifications.

Minimum Specification of Cranking Voltage Referencing Coolant Temperature

Engine coolant temperature [°C (°F)]	Voltage [V]
-30 to -20 (-22 to -4)	8.6
-19 to -10 (-2 to 14)	9.1
-9 to 0 (16 to 32)	9.5
More than 1 (More than 34)	9.9

Is the voltage less than the specified value?

YES >> GO TO 7.

NO >> GO TO 6.

6. STARTER OPERATION

Check the starter operation status.

Does the starter motor turn smoothly?

YES >> Starter motor is OK. INSPECTION END

NO >> GO TO 7.

7. "B" TERMINAL CIRCUIT INSPECTION

Check "B" terminal circuit. Refer to [STR-16, "Diagnosis Procedure"](#).

Is "B" terminal circuit normal?

YES >> GO TO 8.

NO >> Repair as needed.

8. "S" CONNECTOR CIRCUIT INSPECTION

Check "S" connector circuit. Refer to [STR-17, "Diagnosis Procedure"](#).

A

STR

C

D

E

F

G

H

I

J

K

L

M

N

O

P

DIAGNOSIS AND REPAIR WORK FLOW

< BASIC INSPECTION >

Is "S" connector circuit normal?

- YES >> GO TO 9.
- NO >> Repair as needed.

9. ENGINE ROTATION STATUS

Check that the engine can be rotated by hand.

Does the engine turn freely by hand?

- YES >> Replace starter motor.
- NO >> Perform further diagnosis of engine mechanical or powertrain mechanism. Once resolved, perform battery test again using Multitasking battery and electrical diagnostic station GR8-1200 NI. Refer to the diagnostic station Instruction Manual for proper testing procedures.

Work Flow (Without GR8-1200 NI)

INFOID:000000010260567

OVERALL SEQUENCE

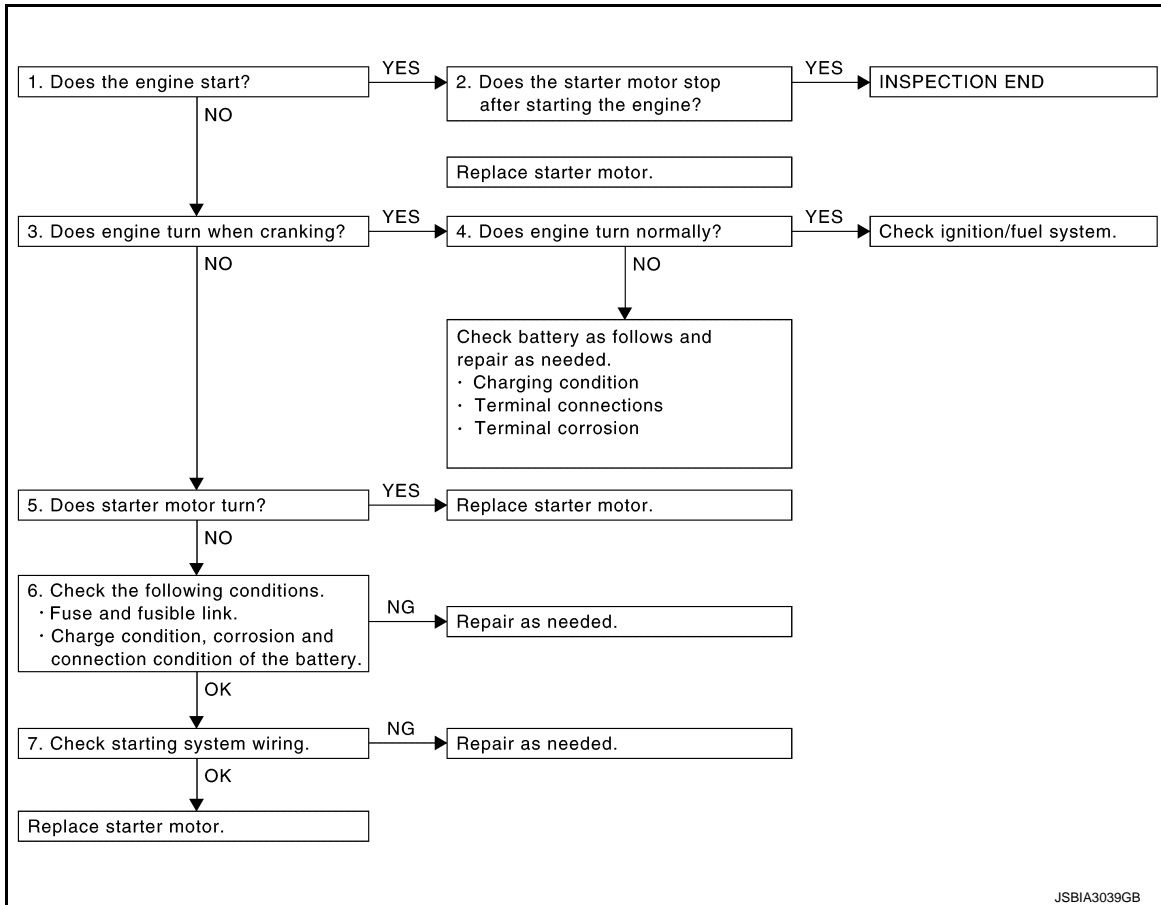

DETAILED FLOW

NOTE:

If any malfunction is found, immediately disconnect the battery cable from the negative terminal.

1. CHECK ENGINE START

Crank the engine and check that the engine starts.

Does the engine start?

- YES >> GO TO 2.
- NO >> GO TO 3.

2. CHECK THAT THE STARTER MOTOR STOPS

Check that the starter motor stops after starting the engine.

Does the starter motor stop?

- YES >> INSPECTION END

DIAGNOSIS AND REPAIR WORK FLOW

< BASIC INSPECTION >

NO >> Replace starter motor. Refer to [STR-20, "Removal and Installation"](#).

3.CHECK THAT THE ENGINE TURNS WHEN CRANKING

Check that the engine turns when cranking.

Does engine turn when cranking?

YES >> GO TO 4.

NO >> GO TO 5.

4.CHECK THE ENGINE SPEED WHEN CRANKING

Check that the engine speed is not low when cranking.

Does engine turn normally?

YES >> Check ignition/fuel system.

NO >> Check charge condition, corrosion and connection condition of the battery. Refer to [PG-133, "Work Flow"](#).

5.CHECK STARTER MOTOR ACTIVATION

Check that the starter motor runs at cranking.

Does starter motor turn?

YES >> Replace starter motor. Refer to [STR-20, "Removal and Installation"](#).

NO >> GO TO 6.

6.CHECK POWER SUPPLY CIRCUIT

Check the following conditions.

- Fuse and fusible link
- Charge condition, corrosion and connection condition of the battery. Refer to [PG-133, "Work Flow"](#).

Are these inspection results normal?

YES >> GO TO 7.

NO >> Repair as needed.

7.CHECK STARTING SYSTEM WIRING

Check the following.

- "B" terminal circuit. Refer to [STR-16, "Diagnosis Procedure"](#).
- "S" connector circuit. Refer to [STR-17, "Diagnosis Procedure"](#).

Are these inspection results normal?

YES >> Replace starter motor. Refer to [STR-20, "Removal and Installation"](#).

NO >> Repair as needed.

A

STR

C

D

E

F

G

H

I

J

K

L

M

N

O

P

B TERMINAL CIRCUIT

< DTC/CIRCUIT DIAGNOSIS >

DTC/CIRCUIT DIAGNOSIS

B TERMINAL CIRCUIT

Diagnosis Procedure

INFOID:0000000010260568

CAUTION:

Perform diagnosis under the condition that engine cannot start by the following procedure.

1. Remove fuel pump fuse.
2. Crank or start the engine (where possible) until the fuel pressure is released.

1. CHECK "B" TERMINAL CIRCUIT

1. Turn ignition switch OFF.
2. Check that starter motor "B" terminal connection is clean and tight.
3. Check voltage between starter motor "B" terminal and ground.

(+)		(-)	Voltage
Starter motor			
Connector	Terminal		
F57	2	Ground	Battery voltage

Is the inspection result normal?

YES >> GO TO 2.

NO >> Check harness between battery and starter motor for open circuit.

2. CHECK BATTERY CABLE CONNECTION STATUS (VOLTAGE DROP TEST)

1. Shift A/T selector lever to "P" or "N" position.
2. Check voltage between battery positive terminal and starter motor "B" terminal.

(+)	(-)		Condition	Voltage (V) (Approx.)
	Starter motor			
	Connector	Terminal		
Battery positive terminal	F57	2	When the ignition switch is in START position	Less than 0.5

Is the inspection result normal?

YES >> GO TO 3.

NO >> Check harness between the battery and the starter motor for poor continuity.

3. CHECK GROUND CIRCUIT STATUS (VOLTAGE DROP TEST)

1. Shift A/T selector lever to "P" or "N" position.
2. Check voltage between starter motor case and battery negative terminal.

(+)	(-)	Condition	Voltage (V) (Approx.)
Starter motor case	Battery negative terminal	When the ignition switch is in START position	Less than 0.2

Is the inspection result normal?

YES >> "B" terminal circuit is OK. Further inspection is necessary. Refer to [STR-11, "Work Flow \(With GR8-1200 NI\)"](#) or [STR-14, "Work Flow \(Without GR8-1200 NI\)"](#).

NO >> Check the starter motor case and ground for poor continuity.

S CONNECTOR CIRCUIT

< DTC/CIRCUIT DIAGNOSIS >

S CONNECTOR CIRCUIT

Diagnosis Procedure

INFOID:000000010260569

CAUTION:

Perform diagnosis under the condition that engine cannot start by the following procedure.

1. Remove fuel pump fuse.
2. Crank or start the engine (where possible) until the fuel pressure is released.

1. CHECK "S" CONNECTOR CIRCUIT

1. Turn ignition switch OFF.
2. Disconnect starter motor connector.
3. Shift A/T selector lever to "P" or "N" position.
4. Check voltage between starter motor harness connector and ground.

(+)		(-)	Condition	Voltage
Starter motor				
Connector	Terminal			
F55	1	Ground	When the ignition switch is in START position	Battery voltage

Is the inspection result normal?

YES >> "S" connector circuit is OK. Further inspection is necessary. Refer to [STR-11, "Work Flow \(With GR8-1200 NI\)"](#) or [STR-14, "Work Flow \(Without GR8-1200 NI\)"](#).

NO >> GO TO 2.

2. CHECK HARNESS CONTINUITY (OPEN CIRCUIT)

1. Turn ignition switch OFF.
2. Disconnect IPDM E/R harness connector.
3. Check continuity between starter motor harness connector and IPDM E/R harness connector.

Starter motor		IPDM E/R		Continuity
Connector	Terminal	Connector	Terminal	
F55	1	E10	3	Existed

Is the inspection result normal?

YES >> Further inspection is necessary. Refer to [SEC-50, "Work Flow"](#).

NO >> Repair the harness or connector.

A
STR
C
D
E
F
G
H
I
J
K
L
M
N
O
P

STARTING SYSTEM

< SYMPTOM DIAGNOSIS >

SYMPTOM DIAGNOSIS

STARTING SYSTEM

Symptom Table

INFOID:0000000010260570

Symptom	Reference
No normal cranking	Refer to STR-11. "Work Flow (With GR8-1200 NI)" or STR-14. "Work Flow (Without GR8-1200 NI)" .
Starter motor does not rotate	

STARTER MOTOR

< REMOVAL AND INSTALLATION >

REMOVAL AND INSTALLATION

STARTER MOTOR

Exploded View

INFOID:000000010260571

A

STR

REMOVAL

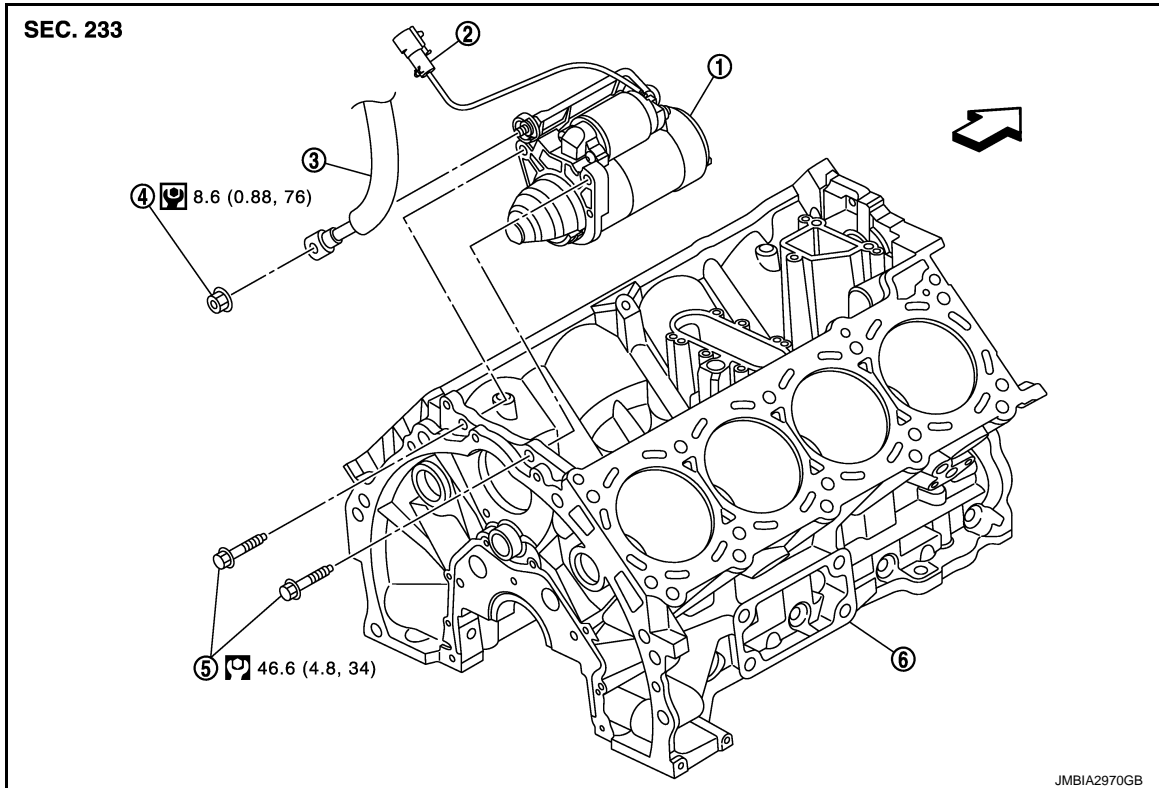



- 1. Starter motor
- 4. "B" terminal nut

- 2. "S" connector
- 5. Starter motor mounting bolt

- 3. "B" terminal harness
- 6. Cylinder block

← : Engine front

 : N-m (kg-m, ft-lb)

 : N-m (kg-m, in-lb)

DISASSEMBLY

C

D

E

F

G

H

I

J

K

L

M

N

O

P

STARTER MOTOR

< REMOVAL AND INSTALLATION >

Type: M001T30671

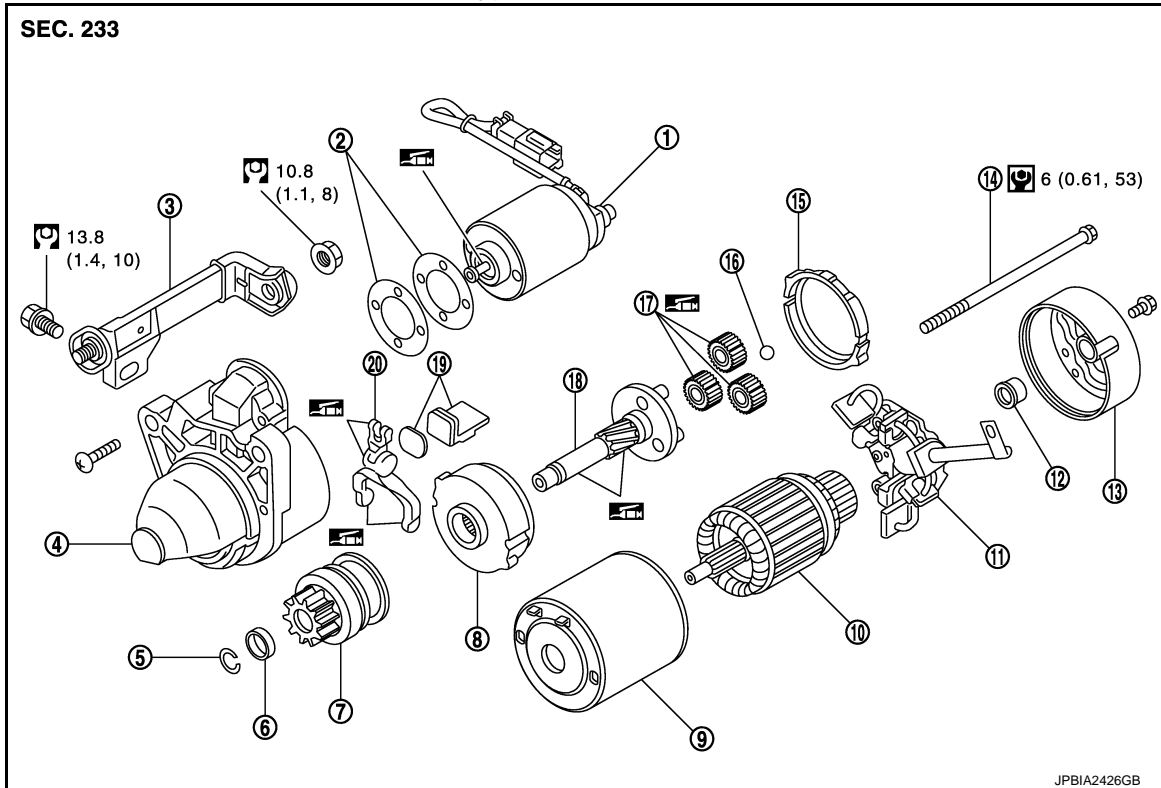

- | | | |
|-----------------------------|---------------------------|---------------------------|
| 1. Magnetic switch assembly | 2. Adjusting plate | 3. "B" terminal extension |
| 4. Gear case assembly | 5. Stopper ring | 6. Stopper |
| 7. Pinion assembly | 8. Internal gear | 9. Yoke assembly |
| 10. Armature assembly | 11. Brush holder assembly | 12. Metal RR |
| 13. Rear cover | 14. Through bolt | 15. Packing |
| 16. Ball | 17. Planetary gear | 18. Gear shaft |
| 19. Dust cover kit | 20. Shift lever | |

 : High-temperature grease point

 : N·m (kg-m, ft-lb)

 : N·m (kg-m, in-lb)

NOTE:

Apply high-temperature grease to lubricate the bearing, gears and frictional surface when assembling the starter.

Removal and Installation

INFOID:000000010260572

REMOVAL

1. Disconnect the battery cable from the negative terminal. Refer to [PG-141. "Removal and Installation"](#).
2. Remove engine cover. Refer to [EM-26. "Removal and Installation"](#).
3. Remove intake manifold. Refer to [EM-31. "Removal and Installation"](#).
4. Remove "B" terminal nut, and then "B" terminal harness.
5. Remove harness clip of "S" connector from heater pipe.
6. Disconnect "S" connector.
7. Remove starter motor mounting bolts.
8. Remove starter motor upward from the vehicle.

INSTALLATION

Note the following item, and then install in the reverse order of removal.

STARTER MOTOR

< REMOVAL AND INSTALLATION >

CAUTION:

Be careful to tighten "B" terminal nut to the specified torque.

A

STR

C

D

E

F

G

H

I

J

K

L

M

N

O

P

SERVICE DATA AND SPECIFICATIONS (SDS)

< SERVICE DATA AND SPECIFICATIONS (SDS)

SERVICE DATA AND SPECIFICATIONS (SDS)

SERVICE DATA AND SPECIFICATIONS (SDS)

Starter Motor

INFOID:0000000010260573

Type		M001T30671
		MITSUBISHI make
		Reduction gear type
System voltage		[V] 12
No-load	Terminal voltage	[V] 11
	Current	[A] Less than 120
	Revolution	[rpm] More than 3,220