

SECTION BR
BRAKE SYSTEM

A
B
C
D
E

CONTENTS

PRECAUTION	3	REAR DISC BRAKE	18
PRECAUTIONS	3	BRAKE PAD	18
Precaution for Supplemental Restraint System (SRS) "AIR BAG" and "SEAT BELT PRE-TENSIONER"	3	BRAKE PAD : Inspection and Adjustment	18
Precaution for Procedure without Cowl Top Cover.....	3	DISC ROTOR	18
Precaution for Brake system	3	DISC ROTOR : Inspection and Adjustment	18
Precautions for Removing of Battery Terminal	4	REMOVAL AND INSTALLATION	20
PREPARATION	5	BRAKE PEDAL	20
PREPARATION	5	Exploded View	20
Commercial Service Tools	5	Removal and Installation	20
SYMPTOM DIAGNOSIS	6	Inspection and Adjustment	21
NOISE, VIBRATION AND HARSHNESS (NVH) TROUBLESHOOTING	6	BRAKE PIPING	22
NVH Troubleshooting Chart	6	FRONT	22
PERIODIC MAINTENANCE	7	FRONT : Exploded View	22
BRAKE PEDAL	7	FRONT : Hydraulic Piping	23
Inspection and Adjustment	7	FRONT : Removal and Installation	23
BRAKE FLUID	10	FRONT : Inspection	24
Inspection	10	REAR	24
Draining	10	REAR : Exploded View	25
Refilling	11	REAR : Hydraulic Piping	25
Bleeding Brake System	11	REAR : Removal and Installation	26
HYDRAULIC BOOSTER ASSEMBLY	15	REAR : Inspection	26
Inspection	15	HYDRAULIC BOOSTER ASSEMBLY	28
FRONT DISC BRAKE	16	Exploded View	28
BRAKE PAD	16	Removal and Installation	29
BRAKE PAD : Inspection and Adjustment	16	Disassembly and Assembly	30
DISC ROTOR	16	Inspection and Adjustment	32
DISC ROTOR : Inspection and Adjustment	16	Disposal	33
		FRONT DISC BRAKE	34
		BRAKE PAD	34
		BRAKE PAD : Exploded View	34
		BRAKE PAD : Removal and Installation	34
		BRAKE PAD : Inspection	36

BR

G
H
I
J
K
L
M
N
O
P

BRAKE CALIPER ASSEMBLY	36	BRAKE CALIPER ASSEMBLY : Removal and Installation	43
BRAKE CALIPER ASSEMBLY : Exploded View ...	36	BRAKE CALIPER ASSEMBLY : Disassembly and Assembly	44
BRAKE CALIPER ASSEMBLY : Removal and Installation	37	BRAKE CALIPER ASSEMBLY : Inspection	45
BRAKE CALIPER ASSEMBLY : Disassembly and Assembly	38		
BRAKE CALIPER ASSEMBLY : Inspection	39		
REAR DISC BRAKE	41		
BRAKE PAD	41	SERVICE DATA AND SPECIFICATIONS (SDS)	47
BRAKE PAD : Exploded View	41	SERVICE DATA AND SPECIFICATIONS (SDS)	47
BRAKE PAD : Removal and Installation	41	General Specification	47
BRAKE PAD : Inspection	42	Brake Pedal	47
BRAKE CALIPER ASSEMBLY	42	Brake Booster	47
BRAKE CALIPER ASSEMBLY : Exploded View ...	42	Front Disc Brake	47
		Rear Disc Brake	47

PRECAUTIONS

< PRECAUTION >

PRECAUTION

PRECAUTIONS

Precaution for Supplemental Restraint System (SRS) "AIR BAG" and "SEAT BELT PRE-TENSIONER"

INFOID:000000009010878

The Supplemental Restraint System such as "AIR BAG" and "SEAT BELT PRE-TENSIONER", used along with a front seat belt, helps to reduce the risk or severity of injury to the driver and front passenger for certain types of collision. Information necessary to service the system safely is included in the "SRS AIR BAG" and "SEAT BELT" of this Service Manual.

WARNING:

Always observe the following items for preventing accidental activation.

- To avoid rendering the SRS inoperative, which could increase the risk of personal injury or death in the event of a collision that would result in air bag inflation, all maintenance must be performed by an authorized NISSAN/INFINITI dealer.
- Improper maintenance, including incorrect removal and installation of the SRS, can lead to personal injury caused by unintentional activation of the system. For removal of Spiral Cable and Air Bag Module, see "SRS AIR BAG".
- Never use electrical test equipment on any circuit related to the SRS unless instructed to in this Service Manual. SRS wiring harnesses can be identified by yellow and/or orange harnesses or harness connectors.

PRECAUTIONS WHEN USING POWER TOOLS (AIR OR ELECTRIC) AND HAMMERS

WARNING:

Always observe the following items for preventing accidental activation.

- When working near the Air Bag Diagnosis Sensor Unit or other Air Bag System sensors with the ignition ON or engine running, never use air or electric power tools or strike near the sensor(s) with a hammer. Heavy vibration could activate the sensor(s) and deploy the air bag(s), possibly causing serious injury.
- When using air or electric power tools or hammers, always switch the ignition OFF, disconnect the battery, and wait at least 3 minutes before performing any service.

Precaution for Procedure without Cowl Top Cover

INFOID:000000009010879

When performing the procedure after removing cowl top cover, cover the lower end of windshield with urethane, etc to prevent damage to windshield.

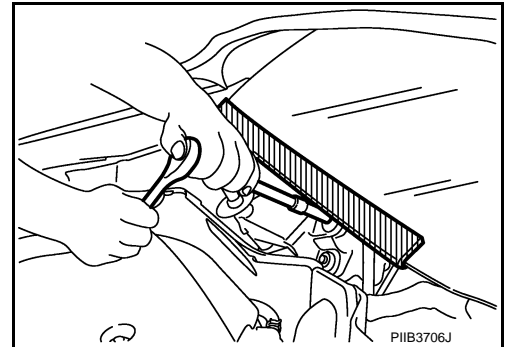

Precaution for Brake system

INFOID:000000009010880

WARNING:

Since dust covering the front and rear brakes has an affect on human body, the dust must be removed with a dust collector. Never splatter the dust with an air blow gun.

- Brake fluid use refer to [MA-15, "FOR NORTH AMERICA : Fluids and Lubricants"](#) (for North America), [MA-16, "FOR MEXICO : Fluids and Lubricants"](#) (for Mexico).
- Never reuse drained brake fluid.
- Never spill or splash brake fluid on painted surfaces. Brake fluid may seriously damage paint. Wipe it off immediately and wash with water if it gets on a painted surface.
- Always confirm the specified tightening torque when installing the brake pipes.
- After pressing the brake pedal more deeply or harder than normal driving, such as air bleeding, check each item of brake pedal. Adjust brake pedal if it is outside the standard value.

PRECAUTIONS

< PRECAUTION >

- Always clean with new brake fluid when cleaning the brake caliper and other components.
- Never use mineral oils such as gasoline or light oil to clean. They may damage rubber parts and cause improper operation.
- Always loosen the brake tube flare nut with a flare nut wrench.
- Tighten the brake tube flare nut to the specified torque with a crow-foot (A) and torque wrench (B).
- Brake system is an important safety part. If a brake fluid leak is detected, always disassemble the affected part. If a malfunction is detected, replace part with a new one.
- Always connect the battery terminals when moving the vehicle.
- Turn the ignition switch OFF and disconnect the hydraulic booster assembly harness connector or the battery negative terminal before performing the work.
- Check that no brake fluid leakage is present after replacing the parts.
- Burnish the brake contact surfaces after refinishing or replacing rotors, after replacing pads, or if a soft pedal occurs at very low mileage.
- Front brake pad: Refer to [BR-16, "BRAKE PAD : Inspection and Adjustment"](#).
- Front disc rotor: Refer to [BR-16, "DISC ROTOR : Inspection and Adjustment"](#).
- Rear brake pad: Refer to [BR-18, "BRAKE PAD : Inspection and Adjustment"](#).
- Rear disc rotor: Refer to [BR-18, "DISC ROTOR : Inspection and Adjustment"](#).

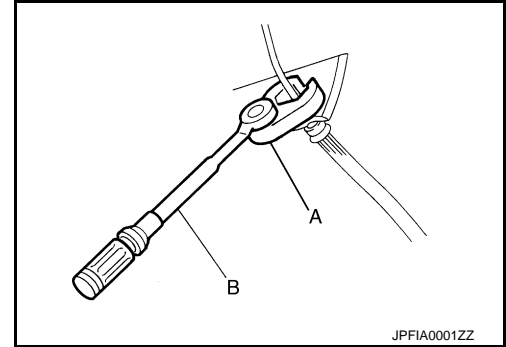

Precautions for Removing of Battery Terminal

INFOID:000000009864461

- When removing the 12V battery terminal, turn OFF the ignition switch and wait at least 30 seconds.

NOTE:

ECU may be active for several tens of seconds after the ignition switch is turned OFF. If the battery terminal is removed before ECU stops, then a DTC detection error or ECU data corruption may occur.

- For vehicles with the 2-batteries, be sure to connect the main battery and the sub battery before turning ON the ignition switch.

NOTE:

If the ignition switch is turned ON with any one of the terminals of main battery and sub battery disconnected, then DTC may be detected.

- After installing the 12V battery, always check "Self Diagnosis Result" of all ECUs and erase DTC.

NOTE:

The removal of 12V battery may cause a DTC detection error.

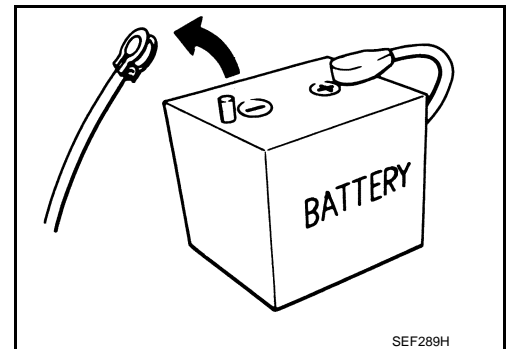

PREPARATION

< PREPARATION >

PREPARATION

PREPARATION

Commercial Service Tools

INFOID:000000009010881

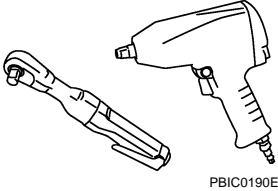
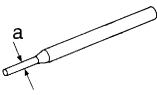
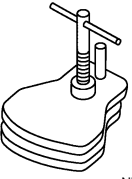
Tool name	Description
<p>Power tool</p>  <p>PBIC0190E</p>	<p>Loosening bolts and nuts</p>
<p>Pin punch a: 4 mm (0.16 in)</p>  <p>NT410</p>	<p>Removing and installing reservoir tank</p>
<p>Brake caliper wrench</p>  <p>NNFIA0040ZZ</p>	<p>Return the piston</p>

A
B
C
D
E
BR
G
H
I
J
K
L
M
N
O
P

NOISE, VIBRATION AND HARSHNESS (NVH) TROUBLESHOOTING

< SYMPTOM DIAGNOSIS >

SYMPTOM DIAGNOSIS

NOISE, VIBRATION AND HARSHNESS (NVH) TROUBLESHOOTING

NVH Troubleshooting Chart

INFOID:000000009010882

Use the chart below to find the cause of the symptom. If necessary, repair or replace these parts.

Symptom		BRAKE	Possible cause and SUSPECTED PARTS																						
			Pads damaged	Pads uneven wear	Shims damaged	Rotor imbalance	Rotor damage	Rotor runout	Rotor deformation	Rotor deflection	Rotor rust	Rotor thickness variation	Drum out of round	PROPELLER SHAFT	DIFFERENTIAL	AXLE AND SUSPENSION	TIRE	ROAD WHEEL	DRIVE SHAFT	STEERING					
Noise	BRAKE	Noise	x	x	x																				
		Shake				x								x			x	x	x	x	x				
		Shimmy, Judder				x	x	x	x	x	x	x					x	x	x						x
Reference page			BR-16, BR-18	BR-16, BR-18	BR-36, BR-42	BR-16, BR-18	BR-16, BR-18	BR-16, BR-18	BR-16, BR-18	BR-16, BR-18	BR-16, BR-18	BR-16, BR-18	BR-16, BR-18	BR-16, BR-18	BR-16, BR-18	BR-16, BR-18	BR-16, BR-18	BR-16, BR-18	BR-16, BR-18	BR-16, BR-18	BR-16, BR-18	BR-16, BR-18	BR-16, BR-18	BR-16, BR-18	

x: Applicable

BRAKE PEDAL

< PERIODIC MAINTENANCE >

PERIODIC MAINTENANCE

BRAKE PEDAL

Inspection and Adjustment

INFOID:000000009010883

INSPECTION

Brake Pedal Height

Check the brake pedal height (H_1) between the dash lower panel (1) and the brake pedal upper surface.

H_1 : Refer to [BR-47, "Brake Pedal"](#).

CAUTION:

Perform it with the floor trim removed.

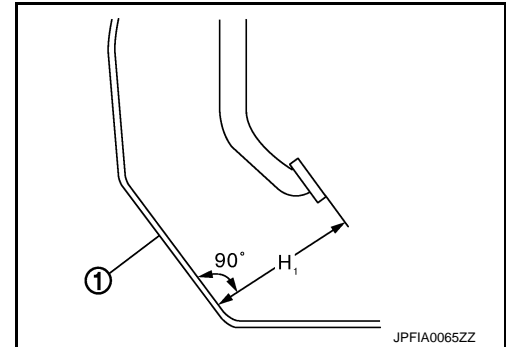

Stop Lamp Switch and Brake Switch

Check the clearance (C) between the brake pedal bracket (1) and the stop lamp switch and brake switch (2) threaded end.

C : Refer to [BR-47, "Brake Pedal"](#).

CAUTION:

The stop lamp must turn off when the brake pedal is released.

NOTE:

Pull the brake pedal pad to make the clearance between the stop lamp switch and brake switch threaded end and the brake pedal bracket.

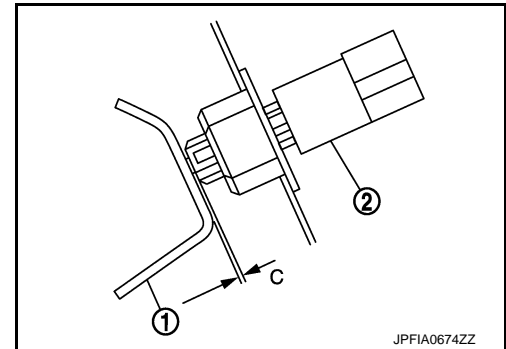

Brake Pedal Play

Press the brake pedal. Check the brake pedal play (A) (stroke until fluid pressure occurs).

A : Refer to [BR-47, "Brake Pedal"](#).

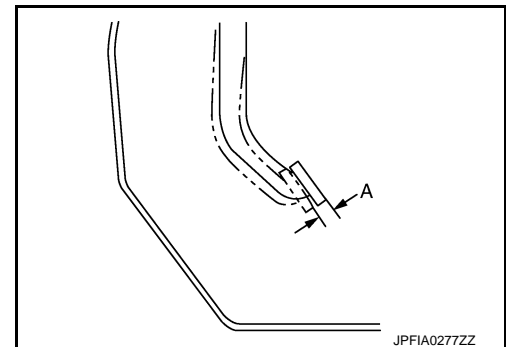

Depressed Brake Pedal Height

Check the height between the dash lower panel (1) and the top face of the brake pedal (H_2) when depressing the brake pedal with a force of 490 N (50 kg, 110 lb) while the engine is running.

H_2 : Refer to [BR-47, "Brake Pedal"](#).

CAUTION:

Perform it with the floor trim removed.

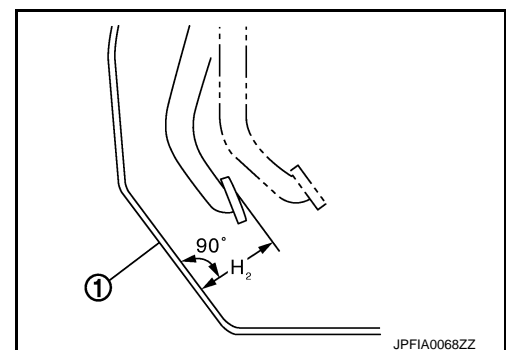

ADJUSTMENT

A
B
C
D
E
BR
G
H
I
J
K
L
M
N
O
P

BRAKE PEDAL

< PERIODIC MAINTENANCE >

Brake Pedal Height

1. Remove instrument lower panel LH. Refer to [IP-14, "Removal and Installation"](#).
2. Disconnect the stop lamp switch harness connector and the brake switch harness connector.
3. Loosen the stop lamp switch and brake switch by turning it 45° counterclockwise.
4. Loosen the input rod lock nut (1).
5. Rotate the input rod (2), and adjust the brake pedal to the specified height.

CAUTION:

- Perform it with the floor trim removed.
- The threaded end of the input rod must project to the inner side of the clevis (3).

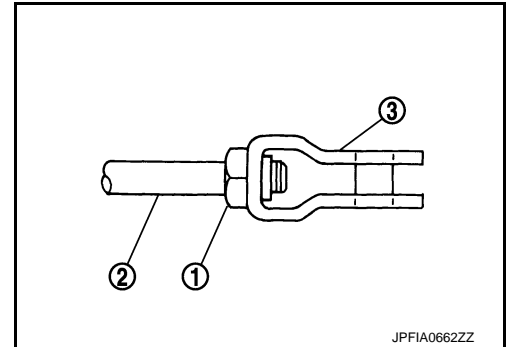

H₁ : Refer to [BR-47, "Brake Pedal"](#).

6. Tighten the lock nut. Refer to [BR-28, "Exploded View"](#).
7. Adjust the clearance between the brake pedal bracket and the stop lamp switch and brake switch threaded end after adjusting the brake pedal height.

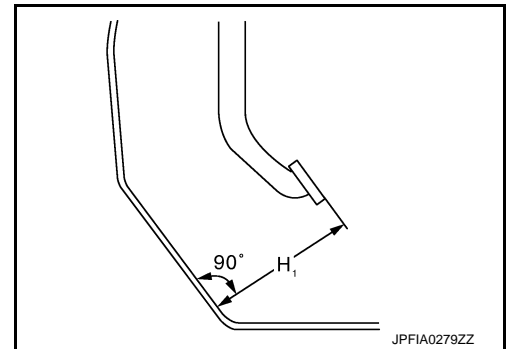

Stop Lamp Switch and Brake Switch

1. Remove instrument lower panel LH. Refer to [IP-14, "Removal and Installation"](#).
2. Disconnect the stop lamp switch harness connector and the brake switch harness connector.
3. Loosen the stop lamp switch and brake switch by turning it 45° counterclockwise.
4. Press-fit the stop lamp switch and brake switch (2) until the stop lamp switch and brake switch hits the brake pedal bracket (1) 45° clockwise while pulling the brake pedal pad slightly.

CAUTION:

- The clearance (C) between the brake pedal bracket and stop lamp switch and brake switch threaded end must be the specified value.

C : Refer to [BR-47, "Brake Pedal"](#).

- The stop lamp must turn off when the brake pedal is released.

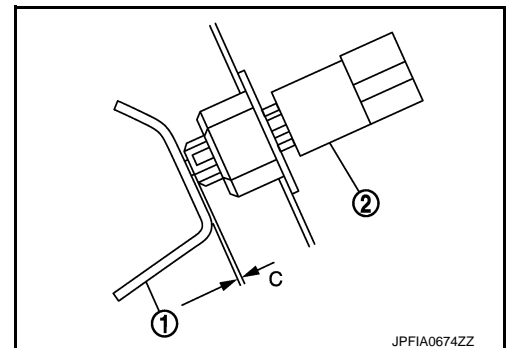

Brake Pedal Play

1. Remove instrument lower panel LH. Refer to [IP-14, "Removal and Installation"](#).
2. Disconnect the stop lamp switch harness connector and the brake switch harness connector.
3. Loosen the stop lamp switch and brake switch by turning it 45° counterclockwise.

BRAKE PEDAL

< PERIODIC MAINTENANCE >

4. Press-fit the stop lamp switch and brake switch (2) until the stop lamp switch and brake switch hits the brake pedal bracket (1) 45° clockwise while pulling the brake pedal pad slightly.

CAUTION:

- The clearance (C) between the brake pedal bracket and stop lamp switch and brake switch threaded end must be the specified value.

C : Refer to [BR-47, "Brake Pedal"](#).

- The stop lamp must turn off when the brake pedal is released.

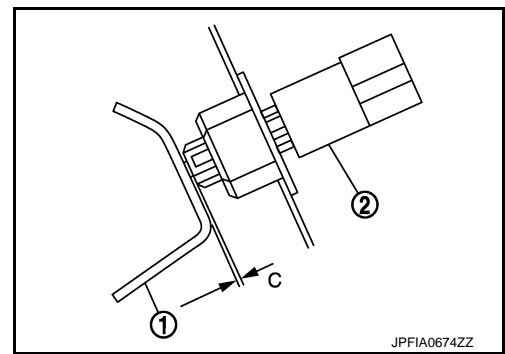

Depressed Brake Pedal Height

1. Perform the air bleeding. Refer to [BR-11, "Bleeding Brake System"](#).
2. Check the height between the dash lower panel (1) and the top face of the brake pedal (H₂) when depressing the brake pedal with a force of 490 N (50 kg, 110 lb) while the engine is running.

H₂ : Refer to [BR-47, "Brake Pedal"](#).

CAUTION:

Perform it with the floor trim removed.

3. Adjust the brake pedal play after adjusting the brake pedal height, clearance between the brake pedal bracket and the stop lamp switch and brake switch threaded end.

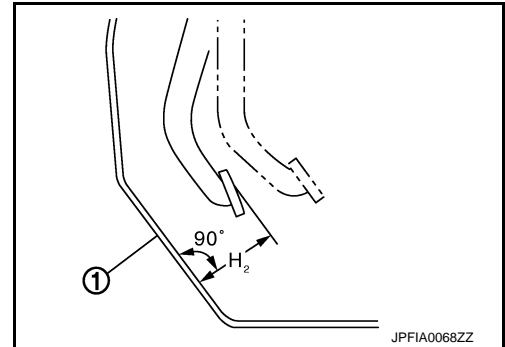

A
B
C
D
E
BR
G
H
I
J
K
L
M
N
O
P

BRAKE FLUID

< PERIODIC MAINTENANCE >

BRAKE FLUID

Inspection

INFOID:000000009010884

BRAKE FLUID LEVEL

- Check that the fluid level in the reservoir tank is within the specified range (MAX – MIN lines).

CAUTION:

Turn OFF the ignition switch and depress the brake pedal 20 times or more to check brake fluid level.

NOTE:

Since brake fluid is in the accumulator in pressurized condition, the reservoir tank brake fluid level should be lower than the MAX line.

- Visually check for any brake fluid leakage around the reservoir tank.
- Check the brake system for any leakage if the fluid level is extremely low (lower than MIN).
- Check the brake system for fluid leakage if the warning lamp remains illuminated even after the parking brake is released.
- Check the reservoir tank for the mixing of foreign matter (e.g. dust) and oils other than brake fluid.

BRAKE LINE

1. Check brake line (tubes and hoses) for cracks, deterioration or other damage. Replace any damaged parts.
2. Depress the brake pedal with a force of 490 N (50 kg, 110 lb) and hold down the pedal for approx. 5 seconds with the engine running. Check for any fluid leakage.

CAUTION:

Retighten the applicable connection to the specified torque and repair any abnormal (damaged, worn or deformed) part if any brake fluid leakage is present.

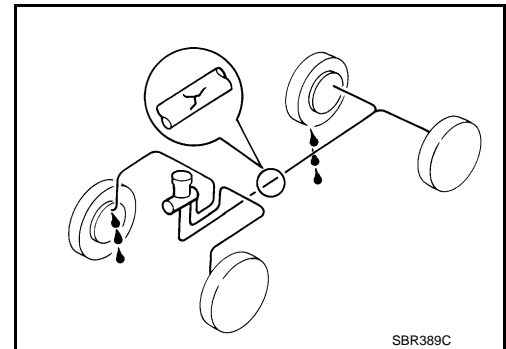

Draining

INFOID:000000009010885

FRONT BRAKE

CAUTION:

- If the brake fluid adheres to the brake caliper assembly and disc rotor, quickly wipe it off.
- Never spill or splash brake fluid on painted surfaces. Brake fluid may seriously damage paint. Wipe it off immediately and wash with water if it gets on a painted surface.
- Never operate the brake pedal with the reservoir cap removed. Failure to do this may cause the scattering of brake fluid.
- Never operate the brake pedal excessively during the work procedure.

1. Turn the ignition switch ON.
2. Connect a vinyl tube to the bleed valve.
3. Depress the brake pedal and loosen the bleeder valve.
4. Depress the brake pedal several time gradually discharge brake fluid.

REAR BRAKE

CAUTION:

- If the brake fluid adheres to the brake caliper assembly and disc rotor, quickly wipe it off.
- Never spill or splash brake fluid on painted surfaces. Brake fluid may seriously damage paint. Wipe it off immediately and wash with water if it gets on a painted surface.
- Never operate the brake pedal with the reservoir cap removed. Failure to do this may cause the scattering of brake fluid.
- Never operate the brake pedal excessively during the work procedure.

1. Turn the ignition switch ON.
2. Connect a vinyl tube to the bleed valve.
3. Depress the brake pedal and loosen the bleeder valve to gradually discharge brake fluid.

BRAKE FLUID

< PERIODIC MAINTENANCE >

NOTE:

Since brake fluid is conveyed by the motor, the brake pedal is not necessarily depressed.

Refilling

INFOID:000000009010886

FRONT BRAKE

CAUTION:

- If the brake fluid adheres to the brake caliper assembly and disc rotor, quickly wipe it off.
- Never spill or splash brake fluid on painted surfaces. Brake fluid may seriously damage paint. Wipe it off immediately and wash with water if it gets on a painted surface.
- Never operate the brake pedal with the reservoir cap removed. Failure to do this may cause the scattering of brake fluid.
- Never operate the brake pedal excessively during the work procedure.
- Monitor the fluid level in the reservoir tank while performing the refilling.

1. Check that there is no foreign material in the reservoir tank, and refill with new brake fluid.

CAUTION:

- Never reuse drained brake fluid.
- Never allow oils other than brake fluid to enter the reservoir tank.

2. Turn the ignition switch ON.
3. Connect a vinyl tube to the bleed valve.
4. Depress the brake pedal and loosen the bleeder valve.
5. Depress the brake pedal several times until the refilled brake fluid is discharged and tighten the air bleeder to the specified torque with the brake pedal depressed. Refer to [BR-36, "BRAKE CALIPER ASSEMBLY : Exploded View"](#).
6. Perform the air bleeding. Refer to [BR-11, "Bleeding Brake System"](#).

REAR BRAKE

CAUTION:

- If the brake fluid adheres to the brake caliper assembly and disc rotor, quickly wipe it off.
- Never spill or splash brake fluid on painted surfaces. Brake fluid may seriously damage paint. Wipe it off immediately and wash with water if it gets on a painted surface.
- Never operate the brake pedal with the reservoir cap removed. Failure to do this may cause the scattering of brake fluid.
- Never operate the brake pedal excessively during the work procedure.
- Monitor the fluid level in the reservoir tank while performing the refilling.

1. Check that there is no foreign material in the reservoir tank, and refill with new brake fluid.

CAUTION:

- Never reuse drained brake fluid.
- Never allow oils other than brake fluid to enter the reservoir tank.

2. Turn the ignition switch ON.
3. Connect a vinyl tube to the bleed valve.
4. Depress the brake pedal and loosen the bleeder valve.
5. Depress the brake pedal several times until the refilled brake fluid is discharged and tighten the air bleeder to the specified torque with the brake pedal depressed. Refer to [BR-42, "BRAKE CALIPER ASSEMBLY : Exploded View"](#).

NOTE:

Since brake fluid is conveyed by the motor, the brake pedal is not necessarily depressed.

6. Perform the air bleeding. Refer to [BR-11, "Bleeding Brake System"](#).

Bleeding Brake System

INFOID:000000009010887

CAUTION:

- Bleed air in the following order: motor/accumulator assembly → front right brake → front left brake → rear left brake → and rear right brake.
- The VDC warning lamp, ABS warning lamp and brake warning lamp turn ON and DTC "C118E" may be detected in self-diagnosis result for "ABS" with CONSULT when the brake pedal is excessively operated, such as air bleeding. This is not a system malfunction because this occurs due to the temporary decrease in accumulator fluid pressure. The system returns to normal condition when the accumulator fluid pressure reaches the specified pressure with the ignition switch ON and the VDC

BRAKE FLUID

< PERIODIC MAINTENANCE >

warning lamp, ABS warning lamp, and brake warning lamp turn OFF. After these steps, erase self-diagnosis results for "ABS" with CONSULT.

- DTC other than "C118E" is detected: Refer to [BRC-50, "DTC Index"](#).

NOTE:

When the ignition switch is ON, the brake warning lamp may turn ON even when the parking brake pedal is released with the brake fluid within the specified level. This indicates the decrease in accumulator fluid pressure.

MOTOR/ACCUMULATOR ASSEMBLY

CAUTION:

- If the brake fluid adheres to the brake caliper assembly and disc rotor, quickly wipe it off.
- Never spill or splash brake fluid on painted surfaces. Brake fluid may seriously damage paint. Wipe it off immediately and wash with water if it gets on a painted surface.
- Never operate the brake pedal with the reservoir cap removed. Failure to do this may cause the scattering of brake fluid.
- Never operate the brake pedal excessively during the work procedure.
- Monitor the fluid level in the reservoir tank while performing the air bleeding.
- Bleed air in the following order: motor/accumulator assembly → front right brake → front left brake → rear left brake → and rear right brake.

1. Turn the ignition switch OFF.
2. Depress the brake pedal 20 times or more.
3. Check that there is no foreign material in the reservoir tank, and refill with new brake fluid.

CAUTION:

- Never reuse drained brake fluid.
- Never allow oils other than brake fluid to enter the reservoir tank.

4. Turn the ignition switch ON.

NOTE:

The motor is activated and automatically stops.

5. Turn the ignition switch OFF.

6. Depress the brake pedal 20 times or more.

NOTE:

The pressure loss in the accumulator results in a large brake pedal stroke. In addition to this, the brake pedal depression becomes lighter in initial stage.

7. Repeat steps 4 to 6 for 5 times.
8. Turn the ignition switch ON to check that the time between motor activation and automatic stop is less than 18 seconds. If the time is 18 seconds or more, repeat from Step 4 to 8.

FRONT BRAKE

CAUTION:

- If the brake fluid adheres to the brake caliper assembly and disc rotor, quickly wipe it off.
- Never spill or splash brake fluid on painted surfaces. Brake fluid may seriously damage paint. Wipe it off immediately and wash with water if it gets on a painted surface.
- Never operate the brake pedal with the reservoir cap removed. Failure to do this may cause the scattering of brake fluid.
- Never operate the brake pedal excessively during the work procedure.
- Monitor the fluid level in the reservoir tank while performing the air bleeding.
- Bleed air in the following order: motor/accumulator assembly → front right brake → front left brake → rear left brake → and rear right brake.

1. Turn the ignition switch OFF.
2. Depress the brake pedal 20 times or more.

NOTE:

The pressure loss in the accumulator results in a large brake pedal stroke. In addition to this, the brake pedal depression becomes lighter in initial stage.

3. Check that there is no foreign material in the reservoir tank, and refill with new brake fluid.

CAUTION:

- Never reuse drained brake fluid.
- Never allow oils other than brake fluid to enter the reservoir tank.

4. Turn the ignition switch ON.

BRAKE FLUID

< PERIODIC MAINTENANCE >

5. Connect a vinyl tube to the bleed valve.
6. Depress the brake pedal and loosen the bleeder valve.
7. Repeat steps 1 to 6 until all of the air is out of the brake line and tighten the air bleeder to the specified torque with the brake pedal depressed. Refer to [BR-36, "BRAKE CALIPER ASSEMBLY : Exploded View"](#).
8. Check that no drag feel is present for the front disc brake. Refer to [BR-39, "BRAKE CALIPER ASSEMBLY : Inspection"](#).
9. Check each item of brake pedal. Adjust it if the measurement value is not the standard. Refer to [BR-7, "Inspection and Adjustment"](#).

REAR BRAKE

CAUTION:

- If the brake fluid adheres to the brake caliper assembly and disc rotor, quickly wipe it off.
- Never spill or splash brake fluid on painted surfaces. Brake fluid may seriously damage paint. Wipe it off immediately and wash with water if it gets on a painted surface.
- Never operate the brake pedal with the reservoir cap removed. Failure to do this may cause the scattering of brake fluid.
- Never operate the brake pedal excessively during the work procedure.
- Monitor the fluid level in the reservoir tank while performing the air bleeding.
- Bleed air in the following order: motor/accumulator assembly → front right brake → front left brake → rear left brake → and rear right brake.

1. Turn the ignition switch OFF.
2. Depress the brake pedal 20 times or more.

NOTE:

The pressure loss in the accumulator results in a large brake pedal stroke. In addition to this, the brake pedal depression becomes lighter in initial stage.

3. Check that there is no foreign material in the reservoir tank, and refill with new brake fluid.

CAUTION:

- Never reuse drained brake fluid.
- Never allow oils other than brake fluid to enter the reservoir tank.

4. Turn the ignition switch ON.
5. Connect a vinyl tube to the bleed valve.
6. Depress the brake pedal and loosen the bleeder valve.
7. Depress and hold the brake pedal depression to discharge 100 cc of brake fluid before tightening the air bleeder to the specified torque. Refer to [BR-42, "BRAKE CALIPER ASSEMBLY : Exploded View"](#).
- NOTE:
Since brake fluid is conveyed by the motor, the brake pedal is not necessarily depressed.
8. Release the brake pedal.
9. Repeat steps 1 to 8 until all of the air is out of the brake line and tighten the air bleeder to the specified torque with the brake pedal depressed. Refer to [BR-42, "BRAKE CALIPER ASSEMBLY : Exploded View"](#).
10. Check that no drag feel is present for the rear disc brake. Refer to [BR-45, "BRAKE CALIPER ASSEMBLY : Inspection"](#).
11. Check each item of brake pedal. Adjust it if the measurement value is not the standard. Refer to [BR-7, "Inspection and Adjustment"](#).

BRAKE FLUID LEVEL ADJUSTMENT AFTER AIR BLEEDING

1. Turn the ignition switch OFF.
2. Depress the brake pedal 20 times or more.

NOTE:

The pressure loss in the accumulator results in a large brake pedal stroke. In addition to this, the brake pedal depression becomes lighter in initial stage.

BRAKE FLUID

< PERIODIC MAINTENANCE >

3. Adjust brake fluid level to the reservoir tank MAX line.
CAUTION:
Never adjust with the ignition switch ON.
4. Turn the ignition switch ON.
5. Check that the reservoir tank brake fluid level is 4 – 12 mm (0.16 – 0.47 in) lower than the MAX line.

NOTE:

Since brake fluid is in the accumulator in pressurized condition, the reservoir tank brake fluid level should be lower than the MAX line.

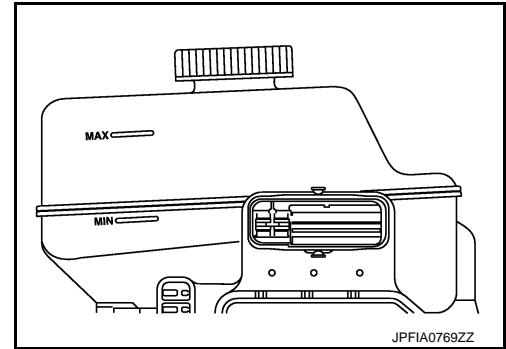

HYDRAULIC BOOSTER ASSEMBLY

< PERIODIC MAINTENANCE >

HYDRAULIC BOOSTER ASSEMBLY

Inspection

INFOID:000000009010888

OPERATION CHECK

1. Turn the ignition switch OFF.
2. Depress the brake pedal 20 times or more.

NOTE:

The pressure loss in the accumulator results in a large brake pedal stroke. In addition to this, the brake pedal depression becomes lighter in initial stage.

3. Check that the fluid level in the reservoir tank is MAX line.
4. Position the selector lever in P range to release the parking brake.
5. Turn the ignition switch ON to check the time between motor activation and motor stop.

Motor operating time : 18 seconds or less

6. After the motor is stopped, check that the ABS warning lamp and the VDC warning lamp in the combination meter are OFF when the engine is started.
7. Stop the engine (ignition switch OFF).
8. Turn the ignition switch ON and depress the brake pedal 4 to 5 times to check the time between motor activation and motor stop.

Motor operating time : 2 – 11 seconds

9. Turn the ignition switch OFF. Turn the ignition switch ON again. Check that the VDC warning lamp turns ON when the brake pedal is depressed 15 to 20 times.
10. Check that the VDC warning lamp turns ON when the brake pedal is depressed 15 to 20 times after the lapse of 120 seconds or more after the ignition switch is turned ON again.
11. Perform the self-diagnosis for “ABS” with CONSULT and erase self-diagnosis results.

FUNCTION CHECK

1. Turn the ignition switch OFF.
2. Depress the brake pedal 20 times or more.

NOTE:

The pressure loss in the accumulator results in a large brake pedal stroke. In addition to this, the brake pedal depression becomes lighter in initial stage.

3. Turn the ignition switch ON with the brake pedal depressed to check that the clearance between the brake pedal and the dash lower panel decreases.

A
B
C
D
E
BR
G
H
I
J
K
L
M
N
O
P

FRONT DISC BRAKE

< PERIODIC MAINTENANCE >

FRONT DISC BRAKE

BRAKE PAD

BRAKE PAD : Inspection and Adjustment

INFOID:000000009010889

INSPECTION

Check the thickness of brake pad from the inspection hole (A) on brake caliper assembly. Check use a scale if necessary.

Wear thickness : Refer to [BR-47, "Front Disc Brake"](#).

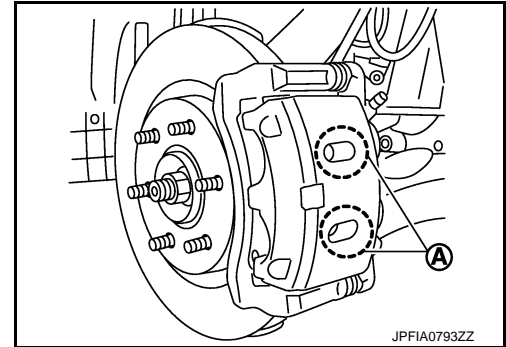

ADJUSTMENT

CAUTION:

- Burnish contact surfaces between pads according to the following procedure after refinishing or replacing brake pads, or if a soft pedal occurs at very low mileage.
- Be careful of vehicle speed because the brake does not operate firmly/securely until pads and disc rotor are securely fitted.
- Only perform this procedure under safe road and traffic conditions. Use extreme caution.

1. Drive vehicle on straight, flat road.
2. Depress brake pedal with the power to stop vehicle within 3 to 5 seconds until the vehicle stops.
3. Drive without depressing brake for a few minutes to cool the brake.
4. Repeat steps 1 to 3 until pad and disc rotor are securely fitted.

DISC ROTOR

DISC ROTOR : Inspection and Adjustment

INFOID:000000009010890

INSPECTION

Appearance

Check surface of disc rotor for uneven wear, cracks, and serious damage. Replace it if necessary. Refer to [FAX-7, "Removal and Installation"](#) (2WD), [FAX-17, "Removal and Installation"](#) (4WD).

Runout

1. Fix the disc rotor to the wheel hub and bearing assembly with wheel nuts (2 points at least).
2. Check the wheel bearing axial end play before the inspection. Refer to [FAX-6, "Inspection"](#) (2WD), [FAX-15, "Inspection"](#) (4WD).
3. Inspect the runout with a dial indicator to measure at 10 mm (0.39 in) inside the disc edge.

Runout : Refer to [BR-47, "Front Disc Brake"](#).

4. Find the installation position that has a minimum runout by shifting the disc rotor-to-wheel hub and bearing assembly installation position by one hole at a time if the runout exceeds the limit value.
5. Refinish the disc rotor if the runout is outside the limit even after performing the above operation. [When refinishing, use the Pro-Cut PEM On-Car brake Lathe (Tool No. 38-PFM90.5) or equivalent.]

CAUTION:

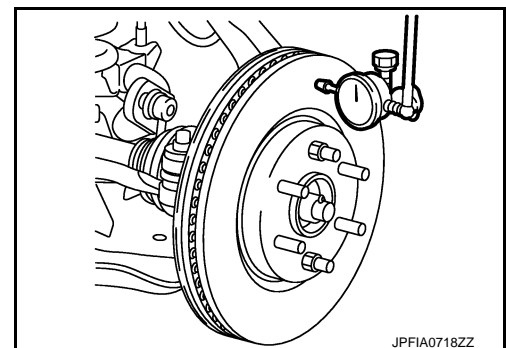

FRONT DISC BRAKE

< PERIODIC MAINTENANCE >

- Check in advance that the thickness of the disc rotor is wear thickness + 0.3 mm (0.012 in) or more.
- If the thickness is less than wear thickness + 0.3 mm (0.012 in), replace the disc rotor. Refer to [FAX-7, "Removal and Installation"](#) (2WD), [FAX-17, "Removal and Installation"](#) (4WD).

Wear thickness : Refer to [BR-47, "Front Disc Brake"](#).

Thickness

Check the thickness of the disc rotor using a micrometer. Replace the disc rotor if the thickness is below the wear limit. Refer to [FAX-7, "Removal and Installation"](#) (2WD), [FAX-17, "Removal and Installation"](#) (4WD).

Wear thickness : Refer to [BR-47, "Front Disc Brake"](#).

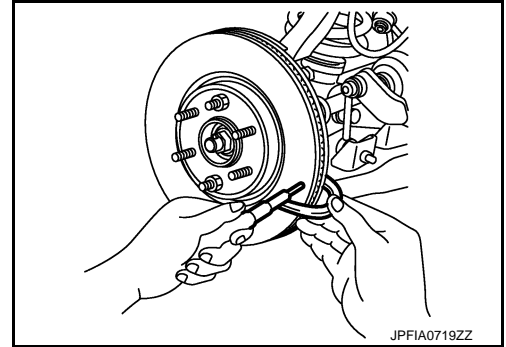

ADJUSTMENT

CAUTION:

- Burnish contact surfaces between pads according to the following procedure after refinishing or replacing brake pads, or if a soft pedal occurs at very low mileage.
 - Be careful of vehicle speed because the brake does not operate firmly/securely until pads and disc rotor are securely fitted.
 - Only perform this procedure under safe road and traffic conditions. Use extreme caution.
1. Drive vehicle on straight, flat road.
 2. Depress brake pedal with the power to stop vehicle within 3 to 5 seconds until the vehicle stops.
 3. Drive without depressing brake for a few minutes to cool the brake.
 4. Repeat steps 1 to 3 until pad and disc rotor are securely fitted.

REAR DISC BRAKE

< PERIODIC MAINTENANCE >

REAR DISC BRAKE

BRAKE PAD

BRAKE PAD : Inspection and Adjustment

INFOID:000000009010891

INSPECTION

Check the thickness of brake pad from the inspection hole (A) on brake caliper assembly. Check use a scale if necessary.

Wear thickness : Refer to [BR-47, "Rear Disc Brake"](#).

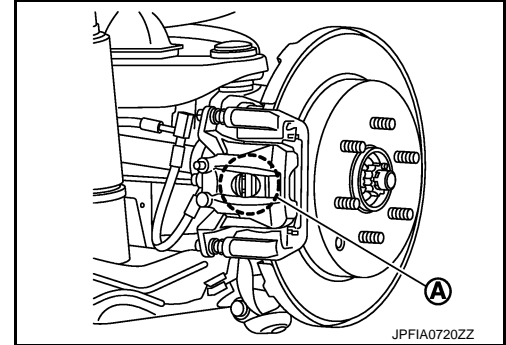

ADJUSTMENT

CAUTION:

- Burnish contact surfaces between pads according to the following procedure after refinishing or replacing brake pads, or if a soft pedal occurs at very low mileage.
- Be careful of vehicle speed because the brake does not operate firmly/securely until pads and disc rotor are securely fitted.
- Only perform this procedure under safe road and traffic conditions. Use extreme caution.

1. Drive vehicle on straight, flat road.
2. Depress brake pedal with the power to stop vehicle within 3 to 5 seconds until the vehicle stops.
3. Drive without depressing brake for a few minutes to cool the brake.
4. Repeat steps 1 to 3 until pad and disc rotor are securely fitted.

DISC ROTOR

DISC ROTOR : Inspection and Adjustment

INFOID:000000009010892

INSPECTION

Appearance

Check surface of disc rotor for uneven wear, cracks, and serious damage. Replace it if necessary. Refer to [RAX-7, "Removal and Installation"](#).

Runout

1. Fix the disc rotor to the wheel hub and bearing assembly with wheel nuts (2 points at least).
2. Check the wheel bearing axial end play before the inspection. Refer to [RAX-5, "Inspection"](#).
3. Inspect the runout with a dial indicator to measure at 10 mm (0.39 in) inside the disc edge.

Runout : Refer to [BR-47, "Rear Disc Brake"](#).

4. Find the installation position that has a minimum runout by shifting the disc rotor-to-wheel hub and bearing assembly installation position by one hole at a time if the runout exceeds the limit value.
5. Refinish the disc rotor if the runout is outside the limit even after performing the above operation. [When refinishing, use the Pro-Cut PEM On-Car brake Lathe (Tool No. 38-PFM90.5) or equivalent.]

CAUTION:

- Check in advance that the thickness of the disc rotor is wear thickness + 0.3 mm (0.012 in) or more.

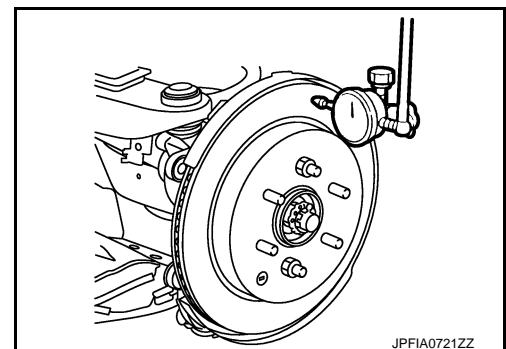

REAR DISC BRAKE

< PERIODIC MAINTENANCE >

- If the thickness is less than wear thickness + 0.3 mm (0.012 in), replace the disc rotor. Refer to [RAX-7, "Removal and Installation"](#).

Wear thickness : Refer to [BR-47, "Rear Disc Brake"](#).

Thickness

Check the thickness of the disc rotor using a micrometer. Replace the disc rotor if the thickness is below the wear limit. Refer to [RAX-7, "Removal and Installation"](#).

Wear thickness : Refer to [BR-47, "Rear Disc Brake"](#).

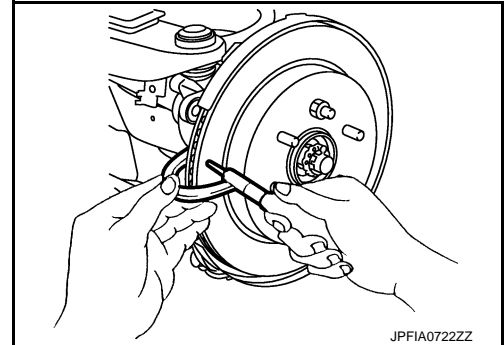

ADJUSTMENT

CAUTION:

- Burnish contact surfaces between pads according to the following procedure after refinishing or replacing brake pads, or if a soft pedal occurs at very low mileage.
 - Be careful of vehicle speed because the brake does not operate firmly/securely until pads and disc rotor are securely fitted.
 - Only perform this procedure under safe road and traffic conditions. Use extreme caution.
1. Drive vehicle on straight, flat road.
 2. Depress brake pedal with the power to stop vehicle within 3 to 5 seconds until the vehicle stops.
 3. Drive without depressing brake for a few minutes to cool the brake.
 4. Repeat steps 1 to 3 until pad and disc rotor are securely fitted.

BRAKE PEDAL

< REMOVAL AND INSTALLATION >

REMOVAL AND INSTALLATION

BRAKE PEDAL

Exploded View

INFOID:000000009010893

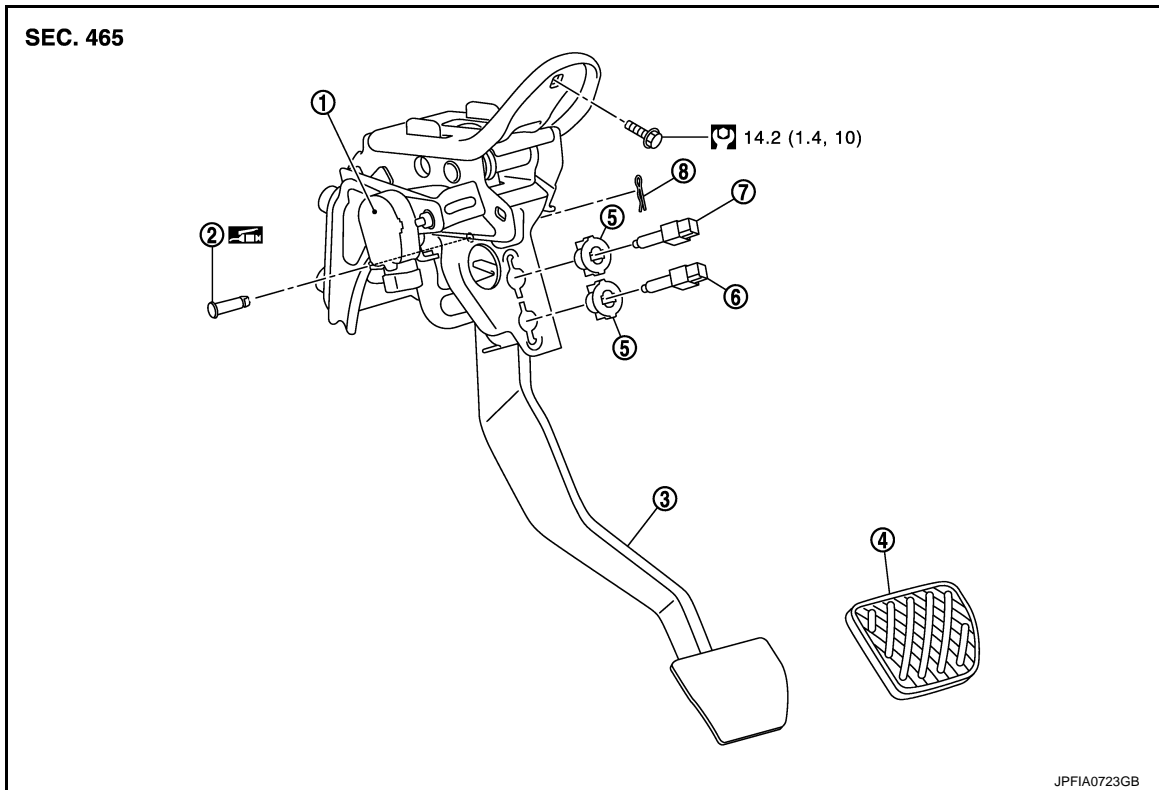

- | | | |
|---|---------------|-------------------------|
| 1. Brake pedal stroke sensor (with pre-crash seat belt) | 2. Clevis pin | 3. Brake pedal assembly |
| 4. Brake pedal pad | 5. Clip | 6. Brake switch |
| 7. Stop lamp switch | 8. Snap pin | |

 Apply multi-purpose grease.

Refer to [GI-4, "Components"](#) for symbols not described on the above.

Removal and Installation

INFOID:000000009010894

REMOVAL

CAUTION:

Never removing brake pedal stroke sensor. (With pre-crash seat belt)

1. Remove the instrument lower panel LH. Refer to [IP-14, "Removal and Installation"](#).
2. Disconnect the brake pedal stroke sensor harness connector. (With pre-crash seat belt)
3. Disconnect the stop lamp switch harness connector and brake switch harness connector.
4. Rotate the stop lamp switch and the brake switch counterclockwise to remove.
5. Remove the snap pin, and then remove the clevis pin from the clevis of brake booster.
6. Remove the brake pedal assembly.

CAUTION:

Hold the hydraulic booster assembly so as not to drop out or contact them other parts.

7. Perform inspection after removal. Refer to [BR-21, "Inspection and Adjustment"](#).

INSTALLATION

Note the following, and install in the reverse order of removal.

- Apply the multi-purpose grease to the clevis pin and the matching faces.

BRAKE PEDAL

< REMOVAL AND INSTALLATION >

- Install the brake pedal assembly and hydraulic booster assembly mounting nuts, and tighten it to the specified torque. Refer to [BR-28, "Exploded View"](#).
- Perform adjustment after installation. Refer to [BR-21, "Inspection and Adjustment"](#).

NOTE:

The clevis pin may be inserted in either direction.

Inspection and Adjustment

INFOID:000000009010895

INSPECTION AFTER REMOVAL

- Check for the following items and replace the brake pedal assembly if necessary.
 - Check the brake pedal upper rivet (made by aluminum) (B) for deformation.
 - Check the brake pedal for bend, damage, and cracks on the welded parts.
 - Check the lapping length (A) of sub-bracket (1) and slide plate (2).

A : 5.0 mm (0.197 in) or more

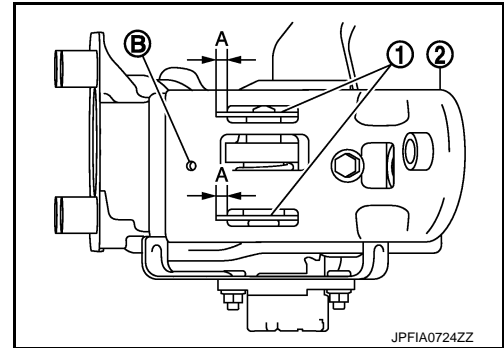

- Check clevis pin and plastic stopper (A) for damage and deformation. If any is found, replace clevis pin.

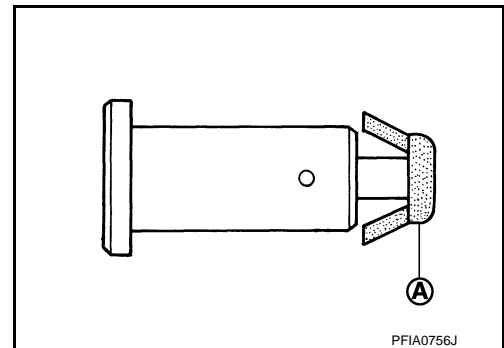

ADJUSTMENT AFTER INSTALLATION

Perform the brake pedal adjustment after installing the brake pedal assembly. Refer to [BR-7, "Inspection and Adjustment"](#).

A
B
C
D
E
BR
G
H
I
J
K
L
M
N
O
P

BRAKE PIPING

< REMOVAL AND INSTALLATION >

BRAKE PIPING FRONT

FRONT : Exploded View

INFOID:000000009010896

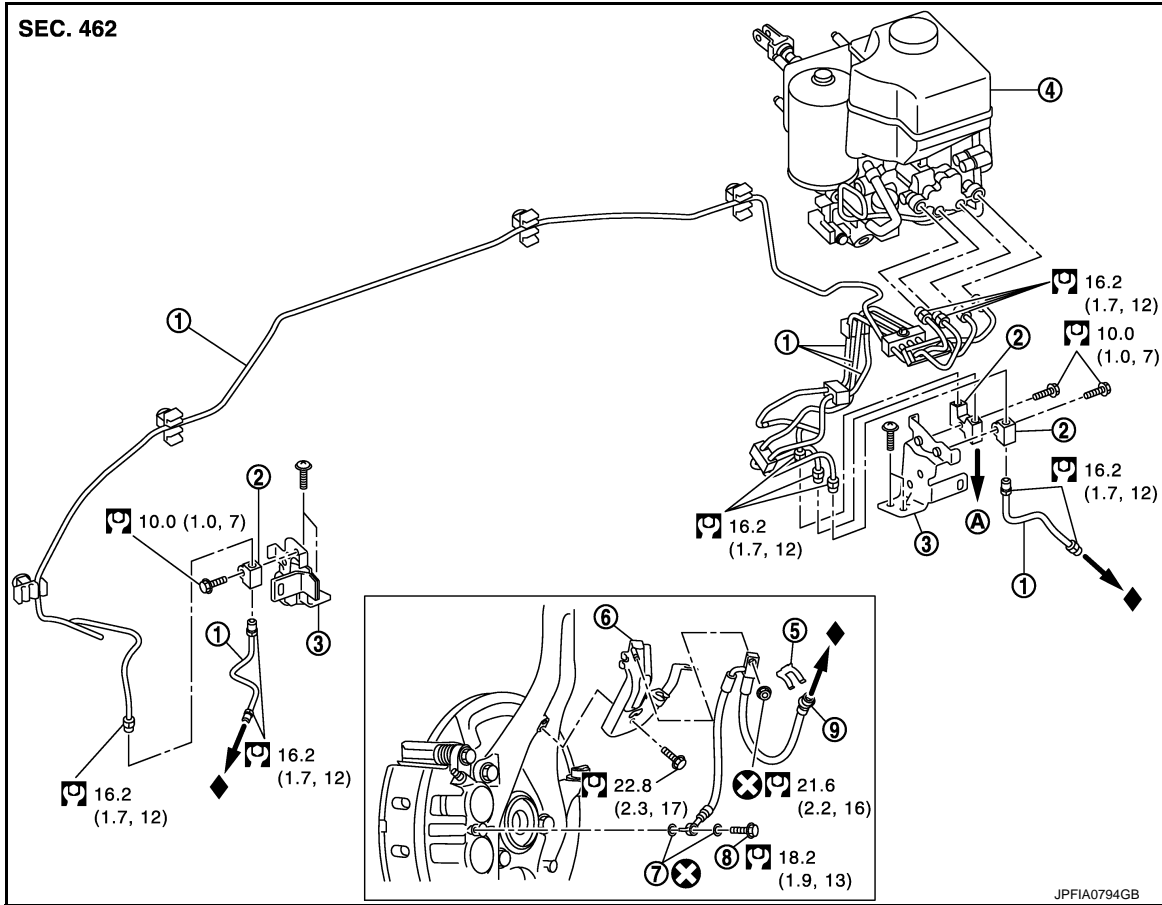

- | | | |
|-------------------------------|---------------|-----------------------|
| 1. Brake tube | 2. Connector | 3. Connector bracket |
| 4. Hydraulic booster assembly | 5. Lock plate | 6. Brake hose bracket |
| 7. Copper washer | 8. Union bolt | 9. Brake hose |
| A. To rear brake tube | | |

◆: Indicates that the part is connected at points with same symbol in actual vehicle.

Refer to [GI-4, "Components"](#) for symbols in the figure.

BRAKE PIPING

< REMOVAL AND INSTALLATION >

FRONT : Hydraulic Piping

INFOID:000000009010897

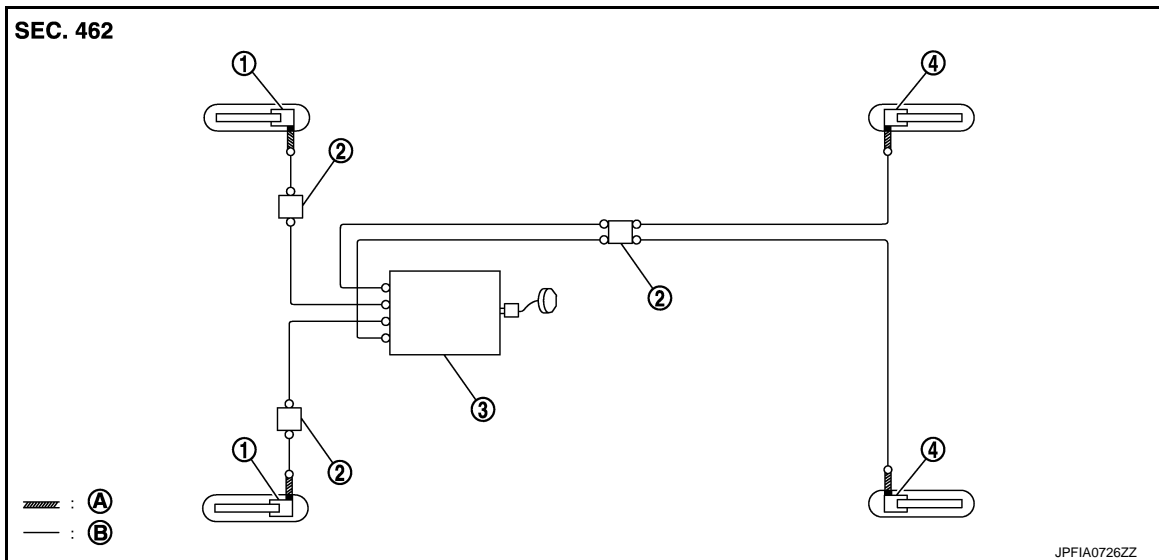

1. Front disc brake
 2. Connector
 3. Hydraulic booster assembly
 4. Rear disc brake
- A. Brake hose B. Brake tube
- : Flare nut
■: Union bolt

FRONT : Removal and Installation

INFOID:000000009010898

REMOVAL

CAUTION:

- If the brake fluid adheres to the brake caliper assembly and disc rotor, quickly wipe it off.
- Never spill or splash brake fluid on painted surfaces. Brake fluid may seriously damage paint. Wipe it off immediately and wash with water if it gets on a painted surface.
- Never depress the brake pedal. Brake fluid may splash while removing the brake hose or brake tube.

1. Remove tires with power tool.
2. Drain brake fluid. Refer to [BR-10. "Draining"](#).
3. Loosen the flare nut with a flare nut wrench and separate the brake tube and the brake hose.
CAUTION:
 - Never scratch the flare nut and the brake tube.
 - Never bend sharply, twist or strongly pull out the brake hose or brake tube.
 - Cover open end of brake hose or brake tube when disconnecting to prevent entrance of dirt.
4. Remove the union bolt and copper washers, and remove the brake hose from the brake caliper assembly.
5. Remove the brake hose mounting nut.
6. Remove the lock plate and remove the brake hose.
7. Remove the brake hose bracket.

INSTALLATION

CAUTION:

- If the brake fluid adheres to the brake caliper assembly and disc rotor, quickly wipe it off.
- Never spill or splash brake fluid on painted surfaces. Brake fluid may seriously damage paint. Wipe it off immediately and wash with water if it gets on a painted surface.
- Never depress the brake pedal. Brake fluid may splash while removing the brake hose or brake tube.

1. Install the brake hose bracket.
2. Assemble the union bolt and the copper washers to the brake hose.

CAUTION:

BRAKE PIPING

< REMOVAL AND INSTALLATION >

Never reuse the copper washer.

3. Install the brake hose L-pin by aligning it with the brake caliper assembly positioning hole, and tighten the union bolt (1) to the specified torque.
4. Install the brake tube to the brake hose, temporarily tighten the flare nut by hand until it does not rotate further, and fix the brake hose to the bracket with the lock plate.

CAUTION:

Check that all brake hose or brake tube are not twisted and bent.

5. Tighten the flare nut to the specified torque with a crowfoot and torque wrench.

CAUTION:

Never scratch the flare nut and the brake tube.

6. Tighten the brake hose mounting nuts to the specified torque.

CAUTION:

Never reuse the brake hose mounting nuts.

7. Perform the air bleeding. Refer to [BR-11, "Bleeding Brake System"](#).
8. Install tires with power tool. Refer to [WT-63, "Exploded View"](#).
9. Perform inspection after installation. Refer to [BR-24, "FRONT : Inspection"](#).

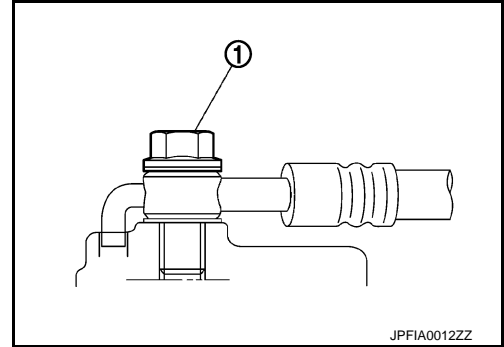

FRONT : Inspection

INFOID:000000009010899

INSPECTION AFTER INSTALLATION

1. Check the brake hoses and tubes for the following: no scratches; no twist and deformation; no interference with other components when steering the steering wheel; no looseness at connections.
2. Depress the brake pedal with a force of 785 N (80 kg, 176 lb) and hold down the pedal for approx. 5 seconds with the engine running. Check for any fluid leakage.

CAUTION:

Retighten the applicable connection to the specified torque and repair any abnormal (damaged, worn or deformed) part if any brake fluid leakage is present.

REAR

BRAKE PIPING

< REMOVAL AND INSTALLATION >

REAR : Exploded View

INFOID:000000009010900

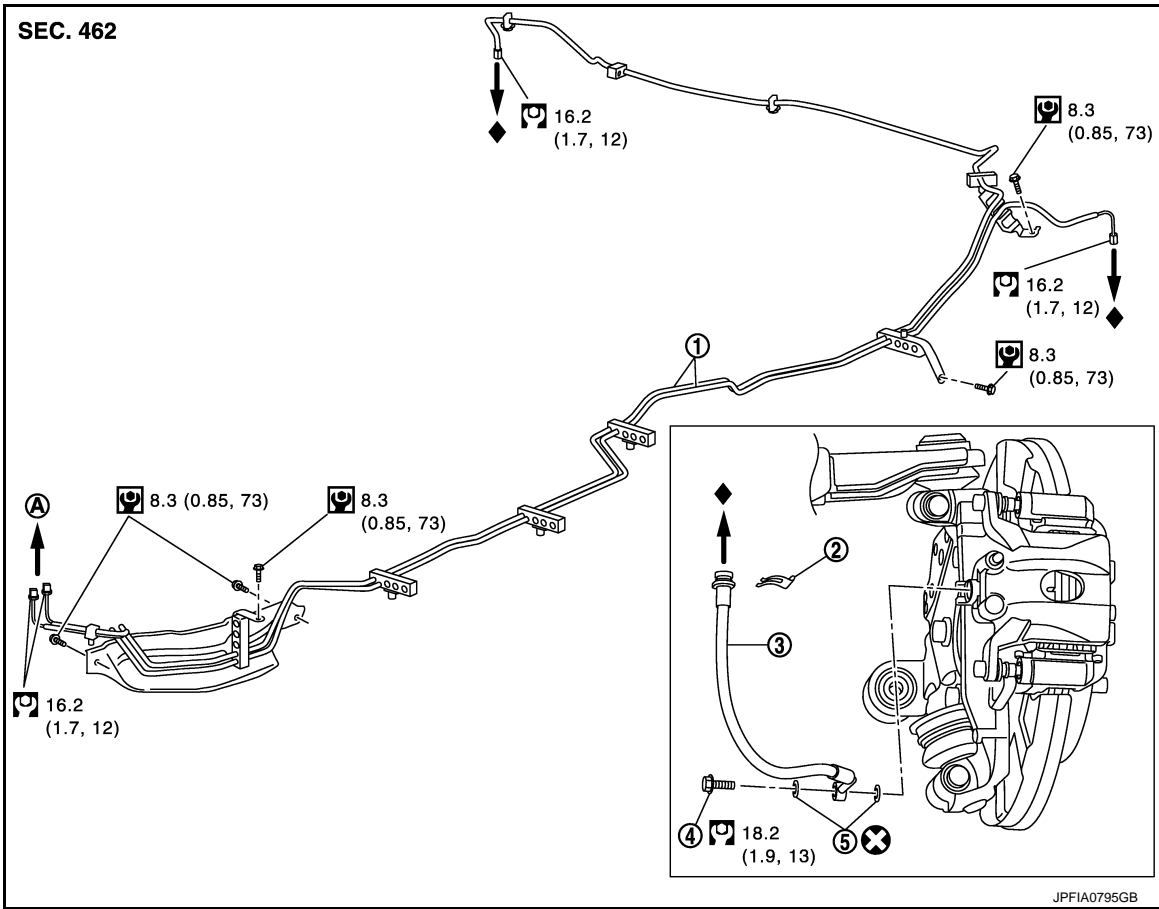

- 1. Brake tube
- 2. Lock plate
- 3. Brake hose
- 4. Union bolt
- 5. Copper washer
- A. To connector

◆: Indicates that the part is connected at points with same symbol in actual vehicle.

Refer to [GI-4, "Components"](#) for symbols in the figure.

REAR : Hydraulic Piping

INFOID:000000009010901

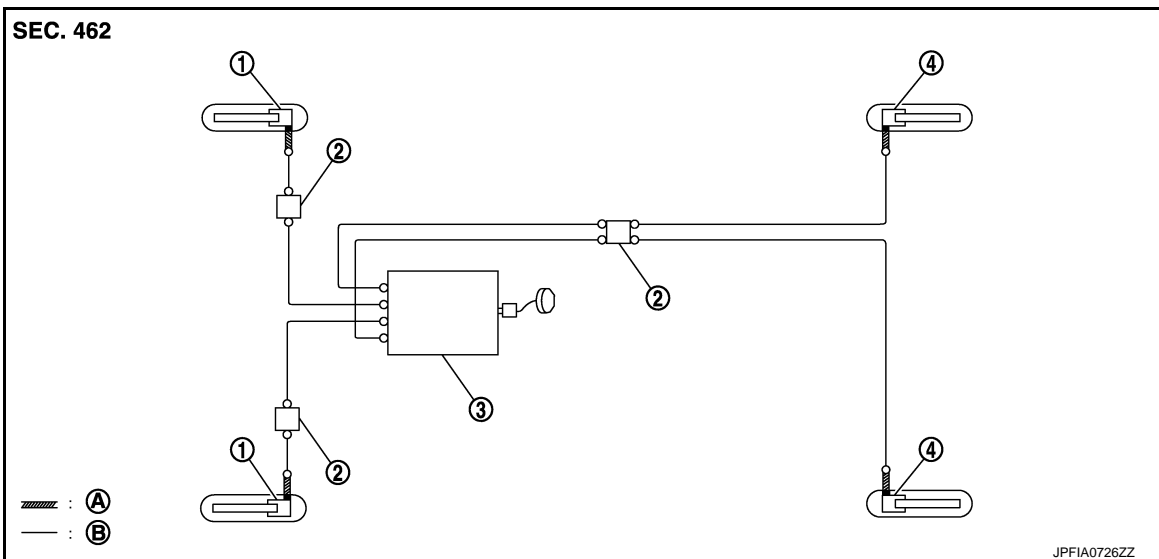

BRAKE PIPING

< REMOVAL AND INSTALLATION >

1. Front disc brake
 2. Connector
 3. Hydraulic booster assembly
 4. Rear disc brake
 - A. Brake hose
 - B. Brake tube
- : Flare nut
■: Union bolt

REAR : Removal and Installation

INFOID:000000009010902

REMOVAL

CAUTION:

- If the brake fluid adheres to the brake caliper assembly and disc rotor, quickly wipe it off.
- Never spill or splash brake fluid on painted surfaces. Brake fluid may seriously damage paint. Wipe it off immediately and wash with water if it gets on a painted surface.
- Never depress the brake pedal. Brake fluid may splash while removing the brake hose or brake tube.

1. Remove tires with power tool.
2. Drain brake fluid. Refer to [BR-10, "Draining"](#).
3. Loosen the flare nut with a flare nut wrench and separate the brake tube and the brake hose.

CAUTION:

- Never scratch the flare nut and the brake tube.
- Never bend sharply, twist or strongly pull out the brake hose or brake tube.
- Cover open end of brake hose or brake tube when disconnecting to prevent entrance of dirt.

4. Remove the union bolt and copper washers, and remove the brake hose from the brake caliper assembly.
5. Remove the lock plate and remove the brake hose.

INSTALLATION

CAUTION:

- If the brake fluid adheres to the brake caliper assembly and disc rotor, quickly wipe it off.
- Never spill or splash brake fluid on painted surfaces. Brake fluid may seriously damage paint. Wipe it off immediately and wash with water if it gets on a painted surface.
- Never depress the brake pedal. Brake fluid may splash while removing the brake hose or brake tube.

1. Assemble the union bolt and the copper washers to the brake hose.

CAUTION:

Never reuse the copper washer.

2. Align the brake hose pin to the projection (A) of the brake caliper assembly and tighten the union bolt (1) to the specified torque.
3. Install the brake tube to the brake hose, temporarily tighten the flare nut by hand until it does not rotate further, and fix the brake hose to the bracket with the lock plate.

CAUTION:

Check that all brake hose or brake tube are not twisted and bent.

4. Tighten the flare nut to the specified torque with a crowfoot and torque wrench.

CAUTION:

Never scratch the flare nut and the brake tube.

5. Perform the air bleeding. Refer to [BR-11, "Bleeding Brake System"](#).
6. Install tires with power tool. Refer to [WT-63, "Exploded View"](#).
7. Perform inspection after installation. Refer to [BR-26, "REAR : Inspection"](#).

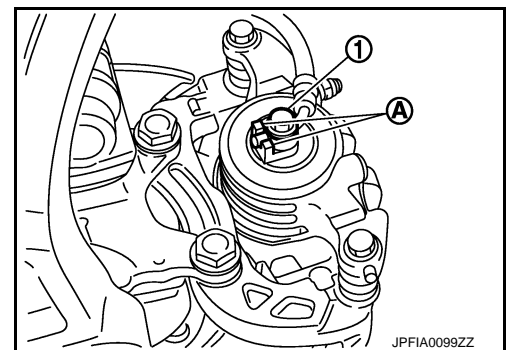

REAR : Inspection

INFOID:000000009010903

INSPECTION AFTER INSTALLATION

1. Check the brake hoses and tubes for the following: no scratches; no twist and deformation; no interference with other components when steering the steering wheel; no looseness at connections.

BRAKE PIPING

< REMOVAL AND INSTALLATION >

2. Depress the brake pedal with a force of 785 N (80 kg, 176 lb) and hold down the pedal for approx. 5 seconds with the engine running. Check for any fluid leakage.

CAUTION:

Retighten the applicable connection to the specified torque and repair any abnormal (damaged, worn or deformed) part if any brake fluid leakage is present.

A
B
C
D
E
G
H
I
J
K
L
M
N
O
P

BR

HYDRAULIC BOOSTER ASSEMBLY

< REMOVAL AND INSTALLATION >

HYDRAULIC BOOSTER ASSEMBLY

Exploded View

INFOID:000000009010904

REMOVAL

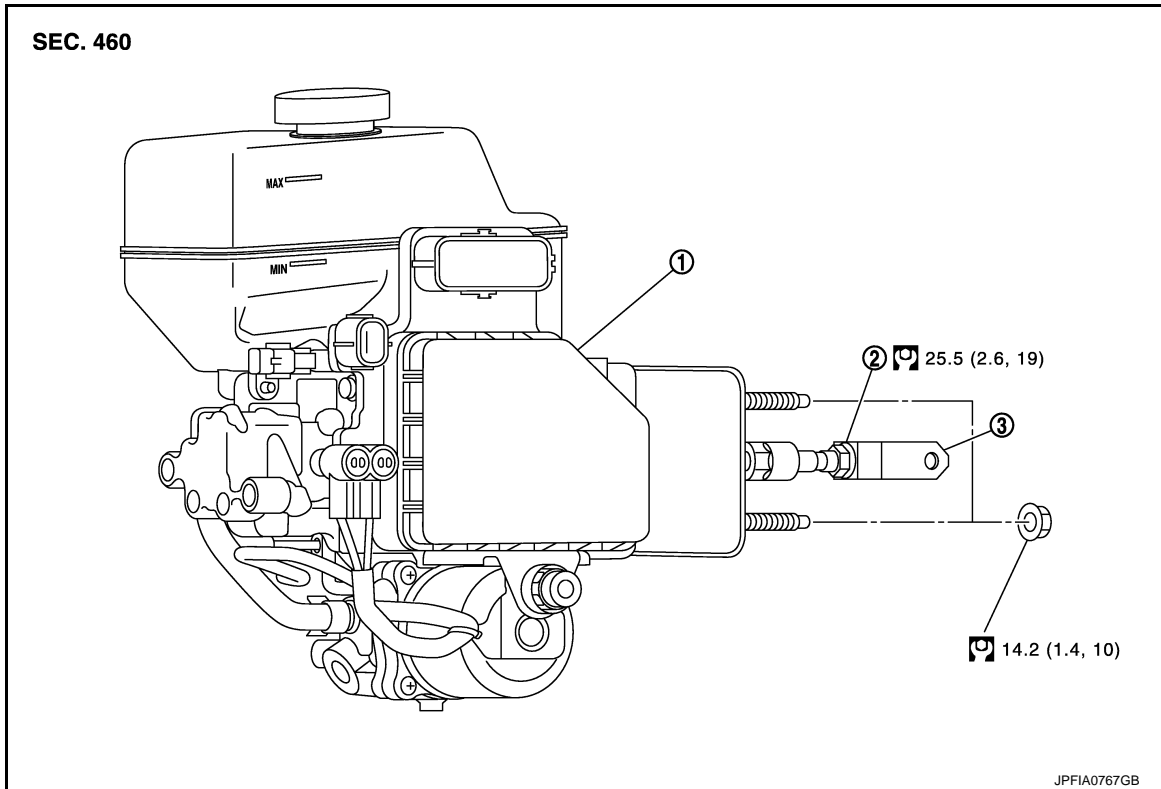

1. Hydraulic booster assembly

2. Lock nut

3. Clevis

Refer to [GI-4, "Components"](#) for symbols in the figure.

DISASSEMBLY

HYDRAULIC BOOSTER ASSEMBLY

< REMOVAL AND INSTALLATION >

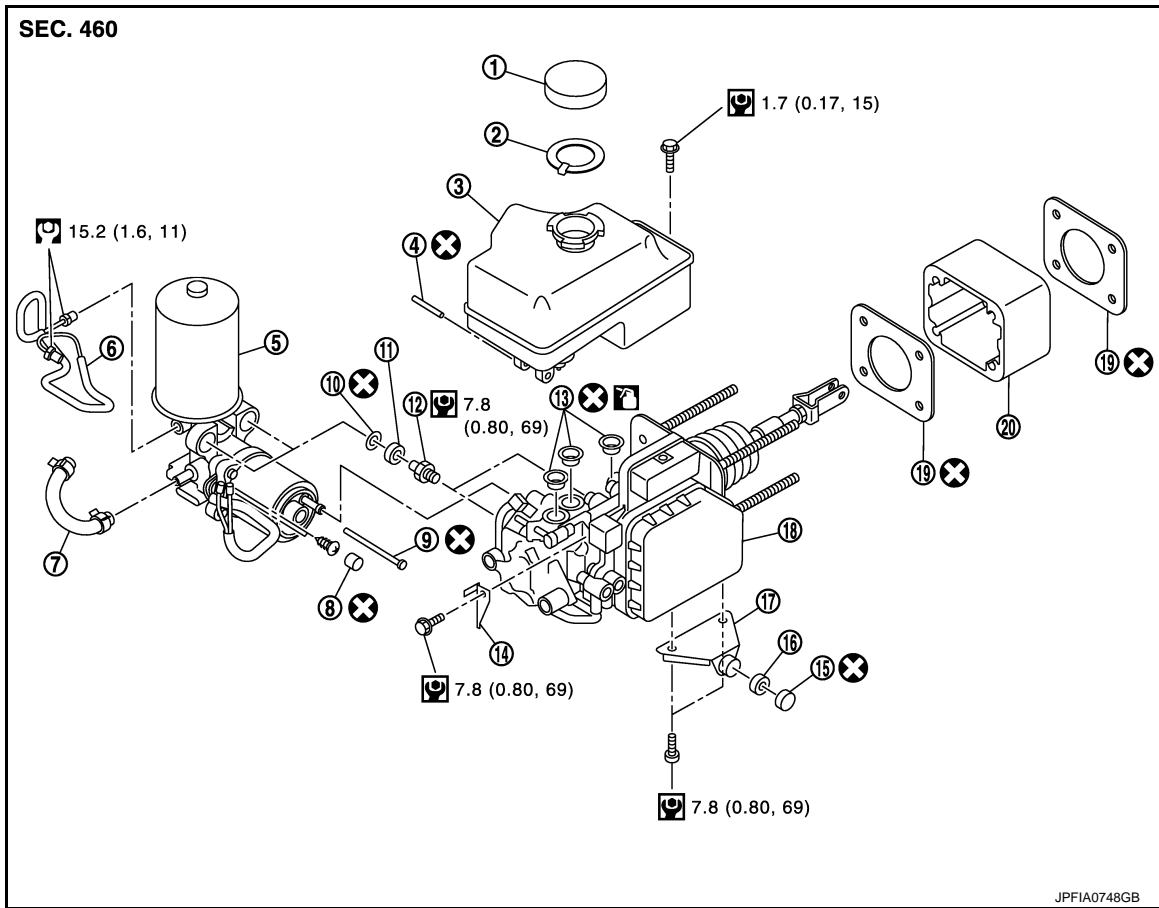

- | | | |
|------------------------|-------------------------------|---|
| 1. Reservoir cap | 2. Label | 3. Reservoir tank |
| 4. Pin | 5. Motor/accumulator assembly | 6. Brake tube |
| 7. Brake hose assembly | 8. Grommet | 9. Harness band |
| 10. Collar | 11. Bushing | 12. Pin mount |
| 13. Grommet | 14. Bracket | 15. Cap |
| 16. Bushing | 17. Bracket | 18. ABS actuator and electric unit (control unit) |
| 19. Gasket | 20. Spacer | |

: Apply brake fluid.

Refer to [GI-4, "Components"](#) for symbols not described on the above.

Removal and Installation

INFOID:000000009010905

REMOVAL

- Turn the ignition switch OFF.
CAUTION:
Never turn the ignition switch ON before the completion of the installation procedure.
- Drain brake fluid. Refer to [BR-10, "Draining"](#).
- Depress the brake pedal 20 times or more to release the pressure from the accumulator.
CAUTION:
Always perform this step before removing the hydraulic booster assembly.
- Disconnect hydraulic booster assembly harness connector.
- Separate the brake tube from hydraulic booster assembly with a flare nut wrench. Refer to [BR-22, "FRONT : Exploded View"](#).
- Remove brake tube from clip.

HYDRAULIC BOOSTER ASSEMBLY

< REMOVAL AND INSTALLATION >

7. Remove snap pin (1) and clevis pin (2) from clevis.
8. Remove nuts on hydraulic booster assembly and brake pedal assembly.

CAUTION:

Hold the hydraulic booster assembly so as to avoid dropping out.

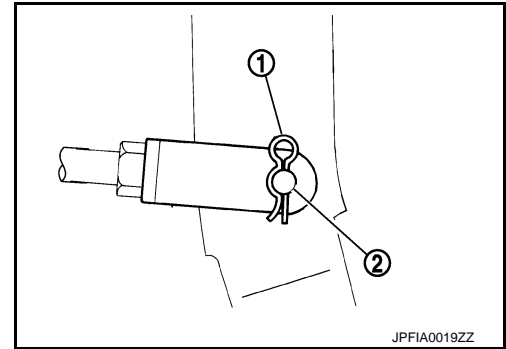

9. Remove hydraulic booster assembly.

CAUTION:

- Always hold (A) when removing the hydraulic booster assembly.
- Never deform or bend the brake tubes when removing the hydraulic booster assembly.
- Always use a cushion or an equivalent to place the hydraulic booster assembly. Failure to do this may cause uneven loads or impact and result in a malfunction.

10. After replacing hydraulic booster assembly, always follow the accumulator disposal procedure to discard the hydraulic booster assembly. Refer to [BR-33, "Disposal"](#).

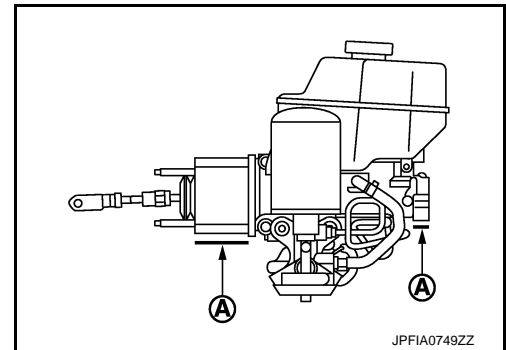

INSTALLATION

Note the following, and install in the reverse order of removal.

- Perform adjustment before installation. Refer to [BR-32, "Inspection and Adjustment"](#).
- Never reuse a hydraulic booster assembly after an excessive impact. (Slight impulse caused during installation work is acceptable.)
- Never turn the ignition switch ON before the completion of the installation procedure.
- Be careful not to damage hydraulic booster assembly stud bolt threads. If hydraulic booster assembly is tilted during installation, the dash panel may damage the threads.
- Always hold (A) when installing the hydraulic booster assembly.
- Never deform or bend the brake tubes when installing the hydraulic booster assembly.
- Always use a new gasket between the hydraulic booster assembly, spacer and the dash panel.
- Replace the clevis pin if it is damaged. Refer to [BR-21, "Inspection and Adjustment"](#).
- Perform the air bleeding. Refer to [BR-11, "Bleeding Brake System"](#).
- Perform the brake pedal adjustment after installing the brake pedal assembly and hydraulic booster assembly. Refer to [BR-7, "Inspection and Adjustment"](#).
- Perform inspection after installation. Refer to [BR-32, "Inspection and Adjustment"](#).

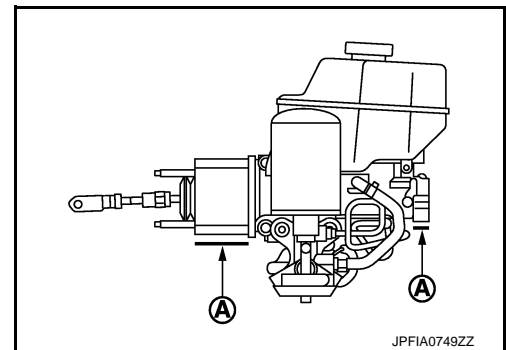

Disassembly and Assembly

INFOID:000000009010906

DISASSEMBLY

CAUTION:

Disassemble the hydraulic booster assembly when necessary.

1. Remove gaskets and spacer from hydraulic booster assembly.

HYDRAULIC BOOSTER ASSEMBLY

< REMOVAL AND INSTALLATION >

2. Remove the reservoir tank mounting pin with a pin punch (commercial service tool).
3. Remove bolt and remove the reservoir tank and grommets from the ABS actuator and electric unit (control unit).
CAUTION:
Never drop the removed parts. The parts must not be reused if they are dropped.
4. Slide the clamp and remove brake hose assembly.
5. Remove the brake tube with a flare nut wrench.
CAUTION:
Never scratch the flare nut and the brake tube.
6. Remove the cap with a suitable tool (A).

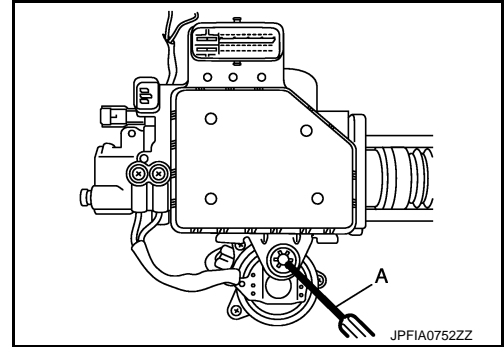
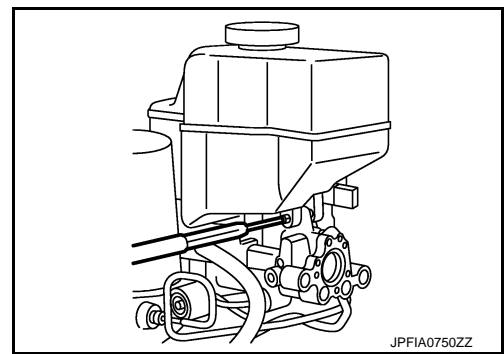

7. Remove grommets and screws (←) and remove motor/accumulator assembly harness.
8. Cut harness band.
CAUTION:
Never damage the harness.
9. Remove motor/accumulator assembly from ABS actuator and electric unit (control unit).
10. Remove bushings and collars from motor/accumulator assembly.
11. Remove brackets and bushing from ABS actuator and electric unit (control unit).
12. Remove pin mount.
13. After replacing motor/accumulator assembly, always follow the accumulator disposal procedure to discard the motor/accumulator assembly. Refer to [BR-33. "Disposal"](#).

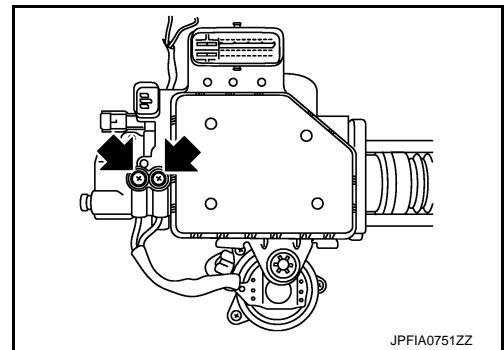

ASSEMBLY

Note the following, and assembly in the reverse order of disassembly.

- Never use mineral oils such as kerosene or gasoline and rubber grease during the cleaning and assembly process.
- Never drop the removed parts when installing. The parts must not be reused if they are dropped.
- Never allow foreign matter (e.g. dust) and oils other than brake fluid to enter the reservoir tank.
- For non reusable parts, refer to [BR-28. "Exploded View"](#).
- When connecting motor/accumulator assembly harness, check the order of harness colors.

A : Black

B : Red

- Temporarily tighten the brake tube flare nut to the motor/accumulator assembly and ABS actuator and electric unit (control unit) by hand. Then tighten it to the specified torque with a crowfoot and torque wrench.

CAUTION:

Never scratch the flare nut and the brake tube.

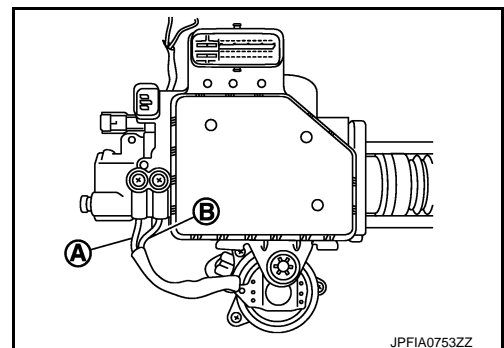

A
B
C
D
E
BR
G
H
I
J
K
L
M
N
O
P

HYDRAULIC BOOSTER ASSEMBLY

< REMOVAL AND INSTALLATION >

- Apply new brake fluid to grommet of between reservoir tank and grommet and ABS actuator and electric unit (control unit).

Inspection and Adjustment

INFOID:000000009010907

ADJUSTMENT BEFORE INSTALLATION

Input Rod Length adjustment

1. Loosen the lock nut (1) and adjust the input rod (2) to the specified length (A).

A : Refer to [BR-47, "Brake Booster"](#).

2. Tighten the lock nut to the specified torque.

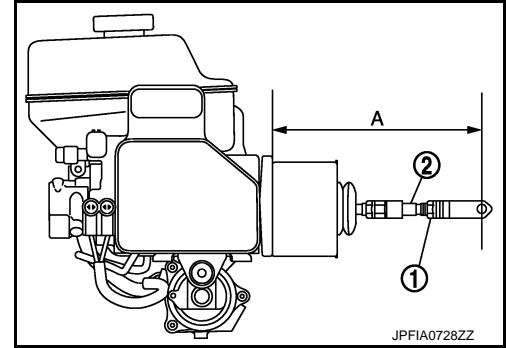

INSPECTION AFTER INSTALLATION

Operation Check

1. Turn the ignition switch OFF.
2. Depress the brake pedal 20 times or more.
NOTE:
The pressure loss in the accumulator results in a large brake pedal stroke. In addition to this, the brake pedal depression becomes lighter in initial stage.
3. Check that the fluid level in the reservoir tank is MAX line.
4. Position the selector lever in P range to release the parking brake.
5. Turn the ignition switch ON to check the time between motor activation and motor stop.

Motor operating time : 18 seconds or less

6. After the motor is stopped, check that the ABS warning lamp and the VDC warning lamp in the combination meter are OFF when the engine is started.
7. Stop the engine (ignition switch OFF).
8. Turn the ignition switch ON and depress the brake pedal 4 to 5 times to check the time between motor activation and motor stop.

Motor operating time : 2 – 11 seconds

9. Turn the ignition switch OFF. Turn the ignition switch ON again. Check that the VDC warning lamp turns ON when the brake pedal is depressed 15 to 20 times.
10. Check that the VDC warning lamp turns ON when the brake pedal is depressed 15 to 20 times after the lapse of 120 seconds or more after the ignition switch is turned ON again.
11. Perform the self-diagnosis for "ABS" with CONSULT and erase all the stored self-diagnosis results.

Function Check

1. Turn the ignition switch OFF.
2. Depress the brake pedal 20 times or more.
NOTE:
The pressure loss in the accumulator results in a large brake pedal stroke. In addition to this, the brake pedal depression becomes lighter in initial stage.
3. Turn the ignition switch ON with the brake pedal depressed to check that the clearance between the brake pedal and the dash lower panel decreases.

HYDRAULIC BOOSTER ASSEMBLY

< REMOVAL AND INSTALLATION >

Disposal

INFOID:000000009010908

1. Remove accumulator (2) from motor/accumulator assembly (1).

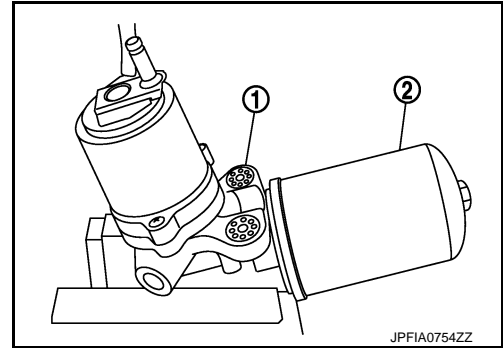

2. Fix the accumulator (1) to a vise.

CAUTION:

- Always set copper plates or cloth between vise grips when fixing the accumulator to a vise.
- Never overtighten the vise.

3. Make a slit in the area (A) with a saw to release filler gas.

A : 50 mm (1.97 in)

CAUTION:

- Wear eye protection (safety glasses).
- Wear gloves.
- A cut in the area must be made perpendicularly.
- Perform the procedure slowly.
- Cover with cloth to avoid sawdust to spatter.

NOTE:

The gas is clear colorless, odorless, and harmless.

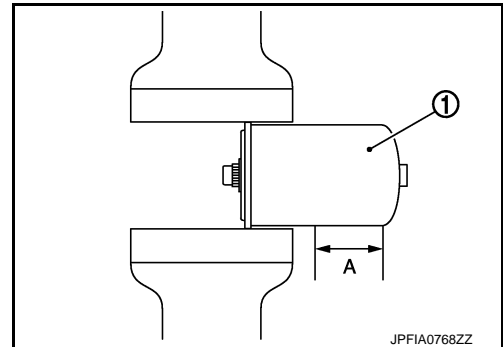

A
B
C
D
E
BR
G
H
I
J
K
L
M
N
O
P

FRONT DISC BRAKE

< REMOVAL AND INSTALLATION >

FRONT DISC BRAKE

BRAKE PAD

BRAKE PAD : Exploded View

INFOID:000000009010909

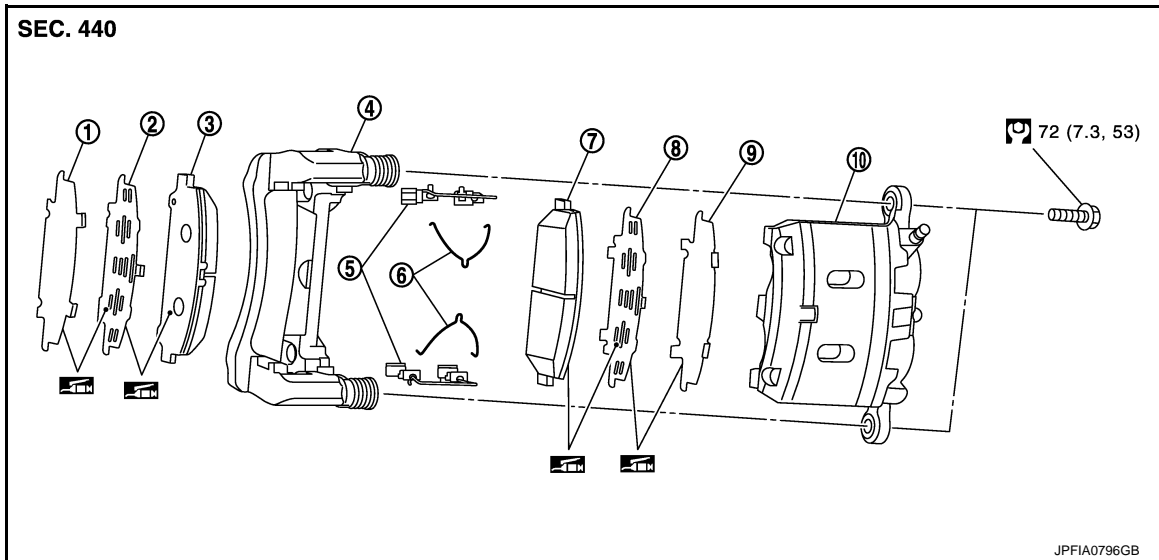

- | | | |
|-------------------------------------|-----------------|----------------------|
| 1. Outer shim cover | 2. Outer shim | 3. Outer pad |
| 4. Torque member | 5. Pad retainer | 6. Pad return spring |
| 7. Inner pad (with pad wear sensor) | 8. Inner shim | 9. Inner shim cover |
| 10. Cylinder body | | |

 Apply MOLYKOTE® AS880N or silicone-based grease.

Refer to [GI-4, "Components"](#) for symbols not described on the above.

Molykote is a registered trademark of Dow Corning Corporation.

BRAKE PAD : Removal and Installation

INFOID:000000009010910

REMOVAL

WARNING:

Since dust covering the front brake has an affect on human body, the dust must be removed with a dust collector. Never splatter the dust with an air blow gun.

CAUTION:

- Never depress the brake pedal while removing the brake pads because the piston may pop out.
- If the brake fluid or grease adheres to the brake caliper assembly and disc rotor, quickly wipe it off.

1. Remove tires with power tool.
2. Remove lower sliding pin bolt.
3. Suspend the cylinder body with suitable wire so that the brake hose will not stretch.
4. Remove the pad return springs (1). Then remove brake pads, shims and shim covers.

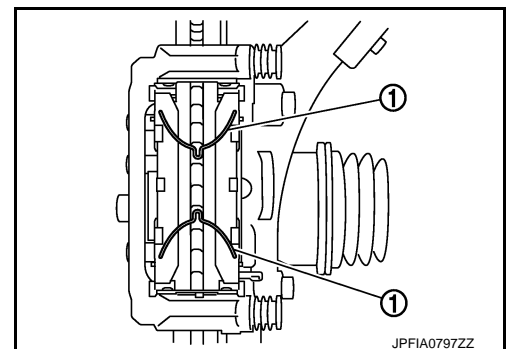

FRONT DISC BRAKE

< REMOVAL AND INSTALLATION >

CAUTION:

- Never deform the pad retainer when removing the pad retainers (2) from the torque member (1).
- Never damage the piston boot.
- Never drop the brake pads, shims and shim covers.
- Remember each position of the removed brake pads.

5. Perform inspection after removal. Refer to [BR-36. "BRAKE PAD : Inspection"](#).

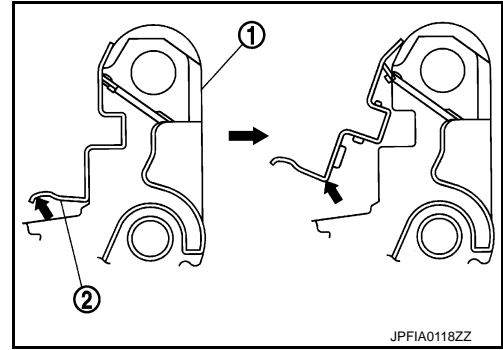

INSTALLATION

WARNING:

Since dust covering the front brake has an affect on human body, the dust must be removed with a dust collector. Never splatter the dust with an air blow gun.

CAUTION:

- Never depress the brake pedal while removing the brake pads because the piston may pop out.
- If the brake fluid or grease adheres to the brake caliper assembly and disc rotor, quickly wipe it off.

1. Install the torque member if the pad retainers has been removed.

CAUTION:

- Securely assemble the pad retainers (1) so that it will not be lifted up from the torque member (2).
- Never deform the pad retainers.

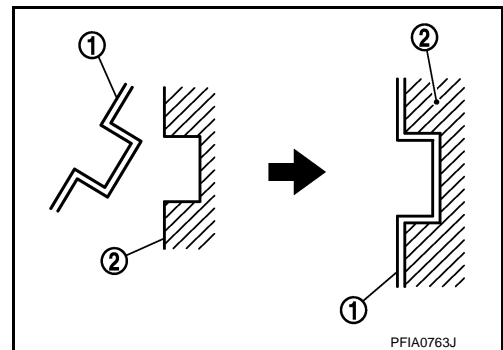

2. Apply MOLYKOTE® AS880N or silicone-based grease mating faces (A and B) between the brake pad, shim and shim cover, and install shim and shim cover to the brake pad.

CAUTION:

Always replace the shims and shim covers when replacing the brake pad.

Molykote is a registered trademark of Dow Corning Corporation.

3. Install the brake pads to the torque member.

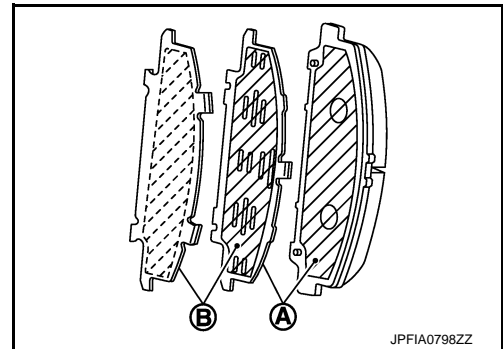

4. Install pad return springs (1).

CAUTION:

Correctly insert the pad return spring into the pad return spring hole on the brake pad.

5. Install cylinder body to torque member.

CAUTION:

- Never damage the piston boot.
- When replacing brake pad with new one, check a brake fluid level in the reservoir tank because brake fluid returns to reservoir tank when pressing piston in.

NOTE:

Use a disc brake piston tool to easily press piston.

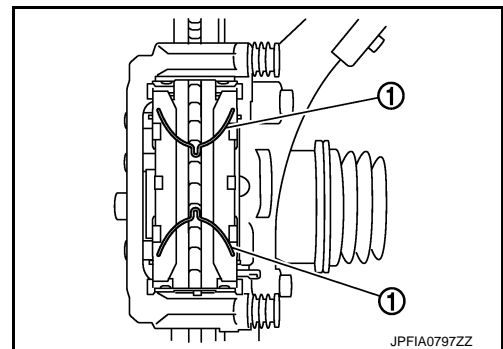

FRONT DISC BRAKE

< REMOVAL AND INSTALLATION >

6. Install lower sliding bolt and tighten it to the specified torque.
7. Depress the brake pedal several times to check that no drag feel is present for the front disc brake. Refer to [BR-36, "BRAKE PAD : Inspection"](#).
8. Install tires with power tool. Refer to [WT-63, "Exploded View"](#).

BRAKE PAD : Inspection

INFOID:000000009010911

INSPECTION AFTER REMOVAL

- Replace the shims and shim covers if rust is excessively attached.
- Eliminate rust on the pad retainers and the torque member. Replace them if rust is excessively attached.

INSPECTION AFTER INSTALLATION

1. Check a drag of front disc brake. If any drag is found, follow the procedure described below.
2. Remove brake pads. Refer to [BR-34, "BRAKE PAD : Removal and Installation"](#).
3. Press the pistons. Refer to [BR-34, "BRAKE PAD : Removal and Installation"](#).
4. Install brake pads. Refer to [BR-34, "BRAKE PAD : Removal and Installation"](#).
5. Depress the brake pedal several times.
6. Check a drag of front disc brake again. If any drag is found, disassemble the caliper. Refer to [BR-38, "BRAKE CALIPER ASSEMBLY : Disassembly and Assembly"](#).
7. Burnish contact surfaces brake pads and disc rotor after refinishing or replacing brake pads, or if a soft pedal occurs at very low mileage. Refer to [BR-16, "BRAKE PAD : Inspection and Adjustment"](#).

BRAKE CALIPER ASSEMBLY

BRAKE CALIPER ASSEMBLY : Exploded View

INFOID:000000009010912

REMOVAL

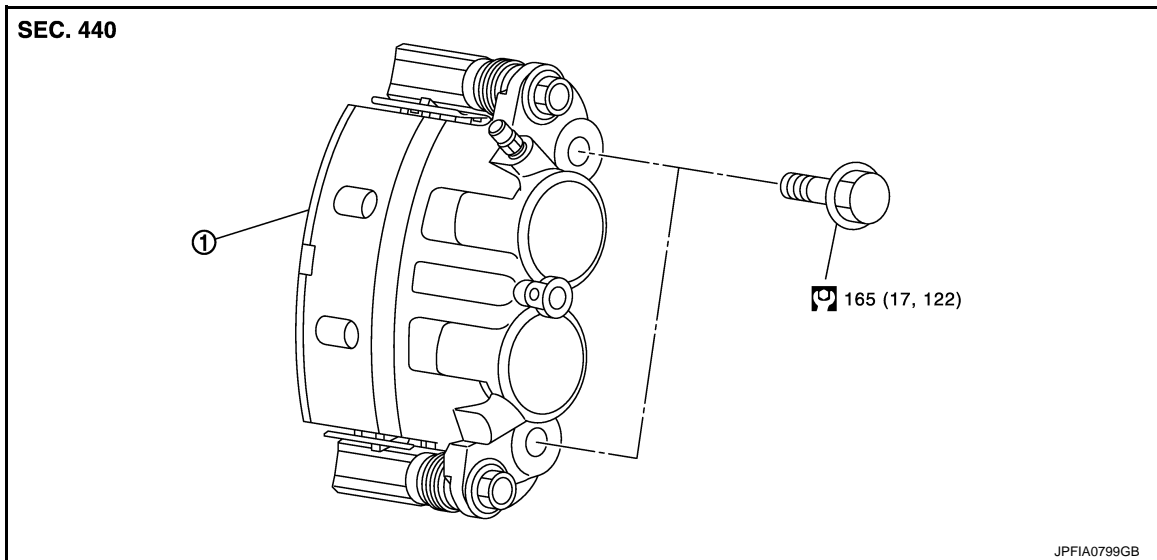

1. Brake caliper assembly

Refer to [GI-4, "Components"](#) for symbols in the figure.

DISASSEMBLY

FRONT DISC BRAKE

< REMOVAL AND INSTALLATION >

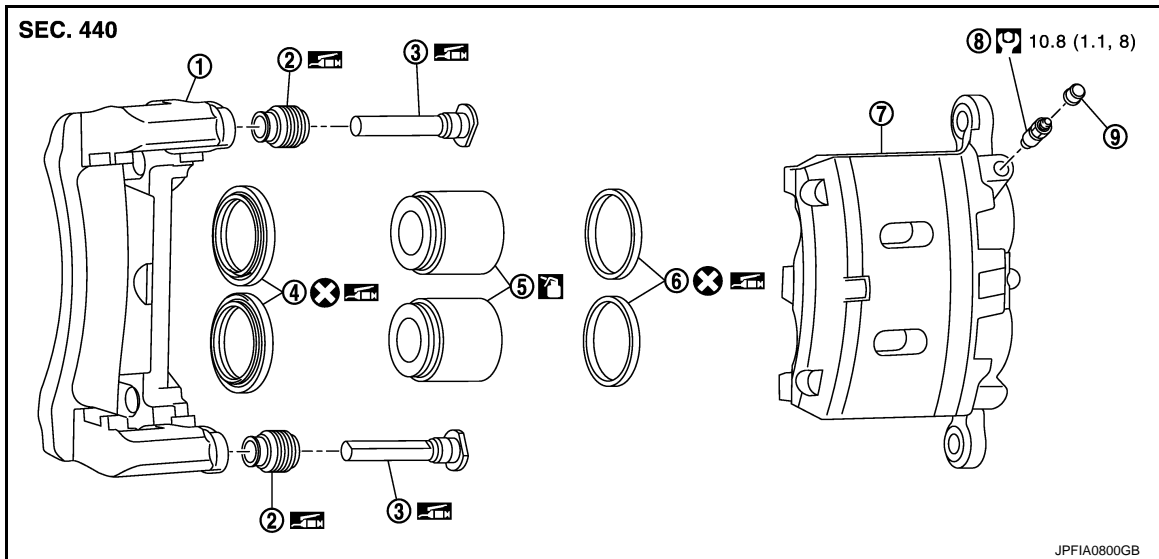

- | | | |
|------------------|---------------------|----------------|
| 1. Torque member | 2. Sliding pin boot | 3. Sliding pin |
| 4. Piston boot | 5. Piston | 6. Piston seal |
| 7. Cylinder body | 8. Bleeder valve | 9. Cap |

: Apply rubber grease.

: Apply brake fluid.

Refer to [GI-4, "Components"](#) for symbols not described on the above.

BRAKE CALIPER ASSEMBLY : Removal and Installation

INFOID:000000009010913

REMOVAL

WARNING:

Since dust covering the front brake has an affect on human body, the dust must be removed with a dust collector. Never splatter the dust with an air blow gun.

CAUTION:

- Never spill or splash brake fluid on painted surfaces. Brake fluid may seriously damage paint. Wipe it off immediately and wash with water if it gets on a painted surface.
- Never depress the brake pedal. Brake fluid may splash while removing the brake hose.
- If the brake fluid or grease adheres to the brake caliper assembly and disc rotor, quickly wipe it off.

1. Remove tires with power tool.
2. Fix the disc rotor using wheel nuts.
3. Drain brake fluid. Refer to [BR-10, "Draining"](#).
4. Separate brake hose from brake caliper assembly. Refer to [BR-23, "FRONT : Removal and Installation"](#).
5. Remove torque member mounting bolts, and remove brake caliper assembly.

CAUTION:

Never drop brake pad and brake caliper assembly.

6. Remove disc rotor. Refer to [FAX-7, "Removal and Installation"](#) (2WD), [FAX-17, "Removal and Installation"](#) (4WD).

INSTALLATION

WARNING:

Since dust covering the front brake has an affect on human body, the dust must be removed with a dust collector. Never splatter the dust with an air blow gun.

CAUTION:

- Never spill or splash brake fluid on painted surfaces. Brake fluid may seriously damage paint. Wipe it off immediately and wash with water if it gets on a painted surface.
- Never depress the brake pedal. Brake fluid may splash while removing the brake hose.
- If the brake fluid or grease adheres to the brake caliper assembly and disc rotor, quickly wipe it off.

FRONT DISC BRAKE

< REMOVAL AND INSTALLATION >

1. Install disc rotor. Refer to [FAX-7, "Removal and Installation"](#) (2WD), [FAX-17, "Removal and Installation"](#) (4WD).
2. Install the brake caliper assembly to the steering knuckle and tighten the torque member mounting bolts to the specified torque.
CAUTION:
Never spill or splash any grease and moisture on the torque member mounting face, threads, mounting bolts. Wipe out any grease and moisture.
3. Install brake hose to brake caliper assembly. Refer to [BR-23, "FRONT : Removal and Installation"](#).
4. Perform the air bleeding. Refer to [BR-11, "Bleeding Brake System"](#).
5. Check a drag of front disc brake. If any drag is found, refer to [BR-39, "BRAKE CALIPER ASSEMBLY : Inspection"](#).
6. Install tires with power tool. Refer to [WT-63, "Exploded View"](#).

BRAKE CALIPER ASSEMBLY : Disassembly and Assembly

INFOID:000000009010914

DISASSEMBLY

NOTE:

Never remove the torque member, brake pads and pad retainers when disassembling and assembling the cylinder body.

1. Remove the sliding pin bolt, and remove the cylinder body from the torque member.

CAUTION:

Fix the brake pad at suitable tape so that the brake pad will not drop.

2. Remove sliding pin boots from torque member.
3. Place a wooden block as shown in the figure, and blow air from brake hose mounting hole to remove pistons and piston boots.

CAUTION:

Never get fingers caught in the pistons.

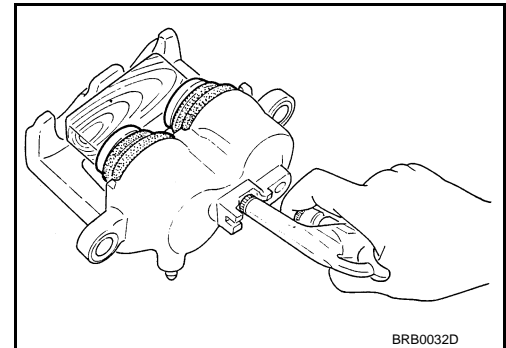

4. Remove piston seals from cylinder body using suitable tool.

CAUTION:

Be careful not to damage a cylinder inner wall.

5. Remove bleeder valve and cap.
6. Perform inspection after disassembly. Refer to [BR-39, "BRAKE CALIPER ASSEMBLY : Inspection"](#).

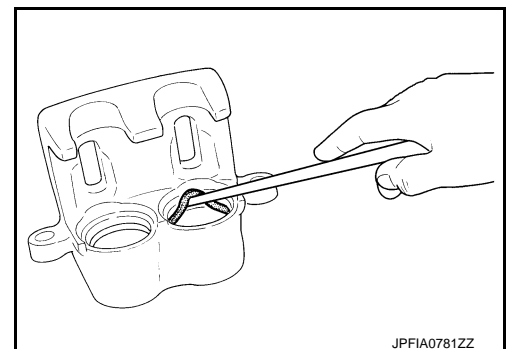

ASSEMBLY

1. Install bleeder valve and cap.

FRONT DISC BRAKE

< REMOVAL AND INSTALLATION >

2. Apply rubber grease to piston seals (1), and install them to caliper.

CAUTION:

Never reuse piston seals.

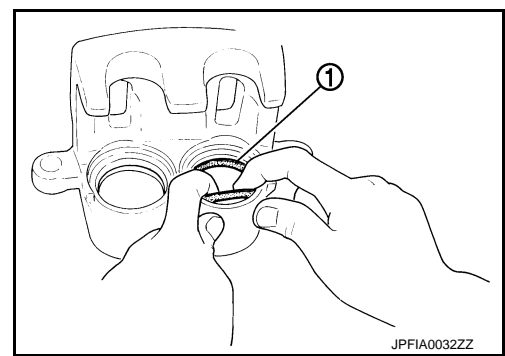

3. Apply rubber grease to piston boots (1). Cover the piston (2) end with piston boot, and then install cylinder side lip on piston boots securely into a groove on cylinder body.

CAUTION:

Never reuse piston boots.

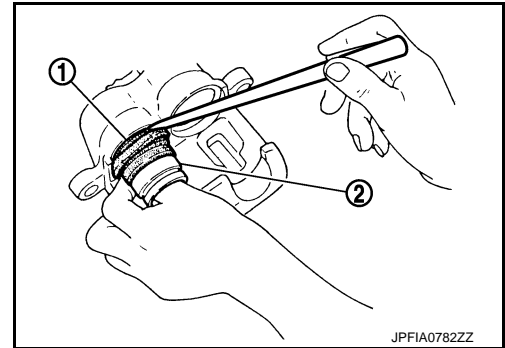

4. Apply new brake fluid to pistons (1). Push piston into cylinder body by hand and push piston boots (2) piston-side lip into the piston groove.

CAUTION:

Press the pistons evenly and vary the pressing point to prevent cylinder inner wall from being rubbed.

5. Apply rubber grease to sliding pin boots, and install sliding pin boots to torque member.
6. Apply rubber grease to sliding pin, and install the cylinder body.
7. Install sliding pin bolts and tighten it to the specified torque. Refer to [BR-34, "BRAKE PAD : Exploded View"](#).

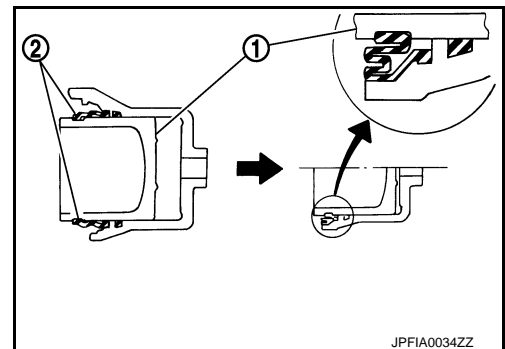

BRAKE CALIPER ASSEMBLY : Inspection

INFOID:000000009010915

INSPECTION AFTER DISASSEMBLY

Check the following items and replace if necessary.

Cylinder Body

Check the cylinder inner wall for rust, wear, cracks or damage.

CAUTION:

Always clean with new brake fluid. Never clean with mineral oil such as gasoline and light oil.

Torque Member

Check the torque member for rust, wear, cracks or damage.

Pistons

Check the surface of the piston for rust, wear, cracks or damage.

CAUTION:

A piston sliding surface is plated. Never polish with sandpaper.

Sliding Pin and Sliding Pin Boot

Check the sliding pins and sliding pin boots for rust, wear, cracks or damage.

INSPECTION AFTER INSTALLATION

1. Check a drag of front disc brake. If any drag is found, follow the procedure described below.
2. Remove brake pads. Refer to [BR-34, "BRAKE PAD : Removal and Installation"](#).

FRONT DISC BRAKE

< REMOVAL AND INSTALLATION >

3. Press the pistons. Refer to [BR-34, "BRAKE PAD : Removal and Installation"](#).
4. Install brake pads. Refer to [BR-34, "BRAKE PAD : Removal and Installation"](#).
5. Depress the brake pedal several times.
6. Check a drag of front disc brake again. If any drag is found, disassemble the caliper. Refer to [BR-38, "BRAKE CALIPER ASSEMBLY : Disassembly and Assembly"](#).
7. Burnish contact surfaces brake pads and disc rotor after refinishing or replacing disc rotor, or if a soft pedal occurs at very low mileage. Refer to [BR-16, "DISC ROTOR : Inspection and Adjustment"](#).

REAR DISC BRAKE

< REMOVAL AND INSTALLATION >

REAR DISC BRAKE

BRAKE PAD

BRAKE PAD : Exploded View

INFOID:000000009010916

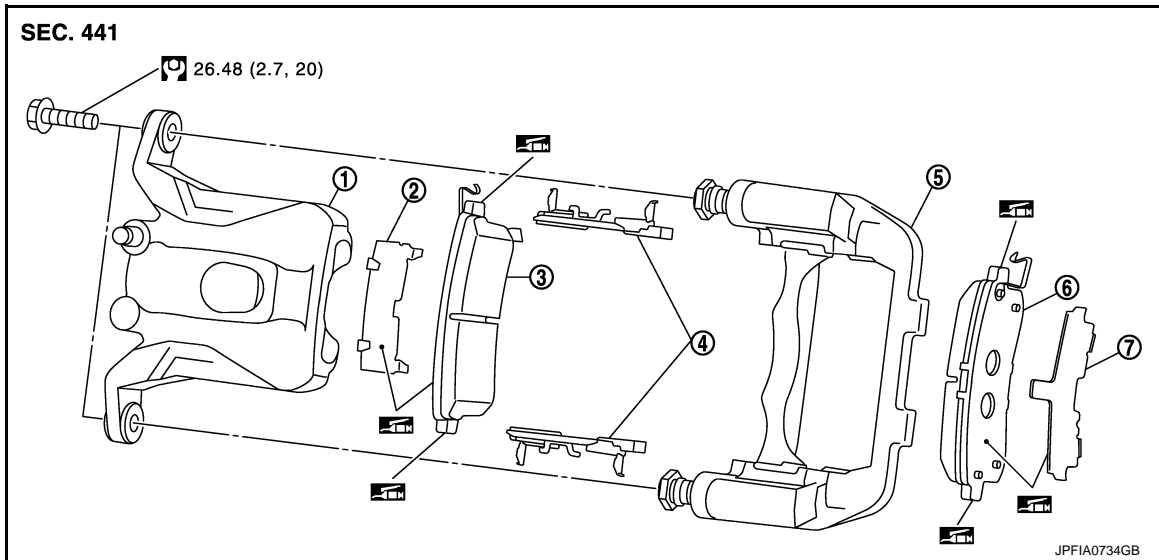

- | | | |
|------------------|------------------|-------------------------------------|
| 1. Cylinder body | 2. Inner shim | 3. Inner pad (with pad wear sensor) |
| 4. Pad retaining | 5. Torque member | 6. Outer pad |
| 7. Outer shim | | |

: Apply PBC (Poly Butyl Cuprysil) grease or silicone-based grease.

Refer to [GI-4, "Components"](#) for symbols not described on the above.

BRAKE PAD : Removal and Installation

INFOID:000000009010917

REMOVAL

WARNING:

Since dust covering the rear brake has an affect on human body, the dust must be removed with a dust collector. Never splatter the dust with an air blow gun.

CAUTION:

- Never depress the brake pedal while removing the brake pads because the piston may pop out.
- If the brake fluid or grease adheres to the brake caliper assembly and disc rotor, quickly wipe it off.

1. Remove tires with power tool.
2. Remove upper sliding pin bolt.
3. Suspend the cylinder body with suitable wire so that the brake hose will not stretch. Then remove the brake pads from the torque member.

CAUTION:

- Never deform the pad retainer when removing the pad retainer from the torque member.
- Never damage the piston boot.
- Never drop the brake pads and shims.
- Remember each position of the removed brake pads.

4. Perform inspection after removal. Refer to [BR-42, "BRAKE PAD : Inspection"](#).

INSTALLATION

WARNING:

Since dust covering the rear brake has an affect on human body, the dust must be removed with a dust collector. Never splatter the dust with an air blow gun.

CAUTION:

- Never depress the brake pedal while removing the brake pads because the piston may pop out.
- If the brake fluid or grease adheres to the brake caliper assembly and disc rotor, quickly wipe it off.

REAR DISC BRAKE

< REMOVAL AND INSTALLATION >

1. Install the torque member if the pad retainers has been removed.

CAUTION:

- Securely assemble the pad retainers so that it will not be lifted up from the torque member.
- Never deform the pad retainers.

2. Apply PCB (Poly Butyl Cuprysil) grease or silicone-based grease to the matching faces (A) between the brake pad and shim, and install the shims to brake pads.

CAUTION:

Always replace the shims when replacing the brake pad.

3. Apply PCB (Poly Butyl Cuprysil) grease or silicone-based grease to the matching faces (B) between the brake pad and torque member.

4. Install cylinder body to the torque member.

CAUTION:

- Never damage the piston boot.
- When replacing brake pad with new one, check a brake fluid level in the reservoir tank because brake fluid returns to reservoir tank when pressing piston in.

NOTE:

Use a disc brake piston tool to easily press piston.

5. Install the upper sliding pin bolt and tighten it to the specified torque.
6. Depress the brake pedal several times to check that no drag feel is present for the rear disc brake. Refer to [BR-42, "BRAKE PAD : Inspection"](#).
7. Install tires with power tool. Refer to [WT-63, "Exploded View"](#).

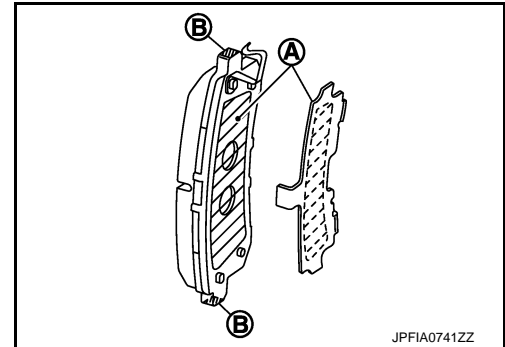

BRAKE PAD : Inspection

INFOID:000000009010918

INSPECTION AFTER REMOVAL

- Replace the shims if rust is excessively attached.
- Eliminate rust on the pad retainers and the torque member. Replace them if rust is excessively attached.

INSPECTION AFTER INSTALLATION

1. Check a drag of rear disc brake. If any drag is found, follow the procedure described below.
2. Remove brake pads. Refer to [BR-41, "BRAKE PAD : Removal and Installation"](#).
3. Press the piston. Refer to [BR-41, "BRAKE PAD : Removal and Installation"](#).
4. Install brake pads. Refer to [BR-41, "BRAKE PAD : Removal and Installation"](#).
5. Depress the brake pedal several times.
6. Check a drag of rear disc brake again. If any drag is found, disassemble the caliper. Refer to [BR-44, "BRAKE CALIPER ASSEMBLY : Disassembly and Assembly"](#).
7. Burnish contact surfaces brake pads and disc rotor after refinishing or replacing brake pads, or if a soft pedal occurs at very low mileage. Refer to [BR-18, "BRAKE PAD : Inspection and Adjustment"](#).

BRAKE CALIPER ASSEMBLY

BRAKE CALIPER ASSEMBLY : Exploded View

INFOID:000000009010919

REMOVAL

REAR DISC BRAKE

< REMOVAL AND INSTALLATION >

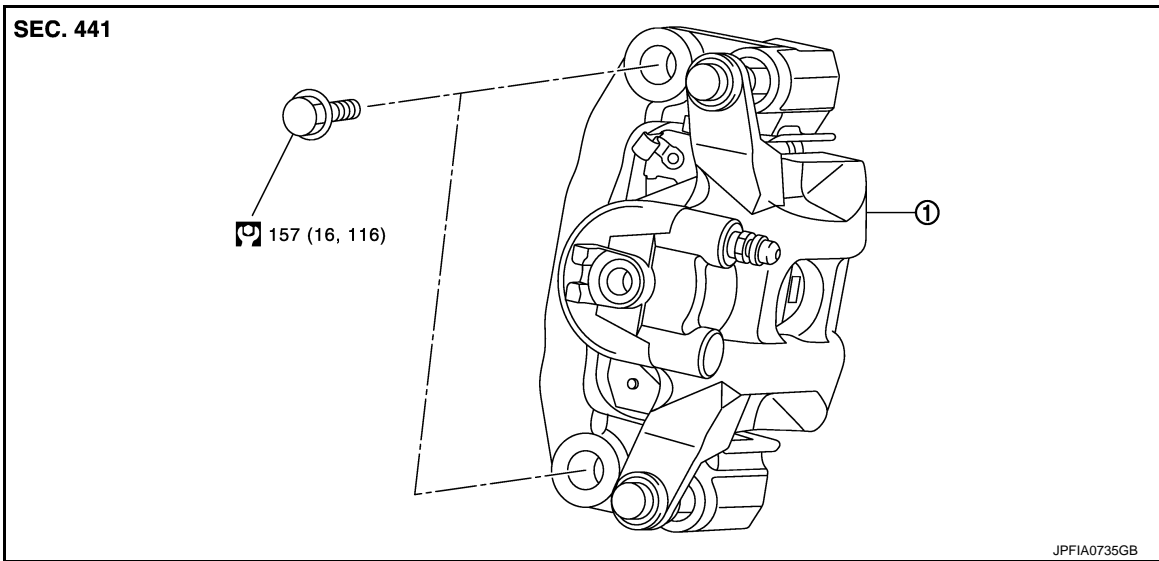

1. Brake caliper assembly

Refer to [GI-4, "Components"](#) for symbols in the figure.

DISASSEMBLY

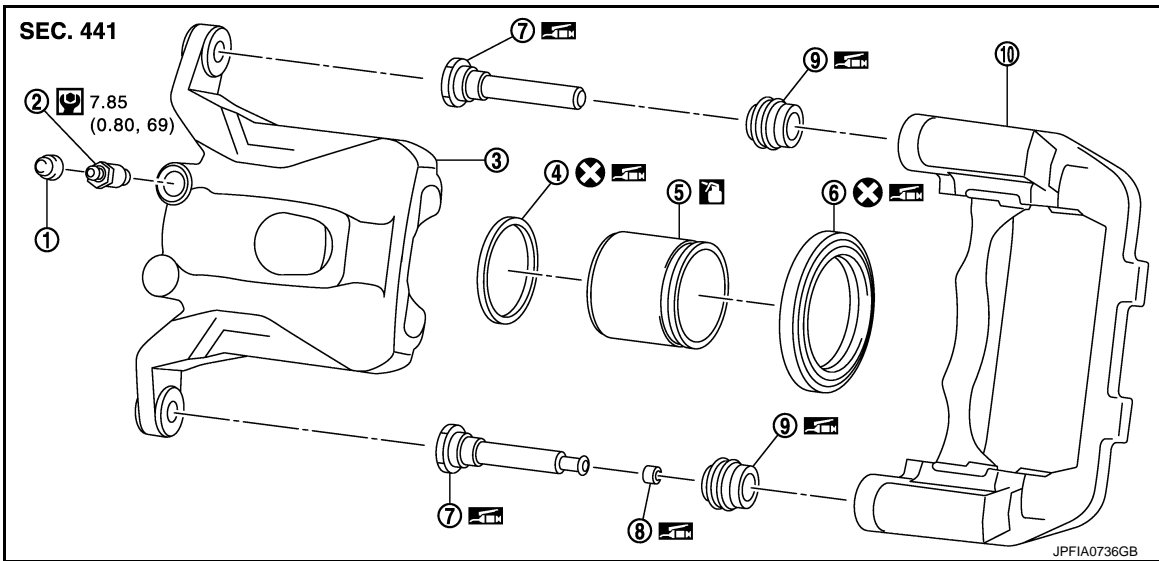

- | | | |
|-------------------|------------------|---------------------|
| 1. Cap | 2. Bleeder valve | 3. Cylinder body |
| 4. Piston seal | 5. Piston | 6. Piston boot |
| 7. Sliding pin | 8. Bushing | 9. Sliding pin boot |
| 10. Torque member | | |

: Apply rubber grease.

: Apply brake fluid

Refer to [GI-4, "Components"](#) for symbols not described on the above.

BRAKE CALIPER ASSEMBLY : Removal and Installation

INFOID:000000009010920

REMOVAL

WARNING:

Since dust covering the rear brake has an affect on human body, the dust must be removed with a dust collector. Never splatter the dust with an air blow gun.

REAR DISC BRAKE

< REMOVAL AND INSTALLATION >

CAUTION:

- Never spill or splash brake fluid on painted surfaces. Brake fluid may seriously damage paint. Wipe it off immediately and wash with water if it gets on a painted surface.
- Never depress the brake pedal. Brake fluid may splash while removing the brake hose.
- If the brake fluid or grease adheres to the brake caliper assembly and disc rotor, quickly wipe it off.

1. Remove tires with power tool.
2. Fix the disc rotor using wheel nuts.
3. Drain brake fluid. Refer to [BR-10, "Draining"](#).
4. Separate brake hose from brake caliper assembly. Refer to [BR-26, "REAR : Removal and Installation"](#).
5. Remove torque member mounting bolts, and remove brake caliper assembly.

CAUTION:

Never drop brake pad and caliper assembly.

6. Remove disc rotor. Refer to [RAX-7, "Removal and Installation"](#).

INSTALLATION

WARNING:

Since dust covering the rear brake has an affect on human body, the dust must be removed with a dust collector. Never splatter the dust with an air blow gun.

CAUTION:

- Never spill or splash brake fluid on painted surfaces. Brake fluid may seriously damage paint. Wipe it off immediately and wash with water if it gets on a painted surface.
- Never depress the brake pedal. Brake fluid may splash while removing the brake hose.
- If the brake fluid or grease adheres to the brake caliper assembly and disc rotor, quickly wipe it off.

1. Install disc rotor. Refer to [RAX-7, "Removal and Installation"](#).
2. Install the brake caliper assembly to the axle housing and tighten the torque member mounting bolts to the specified torque.

CAUTION:

Never spill or splash any grease and moisture on the brake caliper assembly mounting face, threads, mounting bolts. Wipe out any grease and moisture.

3. Install brake hose to brake caliper assembly. Refer to [BR-26, "REAR : Removal and Installation"](#).
4. Perform the air bleeding. Refer to [BR-11, "Bleeding Brake System"](#).
5. Check a drag of rear disc brake. If any drag is found, refer to [BR-45, "BRAKE CALIPER ASSEMBLY : Inspection"](#).
6. Install tires with power tool. Refer to [WT-63, "Exploded View"](#).

BRAKE CALIPER ASSEMBLY : Disassembly and Assembly

INFOID:000000009010921

DISASSEMBLY

NOTE:

Never remove the torque member, brake pads and pad retainers when disassembling and assembling the cylinder body.

1. Remove the sliding pin bolt, and remove the cylinder body from the torque member.

CAUTION:

Fix the brake pad at suitable tape so that the brake pad will not drop.

2. Remove sliding pin boots from torque member.
3. Remove bushing from sliding pin bolt.
4. Place a wooden block as shown in the figure, and blow air from brake hose mounting hole to remove piston and piston boot.

CAUTION:

Never get fingers caught in the piston.

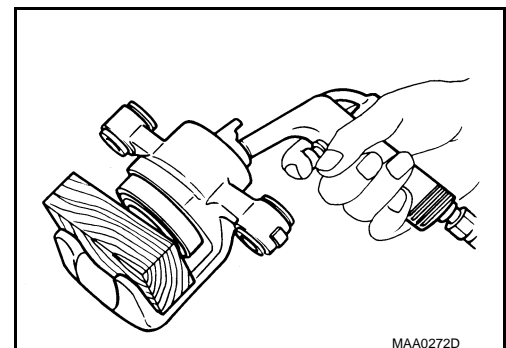

REAR DISC BRAKE

< REMOVAL AND INSTALLATION >

- Remove piston seal from cylinder body using suitable tool.
CAUTION:
Be careful not to damage a cylinder inner wall.
- Remove bleeder valve and cap.
- Perform inspection after disassembly. Refer to [BR-45, "BRAKE CALIPER ASSEMBLY : Inspection"](#).

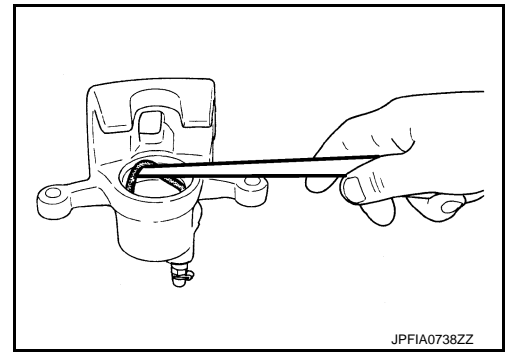

ASSEMBLY

- Install bleeder valve and cap.
- Apply rubber grease to piston seal (1), and install them to cylinder body.
CAUTION:
Never reuse piston seal.

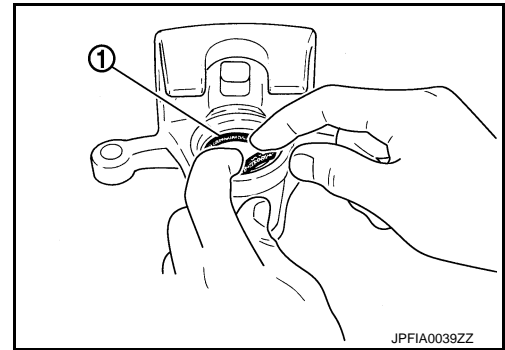

- Apply rubber grease to piston boot (1). Cover the piston (2) end with piston boot, and then install cylinder side lip on piston boot securely into a groove on cylinder body.
CAUTION:
Never reuse piston boot.

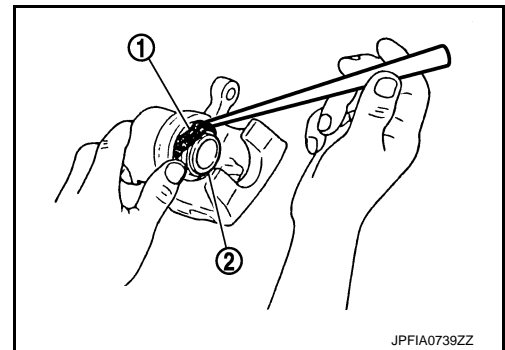

- Apply new brake fluid to piston (1). Push piston into cylinder body by hand and push piston boot (2) piston-side lip into the piston groove.
CAUTION:
Press the piston evenly and vary the pressing point to prevent cylinder inner wall from being rubbed.

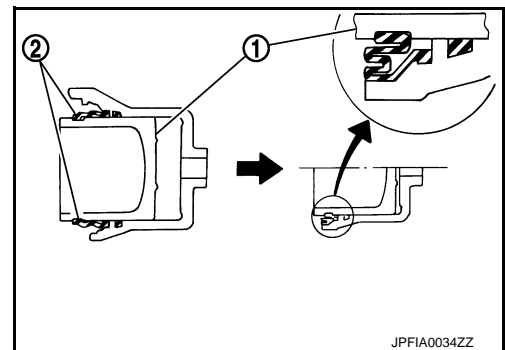

- Apply rubber grease to bushing, and install bushing to sliding pin bolt.
- Apply rubber grease to sliding pin boots, and install sliding pin boots to torque member.
- Apply rubber grease to sliding pin, and install the cylinder body.
- Install sliding pin bolts and tighten it to the specified torque. Refer to [BR-42, "BRAKE CALIPER ASSEMBLY : Exploded View"](#).

BRAKE CALIPER ASSEMBLY : Inspection

INFOID:000000009010922

INSPECTION AFTER DISASSEMBLY

Check the following items and replace if necessary.

Cylinder Body

Check the cylinder inner wall for rust, wear, cracks or damage.

REAR DISC BRAKE

< REMOVAL AND INSTALLATION >

CAUTION:

Always clean with new brake fluid. Never clean with mineral oil such as gasoline and light oil.

Torque Member

Check the torque member for rust, wear, cracks or damage.

Piston

Check the surface of the piston for rust, wear, cracks or damage.

CAUTION:

A piston sliding surface is plated. Never polish with sandpaper.

Sliding Pin, Sliding Pin Boot and Bushing

Check the sliding pins, sliding pin boots and bushing for rust, wear, cracks or damage.

INSPECTION AFTER INSTALLATION

1. Check a drag of rear disc brake. If any drag is found, follow the procedure described below.
2. Remove brake pads. Refer to [BR-41, "BRAKE PAD : Removal and Installation"](#).
3. Press the piston. Refer to [BR-41, "BRAKE PAD : Removal and Installation"](#).
4. Install brake pads. Refer to [BR-41, "BRAKE PAD : Removal and Installation"](#).
5. Depress the brake pedal several times.
6. Check a drag of rear disc brake again. If any drag is found, disassemble the caliper. Refer to [BR-44, "BRAKE CALIPER ASSEMBLY : Disassembly and Assembly"](#).
7. Burnish contact surfaces brake pads and disc rotor after refinishing or replacing disc rotor, or if a soft pedal occurs at very low mileage. Refer to [BR-18, "DISC ROTOR : Inspection and Adjustment"](#).

SERVICE DATA AND SPECIFICATIONS (SDS)

< SERVICE DATA AND SPECIFICATIONS (SDS)

SERVICE DATA AND SPECIFICATIONS (SDS)

SERVICE DATA AND SPECIFICATIONS (SDS)

General Specification

INFOID:000000009010923

Unit: mm (in)

Front brake	Cylinder bore diameter	50.8 (2.000) × 2
	Pad length × width × thickness	151.6 (5.97) × 56.5 (2.224) × 12.0 (0.472)
	Rotor outer diameter × thickness	350 (13.78) × 30.0 (1.181)
Rear brake	Cylinder bore diameter	48.1 (1.894)
	Pad length × width × thickness	110.0 (4.33) × 41.0 (1.614) × 9.0 (0.354)
	Rotor outer diameter × thickness	350 (13.78) × 20.0 (0.787)
Control valve	Valve type	Electric brake force distribution
Recommended brake fluid		Refer to MA-15, "FOR NORTH AMERICA : Fluids and Lubricants" (for North America), MA-16, "FOR MEXICO : Fluids and Lubricants" (for Mexico).

Brake Pedal

INFOID:000000009010924

Unit: mm (in)

Item	Standard
Brake pedal height	168.5 (6.63) – 178.5 (7.03)
Depressed brake pedal height [Depressing 490 N (50 kg, 110 lb) while turning the engine ON]	100 (3.94) or more
Clearance between stop lamp switch and brake switch threaded end and the brake pedal bracket	0.2 (0.008) – 1.96 (0.0772)
Brake pedal play	3 (0.12) – 11 (0.43)

Brake Booster

INFOID:000000009010925

Unit: mm (in)

Item	Standard
Input rod length	202.2 (7.96)

Front Disc Brake

INFOID:000000009010926

Unit: mm (in)

Item	Limit
Brake pad	Wear thickness 1.5 (0.059)
Disc rotor	Wear thickness 28.5 (1.122)
	Thickness variation (measured at 8 positions) 0.015 (0.0006)
	Runout (with it attached to the vehicle) 0.053 (0.0021)

Rear Disc Brake

INFOID:000000009010927

Unit: mm (in)

Item	Limit
Brake pad	Wear thickness 2.0 (0.079)
Disc rotor	Wear thickness 18.0 (0.709)
	Thickness variation (measured at 8 positions) 0.015 (0.0006)
	Runout (with it attached to the vehicle) 0.05 (0.0020)