

CONTENTS

PRECAUTION	2	RADIATOR	12	A
PRECAUTIONS	2	RADIATOR : Inspection	12	
Precautions for Removing of Battery Terminal	2	REMOVAL AND INSTALLATION	14	CO
Precaution for Supplemental Restraint System (SRS) "AIR BAG" and "SEAT BELT PRE-TENSIONER"	2	RADIATOR	14	
PREPARATION	3	Exploded View	14	
PREPARATION	3	Removal and Installation	14	
Commercial Service Tools	3	Inspection	17	
SYSTEM DESCRIPTION	4	COOLING FAN	18	
DESCRIPTION	4	Exploded View	18	
Engine Cooling System	4	Removal and Installation	18	
Engine Cooling System Schematic	5	Inspection	19	
SYMPTOM DIAGNOSIS	6	WATER PUMP	20	
OVERHEATING CAUSE ANALYSIS	6	Exploded View	20	
Troubleshooting Chart	6	Removal and Installation	20	
PERIODIC MAINTENANCE	8	Inspection	21	
ENGINE COOLANT	8	WATER INLET AND THERMOSTAT ASSEMBLY	22	
Inspection	8	Exploded View	22	
Draining	8	Removal and Installation	22	
Refilling	9	Inspection	23	
Flushing	10	SERVICE DATA AND SPECIFICATIONS (SDS)	25	
RADIATOR	12	SERVICE DATA AND SPECIFICATIONS (SDS)	25	
RESERVOIR TANK CAP	12	Periodical Maintenance Specification	25	
RESERVOIR TANK CAP : Inspection	12	Radiator	25	
		Thermostat	25	

CO

C

D

E

F

G

H

I

J

K

L

M

N

O

P

PRECAUTIONS

< PRECAUTION >

PRECAUTION

PRECAUTIONS

Precautions for Removing of Battery Terminal

INFOID:000000009864645

- When removing the 12V battery terminal, turn OFF the ignition switch and wait at least 30 seconds.

NOTE:

ECU may be active for several tens of seconds after the ignition switch is turned OFF. If the battery terminal is removed before ECU stops, then a DTC detection error or ECU data corruption may occur.

- For vehicles with the 2-batteries, be sure to connect the main battery and the sub battery before turning ON the ignition switch.

NOTE:

If the ignition switch is turned ON with any one of the terminals of main battery and sub battery disconnected, then DTC may be detected.

- After installing the 12V battery, always check "Self Diagnosis Result" of all ECUs and erase DTC.

NOTE:

The removal of 12V battery may cause a DTC detection error.

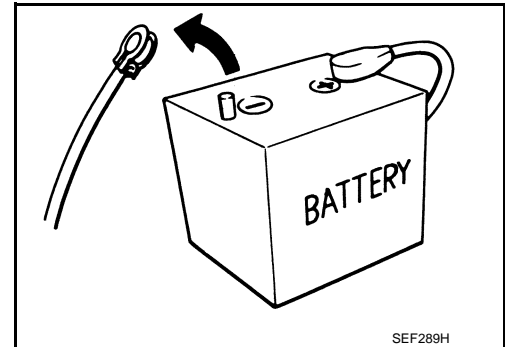

Precaution for Supplemental Restraint System (SRS) "AIR BAG" and "SEAT BELT PRE-TENSIONER"

INFOID:000000009010928

The Supplemental Restraint System such as "AIR BAG" and "SEAT BELT PRE-TENSIONER", used along with a front seat belt, helps to reduce the risk or severity of injury to the driver and front passenger for certain types of collision. Information necessary to service the system safely is included in the "SRS AIR BAG" and "SEAT BELT" of this Service Manual.

WARNING:

Always observe the following items for preventing accidental activation.

- To avoid rendering the SRS inoperative, which could increase the risk of personal injury or death in the event of a collision that would result in air bag inflation, all maintenance must be performed by an authorized NISSAN/INFINITI dealer.
- Improper maintenance, including incorrect removal and installation of the SRS, can lead to personal injury caused by unintentional activation of the system. For removal of Spiral Cable and Air Bag Module, see "SRS AIR BAG".
- Never use electrical test equipment on any circuit related to the SRS unless instructed to in this Service Manual. SRS wiring harnesses can be identified by yellow and/or orange harnesses or harness connectors.

PRECAUTIONS WHEN USING POWER TOOLS (AIR OR ELECTRIC) AND HAMMERS

WARNING:

Always observe the following items for preventing accidental activation.

- When working near the Air Bag Diagnosis Sensor Unit or other Air Bag System sensors with the ignition ON or engine running, never use air or electric power tools or strike near the sensor(s) with a hammer. Heavy vibration could activate the sensor(s) and deploy the air bag(s), possibly causing serious injury.
- When using air or electric power tools or hammers, always switch the ignition OFF, disconnect the battery, and wait at least 3 minutes before performing any service.

PREPARATION

< PREPARATION >

PREPARATION

PREPARATION

Commercial Service Tools

INFOID:000000009010929

A

CO

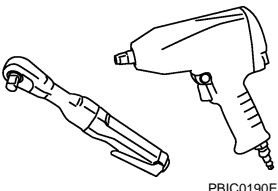
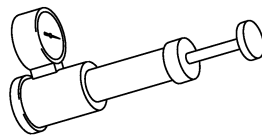
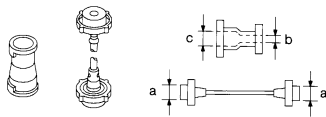
Tool name	Description
<p>Power tool</p>  <p>PBI0190E</p>	<p>Loosening bolts and nuts</p>
<p>Radiator cap tester</p>  <p>PBIC1982E</p>	<p>Checking radiator and radiator cap (reservoir tank cap)</p>
<p>Radiator cap tester adapter</p>  <p>S-NT564</p>	<p>Adapting radiator cap tester to radiator cap (reservoir tank cap) and water inlet filler neck a: 28 (1.10) dia. b: 31.4 (1.236) dia. c: 41.3 (1.626) dia. Unit: mm (in)</p>

C

D

E

F

G

H

I

J

K

L

M

N

O

P

DESCRIPTION

< SYSTEM DESCRIPTION >

SYSTEM DESCRIPTION

DESCRIPTION

Engine Cooling System

INFOID:000000009010930

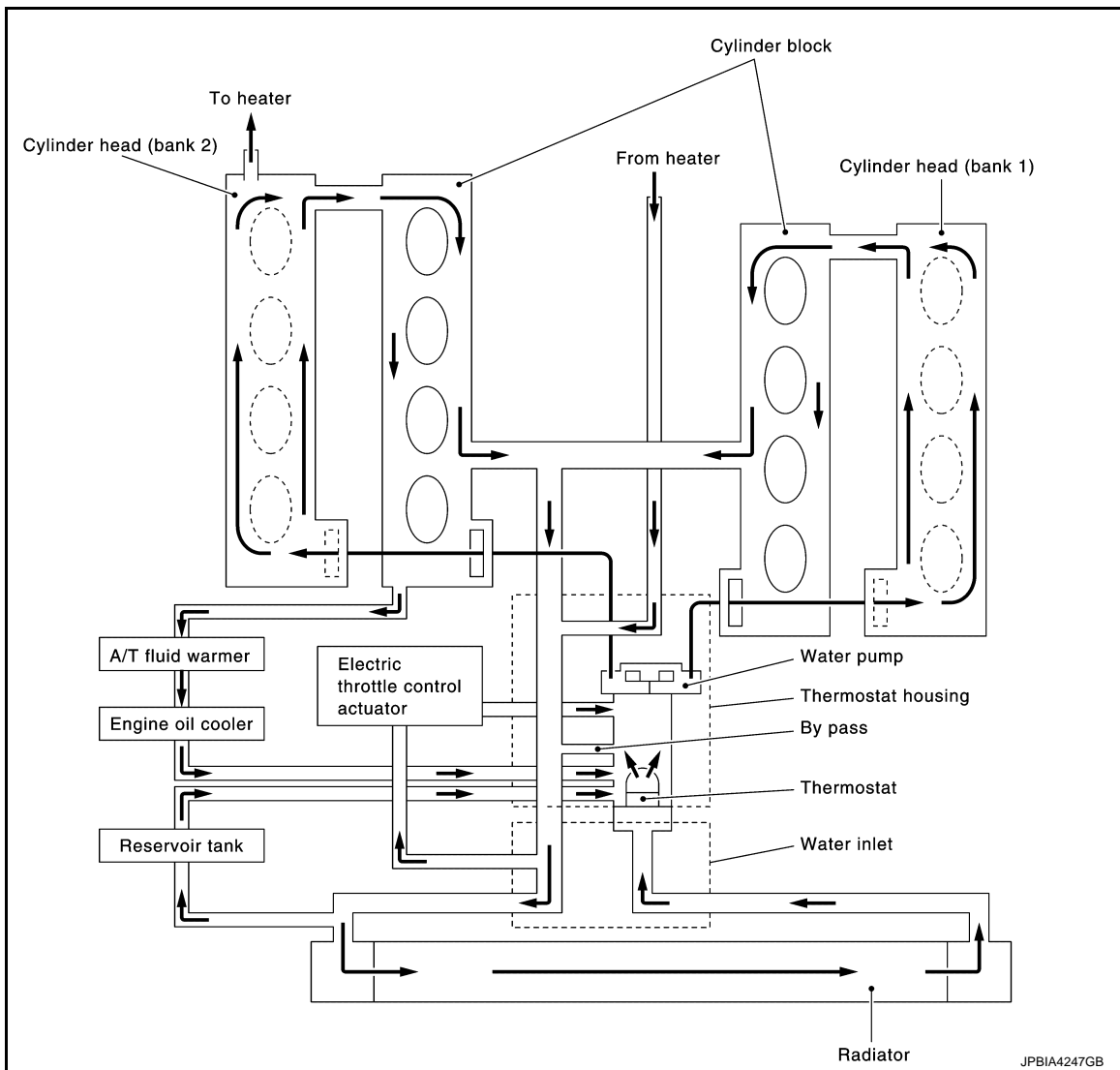

DESCRIPTION

< SYSTEM DESCRIPTION >

Engine Cooling System Schematic

INFOID:000000009010931

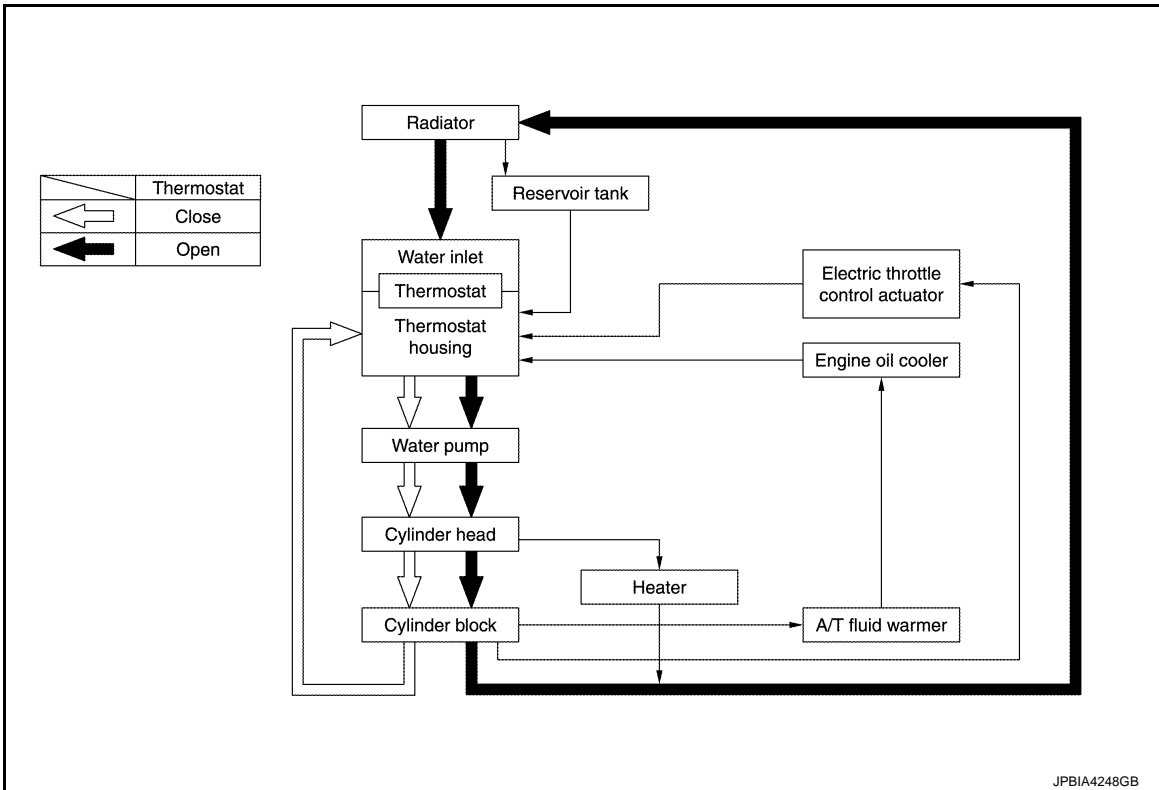

JPBIA4248GB

A
CO
C
D
E
F
G
H
I
J
K
L
M
N
O
P

OVERHEATING CAUSE ANALYSIS

< SYMPTOM DIAGNOSIS >

SYMPTOM DIAGNOSIS

OVERHEATING CAUSE ANALYSIS

Troubleshooting Chart

INFOID:000000009010932

		Symptom	Check items	
Cooling system parts malfunction	Poor heat transfer	Water pump malfunction	Worn or loose drive belt	—
		Thermostat stuck closed	—	
		Damaged fins	Dust contamination or paper clogging	
			Physical damage	
		Clogged radiator cooling tube	Excess foreign material (rust, dirt, sand, etc.)	
	Reduced air flow	Cooling fan does not operate	Fan assembly	—
		High resistance to fan rotation		
		Damaged fan blades		
		Damaged radiator shroud	—	—
		Improper engine coolant mixture ratio	—	—
		Poor engine coolant quality	—	Engine coolant density
	Insufficient engine coolant	Engine coolant leakage	Cooling hose	Loose clamp
				Cracked hose
			Water pump	Poor sealing
			Radiator cap	Loose
Poor sealing				
Radiator			O-ring for damage, deterioration or improper fitting	
		Cracked radiator tank		
		Cracked radiator core		
		Reservoir tank	Cracked reservoir tank	
Overflowing reservoir tank	Exhaust gas leakage into cooling system	Cylinder head deterioration		
		Cylinder head gasket deterioration		

OVERHEATING CAUSE ANALYSIS

< SYMPTOM DIAGNOSIS >

	Symptom		Check items				
Except cooling system parts malfunction	—	Overload on engine	Abusive driving	High engine rpm under no load	A		
				Driving in low gear for extended time	CO		
				Driving at extremely high speed			
					Powertrain system malfunction		C
					Installed improper size wheels and tires	—	D
					Dragging brakes		
			Improper ignition timing		E		
	Blocked or restricted air flow		Blocked bumper	—		E	
		Blocked radiator grille		Installed car brassiere			
				Mud contamination or paper clogging	—	F	
			Blocked radiator	—			
			Blocked condenser			G	
	Installed large fog lamp	Blocked air flow					

A
CO
C
D
E
F
G
H
I
J
K
L
M
N
O
P

ENGINE COOLANT

< PERIODIC MAINTENANCE >

PERIODIC MAINTENANCE

ENGINE COOLANT

Inspection

INFOID:000000009010933

LEVEL

- Check if the reservoir tank engine coolant level is within the “MIN” to “MAX” when the engine is cool.

A : MAX
B : MIN

- Adjust the engine coolant level if necessary.

WARNING:

Never remove reservoir tank cap when engine is hot.

CAUTION:

Refill Genuine NISSAN Long Life Antifreeze/Coolant (blue) or equivalent in its quality mixed with water (distilled or demineralized). Refer to the following table:

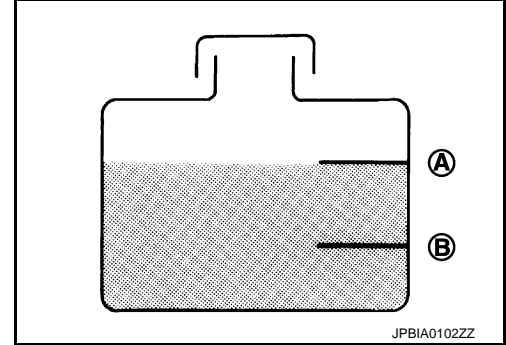

For NORTH AMERICA	MA-15. "FOR NORTH AMERICA : Fluids and Lubricants"
For MEXICO	MA-16. "FOR MEXICO : Fluids and Lubricants"

LEAKAGE

- To check for leakage, apply pressure to the cooling system with the radiator cap tester and radiator cap tester adapter (commercial service tool) (A).

Testing pressure : Refer to [CO-25. "Radiator"](#).

WARNING:

Never remove radiator cap and reservoir tank cap when engine is hot. Serious burns could occur from high-pressure engine coolant escaping from water inlet.

CAUTION:

Higher test pressure than specified may cause radiator damage.

NOTE:

In a case that engine coolant decreases, fill radiator with engine coolant.

- If anything is found, repair or replace damaged parts.

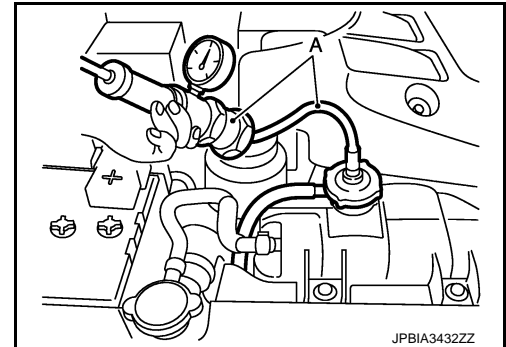

Draining

INFOID:000000009010934

WARNING:

- Never remove radiator cap and reservoir tank cap when engine is hot. Serious burns could occur from high-pressure engine coolant escaping from radiator.
- Wrap a thick cloth around the caps. Slowly turn them a quarter of a turn to release built-up pressure. Carefully remove the caps by turning it all the way.

ENGINE COOLANT

< PERIODIC MAINTENANCE >

1. Open radiator drain plug (1) at the bottom of radiator, and then remove radiator cap and reservoir tank cap.

2 : Front under cover

↔ : Vehicle front

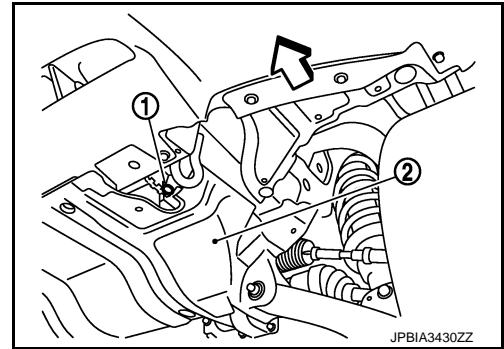

When draining all of engine coolant in the system, open water drain plug on cylinder block. Refer to [EM-109, "Setting"](#).

2. Remove reservoir tank if necessary, and drain engine coolant and clean reservoir tank before installing.
3. Check drained engine coolant for contaminants such as rust, corrosion or discoloration. If contaminated, flush the engine cooling system. Refer to [CO-10, "Flushing"](#).

Refilling

INFOID:000000009010935

CAUTION:

- Do not reuse O-rings.
- Do not put additive such as waterleak preventive, since it may cause cooling waterway clogging.
- When refilling use Genuine NISSAN Long Life Antifreeze/Coolant (blue) or equivalent in its quality mixed with water (distilled or demineralized). Refer to the following table:

For NORTH AMERICA	MA-15, "FOR NORTH AMERICA : Fluids and Lubricants"
For MEXICO	MA-16, "FOR MEXICO : Fluids and Lubricants"

1. Install reservoir tank if removed, and radiator drain plug.

CAUTION:

Be sure to clean drain plug and install with new O-ring. Refer to [CO-14, "Exploded View"](#).

 : 1.96 N-m (0.2 kg-m, 17 in-lb)

If water drain plug on cylinder block is removed, close and tighten it. Refer to [EM-116, "Disassembly and Assembly"](#).

2. Check that each hose clamp is firmly tightened.
3. Remove air relief plug (1) on heater hose.

2. Engine cover

↔ : Vehicle front

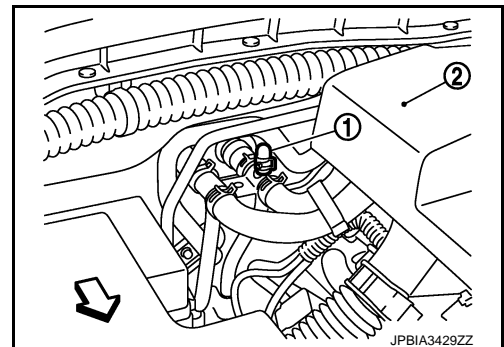

ENGINE COOLANT

< PERIODIC MAINTENANCE >

4. Fill radiator, and reservoir tank, to specified level.
 - Pour engine coolant through engine coolant filler neck slowly of less than 3 ℓ (2-5/8 Imp qt) a minute to allow air in system to escape.

Engine coolant capacity (With reservoir tank at "MAX" level) : Refer to [CO-25, "Periodical Maintenance Specification"](#).

Reservoir tank engine coolant capacity (At "MAX" level) : Refer to [CO-25, "Periodical Maintenance Specification"](#).

A : MAX

B : MIN

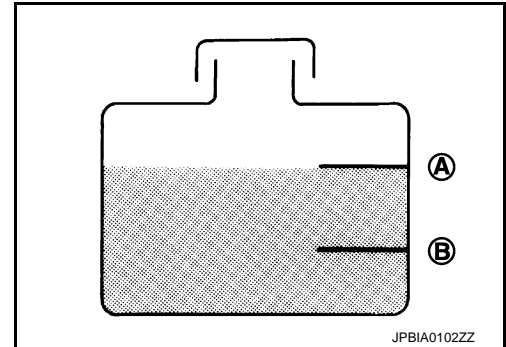
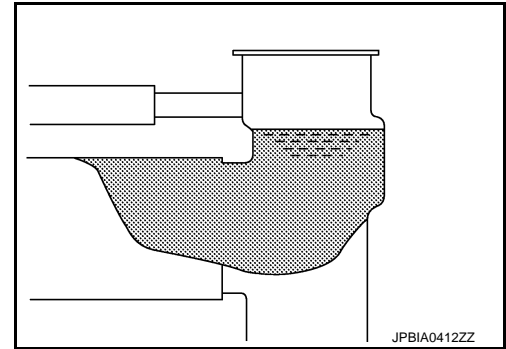

5. When engine coolant overflows air relief hole on heater hose, install air relief plug with clamp. Then refill radiator with engine coolant.
6. Install radiator cap.
7. Install reservoir tank cap.
8. Warm up engine until opening thermostat less than 3,000 rpm.
 - Check thermostat opening condition by touching radiator hose (lower) to see a flow of warm water.

CAUTION:
Watch water temperature gauge so as not to overheat engine.
9. Stop the engine and cool down to less than approximately 50°C (122°F).
 - Cool down using fan to reduce the time.
 - If necessary, refill radiator up to filler neck with engine coolant.
10. Refill reservoir tank to "MAX" level line with engine coolant if necessary.
11. Repeat steps 6 through 10 two or more times with reservoir tank cap installed until engine coolant level no longer drops.
12. Check cooling system for leakage with engine running.
13. Warm up the engine, and check for sound of engine coolant flow while running engine from idle up to 3,000 rpm with heater temperature controller set at several position between "COOL" and "WARM".
 - Sound may be noticeable at heater unit.
14. Repeat step 13 three times.
15. If sound is heard, bleed air from cooling system by repeating step 4, and steps from 6 to 14 until engine coolant level no longer drops.

Flushing

INFOID:000000009010936

1. Install reservoir tank if removed, and radiator drain plug.

CAUTION:

Be sure to clean drain plug and install with new O-ring. Refer to [CO-14, "Exploded View"](#).

 : 1.96 N·m (0.2 kg·m, 17 in·lb)

If water drain plug on cylinder block is removed, close and tighten it. Refer to [EM-116, "Disassembly and Assembly"](#).

ENGINE COOLANT

< PERIODIC MAINTENANCE >

2. Remove air relief plug (1) on heater hose.

- 2. Engine cover
- ⇐ : Vehicle front

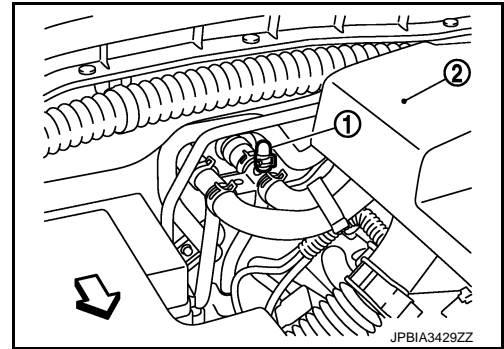

- 3. Fill radiator and reservoir tank with water until water spills from the air relief holes, then close air relief plugs with clamp. Fill radiator and reservoir tank with water and reinstall caps.
- 4. Run the engine and warm it up to normal operating temperature.
- 5. Rev the engine two or three times under no-load.
- 6. Stop the engine and wait until it cools down.
- 7. Drain water from the system. Refer to [CO-8, "Draining"](#).
- 8. Repeat steps 1 through 7 until clear water begins to drain from radiator.

A
CO
C
D
E
F
G
H
I
J
K
L
M
N
O
P

RADIATOR

< PERIODIC MAINTENANCE >

RADIATOR

RESERVOIR TANK CAP

RESERVOIR TANK CAP : Inspection

INFOID:000000009010937

- Check valve seat of reservoir tank cap.
- Check if valve seat (A) is swollen to the extent that the edge of the metal plunger (B) cannot be seen when watching it vertically from the top.
- Check if valve seat has no soil and damage.

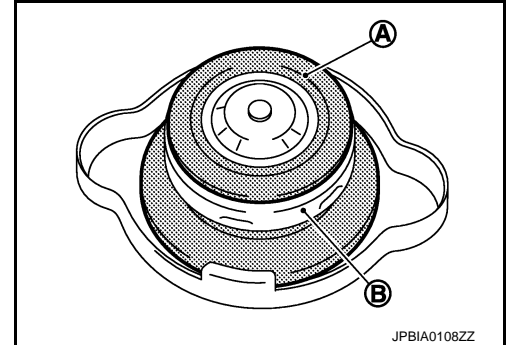

- Pull negative-pressure valve to open it, and check that it close completely when released.
- Check that there is no dirt or damage on the valve seat of reservoir tank cap negative-pressure valve.
- Check that there are no unusualness in the opening and closing conditions of negative-pressure valve.

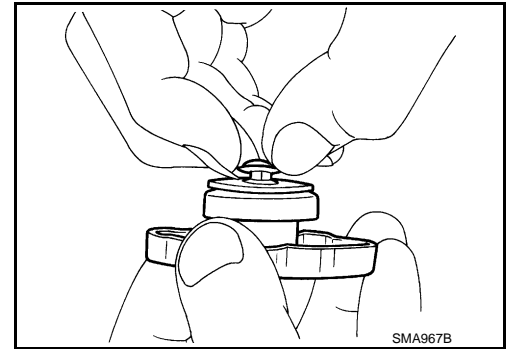

- Check reservoir tank cap relief pressure.
- When connecting reservoir tank cap to the radiator cap tester (commercial service tool) and the radiator cap tester adapter (commercial service tool) (A), apply engine coolant to the cap seal surface.

Standard and limit : Refer to [CO-25, "Radiator"](#).

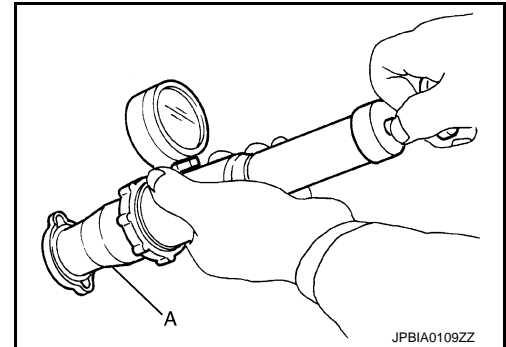

- Replace reservoir tank cap if there is an unusualness related to the above three.

CAUTION:

When installing reservoir tank cap, thoroughly wipe out the water inlet filler neck to remove any waxy residue or foreign material.

RADIATOR

RADIATOR : Inspection

INFOID:000000009010938

Check radiator for mud or clogging. If necessary, clean radiator as per the following:

- Be careful not to bend or damage radiator fins.
 - When radiator is cleaned without removal, remove all surrounding parts such as radiator cooling fan shroud. Then tape harness and connectors to prevent water from entering.
1. Apply water by hose to the back side of the radiator core vertically downward.
 2. Apply water again to all radiator core surfaces once per minute.

RADIATOR

< PERIODIC MAINTENANCE >

3. Stop washing if any stains no longer flow out from radiator.
4. Blow air into the back side of radiator core vertically downward.
 - Use compressed air lower than 490 kPa (5 kg/cm², 71 psi) and keep distance more than 30 cm (11.8 in).
5. Blow air again into all the radiator core surfaces once per minute until no water sprays out.

A

CO

C

D

E

F

G

H

I

J

K

L

M

N

O

P

RADIATOR

< REMOVAL AND INSTALLATION >

REMOVAL AND INSTALLATION

RADIATOR

Exploded View

INFOID:000000009010939

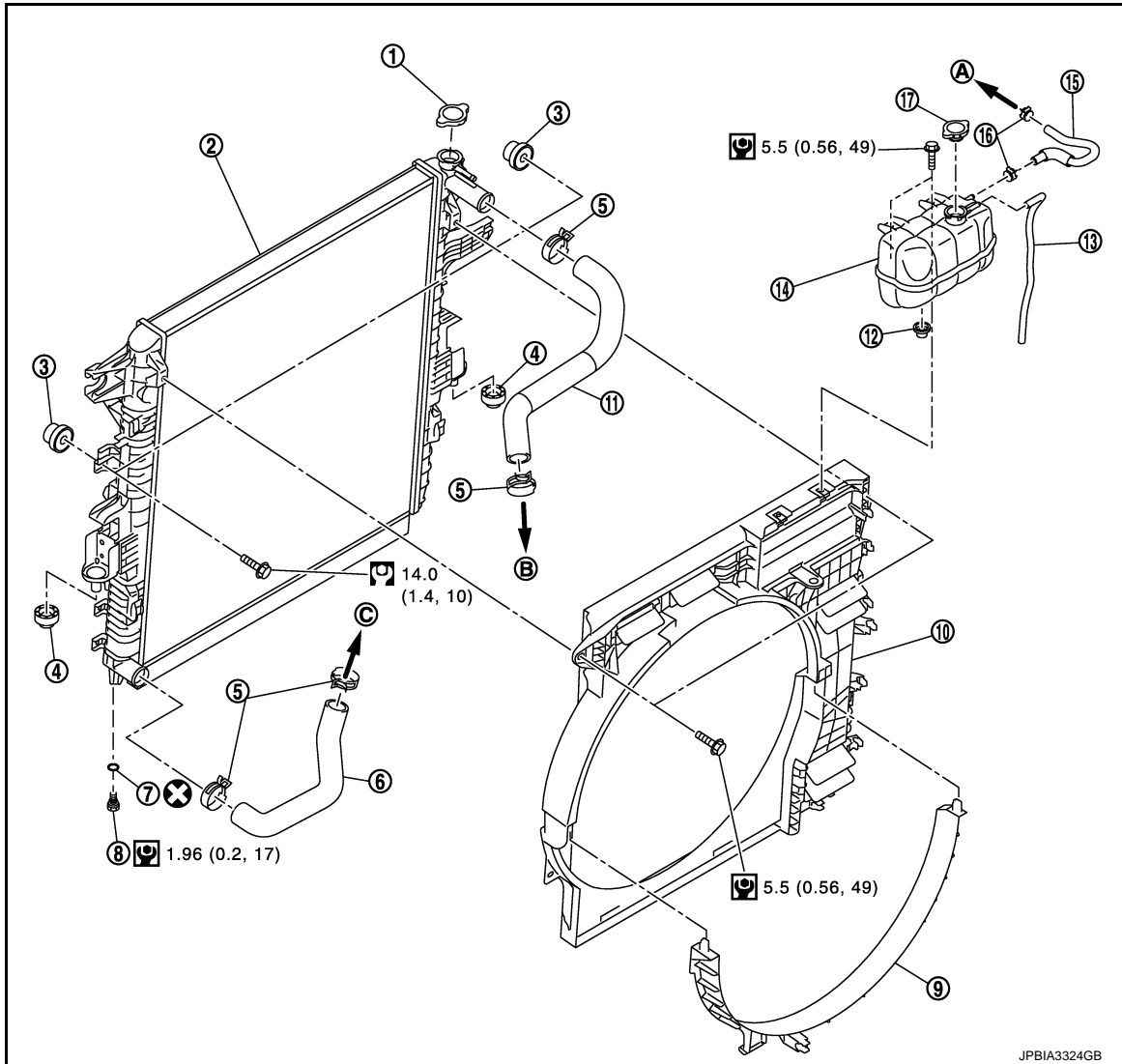

- | | | |
|----------------------------|---------------------------|-----------------------------|
| 1. Radiator cap | 2. Radiator | 3. Mounting rubber (upper) |
| 4. Mounting rubber (lower) | 5. Clamp | 6. Radiator hose (lower) |
| 7. O-ring | 8. Drain plug | 9. Fan shroud (lower) |
| 10. Fan shroud (upper) | 11. Radiator hose (upper) | 12. Mounting rubber (lower) |
| 13. Reservoir tank hose | 14. Reservoir tank | 15. Reservoir tank hose |
| 16. Clamp | 17. Reservoir tank cap | |
| A. To radiator | B. To water outlet | C. To water inlet |

Refer to [GI-4, "Components"](#) for symbols in the figure.

Removal and Installation

INFOID:000000009010940

REMOVAL

WARNING:

Never remove radiator cap when engine is hot. Serious burns could occur from high-pressure engine coolant escaping from water inlet. Wrap a thick cloth around the cap. Slowly turn it a quarter of a turn

RADIATOR

< REMOVAL AND INSTALLATION >

to release built-up pressure. Carefully remove radiator cap by turning it all the way. Note that the reservoir tank cap side is also under pressure.

NOTE:

When removing components such as hoses, tube/lines, etc., cap or plug openings to prevent fluid from spilling.

1. Remove front under cover with power tool. Refer to [EXT-26, "Exploded View"](#).
2. Remove engine cover. Refer to [EM-26, "Exploded View"](#).
3. Drain engine coolant from radiator. Refer to [CO-8, "Draining"](#).

CAUTION:

- Perform this step when the engine is cold.
- Never spill engine coolant on drive belts.

4. Remove radiator hose (lower).
5. Remove fan shroud (lower). Refer to [CO-14, "Exploded View"](#).
6. Move reservoir tank to the position without the hindrance for work.
7. Remove radiator core support cover. Refer to [DLK-226, "Exploded View"](#).
8. Remove fan shroud (upper), refer to following.
 - a. Remove EVAP hose mounting bolts and move harness to aside.
 - b. Move air cleaner case to the position without the hindrance for work. Refer to [EM-28, "Exploded View"](#).

NOTE:

The air cleaner case connector is not required to be disconnected.

9. Remove radiator grille. Refer to [EXT-20, "Exploded View"](#).
10. Move condenser to the position without the hindrance for work with the following procedures. Refer to [HA-39, "Exploded View"](#).
 - Remove mounting bolts and disconnect A/C piping from radiator.
 - Remove air guide from radiator. Refer to [EXT-12, "Exploded View"](#).
 - Remove radiator mounting bolts.
11. Remove radiator hose (upper).
12. Remove radiator as per the following:

CAUTION:

Be careful not to damage radiator core.

- Lift up and pull the radiator (1) forward, and then remove the mounting rubber (lower) (3) from the radiator core support (2).

← : Vehicle front

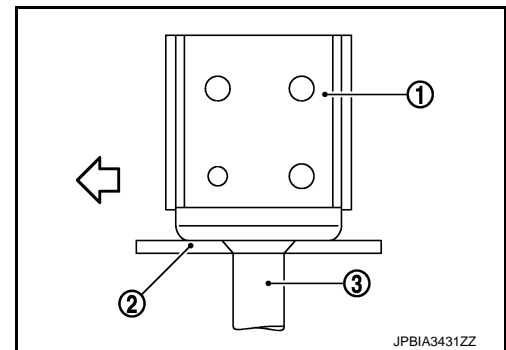

INSTALLATION

Note the following, and install in the reverse order of removal.

CAUTION:

- Do not reuse O-rings.
- Use genuine mounting bolts for the cooling fan assembly and strictly observe the tightening torque. (Breakage prevention for radiator)

NOTE:

- Insert the radiator hose (1) all the way to the stopper (2) or by 33 mm (1.30 in) (hose without a stopper).

RADIATOR

< REMOVAL AND INSTALLATION >

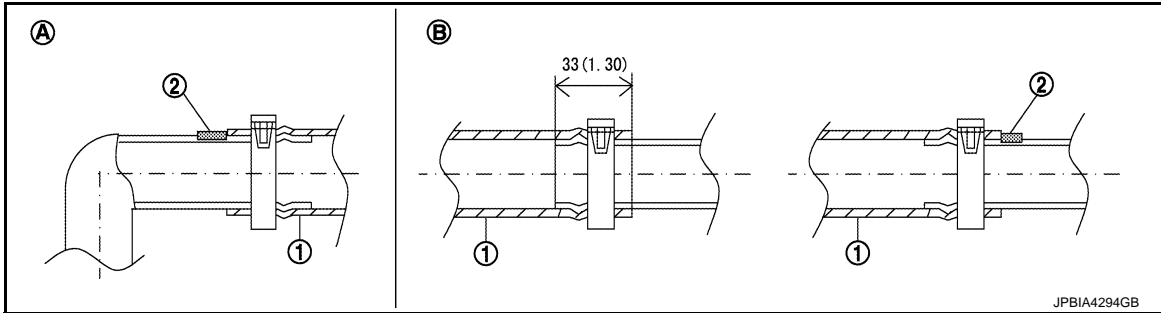

Unit mm (in)

A. Radiator side

B. Engine side

- For the orientation of the hose clamp pawl, refer to the figure.

Radiator hose	Hose end	Paint mark	Position of hose clamp*
Radiator hose (upper)	Radiator side	Upper	A
	Engine side	Upper	B
Radiator hose (lower)	Radiator side	Lower	C
	Engine side	Left side	D

*Refer to the illustrations for the specific position each hose clamp tab.

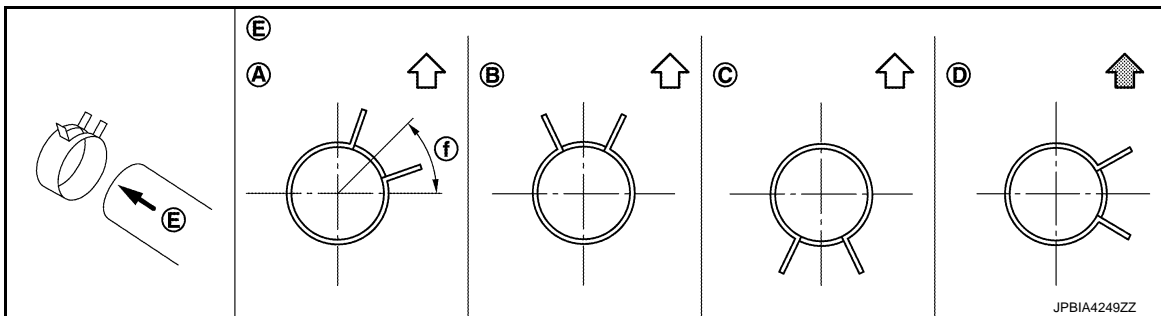

E. View E

f. 45°

↖ : Vehicle upper

↖ : Vehicle front

- The angle (b) created by the hose clamp pawl and the specified line (A) must be within $\pm 15^\circ$ as shown in the figure.

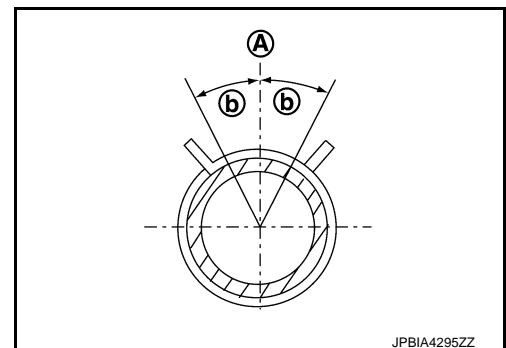

RADIATOR

< REMOVAL AND INSTALLATION >

- To install hose clamps (1), check that the dimension (A) from the end of the paint mark (2) on the radiator hose to the hose clamp is within the reference value.

Dimension "A"

**: (-1) – (+1) mm
(-0.04) – (+0.04) in**

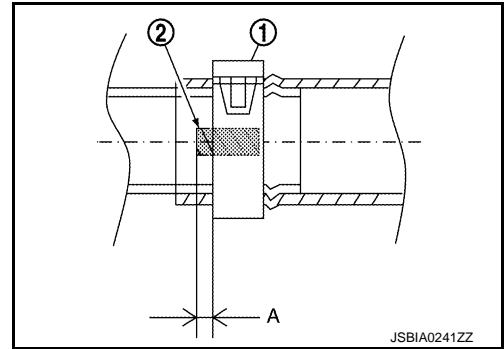

Inspection

INFOID:000000009010941

INSPECTION AFTER INSTALLATION

- Check for leakage of engine coolant using the radiator cap tester adapter (commercial service tool) and the radiator cap tester (commercial service tool). Refer to [CO-8, "Inspection"](#).
- Start and warm up the engine. Visually check that there is no leakage of engine coolant.

A
CO
C
D
E
F
G
H
I
J
K
L
M
N
O
P

COOLING FAN

< REMOVAL AND INSTALLATION >

COOLING FAN

Exploded View

INFOID:000000009010942

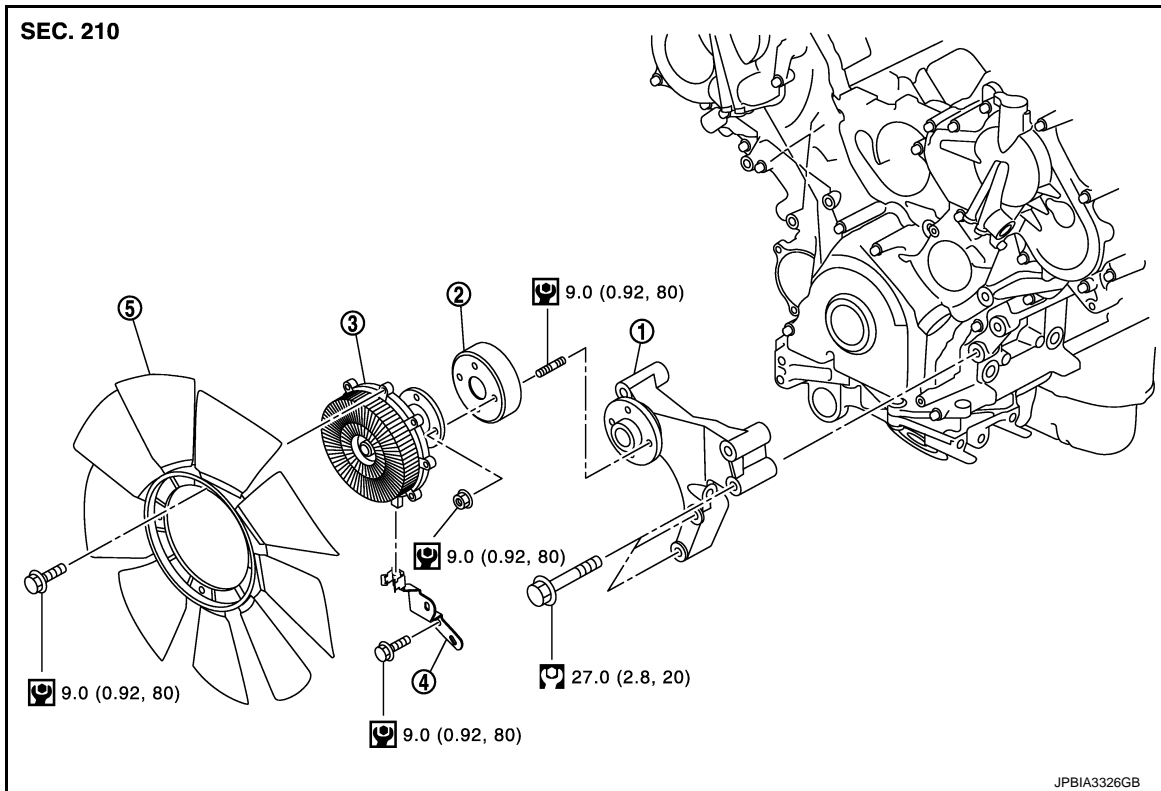

- | | | |
|----------------|-----------------------|-----------------|
| 1. Fan bracket | 2. Cooling fan pulley | 3. Fan coupling |
| 4. Bracket | 5. Cooling fan | |

Refer to [GI-4, "Components"](#) for symbols not described on the above.

Removal and Installation

INFOID:000000009010943

REMOVAL

1. Remove front under cover with power tool. Refer to [EXT-26, "Exploded View"](#).
2. Remove fan shroud (lower). Refer to [CO-14, "Exploded View"](#).
3. Move reservoir tank to the position without the hindrance for work, refer to following.
 - Remove fixed bolts
 - Remove reservoir tank hose clamp.
4. Remove radiator core support cover. Refer to [DLK-226, "Exploded View"](#).
5. Remove fan shroud (upper), refer to following.
 - Remove EVAP hose.
 - Remove fan shroud (upper) mounting bolts. Refer to [CO-14, "Exploded View"](#).
 - Move air cleaner to the position without the hindrance for work.
 - Remove engine cover. Refer to [EM-26, "Exploded View"](#).
6. Remove cooling fan.
7. Remove drive belt. Refer to [EM-20, "Exploded View"](#).
8. Disconnect fan coupling harness connector.
9. Remove fan coupling.
10. Remove bracket.
11. Remove cooling fan pulley.
12. Remove Idler pulley.

COOLING FAN

< REMOVAL AND INSTALLATION >

13. Remove the fan bracket, refer to following.

- Disconnect A/C compressor harness connector. Refer to [HA-30, "Exploded View"](#).
- Remove A/C compressor mounting bolt. Refer to [HA-30, "Exploded View"](#).
- Remove fan bracket mounting bolt.

INSTALLATION

Installation is in the reverse order of removal.

Inspection

INFOID:000000009010944

INSPECTION AFTER REMOVAL

Fan Coupling

Inspect fan coupling for oil leakage and bimetal conditions.

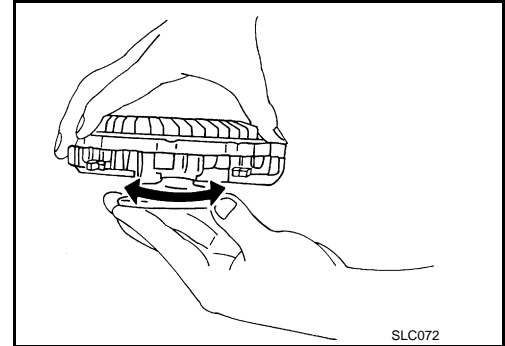

Fan Bracket

- Visually check that there is no significant looseness in the fan bracket shaft, and that it turns smoothly by hand.
- If there are any unusual concerns, replace the cooling fan pulley.

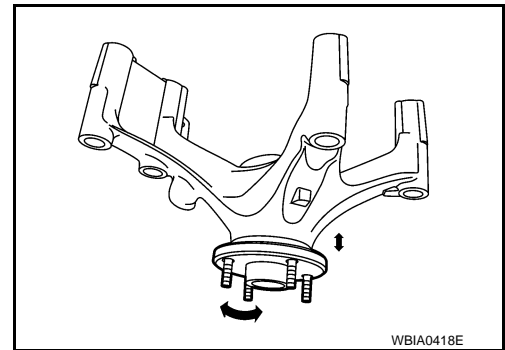

INSPECTION AFTER INSTALLATION

- Check for leaks of the engine coolant. Refer to [CO-8, "Inspection"](#).
- Start and warm up the engine. Visually make sure that there are no leaks of the engine coolant.

WATER PUMP

< REMOVAL AND INSTALLATION >

WATER PUMP

Exploded View

INFOID:000000009010945

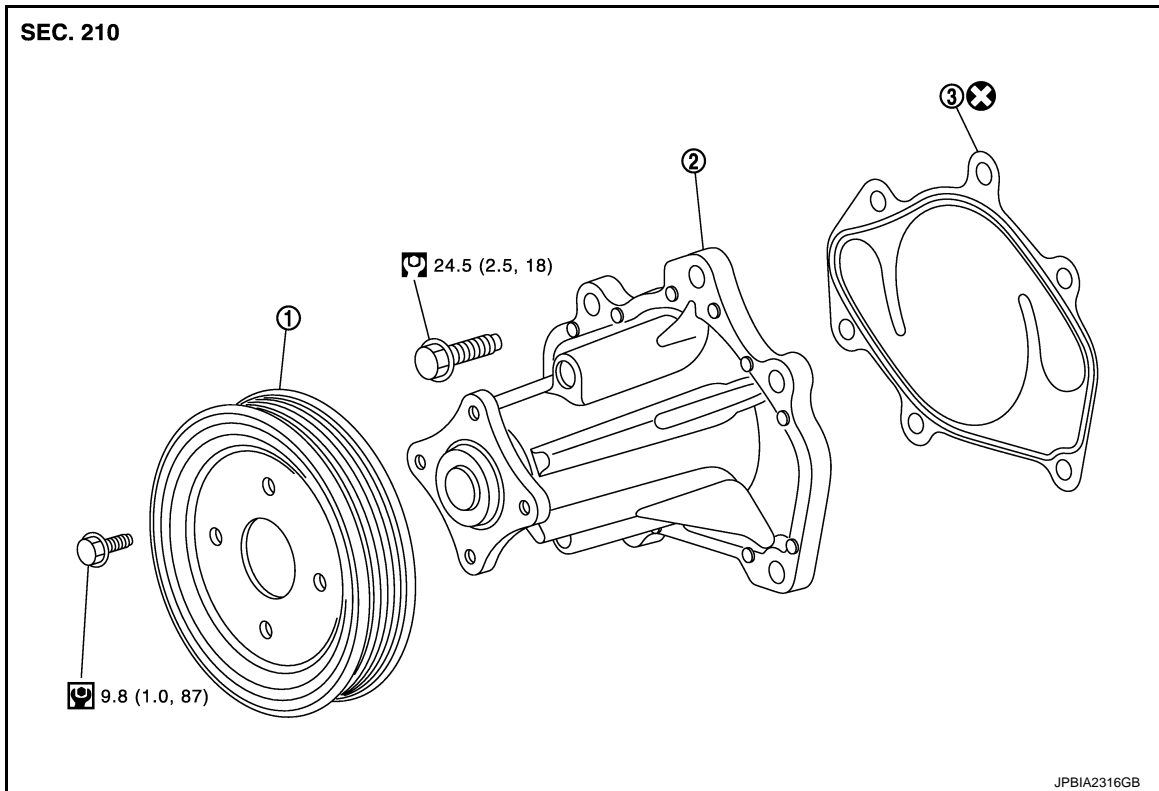

1. Water pump pulley

2. Water pump

3. Gasket

Refer to [GI-4, "Components"](#) for symbols in the figure.

Removal and Installation

INFOID:000000009010946

CAUTION:

- When removing water pump assembly, be careful not to get engine coolant on drive belts.
- Water pump cannot be disassembled and should be replaced as a unit.
- After installing water pump, connect hose and clamp securely, then check for leakage using the radiator cap tester (commercial service tool) and the radiator cap tester adapter (commercial service tool).

REMOVAL

1. Drain engine coolant from drain plugs on radiator and cylinder block. Refer to [CO-8, "Draining"](#) and [EM-109, "Setting"](#).
- CAUTION:**
- Perform this step when engine is cold.
 - Never spill engine coolant on drive belt.
2. Remove front under cover with power tool. Refer to [EXT-26, "Exploded View"](#).
 3. Remove fan shroud (lower). Refer to [CO-14, "Exploded View"](#).
 4. Move reservoir tank to the position with out the hindrance for work. Refer to [CO-14, "Exploded View"](#).
 5. Remove radiator core support cover. Refer to [DLK-226, "Exploded View"](#).
 6. Remove fan shroud (upper). Refer to [CO-14, "Exploded View"](#).
 7. Remove drive belt. Refer to [EM-20, "Exploded View"](#).
 8. Remove cooling fan, fan coupling, cooling fan pulley and bracket. Refer to [CO-18, "Exploded View"](#).
 9. Remove radiator hose (upper). Refer to [CO-14, "Exploded View"](#).
 10. Remove water pump pulley.

WATER PUMP

< REMOVAL AND INSTALLATION >

11. Remove water pump. Refer to [CO-20, "Exploded View"](#).
 - Engine coolant will leak from cylinder block, so have a receptacle ready under vehicle.
- CAUTION:**
- **Handle the water pump vane so that it does not contact any other parts.**
 - **Never disassemble water pump.**

INSTALLATION

Install in the reverse order of removal.

Inspection

INFOID:000000009010947

INSPECTION AFTER REMOVAL

- Visually check that there is no significant dirt or rusting on water pump body and vane (A).
- Check there is no slack in vane shaft, and that it turns smoothly when rotated by hand.
- If anything is found, replace water pump.

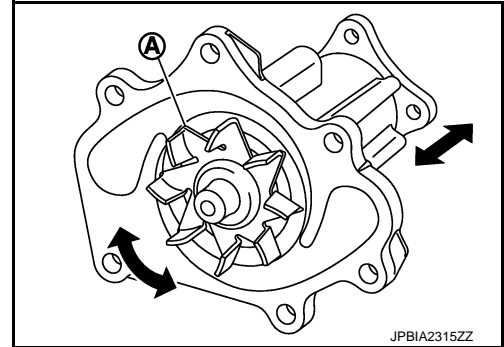

INSPECTION AFTER INSTALLATION

- Check that the reservoir tank cap is tightened.
- Check for leakage of engine coolant using the radiator cap tester adapter (commercial service tool) and the radiator cap tester (commercial service tool). Refer to [CO-8, "Inspection"](#).
- Start and warm up the engine. Visually check that there is no leakage of engine coolant.

WATER INLET AND THERMOSTAT ASSEMBLY

< REMOVAL AND INSTALLATION >

WATER INLET AND THERMOSTAT ASSEMBLY

Exploded View

INFOID:000000009010948

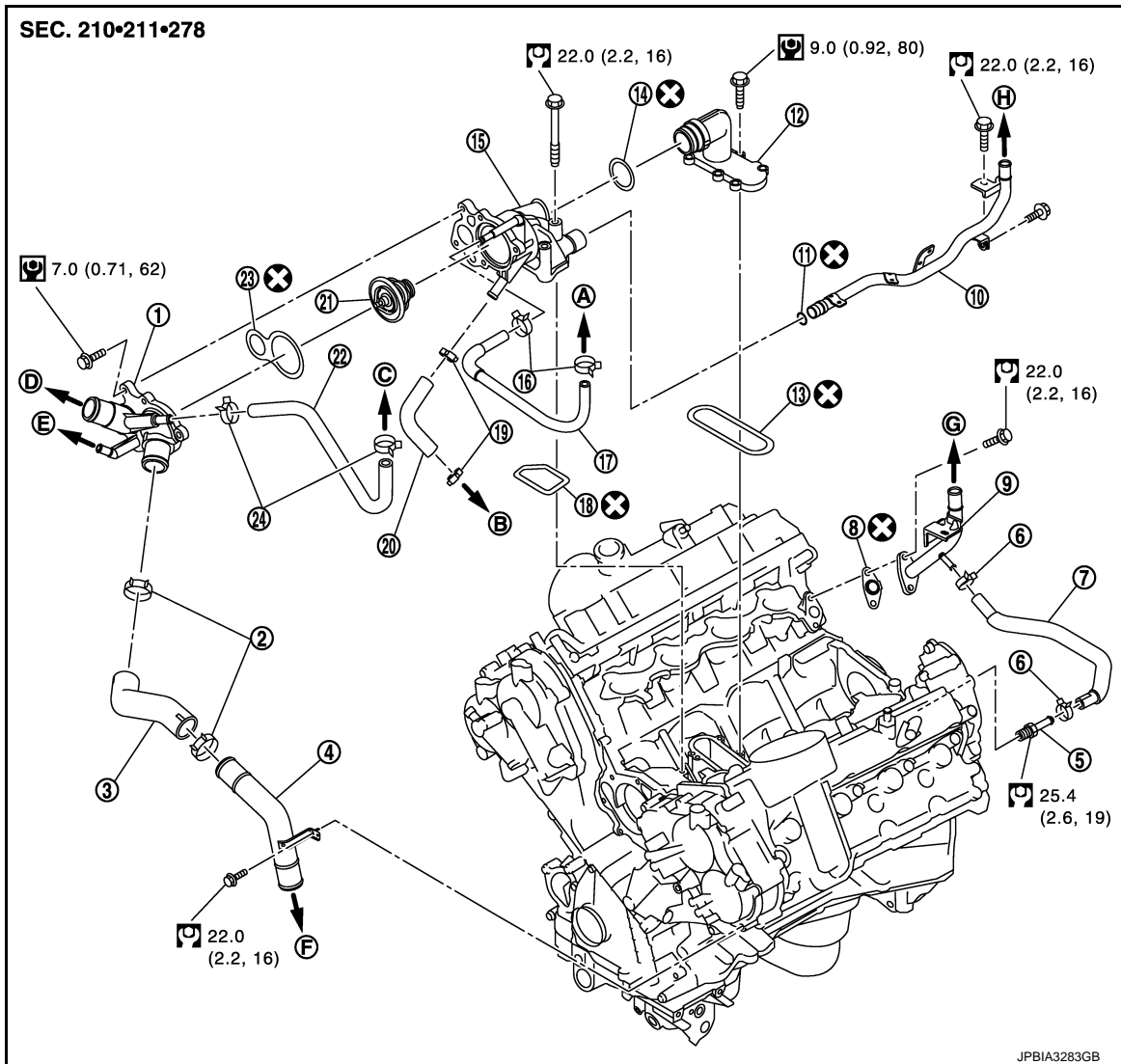

- | | | |
|--|----------------------|--|
| 1. Water inlet | 2. Clamp | 3. Water suction hose |
| 4. Water suction pipe | 5. Hose connector | 6. Clamp |
| 7. Water hose | 8. Gasket | 9. Water pipe |
| 10. Heater pipe | 11. O-ring | 12. Water connector |
| 13. Pakkin | 14. O-ring | 15. Thermostat housing |
| 16. Clamp | 17. Water hose | 18. Pakkin |
| 19. Clamp | 20. Water hose | 21. Thermostat |
| 22. Water hose | 23. Pakkin | 24. Clamp |
| A. To electric throttle control actuator | B. To oil cooler | C. To electric throttle control actuator |
| D. To radiator | E. To reservoir tank | F. To radiator |
| G. To heater | H. To heater | |

Refer to [GI-4, "Components"](#) for symbols in the figure.

Removal and Installation

INFOID:000000009010949

REMOVAL

1. Remove engine cover. Refer to [EM-26, "Exploded View"](#).

WATER INLET AND THERMOSTAT ASSEMBLY

< REMOVAL AND INSTALLATION >

- Remove front under cover with power tool. Refer to [EXT-26, "Exploded View"](#).
 - Drain engine coolant from drain plugs on radiator and cylinder block. Refer to [CO-8, "Draining"](#) and [EM-109, "Setting"](#).
- CAUTION:**
- Perform this step when engine is cold.
 - Never spill engine coolant on drive belts.
- Disconnect radiator hose (upper and lower). Refer to [CO-14, "Exploded View"](#).
 - Remove intake manifold. Refer to [EM-31, "Exploded View"](#).
 - Remove fuel feed tube. Refer to [EM-44, "Exploded View"](#).
 - Remove water hose, water connector, heater pipes and heater hoses.
 - Remove thermostat housing.
 - Remove water inlet and thermostat.

INSTALLATION

Note the following, and install in the reverse order of removal.

CAUTION:

- Do not reuse O-rings.
- Be careful not to spill engine coolant over engine room. Use rag to absorb engine coolant.

Thermostat

- Install thermostat with the whole circumference of each flange part (A) fit securely inside rubber ring (1).

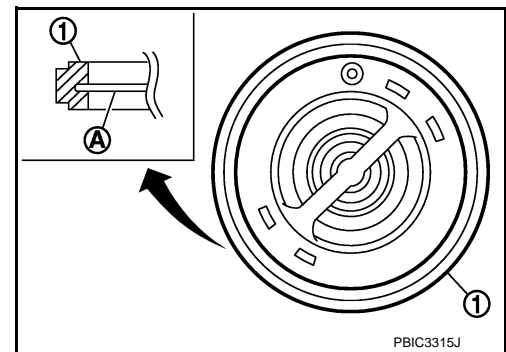

- Install thermostat with jiggle valve (A) facing upwards. The position deviation may be within the range of 20 degrees (b).

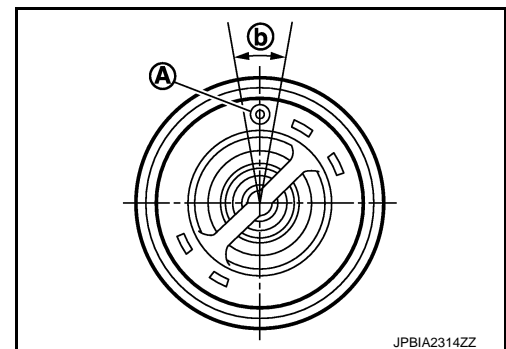

Water Connector and Heater Pipe

CAUTION:

Do not reuse O-rings.

- First apply a neutral detergent to O-rings, then quickly insert the insertion parts of the water connector and heater pipe into the installation holes.

Inspection

INFOID:000000009010950

INSPECTION AFTER REMOVAL

- Check that valve in thermostat is completely closing at normal temperature.

WATER INLET AND THERMOSTAT ASSEMBLY

< REMOVAL AND INSTALLATION >

- Place a thread (A) so that it is caught in the valve of the thermostat. Immerse fully in a container filled with water. Heat while stirring.
- The valve opening temperature is the temperature at which the valve opens and falls from the thread.
- After checking the maximum valve lift, lower the water temperature and check the valve closing temperature.

Thermostat (Standard) : Refer to [CO-25, "Thermostat"](#).

- If the malfunctioning condition, when valve seating at ordinary room temperature, or measured values are out of the standard, replace thermostat.

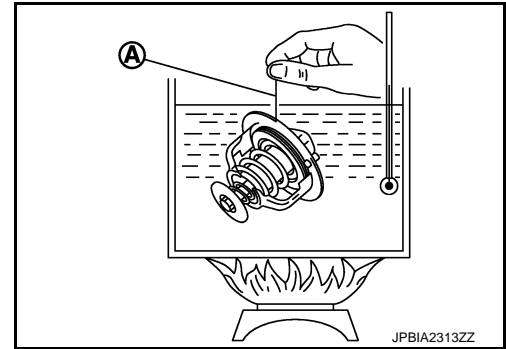

INSPECTION AFTER INSTALLATION

- Check that the reservoir tank cap is tightened.
- Check for leakage of engine coolant using the radiator cap tester adapter (commercial service tool) and the radiator cap tester (commercial service tool). Refer to [CO-8, "Inspection"](#).
- Start and warm up the engine. Visually check that there is no leakage of engine coolant.

SERVICE DATA AND SPECIFICATIONS (SDS)

< SERVICE DATA AND SPECIFICATIONS (SDS)

SERVICE DATA AND SPECIFICATIONS (SDS)

SERVICE DATA AND SPECIFICATIONS (SDS)

Periodical Maintenance Specification

INFOID:000000009010951

A

CO

ENGINE COOLANT CAPACITY (APPROXIMATELY)

Unit: ℓ (US qt, Imp qt)

Engine coolant capacity [With reservoir tank ("MAX" level)]	14.9 (15-6/8, 13-1/8)
Reservoir tank engine coolant capacity (At "MAX" level)	1.0 (1, 7/8)

C

D

Radiator

INFOID:000000009010952

Unit: kPa (kg/cm², psi)

Reservoir tank cap relief pressure	Standard	108.2 - 127.8 (1.1 - 1.3, 15.7 - 18.5)
	Limit	98 (1.0, 14)
Leakage testing pressure		186 (1.9, 27)

E

F

Thermostat

INFOID:000000009010953

Thermostat	Standard
Valve opening temperature	82°C (180°F)
Maximum valve lift	10.0 mm/95°C (0.394 in/203°F)
Valve closing temperature	77°C (171°F)

G

H

I

J

K

L

M

N

O

P