

# SECTION **EXL**

## EXTERIOR LIGHTING SYSTEM

A  
B  
C  
D  
E  
F  
G  
H  
I  
J  
K  
L  
M  
N  
O  
P

### CONTENTS

<p style="text-align: center;"><b>XENON TYPE</b></p> <p><b>PRECAUTION</b> ..... 5</p> <p><b>PRECAUTIONS</b> ..... 5</p> <p style="padding-left: 20px;">Precaution for Supplemental Restraint System (SRS) "AIR BAG" and "SEAT BELT PRE-TENSIONER" .....5</p> <p style="padding-left: 20px;">Precautions for Removing of Battery Terminal .....5</p> <p><b>SYSTEM DESCRIPTION</b> ..... 6</p> <p><b>COMPONENT PARTS</b> ..... 6</p> <p><b>EXTERIOR LIGHTING SYSTEM</b> .....6</p> <p style="padding-left: 20px;">EXTERIOR LIGHTING SYSTEM : Component Parts Location .....6</p> <p style="padding-left: 20px;">EXTERIOR LIGHTING SYSTEM : Component Description .....7</p> <p><b>FRONT COMBINATION LAMP</b> .....8</p> <p style="padding-left: 20px;">FRONT COMBINATION LAMP : Xenon Headlamp .....8</p> <p style="padding-left: 20px;">FRONT COMBINATION LAMP : HID Control Unit.....9</p> <p style="padding-left: 20px;">FRONT COMBINATION LAMP : High Beam Solenoid .....9</p> <p style="padding-left: 20px;">FRONT COMBINATION LAMP : Headlamp Aiming Motor .....9</p> <p style="padding-left: 20px;">FRONT COMBINATION LAMP : Swivel Actuator.....9</p> <p><b>SYSTEM</b> .....10</p> <p><b>HEADLAMP SYSTEM</b> .....10</p> <p style="padding-left: 20px;">HEADLAMP SYSTEM : System Diagram ..... 10</p> <p style="padding-left: 20px;">HEADLAMP SYSTEM : System Description ..... 10</p> <p style="padding-left: 20px;">HEADLAMP SYSTEM : Fail-safe ..... 10</p> <p><b>AUTO LIGHT SYSTEM</b> ..... 11</p> <p style="padding-left: 20px;">AUTO LIGHT SYSTEM : System Diagram ..... 11</p> <p style="padding-left: 20px;">AUTO LIGHT SYSTEM : System Description (For CANADA) ..... 11</p> <p style="padding-left: 20px;">AUTO LIGHT SYSTEM : System Description (Except for CANADA) ..... 12</p>	<p><b>DAYTIME RUNNING LIGHT SYSTEM</b> .....13</p> <p style="padding-left: 20px;">DAYTIME RUNNING LIGHT SYSTEM : System Diagram .....13</p> <p style="padding-left: 20px;">DAYTIME RUNNING LIGHT SYSTEM : System Description .....13</p> <p><b>ACTIVE ADAPTIVE FRONT-LIGHTING SYSTEM</b>.....14</p> <p style="padding-left: 20px;">ACTIVE ADAPTIVE FRONT-LIGHTING SYSTEM : System Diagram .....14</p> <p style="padding-left: 20px;">ACTIVE ADAPTIVE FRONT-LIGHTING SYSTEM : System Description .....14</p> <p style="padding-left: 20px;">ACTIVE ADAPTIVE FRONT-LIGHTING SYSTEM : Fail-safe .....16</p> <p><b>HEADLAMP AIMING CONTROL (MANUAL)</b> .....17</p> <p style="padding-left: 20px;">HEADLAMP AIMING CONTROL (MANUAL) : System Description .....17</p> <p><b>TURN SIGNAL AND HAZARD WARNING LAMP SYSTEM</b> .....17</p> <p style="padding-left: 20px;">TURN SIGNAL AND HAZARD WARNING LAMP SYSTEM : System Diagram .....17</p> <p style="padding-left: 20px;">TURN SIGNAL AND HAZARD WARNING LAMP SYSTEM : System Description .....17</p> <p><b>PARKING, LICENSE PLATE, SIDE MARKER AND TAIL LAMP SYSTEM</b> .....18</p> <p style="padding-left: 20px;">PARKING, LICENSE PLATE, SIDE MARKER AND TAIL LAMP SYSTEM : System Diagram .....18</p> <p style="padding-left: 20px;">PARKING, LICENSE PLATE, SIDE MARKER AND TAIL LAMP SYSTEM : System Description.....18</p> <p style="padding-left: 20px;">PARKING, LICENSE PLATE, SIDE MARKER AND TAIL LAMP SYSTEM : Fail-safe .....18</p> <p><b>FRONT FOG LAMP SYSTEM</b> .....19</p> <p style="padding-left: 20px;">FRONT FOG LAMP SYSTEM : System Diagram.....19</p> <p style="padding-left: 20px;">FRONT FOG LAMP SYSTEM : System Description .....19</p> <p style="padding-left: 20px;">FRONT FOG LAMP SYSTEM : Fail-safe .....19</p> <p><b>EXTERIOR LAMP BATTERY SAVER SYSTEM</b> .....19</p>
---	--

EXL

EXTERIOR LAMP BATTERY SAVER SYSTEM :	ADDITIONAL SERVICE WHEN REPLACING
System Diagram ..... 20	CONTROL UNIT (HEIGHT SENSOR) : Special
EXTERIOR LAMP BATTERY SAVER SYSTEM :	Repair Requirement ..... 63
System Description ..... 20	
<b>DIAGNOSIS SYSTEM (BCM) ..... 21</b>	<b>LEVELIZER ADJUSTMENT ..... 63</b>
<b>COMMON ITEM ..... 21</b>	LEVELIZER ADJUSTMENT : Description ..... 63
COMMON ITEM : CONSULT Function (BCM -	LEVELIZER ADJUSTMENT : Special Repair Re-
COMMON ITEM) ..... 21	quirement ..... 63
<b>HEADLAMP ..... 22</b>	<b>DTC/CIRCUIT DIAGNOSIS ..... 65</b>
HEADLAMP : CONSULT Function (BCM - HEAD	<b>B2503, B2504 SWIVEL ACTUATOR ..... 65</b>
LAMP) ..... 22	DTC Logic ..... 65
<b>FLASHER ..... 25</b>	Diagnosis Procedure ..... 66
FLASHER : CONSULT Function (BCM - FLASH-	Component Inspection ..... 69
ER) ..... 25	<b>B2513 HEIGHT SENSOR UNUSUAL [FR] ..... 70</b>
<b>DIAGNOSIS SYSTEM (IPDM E/R) ..... 27</b>	DTC Logic ..... 70
Diagnosis Description ..... 27	Diagnosis Procedure ..... 70
CONSULT Function (IPDM E/R) ..... 29	<b>B2514 HEIGHT SENSOR UNUSUAL [RR] ..... 73</b>
<b>DIAGNOSIS SYSTEM (AFS) ..... 32</b>	DTC Logic ..... 73
CONSULT Function (ADAPTIVE LIGHT) ..... 32	Diagnosis Procedure ..... 73
<b>ECU DIAGNOSIS INFORMATION ..... 34</b>	<b>B2516 SHIFT SIGNAL [P, R] ..... 76</b>
<b>BCM, IPDM E/R ..... 34</b>	DTC Logic ..... 76
List of ECU Reference ..... 34	Diagnosis Procedure ..... 76
<b>AFS CONTROL UNIT ..... 35</b>	<b>B2517 VEHICLE SPEED SIGNAL ..... 77</b>
Reference Value ..... 35	DTC Logic ..... 77
Fail-safe ..... 38	Diagnosis Procedure ..... 77
DTC Inspection Priority Chart ..... 39	<b>B2519 LEVELIZER CALIBRATION ..... 78</b>
DTC Index ..... 39	DTC Logic ..... 78
<b>WIRING DIAGRAM ..... 40</b>	Diagnosis Procedure ..... 78
<b>EXTERIOR LIGHTING SYSTEM ..... 40</b>	<b>B2521 ECU CIRCUIT ..... 79</b>
Wiring Diagram ..... 40	DTC Logic ..... 79
<b>BASIC INSPECTION ..... 60</b>	Diagnosis Procedure ..... 79
<b>DIAGNOSIS AND REPAIR WORK FLOW ..... 60</b>	<b>C0126 STEERING ANGLE SENSOR SIGNAL.. 82</b>
Work Flow ..... 60	DTC Logic ..... 82
<b>INSPECTION AND ADJUSTMENT ..... 63</b>	Diagnosis Procedure ..... 82
<b>ADDITIONAL SERVICE WHEN REPLACING</b>	<b>C0428 STEERING ANGLE SENSOR CALI-</b>
<b>CONTROL UNIT (AFS CONTROL UNIT) ..... 63</b>	<b>BRATION ..... 83</b>
ADDITIONAL SERVICE WHEN REPLACING	DTC Logic ..... 83
CONTROL UNIT (AFS CONTROL UNIT) : De-	Diagnosis Procedure ..... 83
scription ..... 63	<b>U1000 CAN COMM CIRCUIT ..... 84</b>
ADDITIONAL SERVICE WHEN REPLACING	Description ..... 84
CONTROL UNIT (AFS CONTROL UNIT) : Special	DTC Logic ..... 84
Repair Requirement ..... 63	Diagnosis Procedure ..... 84
<b>ADDITIONAL SERVICE WHEN REPLACING</b>	<b>U1010 CONTROL UNIT (CAN) ..... 85</b>
<b>CONTROL UNIT (HEIGHT SENSOR) ..... 63</b>	DTC Logic ..... 85
ADDITIONAL SERVICE WHEN REPLACING	Diagnosis Procedure ..... 85
CONTROL UNIT (HEIGHT SENSOR) : Descrip-	<b>POWER SUPPLY AND GROUND CIRCUIT .... 86</b>
tion ..... 63	<b>AFS CONTROL UNIT ..... 86</b>
	AFS CONTROL UNIT : Diagnosis Procedure ..... 86

<b>HEADLAMP (HI) CIRCUIT</b> .....	<b>87</b>	<b>BOTH SIDE HEADLAMPS DO NOT SWITCH TO HIGH BEAM</b> .....	<b>116</b>	<b>A</b>
Component Function Check .....	87	Description .....	116	
Diagnosis Procedure .....	87	Diagnosis Procedure .....	116	
<b>HEADLAMP (LO) CIRCUIT</b> .....	<b>89</b>	<b>BOTH SIDE HEADLAMPS (LO) ARE NOT TURNED ON</b> .....	<b>117</b>	<b>B</b>
Component Function Check .....	89	Description .....	117	
Diagnosis Procedure .....	89	Diagnosis Procedure .....	117	<b>C</b>
<b>XENON HEADLAMP</b> .....	<b>91</b>	<b>PARKING, LICENSE PLATE, SIDE MARKER AND TAIL LAMPS ARE NOT TURNED ON ...</b> .....	<b>118</b>	<b>D</b>
Diagnosis Procedure .....	91	Description .....	118	
<b>HEADLAMP LEVELIZER CIRCUIT</b> .....	<b>92</b>	Diagnosis Procedure .....	118	
Component Function Check .....	92	<b>BOTH SIDE FRONT FOG LAMPS ARE NOT TURNED ON</b> .....	<b>119</b>	<b>E</b>
Diagnosis Procedure .....	92	Description .....	119	
<b>HEADLAMP AIMING SYSTEM (MANUAL)</b> .....	<b>94</b>	Diagnosis Procedure .....	119	<b>F</b>
Component Inspection .....	94	<b>PERIODIC MAINTENANCE</b> .....	<b>120</b>	
<b>FRONT FOG LAMP CIRCUIT</b> .....	<b>95</b>	<b>HEADLAMP AIMING ADJUSTMENT</b> .....	<b>120</b>	<b>G</b>
Component Function Check .....	95	description .....	120	
Diagnosis Procedure .....	95	Aiming Adjustment Procedure .....	121	<b>H</b>
<b>PARKING LAMP CIRCUIT</b> .....	<b>97</b>	<b>FRONT FOG LAMP AIMING ADJUSTMENT</b> .....	<b>122</b>	<b>I</b>
Component Function Check .....	97	Description .....	122	
Diagnosis Procedure .....	97	Aiming Adjustment Procedure .....	122	<b>J</b>
<b>FRONT SIDE MARKER LAMP CIRCUIT</b> .....	<b>99</b>	<b>REMOVAL AND INSTALLATION</b> .....	<b>124</b>	<b>K</b>
Component Function Check .....	99	<b>FRONT COMBINATION LAMP</b> .....	<b>124</b>	
Diagnosis Procedure .....	99	Exploded View .....	124	
<b>TURN SIGNAL LAMP CIRCUIT</b> .....	<b>100</b>	Removal and Installation .....	124	
Component Function Check .....	100	Replacement .....	125	
Diagnosis Procedure .....	100	Disassembly and Assembly .....	126	
<b>OPTICAL SENSOR</b> .....	<b>103</b>	<b>FRONT FOG LAMP</b> .....	<b>127</b>	<b>EXL</b>
Component Function Check .....	103	Exploded View .....	127	
Diagnosis Procedure .....	103	Removal and Installation .....	127	
<b>HAZARD SWITCH</b> .....	<b>106</b>	Replacement .....	127	
Component Function Check .....	106	<b>SIDE TURN SIGNAL LAMP</b> .....	<b>129</b>	<b>M</b>
Diagnosis Procedure .....	106	Exploded View .....	129	
<b>TAIL LAMP CIRCUIT</b> .....	<b>108</b>	Removal and Installation .....	129	
<b>BODY SIDE</b> .....	<b>108</b>	<b>OPTICAL SENSOR</b> .....	<b>130</b>	<b>N</b>
BODY SIDE : Component Function Check .....	108	Exploded View .....	130	
BODY SIDE : Diagnosis Procedure .....	108	Removal and Installation .....	130	
<b>BACK DOOR SIDE</b> .....	<b>109</b>	<b>LIGHTING &amp; TURN SIGNAL SWITCH</b> .....	<b>131</b>	<b>O</b>
BACK DOOR SIDE : Component Function Check .....	109	Exploded View .....	131	
BACK DOOR SIDE : Diagnosis Procedure .....	110	<b>HAZARD SWITCH</b> .....	<b>132</b>	<b>P</b>
<b>LICENSE PLATE LAMP CIRCUIT</b> .....	<b>111</b>	Exploded View .....	132	
Component Function Check .....	111	<b>AFS CONTROL UNIT</b> .....	<b>133</b>	
Diagnosis Procedure .....	111	Exploded View .....	133	
<b>SYMPTOM DIAGNOSIS</b> .....	<b>112</b>	Removal and Installation .....	133	
<b>EXTERIOR LIGHTING SYSTEM SYMPTOMS.</b> .....	<b>112</b>	<b>HEIGHT SENSOR</b> .....	<b>134</b>	
Symptom Table .....	112			
<b>NORMAL OPERATING CONDITION</b> .....	<b>115</b>			
Description .....	115			

---

Exploded View .....	134	Replacement .....	140
Removal and Installation .....	134		
<b>REAR COMBINATION LAMP .....</b>	<b>136</b>	<b>LICENSE PLATE LAMP .....</b>	<b>141</b>
Exploded View .....	136	Exploded View .....	141
Removal and Installation .....	136	Removal and Installation .....	141
		Replacement .....	141
<b>HIGH-MOUNTED STOP LAMP .....</b>	<b>138</b>	<b>SERVICE DATA AND SPECIFICATIONS</b>	
Exploded View .....	138	<b>(SDS) .....</b>	<b>143</b>
Removal and Installation .....	138		
<b>BACK-UP LAMP .....</b>	<b>139</b>	<b>SERVICE DATA AND SPECIFICATIONS</b>	
Exploded View .....	139	<b>(SDS) .....</b>	<b>143</b>
Removal and Installation .....	139	Bulb Specifications .....	143

PRECAUTION

PRECAUTIONS

Precaution for Supplemental Restraint System (SRS) "AIR BAG" and "SEAT BELT PRE-TENSIONER"

INFOID:000000009010209

The Supplemental Restraint System such as "AIR BAG" and "SEAT BELT PRE-TENSIONER", used along with a front seat belt, helps to reduce the risk or severity of injury to the driver and front passenger for certain types of collision. Information necessary to service the system safely is included in the "SRS AIR BAG" and "SEAT BELT" of this Service Manual.

**WARNING:**

Always observe the following items for preventing accidental activation.

- To avoid rendering the SRS inoperative, which could increase the risk of personal injury or death in the event of a collision that would result in air bag inflation, all maintenance must be performed by an authorized NISSAN/INFINITI dealer.
- Improper maintenance, including incorrect removal and installation of the SRS, can lead to personal injury caused by unintentional activation of the system. For removal of Spiral Cable and Air Bag Module, see "SRS AIR BAG".
- Never use electrical test equipment on any circuit related to the SRS unless instructed to in this Service Manual. SRS wiring harnesses can be identified by yellow and/or orange harnesses or harness connectors.

PRECAUTIONS WHEN USING POWER TOOLS (AIR OR ELECTRIC) AND HAMMERS

**WARNING:**

Always observe the following items for preventing accidental activation.

- When working near the Air Bag Diagnosis Sensor Unit or other Air Bag System sensors with the ignition ON or engine running, never use air or electric power tools or strike near the sensor(s) with a hammer. Heavy vibration could activate the sensor(s) and deploy the air bag(s), possibly causing serious injury.
- When using air or electric power tools or hammers, always switch the ignition OFF, disconnect the battery, and wait at least 3 minutes before performing any service.

Precautions for Removing of Battery Terminal

INFOID:00000000988621

- When removing the 12V battery terminal, turn OFF the ignition switch and wait at least 30 seconds.

**NOTE:**

ECU may be active for several tens of seconds after the ignition switch is turned OFF. If the battery terminal is removed before ECU stops, then a DTC detection error or ECU data corruption may occur.

- For vehicles with the 2-batteries, be sure to connect the main battery and the sub battery before turning ON the ignition switch.

**NOTE:**

If the ignition switch is turned ON with any one of the terminals of main battery and sub battery disconnected, then DTC may be detected.

- After installing the 12V battery, always check "Self Diagnosis Result" of all ECUs and erase DTC.

**NOTE:**

The removal of 12V battery may cause a DTC detection error.

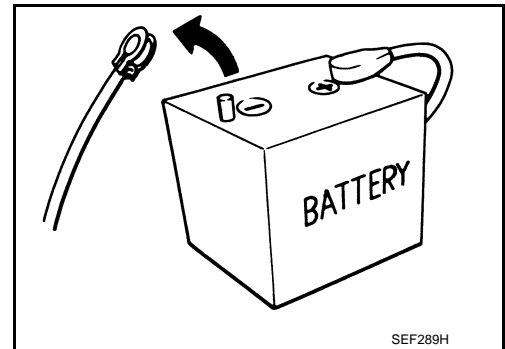

A  
B  
C  
D  
E  
F  
G  
H  
I  
J  
K  
EXL  
M  
N  
O  
P

# SYSTEM DESCRIPTION

## COMPONENT PARTS

### EXTERIOR LIGHTING SYSTEM

#### EXTERIOR LIGHTING SYSTEM : Component Parts Location

INFOID:000000009010210

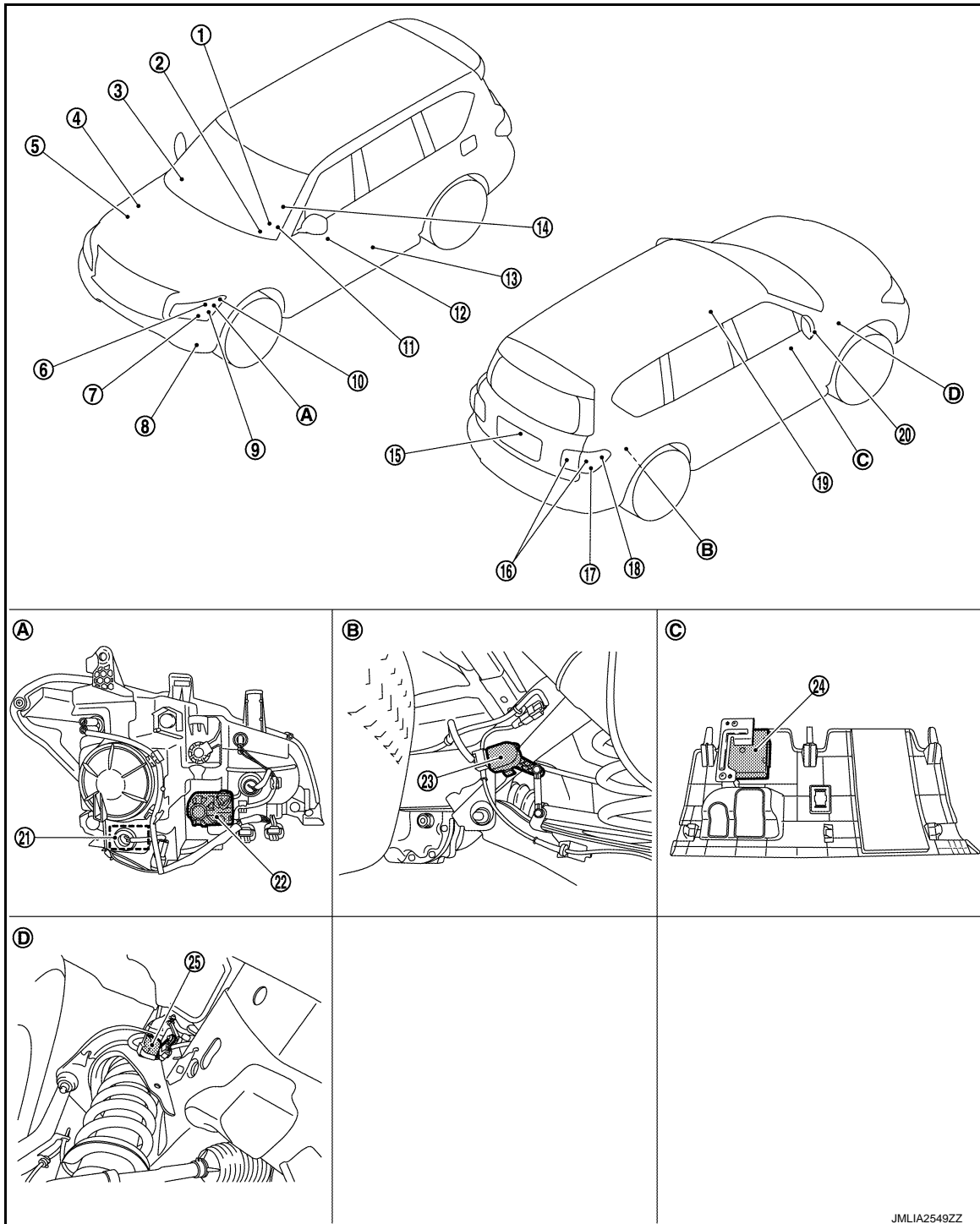

# COMPONENT PARTS

[XENON TYPE]

< SYSTEM DESCRIPTION >

- |   |  |                                     |   |
|---|--|-------------------------------------|---|
| 1. Combination meter  | 2. BCM<br>Refer to <a href="#">BCS-4, "BODY CONTROL SYSTEM : Component Parts Location"</a> | 3. Optical sensor                   | A |
| 4. IPDM E/R<br>Refer to <a href="#">PCS-4, "Component Parts Location"</a> | 5. ECM<br>Refer to <a href="#">EC-23, "Component Parts Location"</a>                       | 6. Parking lamp                     | B |
| 7. Front turn signal lamp   | 8. Front fog lamp  | 9. Headlamp                         | C |
| 10. Front side marker lamp  | 11. Combination switch   | 12. Headlamp aiming switch*1        |   |
| 13. Front door switch (driver side)                                       | 14. Steering angle sensor*2<br>Refer to <a href="#">BRC-9, "Component Parts Location"</a>  | 15. License plate lamp              | D |
| 16. Tail lamp   | 17. Rear turn signal lamp  | 18. Rear side marker lamp           |   |
| 19. Hazard switch   | 20. Side turn signal lamp  | 21. Headlamp swivel actuator        | E |
| 22. Headlamp aiming motor   | 23. Rear height sensor*2   | 24. AFS control unit*2              |   |
| 25. Front height sensor*2   |  |                                     |   |
| A. Front combination lamp (back)  | B. Rear suspension member (RH)   | C. View with instrument lower cover | F |
| D. Front suspension arm (RH)  |  |                                     |   |

\*1: With headlamp aiming control system (manual) models

\*2: With AFS system models

## EXTERIOR LIGHTING SYSTEM : Component Description

INFOID:000000009010211

Part	Description	
BCM	Controls the exterior lighting system.	
ECM*1	Transmits engine speed signal to AFS control unit. (via CAN communication)	
TCM*1	Transmits Shift position signal to AFS control unit. (via CAN communication)	
IPDM E/R	Controls the integrated relay, and supplies voltage to the load according to the request from BCM (via CAN communication).	
AFS control unit*1	AFS control unit judges the vehicle condition from each signal. AFS control unit controls AFS function and the headlamp aiming.	
Combination meter	<ul style="list-style-type: none"> <li>Outputs the vehicle speed signal (8-pulse) to AFS control unit.</li> <li>Blinks the turn signal indicator lamp and outputs the turn signal operating sound with integrated buzzer according to the request from BCM (via CAN communication).</li> <li>Turns the position lamp indicator lamp and high beam indicator lamp ON according to the request from BCM (via CAN communication).</li> <li>Turns the AFS OFF indicator lamp ON/OFF/blinking according to the request from AFS control unit (via CAN communication).</li> </ul>	
Headlamp assembly	Xenon bulb	Refer to <a href="#">EXL-8, "FRONT COMBINATION LAMP : Xenon Headlamp"</a> .
	HID control unit	Refer to <a href="#">EXL-9, "FRONT COMBINATION LAMP : HID Control Unit"</a> .
	High beam solenoid	Refer to <a href="#">EXL-9, "FRONT COMBINATION LAMP : High Beam Solenoid"</a> .
	Headlamp aiming motor	Refer to <a href="#">EXL-9, "FRONT COMBINATION LAMP : Headlamp Aiming Motor"</a> .
	Swivel actuator*1	Refer to <a href="#">EXL-9, "FRONT COMBINATION LAMP : Swivel Actuator"</a> .
Height sensor*1	<ul style="list-style-type: none"> <li>The height sensor is installed to the front suspension member and rear suspension member.</li> <li>The height sensor detects the suspension arm displacement as the vehicle height change.</li> <li>The height sensor transmits the height sensor signal to AFS control unit.</li> </ul> <p><b>NOTE:</b> The sensor angle of the unloaded vehicle position is the reference value.</p>	
Optical sensor	Optical sensor converts the outside brightness (lux) to voltage and transmits the optical sensor signal to BCM.	

# COMPONENT PARTS

< SYSTEM DESCRIPTION >

[XENON TYPE]

Part	Description
Steering angle sensor*1	Transmits steering angle sensor signal to AFS control unit. (via CAN communication)
Combination switch (Lighting & turn signal switch)	Refer to <a href="#">BCS-8, "COMBINATION SWITCH READING SYSTEM : System Description"</a> .
Door switch	Inputs the door switch signal to BCM.
Headlamp aiming switch*2	Outputs the aiming motor drive signal to aiming motor.
Hazard switch	Inputs the hazard switch signal to BCM.

\*1: With AFS system models

\*2: With headlamp aiming control system (manual) models

## FRONT COMBINATION LAMP

### FRONT COMBINATION LAMP : Xenon Headlamp

INFOID:000000009010212

#### OUTLINE

- The lamp light source is by the arch discharge by applying high voltage into the xenon gas-filled bulb instead of the halogen bulb filament.
- Sight becomes more natural and brighter because the amount of light are gained adequately and the color of light is sunshine-like white.
- The xenon bulb drops the amount of light, repeats blinking, and illuminates in red if the bulb reaches the service life.

#### ILLUMINATION PRINCIPLE

1. Discharging starts in high voltage pulse between bulb electrodes.
2. Xenon gas is activated by current between electrodes. Pale light is emitted.
3. The luminous tube (bulb) temperature elevates. Evaporated halide is activated by discharge. The color of light changes into white.

#### NOTE:

- Brightness and the color of light may change slightly immediately after the headlamp turned ON until the xenon bulb becomes stable. This is not malfunction.
- Illumination time lag may occur between right and left. This is not malfunction.

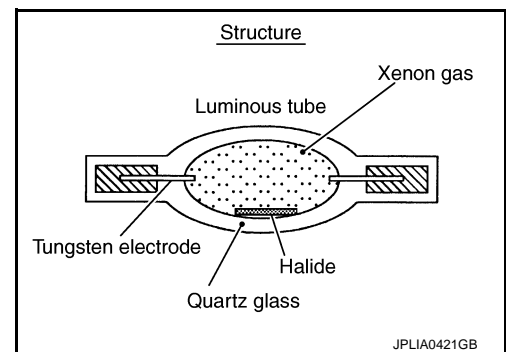

#### PRECAUTIONS FOR TROUBLE DIAGNOSIS

Representative malfunction examples are; "Light does not turn ON", "Light blinks", and "Brightness is inadequate." The cause often be the xenon bulb. Such malfunctions, however, are occurred occasionally by HID control unit malfunction or lamp case malfunction. Specify the malfunctioning part with diagnosis procedure.

#### WARNING:

- **Never touch the harness, HID control unit, the inside and metal part of lamp when turning the headlamp ON or operating the lighting switch.**
- **Never work with wet hands.**

#### CAUTION:

- **Never perform HID control unit circuit diagnosis with a circuit tester or an equivalent.**
- **Temporarily install the headlamps on the vehicle. Connect the battery to the connector (vehicle side) when checking ON/OFF status.**
- **Disconnect the battery negative terminal before disconnecting the lamp socket connector or the harness connector.**
- **Check for fusing of the fusible link(s), open around connector, short, disconnection if the symptom is caused by electric error.**

#### NOTE:

- Turn the switch OFF once before turning ON, if the ON/OFF is inoperative.
- The xenon bulb drops the amount of light, repeats blinking, and illuminates in red if the bulb reaches the service life.



# COMPONENT PARTS

< SYSTEM DESCRIPTION >

[XENON TYPE]

## FRONT COMBINATION LAMP : HID Control Unit

INFOID:0000000009010213

Headlamp (LO) circuit is connected to HID control unit integrated in the headlamp. Headlamp (LO) circuit turns xenon headlamp ON.

For the details of HID control unit and the xenon headlamp, refer to [EXL-8, "FRONT COMBINATION LAMP : Xenon Headlamp"](#).

## FRONT COMBINATION LAMP : High Beam Solenoid

INFOID:0000000009010214

The high beam solenoid drives the mobile valve shade. And the mobile valve shade switches the high beam and low beam of headlamp.

- When the headlamp high relay is turned ON, magnetic force is applied to the high beam solenoid (1) by a current. The mobile valve shade (2) is switched to the high beam position.
- When the headlamp high relay is turned OFF, the current stops. The mobile valve shade returns to the low beam position automatically.

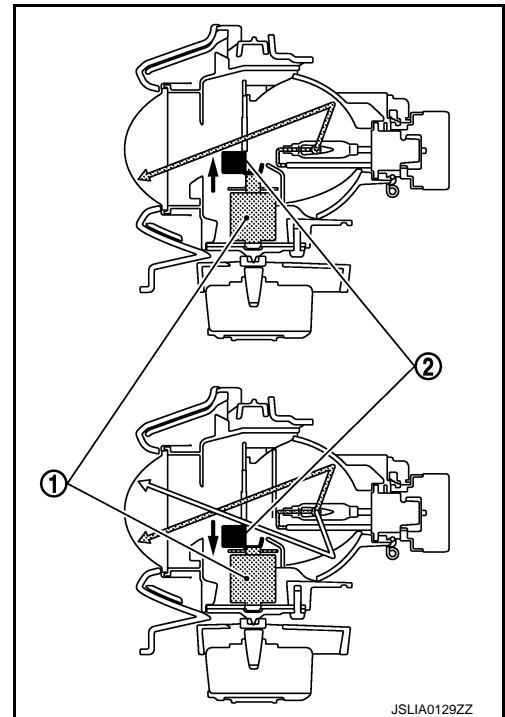

## FRONT COMBINATION LAMP : Headlamp Aiming Motor

INFOID:0000000009010215

The headlamp levelizer adjusts the headlamp light axis upward and downward with the headlamp aiming motor integrated in the front combination lamp.

## FRONT COMBINATION LAMP : Swivel Actuator

INFOID:0000000009010216

### SWIVEL ACTUATOR

The swivel actuator is installed in the headlamp unit. The swivel actuator consists of the swivel motor and the swivel position sensor.

### SWIVEL MOTOR

- The swivel motor is the two-phase step motor.
- The swivel motor drives headlamp by exciting the two drive coils according to the drive signal from AFS control unit.
- The rotation direction of the swivel motor is changeable by changing the exciting pattern.

### SWIVEL POSITION SENSOR

The swivel position sensor detects the headlamp swivel angle to transmit the swivel position sensor signal to AFS control unit.

A  
B  
C  
D  
E  
F  
G  
H  
I  
J  
K  
EXL  
M  
N  
O  
P

SYSTEM

HEADLAMP SYSTEM

HEADLAMP SYSTEM : System Diagram

INFOID:000000009010217

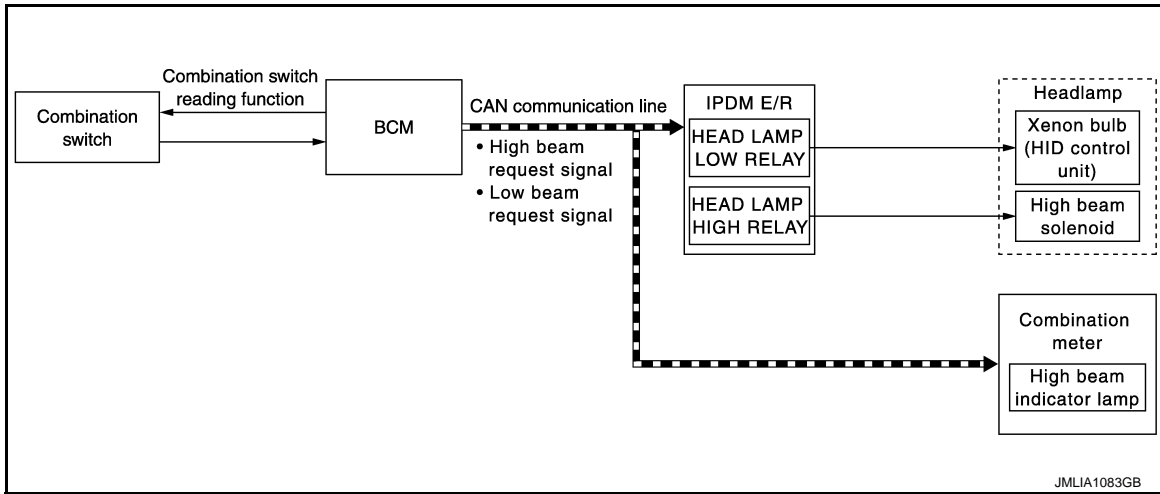

HEADLAMP SYSTEM : System Description

INFOID:000000009010218

OUTLINE

- Mobile valve shade type is adopted. Xenon headlamp switches the high beam and the low beam with one xenon bulb each on right and left.
- Headlamp is controlled by combination switch reading function and headlamp control function of BCM, and relay control function of IPDM E/R.

HEADLAMP BASIC OPERATION

- BCM detects the combination switch condition with the combination switch reading function.
- BCM transmits the low beam request signal to IPDM E/R via CAN communication according to the headlamp ON condition.

Headlamp ON condition

- Lighting switch 2ND
- Lighting switch AUTO (auto light function ON judgment)
- Lighting switch PASS

- IPDM E/R turns the integrated headlamp low relay ON, and turns the headlamp ON according to the low beam request signal.

HEADLAMP HI/LO SWITCHING OPERATION

- BCM transmits the high beam request signal to IPDM E/R and the combination meter via CAN communication according to the high beam switching condition.

High beam switching condition

- Lighting switch HI with the lighting switch 2ND or AUTO (auto light function ON judgment)
- Lighting switch PASS

- Combination meter turns the high beam indicator lamp ON according to the high beam request signal.
- IPDM E/R turns the integrated headlamp high relay ON, and turns the headlamp ON according to the high beam request signal.

HEADLAMP SYSTEM : Fail-safe

INFOID:000000009010219

CAN COMMUNICATION CONTROL

When CAN communication with BCM is impossible, IPDM E/R performs fail-safe control. After CAN communication recovers normally, it also returns to normal control.

If No CAN Communication Is Available With BCM

# SYSTEM

< SYSTEM DESCRIPTION >

[XENON TYPE]

Control part	Fail-safe operation
Headlamp	<ul style="list-style-type: none"> <li>• Turns ON the headlamp low relay when the ignition switch is turned ON</li> <li>• Turns OFF the headlamp low relay when the ignition switch is turned OFF</li> <li>• Headlamp high relay OFF</li> </ul>

## AUTO LIGHT SYSTEM

### AUTO LIGHT SYSTEM : System Diagram

INFOID:000000009010220

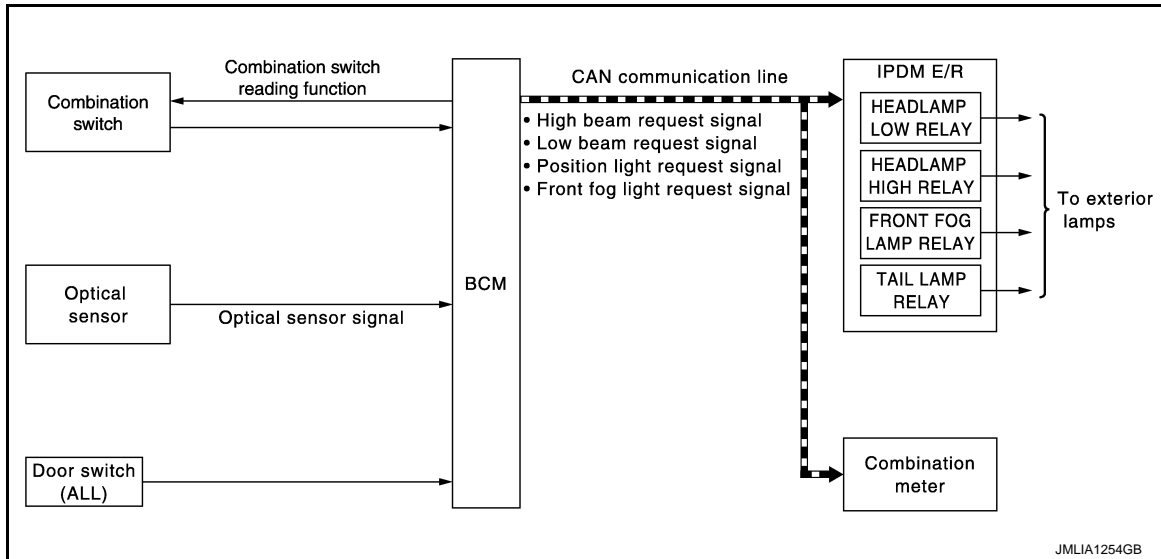

### AUTO LIGHT SYSTEM : System Description (For CANADA)

INFOID:000000009010221

#### OUTLINE

- Auto light system is controlled by each function of BCM and IPDM E/R.

#### Control by BCM

- Combination switch reading function
- Headlamp control function
- Auto light function
- Delay timer function
- Auto light adjustment system

#### Control by IPDM E/R

- Relay control function
- Auto light system has the auto light function, wiper linked auto lighting function and delay timer function.
- Auto light function automatically turns ON/OFF the exterior lamps\* and each illumination automatically, depending on the outside brightness.
- Wiper linked auto lighting function automatically turns ON/OFF the exterior lamps\* and each illumination when the light switch is in the AUTO position, according to a front wiper operation.
- When auto light system turns the exterior lamps ON with the ignition switch OFF, delay timer function turns the exterior lamps OFF, depending on the vehicle condition with the auto light function after a certain period of time.

\*: Headlamp (LO/Hi), parking lamp, side marker lamp, tail lamp and front fog lamp (Headlamp HI and front fog lamp depend on the combination switch condition.)

#### AUTO LIGHT FUNCTION

- BCM detects the combination switch condition with the combination switch reading function.
- BCM supplies voltage to optical sensor when the ignition switch is turned ON or ACC.
- Optical sensor converts outside brightness (lux) to voltage and transmits the optical sensor signal to BCM.
- BCM judges outside brightness from the optical sensor signal and judges ON/OFF condition of the exterior lamp and each illumination according to the outside brightness.
- BCM transmits each request signal to IPDM E/R with CAN communication according to ON/OFF condition by the auto light function.

**NOTE:**

ON/OFF timing differs based on the sensitivity from the setting. The setting can be set by CONSULT. Refer to [EXL-22, "HEADLAMP : CONSULT Function \(BCM - HEAD LAMP\)"](#).

**AUTO LIGHT ADJUSTMENT SYSTEM**

The auto light adjustment system automatically, dims/brightens the display and combination meter, according to brightness outside the vehicle, when lighting switch 1ST or lighting switch 2ND is operated. Refer to [INL-11, "AUTO LIGHT ADJUSTMENT SYSTEM : System Description"](#).

**DELAY TIMER FUNCTION**

BCM turns the exterior lamp OFF depending on the vehicle condition with the auto light function when the ignition switch is turned OFF.

- Turns the exterior lamp OFF 5 minutes after detecting that any door opens. (Door switch ON).
- Turns the exterior lamp OFF a certain period of time\* after closing all doors. (Door switch ON→OFF).
- Turns the exterior lamp OFF with the ignition switch ACC or the light switch OFF.

\*: The preset time is 45 seconds. The timer operating time can be set by CONSULT. Refer to [EXL-22, "HEAD-LAMP : CONSULT Function \(BCM - HEAD LAMP\)"](#).

**NOTE:**

When any position other than the light switch AUTO is set, the auto light system function switches to the exterior lamp battery saver function.

**AUTO LIGHT SYSTEM : System Description (Except for CANADA)**

INFOID:000000009010222

**OUTLINE**

- Auto light system is controlled by each function of BCM and IPDM E/R.

## Control by BCM

- Combination switch reading function
- Headlamp control function
- Auto light function
- Delay timer function
- Wiper linked auto lighting function
- Auto light adjustment system

## Control by IPDM E/R

- Relay control function
- Auto light system has the auto light function (with twilight lighting function), wiper linked auto lighting function and delay timer function.
- Auto light function automatically turns ON/OFF the exterior lamps\* and each illumination automatically, depending on the outside brightness.
- Wiper linked auto lighting function automatically turns ON/OFF the exterior lamps\* and each illumination when the light switch is in the AUTO position, according to a front wiper operation.
- When auto light system turns the exterior lamps ON with the ignition switch OFF, delay timer function turns the exterior lamps OFF, depending on the vehicle condition with the auto light function after a certain period of time.

\*: Headlamp (LO/HI), parking lamp, side marker lamp, tail lamp and front fog lamp (Headlamp HI and front fog lamp depend on the combination switch condition.)

**NOTE:**

The settings of the twilight lighting function and the wiper linked auto lighting function can be changed with CONSULT. Refer to [EXL-22, "HEADLAMP : CONSULT Function \(BCM - HEAD LAMP\)"](#).

**AUTO LIGHT FUNCTION (WITH TWILIGHT LIGHTING FUNCTION)**

## Description

- BCM detects the combination switch condition with the combination switch reading function.
- BCM supplies voltage to the optical sensor when the ignition switch is turned ON or ACC.
- Optical sensor converts outside brightness (lux) to voltage and transmits the optical sensor signal to BCM.
- When ignition switch is turned ON, BCM detects outside brightness from the optical sensor signal and judges ON/OFF condition of the exterior lamp and each illumination, depending on the outside brightness condition (standard or twilight).
- BCM transmits each request signal to IPDM E/R via CAN communication, according to ON/OFF condition by the auto light function.

**NOTE:**

# SYSTEM

< SYSTEM DESCRIPTION >

[XENON TYPE]

As to ON/OFF timing, the sensitivity depends on settings. The settings can be changed with CONSULT. Refer to [EXL-22, "HEADLAMP : CONSULT Function \(BCM - HEAD LAMP\)"](#).

## WIPER LINKED AUTO LIGHTING FUNCTION

BCM turns the exterior lamp ON when detecting 4 operations of the front wiper work the light switch in AUTO position.

### NOTE:

BCM turns OFF the headlamps 3 seconds after the front wiper switch is turned from HI⇒OFF.

## AUTO LIGHT ADJUSTMENT SYSTEM

The auto light adjustment system automatically, dims/brightens the display and combination meter, according to brightness outside the vehicle, when lighting switch 1ST or lighting switch 2ND is operated. Refer to [INL-11, "AUTO LIGHT ADJUSTMENT SYSTEM : System Description"](#).

## DELAY TIMER FUNCTION

BCM turns the exterior lamp OFF depending on the vehicle condition with the auto light function when the ignition switch is turned OFF.

- Turns the exterior lamp OFF 5 minutes after detecting that any door opens. (Door switch ON).
- Turns the exterior lamp OFF a certain period of time\* after closing all doors. (Door switch ON→OFF).
- Turns the exterior lamp OFF with the ignition switch ACC or the light switch OFF.

\*: The preset time is 45 seconds. The timer operating time can be set by CONSULT. Refer to [EXL-22, "HEADLAMP : CONSULT Function \(BCM - HEAD LAMP\)"](#).

### NOTE:

When any position other than the light switch AUTO is set, the auto light system function switches to the exterior lamp battery saver function.

## DAYTIME RUNNING LIGHT SYSTEM

### DAYTIME RUNNING LIGHT SYSTEM : System Diagram

INFOID:000000009010223

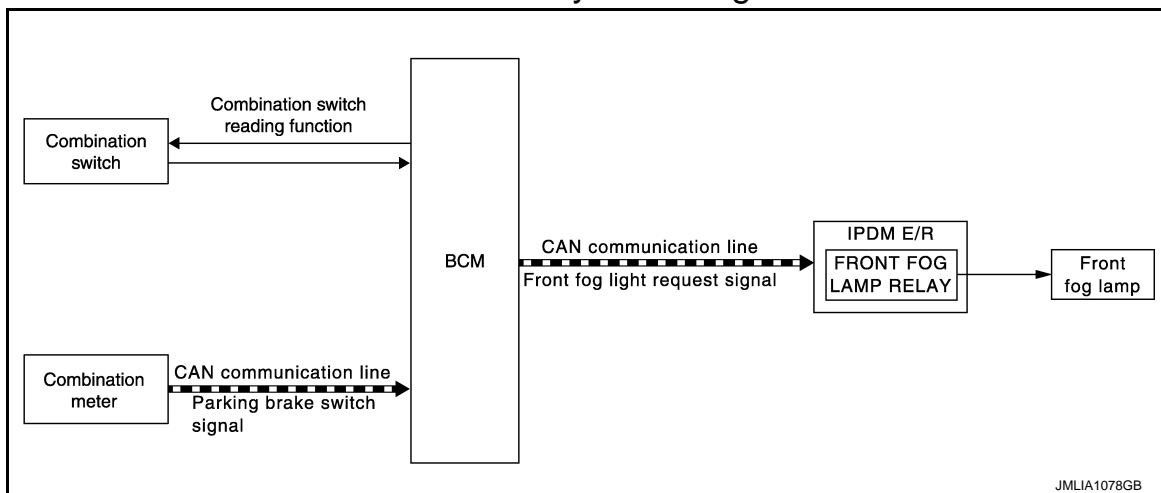

### DAYTIME RUNNING LIGHT SYSTEM : System Description

INFOID:000000009010224

#### OUTLINE

- Turns the front fog lamp ON as the daytime running light.
- Daytime running light is controlled by daytime running light control function and combination switch reading function of BCM, and relay control function of IPDM E/R.

#### DAYTIME RUNNING LIGHT OPERATION

- BCM detects the combination switch condition by the combination switch reading function.
- BCM detects the vehicle condition depending on the following signals.
  - Parking brake switch signal (received from combination meter via CAN communication)
- BCM transmits the front fog light request signal to IPDM E/R via CAN communication according to the daytime running light ON condition.

Daytime running light ON condition

- While the engine running with the parking brake released
- Lighting switch OFF

- Lighting switch AUTO (auto light function OFF judgment)
- Passing switch OFF
- Front fog lamp switch OFF
- IPDM E/R turns the integrated front fog lamp relay ON and turns the front fog lamp ON according to the front fog light request signal.

## ACTIVE ADAPTIVE FRONT-LIGHTING SYSTEM

### ACTIVE ADAPTIVE FRONT-LIGHTING SYSTEM : System Diagram

INFOID:000000009010225

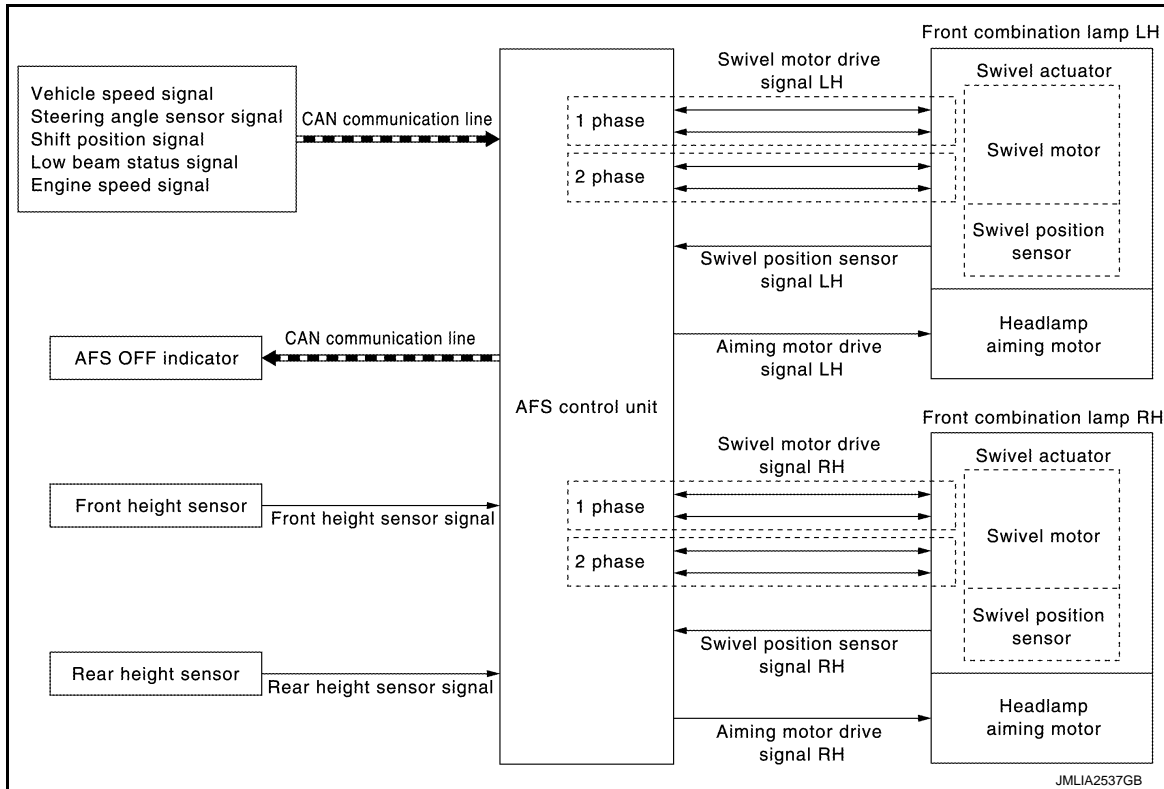

### ACTIVE ADAPTIVE FRONT-LIGHTING SYSTEM : System Description

INFOID:000000009010226

#### OUTLINE

- AFS (ACTIVE ADAPTIVE FRONT-LIGHTING SYSTEM) is controlled by AFS control unit.
- AFS has AFS control (swivel control) and the headlamp auto aiming control.
- AFS control swivels the headlamp to the steering direction.
- Headlamp auto aiming control moves the headlamp light axis up/down according to the vehicle height.

#### AFS (ADAPTIVE FRONT-LIGHTING SYSTEM)

##### AFS Control Description

- AFS control unit controls the headlamp (right) only when the steering wheel is turned rightward, and the headlamp (left) only when the steering wheel is turned leftward.
- AFS control unit detects the vehicle condition necessary for AFS control with the following signals.
- Vehicle speed signal (received from combination meter via CAN communication)
- Steering angle sensor signal (received from steering angle sensor via CAN communication)
- Shift position signal (received from TCM via CAN communication)
- Low beam status signal (received from IPDM E/R via CAN communication)
- Engine speed signal (received from ECM via CAN communication)
- When the operation conditions are satisfied, AFS control unit controls the swivel angle depending on the steering angle and the vehicle speed.

##### AFS operation condition

- Swivel actuator initialization completed
- AFS "ON"(AFS OFF indicator lamp "OFF")
- Headlamp ON

# SYSTEM

[XENON TYPE]

## < SYSTEM DESCRIPTION >

- While the engine running
- Selector lever position other than "P" or "R"
- Vehicle speed approximately 25 km/h (15.5 MPH) or more  
(Left swivel only; Right swivel activates regardless of the vehicle speed.)

### Swivel Actuator Initialization

- AFS control unit performs the swivel actuator initialization when detecting that the engine starts.
- Swivels the headlamp to the vehicle-center side until it hits the stopper.
- Returns the swivel angle from the stopper. Completes the initialization with regarding the returned position as the swivel angle 0° (straight-forward position).

### Swivel Operation

- AFS control unit transmits the drive signal to the swivel actuator when activation conditions are satisfied. And swivels the headlamp.
- The swivel starts after steering approximately 20° or more from straight-forward position.

#### NOTE:

- The steering angle differs between right turn and left turn.
- The swivel angle becomes the maximum angle toward the driving direction if the steering angle is approximately 90° or more depending on the vehicle speed. The swivel angle is maintained by shutting off the drive signal.
- The swivel starts, and returns to the swivel angle 0° (straight-forward position) when the steering is returned to the straight-forward position.
- AFS control unit returns the swivel angle to the straight-forward position, and stops the swivel regardless of the steering angle if the operation condition is not satisfied while the swivel angle is 0°.

### AFS OFF Indicator Lamp

- AFS control unit transmits AFS OFF indicator lamp signal to the combination meter via CAN communication.
- Combination meter turns AFS OFF indicator lamp ON/OFF/blinking according to AFS OFF indicator lamp signal.
- AFS OFF indicator lamp is turned ON for 1 second for the AFS OFF indicator lamp bulb check when the ignition switch is turned ON. AFS OFF indicator lamp is turned OFF within 1 second when the engine starts.
- AFS OFF indicator lamp blinks (1 second each) if AFS control unit detects a specific DTC.

#### NOTE:

Combination meter blinks AFS OFF indicator lamp (approximately 1 second each) if AFS OFF indicator lamp signal is not received from AFS control unit.

## HEADLAMP AUTO AIMING

### Headlamp Auto Aiming Control Description

- AFS control unit controls the headlamp light axis height appropriately according to the vehicle height.
- AFS control unit detects the vehicle condition necessary for headlamp auto aiming control with the following signals.
- Height sensor signals (front and rear)
- Vehicle speed signal (received from combination meter via CAN communication)
- Low beam status signal (received from IPDM E/R via CAN communication)
- Engine speed signal (received from ECM via CAN communication)
- When the operation conditions are satisfied, AFS control unit transmits the aiming motor drive signal for adjusting the headlamp axis height.

### Headlamp auto aiming operation condition

- Headlamp ON
- While the engine running
- Vehicle speed (Control mode is switched according to the driving condition.)

### Headlamp Auto Aiming Operation

- AFS control unit calculates the vehicle pitch angle from the front and rear height sensor signal. AFS control unit judges the angle for adjusting the axis gap from the preset position.
- AFS control unit controls the headlamp axis by changing the aiming motor drive signal output according to the front and rear vehicle height when detecting the following vehicle condition. Output is maintained if other condition than following is detected.
- Engine starts.
- Headlamp is turned ON.
- Vehicle posture becomes stable after changing the vehicle posture change is detected with the headlamp ON and the vehicle stopped.

A

B

C

D

E

F

G

H

I

J

K

EXL

M

N

O

P

# SYSTEM

< SYSTEM DESCRIPTION >

[XENON TYPE]

- Vehicle speed is maintained with the headlamp ON and the vehicle driven.

**NOTE:**

Adjusted axis position may differ from the preset position although the headlamp auto aiming activates properly if the suspension is replaced or worn.

## ACTIVE ADAPTIVE FRONT-LIGHTING SYSTEM : Fail-safe

INFOID:000000009355170

DTC	Fail-safe	AFS OFF indicator lamp	Cancellation
U1000: CAN COMM CIRCUIT	<ul style="list-style-type: none"> <li>Right and left swivel motors stop at the position when DTC is detected.</li> <li>Right and left headlamp aiming motors stop at the position when DTC is detected.</li> </ul>	Blinks 1 second each.	Erasure DTC or Ignition switch OFF → ON
U1010: CONTROL UNIT (CAN)	<ul style="list-style-type: none"> <li>Right and left swivel motors stop at the position when DTC is detected.</li> <li>Right and left headlamp aiming motors stop at the position when DTC is detected.</li> </ul>	Blinks 1 second each.	Erasure DTC or Ignition switch OFF → ON
B2503: SWIVEL ACTUATOR [RH]	<ul style="list-style-type: none"> <li>Right swivel motors stop at the position when DTC is detected.</li> <li>The signal, approximately 2 V decreased from the levelizer signal when DTC detected, is output.</li> </ul>	Blinks 1 second each.	Erasure DTC or Ignition switch OFF → ON
B2504: SWIVEL ACTUATOR [LH]	<ul style="list-style-type: none"> <li>Left swivel motors stop at the position when DTC is detected.</li> <li>The signal, approximately 2 V decreased from the levelizer signal when DTC detected, is output.</li> </ul>	Blinks 1 second each.	Erasure DTC or Ignition switch OFF → ON
B2513: HI SEN UNUSUAL [FR]	<ul style="list-style-type: none"> <li>Right and left headlamp aiming motors stop at the position when DTC is detected.</li> </ul>	—	Erasure DTC or Ignition switch OFF → ON
B2514: HI SEN UNUSUAL [RR]	<ul style="list-style-type: none"> <li>Right and left headlamp aiming motors stop at the position when DTC is detected.</li> </ul>	—	Erasure DTC or Ignition switch OFF → ON
C0126: ST ANG SEN SIG	<ul style="list-style-type: none"> <li>Right and left swivel motor swivel angle returns to 0° and fixed.</li> </ul>	Blinks 1 second each.	Erasure DTC or Ignition switch OFF → ON
B2516: SHIFT SIG [P, R]	<ul style="list-style-type: none"> <li>Right and left swivel motor swivel angle returns to 0° and fixed.</li> </ul>	Blinks 1 second each.	Erasure DTC or Ignition switch OFF → ON
B2517: VEHICLE SPEED SIG	<ul style="list-style-type: none"> <li>Right and left swivel motor swivel angle returns to 0° and fixed.</li> <li>Right and left headlamp aiming motors stop at the position when DTC is detected.</li> </ul>	Blinks 1 second each.	Erasure DTC or Ignition switch OFF → ON
B2519: LEVELIZER CALIB	<ul style="list-style-type: none"> <li>Right and left headlamp aiming motors stop at the position when DTC is detected.</li> </ul>	—	When the levelizer adjustment is completed.



# SYSTEM

< SYSTEM DESCRIPTION >

[XENON TYPE]

DTC	Fail-safe	AFS OFF indicator lamp	Cancellation
C0428: ST ANGLE SEN CALIB	<ul style="list-style-type: none"> <li>Right and left swivel motor swivel angle returns to 0° and fixed.</li> </ul>	Blinks 1 second each.	When the steering angle sensor neutral position registration is completed.
B2521: ECU CIRC	<ul style="list-style-type: none"> <li>Right and left swivel motors stop at the position when DTC is detected.</li> <li>Right and left headlamp aiming motors stop at the position when DTC is detected.</li> </ul>	Blinks 1 second each.	Erase DTC or Ignition switch OFF → ON

## HEADLAMP AIMING CONTROL (MANUAL)

### HEADLAMP AIMING CONTROL (MANUAL) : System Description

INFOID:000000009010228

The headlamp levelizer adjusts the headlamp light axis upward and downward with the headlamp aiming motor integrated in the front combination lamp.

## TURN SIGNAL AND HAZARD WARNING LAMP SYSTEM

### TURN SIGNAL AND HAZARD WARNING LAMP SYSTEM : System Diagram

INFOID:000000009010229

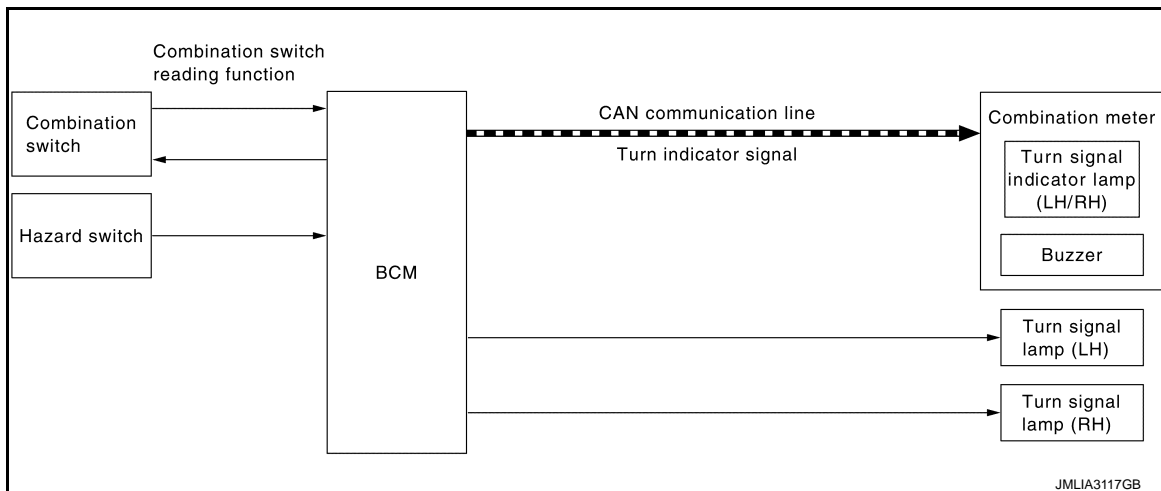

### TURN SIGNAL AND HAZARD WARNING LAMP SYSTEM : System Description

INFOID:000000009010230

#### OUTLINE

Turn signal and the hazard warning lamp is controlled by combination switch reading function, flasher control function and auto hazard function of BCM.

#### TURN SIGNAL LAMP OPERATION

- BCM detects the combination switch condition by the combination switch reading function.
- BCM supplies voltage to the right (left) turn signal lamp circuit when the ignition switch is turned ON and the turn signal switch is in the right (left) position. BCM blinks the turn signal lamp.

#### HAZARD WARNING LAMP OPERATION

BCM supplies voltage to both turn signal lamp circuit when the hazard switch is turned ON. BCM blinks the hazard warning lamp.

#### TURN SIGNAL INDICATOR LAMP AND TURN SIGNAL SOUND OPERATION

- BCM transmits the turn indicator signal to the combination meter via CAN communication while the turn signal lamp and the hazard warning lamp operating.
- Combination meter outputs the turn signal sound with the integrated buzzer while blinking the turn signal indicator lamp according to the turn indicator signal.

#### 3-TIME FLASHER FUNCTION

- By a short touch of the turn signal lever, BCM blinks the turn signal lamps 3 times in the selected direction.

A  
B  
C  
D  
E  
F  
G  
H  
I  
J  
K

EXL

M  
N  
O  
P

# SYSTEM

< SYSTEM DESCRIPTION >

[XENON TYPE]

- Cancels the operation when short touch of the turn signal lever in the reverse direction during the 3-time-flasher function operation.

## HIGH FLASHER OPERATION

- BCM detects the turn signal lamp circuit status from the current value.
- BCM increases the turn signal lamp blinking speed if the bulb or harness open is detected with the turn signal lamp operating.

### NOTE:

The blinking speed is normal while operating the hazard warning lamp.

## PARKING, LICENSE PLATE, SIDE MARKER AND TAIL LAMP SYSTEM

### PARKING, LICENSE PLATE, SIDE MARKER AND TAIL LAMP SYSTEM : System Diagram

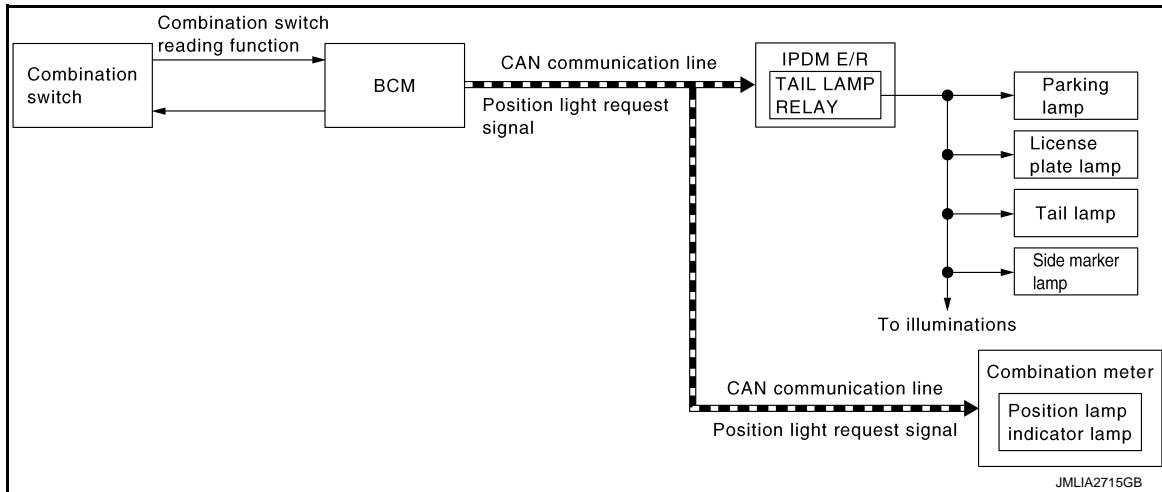

### PARKING, LICENSE PLATE, SIDE MARKER AND TAIL LAMP SYSTEM : System Description

INFOID:000000009010232

## OUTLINE

Parking, license plate, side marker and tail lamps are controlled by combination switch reading function and headlamp control function of BCM, and relay control function of IPDM E/R.

## PARKING, LICENSE PLATE, SIDE MARKER AND TAIL LAMPS OPERATION

- BCM detects the combination switch condition by the combination switch reading function.
- BCM transmits the position light request signal to IPDM E/R and the combination meter via CAN communication according to the ON/OFF condition of the parking, license plate, side marker and tail lamps.

Parking, license plate, side marker and tail lamps ON condition

- Lighting switch 1ST
- Lighting switch 2ND
- Lighting switch AUTO, and the auto light function ON judgment
- IPDM E/R turns the integrated tail lamp relay ON and turns the parking, license plate, side marker and tail lamps ON according to the position light request signal.
- Combination meter turns the position lamp indicator lamp ON according to the position light request signal.

## PARKING, LICENSE PLATE, SIDE MARKER AND TAIL LAMP SYSTEM : Fail-safe

INFOID:000000009010233

## CAN COMMUNICATION CONTROL

When CAN communication with BCM is impossible, IPDM E/R performs fail-safe control. After CAN communication recovers normally, it also returns to normal control.

If No CAN Communication Is Available With BCM

# SYSTEM

< SYSTEM DESCRIPTION >

[XENON TYPE]

Control part	Fail-safe operation
<ul style="list-style-type: none"> <li>• Parking lamps</li> <li>• License plate lamps</li> <li>• Illuminations</li> <li>• Tail lamps</li> </ul>	<ul style="list-style-type: none"> <li>• Turns ON the tail lamp relay and daytime running light relay* when the ignition switch is turned ON</li> <li>• Turns OFF the tail lamp relay and daytime running light relay* when the ignition switch is turned OFF</li> </ul>

\*: With daytime running light system

## FRONT FOG LAMP SYSTEM

### FRONT FOG LAMP SYSTEM : System Diagram

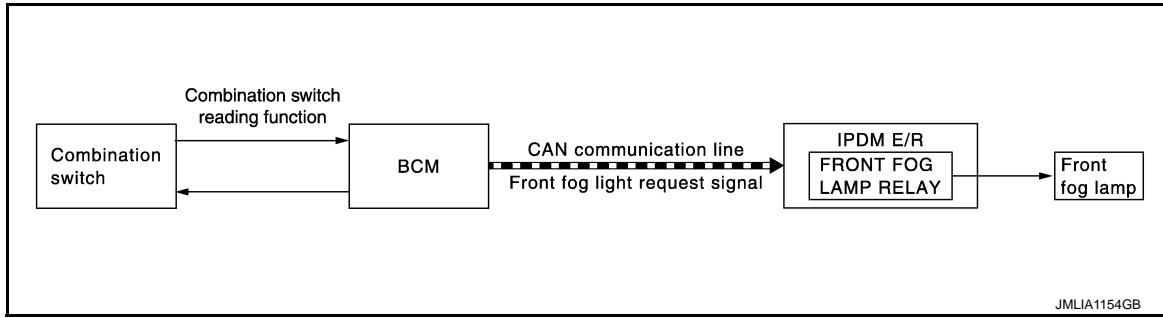

### FRONT FOG LAMP SYSTEM : System Description

INFOID:000000009010235

#### OUTLINE

Front fog lamp is controlled by combination switch reading function and front fog lamp control function of BCM, and relay control function of IPDM E/R.

#### FRONT FOG LAMP OPERATION

- BCM detects the combination switch condition by the combination switch reading function.
- BCM transmits the front fog lights request signal to IPDM E/R via CAN communication according to the front fog lamp ON condition.

Front fog lamp ON condition

- Front fog lamp switch ON and any of the followings. (except for the high beam ON)

- Lighting switch 2ND
- Lighting switch AUTO (auto light function ON judgment)

IPDM E/R turns the integrated front fog lamp relay ON, and turns the front fog lamp ON according to the front fog lights request signal.

### FRONT FOG LAMP SYSTEM : Fail-safe

INFOID:000000009010236

#### CAN COMMUNICATION CONTROL

When CAN communication with ECM and BCM is impossible, IPDM E/R performs fail-safe control. After CAN communication recovers normally, it also returns to normal control.

If No CAN Communication Is Available With BCM

Control part	Fail-safe operation
Front fog lamp	Front fog lamp relay OFF

## EXTERIOR LAMP BATTERY SAVER SYSTEM

# SYSTEM

< SYSTEM DESCRIPTION >

[XENON TYPE]

## EXTERIOR LAMP BATTERY SAVER SYSTEM : System Diagram

INFOID:000000009010237

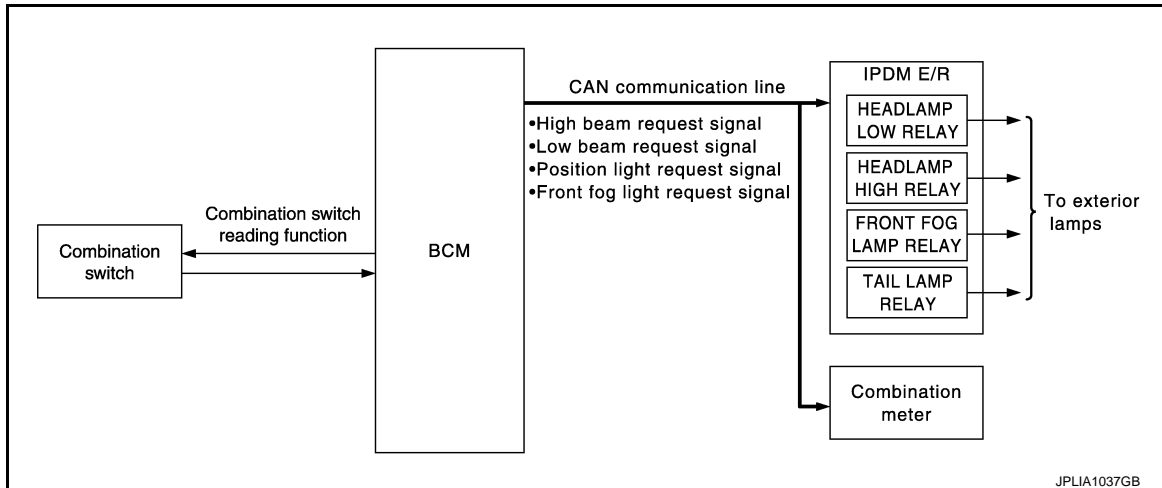

## EXTERIOR LAMP BATTERY SAVER SYSTEM : System Description

INFOID:000000009010238

### OUTLINE

- Exterior lamp battery saver system is controlled by each function of BCM and IPDM E/R.

#### Control by BCM

- Combination switch reading function
- Headlamp control function
- Exterior lamp battery saver function

#### Control by IPDM E/R

- Relay control function
  - BCM turns the exterior lamp\* OFF after a period of time to prevent the battery from over-discharge when the ignition switch is turned OFF with the exterior lamp ON.
- \*: Headlamp (LO/HI), parking lamp, tail lamp, side marker lamp, license plate lamp and front fog lamp

### EXTERIOR LAMP BATTERY SAVER ACTIVATION

BCM activates the timer and turns the exterior lamp OFF 5 minutes after the ignition switch is turned from ON → OFF with the exterior lamps ON.

#### NOTE:

- Headlamp control function turns the exterior lamps ON normally when the ignition switch is turned ACC or the engine started (both before and after the exterior lamp battery saver is turned OFF).
- The timer starts at the time that the lighting switch is turned from OFF → 1ST or 2ND with the exterior lamp OFF.

# DIAGNOSIS SYSTEM (BCM)

< SYSTEM DESCRIPTION >

[XENON TYPE]

## DIAGNOSIS SYSTEM (BCM)

### COMMON ITEM

### COMMON ITEM : CONSULT Function (BCM - COMMON ITEM)

INFOID:000000009355171

### APPLICATION ITEM

CONSULT performs the following functions via CAN communication with BCM.

Diagnosis mode	Function Description
Work Support	Changes the setting for each system function.
Self Diagnostic Result	Displays the diagnosis results judged by BCM. Refer to <a href="#">BCS-57, "DTC Index"</a> .
CAN Diag Support Monitor	Monitors the reception status of CAN communication viewed from BCM.
Data Monitor	The BCM input/output signals are displayed.
Active Test	The signals used to activate each device are forcibly supplied from BCM.
Ecu Identification	The BCM part number is displayed.
Configuration	<ul style="list-style-type: none"> <li>Read and save the vehicle specification.</li> <li>Write the vehicle specification when replacing BCM.</li> </ul>

### SYSTEM APPLICATION

BCM can perform the following functions for each system.

#### NOTE:

It can perform the diagnosis modes except the following for all sub system selection items.

x: Applicable item

System	Sub system selection item	Diagnosis mode		
		Work Support	Data Monitor	Active Test
Door lock	DOOR LOCK	×	×	×
Rear window defogger	REAR DEFOGGER		×	×
Warning chime	BUZZER		×	×
Interior room lamp timer	INT LAMP	×	×	×
Exterior lamp	HEAD LAMP	×	×	×
Wiper and washer	WIPER	×	×	×
Turn signal and hazard warning lamps	FLASHER	×	×	×
—	AIR CONDITONER*		×	×
<ul style="list-style-type: none"> <li>Intelligent Key system</li> <li>Engine start system</li> </ul>	INTELLIGENT KEY	×	×	×
Combination switch	COMB SW		×	
Body control system	BCM	×		
IVIS	IMMU	×	×	×
Interior room lamp battery saver	BATTERY SAVER	×	×	×
Back door	TRUNK		×	
Vehicle security system	THEFT ALM	×	×	×
RAP system	RETAINED PWR		×	
Signal buffer system	SIGNAL BUFFER		×	×
—	AIR PRESSURE MONITOR*	×	×	×

\*: This item is indicated, but not used.

### FREEZE FRAME DATA (FFD)

The BCM records the following vehicle condition at the time a particular DTC is detected, and displays on CONSULT.

# DIAGNOSIS SYSTEM (BCM)

[XENON TYPE]

## < SYSTEM DESCRIPTION >

CONSULT screen item	Indication/Unit	Description
Vehicle Speed	km/h	Vehicle speed of the moment a particular DTC is detected
Odo/Trip Meter	km	Total mileage (Odometer value) of the moment a particular DTC is detected
Vehicle Condition	SLEEP>LOCK	While turning BCM status from low power consumption mode to normal mode (Power supply position is "LOCK")
	SLEEP>OFF	While turning BCM status from low power consumption mode to normal mode (Power supply position is "OFF".)
	LOCK>ACC	While turning power supply position from "LOCK" to "ACC"
	ACC>ON	While turning power supply position from "ACC" to "IGN"
	RUN>ACC	While turning power supply position from "RUN" to "ACC" (Vehicle is stopping and selector lever is except P position.)
	CRANK>RUN	While turning power supply position from "CRANKING" to "RUN" (From cranking up the engine to run it)
	RUN>URGENT	While turning power supply position from "RUN" to "ACC" (Emergency stop operation)
	ACC>OFF	While turning power supply position from "ACC" to "OFF"
	OFF>LOCK	While turning power supply position from "OFF" to "LOCK"
	OFF>ACC	While turning power supply position from "OFF" to "ACC"
	ON>CRANK	While turning power supply position from "IGN" to "CRANKING"
	OFF>SLEEP	While turning BCM status from normal mode (Power supply position is "OFF".) to low power consumption mode
	LOCK>SLEEP	While turning BCM status from normal mode (Power supply position is "LOCK".) to low power consumption mode
	LOCK	Power supply position is "LOCK" (Ignition switch OFF with steering is locked.)
	OFF	Power supply position is "OFF" (Ignition switch OFF with steering is unlocked.)
	ACC	Power supply position is "ACC" (Ignition switch ACC)
ON	Power supply position is "IGN" (Ignition switch ON with engine stopped)	
ENGINE RUN	Power supply position is "RUN" (Ignition switch ON with engine running)	
CRANKING	Power supply position is "CRANKING" (At engine cranking)	
IGN Counter	0 - 39	<p>The number of times that ignition switch is turned ON after DTC is detected</p> <ul style="list-style-type: none"> <li>The number is 0 when a malfunction is detected now.</li> <li>The number increases like 1 → 2 → 3...38 → 39 after returning to the normal condition whenever ignition switch OFF → ON.</li> <li>The number is fixed to 39 until the self-diagnosis results are erased if it is over 39.</li> </ul>

## HEADLAMP

### HEADLAMP : CONSULT Function (BCM - HEAD LAMP)

INFOID:000000009010240

### WORK SUPPORT

Service item	Setting item	Setting
CUSTOM A/LIGHT SETTING	MODE 1*1	Normal
	MODE 2	More sensitive setting than normal setting (Turns ON earlier than normal operation)
	MODE 3	More sensitive setting than MODE 2 (Turns ON earlier than MODE 2)
	MODE 4	Less sensitive setting than normal setting (Turns ON later than normal operation)

# DIAGNOSIS SYSTEM (BCM)

< SYSTEM DESCRIPTION >

[XENON TYPE]

Service item	Setting item	Setting	
BATTERY SAVER SET	On*1	With the exterior lamp battery saver function	A
	Off	Without the exterior lamp battery saver function	
ILL DELAY SET	MODE 1*1	45 sec.	B
	MODE 2	Without the function	
	MODE 3	30 sec.	C
	MODE 4	60 sec.	
	MODE 5	90 sec.	D
	MODE 6	120 sec.	
	MODE 7	150 sec.	E
	MODE 8	180 sec.	
		Sets delay timer function timer operation time (All doors closed)	
AUTO LIGHT LOGIC SET*2	MODE 1*1	With twilight ON custom & with wiper INT, LO and HI	
	MODE 2	With twilight ON custom & with wiper LO and HI	F
	MODE 3	With twilight ON custom & without	
	MODE 4	Without twilight ON custom & with wiper INT, LO and HI	G
	MODE 5	Without twilight ON custom & with wiper LO and HI	
	MODE 6	Without twilight ON custom & without	

\*1: Factory setting

\*2: For models for Canada, this item is displayed but is not operated.

## DATA MONITOR

### NOTE:

The following table includes information (items) inapplicable to this vehicle. For information (items) applicable to this vehicle, refer to CONSULT display items.

Monitor item [Unit]	Description
PUSH SW [On/Off]	Indicates [On/Off] condition of push-button ignition switch
ENGINE STATE [Stop/Stall/Crank/Run]	Indicates [Stop/Stall/Crank/Run] condition of engine states
VEH SPEED 1 [km/h]	Display the vehicle speed signal received from combination meter by numerical value [Km/h]

EXL

# DIAGNOSIS SYSTEM (BCM)

[XENON TYPE]

## < SYSTEM DESCRIPTION >

Monitor item [Unit]	Description
TURN SIGNAL R [On/Off]	Each switch status that BCM judges from the combination switch reading function
TURN SIGNAL L [On/Off]	
TAIL LAMP SW [On/Off]	
HI BEAM SW [On/Off]	
HEAD LAMP SW1 [On/Off]	
HEAD LAMP SW2 [On/Off]	
PASSING SW [On/Off]	
AUTO LIGHT SW [On/Off]	
FR FOG SW [On/Off]	
RR FOG SW [Off]	
DOOR SW-DR [On/Off]	Indicated [On/Off] condition of front door switch (driver side)
DOOR SW-AS [On/Off]	Indicated [On/Off] condition of front door switch (passenger side)
DOOR SW-RR [On/Off]	Indicated [On/Off] condition of rear door switch RH
DOOR SW- RL [On/Off]	Indicated [On/Off] condition of rear door switch LH
DOOR SW-BK [On/Off]	Indicated [On/Off] condition of back door switch
OPTICAL SENSOR [Off]	<b>NOTE:</b> This item is displayed, but cannot be monitored
OPTI SEN (DTCT) [V]	The value of outside brightness voltage input from the optical sensor
OPTI SEN (FILT) [V]	The value of outside brightness voltage filtered by BCM

## ACTIVE TEST

Test item	Operation	Description
TAIL LAMP	On	Transmits the position light request signal to IPDM E/R via CAN communication to turn the tail lamp ON
	Off	Stops the tail lamp request signal transmission
HEAD LAMP	Hi	Transmits the high beam request signal via CAN communication to turn the headlamp (HI)
	Lo	Transmits the low beam request signal via CAN communication to turn the headlamp (LO)
	Off	Stops the high & low beam request signal transmission
FR FOG LAMP	On	Transmits the front fog lights request signal to IPDM E/R via CAN communication to turn the front fog lamp ON
	Off	Stops the front light request signal transmission



# DIAGNOSIS SYSTEM (BCM)

< SYSTEM DESCRIPTION >

[XENON TYPE]

Test item	Operation	Description
RR FOG LAMP	On	<b>NOTE:</b> This item is indicated, but can not tested
	Off	
DAYTIME RUNNING LIGHT*	On	Transmits the front fog lights request signal to IPDM E/R via CAN communication to turn the front fog lamp ON (daytime running light system)
	Off	Stops the front light request signal transmission (daytime running light system)
ILL DIM SIGNAL	On	<ul style="list-style-type: none"> <li>• Transmits the dimmer signal to combination meter via CAN communication and dims combination meter</li> <li>• Transmits the dimmer signal to AV control unit and dims display</li> </ul>
	Off	Stops the dimmer signal transmission

\*: Only models for Canada display this item.

## FLASHER

### FLASHER : CONSULT Function (BCM - FLASHER)

INFOID:000000009010241

#### WORK SUPPORT

Service item	Setting item	Setting	
HAZARD ANSWER BACK	Lock Only	With locking only	Sets the hazard warning lamp answer back function when the door is lock/unlock with the request switch or the key fob.
	Unlk Only	With unlocking only	
	Lock&Unlk*	With locking/unlocking	
	Off	Without the function	

\*: Factory setting

#### DATA MONITOR

##### NOTE:

The following table includes information (items) inapplicable to this vehicle. For information (items) applicable to this vehicle, refer to CONSULT display items.

Monitor item [Unit]	Description
REQ SW-DR [On/Off]	Indicates [On/Off] condition of door request switch (driver side)
REQ SW-AS [On/Off]	Indicates [On/Off] condition of door request switch (passenger side)
PUSH SW [On/Off]	Indicates [On/Off] condition of push-button ignition switch
TURN SIGNAL R [On/Off]	Each switch status that BCM detects from the combination switch reading function
TURN SIGNAL L [On/Off]	
HAZARD SW [On/Off]	The switch status input from the hazard switch
RKE-LOCK [On/Off]	Indicates [On/Off] condition of LOCK signal from Intelligent Key
RKE-UNLOCK [On/Off]	Indicates [On/Off] condition of UNLOCK signal from Intelligent Key
RKE-PANIC [On/Off]	Indicates [On/Off] condition of PANIC button of Intelligent Key

#### ACTIVE TEST

# DIAGNOSIS SYSTEM (BCM)

< SYSTEM DESCRIPTION >

[XENON TYPE]

Test item	Operation	Description
FLASHER	RH	Outputs the voltage to turn the right side turn signal lamps ON.
	LH	Outputs the voltage to turn the left side turn signal lamps ON.
	Off	Stops the voltage to turn the turn signal lamps OFF.

## DIAGNOSIS SYSTEM (IPDM E/R)

### Diagnosis Description

INFOID:000000009355172

### AUTO ACTIVE TEST

#### Description

In auto active test, the IPDM E/R sends a drive signal to the following systems to check their operation.

- Oil pressure warning lamp
- Rear window defogger
- Front wiper (LO, HI)
- Parking lamp
- License plate lamp
- Tail lamp
- Side marker lamp
- Front fog lamp
- Headlamp (LO, HI)
- A/C compressor (magnet clutch)

#### Operation Procedure

#### CAUTION:

**Never perform auto active test in the following conditions.**

- Engine is running.
- CONSULT is connected.

1. Close the hood and lift the wiper arms from the windshield. (Prevent windshield damage due to wiper operation)

#### NOTE:

When auto active test is performed with hood opened, sprinkle water on windshield beforehand.

2. Turn the ignition switch OFF.
3. Turn the ignition switch ON, and within 20 seconds, press the driver door switch 10 times. Then turn the ignition switch OFF.

#### CAUTION:

**Close passenger door.**

4. Turn the ignition switch ON within 10 seconds. After that the horn sounds once and the auto active test starts.

#### CAUTION:

**Engine starts when ignition switch is turned ON while brake pedal is depressed.**

5. The oil pressure warning lamp starts blinking when the auto active test starts.
6. After a series of the following operations is repeated 3 times, auto active test is completed.

#### NOTE:

- When auto active test has to be cancelled halfway through test, turn the ignition switch OFF.
- When auto active test is not activated, door switch may be the cause. Check door switch. Refer to [DLK-119](#), "[Component Function Check](#)".

#### Inspection in Auto Active Test

When auto active test is actuated, the following operation sequence is repeated 3 times.

Operation sequence	Inspection location	Operation
1	Oil pressure warning lamp	Blinks continuously during operation of auto active test
2	Rear window defogger	10 seconds
3	Front wiper	LO for 5 seconds → HI for 5 seconds
4	<ul style="list-style-type: none"> <li>• Parking lamp</li> <li>• License plate lamp</li> <li>• Tail lamp</li> <li>• Side marker lamp</li> <li>• Front fog lamp</li> </ul>	10 seconds

# DIAGNOSIS SYSTEM (IPDM E/R)

< SYSTEM DESCRIPTION >

[XENON TYPE]

Operation sequence	Inspection location	Operation
5	Headlamp	LO for 10 seconds → HI ON ↔ OFF 5 times
6	A/C compressor (magnet clutch)	ON ↔ OFF 5 times

Concept of auto active test

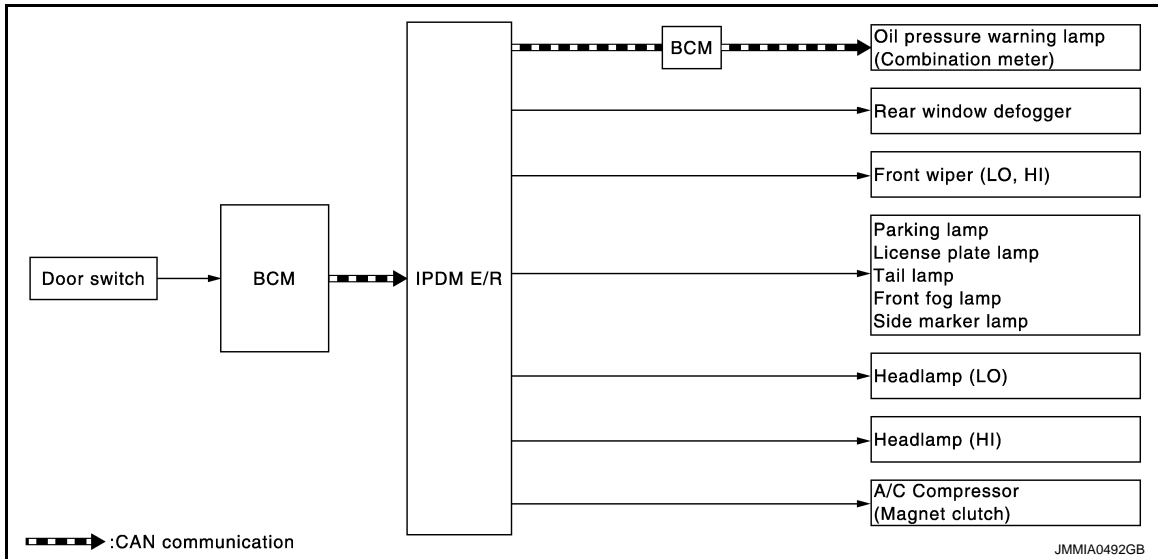

- IPDM E/R starts the auto active test with the door switch signals transmitted by BCM via CAN communication. Therefore, the CAN communication line between IPDM E/R and BCM is considered normal if the auto active test starts successfully.
- The auto active test facilitates troubleshooting if any systems controlled by IPDM E/R cannot be operated.

Diagnosis chart in auto active test

Symptom	Inspection contents		Possible cause
Rear window defogger does not operate	Perform auto active test. Does the rear window defogger operate?	YES	BCM signal input circuit
		NO	<ul style="list-style-type: none"> <li>• Rear window defogger</li> <li>• Rear window defogger ground circuit</li> <li>• Harness or connector between IPDM E/R and rear window defogger</li> <li>• IPDM E/R</li> </ul>
Any of the following components do not operate <ul style="list-style-type: none"> <li>• Parking lamp</li> <li>• License plate lamp</li> <li>• Tail lamp</li> <li>• Side marker lamp</li> <li>• Front fog lamp</li> <li>• Headlamp (HI, LO)</li> <li>• Front wiper (HI, LO)</li> </ul>	Perform auto active test. Does the applicable system operate?	YES	BCM signal input circuit
		NO	<ul style="list-style-type: none"> <li>• Lamp or motor</li> <li>• Lamp or motor ground circuit</li> <li>• Harness or connector between IPDM E/R and applicable system</li> <li>• IPDM E/R</li> </ul>
A/C compressor does not operate	Perform auto active test. Does the magnet clutch operate?	YES	<ul style="list-style-type: none"> <li>• A/C auto amp. signal input circuit</li> <li>• CAN communication signal between A/C auto amp. and ECM</li> <li>• CAN communication signal between ECM and IPDM E/R</li> </ul>
		NO	<ul style="list-style-type: none"> <li>• Magnet clutch</li> <li>• Harness or connector between IPDM E/R and magnet clutch</li> <li>• IPDM E/R</li> </ul>

# DIAGNOSIS SYSTEM (IPDM E/R)

< SYSTEM DESCRIPTION >

[XENON TYPE]

Symptom	Inspection contents	Possible cause
Oil pressure warning lamp does not operate	Perform auto active test. Does the oil pressure warning lamp blink?	YES <ul style="list-style-type: none"> <li>Harness or connector between IPDM E/R and oil pressure switch</li> <li>Oil pressure switch</li> <li>IPDM E/R</li> </ul>
		NO <ul style="list-style-type: none"> <li>CAN communication signal between IPDM E/R and BCM</li> <li>CAN communication signal between BCM and combination meter</li> <li>Combination meter</li> </ul>

## CONSULT Function (IPDM E/R)

INFOID:000000009355173

### APPLICATION ITEM

CONSULT performs the following functions via CAN communication with IPDM E/R.

Diagnosis mode	Description
Ecu Identification	Allows confirmation of IPDM E/R part number.
Self Diagnostic Result	Displays the diagnosis results judged by IPDM E/R.
Data Monitor	Displays the real-time input/output data from IPDM E/R input/output data.
Active Test	IPDM E/R can provide a drive signal to electronic components to check their operations.
CAN Diag Support Monitor	The results of transmit/receive diagnosis of CAN communication can be read.

### SELF DIAGNOSTIC RESULT

Refer to [PCS-22, "DTC Index"](#).

### DATA MONITOR

#### NOTE:

The following table includes information (items) inapplicable to this vehicle. For information (items) applicable to this vehicle, refer to CONSULT display items.

Monitor Item [Unit]	MAIN SIGNALS	Description
RAD FAN REQ [1/2/3/4]	×	Displays the value of the cooling fan speed request signal received from ECM via CAN communication.
AC COMP REQ [Off/On]	×	Displays the status of the A/C compressor request signal received from ECM via CAN communication.
TAIL&CLR REQ [Off/On]	×	Displays the status of the position light request signal received from BCM via CAN communication.
HL LO REQ [Off/On]	×	Displays the status of the low beam request signal received from BCM via CAN communication.
HL HI REQ [Off/On]	×	Displays the status of the high beam request signal received from BCM via CAN communication.
FR FOG REQ [Off/On]	×	Displays the status of the front fog light request signal received from BCM via CAN communication.
FR WIP REQ [Stop/1LOW/Low/Hi]	×	Displays the status of the front wiper request signal received from BCM via CAN communication.
WIP AUTO STOP [STOP P/ACT P]	×	Displays the status of the front wiper auto stop signal judged by IPDM E/R.
WIP PROT [Off/BLOCK]	×	Displays the status of the front wiper fail-safe operation judged by IPDM E/R.
IGN RLY1 -REQ [Off/On]		Displays the status of the ignition switch ON signal received from BCM via CAN communication.

# DIAGNOSIS SYSTEM (IPDM E/R)

[XENON TYPE]

## < SYSTEM DESCRIPTION >

Monitor Item [Unit]	MAIN SIG- NALS	Description
IGN RLY [Off/On]	×	Displays the status of the ignition relay judged by IPDM E/R.
PUSH SW [Off/On]		Displays the status of the push-button ignition switch judged by IPDM E/R.
INTER/NP SW [Off/On]		Displays the status of the shift position judged by IPDM E/R.
ST RLY CONT [Off/On]		Displays the status of the starter relay status signal received from BCM via CAN communication.
IHBT RLY -REQ [Off/On]		Displays the status of the starter control relay signal received from BCM via CAN communication.
ST/INHI RLY [Off/ ST ON/INHI ON/UNKWN]		Displays the status of the starter relay and starter control relay judged by IPDM E/R.
DETENT SW [Off/On]		Displays the status of the A/T shift selector (detention switch) judged by IPDM E/R.
S/L RLY -REQ [Off/On]		<b>NOTE:</b> The item is indicated, but not monitored.
S/L STATE [LOCK/UNLK/UNKWN]		<b>NOTE:</b> The item is indicated, but not monitored.
OIL P SW [Open/Close]		Displays the status of the oil pressure switch judged by IPDM E/R.
HOOD SW [Off/On]		Displays the status of the hood switch 1 judged by IPDM E/R.
HL WASHER REQ [Off/On]		Displays the status of the headlamp washer request signal received from BCM via CAN communication.
THFT HRN REQ [Off/On]		Displays the status of the theft warning horn request signal received from BCM via CAN communication.
HORN CHIRP [Off/On]		Displays the status of the horn reminder signal received from BCM via CAN communication.
HOOD SW 2 [Off/On]		Displays the status of the hood switch 2 judged by IPDM E/R.

## ACTIVE TEST

Test item	Operation	Description
CORNERING LAMP	LH	<b>NOTE:</b> This item is indicated, but cannot be tested.
	RH	
HORN	On	Operates horn relay for 20 ms.
REAR DEFOGGER	Off	OFF
	On	Operates the rear window defogger relay.
FRONT WIPER	Off	OFF
	Lo	Operates the front wiper relay.
	Hi	Operates the front wiper relay and front wiper high relay.
MOTOR FAN*	1	OFF
	2	Transmits 50% pulse duty signal (PWM signal) to the cooling fan control module.
	3	Transmits 75% pulse duty signal (PWM signal) to the cooling fan control module.
	4	Transmits 100% pulse duty signal (PWM signal) to the cooling fan control module.
HEAD LAMP WASHER	On	Operates the headlamp washer relay for 1 second.

# DIAGNOSIS SYSTEM (IPDM E/R)

< SYSTEM DESCRIPTION >

[XENON TYPE]

Test item	Operation	Description
EXTERNAL LAMPS	Off	OFF
	TAIL	Operates the tail lamp relay.
	Lo	Operates the headlamp low relay.
	Hi	Operates the headlamp low relay and ON/OFF the headlamp high relay at 1 second intervals.
	Fog	Operates the front fog lamp relay.

\*: Operates while the engine is running.

A  
B  
C  
D  
E  
F  
G  
H  
I  
J  
K  
L  
M  
N  
O  
P

EXL

# DIAGNOSIS SYSTEM (AFS)

[XENON TYPE]

< SYSTEM DESCRIPTION >

## DIAGNOSIS SYSTEM (AFS)

### CONSULT Function (ADAPTIVE LIGHT)

INFOID:000000009010244

#### APPLICATION ITEM

Diagnostic mode	Description
Ecu Identification	Allows confirmation of AFS control unit part number.
Self Diagnostic Result	Displays the diagnosis results judged by AFS control unit.
Work support	Sets each sensor.
Data monitor	Indicates AFS control unit input data in real time.
Active test	Provides the drive signal to the load. Checks operation.

#### WORK SUPPORT

Service item	Description
ST ANG SEN ADJUSTMENT*	—
LEVELIZER ADJUSTMENT	Adjusts the height sensor signal output value (AFS control unit recognized) in the unloaded vehicle condition.

\*: Adjusts the steering angle sensor neutral position on ABS actuator and electrical unit (control unit) side. Refer to [BRC-62. "Work Procedure"](#).

#### DATA MONITOR

##### NOTE:

The following table includes information (items) inapplicable to this vehicle. For information (items) applicable to this vehicle, refer to CONSULT display items.

Monitor item [Unit]	Description
STR ANGLS SIG [deg]	The steering angle value judged by the steering angle sensor signal received from the steering angle sensor via CAN communication
VHCL SPD [km/h]	The vehicle speed signal value from the combination meter via CAN communication
SLCT LVR POSI [P/R/N/D/M/FF]	The selector lever status judged by the position indicator signal received from TCM via CAN communication
HEAD LAMP [On/Off]	The headlamp On/Off status judged by the low beam headlamp (ON) signal received from IPDM E/R via CAN communication
AFS SW [Off]	<b>NOTE:</b> This item is indicated, but can not monitored
HI SEN OTP RR [V]	The rear height sensor signal voltage value input from the rear height sensor
HI SEN OTP FR [V]	The front height sensor signal voltage value input from the front height sensor
LEV ACTR VLTG [%]	The ratio value to the battery voltage generated by the levelizer activation signal control value judged by AFS control unit
SWVL SEN RH* [deg]	The head lamp swivel angle value judged by AFS control unit received from the swivel position sensor signal input from the swivel actuator
SWVL SEN LH* [deg]	
SWVL ANGLE RH* [deg]	The swivel angle command value to the swivel motor judged by AFS control unit
SWVL ANGLE LH* [deg]	



# DIAGNOSIS SYSTEM (AFS)

[XENON TYPE]

< SYSTEM DESCRIPTION >

\*: The swivel angle "0°" (feedback value) of the swivel position sensor signal may differ from the swivel angle "0°" of the swivel motor (AFS control unit command value). This causes that the swivel motor initializes the value based on the step number from the stopper.

**ACTIVE TEST**

**NOTE:**

Start the engine when using "ACTIVE TEST".

Test item	Operation Item	Description
LOW BEAM TEST RIGHT	Origin Fast	Swivels the right headlamp to the swivel angle 0° in the normal speed.
	Peak Fast	Swivels the right headlamp to the swivel angle approximately 15° in the normal speed.
	Origin Slow	Swivels the right headlamp to the swivel angle 0° in the speed at the initialization.
	Peak Slow	Swivels the right headlamp to the swivel angle approximately 15° in the speed at the initialization.
LOW BEAM TEST LEFT	Origin Fast	Swivels the left headlamp to the swivel angle 0° in the normal speed.
	Peak Fast	Swivels the left headlamp to the swivel angle approximately 17° in the normal speed.
	Origin Slow	Swivels the left headlamp to the swivel angle 0° in the speed at the initialization.
	Peak Slow	Swivels the left headlamp to the swivel angle approximately 17° in the speed at the initialization.
LEVELIZER TEST	Origin	Changes the aiming motor drive signal to approximately 70% of the battery voltage. Moves the headlamp upward and downward.
	Peak	Changes the aiming motor drive signal to approximately 15% of the battery voltage. Moves the headlamp upward and downward.

**NOTE:**

"Fast" operation speed is as three times fast as "Slow".

A  
B  
C  
D  
E  
F  
G  
H  
I  
J  
K  
L  
M  
N  
O  
P

EXL

# ECU DIAGNOSIS INFORMATION

## BCM, IPDM E/R

### List of ECU Reference

INFOID:000000009010245

ECU	Reference
BCM	<a href="#">BCS-35, "Reference Value"</a>
	<a href="#">BCS-56, "Fail-safe"</a>
	<a href="#">BCS-57, "DTC Inspection Priority Chart"</a>
	<a href="#">BCS-57, "DTC Index"</a>
IPDM E/R	<a href="#">PCS-15, "Reference Value"</a>
	<a href="#">PCS-20, "Fail-safe"</a>
	<a href="#">PCS-22, "DTC Index"</a>

# AFS CONTROL UNIT

< ECU DIAGNOSIS INFORMATION >

[XENON TYPE]

## AFS CONTROL UNIT

### Reference Value

INFOID:000000009010246

### VALUES ON THE DIAGNOSIS TOOL

**NOTE:**

The following table includes information (items) inapplicable to this vehicle. For information (items) applicable to this vehicle, refer to CONSULT display items.

CONSULT MONITOR ITEM

Monitor Item	Condition		Value/Status
STR ANGLE SIG	Steering	Straight-forward	Approx. 0°
		Steering	Approx. -900° - +900°
VHCL SPD	Driving at 40 km/h (25 MPH)		40 km/h
SLCT LVR POSI	Selector lever operation		P - 1
HEAD LAMP	Light switch	2ND	On
		Other than 2ND	Off
AFS SW	<b>NOTE:</b> This item is indicated, but can not monitored		Off
HI SEN OTP FR	Vehicle front height	Unloaded vehicle condition	Approx. 3.5 V
		Low (Leveling operation downward edge)	Approx. 1.6 V
HI SEN OTP RR	Vehicle rear height	Unloaded vehicle condition	Approx. 3.2 V
		Low (Leveling operation downward edge)	Approx. 1.5 V
LEV ACTR VLTG	Headlamp leveling	Unloaded vehicle condition	Approx. 60.0%
		Low (Leveling operation downward edge)	Approx. 58.7%
SWVL SEN RH	Right headlamp swivel activation	Standard position	Approx. 0°
		Activation	Positive degree (+°)
SWVL SEN LH	Left headlamp swivel activation	Standard position	Approx. 0°
		Activation	Positive degree (+°)
SWVL ANGLE RH	Right headlamp swivel activation	Standard position	Approx. 0°
		Activation	Positive degree (+°)
SWVL ANGLE LH	Left headlamp swivel activation	Standard position	Approx. 0°
		Activation	Positive degree (+°)

### TERMINAL LAYOUT

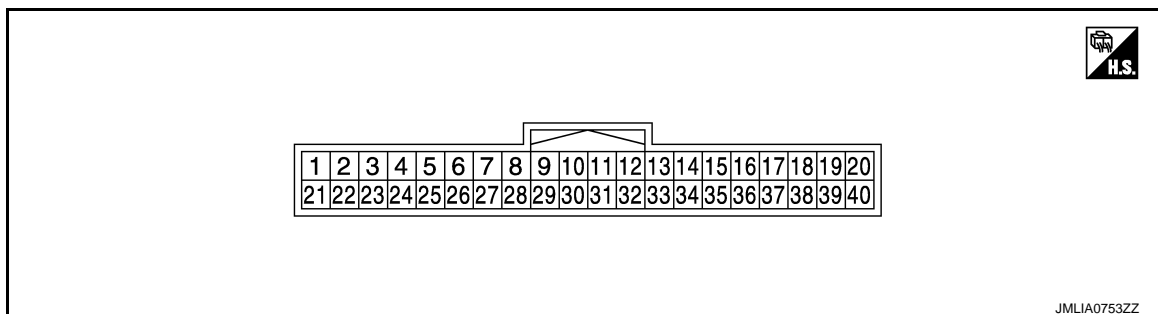

### PHYSICAL VALUES

# AFS CONTROL UNIT

< ECU DIAGNOSIS INFORMATION >

[XENON TYPE]

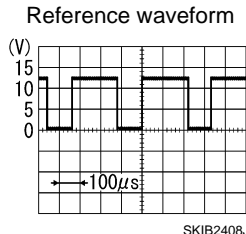
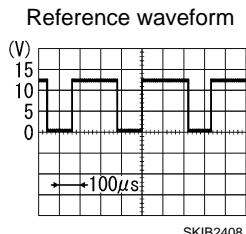
Terminal No. (Wire color)		Description		Condition		Value (Approx.)
+	-	Signal name	Input/ output			
1 (GR)	Ground	Ignition power supply	Input	The ignition switch ON		Battery voltage
2 (LG/B)	Ground	Right swivel position sensor ground	Input	The ignition switch ON		0 V
4 (Y/R)	Ground	Right swivel position sensor power supply	Output	The ignition switch ON		5 V
5 (L/Y)	Ground	Front height sensor power supply	Output	The ignition switch ON		5 V
6 (LG/R)	Ground	Rear height sensor power supply	Output	The ignition switch ON		5 V
7 (P)	Ground	CAN-L	Input/ output	—		—
8 (B/O)	Ground	Rear height sensor ground	Input	The ignition switch ON		0 V
9 (GR)	Ground	Right swivel position sensor signal	Output	Right headlamp swivel angle	0°	1.0 V
					15°	2.8 V
10 (B/W)	Ground	Front height sensor ground	Input	The ignition switch ON		0 V
11 (R)	Ground	Right swivel motor 1-phase (-)	Output	Right headlamp swivel	Activation	<div style="text-align: right;">Reference waveform</div>  8 - 12 V
13 (B)	Ground	Right swivel motor 2-phase (-)	Output	Right headlamp swivel	Stopped	9.5 - 11.5 V
15 (W)	Ground	Left swivel motor 1-phase (+)	Output	Left headlamp swivel	Activation	<div style="text-align: right;">Reference waveform</div>  8 - 12 V
17 (G)	Ground	Left swivel motor 2-phase (+)	Output	Left headlamp swivel	Stopped	9.5 - 11.5 V
19 (SB)	Ground	Right levelizer signal	Output	Right headlamp leveling	Unloaded vehicle condition	7.5 V
					Leveling operation downward edge	7.3 V

# AFS CONTROL UNIT

< ECU DIAGNOSIS INFORMATION >

[XENON TYPE]

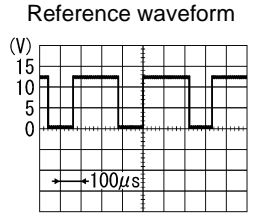
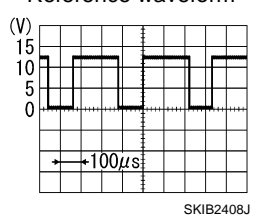
Terminal No. (Wire color)		Description		Condition	Value (Approx.)
+	-	Signal name	Input/ output		
23 (V)	Ground	Front height sensor signal	Output	Vehicle rear height	Unloaded vehicle condition
					3.5 V
					Low (Leveling operation downward edge)
					1.6 V
24 (L/O)	Ground	Left swivel position sensor power supply	Output	The ignition switch ON	5 V
25 (B)	Ground	Ground	—	The ignition switch ON	0 V
27 (BR/Y)	Ground	Left swivel position sensor ground	Input	The ignition switch ON	0 V
28 (R/G)	Ground	Rear height sensor signal	Output	Vehicle rear height	Unloaded vehicle condition
					3.2 V
					Low (Leveling operation downward edge)
					1.5 V
29 (BR/W)	Ground	Left swivel position sensor signal	Output	Left headlamp swivel angle	0°
					17°
					1.0 V
					3.0 V
30 (L)	Ground	CAN-H	Input/ output	—	—
32 (G)	Ground	Right swivel motor 2-phase (+)	Output	Right headlamp swivel	Activation
					
					8 - 12 V
34 (W)	Ground	Right swivel motor 1-phase (+)	Output	Right headlamp swivel	Stopped
					9.5 - 11.5 V
36 (R)	Ground	Left swivel motor 2-phase (-)	Output	Left headlamp swivel	Activation
					
					8 - 12 V
38 (B)	Ground	Left swivel motor 1-phase (-)	Output	Left headlamp swivel	Stopped
					9.5 - 11.5 V
40 (GR/L)	Ground	Left levelizer signal	Output	Right headlamp leveling	Unloaded vehicle condition
					7.5 V
					Leveling operation downward edge
					7.3 V

A  
B  
C  
D  
E  
F  
G  
H  
I  
J  
K  
M  
N  
O  
P

EXL

# AFS CONTROL UNIT

< ECU DIAGNOSIS INFORMATION >

[XENON TYPE]

## Fail-safe

INFOID:000000009010247

DTC	Fail-safe	AFS OFF indicator lamp	Cancellation
U1000: CAN COMM CIRCUIT	<ul style="list-style-type: none"> <li>• Right and left swivel motors stop at the position when DTC is detected.</li> <li>• Right and left headlamp aiming motors stop at the position when DTC is detected.</li> </ul>	Blinks 1 second each.	Erase DTC or Ignition switch OFF → ON
U1010: CONTROL UNIT (CAN)	<ul style="list-style-type: none"> <li>• Right and left swivel motors stop at the position when DTC is detected.</li> <li>• Right and left headlamp aiming motors stop at the position when DTC is detected.</li> </ul>	Blinks 1 second each.	Erase DTC or Ignition switch OFF → ON
B2503: SWIVEL ACTUATOR [RH]	<ul style="list-style-type: none"> <li>• Right swivel motors stop at the position when DTC is detected.</li> <li>• The signal, approximately 2 V decreased from the levelizer signal when DTC detected, is output.</li> </ul>	Blinks 1 second each.	Erase DTC or Ignition switch OFF → ON
B2504: SWIVEL ACTUATOR [LH]	<ul style="list-style-type: none"> <li>• Left swivel motors stop at the position when DTC is detected.</li> <li>• The signal, approximately 2 V decreased from the levelizer signal when DTC detected, is output.</li> </ul>	Blinks 1 second each.	Erase DTC or Ignition switch OFF → ON
B2513: HI SEN UNUSUAL [FR]	<ul style="list-style-type: none"> <li>• Right and left headlamp aiming motors stop at the position when DTC is detected.</li> </ul>	—	Erase DTC or Ignition switch OFF → ON
B2514: HI SEN UNUSUAL [RR]	<ul style="list-style-type: none"> <li>• Right and left headlamp aiming motors stop at the position when DTC is detected.</li> </ul>	—	Erase DTC or Ignition switch OFF → ON
C0126: ST ANG SEN SIG	<ul style="list-style-type: none"> <li>• Right and left swivel motor swivel angle returns to 0° and fixed.</li> </ul>	Blinks 1 second each.	Erase DTC or Ignition switch OFF → ON
B2516: SHIFT SIG [P, R]	<ul style="list-style-type: none"> <li>• Right and left swivel motor swivel angle returns to 0° and fixed.</li> </ul>	Blinks 1 second each.	Erase DTC or Ignition switch OFF → ON
B2517: VEHICLE SPEED SIG	<ul style="list-style-type: none"> <li>• Right and left swivel motor swivel angle returns to 0° and fixed.</li> <li>• Right and left headlamp aiming motors stop at the position when DTC is detected.</li> </ul>	Blinks 1 second each.	Erase DTC or Ignition switch OFF → ON
B2519: LEVELIZER CALIB	<ul style="list-style-type: none"> <li>• Right and left headlamp aiming motors stop at the position when DTC is detected.</li> </ul>	—	When the levelizer adjustment is completed.
C0428: ST ANGLE SEN CALIB	<ul style="list-style-type: none"> <li>• Right and left swivel motor swivel angle returns to 0° and fixed.</li> </ul>	Blinks 1 second each.	When the steering angle sensor neutral position registration is completed.
B2521: ECU CIRC	<ul style="list-style-type: none"> <li>• Right and left swivel motors stop at the position when DTC is detected.</li> <li>• Right and left headlamp aiming motors stop at the position when DTC is detected.</li> </ul>	Blinks 1 second each.	Erase DTC or Ignition switch OFF → ON

# AFS CONTROL UNIT

< ECU DIAGNOSIS INFORMATION >

[XENON TYPE]

## DTC Inspection Priority Chart

INFOID:000000009010248

If some DTCs are displayed at the same time, perform inspections one by one based on the following priority chart.

**NOTE:**

- If DTC U1000 is displayed with other DTC, first perform the trouble diagnosis for DTC U1000.
- If DTC U1010 is displayed with other DTC, first perform the trouble diagnosis for DTC U1010.

Priority	Detected items (DTC)
1	<ul style="list-style-type: none"> <li>• U1000: CAN COMM CIRCUIT</li> <li>• U1010: CONTROL UNIT (CAN)</li> </ul>
2	<ul style="list-style-type: none"> <li>• B2519: LEVELIZER CALIB</li> <li>• B2521: ECU CIRC</li> <li>• C0428: ST ANG SEN CALIB</li> </ul>
3	<ul style="list-style-type: none"> <li>• B2503: SWIVEL ACTUATOR [RH]</li> <li>• B2504: SWIVEL ACTUATOR [LH]</li> <li>• B2513: HI SEN UNUSUAL [FR]</li> <li>• B2514: HI SEN UNUSUAL [RR]</li> <li>• B2516: SHIFT SIG [P, R]</li> <li>• B2517: VEHICLE SPEED SIG</li> <li>• C0126: ST ANG SEN SIG</li> </ul>

## DTC Index

INFOID:000000009010249

x: Applicable

CONSULT display	Fail-safe	AFS OFF indicator lamp	Reference
U1000: CAN COMM CIRCUIT	×	×	<a href="#">EXL-84</a>
U1010: CONTROL UNIT (CAN)	×	×	<a href="#">EXL-85</a>
B2503: SWIVEL ACTUATOR [RH]	×	×	<a href="#">EXL-65</a>
B2504: SWIVEL ACTUATOR [LH]	×	×	<a href="#">EXL-65</a>
B2513: HI SEN UNUSUAL [FR]	×		<a href="#">EXL-70</a>
B2514: HI SEN UNUSUAL [RR]	×		<a href="#">EXL-73</a>
B2516: SHIFT SIG [P, R]	×	×	<a href="#">EXL-76</a>
B2517: VEHICLE SPEED SIG	×	×	<a href="#">EXL-77</a>
B2519: LEVELIZER CALIB	×		<a href="#">EXL-78</a>
B2521: ECU CIRC	×	×	<a href="#">EXL-79</a>
C0126: ST ANG SEN SIG	×	×	<a href="#">EXL-82</a>
C0428: ST ANGLE SEN CALIB	×	×	<a href="#">EXL-83</a>

EXL

# EXTERIOR LIGHTING SYSTEM

[XENON TYPE]

< WIRING DIAGRAM >

## WIRING DIAGRAM

### EXTERIOR LIGHTING SYSTEM

#### Wiring Diagram

INFOID:000000009010250

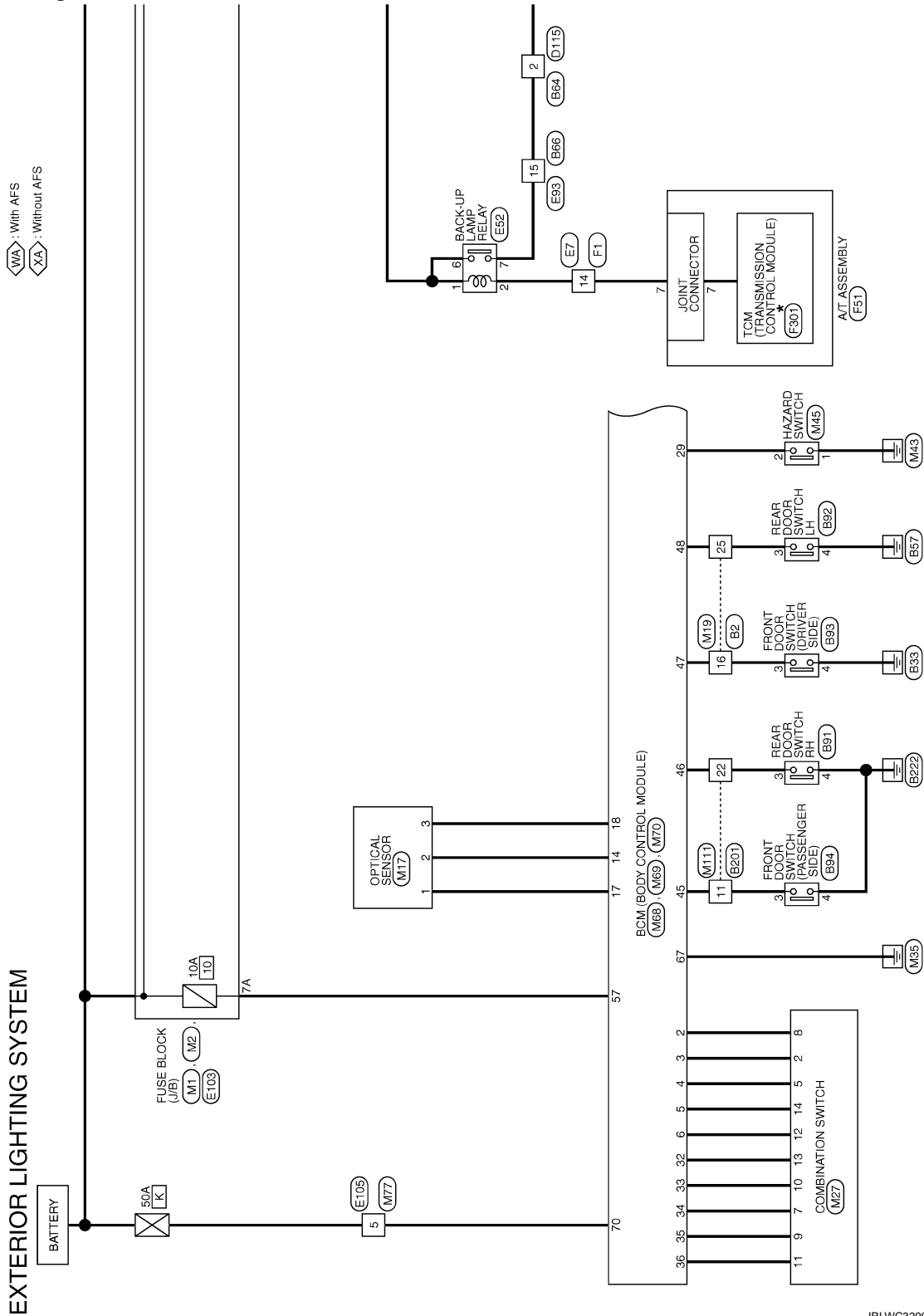

\*: This connector is not shown in "Harness Layout".

2013/01/30

JRLWC3299GB



# EXTERIOR LIGHTING SYSTEM

[XENON TYPE]

< WIRING DIAGRAM >

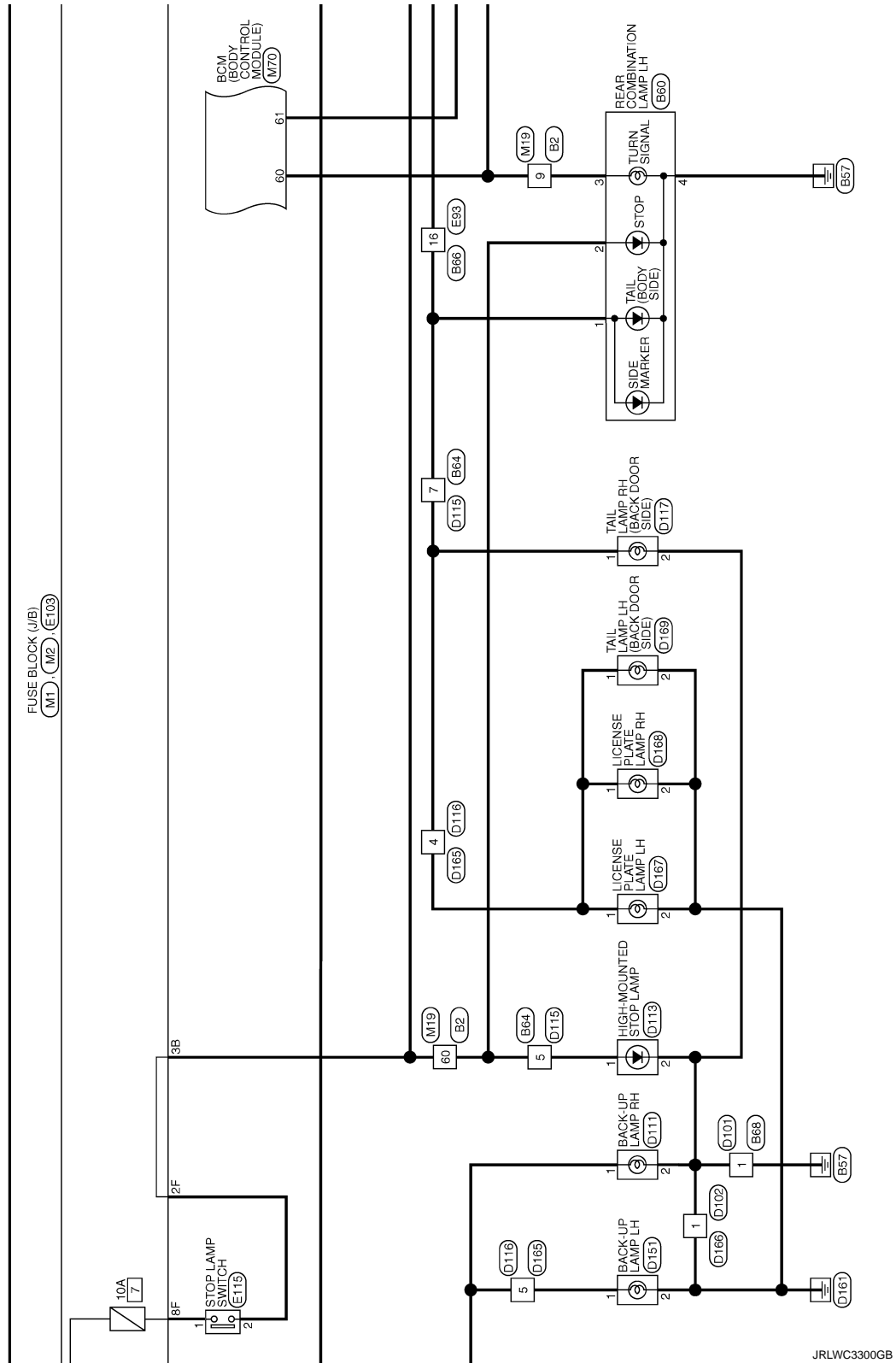

A  
B  
C  
D  
E  
F  
G  
H  
I  
J  
K  
EXL  
M  
N  
O  
P

# EXTERIOR LIGHTING SYSTEM

< WIRING DIAGRAM >

[XENON TYPE]

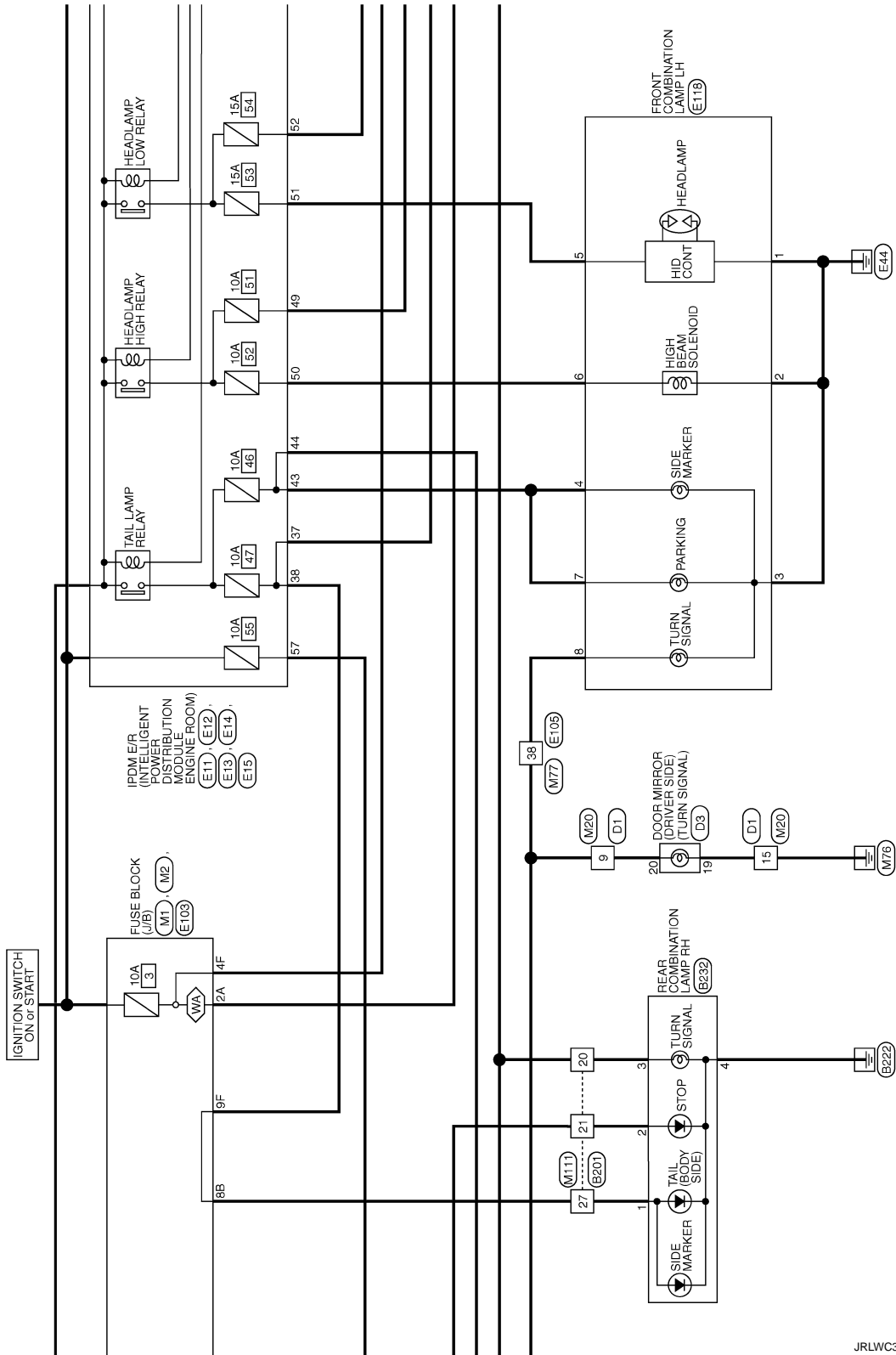

JRLWC3301GB

# EXTERIOR LIGHTING SYSTEM

< WIRING DIAGRAM >

[XENON TYPE]

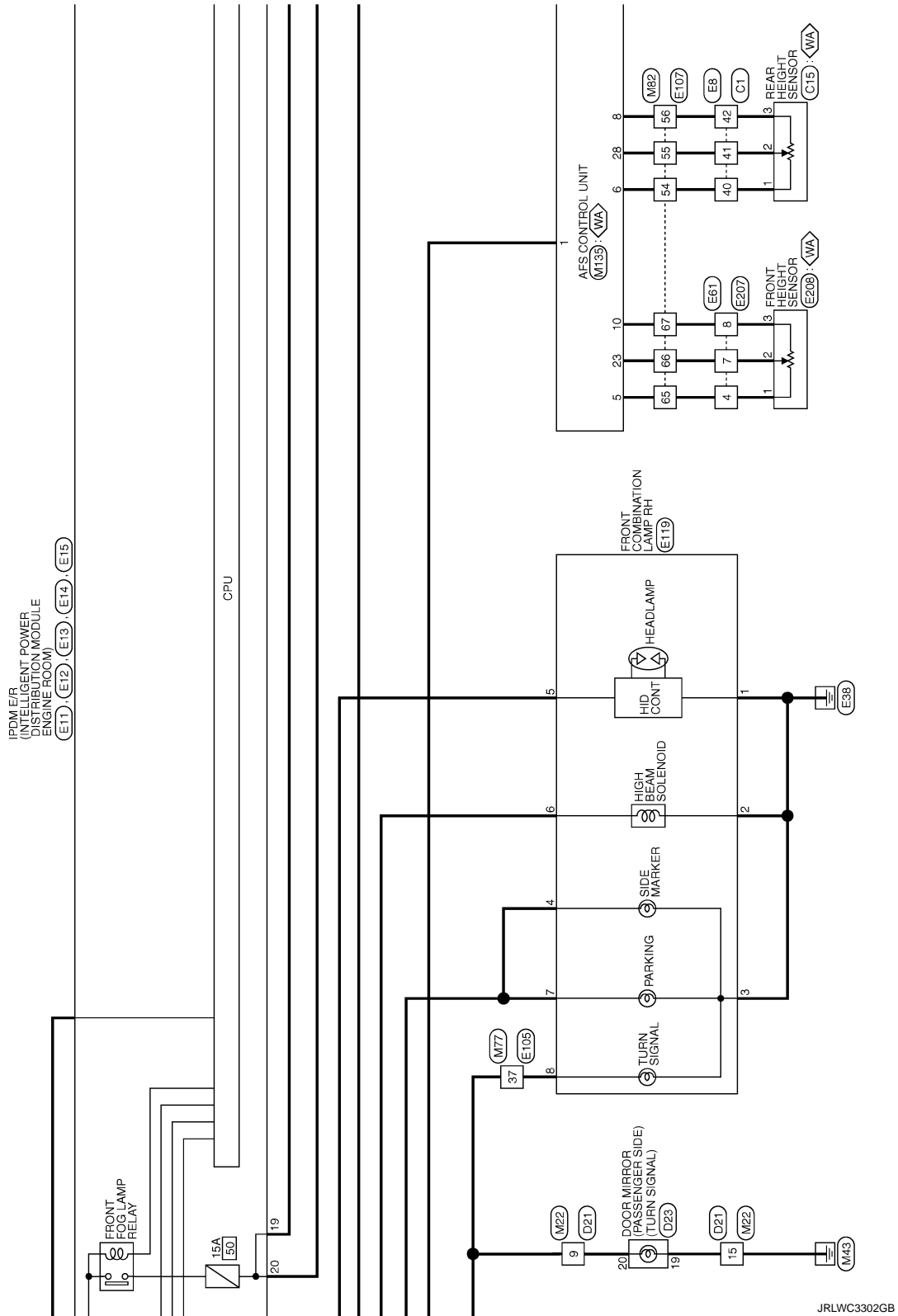

JRLWC3302GB

A  
B  
C  
D  
E  
F  
G  
H  
I  
J  
K  
EXL  
M  
N  
O  
P

# EXTERIOR LIGHTING SYSTEM

< WIRING DIAGRAM >

[XENON TYPE]

IPDM E/F  
(INTELLIGENT POWER  
MODULE)  
ENGINE ROOM  
(E11) (E12) (E13) (E14) (E15)

CPU

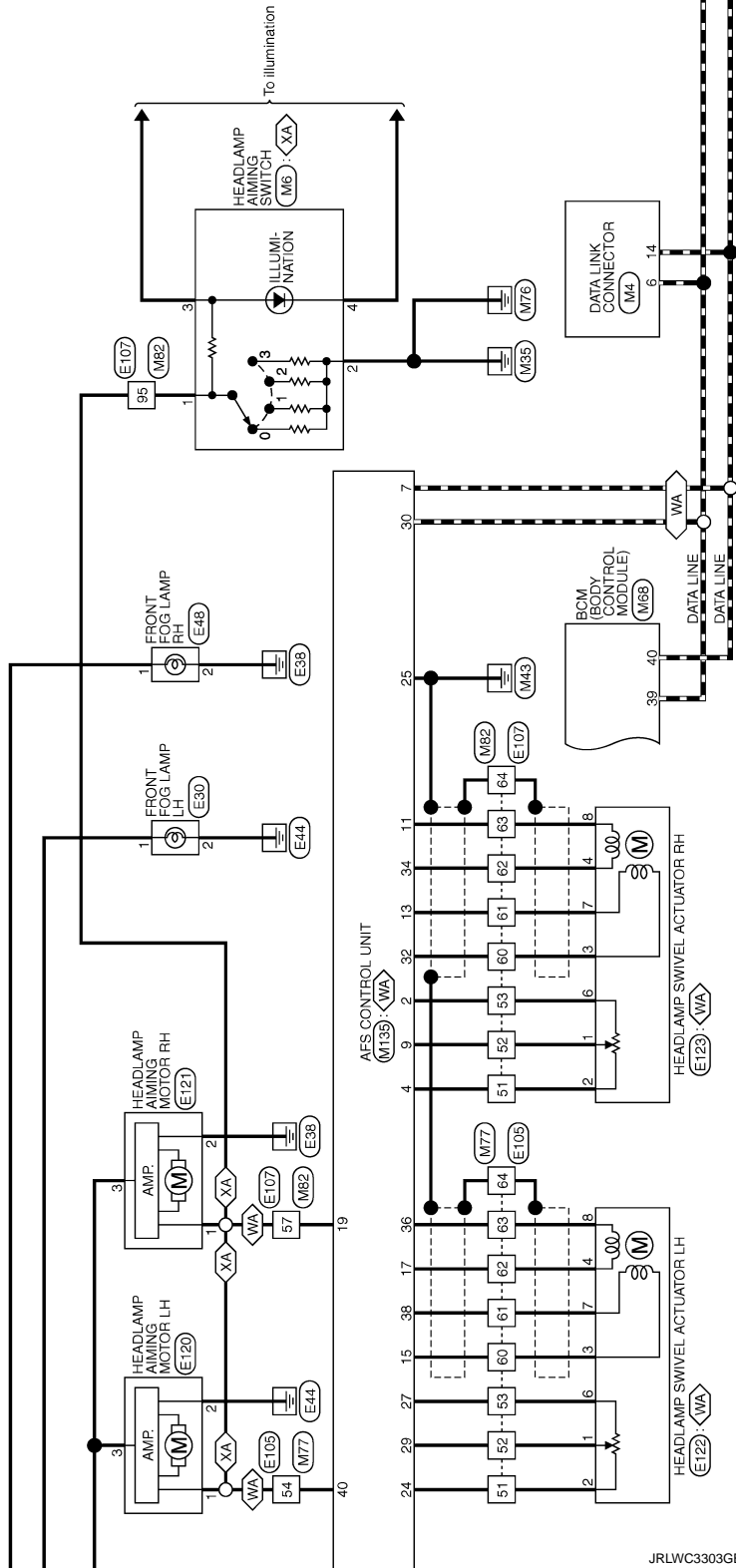

JRLWC3303GB

# EXTERIOR LIGHTING SYSTEM

< WIRING DIAGRAM >

[XENON TYPE]

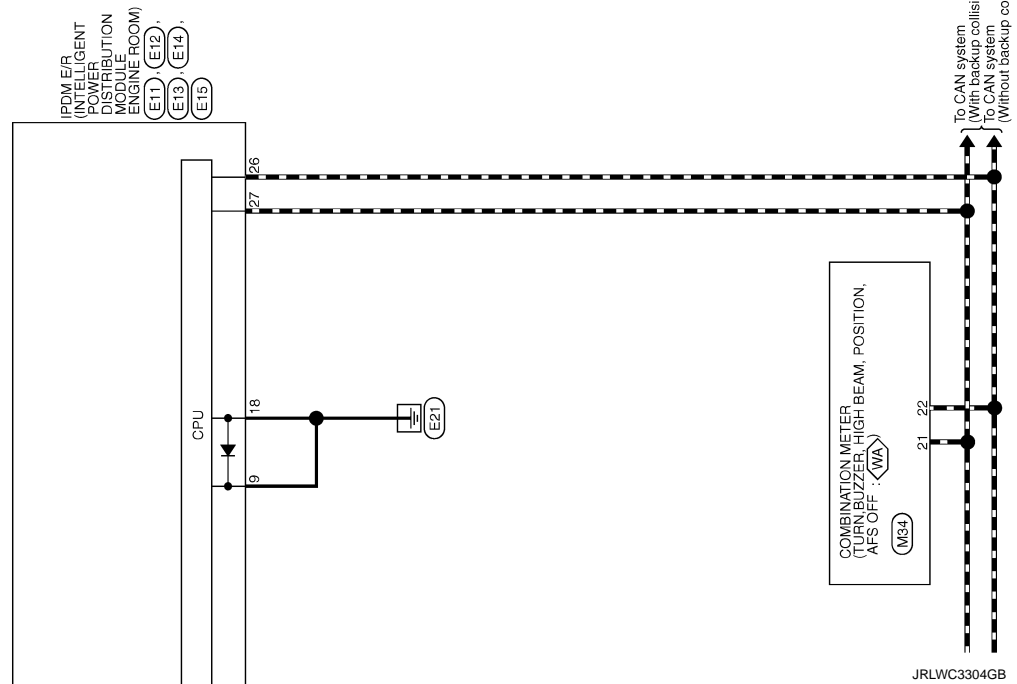

A  
B  
C  
D  
E  
F  
G  
H  
I  
J  
K  
L  
M  
N  
O  
P

EXL

# EXTERIOR LIGHTING SYSTEM

< WIRING DIAGRAM >

[XENON TYPE]

## EXTERIOR LIGHTING SYSTEM

Connector No.	B2
Connector Name	WIRE TO WIRE
Connector Type	TH80MW-CS16-TM4



Terminal No.	Color Of Wire	Signal Name [Specification]
2	L	-
3	BR	-
5	RY	-
6	RY	-
7	V	-
9	G	-
11	WB	-
12	BR	-
13	GR	-
14	BY	-
15	WR	-
16	GR	-
18	GW	-
19	V	-
20	WG	-
21	BW	-
22	V	-
24	G	-
25	O	-
26	Y	-
27	L/O	-
28	Y/R	-
29	L	-
30	R	-
31	G/Y	-
32	B/SB	-
33	LG/R	-
34	BR/W	-
35	GR/R	-
36	SB	-
37	LG	-
38	L	-
39	P	-
40	WG	-
41	O	-

42	GR	-
43	V/W	-
44	LG/B	-
45	RY	-
46	B	-
47	BR	-
49	GR	-
50	R/B	-
51	W/R	-
52	BRY	-
53	O/B	-
54	G/O	-
55	R/B	-
56	LG/R	-
57	GR/R	-
58	Y/G	-
59	V/W	-
60	R	-
63	B	-
64	R	-
65	W	-
66	G	-
67	SHIELD	-
69	LG/B	-
70	P/L	-
71	L	-
72	R	-
77	Y/B	-
78	Y/L	-
79	Y	-
80	W/R	-
81	Y/L	-
84	L/O	-
86	O	-
87	W/R	-
88	O	-
89	W/L	-
90	GR/L	-
91	W	-
92	G	-
94	W/R	-
96	L/W	-
97	R	-
98	V	-
99	L/W	-
100	P/B	-

Connector No.	B60
Connector Name	REAR COMBINATION LAMP LH
Connector Type	NS04FM-CS



Terminal No.	Color Of Wire	Signal Name [Specification]
1	L/W	-
2	R	-
3	G	-
4	B	-

Connector No.	B64
Connector Name	WIRE TO WIRE
Connector Type	NS08MW-CS



Terminal No.	Color Of Wire	Signal Name [Specification]
1	L	-
2	RY	-
3	GW	-
4	R	-
5	R	-
7	L/W	-
8	V	-

Connector No.	B66
Connector Name	WIRE TO WIRE
Connector Type	TH16MW-NH



Terminal No.	Color Of Wire	Signal Name [Specification]
1	R	-
2	B	-
3	G	-
4	W	-
5	SHIELD	-
7	GR	-
8	R/W	-
11	R	-
12	V	-
13	P/L	-
15	RY	-
16	L/W	-

Connector No.	B68
Connector Name	WIRE TO WIRE
Connector Type	M02MW-LC



Terminal No.	Color Of Wire	Signal Name [Specification]
1	B	-
2	R	-

JRLWC6472GB

# EXTERIOR LIGHTING SYSTEM

< WIRING DIAGRAM >

[XENON TYPE]

## EXTERIOR LIGHTING SYSTEM

Connector No.	B91
Connector Name	REAR DOOR SWITCH RH
Connector Type	TH04FM-NH



Terminal No.	Color Of Wire	Signal Name [Specification]
3	GR	DOOR_SW_RR
4	B	GND

Connector No.	B92
Connector Name	REAR DOOR SWITCH LH
Connector Type	TH04FM-NH



Terminal No.	Color Of Wire	Signal Name [Specification]
3	O	DOOR_SW_RL
4	B	GND

Connector No.	B93
Connector Name	FRONT DOOR SWITCH (DRIVER SIDE)
Connector Type	TH04FM-NH



Terminal No.	Color Of Wire	Signal Name [Specification]
3	GR/R	DOOR_SW_DR
4	B	GND

Connector No.	B94
Connector Name	FRONT DOOR SWITCH (PASSENGER SIDE)
Connector Type	TH04FM-NH



Terminal No.	Color Of Wire	Signal Name [Specification]
3	W	DOOR_SW_AS
4	B	GND

Connector No.	B201
Connector Name	WIRE TO WIRE
Connector Type	TH00MW-GS16-TM4

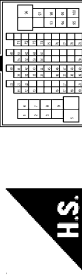

Terminal No.	Color Of Wire	Signal Name [Specification]
1	R/B	-
2	G	-
3	W	-
4	W/B	-
5	W	-
6	Y	-
7	R	-
8	GR	-
9	GR/R	-
11	W	-
12	V	-
13	Y	-
16	L/O	-
17	GR/L	-
18	R/G	-
19	L/Y	-
20	G/Y	-
21	R	-
22	GR	-
27	L/W	-
29	W	-
30	R/L	-
31	Y/L	-
32	W/R	-
33	W/G	-
34	L/R	-
36	G	-
37	V	-
38	SHIELD	-
39	P/B	-
40	W/R	-
41	R	-
42	L	-
43	B/W	-
44	L	-
45	P	-
46	SHIELD	-

47	R	-
48	W	-
49	SHIELD	-
50	V	-
51	L/B	-
52	L/R	-
53	S/B	-
54	V/W	-
59	L	-
60	GR	-
61	P/L	-
62	B/SB	-
63	R/Y	-
64	BR	-
70	O	-
71	W	-
72	SHIELD	-
73	B	-
74	R	-
75	S	-
76	Y	-
77	S/B	-
78	LG	-
79	R/B	-
90	W/B	-
93	Y	-
94	L	-
95	L/R	-
96	R	-
97	W	-
98	V	-
99	L/W	-
100	W	-

Connector No.	B232
Connector Name	REAR COMBINATION LAMP RH
Connector Type	NS04FW-GS



A  
B  
C  
D  
E  
F  
G  
H  
I  
J  
K  
EXL  
M  
N  
O  
P

# EXTERIOR LIGHTING SYSTEM

< WIRING DIAGRAM >

[XENON TYPE]

## EXTERIOR LIGHTING SYSTEM

Terminal No.	Color Of Wire	Signal Name [Specification]
1	L/W	-
2	R	-
3	GY	-
4	B	-

Connector No.	C1
Connector Name	WIRE TO WIRE
Connector Type	SAA36FB-RS10-SJZZ

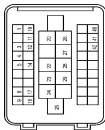

Terminal No.	Color Of Wire	Signal Name [Specification]
1	Y	-
3	SB	-
4	L/Y	-
5	R	-
8	V	-
9	P	-
10	BRY	-
11	Y/V	-
12	V/W	-
14	Y/L	-
17	BR	-
18	R/O	-
20	GW	-
22	L/W	-
23	B	-
24	Y/G	-
25	R	-
26	SB	-
27	R/G	-
28	V	-
29	B	-
40	LG/R	-
41	R/G	-
42	B/R	-

Connector No.	C15
Connector Name	REAR HEIGHT SENSOR
Connector Type	AZZ06FB1



Terminal No.	Color Of Wire	Signal Name [Specification]
1	LG/R	HSG-R
2	R/G	HSG-R
3	B/R	HSG-R

Connector No.	D1
Connector Name	WIRE TO WIRE
Connector Type	TH40FW-CS15

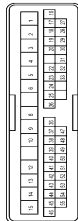

Terminal No.	Color Of Wire	Signal Name [Specification]
1	V	-
2	W	-
3	V	-
4	Y	-
5	LG/R	-
6	BR/W	-
8	V	-
9	G	-
10	L	-
12	B/Y	-
13	Y	-
14	R	-
15	B	-
16	GR/R	-
17	R/W	-
18	B	-
19	R	-

Terminal No.	Color Of Wire	Signal Name [Specification]
20	P	-
22	V	-
23	P/B	-
24	L/O	-
25	BR/W	-
26	W/R	-
27	V	-
28	W/G	-
29	Y/G	-
30	O/L	-
31	GR/B	-
32	BR	-
33	V/W	-
36	G/O	-
37	BRY	-
38	SB	-
39	W/L	-
40	L/W	-
41	Y/G	-
42	P/L	-
43	LG	-
44	GR/L	-
45	SHIELD	-
46	W	-
47	LG	-
48	GW	-
49	Y	-
50	L/Y	-
51	GR/R	-
52	LG/B	-
53	G	-
54	B	-
55	R	-

Connector No.	D3
Connector Name	DOOR MIRROR (DRIVER SIDE)
Connector Type	TH24MW-NH



Terminal No.	Color Of Wire	Signal Name [Specification]
2	BR/W	-
3	W	SIDE CAMERA LH OMM
5	G	-
6	R	SIDE CAMERA LH POWER SUPPLY
7	L	-
8	O	-
9	W/B	-
10	SB	-
11	BR/Y	-
12	L/W	-
14	P	-
15	B/Y	-
16	GR/L	-
17	SHIELD	-
18	B	SIDE CAMERA LH GND
19	B	-
20	G	-
21	L/Y	-
22	GW	-
23	W/L	-
24	Y	-

Connector No.	D21
Connector Name	WIRE TO WIRE
Connector Type	TH40FW-CS15

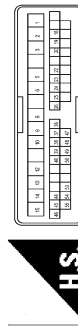

Terminal No.	Color Of Wire	Signal Name [Specification]
1	G	-
2	W	-
3	V	-
5	P/L	-
6	L/R	-
8	L/W	-
9	GY	-
10	L	-
12	B/Y	-
13	L	-
14	R	-



# EXTERIOR LIGHTING SYSTEM

< WIRING DIAGRAM >

[XENON TYPE]

## EXTERIOR LIGHTING SYSTEM

15	B	-	-	-
18	B/W	-	-	-
19	R	-	-	-
20	P	-	-	-
22	Y/R	-	-	-
23	LG/B	-	-	-
24	L/O	-	-	-
25	R/O	-	-	-
26	W/R	-	-	-
36	G/O	-	-	-
37	Y/B	-	-	-
38	V	-	-	-
39	W/L	-	-	-
40	L/O	-	-	-
44	GR/L	-	-	-
45	G	-	-	-
46	W	-	-	-
47	LG	-	-	-
48	L/R	-	-	-
49	Y	-	-	-
50	R/B	-	-	-
53	SHIELD	-	-	-
54	B	-	-	-
55	R	-	-	-

Connector No.	D23
Connector Name	DOOR MIRROR (PASSENGER SIDE)
Connector Type	TH24MV-VH

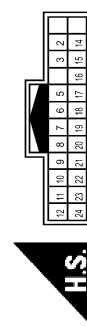

Terminal No.	Color Of Wire	Signal Name [Specification]
2	R/W	-
3	W	SIDE CAMERA LH COMM
5	G	-
6	R	-
7	L	-
8	LG	-
9	G/O	-
10	Y	-
11	Y/B	-
12	L/O	-

14	P	-	-	-
15	B/Y	-	-	-
16	GR/L	-	-	-
17	SHIELD	-	-	-
18	B	-	-	-
19	B	-	-	-
20	G/Y	-	-	-
21	R/B	-	-	-
22	L/R	-	-	-
23	W/L	-	-	-
24	Y	-	-	-

Connector No.	D101
Connector Name	WIRE TO WIRE
Connector Type	M02FW-LC



Terminal No.	Color Of Wire	Signal Name [Specification]
1	B	-
2	L	-

Connector No.	D102
Connector Name	WIRE TO WIRE
Connector Type	M01FBR-S-LC



Terminal No.	Color Of Wire	Signal Name [Specification]
1	B	-

Connector No.	D111
Connector Name	BACK-UP LAMP RH
Connector Type	RS02FGY



Terminal No.	Color Of Wire	Signal Name [Specification]
1	R/Y	-
2	B	-

Connector No.	D113
Connector Name	HIGH-MOUNTED STOP LAMP
Connector Type	TK02MBR-P



Terminal No.	Color Of Wire	Signal Name [Specification]
1	R	-
2	B	-

Connector No.	D115
Connector Name	WIRE TO WIRE
Connector Type	NS08FW-LCS



Terminal No.	Color Of Wire	Signal Name [Specification]
1	L	-
2	R/Y	-
3	G/W	-
4	R	-
5	R	-
7	L/W	-
8	V	-

Connector No.	D116
Connector Name	WIRE TO WIRE
Connector Type	NS08FW-LCS

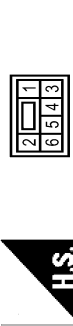

Terminal No.	Color Of Wire	Signal Name [Specification]
1	V	-
2	R	-
3	G/W	-
4	L/W	-
5	R/Y	-
6	L	-

A  
B  
C  
D  
E  
F  
G  
H  
I  
J  
K  
L  
M  
N  
O  
P

EXL

# EXTERIOR LIGHTING SYSTEM

< WIRING DIAGRAM >

[XENON TYPE]

## EXTERIOR LIGHTING SYSTEM

Connector No.	D117
Connector Name	TAIL LAMP RH (BACK DOOR SIDE)
Connector Type	T02FB



Terminal No.	Color Of Wire	Signal Name [Specification]
1	L/W	-
2	B	-

Connector No.	D151
Connector Name	BACK-UP LAMP LH
Connector Type	RS02FGY



Terminal No.	Color Of Wire	Signal Name [Specification]
1	R/Y	-
2	B	-

Connector No.	D167
Connector Name	LICENSE PLATE LAMP LH
Connector Type	TK02FBR



Terminal No.	Color Of Wire	Signal Name [Specification]
1	L	-
2	B	-

Connector No.	D168
Connector Name	LICENSE PLATE LAMP RH
Connector Type	TK02FBR



Terminal No.	Color Of Wire	Signal Name [Specification]
1	L/W	-
2	B	-

Connector No.	D165
Connector Name	WIRE TO WIRE
Connector Type	NS06MW-CS



Terminal No.	Color Of Wire	Signal Name [Specification]
1	V	-
2	R	-
3	G/W	-
4	L/W	-
5	R/Y	-
6	L	-

Connector No.	D166
Connector Name	WIRE TO WIRE
Connector Type	M01MBR-PSLC



Terminal No.	Color Of Wire	Signal Name [Specification]
1	B	-

Connector No.	D169
Connector Name	TAIL LAMP LH (BACK DOOR SIDE)
Connector Type	T02FB



Terminal No.	Color Of Wire	Signal Name [Specification]
1	L	-
2	B	-

Connector No.	E7
Connector Name	WIRE TO WIRE
Connector Type	TH02MW-NH



Terminal No.	Color Of Wire	Signal Name [Specification]
1	W	-
2	G	-
3	L/O	-
4	LG	-
5	W/L	-
6	G/O	-
7	L/R	-
8	LG/R	-
14	R	-
16	SB	-
17	R/W	-
18	Y/G	-
19	BR/Y	-
20	PI/B	-
21	RI/B	-
22	Y	-
23	BR	-
24	PL	-

# EXTERIOR LIGHTING SYSTEM

< WIRING DIAGRAM >

[XENON TYPE]

## EXTERIOR LIGHTING SYSTEM

29	P	-
30	BR	-
31	L	-
32	P	-

Connector No.	E8
Connector Name	WIRE TO WIRE
Connector Type	SAA338MB-RS10-SJZZ

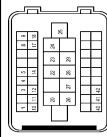

Terminal No.	Color Of Wire	Signal Name [Specification]
1	Y	-
3	SB	-
4	LY	-
5	R	-
8	V	-
9	P	-
10	BR/Y	-
11	Y/V	-
12	V/W	-
14	Y/L	-
17	BR	-
18	R/O	-
20	G/W	-
22	L/W	-
23	B	-
24	Y/G	-
25	R	-
26	SB	-
27	R/G	-
28	V	-
29	B	-
40	LG/R	-
41	R/G	-
42	BR	-

Connector No.	E11
Connector Name	IPDM ER INTELLIGENT POWER DISTRIBUTION MODULE (ENGINE ROOM)
Connector Type	M06FELC



Terminal No.	Color Of Wire	Signal Name [Specification]
9	B	-
14	L	-

Connector No.	E12
Connector Name	IPDM ER INTELLIGENT POWER DISTRIBUTION MODULE (ENGINE ROOM)
Connector Type	NS08FBRCS

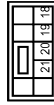

Terminal No.	Color Of Wire	Signal Name [Specification]
18	B	-
19	V	-
20	W	-
21	L	-

Connector No.	E13
Connector Name	IPDM ER INTELLIGENT POWER DISTRIBUTION MODULE (ENGINE ROOM)
Connector Type	TH12FM-NH



Terminal No.	Color Of Wire	Signal Name [Specification]
23	GR/R	-
24	WG	-
25	LY	-
26	P	-
27	I	-
30	R/W	-
32	LG	-
33	R	-
34	G	-

Connector No.	E14
Connector Name	IPDM ER INTELLIGENT POWER DISTRIBUTION MODULE (ENGINE ROOM)
Connector Type	NS12FBRCS



Terminal No.	Color Of Wire	Signal Name [Specification]
35	W	-
36	V	-
37	L	-
38	Y	-
39	L/B	-
41	L/G	-
42	L	-
43	L/G	-
44	L/W	-
45	Y/R	-

Connector No.	E15
Connector Name	IPDM ER INTELLIGENT POWER DISTRIBUTION MODULE (ENGINE ROOM)
Connector Type	NS16FM-CS

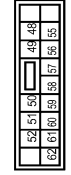

Terminal No.	Color Of Wire	Signal Name [Specification]
48	BR	-
49	R	-
50	LG/B	-
51	BR/Y	-
52	W	-
55	O	-
56	L	-
57	V	-
58	BR/R	-
59	W/B	-
60	V/R	-
61	W	-
62	SB	-

Connector No.	E30
Connector Name	FRONT FOG LAMP LH
Connector Type	FH20ZFB



Terminal No.	Color Of Wire	Signal Name [Specification]
1	W	-
2	B	-

A  
B  
C  
D  
E  
F  
G  
H  
I  
J  
K  
EXL  
M  
N  
O  
P

# EXTERIOR LIGHTING SYSTEM

< WIRING DIAGRAM >

[XENON TYPE]

## EXTERIOR LIGHTING SYSTEM

Connector No.	E48
Connector Name	FRONT FOG LAMP RH
Connector Type	FH202FB



Terminal Color Of No.	Wire	Signal Name [Specification]
1	V	-
2	B	-

Connector No.	E52
Connector Name	BACK-UP LAMP RELAY
Connector Type	M06FER-LC



Terminal Color Of No.	Wire	Signal Name [Specification]
1	V	-
2	R	-
3	W/B	-
5	Y/L	-
6	V	-
7	R/Y	-

Connector No.	E61
Connector Name	WIRE TO WIRE
Connector Type	RH8MB



Terminal Color Of No.	Wire	Signal Name [Specification]
1	W	-
2	R	-
3	L/B	-
4	L/Y	-
5	W/G	-
7	V	-
8	B/W	-

Connector No.	E93
Connector Name	WIRE TO WIRE
Connector Type	TH16FW-NH



Terminal Color Of No.	Wire	Signal Name [Specification]
1	R	-
2	B	-
3	G	-
4	W	-
5	SHIELD	-
7	GR	-
8	R/W	-
11	R	-
12	V	-
13	P/L	-
15	R/Y	-
16	L/W	-

Connector No.	E103
Connector Name	FUSE BLOCK (J/B)
Connector Type	NS16FM-CS

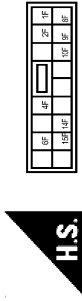

Terminal Color Of No.	Wire	Signal Name [Specification]
10F	G	-
14F	Y	-
15F	G	-
1F	W/B	-
2F	R	-
4F	G	-
6F	Y/G	-
8F	L/B	-
9F	Y	-

Connector No.	E105
Connector Name	WIRE TO WIRE
Connector Type	TH80MW-CS16-TM4



Terminal Color Of No.	Wire	Signal Name [Specification]
1	L	-
2	L/W	-
3	R/B	-
4	L	-
5	Y	-
7	W/G	-
8	P/B	-
9	W/B	-
10	G	-
11	L	-
12	P	-

13	P/B	-
14	BR	-
15	L/B	-
16	SB	-
18	BR	-
19	Y/G	-
20	BR/Y	-
21	Y/V	-
22	L	-
23	Y	-
24	L/W	-
28	O	-
29	R/W	-
30	L/B	-
31	Y	-
32	GR/L	-
34	Y	-
35	R	-
36	B/R	-
37	G/Y	-
38	G	-
40	SB	-
41	W/R	-
42	R	-
43	V	-
51	L/O	-
52	BR/W	-
53	BR/Y	-
54	GR/L	-
60	W	-
61	B	-
62	R	-
63	G	-
64	SHIELD	-
91	BR	-
92	L/W	-
94	Y/B	-
95	G/R	-
97	R	-
98	G/B	-
100	W/R	-

# EXTERIOR LIGHTING SYSTEM

< WIRING DIAGRAM >

[XENON TYPE]

## EXTERIOR LIGHTING SYSTEM

Connector No.	E107
Connector Name	WIRE TO WIRE
Connector Type	TH80MW-CS16-TM4

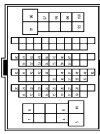

Terminal No.	Color Of Wire	Signal Name [Specification]
1	L	-
4	V/W	-
5	GR	-
6	GR	-
9	GR/L	-
10	Y/R	-
11	L/R	-
12	W/G	-
13	BR/Y	-
14	LG	-
15	BR/W	-
16	BY	-
17	WB	-
18	GR/R	-
20	W/R	-
21	B	-
22	R/L	-
23	G/R	-
24	R/W	-
25	W/L	-
26	R	-
27	L	-
28	G/B	-
35	G	-
36	Y	-
37	R	-
38	GY	-
39	O	-
40	W	-
41	R	-
42	B	-
43	G	-
44	SHIELD	-
46	B	-
47	W	-
48	SHIELD	-

49	W	-
50	SHIELD	-
51	Y/R	-
52	GR	-
53	LG/B	-
54	LG/R	-
55	R/G	-
56	B/R	-
57	SB	-
60	G	-
61	B	-
62	W	-
63	R	-
64	SHIELD	-
65	L/Y	-
66	V	-
67	BR/W	-
91	GR	-
85	SB	-
96	GR	-
97	GR/L	-
98	GW	-
99	RY	-
100	L	-

Connector No.	E115
Connector Name	STOP LAMP SWITCH
Connector Type	M04FW-LC



Terminal No.	Color Of Wire	Signal Name [Specification]
1	L/B	-
2	R	-
3	G	-
4	L/R	-

Connector No.	E118
Connector Name	FRONT COMBINATION LAMP LH
Connector Type	RS08FB-FR



Terminal No.	Color Of Wire	Signal Name [Specification]
1	B	-
2	B	-
3	B	-
4	L	-
5	BR/Y	-
6	LG/B	-
7	LG	-
8	G	-

Connector No.	E119
Connector Name	FRONT COMBINATION LAMP RH
Connector Type	RS08FB-FR



Terminal No.	Color Of Wire	Signal Name [Specification]
1	B	-
2	B	-
3	B	-
4	L	-
5	W	-
6	R	-
7	L	-
8	GY	-

Connector No.	E120
Connector Name	HEADLAMP AIMING MOTOR LH
Connector Type	HS03FGY



Terminal No.	Color Of Wire	Signal Name [Specification]
1	GR/L	- [For Mexico]
2	SB	- [Except for Mexico]
3	G	-

Connector No.	E121
Connector Name	HEADLAMP AIMING MOTOR RH
Connector Type	HS03FGY



Terminal No.	Color Of Wire	Signal Name [Specification]
1	SB	-
2	B	-
3	G	-

A  
B  
C  
D  
E  
F  
G  
H  
I  
J  
K  
EXL  
M  
N  
O  
P

# EXTERIOR LIGHTING SYSTEM

< WIRING DIAGRAM >

[XENON TYPE]

## EXTERIOR LIGHTING SYSTEM

Connector No.	E122
Connector Name	HEADLAMP SWIVEL ACTUATOR LH
Connector Type	RS08FGY-PR



Terminal No.	Color Of Wire	Signal Name [Specification]
1	BRW	-
2	L/O	-
3	W	-
4	R	-
5	BSV	-
7	B	-
8	G	-

Connector No.	E123
Connector Name	HEADLAMP SWIVEL ACTUATOR RH
Connector Type	RS08FGY-PR



Terminal No.	Color Of Wire	Signal Name [Specification]
1	GR	-
2	Y/R	-
3	G	-
4	W	-
6	LG/B	-
7	B	-
8	R	-

Connector No.	E207
Connector Name	WIRE TO WIRE
Connector Type	RH08FB



Terminal No.	Color Of Wire	Signal Name [Specification]
1	W	-
2	R	-
3	L/B	-
4	L/Y	-
5	W/G	-
7	V	-
8	B/W	-

Connector No.	E208
Connector Name	FRONT HEIGHT SENSOR
Connector Type	RH08FB



Terminal No.	Color Of Wire	Signal Name [Specification]
1	L/Y	HSV-F
2	V	HS-F
3	B/W	HSC-F

Connector No.	F1
Connector Name	WIRE TO WIRE
Connector Type	TH02FM-NH

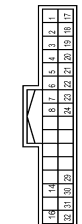

Terminal No.	Color Of Wire	Signal Name [Specification]
1	W	-
2	G	-
3	L/O	-
4	LG	-
5	W/L	-
6	G/O	-
7	L/R	-
8	L/R	-
14	R	-
16	SB	-
17	R/W	-
18	Y/G	-
19	B/Y	-
20	P/B	-
21	R/B	-
22	Y	-
23	BRW	-
24	P/L	-
29	P	-
30	BR	-
31	L	-
32	P	-

Connector No.	F51
Connector Name	A/T ASSEMBLY
Connector Type	RK10FG

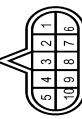

Terminal No.	Color Of Wire	Signal Name [Specification]
1	V	IGNITION POWER SUPPLY
2	P	BATTERY POWER SUPPLY
3	L	CANH
4	SB	KLINE
5	B	GROUND
6	V	IGNITION POWER SUPPLY
7	R	BACK-UP LAMP RELAY
8	P	CANL
9	BR	STARTER RELAY
10	B	GROUND

Connector No.	F301
Connector Name	TCM (TRANSMISSION CONTROL MODULE)
Connector Type	SP10FG

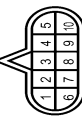

Terminal No.	Color Of Wire	Signal Name [Specification]
1	-	IGNITION POWER SUPPLY
2	-	BATTERY POWER SUPPLY
3	-	CANH
4	-	KLINE
5	-	GROUND
6	-	IGNITION POWER SUPPLY
7	-	BACK-UP LAMP RELAY
8	-	CANL
9	-	STARTER RELAY
10	-	GROUND

# EXTERIOR LIGHTING SYSTEM

< WIRING DIAGRAM >

[XENON TYPE]

## EXTERIOR LIGHTING SYSTEM

Connector No.	M1
Connector Name	FUSE BLOCK (J/B)
Connector Type	NS08FW-M2

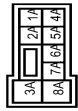

Terminal No.	Color Of Wire	Signal Name [Specification]
1A	Y	-
2A	GR	-
3A	W	-
4A	YG	-
5A	V	-
6A	LW	-
7A	LG	-
8A	W	-

Connector No.	M2
Connector Name	FUSE BLOCK (J/B)
Connector Type	NS10FW-CS

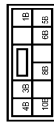

Terminal No.	Color Of Wire	Signal Name [Specification]
1B	R	-
3B	R	-
4B	B	-
5B	BR	-
6B	Y	-
8B	L/O	-
10B	W/B	-

Connector No.	M4
Connector Name	DATA LINK CONNECTOR
Connector Type	BD16FW

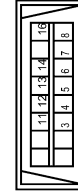

Terminal No.	Color Of Wire	Signal Name [Specification]
3	LG	-
4	B	-
5	B	-
6	L	-
7	SB	-
8	GR	-
11	SB	-
12	R	-
13	L	-
14	P	-
16	Y	-

Connector No.	M6
Connector Name	HEADLAMP AIMING SWITCH
Connector Type	A04FW



Terminal No.	Color Of Wire	Signal Name [Specification]
1	SB	-
2	B	-
3	L/O	-
4	B	-

Connector No.	M17
Connector Name	OPTICAL SENSOR
Connector Type	TK03FW



Terminal No.	Color Of Wire	Signal Name [Specification]
1	Y/G	POWER
2	P/B	OUTPUT
3	B/Y	GND

Connector No.	M19
Connector Name	WIRE TO WIRE
Connector Type	TH80FW-CS16-TM4



Terminal No.	Color Of Wire	Signal Name [Specification]
2	L	-
3	BR	-
5	R/W	-
6	L	-
7	V	-
9	G	-
11	W/B	-
12	BR	-
13	GR	-
14	R/Y	-
15	W/R	-
16	GR	-
18	GW	-
19	V	-
20	WG	-
21	B/W	-
22	V	-

24	G	-
25	O	-
26	Y	-
27	L/O	-
28	Y/R	-
29	L	-
30	R	-
31	G/Y	-
32	B/SB	-
33	LG/R	-
34	BR/W	-
35	GR/R	-
36	SB	-
37	LG	-
38	L	-
39	P	-
40	W/G	-
41	O	-
42	GR	-
43	V/W	-
44	LG/B	-
45	R/Y	-
46	B	-
47	BR/W	-
49	GR	-
50	R/B	-
51	W/R	-
52	BR/Y	-
53	O/B	-
54	G/O	-
55	R/B	-
56	LG/R	-
57	GR/R	-
58	Y/G	-
59	V/W	-
60	R	-
63	B	-
64	R	-
65	W	-
66	G	-
67	SHIELD	-
69	LG/B	-
70	P/L	-
71	L	-
72	R	-
73	Y/B	-
78	Y/L	-
79	Y	-
80	W/R	-
81	Y/L	-

A  
B  
C  
D  
E  
F  
G  
H  
I  
J  
K  
EXL  
M  
N  
O  
P

# EXTERIOR LIGHTING SYSTEM

< WIRING DIAGRAM >

[XENON TYPE]

## EXTERIOR LIGHTING SYSTEM

84	L/O	-
86	O	-
87	W/R	-
88	O	-
89	W/L	-
90	GR/L	-
91	W	-
92	G	-
94	W/R	-
96	L/W	-
97	R	-
98	V	-
99	L/W	-
100	P/B	-

Connector No.	M20
Connector Name	WIRE TO WIRE
Connector Type	TH40MW-CS15

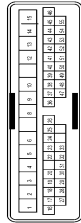

Terminal No.	Color Of Wire	Signal Name [Specification]
1	V	-
2	W	-
3	V	-
4	Y	-
5	LG/R	-
6	BR/W	-
8	V	-
9	G	-
10	L	-
12	B/Y	-
13	Y	-
14	R	-
15	B	-
16	GR/R	-
17	V/W	-
18	B	-
19	P	-
20	V	-
22	V	-
23	P/B	-

24	L/O	-
25	BR/W	-
26	W/R	-
27	V	-
28	W/G	-
29	Y/G	-
30	O/L	-
31	GR/B	-
32	BR	-
33	V/W	-
36	G/O	-
37	BR/Y	-
38	SB	-
39	W/L	-
40	L/W	-
41	Y/G	-
42	P/L	-
43	LG	-
44	GR	-
45	SHIELD	-
46	W	-
47	LG	-
48	GW	-
49	Y	-
50	L/Y	-
51	GR/R	-
52	LG/B	-
53	G	-
54	B	-
55	R	-

Connector No.	M22
Connector Name	WIRE TO WIRE
Connector Type	TH40MW-CS15

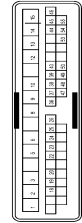

Terminal No.	Color Of Wire	Signal Name [Specification]
1	G	-
2	W	-
3	V	-
5	P/L	-

6	L/R	-
8	L/W	-
9	G/Y	-
10	L	-
12	B/Y	-
13	L	-
14	R	-
15	B	-
18	B/W	-
19	R	-
20	P	-
22	Y/R	-
23	LG/B	-
24	L/W	-
25	W/R	-
26	W/R	-
36	G/O	-
37	G/B	-
38	V/B	-
39	W/L	-
40	L/O	-
44	GR	-
45	G	-
46	W	-
47	LG	-
48	L/R	-
49	Y	-
50	R/B	-
53	SHIELD	-
54	B	-
55	R	-

Connector No.	M27
Connector Name	COMBINATION SWITCH
Connector Type	TH16FM-AH

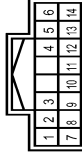

Terminal No.	Color Of Wire	Signal Name [Specification]
1	W/B	-
2	GR	-
3	L/R	-

4	W	IGN
5	L	OUTPUT 3
6	B	GND
7	W	INPUT 3
8	BR/Y	OUTPUT 5
9	RW	INPUT 2
10	Y	INPUT 4
11	SB	INPUT 1
12	V	OUTPUT 1
13	LG	INPUT 5
14	G	OUTPUT 2

Connector No.	M34
Connector Name	COMBINATION METER
Connector Type	TH40FM-NH

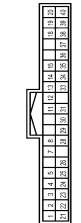

Terminal No.	Color Of Wire	Signal Name [Specification]
1	Y	BATTERY POWER SUPPLY
2	GR	IGNITION SIGNAL
3	B	GROUND
4	B	ILL. GND
5	B	ILL. CONTROL OUTPUT
7	R	TOW MODE SIGNAL
8	P/L	TRIP RESET SWITCH SIGNAL
11	G	ENTER SWITCH SIGNAL
12	O	SELECT SWITCH SIGNAL
13	W/R	ILLUMINATION CONTROL SWITCH SIGNAL (+)
14	R	ILLUMINATION CONTROL SWITCH SIGNAL (-)
15	R/W	AIR BAG SIGNAL
18	W/R	AMBIENT SENSOR SIGNAL
19	V/W	AC AUTO AMP CONNECTION RECOGNITION SIGNAL
20	B	AMBIENT SENSOR GROUND
21	L	CANH
22	P	CANH
23	B	GROUND
24	V	FUEL LEVEL SENSOR GROUND
25	O/L	ALL TERMINATOR SIGNAL
26	W	PARKING BRAKE SWITCH SIGNAL
28	GR	SECURITY SIGNAL
29	BR	WASHER LEVEL SWITCH SIGNAL



# EXTERIOR LIGHTING SYSTEM

< WIRING DIAGRAM >

[XENON TYPE]

## EXTERIOR LIGHTING SYSTEM

30	SB	VEHICLE SPEED SIGNAL (2-PULSE)
31	BR/W	VEHICLE SPEED SIGNAL (6-PULSE)
33	W	SNOW MODE SIGNAL
34	BR/Y	FUEL LEVEL SENSOR SIGNAL
35	O/B	SEAT BELT BUCKLE SWITCH SIGNAL (DRIVER SIDE)
36	G/Y	PASSENGER SEAT BELT WARNING SIGNAL
37	R/Y	NON-MANUAL MODE SIGNAL
38	L/W	MANUAL MODE SHIFT DOWN SIGNAL
39	Y/B	MANUAL MODE SHIFT UP SIGNAL
40	G/W	MANUAL MODE SIGNAL

Connector No.	M45
Connector Name	HAZARD SWITCH
Connector Type	TH04FW



Terminal No.	Color Of Wire	Signal Name [Specification]
1	B	-
2	W	-
3	L/O	-
4	B	-

Connector No.	M68
Connector Name	BCM (BODY CONTROL MODULE)
Connector Type	TH40FB-NH

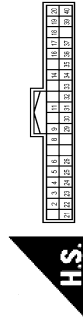

Terminal No.	Color Of Wire	Signal Name [Specification]
2	BR/Y	COMBI SW INPUT 5
3	GR	COMBI SW INPUT 4
4	L	COMBI SW INPUT 3
5	G	COMBI SW INPUT 2

6	V	COMBI SW INPUT 1
8	V	POWER WINDOW SW COMM
9	R	STOP LAMP SW 1
11	R	RAIN SENSOR SERIAL LINK
14	P/B	OPTICAL SENSOR
16	L/O	DIMMER SIGNAL
17	Y/G	SENSOR PWR SPLY
18	BY	RECEIVER/SENSOR GND
19	BR	RECEIVER PWR SPLY
20	G/R	KYLS ENT RECEIVER COMM
21	P	NATS ANT AMP
22	W/B	KYLS ENT RECEIVER RSSI
23	GR/R	SECURITY IND/CONT
24	SB	DONGLE LINK
25	LG/R	NATS ANT AMP
26	O	INTELLIGENT KEY IDENTIFICATION
28	W	HAZARD SW
30	W/L	BK DOOR OPNR SW
31	W/G	DR DOOR UNLK/SENSOR
32	LG	COMBI SW OUTPUT 5
33	Y	COMBI SW OUTPUT 4
34	W	COMBI SW OUTPUT 3
35	R/W	COMBI SW OUTPUT 2
36	SB	COMBI SW OUTPUT 1
37	G/Y	SHIFT P
39	L	CAN/L
40	P	-

Connector No.	M69
Connector Name	BCM (BODY CONTROL MODULE)
Connector Type	FEA09FB-FH4G-SA

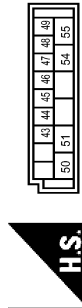

Terminal No.	Color Of Wire	Signal Name [Specification]
43	Y/L	BK DOOR SW
44	G/W	REAR WIPER STOP POSITION
45	W	PASSENGER DOOR SW
46	GR	REAR-RH DOOR SW
47	GR/R	DRIVER DOOR SW
48	O	REAR LH DOOR SW
49	BR/Y	LUGGAGE ROOM LAMP-CONT

50	BY	REMOTE ENGINE START
51	WR	BACK DOOR REQ SW
54	L	REAR WIPER OUTPUT
55	G	REAR DOOR UNLK OUTPUT

Connector No.	M70
Connector Name	BCM (BODY CONTROL MODULE)
Connector Type	FEA09FW-FH4G-SA

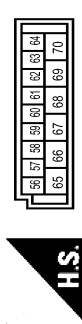

Terminal No.	Color Of Wire	Signal Name [Specification]
56	WR	INT ROOM LAMP PWR SPLY
57	LG	BAT (FUSE)
58	R/W	SHOCK DETECT SENS
59	G	PASSENGER DOOR UNLK OUTPUT
60	G	TURN SIGNAL RH OUTPUT
61	G/Y	TURN SIGNAL LH OUTPUT
62	R	STEP LAMP CONT
63	BR	ROOM LAMP TIMER CONT
64	GR/R	CRANKING REQUEST
65	R	ALL DOOR LOCK OUTPUT
66	V	DR DOOR FUEL LID UNLK OUTPUT
67	B	GND
68	Y	PW PWR SPLY (IGN)
69	W	PW PWR SPLY (BAT)
70	Y	BAT (FIL)

Connector No.	M77
Connector Name	WIRE TO WIRE
Connector Type	TH80FW-CS16-TM4

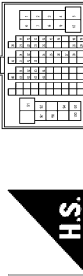

Terminal No.	Color Of Wire	Signal Name [Specification]
1	W	-
2	L/W	-
3	RB	-
4	L	-
5	Y	-
6	SB	-
7	W/G	-
8	P/B	-
9	W/B	-
10	G	-
11	L	-
12	P	-
13	P/B	-
14	BR	-
15	O/L	-
16	SB	-
18	BR	-
19	Y/G	-
20	BR/Y	-
21	V	-
22	L	-
23	Y	-
24	L/W	-
28	O	-
29	R/W	-
30	O/L	-
31	Y	-
32	GR/R	-
34	Y	-
35	R	-
36	B/O	-
37	G/Y	-
38	G	-
40	SB	-
41	W/R	-
42	R	-

A  
B  
C  
D  
E  
F  
G  
H  
I  
J  
K

EXL

M  
N  
O  
P

# EXTERIOR LIGHTING SYSTEM

< WIRING DIAGRAM >

[XENON TYPE]

## EXTERIOR LIGHTING SYSTEM

43	V	-
51	L/O	-
52	BR/W	-
53	BR/Y	-
54	GR/L	-
60	W	-
61	B	-
62	G	-
63	R	-
64	SHIELD	-
91	BR	-
92	L/W	-
94	Y/B	-
95	L/R	-
97	R	-
98	OIL	-
100	W/B	-

Connector No. M82  
 Connector Name WIRE TO WIRE  
 Connector Type TH80FW-CS16-TM4

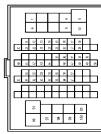

Terminal No.	Color Of Wire	Signal Name [Specification]
1	L	-
4	V/W	-
5	G/R	-
6	P	-
9	GR/L	-
10	Y/R	-
11	L/R	-
12	W/G	-
13	BR/Y	-
14	LG	-
15	BR/W	-
16	BY	-
17	W/B	-
18	GR/R	-
20	W/R	-
21	B	-
22	R/L	-

23	G/R	-
24	R/W	-
25	W/L	-
26	R	-
27	L	-
28	B/SB	-
35	G	-
36	Y	-
37	R	-
38	G/Y	-
39	O	-
40	W	-
41	R	-
42	B	-
43	G	-
44	SHIELD	-
46	B	-
47	W	-
48	SHIELD	-
49	W	-
50	SHIELD	-
51	Y/R	-
52	GR	-
53	LG/B	-
54	LG/R	-
55	RG	-
56	B/O	-
57	SB	-
60	G	-
61	B	-
62	W	-
63	R	-
64	SHIELD	-
65	L/Y	-
66	V	-
67	B/W	-
91	G/R	-
95	SB	-
96	G/R	-
97	GR/L	-
98	G/W	-
99	P	-
100	L	-

Connector No. M111  
 Connector Name WIRE TO WIRE  
 Connector Type TH80FW-CS16-TM4



Terminal No.	Color Of Wire	Signal Name [Specification]
1	R/B	-
2	G	-
3	W/R	-
5	W/B	-
6	L/Y	-
7	B	-
8	GR	-
9	GR/R	-
11	W	-
12	V	-
13	Y	-
16	L/O	-
17	GR/L	-
18	RG	-
19	L/Y	-
20	G/Y	-
21	R	-
22	GR	-
27	L/O	-
29	SB	-
30	R/L	-
31	Y/L	-
32	W/R	-
33	W/G	-
34	L/R	-
36	G	-
37	V	-
38	SHIELD	-
39	P/B	-
40	W/R	-
41	R	-
42	L/W	-
43	B/W	-
44	B	-
45	P	-
46	SHIELD	-

47	R	-
48	W	-
49	SHIELD	-
50	V	-
51	O/L	-
52	L/R	-
53	SB	-
54	V/W	-
59	L	-
60	GR	-
61	P/L	-
62	B/SB	-
63	R/Y	-
64	BR	-
70	O	-
71	W	-
72	SHIELD	-
73	B	-
74	R	-
75	G	-
76	Y	-
77	SB	-
78	LG	-
79	R/B	-
90	W/B	-
93	Y	-
94	L	-
95	L/R	-
96	R	-
97	W	-
98	V	-
99	L/W	-
100	W	-

Connector No. M135  
 Connector Name AFS CONTROL UNIT  
 Connector Type TH80FW-NH

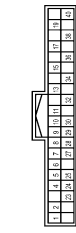

JRLWC6484GB

# EXTERIOR LIGHTING SYSTEM

< WIRING DIAGRAM >

[XENON TYPE]

## EXTERIOR LIGHTING SYSTEM

Terminal No.	Color Of Wire	Signal Name (Specification)
1	GR	IGN
2	LG/B	PSG-R
4	Y/R	PSV-R
5	LY	HSV-F
6	LG/R	HSV-R
7	P	CAN-L
8	B/O	HSG-R
9	GR	PS-R
10	B/W	HSG-F
11	R	SMR-2 (L)
13	B	SMR-1 (L)
15	W	SM-L-1 (+)
17	G	SM-L-2 (+)
19	SB	AMDS-R
21	V	HSE
23	L/O	PSV-L
24	B	GND
27	BR/Y	PSCL
28	RG	PSR
29	BR/W	PSL
30	L	CANH
32	G	SMR-T (+)
34	W	SMR-2 (+)
36	R	SM-L-1 (L)
38	B	SM-L-1 (L)
40	GR/L	AMDSL

A  
B  
C  
D  
E  
F  
G  
H  
I  
J  
K  
EXL  
M  
N  
O  
P

JRLWC6485GB

# DIAGNOSIS AND REPAIR WORK FLOW

< BASIC INSPECTION >

[XENON TYPE]

## BASIC INSPECTION

### DIAGNOSIS AND REPAIR WORK FLOW

Work Flow

INFOID:000000009010251

OVERALL SEQUENCE

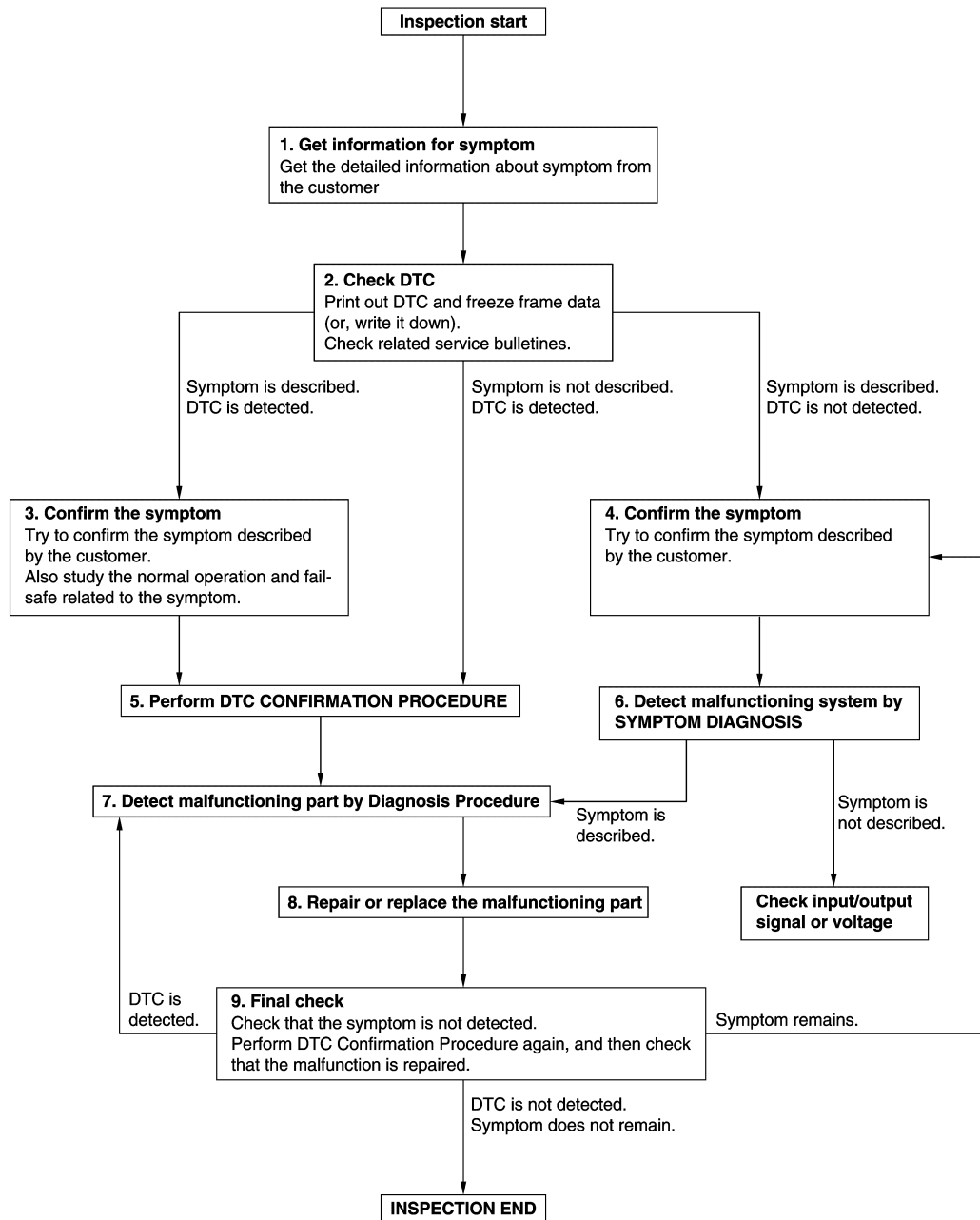

JMKIA8652GB

DETAILED FLOW

Revision: 2013 September

EXL-60

2014 QX80

# DIAGNOSIS AND REPAIR WORK FLOW

< BASIC INSPECTION >

[XENON TYPE]

## 1.GET INFORMATION FOR SYMPTOM

1. Get detailed information from the customer about the symptom (the condition and the environment when the incident/malfunction occurs).
2. Check operation condition of the function that is malfunctioning.

>> GO TO 2.

## 2.CHECK DTC

1. Check DTC.
2. Perform the following procedure if DTC is detected.
  - Record DTC and freeze frame data (Print them out using CONSULT.)
  - Erase DTC.
  - Study the relationship between the cause detected by DTC and the symptom described by the customer.
3. Check related service bulletins for information.

### Are any symptoms described and any DTC detected?

Symptom is described, DTC is detected>>GO TO 3.

Symptom is described, DTC is not detected>>GO TO 4.

Symptom is not described, DTC is detected>>GO TO 5.

## 3.CONFIRM THE SYMPTOM

Try to confirm the symptom described by the customer.

Also study the normal operation and fail-safe related to the symptom.

Verify relation between the symptom and the condition when the symptom is detected.

>> GO TO 5.

## 4.CONFIRM THE SYMPTOM

Try to confirm the symptom described by the customer.

Verify relation between the symptom and the condition when the symptom is detected.

>> GO TO 6.

## 5.PERFORM DTC CONFIRMATION PROCEDURE

Perform DTC CONFIRMATION PROCEDURE for the detected DTC, and then check that DTC is detected again. At this time, always connect CONSULT to the vehicle, and check self diagnostic results in real time. If two or more DTCs are detected, refer to DTC INSPECTION PRIORITY CHART, and determine trouble diagnosis order.

### **NOTE:**

- Freeze frame data is useful if the DTC is not detected.
- Perform Component Function Check if DTC CONFIRMATION PROCEDURE is not included on Service Manual. This simplified check procedure is an effective alternative though DTC cannot be detected during this check.

If the result of Component Function Check is NG, it is the same as the detection of DTC by DTC CONFIRMATION PROCEDURE.

### Is DTC detected?

YES >> GO TO 7.

NO >> Check according to [GI-43. "Intermittent Incident"](#).

## 6.DETECT MALFUNCTIONING SYSTEM BY SYMPTOM DIAGNOSIS

Detect malfunctioning system according to SYMPTOM DIAGNOSIS based on the confirmed symptom in step 4, and determine the trouble diagnosis order based on possible causes and symptom.

### Is the symptom described?

YES >> GO TO 7.

NO >> Monitor input data from related sensors or check voltage of related module terminals using CONSULT.

## 7.DETECT MALFUNCTIONING PART BY DIAGNOSIS PROCEDURE

A

B

C

D

E

F

G

H

I

J

K

EXL

M

N

O

P

# DIAGNOSIS AND REPAIR WORK FLOW

[XENON TYPE]

< BASIC INSPECTION >

---

Inspect according to Diagnosis Procedure of the system.

Is malfunctioning part detected?

YES >> GO TO 8.

NO >> Check according to [GI-43. "Intermittent Incident"](#).

## 8. REPAIR OR REPLACE THE MALFUNCTIONING PART

---

1. Repair or replace the malfunctioning part.
2. Reconnect parts or connectors disconnected during Diagnosis Procedure again after repair and replacement.
3. Check DTC. If DTC is detected, erase it.

>> GO TO 9.

## 9. FINAL CHECK

---

When DTC is detected in step 2, perform DTC CONFIRMATION PROCEDURE again, and then check that the malfunction is repaired securely.

When symptom is described by the customer, refer to confirmed symptom in step 3 or 4, and check that the symptom is not detected.

Is DTC detected and does symptom remain?

YES-1 >> DTC is detected: GO TO 7.

YES-2 >> Symptom remains: GO TO 4.

NO >> Before returning the vehicle to the customer, always erase DTC.

# INSPECTION AND ADJUSTMENT

< BASIC INSPECTION >

[XENON TYPE]

## INSPECTION AND ADJUSTMENT

ADDITIONAL SERVICE WHEN REPLACING CONTROL UNIT (AFS CONTROL UNIT)

ADDITIONAL SERVICE WHEN REPLACING CONTROL UNIT (AFS CONTROL UNIT) : Description

INFOID:000000009010252

Perform "LEVELIZER ADJUSTMENT" with CONSULT when replacing the AFS control unit.

ADDITIONAL SERVICE WHEN REPLACING CONTROL UNIT (AFS CONTROL UNIT) : Special Repair Requirement

INFOID:000000009010253

### 1.LEVELIZER ADJUSTMENT

Perform "LEVELIZER ADJUSTMENT".

>> Refer to [EXL-63, "LEVELIZER ADJUSTMENT : Special Repair Requirement"](#).

ADDITIONAL SERVICE WHEN REPLACING CONTROL UNIT (HEIGHT SENSOR)

ADDITIONAL SERVICE WHEN REPLACING CONTROL UNIT (HEIGHT SENSOR) : Description

INFOID:000000009010254

Perform "LEVELIZER ADJUSTMENT" with CONSULT when replacing the height sensor.

ADDITIONAL SERVICE WHEN REPLACING CONTROL UNIT (HEIGHT SENSOR) : Special Repair Requirement

INFOID:000000009010255

### 1.LEVELIZER ADJUSTMENT

Perform "LEVELIZER ADJUSTMENT".

>> Refer to [EXL-63, "LEVELIZER ADJUSTMENT : Special Repair Requirement"](#).

## LEVELIZER ADJUSTMENT

LEVELIZER ADJUSTMENT : Description

INFOID:000000009010256

Perform "LEVELIZER ADJUSTMENT" when installing, removing, and replacing the height sensor and the suspension components.

LEVELIZER ADJUSTMENT : Special Repair Requirement

INFOID:000000009010257

#### NOTE:

If perform aiming adjustment after the levelizer initialization, be sure to start the engine running after turning ignition switch OFF.

### 1.CHECK VEHICLE CONDITION

1. Park the vehicle in the straight-forward position.
2. Unload the vehicle (no passenger aboard).

>> GO TO 2.

### 2.LEVELIZER ADJUSTMENT

#### CONSULT WORK SUPPORT

1. Select "LEVELIZER ADJUSTMENT" of ADAPTIVE LIGHT work support item.
2. Select "START".
3. When "ADJUSTMENT IS COMPLETED", select "END".

#### NOTE:

A  
B  
C  
D  
E  
F  
G  
H  
I  
J  
K  
EXL  
M  
N  
O  
P

## INSPECTION AND ADJUSTMENT

[XENON TYPE]

### < BASIC INSPECTION >

If "CAN NOT BE TESTED" is indicated, AFS control unit detects that the height sensor signal changes. The levelizer adjustment is cancelled. In this case, turn the ignition switch OFF to prevent the vehicle from the height change. Perform the levelizer adjustment again.

#### Is the levelizer adjustment completed?

YES >> GO TO 3.

NO >> Perform the levelizer adjustment again.

### 3.SELF-DIAGNOSIS RESULT CHECK

Perform self-diagnosis with CONSULT. Check that any DTC is not detected.

#### Is any DTC detected?

YES >> GO TO 2.

NO >> Levelizer adjustment completed



# B2503, B2504 SWIVEL ACTUATOR

< DTC/CIRCUIT DIAGNOSIS >

[XENON TYPE]

## DTC/CIRCUIT DIAGNOSIS

### B2503, B2504 SWIVEL ACTUATOR

#### DTC Logic

INFOID:000000009010258

#### DTC DETECTION LOGIC

DTC No.	Trouble diagnosis name	DTC detection condition	Possible cause
B2503	Swivel actuator [RH]	AFS control unit indicates an applicable DTC when detecting any of the following conditions continuously for 2 seconds or more. <ul style="list-style-type: none"><li>• AFS control unit-recognized swivel position differs extremely from the swivel position sensor-input value while the swivel operating.*</li><li>• The swivel position sensor signal does not change even though AFS control unit transmits the swivel motor driving signal while the swivel operating*.</li><li>• The swivel motor short and open is detected while the swivel operating*.</li><li>• The swivel position sensor power supply is 6 V or more, or 4 V or less.</li><li>• The swivel position sensor signal is 0.25 V or less, or 4.75 V or more.</li></ul>	Swivel position sensor <ul style="list-style-type: none"><li>• Swivel position sensor</li><li>• Harness and connector</li><li>• AFS control unit</li></ul> Swivel motor <ul style="list-style-type: none"><li>• Swivel motor</li><li>• Harness and connector</li><li>• AFS control unit</li></ul>
B2504	Swivel actuator [LH]		

\*: Initialization is not included.

#### DTC CONFIRMATION PROCEDURE

##### 1. DTC ERASE

Erase the DTC memory of AFS with CONSULT.

>> GO TO 2.

##### 2. CONFIRMATION DTC SELECTION

Select "B2503" or "B2504" for confirmation.

Which DTC is confirmation?

B2503 >> GO TO 3.

B2504 >> GO TO 4.

##### 3. DTC CONFIRMATION (B2503)

1. Steer to the straight-forward position.
2. Start the engine.
3. Turn the headlamp ON.
4. Shift the selector lever to "N".
5. Steer to the right. (Rotate it once or more.)
6. Perform the self-diagnosis with CONSULT.

Is DTC "B2503" detected?

YES >> Refer to [EXL-66, "Diagnosis Procedure"](#).

NO >> Refer to [GI-43, "Intermittent Incident"](#).

##### 4. DTC CONFIRMATION (B2504)

1. Steer to the straight-forward position.
2. Start the engine.
3. Turn the headlamp ON.
4. Drive at 25 km/h (15.5 MPH) or more.
5. Steer to the left. (Rotate it once or more.)
6. Stop the vehicle.
7. Perform the self-diagnosis with CONSULT.

Is DTC "B2504" detected?

# B2503, B2504 SWIVEL ACTUATOR

[XENON TYPE]

< DTC/CIRCUIT DIAGNOSIS >

- YES >> Refer to [EXL-66, "Diagnosis Procedure"](#).  
NO >> Refer to [GI-43, "Intermittent Incident"](#).

## Diagnosis Procedure

INFOID:000000009010259

### 1. CHECK SWIVEL POSITION SENSOR SIGNAL INPUT

1. Turn ignition switch ON.
2. Check voltage between AFS control unit harness connector and ground.

(+)		Terminal	(-)	Voltage (Approx.)
AFS control unit				
Connector				
RH	M135	9	Ground	0.25 - 4.75 V
LH		29		

Is the measurement value within the standard value?

- YES >> GO TO 2.  
Less than the standard value >> GO TO 6.  
Higher than the standard value >> GO TO 9.

### 2. CHECK SWIVEL MOTOR

Check swivel motor. [EXL-69, "Component Inspection"](#).

Is the inspection result normal?

- YES >> GO TO 3.  
NO >> Replace front combination lamp.

### 3. CHECK SWIVEL MOTOR OPEN CIRCUIT

1. Turn ignition switch OFF.
2. Disconnect AFS control unit connector and headlamp swivel actuator connector.
3. Check continuity between AFS control unit harness connector and headlamp swivel actuator harness connector.

AFS control unit		Headlamp swivel actuator		Continuity	
Connector	Terminal	Connector	Terminal		
RH	M135	E123	8	Existed	
			7		
			3		
			4		
LH		15	E122		3
		17			4
		36			8
		38			7

Is the inspection result normal?

- YES >> GO TO 4.  
NO >> Repair or replace harnesses.

### 4. CHECK SWIVEL MOTOR SHORT CIRCUIT

Check continuity between AFS control unit harness connector and ground.

# B2503, B2504 SWIVEL ACTUATOR

< DTC/CIRCUIT DIAGNOSIS >

[XENON TYPE]

AFS control unit		Terminal	Ground	Continuity
Connector				Not existed
RH	M135	11	Ground	Not existed
		13		
		32		
		34		
LH		15		
		17		
		36		
		38		

Is the inspection result normal?

YES >> GO TO 5.

NO >> Repair or replace harnesses.

## 5. CHECK SWIVEL MOTOR CIRCUIT VOLTAGE OUTPUT

1. Connect AFS control unit connector.
2. Start the engine.
3. Turn the headlamp ON.
4. Select "LOW BEAM TEST RIGHT" or "LOW BEAM TEST LEFT" of ADAPTIVE LIGHT active test item.
5. With operating the test item, check voltage between AFS control unit harness connector and ground.

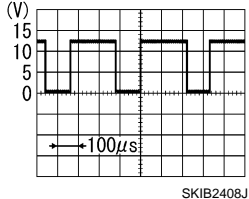
(+)		(-)	Condition	Voltage (Approx.)					
AFS control unit									
Connector	Terminal								
RH	11	Ground	Swivel motor	Active	 8 - 12 V				
	32								
	15								
LH	36					Ground	Swivel motor	Stop	9.5 - 11.5 V
	13								
	34								
17									
38									

Is the inspection result normal?

YES >> Replace front combination lamp.

NO >> Replace AFS control unit. Refer to [EXL-133, "Removal and Installation"](#)

## 6. CHECK SWIVEL POSITION SENSOR POWER SUPPLY CIRCUIT INPUT VOLTAGE

1. Turn ignition switch OFF.
2. Disconnect headlamp swivel actuator connector.
3. Turn ignition switch ON.
4. Check voltage between headlamp swivel actuator harness connector and ground.

(+)		(-)	Voltage (Approx.)
Headlamp swivel actuator			
Connector	Terminal		
RH	E123	Ground	5 V
LH	E122		

# B2503, B2504 SWIVEL ACTUATOR

[XENON TYPE]

## < DTC/CIRCUIT DIAGNOSIS >

### Is the inspection result normal?

YES >> GO TO 7.

NO >> GO TO 8.

## 7. CHECK SWIVEL POSITION SENSOR SIGNAL CIRCUIT

1. Turn ignition switch OFF.
2. Disconnect AFS control unit connector.
3. Check continuity between AFS control unit harness connector and headlamp swivel actuator harness connector.

AFS control unit		Headlamp swivel actuator		Continuity
Connector	Terminal	Connector	Terminal	
RH	M135	E123	1	Existed
LH		9		
		E122		

4. Check continuity between AFS control unit harness connector and ground.

AFS control unit		Ground	Continuity
Connector	Terminal		
RH	M135		Not existed
LH			

### Is the inspection result normal?

YES >> Replace front combination lamp.

NO >> Repair or replace harnesses.

## 8. CHECK SWIVEL POSITION SENSOR POWER SUPPLY CIRCUIT

1. Turn ignition switch OFF.
2. Disconnect AFS control unit connector.
3. Check continuity between AFS control unit harness connector and headlamp swivel actuator harness connector.

AFS control unit		Headlamp swivel actuator		Continuity
Connector	Terminal	Connector	Terminal	
RH	M135	E123	2	Existed
LH		4		
		E122		

4. Check continuity between AFS control unit harness connector and ground.

AFS control unit		Ground	Continuity
Connector	Terminal		
RH	M135		Not existed
LH			

### Is the inspection result normal?

YES >> Replace AFS control unit. Refer to [EXL-133, "Removal and Installation"](#)

NO >> Repair or replace harnesses.

## 9. CHECK SWIVEL POSITION SENSOR GROUND CIRCUIT VOLTAGE OUTPUT

Check voltage between AFS control unit harness connector and ground.

(+)		(-)	Voltage (Approx.)
AFS control unit			
Connector	Terminal	Ground	0 V
RH	M135		
LH		2	

# B2503, B2504 SWIVEL ACTUATOR

[XENON TYPE]

< DTC/CIRCUIT DIAGNOSIS >

Is the inspection result normal?

YES >> GO TO 10.

NO >> Replace AFS control unit. Refer to [EXL-133. "Removal and Installation"](#)

## 10. CHECK SWIVEL POSITION SENSOR GROUND OPEN CIRCUIT

1. Turn ignition switch OFF.
2. Disconnect AFS control unit connector and headlamp swivel actuator connector.
3. Check continuity between AFS control unit harness connector and headlamp swivel actuator harness connector.

AFS control unit		Headlamp swivel actuator		Continuity
Connector	Terminal	Connector	Terminal	
RH	M135	E123	6	Existed
LH		2		
		E122		

Is the inspection result normal?

YES >> Replace front combination lamp.

NO >> Repair or replace harnesses.

## Component Inspection

INFOID:000000009010260

## 1. CHECK SWIVEL MOTOR SINGLE PART

1. Disconnect swivel actuator connector.
2. Check resistance among each swivel actuator connector terminals.

Swivel actuator		Resistance (Approx.)
Terminal	Terminal	
3	7	7.2 Ω
4	8	
3	4	10 MΩ or more

Is the inspection result normal?

YES >> Swivel actuator is normal.

NO >> Replace front combination lamp.

A  
B  
C  
D  
E  
F  
G  
H  
I  
J  
K

EXL

# B2513 HEIGHT SENSOR UNUSUAL [FR]

< DTC/CIRCUIT DIAGNOSIS >

[XENON TYPE]

## B2513 HEIGHT SENSOR UNUSUAL [FR]

### DTC Logic

INFOID:000000009010261

### DTC DETECTION LOGIC

DTC No.	Trouble diagnosis name	DTC detection condition	Possible cause
B2513	Height sensor unusual [FR]	An applicable DTC is indicated when any of the following conditions is detected continuously for 2 seconds or more. <ul style="list-style-type: none"><li>The front height sensor power supply is 6 V or more, or 4 V or less.</li><li>The front height sensor signal is 0.25 V or less, or 4.75 V or more.</li></ul>	Front height sensor <ul style="list-style-type: none"><li>Front height sensor</li><li>Harness and connector</li><li>AFS control unit</li></ul>

### DTC CONFIRMATION PROCEDURE

#### 1. DTC ERASE

Erase the DTC memory of AFS with CONSULT.

>> GO TO 2.

#### 2. DTC CONFIRMATION

- Start the engine.
- Turn the headlamp ON.
- Select the self-diagnosis with CONSULT.
- Check the self-diagnosis result. Refer to [EXL-39, "DTC Index"](#).

Is DTC "B2513" detected?

YES >> Refer to [EXL-70, "Diagnosis Procedure"](#).

NO >> Refer to [GI-43, "Intermittent Incident"](#).

### Diagnosis Procedure

INFOID:000000009010262

#### 1. CHECK HEIGHT SENSOR SIGNAL INPUT

- Turn ignition switch ON.
- Check voltage between AFS control unit harness connector and ground.

(+)		(-)	Voltage (Approx.)
AFS control unit			
Connector	Terminal		
M135	23	Ground	0.25 - 4.75 V

Is the measurement value within the standard value?

YES >> Replace AFS control unit. Refer to [EXL-133, "Removal and Installation"](#)

Less than the standard value >>GO TO 2.

Higher than the standard value>>GO TO 5.

#### 2. CHECK HEIGHT SENSOR POWER SUPPLY CIRCUIT INPUT VOLTAGE

- Turn ignition switch OFF.
- Disconnect front height sensor connector.
- Turn ignition switch ON.
- Check voltage between front height sensor harness connector and ground.

(+)		(-)	Voltage (Approx.)
Front height sensor			
Connector	Terminal		
E208	1	Ground	5 V

# B2513 HEIGHT SENSOR UNUSUAL [FR]

[XENON TYPE]

## < DTC/CIRCUIT DIAGNOSIS >

Is the inspection result normal?

- YES >> GO TO 3.
- NO >> GO TO 4.

### 3.CHECK HEIGHT SENSOR SIGNAL CIRCUIT

1. Turn ignition switch OFF.
2. Disconnect AFS control unit connector.
3. Check continuity between AFS control unit harness connector and front height sensor harness connector.

AFS control unit		Front height sensor		Continuity
Connector	Terminal	Connector	Terminal	
M135	23	E208	2	Existed

4. Check continuity between AFS control unit harness connector and ground.

AFS control unit		Ground	Continuity
Connector	Terminal		
M135	23		Not existed

Is the inspection result normal?

- YES >> Replace front height sensor. Refer to [EXL-134, "Removal and Installation"](#).
- NO >> Repair or replace harness.

### 4.CHECK HEIGHT SENSOR POWER SUPPLY CIRCUIT

1. Turn ignition switch OFF.
2. Disconnect AFS control unit connector.
3. Check continuity between AFS control unit harness connector and front height sensor harness connector.

AFS control unit		Front height sensor		Continuity
Connector	Terminal	Connector	Terminal	
M135	5	E208	1	Existed

4. Check continuity between AFS control unit harness connector and ground.

AFS control unit		Ground	Continuity
Connector	Terminal		
M135	5		Not existed

Is the inspection result normal?

- YES >> Replace AFS control unit. Refer to [EXL-133, "Removal and Installation"](#)
- NO >> Repair or replace harness.

### 5.CHECK HEIGHT SENSOR GROUND CIRCUIT VOLTAGE OUTPUT

Check voltage between AFS control unit harness connector and ground.

(+)		(-)	Voltage (Approx.)
AFS control unit			
Connector	Terminal		
M135	10	Ground	0 V

Is the inspection result normal?

- YES >> GO TO 6.
- NO >> Replace AFS control unit. Refer to [EXL-133, "Removal and Installation"](#)

### 6.CHECK HEIGHT SENSOR GROUND OPEN CIRCUIT

1. Turn ignition switch OFF.
2. Disconnect AFS control unit connector and front height sensor connector.
3. Check continuity between AFS control unit harness connector and front height sensor harness connector.

## B2513 HEIGHT SENSOR UNUSUAL [FR]

< DTC/CIRCUIT DIAGNOSIS >

[XENON TYPE]

AFS control unit		Front height sensor		Continuity
Connector	Terminal	Connector	Terminal	
M135	10	E208	3	Existed

Is the inspection result normal?

- YES >> Replace front height sensor. Refer to [EXL-134, "Removal and Installation"](#).  
NO >> Repair or replace harness.



# B2514 HEIGHT SENSOR UNUSUAL [RR]

< DTC/CIRCUIT DIAGNOSIS >

[XENON TYPE]

## B2514 HEIGHT SENSOR UNUSUAL [RR]

### DTC Logic

INFOID:000000009010263

### DTC DETECTION LOGIC

DTC No.	Trouble diagnosis name	DTC detection condition	Possible cause
B2514	Height sensor unusual [RR]	An applicable DTC is indicated when any of the following conditions is detected continuously for 2 seconds or more. <ul style="list-style-type: none"> <li>The rear height sensor power supply is 6 V or more, or 4 V or less.</li> <li>The rear height sensor signal is 0.25 V or less, or 4.75 V or more.</li> </ul>	<ul style="list-style-type: none"> <li>Rear height sensor</li> <li>Rear height sensor</li> <li>Harness and connector</li> <li>AFS control unit</li> </ul>

### DTC CONFIRMATION PROCEDURE

#### 1. DTC ERASE

Erase the DTC memory of AFS with CONSULT.

>> GO TO 2.

#### 2. DTC CONFIRMATION

- Start the engine.
- Turn the headlamp ON.
- Select the self-diagnosis with CONSULT.
- Check the self-diagnosis result. Refer to [EXL-39, "DTC Index"](#).

Is DTC "B2514" detected?

- YES >> Refer to [EXL-73, "Diagnosis Procedure"](#).  
 NO >> Refer to [GI-43, "Intermittent Incident"](#).

### Diagnosis Procedure

INFOID:000000009010264

#### 1. CHECK HEIGHT SENSOR SIGNAL INPUT

- Turn ignition switch ON.
- Check voltage between AFS control unit harness connector and ground.

(+)		(-)	Voltage (Approx.)
AFS control unit			
Connector	Terminal		
M135	28	Ground	0.25 - 4.75 V

Is the measurement value within the standard value?

- YES >> Replace AFS control unit. Refer to [EXL-133, "Removal and Installation"](#)  
 Less than the standard value >> GO TO 2.  
 Higher than the standard value >> GO TO 5.

#### 2. CHECK HEIGHT SENSOR POWER SUPPLY CIRCUIT INPUT VOLTAGE

- Turn ignition switch OFF.
- Disconnect rear height sensor connector.
- Turn ignition switch ON.
- Check voltage between rear height sensor harness connector and ground.

(+)		(-)	Voltage (Approx.)
Rear height sensor			
Connector	Terminal		
C15	1	Ground	5 V

## B2514 HEIGHT SENSOR UNUSUAL [RR]

[XENON TYPE]

< DTC/CIRCUIT DIAGNOSIS >

Is the inspection result normal?

- YES >> GO TO 3.
- NO >> GO TO 4.

### 3.CHECK HEIGHT SENSOR SIGNAL CIRCUIT

1. Turn ignition switch OFF.
2. Disconnect AFS control unit connector.
3. Check continuity between AFS control unit harness connector and rear height sensor harness connector.

AFS control unit		Rear height sensor		Continuity
Connector	Terminal	Connector	Terminal	
M135	28	C15	2	Existed

4. Check continuity between AFS control unit harness connector and ground.

AFS control unit		Ground	Continuity
Connector	Terminal		
M135	28		Not existed

Is the inspection result normal?

- YES >> Replace rear height sensor. Refer to [EXL-134, "Removal and Installation"](#).
- NO >> Repair or replace harness.

### 4.CHECK HEIGHT SENSOR POWER SUPPLY CIRCUIT

1. Turn ignition switch OFF.
2. Disconnect AFS control unit connector.
3. Check continuity between AFS control unit harness connector and rear height sensor harness connector.

AFS control unit		Rear height sensor		Continuity
Connector	Terminal	Connector	Terminal	
M135	6	C15	1	Existed

4. Check continuity between AFS control unit harness connector and ground.

AFS control unit		Ground	Continuity
Connector	Terminal		
M135	6		Not existed

Is the inspection result normal?

- YES >> Replace AFS control unit. Refer to [EXL-133, "Removal and Installation"](#)
- NO >> Repair or replace harness.

### 5.CHECK HEIGHT SENSOR GROUND CIRCUIT VOLTAGE OUTPUT

Check voltage between AFS control unit harness connector and ground.

(+)		(-)	Voltage (Approx.)
AFS control unit			
Connector	Terminal		
M135	8	Ground	0 V

Is the inspection result normal?

- YES >> GO TO 6.
- NO >> Replace AFS control unit. Refer to [EXL-133, "Removal and Installation"](#)

### 6.CHECK HEIGHT SENSOR GROUND OPEN CIRCUIT

1. Turn ignition switch OFF.
2. Disconnect AFS control unit connector and rear height sensor connector.
3. Check continuity between AFS control unit harness connector and rear height sensor harness connector.

# B2514 HEIGHT SENSOR UNUSUAL [RR]

< DTC/CIRCUIT DIAGNOSIS >

[XENON TYPE]

AFS control unit		Rear height sensor		Continuity
Connector	Terminal	Connector	Terminal	
M135	8	C15	3	Existed

Is the inspection result normal?

YES >> Replace rear height sensor. Refer to [EXL-134, "Removal and Installation"](#).

NO >> Repair or replace harness.

A  
B  
C  
D  
E  
F  
G  
H  
I  
J  
K  
EXL  
M  
N  
O  
P

# B2516 SHIFT SIGNAL [P, R]

[XENON TYPE]

< DTC/CIRCUIT DIAGNOSIS >

## B2516 SHIFT SIGNAL [P, R]

### DTC Logic

INFOID:000000009010265

### DTC DETECTION LOGIC

DTC No.	Trouble diagnosis name	DTC detection condition	Possible causes
B2516	Shift signal [P, R]	The shift position signal is not received.	<ul style="list-style-type: none"><li>• TCM</li><li>• AFS control unit</li></ul>

### DTC CONFIRMATION PROCEDURE

#### 1. DTC ERASE

Erase the DTC memory of AFS with CONSULT.

>> GO TO 2.

#### 2. DTC CONFIRMATION

1. Turn ignition ON.
2. Select the self-diagnosis with CONSULT.
3. Check the self-diagnosis result. Refer to [EXL-39, "DTC Index"](#).

Is DTC "B2516" detected?

- YES >> Refer to [EXL-76, "Diagnosis Procedure"](#).  
NO >> Refer to [GI-43, "Intermittent Incident"](#).

### Diagnosis Procedure

INFOID:000000009010266

#### 1. TCM SELF-DIAGNOSIS

Check the self-diagnosis result with CONSULT. Check that TCM does not detect any DTCs.

Is any DTC detected?

- YES >> Check TCM. Refer to [TM-82, "DTC Index"](#).  
NO >> GO TO 2.

#### 2. DTC ERASE

Erase the DTC memory of AFS with CONSULT.

Is the memory erased?

- YES >> INSPECTION END.  
NO >> Replace AFS control unit. Refer to [EXL-133, "Removal and Installation"](#)

# B2517 VEHICLE SPEED SIGNAL

< DTC/CIRCUIT DIAGNOSIS >

[XENON TYPE]

## B2517 VEHICLE SPEED SIGNAL

### DTC Logic

INFOID:000000009010267

### DTC DETECTION LOGIC

DTC No.	Trouble diagnosis name	DTC detection condition	Possible causes
B2517	Vehicle speed signal	The vehicle speed signal is not received.	<ul style="list-style-type: none"><li>• Combination meter</li><li>• AFS control unit</li></ul>

### DTC CONFIRMATION PROCEDURE

#### 1. DTC ERASE

Erase the DTC memory of AFS with CONSULT.

>> GO TO 2.

#### 2. DTC CONFIRMATION

1. Turn ignition ON.
2. Select the self-diagnosis with CONSULT.
3. Check the self-diagnosis result. Refer to [EXL-39, "DTC Index"](#).

Is DTC "B2517" detected?

- YES >> Refer to [EXL-77, "Diagnosis Procedure"](#).  
NO >> Refer to [GI-43, "Intermittent Incident"](#).

### Diagnosis Procedure

INFOID:000000009010268

#### 1. COMBINATION METER SELF-DIAGNOSIS

Check the self-diagnosis result with CONSULT. Check that the combination meter does not detect any DTCs.

Is any DTC detected?

- YES >> Check the combination meter Refer to [MWI-44, "DTC Index"](#).  
NO >> GO TO 2.

#### 2. DTC ERASE

Erase the DTC memory of AFS with CONSULT.

Is the memory erased?

- YES >> INSPECTION END.  
NO >> Replace AFS control unit. Refer to [EXL-133, "Removal and Installation"](#)

A  
B  
C  
D  
E  
F  
G  
H  
I  
J  
K  
EXL  
M  
N  
O  
P

# B2519 LEVELIZER CALIBRATION

< DTC/CIRCUIT DIAGNOSIS >

[XENON TYPE]

## B2519 LEVELIZER CALIBRATION

### DTC Logic

INFOID:000000009010269

DTC No.	Trouble diagnosis name	DTC detection condition	Possible causes
B2519	Levelizer calibration	The height sensor adjustment position is not recognized.	AFS control unit

### Diagnosis Procedure

INFOID:000000009010270

#### 1.LEVELIZER ADJUSTMENT

Perform the levelizer adjustment.

>> Refer to [EXL-63. "LEVELIZER ADJUSTMENT : Special Repair Requirement"](#).

# B2521 ECU CIRCUIT

< DTC/CIRCUIT DIAGNOSIS >

[XENON TYPE]

## B2521 ECU CIRCUIT

### DTC Logic

INFOID:000000009010271

### DTC DETECTION LOGIC

DTC No.	Trouble diagnosis name	Error detection condition	Possible cause
B2512	ECU circuit	<ul style="list-style-type: none"> <li>• AFS control unit indicates an applicable DTC when detecting any of the following conditions continuously for 2 seconds or more.</li> <li>- The swivel position sensor is shorted to the power supply or the ground.</li> <li>- The swivel position sensor signal is shorted to the ground.</li> <li>- The height sensor power supply is shorted to the power supply or the ground.</li> <li>- The height sensor signal is shorted to the ground.</li> <li>• AFS control unit RAM/ROM error</li> </ul>	Swivel position sensor <ul style="list-style-type: none"> <li>• Swivel position sensor</li> <li>• Harness and connector</li> <li>• AFS control unit</li> </ul> Height sensor <ul style="list-style-type: none"> <li>• Height sensor</li> <li>• Harness and connector</li> <li>• AFS control unit</li> </ul> AFS control unit (RAM/ROM) <ul style="list-style-type: none"> <li>• AFS control unit</li> </ul>

### DTC CONFIRMATION PROCEDURE

#### 1. DTC ERASE

Erase the DTC memory of AFS with CONSULT.

>> GO TO 2.

#### 2. DTC CONFIRMATION PROCEDURE

1. Turn ignition ON.
2. Select the self-diagnosis with CONSULT.
3. Check the self-diagnosis result. Refer to [EXL-39, "DTC Index"](#).

Is DTC "B2521" detected?

- YES >> Refer to [EXL-79, "Diagnosis Procedure"](#).  
 NO >> Refer to [GI-43, "Intermittent Incident"](#).

### Diagnosis Procedure

INFOID:000000009010272

#### 1. CHECK EACH SENSOR POWER SUPPLY

1. Turn ignition switch ON.
2. Check voltage between AFS control unit harness connector and ground.

(+)		(-)	Voltage (Approx.)
AFS control unit			
Connector	Terminal	Ground	5 V
M135	4		
	5		
	6		
	24		

Is the measurement value within the standard value?

- YES >> GO TO 2.  
 Less than the standard value >> GO TO 3.  
 Higher than the standard value >> GO TO 4.

#### 2. CHECK EACH SENSOR SIGNAL

Check voltage between AFS control unit harness connector and ground.

# B2521 ECU CIRCUIT

< DTC/CIRCUIT DIAGNOSIS >

[XENON TYPE]

(+)		(-)	Voltage (Approx.)
AFS control unit			
Connector	Terminal	Ground	0.25 - 4.75 V
M135	9		
	23		
	28		
	29		

Is the measurement value within the standard value?

YES >> Replace AFS control unit. Refer to [EXL-133, "Removal and Installation"](#)

Less than the standard value >>GO TO 5.

Higher than the standard value>>GO TO 6.

### 3.CHECK EACH SENSOR POWER SUPPLY SHORT CIRCUIT

1. Turn ignition switch OFF.
2. Disconnect AFS control unit connector.
3. Check continuity between AFS control unit harness connector and ground.

AFS control unit		Ground	Continuity
Connector	Terminal		Not existed
M135	4		
	5		
	6		
	24		

Is the inspection result normal?

YES >> Replace AFS control unit. Refer to [EXL-133, "Removal and Installation"](#)

NO >> Repair or replace harness.

### 4.CHECK EACH SENSOR POWER SUPPLY SHORT CIRCUIT

1. Turn ignition switch OFF.
2. Disconnect AFS control unit connector.
3. Check voltage between AFS control unit harness connector and ground.

(+)		(-)	Voltage (Approx.)
AFS control unit			
Connector	Terminal	Ground	0 V
M135	4		
	5		
	6		
	24		

Is the inspection result normal?

YES >> Replace AFS control unit. Refer to [EXL-133, "Removal and Installation"](#)

NO >> Repair or replace harness.

### 5.CHECK EACH SENSOR SIGNAL SHORT CIRCUIT

1. Turn ignition switch OFF.
2. Disconnect AFS control unit connector.
3. Check continuity between AFS control unit harness connector and ground.



# B2521 ECU CIRCUIT

< DTC/CIRCUIT DIAGNOSIS >

[XENON TYPE]

AFS control unit		Ground	Continuity
Connector	Terminal		
M135	9	Ground	Not existed
	23		
	28		
	29		

Is the inspection result normal?

YES >> Replace AFS control unit. Refer to [EXL-133, "Removal and Installation"](#)

NO >> Repair or replace harness.

## 6. CHECK EACH SENSOR SIGNAL SHORT CIRCUIT

1. Turn ignition switch OFF.
2. Disconnect AFS control unit connector.
3. Turn ignition switch ON.
4. Check voltage between AFS control unit harness connector and ground.

AFS control unit		(-)	Voltage (Approx.)
Connector	Terminal		
M135	9	Ground	0 V
	23		
	28		
	29		

Is the inspection result normal?

YES >> Replace AFS control unit. Refer to [EXL-133, "Removal and Installation"](#)

NO >> Repair or replace harness.

A  
B  
C  
D  
E  
F  
G  
H  
I  
J  
K  
M  
N  
O  
P

EXL

# C0126 STEERING ANGLE SENSOR SIGNAL

< DTC/CIRCUIT DIAGNOSIS >

[XENON TYPE]

## C0126 STEERING ANGLE SENSOR SIGNAL

### DTC Logic

INFOID:000000009010273

### DTC DETECTION LOGIC

DTC No.	Trouble diagnosis name	DTC detection condition	Possible causes
C0126	Steering angle sensor signal	In any of the following conditions <ul style="list-style-type: none"> <li>The steering angle sensor signal is not received.</li> <li>The steering angle sensor signal error is received.</li> <li>Out-of-standard signal (-900°-+900°) is received.</li> </ul>	<ul style="list-style-type: none"> <li>Steering angle sensor</li> <li>AFS control unit</li> </ul>

### DTC CONFIRMATION PROCEDURE

#### 1. DTC ERASE

Erase the DTC memory of AFS with CONSULT.

>> GO TO 2.

#### 2. DTC CONFIRMATION

- Start the engine.
- Turn the steering wheel to the maximum right/left.
- Select the self-diagnosis with CONSULT.
- Check the self-diagnosis result. Refer to [EXL-39, "DTC Index"](#).

Is DTC "C0126" detected?

- YES >> Refer to [EXL-82, "Diagnosis Procedure"](#).  
NO >> Refer to [GI-43, "Intermittent Incident"](#).

### Diagnosis Procedure

INFOID:000000009010274

#### 1. ABS ACTUATOR AND ELECTRICAL UNIT (CONTROL UNIT) SELF-DIAGNOSIS

Check the self-diagnosis result with CONSULT. Check that ABS actuator and electrical unit (control unit) does not detect any DTCs.

Is any DTC detected?

- YES >> Check ABS actuator and electrical unit (control unit). Refer to [BRC-50, "DTC Index"](#).  
NO >> GO TO 2.

#### 2. DTC ERASE

Erase DTC memory of AFS with CONSULT.

Is the memory erased?

- YES >> Inspection end.  
NO >> Replace AFS control unit. Refer to [EXL-133, "Removal and Installation"](#)

# C0428 STEERING ANGLE SENSOR CALIBRATION

< DTC/CIRCUIT DIAGNOSIS >

[XENON TYPE]

## C0428 STEERING ANGLE SENSOR CALIBRATION

### DTC Logic

INFOID:000000009010275

DTC No.	Trouble diagnosis name	DTC detection condition	Possible causes
C0428	Steering angle sensor calibration	The steering angle sensor neutral position is not recognized.	Steering angle sensor

### Diagnosis Procedure

INFOID:000000009010276

#### 1. STEERING ANGLE SENSOR NEUTRAL POSITION ADJUSTMENT

Perform the steering angle sensor neutral position adjustment.

**NOTE:**

Perform the steering angle sensor neutral position adjustment on VDC side. VDC may activate incorrectly.

>> Refer to [BRC-62, "Work Procedure"](#).

A  
B  
C  
D  
E  
F  
G  
H  
I  
J  
K  
EXL  
M  
N  
O  
P

EXL

# U1000 CAN COMM CIRCUIT

< DTC/CIRCUIT DIAGNOSIS >

[XENON TYPE]

## U1000 CAN COMM CIRCUIT

### Description

INFOID:000000009010277

CAN (Controller Area Network) is the serial transmission for real time application. CAN is the multiplex communication for the vehicle with superior data transmission speed and error detection ability. Many electronic control units are equipped on the vehicle. These control units do not operate individually, but associates with other control units by sharing information. In CAN communication, each control unit is connected with two communication lines (CAN-H and CAN-L). Much information is transmitted with fewer communication lines than before. Each control unit transmits/receives data and reads the necessary data only.

CAN Communication Signal Chart. Refer to [LAN-31, "CAN COMMUNICATION SYSTEM : CAN System Specification Chart"](#).

### DTC Logic

INFOID:000000009010278

### DTC DETECTION LOGIC

DTC No.	Trouble diagnosis name	DTC detection condition	Possible causes
U1000	CAN communication circuit	When AFS control unit does not transmit/receive CAN communication signal continuously for 2 seconds or more	CAN communication system

### Diagnosis Procedure

INFOID:000000009010279

#### 1. PERFORM SELF DIAGNOSTIC

1. Turn ignition switch ON and wait for 2 seconds or more.
2. Check "Self Diagnostic Result".

Is "CAN COMM CIRCUIT" displayed?

- YES >> Refer to [LAN-22, "Trouble Diagnosis Flow Chart"](#).  
NO >> Refer to [GI-43, "Intermittent Incident"](#).

# U1010 CONTROL UNIT (CAN)

< DTC/CIRCUIT DIAGNOSIS >

[XENON TYPE]

## U1010 CONTROL UNIT (CAN)

### DTC Logic

INFOID:000000009010280

### DTC DETECTION LOGIC

DTC No.	Trouble diagnosis name	DTC detection condition	Possible cause
U1010	Control unit (CAN)	AFS control unit detected internal CAN communication circuit malfunction.	AFS control unit

### Diagnosis Procedure

INFOID:000000009010281

#### 1. REPLACE AFS CONTROL UNIT

When DTC [U1010] is detected, replace AFS control unit.

>> Replace AFS control unit. Refer to [EXL-133, "Removal and Installation"](#)

A  
B  
C  
D  
E  
F  
G  
H  
I  
J  
K  
M  
N  
O  
P

EXL

# POWER SUPPLY AND GROUND CIRCUIT

< DTC/CIRCUIT DIAGNOSIS >

[XENON TYPE]

## POWER SUPPLY AND GROUND CIRCUIT

### AFS CONTROL UNIT

#### AFS CONTROL UNIT : Diagnosis Procedure

INFOID:000000009010282

### 1. FUSE INSPECTION

Check that the following fuses are not fusing.

Signal name	Connection position	Fuse No.	Capacity
Ignition power supply	FUSE BLOCK (J/B)	3	10 A

Is the inspection result normal?

YES >> GO TO 2.

NO >> Repair the applicable circuit. And then replace the fuse.

### 2. CHECK POWER SUPPLY CIRCUIT

1. Turn ignition switch OFF.
2. Disconnect AFS control unit harness connector.
3. Turn ignition switch ON.
4. Check voltage between AFS control unit harness connector and ground.

(+)		(-)	Voltage (Approx.)
AFS control unit			
Connector	Terminal	Ground	Battery voltage
M135	1		

Is the inspection result normal?

YES >> GO TO 3.

NO >> Repair harness or connector.

### 3. CHECK GROUND CIRCUIT

1. Turn ignition switch OFF.
2. Check continuity between AFS control unit harness connectors and ground.

AFS control unit		Ground	Continuity
Connector	Terminal		
M135	25		Existed

Is the inspection result normal?

YES >> Power supply and ground circuit are normal.

NO >> Repair harness or connector.

# HEADLAMP (HI) CIRCUIT

< DTC/CIRCUIT DIAGNOSIS >

[XENON TYPE]

## HEADLAMP (HI) CIRCUIT

### Component Function Check

INFOID:000000009010284

#### 1. CHECK HEADLAMP (HI) OPERATION

##### CONSULT ACTIVE TEST

1. Select "EXTERNAL LAMPS" of IPDM E/R active test item.
2. With operating the test items, check that the headlamp (HI) is turned ON.

**Hi** : Headlamp (HI) ON  
**Off** : Headlamp (HI) OFF

##### NOTE:

ON/OFF is repeated 1 second each.

Is the inspection result normal?

- YES >> Headlamp (HI) circuit is normal.  
NO >> Refer to [EXL-87. "Diagnosis Procedure"](#).

### Diagnosis Procedure

INFOID:000000009010285

#### 1. CHECK HEADLAMP (HI) OUTPUT VOLTAGE

##### CONSULT ACTIVE TEST

1. Turn ignition switch OFF.
2. Disconnect front combination lamp connector.
3. Turn ignition switch ON.
4. Select "EXTERNAL LAMPS" of IPDM E/R active test item.
5. With operating the test items, check voltage between IPDM E/R harness connector and ground.

(+)		Terminal	(-)	Test item	Voltage (Approx.)	
IPDM E/R						
Connector						
RH	E15	49	Ground	EXTERNAL LAMPS	Hi	Battery voltage
					Off	0 V
LH		50			Hi	Battery voltage
					Off	0 V

Is the inspection result normal?

- YES >> GO TO 2.  
NO >> GO TO 3.

#### 2. CHECK HEADLAMP (HI) OPEN CIRCUIT

1. Turn ignition switch OFF.
2. Disconnect IPDM E/R connector.
3. Check continuity between IPDM E/R harness connector and front combination lamp harness connector.

IPDM E/R		Front combination lamp		Continuity
Connector	Terminal	Connector	Terminal	
RH	E15	E119	6	Existed
LH		49		
		E118		

Is the inspection result normal?

- YES >> GO TO 5.  
NO >> Repair or replace harness.

#### 3. CHECK HEADLAMP (HI) FUSE

1. Turn ignition switch OFF.

# HEADLAMP (HI) CIRCUIT

[XENON TYPE]

## < DTC/CIRCUIT DIAGNOSIS >

2. Check that the following fuses are not fusing.

Unit	Location	Fuse No.	Capacity
Headlamp HI (RH)	IPDM E/R	#51	10 A
Headlamp HI (LH)		#52	

### Is the inspection result normal?

YES >> Replace IPDM E/R.

NO >> GO TO 4.

## 4. CHECK HEADLAMP HIGH (HI) SHORT CIRCUIT

1. Disconnect IPDM E/R connector.
2. Check continuity between IPDM E/R harness connector and ground.

IPDM E/R			Ground	Continuity
Connector		Terminal		
RH	E15	49		Not existed
LH		50		

### Is the inspection result normal?

YES >> Replace fuse. (Replace IPDM E/R if the fuse is fusing again.)

NO >> Repair or replace harness. And then replace the fuse.

## 5. CHECK HEADLAMP (HI) GROUND OPEN CIRCUIT

1. Turn ignition switch OFF.
2. Disconnect front combination lamp connector.
3. Check continuity between front combination lamp harness connector and ground.

Front combination lamp			Ground	Continuity
Connector		Terminal		
RH	E119	2		Existed
LH	E118			

### Is the inspection result normal?

YES >> Replace front combination lamp.

NO >> Repair or replace harness.



# HEADLAMP (LO) CIRCUIT

< DTC/CIRCUIT DIAGNOSIS >

[XENON TYPE]

## HEADLAMP (LO) CIRCUIT

### Component Function Check

INFOID:000000009010286

#### 1.CHECK HEADLAMP (LO) OPERATION

##### CONSULT ACTIVE TEST

1. Select "EXTERNAL LAMPS" of IPDM E/R active test item.
2. With operating the test items, check that the headlamp (LO) is turned ON.

**Lo** : Headlamp (LO) ON

**Off** : Headlamp (LO) OFF

Is the inspection result normal?

- YES >> Headlamp (LO) is normal.  
 NO >> Refer to [EXL-89, "Diagnosis Procedure"](#).

### Diagnosis Procedure

INFOID:000000009010287

#### 1.CHECK HEADLAMP (LO) OUTPUT VOLTAGE

##### CONSULT ACTIVE TEST

1. Turn ignition switch OFF.
2. Disconnect front combination lamp connector.
3. Turn ignition switch ON.
4. Select "EXTERNAL LAMPS" of IPDM E/R active test item.
5. With operating the test items, check voltage between IPDM E/R harness connector and ground.

(+)			(-)	Test item	Voltage (Approx.)		
IPDM E/R							
Connector	Terminal		Ground	EXTERNAL LAMPS			
RH	E15	52				Lo	Battery voltage
		Off				0 V	
LH	E15	51				Lo	Battery voltage
		Off	0 V				

Is the inspection result normal?

- YES >> GO TO 2.  
 NO >> GO TO 3.

#### 2.CHECK HEADLAMP (LO) OPEN CIRCUIT

1. Turn ignition switch OFF.
2. Disconnect IPDM E/R connector.
3. Check continuity between IPDM E/R harness connector and front combination lamp harness connector.

IPDM E/R			Front combination lamp		Continuity
Connector	Terminal		Connector	Terminal	
RH	E15	52	E119	5	Existed
LH		51	E118		

Is the inspection result normal?

- YES >> GO TO 5.  
 NO >> Repair or replace harness.

#### 3.CHECK HEADLAMP (LO) FUSE

1. Turn ignition switch OFF.
2. Check that the following fuses are not fusing.

A  
B  
C  
D  
E  
F  
G  
H  
I  
J  
K  
M  
N  
O  
P

EXL

# HEADLAMP (LO) CIRCUIT

< DTC/CIRCUIT DIAGNOSIS >

[XENON TYPE]

Unit	Lotion	Fuse No.	Capacity
Headlamp LO (RH)	IPDM E/R	#54	15 A
Headlamp LO (LH)		#53	

Is the inspection result normal?

YES >> Replace IPDM E/R.

NO >> GO TO 4.

## 4. CHECK HEADLAMP (LO) SHORT CIRCUIT

1. Disconnect IPDM E/R connector.
2. Check continuity between IPDM E/R harness connector and ground.

IPDM E/R			Ground	Continuity
Connector		Terminal		
RH	E15	52		Not existed
LH		51		

Is the inspection result normal?

YES >> Replace fuse. (Replace IPDM E/R if the fuse is fusing again.)

NO >> Repair or replace harness. And then replace the fuse.

## 5. CHECK HEADLAMP (LO) GROUND OPEN CIRCUIT

1. Turn ignition switch OFF.
2. Disconnect front combination lamp connector.
3. Check continuity between front combination lamp harness connector and ground.

Front combination lamp			Ground	Continuity
Connector		Terminal		
RH	E119	1		Existed
LH	E118			

Is the inspection result normal?

YES >> Perform the xenon headlamp diagnosis. Refer to [EXL-91, "Diagnosis Procedure"](#).

NO >> Repair or replace harness.

# XENON HEADLAMP

< DTC/CIRCUIT DIAGNOSIS >

[XENON TYPE]

## XENON HEADLAMP

### Diagnosis Procedure

INFOID:000000009010288

#### 1.CHECK XENON BULB

Install the normal bulb to the applicable headlamp. Turn the lighting switch ON.

Is the headlamp turned ON?

YES >> Replace xenon bulb.

NO >> GO TO 2.

#### 2.CHECK HID CONTROL UNIT

Install the normal HID control unit to the applicable headlamp. Turn the lighting switch ON

Is the headlamp turned ON?

YES >> Replace HID control unit.

NO >> Xenon headlamp is normal. Check headlamp control system.

A  
B  
C  
D  
E  
F  
G  
H  
I  
J  
K  
EXL  
M  
N  
O  
P

# HEADLAMP LEVELIZER CIRCUIT

< DTC/CIRCUIT DIAGNOSIS >

[XENON TYPE]

## HEADLAMP LEVELIZER CIRCUIT

### Component Function Check

INFOID:000000009010289

#### 1. CHECK HEADLAMP AIMING MOTOR OPERATION

##### CONSULT ACTIVE TEST

1. Start the engine.
2. Turn the lighting switch 2ND.
3. Select "LEVELIZER TEST" of ADAPTIVE LIGHT active test item.
4. With operating the test item, check the operation.

Test item	Optical axis
LEVELIZER TEST	
Origin	Standard position
Peak	Lowest position

Is the operation normal?

- YES >> Headlamp levelizer circuit is normal.  
 NO >> Refer to [EXL-92, "Diagnosis Procedure"](#).

### Diagnosis Procedure

INFOID:000000009010290

#### 1. CHECK AIMING MOTOR DRIVE SIGNAL OUTPUT

##### CONSULT ACTIVE TEST

1. Start the engine.
2. Turn light switch 2ND.
3. Select "LEVELIZER TEST" of ADAPTIVE LIGHT active test item.
4. With operating the test item, check voltage between AFS control unit harness connector and ground.

(+)		(-)	Test item	Voltage (Approx.)	
AFS control unit					
Connector	Terminal				
RH	M135	Ground	LEVELIZER TEST	Origin	7.5 V
				Peak	7.3 V
LH	40			Origin	7.5 V
				Peak	7.3 V

Is the inspection result normal?

- YES >> GO TO 2.  
 NO >> GO TO 3.

#### 2. CHECK AIMING MOTOR DRIVE SIGNAL OPEN CIRCUIT

1. Turn ignition switch OFF.
2. Disconnect AFS control unit connector and headlamp aiming motor connector.
3. Check continuity between AFS control unit harness connector and head lamp aiming motor harness connector.

AFS control unit		Headlamp aiming motor		Continuity
Connector	Terminal	Connector	Terminal	
RH	M135	E121	1	Existed
LH		E120		

Is the inspection result normal?

- YES >> Replace front combination lamp.  
 NO >> Repair or replace harness.

# HEADLAMP LEVELIZER CIRCUIT

< DTC/CIRCUIT DIAGNOSIS >

[XENON TYPE]

## 3. CHECK AIMING MOTOR DRIVE SIGNAL SHORT CIRCUIT

1. Turn ignition switch OFF.
2. Disconnect AFS control unit connector and headlamp aiming motor connector.
3. Check continuity between AFS control unit harness connector and ground.

AFS control unit		Ground	Continuity
Connector	Terminal		
RH	M135	19	Not existed
LH		40	

Is the inspection result normal?

- YES >> Replace AFS control unit. Refer to [EXL-133, "Removal and Installation"](#)  
NO >> Repair or replace harness.

A  
B  
C  
D  
E  
F  
G  
H  
I  
J  
K  
M  
N  
O  
P

EXL

# HEADLAMP AIMING SYSTEM (MANUAL)

< DTC/CIRCUIT DIAGNOSIS >

[XENON TYPE]

## HEADLAMP AIMING SYSTEM (MANUAL)

### Component Inspection

INFOID:000000009010291

#### 1. CHECK HEADLAMP AIMING SWITCH

1. Remove headlamp aiming switch.
2. Check resistance among each headlamp aiming switch terminal.

Headlamp aiming switch		Condition	Resistance (Approx.)
Terminal		Switch position	
1	2	0	A: 910 Ω
		1	B: 680 Ω
		2	C: 510 Ω
		3	D: 390 Ω
	3	—	E: 390 Ω

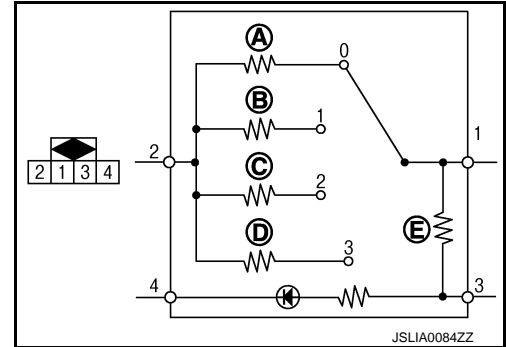

Is the inspection result normal?

- YES >> Headlamp aiming switch is normal.  
 NO >> Replace the headlamp aiming switch.

# FRONT FOG LAMP CIRCUIT

< DTC/CIRCUIT DIAGNOSIS >

[XENON TYPE]

## FRONT FOG LAMP CIRCUIT

### Component Function Check

INFOID:000000009010292

#### 1.CHECK FRONT FOG LAMP OPERATION

##### CONSULT ACTIVE TEST

1. Select "EXTERNAL LAMPS" of IPDM E/R active test item.
2. With operating the test items, check that the front fog lamp is turned ON.

**Fog** : Front fog lamp ON  
**Off** : Front fog lamp OFF

##### Is the inspection result normal?

- YES >> Front fog lamp circuit is normal.  
 NO >> Refer to [EXL-95, "Diagnosis Procedure"](#).

### Diagnosis Procedure

INFOID:000000009010293

#### 1.CHECK FRONT FOG LAMP FUSE

1. Turn ignition switch OFF.
2. Check that the following fuse is not fusing.

Unit	Location	Fuse No.	Capacity
Front fog lamp	IPDM E/R	#50	15 A

##### Is the inspection result normal?

- YES >> GO TO 3.  
 NO >> GO TO 2.

#### 2.CHECK FRONT FOG LAMP SHORT CIRCUIT

1. Disconnect front fog lamp connector.
2. Check continuity between IPDM E/R harness connector and ground.

IPDM E/R		Ground	Continuity
Connector	Terminal		
RH	E12	19	Not existed
LH		20	

##### Is the inspection result normal?

- YES >> Replace fuse. (Replace IPDM E/R if the fuse is fusing again.)  
 NO >> Repair or replace harness. And then replace the fuse.

#### 3.CHECK FRONT FOG LAMP BULB

Check the applicable lamp bulb.

##### Is the inspection result normal?

- YES >> GO TO 4.  
 NO >> Replace bulb.

#### 4.CHECK FRONT FOG LAMP OUTPUT VOLTAGE

##### CONSULT ACTIVE TEST

1. Disconnect front fog lamp connector.
2. Turn ignition switch ON.
3. Select "EXTERNAL LAMPS" of IPDM E/R active test item.
4. With operating the test items, check voltage between IPDM E/R harness connector and ground.

# FRONT FOG LAMP CIRCUIT

< DTC/CIRCUIT DIAGNOSIS >

[XENON TYPE]

(+)			(-)	Test item	Voltage (Approx.)		
IPDM E/R							
Connector	Terminal						
RH	E12	19	Ground	EXTERNAL LAMPS	Fog	Battery voltage	
						Off	0 V
LH		20				Fog	Battery voltage
						Off	0 V

Is the inspection result normal?

YES >> GO TO 5.

NO >> Replace IPDM E/R.

## 5. CHECK FRONT FOG LAMP OPEN CIRCUIT

1. Turn ignition switch OFF.
2. Disconnect IPDM E/R connector.
3. Check continuity between IPDM E/R harness connector and front fog lamp harness connector.

IPDM E/R			Front fog lamp		Continuity
Connector	Terminal		Connector	Terminal	
RH	E12	19	E48	1	Existed
LH			20		

Is the inspection result normal?

YES >> GO TO 6.

NO >> Repair or replace harness.

## 6. CHECK FRONT FOG LAMP GROUND CIRCUIT OPEN CIRCUIT

Check continuity between front fog lamp harness connector and ground.

Front fog lamp			Ground	Continuity
Connector	Terminal			
RH	E48	2		Ground
LH	E30			

Is the inspection result normal?

YES >> Replace front fog lamp.

NO >> Repair or replace harness.



# PARKING LAMP CIRCUIT

< DTC/CIRCUIT DIAGNOSIS >

[XENON TYPE]

## PARKING LAMP CIRCUIT

### Component Function Check

INFOID:000000009010294

#### 1.CHECK PARKING LAMP OPERATION

##### CONSULT ACTIVE TEST

1. Select "EXTERNAL LAMPS" of IPDM E/R active test item.
2. With operating the test items, check that the parking lamp is turned ON.

**TAIL** : Parking lamp ON  
**Off** : Parking lamp OFF

##### Is the inspection result normal?

- YES >> Parking lamp circuit is normal.  
NO >> Refer to [EXL-97, "Diagnosis Procedure"](#).

### Diagnosis Procedure

INFOID:000000009010295

#### 1.CHECK PARKING LAMP FUSE

1. Turn ignition switch OFF.
2. Check that the following fuses are not fusing.

Unit	Location	Fuse No.	Capacity
Parking lamp	IPDM E/R	#46	10 A
		#47	

##### Is the inspection result normal?

- YES >> GO TO 3.  
NO >> GO TO 2.

#### 2.CHECK PARKING LAMP SHORT CIRCUIT

1. Disconnect the following connectors.
  - IPDM E/R
  - Front combination lamp
  - Rear combination lamp
  - License plate lamp
2. Check continuity between IPDM E/R harness connector and ground.

IPDM E/R		Ground	Continuity
Connector	Terminal		
RH	E14		Not existed
LH			
		43	

##### Is the inspection result normal?

- YES >> Replace fuse. (Replace IPDM E/R if fusing is found again.)  
NO >> Repair or replace harness. And then replace the fuse.

#### 3.CHECK PARKING LAMP BULB

Check applicable lamp bulb.

##### Is the inspection result normal?

- YES >> GO TO 4.  
NO >> Replace bulb.

#### 4.CHECK PARKING LAMP OUTPUT VOLTAGE

##### CONSULT ACTIVE TEST

1. Disconnect front combination lamp connector.
2. Turn ignition switch ON.

# PARKING LAMP CIRCUIT

**[XENON TYPE]**

**< DTC/CIRCUIT DIAGNOSIS >**

3. Select "EXTERNAL LAMPS" of IPDM E/R active test item.
4. With operating the test items, check voltage between IPDM E/R harness connector and ground.

(+)		(-)	Test item	Voltage (Approx.)	
IPDM E/R					
Connector	Terminal				
RH	E14	37	EXTERNAL LAMPS	TAIL	Battery voltage
				Off	0 V
LH	43	TAIL		Battery voltage	
		Off		0 V	

Is the inspection result normal?

- YES >> GO TO 5.  
 NO >> Replace IPDM E/R.

## 5. CHECK PARKING LAMP OPEN CIRCUIT

1. Turn ignition switch OFF.
2. Disconnect IPDM E/R connector.
3. Check continuity between IPDM E/R harness connector and front combination lamp harness connector.

IPDM E/R		Front combination lamp		Continuity
Connector	Terminal	Connector	Terminal	
RH	E14	37	E119	Existed
LH		43	E118	

Is the inspection result normal?

- YES >> GO TO 6.  
 NO >> Repair or replace harness.

## 6. CHECK PARKING LAMP GROUND OPEN CIRCUIT

Check continuity between front combination lamp harness connector and ground.

Front combination lamp		Ground	Continuity
Connector	Terminal		
RH	E119	3	Existed
LH	E118		

Is the inspection result normal?

- YES >> Check corresponding bulb socket and harness. Repair or replace if necessary.  
 NO >> Repair or replace harness.

# FRONT SIDE MARKER LAMP CIRCUIT

< DTC/CIRCUIT DIAGNOSIS >

[XENON TYPE]

## FRONT SIDE MARKER LAMP CIRCUIT

### Component Function Check

INFOID:000000009010296

#### 1. CHECK PARKING LAMP OPERATION

Check that the parking lamp is turned ON.

Is the inspection result normal?

YES >> GO TO 2.

NO >> Refer to [EXL-97, "Component Function Check"](#).

#### 2. CHECK FRONT SIDE MARKER LAMP OPERATION

##### Ⓜ CONSULT ACTIVE TEST

1. Select "EXTERNAL LAMPS" of IPDM E/R active test item.

2. With operating the lighting switch, check that the front side marker lamp is turned ON.

**TAIL : Front side marker lamp ON**

**Off : Front side marker lamp OFF**

Is the inspection result normal?

YES >> Front side marker lamp circuit is normal.

NO >> Refer to [EXL-99, "Diagnosis Procedure"](#).

### Diagnosis Procedure

INFOID:000000009010297

#### 1. CHECK FRONT SIDE MARKER LAMP BULB

Check the applicable lamp bulb.

Is the inspection result normal?

YES >> GO TO 2.

NO >> Replace bulb.

#### 2. CHECK FRONT SIDE MARKER LAMP OPEN CIRCUIT

1. Turn ignition switch OFF.

2. Disconnect IPDM E/R connector and front combination lamp connector.

3. Check continuity between IPDM E/R harness connector and front combination lamp harness connector.

IPDM E/R		Front combination lamp		Continuity
Connector	Terminal	Connector	Terminal	
LH	E14	43	E118	Existed
RH		37	E119	

Is the inspection result normal?

YES >> Check corresponding bulb socket and harness. Repair or replace if necessary.

NO >> Repair or replace harness.

A  
B  
C  
D  
E  
F  
G  
H  
I  
J  
K  
M  
N  
O  
P

EXL

# TURN SIGNAL LAMP CIRCUIT

< DTC/CIRCUIT DIAGNOSIS >

[XENON TYPE]

## TURN SIGNAL LAMP CIRCUIT

### Component Function Check

INFOID:000000009010298

#### 1. CHECK TURN SIGNAL LAMP

##### CONSULT ACTIVE TEST

1. Select "FLASHER" of BCM (FLASHER) active test item.
2. With operating the test items, check that the turn signal lamp is turned ON.

- LH** : Turn signal lamps (LH) ON
- RH** : Turn signal lamps (RH) ON
- Off** : Turn signal lamps OFF

Is the inspection result normal?

- YES >> Turn signal lamp circuit is normal.
- NO >> Refer to [EXL-100, "Diagnosis Procedure"](#).

### Diagnosis Procedure

INFOID:000000009010299

#### 1. CHECK TURN SIGNAL LAMP BULB

Check applicable lamp bulb.

Is the inspection result normal?

- YES >> GO TO 2.
- NO >> Replace bulb.

#### 2. CHECK TURN SIGNAL LAMP OUTPUT VOLTAGE

1. Turn ignition switch OFF.
2. Disconnect front combination lamp connector, door mirror connector and rear combination lamp connector.
3. Turn ignition switch ON.
4. With operating the turn signal switch, check voltage between BCM harness connector and ground.

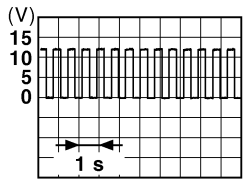
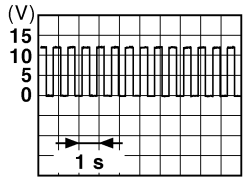
(+)		(-)	Condition	Voltage (Approx.)	
BCM					
Connector	Terminal				
M70	60	Ground	Turn signal switch	LH	 <p style="text-align: right; font-size: small;">PKID0926E</p>
			OFF	0 V	
	61		RH	 <p style="text-align: right; font-size: small;">PKID0926E</p>	
			OFF	0 V	

Is the inspection result normal?

- YES >> GO TO 3.
- NO >> GO TO 4.

# TURN SIGNAL LAMP CIRCUIT

[XENON TYPE]

< DTC/CIRCUIT DIAGNOSIS >

## 3. CHECK TURN SIGNAL LAMP OPEN CIRCUIT

1. Turn ignition switch OFF.
2. Disconnect BCM connector.
3. Check continuity between BCM harness connector and front combination lamp, door mirror or rear combination lamp harness connector.

Front turn signal lamp

BCM		Front combination lamp		Continuity
Connector	Terminal	Connector	Terminal	
LH	M70	60	E118	Existed
RH		61	E119	

Side turn signal lamp

BCM		Door mirror		Continuity
Connector	Terminal	Connector	Terminal	
Driver side	M70	60	D3	Existed
Passenger side		61	D23	

Rear turn signal lamp

BCM		Rear combination lamp		Continuity
Connector	Terminal	Connector	Terminal	
LH	M70	60	B60	Existed
RH		61	B232	

Is the inspection result normal?

YES >> GO TO 5.

NO >> Repair or replace harness.

## 4. CHECK TURN SIGNAL LAMP SHORT CIRCUIT

Check continuity between BCM harness connector and ground.

BCM		Ground	Continuity
Connector	Terminal		
M70	60		Not existed
	61		

Is the inspection result normal?

YES >> Check each bulb socket for internal short circuit. Replace BCM if check result is normal. Refer to [BCS-95. "Removal and Installation"](#).

NO >> Repair or replace harness.

## 5. CHECK TURN SIGNAL LAMP GROUND OPEN CIRCUIT

Check continuity between front combination lamp, door mirror or rear combination lamp and ground.

Front turn signal lamp

Front combination lamp		Ground	Continuity
Connector	Terminal		
LH	E118	3	Existed
RH	E119		

Side turn signal lamp

Door mirror		Ground	Continuity
Connector	Terminal		
Driver side	D3	19	Existed
Passenger side	D23		

# TURN SIGNAL LAMP CIRCUIT

< DTC/CIRCUIT DIAGNOSIS >

[XENON TYPE]

Rear turn signal lamp

Rear combination lamp		Terminal	Ground	Continuity
Connector				Existed
LH	B60	4		
RH	B232			

Is the inspection result normal?

- YES >> Check corresponding bulb socket and harness. Repair or replace if necessary.
- NO >> Repair or replace harness.

# OPTICAL SENSOR

< DTC/CIRCUIT DIAGNOSIS >

[XENON TYPE]

## OPTICAL SENSOR

### Component Function Check

INFOID:000000009010300

#### 1.CHECK OPTICAL SENSOR SIGNAL BY CONSULT

##### CONSULT DATA MONITOR

1. Turn ignition switch ON.
2. Select "OPTISEN (DTCT)" of BCM (HEADLAMP) data monitor item.
3. Turn lighting switch AUTO.
4. With the optical sensor illuminating, check the monitor status.

Monitor item	Condition		Voltage (Approx.)
OPTISEN (DTCT)	Optical sensor	When illuminating	3.1 V or more *
		When shutting off light	0.6 V or less

\*: Illuminates the optical sensor. The value may be less than the standard value if brightness is weak.

Is the inspection result normal?

- YES >> Optical sensor is normal.  
 NO >> Refer to [EXL-103. "Diagnosis Procedure"](#).

### Diagnosis Procedure

INFOID:000000009010301

#### 1.CHECK OPTICAL SENSOR POWER SUPPLY INPUT

1. Turn ignition switch ON.
2. Turn lighting switch AUTO.
3. Check voltage between optical sensor harness connector and ground.

(+)		(-)	Voltage (Approx.)
Optical sensor			
Connector	Terminal	Ground	5 V
M17	1		

Is the inspection result normal?

- YES >> GO TO 2.  
 NO >> GO TO 4.

#### 2.CHECK OPTICAL SENSOR GROUND INPUT

Check voltage between optical sensor harness connector and ground.

(+)		(-)	Voltage (Approx.)
Optical sensor			
Connector	Terminal	Ground	0 V
M17	3		

Is the inspection result normal?

- YES >> GO TO 3.  
 NO >> GO TO 6.

#### 3.CHECK OPTICAL SENSOR SIGNAL OUTPUT

With illuminating the optical sensor, check voltage between optical sensor harness connector and ground.

# OPTICAL SENSOR

[XENON TYPE]

< DTC/CIRCUIT DIAGNOSIS >

(+)		(-)	Condition	Voltage (Approx.)
Optical sensor				
Connector	Terminal			
M17	2	Ground	Optical sensor	When illuminating 3.1 V or more *
				When shutting off light 0.6 V or less

\*: Illuminate the optical sensor. The value may be less than the standard if brightness is weak.

Is the inspection result normal?

YES >> GO TO 7.

NO >> Replace the optical sensor.

## 4. CHECK OPTICAL SENSOR OPEN CIRCUIT

1. Turn ignition switch OFF.
2. Disconnect optical sensor connector and BCM connector.
3. Check continuity between optical sensor harness connector and BCM harness connector.

Optical sensor		BCM		Continuity
Connector	Terminal	Connector	Terminal	
M17	1	M68	17	Existed

Is the inspection result normal?

YES >> GO TO 5.

NO >> Repair or replace harness.

## 5. CHECK OPTICAL SENSOR SHORT CIRCUIT

Check continuity between optical sensor harness connector and ground.

Optical sensor		Ground	Continuity
Connector	Terminal		
M17	1		Not existed

Is the inspection result normal?

YES >> Replace BCM. Refer to [BCS-95. "Removal and Installation"](#).

NO >> Repair or replace harness.

## 6. CHECK OPTICAL SENSOR GROUND OPEN CIRCUIT

1. Turn ignition switch OFF.
2. Disconnect optical sensor connector and BCM connector.
3. Check continuity between optical sensor harness connector and BCM harness connector.

Optical sensor		BCM		Continuity
Connector	Terminal	Connector	Terminal	
M17	3	M68	18	Existed

Is the inspection result normal?

YES >> Replace BCM. Refer to [BCS-95. "Removal and Installation"](#).

NO >> Repair or replace harness.

## 7. CHECK OPTICAL SENSOR SIGNAL OPEN CIRCUIT

1. Turn ignition switch OFF.
2. Disconnect optical sensor connector and BCM connector.
3. Check continuity between optical sensor harness connector and BCM harness connector.



# OPTICAL SENSOR

< DTC/CIRCUIT DIAGNOSIS >

[XENON TYPE]

Optical sensor		BCM		Continuity
Connector	Terminal	Connector	Terminal	
M17	2	M68	14	Existed

Is the inspection result normal?

YES >> GO TO 8.

NO >> Repair or replace harness.

## 8.CHECK OPTICAL SENSOR SHORT CIRCUIT

Check continuity between optical sensor harness connector and ground.

Optical sensor		Ground	Continuity
Connector	Terminal		
M17	2		Not existed

Is the inspection result normal?

YES >> Replace BCM. Refer to [BCS-95, "Removal and Installation"](#).

NO >> Repair or replace harness.

A  
B  
C  
D  
E  
F  
G  
H  
I  
J  
K  
EXL  
M  
N  
O  
P

EXL

# HAZARD SWITCH

< DTC/CIRCUIT DIAGNOSIS >

[XENON TYPE]

## HAZARD SWITCH

### Component Function Check

INFOID:000000009010302

#### 1.CHECK HAZARD SWITCH SIGNAL BY CONSULT

##### CONSULT DATA MONITOR

1. Turn ignition switch ON.
2. Select "HAZARD SW" of BCM (FLASHER) data monitor item.
3. With operating the hazard switch, check the monitor status.

Monitor item	Condition		Monitor status
HAZARD SW	Hazard switch	ON	On
		OFF	Off

Is the inspection result normal?

- YES >> Hazard switch circuit is normal.  
 NO >> Refer to [EXL-106. "Diagnosis Procedure"](#).

### Diagnosis Procedure

INFOID:000000009010303

#### 1.CHECK HAZARD SWITCH SIGNAL INPUT

1. Turn ignition switch OFF.
2. Disconnect hazard switch connector.
3. Check voltage between hazard switch harness connector and ground.

(+)		(-)	Voltage (Approx.)
Hazard switch			
Connector	Terminal	Ground	12 V
M45	2		

Is the inspection result normal?

- YES >> GO TO 4.  
 NO >> GO TO 2.

#### 2.CHECK HAZARD SWITCH SIGNAL OPEN CIRCUIT

1. Disconnect BCM connector.
2. Check continuity between hazard switch harness connector and BCM harness connector.

Hazard switch		BCM		Continuity
Connector	Terminal	Connector	Terminal	
M45	2	M68	29	Existed

Is the inspection result normal?

- YES >> GO TO 3.  
 NO >> Repair or replace harness.

#### 3.CHECK HAZARD SWITCH SIGNAL SHORT CIRCUIT

Check continuity between hazard switch harness connector and ground.

Hazard switch		Ground	Continuity
Connector	Terminal		
M45	2		Not existed

Is the inspection result normal?

- YES >> Replace BCM. Refer to [BCS-95. "Removal and Installation"](#).  
 NO >> Repair or replace harness.

# HAZARD SWITCH

< DTC/CIRCUIT DIAGNOSIS >

[XENON TYPE]

## 4.CHECK HAZARD SWITCH GROUND OPEN CIRCUIT

Check continuity between hazard switch harness connector and ground.

Hazard switch		Ground	Continuity
Connector	Terminal		
M45	1		Existed

Is the inspection result normal?

- YES >> Replace hazard switch.
- NO >> Repair or replace harness.

A  
B  
C  
D  
E  
F  
G  
H  
I  
J  
K  
M  
N  
O  
P

EXL

# TAIL LAMP CIRCUIT

< DTC/CIRCUIT DIAGNOSIS >

[XENON TYPE]

## TAIL LAMP CIRCUIT

### BODY SIDE

#### BODY SIDE : Component Function Check

INFOID:000000009010304

### 1.CHECK TAIL LAMP OPERATION

#### ⓐCONSULT ACTIVE TEST

1. Select "EXTERNAL LAMPS" of IPDM E/R active test item.
2. With operating the test items, check that the tail lamp is turned ON.

**TAIL : Tail Lamp ON**

**Off : Tail lamp OFF**

#### Is the inspection result normal?

YES >> Tail lamp circuit is normal.

NO >> Refer to [EXL-108. "BODY SIDE : Diagnosis Procedure"](#).

#### BODY SIDE : Diagnosis Procedure

INFOID:000000009010305

### 1.CHECK TAIL LAMP FUSE

1. Turn ignition switch OFF.
2. Check that the following fuses are not fusing.

Unit	Location	Fuse No.	Capacity
Tail lamp	IPDM E/R	#46	10 A
		#47	

#### Is the inspection result normal?

YES >> GO TO 2.

NO >> Repair the malfunctioning part before replacing the fuse.

### 2.CHECK TAIL LAMP OUTPUT VOLTAGE

#### ⓐCONSULT ACTIVE TEST

1. Disconnect rear combination lamp connector.
2. Turn ignition switch ON.
3. Select "EXTERNAL LAMPS" of IPDM E/R active test item.
4. With operating the test items, check voltage between IPDM E/R harness connector and ground.

(+)		(-)	Test item	Voltage (Approx.)	
IPDM E/R					
Connector	Terminal				
E14	38	Ground	EXTERNAL LAMPS	TAIL	Battery voltage
				Off	0 V
	44			TAIL	Battery voltage
				Off	0 V

#### Is the inspection result normal?

YES >> GO TO 3.

NO >> GO TO 4.

### 3.CHECK TAIL LAMP OPEN CIRCUIT

1. Turn ignition switch OFF.
2. Disconnect the following connectors.
  - IPDM E/R
  - Front combination lamp
  - Rear combination lamp

# TAIL LAMP CIRCUIT

[XENON TYPE]

## < DTC/CIRCUIT DIAGNOSIS >

- Tail lamp (back door side)
- License plate lamp
- 3. Check continuity between IPDM E/R harness connector and rear combination lamp harness connector.

IPDM E/R		Rear combination lamp		Continuity
Connector	Terminal	Connector	Terminal	
RH	E14	38	B232	Existed
LH		44	B60	

Is the inspection result normal?

- YES >> GO TO 5.
- NO >> Repair or replace harness.

### 4.CHECK TAIL LAMP SHORT CIRCUIT

1. Turn ignition switch OFF.
2. Disconnect the following connectors.
  - IPDM E/R
  - Front combination lamp
  - Rear combination lamp
  - Tail lamp (back door side)
  - License plate lamp
3. Check continuity between IPDM E/R harness connector and ground.

IPDM E/R		Ground	Continuity
Connector	Terminal		
RH	E14	38	Not existed
LH		44	

Is the inspection result normal?

- YES >> Replace IPDM E/R.
- NO >> Repair or replace harness.

### 5.CHECK TAIL LAMP GROUND OPEN CIRCUIT

Check continuity between rear combination lamp harness connector and ground.

Rear combination lamp		Ground	Continuity
Connector	Terminal		
RH	B232	4	Existed
LH	B60		

Is the inspection result normal?

- YES >> Replace rear combination lamp.
- NO >> Repair or replace harness.

## BACK DOOR SIDE

### BACK DOOR SIDE : Component Function Check

INFOID:000000009010306

#### 1.CHECK TAIL LAMP (BODY SIDE) OPERATION

Check that the tail lamp (body side) is turned ON.

Is the inspection result normal?

- YES >> GO TO 2.
- NO >> Refer to [EXL-108. "BODY SIDE : Component Function Check"](#).

#### 2.CHECK TAIL LAMP (BACK DOOR SIDE) OPERATION

##### ⓂCONSULT ACTIVE TEST

1. Select "EXTERNAL LAMPS" of IPDM E/R active test item.
2. With operating the lighting switch, check that the tail lamp (back door side) is turned ON.

# TAIL LAMP CIRCUIT

[XENON TYPE]

< DTC/CIRCUIT DIAGNOSIS >

**TAIL : Tail lamp (back door side) ON**  
**Off : Tail lamp (back door side) OFF**

Is the inspection result normal?

YES >> Tail lamp (back door side) circuit is normal.  
NO >> Refer to [EXL-110, "BACK DOOR SIDE : Diagnosis Procedure"](#).

## BACK DOOR SIDE : Diagnosis Procedure

INFOID:000000009010307

### 1. CHECK TAIL LAMP (BACK DOOR SIDE) BULB

Check the applicable lamp bulb.

Is the inspection result normal?

YES >> GO TO 2.  
NO >> Replace bulb.

### 2. CHECK TAIL LAMP (BACK DOOR SIDE) OPEN CIRCUIT

1. Turn ignition switch OFF.
2. Disconnect IPDM E/R connector and tail lamp (back door side) connector.
3. Check continuity between IPDM E/R harness connector and tail lamp (back door side) harness connector.

IPDM E/R		Tail lamp (back door side)		Continuity
Connector	Terminal	Connector	Terminal	
LH	E14	D169	1	Existed
RH		D117		

Is the inspection result normal?

YES >> GO TO 3.  
NO >> Repair or replace harness.

### 3. CHECK TAIL LAMP (BACK DOOR SIDE) GROUND OPEN CIRCUIT

Check continuity between tail lamp (back door side) harness connector and ground.

Tail lamp (back door side)		Ground	Continuity
Connector	Terminal		
LH	D169	2	Existed
RH	D117		

Is the inspection result normal?

YES >> Check corresponding bulb socket and harness. Repair or replace if necessary.  
NO >> Repair or replace harness.

# LICENSE PLATE LAMP CIRCUIT

< DTC/CIRCUIT DIAGNOSIS >

[XENON TYPE]

## LICENSE PLATE LAMP CIRCUIT

### Component Function Check

INFOID:000000009010308

#### 1. CHECK TAIL LAMP OPERATION

Check that the tail lamp is turned ON.

Is the inspection result normal?

YES >> GO TO 2.

NO >> Refer to [EXL-108, "BODY SIDE : Component Function Check"](#).

#### 2. CHECK LICENSE PLATE LAMP OPERATION

##### Ⓜ CONSULT ACTIVE TEST

1. Select "EXTERNAL LAMPS" of IPDM E/R active test item.

2. With operating the lighting switch, check that the license plate lamp is turned ON.

**TAIL : License plate lamp ON**

**Off : License plate lamp OFF**

Is the inspection result normal?

YES >> License plate lamp circuit is normal.

NO >> Refer to [EXL-111, "Diagnosis Procedure"](#).

### Diagnosis Procedure

INFOID:000000009010309

#### 1. CHECK LICENSE PLATE LAMP BULB

Check the applicable lamp bulb.

Is the inspection result normal?

YES >> GO TO 2.

NO >> Replace bulb.

#### 2. CHECK LICENSE PLATE LAMP OPEN CIRCUIT

1. Turn ignition switch OFF.

2. Disconnect IPDM E/R connector and license plate lamp connector.

3. Check continuity between IPDM E/R harness connector and license plate lamp harness connector.

IPDM E/R		License plate lamp		Continuity
Connector	Terminal	Connector	Terminal	
LH	E14	D167	1	Existed
RH		D168		

Is the inspection result normal?

YES >> GO TO 3.

NO >> Repair or replace harness.

#### 3. CHECK LICENSE PLATE LAMP GROUND OPEN CIRCUIT

Check continuity between license plate lamp harness connector and ground.

License plate lamp		Ground	Continuity
Connector	Terminal		
LH	D167	2	Existed
RH	D168		

Is the inspection result normal?

YES >> Check corresponding bulb socket and harness. Repair or replace if necessary.

NO >> Repair or replace harness.

# EXTERIOR LIGHTING SYSTEM SYMPTOMS

< SYMPTOM DIAGNOSIS >

[XENON TYPE]

## SYMPTOM DIAGNOSIS

### EXTERIOR LIGHTING SYSTEM SYMPTOMS

#### Symptom Table

INFOID:000000009010310

**NOTE:**

Perform the self-diagnosis with CONSULT before the symptom diagnosis. Perform the trouble diagnosis if any DTC is detected.

Symptom		Possible cause	Inspection item
Headlamp does not switch to the high beam.	One side	<ul style="list-style-type: none"> <li>Fuse</li> <li>Harness between IPDM E/R and the front combination lamp</li> <li>Front combination lamp (High beam solenoid)</li> <li>IPDM E/R</li> <li>Harness between the front combination lamp and ground</li> </ul>	Headlamp (HI) circuit Refer to <a href="#">EXL-87, "Component Function Check"</a> .
	Both sides	<b>Symptom diagnosis</b> "BOTH SIDE HEADLAMPS DO NOT SWITCH TO HIGH BEAM" Refer to <a href="#">EXL-116, "Diagnosis Procedure"</a> .	
High beam indicator lamp is not turned ON. [Headlamp (HI) is turned ON.]		Combination meter	<ul style="list-style-type: none"> <li>Combination meter Data monitor "HI-BEAM IND"</li> <li>BCM (HEAD LAMP) Active test "HEADLAMP"</li> </ul>
Headlamp does not switch to the low beam.	One side	Front combination lamp (High beam solenoid)	—
	Both sides	<ul style="list-style-type: none"> <li>Combination switch</li> <li>Harness between the combination switch and BCM</li> <li>BCM</li> </ul>	Combination switch Refer to <a href="#">BCS-93, "Symptom Table"</a> .
		High beam request signal <ul style="list-style-type: none"> <li>BCM</li> <li>IPDM E/R</li> </ul>	IPDM E/R Data monitor "HL HI REQ"
		IPDM E/R	—
Headlamp is not turned ON.	One side	<ul style="list-style-type: none"> <li>Fuse</li> <li>Xenon bulb</li> <li>Harness between IPDM E/R and the front combination lamp</li> <li>Front combination lamp (xenon headlamp)</li> <li>IPDM E/R</li> <li>Harness between the front combination lamp and ground</li> </ul>	Headlamp (LO) circuit Refer to <a href="#">EXL-89, "Component Function Check"</a> .
	Both sides	<b>Symptom diagnosis</b> "BOTH SIDE HEADLAMPS (LO) ARE NOT TURNED ON" Refer to <a href="#">EXL-117, "Diagnosis Procedure"</a> .	
Headlamp is not turned OFF.	When the ignition switch is turned ON		
	The ignition switch is turned OFF (After activating the battery saver).	IPDM E/R	—



# EXTERIOR LIGHTING SYSTEM SYMPTOMS

< SYMPTOM DIAGNOSIS >

[XENON TYPE]

Symptom		Possible cause	Inspection item
Each lamp is not turned ON/OFF with lighting switch AUTO.		<ul style="list-style-type: none"> <li>• Combination switch</li> <li>• Harness between combination switch and BCM</li> <li>• BCM</li> </ul>	Combination switch Refer to <a href="#">BCS-93, "Symptom Table"</a> .
		<ul style="list-style-type: none"> <li>• Optical sensor</li> <li>• Harness between optical sensor and BCM</li> <li>• BCM</li> </ul>	Optical sensor Refer to <a href="#">EXL-103, "Component Function Check"</a> .
Front fog lamp is not turned ON.	One side	<ul style="list-style-type: none"> <li>• Front fog lamp bulb</li> <li>• Harness between IPDM E/R and front fog lamp</li> <li>• Front fog lamp</li> <li>• IPDM E/R</li> </ul>	Front fog lamp circuit Refer to <a href="#">EXL-95, "Component Function Check"</a> .
	Both sides	<b>Symptom diagnosis</b> "BOTH SIDE FRONT FOG LAMPS ARE NOT TURNED ON" Refer to <a href="#">EXL-119, "Diagnosis Procedure"</a> .	
Parking lamp is not turned ON.		<ul style="list-style-type: none"> <li>• Parking lamp bulb</li> <li>• Harness between IPDM E/R and front combination lamp</li> <li>• Front combination lamp</li> <li>• IPDM E/R</li> </ul>	Parking lamp circuit Refer to <a href="#">EXL-97, "Component Function Check"</a> .
Front side marker lamp is not turned ON.		<ul style="list-style-type: none"> <li>• Front side marker lamp bulb</li> <li>• Harness between IPDM E/R and front combination lamp</li> <li>• Front combination lamp</li> <li>• IPDM E/R</li> </ul>	Front side marker lamp circuit Refer to <a href="#">EXL-99, "Component Function Check"</a> .
Tail lamp or rear side marker lamp is not turned ON.	Body side	<ul style="list-style-type: none"> <li>• Harness between IPDM E/R and rear combination lamp</li> <li>• Rear combination lamp</li> </ul>	Tail lamp circuit (body side) Refer to <a href="#">EXL-108, "BODY SIDE : Component Function Check"</a> .
	Back door side	<ul style="list-style-type: none"> <li>• Harness between IPDM E/R and tail lamp (back door side)</li> <li>• Tail lamp (back door side)</li> </ul>	Tail lamp circuit (back door side) Refer to <a href="#">EXL-109, "BACK DOOR SIDE : Component Function Check"</a> .
License plate lamp is not turned ON.		<ul style="list-style-type: none"> <li>• License plate lamp bulb</li> <li>• Harness between IPDM E/R and license plate lamp</li> <li>• License plate lamp</li> </ul>	License plate lamp circuit Refer to <a href="#">EXL-111, "Component Function Check"</a> .
Tail lamp, rear side marker lamp and license plate lamp are not turned ON.		<ul style="list-style-type: none"> <li>• Fuse</li> <li>• Harness between IPDM E/R and rear combination lamp (LH)</li> <li>• IPDM E/R</li> </ul>	Tail lamp circuit (body side) Refer to <a href="#">EXL-108, "BODY SIDE : Component Function Check"</a> .
<ul style="list-style-type: none"> <li>• Parking lamp, side marker lamp, tail lamp and license plate lamp are not turned ON.</li> <li>• Parking lamp, side marker lamp, tail lamp and license plate lamp are not turned OFF.</li> </ul> (Each illumination is turned ON/OFF.)		<b>Symptom diagnosis</b> "PARKING, LICENSE PLATE, SIDE MARKER LAMP AND TAIL LAMPS ARE NOT TURNED ON" Refer to <a href="#">EXL-118, "Diagnosis Procedure"</a> .	
Position lamp indicator lamp is not turned ON. (Parking, side marker lamp and tail lamps are turned ON.)		Combination meter	<ul style="list-style-type: none"> <li>• Combination meter</li> <li>• Data monitor "LIGHT IND"</li> <li>• BCM (HEAD LAMP)</li> <li>• Active test "TAIL LAMP"</li> </ul>
Turn signal lamp does not blink.	Indicator lamp is normal. (Applicable side performs the high flasher activation.)	<ul style="list-style-type: none"> <li>• Harness between BCM and each turn signal lamp</li> <li>• Turn signal lamp bulb</li> </ul>	Turn signal lamp circuit Refer to <a href="#">EXL-100, "Component Function Check"</a> .
	Indicator lamp is included.	<ul style="list-style-type: none"> <li>• Combination switch</li> <li>• Harness between combination switch and BCM</li> <li>• BCM</li> </ul>	Combination switch Refer to <a href="#">BCS-93, "Symptom Table"</a> .

A  
B  
C  
D  
E  
F  
G  
H  
I  
J  
K  
EXL  
M  
N  
O  
P

# EXTERIOR LIGHTING SYSTEM SYMPTOMS

< SYMPTOM DIAGNOSIS >

[XENON TYPE]

Symptom	Possible cause	Inspection item	
Turn signal indicator lamp does not blink. (Turn signal i lamp is normal.)	One side	Combination meter —	
	Both sides (Always)	<ul style="list-style-type: none"> <li>• Turn signal indicator lamp signal</li> <li>- BCM</li> <li>• Combination meter</li> </ul>	<ul style="list-style-type: none"> <li>• Combination meter</li> <li>Data monitor "TURN IND"</li> <li>• BCM (FLASHER)</li> <li>Active test "FLASHER"</li> </ul>
	Both sides (Only when activating hazard warning lamp with the ignition switch OFF)	<ul style="list-style-type: none"> <li>• Combination meter power supply and ground circuit</li> <li>• Combination meter</li> </ul>	Combination meter Power supply and ground circuit Refer to <a href="#">MWI-66, "COMBINATION METER : Diagnosis Procedure"</a> .
<ul style="list-style-type: none"> <li>• Hazard warning lamp does not activate.</li> <li>• Hazard warning lamp continues activating.</li> </ul> (Turn signal is normal.)	<ul style="list-style-type: none"> <li>• Hazard switch</li> <li>• Harness between hazard switch and BCM</li> <li>• BCM</li> </ul>	Hazard switch Refer to <a href="#">EXL-106, "Component Function Check"</a> .	
Headlamp auto aiming does not activate. (AFS is normal.)	<ul style="list-style-type: none"> <li>• Harness between AFS control unit and headlamp aiming motor</li> <li>• Front combination lamp (Headlamp aiming motor)</li> <li>• AFS control unit</li> </ul>	Headlamp levelizer circuit Refer to <a href="#">EXL-92, "Component Function Check"</a> .	
AFS OFF indicator lamp is not turned ON.	<ul style="list-style-type: none"> <li>• AFS OFF indicator lamp signal</li> <li>- Combination meter</li> <li>- AFS control unit</li> <li>• Combination meter</li> </ul>	Combination meter Data monitor "AFS OFF IND"	

# NORMAL OPERATING CONDITION

< SYMPTOM DIAGNOSIS >

[XENON TYPE]

## NORMAL OPERATING CONDITION

### Description

INFOID:000000009010311

#### XENON HEADLAMP

- Brightness and the color of light may change slightly immediately after turning the headlamp ON until the xenon bulb becomes stable. This is normal.
- Illumination time lag may occur between right and left. This is normal.

#### AUTO LIGHT SYSTEM

The headlamp may not be turned ON/OFF immediately after passing dark area or bright area (short tunnel, sky bridge, shadowed area etc.) while using the auto light system. This causes for the control difference. This is normal.

A  
B  
C  
D  
E  
F  
G  
H  
I  
J  
K  
EXL  
M  
N  
O  
P

EXL

# BOTH SIDE HEADLAMPS DO NOT SWITCH TO HIGH BEAM

< SYMPTOM DIAGNOSIS >

[XENON TYPE]

## BOTH SIDE HEADLAMPS DO NOT SWITCH TO HIGH BEAM

### Description

INFOID:000000009010312

Both side headlamps (HI) are not turned ON when setting to the lighting switch HI or PASS.

### Diagnosis Procedure

INFOID:000000009010313

#### 1.COMBINATION SWITCH INSPECTION

Check combination switch. Refer to [BCS-93, "Symptom Table"](#).

Is the inspection result normal?

YES >> GO TO 2.

NO >> Repair or replace the malfunctioning part.

#### 2.CHECK HEADLAMP (HI) REQUEST SIGNAL INPUT

##### ⓂCONSULT DATA MONITOR

1. Select "HL HI REQ" of IPDM E/R data monitor item.
2. With operating the lighting switch, check the monitor status.

Monitor item	Condition		Monitor status
HL HI REQ	Lighting switch (2ND)	HI or PASS	On
		LO	Off

Is the inspection result normal?

YES >> GO TO 3.

NO >> Replace BCM. Refer to [BCS-95, "Removal and Installation"](#).

#### 3.HEADLAMP (HI) CIRCUIT INSPECTION

Check headlamp (HI) circuit. Refer to [EXL-87, "Component Function Check"](#).

Is the inspection result normal?

YES >> Replace IPDM E/R.

NO >> Repair or replace the malfunctioning part.

# BOTH SIDE HEADLAMPS (LO) ARE NOT TURNED ON

< SYMPTOM DIAGNOSIS >

[XENON TYPE]

## BOTH SIDE HEADLAMPS (LO) ARE NOT TURNED ON

### Description

INFOID:000000009010314

Both side headlamps (LO) are not turned ON in any condition.

### Diagnosis Procedure

INFOID:000000009010315

#### 1. CHECK COMBINATION SWITCH

Check combination switch. Refer to [BCS-93, "Symptom Table"](#).

Is the inspection result normal?

YES >> GO TO 2.

NO >> Repair or replace the malfunctioning part.

#### 2. CHECK HEADLAMP (LO) REQUEST SIGNAL INPUT

 CONSULT DATA MONITOR

1. Select "HL LO REQ" of IPDM E/R data monitor item.

2. With operating the lighting switch, check the monitor status.

Monitor item	Condition		Monitor status
HL LO REQ	Lighting switch	2ND	On
		OFF	Off

Is the inspection result normal?

YES >> GO TO 3.

NO >> Replace BCM. Refer to [BCS-95, "Removal and Installation"](#).

#### 3. HEADLAMP (LO) CIRCUIT INSPECTION

Check headlamp (LO) circuit. Refer to [EXL-89, "Component Function Check"](#).

Is the inspection result normal?

YES >> Replace IPDM E/R.

NO >> Repair or replace the malfunctioning part.

A  
B  
C  
D  
E  
F  
G  
H  
I  
J  
K  
L  
M  
N  
O  
P

EXL

# PARKING, LICENSE PLATE, SIDE MARKER AND TAIL LAMPS ARE NOT TURNED ON

< SYMPTOM DIAGNOSIS >

[XENON TYPE]

## PARKING, LICENSE PLATE, SIDE MARKER AND TAIL LAMPS ARE NOT TURNED ON

### Description

INFOID:000000009010316

The parking, license plate, tail lamps and side marker are not turned ON in any condition.

### Diagnosis Procedure

INFOID:000000009010317

#### 1.CHECK FUSE

Check that the following fuse is fusing.

Location	Fuse No.	Capacity
IPDM E/R	#46	10 A
	#47	10 A

Is the inspection result normal?

YES >> GO TO 2.

NO >> Repair the applicable circuit. And then replace the fuse.

#### 2.COMBINATION SWITCH INSPECTION

Check combination switch. Refer to [BCS-93. "Symptom Table"](#).

Is the combination switch normal?

YES >> GO TO 3.

NO >> Repair or replace the malfunctioning part.

#### 3.CHECK TAIL LAMP RELAY REQUEST SIGNAL INPUT

##### ⓂCONSULT DATA MONITOR

1. Select "TAIL & CLR REQ" of IPDM E/R data monitor item.
2. With operating the lighting switch, check the monitor status.

Monitor item	Condition		Monitor status
TAIL & CLR REQ	Lighting switch	1ST	On
		OFF	Off

Is the inspection result normal?

YES >> Replace IPDM E/R.

NO >> Replace BCM. Refer to [BCS-95. "Removal and Installation"](#).

# BOTH SIDE FRONT FOG LAMPS ARE NOT TURNED ON

< SYMPTOM DIAGNOSIS >

[XENON TYPE]

## BOTH SIDE FRONT FOG LAMPS ARE NOT TURNED ON

### Description

INFOID:000000009010318

The front fog lamps are not turned ON in any condition.

### Diagnosis Procedure

INFOID:000000009010319

#### 1. CHECK FUSE

Check that the following fuse is fusing.

Unit	Location	Fuse No.	Capacity
Front fog lamp	IPDM E/R	#50	15 A

Is the inspection result normal?

YES >> GO TO 2.

NO >> Repair the applicable circuit. And then replace the fuse.

#### 2. COMBINATION SWITCH INSPECTION

Check combination switch. Refer to [BCS-93. "Symptom Table"](#).

Is the inspection result normal?

YES >> GO TO 3.

NO >> Repair or replace the malfunctioning part.

#### 3. CHECK FRONT FOG LAMP REQUEST SIGNAL INPUT

##### CONSULT DATA MONITOR

1. Select "FR FOG REQ" of IPDM E/R data monitor item.

2. With operating the front fog lamp switch, check the monitor status.

Monitor item	Condition	Monitor status	
FR FOG REQ	Front fog lamp switch (With lighting switch 1ST)	ON	On
		OFF	Off

Is the item status normal?

YES >> GO TO 4.

NO >> Replace BCM. Refer to [BCS-95. "Removal and Installation"](#).

#### 4. FRONT FOG LAMP CIRCUIT INSPECTION

Check the front fog lamp circuit. Refer to [EXL-95. "Component Function Check"](#).

Is the inspection result normal?

YES >> Replace IPDM E/R.

NO >> Repair or replace the malfunctioning part.

A  
B  
C  
D  
E  
F  
G  
H  
I  
J  
K  
EXL  
M  
N  
O  
P

# HEADLAMP AIMING ADJUSTMENT

< PERIODIC MAINTENANCE >

[XENON TYPE]

## PERIODIC MAINTENANCE

### HEADLAMP AIMING ADJUSTMENT

#### description

INFOID:000000009010320

#### preparation before adjusting

##### NOTE:

- for details, refer to the regulations in your own country.
- perform aiming if the vehicle front body has been repaired and/or the headlamp assembly has been replaced.

before performing aiming adjustment, check the following.

- adjust the tire pressure to the specification.
- fill with fuel, engine coolant and each oil.
- maintain the unloaded vehicle condition. (remove luggage from the passenger compartment and the luggage room.)

##### NOTE:

do not remove the temporary tire, jack and on-vehicle tool.

- wipe out dirt on the headlamp.

##### CAUTION:

**never use organic solvent (thinner, gasoline etc.)**

- ride alone on the driver seat.

#### aiming adjustment screw

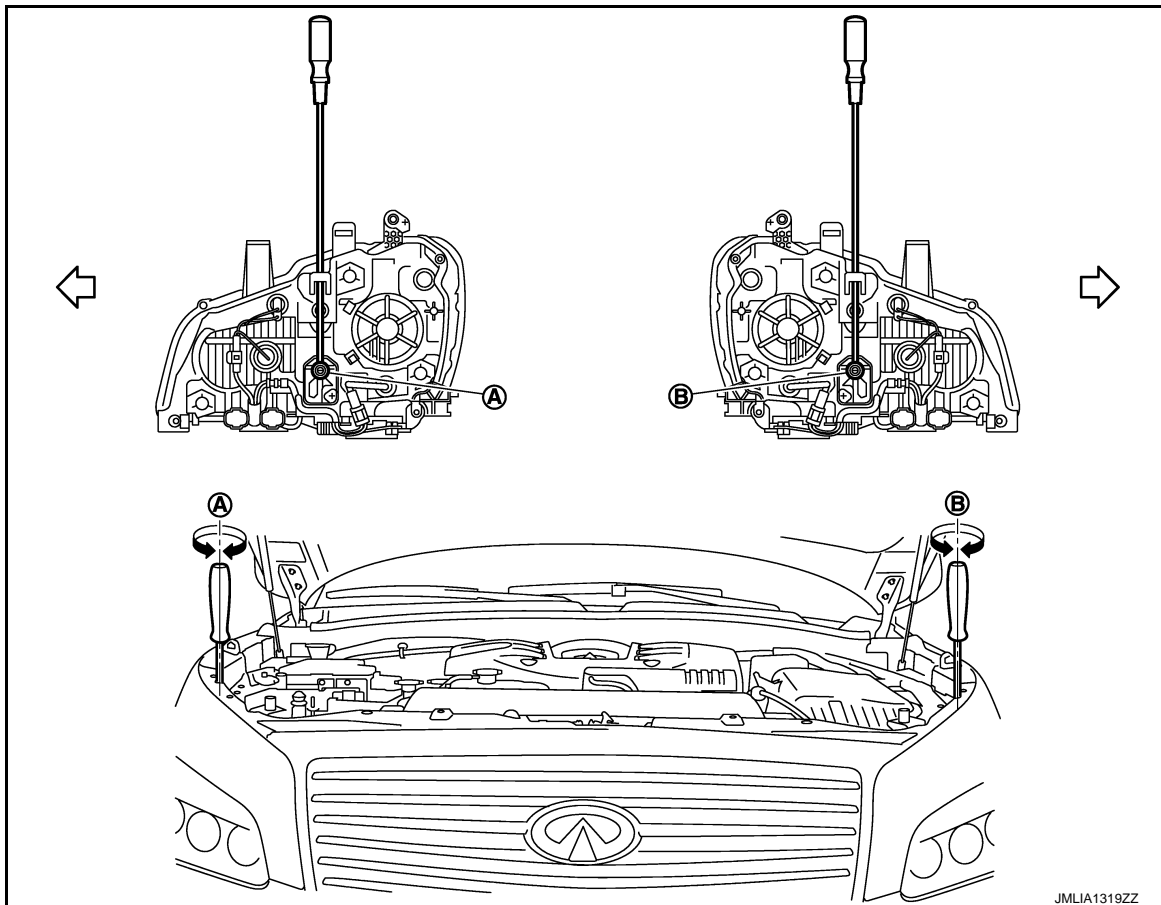

A. Headlamp RH HI/LO (UP/DOWN) adjustment screw

B. Headlamp LH HI/LO (UP/DOWN) adjustment screw

↔ Vehicle center



# HEADLAMP AIMING ADJUSTMENT

< PERIODIC MAINTENANCE >

[XENON TYPE]

	Adjustment screw	Screw driver rotation	Facing direction
A	Headlamp RH HI/LO (UP/DOWN)	Clockwise	UP
		Counterclockwise	DOWN
B	Headlamp LH HI/LO (UP/DOWN)	Clockwise	UP
		Counterclockwise	DOWN

## Aiming Adjustment Procedure

INFOID:000000009010321

1. Place the screen.
  - NOTE:**
  - Stop the vehicle facing the wall.
  - Place the board on a plain road vertically.
2. Face the vehicle with the screen. Maintain 10 m (32.8 ft) between the headlamp center and the screen.
3. Start the engine. Turn the headlamp (LO) ON.
  - NOTE:**
  - Shut off the headlamp light with the board to prevent from illuminating the adjustment screen.
  - CAUTION:**
  - Never cover the lens surface with a tape etc. The lens is made of resin.**
4. Measure the distance (X) between the horizontal center line of headlamp (H) and the cutoff line (A) within the light axis measurement range (R) from the vertical center line ahead of headlamp (V).

**Light axis measurement range (R) : 350 ± 175 mm (13.78 ± 6.89 in)**

Low beam distribution on the screen

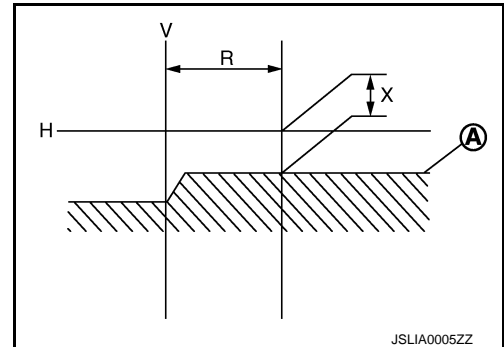

JSLIA0005ZZ

5. Adjust the cutoff line height (X) with the aiming adjustment screw so as to enter in the adjustment range (M–N) according to the horizontal center line of headlamp (H).

unit: mm (in)

Horizontal center line of headlamp (H)	Highest cutoff line height (M)	Lowest cutoff line height (N)
700 (27.56) or less	4 (0.16)	30 (1.18)
701(27.60) – 800 (31.50)	4 (0.16)	30 (1.18)
801 (31.54) or more	17 (0.67)	44 (1.73)

Side view

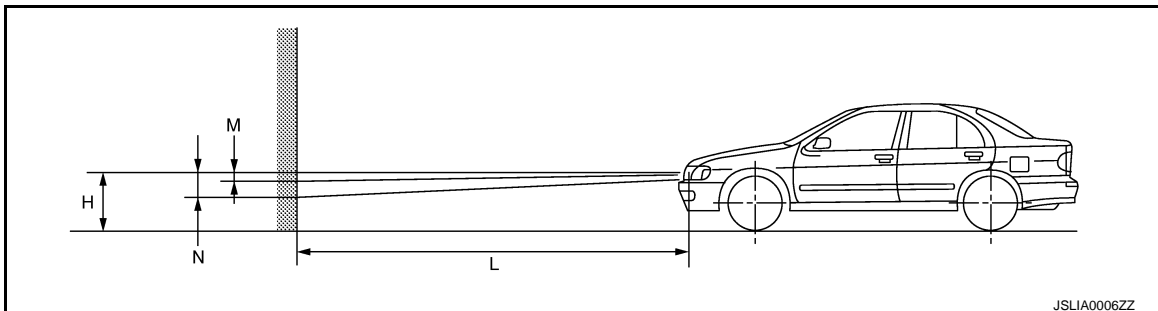

JSLIA0006ZZ

**Distance between the headlamp center and the screen (L) : 10 m (32.8 ft)**

# FRONT FOG LAMP AIMING ADJUSTMENT

< PERIODIC MAINTENANCE >

[XENON TYPE]

## FRONT FOG LAMP AIMING ADJUSTMENT

### Description

INFOID:000000009010322

### PREPARATION BEFORE ADJUSTING

#### NOTE:

- For details, refer to the regulations in your own country.
- Perform aiming if the vehicle front body has been repaired and/or the headlamp assembly has been replaced.

Before performing aiming adjustment, check the following.

- Adjust the tire pressure to the specification.
- Fill with fuel, engine coolant and each oil.
- Maintain the unloaded vehicle condition. (Remove luggage from the passenger compartment and the trunk room.)

#### NOTE:

Do not remove the temporary tire, jack and on-vehicle tool.

- Wipe out dirt on the headlamp.

#### CAUTION:

**Never use organic solvent (thinner, gasoline etc.)**

- Ride alone on the driver seat.

### AIMING ADJUSTMENT SCREW

- Turn the aiming adjusting screw for adjustment.

A: UP

B: DOWN

- For the position and direction of the adjusting screw, refer to the figure.

#### NOTE:

A screwdriver or hexagonal wrench [6 mm (0.24 in)] can be used for adjustment.

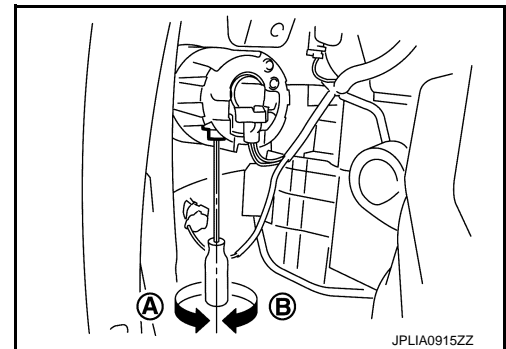

### Aiming Adjustment Procedure

INFOID:000000009010323

1. Place the screen.

#### NOTE:

- Stop the vehicle facing the wall.
- Place the board on a plain road vertically.

2. Face the vehicle with the screen. Maintain 10 m (32.8 ft) between the front fog lamp center and the screen.

3. Start the engine. Turn the front fog lamp ON.

#### NOTE:

Shut off the headlamp light with the board to prevent from illuminating the adjustment screen.

#### CAUTION:

**Never cover the lens surface with a tape etc. The lens is made of resin.**

4. Adjust the cutoff line height (A) with the aiming adjustment screw so that the distance (X) between the horizontal center line of front fog lamp (H) and (A) becomes 200 mm (7.87 in).

# FRONT FOG LAMP AIMING ADJUSTMENT

< PERIODIC MAINTENANCE >

[XENON TYPE]

Front fog lamp light distribution on the screen

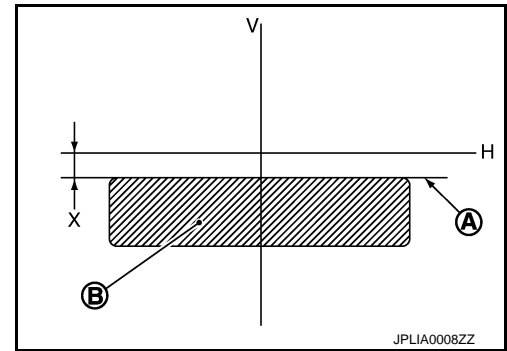

- A : Cutoff line
- B : High illuminance area
- H : Horizontal center line of front fog lamp
- V : Vertical center line of front fog lamp
- X : Cutoff line height

A  
B  
C  
D  
E  
F  
G  
H  
I  
J  
K  
L  
M  
N  
O  
P

EXL

# FRONT COMBINATION LAMP

< REMOVAL AND INSTALLATION >

[XENON TYPE]

## REMOVAL AND INSTALLATION

### FRONT COMBINATION LAMP

Exploded View

INFOID:000000009010324

#### REMOVAL

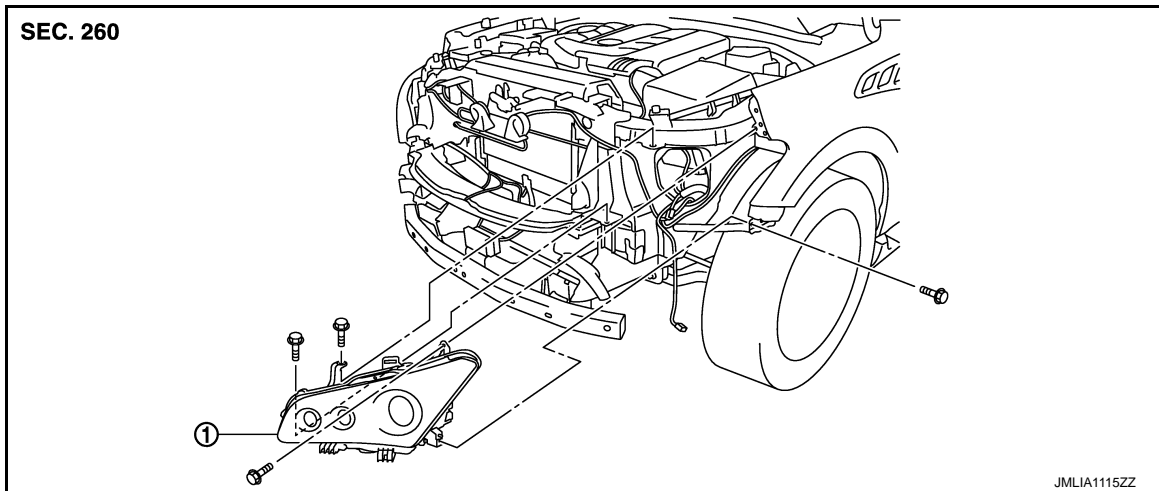

1. Front combination lamp

#### DISASSEMBLY

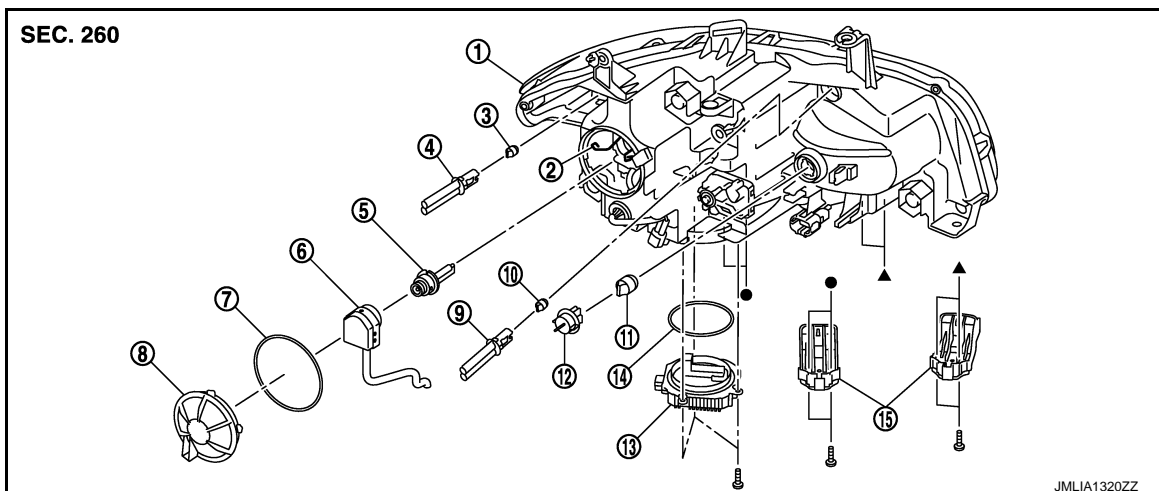

- |                              |                                 |  |
|------------------------------|---------------------------------|--|
| 1. Headlamp housing assembly | 2. Retaining spring             | 3. Xenon bulb                          |
| 4. Side marker lamp bulb     | 5. Side marker lamp bulb socket | 6. Xenon bulb socket                   |
| 7. Seal packing              | 8. Resin cap                    | 9. Parking lamp bulb socket            |
| 10. Parking lamp bulb        | 11. Front turn signal lamp bulb | 12. Front turn signal lamp bulb socket |
| 13. HID control unit         | 14. Seal packing                | 15. Bumper bracket                     |

Refer to [GI-4, "Components"](#) for symbols not described above.

**CAUTION:**  
HID control unit and xenon bulb socket cannot be disassembled.

#### Removal and Installation

INFOID:000000009010325

#### REMOVAL

**CAUTION:**

# FRONT COMBINATION LAMP

< REMOVAL AND INSTALLATION >

[XENON TYPE]

**Disconnect the battery negative terminal or remove the fuse.**

1. Remove front grille. Refer to [EXT-20, "Removal and Installation"](#).
2. Remove front bumper molding. Refer to [EXT-13, "Removal and Installation"](#).
3. Remove front bumper fascia. Refer to [EXT-13, "Removal and Installation"](#).
4. Remove headlamp mounting bolts.
5. Pull out headlamp assembly forward vehicle.
6. Disconnect connectors before removing headlamp assembly.

## INSTALLATION

Install in the reverse order of removal.

### NOTE:

After installation, perform aiming adjustment. Refer to [EXL-120, "description"](#).

## Replacement

INFOID:000000009010326

### CAUTION:

- **Disconnect the battery negative terminal or remove the fuse.**
- **After installing the bulb, install the resin cap and the bulb socket securely for watertightness.**
- **Never touch the glass of bulb directly by hand. Keep grease and other oily matters away from it. Never touch bulb by hand while it is lit or right after being turned off.**
- **Never leave bulb out of lamp reflector for a long time because dust, moisture smoke, etc. may affect the performance of lamp. When replacing bulb, be sure to replace it with new one.**

## HEADLAMP BULB (HI/LO)

1. Remove fender protector. Refer to [EXT-24, "FENDER PROTECTOR : Removal and Installation"](#).
2. Rotate resin cap counterclockwise and unlock it.
3. Rotate bulb socket counterclockwise and unlock it.
4. Remove retaining spring lock. And then remove bulb from headlamp housing assembly.

### CAUTION:

**Never break the xenon bulb ceramic tube when replacing the bulb.**

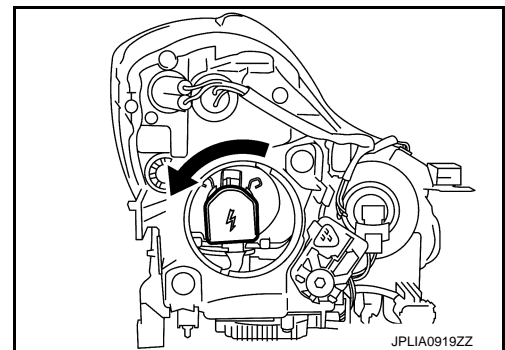

## PARKING LAMP BULB

1. Remove hood switch \*.  
\*:When replace a right.
2. Rotate bulb socket counterclockwise and unlock it.
3. Remove bulb from bulb socket.

## FRONT TURN SIGNAL LAMP BULB

1. Remove hood switch \*.  
\*:When replace a right.
2. Rotate bulb socket counterclockwise and unlock it.
3. Remove bulb from bulb socket.

## SIDE MARKER LAMP BULB

1. Remove fender protector. Refer to [EXT-24, "FENDER PROTECTOR : Removal and Installation"](#)
2. Rotate bulb socket counterclockwise and unlock it.
3. Remove bulb from bulb socket.

A  
B  
C  
D  
E  
F  
G  
H  
I  
J  
K  
EXL  
M  
N  
O  
P

# FRONT COMBINATION LAMP

< REMOVAL AND INSTALLATION >

[XENON TYPE]

## Disassembly and Assembly

INFOID:000000009010327

### DISASSEMBLY

1. Rotate resin cap counterclockwise and unlock it.
2. Rotate xenon bulb socket counterclockwise and unlock it.
3. Remove retaining spring lock. Remove xenon bulb.
4. Remove bumper bracket.
5. Rotate parking lamp bulb socket counterclockwise and unlock it.
6. Remove bulb from parking lamp bulb socket.
7. Rotate front turn signal lamp bulb socket counterclockwise and unlock it.
8. Remove bulb from front turn signal lamp bulb socket.
9. Rotate side marker lamp bulb socket counterclockwise and unlock it.
10. Remove bulb from bulb socket.

### ASSEMBLY

Assemble in the reverse order of disassembly.

#### **CAUTION:**

- **HID control unit and xenon bulb socket cannot be disassembled.**
- **After installing the bulb, install the resin cap and the bulb socket securely for watertightness.**

# FRONT FOG LAMP

< REMOVAL AND INSTALLATION >

[XENON TYPE]

## FRONT FOG LAMP

Exploded View

INFOID:000000009010328

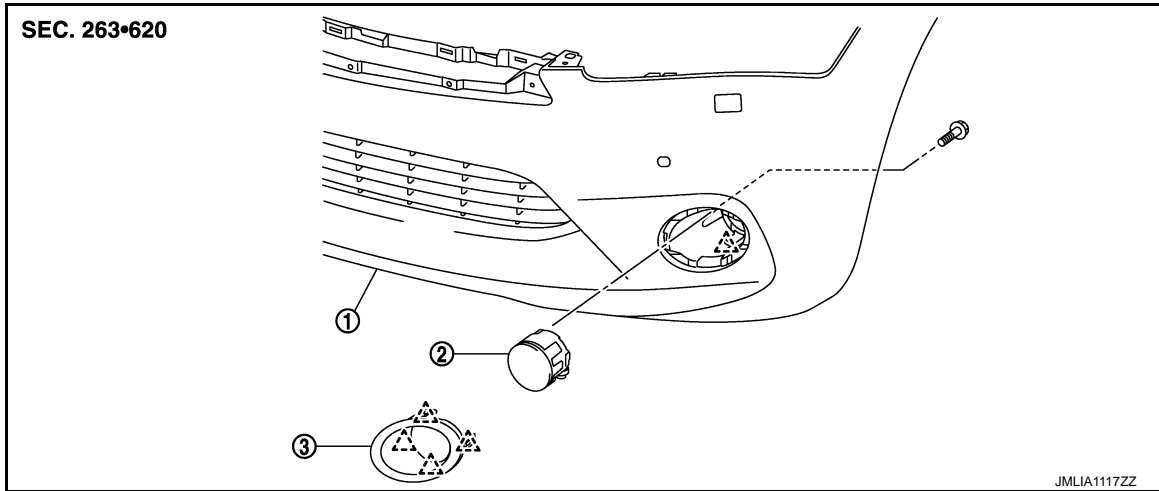

1. Front bumper

2. Front fog lamp

3. Front fog lamp finisher

△ : Pawl

## Removal and Installation

INFOID:000000009010329

### CAUTION:

Disconnect the battery negative terminal or remove the fuse.

### REMOVAL

1. Remove front fender protector. Refer to [EXT-24, "FENDER PROTECTOR : Removal and Installation"](#).
2. Remove front fog lamp finisher.
3. Disconnect front fog lamp harness connector.
4. Remove front fog lamp fixing screw.
5. Disengage pawl, and then remove front fog lamp.

### INSTALLATION

Install in the reverse order of removal.

### NOTE:

After installation, perform aiming adjustment. Refer to [EXL-122, "Description"](#).

## Replacement

INFOID:000000009010330

### CAUTION:

- Disconnect the battery negative terminal or remove the fuse.
- Never touch the glass of bulb directly by hand. Keep grease and other oily matters away from it. Never touch bulb by hand while it is lit or right after being turned off.
- Never leave bulb out of lamp reflector for a long time because dust, moisture smoke, etc. may affect the performance of lamp. When replacing bulb, be sure to replace it with new one.

## FRONT FOG LAMP BULB

1. Remove front fender protector. Keep the service area. Refer to [EXT-24, "FENDER PROTECTOR : Removal and Installation"](#).

## FRONT FOG LAMP

[XENON TYPE]

### < REMOVAL AND INSTALLATION >

2. Remove front fog lamp bulb connector (1).
3. Rotate bulb (2) counterclockwise and unlock it.

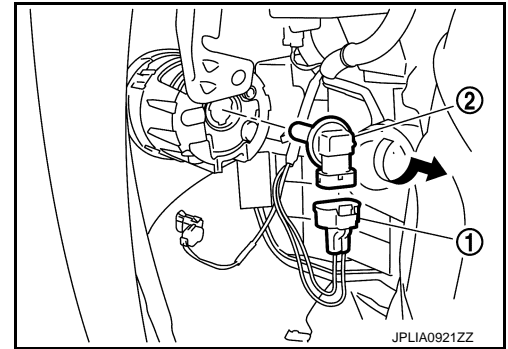



# SIDE TURN SIGNAL LAMP

< REMOVAL AND INSTALLATION >

[XENON TYPE]

## SIDE TURN SIGNAL LAMP

Exploded View

INFOID:000000009010331

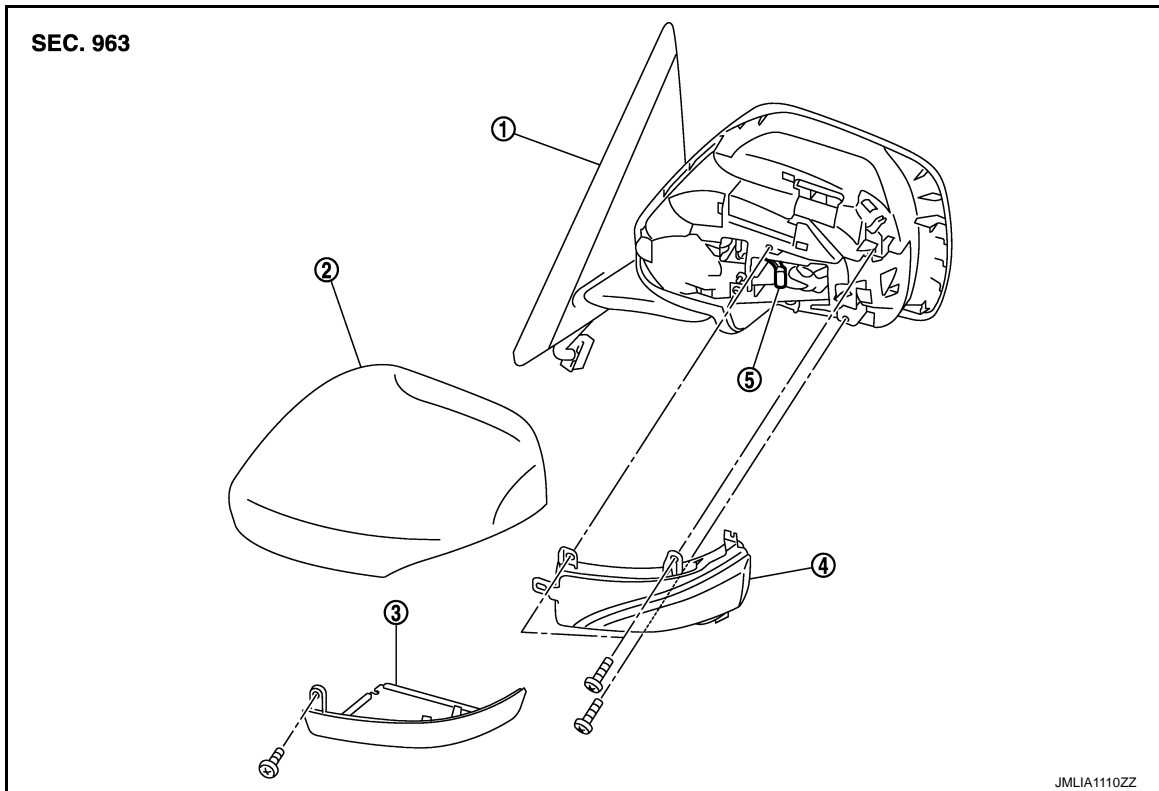

- |                                  |                               |                         |
|----------------------------------|-------------------------------|-------------------------|
| 1. Door mirror assembly          | 2. Door mirror cover          | 3. Side camera finisher |
| 4. Side turn signal lamp housing | 5. Side turn signal lamp bulb |                         |

## Removal and Installation

INFOID:000000009010332

**CAUTION:**  
Disconnect battery negative terminal or remove the fuse.

### REMOVAL

1. Remove the door mirror. Refer to [MIR-32. "DOOR MIRROR ASSEMBLY : Removal and Installation"](#).
2. Remove the glass mirror. Refer to [MIR-35. "GLASS MIRROR : Removal and Installation"](#).
3. Remove the side camera finisher. Refer to [MIR-33. "DOOR MIRROR ASSEMBLY : Disassembly and Assembly"](#).
4. Remove side turn signal lamp fixing screws (E), and then remove side turn signal lamp (with side turn signal lamp models only).

**NOTE:**

Pull slightly side camera finisher (1) covering side turn signal lamp bottom screw.

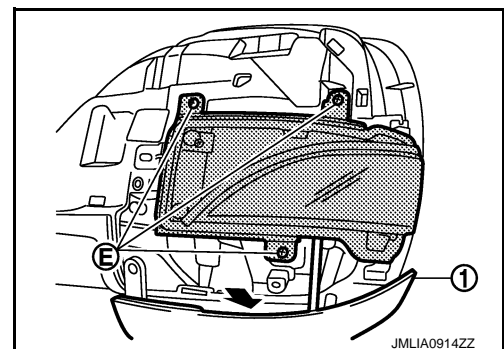

### INSTALLATION

Install in the reverse order of removal.

# OPTICAL SENSOR

< REMOVAL AND INSTALLATION >

[XENON TYPE]

## OPTICAL SENSOR

Exploded View

INFOID:000000009010333

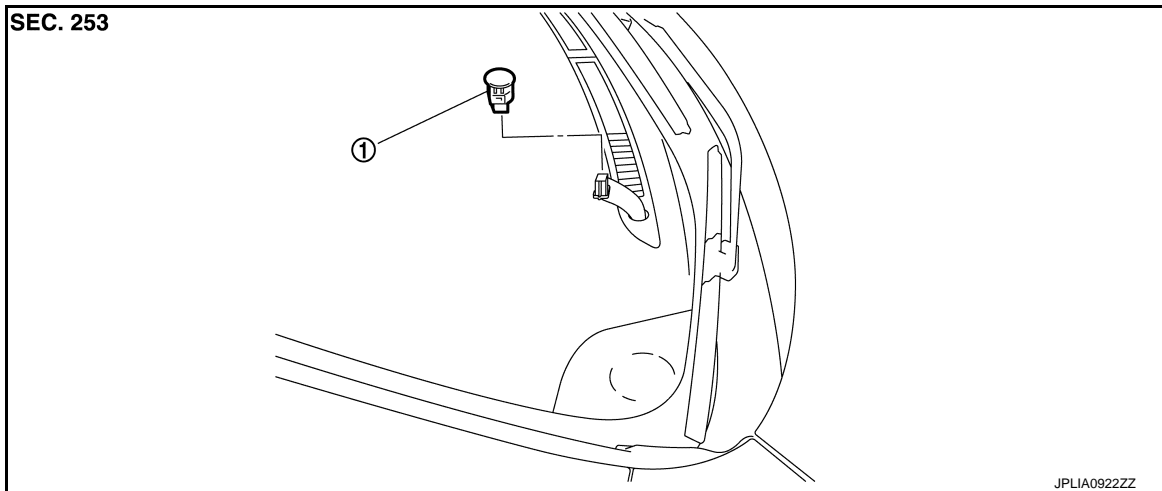

1. Optical sensor

## Removal and Installation

INFOID:000000009010334

### REMOVAL

1. Insert an appropriate tool between the optical sensor and the instrument upper panel. Pull out the optical sensor upward.
2. Disconnect optical sensor connector, and then remove optical sensor.

### INSTALLATION

Install in the reverse order of removal.

# LIGHTING & TURN SIGNAL SWITCH

< REMOVAL AND INSTALLATION >

[XENON TYPE]

## LIGHTING & TURN SIGNAL SWITCH

### Exploded View

INFOID:000000009010335

The lighting & turn signal switch is integrated in the combination switch. [BCS-96. "Removal and Installation"](#).

A  
B  
C  
D  
E  
F  
G  
H  
I  
J  
K  
EXL  
M  
N  
O  
P

## HAZARD SWITCH

< REMOVAL AND INSTALLATION >

[XENON TYPE]

---

### HAZARD SWITCH

#### Exploded View

INFOID:000000009010336

The hazard switch is integrated in the multifunction switch. Refer to [AV-297. "Removal and Installation"](#).

# AFS CONTROL UNIT

< REMOVAL AND INSTALLATION >

[XENON TYPE]

## AFS CONTROL UNIT

Exploded View

INFOID:000000009010337

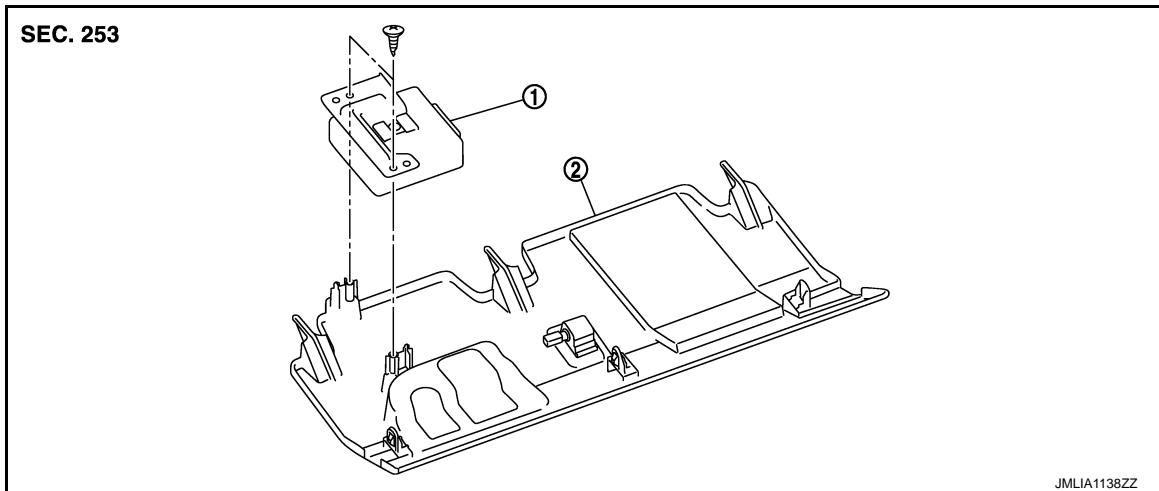

1. AFS control unit

2. Instrument lower cover

## Removal and Installation

INFOID:000000009010338

### REMOVAL

1. Remove instrument driver lower panel. Refer to [IP-14. "Removal and Installation"](#).
2. Remove AFS control unit mounting bolt.
3. Disconnect AFS control unit connector.
4. Remove AFS control unit.

### INSTALLATION

Install in the reverse order of removal.

A  
B  
C  
D  
E  
F  
G  
H  
I  
J  
K  
EXL  
M  
N  
O  
P

# HEIGHT SENSOR

< REMOVAL AND INSTALLATION >

[XENON TYPE]

## HEIGHT SENSOR

Exploded View

INFOID:000000009010339

### FRONT HEIGHT SENSOR

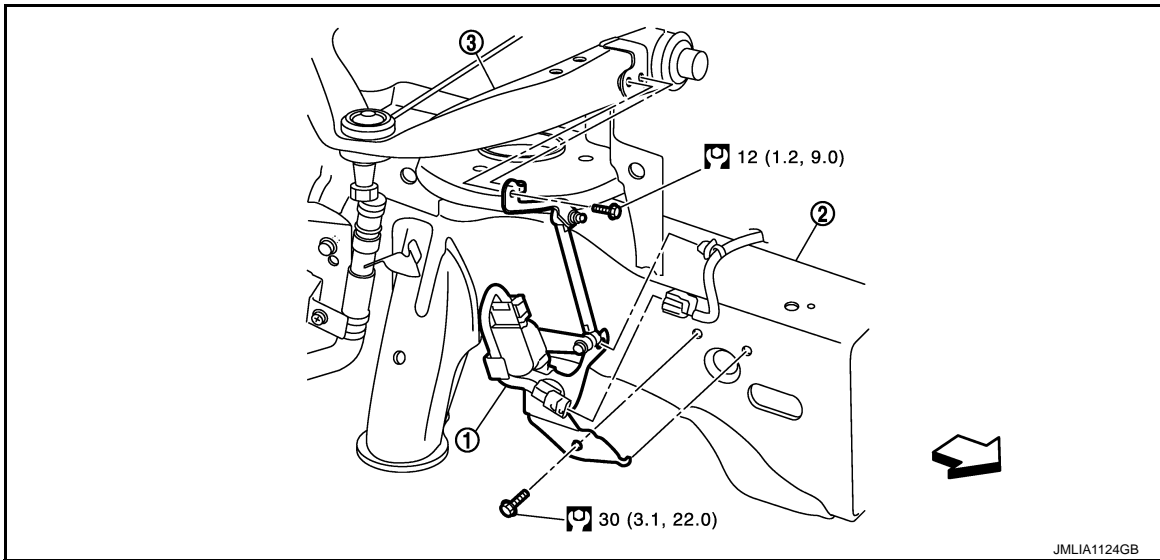

1. Front height sensor

2. Front member side RH

3. Front suspension upper link

↔ : Vehicle front

Refer to [GI-4. "Components"](#) for symbols in the figure.

### REAR HEIGHT SENSOR

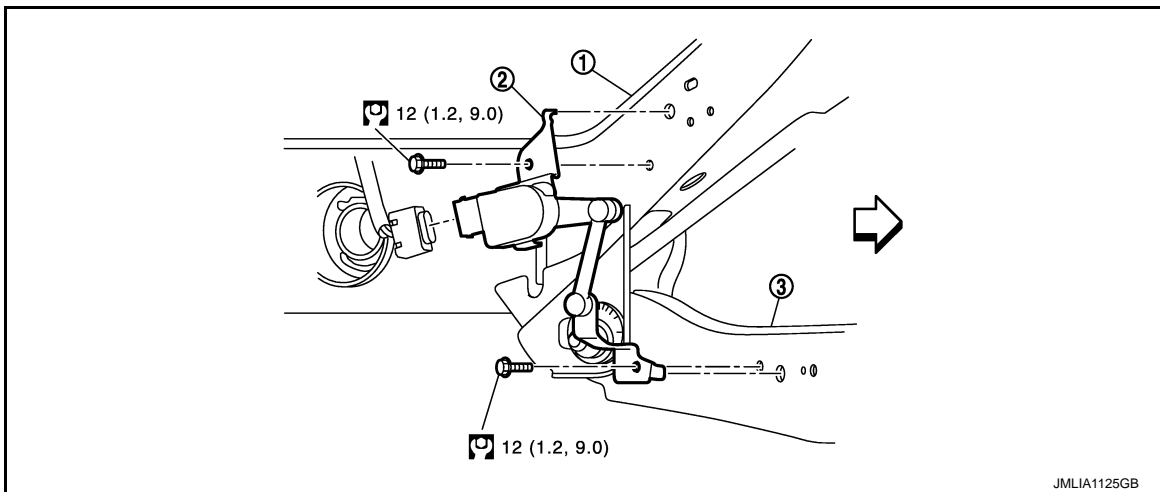

1. Rear suspension member

2. Rear height sensor

3. Rear suspension lower link

↔ : Vehicle front

Refer to [GI-4. "Components"](#) for symbols in the figure.

## Removal and Installation

INFOID:000000009010340

### REMOVAL

Front height sensor

1. Disconnect height sensor connector.
2. Remove height sensor mounting nuts.

# HEIGHT SENSOR

< REMOVAL AND INSTALLATION >

[XENON TYPE]

3. Remove height sensor.

Rear height sensor

1. Disconnect height sensor connector.
2. Remove height sensor mounting nuts.
3. Remove height sensor.

## INSTALLATION

Install in the reverse order of removal.

### **CAUTION:**

**Perform the levelizer adjustment when removing the height sensor. Refer to [EXL-63, "LEVELIZER ADJUSTMENT : Special Repair Requirement"](#).**

A  
B  
C  
D  
E  
F  
G  
H  
I  
J  
K  
EXL  
M  
N  
O  
P

# REAR COMBINATION LAMP

< REMOVAL AND INSTALLATION >

[XENON TYPE]

## REAR COMBINATION LAMP

Exploded View

INFOID:000000009010341

### REMOVAL

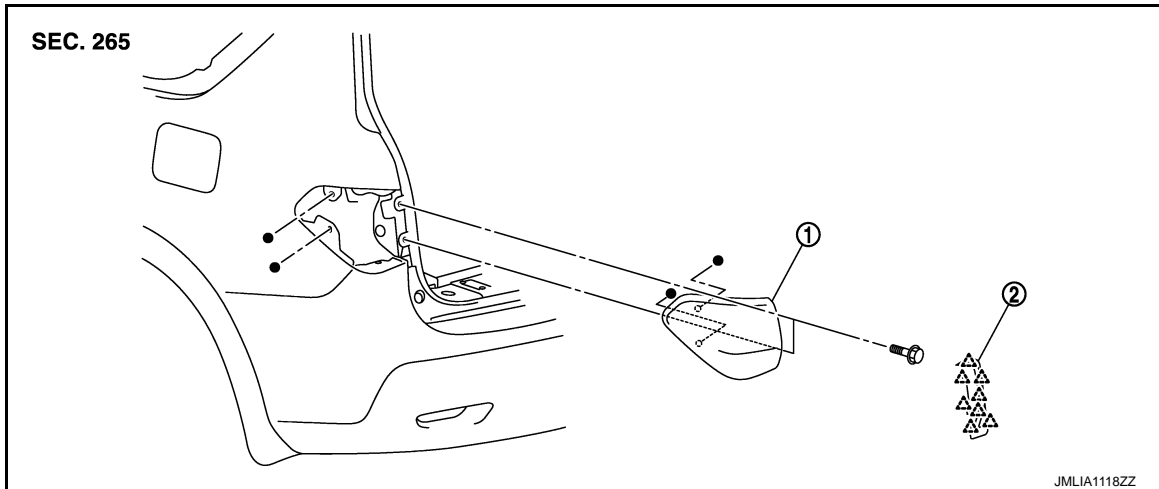

1. Rear combination lamp                      2. Rear combination lamp finisher

△ :Pawl

### DISASSEMBLY

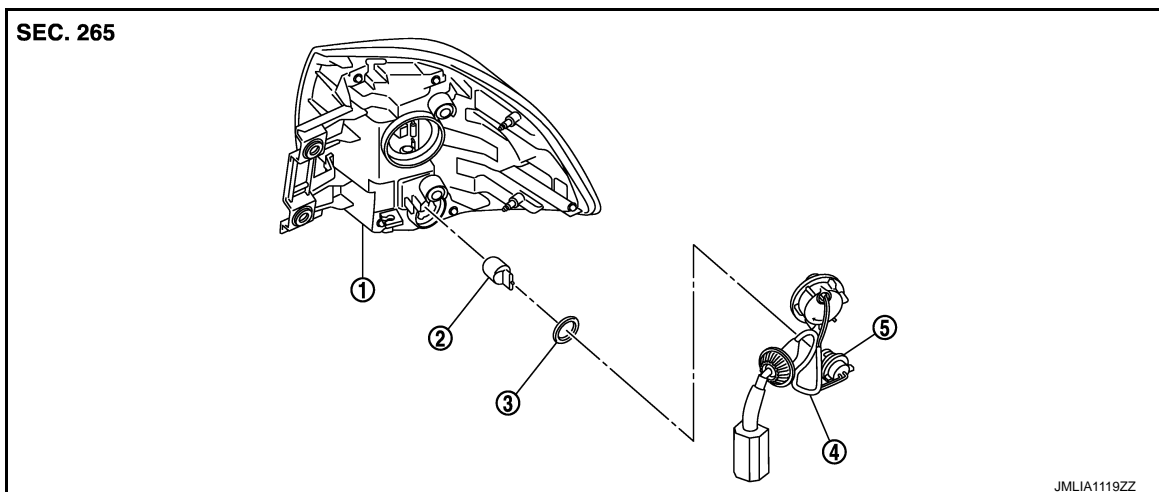

1. Rear combination lamp                      2. Rear turn signal bulb                      3. Seal packing  
4. Rear turn signal bulb socket              5. Rear combination lamp harness

### Removal and Installation

INFOID:000000009010342

**CAUTION:**  
Disconnect the battery negative terminal or remove the fuse.

### REMOVAL

1. Remove rear combination lamp finisher.
2. Remove rear combination lamp mounting bolts.
3. Pull rear combination lamp toward vehicle outside.
4. Disconnect rear combination lamp connector.
5. Remove rear combination lamp.



# REAR COMBINATION LAMP

< REMOVAL AND INSTALLATION >

[XENON TYPE]

## INSTALLATION

Install in the reverse order of removal.

A

B

C

D

E

F

G

H

I

J

K

**EXL**

M

N

O

P

# HIGH-MOUNTED STOP LAMP

< REMOVAL AND INSTALLATION >

[XENON TYPE]

## HIGH-MOUNTED STOP LAMP

Exploded View

INFOID:000000009010343

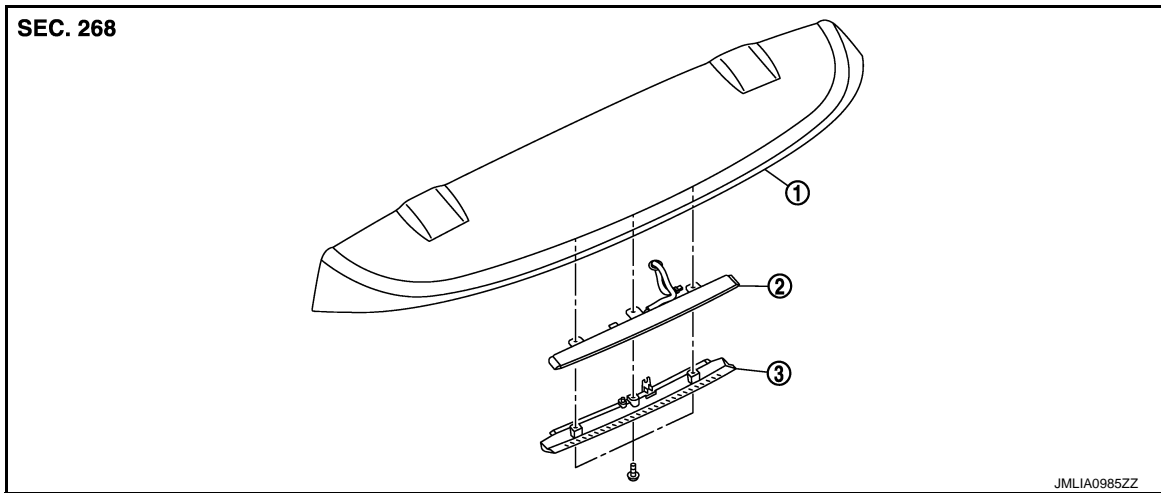

1. Rear spoiler

2. High-mounted stop lamp

3. High-mounted stop lamp cover

## Removal and Installation

INFOID:000000009010344

### REMOVAL

1. Remove rear spoiler. Refer to [EXT-42. "Removal and Installation"](#).
2. Remove high-mounted stop lamp mounting screws.
3. Remove high-mounted stop lamp cover, and then remove high-mounted stop lamp.

### INSTALLATION

Install in the reverse order of removal.

# BACK-UP LAMP

< REMOVAL AND INSTALLATION >

[XENON TYPE]

## BACK-UP LAMP

Exploded View

INFOID:000000009010345

### REMOVAL

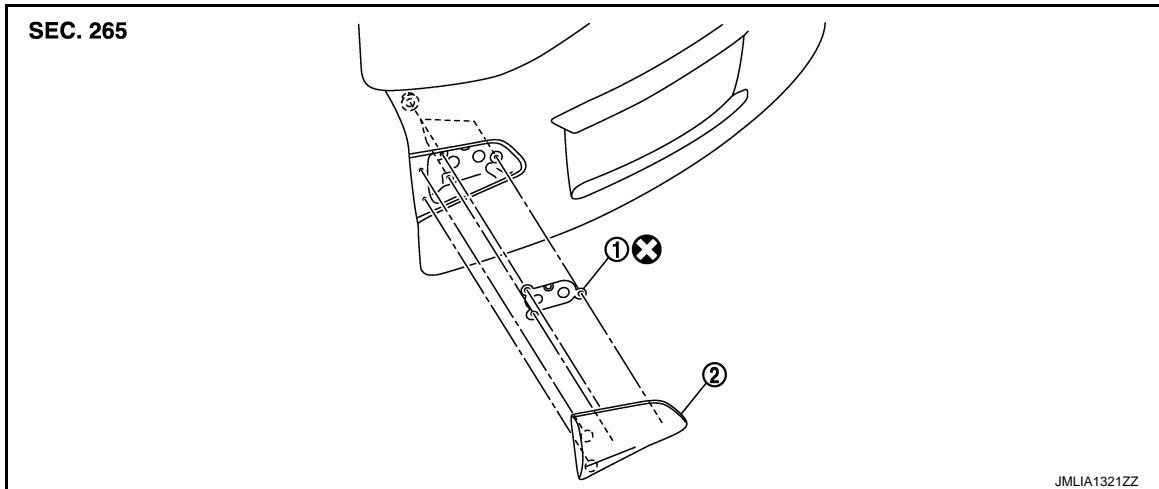

1. Seal packing
  2. Back-up lamp
- Refer to [GI-4, "Components"](#) for symbols not described above.

### DISASSEMBLY

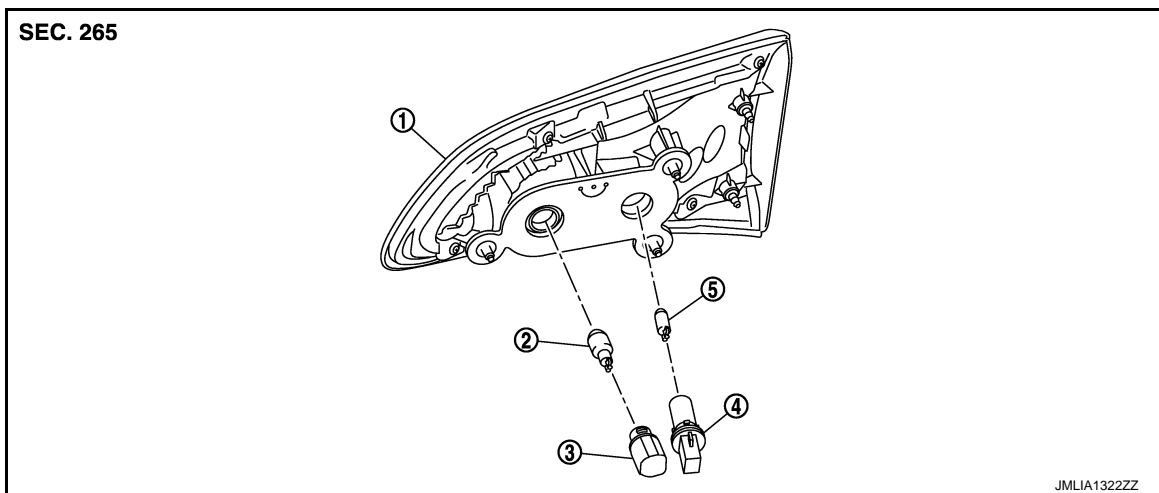

1. Back-up lamp
2. Back-up lamp bulb
3. Back-up lamp bulb socket
4. Tail lamp bulb socket
5. Tail lamp bulb

### Removal and Installation

INFOID:000000009010346

**CAUTION:**  
Disconnect the battery negative terminal or remove the fuse.

#### REMOVAL

1. Remove lamp mask. Refer to [INT-39, "Exploded View"](#).
2. Disconnect back-up lamp connector.
3. Remove back-up lamp mounting nuts, and then remove back-up lamp.

#### INSTALLATION

Install in the reverse order of removal.

A  
B  
C  
D  
E  
F  
G  
H  
I  
J  
K  
EXL  
M  
N  
O  
P

# BACK-UP LAMP

< REMOVAL AND INSTALLATION >

[XENON TYPE]

## Replacement

INFOID:000000009010347

### **CAUTION:**

- **Disconnect the battery negative terminal or remove the fuse.**
- **Never touch the glass of bulb directly by hand. Keep grease and other oily matters away from it. Never touch bulb by hand while it is lit or right after being turned off.**
- **Never leave bulb out of lamp reflector for a long time because dust, moisture smoke, etc. may affect the performance of lamp. When replacing bulb, be sure to replace it with new one.**

### TAIL LAMP BULB

1. Remove lamp mask. Refer to [INT-39, "Exploded View"](#).
2. Disconnect tail lamp connector.
3. Tail bulb socket counterclockwise and unlock it.
4. Remove bulb from bulb socket.

### BACK-UP LAMP BULB

1. Remove lamp mask. Refer to [INT-39, "Exploded View"](#).
2. Disconnect back-up lamp connector.
3. Turn bulb socket counterclockwise and unlock it.
4. Remove bulb from bulb socket.

# LICENSE PLATE LAMP

< REMOVAL AND INSTALLATION >

[XENON TYPE]

## LICENSE PLATE LAMP

### Exploded View

INFOID:000000009010348

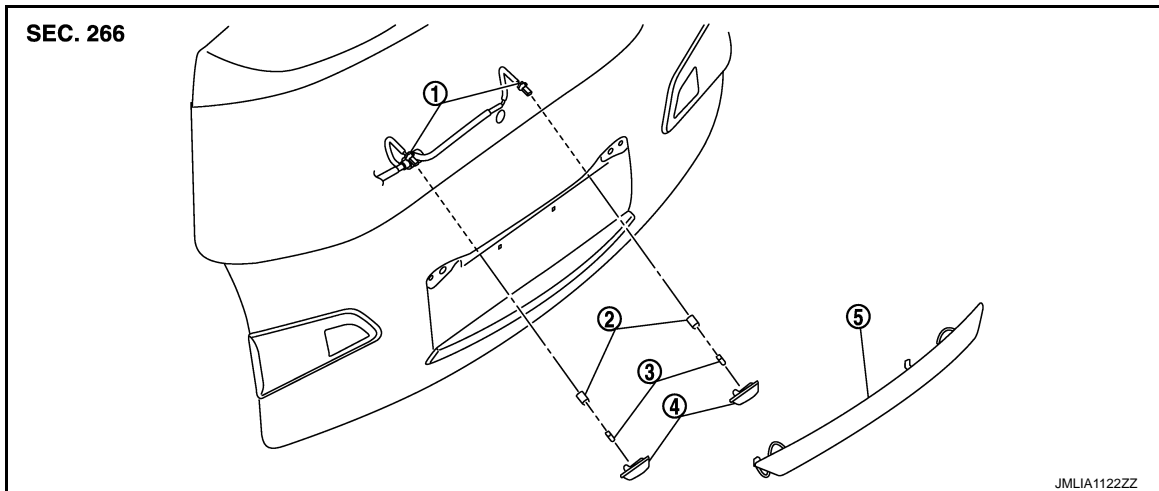

1. License plate lamp harness
2. License plate lamp bulb socket
3. License plate lamp bulb
4. License plate lamp
5. Back door finisher center upper

### Removal and Installation

INFOID:000000009010349

#### **CAUTION:**

**Disconnect the battery negative terminal or remove the fuse.**

#### REMOVAL

1. Remove back door trim. Refer to [INT-39, "Removal and Installation"](#).
2. Disconnect license plate lamp connector.
3. Remove back door finisher center upper.
4. Remove license plate lamp while pushing a resin clip, and then remove license plate lamp.

#### INSTALLATION

Install in the reverse order of removal.

### Replacement

INFOID:000000009010350

#### **CAUTION:**

- **Disconnect the battery negative terminal or remove the fuse.**
- **Never touch the glass of bulb directly by hand. Keep grease and other oily matters away from it. Never touch bulb by hand while it is lit or right after being turned off.**
- **Never leave bulb out of lamp reflector for a long time because dust, moisture smoke, etc. may affect the performance of lamp. When replacing bulb, be sure to replace it with new one.**

#### LICENSE PLATE LAMP BULB

1. Remove back door trim. Refer to [INT-39, "Removal and Installation"](#).
2. Disconnect license plate lamp connector.

## LICENSE PLATE LAMP

### < REMOVAL AND INSTALLATION >

[XENON TYPE]

3. Turn bulb socket (1) counterclockwise and unlock it.
4. Remove bulb (2) from socket.

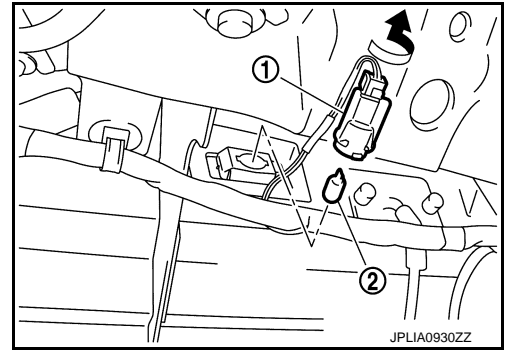

# SERVICE DATA AND SPECIFICATIONS (SDS)

< SERVICE DATA AND SPECIFICATIONS (SDS)

[XENON TYPE]

## SERVICE DATA AND SPECIFICATIONS (SDS)

### SERVICE DATA AND SPECIFICATIONS (SDS)

#### Bulb Specifications

INFOID:000000009010351

Item	Type	Wattage (W)	
Front combination lamp	Headlamp (HI/LO)	D2S (Xenon)	35
	Front turn signal lamp	WY21W (Amber)	21
	Parking lamp	W5W	5
Front fog lamp	H8	35	
Side turn signal lamp	Replace as an assembly because it cannot be disassembled.		
Rear combination lamp	Stop lamp/Tail lamp	LED	—
	Rear turn signal lamp	WY21W	21
Back-up lamp	W16W	16	
Tail lamp	W5W	5	
License plate lamp	W5W	5	
High-mounted stop lamp	LED	—	

A  
B  
C  
D  
E  
F  
G  
H  
I  
J  
K  
L  
M  
N  
O  
P

EXL