

# SECTION **STC**

## STEERING CONTROL SYSTEM

A  
B  
C  
D  
E  
F  
G  
H  
I  
J  
K  
L  
M  
N  
O  
P

### CONTENTS

<p><b>PRECAUTION</b> ..... 2</p> <p><b>PRECAUTIONS</b> ..... 2</p> <p style="padding-left: 20px;">Precaution for Supplemental Restraint System (SRS) "AIR BAG" and "SEAT BELT PRE-TENSIONER" .....2</p> <p style="padding-left: 20px;">Precautions for Removing of Battery Terminal .....2</p> <p><b>SYSTEM DESCRIPTION</b> ..... 3</p> <p><b>COMPONENT PARTS</b> ..... 3</p> <p style="padding-left: 20px;">Component Parts Location .....3</p> <p style="padding-left: 20px;">Component Description .....3</p> <p style="padding-left: 20px;">Power Steering Control Unit .....3</p> <p style="padding-left: 20px;">Power Steering Solenoid Valve .....4</p> <p><b>SYSTEM</b> ..... 5</p> <p><b>EPS SYSTEM</b> .....5</p> <p style="padding-left: 20px;">EPS SYSTEM : System Description .....5</p> <p style="padding-left: 20px;">EPS SYSTEM : Fail-Safe .....6</p> <p><b>ECU DIAGNOSIS INFORMATION</b> ..... 8</p> <p><b>POWER STEERING CONTROL UNIT</b> ..... 8</p> <p style="padding-left: 20px;">Reference Value .....8</p> <p style="padding-left: 20px;">Fail-Safe .....9</p> <p><b>WIRING DIAGRAM</b> .....10</p> <p><b>ELECTRONICALLY CONTROLLED POWER STEERING SYSTEM</b> .....10</p> <p style="padding-left: 20px;">Wiring Diagram ..... 10</p>	<p><b>BASIC INSPECTION</b> .....13</p> <p><b>DIAGNOSIS AND REPAIR WORK FLOW</b> .....13</p> <p style="padding-left: 20px;">Work Flow .....13</p> <p><b>DTC/CIRCUIT DIAGNOSIS</b> ..... 14</p> <p><b>POWER SUPPLY AND GROUND CIRCUIT</b> .... 14</p> <p style="padding-left: 20px;">Diagnosis Procedure .....14</p> <p><b>POWER STEERING SOLENOID VALVE</b> .....16</p> <p style="padding-left: 20px;">Component Function Check .....16</p> <p style="padding-left: 20px;">Diagnosis Procedure .....16</p> <p style="padding-left: 20px;">Component Inspection .....17</p> <p><b>ENGINE SPEED SIGNAL CIRCUIT</b> .....18</p> <p style="padding-left: 20px;">Diagnosis Procedure .....18</p> <p><b>VEHICLE SPEED SIGNAL CIRCUIT</b> .....20</p> <p style="padding-left: 20px;">Diagnosis Procedure .....20</p> <p><b>SYMPTOM DIAGNOSIS</b> .....22</p> <p><b>UNBALANCE STEERING WHEEL TURNING FORCE (TORQUE VARIATION)</b> .....22</p> <p style="padding-left: 20px;">Description .....22</p> <p style="padding-left: 20px;">Diagnosis Procedure .....22</p> <p><b>REMOVAL AND INSTALLATION</b> .....23</p> <p><b>POWER STEERING CONTROL UNIT</b> .....23</p> <p style="padding-left: 20px;">Removal and Installation .....23</p>
--	---

STC

# PRECAUTIONS

< PRECAUTION >

## PRECAUTION

### PRECAUTIONS

#### Precaution for Supplemental Restraint System (SRS) "AIR BAG" and "SEAT BELT PRE-TENSIONER"

INFOID:000000009012637

The Supplemental Restraint System such as "AIR BAG" and "SEAT BELT PRE-TENSIONER", used along with a front seat belt, helps to reduce the risk or severity of injury to the driver and front passenger for certain types of collision. Information necessary to service the system safely is included in the "SRS AIR BAG" and "SEAT BELT" of this Service Manual.

#### **WARNING:**

Always observe the following items for preventing accidental activation.

- To avoid rendering the SRS inoperative, which could increase the risk of personal injury or death in the event of a collision that would result in air bag inflation, all maintenance must be performed by an authorized NISSAN/INFINITI dealer.
- Improper maintenance, including incorrect removal and installation of the SRS, can lead to personal injury caused by unintentional activation of the system. For removal of Spiral Cable and Air Bag Module, see "SRS AIR BAG".
- Never use electrical test equipment on any circuit related to the SRS unless instructed to in this Service Manual. SRS wiring harnesses can be identified by yellow and/or orange harnesses or harness connectors.

#### PRECAUTIONS WHEN USING POWER TOOLS (AIR OR ELECTRIC) AND HAMMERS

#### **WARNING:**

Always observe the following items for preventing accidental activation.

- When working near the Air Bag Diagnosis Sensor Unit or other Air Bag System sensors with the ignition ON or engine running, never use air or electric power tools or strike near the sensor(s) with a hammer. Heavy vibration could activate the sensor(s) and deploy the air bag(s), possibly causing serious injury.
- When using air or electric power tools or hammers, always switch the ignition OFF, disconnect the battery, and wait at least 3 minutes before performing any service.

#### Precautions for Removing of Battery Terminal

INFOID:000000009863650

- When removing the 12V battery terminal, turn OFF the ignition switch and wait at least 30 seconds.

#### **NOTE:**

ECU may be active for several tens of seconds after the ignition switch is turned OFF. If the battery terminal is removed before ECU stops, then a DTC detection error or ECU data corruption may occur.

- For vehicles with the 2-batteries, be sure to connect the main battery and the sub battery before turning ON the ignition switch.

#### **NOTE:**

If the ignition switch is turned ON with any one of the terminals of main battery and sub battery disconnected, then DTC may be detected.

- After installing the 12V battery, always check "Self Diagnosis Result" of all ECUs and erase DTC.

#### **NOTE:**

The removal of 12V battery may cause a DTC detection error.

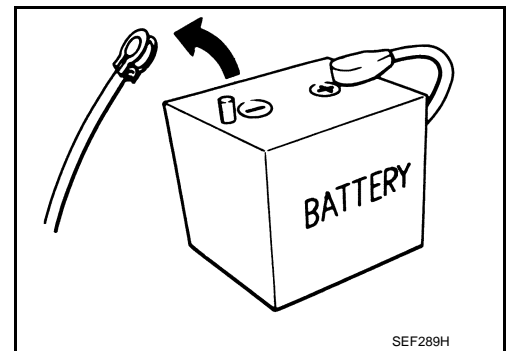

# COMPONENT PARTS

< SYSTEM DESCRIPTION >

## SYSTEM DESCRIPTION

### COMPONENT PARTS

#### Component Parts Location

INFOID:000000009012638

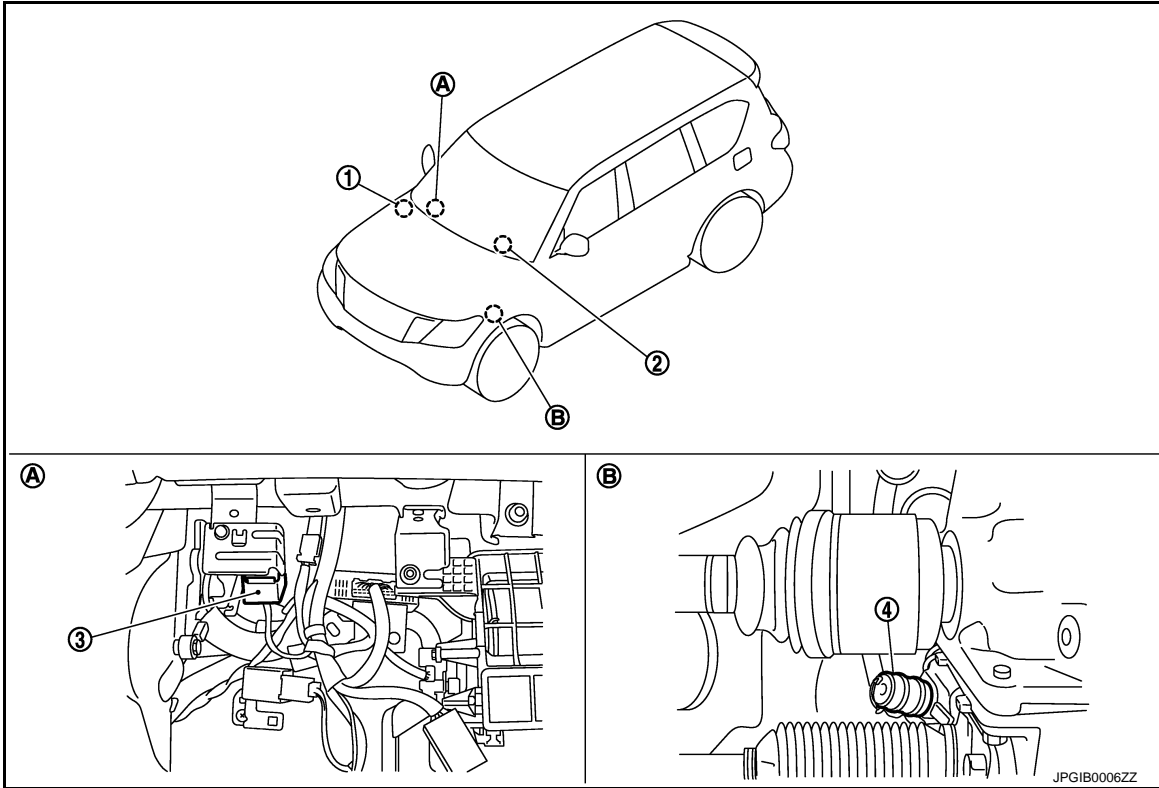

1. ECM  
Refer to [EC-23, "Component Parts Location"](#) (For USA and CANADA), [EC-593, "Component Parts Location"](#) (For MEXICO).
2. Combination meter  
Refer to [MWI-6, "METER SYSTEM: Component Parts Location"](#).
3. Power steering control unit
4. Power steering solenoid valve
- A. Glove box assembly removed
- B. Steering gear assembly

#### Component Description

INFOID:000000009012639

Component parts	Reference/Function
Power steering control unit	<a href="#">STC-3, "Power Steering Control Unit"</a>
Power steering solenoid valve	<a href="#">STC-4, "Power Steering Solenoid Valve"</a>
Combination meter	Transmits vehicle speed signal to power steering control unit.
ECM	Transmits engine speed signal to power steering control unit.

#### Power Steering Control Unit

INFOID:000000009012640

- Signals from various sensors control the driving voltage to the power steering solenoid valve.
- The power steering control unit controls the driving voltage to the power steering solenoid valve for maintaining the power steering assist force when the fail-safe function is activated. (The engine speed signals control EPS system if any vehicle speed signal error is detected.)

## COMPONENT PARTS

< SYSTEM DESCRIPTION >

---

### Power Steering Solenoid Valve

INFOID:000000009012641

Power steering solenoid valve controls the power steering oil pressure in the gear housing assembly.

# SYSTEM

< SYSTEM DESCRIPTION >

## SYSTEM

### EPS SYSTEM

#### EPS SYSTEM : System Description

INFOID:000000009012642

- The EPS system controls the power steering solenoid valve through the power steering control unit.
- The valve driving voltage to control the power steering solenoid valve varies according to the vehicle speed.

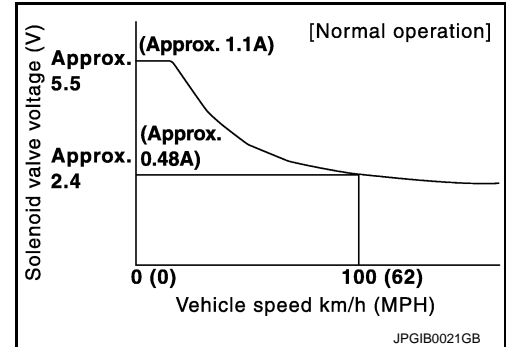

#### CONTROL DIAGRAM

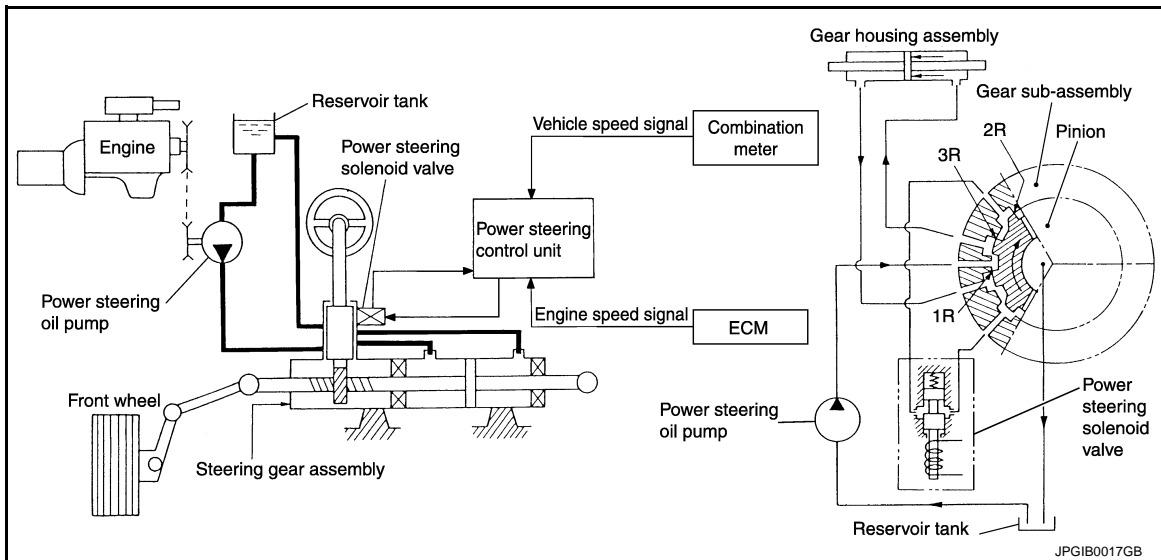

#### CROSS-SECTIONAL VIEW

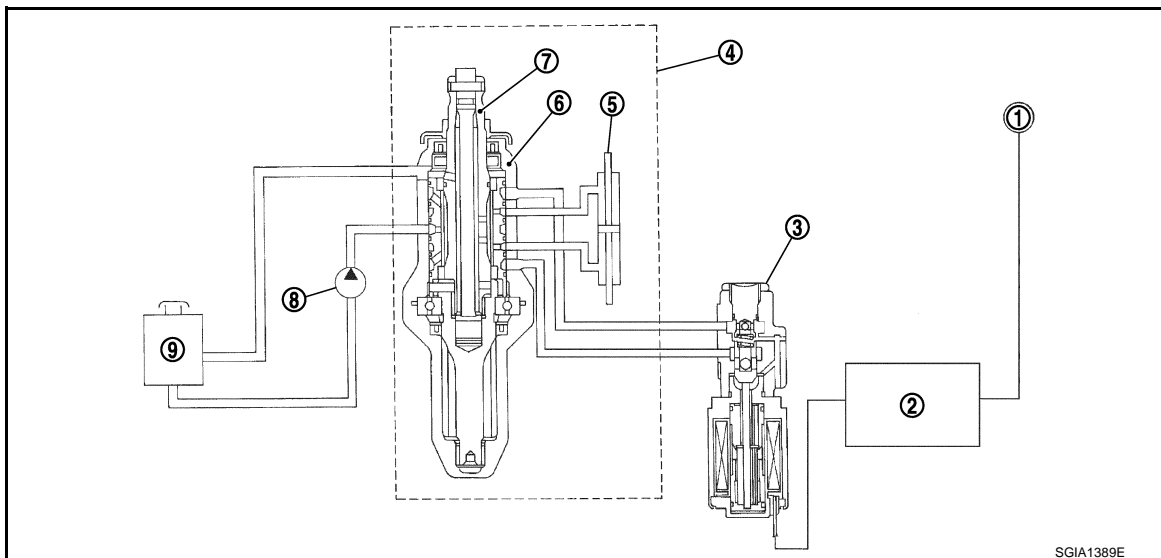

# SYSTEM

## < SYSTEM DESCRIPTION >

- |                           |                                |                                  |
|---------------------------|--------------------------------|----------------------------------|
| 1. Combination meter      | 2. Power steering control unit | 3. Power steering solenoid valve |
| 4. Steering gear assembly | 5. Gear housing assembly       | 6. Gear sub-assembly             |
| 7. Pinion                 | 8. Power steering oil pump     | 9. Reservoir tank                |

## OPERATION PRINCIPLE

During Parking (When Turning The Steering Wheel To The Right.)

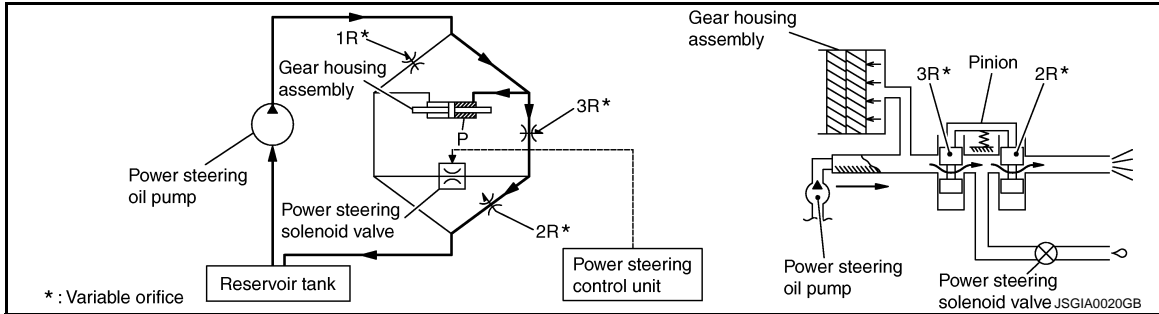

1. Power steering solenoid valve is closed while a vehicle is stopped.
2. Pinion "1R", "2R" and "3R" are closed depending on steering torque of steering wheel.
3. Oil pressure "P" in the gear housing assembly is the sum of oil pressures occurred in "2R" and "3R". This results in a light steering force because of high pressure.

During High-speed Operation

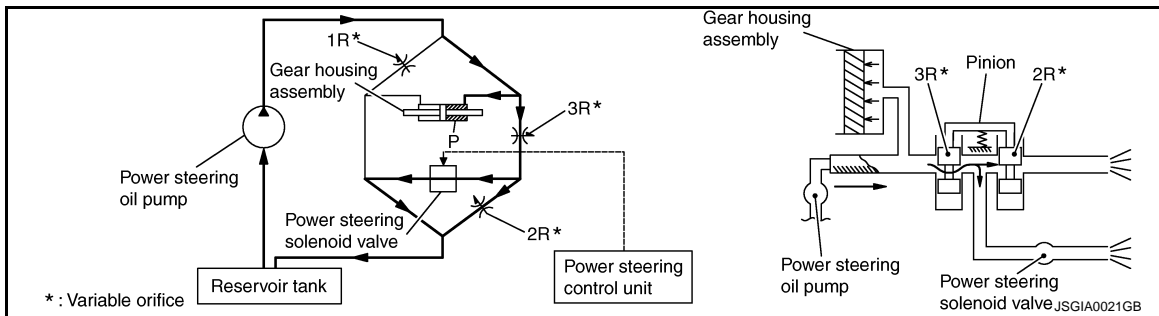

1. Power steering solenoid valve is opened during high-speed operation.
2. Pinion "1R", "2R" and "3R" are closed depending on steering torque of steering wheel.
3. Oil pressure "2R" does not occur because the power steering solenoid valve is on full throttle.
4. Oil pressure "P" in the gear housing assembly includes only oil pressure occurred in "3R" and results in a heavy steering force.

## EPS SYSTEM : Fail-Safe

INFOID:000000009012643

### EPS system

- EPS system enters the fail-safe mode (that allows the steering force to be controlled without impairing the drivability) if any of the input/output values to/from EPS system (power steering control unit) deviate from the standard range.
- The power steering control unit controls the driving voltage to the power steering solenoid valve for maintaining the power steering assist force when the fail-safe function is activated. (The engine speed signals control EPS system if any vehicle speed signal error is detected.)

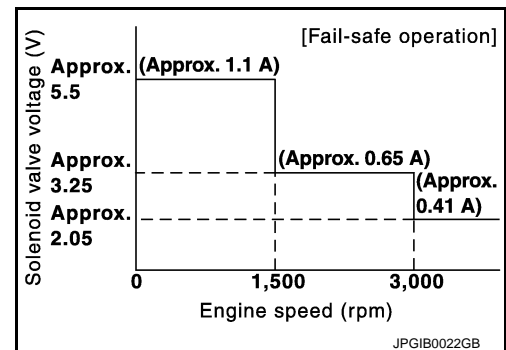

# SYSTEM

## < SYSTEM DESCRIPTION >

Error area and root cause	Cancel condition	
Engine speed is 1,500 rpm or more and there is no vehicle speed signal input for over 10 seconds during vehicle travel.	<ul style="list-style-type: none"><li>• When a vehicle speed signal of 2 km/h (1.2 MPH) or more is inputted.</li><li>• Ignition switch is turned OFF to ON.</li></ul>	A
Vehicle speed signal has abruptly dropped from 30 km/h (19 MPH) or more to 2 km/h (1.2 MPH) or less within 1.4 seconds.		B
		C
		D
		E
		F
		<b>STC</b>
		H
		I
		J
		K
		L
		M
		N
		O
		P

# POWER STEERING CONTROL UNIT

< ECU DIAGNOSIS INFORMATION >

## ECU DIAGNOSIS INFORMATION

### POWER STEERING CONTROL UNIT

Reference Value

INFOID:000000009012644

#### TERMINAL LAYOUT

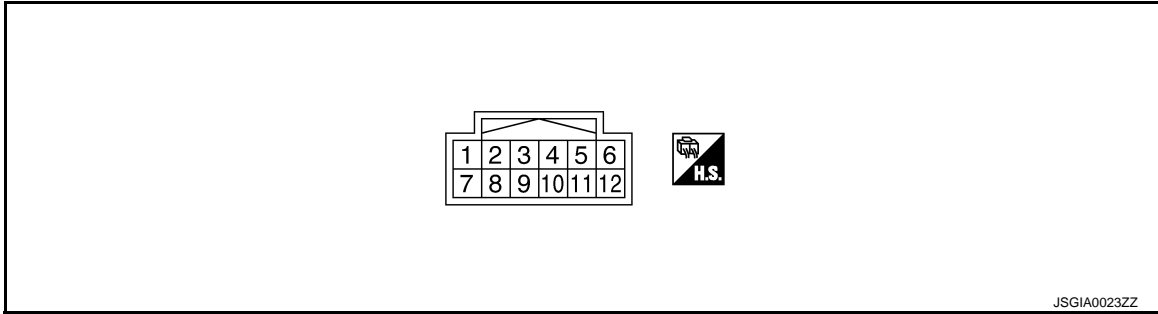

#### PHYSICAL VALUES

Terminal No. (Wire color)		Description		Condition	Value (Approx.)
+	-	Signal name	Input/ Output		
1 (R)	Ground	Power steering solenoid valve control voltage	Output	Vehicle speed: 0 km/h (0 MPH) (Engine is running)	4.4 – 6.6 V
				Vehicle speed: 100 km/h (62 MPH)	2.4 – 3.6 V
3 (GR)	Ground	Ignition switch power supply	Input	Ignition switch: ON	Battery voltage
				Ignition switch: OFF	0 V
5 (L)	Ground	Power steering solenoid valve ground	—	Always	0 V
6 (B)	Ground	Ground	—	Always	0 V
8 (SB)	Ground	Vehicle speed signal	Input	Vehicle speed: 40 km/h (25 MPH) <b>CAUTION:</b> Check air pressure of tire under standard condition.	<p><b>NOTE:</b> The maximum voltage varies de- pending on the specification (destination unit).</p> <p>JSNIA0015GB</p>



# POWER STEERING CONTROL UNIT

## < ECU DIAGNOSIS INFORMATION >

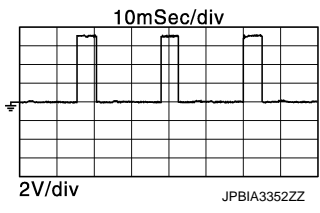
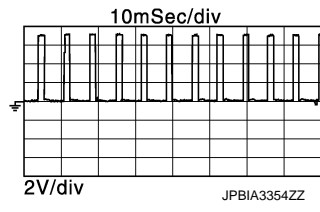
Terminal No. (Wire color)		Description		Condition	Value (Approx.)
+	-	Signal name	Input/ Output		
10 (B/SB)	Ground	Engine speed signal	Input	Engine is running • Warm-up condition • Idle speed	
				Engine is running • Warm-up condition • Engine speed: Approx. 2,000 rpm	

**CAUTION:**

When using circuit tester or oscilloscope to measure voltage for inspection, be sure not to forcibly extend any connector terminals.

### Fail-Safe

INFOID:000000009012645

#### EPS system

- EPS system enters the fail-safe mode (that allows the steering force to be controlled without impairing the drivability) if any of the input/output values to/from EPS system (power steering control unit) deviate from the standard range.
- The power steering control unit controls the driving voltage to the power steering solenoid valve for maintaining the power steering assist force when the fail-safe function is activated. (The engine speed signals control EPS system if any vehicle speed signal error is detected.)

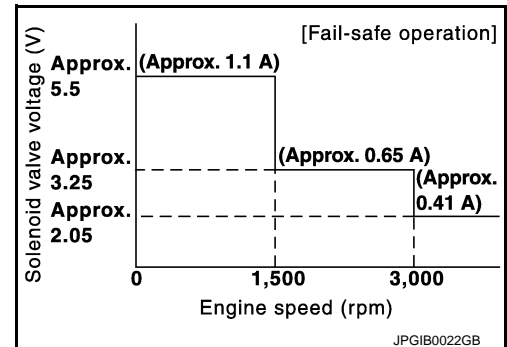

Error area and root cause	Cancel condition
Engine speed is 1,500 rpm or more and there is no vehicle speed signal input for over 10 seconds during vehicle travel.	<ul style="list-style-type: none"> <li>• When a vehicle speed signal of 2 km/h (1.2 MPH) or more is inputted.</li> <li>• Ignition switch is turned OFF to ON.</li> </ul>
Vehicle speed signal has abruptly dropped from 30 km/h (19 MPH) or more to 2 km/h (1.2 MPH) or less within 1.4 seconds.	

# ELECTRONICALLY CONTROLLED POWER STEERING SYSTEM

< WIRING DIAGRAM >

## WIRING DIAGRAM

### ELECTRONICALLY CONTROLLED POWER STEERING SYSTEM

Wiring Diagram

INFOID:000000009012646

#### ELECTRONICALLY CONTROLLED POWER STEERING SYSTEM

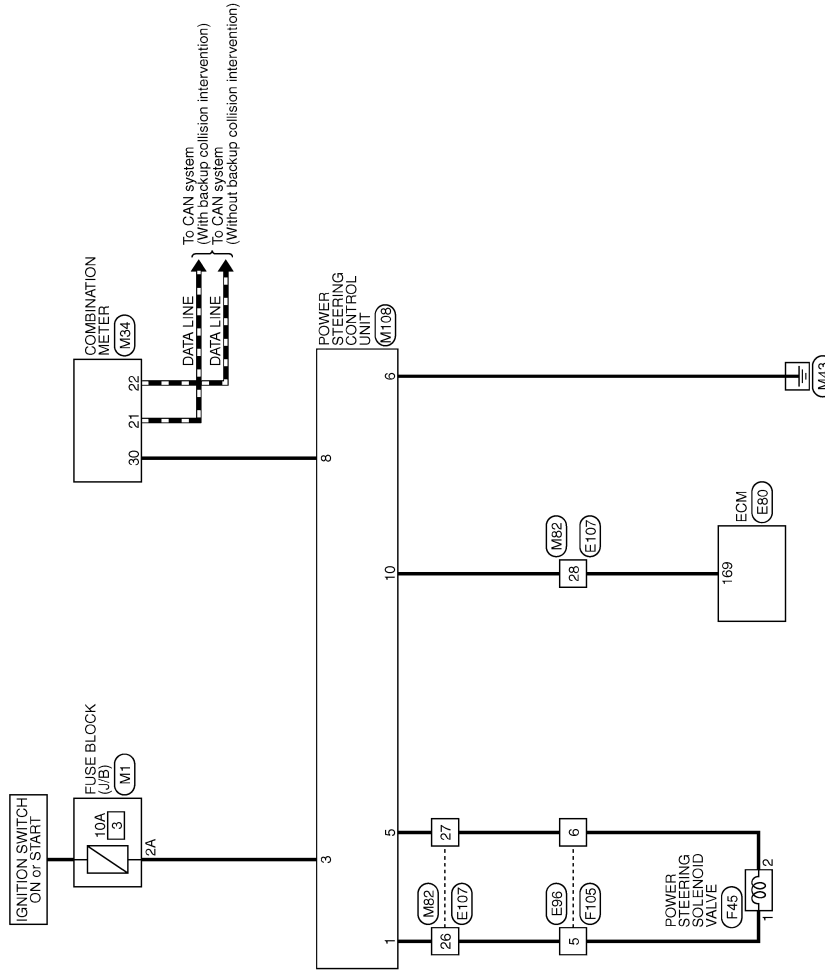

2013/01/30

JRGWC0188GB

# ELECTRONICALLY CONTROLLED POWER STEERING SYSTEM

< WIRING DIAGRAM >

## ELECTRONICALLY CONTROLLED POWER STEERING SYSTEM

Connector No.	E60
Connector Name	ECM
Connector Type	MAB55FB-MEB10-LH

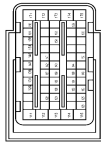

Connector No.	E96
Connector Name	WIRE TO WIRE
Connector Type	RS08MGY-PR



Terminal No.	Color Of Wire	Signal Name [Specification]
111	R	FUEL INJECTOR DRIVER POWER SUPPLY
112	SB	FUEL INJECTOR DRIVER POWER SUPPLY
113	G	ECM GROUND
114	B	ECM GROUND
115	B	ECM GROUND
120	Y	EVAP CANISTER VENT CONTROL VALVE
122	BRW	THROTTLE CONTROL MOTOR POWER SUPPLY
123	V/R	THROTTLE CONTROL MOTOR RELAY
125	GR	FUEL PUMP CONTROL MODULE (FPCM)
126	O	ACCELERATOR PEDAL POSITION SENSOR2
128	Y	ASC/DCS STEERING SWITCH
129	P/L	SENSOR GROUND
130	R	SENSOR GROUND
131	L/W	SENSOR POWER SUPPLY
133	SB	SENSOR POWER SUPPLY
134	V/W	FUEL TEMPERATURE SENSOR
136	W/R	ACCELERATOR PEDAL POSITION SENSOR 1
137	W/G	SENSOR POWER SUPPLY
138	V	BATTERY CURRENT SENSOR
139	G	BATTERY TEMPERATURE SENSOR
140	R/Y	SENSOR GROUND
141	SB	IGNITION SWITCH
142	R/W	FUEL PUMP CONTROL MODULE (FPCM) CHECK
143	L/Y	EVAP CONTROL SYSTEM PRESSURE SENSOR
144	O/B	REFRIGERANT PRESSURE SENSOR
146	L	CAN COMMUNICATION LINE
147	G/Y	ASC/DCS BRAKE SWITCH
150	R	SENSOR GROUND
151	P	CAN COMMUNICATION LINE
156	L	POWER SUPPLY FOR ECM (BACK-UP)
158	W/B	STOP LAMP SWITCH
161	R/W	ECM COMMUNICATION LINE
163	L/G	ECM RELAY (SELF SHUT-OFF)
165	GR/R	ECM COMMUNICATION LINE
166	W	ECM COMMUNICATION LINE

Terminal No.	Color Of Wire	Signal Name [Specification]
9	GR/L	
10	Y/R	
11	L/R	
12	W/G	
13	BR/Y	
14	LG	
15	BR/W	
16	B/Y	
17	W/B	
18	GR/R	
20	W/R	
21	B	
22	R/L	
23	GR	
24	R/W	
25	W/L	
26	R	
27	L	
28	GR/B	
35	G	
36	Y	
37	R	
38	G/Y	
39	O	
40	W	
41	R	
42	B	
43	G	
44	SHIELD	
46	B	
47	W	
48	SHIELD	
49	W	
50	SHIELD	
51	Y/R	
52	GR	
53	LG/B	
54	LG/R	
55	R/G	
56	BR	
57	SB	
60	G	
61	B	
62	W	
63	R	
64	SHIELD	
66	V	
68	Y	
67	BRW	

91	GR	
95	SB	
96	GR	
97	GR/L	
98	G/W	
99	R/Y	
100	L	

Connector No.	F45
Connector Name	POWER STEERING SOLENOID VALVE
Connector Type	RH02FB



Terminal No.	Color Of Wire	Signal Name [Specification]
1	R	EPS SOL+
2	L	EPS SOL-

Connector No.	F105
Connector Name	WIRE TO WIRE
Connector Type	RS08FGY-PR



Terminal No.	Color Of Wire	Signal Name [Specification]
1	W/L	
2	L/W	
3	GR	
4	BR	
5	R	
6	L	
7	W	

JRGWC0461GB

A  
B  
C  
D  
E  
F  
G  
H  
I  
J  
K  
L  
M  
N  
O  
P

STC

# ELECTRONICALLY CONTROLLED POWER STEERING SYSTEM

## < WIRING DIAGRAM >

### ELECTRONICALLY CONTROLLED POWER STEERING SYSTEM

Connector No.	M1
Connector Name	FUSE BLOCK (J/B)
Connector Type	NS08FW-M2

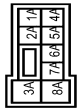

Terminal No.	Color Of Wire	Signal Name [Specification]
1A	Y	-
2A	GR	-
3A	W	-
4A	Y/G	-
5A	V	-
6A	LW	-
7A	LG	-
8A	W	-



Connector No.	M34
Connector Name	COMBINATION METER
Connector Type	TH40FW-NH



Terminal No.	Color Of Wire	Signal Name [Specification]
1	Y	BATTERY POWER SUPPLY
2	GR	IGNITION SIGNAL
3	B	GROUND
4	B	ILL GND
5	B	ILL CONTROL OUTPUT
7	R	TOW MODE SIGNAL
8	P/L	TRIP RESET SWITCH SIGNAL
11	G	ENTER SWITCH SIGNAL
12	O	SELECT SWITCH SIGNAL
13	W/R	ILLUMINATION CONTROL SWITCH SIGNAL (+)
14	R	ILLUMINATION CONTROL SWITCH SIGNAL (-)
15	RW	AIR BAG SIGNAL

18	W/R	AMBIENT SENSOR SIGNAL
19	V/W	AC AUTO AMP. CONNECTION SIGNAL
20	B	AMBIENT SENSOR GROUND
21	L	CAN-H
22	P	CAN-L
23	B	GROUND
24	V	FUEL LEVEL SENSOR GROUND
25	O/L	ALTERNATOR SIGNAL
26	W	PARKING BRAKE SWITCH SIGNAL
28	GR/R	SECURITY SIGNAL
29	BR	WASHER LEVEL SWITCH SIGNAL
30	SB	VEHICLE SPEED SIGNAL (2-PULSE)
31	BR/W	VEHICLE SPEED SIGNAL (8-PULSE)
33	W	SNOW MODE SIGNAL
34	BR/Y	FUEL LEVEL SENSOR SIGNAL
35	O/B	SEAT BELT BUCKLE SWITCH SIGNAL (DRIVER SIDE)
36	G/Y	PASSENGER SEAT BELT WARNING SIGNAL
37	R/Y	NON-MANUAL MODE SIGNAL
38	L/W	MANUAL MODE SHIFT DOWN SIGNAL
39	Y/B	MANUAL MODE SHIFT UP SIGNAL
40	G/W	MANUAL MODE SIGNAL

Connector No.	M82
Connector Name	WIRE TO WIRE
Connector Type	TH80FW-CS16-TM4

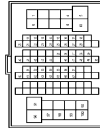

Terminal No.	Color Of Wire	Signal Name [Specification]
1	L	-
4	V/W	-
5	G/R	-
6	P	-
9	GR/L	-
10	Y/R	-
11	L/R	-
12	W/G	-
13	BR/Y	-
14	L/G	-
15	BR/W	-
16	B/Y	-
17	W/B	-

18	GR/R	-
20	W/R	-
21	B	-
22	R/L	-
23	GR	-
24	R/W	-
25	W/L	-
26	R	-
27	L	-
28	B/SB	-
35	G	-
36	Y	-
37	R	-
38	G/Y	-
39	O	-
40	W	-
41	R	-
42	B	-
43	C	-
44	SHIELD	-
46	B	-
47	W	-
48	SHIELD	-
49	W	-
50	SHIELD	-
51	Y/R	-
52	GR	-
53	LG/B	-
54	LG/R	-
55	R/G	-
56	B/O	-
57	SB	-
60	G	-
61	B	-
62	W	-
63	R	-
64	SHIELD	-
65	L/Y	-
66	V	-
67	B/W	-
91	G/R	-
95	SB	-
96	G/R	-
97	GR/L	-
98	G/W	-
99	P	-
100	L	-

Connector No.	M108
Connector Name	POWER STEERING CONTROL UNIT
Connector Type	TH12FW-NH

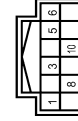

Terminal No.	Color Of Wire	Signal Name [Specification]
1	R	EPS SOL SUPPLY
3	GR	IGN
5	L	EPS SOL GND
6	B	GND
8	SB	VEHICLE SPEED (2P)
10	B/SB	ENG TACHO

# DIAGNOSIS AND REPAIR WORK FLOW

< BASIC INSPECTION >

## BASIC INSPECTION

### DIAGNOSIS AND REPAIR WORK FLOW

Work Flow

INFOID:000000009012647

DETAILED FLOW

#### 1. COLLECT THE INFORMATION FROM THE CUSTOMER

It is also important to clarify customer complaints before inspection. First of all, reproduce symptoms and understand them fully. Ask customer about his/her complaints carefully. In some cases, it is necessary to check symptoms by driving vehicle with customer.

**CAUTION:**

**Customers are not professional. It is dangerous to make an easy guess like “maybe the customer means that...,” or “maybe the customer mentions this symptom”.**

>> GO TO 2.

#### 2. CHECK THE STATUS

1. Power steering fluid leakage and check the power steering fluid level. Refer to [ST-30. "Inspection"](#).
2. Check the drive belt tension. Refer to [EM-20. "Checking"](#).
3. Check the power steering gear for damages, cracks and fluid leakage. Refer to [ST-46. "Inspection"](#).
4. Check the relief oil pressure. Refer to [ST-52. "Inspection"](#).

>> GO TO 3.

#### 3. DIAGNOSIS CHART BY SYMPTOM

Perform the diagnosis by symptom. Refer to [STC-22. "Diagnosis Procedure"](#).

>> GO TO 4.

#### 4. FINAL CHECK

Check the input/output standard values for the power steering control unit.

Are the power steering control unit input/output values within standard ranges respectively?

YES >> INSPECTION END

NO >> GO TO 2.

A  
B  
C  
D  
E  
F  
STC  
H  
I  
J  
K  
L  
M  
N  
O  
P

# POWER SUPPLY AND GROUND CIRCUIT

< DTC/CIRCUIT DIAGNOSIS >

## DTC/CIRCUIT DIAGNOSIS

### POWER SUPPLY AND GROUND CIRCUIT

#### Diagnosis Procedure

INFOID:000000009012648

#### 1. CHECK POWER SUPPLY (1)

1. Turn the ignition switch OFF.
2. Disconnect power steering control unit harness connector.
3. Check the voltage between power steering control unit harness connector and ground.

Power steering control unit		—	Voltage (Approx.)
Connector	Terminal		
M108	3	Ground	0 V

4. Turn the ignition switch ON.  
**CAUTION:**  
**Never start the engine.**
5. Check the voltage between power steering control unit harness connector and ground.

Power steering control unit		—	Voltage
Connector	Terminal		
M108	3	Ground	Battery voltage

Is the inspection result normal?

- YES >> GO TO 3.  
NO >> GO TO 2.

#### 2. CHECK POWER SUPPLY (2)

1. Turn the ignition switch OFF.
2. Check 10A fuse (#3).
3. Disconnect fuse block (J/B) harness connector.
4. Check the continuity between power steering control unit harness connector and fuse block (J/B) harness connector.

Power steering control unit		Fuse block (J/B)		Continuity
Connector	Terminal	Connector	Terminal	
M108	3	M1	2A	Existed

5. Check the continuity between power steering control unit harness connector and ground.

Power steering control unit		—	Continuity
Connector	Terminal		
M108	3	Ground	Not existed

Is the inspection result normal?

- YES >> Perform trouble diagnosis for ignition power supply circuit. Refer to [PG-59, "Wiring Diagram - IGNITION POWER SUPPLY -"](#).  
NO >> Repair or replace damaged parts.

#### 3. CHECK GROUND CIRCUIT

1. Turn the ignition switch OFF.
2. Check the continuity between power steering control unit harness connector and ground.

# POWER SUPPLY AND GROUND CIRCUIT

## < DTC/CIRCUIT DIAGNOSIS >

Power steering control unit		—	Continuity
Connector	Terminal		
M108	6	Ground	Existed

Is the inspection result normal?

YES >> GO TO 4.

NO >> Repair or replace error-detected parts.

### 4.CHECK TERMINALS AND HARNESS CONNECTORS

Check the power steering control unit pin terminals for damage or loose connection with harness connector.

Is the inspection result normal?

YES >> INSPECTION END

NO >> Repair or replace error-detected parts.

A  
B  
C  
D  
E  
F  
H  
I  
J  
K  
L  
M  
N  
O  
P

STC

# POWER STEERING SOLENOID VALVE

< DTC/CIRCUIT DIAGNOSIS >

## POWER STEERING SOLENOID VALVE

### Component Function Check

INFOID:000000009012649

#### 1. CHECK POWER STEERING SOLENOID VALVE OPERATION

Check changes in steering force from a halt condition to high-speed driving.

Is the inspection result normal?

YES >> INSPECTION END

NO >> Check the power steering solenoid valve. Refer to [STC-16, "Diagnosis Procedure"](#).

### Diagnosis Procedure

INFOID:000000009012650

#### 1. CHECK POWER STEERING SOLENOID VALVE SIGNAL

1. Turn the ignition switch OFF.
2. Check the voltage between power steering control unit harness connector and ground.

Power steering control unit		—	Condition	Voltage (Approx.)
Connector	Terminal			
M108	1	Ground	Vehicle speed: 0 km/h (0 MPH) (Engine is running)	4.4 – 6.6 V
			Vehicle speed: 100 km/h (62 MPH)	2.4 – 3.6 V

Is the inspection result normal?

YES >> GO TO 4.

NO >> GO TO 2.

#### 2. CHECK HARNESS BETWEEN POWER STEERING SOLENOID VALVE AND POWER STEERING CONTROL UNIT

1. Turn the ignition switch OFF.
2. Disconnect power steering solenoid valve harness connector.
3. Disconnect power steering control unit harness connector.
4. Check the continuity between power steering solenoid valve harness connector and the power steering control unit harness connector.

Power steering solenoid valve		Power steering control unit		Continuity
Connector	Terminal	Connector	Terminal	
F45	1	M108	1	Existed
	2		5	Existed

5. Check the continuity between power steering control unit harness connector and ground.

Power steering control unit		—	Continuity
Connector	Terminal		
M108	1	Ground	Not existed
	5		

Is the inspection result normal?

YES >> GO TO 3.

NO >> Repair or replace error-detected parts.

#### 3. CHECK POWER STEERING SOLENOID VALVE

Check the power steering solenoid valve. Refer to [STC-17, "Component Inspection"](#).

Is the inspection result normal?

YES >> GO TO 4.

NO >> Replace gear-sub assembly. Refer to [ST-43, "Disassembly and Assembly"](#).



# POWER STEERING SOLENOID VALVE

< DTC/CIRCUIT DIAGNOSIS >

## 4. CHECK TERMINALS AND HARNESS CONNECTORS

- Check the power steering control unit pin terminals for damage or loose connection with harness connector.
- Check the power steering solenoid valve pin terminals for damage or loose connection with harness connector.

Is the inspection result normal?

- YES >> Replace power steering control unit. Refer to [STC-23, "Removal and Installation"](#).  
NO >> Repair or replace error-detected parts.

## Component Inspection

INFOID:000000009012651

## 1. CHECK POWER STEERING SOLENOID VALVE

1. Turn the ignition switch OFF.
2. Disconnect power steering solenoid valve harness connector.
3. Check resistance between power steering solenoid valve connector terminals.

Power steering solenoid valve		Resistance (Approx.)
Terminal		
1	2	4 – 6 Ω

4. Check power steering solenoid valve by listening for its operation sound while applying battery voltage to power steering solenoid valve connector terminals 1 (positive) and 2 (negative).

Is the inspection result normal?

- YES >> INSPECTION END  
NO >> Replace gear-sub assembly. Refer to [ST-43, "Disassembly and Assembly"](#).

A  
B  
C  
D  
E  
F  
H  
I  
J  
K  
L  
M  
N  
O  
P

STC

# ENGINE SPEED SIGNAL CIRCUIT

< DTC/CIRCUIT DIAGNOSIS >

## ENGINE SPEED SIGNAL CIRCUIT

### Diagnosis Procedure

INFOID:000000009012652

#### 1. PERFORM ECM SELF-DIAGNOSIS

##### ④ With CONSULT

Perform "ENGINE" self-diagnosis.

Is any DTC detected?

YES >> Check the DTC. Refer to [EC-107, "DTC Index"](#) (For USA and CANADA), [EC-672, "DTC Index"](#) (For MEXICO).

NO >> GO TO 2.

#### 2. CHECK HARNESS BETWEEN ECM AND POWER STEERING CONTROL UNIT

1. Turn the ignition switch OFF.
2. Disconnect ECM harness connectors.
3. Disconnect power steering control unit harness connector.
4. Check the continuity between ECM harness connector and power steering control unit harness connector.

ECM		Power steering control unit		Continuity
Connector	Terminal	Connector	Terminal	
E80	169	M108	10	Existed

5. Check the continuity between power steering control unit harness connector and ground.

Power steering control unit		—	Continuity
Connector	Terminal		
M108	10	Ground	Not existed

Is the inspection result normal?

YES >> GO TO 3.

NO >> Repair or replace error-detected parts.

#### 3. CHECK ENGINE SPEED SIGNAL (ECM)

1. Connect ECM harness connectors.
2. Check the signal between ECM harness connector and ground with oscilloscope.

ECM		—	Condition	Voltage (Approx.)
Connector	Terminal			
E80	169	Ground	Engine is running <ul style="list-style-type: none"> <li>• Warm-up condition</li> <li>• Idle speed</li> </ul>	
			Engine is running <ul style="list-style-type: none"> <li>• Warm-up condition</li> <li>• Engine speed: Approx. 2,000 rpm</li> </ul>	

Is the inspection result normal?

YES >> GO TO 4.

# ENGINE SPEED SIGNAL CIRCUIT

## < DTC/CIRCUIT DIAGNOSIS >

NO >> Replace ECM. Refer to [EC-157, "Description"](#) (For USA and CANADA), [EC-720, "Description"](#) (For MEXICO).

### 4. CHECK ENGINE SPEED SIGNAL (POWER STEERING CONTROL UNIT)

1. Turn the ignition switch OFF.
2. Connect power steering control unit harness connector.
3. Check the signal between power steering control unit harness connector and ground with oscilloscope.

Power steering control unit		—	Condition	Voltage (Approx.)
Connector	Terminal			
M108	10	Ground	Engine is running <ul style="list-style-type: none"> <li>• Warm-up condition</li> <li>• Idle speed</li> </ul>	
			Engine is running <ul style="list-style-type: none"> <li>• Warm-up condition</li> <li>• Engine speed: Approx. 2,000 rpm</li> </ul>	

#### Is the inspection result normal?

YES >> GO TO 5.

NO >> Replace power steering control unit. Refer to [STC-23, "Removal and Installation"](#).

### 5. CHECK TERMINALS AND HARNESS CONNECTORS

- Check the power steering control unit pin terminals for damage or loose connection with harness connector.
- Check the ECM pin terminals for damage or loose connection with harness connector.

#### Is the inspection result normal?

YES >> INSPECTION END

NO >> Repair or replace error-detected parts.

# VEHICLE SPEED SIGNAL CIRCUIT

< DTC/CIRCUIT DIAGNOSIS >

## VEHICLE SPEED SIGNAL CIRCUIT

### Diagnosis Procedure

INFOID:000000009012653

#### 1. PERFORM COMBINATION METER SELF-DIAGNOSIS

##### Ⓜ With CONSULT

Perform "METER/M&A" self-diagnosis. Refer to [MWI-31, "CONSULT Function"](#).

Is any DTC detected?

- YES >> Check the DTC.
- NO >> GO TO 2.

#### 2. CHECK HARNESS BETWEEN COMBINATION METER AND POWER STEERING CONTROL UNIT

1. Turn the ignition switch OFF.
2. Disconnect combination meter harness connector.
3. Disconnect power steering control unit harness connector.
4. Check the continuity between combination meter harness connector and power steering control unit harness connector.

Combination meter		Power steering control unit		Continuity
Connector	Terminal	Connector	Terminal	
M34	30	M108	8	Existed

5. Check the continuity between power steering control unit harness connector and ground.

Power steering control unit		—	Continuity
Connector	Terminal		
M108	8	Ground	Not existed

Is the inspection result normal?

- YES >> GO TO 3.
- NO >> Repair or replace error-detected parts.

#### 3. CHECK VEHICLE SPEED SIGNAL (COMBINATION METER)

1. Connect combination meter harness connector.
2. Check the combination meter input/output standard values. Refer to [MWI-36, "Reference Value"](#).

Is the inspection result normal?

- YES >> GO TO 4.
- NO >> Replace combination meter Refer to [MWI-87, "Removal and Installation"](#).

#### 4. CHECK VEHICLE SPEED SIGNAL (POWER STEERING CONTROL UNIT)

1. Turn the ignition switch OFF.
2. Connect power steering control unit harness connector.
3. Check the signal between power steering control unit harness connector and ground with oscilloscope.

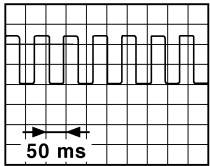
Power steering control unit		—	Condition	Voltage (Approx.)
Connector	Terminal			
M108	8	Ground	Vehicle speed: 40 km/h (25 MPH) <b>CAUTION:</b> Check air pressure of tire under standard condition.	<b>NOTE:</b> The maximum voltage varies depending on the specification (destination unit).  JSNIA0015GB

# VEHICLE SPEED SIGNAL CIRCUIT

## < DTC/CIRCUIT DIAGNOSIS >

---

Is the inspection result normal?

YES >> GO TO 5.

NO >> Replace power steering control unit. Refer to [STC-23. "Removal and Installation"](#).

### 5.CHECK TERMINALS AND HARNESS CONNECTORS

---

- Check the power steering control unit pin terminals for damage or loose connection with harness connector.
- Check the combination meter pin terminals for damage or loose connection with harness connector.

Is the inspection result normal?

YES >> INSPECTION END

NO >> Repair or replace error-detected parts.

A

B

C

D

E

F

STC

H

I

J

K

L

M

N

O

P

# UNBALANCE STEERING WHEEL TURNING FORCE (TORQUE VARIATION)

< SYMPTOM DIAGNOSIS >

## SYMPTOM DIAGNOSIS

### UNBALANCE STEERING WHEEL TURNING FORCE (TORQUE VARIATION)

#### Description

INFOID:000000009012654

- Hard steering when fully turning the steering wheel.
- Light steering when driving at a high speed.

#### Diagnosis Procedure

INFOID:000000009012655

#### 1. CHECK SYSTEM FOR POWER SUPPLY AND GROUND

Perform trouble diagnosis for power supply and ground. Refer to [STC-14, "Diagnosis Procedure"](#).

Is the inspection result normal?

- YES >> GO TO 2.
- NO >> Repair or replace error-detected parts.

#### 2. CHECK SYSTEM FOR VEHICLE SPEED SIGNAL

Perform trouble diagnosis for vehicle speed signal. Refer to [STC-20, "Diagnosis Procedure"](#).

Is the inspection result normal?

- YES >> GO TO 3.
- NO >> Repair or replace error-detected parts.

#### 3. CHECK SYSTEM FOR ENGINE SPEED SIGNAL

Perform trouble diagnosis for engine speed signal. Refer to [STC-18, "Diagnosis Procedure"](#).

Is the inspection result normal?

- YES >> GO TO 4.
- NO >> Repair or replace error-detected parts.

#### 4. CHECK SYSTEM FOR POWER STEERING SOLENOID VALVE

Perform trouble diagnosis for power steering solenoid valve. Refer to [STC-16, "Diagnosis Procedure"](#).

Is the inspection result normal?

- YES >> Perform the symptom diagnosis for the steering system. Refer to [ST-29, "NVH Troubleshooting Chart"](#).
- NO >> Repair or replace error-detected parts.

# POWER STEERING CONTROL UNIT

< REMOVAL AND INSTALLATION >

## REMOVAL AND INSTALLATION

### POWER STEERING CONTROL UNIT

#### Removal and Installation

INFOID:000000009012656

#### REMOVAL

1. Remove instrument lower cover. Refer to [IP-14, "Removal and Installation"](#).
2. Remove instrument lower panel RH. Refer to [IP-14, "Removal and Installation"](#).
3. Disconnect power steering control unit connector.
4. Remove power steering control unit.

#### INSTALLATION

Install in the reverse order of removal.

A

B

C

D

E

F

STC

H

I

J

K

L

M

N

O

P