

WT  
**SECTION**  
**ROAD WHEELS & TIRES**

A  
B  
C  
D

WT

**CONTENTS**

<p><b>PRECAUTION</b> ..... 3</p> <p><b>PRECAUTIONS</b> ..... 3</p> <p style="padding-left: 20px;">Precaution for Supplemental Restraint System (SRS) "AIR BAG" and "SEAT BELT PRE-TENSIONER" .....3</p> <p style="padding-left: 20px;">Precautions for Removing of Battery Terminal .....3</p> <p style="padding-left: 20px;">Service Notice and Precautions for TPMS .....3</p> <p style="padding-left: 20px;">Service Notice and Precautions for Road Wheel .....4</p> <p><b>PREPARATION</b> ..... 5</p> <p><b>PREPARATION</b> ..... 5</p> <p style="padding-left: 20px;">Special Service Tools .....5</p> <p style="padding-left: 20px;">Commercial Service Tools .....5</p> <p><b>SYSTEM DESCRIPTION</b> ..... 6</p> <p><b>COMPONENT PARTS</b> ..... 6</p> <p style="padding-left: 20px;">Component Parts Location .....6</p> <p style="padding-left: 20px;">Component Description .....7</p> <p style="padding-left: 20px;">Low Tire Pressure Warning Control Unit .....7</p> <p style="padding-left: 20px;">Tire pressure sensor .....7</p> <p style="padding-left: 20px;">Tire Pressure Receiver .....8</p> <p><b>SYSTEM</b> ..... 9</p> <p style="padding-left: 20px;">System Description .....9</p> <p style="padding-left: 20px;">Tire Inflation Indicator Function .....10</p> <p><b>DIAGNOSIS SYSTEM (LOW TIRE PRESSURE WARNING CONTROL UNIT)</b> .....12</p> <p style="padding-left: 20px;">CONSULT Function .....12</p> <p><b>ECU DIAGNOSIS INFORMATION</b> .....14</p> <p><b>LOW TIRE PRESSURE WARNING CONTROL UNIT</b> .....14</p> <p style="padding-left: 20px;">Reference Value .....14</p> <p style="padding-left: 20px;">DTC Inspection Priority Chart .....17</p> <p style="padding-left: 20px;">DTC Index .....18</p> <p><b>WIRING DIAGRAM</b> .....19</p>	<p><b>TIRE PRESSURE MONITORING SYSTEM</b> .....19</p> <p style="padding-left: 20px;">Wiring Diagram .....19</p> <p><b>BASIC INSPECTION</b> .....25</p> <p><b>DIAGNOSIS AND REPAIR WORK FLOW</b> .....25</p> <p style="padding-left: 20px;">Work Flow .....25</p> <p><b>ADDITIONAL SERVICE WHEN REPLACING LOW TIRE PRESSURE WARNING CONTROL UNIT</b> .....27</p> <p style="padding-left: 20px;">Description .....27</p> <p style="padding-left: 20px;">Work Procedure .....27</p> <p><b>TIRE PRESSURE SENSOR WAKE UP OPERATION</b> .....28</p> <p style="padding-left: 20px;">Description .....28</p> <p style="padding-left: 20px;">Work Procedure .....28</p> <p><b>ID REGISTRATION</b> .....29</p> <p style="padding-left: 20px;">Description .....29</p> <p style="padding-left: 20px;">Work Procedure .....29</p> <p><b>DTC/CIRCUIT DIAGNOSIS</b> .....30</p> <p><b>C1704, C1705, C1706, C1707 LOW TIRE PRESSURE</b> .....30</p> <p style="padding-left: 20px;">DTC Logic .....30</p> <p style="padding-left: 20px;">Diagnosis Procedure .....30</p> <p><b>C1708, C1709, C1710, C1711 TIRE PRESSURE SENSOR</b> .....32</p> <p style="padding-left: 20px;">DTC Logic .....32</p> <p style="padding-left: 20px;">Diagnosis Procedure .....32</p> <p><b>C1716, C1717, C1718, C1719 TIRE PRESSURE SENSOR</b> .....36</p> <p style="padding-left: 20px;">DTC Logic .....36</p> <p style="padding-left: 20px;">Diagnosis Procedure .....36</p> <p><b>C1728 RECEIVER ID</b> .....38</p> <p style="padding-left: 20px;">DTC Logic .....38</p>	<p>F</p> <p>G</p> <p>H</p> <p>I</p> <p>J</p> <p>K</p> <p>L</p> <p>M</p> <p>N</p> <p>O</p> <p>P</p>
----------------------------------------------------------------------------------------------------------------------------------------------------------------------------------------------------------------------------------------------------------------------------------------------------------------------------------------------------------------------------------------------------------------------------------------------------------------------------------------------------------------------------------------------------------------------------------------------------------------------------------------------------------------------------------------------------------------------------------------------------------------------------------------------------------------------------------------------------------------------------------------------------------------------------------------------------------------------------------------------------------------------------------------------------------------------------------------------------------------------------------------------------------------------------------------------------------------------------------------------------------------------------------------------------------------------------------------------------------------------------------------------------------------------------------------------------------------------------------------------------------------------------------------------------------------------------------------------------------------------------------------------------------------------------------------------------------------------------------------------------------------------------------	-------------------------------------------------------------------------------------------------------------------------------------------------------------------------------------------------------------------------------------------------------------------------------------------------------------------------------------------------------------------------------------------------------------------------------------------------------------------------------------------------------------------------------------------------------------------------------------------------------------------------------------------------------------------------------------------------------------------------------------------------------------------------------------------------------------------------------------------------------------------------------------------------------------------------------------------------------------------------------------------------------------------------------------------------------------------------------------------------------------------------------------------------------------------------------------------------------------------------------------------------------------------------------------------------------------------------------------------------------------------------------------------------------------------------------------------------------------------------------------------------------------------------------------------	----------------------------------------------------------------------------------------------------

Diagnosis Procedure .....	38	<b>TIRE INFLATION INDICATOR DOES NOT ACTIVATE .....</b>	<b>58</b>
<b>C1729 VEHICLE SPEED SIGNAL .....</b>	<b>40</b>	Description .....	58
DTC Logic .....	40	Diagnosis Procedure .....	58
Diagnosis Procedure .....	40	<b>ID REGISTRATION CANNOT BE COMPLET- ED .....</b>	<b>59</b>
<b>C1750, C1751, C1752, C1753 RECEIVER .....</b>	<b>41</b>	Description .....	59
DTC Logic .....	41	Diagnosis Procedure .....	59
Diagnosis Procedure .....	41	<b>NOISE, VIBRATION AND HARSHNESS (NVH) TROUBLESHOOTING .....</b>	<b>60</b>
<b>C1754 LOW TIRE PRESSURE WARNING CONTROL UNIT .....</b>	<b>44</b>	NVH Troubleshooting Chart .....	60
DTC Logic .....	44	<b>PERIODIC MAINTENANCE .....</b>	<b>61</b>
Diagnosis Procedure .....	44	<b>ROAD WHEEL .....</b>	<b>61</b>
<b>C1755, C1756, C1757, C1758 POOR RE- CEIVING CONDITIONS .....</b>	<b>46</b>	Adjustment .....	61
DTC Logic .....	46	Tire Rotation .....	62
Diagnosis Procedure .....	46	<b>REMOVAL AND INSTALLATION .....</b>	<b>63</b>
<b>U1000 CAN COMM CIRCUIT .....</b>	<b>48</b>	<b>ROAD WHEEL TIRE ASSEMBLY .....</b>	<b>63</b>
Description .....	48	Exploded View .....	63
DTC Logic .....	48	Removal and Installation .....	63
Diagnosis Procedure .....	48	Inspection .....	63
<b>U1010 CONTROL UNIT (CAN) .....</b>	<b>49</b>	<b>LOW TIRE PRESSURE WARNING CON- TROL UNIT .....</b>	<b>64</b>
Description .....	49	Exploded View .....	64
DTC Logic .....	49	Removal and Installation .....	64
Diagnosis Procedure .....	49	<b>TIRE PRESSURE SENSOR .....</b>	<b>65</b>
<b>POWER SUPPLY AND GROUND CIRCUIT ....</b>	<b>50</b>	Exploded View .....	65
Diagnosis Procedure .....	50	Removal and Installation .....	65
<b>LOW TIRE PRESSURE WARNING LAMP .....</b>	<b>51</b>	<b>TIRE PRESSURE RECEIVER .....</b>	<b>67</b>
Component Function Check .....	51	Exploded View .....	67
Diagnosis Procedure .....	51	<b>FRONT TIRE PRESSURE RECEIVER .....</b>	<b>67</b>
<b>SYMPTOM DIAGNOSIS .....</b>	<b>52</b>	FRONT TIRE PRESSURE RECEIVER : Removal and Installation .....	67
<b>TPMS SYMPTOMS .....</b>	<b>52</b>	<b>REAR TIRE PRESSURE RECEIVER .....</b>	<b>67</b>
Symptom Table .....	52	REAR TIRE PRESSURE RECEIVER : Removal and Installation .....	67
<b>LOW TIRE PRESSURE WARNING LAMP DOES NOT TURN ON .....</b>	<b>55</b>	<b>SERVICE DATA AND SPECIFICATIONS (SDS) .....</b>	<b>68</b>
Description .....	55	<b>SERVICE DATA AND SPECIFICATIONS (SDS) .....</b>	<b>68</b>
Diagnosis Procedure .....	55	Road Wheel .....	68
<b>LOW TIRE PRESSURE WARNING LAMP DOES NOT TURN OFF .....</b>	<b>56</b>	Tire Air Pressure .....	68
Description .....	56		
Diagnosis Procedure .....	56		
<b>LOW TIRE PRESSURE WARNING LAMP BLINKS .....</b>	<b>57</b>		
Description .....	57		
Diagnosis Procedure .....	57		

# PRECAUTIONS

< PRECAUTION >

## PRECAUTION

### PRECAUTIONS

#### Precaution for Supplemental Restraint System (SRS) "AIR BAG" and "SEAT BELT PRE-TENSIONER"

INFOID:000000009814497

The Supplemental Restraint System such as "AIR BAG" and "SEAT BELT PRE-TENSIONER", used along with a front seat belt, helps to reduce the risk or severity of injury to the driver and front passenger for certain types of collision. Information necessary to service the system safely is included in the "SRS AIR BAG" and "SEAT BELT" of this Service Manual.

#### **WARNING:**

Always observe the following items for preventing accidental activation.

- To avoid rendering the SRS inoperative, which could increase the risk of personal injury or death in the event of a collision that would result in air bag inflation, all maintenance must be performed by an authorized NISSAN/INFINITI dealer.
- Improper maintenance, including incorrect removal and installation of the SRS, can lead to personal injury caused by unintentional activation of the system. For removal of Spiral Cable and Air Bag Module, see "SRS AIR BAG".
- Never use electrical test equipment on any circuit related to the SRS unless instructed to in this Service Manual. SRS wiring harnesses can be identified by yellow and/or orange harnesses or harness connectors.

#### PRECAUTIONS WHEN USING POWER TOOLS (AIR OR ELECTRIC) AND HAMMERS

#### **WARNING:**

Always observe the following items for preventing accidental activation.

- When working near the Air Bag Diagnosis Sensor Unit or other Air Bag System sensors with the ignition ON or engine running, never use air or electric power tools or strike near the sensor(s) with a hammer. Heavy vibration could activate the sensor(s) and deploy the air bag(s), possibly causing serious injury.
- When using air or electric power tools or hammers, always switch the ignition OFF, disconnect the battery, and wait at least 3 minutes before performing any service.

#### Precautions for Removing of Battery Terminal

INFOID:000000009864289

- When removing the 12V battery terminal, turn OFF the ignition switch and wait at least 30 seconds.

#### **NOTE:**

ECU may be active for several tens of seconds after the ignition switch is turned OFF. If the battery terminal is removed before ECU stops, then a DTC detection error or ECU data corruption may occur.

- For vehicles with the 2-batteries, be sure to connect the main battery and the sub battery before turning ON the ignition switch.

#### **NOTE:**

If the ignition switch is turned ON with any one of the terminals of main battery and sub battery disconnected, then DTC may be detected.

- After installing the 12V battery, always check "Self Diagnosis Result" of all ECUs and erase DTC.

#### **NOTE:**

The removal of 12V battery may cause a DTC detection error.

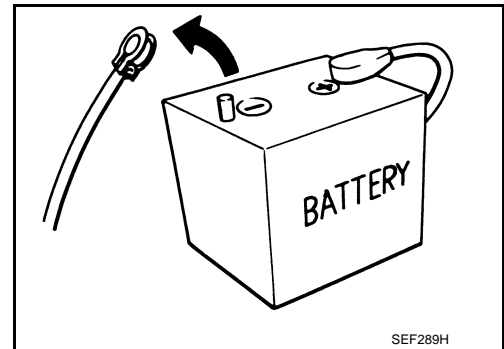

#### Service Notice and Precautions for TPMS

INFOID:000000009008426

- Low tire pressure warning lamp blinks for 1min, then turns ON when occurring any malfunction except low tire pressure. Erase the self-diagnosis memories for low tire pressure warning control unit, or register the ID to turn low tire pressure warning lamp OFF. For ID registration, refer to [WT-29, "Work Procedure"](#).
- ID registration is required when replacing or rotating wheels, replacing tire pressure sensor or low tire pressure warning control unit. Refer to [WT-29, "Work Procedure"](#).
- Replace grommet seal, valve core and cap of tire pressure sensor in TPMS, when replacing each tire by reaching the wear limit. Refer to [WT-65, "Exploded View"](#).

# PRECAUTIONS

## < PRECAUTION >

---

- For tire inflation indicator function, refer to the following.
- When inflating the tires, park the vehicle in the safe area and ensure the safety of the working area.
- Read and understand the tire inflation indicator function prior to use.
- Inflate the tires one at a time.
- If there is no response for approximately 15 seconds or more after inflating the tires, cancel the use of the tire inflation indicator function or move the vehicle approximately 1 m (3.2 ft) backward or forward to try again. The air filler pressure may be weak or out of service area.
- Despite the high-precision TPMS pressure sensor, an indicated value may differ from that of the pressure gauge.
- Air pressure is measured rather high due to the rise in tire air temperature after driving.
- If TPMS is malfunctioning, the tire inflation indicator is unusable.

## Service Notice and Precautions for Road Wheel

INFOID:000000009008427

- Genuine NISSAN aluminum wheel is designed for each type of vehicle. Use it on the specified vehicle only.
- Use Genuine NISSAN parts for the wheel nuts.
- Always use them after adjusting the wheel balance. For the balance weights, use Genuine NISSAN aluminum wheel weights.
- Use caution when handling the aluminum wheels, because they can be easily scratched. When removing dirt, do not use any abrasives, a wire brush, or other items that may scratch the coating. Use a neutral detergent if a detergent is needed.
- After driving on roads scattered with anti-icing salts, wash off the wheels completely.
- When installing road wheels onto the vehicle, always wipe off any dirt or foreign substances to prevent them from being trapped between the contact surfaces of wheel.
- Never apply oil to nut and bolt threads.

# PREPARATION

< PREPARATION >

## PREPARATION

### PREPARATION

#### Special Service Tools

INFOID:000000009008428

The actual shapes of Kent-Moore tools may differ from those of special service tools illustrated here.

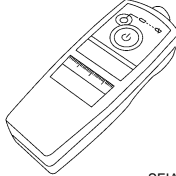
Tool number (Kent-Moore No.) Tool name	Description
– (J-45295) Activation tool   SEIA0462E	Tire pressure sensor wake-up procedure and ID registration.

#### Commercial Service Tools

INFOID:000000009008429

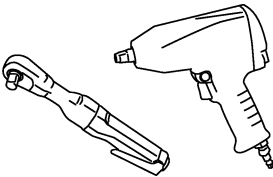
Tool name	Description
Power tool   PBIC0190E	Loosening wheel nuts

# COMPONENT PARTS

< SYSTEM DESCRIPTION >

## SYSTEM DESCRIPTION

### COMPONENT PARTS

#### Component Parts Location

INFOID:000000009008430

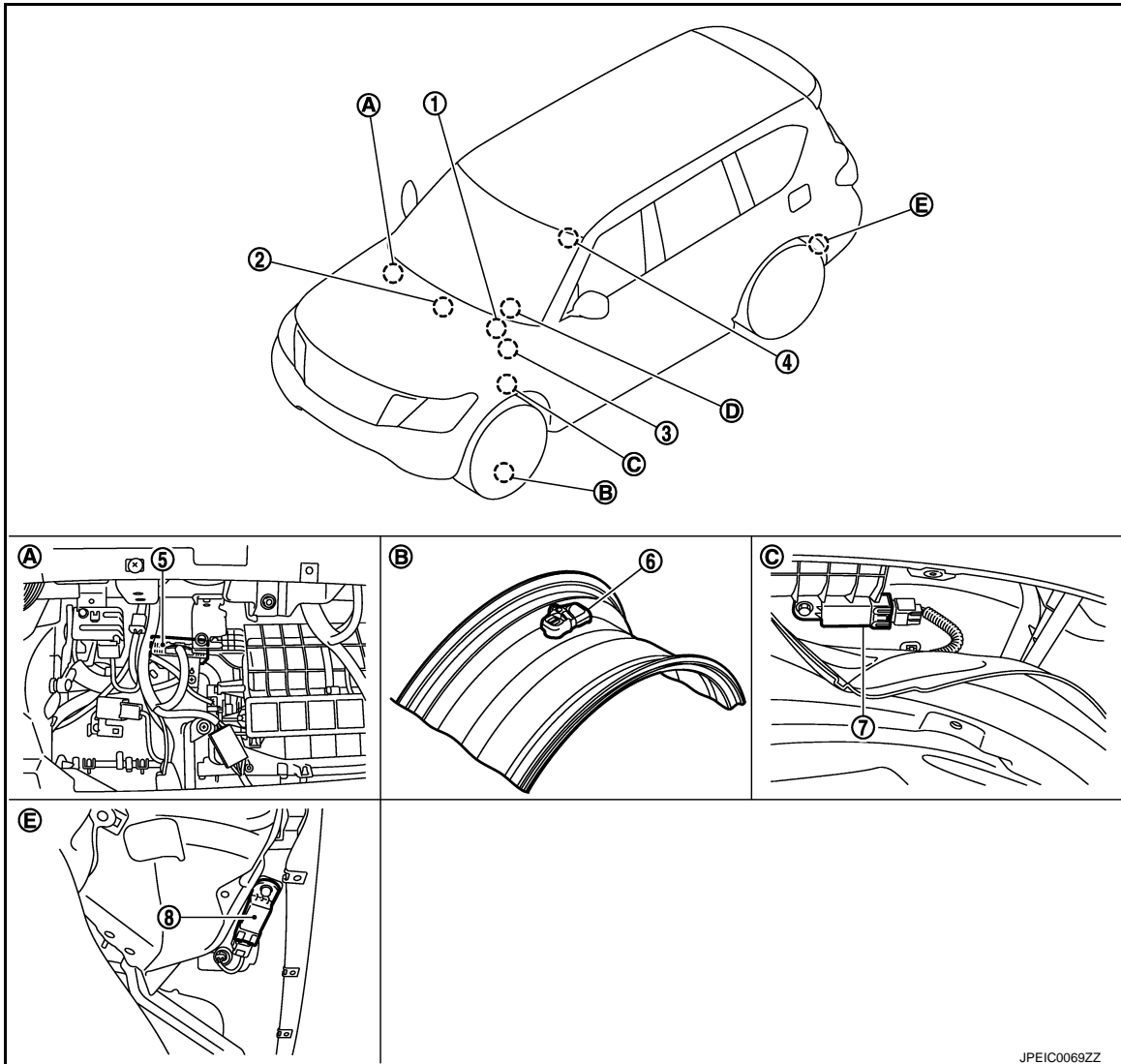

- |                                                                                              |                                                                                    |                                                                                                                  |
|----------------------------------------------------------------------------------------------|------------------------------------------------------------------------------------|------------------------------------------------------------------------------------------------------------------|
| 1. BCM<br>Refer to <a href="#">BCS-4, "BODY CONTROL SYSTEM : Component Parts Location"</a> . | 2. AV control unit<br>Refer to <a href="#">AV-12, "Component Parts Location"</a> . | 3. ABS actuator and electric unit (control unit)<br>Refer to <a href="#">BRC-9, "Component Parts Location"</a> . |
| 4. TCM*<br>Refer to <a href="#">TM-11, "A/T CONTROL SYSTEM : Component Parts Location"</a> . | 5. Low tire pressure warning control unit                                          | 6. Tire pressure sensor                                                                                          |
| 7. Front tire pressure receiver                                                              | 8. Rear tire pressure receiver                                                     |                                                                                                                  |
| A. Glove box assembly removed                                                                | B. Wheel                                                                           | C. Fender protector (rear side)                                                                                  |
| D. Low tire pressure warning lamp (in combination meter)                                     | E. Inside rear wheel house protector                                               |                                                                                                                  |

\*: TCM used for the tire inflation indicator function.

# COMPONENT PARTS

< SYSTEM DESCRIPTION >

## Component Description

INFOID:000000009008431

Component parts	Reference/Function
Tire pressure sensor	<a href="#">WT-7, "Tire pressure sensor"</a>
Tire pressure receiver	<a href="#">WT-8, "Tire Pressure Receiver"</a>
Low tire pressure warning control unit	<a href="#">WT-7, "Low Tire Pressure Warning Control Unit"</a>
Low tire pressure warning lamp	<a href="#">WT-9, "System Description"</a>
AV control unit	<a href="#">AV-13, "Component Description"</a>
BCM	<a href="#">BCS-6, "BODY CONTROL SYSTEM : System Description"</a>
ABS actuator and electric unit (control unit)	<a href="#">BRC-15, "System Description"</a>
TCM*	<a href="#">TM-11, "A/T CONTROL SYSTEM : Component Parts Location"</a>

\*: TCM used for the tire inflation function.

### Low Tire Pressure Warning Control Unit

INFOID:000000009008432

- After the low tire pressure warning control unit (1) receives the tire pressure signal from the tire pressure receiver, it controls the operation of the low tire pressure warning lamp, hazard warning lamp, and horn.

**NOTE:**

The hazard warning lamp and the horn are used for the tire inflation indicator function.

- Performs self-diagnosis of the Tire Pressure Monitoring System (TPMS).
- Controls tire inflation indicator function.

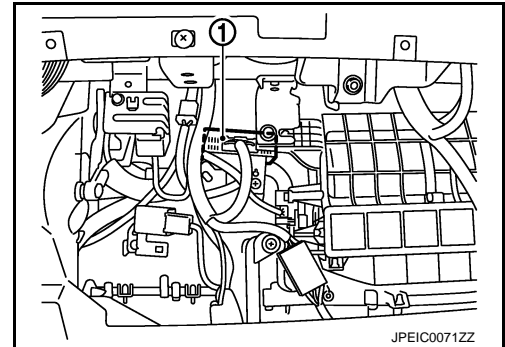

### Tire pressure sensor

INFOID:000000009008433

The tire pressure sensor (1) is installed at the position of the air valve on the road wheel (2). It measures the tire pressure and transmits the tire pressure information by radio waves.

⇐ : Outside

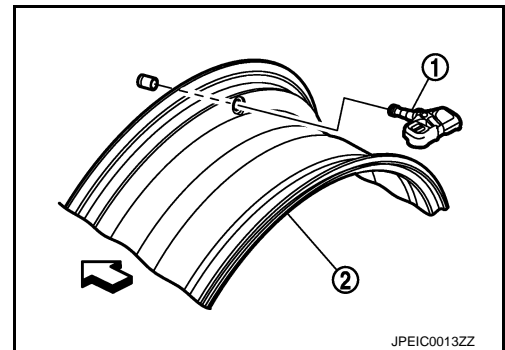

# COMPONENT PARTS

## < SYSTEM DESCRIPTION >

### Tire Pressure Receiver

INFOID:000000009008434

The front tire pressure receiver (1) and rear tire pressure receiver (2) receive the tire pressure signal by radio waves from the tire pressure sensor at each wheel, and transmit the tire pressure signal to the low tire pressure warning control unit.

A : Front side

B : Rear side

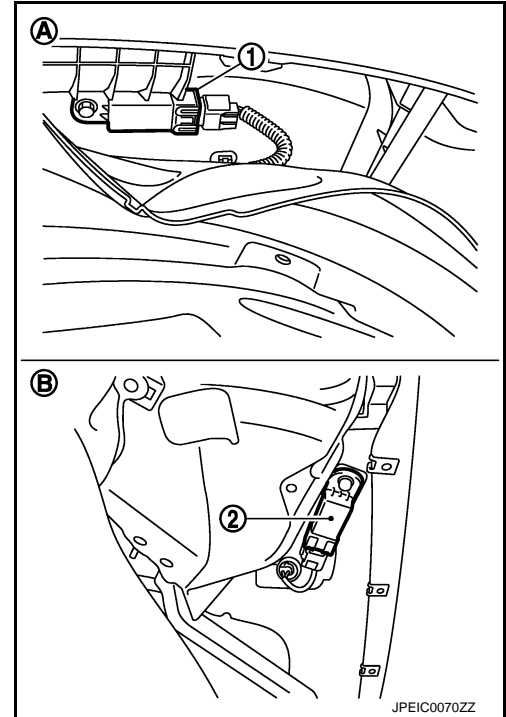

JPEIC0070ZZ



# SYSTEM

< SYSTEM DESCRIPTION >

## SYSTEM

### System Description

INFOID:000000009008435

- During driving, the TPMS (Tire Pressure Monitoring System) receives the signal transmitted from tire pressure sensor installed in each wheel. The low tire pressure warning control unit has pressure judgment and trouble diagnosis functions. When the low tire pressure warning control unit detects low inflation pressure or another unusual symptom, the low tire pressure warning lamps in the combination meter comes on.
- If the tire pressure is less than the specified value, the low tire pressure warning lamp illuminates that the tire pressure is less than the specified value.
- Activates the TPMS (Tire Pressure Monitoring System) when the vehicle speed is 40 km/h (25 MPH) or more.
- The tire pressure information for each wheel is displayed on the vehicle information display.
- Added tire inflation indicator function to TPMS (Tire Pressure Monitoring System). Refer to [WT-10. "Tire Inflation Indicator Function"](#).

### SYSTEM DIAGRAM

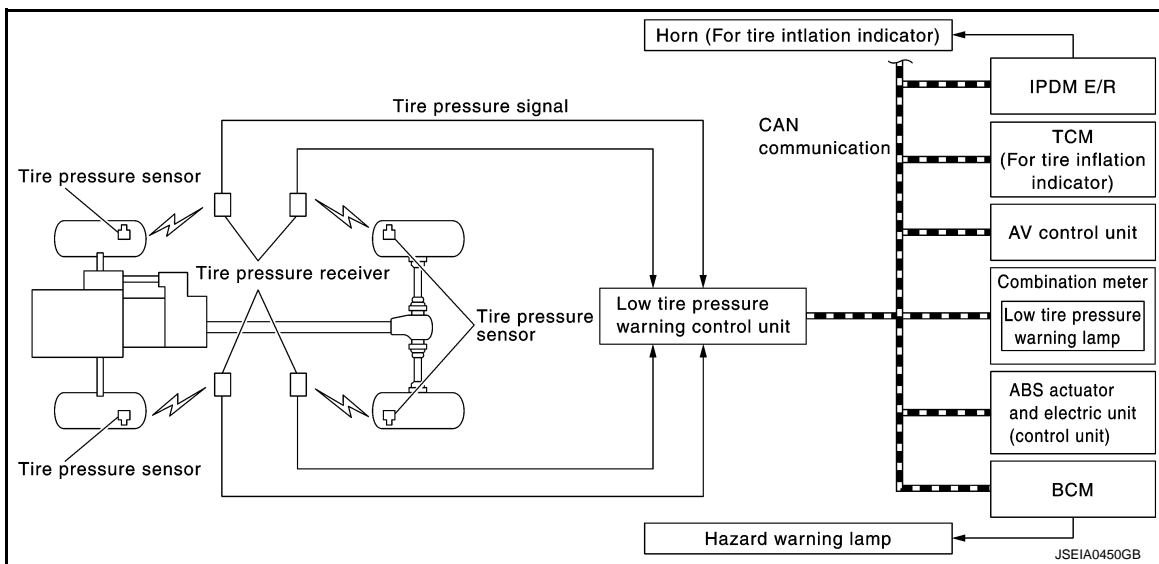

### INPUT/OUTPUT SIGNAL

The signal transmission/reception between units via a communication line is mainly as listed in the following table.

Component parts	Signal item
Low tire pressure warning control unit	Transmits the following signals via CAN communication to BCM. <ul style="list-style-type: none"> <li>• Low tire pressure warning lamp signal</li> <li>• Hazard request signal</li> <li>• Horn request signal*</li> </ul> Transmits the following signals via CAN communication to the AV control unit. <ul style="list-style-type: none"> <li>• Low tire pressure warning lamp signal</li> <li>• Tire pressure data signal</li> </ul>
BCM	Transmits the following signal via CAN communication to the combination meter, based on signals from low tire pressure warning control unit. <ul style="list-style-type: none"> <li>• Low tire pressure warning lamp signal</li> </ul> Transmits the following signal via CAN communication to the IPDM E/R, based on signals from low tire pressure warning control unit. <ul style="list-style-type: none"> <li>• Horn request signal*</li> </ul> Receives the following signal via CAN communication from low tire pressure warning control unit. <ul style="list-style-type: none"> <li>• Hazard request signal</li> </ul>
AV control unit	Receives the following signals via CAN communication from low tire pressure warning control unit. <ul style="list-style-type: none"> <li>• Low tire pressure warning lamp signal</li> <li>• Tire pressure data signal</li> </ul>

# SYSTEM

## < SYSTEM DESCRIPTION >

Component parts	Signal item
ABS actuator and electric unit (control unit)	Transmits the vehicle speed signal (ABS) via CAN communication for low tire pressure warning control unit.
TCM*	Transmits the P range signal via CAN communication for low tire pressure warning control unit.

\*: TCM used for the tire inflation indicator function.

### LOW TIRE PRESSURE WARNING LAMP CONTROL CONDITION

Uses CAN communication from the low tire pressure warning control unit to illuminate the low tire pressure warning lamp on the combination meter.

Condition	Low tire pressure warning lamp
Ignition switch OFF	OFF
Ignition switch ON (system normal)	Warning lamp turns on for 1second, then turns off.
Low tire pressure	ON
Tire pressure sensor ID not registered in Low tire pressure warning control unit.	
Tire pressure monitoring system malfunction (Other diagnostic item)	Warning lamp blinks 1 min, then turns on.
Tire pressure sensor is in OFF state	Blink (Blinking pattern depends on the positions of non-operational tire pressure sensors.)
When performing tire pressure sensor wake-up operation	Refer to <a href="#">WT-28, "Work Procedure"</a> .

### HAZARD WARNING LAMP CONTROL CONDITION

The low tire pressure warning control unit transmits a hazard request signal to BCM. BCM blinks the hazard warning lamp, according to the signal.

The hazard warning lamp blinks under the following conditions.

Condition of Blinking The Hazard Warning Lamp

- When wake-up of registered wheel has been completed. Refer to [WT-28, "Work Procedure"](#).
- When ID registration is completed. Refer to [WT-29, "Work Procedure"](#).
- During the use of the tire inflation indicator function.

### HORN CONTROL CONDITION

The low tire pressure warning control unit transmits a horn request signal to BCM. BCM controls horn sound, according to the signal.

The horn sounds under the following condition.

Condition of Sounding Horn

- During the use of tire inflation indicator function.

### Tire Inflation Indicator Function

INFOID:000000009008436

- This function operates only when the A/T shift selector position is in P-range with the ignition switch ON or with the engine started.

#### NOTE:

The tire inflation indicator function is recommended to use with the engine stopped.

- This function informs the driver of the satisfaction of the recommended COLD tire pressure.

The hazard warning lamp blinks when reaching the recommended COLD tire pressure during radio wave reception. After reaching the recommended COLD tire pressure, the horn sounds once and the hazard warning lamp stops blinking.

- When tire pressure becomes a value equal to or more than 30 kPa (0.31 kg/cm<sup>2</sup>, 4 psi) more than the recommended COLD tire pressure, the hazard warning lamp and the horn operates three times.

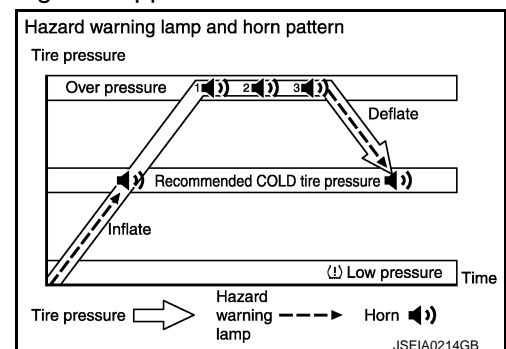

# SYSTEM

## < SYSTEM DESCRIPTION >

---

After deflating the tire and reaching the recommended COLD tire pressure, the horn sounds only once and the hazard warning lamp stops blinking.

**NOTE:**

- After starting to inflate the tire, it takes a few seconds for the tire inflation indicator to function.
- If there is no response for approximately 15 seconds or more after inflating the tires, cancel the use of the tire inflation indicator function or move the vehicle approximately 1 m (3.2 ft) backward or forward to try again. The air filler pressure may be weak or out of service area.

A  
B  
C  
D  
E  
F  
G  
H  
I  
J  
K  
L  
M  
N  
O  
P

WT

# DIAGNOSIS SYSTEM (LOW TIRE PRESSURE WARNING CONTROL UNIT)

< SYSTEM DESCRIPTION >

## DIAGNOSIS SYSTEM (LOW TIRE PRESSURE WARNING CONTROL UNIT)

### CONSULT Function

INFOID:000000009008437

### APPLICATION ITEMS

CONSULT performs the following functions in combination of data reception, instruction, and transmission via communication lines from low tire pressure warning control unit.

Mode	FUNCTION DESCRIPTION
ECU IDENTIFICATION	Displays the part number of low tire pressure warning control unit.
SELF-DIAGNOSIS RESULTS	Self-diagnosis result can be quickly read.*
DATA MONITOR	Input and output data of low tire pressure warning control unit can be read.
ACTIVE TEST	Sends command to the low tire pressure warning control unit to change output signals and check operation of output system.
WORK SUPPORT	Components can be quickly and accurately adjusted.

\*: The following diagnosis information is erased by erasing.

- DTC

### ECU IDENTIFICATION

Part number of low tire pressure warning control unit is displayed.

### SELF DIAGNOSIS RESULTS

Refer to [WT-18, "DTC Index"](#).

### DATA MONITOR

#### NOTE:

The following table includes information (items) inapplicable to this vehicle. For information (items) applicable to this vehicle, refer to CONSULT display items.

Monitor item (Unit)	Remarks
VHCL SPEED SE [(km/h) or (MPH)]	Vehicle speed is displayed.
AIR PRESS FL [(kPa), (kg/cm <sup>2</sup> ) or (Psi)]	Air pressure of front LH tires is displayed.
AIR PRESS FR [(kPa), (kg/cm <sup>2</sup> ) or (Psi)]	Air pressure of front RH tires is displayed.
AIR PRESS RR [(kPa), (kg/cm <sup>2</sup> ) or (Psi)]	Air pressure of rear RH tires is displayed.
AIR PRESS RL [(kPa), (kg/cm <sup>2</sup> ) or (Psi)]	Air pressure of rear LH tires is displayed.
ID REGST FL1	ID registration status of front LH tire pressure sensor is displayed.
ID REGST FR1	ID registration status of front RH tire pressure sensor is displayed.
ID REGST RR1	ID registration status of rear RH tire pressure sensor is displayed.
ID REGST RL1	ID registration status of rear LH tire pressure sensor is displayed.
WARNING LAMP	Control status of low tire pressure warning lamp is displayed.
BUZZER	Control status of buzzer in combination meter by low tire pressure warning control unit is displayed. <b>NOTE:</b> Not use in TPMS, but displayed.

### ACTIVE TEST

#### NOTE:

After completing the work below, perform an active test.

# DIAGNOSIS SYSTEM (LOW TIRE PRESSURE WARNING CONTROL UNIT)

## < SYSTEM DESCRIPTION >

1. Check ID registration state and perform self-diagnosis.
2. Erase the self-diagnosis result history.

Test item	Condition	Description
BUZZER	<ul style="list-style-type: none"><li>• Vehicle stopped</li><li>• The system is normal</li></ul>	This test is able to check to check that the buzzer operates. <b>NOTE:</b> Not use in TPMS, but displayed.
WARN LAMP		This test is able to check to check that the low tire pressure warning lamp turns on.

## WORK SUPPORT

Item	Usage
ID REGIST	Use to ID registration. Refer to <a href="#">WT-29, "Work Procedure"</a> .

A  
B  
C  
D  
WT  
F  
G  
H  
I  
J  
K  
L  
M  
N  
O  
P

# LOW TIRE PRESSURE WARNING CONTROL UNIT

< ECU DIAGNOSIS INFORMATION >

## ECU DIAGNOSIS INFORMATION

### LOW TIRE PRESSURE WARNING CONTROL UNIT

#### Reference Value

INFOID:000000009008438

#### VALUES ON THE DIAGNOSIS TOOL

#### CAUTION:

The reference values in the table below come from the control unit calculation data. The normal values may in some cases be displayed even though the power circuit (harness) is open or shorted.

#### NOTE:

The following table includes information (items) inapplicable to this vehicle. For information (items) applicable to this vehicle, refer to CONSULT display items.

Monitor item	Condition	Value/Status
VHCL SPEED SE	Vehicle stopped	0.00 km/h (0.00 mph)
	Vehicle running <b>CAUTION:</b> Check air pressure of tire under standard condition.	Approx. equal to the indication on speedometer (Inside of $\pm 10\%$ )
AIR PRESS FL	Start engine and drive at 40 km/h (25 MPH) or more for 10 minutes.	Approximately equal to the indication on tire gauge value for front LH tire
AIR PRESS FR	Start engine and drive at 40 km/h (25 MPH) or more for 10 minutes.	Approximately equal to the indication on tire gauge value for front RH tire
AIR PRESS RR	Start engine and drive at 40 km/h (25 MPH) or more for 10 minutes.	Approximately equal to the indication on tire gauge value for rear RH tire
AIR PRESS RL	Start engine and drive at 40 km/h (25 MPH) or more for 10 minutes.	Approximately equal to the indication on tire gauge value for rear LH tire
ID REGST FL1	Front LH tire pressure sensor ID registered	Done
	Front LH tire pressure sensor ID unregistered	Yet
ID REGST FR1	Front RH tire pressure sensor ID registered	Done
	Front RH tire pressure sensor ID unregistered	Yet
ID REGST RR1	Rear RH tire pressure sensor ID registered	Done
	Rear RH tire pressure sensor ID unregistered	Yet
ID REGST RL1	Rear LH tire pressure sensor ID registered	Done
	Rear LH tire pressure sensor ID unregistered	Yet
WARNING LAMP	Low tire pressure warning lamp: ON	On
	Low tire pressure warning lamp: OFF	Off

#### TERMINAL LAYOUT

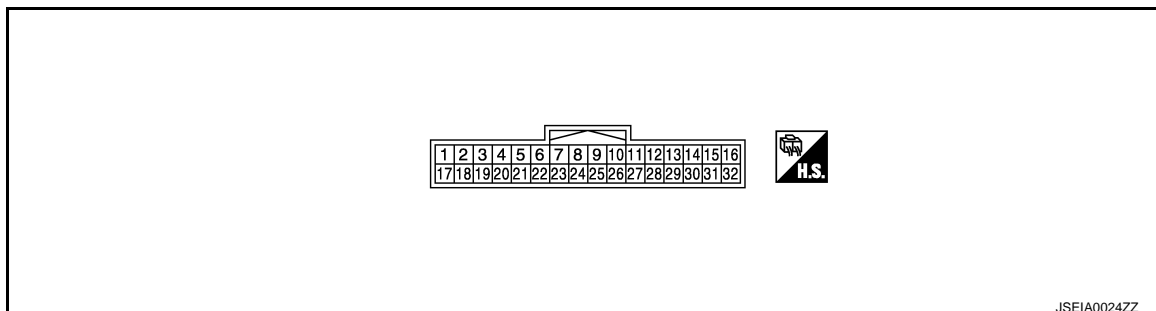

JSEIA0024ZZ





#### PHYSICAL VALUES

#### CAUTION:

# LOW TIRE PRESSURE WARNING CONTROL UNIT

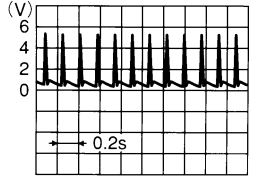
< ECU DIAGNOSIS INFORMATION >

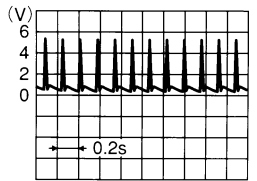
**When using circuit tester to measure voltage for inspection, never extend forcibly any connector terminals.**



Terminal No. (Wire color)		Description		Condition	Value (Approx.)
		Signal name	Input/ Output		
1 (P)	—	CAN-L	Input/ Output	—	—
2 (L)	—	CAN-H	Input/ Output	—	—
3 (O/L)	Ground	Tire pressure receiver rear RH signal	Input	Ignition switch ON	Standby status  Approx. 4.5 V
					When signal is received  Approx. 4.5 V
4 (L)	Ground	Tire pressure receiver rear LH signal	Input	Ignition switch ON	Standby status  Approx. 4.5 V
					When signal is received  Approx. 4.5 V

A  
B  
C  
D  
E  
F  
G  
H  
I  
J  
K  
L  
M  
N  
O  
P

WT

# LOW TIRE PRESSURE WARNING CONTROL UNIT

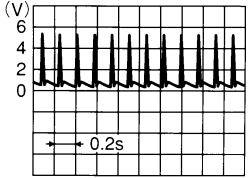
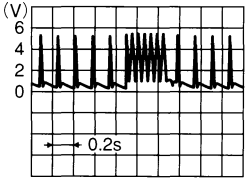
## < ECU DIAGNOSIS INFORMATION >

Terminal No. (Wire color)	Description		Input/ Output	Condition	Value (Approx.)
	Signal name				
5 (R/L)	Ground	Tire pressure receiver front RH signal	Input	Ignition switch ON	 <p style="text-align: center;">Approx. 4.5 V</p>
				When signal is received	 <p style="text-align: center;">Approx. 4.5 V</p>
6 (W/G)	Ground	Tire pressure receiver front LH signal	Input	Ignition switch ON	 <p style="text-align: center;">Approx. 4.5 V</p>
				When signal is received	 <p style="text-align: center;">Approx. 4.5 V</p>
7 (SB)	Ground	Tire pressure receiver rear RH power supply*	Output	Ignition switch ON	Approx. 9 - 16 V
				Ignition switch OFF	0 V
8 (GR)	Ground	Tire pressure receiver rear LH power supply*	Output	Ignition switch ON	Approx. 9 - 16 V
				Ignition switch OFF	0 V
9 (R/W)	Ground	Tire pressure receiver front RH power supply*	Output	Ignition switch ON	Approx. 9 - 16 V
				Ignition switch OFF	0 V
10 (LG)	Ground	Tire pressure receiver front LH power supply*	Output	Ignition switch ON	Approx. 9 - 16 V
				Ignition switch OFF	0 V
15 (GR)	Ground	Power supply	Input	Ignition switch ON	Battery voltage
				Ignition switch OFF	0 V
19 (L/R)	Ground	Tire pressure receiver rear RH signal (sensitivity)	Input	Ignition switch ON	Approx. 0.7 V
				Ignition switch OFF	0 V
20 (P)	Ground	Tire pressure receiver rear LH signal (sensitivity)	Input	Ignition switch ON	Approx. 0.7 V
				Ignition switch OFF	0 V



# LOW TIRE PRESSURE WARNING CONTROL UNIT

## < ECU DIAGNOSIS INFORMATION >

Terminal No. (Wire color)		Description		Condition	Value (Approx.)
		Signal name	Input/ Output		
21 (G/R)	Ground	Tire pressure receiver front RH signal (sensitivity)	Input	Ignition switch ON	Approx. 0.7 V
				Ignition switch OFF	0 V
22 (BR/Y)	Ground	Tire pressure receiver front LH signal (sensitivity)	Input	Ignition switch ON	Approx. 0.7 V
				Ignition switch OFF	0 V
23 (V/W)	Ground	Tire pressure receiver rear RH ground	Input	Always	0 V
24 (R/B)	Ground	Tire pressure receiver rear LH ground	Input	Always	0 V
25 (W/L)	Ground	Tire pressure receiver front RH ground	Input	Always	0 V
26 (BR/W)	Ground	Tire pressure receiver front LH ground	Input	Always	0 V
32 (B)	Ground	Ground	—	Always	0 V

\*: Power is supplied to the tire pressure receiver from the low tire pressure warning control unit.

## DTC Inspection Priority Chart

INFOID:000000009008439

If some DTCs are displayed at the same time, perform inspections one by one based on the following priority chart.

Priority	Detected items (DTC)
1	<ul style="list-style-type: none"> <li>U1000 CAN COMM CIRCUIT</li> <li>U1010 CONTROL UNIT (CAN)</li> </ul>
2	<ul style="list-style-type: none"> <li>C1704 LOW PRESSURE FL</li> <li>C1705 LOW PRESSURE FR</li> <li>C1706 LOW PRESSURE RR</li> <li>C1707 LOW PRESSURE RL</li> </ul>
3	<ul style="list-style-type: none"> <li>C1755 PR RECEIV COND FL</li> <li>C1756 PR RECEIV COND FR</li> <li>C1757 PR RECEIV COND RR</li> <li>C1758 PR RECEIV COND RL</li> </ul>
4	<ul style="list-style-type: none"> <li>C1708 [NO DATA] FL</li> <li>C1709 [NO DATA] FR</li> <li>C1710 [NO DATA] RR</li> <li>C1711 [NO DATA] RL</li> </ul>
5	<ul style="list-style-type: none"> <li>C1716 [PRESSDATA ERR] FL</li> <li>C1717 [PRESSDATA ERR] FR</li> <li>C1718 [PRESSDATA ERR] RR</li> <li>C1719 [PRESSDATA ERR] RL</li> </ul>
7	<ul style="list-style-type: none"> <li>C1728 RECEIVER ID NO REG</li> </ul>
8	<ul style="list-style-type: none"> <li>C1729 VHCL SPEED SIG ERR</li> </ul>
9	<ul style="list-style-type: none"> <li>C1750 [RECEIVER ERR] FL</li> <li>C1751 [RECEIVER ERR] FR</li> <li>C1752 [RECEIVER ERR] RR</li> <li>C1753 [RECEIVER ERR] RL</li> </ul>
10	<ul style="list-style-type: none"> <li>C1754 CONT UNIT (EEPROM)</li> </ul>

# LOW TIRE PRESSURE WARNING CONTROL UNIT

< ECU DIAGNOSIS INFORMATION >

## DTC Index

INFOID:00000009008440

DTC	Items (CONSULT screen terms)	Reference
C1704	LOW PRESSURE FL	<a href="#">WT-30, "DTC Logic"</a>
C1705	LOW PRESSURE FR	
C1706	LOW PRESSURE RR	
C1707	LOW PRESSURE RL	
C1708	[NO DATA] FL	<a href="#">WT-32, "DTC Logic"</a>
C1709	[NO DATA] FR	
C1710	[NO DATA] RR	
C1711	[NO DATA] RL	
C1716	[PRESSDATA ERR] FL	<a href="#">WT-36, "DTC Logic"</a>
C1717	[PRESSDATA ERR] FR	
C1718	[PRESSDATA ERR] RR	
C1719	[PRESSDATA ERR] RL	
C1728	RECEIVER ID NO REG	<a href="#">WT-38, "DTC Logic"</a>
C1729	VHCL SPEED SIG ERR	<a href="#">WT-40, "DTC Logic"</a>
C1750	[RECEIVER ERR] FL	<a href="#">WT-41, "DTC Logic"</a>
C1751	[RECEIVER ERR] FR	
C1752	[RECEIVER ERR] RR	
C1753	[RECEIVER ERR] RL	
C1754	CONT UNIT (EEPROM)	<a href="#">WT-44, "DTC Logic"</a>
C1755	PR RECEIV COND FL	<a href="#">WT-46, "DTC Logic"</a>
C1756	PR RECEIV COND FR	
C1757	PR RECEIV COND RR	
C1758	PR RECEIV COND RL	
U1000	CAN COMM CIRCUIT	<a href="#">WT-48, "DTC Logic"</a>
U1010	CONTROL UNIT (CAN)	<a href="#">WT-49, "DTC Logic"</a>

**NOTE:**

If some DTCs are displayed at the same time, refer to [WT-17, "DTC Inspection Priority Chart"](#).

# TIRE PRESSURE MONITORING SYSTEM

< WIRING DIAGRAM >

## WIRING DIAGRAM

### TIRE PRESSURE MONITORING SYSTEM

#### Wiring Diagram

INFOID:000000009008441

#### TIRE PRESSURE MONITORING SYSTEM

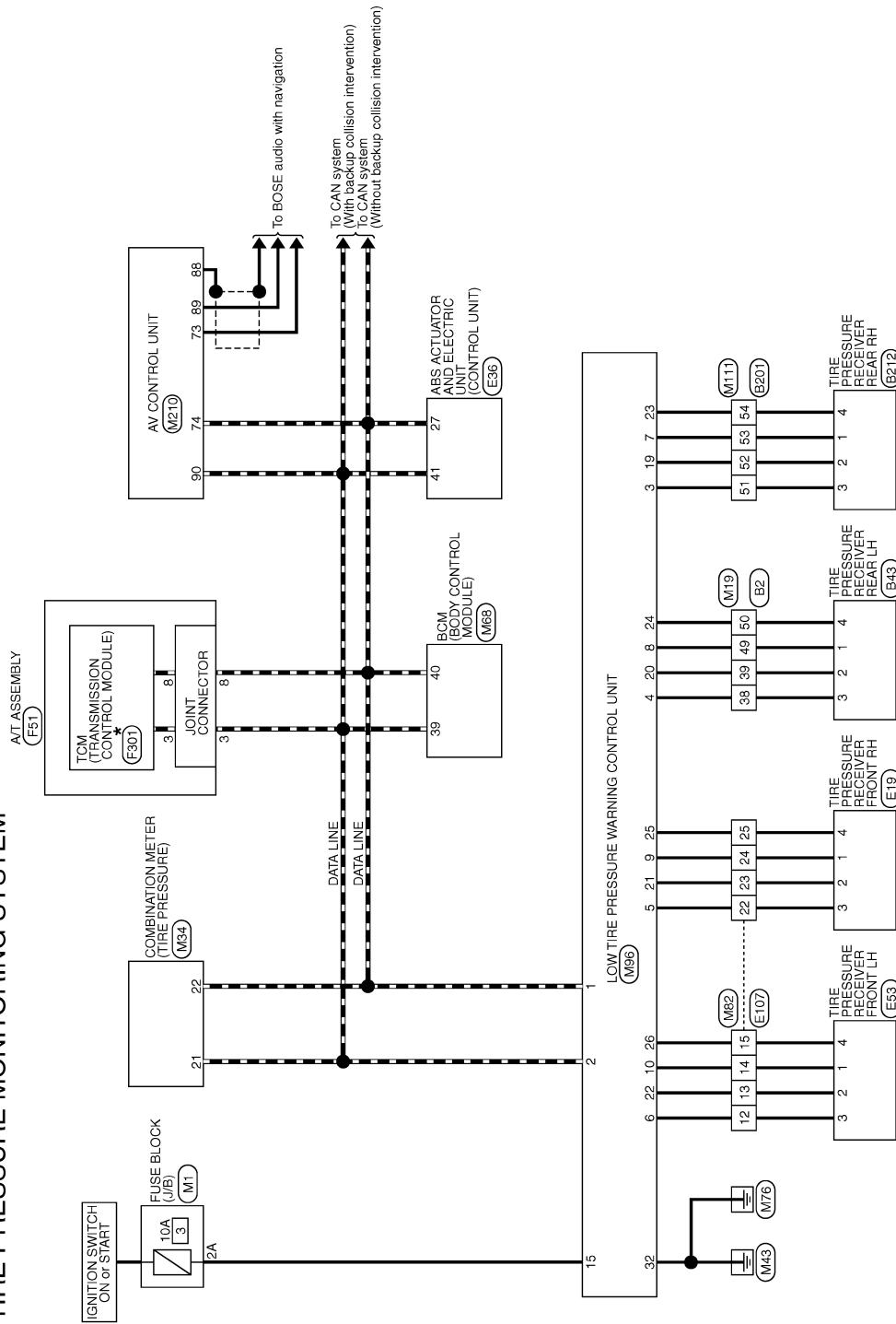

\*: This connector is not shown in "Harness Layout".

2013/01/30

JREW0122GB

A  
B  
C  
D  
WT  
F  
G  
H  
I  
J  
K  
L  
M  
N  
O  
P

# TIRE PRESSURE MONITORING SYSTEM

< WIRING DIAGRAM >

## TIRE PRESSURE MONITORING SYSTEM

Connector No.	B2
Connector Name	WIRE TO WIRE
Connector Type	TH80MW-CS16-TM4

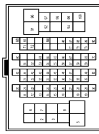

Terminal No.	Color Of Wire	Signal Name [Specification]
2	L	W/B
3	BR	GR/R
5	R/W	GR
6	V	W/R
7	V	W/R
9	G	W/R
11	W/B	GR/R
12	BR	GR/R
13	GR	GR/R
14	B/Y	GR/R
15	W/R	GR/R
16	GR/R	GR/R
18	GW	GR/R
19	V	GR/R
20	W/G	GR/R
21	B/W	GR/R
22	V	GR/R
24	G	GR/R
25	O	GR/R
26	Y	GR/R
27	L/O	GR/R
28	Y/R	GR/R
29	L	GR/R
30	R	GR/R
31	G/Y	GR/R
32	B/SB	GR/R
33	LG/R	GR/R
34	BR/W	GR/R
35	GR/R	GR/R
36	SB	GR/R
37	LG	GR/R
38	L	GR/R
39	P	GR/R
40	W/G	GR/R
41	O	GR/R

42	G/R	GR/R
43	V/W	GR/R
44	LG/B	GR/R
45	R/Y	GR/R
46	B	GR/R
47	BR	GR/R
49	GR	GR/R
50	R/B	GR/R
51	W/R	GR/R
52	B/R	GR/R
53	O/B	GR/R
54	G/O	GR/R
55	R/B	GR/R
56	LG/R	GR/R
57	GR/R	GR/R
58	Y/G	GR/R
59	V/W	GR/R
60	R	GR/R
63	B	GR/R
64	R	GR/R
65	W	GR/R
66	G	GR/R
67	SHIELD	GR/R
69	LG/B	GR/R
70	P/L	GR/R
71	L	GR/R
72	R	GR/R
77	Y/B	GR/R
78	Y/L	GR/R
79	Y	GR/R
80	W/R	GR/R
81	Y/L	GR/R
84	L/O	GR/R
86	O	GR/R
87	W/R	GR/R
88	O	GR/R
89	W/L	GR/R
90	GR/L	GR/R
91	W	GR/R
92	G	GR/R
94	W/R	GR/R
96	L/W	GR/R
97	R	GR/R
98	V	GR/R
99	L/W	GR/R
100	P/B	GR/R

Connector No.	B43
Connector Name	TIRE PRESSURE RECEIVER REAR LH
Connector Type	RH4FB



Terminal No.	Color Of Wire	Signal Name [Specification]
1	GR	RECEIVER+
2	P	RECEIVER PSSI
3	L	RECEIVER SIG
4	R/B	RECEIVER

Connector No.	B201
Connector Name	WIRE TO WIRE
Connector Type	TH80MW-CS16-TM4

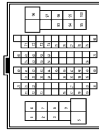

Terminal No.	Color Of Wire	Signal Name [Specification]
1	R/B	GR/R
2	G	GR/R
3	W	GR/R
5	W/B	GR/R
6	L/Y	GR/R
7	R	GR/R
8	GR	GR/R
9	GR/R	GR/R
11	W	GR/R
12	V	GR/R
13	Y	GR/R
16	L/O	GR/R
17	GR/L	GR/R
18	RG	GR/R
19	L/Y	GR/R

20	G/Y	GR/R
21	R	GR/R
22	GR	GR/R
27	L/W	GR/R
29	W	GR/R
30	R/L	GR/R
31	Y/L	GR/R
32	W/R	GR/R
33	W/G	GR/R
34	L/R	GR/R
36	G	GR/R
37	V	GR/R
38	SHIELD	GR/R
39	P/B	GR/R
40	W/R	GR/R
41	R	GR/R
42	L	GR/R
43	B/W	GR/R
44	B	GR/R
45	P	GR/R
46	SHIELD	GR/R
47	R	GR/R
48	W	GR/R
49	SHIELD	GR/R
50	V	GR/R
51	L/B	GR/R
52	L/R	GR/R
53	SB	GR/R
54	V/W	GR/R
59	L	GR/R
60	GR	GR/R
61	P/L	GR/R
62	B/SB	GR/R
63	R/Y	GR/R
64	BR	GR/R
70	O	GR/R
71	W	GR/R
72	SHIELD	GR/R
73	B	GR/R
74	R	GR/R
75	G	GR/R
76	Y	GR/R
77	SB	GR/R
78	LG	GR/R
79	R/B	GR/R
90	W/B	GR/R
93	Y	GR/R
94	L	GR/R
96	L/R	GR/R

JREW0299GB

# TIRE PRESSURE MONITORING SYSTEM

< WIRING DIAGRAM >

## TIRE PRESSURE MONITORING SYSTEM

96	R	-
97	W	-
98	V	-
99	L/W	-
100	W	-

Connector No.	B212
Connector Name	TIRE PRESSURE RECEIVER REAR RH
Connector Type	RHMFB



Terminal No.	Color Of Wire	Signal Name [Specification]
1	SB	RECEIVER+
2	L/R	RECEIVER RSSI
3	L/B	RECEIVER SIG
4	V/W	RECEIVER-

Connector No.	E19
Connector Name	TIRE PRESSURE RECEIVER FRONT RH
Connector Type	RHMFB



Terminal No.	Color Of Wire	Signal Name [Specification]
1	R/W	RECEIVER+
2	G/R	RECEIVER RSSI
3	R/L	RECEIVER SIG
4	W/L	RECEIVER-

Connector No.	E38
Connector Name	ABS ACTUATOR AND ELECTRIC UNIT (CONTROL UNIT)
Connector Type	SAZ4ZFB-SJ24

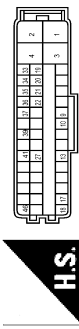

Terminal No.	Color Of Wire	Signal Name [Specification]
1	G	BAT
2	B	GND
3	W	GND
4	W	MOTOR SUPPLY
9	R/B	WAMP INTR. (PUMP) PRESS. SENSOR COMMON (R&L)
10	P/B	WAMP INTR. (PUMP) PRESS. SENSOR COMMON (R&L)
13	GR	WAMP INTR. (PUMP) PRESS. SENSOR COMMON (R&L)
17	L/R	IGN STP2
18	W/B	IGN
19	O	DS FR
20	SB	DP FL
21	RO	DS RR
22	V	DP RL
27	P	CAN-L
33	LG	DP FR
34	G	DS FL
35	BR	DP RR
36	P	DS RL
37	R	STP
39	L/W	VDC OFF SW
41	L	CAN-H
46	W	STOP LAMP SW ON

Connector No.	E53
Connector Name	TIRE PRESSURE RECEIVER FRONT LH
Connector Type	RHMFB



Terminal No.	Color Of Wire	Signal Name [Specification]
1	LG	RECEIVER+
2	BR/Y	RECEIVER RSSI
3	W/G	RECEIVER SIG
4	BR/W	RECEIVER-

Connector No.	E107
Connector Name	WIRE TO WIRE
Connector Type	TH-80MW-GS16-TM4



Terminal No.	Color Of Wire	Signal Name [Specification]
1	L	-
4	V/W	-
5	G/R	-
6	P	-
9	GR/L	-
10	Y/R	-
11	L/R	-
12	W/G	-
13	BR/Y	-
14	L/G	-
15	BR/W	-
16	BY	-
17	W/B	-
18	GR/R	-
20	W/R	-
21	B	-

22	R/L	-
23	G/R	-
24	R/W	-
25	W/L	-
26	R	-
27	L	-
28	G/B	-
35	G	-
36	Y	-
37	R	-
38	G/Y	-
39	O	-
40	W	-
41	R	-
42	B	-
43	G	-
44	SHIELD	-
46	B	-
47	W	-
48	SHIELD	-
49	W	-
50	SHIELD	-
51	Y/R	-
52	GR	-
53	LG/B	-
54	LG/R	-
55	R/G	-
56	B/R	-
57	SB	-
60	G	-
61	B	-
62	W	-
63	R	-
64	SHIELD	-
65	L/Y	-
66	V	-
67	B/W	-
91	G/R	-
95	SB	-
96	G/R	-
97	GR/L	-
98	GW	-
99	R/Y	-
100	L	-

A  
B  
C  
D  
WT  
F  
G  
H  
I  
J  
K  
L  
M  
N  
O  
P

# TIRE PRESSURE MONITORING SYSTEM

< WIRING DIAGRAM >

## TIRE PRESSURE MONITORING SYSTEM

Connector No.	F51
Connector Name	A/T ASSEMBLY
Connector Type	RK10FG



Terminal No.	Color Of Wire	Signal Name [Specification]
1	V	IGNITION POWER SUPPLY
2	P	BATTERY POWER SUPPLY
3	L	CANH
4	SB	KL LINE
5	D	GROUND
6	V	IGNITION POWER SUPPLY
7	R	BACK-UP LAMP RELAY
8	P	CANL
9	BR	STARTER RELAY
10	B	GROUND

Connector No.	F301
Connector Name	TCM (TRANSMISSION CONTROL MODULE)
Connector Type	SP10FG

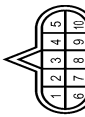

Terminal No.	Color Of Wire	Signal Name [Specification]
1	-	IGNITION POWER SUPPLY
2	-	BATTERY POWER SUPPLY
3	-	CANH
4	-	KL LINE
5	-	GROUND
6	-	IGNITION POWER SUPPLY
7	-	BACK-UP LAMP RELAY
8	-	CANL
9	-	STARTER RELAY
10	-	GROUND

Connector No.	M1
Connector Name	FUSE BLOCK (J/B)
Connector Type	NS08FM-M2

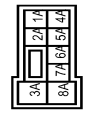

Terminal No.	Color Of Wire	Signal Name [Specification]
1A	Y	-
2A	GR	-
3A	W	-
4A	Y/G	-
5A	V	-
6A	LW	-
7A	LG	-
8A	W	-

Connector No.	M19
Connector Name	WIRE TO WIRE
Connector Type	TH80FM-C5TG-TM4

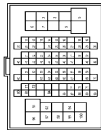

Terminal No.	Color Of Wire	Signal Name [Specification]
2	L	-
3	BR	-
5	RW	-
6	L	-
7	V	-
9	G	-
11	W/B	-
12	BR	-
13	GR	-
14	BY	-
15	WR	-
16	GR/R	-

18	GW	-
19	V	-
20	W/G	-
21	B/W	-
22	V	-
24	G	-
25	O	-
26	Y	-
27	L/O	-
28	Y/R	-
29	L	-
30	R	-
31	G/Y	-
32	B/SB	-
33	LG/R	-
34	BR/W	-
35	GR/R	-
36	SB	-
37	LG	-
38	L	-
39	P	-
40	W/G	-
42	GR	-
43	V/W	-
44	LG/B	-
45	RY	-
46	B	-
47	BR/W	-
49	GR	-
50	R/B	-
51	W/R	-
52	BR/Y	-
53	O/B	-
54	G/O	-
55	R/B	-
56	LG/R	-
57	GR/R	-
58	Y/G	-
59	V/W	-
60	R	-
63	B	-
64	R	-
65	W	-
66	G	-
67	SHIELD	-
69	LG/B	-
70	PL	-
71	PL	-
72	R	-

77	Y/B	-
78	Y/L	-
79	Y	-
80	W/R	-
81	Y/L	-
84	L/O	-
86	O	-
87	W/R	-
88	O	-
89	W/L	-
90	GR/L	-
91	W	-
92	G	-
94	W/R	-
96	L/W	-
97	R	-
98	V	-
89	L/W	-
100	P/B	-

Connector No.	M34
Connector Name	COMBINATION METER
Connector Type	TH40FY-NH



Terminal No.	Color Of Wire	Signal Name [Specification]
1	Y	BATTERY POWER SUPPLY
2	GR	IGNITION SIGNAL
3	B	GROUND
4	B	ILL. GND
5	B	ILL. CONTROL OUTPUT
7	R	TOW MODE SIGNAL
8	P/L	TRIP RESET SWITCH SIGNAL
11	G	ENTER SWITCH SIGNAL
12	O	SELECT SWITCH SIGNAL
13	W/R	ILLUMINATION CONTROL SWITCH SIGNAL (+)
14	R	ILLUMINATION CONTROL SWITCH SIGNAL (-)
15	ROW	AIR BAG SIGNAL
16	W/R	AMBIENT SENSOR SIGNAL
18	V/W	AC/DC WIRE SENSOR SIGNAL
20	B	AMBIENT SENSOR GROUND

# TIRE PRESSURE MONITORING SYSTEM

< WIRING DIAGRAM >

## TIRE PRESSURE MONITORING SYSTEM

Terminal No.	Color Of Wire	Signal Name (Specification)
21	L	CAN-H
22	P	CAN-L
23	B	GROUND
24	V	FUEL LEVEL SENSOR GROUND
25	OIL	ALTERNATOR SIGNAL
26	W	PARKING BRAKE SWITCH SIGNAL
28	GR/R	SECURITY SIGNAL
29	BR	WASHER LEVEL SWITCH SIGNAL
30	SB	VEHICLE SPEED SIGNAL (2-PULSE)
31	BR/W	VEHICLE SPEED SIGNAL (8-PULSE)
33	W	SNOW MODE SIGNAL
34	BR/Y	FUEL LEVEL SENSOR SIGNAL
35	O/B	SEAT BELT BUCKLE SWITCH SIGNAL (DRIVER SEAT)
36	GY	PASSENGER SEAT BELT WARNING SIGNAL
37	R/Y	NON-MANUAL MODE SIGNAL
38	L/W	MANUAL MODE SHIFT DOWN SIGNAL
39	Y/B	MANUAL MODE SHIFT UP SIGNAL
40	GY	MANUAL MODE SIGNAL

Connector No. M68  
 Connector Name BCM (BODY CONTROL MODULE)  
 Connector Type TH40FB-NH

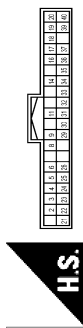

Terminal No.	Color Of Wire	Signal Name (Specification)
2	BR/Y	COMBI SW INPUT 5
3	GR	COMBI SW INPUT 4
4	L	COMBI SW INPUT 3
5	G	COMBI SW INPUT 2
6	V	COMBI SW INPUT 1
8	V	POWER WINDOW SW COMM
9	R	STOP LAMP SW 1
11	R	RAIN SENSOR SERIAL LINK
14	P/B	OPTICAL SENSOR DIMMER SIGNAL
16	L/O	SENSOR PWR SPLY
17	Y/G	RECEIVER PWR SPLY
18	BR	RECEIVER PWR SPLY
19	BR	RECEIVER PWR SPLY
20	G/R	RYLS ENT RECEIVER COMM
21	P	WATS ANT AMP
22	W/B	RYLS ENT RECEIVER RSSI

Terminal No.	Color Of Wire	Signal Name (Specification)
23	GR/R	SECURITY IND CONT
24	SB	DONBLE LINK
25	LG/R	WATS ANT AMP
26	O	INTELLIGENT KEY IDENTIFICATION
29	W	HAZARD SW
30	W/L	BK DOOR OPNR SW
31	W/G	DR DOOR UNLOCK SENSOR
32	LG	COMBI SW OUTPUT 5
33	Y	COMBI SW OUTPUT 4
34	W	COMBI SW OUTPUT 3
35	R/W	COMBI SW OUTPUT 2
36	SB	COMBI SW OUTPUT 1
37	GY	SHIFT P
39	L	CAN-H
40	P	CAN-L

Connector No. M82  
 Connector Name WIRE TO WIRE  
 Connector Type TH80FM-CS16-TM4



Terminal No.	Color Of Wire	Signal Name (Specification)
1	L	-
4	V/W	-
5	G/R	-
6	P	-
9	GR/L	-
10	Y/R	-
11	L/R	-
12	W/G	-
13	BR/Y	-
14	LG	-
15	BR/W	-
16	RY	-
17	W/B	-
18	GR/R	-
20	W/R	-
21	B	-
22	R/L	-
23	GR	-
24	R/W	-

Terminal No.	Color Of Wire	Signal Name (Specification)
25	W/L	-
26	R	-
27	L	-
28	B/SB	-
35	G	-
36	Y	-
37	R	-
38	GY	-
39	O	-
40	W	-
41	R	-
42	B	-
43	G	-
44	SHIELD	-
46	B	-
47	W	-
48	SHIELD	-
49	W	-
50	SHIELD	-
51	Y/R	-
52	GR	-
53	LG/B	-
54	LG/R	-
55	R/G	-
56	BO	-
57	SB	-
60	G	-
61	B	-
62	W	-
63	R	-
64	SHIELD	-
65	L/Y	-
66	V	-
67	B/W	-
91	G/R	-
95	SB	-
96	G/R	-
97	GR/L	-
98	G/W	-
99	P	-
100	L	-

Connector No. M96  
 Connector Name LOW TIRE PRESSURE WARNING CONTROL UNIT  
 Connector Type TH32FM-NH

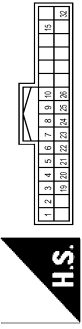

Terminal No.	Color Of Wire	Signal Name (Specification)
1	P	CAN-L
2	L	CAN-H
3	OIL	RR TIRE PRESSURE RECEIVER SIGNAL
4	L	RL TIRE PRESSURE RECEIVER SIGNAL
5	R/L	FR TIRE PRESSURE RECEIVER SIGNAL
6	W/G	FL TIRE PRESSURE RECEIVER SIGNAL
7	SB	RR TIRE PRESSURE RECEIVER POWER SUPPLY
8	R/W	RL TIRE PRESSURE RECEIVER POWER SUPPLY
9	R/W	FR TIRE PRESSURE RECEIVER POWER SUPPLY
10	LG	FL TIRE PRESSURE RECEIVER POWER SUPPLY
15	GR	IGN
19	L/R	RR TIRE PRESSURE RECEIVER SIGNAL (SENSITIVITY)
20	P	RL TIRE PRESSURE RECEIVER SIGNAL (SENSITIVITY)
21	GR	FR TIRE PRESSURE RECEIVER SIGNAL (SENSITIVITY)
22	BR/Y	FL TIRE PRESSURE RECEIVER SIGNAL (SENSITIVITY)
23	V/W	RR TIRE PRESSURE RECEIVER GND
24	R/B	RL TIRE PRESSURE RECEIVER GND
25	W/L	FR TIRE PRESSURE RECEIVER GND
26	BR/W	FL TIRE PRESSURE RECEIVER GND
32	B	GND

A  
B  
C  
D  
WT  
F  
G  
H  
I  
J  
K  
L  
M  
N  
O  
P

# TIRE PRESSURE MONITORING SYSTEM

< WIRING DIAGRAM >

## TIRE PRESSURE MONITORING SYSTEM

Connector No.	M111
Connector Name	WIPE TO WIRE
Connector Type	TH89FW-CS16-TM4



Terminal No.	Color Of Wire	Signal Name [Specification]
1	R/B	-
2	G	-
3	W/R	-
5	W/B	-
6	L/Y	-
7	B	-
8	G/R	-
9	GR/R	-
11	W	-
12	V	-
13	Y	-
16	L/O	-
17	GR/L	-
18	R/G	-
19	L/Y	-
20	G/Y	-
21	R	-
22	GR	-
27	L/O	-
29	SB	-
30	R/L	-
31	Y/L	-
32	W/R	-
33	W/G	-
34	L/R	-
36	G	-
37	V	-
38	SHIELD	-
39	P/B	-
40	W/R	-
41	R	-
42	L/W	-
43	B/W	-
44	B	-
45	B	-
46	SHIELD	-

Terminal No.	Color Of Wire	Signal Name [Specification]
65	W	PARKING BRAKE SIGNAL
67	W	COMPOSITE IMAGE SIGNAL GND
68	R	COMPOSITE IMAGE SIGNAL
69	O	INTELLIGENT KEY IDENTIFICATION SIGNAL
70	BR	REVERSE 12
71	SHIELD	MICROPHONE SHIELD
72	Y	MICROPHONE VCC [With DCM]
72	Y/G	MICROPHONE VCC [Without DCM]
73	Y/G	COMM (CONT-DISP)
74	P	CANH
75	LG	AV COMM (L)
76	LG	AV COMM (L)
79	L/O	DIMMER SIGNAL
80	GR/L	IGNITION SIGNAL
81	R/Y	REVERSE SIGNAL
82	B/W	VEHICLE SPEED SIGNAL (8-PULSE)
83	SHIELD	SHIELD
84	W/B	COMPOSITE IMAGE SYNC SIGNAL
87	GR	MICROPHONE SIGNAL [With DCM]
87	Y/L	MICROPHONE SIGNAL [Without DCM]
88	SHIELD	SHIELD
89	Y/L	COMM (DISP-CONT)
90	L	CANH
91	SB	AV COMM (H)
92	SB	AV COMM (H)

47	R	-
48	W	-
49	SHIELD	-
50	V	-
51	O/L	-
52	L/R	-
53	SB	-
54	V/W	-
59	L	-
60	GR	-
61	P/L	-
62	B/SB	-
63	R/Y	-
64	BR	-
70	O	-
71	W	-
72	SHIELD	-
73	B	-
74	R	-
75	G	-
76	Y	-
77	SB	-
78	LG	-
79	R/B	-
90	W/B	-
93	Y	-
94	L	-
95	L/R	-
96	R	-
97	W	-
98	V	-
99	L/W	-
100	W	-

Connector No.	M210
Connector Name	AV CONTROL UNIT
Connector Type	TH82FW-NH



JREW0303GB



# DIAGNOSIS AND REPAIR WORK FLOW

< BASIC INSPECTION >

## BASIC INSPECTION

### DIAGNOSIS AND REPAIR WORK FLOW

#### Work Flow

INFOID:000000009008442

#### DETAILED FLOW

#### 1. COLLECT THE INFORMATION FROM THE CUSTOMER

It is also important to clarify customer concerns before starting the inspection. Reproduce the symptom, and understand it fully. Interview the customer about the concerns carefully. In some cases, it is necessary to check the symptoms by driving the vehicle with the customer.

**CAUTION:**

**Customers are not professionals. Never assume “maybe the customer means...” or “maybe the customer mentioned this symptom.”**

>> GO TO 2.

#### 2. BASIC INSPECTION

1. Turn the ignition switch ON.

**CAUTION:**

**Never start the engine.**

2. Check the tire pressure for all wheels and adjust to the specified value. Refer to [WT-68. "Tire Air Pressure"](#).

Is the inspection result normal?

YES >> GO TO 3.

NO >> Inspect or repair the tires or wheels.

#### 3. CHECK LOW TIRE PRESSURE WARNING LAMP STATUS

Check low tire pressure warning lamp display.

Does not low tire pressure warning lamp turn OFF?

YES >> GO TO 4.

NO >> GO TO 8.

#### 4. CHECK DTC WITH LOW TIRE PRESSURE WARNING CONTROL UNIT

**With CONSULT**

Perform the self-diagnosis.

Is any DTC detected?

YES >> GO TO 5.

NO >> GO TO 8.

#### 5. ERASE DTC MEMORY

**With CONSULT**

1. Record or print DTC and freeze frame data (FFD).

2. Erase DTC once.

**NOTE:**

After erasing DTC record, currently occurred DTC can be detected by reading out DTC again.

>> GO TO 6.

#### 6. PERFORM DTC CONFIRMATION PROCEDURE

**With CONSULT**

Perform “DTC CONFIRMATION PROCEDURE” (self-diagnosis) with recorded DTC.

If two or more DTCs are detected, refer to [WT-17. "DTC Inspection Priority Chart"](#) and determine trouble diagnosis order.

Is any malfunction detected by self-diagnosis?

YES >> GO TO 7.

A

B

C

D

WT

F

G

H

I

J

K

L

M

N

O

P

# DIAGNOSIS AND REPAIR WORK FLOW

## < BASIC INSPECTION >

---

NO >> GO TO 8.

### 7. DETECT MALFUNCTIONING PART BY DIAGNOSIS PROCEDURE

---

Perform the diagnosis applicable to the displayed DTC. Refer to [WT-18, "DTC Index"](#).

>> GO TO 10.

### 8. CRUISE FOR SYMPTOM CHECK

---

1. Start the engine.
2. Drive for several minutes at a speed of 40 km/h (25 MPH) or more, then stop the vehicle.

>> GO TO 9.

### 9. PERFORM DIAGNOSIS BY SYMPTOM

---

Perform trouble diagnosis or repair applicable to the symptom. Refer to [WT-52, "Symptom Table"](#).

>> GO TO 11.

### 10. FINAL CHECK (WHEN DTC WAS DETECTED)

---

#### With CONSULT

Perform "DTC CONFIRMATION PROCEDURE" (self-diagnosis) with applicable DTC.

Is any malfunction detected by self-diagnosis?

YES >> GO TO 7.

NO >> INSPECTION END

### 11. FINAL CHECK (WHEN SYMPTOM OCCURRED)

---

Make sure that the symptom is not detected.

Does symptom remain?

YES >> GO TO 9.

NO >> INSPECTION END

# ADDITIONAL SERVICE WHEN REPLACING LOW TIRE PRESSURE WARNING CONTROL UNIT

< BASIC INSPECTION >

## ADDITIONAL SERVICE WHEN REPLACING LOW TIRE PRESSURE WARNING CONTROL UNIT

### Description

INFOID:000000009008443

When replacing low tire pressure warning control unit, tire pressure sensor ID registration is required.

### Work Procedure

INFOID:000000009008444

## ADJUST THE NEUTRAL POSITION OF STEERING ANGLE SENSOR

### 1.PERFORM TIRE PRESSURE SENSOR ID REGISTRATION

Perform tire pressure sensor ID registration.

>> Refer to [WT-29, "Work Procedure"](#).

A  
B  
C  
D  
E  
F  
G  
H  
I  
J  
K  
L  
M  
N  
O  
P

WT

# TIRE PRESSURE SENSOR WAKE UP OPERATION

< BASIC INSPECTION >

## TIRE PRESSURE SENSOR WAKE UP OPERATION

### Description

INFOID:000000009008445

When replacing tire pressure sensor, always tire pressure sensor wake-up is required.

### Work Procedure

INFOID:000000009008446

#### 1. TIRE PRESSURE SENSOR WAKE-UP PROCEDURE

1. Turn the ignition switch ON.
2. Press the activation tool (J-45295) (1) against the side of the tire at the location closest to the tire pressure sensor.
3. Wait until the indicator lamp turns OFF (approximately 5 seconds).

**CAUTION:**

Perform the wake-up procedure starting from the vehicle front left wheel, then repeat the procedure in the order of the front right wheel, rear right wheel, and rear left wheel.

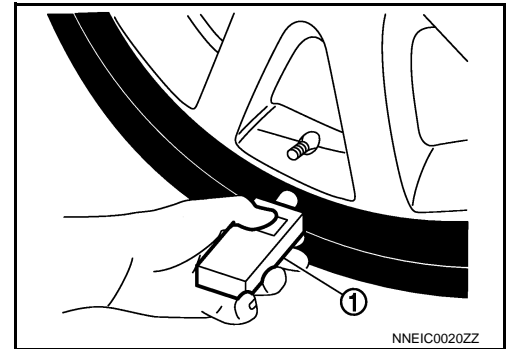

4. Check that the low tire pressure warning lamp blinks in the pattern shown as per the following. The pattern indicates that the tire pressure sensor wake-up procedure for the wheel is completed.

Low tire pressure warning lamp blinking timing		Activation tire position
ON OFF	a : 0.3 sec. b : 1.0 sec.	Front LH
ON OFF	a : 0.3 sec. b : 1.0 sec.	Front RH
ON OFF	a : 0.3 sec. b : 1.0 sec.	Rear RH
ON OFF	a : 0.3 sec. b : 1.0 sec.	Rear LH
ON OFF	a : 2 sec. b : 0.2 sec.	All tires

JPEIC0089GB

5. Check that the hazard warning lamp blink twice when the tire pressure sensor wake-up procedure for all wheels is completed.
6. Check that the low tire pressure warning lamp turns OFF, after the tire pressure sensor wake-up procedure is completed for all wheels and turns OFF.

Is the tire pressure sensor wake-up completed?

- YES >> Perform the tire pressure sensor ID registration procedure. Refer to [WT-29, "Work Procedure"](#).
- NO >> Perform trouble diagnosis for the tire pressure sensor. Refer to [WT-32, "Diagnosis Procedure"](#).

# ID REGISTRATION

< BASIC INSPECTION >

## ID REGISTRATION

### Description

INFOID:000000009008447

When replacing or rotating wheels, replacing tire pressure sensor or low tire pressure warning control unit, always tire pressure sensor ID registration is required.

### Work Procedure

INFOID:000000009008448

#### 1. TIRE PRESSURE SENSOR ID REGISTRATION PROCEDURE

##### CAUTION:

- To perform ID registration, observe the following points:
- Never register ID in a place where radio waves are interfered (e.g. radio tower).
- Never register ID in a place close to vehicles including TPMS.

##### With CONSULT

1. Turn the ignition switch ON.
2. Display the "WORK SUPPORT" screen for "AIR PRESSURE MONITOR" and select "ID REGIST".
3. Press the activation tool (J-45295) (1) against the side of the tire at the location closest to the tire pressure sensor.
4. Wait until the indicator lamp turns OFF (approximately 5 seconds).

##### CAUTION:

Perform the ID registration procedure starting from the vehicle front left wheel, then repeat the procedure in the order of the front right wheel, rear right wheel, and rear left wheel.

5. When ID registration is completed, check the following pattern at each wheel.

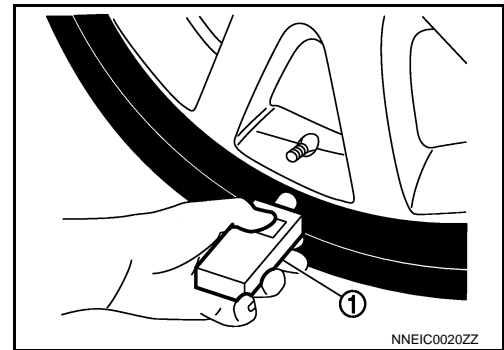

Sequence	ID registration position	Hazard warning lamp	CONSULT
1	Front LH	2 blinks	"Red" ↓ "Green"
2	Front RH		
3	Rear RH		
4	Rear LH		

6. After the ID registration procedure for all wheels is completed, press "End" to end ID registration, and check that ID registration for all wheels is completed.

Is the check result normal?

- YES >> ID registration END.
- NO >> Refer to [WT-59, "Diagnosis Procedure"](#).

A  
B  
C  
D  
WT  
F  
G  
H  
I  
J  
K  
L  
M  
N  
O  
P

# C1704, C1705, C1706, C1707 LOW TIRE PRESSURE

< DTC/CIRCUIT DIAGNOSIS >

## DTC/CIRCUIT DIAGNOSIS

### C1704, C1705, C1706, C1707 LOW TIRE PRESSURE

#### DTC Logic

INFOID:000000009008449

#### DTC DETECTION LOGIC

DTC	Display Item	Malfunction detected condition	Possible causes
C1704	LOW PRESSURE FL	Front LH wheel pressure drops to 189 kPa (1.93 kg/cm <sup>2</sup> , 27.4 psi) or less	Low tire pressure
C1705	LOW PRESSURE FR	Front RH wheel pressure drops to 189 kPa (1.93 kg/cm <sup>2</sup> , 27.4 psi) or less	
C1706	LOW PRESSURE RR	Rear RH wheel pressure drops to 189 kPa (1.93 kg/cm <sup>2</sup> , 27.4 psi) or less	
C1707	LOW PRESSURE RL	Rear LH wheel pressure drops to 189 kPa (1.93 kg/cm <sup>2</sup> , 27.4 psi) or less	

#### DTC CONFIRMATION PROCEDURE

##### 1. PERFORM DTC CONFIRMATION

###### With CONSULT

1. Turn the ignition switch ON.

###### **CAUTION:**

**Never start the engine.**

2. Check the tire pressure for all wheels and adjust to the specified value. Refer to [WT-68, "Tire Air Pressure"](#).
3. Perform self-diagnosis for "AIR PRESSURE MONITOR".

Is DTC "C1704", "C1705", "C1706", or "C1707" detected?

YES >> Proceed to [WT-30, "Diagnosis Procedure"](#).

NO >> INSPECTION END

#### Diagnosis Procedure

INFOID:000000009008450

##### 1. CHECK TIRE PRESSURE

Check the air pressure of all wheels. Refer to [WT-68, "Tire Air Pressure"](#).

Is the inspection result normal?

YES >> Replace the DTC-detected malfunctioning tire pressure sensor. Refer to [WT-65, "Removal and Installation"](#).

NO >> After adjusting the air pressure, GO TO 2.

##### 2. CHECK TIRE PRESSURE SIGNAL

###### With CONSULT

1. Drive for 3 minutes at a speed of 40 km/h (25 MPH) or more, then drive normally for 10 minutes.
2. Stop the vehicle.
3. Select "DATA MONITOR" for "AIR PRESSURE MONITOR" with CONSULT.
4. Within 5 minutes after vehicle stopped, check that the tire pressures match the standard value.

Monitor item	Displayed value
AIR PRESS FL	Approximately equal to the indication on tire gauge value for front LH tire
AIR PRESS FR	Approximately equal to the indication on tire gauge value for front RH tire
AIR PRESS RR	Approximately equal to the indication on tire gauge value for rear RH tire
AIR PRESS RL	Approximately equal to the indication on tire gauge value for rear LH tire

Is the inspection result normal?

YES >> INSPECTION END

# C1704, C1705, C1706, C1707 LOW TIRE PRESSURE

< DTC/CIRCUIT DIAGNOSIS >

---

NO >> Repair or replace error-detected parts.

A

B

C

D

**WT**

F

G

H

I

J

K

L

M

N

O

P

# C1708, C1709, C1710, C1711 TIRE PRESSURE SENSOR

< DTC/CIRCUIT DIAGNOSIS >

## C1708, C1709, C1710, C1711 TIRE PRESSURE SENSOR

### DTC Logic

INFOID:000000009008451

#### DTC DETECTION LOGIC

DTC	Display Item	Malfunction detected condition	Possible causes
C1708	[NO DATA] FL	Tire pressure data signal from the front LH wheel tire pressure sensor cannot be detected.	<ul style="list-style-type: none"> <li>• Harness or connector connection malfunction (Tire pressure receiver, low tire pressure warning control unit)</li> <li>• Tire pressure sensor ID registration incomplete</li> <li>• Tire pressure sensor malfunction</li> <li>• Tire pressure sensor battery voltage</li> </ul>
C1709	[NO DATA] FR	Tire pressure data signal from the front RH wheel tire pressure sensor cannot be detected.	
C1710	[NO DATA] RR	Tire pressure data signal from the rear RH wheel tire pressure sensor cannot be detected.	
C1711	[NO DATA] RL	Tire pressure data signal from the rear LH wheel tire pressure sensor cannot be detected.	

#### DTC CONFIRMATION PROCEDURE

##### 1. PERFORM DTC CONFIRMATION

###### ④ With CONSULT

1. Drive for 3 minutes at a speed of 40 km/h (25 MPH) or more, then drive normally for 10 minutes.
2. Stop the vehicle.
3. Perform self-diagnosis for "AIR PRESSURE MONITOR".

Is DTC "C1708", "C1709", "C1710" or "C1711" detected?

YES >> Proceed to [WT-32, "Diagnosis Procedure"](#).

NO >> INSPECTION END

#### Diagnosis Procedure

INFOID:000000009008452

##### 1. CHECK TIRE PRESSURE SIGNAL

###### ④ With CONSULT

1. Drive for 3 minutes at a speed of 40 km/h (25 MPH) or more, then drive normally for 10 minutes.
2. Stop the vehicle.
3. Select "DATA MONITOR" for "AIR PRESSURE MONITOR" with CONSULT.
4. Within 5 minutes after vehicle stopped, read the values that are displayed for "AIR PRESS FL", "AIR PRESS FR", "AIR PRESS RR", and "AIR PRESS RL".

Are all tire pressures displayed 0 kPa (psi)?

YES >> GO TO 2.

NO >> GO TO 5.

##### 2. CHECK RECEIVER CIRCUIT

1. Turn the ignition switch OFF.
2. Disconnect low tire pressure warning control unit harness connector and tire pressure receiver harness connector.
3. Check the continuity between low tire pressure warning control unit harness connector and tire pressure receiver harness connector.

###### CHECK RECEIVER POWER CIRCUIT

Low tire pressure warning control unit		Tire pressure receiver		Continuity
Connector	Terminal	Connector	Terminal	
M96	10	E53 (Front LH)	1	Existed
	9	E19 (Front RH)		
	8	B43 (Rear LH)		
	7	B212 (Rear RH)		



# C1708, C1709, C1710, C1711 TIRE PRESSURE SENSOR

## < DTC/CIRCUIT DIAGNOSIS >

### CHECK RECEIVER SIGNAL CIRCUIT

Low tire pressure warning control unit		Tire pressure receiver		Continuity
Connector	Terminal	Connector	Terminal	
M96	6	E53 (Front LH)	3	Existed
	5	E19 (Front RH)		
	4	B43 (Rear LH)		
	3	B212 (Rear RH)		

### CHECK RECEIVER SIGNAL (SENSITIVITY) CIRCUIT

Low tire pressure warning control unit		Tire pressure receiver		Continuity
Connector	Terminal	Connector	Terminal	
M96	22	E53 (Front LH)	2	Existed
	21	E19 (Front RH)		
	20	B43 (Rear LH)		
	19	B212 (Rear RH)		

### CHECK RECEIVER GROUND CIRCUIT

Low tire pressure warning control unit		Tire pressure receiver		Continuity
Connector	Terminal	Connector	Terminal	
M96	26	E53 (Front LH)	4	Existed
	25	E19 (Front RH)		
	24	B43 (Rear LH)		
	23	B212 (Rear RH)		

4. Check the continuity between low tire pressure warning control unit harness connector and ground.

### CHECK RECEIVER POWER CIRCUIT

Low tire pressure warning control unit		—	Continuity
Connector	Terminal		
M96	10	Ground	Not existed
	9		
	8		
	7		

### CHECK RECEIVER SIGNAL CIRCUIT

Low tire pressure warning control unit		—	Continuity
Connector	Terminal		
M96	6	Ground	Not existed
	5		
	4		
	3		

### CHECK RECEIVER SIGNAL (SENSITIVITY) CIRCUIT

Low tire pressure warning control unit		—	Continuity
Connector	Terminal		
M96	22	Ground	Not existed
	21		
	20		
	19		

# C1708, C1709, C1710, C1711 TIRE PRESSURE SENSOR

## < DTC/CIRCUIT DIAGNOSIS >

### CHECK RECEIVER GROUND CIRCUIT

Low tire pressure warning control unit		—	Continuity
Connector	Terminal		
M96	26	Ground	Not existed
	25		
	24		
	23		

Is the inspection result normal?

YES >> GO TO 3.

NO >> Repair or replace the malfunctioning harness or connector.

### 3. CHECK TIRE PRESSURE RECEIVER POWER SUPPLY CIRCUIT

1. Connect low tire pressure warning control unit harness connector.
2. Turn the ignition switch ON.

**CAUTION:**

**Never start the engine.**

3. Check the voltage between tire pressure receiver harness connector and ground.

Tire pressure receiver		—	Voltage
Connector	Terminal		
E53 (Front LH)	1	Ground	Approx. 9 - 16 V
E19 (Front RH)			
B43 (Rear LH)			
B212 (Rear RH)			

Is the inspection result normal?

YES >> GO TO 4.

NO >> Replace the low tire pressure warning control unit. Refer to [WT-64, "Removal and Installation"](#).

### 4. TIRE PRESSURE RECEIVER SIGNAL

Check tire pressure receiver signal. Refer to [WT-41, "Diagnosis Procedure"](#).

Is the inspection result normal?

YES >> GO TO 5.

NO >> Repair or replace error-detected parts.

### 5. TIRE PRESSURE SENSOR ID REGISTRATION

Perform tire pressure sensor ID registration. Refer to [WT-29, "Work Procedure"](#).

Is tire pressure sensor ID registration completed?

YES >> GO TO 6.

NO >> Replace applicable tire pressure sensor. Refer to [WT-65, "Removal and Installation"](#).

### 6. CHECK TIRE PRESSURE SIGNAL

#### Ⓢ With CONSULT

1. Drive for 3 minutes at a speed of 40 km/h (25 MPH) or more, then drive normally for 10 minutes.
2. Stop the vehicle.
3. Select "DATA MONITOR" for "AIR PRESSURE MONITOR" with CONSULT.
4. Within 15 minutes after vehicle stopped, check that the tire pressures match the standard value.

Monitor item	Displayed value
AIR PRESS FL	Approximately equal to the indication on tire gauge value for front LH tire
AIR PRESS FR	Approximately equal to the indication on tire gauge value for front RH tire
AIR PRESS RR	Approximately equal to the indication on tire gauge value for rear RH tire
AIR PRESS RL	Approximately equal to the indication on tire gauge value for rear LH tire

Is the inspection result normal?

# C1708, C1709, C1710, C1711 TIRE PRESSURE SENSOR

## < DTC/CIRCUIT DIAGNOSIS >

---

YES >> INSPECTION END

NO >> Replace the low tire pressure warning control unit. Refer to [WT-64, "Removal and Installation"](#).

A

B

C

D

WT

F

G

H

I

J

K

L

M

N

O

P

# C1716, C1717, C1718, C1719 TIRE PRESSURE SENSOR

< DTC/CIRCUIT DIAGNOSIS >

## C1716, C1717, C1718, C1719 TIRE PRESSURE SENSOR

### DTC Logic

INFOID:000000009008453

### DTC DETECTION LOGIC

DTC	Display Item	Malfunction detected condition	Possible causes
C1716	[PRESSDATA ERR] FL	Malfunction in the tire pressure data from the front LH wheel tire pressure sensor. <b>NOTE:</b> In this case the low tire pressure warning control unit judges that the tire pressure is 438.60 kPa (4.47 kg/cm <sup>2</sup> , 63.60 psi).	<ul style="list-style-type: none"> <li>Tire pressure sensor ID registration incomplete</li> <li>Tire pressure sensor malfunction</li> </ul>
C1717	[PRESSDATA ERR] FR	Malfunction in the tire pressure data from the front RH wheel tire pressure sensor. <b>NOTE:</b> In this case the low tire pressure warning control unit judges that the tire pressure is 438.60 kPa (4.47 kg/cm <sup>2</sup> , 63.60 psi).	
C1718	[PRESSDATA ERR] RR	Malfunction in the tire pressure data from the rear RH wheel tire pressure sensor. <b>NOTE:</b> In this case the low tire pressure warning control unit judges that the tire pressure is 438.60 kPa (4.47 kg/cm <sup>2</sup> , 63.60 psi).	
C1719	[PRESSDATA ERR] RL	Malfunction in the tire pressure data from the rear LH wheel tire pressure sensor. <b>NOTE:</b> In this case the low tire pressure warning control unit judges that the tire pressure is 438.60 kPa (4.47 kg/cm <sup>2</sup> , 63.60 psi).	

### DTC CONFIRMATION PROCEDURE

#### 1. PERFORM DTC CONFIRMATION

##### With CONSULT

- Turn the ignition switch ON.

##### **CAUTION:**

**Never start the engine.**

- Check the tire pressure for all wheels and adjust to the specified value. Refer to [WT-68, "Tire Air Pressure"](#).
- Perform self-diagnosis for "AIR PRESSURE MONITOR".

Is DTC "C1716", "C1717", "C1718", or "C1719" detected?

YES >> Proceed to [WT-36, "Diagnosis Procedure"](#).

NO >> INSPECTION END

### Diagnosis Procedure

INFOID:000000009008454

#### 1. CHECK TIRE PRESSURE

Check the air pressure of all wheels. Refer to [WT-68, "Tire Air Pressure"](#).

Is the inspection result normal?

YES >> Replace the DTC-detected malfunctioning tire pressure sensor. Refer to [WT-65, "Removal and Installation"](#).

NO >> After adjusting the air pressure, GO TO 2.

#### 2. CHECK TIRE PRESSURE SIGNAL

##### With CONSULT

# C1716, C1717, C1718, C1719 TIRE PRESSURE SENSOR

## < DTC/CIRCUIT DIAGNOSIS >

1. Check the tire pressure for all wheels and adjust to the specified value. Refer to [WT-68. "Tire Air Pressure"](#). A
2. Perform tire pressure sensor ID registration for all wheels. Refer to [WT-29. "Work Procedure"](#).
3. Drive for 3 minutes at a speed of 40 km/h (25 MPH) or more, then drive normally for 10 minutes.
4. Stop the vehicle.
5. Select "DATA MONITOR" for "AIR PRESSURE MONITOR" with CONSULT. B
6. Within 15 minutes after vehicle stopped, read the values that are displayed for "AIR PRESS FL", "AIR PRESS FR", "AIR PRESS RR", and "AIR PRESS RL". C

Which tire pressures is displayed as 438.60 kPa (4.47 kg/cm<sup>2</sup>, 63.60 psi)?

- YES >> Replace tire pressure sensor the tire pressure as 438.60 kPa (4.47 kg/cm<sup>2</sup>, 63.60 psi) displayed. Refer to [WT-65. "Removal and Installation"](#). D
- NO >> Perform "DTC CONFIRMATION PROCEDURE" (self-diagnosis) again. Refer to [WT-36. "DTC Logic"](#).

WT

F

G

H

I

J

K

L

M

N

O

P

# C1728 RECEIVER ID

< DTC/CIRCUIT DIAGNOSIS >

## C1728 RECEIVER ID

### DTC Logic

INFOID:000000009008455

### DTC DETECTION LOGIC

DTC	Display Item	Malfunction detected condition	Possible causes
C1728	RECEIVER ID NO REG	Receiver ID registration cannot be performed.	<ul style="list-style-type: none"> <li>Tire pressure receiver malfunction</li> <li>Low tire pressure warning control unit malfunction</li> </ul>

### DTC CONFIRMATION PROCEDURE

#### 1. PERFORM DTC CONFIRMATION

##### With CONSULT

- Drive for 3 minutes at a speed of 40 km/h (25 MPH) or more, then drive normally for 10 minutes.
- Stop the vehicle.
- Perform self-diagnosis for "AIR PRESSURE MONITOR".

##### Is DTC "C1728" detected?

- YES >> Proceed to [WT-38, "Diagnosis Procedure"](#).  
 NO >> INSPECTION END

### Diagnosis Procedure

INFOID:000000009008456

#### 1. CHECK TIRE PRESSURE RECEIVER INPUT SIGNAL

- Turn the ignition switch ON.

##### **CAUTION:**

**Never start engine.**

- Use an oscilloscope and check the input signal waveform between the low tire pressure warning control unit harness connector and ground.

##### STANDBY STATUS

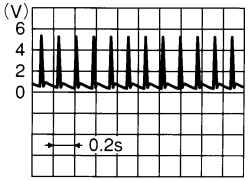
Low tire pressure warning control unit		—	Value (Approx.)
Connector	Terminal		
M96	3	Ground	 <p>Approx. 4.5 V</p>
	4		
	5		
	6		

##### WHEN SIGNAL IS RECEIVED

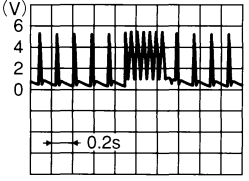
Low tire pressure warning control unit		—	Value (Approx.)
Connector	Terminal		
M96	3	Ground	 <p>Approx. 4.5 V</p>
	4		
	5		
	6		

##### Is the inspection result normal?

# C1728 RECEIVER ID

## < DTC/CIRCUIT DIAGNOSIS >

- YES >> Check connector for loose connection and then perform "DTC CONFIRMATION PROCEDURE" (self-diagnosis) again. Refer to [WT-38, "DTC Logic"](#).
- NO >> GO TO 2.

### 2.CHECK TIRE PRESSURE RECEIVER POWER SUPPLY CIRCUIT

1. Disconnect the tire pressure receiver harness connector.
2. Turn the ignition switch ON.  
**CAUTION:**  
**Never start the engine.**
3. Check the voltage between tire pressure receiver harness connector and ground.

Tire pressure receiver		—	Voltage
Connector	Terminal		
E53 (Front LH)	1	Ground	Approx. 9 - 16 V
E19 (Front RH)			
B43 (Rear LH)			
B212 (Rear RH)			

Is the inspection result normal?

- YES >> GO TO 3.
- NO >> Repair or replace the malfunctioning harness or connector.

### 3.CHECK TIRE PRESSURE RECEIVER GROUND CIRCUIT

1. Turn the ignition switch OFF.
2. Disconnect low tire pressure warning control unit harness connector and tire pressure receiver harness connector.
3. Check the continuity between low tire pressure warning control unit harness connector and tire pressure receiver harness connector.

Low tire pressure warning control unit		Tire pressure receiver		Continuity
Connector	Terminal	Connector	Terminal	
M96	26	E53 (Front LH)	4	Existed
	25	E19 (Front RH)		
	24	B43 (Rear LH)		
	23	B212 (Rear RH)		

Is the inspection result normal?

- YES >> GO TO 4.
- NO >> Repair or replace the malfunctioning harness or connector.

### 4.CHECK LOW TIRE PRESSURE WARNING CONTROL UNIT CIRCUIT

Check the low tire pressure warning control unit circuit. Refer to [WT-44, "Diagnosis Procedure"](#).

Is the low tire pressure warning control unit circuit normal?

- YES >> Replace the tire pressure receiver. Refer to [WT-67, "FRONT TIRE PRESSURE RECEIVER : Removal and Installation"](#) (Front), [WT-67, "REAR TIRE PRESSURE RECEIVER : Removal and Installation"](#) (Rear).
- NO >> Repair or replace error-detected parts.

# C1729 VEHICLE SPEED SIGNAL

< DTC/CIRCUIT DIAGNOSIS >

## C1729 VEHICLE SPEED SIGNAL

### DTC Logic

INFOID:000000009008457

### DTC DETECTION LOGIC

DTC	Display Item	Malfunction detected condition	Possible causes
C1729	VHCL SPEED SIG ERR	Vehicle speed signal not detected.	<ul style="list-style-type: none"><li>• CAN communication malfunction</li><li>• Low tire pressure warning control unit malfunction</li><li>• ABS actuator and electric unit (control unit) malfunction</li></ul>

### DTC CONFIRMATION PROCEDURE

#### 1. DTC CONFIRMATION PROCEDURE

##### With CONSULT

1. Drive for 3 minutes at a speed of 40 km/h (25 MPH) or more without stopping.
2. Stop the vehicle.
3. Perform self-diagnosis for "AIR PRESSURE MONITOR".

##### Is DTC "C1729" detected?

- YES >> Proceed to [WT-40, "Diagnosis Procedure"](#).  
NO >> INSPECTION END

### Diagnosis Procedure

INFOID:000000009008458

#### 1. PERFORM ABS ACTUATOR AND ELECTRIC UNIT (CONTROL UNIT) SELF-DIAGNOSIS

##### With CONSULT

Perform self-diagnosis for "ABS".

##### Is any DTC detected?

- YES >> Check malfunctioning circuit.  
NO >> GO TO 2.

#### 2. PERFORM SELF-DIAGNOSIS AGAIN

##### With CONSULT

Perform "DTC CONFIRMATION PROCEDURE" (self-diagnosis) again. Refer to [WT-40, "DTC Logic"](#).

##### Is DTC "C1729" detected?

- YES >> Replace the low tire pressure warning control unit. Refer to [WT-64, "Removal and Installation"](#).  
NO >> GO TO 3.

#### 3. CHECK LOW TIRE PRESSURE WARNING CONTROL UNIT INPUT/OUTPUT SIGNAL

Check the low tire pressure warning control unit input/output signal values. Refer to [WT-14, "Reference Value"](#).

##### Is the inspection result normal?

- YES >> Check pin terminal and connection of each harness connector for malfunctioning conditions.  
NO >> Replace the low tire pressure warning control unit. Refer to [WT-64, "Removal and Installation"](#).



# C1750, C1751, C1752, C1753 RECEIVER

< DTC/CIRCUIT DIAGNOSIS >

## C1750, C1751, C1752, C1753 RECEIVER

### DTC Logic

INFOID:000000009008459

### DTC DETECTION LOGIC

DTC	Display Item	Malfunction detected condition	Possible causes
C1750	[RECEIVER ERR] FL	The front LH tire pressure receiver dose not receive a signal.	Tire pressure receiver malfunction
C1751	[RECEIVER ERR] FR	The front RH tire pressure receiver dose not receive a signal.	
C1752	[RECEIVER ERR] RR	The rear RH tire pressure receiver dose not receive a signal.	
C1753	[RECEIVER ERR] RL	The rear LH tire pressure receiver dose not receive a signal.	

### DTC CONFIRMATION PROCEDURE

#### 1. PERFORM DTC CONFIRMATION

##### With CONSULT

1. Drive for 3 minutes at a speed of 40 km/h (25 MPH) or more, then drive normally for 10 minutes.
2. Stop the vehicle.
3. Perform self-diagnosis for "AIR PRESSURE MONITOR".

Is DTC "C1750", "C1751", "C1752", or "C1753" detected?

- YES >> Proceed to [WT-41, "Diagnosis Procedure"](#).  
 NO >> INSPECTION END

### Diagnosis Procedure

INFOID:000000009008460

#### 1. CHECK TIRE PRESSURE RECEIVER INPUT SIGNAL

1. Turn the ignition switch ON.

##### CAUTION:

**Never start engine.**

2. Use an oscilloscope and check the input signal waveform between the low tire pressure warning control unit harness connector and ground.

#### STANDBY STATUS

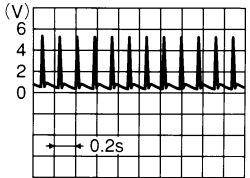
Low tire pressure warning control unit		—	Value (Approx.)
Connector	Terminal		
M96	3	Ground	 <p>OCC3879D Approx. 4.5 V</p>
	4		
	5		
	6		

# C1750, C1751, C1752, C1753 RECEIVER

## < DTC/CIRCUIT DIAGNOSIS >

### WHEN SIGNAL IS RECEIVED

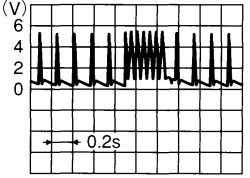
Low tire pressure warning control unit		—	Value (Approx.)
Connector	Terminal		
M96	3	Ground	
	4		
	5		
	6		

#### Is the inspection result normal?

- YES >> Check connector for loose connection and then perform "DTC CONFIRMATION PROCEDURE" (self-diagnosis) again. Refer to [WT-41, "DTC Logic"](#).
- NO >> GO TO 2.

### 2. CHECK TIRE PRESSURE RECEIVER POWER SUPPLY CIRCUIT

1. Disconnect the tire pressure receiver harness connector.
  2. Turn the ignition switch ON.
- CAUTION:**  
**Never start the engine.**
3. Check the voltage between tire pressure receiver harness connector and ground.

Tire pressure receiver		—	Voltage
Connector	Terminal		
E53 (Front LH)	1	Ground	Approx. 9 - 16 V
E19 (Front RH)			
B43 (Rear LH)			
B212 (Rear RH)			

#### Is the inspection result normal?

- YES >> GO TO 3.
- NO >> Repair or replace the malfunctioning harness or connector.

### 3. CHECK TIRE PRESSURE RECEIVER GROUND CIRCUIT

1. Turn the ignition switch OFF.
2. Disconnect low tire pressure warning control unit harness connector and tire pressure receiver harness connector.
3. Check the continuity between low tire pressure warning control unit harness connector and tire pressure receiver harness connector.

Low tire pressure warning control unit		Tire pressure receiver		Continuity
Connector	Terminal	Connector	Terminal	
M96	26	E53 (Front LH)	4	Existed
	25	E19 (Front RH)		
	24	B43 (Rear LH)		
	23	B212 (Rear RH)		

#### Is the inspection result normal?

- YES >> GO TO 4.
- NO >> Repair or replace the malfunctioning harness or connector.

### 4. CHECK FOR CHANGE TO THE TIRE PRESSURE RECEIVER INSTALLATION POSITION (EXAMPLE: FRONT LH RECEIVER OK/NG JUDGMENT)

**NOTE:**

Example: Front LH tire pressure receiver OK/NG judgment when DTC "C1750" is detected.

## C1750, C1751, C1752, C1753 RECEIVER

### < DTC/CIRCUIT DIAGNOSIS >

---

#### With CONSULT

1. Exchange the positions of the front LH tire pressure receiver and the front RH tire pressure receiver.
2. Perform "DTC CONFIRMATION PROCEDURE" (self-diagnosis) again. Refer to [WT-41, "DTC Logic"](#).

#### Is DTC "C1751" detected?

- YES >> Replace the exchanged front RH tire pressure receiver.
- NO >> Check the low tire pressure warning control unit circuit. Refer to [WT-44, "Diagnosis Procedure"](#).

A  
B  
C  
D  
WT  
F  
G  
H  
I  
J  
K  
L  
M  
N  
O  
P

# C1754 LOW TIRE PRESSURE WARNING CONTROL UNIT

< DTC/CIRCUIT DIAGNOSIS >

## C1754 LOW TIRE PRESSURE WARNING CONTROL UNIT

### DTC Logic

INFOID:000000009008461

### DTC DETECTION LOGIC

DTC	Display Item	Malfunction detected condition	Possible causes
C1754	CONT UNIT (EEPROM)	Memory (EEPROM) system malfunction is detected in the low tire pressure warning control unit	Low tire pressure warning control unit malfunction

### DTC CONFIRMATION PROCEDURE

#### 1. PERFORM DTC CONFIRMATION

##### With CONSULT

1. Drive for 3 minutes at a speed of 40 km/h (25 MPH) or more without stopping.
2. Stop the vehicle.
3. Perform self-diagnosis for "AIR PRESSURE MONITOR".

##### Is DTC "C1754" detected?

- YES >> Proceed to [WT-44, "Diagnosis Procedure"](#).  
 NO >> INSPECTION END

### Diagnosis Procedure

INFOID:000000009008462

#### 1. CHECK LOW TIRE PRESSURE WARNING CONTROL UNIT POWER SUPPLY AND GROUND CIRCUIT

Perform the trouble diagnosis for power supply and ground circuit. Refer to [WT-50, "Diagnosis Procedure"](#).

##### Is the inspection result normal?

- YES >> GO TO 2.  
 NO >> Repair or replace error-detected parts.

#### 2. CHECK TIRE PRESSURE RECEIVER CIRCUIT

1. Disconnect the tire pressure receiver harness connector.
2. Check the continuity between the low tire pressure warning control unit harness connector and tire pressure receiver harness connector.

Low tire pressure warning control unit		Tire pressure receiver		Continuity
Connector	Terminal	Connector	Terminal	
M96	6	E53 (Front LH)	3	Existed
	22		2	
	10		1	
	26		4	
	5	E19 (Front RH)	3	
	21		2	
	9		1	
	25		4	
	4	B43 (Rear LH)	3	
	20		2	
	8		1	
	24		4	
	3	B212 (Rear RH)	3	
	19		2	
	7		1	
	23		4	

# C1754 LOW TIRE PRESSURE WARNING CONTROL UNIT

## < DTC/CIRCUIT DIAGNOSIS >

3. Check the continuity between the low tire pressure warning control unit harness connector and ground.

Low tire pressure warning control unit		—	Continuity
Connector	Terminal		
M96	6	Ground	Not existed
	22		
	10		
	26		
	5		
	21		
	9		
	25		
	4		
	20		
	8		
	24		
	3		
	19		
	7		
23			

Is the inspection result normal?

YES >> GO TO 3.

NO >> Repair or replace the malfunctioning harness or connector.

### 3. PERFORM SELF-DIAGNOSIS AGAIN

#### With CONSULT

1. Check the tire pressure for all wheels and adjust to the specified value. Refer to [WT-68. "Tire Air Pressure"](#).
2. Perform tire pressure sensor ID registration for all wheels. Refer to [WT-29. "Work Procedure"](#).
3. Perform "DTC CONFIRMATION PROCEDURE" (self-diagnosis) again. Refer to [WT-44. "DTC Logic"](#).

Is DTC "C1754" detected?

YES >> Replace the low tire pressure warning control unit. Refer to [WT-64. "Removal and Installation"](#).

NO >> Check for looseness or damage at the harness connector pins of the low tire pressure warning control unit. Repair or replace if necessary.

# C1755, C1756, C1757, C1758 POOR RECEIVING CONDITIONS

< DTC/CIRCUIT DIAGNOSIS >

## C1755, C1756, C1757, C1758 POOR RECEIVING CONDITIONS

### DTC Logic

INFOID:000000009008463

### DTC DETECTION LOGIC

DTC	Display Item	Malfunction detected condition	Possible causes
C1755	PR RECEIV COND FL	The data signal from the front LH wheel tire pressure sensor cannot be detected due to external electromagnetic interference for 10 minutes or more. (DTC C1708 is displayed at the same time.)	External electromagnetic interference
C1756	PR RECEIV COND FR	The data signal from the front RH wheel tire pressure sensor cannot be detected due to external electromagnetic interference for 10 minutes or more. (DTC C1709 is displayed at the same time.)	
C1757	PR RECEIV COND RR	The data signal from the rear RH wheel tire pressure sensor cannot be detected due to external electromagnetic interference for 10 minutes or more. (DTC C1710 is displayed at the same time.)	
C1758	PR RECEIV COND RL	The data signal from the rear LH wheel tire pressure sensor cannot be detected due to external electromagnetic interference for 10 minutes or more. (DTC C1711 is displayed at the same time.)	

### CAUTION:

If DTC C1755, C1756, C1757, or C1758 is detected along with, C1708, C1709, C1710, or C1711 first diagnose C1755, C1756, C1757, or C1758.

### DTC CONFIRMATION PROCEDURE

#### 1. PERFORM DTC CONFIRMATION

#### ④ With CONSULT

1. Drive for 3 minutes at a speed of 40 km/h (25 MPH) or more, then drive normally for 10 minutes.
2. Stop the vehicle.
3. Perform self-diagnosis for "AIR PRESSURE MONITOR".

Is DTC "C1755", "C1756", "C1757", or "C1758" detected?

YES >> Proceed to [WT-46. "Diagnosis Procedure"](#).

NO >> INSPECTION END

### Diagnosis Procedure

INFOID:000000009008464

#### 1. TIRE PRESSURE SENSOR ID REGISTRATION

Perform tire pressure sensor ID registration. Refer to [WT-29. "Work Procedure"](#).

Is tire pressure sensor ID registration completed?

YES >> GO TO 2.

NO >> Change the work location and perform ID registration again, then proceed to [WT-59. "Diagnosis Procedure"](#).

#### 2. CHECK TIRE PRESSURE SIGNAL

#### ④ With CONSULT

1. Drive for 3 minutes at a speed of 40 km/h (25 MPH) or more, then drive normally for 10 minutes.
2. Stop the vehicle.
3. Select "DATA MONITOR" for "AIR PRESSURE MONITOR" with CONSULT.
4. Within 5 minutes after vehicle stopped, check that the tire pressures match the standard value.

Monitor item	Displayed value
AIR PRESS FL	Approximately equal to the indication on tire gauge value for front LH tire
AIR PRESS FR	Approximately equal to the indication on tire gauge value for front RH tire

# C1755, C1756, C1757, C1758 POOR RECEIVING CONDITIONS

## < DTC/CIRCUIT DIAGNOSIS >

Monitor item	Displayed value
AIR PRESS RR	Approximately equal to the indication on tire gauge value for rear RH tire
AIR PRESS RL	Approximately equal to the indication on tire gauge value for rear LH tire

Is the inspection result normal?

YES >> GO TO 3.

NO >> Change the work location, then GO TO 1.

### 3. CHECK SELF-DIAGNOSIS RESULTS

#### With CONSULT

1. Erase the self-diagnosis memory for the low tire pressure warning control unit.
2. Turn ignition switch OFF, and wait for 10 seconds or more.
3. Perform "DTC CONFIRMATION PROCEDURE" (self-diagnosis) again. Refer to [WT-46, "DTC Logic"](#).

Are DTC "C1755", "C1756", "C1757", or "C1758" and "C1708", "C1709", "C1710", or "C1711" detected?

YES >> Change the work location, then GO TO 1.

NO >> Check the input/output signal values. Refer to [WT-14, "Reference Value"](#).

A  
B  
C  
D  
WT  
F  
G  
H  
I  
J  
K  
L  
M  
N  
O  
P

# U1000 CAN COMM CIRCUIT

< DTC/CIRCUIT DIAGNOSIS >

## U1000 CAN COMM CIRCUIT

### Description

INFOID:000000009008465

CAN (Controller Area Network) is a serial communication line for real time application. It is an on-vehicle multiplex communication line with high data communication speed and excellent error detection ability. Many electronic control units are equipped onto a vehicle, and each control unit shares information and links with other control units during operation (not independent). In CAN communication, control units are connected with 2 communication lines (CAN-H line, CAN-L line) allowing a high rate of information transmission with less wiring. Each control unit communicates data but selectively reads required data only.

### DTC Logic

INFOID:000000009008466

### DTC DETECTION LOGIC

DTC	Display item	Malfunction detected condition	Possible cause
U1000	CAN COMM CIRCUIT	Low tire pressure warning control unit is not communicating CAN communication signal for 2 seconds or more.	<ul style="list-style-type: none"><li>• CAN communication malfunction</li><li>• Malfunction of low tire pressure warning control unit</li></ul>

### DTC CONFIRMATION PROCEDURE

#### 1. PERFORM DTC CONFIRMATION

##### ④ With CONSULT

1. Drive for several minutes at a speed of 40 km/h (25 MPH) or more.
2. Stop the vehicle.
3. Perform self-diagnosis for "AIR PRESSURE MONITOR".

Is DTC "U1000" detected?

- YES >> Proceed to [WT-48, "Diagnosis Procedure"](#).  
NO >> INSPECTION END

### Diagnosis Procedure

INFOID:000000009008467

Proceed to [LAN-31, "CAN COMMUNICATION SYSTEM : CAN System Specification Chart"](#).



# U1010 CONTROL UNIT (CAN)

< DTC/CIRCUIT DIAGNOSIS >

## U1010 CONTROL UNIT (CAN)

### Description

INFOID:000000009008468

CAN (Controller Area Network) is a serial communication line for real time application. It is an on-vehicle multiplex communication line with high data communication speed and excellent error detection ability. Many electronic control units are equipped onto a vehicle, and each control unit shares information and links with other control units during operation (not independent). In CAN communication, control units are connected with 2 communication lines (CAN-H line, CAN-L line) allowing a high rate of information transmission with less wiring. Each control unit communicates data but selectively reads required data only.

### DTC Logic

INFOID:000000009008469

### DTC DETECTION LOGIC

DTC	Display item	Malfunction detected condition	Possible cause
U1010	CONTROL UNIT (CAN)	Detecting error during the initial diagnosis of CAN controller of low tire pressure warning control unit.	Malfunction of low tire pressure warning control unit

### DTC CONFIRMATION PROCEDURE

#### 1. PERFORM DTC CONFIRMATION

##### With CONSULT

1. Drive for several minutes at a speed of 40 km/h (25 MPH) or more.
2. Stop the vehicle.
3. Perform self-diagnosis for "AIR PRESSURE MONITOR".

Is DTC "U1010" detected?

- YES >> Proceed to [WT-49, "Diagnosis Procedure"](#).  
NO >> INSPECTION END

### Diagnosis Procedure

INFOID:000000009008470

#### 1. CHECK LOW TIRE PRESSURE WARNING CONTROL UNIT

Check low tire pressure warning control unit harness connector for disconnection or deformation.

Is the inspection result normal?

- YES >> Replace low tire pressure warning control unit. Refer to [WT-64, "Removal and Installation"](#).  
NO >> Repair or replace error-detected parts.

# POWER SUPPLY AND GROUND CIRCUIT

< DTC/CIRCUIT DIAGNOSIS >

## POWER SUPPLY AND GROUND CIRCUIT

### Diagnosis Procedure

INFOID:000000009008471

#### 1. CHECK FUSE/FUSIBLE LINK

1. Turn the ignition switch OFF.
2. Check for fusing of the fuse and fusible link at the low tire pressure warning control unit.
  - Check the 10 A fuse [No. 3 in fuse block (J/B)]

Is the inspection result normal?

- YES >> GO TO 2.  
NO >> Repair or replace error-detected parts.

#### 2. CHECK LOW TIRE PRESSURE WARNING CONTROL UNIT POWER SUPPLY CIRCUIT

1. Disconnect the low tire pressure warning control unit harness connector.
2. Turn the ignition switch ON.  
**CAUTION:**  
**Never start engine.**
3. Check the voltage between the low tire pressure warning control unit and ground.

Low tire pressure warning control unit		—	Voltage
Connector	Terminal		
M96	15	Ground	Battery voltage

4. Turn the ignition switch OFF.
5. Check the voltage between the low tire pressure warning control unit and ground.

Low tire pressure warning control unit		—	Voltage
Connector	Terminal		
M96	15	Ground	0 V

Is the inspection result normal?

- YES >> GO TO 3.  
NO >> Check the following. If any items are damaged, repair or replace damaged parts.
- Harness for short or open between ignition switch and low tire pressure warning control unit harness connector
  - Battery voltage.

#### 3. CHECK LOW TIRE PRESSURE WARNING CONTROL UNIT GROUND CIRCUIT

1. Turn the ignition switch OFF.
2. Check the continuity between the low tire pressure warning control unit harness connector and ground.

Low tire pressure warning control unit		—	Continuity
Connector	Terminal		
M96	32	Ground	Existed

- Also check harness for short to ground and short to power.

Is the inspection result normal?

- YES >> INSPECTION END  
NO >> Repair open circuit or short to ground or short to power in harness or connectors.

# LOW TIRE PRESSURE WARNING LAMP

< DTC/CIRCUIT DIAGNOSIS >

## LOW TIRE PRESSURE WARNING LAMP

### Component Function Check

INFOID:000000009008472

#### 1. CHECK LOW TIRE PRESSURE WARNING LAMP OPERATION

Check that the low tire pressure warning lamp is turned OFF after turns ON for approximately 1 second, when the ignition switch is turned ON.

Is the inspection result normal?

- YES >> INSPECTION END
- NO >> Proceed to [WT-51, "Diagnosis Procedure"](#).

### Diagnosis Procedure

INFOID:000000009008473

#### 1. CHECK LOW TIRE PRESSURE WARNING CONTROL UNIT POWER SUPPLY AND GROUND CIRCUIT

Perform the trouble diagnosis for power supply and ground circuit. Refer to [WT-50, "Diagnosis Procedure"](#).

Is the inspection result normal?

- YES >> GO TO 2.
- NO >> Repair or replace error-detected parts.

#### 2. PERFORM LOW TIRE PRESSURE WARNING CONTROL UNIT SELF-DIAGNOSIS

 **With CONSULT**

1. Drive for several minutes at a speed of 40 km/h (25 MPH) or more.
2. Stop the vehicle.
3. Perform self-diagnosis for "AIR PRESSURE MONITOR".

Is any DTC detected?

- YES >> Perform trouble diagnosis for detected DTC. Refer to [WT-18, "DTC Index"](#).
- NO >> GO TO 3.

#### 3. CHECK LOW TIRE PRESSURE WARNING LAMP SIGNAL

 **With CONSULT**

1. Turn the ignition switch ON.  
**CAUTION:**  
**Never start engine.**
2. Select "DATA MONITOR" for "AIR PRESSURE MONITOR" with CONSULT.
3. Read out the value of "WARNING LAMP". For low tire pressure warning lamp condition, refer to "LOW TIRE PRESSURE WARNING LAMP CONTROL CONDITION" in [WT-9, "System Description"](#).

Does the data monitor display change normal?

- YES >> GO TO 4.
- NO >> Replace the low tire pressure warning control unit. Refer to [WT-64, "Removal and Installation"](#).

#### 4. CHECK COMBINATION METER POWER SUPPLY CIRCUIT

Perform the trouble diagnosis for combination meter power supply circuit. Refer to [MWI-66, "COMBINATION METER : Diagnosis Procedure"](#).

Is the inspection result normal?

- YES >> INSPECTION END
- NO >> Repair or replace error-detected parts.

A  
B  
C  
D  
WT  
F  
G  
H  
I  
J  
K  
L  
M  
N  
O  
P

# TPMS SYMPTOMS

< SYMPTOM DIAGNOSIS >

---

## SYMPTOM DIAGNOSIS

### TPMS SYMPTOMS















Symptom Table

*INFOID:000000009008474*

LOW TIRE PRESSURE WARNING LAMP SYMPTOM CHART

# TPMS SYMPTOMS

## < SYMPTOM DIAGNOSIS >

Diagnosis items	Symptom (Ignition switch ON)	Low tire pressure warning lamp	Cause	Action
Low tire pressure warning lamp	The low tire pressure warning lamp illuminates for 1 second, then turns OFF.	  ON 1 sec > stays OFF <small>SEIA0592E</small>	Wake-up operation for all tire pressure sensors at wheels is completed.	No procedure. (No system malfunctions)
	The low tire pressure warning lamp repeats blinking ON for 2 seconds and OFF for 0.2 seconds.	 Blinks:  ON 2 sec > OFF 0.2 sec <small>SEIA0593E</small>	Wake-up operation for all tire pressure sensors at wheels is not completed.	Perform the wake-up operation for all tire pressure sensors at wheels. Refer to <a href="#">WT-28, "Work Procedure"</a> .
	The low tire pressure warning lamp blinks once.	 Blinks 1 time ON 0.3 sec > OFF 1.0 sec <small>JPEIC0090GB</small>	The front LH wheel tire pressure sensor is not activated.	Perform the wake-up operation for the tire pressure sensor at front LH wheel. Refer to <a href="#">WT-28, "Work Procedure"</a> .
	The low tire pressure warning lamp repeats blinking twice.	  Blinks 2 times ON 0.3 sec > OFF 0.3 sec <small>SEIA0595E</small>	The front right wheel tire pressure sensor is not activated.	Perform the wake-up operation for the tire pressure sensor at front right wheel. Refer to <a href="#">WT-28, "Work Procedure"</a> .
	The low tire pressure warning lamp repeats blinking for 3 times.	   Blinks 3 times ON 0.3 sec > OFF 0.3 sec <small>SEIA0596E</small>	The rear right wheel tire pressure sensor is not activated.	Perform the wake-up operation for the tire pressure sensor at rear right wheel. Refer to <a href="#">WT-28, "Work Procedure"</a> .
	The low tire pressure warning lamp repeats blinking for 4 times.	    Blinks 4 times ON 0.3 sec > OFF 0.3 sec <small>SEIA0597E</small>	The rear LH wheel tire pressure sensor is not activated.	Perform the wake-up operation for the tire pressure sensor at rear LH wheel. Refer to <a href="#">WT-28, "Work Procedure"</a> .
	The low tire pressure warning lamp turns ON and stays illuminated.	 Comes ON and stays ON <small>SEIA0598E</small>	Low tire pressure	Check the tire pressure for all wheels and adjust to the specified value. Refer to <a href="#">WT-68, "Tire Air Pressure"</a> .

A

B

C

D

WT

F

G

H

I

J

K

L

M

N

O

P

# TPMS SYMPTOMS

## < SYMPTOM DIAGNOSIS >

Diagnosis items	Symptom (Ignition switch ON)	Low tire pressure warning lamp	Cause	Action
Low tire pressure warning lamp	The low tire pressure warning lamp repeats blinking at 0.5-second intervals for 1 minute, and then stays illuminated.	 <p style="text-align: center;">Blinks 1 min</p> <p style="text-align: center;">ON 0.5 sec &gt; OFF 0.5 sec and stays ON</p> <p style="text-align: center;"><small>SEIA0788E</small></p>	The combination meter fuse is open or removed (or pulled out).	Check and install the combination meter fuse. If necessary, replace the fuse.
			The low tire pressure warning control unit harness connector is removed.	Check the connection conditions of the low tire pressure warning control unit harness connector, and repair if necessary.
			Tire Pressure Monitoring System (TPMS) malfunction.	<ul style="list-style-type: none"> <li>Perform self-diagnosis.</li> <li>If necessary, perform tire pressure sensor ID registration. Refer to <a href="#">WT-29, "Work Procedure"</a>.</li> </ul>
Hazard warning lamp	The hazard warning lamp does not blink twice when the tire pressure sensor is activated.	—	<ul style="list-style-type: none"> <li>The activation tool does not activate.</li> </ul>	<ul style="list-style-type: none"> <li>Replace the battery in the activation tool.</li> </ul>
			<ul style="list-style-type: none"> <li>The ignition switch is OFF when the tire pressure sensor wake-up operation is performed.</li> </ul>	<ul style="list-style-type: none"> <li>Turn the ignition switch ON when performing the tire pressure sensor wake-up operation.</li> </ul>
			<ul style="list-style-type: none"> <li>The activation tool is not used in the correct position.</li> </ul>	<ul style="list-style-type: none"> <li>Operate the activation tool in the correct position when performing the wake-up operation.</li> </ul>
			<ul style="list-style-type: none"> <li>The tire pressure sensor is already waked up.</li> </ul>	<ul style="list-style-type: none"> <li>No procedure.</li> </ul>

**NOTE:**

If tire pressure sensor wake-up operation is not completed for two or more tire pressure sensors, the applicable low tire pressure warning lamp blinking patterns are displayed continuously.  
 (Example: Blinks once/OFF/blinks 3 times = Wake-up operation is not completed at the front LH wheel and rear RH wheel tire pressure sensors.)

# LOW TIRE PRESSURE WARNING LAMP DOES NOT TURN ON

< SYMPTOM DIAGNOSIS >

## LOW TIRE PRESSURE WARNING LAMP DOES NOT TURN ON

### Description

INFOID:000000009008475

The low tire pressure warning lamp does not illuminate when the ignition switch is turned ON.

#### NOTE:

The low tire pressure warning lamp illuminates for approximately 1 second and then turns OFF when the ignition switch is turned ON. This is to check that no abnormal condition is present in the tire pressure monitoring system.

The lamp bulb may be burnt out or the tire pressure monitoring system may be malfunctioning if the low tire pressure warning lamp does not illuminate when the ignition switch is turned ON.

### Diagnosis Procedure

INFOID:000000009008476

#### 1. CHECK LOW TIRE PRESSURE WARNING LAMP

Perform trouble diagnosis for the low tire pressure warning lamp. Refer to [WT-51, "Diagnosis Procedure"](#).

Is the inspection result normal?

- YES >> Check each harness connector pin terminal for malfunction or disconnection.
- NO >> Repair or replace error-detected parts.

A  
B  
C  
D  
E  
F  
G  
H  
I  
J  
K  
L  
M  
N  
O  
P

WT

# LOW TIRE PRESSURE WARNING LAMP DOES NOT TURN OFF

< SYMPTOM DIAGNOSIS >

---

## LOW TIRE PRESSURE WARNING LAMP DOES NOT TURN OFF

### Description

INFOID:000000009008477

The low tire pressure warning lamp does not turn OFF after several seconds is passed after engine starts.

### Diagnosis Procedure

INFOID:000000009008478

---

#### 1. CHECK TIRE PRESSURE

1. Turn the ignition switch ON.

**CAUTION:**

**Never start the engine.**

2. Check the tire pressure for all wheels and adjust to the specified value. Refer to [WT-68, "Tire Air Pressure"](#).

Is the inspection result normal?

YES >> GO TO 2.

NO >> Inspect or repair the tires or wheels.

---

#### 2. CHECK LOW TIRE PRESSURE WARNING LAMP

Check low tire pressure warning lamp display.

Does not low tire pressure warning lamp turn OFF?

YES >> GO TO 3.

NO >> INSPECTION END

---

#### 3. CHECK DTC WITH LOW TIRE PRESSURE WARNING CONTROL UNIT

**Ⓢ With CONSULT**

Perform self-diagnosis for "AIR PRESSURE MONITOR".

Is any DTC detected?

YES >> Perform the diagnosis applicable to the displayed DTC. Refer to [WT-18, "DTC Index"](#).

NO >> GO TO 4.

---

#### 4. CHECK LOW TIRE PRESSURE WARNING CONTROL UNIT POWER SUPPLY AND GROUND CIRCUIT

Perform the trouble diagnosis for power supply and ground circuit. Refer to [WT-50, "Diagnosis Procedure"](#).

Is the inspection result normal?

YES >> Replace low tire pressure warning control unit. Refer to [WT-64, "Removal and Installation"](#).

NO >> Repair or replace error-detected parts.



# LOW TIRE PRESSURE WARNING LAMP BLINKS

< SYMPTOM DIAGNOSIS >

## LOW TIRE PRESSURE WARNING LAMP BLINKS

### Description

INFOID:000000009008479

The low tire pressure warning lamp blinks when the ignition switch is turned ON.

#### NOTE:

The position of an inactive tire pressure sensor can be identified by checking the blinking timing of the low tire pressure warning lamp.

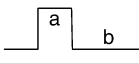
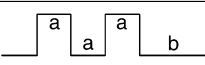
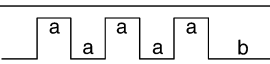
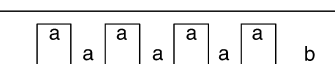
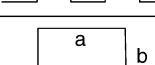
Low tire pressure warning lamp blinking timing		Activation tire position
ON OFF		a : 0.3 sec. b : 1.0 sec. Front LH
ON OFF		a : 0.3 sec. b : 1.0 sec. Front RH
ON OFF		a : 0.3 sec. b : 1.0 sec. Rear RH
ON OFF		a : 0.3 sec. b : 1.0 sec. Rear LH
ON OFF		a : 2 sec. b : 0.2 sec. All tires

JPEIC0089GB

### Diagnosis Procedure

INFOID:000000009008480

#### 1. TIRE PRESSURE SENSOR WAKE-UP OPERATION

Perform the tire pressure sensor wake-up. Refer to [WT-28, "Work Procedure"](#).

Is the tire pressure sensor wake-up completed?

YES >> GO TO 2.

NO >> Perform trouble diagnosis for the tire pressure sensor. Refer to [WT-32, "Diagnosis Procedure"](#).

#### 2. TIRE PRESSURE SENSOR ID REGISTRATION

Perform tire pressure sensor ID registration. Refer to [WT-29, "Work Procedure"](#).

Is tire pressure sensor ID registration completed?

YES >> INSPECTION END

NO >> Perform the self-diagnosis for "AIR PRESSURE MONITOR". Refer to [WT-18, "DTC Index"](#).

# TIRE INFLATION INDICATOR DOES NOT ACTIVATE

< SYMPTOM DIAGNOSIS >

---

## TIRE INFLATION INDICATOR DOES NOT ACTIVATE

### Description

INFOID:000000009008481

The tire inflation indicator does not function while inflating a tire when the A/T shift selector position is in P-range with the ignition switch ON or with the engine started.

#### NOTE:

- After starting to inflate the tire, it takes a few seconds for the tire inflation indicator to function.
- If there is no response for approximately 15 seconds or more after inflating the tires, cancel the use of the tire inflation indicator function or move the vehicle approximately 1 m (3.2 ft) backward or forward to try again. The air filler pressure may be weak or out of service area.
- For tire inflation indicator, Refer to [WT-10, "Tire Inflation Indicator Function"](#).

### Diagnosis Procedure

INFOID:000000009008482

#### 1. LOCATION CHANGE

Move the vehicle to other area and repeat the procedure of the tire inflation indicator function. Refer to [WT-10, "Tire Inflation Indicator Function"](#).

##### Is the function normal?

- YES >> Normal (the tire inflation indicator may not operate, depending on reception condition.)  
NO >> GO TO 2.

#### 2. PERFORM LOW TIRE PRESSURE WARNING CONTROL UNIT SELF-DIAGNOSIS

##### With CONSULT

1. Drive for 10 minutes at a speed of 40 km/h (25 MPH) or more.
2. Stop the vehicle.
3. Perform self-diagnosis for "AIR PRESSURE MONITOR".

##### Is any DTC detected?

- YES >> Perform trouble diagnosis for detected DTC. Refer to [WT-18, "DTC Index"](#).  
NO >> GO TO 3.

#### 3. CHECK HAZARD WARNING LAMP OPERATION

Check hazard warning lamp operation with hazard switch.

##### Does the hazard warning lamp blink?

- YES >> GO TO 4.  
NO >> Perform trouble diagnosis for the hazard warning lamp. Refer to [EXL-112, "Symptom Table"](#).

#### 4. PERFORM TCM SELF-DIAGNOSIS

##### With CONSULT

Perform self-diagnosis for "TRANSMISSION".

##### Is any DTC detected?

- YES >> Check malfunctioning circuit. Refer to [TM-82, "DTC Index"](#).  
NO >> GO TO 5.

#### 5. CHECK HORN OPERATION

Check horn operation. Refer to [SEC-121, "Component Function Check"](#).

##### Is the operation normal?

- YES >> GO TO 6.  
NO >> Repair or replace error-detected parts.

#### 6. PERFORM BCM SELF-DIAGNOSIS

##### With CONSULT

Perform self-diagnosis for "BCM".

##### Is any DTC detected?

- YES >> Check malfunctioning circuit. Refer to [BCS-57, "DTC Index"](#).  
NO >> Replace low tire pressure warning control unit. Refer to [WT-64, "Removal and Installation"](#).

# ID REGISTRATION CANNOT BE COMPLETED

< SYMPTOM DIAGNOSIS >

## ID REGISTRATION CANNOT BE COMPLETED

### Description

INFOID:000000009008483

The ID of the tire pressure sensor installed in each wheel cannot be registered in the tire pressure monitoring system.

Inspect the tire pressure sensor or the tire pressure monitoring system circuit.

### Diagnosis Procedure

INFOID:000000009008484

#### 1. TIRE PRESSURE SENSOR WAKE-UP

Perform the tire pressure sensor wake-up. Refer to [WT-28, "Work Procedure"](#).

Is the tire pressure sensor wake-up completed?

YES >> GO TO 3.

NO >> GO TO 2.

#### 2. CHECK ACTIVATION TOOL

Check activation tool.

Is the inspection result normal?

YES >> GO TO 3.

NO >> Replace battery for tire pressure sensor activation tool, or repair or replace activation tool.

#### 3. TIRE PRESSURE SENSOR ID REGISTRATION

Perform tire pressure sensor ID registration. Refer to [WT-29, "Work Procedure"](#).

##### **CAUTION:**

**To perform ID registration, observe the following points:**

- Never register ID in a place where radio waves are interfered (e.g. radio tower).
- Never register ID in a place close to vehicles including TPMS.

Is tire pressure sensor ID registration completed?

YES >> GO TO 4.

NO >> Change the work location and perform ID registration again.

#### 4. CHECK TIRE PRESSURE SIGNAL

Change the work location and perform ID registration again.

##### **NOTE:**

Depending on the tire pressure sensor position\*, a blind spot exists, and the tire pressure receiver gets a poor reception. If an ID registration is performed under this condition, the registration may not be completed.

In such case, follow the instructions below to improve the radio wave receiving environment.

- Rotate tire by 90°, 180°, or 270°. (This Step is to change tire pressure sensor position.)
- Open the door close to the tire of which ID registration is ongoing.

\*: Radio wave reception condition depends on vehicle architecture (e.g. body harness layout, tire wheel design) or environment.

When ID registration is performed, which wheels do not react?

All wheels react and ID registration is possible.>>INSPECTION END

Only certain wheel(s) do not react.>>Replace applicable tire pressure sensor. Refer to [WT-63, "Removal and Installation"](#).

All wheels do not react.>>Check the tire pressure receiver. Refer to [WT-41, "Diagnosis Procedure"](#).

# NOISE, VIBRATION AND HARSHNESS (NVH) TROUBLESHOOTING

< SYMPTOM DIAGNOSIS >

## NOISE, VIBRATION AND HARSHNESS (NVH) TROUBLESHOOTING

### NVH Troubleshooting Chart

INFOID:000000009008485

Use the chart below to find the cause of the symptom. If necessary, repair or replace these parts.

Symptom		Possible cause and SUSPECTED PARTS		Reference															
				<a href="#">WT-63, "Exploded View"</a>	<a href="#">WT-63, "Inspection"</a>	<a href="#">WT-61, "Adjustment"</a>	<a href="#">WT-68, "Tire Air Pressure"</a>	<a href="#">WT-63, "Inspection"</a>	—	—	<a href="#">WT-68, "Tire Air Pressure"</a>	NVH in DLN section.	NVH in DLN section.	NVH in FAX and FSU sections.	NVH in RAX and RSU sections.	Refer to TIRES in this chart.	Refer to ROAD WHEEL in this chart.	NVH in FAX, RAX section.	NVH in BR section.
Symptom	TIRES	Noise	x	x	x	x	x	x	x		x	x	x	x		x	x	x	x
		Shake	x	x	x	x	x	x	x		x		x	x		x	x	x	x
		Vibration				x				x	x		x	x			x		
		Shimmy	x	x	x	x	x	x	x	x			x	x		x		x	x
		Judder	x	x	x	x	x	x		x			x	x		x		x	x
		Poor quality ride or handling	x	x	x	x	x	x		x			x		x				
	ROAD WHEEL	Noise	x	x	x				x		x	x	x	x	x		x	x	x
		Shake	x	x	x				x			x	x	x			x	x	x
		Shimmy, Judder	x	x	x				x				x	x	x			x	x
		Poor quality ride or handling	x	x	x				x				x	x	x				

x: Applicable

# ROAD WHEEL

< PERIODIC MAINTENANCE >

## PERIODIC MAINTENANCE

### ROAD WHEEL

#### Adjustment

INFOID:000000009008486

#### BALANCING WHEELS (BONDING WEIGHT TYPE)

##### Preparation Before Adjustment

Using releasing agent, remove double-faced adhesive tape from the road wheel.

##### **CAUTION:**

- **Never scratch the road wheel during removal.**
- **After removing double-faced adhesive tape, wipe clean traces of releasing agent from the road wheel.**

##### Wheel Balance Adjustment

If a tire balance machine has adhesion balance weight mode settings and drive-in weight mode setting, select and adjust a drive-in weight mode suitable for road wheels.

1. Set road wheel on tire balance machine using the center hole as a guide. Start the tire balance machine.
2. When inner and outer unbalance values are shown on the tire balance machine indicator, multiply outer unbalance value by  $5/3$  to determine balance weight that should be used. Select the outer balance weight with a value closest to the calculated value above and install to the designated outer position of, or at the designated angle in relation to the road wheel.

##### **CAUTION:**

- **Never install the inner balance weight before installing the outer balance weight.**
- **Before installing the balance weight, always to clean the mating surface of the road wheel.**

- a. Indicated unbalance value  $\times 5/3 =$  balance weight to be installed

##### **Calculation example:**

$23 \text{ g (0.81 oz)} \times 5/3 = 38.33 \text{ g (1.35 oz)} \Rightarrow 37.5 \text{ g (1.32 oz)}$  balance weight (closer to calculated balance weight value)

##### **NOTE:**

Note that balance weight value must be closer to the calculated balance weight value.

##### **Example:**

$36.2 \Rightarrow 35 \text{ g (1.23 oz)}$

$36.3 \Rightarrow 37.5 \text{ g (1.32 oz)}$

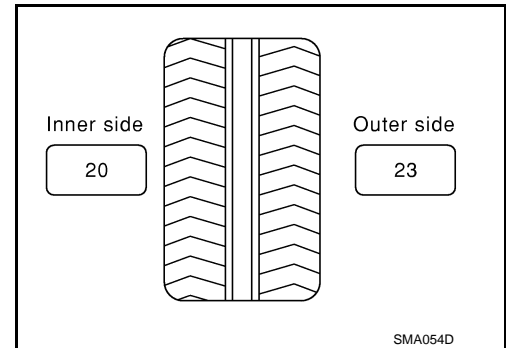

- b. Installed balance weight in the position.

# ROAD WHEEL

## < PERIODIC MAINTENANCE >

- When installing balance weight (1) to road wheels, set it into the grooved area (A) on the inner wall of the road wheel as shown in the figure so that the balance weight center (B) is aligned with the tire balance machine indication position (angle) (C).

**CAUTION:**

- Always use genuine NISSAN adhesion balance weights.
- Balance weights are non-reusable; always replace with new ones.
- Never install more than four sheets of balance weight.

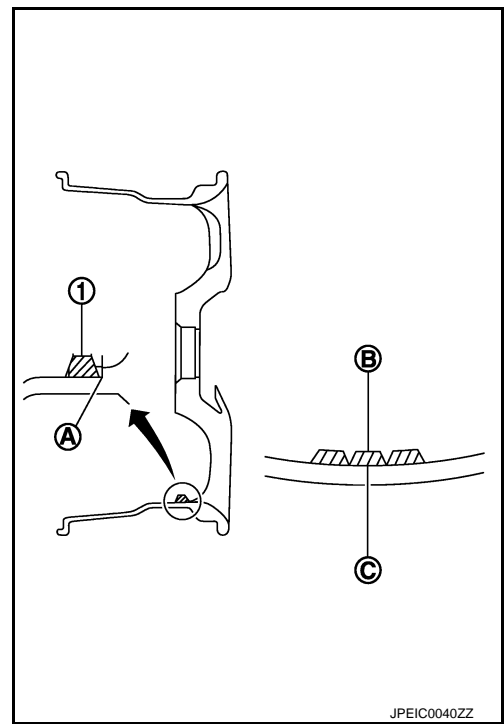

JPEIC0040ZZ

- If calculated balance weight value exceeds 50 g (1.76 oz), install two balance weight sheets in line with each other as shown in the figure.

**CAUTION:**

**Never install one balance weight sheet on top of another.**

- Start the tire balance machine again.
- Install drive-in balance weight on inner side of road wheel in the tire balance machine indication position (angle).

**CAUTION:**

**Never install more than two balance weight.**

- Start the tire balance machine. Check that the inner and outer residual unbalance value is within the allowable unbalance value.

**CAUTION:**

**If either residual unbalance value exceeds limit, repeat installation procedures.**

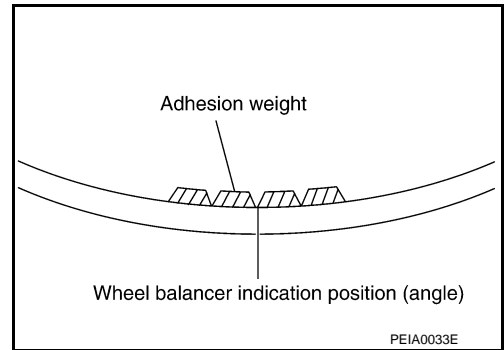

PEIA0033E

**Allowable unbalance value**

**Dynamic (At flange) : Refer to [WT-68, "Road Wheel"](#).**

**Static (At flange) : Refer to [WT-68, "Road Wheel"](#).**

## Tire Rotation

INFOID:000000009008487

- Follow the maintenance schedule for tire rotation service intervals. Refer to [MA-4, "FOR NORTH AMERICA : Explanation of General Maintenance"](#) (For North America) or [MA-6, "FOR MEXICO : General Maintenance"](#) (For Mexico).
- When installing the wheel, tighten wheel nuts to the specified torque. Refer to [WT-63, "Exploded View"](#).

**CAUTION:**

- When installing wheels, tighten them diagonally by dividing the work two to three times in order to prevent the wheels from developing any distortion.
- Never tighten wheel nut at torque exceeding the criteria.
- Use NISSAN genuine wheel nuts for aluminum wheels.
- Perform the ID registration, after tire rotation. Refer to [WT-29, "Work Procedure"](#).

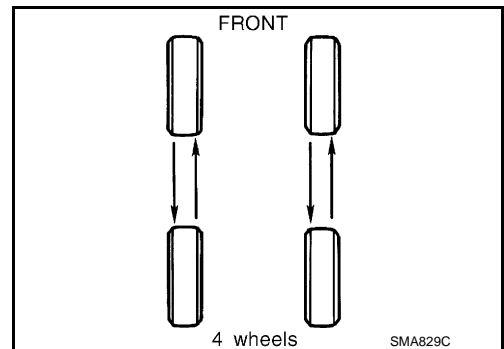

4 wheels

SMA829C

# ROAD WHEEL TIRE ASSEMBLY

< REMOVAL AND INSTALLATION >

## REMOVAL AND INSTALLATION

### ROAD WHEEL TIRE ASSEMBLY

Exploded View

INFOID:000000009008488

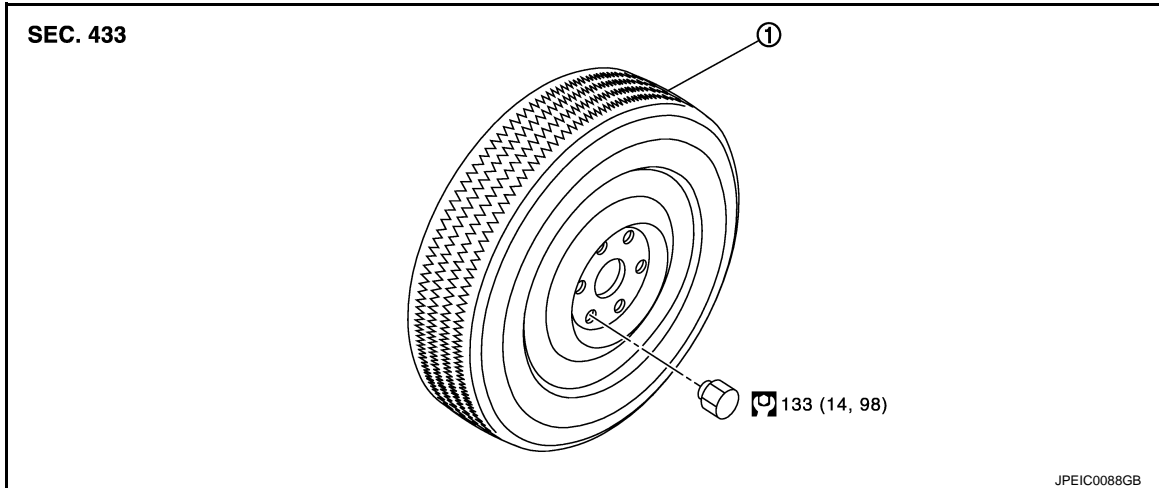

1. Tire assembly

Refer to [GI-4, "Components"](#) for symbols in the figure.

### Removal and Installation

INFOID:000000009008489

#### REMOVAL

1. Remove wheel nuts.
2. Remove tire assembly.

#### INSTALLATION

Note the following, install in the reverse order of removal.

- When replacing or rotating wheels, perform the ID registration. Refer to [WT-29, "Work Procedure"](#).

### Inspection

INFOID:000000009008490

#### ALUMINUM WHEEL

1. Check tires for wear and improper inflation.
2. Check wheels for deformation, cracks and other damage. If deformed, remove wheel and check wheel runout.
  - a. Remove tire from aluminum wheel and mount on a tire balance machine.
  - b. Set dial indicator as shown in the figure.
  - c. Check runout, if the axial runout (A) or radial runout (B) exceeds the limit, replace aluminum wheel.

#### Limit

**Axial runout (A)** : Refer to [WT-68, "Road Wheel"](#).

**Radial runout (B)** : Refer to [WT-68, "Road Wheel"](#).

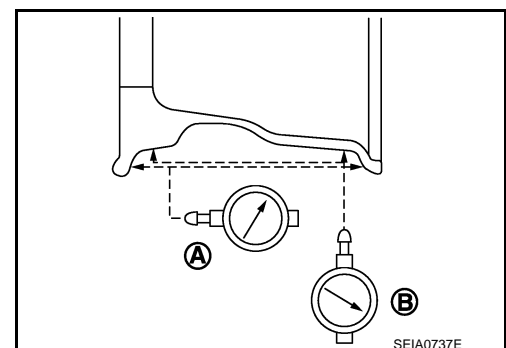

# LOW TIRE PRESSURE WARNING CONTROL UNIT

< REMOVAL AND INSTALLATION >

## LOW TIRE PRESSURE WARNING CONTROL UNIT

Exploded View

INFOID:000000009008491

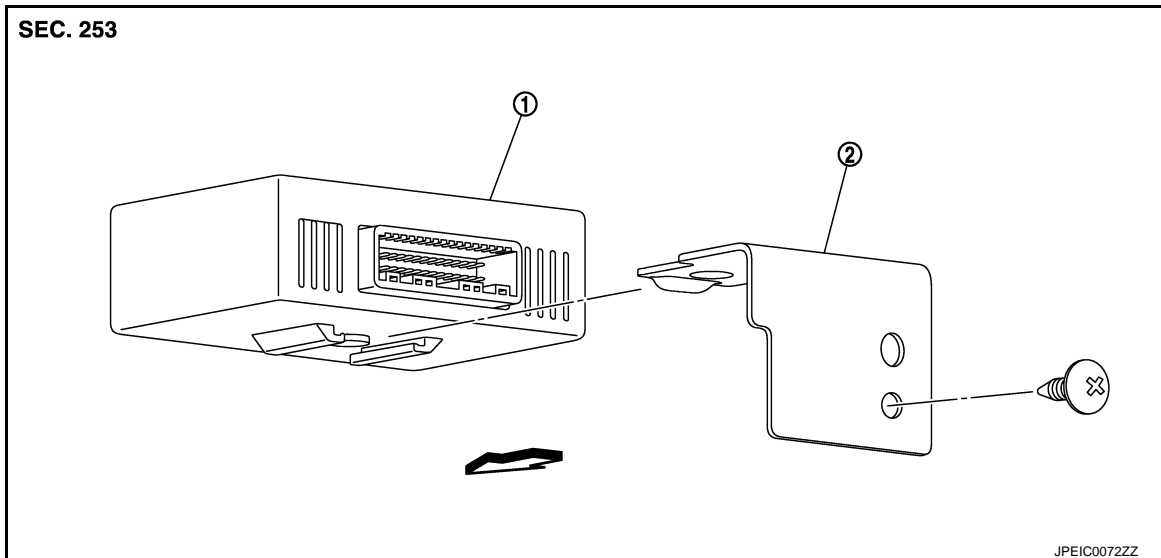

1. Low tire pressure warning control unit 2. Bracket

↩: Vehicle front

Refer to [GI-4, "Components"](#) for symbols in the figure.

## Removal and Installation

INFOID:000000009008492

### REMOVAL

1. Remove the glove box assembly. Refer to [IP-14, "Removal and Installation"](#).
2. Remove the instrument lower panel RH. Refer to [IP-14, "Removal and Installation"](#).
3. Disconnect low tire pressure warning control unit connector.
4. Remove the low tire pressure warning control unit control unit.

### INSTALLATION

Note the following, install in the reverse order of removal.

- Perform ID registration after replacing low tire pressure warning control unit. Refer to [WT-29, "Work Procedure"](#).



# TIRE PRESSURE SENSOR

< REMOVAL AND INSTALLATION >

## TIRE PRESSURE SENSOR

### Exploded View

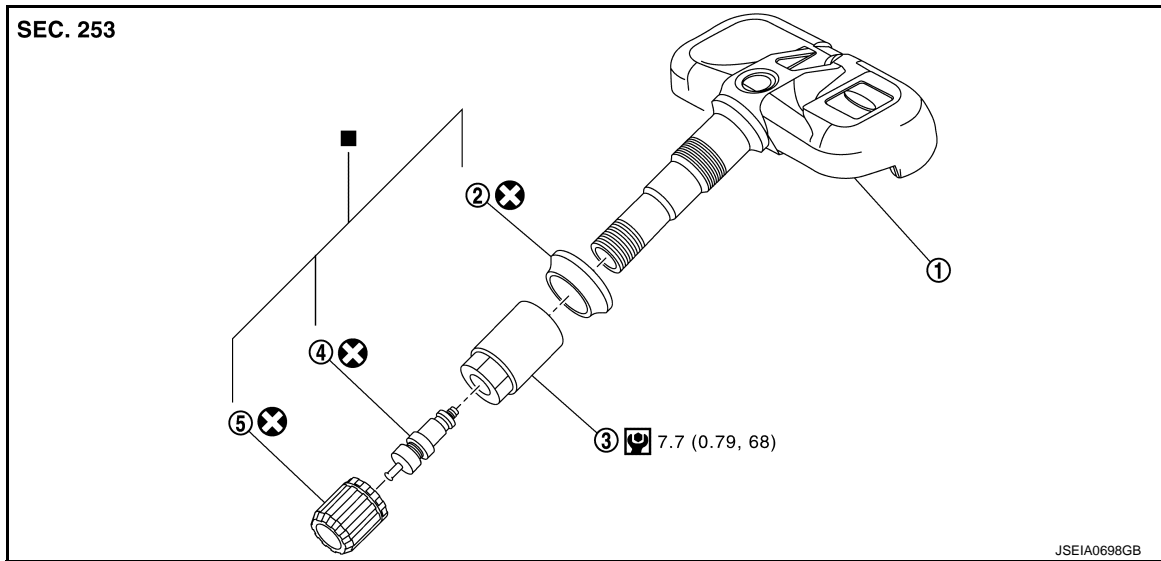

- |                         |                 |              |
|-------------------------|-----------------|--------------|
| 1. Tire pressure sensor | 2. Grommet seal | 3. Valve nut |
| 4. Valve core           | 5. Valve cap    |              |

■ : Parts that are replaced as a set when the tire is replaced.

Refer to [GI-4, "Components"](#) for symbols not described above.

### Removal and Installation

INFOID:000000009008494

#### REMOVAL

1. Remove tire assembly. Refer to [WT-63, "Removal and Installation"](#).
2. Remove valve cap, valve core and then deflate tire.

#### NOTE:

If the tire is reused, apply a matching mark to the position of the tire road wheel valve hole for the purpose of wheel balance adjustment after installation.

3. Remove valve nut retaining tire pressure sensor and allow tire pressure sensor to fall into tire.
4. Use the tire changer and disengage the tire beads.

#### CAUTION:

- Verify that the tire pressure sensor (1) is at the bottom of the tire while performing the above.
  - Never damage the road wheel or tire pressure sensor.
5. Apply bead cream or an equivalent to the tire beads.
  6. Set tire onto the tire changer turntable so that the tire pressure sensor inside the tire is located close to the road wheel valve hole.

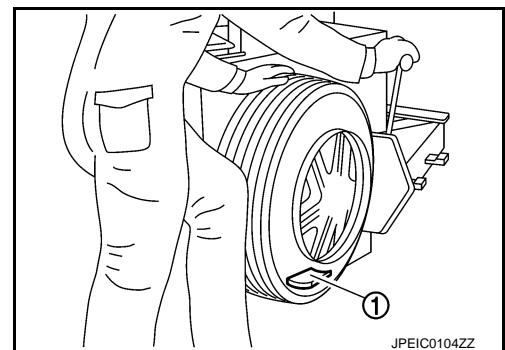

# TIRE PRESSURE SENSOR

## < REMOVAL AND INSTALLATION >

- Turn tire so that valve hole is at bottom and bounce so that tire pressure sensor (1) is near valve hole. Carefully lift tire onto turntable and position valve hole (and tire pressure sensor) 270 degree from mounting/dismounting head (2).

**CAUTION:**

**Never damage the road wheel and tire pressure sensor.**

- Remove tire pressure sensor from tire.
- Remove the grommet seal.

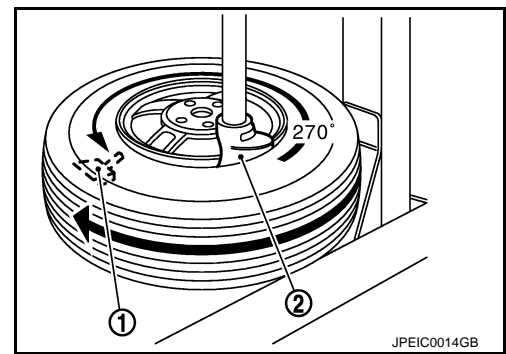

## INSTALLATION

- Apply bead cream or an equivalent to the tire beads.
- Install the tire inside beads (1) onto the road wheel (2) in the position shown in the figure.
- Install grommet seal to the tire pressure sensor.

**CAUTION:**

- **Never reuse grommet seal.**
- **Insert grommet seal all the way to the base.**

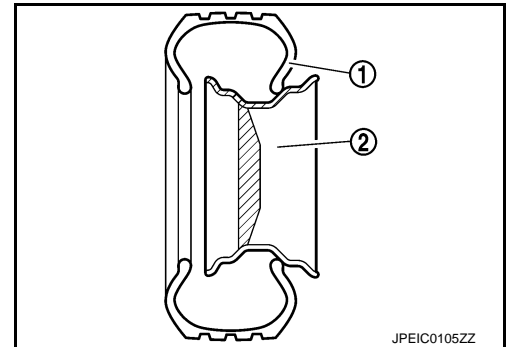

- Hold tire pressure sensor as shown in the figure, and press the sensor in the direction shown by arrow (←) to bring it into absolute contact with valve hole. After this, tighten valve nut to the specified torque.

**CAUTION:**

- **Never reuse valve core and valve cap.**
- **Check that grommet seal is free of foreign matter.**
- **Check that grommet seal contacts horizontally with road wheel.**
- **Manually tighten valve nut all the way to the wheel. (Never use a power tool to avoid impact.)**

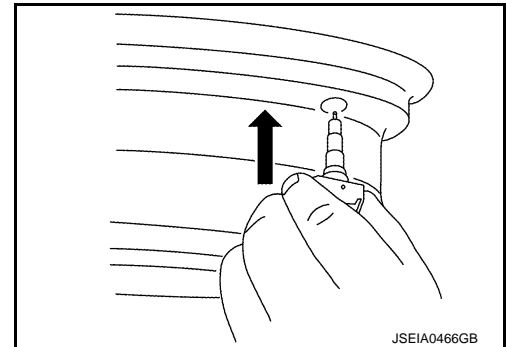

- Set the tire onto the turntable so that the tire changer arm (2) is at a position approximately 270° from the tire pressure sensor (1).

**CAUTION:**

**Be sure that the arm does not contact the tire pressure sensor.**

- Install the tire outer side beads onto the road wheel.

**CAUTION:**

**When installing, check that the tire does not turn together with the road wheel.**

- Check the tire pressure for all wheels and adjust to the specified value. Refer to [WT-68, "Tire Air Pressure"](#).

**NOTE:**

Before adding air, align the tire with the position of the matching mark applied at the time of removal.

- Install tire to the vehicle. Refer to [WT-63, "Removal and Installation"](#).
- Perform tire pressure sensor ID registration. Refer to [WT-29, "Work Procedure"](#).

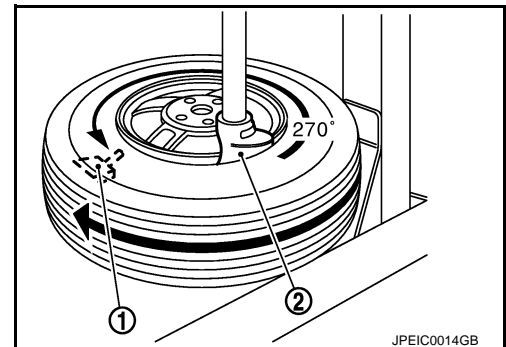

# TIRE PRESSURE RECEIVER

< REMOVAL AND INSTALLATION >

## TIRE PRESSURE RECEIVER

Exploded View

INFOID:000000009008495

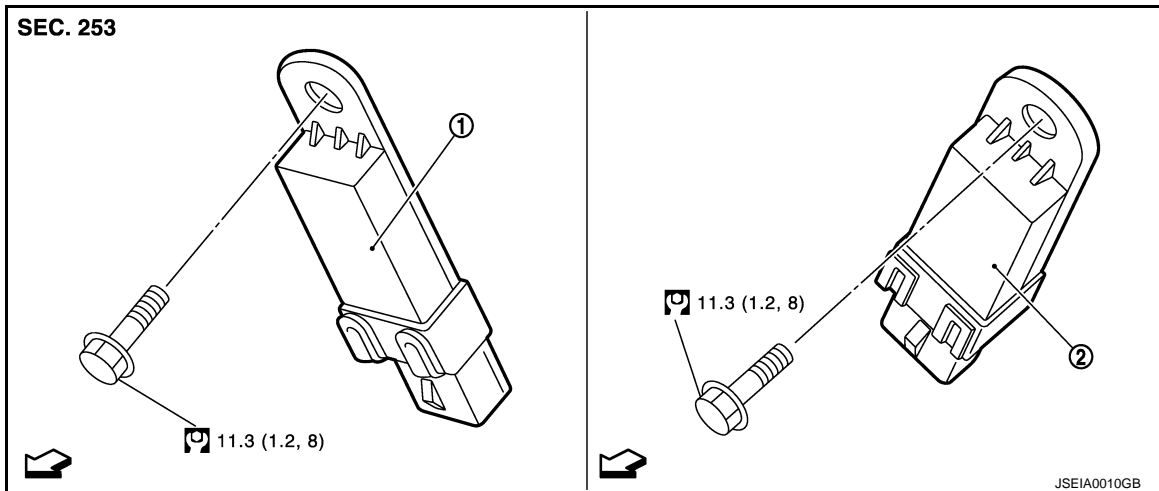

1. Front tire pressure receiver      2. Rear tire pressure receiver

↶: Vehicle front

Refer to [GI-4, "Components"](#) for symbols in the figure.

## FRONT TIRE PRESSURE RECEIVER

### FRONT TIRE PRESSURE RECEIVER : Removal and Installation

INFOID:000000009008496

#### REMOVAL

1. Remove fender protector (rear). Refer to [EXT-24, "FENDER PROTECTOR : Removal and Installation"](#).
2. Remove mounting bolt for the front tire pressure receiver.
3. Disconnect front tire pressure receiver harness connector.
4. Remove front tire pressure receiver.

#### INSTALLATION

Installation is the reverse order of removal.

## REAR TIRE PRESSURE RECEIVER

### REAR TIRE PRESSURE RECEIVER : Removal and Installation

INFOID:000000009008497

#### REMOVAL

1. Remove rear wheel house protector. Refer to [EXT-25, "REAR WHEEL HOUSE PROTECTOR : Removal and Installation"](#).
2. Remove mounting bolt for the rear tire pressure receiver.
3. Disconnect rear tire pressure receiver harness connector.
4. Remove rear tire pressure receiver.

#### INSTALLATION

Installation is the reverse order of removal.

A  
B  
C  
D  
WT  
F  
G  
H  
I  
J  
K  
L  
M  
N  
O  
P

## SERVICE DATA AND SPECIFICATIONS (SDS)

< SERVICE DATA AND SPECIFICATIONS (SDS)

## SERVICE DATA AND SPECIFICATIONS (SDS)

### SERVICE DATA AND SPECIFICATIONS (SDS)

#### Road Wheel

INFOID:000000009008498

#### ALUMINUM WHEEL

Item		Limit
Runout	Axial runout	Less than 0.3 mm (0.012 in)
	Radial runout	
Allowable unbalance	Dynamic (At flange)	Less than 5 g (0.17 oz) (one side)
	Static (At flange)	Less than 10 g (0.35 oz)

#### Tire Air Pressure

INFOID:000000009008499

Unit: kPa (kg/cm<sup>2</sup>, psi)

Tire size	Air pressure	
	Front	Rear
P275/60R20 114H	240 (2.4, 35)	
275/60R20 115M (EMERGENCY)	240 (2.4, 35)	
P275/50R22 111H	240 (2.4, 35)	