

SECTION **LT**
LIGHTING SYSTEM

A
 B
 C
 D
 E
 F
 G
 H
 I
 J
 LT
 L
 M
 N
 O
 P

CONTENTS

<p>SERVICE INFORMATION 4</p> <p>PRECAUTIONS 4</p> <p style="padding-left: 20px;">Precaution for Supplemental Restraint System (SRS) "AIR BAG" and "SEAT BELT PRE-TENSIONER"4</p> <p style="padding-left: 20px;">General precautions for service operations4</p> <p>HEADLAMP (FOR USA) 5</p> <p style="padding-left: 20px;">Component Parts and Harness Connector Location5</p> <p style="padding-left: 20px;">System Description5</p> <p style="padding-left: 20px;">CAN Communication System Description6</p> <p style="padding-left: 20px;">Schematic7</p> <p style="padding-left: 20px;">Wiring Diagram - H/LAMP -8</p> <p style="padding-left: 20px;">Terminal and Reference Value for BCM 11</p> <p style="padding-left: 20px;">Terminal and Reference Value for IPDM E/R 11</p> <p style="padding-left: 20px;">How to Proceed with Trouble Diagnosis 12</p> <p style="padding-left: 20px;">Preliminary Check 12</p> <p style="padding-left: 20px;">CONSULT-III Function (BCM) 12</p> <p style="padding-left: 20px;">CONSULT-III Function (IPDM E/R) 14</p> <p style="padding-left: 20px;">Headlamp HI Does Not Illuminate (Both Sides) 15</p> <p style="padding-left: 20px;">Headlamp HI Does Not Illuminate (One Side) 17</p> <p style="padding-left: 20px;">High-Beam Indicator Lamp Does Not Illuminate 18</p> <p style="padding-left: 20px;">Headlamp LO Does Not Illuminate (Both Sides) 18</p> <p style="padding-left: 20px;">Headlamp LO Does Not Illuminate (One Side) 20</p> <p style="padding-left: 20px;">Headlamps Do Not Turn OFF 21</p> <p style="padding-left: 20px;">Aiming Adjustment 21</p> <p style="padding-left: 20px;">Bulb Replacement 22</p> <p style="padding-left: 20px;">Removal and Installation 23</p> <p style="padding-left: 20px;">Disassembly and Assembly 24</p> <p>HEADLAMP (FOR CANADA) - DAYTIME LIGHT SYSTEM -25</p> <p style="padding-left: 20px;">Component Parts and Harness Connector Location25</p> <p style="padding-left: 20px;">System Description25</p> <p style="padding-left: 20px;">CAN Communication System Description27</p> <p style="padding-left: 20px;">Schematic28</p> <p style="padding-left: 20px;">Wiring Diagram - DTRL -29</p> <p style="padding-left: 20px;">Trouble Diagnosis32</p>	<p style="padding-left: 20px;">Aiming Adjustment33</p> <p style="padding-left: 20px;">Bulb Replacement33</p> <p style="padding-left: 20px;">Removal and Installation33</p> <p style="padding-left: 20px;">Disassembly and Assembly34</p> <p>AUTO LIGHT SYSTEM35</p> <p style="padding-left: 20px;">Component Parts and Harness Connector Location 35</p> <p style="padding-left: 20px;">System Description35</p> <p style="padding-left: 20px;">CAN Communication System Description36</p> <p style="padding-left: 20px;">Major Component and Functions36</p> <p style="padding-left: 20px;">Schematic37</p> <p style="padding-left: 20px;">Wiring Diagram - AUTO/L -38</p> <p style="padding-left: 20px;">Terminal and Reference Value for BCM40</p> <p style="padding-left: 20px;">Terminal and Reference Value for IPDM E/R40</p> <p style="padding-left: 20px;">How to Proceed with Trouble Diagnosis41</p> <p style="padding-left: 20px;">Preliminary Check41</p> <p style="padding-left: 20px;">CONSULT-III Function (BCM)41</p> <p style="padding-left: 20px;">CONSULT-III Function (IPDM E/R)43</p> <p style="padding-left: 20px;">Trouble Diagnosis Chart by Symptom44</p> <p style="padding-left: 20px;">Lighting Switch Inspection45</p> <p style="padding-left: 20px;">Optical Sensor System Inspection45</p> <p style="padding-left: 20px;">Removal and Installation46</p> <p>FRONT FOG LAMP47</p> <p style="padding-left: 20px;">Component Parts and Harness Connector Location47</p> <p style="padding-left: 20px;">System Description47</p> <p style="padding-left: 20px;">CAN Communication System Description48</p> <p style="padding-left: 20px;">Wiring Diagram - F/FOG -49</p> <p style="padding-left: 20px;">Terminal and Reference Value for BCM50</p> <p style="padding-left: 20px;">Terminal and Reference Value for IPDM E/R50</p> <p style="padding-left: 20px;">How to Proceed with Trouble Diagnosis51</p> <p style="padding-left: 20px;">Preliminary Check51</p> <p style="padding-left: 20px;">CONSULT-III Functions51</p> <p style="padding-left: 20px;">Front Fog Lamps Do Not Illuminate (Both Sides)51</p> <p style="padding-left: 20px;">Front Fog Lamp Does Not Illuminate (One Side)52</p> <p style="padding-left: 20px;">Aiming Adjustment52</p> <p style="padding-left: 20px;">Bulb Replacement53</p> <p style="padding-left: 20px;">Front Fog Lamp Assembly54</p>
---------------------------------------------------------------------------------------------------------------------------------------------------------------------------------------------------------------------------------------------------------------------------------------------------------------------------------------------------------------------------------------------------------------------------------------------------------------------------------------------------------------------------------------------------------------------------------------------------------------------------------------------------------------------------------------------------------------------------------------------------------------------------------------------------------------------------------------------------------------------------------------------------------------------------------------------------------------------------------------------------------------------------------------------------------------------------------------------------------------------------------------------------------------------------------------------------------------------------------------------------------------------------------------------------------------------------------------------------------------------------------------------------------------------------------------------------------------------------------------------------------------------------------------------------------------------------------------------------------------------------------------------------------------------------------------------------------------------------------------------------------------------------------------------------------------------------------------------------------------------------------------------------------------------------------------------------------------------------------------------------------------------------------------------------------------------------------------------------------------------------------------------------------------------------------------------------------------------------------------------------------------------------------------------------------------------------------------------------------------------------------------------------------------------------------------------------------------------------------------------	--------------------------------------------------------------------------------------------------------------------------------------------------------------------------------------------------------------------------------------------------------------------------------------------------------------------------------------------------------------------------------------------------------------------------------------------------------------------------------------------------------------------------------------------------------------------------------------------------------------------------------------------------------------------------------------------------------------------------------------------------------------------------------------------------------------------------------------------------------------------------------------------------------------------------------------------------------------------------------------------------------------------------------------------------------------------------------------------------------------------------------------------------------------------------------------------------------------------------------------------------------------------------------------------------------------------------------------------------------------------------------------------------------------------------------------------------------------------------------------------------------------------------------------------------------------------------------------------------------------------------------------------------------------------------------------------------------------------------------------------------------------------------------------------------------------------------------------------------------------------------------------------------------------------------------------------------------------------------------------------------------------------------------------------------------------------------------------------------------------------------------------------------------------------------------------------------------------------------------------------------------------------------------------------------------------------------------------------------------------------------------------------------------------------------------------------------------------------------------------------------------------------------------------------------------------------------------------------------------------------------------------------------

TURN SIGNAL AND HAZARD WARNING LAMPS	55	Bulb Replacement	88
Component Parts and Harness Connector Location	55	Removal and Installation	89
System Description	55	PARKING, LICENSE PLATE AND TAIL LAMPS	90
CAN Communication System Description	57	Component Parts and Harness Connector Location	90
Schematic	58	System Description	90
Wiring Diagram - TURN -	59	CAN Communication System Description	91
Terminal and Reference Value for BCM	62	Schematic	92
How to Proceed with Trouble Diagnosis	62	Wiring Diagram - TAIL/L -	93
BCM Power Supply and Ground Circuit Inspection	63	Terminal and Reference Value for BCM	96
CONSULT-III Function (BCM)	63	Terminal and Reference Value for IPDM E/R	96
Front Turn Signal Lamp Does Not Operate	64	How to Proceed with Trouble Diagnosis	97
Rear Turn Signal Lamp Does Not Operate	65	Preliminary Check	97
Hazard Warning Lamp Does Not Operate But Turn Signal Lamp Operates	66	CONSULT-III Functions	97
Turn Signal Indicator Lamp Does Not Operate	67	Parking, License Plate and/or Tail Lamps Do Not Illuminate	97
Bulb Replacement	67	Parking, License Plate and Tail Lamps Do Not Turn OFF (After Approx. 10 Minutes)	100
Removal and Installation	67	Bulb Replacement	100
CORNERING LAMP	68	Removal and Installation	100
Component Parts and Harness Connector Location	68	REAR COMBINATION LAMP	102
System Description	68	Bulb Replacement	102
CAN Communication System Description	69	Removal and Installation	102
Schematic	70	TRAILER TOW	103
Wiring Diagram - CORNER -	71	Component Parts and Harness Connector Location	103
Terminal and Reference Value for BCM	73	System Description	103
Terminal and Reference Value for IPDM E/R	73	Wiring Diagram - T/TOW -	104
How to Proceed with Trouble Diagnosis	74	Trouble Diagnosis	104
Preliminary Check	74	INTERIOR ROOM LAMP	106
CONSULT-III Function (IPDM E/R)	74	Component Parts and Harness Connector Location	106
Cornering Lamp Does Not Operate	75	System Description	107
Bulb Replacement	76	Schematic	111
Removal and Installation	76	Wiring Diagram - INT/L -	113
LIGHTING AND TURN SIGNAL SWITCH	77	Terminal and Reference Value for BCM	119
Removal	77	How to Proceed with Trouble Diagnosis	119
Installation	77	Preliminary Check	120
HAZARD SWITCH	78	CONSULT-III Function (BCM)	120
Removal and Installation	78	Room/Map Lamp Control Does Not Operate	122
COMBINATION SWITCH	79	Personal Lamp Control Does Not Operate (Room/Map Lamps Operate)	123
Wiring Diagram - COMBSW -	79	Ignition Keyhole Illumination Control Does Not Operate	124
Combination Switch Reading Function	79	All Step/Foot Lamps Do Not Operate	125
CONSULT-III Function (BCM)	80	All Interior Room Lamps Do Not Operate	126
Combination Switch Inspection	81	ILLUMINATION	127
Removal and Installation	83	Component Parts and Harness Connector Location	127
Switch Circuit Inspection	83	System Description	127
STOP LAMP	84	CAN Communication System Description	129
System Description	84	Schematic	130
Wiring Diagram - STOP/L -	85	Wiring Diagram - ILL -	132
Bulb Replacement	86		
Removal and Installation	87		
BACK-UP LAMP	88		
Wiring Diagram - BACK/L -	88		

BULB SPECIFICATIONS	140	Exterior Lamp	140
Headlamp	140	Interior Lamp/Illumination	140

A

B

C

D

E

F

G

H

I

J

LT

L

M

N

O

P

PRECAUTIONS

< SERVICE INFORMATION >

SERVICE INFORMATION

PRECAUTIONS

Precaution for Supplemental Restraint System (SRS) "AIR BAG" and "SEAT BELT PRE-TENSIONER"

INFOID:000000001719031

The Supplemental Restraint System such as "AIR BAG" and "SEAT BELT PRE-TENSIONER", used along with a front seat belt, helps to reduce the risk or severity of injury to the driver and front passenger for certain types of collision. This system includes seat belt switch inputs and dual stage front air bag modules. The SRS system uses the seat belt switches to determine the front air bag deployment, and may only deploy one front air bag, depending on the severity of a collision and whether the front occupants are belted or unbelted. Information necessary to service the system safely is included in the SRS and SB section of this Service Manual.

WARNING:

- **To avoid rendering the SRS inoperative, which could increase the risk of personal injury or death in the event of a collision which would result in air bag inflation, all maintenance must be performed by an authorized NISSAN/INFINITI dealer.**
- **Improper maintenance, including incorrect removal and installation of the SRS, can lead to personal injury caused by unintentional activation of the system. For removal of Spiral Cable and Air Bag Module, see the SRS section.**
- **Do not use electrical test equipment on any circuit related to the SRS unless instructed to in this Service Manual. SRS wiring harnesses can be identified by yellow and/or orange harnesses or harness connectors.**

General precautions for service operations

INFOID:000000001719032

- Never work with wet hands.
- Turn the lighting switch OFF before disconnecting and connecting the connector.
- When checking the headlamp on/off operation, check it on vehicle and with the power connected to the vehicle-side connector.
- Do not touch the headlamp bulb glass surface with bare hands or allow oil or grease to get on it. Do not touch the headlamp bulb just after the headlamp is turned off, because it is very hot.
- When the bulb has burned out, wrap it in a thick vinyl bag and discard. Do not break the bulb.
- Leaving the bulb removed from the headlamp housing for a long period of time can deteriorate the performance of the lens and reflector (dirt, clouding). Always prepare a new bulb and have it on hand when replacing the bulb.
- Do not use organic solvent (paint thinner or gasoline) to clean lamps and to remove old sealant.

HEADLAMP (FOR USA)

< SERVICE INFORMATION >

HEADLAMP (FOR USA)

Component Parts and Harness Connector Location

INFOID:000000001719033

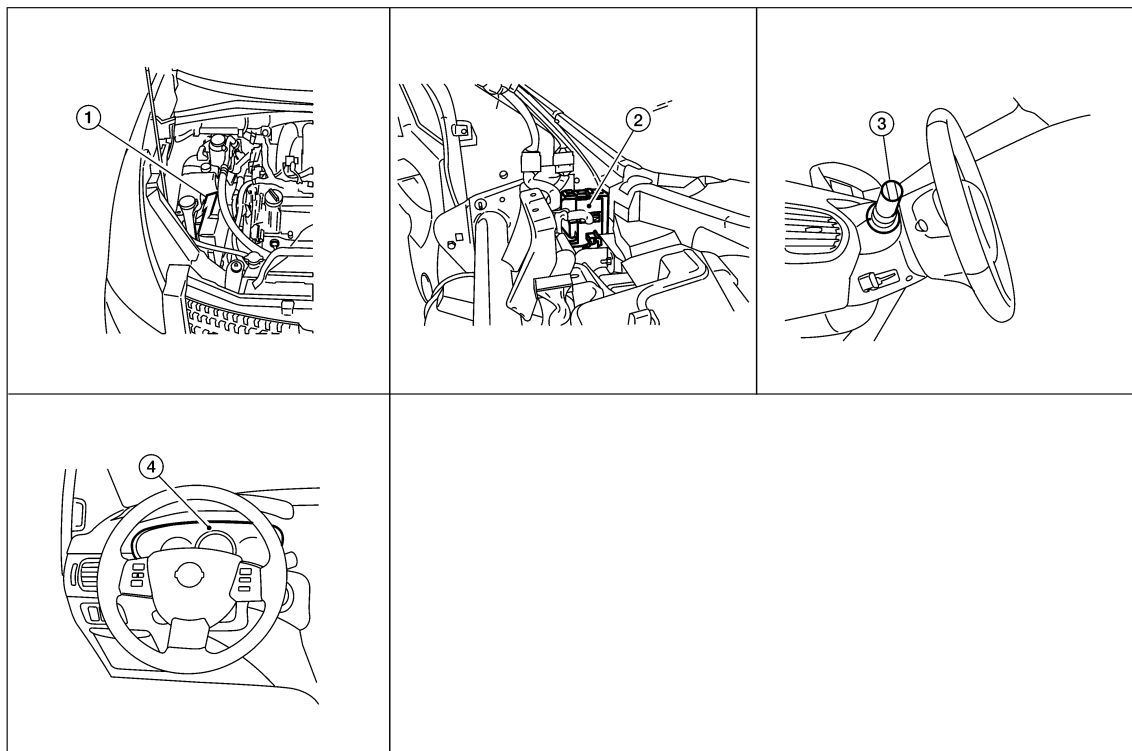

1. IPDM E/R
2. BCM M18, M20 (view with instrument panel removed)
3. Combination switch (lighting switch) M28
4. Combination meter M24

WKIA5259E

System Description

INFOID:000000001719034

Control of the headlamp system operation is dependent upon the position of the combination switch (lighting switch). When the lighting switch is placed in the 2ND position, the BCM (body control module) receives input requesting the headlamps (and tail lamps) illuminate. This input is communicated to the IPDM E/R (intelligent power distribution module engine room) across the CAN communication lines. The CPU (central processing unit) of the IPDM E/R controls the headlamp high and headlamp low relay coils. When energized, these relays direct power to the respective headlamps, which then illuminate.

OUTLINE

Power is supplied at all times

- to ignition relay, located in the IPDM E/R, and
- to headlamp high relay, located in the IPDM E/R, and
- to headlamp low relay, located in the IPDM E/R, and
- through 50A fusible link (letter j, located in the fuse and fusible link box)
- to BCM terminal 70, and
- through 15A fuse (No. 34, located in the IPDM E/R)
- to IPDM E/R CPU, and
- through 15A fuse (No. 41, located in the IPDM E/R)
- to IPDM E/R CPU, and
- through 15A fuse [No. 3, located in the fuse block (J/B)]
- to BCM terminal 57, and
- through 15A fuse [No. 19, located in the fuse block (J/B)]
- to combination meter terminal 40.

With the ignition switch in the ON or START position, power is supplied

- to ignition relay, located in the IPDM E/R, and

HEADLAMP (FOR USA)

< SERVICE INFORMATION >

- through 10A fuse [No. 16, located in the fuse block (J/B)]
- to BCM terminal 38, and
- through 10A fuse [No. 14, located in the fuse block (J/B)]
- to combination meter terminal 38.

With the ignition switch in the ACC or ON position, power is supplied

- through 10A fuse [No. 4, located in the fuse block (J/B)]
- to BCM terminal 11.

Ground is supplied

- to BCM terminal 67
- to combination meter terminal 20
- through grounds M57, M61 and M79, and
- to IPDM E/R terminals 38 and 60
- through grounds E9, E15 and E24.

Low Beam Operation

With the lighting switch in 2ND position, the BCM receives input requesting the headlamps to illuminate. This input is communicated to the IPDM E/R across the CAN communication lines. The CPU of the IPDM E/R controls the headlamp low relay coil. When energized, this relay directs power

- through 15A fuse (No. 36, located in the IPDM E/R)
- through IPDM E/R terminal 20
- to front combination lamp RH terminal 1, and
- through 15A fuse (No. 45, located in the IPDM E/R)
- through IPDM E/R terminal 30
- to front combination lamp LH terminal 1.

Ground is supplied

- to front combination lamp LH and RH terminal 2
- through grounds E9, E15 and E24.

With power and ground supplied, low beam headlamps illuminate.

High Beam Operation/Flash-to-Pass Operation

With the lighting switch in 2ND position and placed in HIGH or PASS position, the BCM receives input requesting the headlamp high beams to illuminate. This input is communicated to the IPDM E/R and combination meter across the CAN communication lines. The CPU of the combination meter controls the ON/OFF status of the HIGH BEAM indicator. The CPU of the IPDM E/R controls the headlamp high relay coil. When energized, this relay directs power

- through 10A fuse (No. 40, located in the IPDM E/R)
- through IPDM E/R terminal 27
- to front combination lamp RH terminal 3, and
- through 10A fuse (No. 38, located in the IPDM E/R)
- through IPDM E/R terminal 28
- to front combination lamp LH terminal 3.

Ground is supplied

- to front combination lamp LH and RH terminal 4
- through grounds E9, E15 and E24.

With power and ground supplied, the high beam headlamps illuminate.

BATTERY SAVER CONTROL

When the combination switch (lighting switch) is in the 2ND position (ON) and the ignition switch is turned from ON or ACC to OFF, the battery saver control feature is activated.

Under this condition, the headlamps remain illuminated for 5 minutes, unless the combination switch (lighting switch) position is changed. If the combination switch (lighting switch) position is changed, then the headlamps are turned off.

AUTO LIGHT OPERATION (IF EQUIPPED)

Refer to [LT-35, "System Description"](#) for auto light operation.

VEHICLE SECURITY SYSTEM (PANIC ALARM)

The vehicle security system (panic alarm) will flash the high beams if the system is triggered. Refer to [BL-48, "System Description"](#).

CAN Communication System Description

Refer to [LAN-3, "CAN Communication System"](#).

INFOID:000000001719035

HEADLAMP (FOR USA)

< SERVICE INFORMATION >

Schematic

INFOID:000000001719036

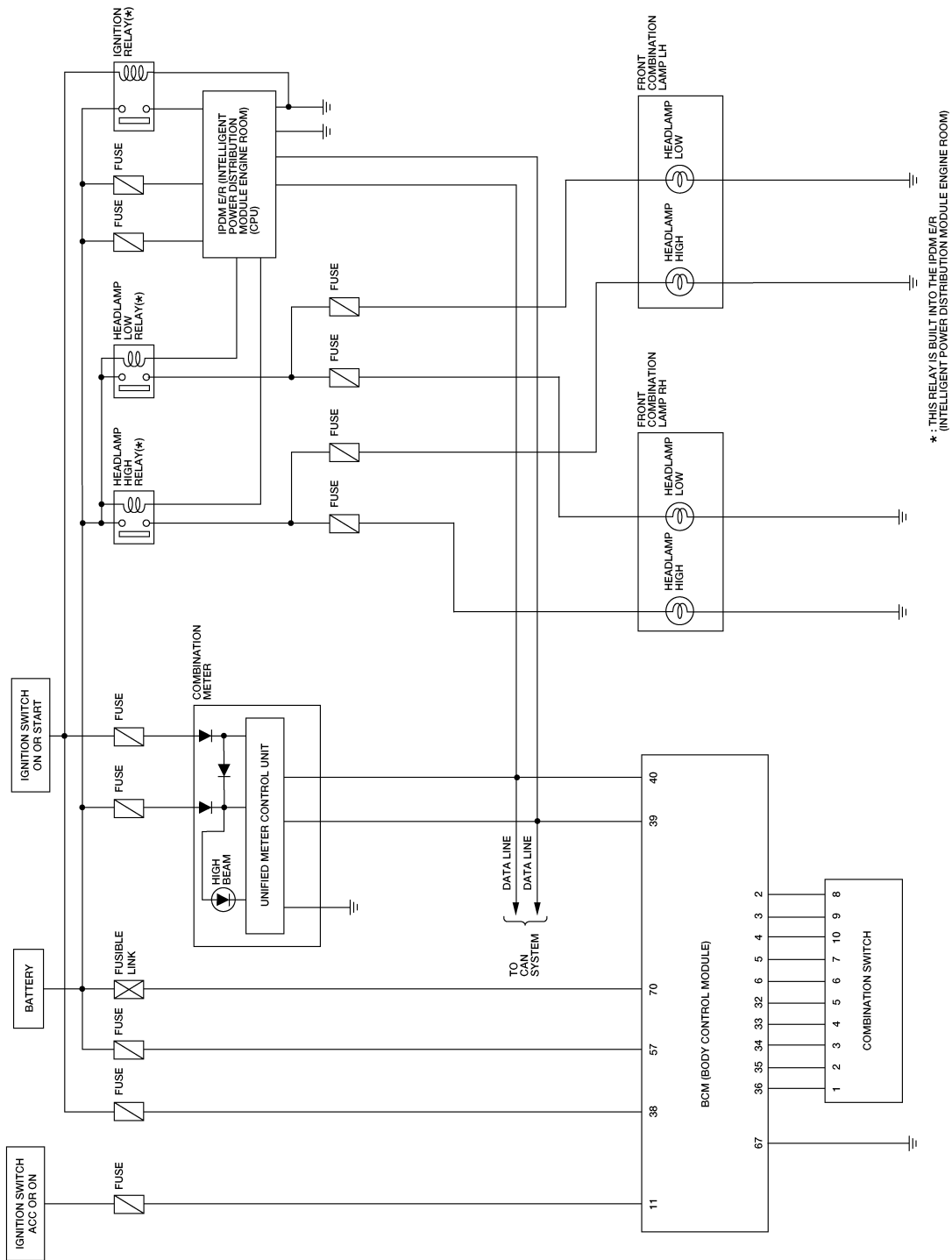

*: THIS RELAY IS BUILT INTO THE IPDM E/R (INTELLIGENT POWER DISTRIBUTION MODULE ENGINE ROOM)

A
B
C
D
E
F
G
H
I
J
LT
L
M
N
O
P

WKWA4679E

HEADLAMP (FOR USA)

< SERVICE INFORMATION >

Wiring Diagram - H/LAMP -

INFOID:000000001719037

LT-H/LAMP-01

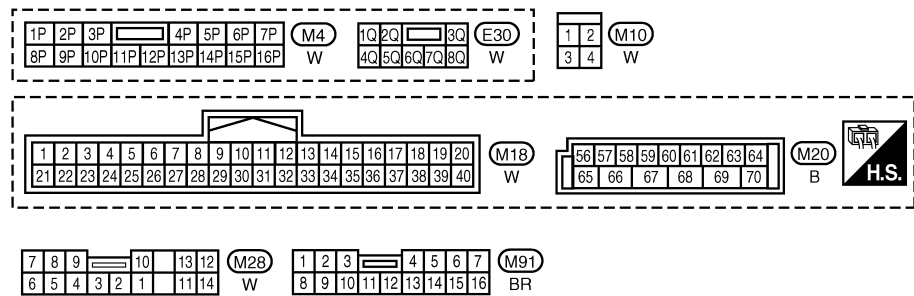
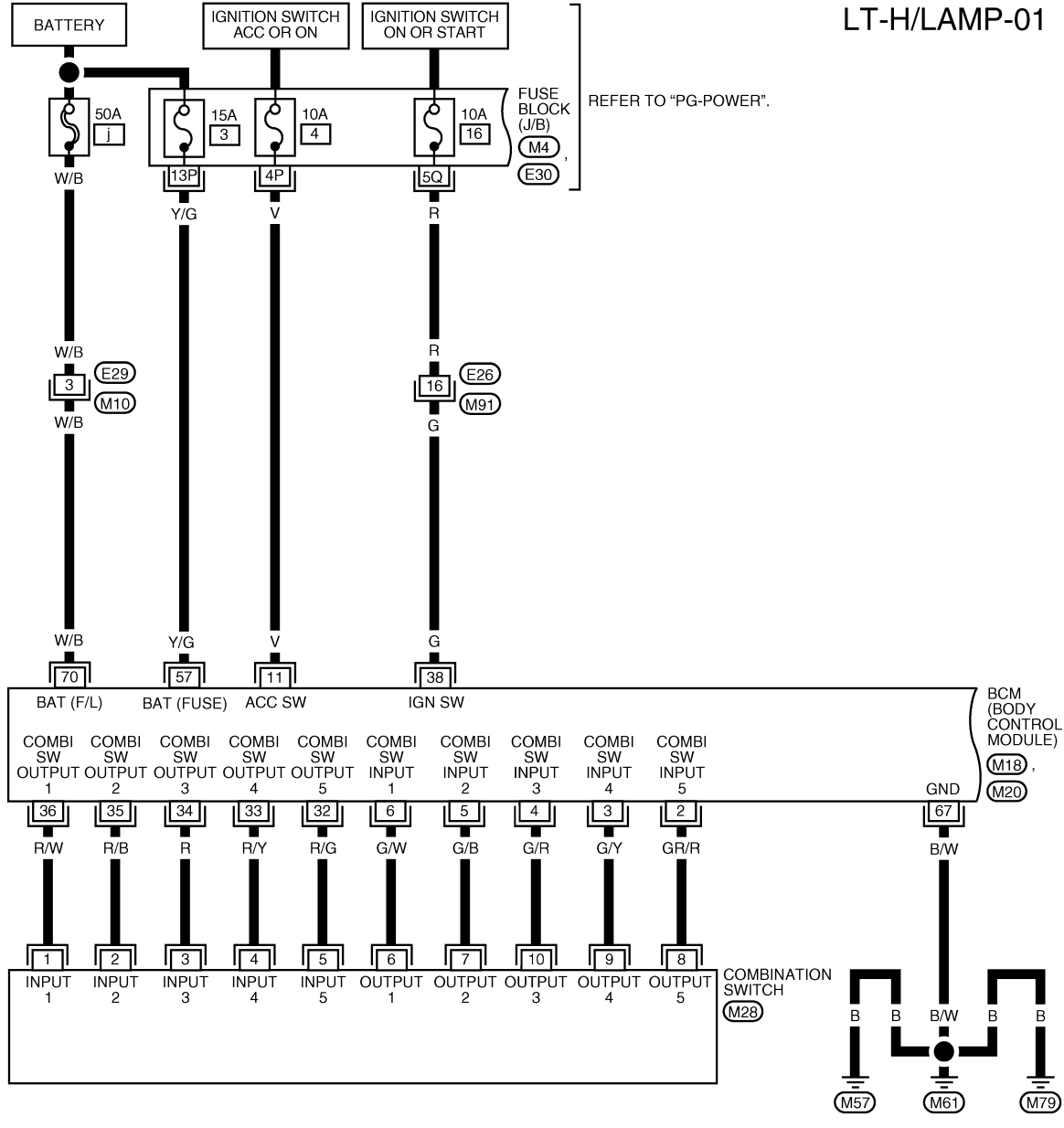

WKWA4680E

HEADLAMP (FOR USA)

< SERVICE INFORMATION >

LT-H/LAMP-02

▬ : DATA LINE

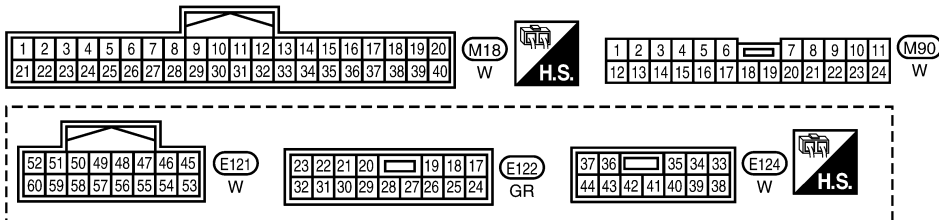
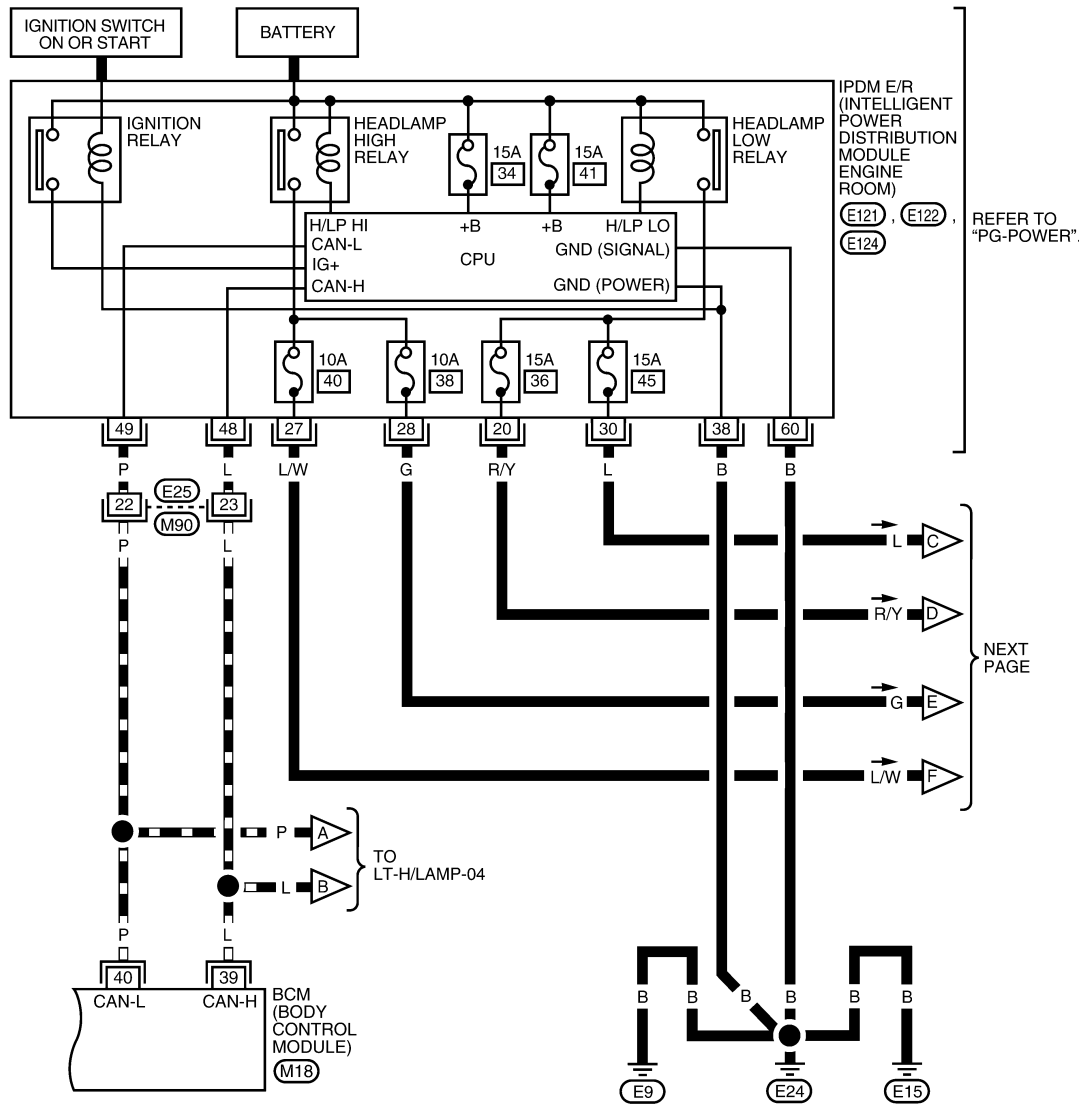

WKWA4681E

HEADLAMP (FOR USA)

< SERVICE INFORMATION >

LT-H/LAMP-03

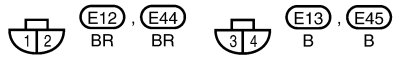
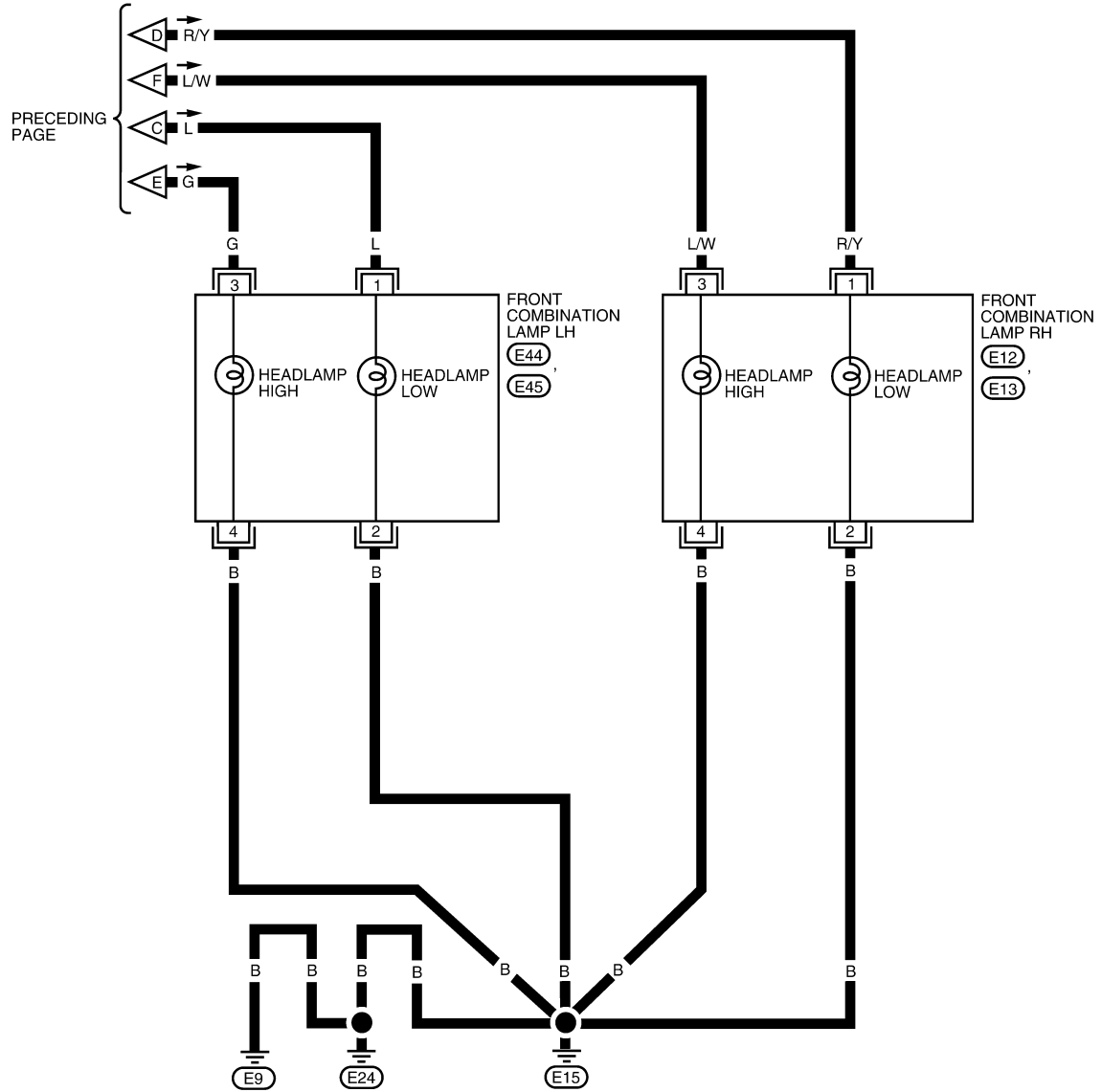

WKWA4682E

HEADLAMP (FOR USA)

< SERVICE INFORMATION >

LT-H/LAMP-04

▬ : DATA LINE

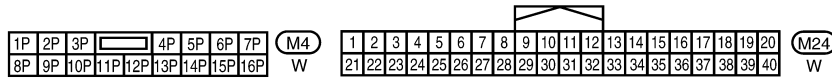
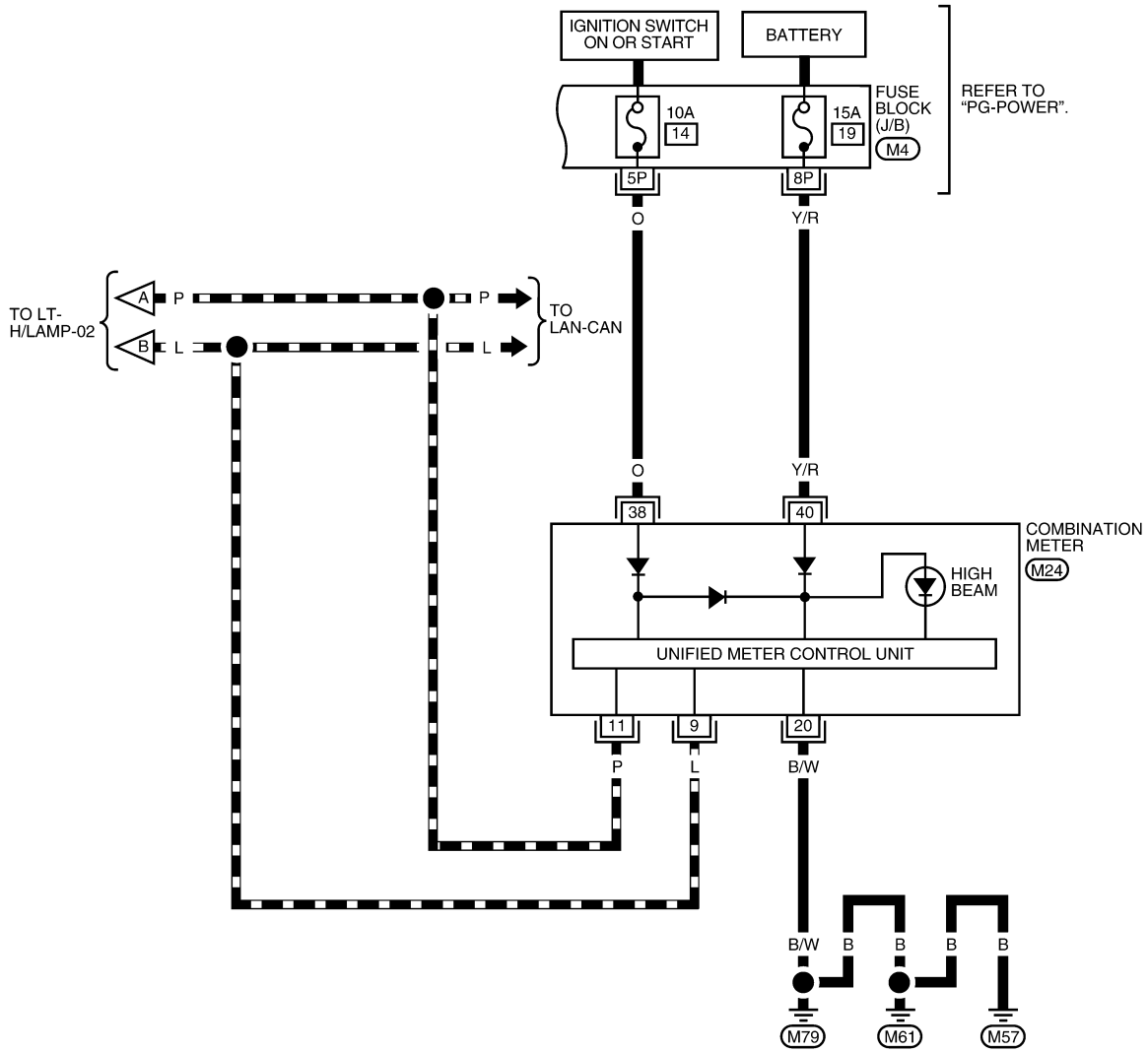

Terminal and Reference Value for BCM

Refer to [BCS-11, "Terminal and Reference Value for BCM"](#).

Terminal and Reference Value for IPDM E/R

Refer to [PG-24, "Terminal and Reference Value for IPDM E/R"](#).

ALLWA0138GB

INFOID:000000001719038

INFOID:000000001719039

HEADLAMP (FOR USA)

< SERVICE INFORMATION >

How to Proceed with Trouble Diagnosis

INFOID:000000001719040

1. Confirm the symptom or customer complaint.
2. Understand operation description and function description. Refer to [LT-5, "System Description"](#).
3. Perform the Preliminary Check. Refer to [LT-12, "Preliminary Check"](#).
4. Check symptom and repair or replace the cause of malfunction.
5. Does the headlamp operate normally? If YES: GO TO 6. If NO: GO TO 4.
6. Inspection End.

Preliminary Check

INFOID:000000001719041

CHECK POWER SUPPLY AND GROUND CIRCUIT

Refer to [BCS-15, "BCM Power Supply and Ground Circuit Inspection"](#).

Refer to [PG-27, "IPDM E/R Power/Ground Circuit Inspection"](#).

CONSULT-III Function (BCM)

INFOID:000000001719042

CONSULT-III can display each diagnostic item using the diagnostic test modes shown following.

BCM diagnostic test item	Diagnostic mode	Description
Inspection by part	WORK SUPPORT	Supports inspections and adjustments. Commands are transmitted to the BCM for setting the status suitable for required operation, input/output signals are received from the BCM and received data is displayed.
	DATA MONITOR	Displays BCM input/output data in real time.
	ACTIVE TEST	Operation of electrical loads can be checked by sending drive signal to them.
	SELF-DIAG RESULTS	Displays BCM self-diagnosis results.
	CAN DIAG SUPPORT MNTR	The result of transmit/receive diagnosis of CAN communication can be read.
	ECU PART NUMBER	BCM part number can be read.
CONFIGURATION	Performs BCM configuration read/write functions.	

WORK SUPPORT

Operation Procedure

1. Touch "HEAD LAMP" on "SELECT TEST ITEM" screen.
2. Touch "WORK SUPPORT" on "SELECT DIAG MODE" screen.
3. Touch item on "SELECT WORK ITEM" screen.
4. Touch "START".
5. Touch "CHANGE SETT".
6. The setting will be changed and "CUSTOMIZING COMPLETED" will be displayed.
7. Touch "END".

Display Item List

Item	Description	CONSULT-III	Factory setting
BATTERY SAVER SET	Exterior lamp battery saver control mode can be changed in this mode. Selects exterior lamp battery saver control mode between ON/OFF.	ON	×
		OFF	—

DATA MONITOR

Operation Procedure

1. Touch "HEAD LAMP" on "SELECT TEST ITEM" screen.
2. Touch "DATA MONITOR" on "SELECT DIAG MODE" screen.
3. Touch either "ALL SIGNALS" or "SELECTION FROM MENU" on the "SELECT MONITOR ITEM" screen.

HEADLAMP (FOR USA)

< SERVICE INFORMATION >

ALL SIGNALS	Monitors all the signals.
SELECTION FROM MENU	Selects and monitors individual signal.

4. Touch "START".
5. When "SELECTION FROM MENU" is selected, touch individual items to be monitored. When "ALL SIGNALS" is selected, all the items will be monitored.
6. Touch "RECORD" while monitoring, then the status of the monitored item can be recorded. To stop recording, touch "STOP".

Display Item List

Monitor item		Contents
IGN ON SW	"ON/OFF"	Displays "IGN position (ON)/OFF, ACC position (OFF)" judged from the ignition switch signal.
ACC ON SW	"ON/OFF"	Displays "ACC (ON)/OFF, Ignition OFF (OFF)" status judged from ignition switch signal.
HI BEAM SW	"ON/OFF"	Displays status (high beam switch: ON/Others: OFF) of high beam switch judged from lighting switch signal.
HEAD LAMP SW 1	"ON/OFF"	Displays status (headlamp switch 1: ON/Others: OFF) of headlamp switch 2 judged from lighting switch signal.
HEAD LAMP SW 2	"ON/OFF"	Displays status (headlamp switch 2: ON/Others: OFF) of headlamp switch 2 judged from lighting switch signal.
LIGHT SW 1ST	"ON/OFF"	Displays status (lighting switch 1st position: ON/Others: OFF) of lighting switch judged from lighting switch signal.
AUTO LIGHT SW	"ON/OFF"	Displays status of the lighting switch as judged from the lighting switch signal. (AUTO position: ON/Other than AUTO position: OFF)
PASSING SW	"ON/OFF"	Displays status (flash-to-pass switch: ON/Others: OFF) of flash-to-pass switch judged from lighting switch signal.
FR FOG SW	"ON/OFF"	Displays status (front fog lamp switch: ON/Others: OFF) of front fog lamp switch judged from lighting switch signal.
DOOR SW-DR	"ON/OFF"	Displays status of the front door LH as judged from the front door switch LH signal. (Door is open: ON/Door is closed: OFF)
DOOR SW-AS	"ON/OFF"	Displays status of the front door RH as judged from the front door switch RH signal. (Door is open: ON/Door is closed: OFF)
DOOR SW-RR	"ON/OFF"	Displays status of the rear door as judged from the rear door switch (RH) signal. (Door is open: ON/Door is closed: OFF)
DOOR SW-RL	"ON/OFF"	Displays status of the rear door as judged from the rear door switch (LH) signal. (Door is open: ON/Door is closed: OFF)
BACK DOOR SW	"ON/OFF"	Displays status of the back door as judged from the back door switch signal. (Door is open: ON/Door is closed: OFF)
TURN SIGNAL R	"ON/OFF"	Displays status (Turn right: ON/Others: OFF) as judged from lighting switch signal.
TURN SIGNAL L	"ON/OFF"	Displays status (Turn left: ON/Others: OFF) as judged from lighting switch signal.
CARGO LAMP SW	"ON/OFF"	Displays status of cargo lamp switch.
OPTICAL SENSOR	[0 - 5V]	Displays "ambient light (close to 5V when dark/close to 0V when light)" judged from optical sensor signal.

ACTIVE TEST

Operation Procedure

1. Touch "HEAD LAMP" on "SELECT TEST ITEM" screen.
2. Touch "ACTIVE TEST" on "SELECT DIAG MODE" screen.
3. Touch item to be tested, and check operation of the selected item.
4. During the operation check, touching "BACK" deactivates the operation.

Display Item List

HEADLAMP (FOR USA)

< SERVICE INFORMATION >

Test item	Description
TAIL LAMP	Allows tail lamp relay to operate by switching ON-OFF.
HEAD LAMP	Allows headlamp relay (HI, LO) to operate by switching ON-OFF.
FR FOG LAMP	Allows fog lamp relay to operate by switching ON-OFF.
CARGO LAMP	Allows cargo lamp to operate by switching ON-OFF.
CORNERING LAMP	Allows cornering lamp relay (RH, LH) to operate by switching ON-OFF.

SELF-DIAGNOSTIC RESULTS

Operation Procedure

1. Touch "BCM" on "SELECT TEST ITEM" screen.
2. Touch "SELF-DIAG RESULTS" on "SELECT DIAG MODE" screen.
3. Self-diagnostic results are displayed.

Display Item List

Monitored item	CONSULT-II display	Description
CAN communication	CAN communication [U1000]	Malfunction is detected in CAN communication.
CAN communication system	CAN communication system 1 to 6 [U1000]	Malfunction is detected in CAN system.

CONSULT-III Function (IPDM E/R)

INFOID:000000001719043

CONSULT-III can display each diagnostic item using the diagnostic test modes shown following.

IPDM E/R diagnostic Mode	Description
SELF-DIAG RESULTS	Displays IPDM E/R self-diagnosis results.
DATA MONITOR	Displays IPDM E/R input/output data in real time.
CAN DIAG SUPPORT MNTR	The result of transmit/receive diagnosis of CAN communication can be read.
ACTIVE TEST	Operation of electrical loads can be checked by sending drive signal to them.

DATA MONITOR

Operation Procedure

1. Touch "DATA MONITOR" on "SELECT DIAG MODE" screen.
2. Touch "ALL SIGNALS", "MAIN SIGNALS" or "SELECTION FROM MENU" on the "SELECT MONITOR ITEM" screen.

ALL SIGNALS	All items will be monitored.
MAIN SIGNALS	Monitor the predetermined item.
SELECTION FROM MENU	Select any item for monitoring.

3. Touch "START".
4. Touch the required monitoring item on "SELECTION FROM MENU". In "ALL SIGNALS", all items are monitored. In "MAIN SIGNALS", predetermined items are monitored.
5. Touch "RECORD" while monitoring to record the status of the item being monitored. To stop recording, touch "STOP".

All Signals, Main Signals, Selection From Menu

HEADLAMP (FOR USA)

< SERVICE INFORMATION >

Item name	CONSULT-III screen display	Display or unit	Monitor item selection			Description
			ALL SIGNALS	MAIN SIGNALS	SELECTION FROM MENU	
Parking, license plate and tail lamps request	TAIL&CLR REQ	ON/OFF	×	×	×	Signal status input from BCM
Headlamp low beam request	HL LO REQ	ON/OFF	×	×	×	Signal status input from BCM
Headlamp high beam request	HL HI REQ	ON/OFF	×	×	×	Signal status input from BCM
Cornering lamp	CRNRNG LMP REQ	ON/OFF	×	–	×	Signal status input from BCM
Front fog lamps request	FR FOG REQ	ON/OFF	×	×	×	Signal status input from BCM

NOTE:

Perform monitoring of IPDM E/R data with the ignition switch ON. When the ignition switch is at ACC, the display may not be correct.

ACTIVE TEST

Operation Procedure

1. Touch "ACTIVE TEST" on "SELECT DIAG MODE" screen.
2. Touch item to be tested and check operation.
3. Touch "START".
4. Touch "STOP" while testing to stop the operation.

Test item	CONSULT-III screen display	Description
Tail lamp relay output	TAIL LAMP	Allows tail lamp relay to operate by switching operation ON-OFF at your option.
Headlamp relay (HI, LO) output	LAMPS	Allows headlamp relay (HI, LO) to operate by switching operation (OFF, HI, LO) at your option (Head lamp high beam repeats ON-OFF every 1 second).
Front fog lamp relay (FOG) output		Allows fog lamp relay (FOG) to operate by switching operation ON-OFF at your option.
Cornering lamp relay (RH, LH) output	CORNERING LAMP	Allows cornering lamp relay (RH, LH) to operate by switching operation ON-OFF at your option.

Headlamp HI Does Not Illuminate (Both Sides)

INFOID:000000001719044

1. CHECK COMBINATION SWITCH INPUT SIGNAL

Select "BCM" on CONSULT-III. With "HEAD LAMP" data monitor, make sure "HI BEAM SW" turns ON-OFF linked with operation of lighting switch.

**When lighting switch is in : HI BEAM SW ON
HIGH position**

OK or NG

OK >> GO TO 2.

NG >> Check lighting switch. Refer to [LT-81, "Combination Switch Inspection"](#).

2. HEADLAMP ACTIVE TEST

1. Select "IPDM E/R" on CONSULT-III, and select "ACTIVE TEST" on "SELECT DIAG MODE" screen.
2. Select "LAMPS" on "SELECT TEST ITEM" screen.
3. Touch "HI" on "ACTIVE TEST" screen.
4. Make sure headlamp high beam operates.

Headlamp high beam should operate.

OK or NG

HEADLAMP (FOR USA)

< SERVICE INFORMATION >

- OK >> GO TO 3.
 NG >> GO TO 4.

3.CHECK IPDM E/R

1. Select "IPDM E/R" on CONSULT-III, and select "DATA MONITOR" on "SELECT DIAG MODE" screen.
2. Make sure "HL LO REQ" and "HL HI REQ" turns ON when lighting switch is in HIGH position.

When lighting switch is in HIGH position : HL LO REQ ON
 : HL HI REQ ON

OK or NG

- OK >> Replace IPDM E/R. Refer to [PG-28, "Removal and Installation of IPDM E/R"](#).
 NG >> Replace BCM. Refer to [BCS-18, "Removal and Installation of BCM"](#).

4.CHECK HEADLAMP INPUT SIGNAL

1. Turn ignition switch OFF.
2. Disconnect front combination lamp RH and LH connectors.
3. Turn ignition switch ON.
4. Select "IPDM E/R" on CONSULT-III, and select "ACTIVE TEST" on "SELECT DIAG MODE" screen.
5. Select "LAMPS" on "SELECT TEST ITEM" screen.
6. Touch "HI" on "ACTIVE TEST" screen.
7. When headlamp high beam is operating, check voltage between front combination lamp RH and LH harness connector terminals and ground.

Terminals		Terminal	(-)	Voltage
(+)				
Front combination lamp connector		3	Ground	Battery voltage
RH	E13			
LH	E45			

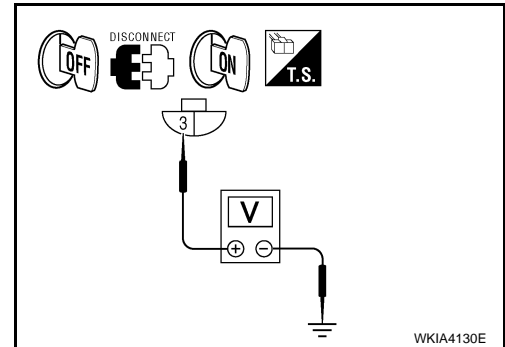

OK or NG

- OK >> GO TO 6.
 NG >> GO TO 5.

5.CHECK HEADLAMP CIRCUIT

1. Turn ignition switch OFF.
2. Disconnect IPDM E/R connector.
3. Check continuity between IPDM E/R harness connector terminals and front combination lamp RH and LH harness connector terminals.

A		B		Continuity
IPDM E/R connector	Terminal	Front combination lamp connector	Terminal	
E122	27	RH	E13	Yes
	28	LH	E45	

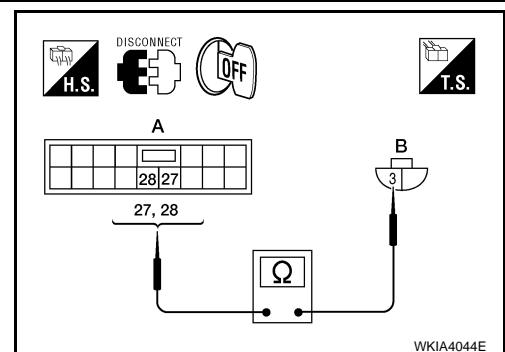

OK or NG

- OK >> Replace IPDM E/R. Refer to [PG-28, "Removal and Installation of IPDM E/R"](#).
 NG >> Repair harness or connector.

6.CHECK HEADLAMP GROUND

1. Turn ignition switch OFF.

HEADLAMP (FOR USA)

< SERVICE INFORMATION >

- Check continuity between front combination lamp RH and LH harness connector terminals and ground.

Terminals		Terminal		Continuity
Front combination lamp connector				
RH	E13	4	Ground	Yes
LH	E45			

OK or NG

- OK >> Check front combination lamp connector for damage or poor connection. Repair as necessary.
 NG >> Repair harness or connector.

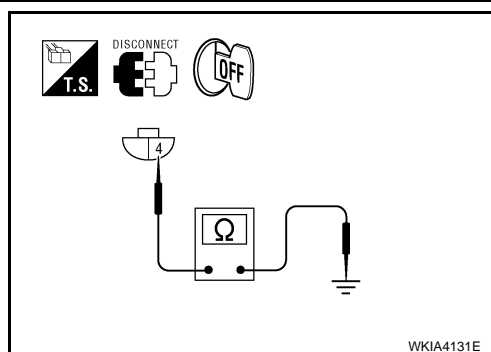

Headlamp HI Does Not Illuminate (One Side)

INFOID:000000001719045

1. BULB INSPECTION

Inspect inoperative headlamp bulb.

OK or NG

- OK >> GO TO 2.
 NG >> Replace headlamp bulb. Refer to [LT-22, "Bulb Replacement"](#).

2. CHECK POWER TO HEADLAMP

- Disconnect inoperative front combination lamp connector.
- Turn the high beam headlamps ON.
- Check voltage between inoperative front combination lamp harness connector terminal and ground.

Terminals		Terminal	(-)	Voltage (Approx.)
Front combination lamp connector				
(+)		3	Ground	Battery voltage
RH	E13			
LH	E45			

OK or NG

- OK >> GO TO 3.
 NG >> GO TO 4.

3. CHECK HEADLAMP GROUND

- Turn the high beam headlamps OFF.
- Check continuity between inoperative front combination lamp harness connector terminal and ground.

Terminals		Terminal		Continuity
Front combination lamp connector				
RH	E13	4	Ground	Yes
LH	E45			

OK or NG

- OK >> Check front combination lamp connector for damage or poor connection. Repair as necessary.
 NG >> Repair open circuit in harness between inoperative headlamp and ground.

4. INSPECTION BETWEEN IPDM E/R AND HEADLAMPS

- Disconnect IPDM E/R connector.

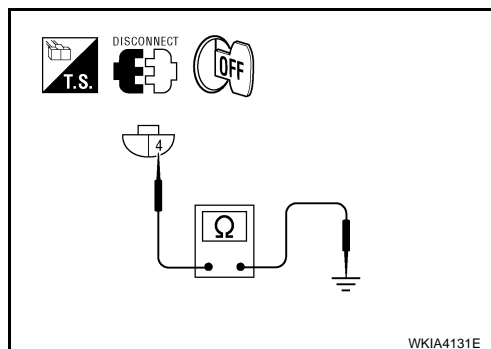
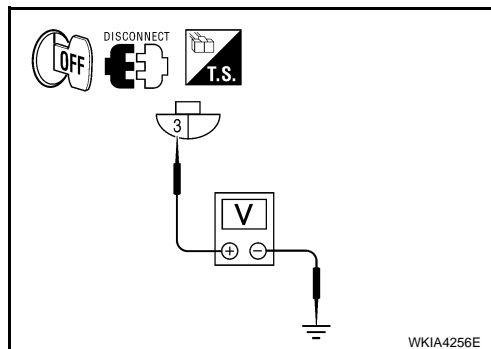

HEADLAMP (FOR USA)

< SERVICE INFORMATION >

- Check continuity between IPDM E/R harness connector terminal and inoperative front combination lamp harness connector terminal.

A		B		Continuity	
IPDM E/R connector	Terminal	Front combination lamp connector	Terminal		
E122	27	RH	E13	3	Yes
	28	LH	E45		

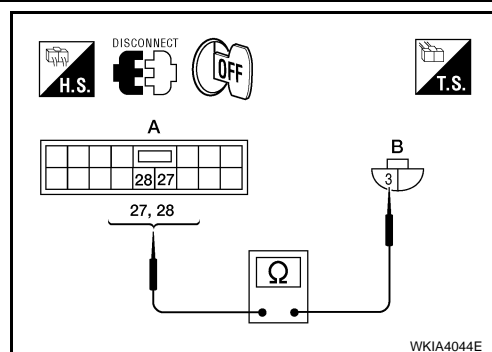

OK or NG

- OK >> Replace IPDM E/R. Refer to [PG-28, "Removal and Installation of IPDM E/R"](#).
- NG >> Check for short circuits and open circuits in harness between IPDM E/R and headlamps. Repair as necessary.

High-Beam Indicator Lamp Does Not Illuminate

INFOID:000000001719046

1. CAN COMMUNICATION SYSTEM INSPECTION

Inspect CAN communication system. Refer to [LAN-38](#).

OK or NG

- OK >> Replace combination meter. Refer to [DI-22, "Combination Meter"](#).
- NG >> Repair as necessary.

Headlamp LO Does Not Illuminate (Both Sides)

INFOID:000000001719047

1. CHECK COMBINATION SWITCH INPUT SIGNAL

Select "BCM" on CONSULT-III. With "HEAD LAMP" data monitor, make sure "HEAD LAMP SW 1" and "HEAD LAMP SW 2" turns ON-OFF linked with operation of lighting switch.

When lighting switch is in 2ND position :
HEAD LAMP SW 1 ON
HEAD LAMP SW 2 ON

OK or NG

- OK >> GO TO 2.
- NG >> Check lighting switch. Refer to [LT-81, "Combination Switch Inspection"](#).

2. HEADLAMP ACTIVE TEST

- Select "IPDM E/R" on CONSULT-III, and select "ACTIVE TEST" on "SELECT DIAG MODE" screen.
- Select "LAMPS" on "SELECT TEST ITEM" screen.
- Touch "LO" on "ACTIVE TEST" screen.
- Make sure headlamp low beam operates.

Headlamp low beam should operate.

OK or NG

- OK >> GO TO 3.
- NG >> GO TO 4.

3. CHECK IPDM E/R

- Select "IPDM E/R" on CONSULT-III, and select "DATA MONITOR" on "SELECT DIAG MODE" screen.
- Make sure "HL LO REQ" turns ON when lighting switch is in 2ND position.

When lighting switch is in 2ND position :
HL LO REQ ON

OK or NG

- OK >> Replace IPDM E/R. Refer to [PG-28, "Removal and Installation of IPDM E/R"](#).
- NG >> Replace BCM. Refer to [BCS-18, "Removal and Installation of BCM"](#).

HEADLAMP (FOR USA)

< SERVICE INFORMATION >

4. CHECK HEADLAMP INPUT SIGNAL

1. Turn ignition switch OFF.
2. Disconnect front combination lamp RH and LH connectors.
3. Turn ignition switch ON.
4. Select "IPDM E/R" on CONSULT-III, and select "ACTIVE TEST" on "SELECT DIAG MODE" screen.
5. Select "LAMPS" on "SELECT TEST ITEM" screen.
6. Touch "LO" on "ACTIVE TEST" screen.
7. When headlamp low beam is operating, check voltage between front combination lamp RH and LH harness connectors and ground.

Terminals		Terminal	(-)	Voltage
(+)				
Front combination lamp connector		1	Ground	Battery voltage
RH	E12			
LH	E44			

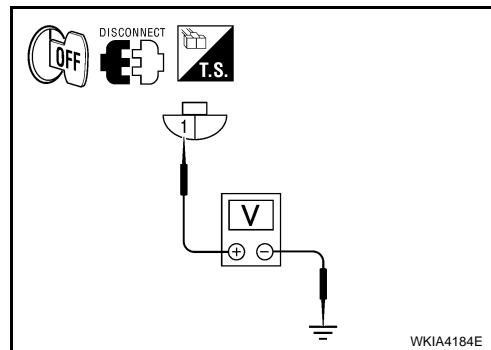

OK or NG

- OK >> GO TO 6.
 NG >> GO TO 5.

5. CHECK HEADLAMP CIRCUIT

1. Turn ignition switch OFF.
2. Disconnect IPDM E/R connector.
3. Check continuity between IPDM E/R harness connector terminal and front combination lamp harness connector terminal.

A		B		Continuity
IPDM E/R connector	Terminal	Front combination lamp connector	Terminal	
E122	20	RH	E12	Yes
	30	LH	E44	

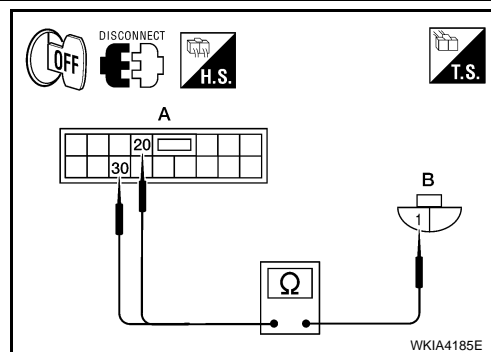

OK or NG

- OK >> Replace IPDM E/R. Refer to [PG-28, "Removal and Installation of IPDM E/R"](#).
 NG >> Repair harness or connector.

6. CHECK HEADLAMP GROUND

1. Turn ignition switch OFF.
2. Check continuity between front combination lamp harness connector terminal and ground.

Terminals		Terminal	Ground	Voltage
Front combination lamp connector				
RH	E12	2	Ground	Battery voltage
LH	E44			

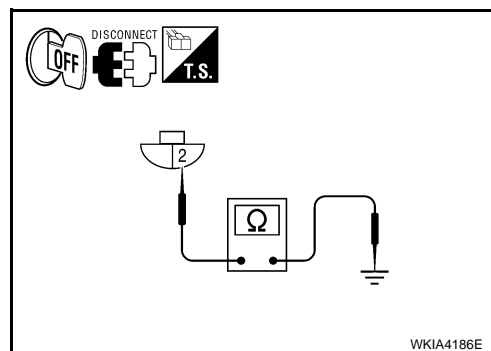

OK or NG

- OK >> Check front combination lamp connector for damage or poor connection. Repair as necessary.
 NG >> Repair harness or connector.

HEADLAMP (FOR USA)

< SERVICE INFORMATION >

Headlamp LO Does Not Illuminate (One Side)

INFOID:000000001719048

1. BULB INSPECTION

Inspect inoperative headlamp bulb.

OK or NG

OK >> GO TO 2.

NG >> Replace headlamp bulb. Refer to [LT-22. "Bulb Replacement"](#).

2. CHECK POWER TO HEADLAMP

1. Disconnect inoperative front combination lamp connector.
2. Turn the low beam headlamps ON.
3. Check voltage between inoperative front combination lamp connector terminal and ground.

Terminals		Terminal	(-)	Voltage (Approx.)
(+)				
Front combination lamp connector		1	Ground	Battery voltage
RH	E12			
LH	E44			

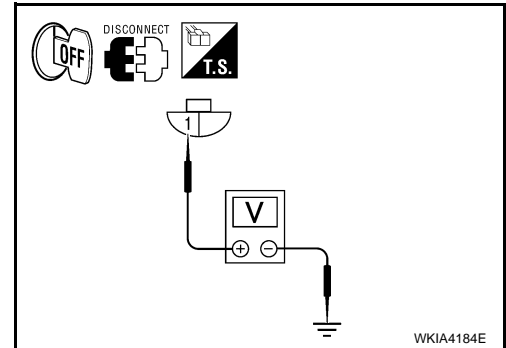

OK or NG

OK >> GO TO 3.

NG >> GO TO 4.

3. CHECK HEADLAMP GROUND

1. Turn the low beam headlamps OFF.
2. Check continuity between inoperative front combination lamp connector terminal and ground.

Terminals		Terminal	(-)	Continuity
(+)				
Front combination lamp connector		2	Ground	Yes
RH	E12			
LH	E44			

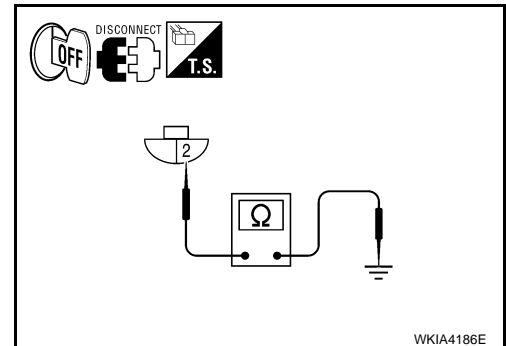

OK or NG

OK >> Check headlamp and IPDM E/R connector. Repair as necessary.

NG >> Repair open circuit in harness between inoperative headlamp and ground.

4. INSPECTION BETWEEN IPDM E/R AND HEADLAMPS

1. Disconnect IPDM E/R connector.
2. Check continuity between IPDM E/R harness connector terminals and inoperative front combination lamp harness connector terminals.

A		B		Continuity
IPDM E/R connector	Terminal	Front combination lamp connector	Terminal	
E122	20	RH	E12	Yes
	30	LH	E44	

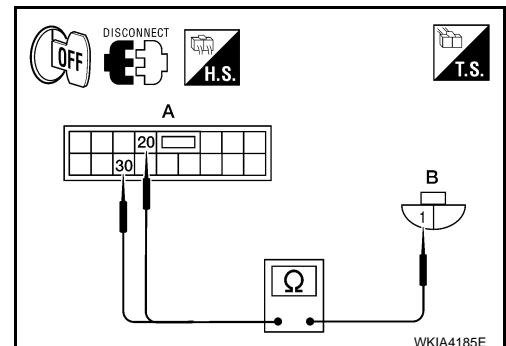

OK or NG

OK >> Replace IPDM E/R. Refer to [PG-28. "Removal and Installation of IPDM E/R"](#).

HEADLAMP (FOR USA)

< SERVICE INFORMATION >

NG >> Check for short circuits and open circuits in harness between IPDM E/R and headlamps. Repair as necessary.

Headlamps Do Not Turn OFF

INFOID:000000001719049

1. CHECK COMBINATION SWITCH INPUT SIGNAL

Select "BCM" on CONSULT-III. With "HEAD LAMP" data monitor, make sure "HEAD LAMP SW 1" and "HEAD LAMP SW 2" turns ON-OFF linked with operation of lighting switch.

When lighting switch is in OFF position : HEAD LAMP SW 1 OFF
: HEAD LAMP SW 2 OFF

OK or NG

OK >> Replace IPDM E/R. Refer to [PG-28, "Removal and Installation of IPDM E/R"](#).

NG >> GO TO 2.

2. CHECK LIGHTING SWITCH

Check lighting switch. Refer to [LT-81, "Combination Switch Inspection"](#).

OK or NG

OK >> GO TO 3.

NG >> Replace lighting switch. Refer to [LT-83, "Removal and Installation"](#).

3. CHECKING CAN COMMUNICATIONS BETWEEN BCM AND IPDM E/R

Select "BCM" on CONSULT-III and perform self-diagnosis for BCM.

Display of self-diagnosis results

NO DTC>>Replace IPDM E/R. Refer to [PG-28, "Removal and Installation of IPDM E/R"](#).

CAN COMM CIRCUIT>> Refer to [BCS-17, "CAN Communication Inspection Using CONSULT-III \(Self-Diagnosis\)"](#).

Aiming Adjustment

INFOID:000000001719050

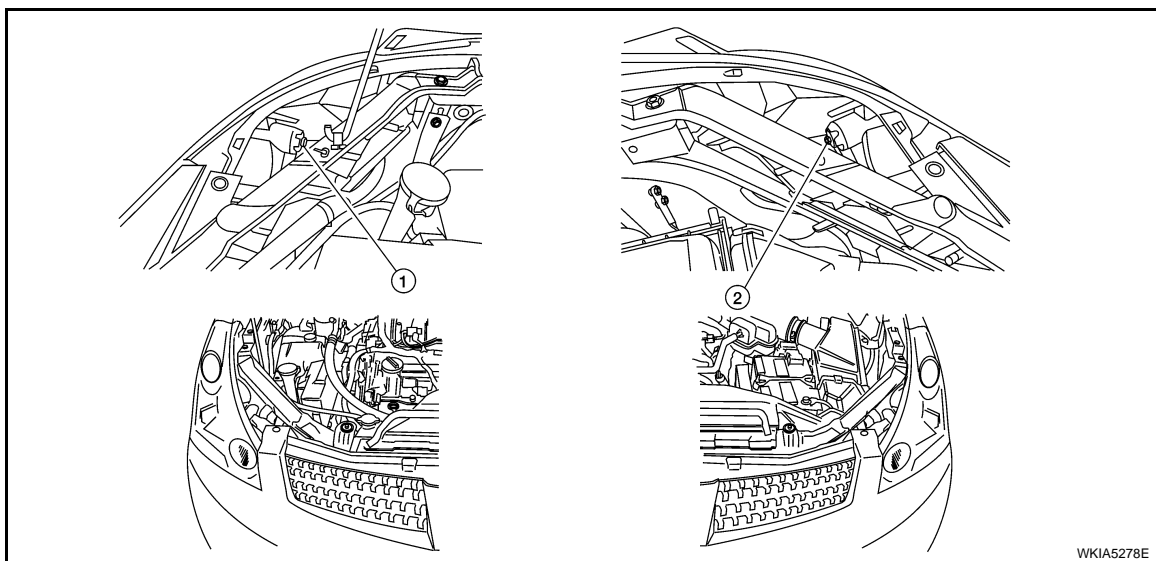

1. RH headlamp (low beam) adjustment screw 2. LH headlamp (low beam) adjustment screw

For details, refer to the regulations in your area.

NOTE:

If vehicle front body has been repaired and /or the headlamp assembly has been replaced, check headlamp aiming.

HEADLAMP AIMING

NOTE:

HEADLAMP (FOR USA)

< SERVICE INFORMATION >

- Before performing aiming adjustment, check the following:
 - Confirm headlamp aiming switch is set to "0" (zero) position (if equipped).
 - Ensure all tires are inflated to correct pressure.
 - Place vehicle and screen on level surface.
 - Ensure there is no load in vehicle other than the driver (or equivalent weight placed in driver's position). Coolant and engine oil filled to correct level, and fuel tank full.
 - Confirm spare tire, jack and tools are properly stowed.
 - Use adjusting screw to perform aiming adjustment.

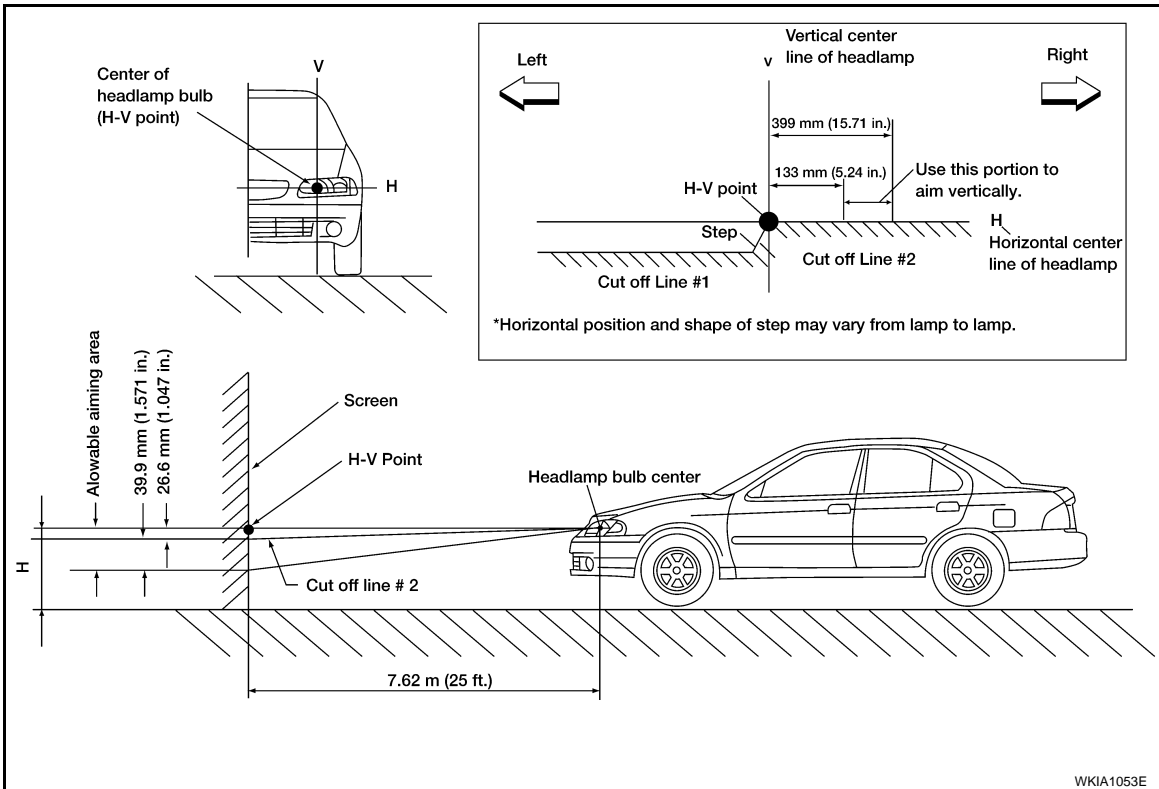

- **Basic illuminating area for adjustment should be within the range shown on the aiming chart. Adjust headlamps accordingly.**

LOW BEAM AND HIGH BEAM

NOTE:

Aim each headlamp individually and ensure other headlamp beam pattern is blocked from screen.

1. Turn headlamp low beam on.
2. Use adjusting screw to perform aiming adjustment.

Bulb Replacement

INFOID:000000001719051

CAUTION:

- Do not touch bulb by hand right after being turned off. Burning may result.
- Do not touch the glass of bulb directly by hand. Keep grease and other oily substances away from it.
- Do not leave bulb out of front combination lamp assembly for a long time because dust, moisture, smoke, etc. may affect the performance of the lamp. When replacing headlamp bulb, be sure to replace it with a new one.
- After installing the bulb, be sure to install the bulb socket securely to ensure watertightness.

HEADLAMP (OUTER SIDE), FOR LOW BEAM

Removal

1. Turn headlamp switch OFF.
2. Disconnect the electrical connector.
3. Turn bulb socket counterclockwise and remove bulb.

HEADLAMP (FOR USA)

< SERVICE INFORMATION >

Installation

Installation is in the reverse order of removal.

HEADLAMP (INNER SIDE), FOR HIGH BEAM

Removal

1. Turn headlamp switch OFF.
2. Disconnect the electrical connector.
3. Turn bulb socket counterclockwise and remove bulb.

Installation

Installation is in the reverse order of removal.

FRONT TURN SIGNAL/PARKING LAMP

Removal

1. Turn the front turn signal/parking lamp bulb socket counterclockwise to unlock it.
2. Pull bulb to remove it from socket.

Installation

Installation is in the reverse order of removal.

Removal and Installation

INFOID:000000001719052

FRONT COMBINATION LAMP

Removal

1. Remove front fascia. Refer to [EI-13, "Removal and Installation"](#).
2. Remove front combination lamp bolts.

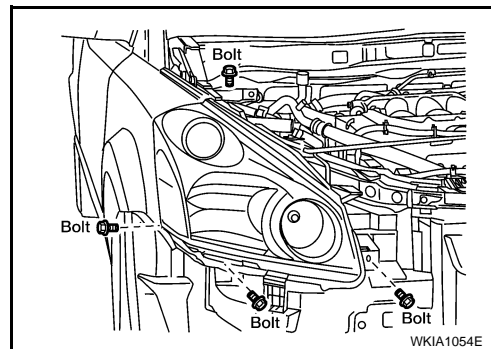

3. Pull front combination lamp toward front of the vehicle, disconnect connectors, and remove front combination lamp.

Installation

1. Connect front combination lamp connectors.
2. Install front combination lamp bolts.

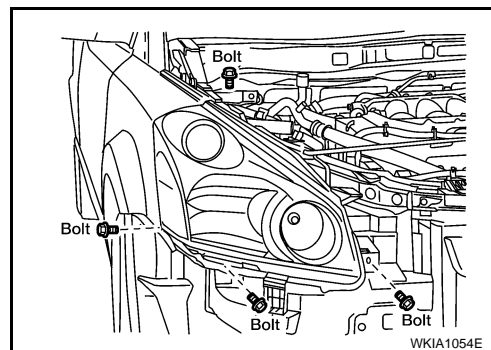

3. Install front fascia. Refer to [EI-13, "Removal and Installation"](#).
4. Verify headlamp aiming. Refer to [LT-21, "Aiming Adjustment"](#).

A
B
C
D
E
F
G
H
I
J
LT
L
M
N
O
P

HEADLAMP (FOR USA)

< SERVICE INFORMATION >

Disassembly and Assembly

INFOID:000000001719053

FRONT COMBINATION LAMP

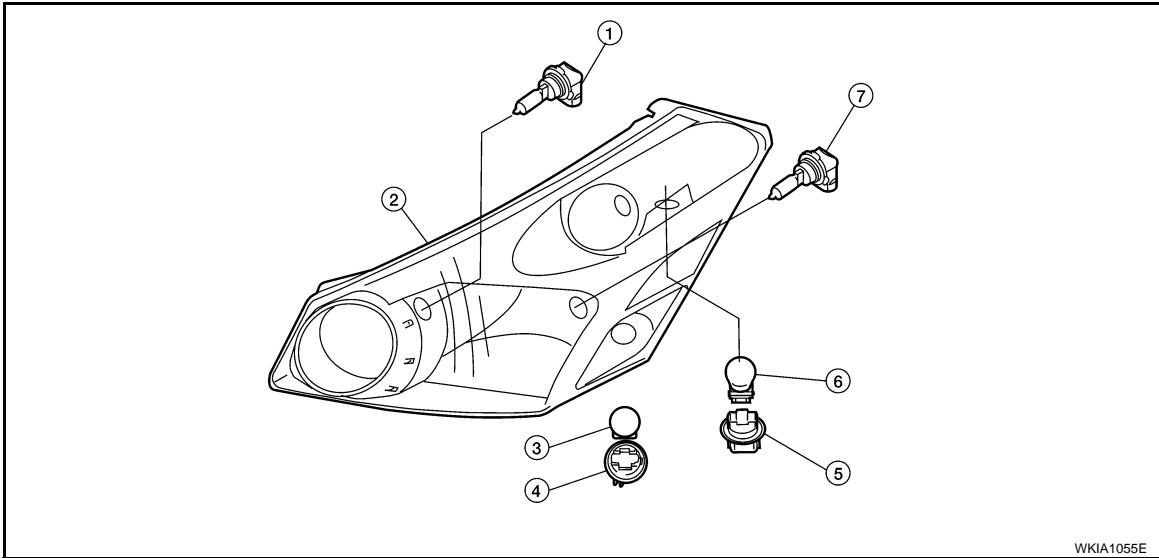

- | | | |
|-------------------------------|-----------------------------------------|----------------------------------|
| 1. Headlamp bulb (High beam) | 2. Headlamp assembly | 3. Cornering lamp bulb |
| 4. Cornering lamp bulb socket | 5. Parking/turn signal lamp bulb socket | 6. Parking/turn signal lamp bulb |
| 7. Headlamp bulb (Low beam) | | |

Disassembly

1. Turn high beam bulb counterclockwise to unlock and remove high beam bulb.
2. Turn low beam bulb counterclockwise to unlock and remove low beam bulb.
3. Turn turn signal/parking lamp (front) bulb socket counterclockwise to unlock and remove turn signal/parking lamp (front) bulb.
4. Turn cornering lamp bulb socket counterclockwise to unlock and remove cornering lamp bulb.

Assembly

Assembly is in the reverse order of disassembly.

HEADLAMP (FOR CANADA) - DAYTIME LIGHT SYSTEM -

< SERVICE INFORMATION >

HEADLAMP (FOR CANADA) - DAYTIME LIGHT SYSTEM -

Component Parts and Harness Connector Location

INFOID:000000001719054

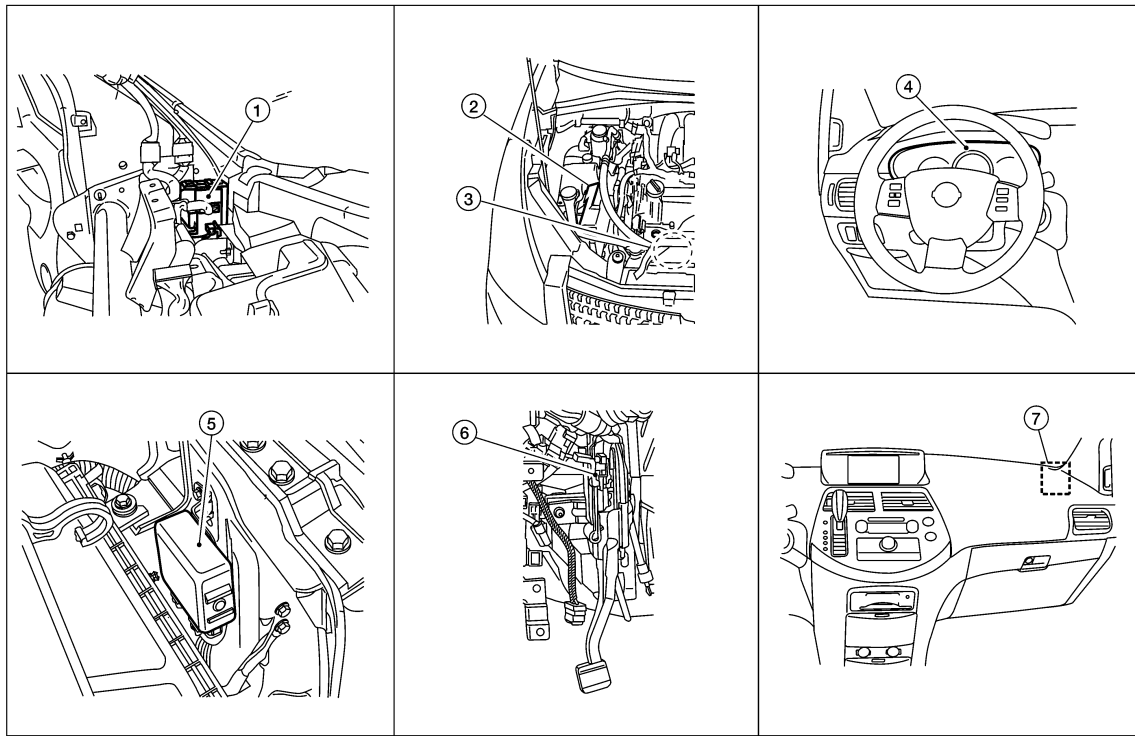

WKIA5260E

- | | | |
|------------------------------------------------------|------------------------------------------|------------------------------|
| 1. BCM M18, M20 (view with instrument panel removed) | 2. IPDM E/R E121, E122, E124 | 3. Generator F1, E112 |
| 4. Combination meter M24 | 5. Daytime light control unit E103, E104 | 6. Parking brake switch E140 |
| 7. Daytime light relay E148 | | |

System Description

INFOID:000000001719055

The headlamp system for Canada vehicles is equipped with a daytime light control unit that activates the high beam headlamps at approximately half illumination whenever the engine is running and the lighting switch is in the OFF or 1st position. If the parking brake is applied before the engine is started the daytime lights will not be illuminated. The daytime lights will illuminate once the parking brake is released. Thereafter, the daytime lights will continue to operate when the parking brake is applied.

Power is supplied at all times

- to ignition relay, located in the IPDM E/R (intelligent power distribution module engine room), and
- to headlamp high relay, located in the IPDM E/R, and
- to headlamp low relay, located in the IPDM E/R, and
- through 50A fusible link (letter j, located in the fuse and fusible link box)
- to BCM terminal 70, and
- through 15A fuse [No. 3, located in the fuse block (J/B)]
- to BCM terminal 57, and
- through 15A fuse (No. 29, located in the fuse and fusible link box)
- to daytime light control unit terminals 2 and 3, and
- through 15A fuse (No. 34, located in the IPDM E/R)
- to CPU in the IPDM E/R, and
- through 15A fuse (No. 41, located in the IPDM E/R)
- to CPU in the IPDM E/R.

With the ignition switch in the ON or START position, power is supplied

- through 10A fuse [No. 12, located in the fuse block (J/B)]
- to daytime light control unit terminal 12, and

HEADLAMP (FOR CANADA) - DAYTIME LIGHT SYSTEM -

< SERVICE INFORMATION >

- through 10A fuse [No. 16, located in the fuse block (J/B)]
- to BCM terminal 38.

With the ignition switch in the ACC or ON position, power is supplied

- through 10A fuse [No. 4, located in the fuse block (J/B)]
- to BCM terminal 11.

With the ignition switch in the START position, power is supplied

- through 10A fuse [No. 9, located in the fuse block (J/B)]
- to daytime light control unit terminal 1.

Ground is supplied

- to IPDM E/R terminals 38 and 60, and
- to daytime light control unit terminal 9
- through grounds E9, E15 and E24, and
- to BCM terminal 67
- through grounds M57, M61 and M79.

HEADLAMP OPERATION

Low Beam Operation

With the lighting switch in 2ND position, the BCM receives input requesting the headlamps to illuminate. This input is communicated to the IPDM E/R across the CAN communication lines. The CPU (central processing unit) of the IPDM E/R controls the headlamp low relay coil. When energized, this relay directs power

- through 15A fuse (No. 45, located in the IPDM E/R)
- through IPDM E/R terminal 30, and
- to front combination lamp LH terminal 1, and
- to daytime light control unit terminal 4
- through 15A fuse (No. 36, located in the IPDM E/R)
- through IPDM E/R terminal 20
- to front combination lamp RH terminal 1, and
- through diode 3
- to daytime light control unit terminal 1.

Ground is supplied

- to front combination lamp LH and RH terminal 2
- through grounds E9, E15 and E24.

With power and ground supplied, low beam headlamps illuminate.

High Beam Operation/Flash-to-Pass Operation

With the lighting switch in 2ND position and placed in HIGH or PASS position, the BCM receives input requesting the headlamp high beams to illuminate. This input is communicated to the IPDM E/R across the CAN communication lines. The CPU of the combination meter controls the ON/OFF status of the HIGH BEAM indicator. The CPU of the IPDM E/R controls the headlamp high relay coil. When energized, this relay directs power

- through 10A fuse (No. 40, located in the IPDM E/R)
 - through IPDM E/R terminal 27
 - to daytime light relay terminal 2, and
 - through diode-3
 - to daytime light control unit terminal 1, and
- When energized, the daytime light relay directs power
- through daytime light relay terminal 3
 - to daytime light control unit terminal 8 and
 - to front combination lamp RH terminal 3.

Also when the headlamp high relay is energized, it directs power

- through 10A fuse (No. 38, located in the IPDM E/R)
- through IPDM E/R terminal 28
- to daytime light control unit terminal 5
- through daytime light control unit terminal 6
- to front combination lamp LH terminal 3.

Ground is supplied

- to front combination lamp RH terminal 4
- through grounds E9, E15 and E24, and
- to front combination lamp LH terminal 4
- to daytime light control unit terminal 7
- through daytime light control unit terminal 9
- through grounds E9, E15 and E24.

HEADLAMP (FOR CANADA) - DAYTIME LIGHT SYSTEM -

< SERVICE INFORMATION >

With power and ground supplied, the high beam headlamps illuminate.

BATTERY SAVER CONTROL

When the combination switch (lighting switch) is in the 2ND position (ON), and the ignition switch is turned from ON or ACC to OFF, the battery saver control feature is activated.

Under this condition, the headlamps remain illuminated for 5 minutes unless the combination switch (lighting switch) position is changed. If the combination switch (lighting switch) position is changed, then the headlamps are turned off.

AUTO LIGHT OPERATION (IF EQUIPPED)

For auto light operation, refer to [LT-35. "System Description"](#).

DAYTIME LIGHT OPERATION

With the engine running, the lighting switch in the OFF or 1ST position and parking brake released, power is supplied

- through daytime light control unit terminal 6
- to front combination lamp LH terminal 3
- through front combination lamp LH terminal 4
- to daytime light control unit terminal 7, and
- through daytime light control unit terminal 8
- to front combination lamp RH terminal 3.

Ground is supplied

- to front combination lamp RH terminal 4
- through grounds E9, E15 and E24.

Because the high beam headlamps are now wired in series, they operate at half illumination.

CAN Communication System Description

INFOID:000000001719056

Refer to [LAN-3. "CAN Communication System"](#).

A
B
C
D
E
F
G
H
I
J
L
M
N
O
P

LT

HEADLAMP (FOR CANADA) - DAYTIME LIGHT SYSTEM -

< SERVICE INFORMATION >

Schematic

INFOID:000000001719057

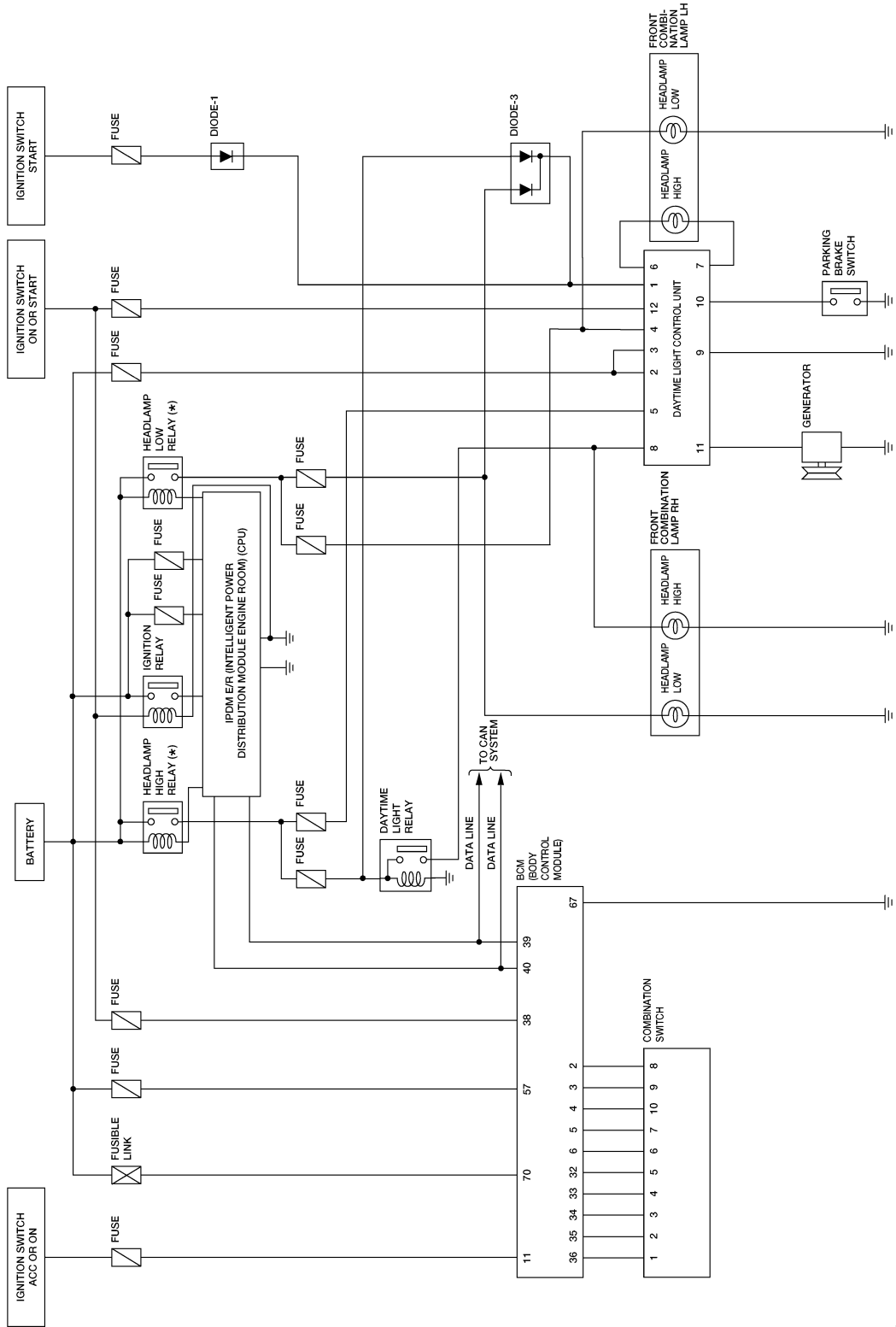

*: THIS RELAY IS BUILT INTO THE IPDM E/R (INTELLIGENT POWER DISTRIBUTION MODULE ENGINE ROOM).

WKWA4684E

HEADLAMP (FOR CANADA) - DAYTIME LIGHT SYSTEM -

< SERVICE INFORMATION >

LT-DTRL-03

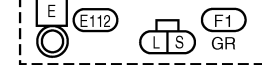
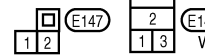
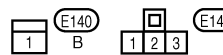
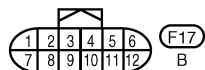
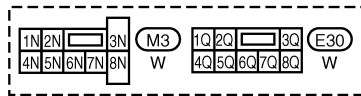
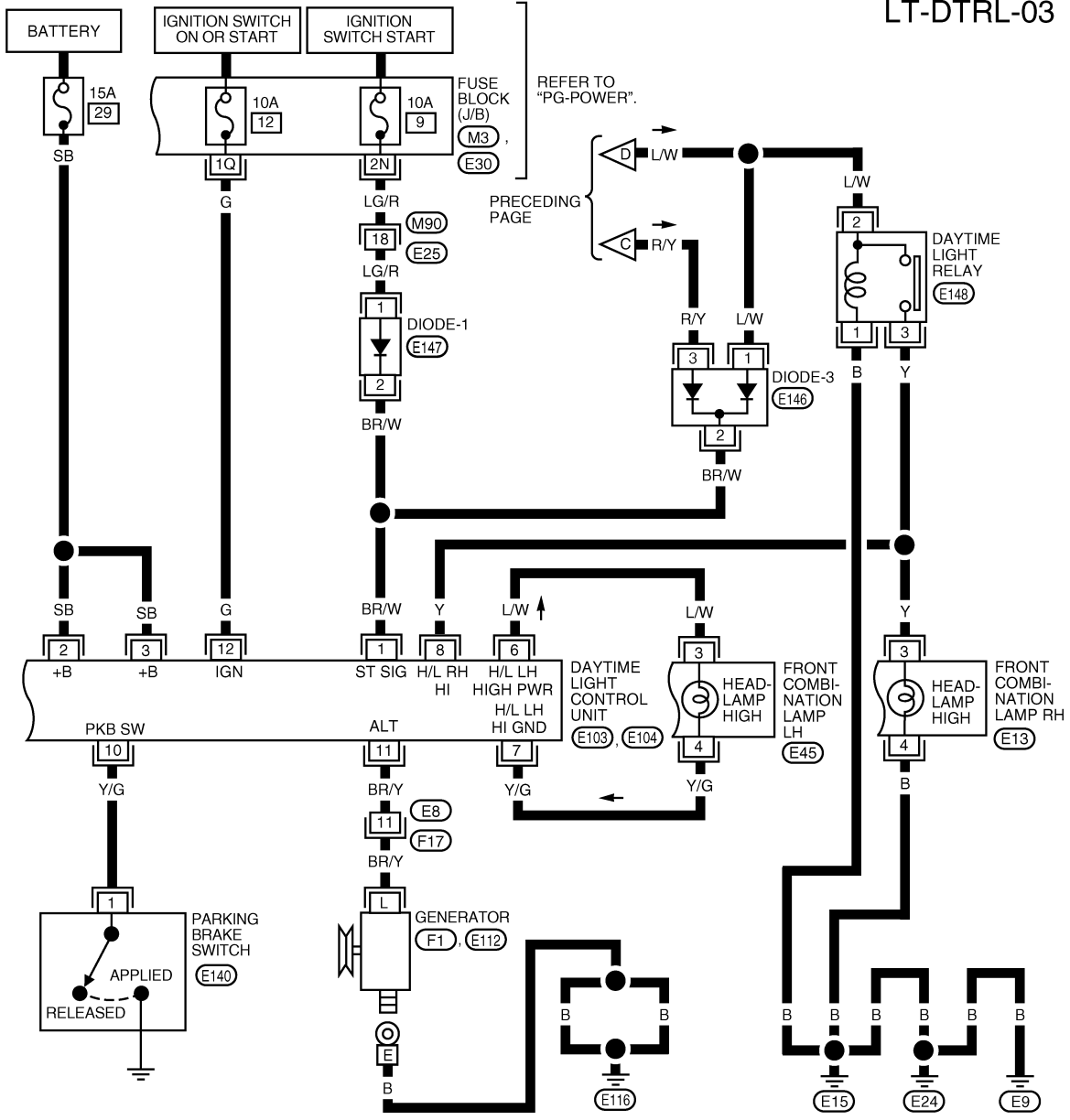

WKWA4687E

A
B
C
D
E
F
G
H
I
J
K
L
M
N
O
P

LT

HEADLAMP (FOR CANADA) - DAYTIME LIGHT SYSTEM -

< SERVICE INFORMATION >

Trouble Diagnosis

INFOID:000000001719059

DAYTIME LIGHT CONTROL UNIT HARNESS CONNECTOR TERMINAL LAYOUT

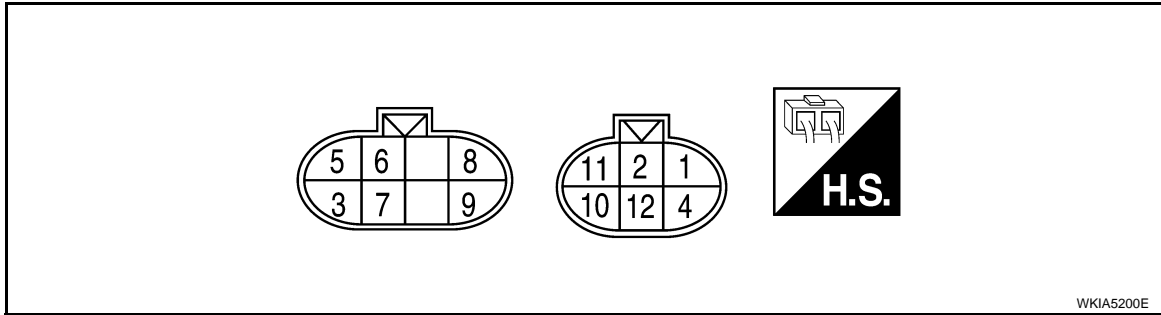

DAYTIME LIGHT CONTROL UNIT INSPECTION TABLE

Terminal No.	Wire color	Item	Condition	Voltage (Approx.)
1	BR/W	Ignition switch start signal	Ignition switch in START position	Battery voltage
			All other conditions	0V
2	SB	Battery	Ignition switch in all positions	Battery voltage
3	SB	Battery	Ignition switch in all positions	Battery voltage
4	L	Lighting switch headlamp LH low beam output	Lighting switch in the headlamp ON (2ND) position and low beam (B) position	Battery voltage
			All other conditions	0V
5	G	Lighting switch headlamp LH high beam output	Lighting switch in the flash-to-pass (C) position or headlamp ON (2ND) position and high beam (A) position	Battery voltage
			All other conditions	0V
6	L/W	Headlamp LH high beam	Lighting switch in the flash-to-pass (C) position or headlamp ON (2ND) position and high beam (A) position	Battery voltage
			With parking brake released, engine running and lighting switch in OFF or parking and tail lamp ON (1ST) positions CAUTION: Block wheels and ensure selector lever is in P or N position.	Battery voltage
			All other conditions	0V
7	Y/G	Headlamp LH (high) control	Lighting switch in the flash-to-pass (C) position or headlamp ON (2ND) position and high beam (A) position and high beam position	0V
			With parking brake released, engine running and lighting switch in OFF or parking and tail lamp ON (1ST) positions CAUTION: Block wheels and ensure selector lever is in P or N position.	Battery voltage
			All other conditions	0V
8	Y	Lighting switch headlamp RH high beam output	Lighting switch in the flash-to-pass (C) position or headlamp ON (2ND) position and high beam (A) position	Battery voltage
			With parking brake released, engine running and lighting switch in OFF or parking and tail lamp ON (1ST) positions CAUTION: Block wheels and ensure selector lever is in P or N position.	6V
			All other conditions	0V

HEADLAMP (FOR CANADA) - DAYTIME LIGHT SYSTEM -

< SERVICE INFORMATION >

9	B	Ground	—	—
10	Y/G	Parking brake switch	Parking brake released	Battery voltage
			Parking brake set	0V
11	BR/Y	Generator (L terminal)	When engine is running	Battery voltage
			All other conditions	0V
12	G	Ignition switch on signal	Ignition switch OFF, ACC positions	0V
			Ignition switch ON, START positions	Battery voltage

Aiming Adjustment

INFOID:000000001719060

Refer to [LT-21. "Aiming Adjustment"](#).

Bulb Replacement

INFOID:000000001719061

Refer to [LT-22. "Bulb Replacement"](#).

Removal and Installation

INFOID:000000001719062

FRONT COMBINATION LAMP

Refer to [LT-23. "Removal and Installation"](#).

DAYTIME LIGHT CONTROL UNIT

Removal

1. Remove the daytime light control unit bolt.
2. Disconnect connectors.
3. Remove daytime light control unit.

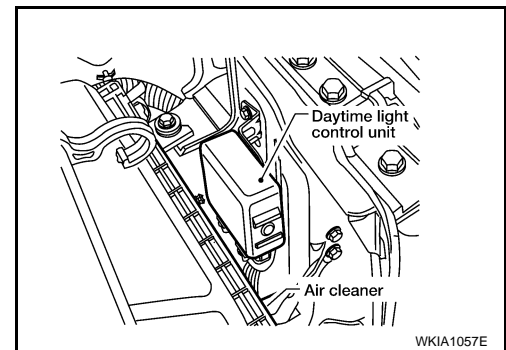

Installation

Installation is in the reverse order of removal.

DAYTIME LIGHT RELAY

Removal

NOTE:

The daytime light relay is taped to the main wiring harness near the lower dash side finisher RH.

1. Remove the glove box assembly. Refer to [IP-14. "Glove Box"](#).
2. Carefully remove the tape holding the daytime light relay to the main harness.
3. Disconnect the connector.
4. Remove daytime light relay.

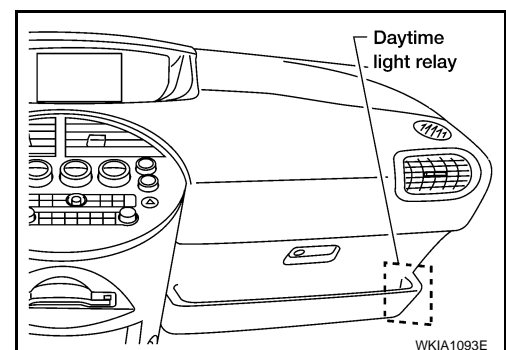

INSTALLATION

Installation is in the reverse order of removal.

HEADLAMP (FOR CANADA) - DAYTIME LIGHT SYSTEM -

< SERVICE INFORMATION >

Disassembly and Assembly

INFOID:000000001719063

FRONT COMBINATION LAMP

Refer to [LT-24, "Disassembly and Assembly"](#).

AUTO LIGHT SYSTEM

< SERVICE INFORMATION >

AUTO LIGHT SYSTEM

Component Parts and Harness Connector Location

INFOID:000000001719064

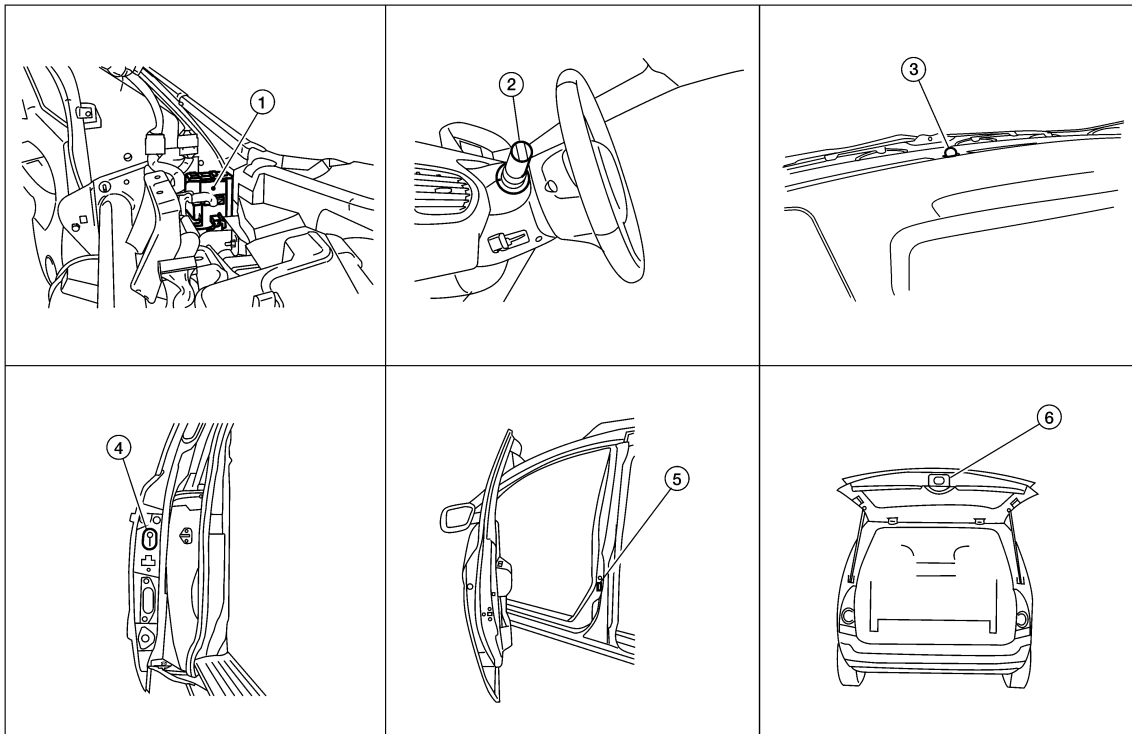

WKIA5261E

- | | | |
|-----------------------------------------------------------|-------------------------------------|--------------------------------------------|
| 1. BCM M18, M19, M20 (view with instrument panel removed) | 2. Combination switch M28 | 3. Optical sensor M16 |
| 4. Sliding door switch LH B46, RH B135 | 5. Front door switch LH B8, RH B108 | 6. Back door latch (door ajar switch) D511 |

System Description

INFOID:000000001719065

Automatically turns on/off the parking lamps and the headlamps in accordance with ambient light. Timing for when the lamps turn on/off can be selected using eight modes. Mode selections are accessed through the vehicle electronic settings menu of the color display (refer to owners manual) or with CONSULT-III.

OUTLINE

The auto light control system uses an optical sensor that detects outside brightness.

When the lighting switch is in "AUTO" position, it automatically turns on/off the parking lamps and the headlamps in accordance with the ambient light. Sensitivity can be adjusted using four modes. For the details of the setting, refer to [LT-41. "CONSULT-III Function \(BCM\)"](#).

Optical sensor ground is supplied

- to optical sensor terminal 3
- through BCM (body control module) terminal 18.

When ignition switch is turned to "ON" position and when outside brightness is darker than prescribed level, input is supplied

- to BCM terminal 58
- from optical sensor terminal 4.

The headlamps will then illuminate. For a description of headlamp operation, refer to [LT-5. "System Description"](#).

COMBINATION SWITCH READING FUNCTION

Refer to [BCS-3. "System Description"](#).

AUTO LIGHT SYSTEM

< SERVICE INFORMATION >

EXTERIOR LAMP BATTERY SAVER CONTROL

When the combination switch (lighting switch) is in the AUTO position, the ignition switch is turned from ON or ACC to OFF, and one of the front doors is opened, the battery saver control feature is activated. Under this condition, the headlamps remain illuminated for 5 minutes, then the headlamp are turned off. Exterior lamp battery saver control mode can be changed by the function setting of CONSULT-III.

DELAY TIMER FUNCTION

When the ignition switch is ON and auto light switch is ON, the BCM turns on/off the headlamps. In delay timer function, ignition is OFF, auto light sensor power source is OFF and the headlamps are not turned on/off by the BCM. On condition that:

- when the state of ignition switch ON or ACC is ON and output judgment by auto light function is headlamp ON changes to ignition switch and ACC are OFF and any door switch is ON, output judgment by BCM should be headlamp ON for 5 minutes by timer. After time out, output judgment by BCM should be headlamp OFF.
- when the state of any door switch is turned to ON from OFF while 45 second or 5 minute timer is counting, timer stops, and restarts counting for 5 minutes, then BCM judges output as headlamp ON. After time out, BCM judges output as headlamp OFF.
- when the state of front door switch LH, front door switch RH, rear door switch LH, rear door switch RH or back door latch (door ajar switch) is ON turns to all door switches are OFF while 45 second or 5 minute timer is counting, timer stops, and restarts counting for 45 seconds, then BCM judges output as headlamp ON. After timer out, BCM judges output as headlamp OFF.
- when the state is ignition switch ON or ACC is ON or auto light switch OFF while timer is counting, timer stops counting and BCM turns on/off lamps according to headlamp function, front fog lamp function, auto light function and headlamp battery save function.

Delay timer control mode can be changed by the function setting of CONSULT-III or with the display (with color display).

CAN Communication System Description

INFOID:000000001719066

Refer to [LAN-3, "CAN Communication System"](#).

Major Component and Functions

INFOID:000000001719067

Components	Functions
BCM	<ul style="list-style-type: none">• Turns on/off circuits of tail light and headlamp according to signals from light sensor, lighting switch (AUTO), front door switch LH, front door switch RH, sliding door switch LH and RH, back door latch (door ajar switch), and ignition switch (ON, OFF).
Optical sensor	<ul style="list-style-type: none">• Converts ambient light (lux) to voltage and sends it to BCM. (Detects lightness of 50 to 1,300 lux)

AUTO LIGHT SYSTEM

< SERVICE INFORMATION >

Schematic

INFOID:000000001719068

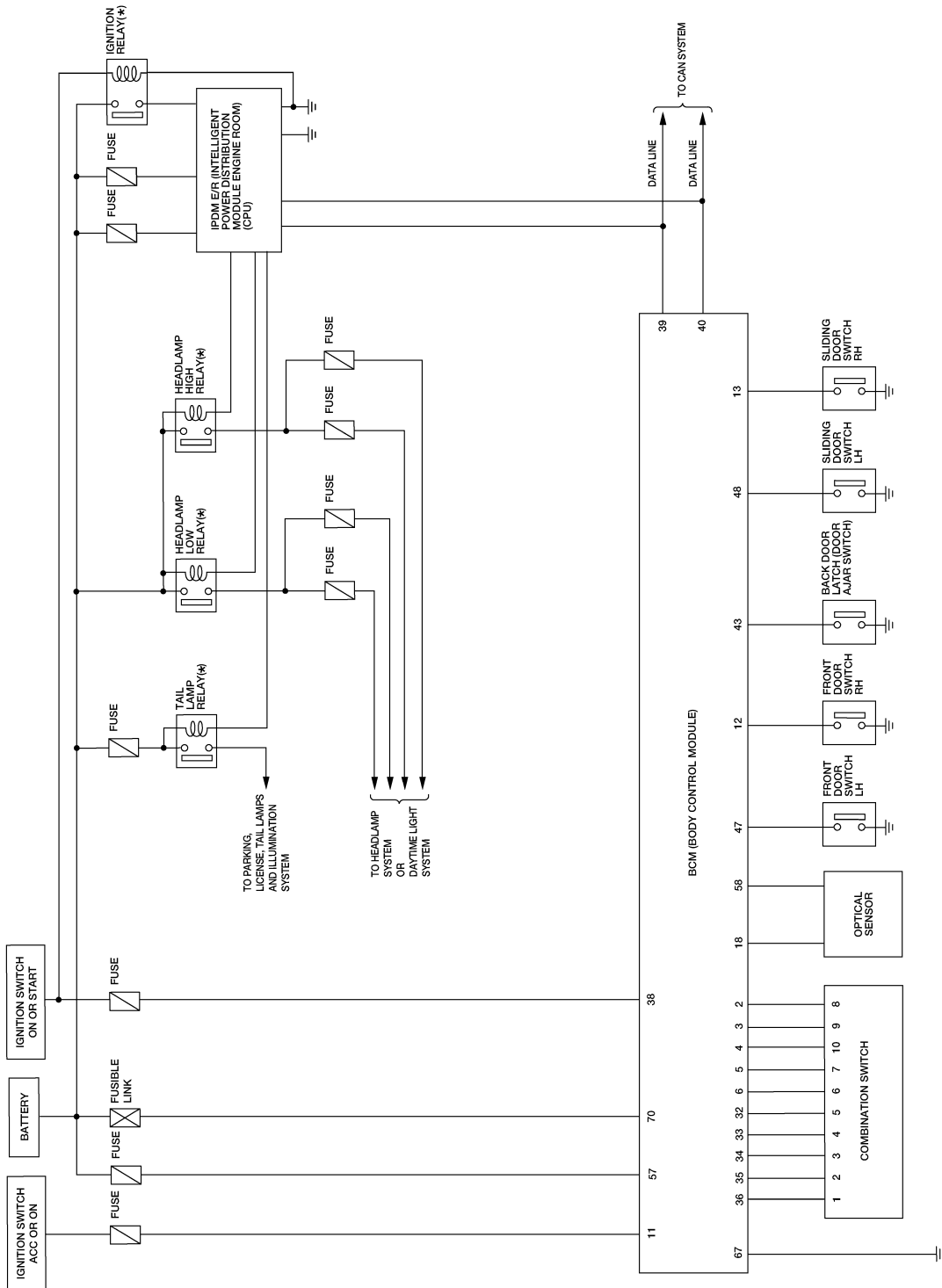

*: THIS RELAY IS BUILT INTO THE IPDM E/R (INTELLIGENT POWER DISTRIBUTION MODULE ENGINE ROOM).

WKWA4688E

A
B
C
D
E
F
G
H
I
J
K
L
M
N
O
P

LT

AUTO LIGHT SYSTEM

< SERVICE INFORMATION >

Wiring Diagram - AUTO/L -

INFOID:000000001719069

LT-AUTO/L-01

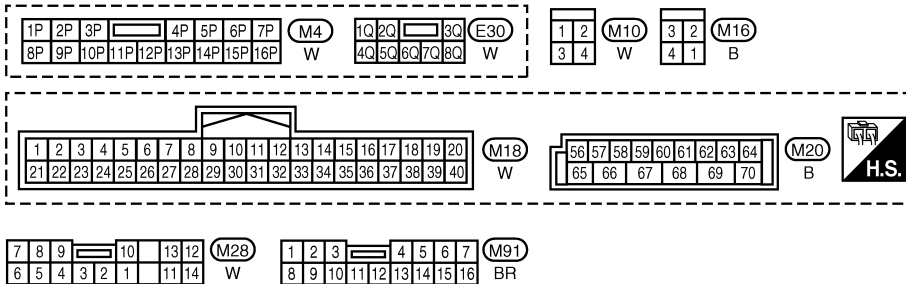
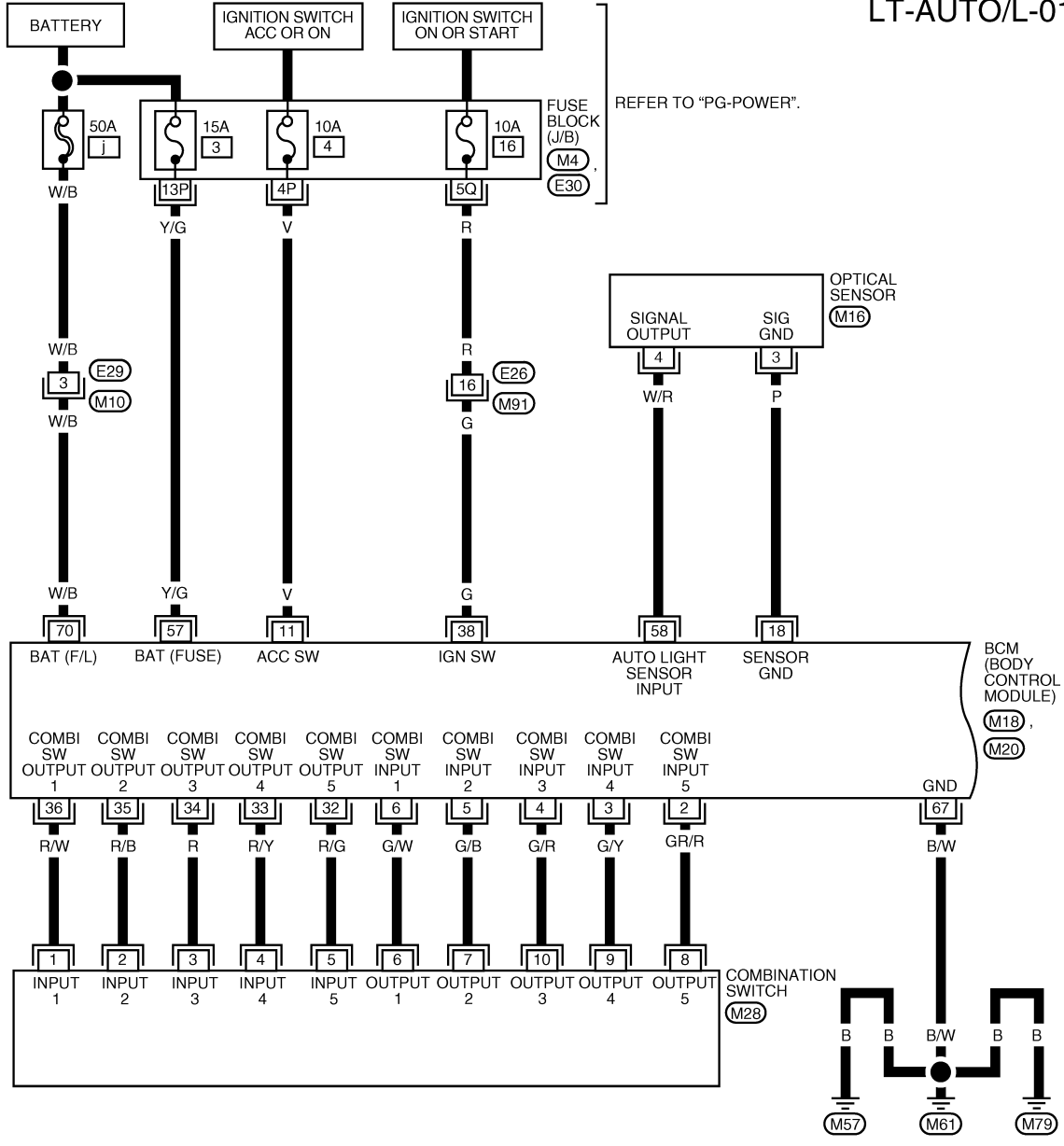

WKWA4689E

AUTO LIGHT SYSTEM

< SERVICE INFORMATION >

LT-AUTO/L-03

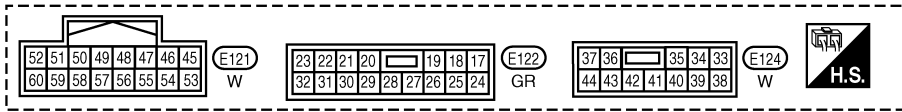
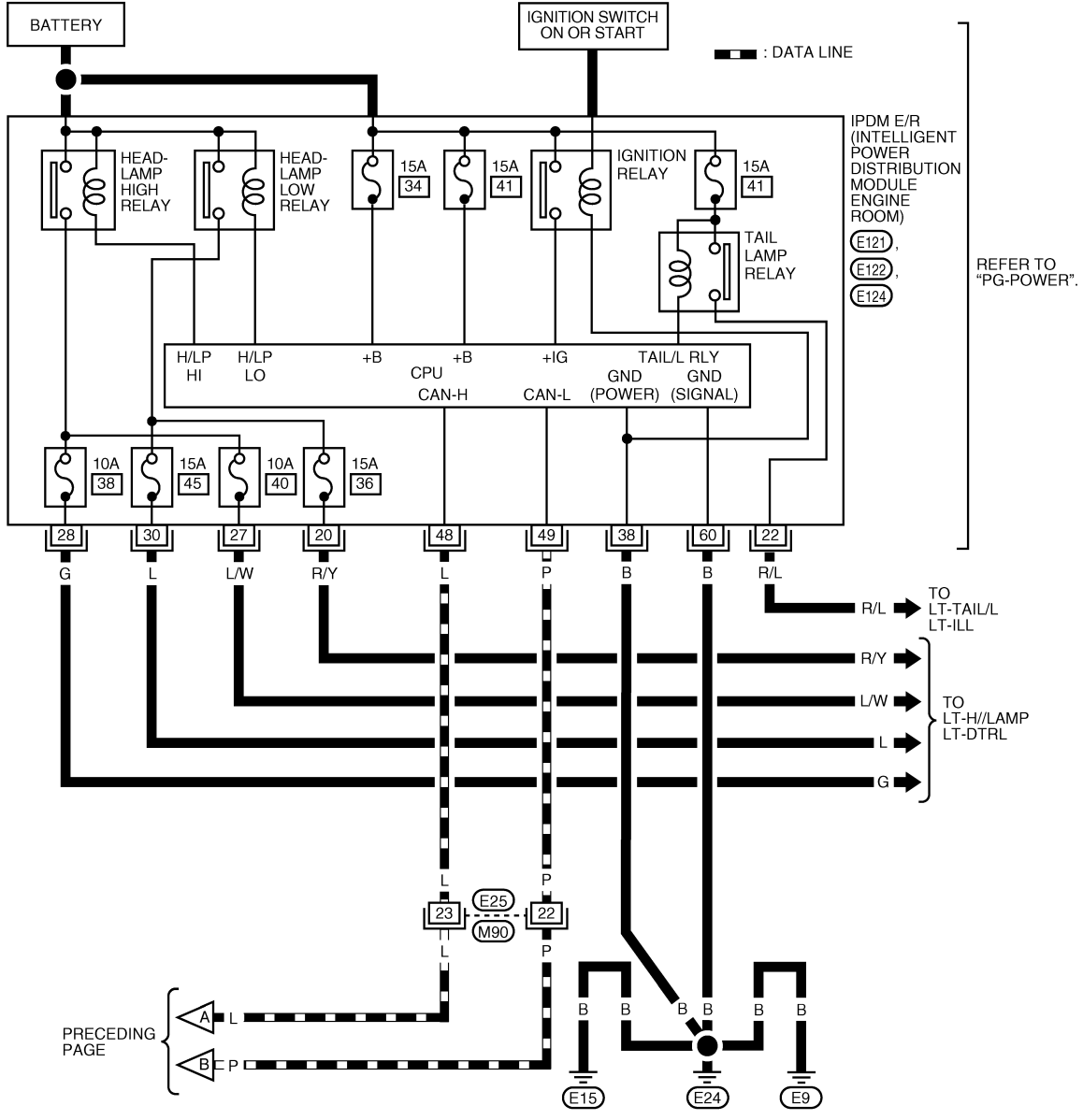

WKWA4691E

Terminal and Reference Value for BCM

INFOID:000000001719070

Refer to [BCS-11](#). "Terminal and Reference Value for BCM".

Terminal and Reference Value for IPDM E/R

INFOID:000000001719071

Refer to [PG-24](#). "Terminal and Reference Value for IPDM E/R".

AUTO LIGHT SYSTEM

< SERVICE INFORMATION >

How to Proceed with Trouble Diagnosis

INFOID:000000001719072

1. Confirm the symptom or customer complaint.
2. Understand operation description and function description. Refer to [LT-35, "System Description"](#).
3. Carry out the Preliminary Check. Refer to [LT-41, "Preliminary Check"](#).
4. Check symptom and repair or replace the cause of malfunction. Refer to [LT-44, "Trouble Diagnosis Chart by Symptom"](#).
5. Does the auto light system operate normally? If YES: GO TO 6. If NO: GO TO 4.
6. Inspection End.

Preliminary Check

INFOID:000000001719073

SETTING CHANGE FUNCTIONS

- Sensitivity of auto light system can be adjusted using CONSULT-III. Refer to [LT-41, "CONSULT-III Function \(BCM\)"](#).

CHECK BCM CONFIGURATION

1. CHECK BCM CONFIGURATION

Confirm BCM configuration for "AUTO LIGHT" is set to "WITH". Refer to [BCS-17, "Configuration"](#).

OK or NG

- OK >> Continue preliminary check. Refer to "CHECK POWER SUPPLY AND GROUND CIRCUIT".
- NG >> Change BCM configuration for "AUTO LIGHT" to "WITH". Refer to [BCS-17, "Configuration"](#).

CHECK POWER SUPPLY AND GROUND CIRCUIT

Refer to [BCS-15, "BCM Power Supply and Ground Circuit Inspection"](#).

Refer to [PG-27, "IPDM E/R Power/Ground Circuit Inspection"](#).

CONSULT-III Function (BCM)

INFOID:000000001719074

CONSULT-III can display each diagnostic item using the diagnostic test modes shown following.

BCM diagnostic test item	Diagnostic mode	Description
Inspection by part	WORK SUPPORT	Supports inspections and adjustments. Commands are transmitted to the BCM for setting the status suitable for required operation, input/output signals are received from the BCM and received data is displayed.
	DATA MONITOR	Displays BCM input/output data in real time.
	ACTIVE TEST	Operation of electrical loads can be checked by sending drive signal to them.
	SELF-DIAG RESULTS	Displays BCM self-diagnosis results.
	CAN DIAG SUPPORT MNTR	The result of transmit/receive diagnosis of CAN communication can be read.
	ECU PART NUMBER	BCM part number can be read.
	CONFIGURATION	Performs BCM configuration read/write functions.

WORK SUPPORT

Operation Procedure

1. Touch "HEAD LAMP" on "SELECT TEST ITEM" screen.
2. Touch "WORK SUPPORT" on "SELECT DIAG MODE" screen.
3. Touch "CUSTOM A/LIGHT SETTING" or "ILL DELAY SET" on "SELECT WORK ITEM" screen.
4. Touch "START".
5. Touch "MODE 1-4" of setting to be changed (CUSTOM A/LIGHT SETTING). Touch "MODE1-8" of setting to be changed (ILL DELAY SET).
6. Touch "CHANGE SETT".
7. The setting will be changed and "CUSTOMIZING COMPLETED" will be displayed.
8. Touch "END".

AUTO LIGHT SYSTEM

< SERVICE INFORMATION >

Work Support Setting Item

- Sensitivity of auto light can be selected and set from four modes.

Work item	Description
CUSTOM A/LIGHT SETTING	Auto light sensitivity can be changed in this mode. Sensitivity can be adjusted in four modes. • MODE 1 (Normal)/ MODE 2 (Sensitive)/MODE 3 (Desensitized)/MODE 4 (Insensitive)
ILL DELAY SET	Auto light delay off timer period can be changed in this mode. Selects auto light delay off timer period among eight modes. • MODE 1 (45 sec.)/MODE 2 (OFF)/MODE 3 (30 sec.)/MODE 4 (60 sec.)/MODE 5 (90 sec.)/MODE 6 (120 sec.)/MODE 7 (150 sec.)/MODE 8 (180 sec.)

DATA MONITOR

Operation Procedure

1. Touch "HEAD LAMP" on "SELECT TEST ITEM" screen.
2. Touch "DATA MONITOR" on "SELECT DIAG MODE" screen.
3. Touch either "ALL SIGNALS" or "SELECTION FROM MENU" on the "SELECT MONITOR ITEM" screen.

ALL SIGNALS	Monitors all the signals.
SELECTION FROM MENU	Selects and monitors individual signal.

4. Touch "START".
5. When "SELECTION FROM MENU" is selected, touch individual items to be monitored. When "ALL SIGNALS" is selected, all the items will be monitored.
6. Touch "RECORD" while monitoring, then the status of the monitored item can be recorded. To stop recording, touch "STOP".

Display Item List

Monitor item	Contents
IGN ON SW "ON/OFF"	Displays "IGN position (ON)/OFF, ACC position (OFF)" judged from the ignition switch signal.
ACC ON SW "ON/OFF"	Displays "ACC (ON)/OFF, Ignition OFF (OFF)" status judged from ignition switch signal.
HI BEAM SW "ON/OFF"	Displays status (high beam switch: ON/Others: OFF) of high beam switch judged from lighting switch signal.
HEAD LAMP SW 1 "ON/OFF"	Displays status (headlamp switch 1: ON/Others: OFF) of headlamp switch 2 judged from lighting switch signal.
HEAD LAMP SW 2 "ON/OFF"	Displays status (headlamp switch 2: ON/Others: OFF) of headlamp switch 2 judged from lighting switch signal.
LIGHT SW 1ST "ON/OFF"	Displays status (lighting switch 1st position: ON/Others: OFF) of lighting switch judged from lighting switch signal.
AUTO LIGHT SW "ON/OFF"	Displays status of the lighting switch as judged from the lighting switch signal. (AUTO position: ON/Other than AUTO position: OFF)
PASSING SW "ON/OFF"	Displays status (flash-to-pass switch: ON/Others: OFF) of flash-to-pass switch judged from lighting switch signal.
FR FOG SW "ON/OFF"	Displays status (front fog lamp switch: ON/Others: OFF) of front fog lamp switch judged from lighting switch signal.
DOOR SW-DR "ON/OFF"	Displays status of the front door LH as judged from the front door switch LH signal. (Door is open: ON/Door is closed: OFF)
DOOR SW-AS "ON/OFF"	Displays status of the front door RH as judged from the front door switch RH signal. (Door is open: ON/Door is closed: OFF)
DOOR SW-RR "ON/OFF"	Displays status of the sliding door as judged from the sliding door switch (RH) signal. (Door is open: ON/Door is closed: OFF)
DOOR SW-RL "ON/OFF"	Displays status of the sliding door as judged from the sliding door switch (LH) signal. (Door is open: ON/Door is closed: OFF)
BACK DOOR SW "ON/OFF"	Displays status of the back door as judged from the back door switch signal. (Door is open: ON/Door is closed: OFF)

AUTO LIGHT SYSTEM

< SERVICE INFORMATION >

Monitor item	Contents
TURN SIGNAL R "ON/OFF"	Displays status (Turn right: ON/Others: OFF) as judged from lighting switch signal.
TURN SIGNAL L "ON/OFF"	Displays status (Turn left: ON/Others: OFF) as judged from lighting switch signal.
CARGO LAMP SW "ON/OFF"	Displays status of cargo lamp.
OPTICAL SENSOR [0 - 5V]	Displays "ambient light (close to 5V when dark/close to 0V when light)" judged from optical sensor signal.

ACTIVE TEST

Operation Procedure

1. Touch "HEAD LAMP" on "SELECT TEST ITEM" screen.
2. Touch "ACTIVE TEST" on "SELECT DIAG MODE" screen.
3. Touch item to be tested and check operation of the selected item.
4. During the operation check, touching "BACK" deactivates the operation.

Display Item List

Test item	Description
TAIL LAMP	Allows tail lamp relay to operate by switching ON-OFF.
HEAD LAMP	Allows headlamp relay (HI, LO) to operate by switching ON-OFF.
FR FOG LAMP	Allows fog lamp relay to operate by switching ON-OFF.
CARGO LAMP	Allows cargo lamp to operate by switching ON-OFF.
CORNERING LAMP	Allows cornering lamp relay (RH, LH) to operate by switching ON-OFF.

CONSULT-III Function (IPDM E/R)

INFOID:000000001719075

CONSULT-III can display each diagnostic item using the diagnostic test modes shown following.

IPDM E/R diagnostic Mode	Description
SELF-DIAG RESULTS	Displays IPDM E/R self-diagnosis results.
DATA MONITOR	Displays IPDM E/R input/output data in real time.
CAN DIAG SUPPORT MNTR	The result of transmit/receive diagnosis of CAN communication can be read.
ACTIVE TEST	Operation of electrical loads can be checked by sending drive signal to them.

DATA MONITOR

Operation Procedure

1. Touch "DATA MONITOR" on "SELECT DIAG MODE" screen.
2. Touch "ALL SIGNALS", "MAIN SIGNALS" or "SELECTION FROM MENU" on the "SELECT MONITOR ITEM" screen.

ALL SIGNALS	All items will be monitored.
MAIN SIGNALS	Monitor the predetermined item.
SELECTION FROM MENU	Select any item for monitoring.

3. Touch "START".
4. Touch the required monitoring item on "SELECTION FROM MENU". In "ALL SIGNALS", all items are monitored. In "MAIN SIGNALS", predetermined items are monitored.
5. Touch "RECORD" while monitoring to record the status of the item being monitored. To stop recording, touch "STOP".

All Signals, Main Signals, Selection From Menu

AUTO LIGHT SYSTEM

< SERVICE INFORMATION >

Item name	CONSULT-III screen display	Display or unit	Monitor item selection			Description
			ALL SIGNALS	MAIN SIGNALS	SELECTION FROM MENU	
Parking, license plate and tail lamps request	TAIL&CLR REQ	ON/OFF	×	×	×	Signal status input from BCM
Headlamp low beam request	HL LO REQ	ON/OFF	×	×	×	Signal status input from BCM
Headlamp high beam request	HL HI REQ	ON/OFF	×	×	×	Signal status input from BCM
Cornering lamp	CRNRNG LMP REQ	ON/OFF	×	-	×	Signal status input from BCM
Front fog lamps request	FR FOG REQ	ON/OFF	×	×	×	Signal status input from BCM

NOTE:

Perform monitoring of IPDM E/R data with the ignition switch ON. When the ignition switch is at ACC, the display may not be correct.

ACTIVE TEST

Operation Procedure

1. Touch "ACTIVE TEST" on "SELECT DIAG MODE" screen.
2. Touch item to be tested, and check operation.
3. Touch "START".
4. Touch "STOP" while testing to stop the operation.

Test item	CONSULT-III screen display	Description
Tail lamp relay output	TAIL LAMP	Allows tail lamp relay to operate by switching operation ON-OFF at your option.
Headlamp relay (HI, LO) output	LAMPS	Allows headlamp relay (HI, LO) to operate by switching operation (OFF, HI, LO) at your option (Headlamp high beam repeats ON-OFF every 1 second).
Front fog lamp relay output		Allows fog lamp relay to operate by switching operation ON-OFF at your option.
Cornering lamp relay (RH, LH) output	CORNERING LAMP	Allows cornering lamp relay (RH, LH) to operate by switching operation ON-OFF at your option.

Trouble Diagnosis Chart by Symptom

INFOID:000000001719076

Trouble phenomenon	Malfunction system and reference
<ul style="list-style-type: none"> • Parking lamps and headlamps will not illuminate when outside of the vehicle becomes dark. (Lighting switch 1st position and 2nd position operate normally.) • Parking lamps and headlamp will not go out when outside of the vehicle becomes light. (Lighting switch 1st position and 2nd position operate normally.) • Headlamps go out when outside of the vehicle becomes light, but parking lamps stay on. 	<ul style="list-style-type: none"> • Refer to LT-41, "CONSULT-III Function (BCM)". • Refer to LT-45, "Lighting Switch Inspection". • Refer to LT-45, "Optical Sensor System Inspection". <p>If above systems are normal, replace BCM. Refer to BCS-18, "Removal and Installation of BCM".</p>
<p>Parking lamps illuminate when outside of the vehicle becomes dark, but headlamps stay off. (Lighting switch 1st position and 2nd position operate normally.)</p>	<ul style="list-style-type: none"> • Refer to LT-41, "CONSULT-III Function (BCM)". • Refer to LT-45, "Optical Sensor System Inspection". <p>If above systems are normal, replace BCM. Refer to BCS-18, "Removal and Installation of BCM".</p>
<p>Auto light adjustment system will not operate. (Lighting switch AUTO, 1st position and 2nd position operate normally.)</p>	<ul style="list-style-type: none"> • Refer to LT-45, "Optical Sensor System Inspection". <p>If above systems is normal, replace BCM. Refer to BCS-18, "Removal and Installation of BCM".</p>

AUTO LIGHT SYSTEM

< SERVICE INFORMATION >

Trouble phenomenon	Malfunction system and reference
Auto light adjustment system will not operate.	<ul style="list-style-type: none"> CAN communication line to BCM inspection. Refer to BCS-17, "CAN Communication Inspection Using CONSULT-III (Self-Diagnosis)".
Shut off delay feature will not operate.	<ul style="list-style-type: none"> CAN communication line inspection between BCM and combination meter. Refer to BCS-17, "CAN Communication Inspection Using CONSULT-III (Self-Diagnosis)". Refer to BL-35, "Door Switch Check (Without Automatic Back Door System)". <p>If above systems is normal, replace BCM. Refer to BCS-18, "Removal and Installation of BCM".</p>

Lighting Switch Inspection

INFOID:000000001719077

1. CHECK LIGHTING SWITCH INPUT SIGNAL

 With CONSULT-III

Select "BCM" on CONSULT-III. With "HEAD LAMP" data monitor, make sure "AUTO LIGHT SW" turns ON-OFF linked with operation of lighting switch.

When lighting switch is in AUTO position : AUTO LIGHT SW ON

 Without CONSULT-III

Refer to [LT-81, "Combination Switch Inspection"](#).

OK or NG

OK >> Inspection End.

NG >> Check lighting switch. Refer to [LT-81, "Combination Switch Inspection"](#).

Optical Sensor System Inspection

INFOID:000000001719078

1. CHECK OPTICAL SENSOR INPUT SIGNAL

 With CONSULT-III

Select "BCM" on CONSULT-III. With "OPTICAL SENSOR" data monitor, check difference in the voltage when the optical sensor is illuminated and not illuminated.

**Illuminated
OPTICAL SENSOR : 3.1V or more
Not illuminated
OPTICAL SENSOR : 0.6V or less**

CAUTION:

Optical sensor must be completely subjected to work lamp light. If the optical sensor is insufficiently illuminated, the measured value may not satisfy the standard.

 Without CONSULT-III

GO TO 2.

OK or NG

OK >> Inspection End.

NG >> GO TO 2.

2. CHECK OPTICAL SENSOR SIGNAL GROUND CIRCUIT

AUTO LIGHT SYSTEM

< SERVICE INFORMATION >

1. Turn ignition switch OFF.
2. Disconnect BCM connector and optical sensor connector.
3. Check continuity (open circuit) between BCM harness connector M18 terminal 18 and optical sensor harness connector M16 terminal 3.

18 - 3 : Continuity should exist.

4. Check continuity (short circuit) between BCM harness connector M18 terminal 18 and ground.

18 - Ground : Continuity should not exist.

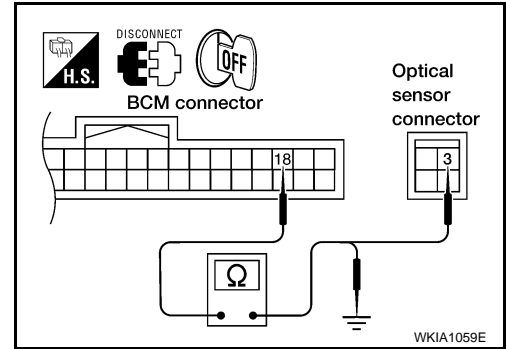

OK or NG

OK >> GO TO 3.

NG >> Repair harness or connector.

3. CHECK OPTICAL SENSOR SIGNAL CIRCUIT

1. Check continuity (open circuit) between BCM connector M20 (A) terminal 58 and optical sensor connector M16 (B) terminal 4.

58 - 4 : Continuity should exist.

2. Check continuity (short circuit) between BCM harness connector M20 terminal 58 and ground.

58 - Ground : Continuity should not exist.

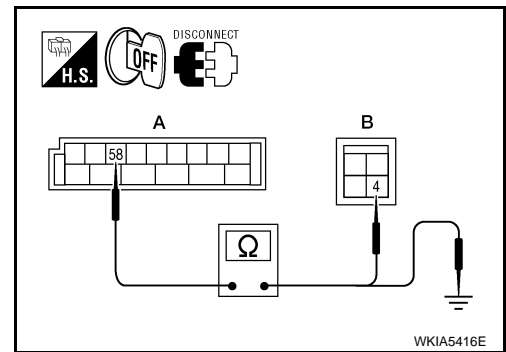

OK or NG

OK >> Replace optical sensor. Refer to [LT-46, "Removal and Installation"](#). Recheck sensor output with CONSULT-III.

If NG, replace BCM. Refer to [BCS-18, "Removal and Installation of BCM"](#).

NG >> Repair harness or connector.

Removal and Installation

INFOID:000000001719079

OPTICAL SENSOR

Removal

1. Remove defrost grille. Refer to [IP-10, "Instrument Panel"](#).
2. Disconnect the connector.
3. Turn the optical sensor counterclockwise to remove it from defroster grille.

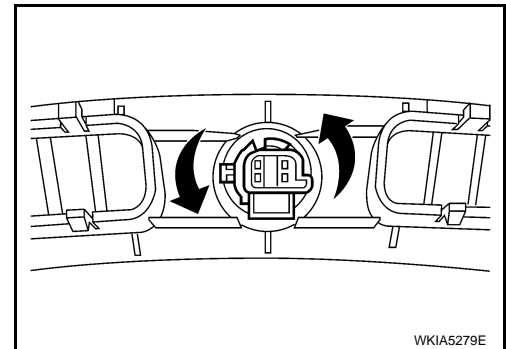

Installation

Installation is in the reverse order of removal.

FRONT FOG LAMP

< SERVICE INFORMATION >

FRONT FOG LAMP

Component Parts and Harness Connector Location

INFOID:000000001719080

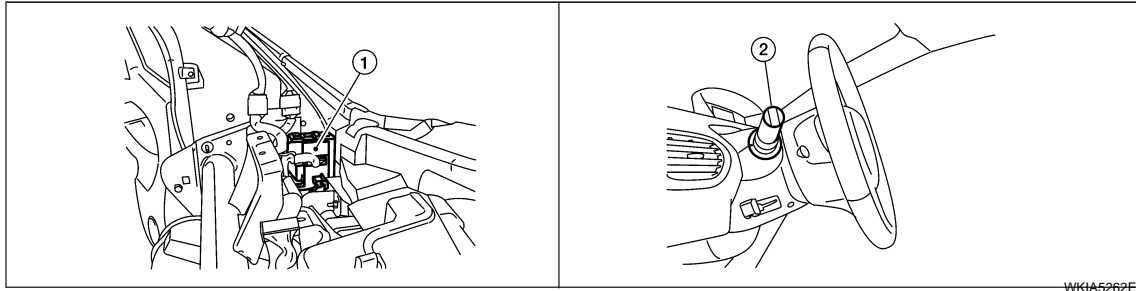

1. BCM M18, M20 (view with instrument panel removed)
2. Combination switch (lighting switch) M28

System Description

INFOID:000000001719081

Control of the fog lamps is dependent upon the position of the combination switch (lighting switch). The lighting switch must be in the 2ND position or AUTO position (LOW beam is ON) for front fog lamp operation. When the lighting switch is placed in the fog lamp position, the BCM (body control module) receives input signal requesting the fog lamps to illuminate. When the headlamps are illuminated, this input signal is communicated to the IPDM E/R (intelligent power distribution module engine room) across the CAN communication lines. The CPU (central processing unit) of the IPDM E/R controls the front fog lamp relay coil. When activated, this relay directs power to the front fog lamps.

OUTLINE

Power is supplied at all times

- to ignition relay, located in the IPDM E/R, and
- through 15A fuse (No. 43, located in the IPDM E/R)
- to front fog lamp relay, located in the IPDM E/R, and
- through 15A fuse (No. 34, located in the IPDM E/R)
- to CPU of the IPDM E/R, and
- through 15A fuse (No. 41, located in the IPDM E/R)
- to CPU of the IPDM E/R, and
- through 50A fusible link (letter j, located in the fuse and fusible link box)
- to BCM terminal 70, and
- through 15A fuse [No. 3, located in the fuse block (J/B)]
- to BCM terminal 57.

When the ignition switch is in ON or START position, power is supplied

- to ignition relay, located in the IPDM E/R, and
- through 10A fuse [No. 16, located in the fuse block (J/B)]
- to BCM terminal 38.

When the ignition switch is in ACC or ON position, power is supplied

- through 10A fuse [No. 4, located in the fuse block (J/B)]
- to BCM terminal 11.

Ground is supplied

- to BCM terminal 67
- through grounds M57, M61 and M79, and
- to IPDM E/R terminals 38 and 60
- through grounds E9, E15 and E24.

FOG LAMP OPERATION

The fog lamp switch is built into the combination switch. The lighting switch must be in the 2ND position or AUTO position (LOW beam is ON) and the fog lamp switch must be ON for fog lamp operation.

With the fog lamp switch in the ON position, the CPU of the IPDM E/R grounds the coil side of the fog lamp relay. The fog lamp relay then directs power

- through IPDM E/R terminal 37
- to front fog lamp LH terminal +, and

FRONT FOG LAMP

< SERVICE INFORMATION >

- through IPDM E/R terminal 36
- to front fog lamp RH terminal +.

Ground is supplied

- to front fog lamp LH and RH terminal –
- through grounds E9, E15 and E24.

With power and ground supplied, the front fog lamps illuminate.

COMBINATION SWITCH READING FUNCTION

Refer to [BCS-3. "System Description"](#).

EXTERIOR LAMP BATTERY SAVER CONTROL

When the combination switch (lighting switch) is in the 2ND position (ON), the fog lamp switch is ON and the ignition switch is turned from ON or ACC to OFF, the battery saver control feature is activated.

Under this condition, the fog lamps (and headlamps) remain illuminated for 5 minutes, then the fog lamps (and headlamps) are turned off.

Exterior lamp battery saver control mode can be changed by the function setting of CONSULT-III.

CAN Communication System Description

INFOID:000000001719082

Refer to [LAN-3. "CAN Communication System"](#).

FRONT FOG LAMP

< SERVICE INFORMATION >

LT-F/FOG-02

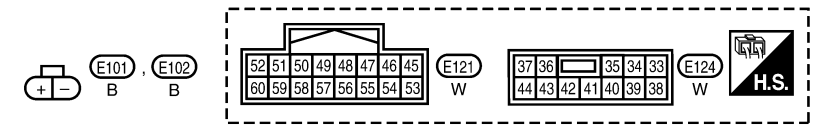
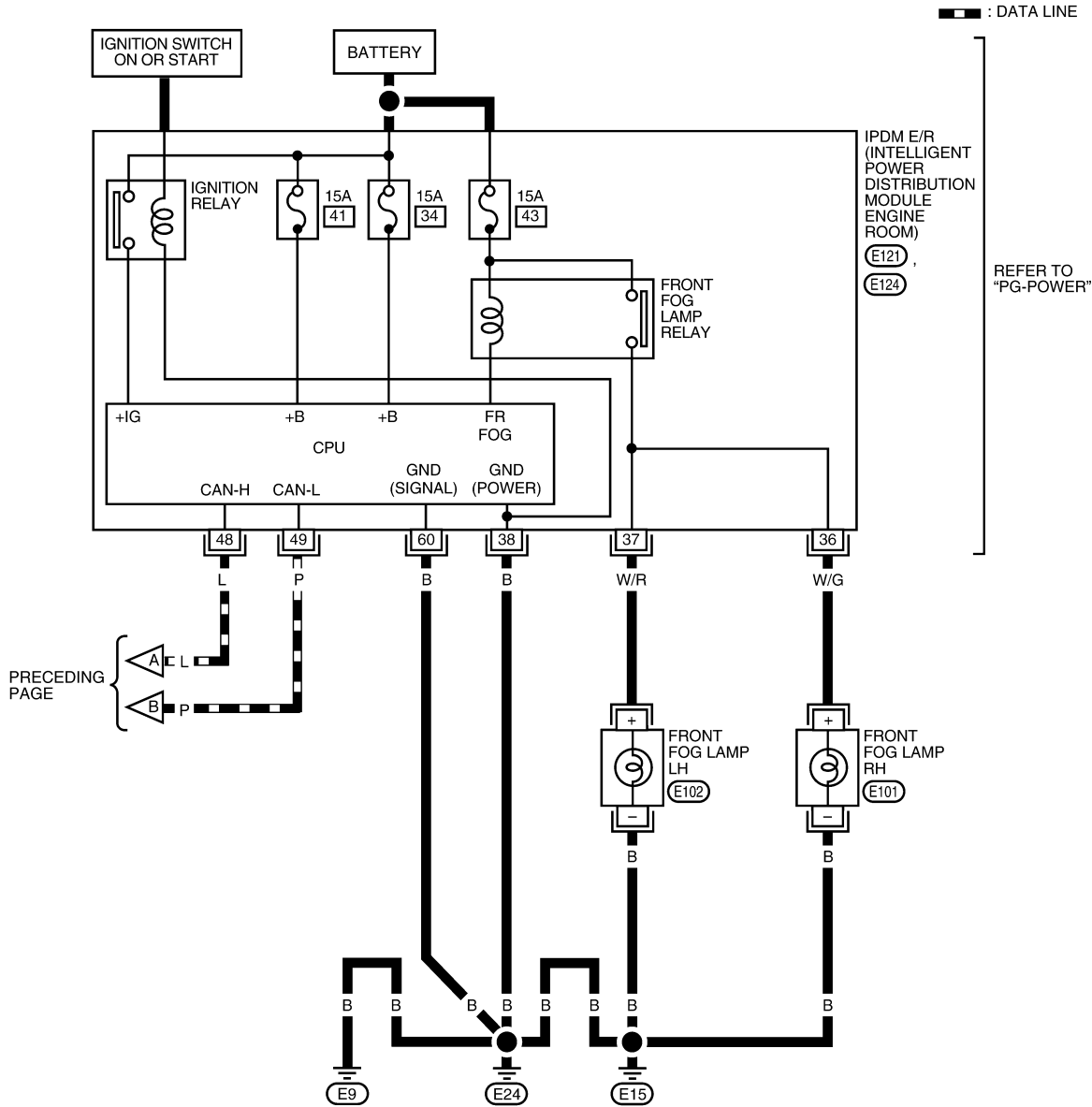

WKWA4693E

Terminal and Reference Value for BCM

INFOID:000000001719084

Refer to [BCS-11](#), "Terminal and Reference Value for BCM".

Terminal and Reference Value for IPDM E/R

INFOID:000000001719085

Refer to [PG-24](#), "Terminal and Reference Value for IPDM E/R".

FRONT FOG LAMP

< SERVICE INFORMATION >

How to Proceed with Trouble Diagnosis

INFOID:000000001719086

1. Confirm the symptom or customer complaint.
2. Understand operation description and function description. Refer to [LT-47, "System Description"](#).
3. Perform the Preliminary Check. Refer to [LT-51, "Preliminary Check"](#).
4. Check symptom and repair or replace the cause of malfunction.
5. Does the front fog lamp operate normally? If YES: GO TO 6. If NO: GO TO 4.
6. Inspection End.

Preliminary Check

INFOID:000000001719087

CHECK BCM CONFIGURATION

1.CHECK BCM CONFIGURATION

Confirm BCM configuration for "FR FOG LAMP" is set to "WITH". Refer to [BCS-17, "Configuration"](#).

OK or NG

- OK >> Continue preliminary check. Refer to "CHECK POWER SUPPLY AND GROUND CIRCUIT".
NG >> Change BCM configuration for "FR FOG LAMP" to "WITH". Refer to [BCS-17, "Configuration"](#).

CHECK POWER SUPPLY AND GROUND CIRCUIT

Refer to [BCS-15, "BCM Power Supply and Ground Circuit Inspection"](#).

Refer to [PG-27, "IPDM E/R Power/Ground Circuit Inspection"](#).

CONSULT-III Functions

INFOID:000000001719088

Refer to [LT-12, "CONSULT-III Function \(BCM\)"](#) in HEADLAMP (FOR USA).

Refer to [LT-14, "CONSULT-III Function \(IPDM E/R\)"](#) in HEADLAMP (FOR USA).

Front Fog Lamps Do Not Illuminate (Both Sides)

INFOID:000000001719089

1.CHECK COMBINATION SWITCH INPUT SIGNAL

Select "BCM" on CONSULT-III. With "HEAD LAMP" data monitor, make sure "FR FOG SW" turns ON-OFF linked with operation of lighting switch.

When lighting switch is in FOG position : FR FOG SW ON

OK or NG

- OK >> GO TO 2.
NG >> Check lighting switch. Refer to [LT-81, "Combination Switch Inspection"](#).

2.FOG LAMP ACTIVE TEST

1. Select "IPDM E/R" on CONSULT-III, and select "ACTIVE TEST" on "SELECT DIAG MODE" screen.
2. Select "LAMPS" on "SELECT TEST ITEM" screen.
3. Touch "FOG" on "ACTIVE TEST" screen.
4. Make sure fog lamps operate.

Fog lamps should operate.

OK or NG

- OK >> GO TO 3.
NG >> GO TO 4.

3.CHECK IPDM E/R

1. Select "IPDM E/R" on CONSULT-III, and select "DATA MONITOR" on "SELECT DIAG MODE" screen.
2. Make sure "FR FOG REQ" turns ON when lighting switch is in FOG position.

When lighting switch is in FOG position : FR FOG REQ ON

FRONT FOG LAMP

< SERVICE INFORMATION >

OK or NG

- OK >> Replace IPDM E/R. Refer to [PG-28, "Removal and Installation of IPDM E/R"](#).
- NG >> Replace BCM. Refer to [BCS-18, "Removal and Installation of BCM"](#).

4. IPDM E/R INSPECTION

1. Disconnect front fog lamp LH/RH harness connector.
2. Start auto active test. Refer to [PG-20, "Auto Active Test"](#). When front fog lamp relay is operating, check voltage between left/right front fog lamp connector terminals and ground.

Front fog lamp		(-)	Voltage (Approx.)
(+) Connector			
Terminal	Terminal		
RH	E101	+	Ground
LH	E102		
			Battery voltage

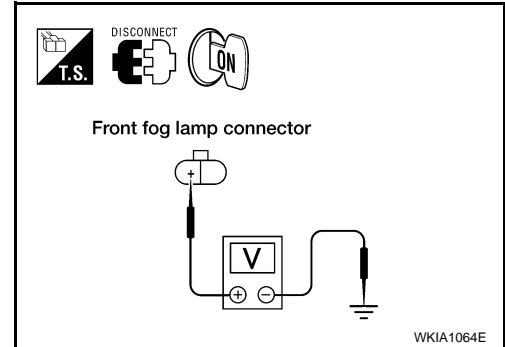

OK or NG

- OK >> Check front fog lamp bulbs and replace as necessary.
- NG >> Replace IPDM E/R. Refer to [PG-28, "Removal and Installation of IPDM E/R"](#).

Front Fog Lamp Does Not Illuminate (One Side)

INFOID:000000001719090

1. BULB INSPECTION

Inspect bulb of lamp which does not illuminate.

OK or NG

- OK >> GO TO 2.
- NG >> Replace fog lamp bulb. Refer to [LT-53, "Bulb Replacement"](#).

2. INSPECTION BETWEEN IPDM E/R AND FRONT FOG LAMPS

1. Disconnect IPDM E/R connector and inoperative front fog lamp connector.
2. Check continuity between harness connector terminals of IPDM E/R and inoperative front fog lamp harness connector terminal.

IPDM E/R		Front fog lamp		Continuity
Connector	Terminal	Connector	Terminal	
E124	36	RH	E101	+
	37	LH	E102	
				Yes

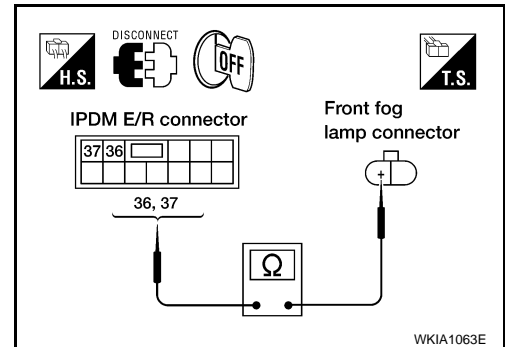

OK or NG

- OK >> Check ground circuit. If NG, repair harness or connector. If OK, replace IPDM E/R. Refer to [PG-28, "Removal and Installation of IPDM E/R"](#).
- NG >> Check for short circuits and open circuits in harness between IPDM E/R and inoperative front fog lamp.

Aiming Adjustment

INFOID:000000001719091

NOTE:

- If vehicle front body has been repaired and /or the fog lamp assembly has been replaced, check fog lamp aiming.
- Before performing aiming adjustment, check the following:
 - Ensure all tires are inflated to correct pressure.
 - Place vehicle and screen on level surface.
 - Ensure there is no load in vehicle other than the driver (or equivalent weight placed in driver's position). Coolant and engine oil is filled to correct level, and fuel tank full.
 - Confirm spare tire, jack and tools are properly stowed.

FRONT FOG LAMP

< SERVICE INFORMATION >

1. Set the distance between the screen and the center of the front fog lamp lens as shown.

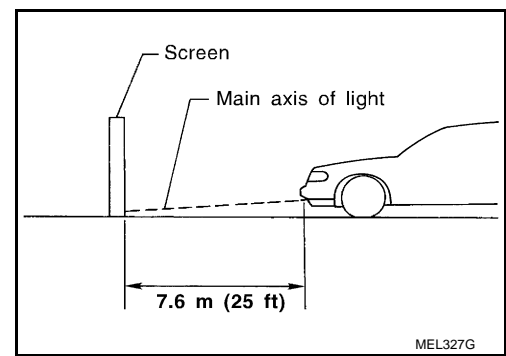

2. Position fender protector aside. Refer to [EI-21](#).
3. Turn front fog lamps ON and adjust front fog lamps using adjusting screw (1) so that the top edge of the high intensity zone is 100 mm (4 in) below the height of the front fog lamp centers as shown.

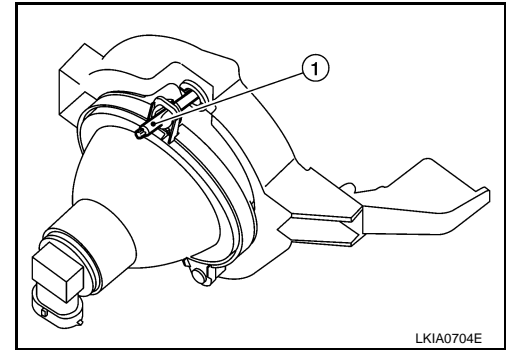

Bulb Replacement

INFOID:000000001719092

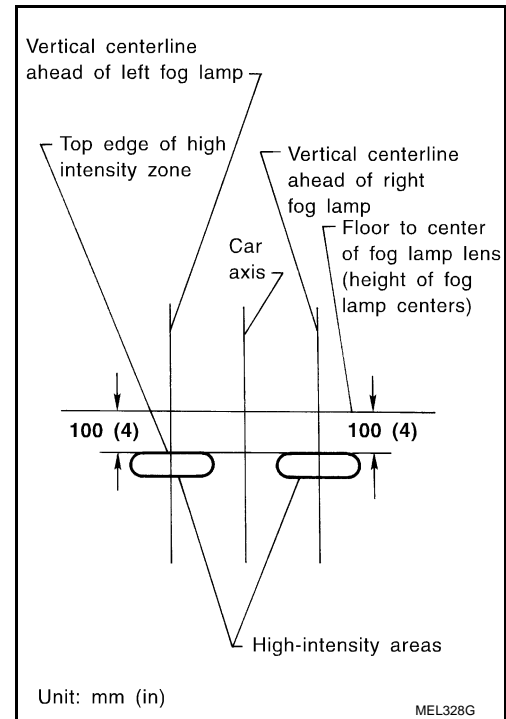

The front fog lamp is a semi-sealed beam type which uses a replaceable halogen bulb.

REMOVAL

CAUTION:

- Turn fog lamp switch OFF before disconnecting and connecting the connector.
- Do not touch bulb by hand while it is lit or right after being turned off. Burning may result.
- Grasp only the plastic base when handling the bulb. Never touch the glass envelope. Touching the glass could significantly affect the bulb life and/or fog lamp performance. Keep grease and other oily substances away from bulb.
- Do not leave bulb out of fog lamp reflector for a long time because dust, moisture, smoke, etc., may affect the performance of fog lamp. When replacing bulb, be sure to replace it with new one.

FRONT FOG LAMP

< SERVICE INFORMATION >

1. Position the front fender protector aside. Refer to [EI-21](#).
2. Disconnect electrical connector.
3. Turn the bulb socket counterclockwise and remove bulb.

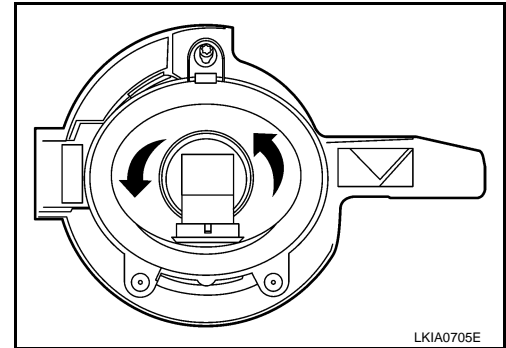

INSTALLATION

Installation is in the reverse order of removal.

Front Fog Lamp Assembly

INFOID:000000001719093

REMOVAL

CAUTION:

- Do not touch the glass of bulb directly by hand. Keep grease and other oily substances away from it. Do not touch bulb by hand while it is lit or right after being turned off. Burning may result.
- Grasp only the plastic base when handling the bulb. Never touch the glass envelope. Touching the glass could significantly affect the bulb life and/or fog lamp performance.
- Do not leave bulb out of fog lamp reflector for a long time because dust, moisture smoke, etc., may affect the performance of fog lamp. When replacing bulb, be sure to replace it with new one.

1. Position the fender protector aside. Refer to [EI-21](#).
2. Disconnect the electrical connector.
3. Remove the front fog lamp assembly.
 - Remove the screw (5).
 - Pull the bracket (2) toward the rear of vehicle to release the snap clip (1).
 - Remove the front fog lamp screws (3) and remove the front fog lamp housing (4).

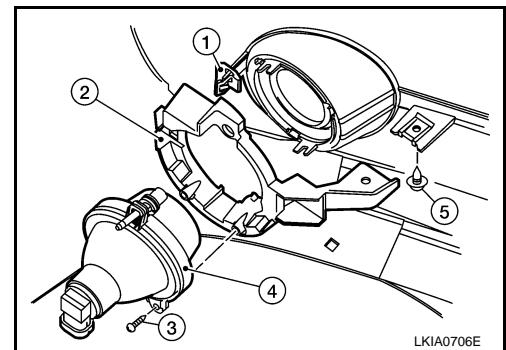

INSTALLATION

1. Install front fog lamp assembly.
 - Position the front fog lamp housing (4) and install the front fog lamp screws (3)
 - Press the bracket (2) onto the snap clip (1).
 - Install the screws (5).
2. Connect the electrical connector.
3. Verify fog lamp aiming. Refer to [LT-52, "Aiming Adjustment"](#).
4. Install the fender protector. Refer to [EI-21](#).

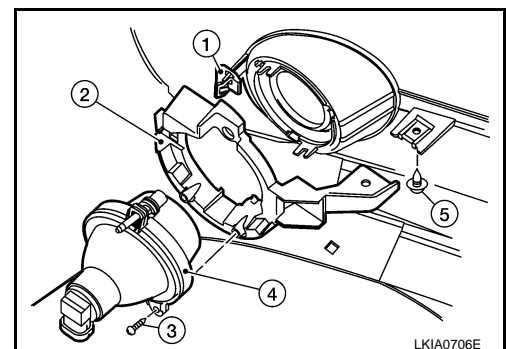

TURN SIGNAL AND HAZARD WARNING LAMPS

< SERVICE INFORMATION >

TURN SIGNAL AND HAZARD WARNING LAMPS

Component Parts and Harness Connector Location

INFOID:000000001719094

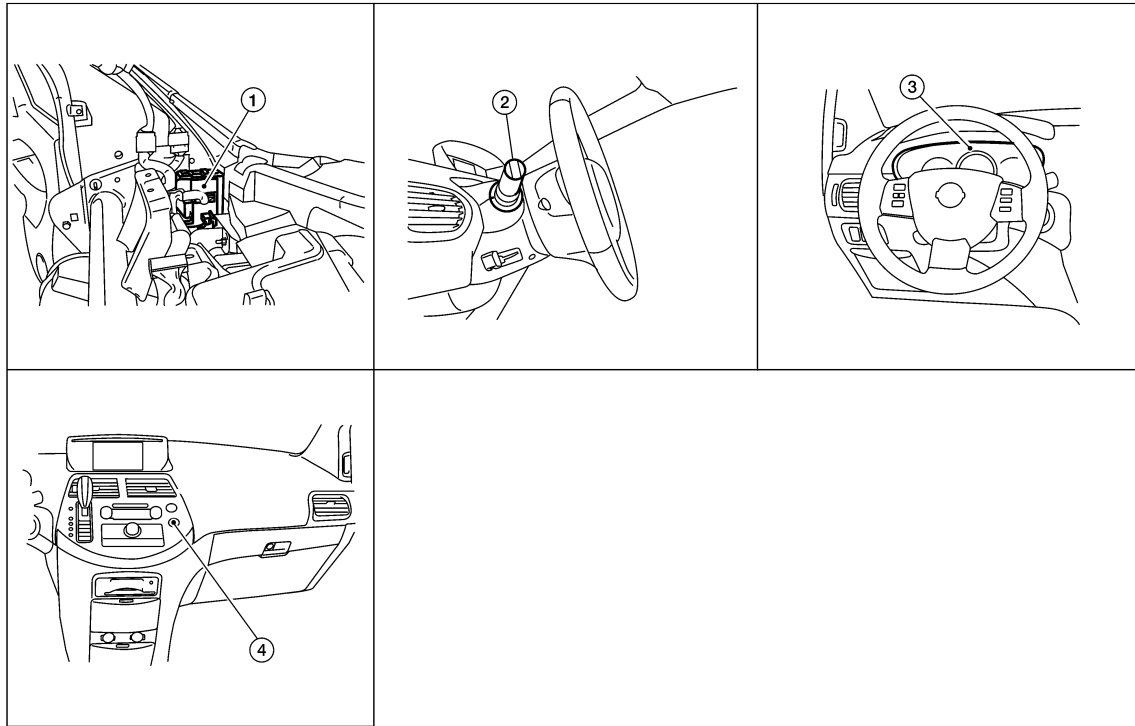

1. BCM M18, M19, M20 (view with instrument panel removed)
2. Combination switch (lighting switch) M28
3. Combination meter M24
4. Hazard switch M55

WKIA5263E

System Description

INFOID:000000001719095

OUTLINE

Power is supplied at all times

- through 50A fusible link (letter j, located in the fuse and fusible link box)
- to BCM (body control module) terminal 70, and
- through 15A fuse [No. 3, located in the fuse block (J/B)]
- to BCM terminal 57, and
- through 15A fuse [No. 19, located in the fuse block (J/B)]
- to combination meter terminal 40.

When the ignition switch is in the ON or START position, power is supplied

- through 10A fuse [No. 16, located in the fuse block (J/B)]
- to BCM terminal 38, and
- through 10A fuse [No. 14, located in the fuse block (J/B)]
- to combination meter terminal 38.

When the ignition switch is in the ACC or ON position, power is supplied

- through 10A fuse [No. 4, located in the fuse block (J/B)]
- to BCM terminal 11.

Ground is supplied

- to BCM terminal 67 and
- to combination meter terminal 20
- through grounds M57, M61 and M79.

TURN SIGNAL OPERATION

LH Turn

TURN SIGNAL AND HAZARD WARNING LAMPS

< SERVICE INFORMATION >

When the turn signal switch is moved to the left position, the BCM, interpreting it as turn signal is ON, outputs turn signal from BCM terminal 60.

The BCM supplies power

- through BCM terminal 60
- to front combination lamp LH terminal 7
- through front combination lamp LH terminal 6
- to grounds E9, E15 and E24, and
- to rear combination lamp LH terminal 3
- through rear combination lamp LH terminal 5
- to grounds B7 and B19.

BCM sends signal to combination meter through CAN communication lines and turns on turn signal indicator lamp within combination meter.

RH Turn

When the turn signal switch is moved to the right position, the BCM, interpreting it as turn signal is ON, outputs turn signal from BCM terminal 61.

The BCM supplies power

- through BCM terminal 61
- to front combination lamp RH terminal 7
- through front combination lamp RH terminal 6
- to grounds E9, E15 and E24, and
- to rear combination lamp RH terminal 3
- through rear combination lamp RH terminal 5
- to grounds B117 and B132.

BCM sends signal to combination meter through CAN communication lines and turns on turn signal indicator lamp within combination meter.

HAZARD LAMP OPERATION

When the hazard switch is depressed, ground is supplied

- to BCM terminal 29
- through hazard switch terminal 2
- through hazard switch terminal 1
- through grounds M57, M61 and M79.

When the hazard switch is depressed, the BCM, interpreting it as hazard warning lamps are ON, outputs turn signal from BCM terminals 60 and 61.

The BCM supplies power

- through BCM terminals 60 and 61
- to front combination lamp LH and RH terminal 7
- through front combination lamp LH and RH terminal 6
- to grounds E9, E15 and E24, and
- to rear combination lamp LH terminal 3
- through rear combination lamp LH terminal 5
- to grounds B7 and B19, and
- to rear combination lamp RH terminal 3
- through rear combination lamp RH terminal 5
- to grounds B117 and B132.

BCM sends signal to combination meter through CAN communication lines and turns on turn signal indicator lamps within combination meter.

REMOTE KEYLESS ENTRY SYSTEM OPERATION

When the remote keyless entry system is triggered by input from the keyfob, the BCM, interpreting it as turn signal is ON, outputs turn signal from BCM terminals 60 and 61.

The BCM supplies power

- through BCM terminals 60 and 61
- to front combination lamp LH and RH terminal 7
- through front combination lamp LH and RH terminal 6
- to grounds E9, E15 and E24, and
- to rear combination lamp LH terminal 3
- through rear combination lamp LH terminal 5
- to grounds B7 and B19, and
- to rear combination lamp RH terminal 3
- through rear combination lamp RH terminal 5

TURN SIGNAL AND HAZARD WARNING LAMPS

< SERVICE INFORMATION >

- to grounds B117 and B132.

BCM sends signal to combination meter through CAN communication lines and turns on turn signal indicator lamps within combination meter.

With power and input supplied, the BCM controls the flashing of the hazard warning lamps when keyfob is used to activate the remote keyless entry system.

COMBINATION SWITCH READING FUNCTION

Refer to [BCS-3, "System Description"](#).

CAN Communication System Description

INFOID:000000001719096

Refer to [LAN-3, "CAN Communication System"](#).

A
B
C
D
E
F
G
H
I
J
LT
L
M
N
O
P

TURN SIGNAL AND HAZARD WARNING LAMPS

< SERVICE INFORMATION >

Schematic

INFOID:000000001719097

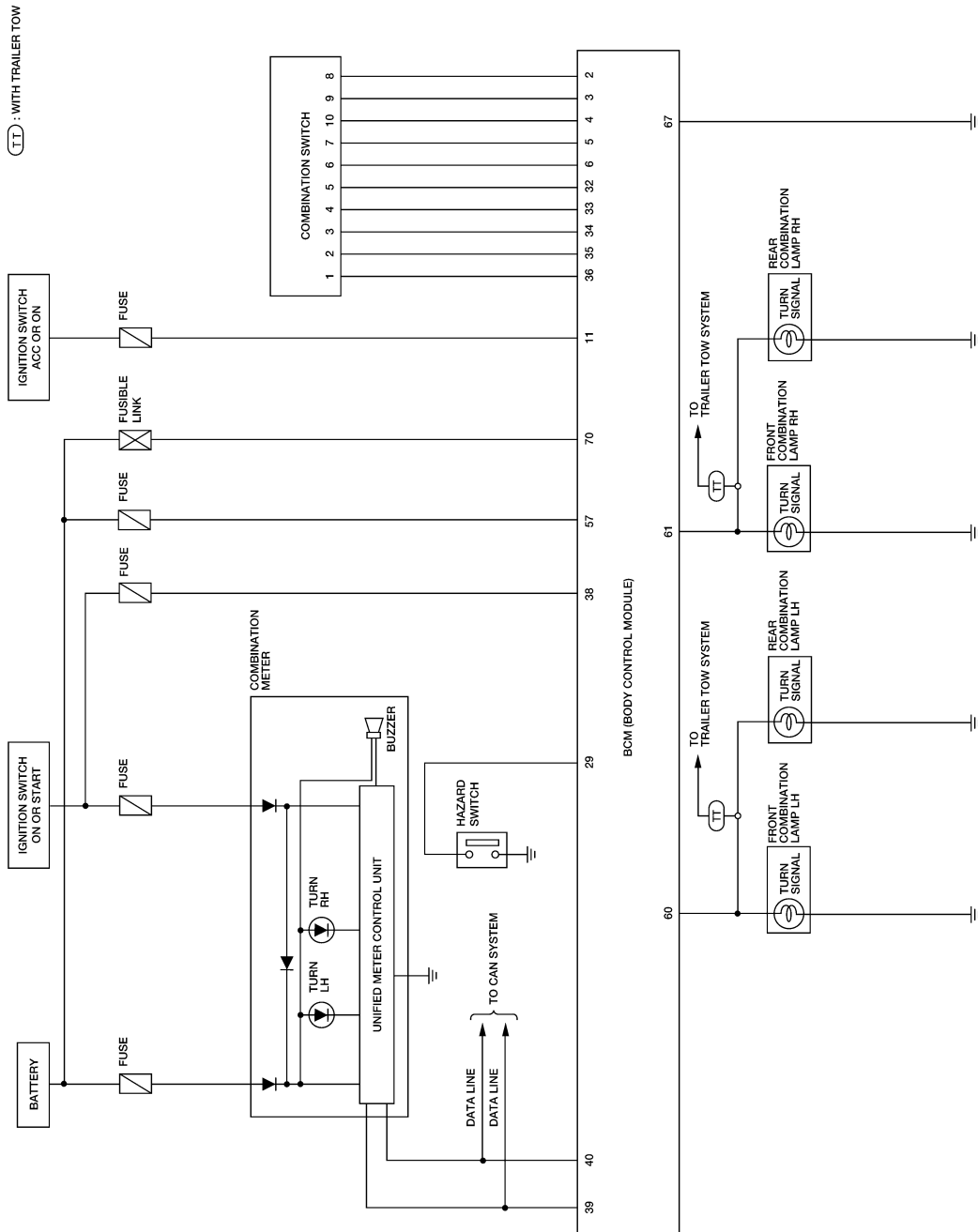

WKWA4694E

TURN SIGNAL AND HAZARD WARNING LAMPS

< SERVICE INFORMATION >

LT-TURN-02

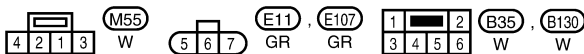
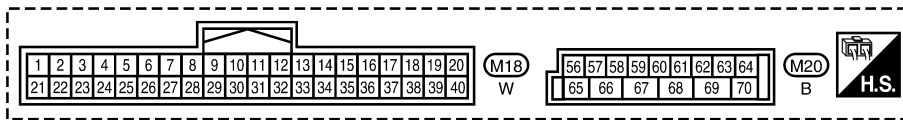
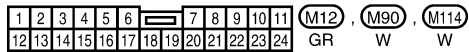
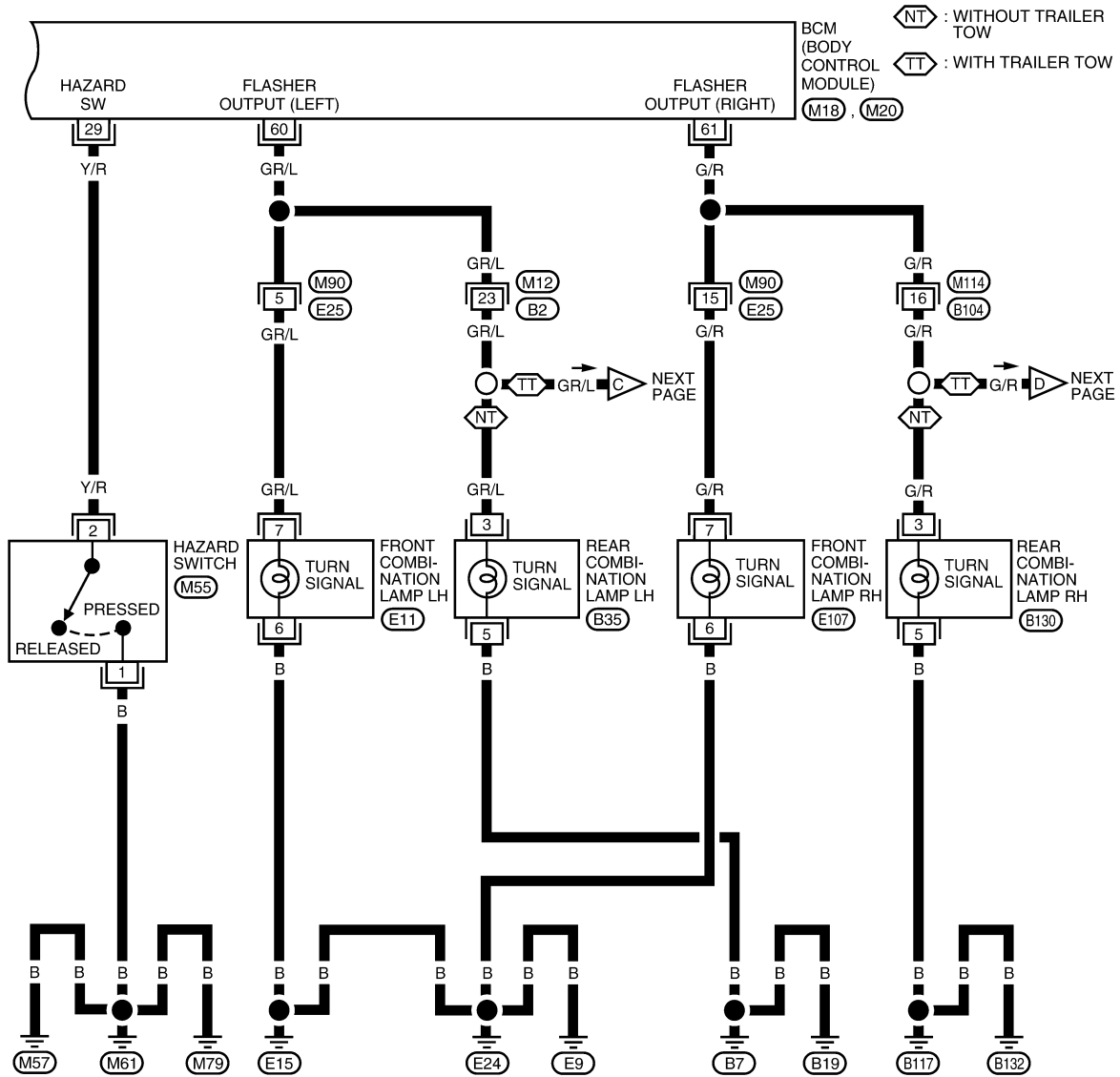

WKWA4696E

TURN SIGNAL AND HAZARD WARNING LAMPS

< SERVICE INFORMATION >

LT-TURN-03

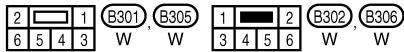
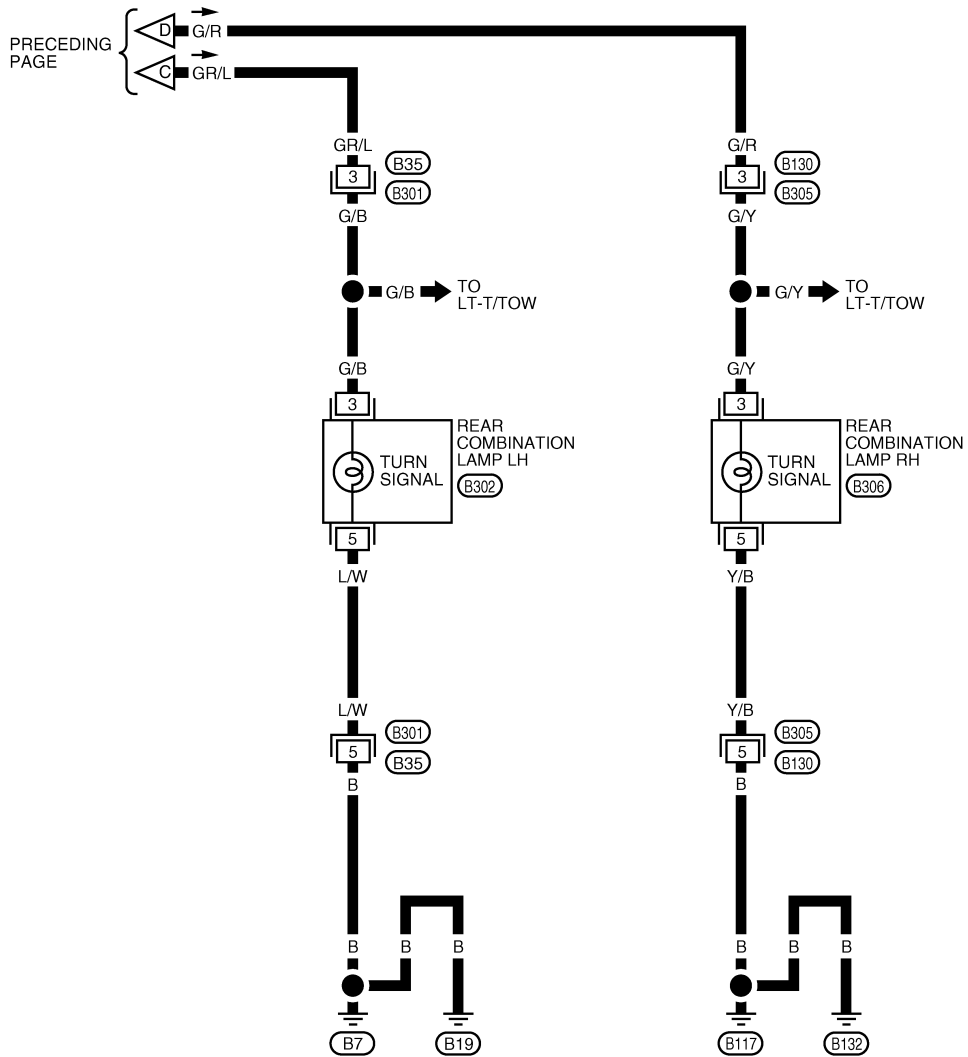

A
B
C
D
E
F
G
H
I
J
K
L
M
N
O
P

LT

WKWA4697E

TURN SIGNAL AND HAZARD WARNING LAMPS

< SERVICE INFORMATION >

LT-TURN-04

▬ : DATA LINE

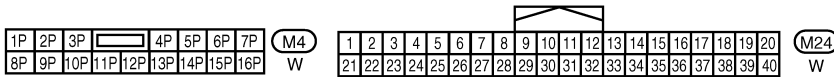
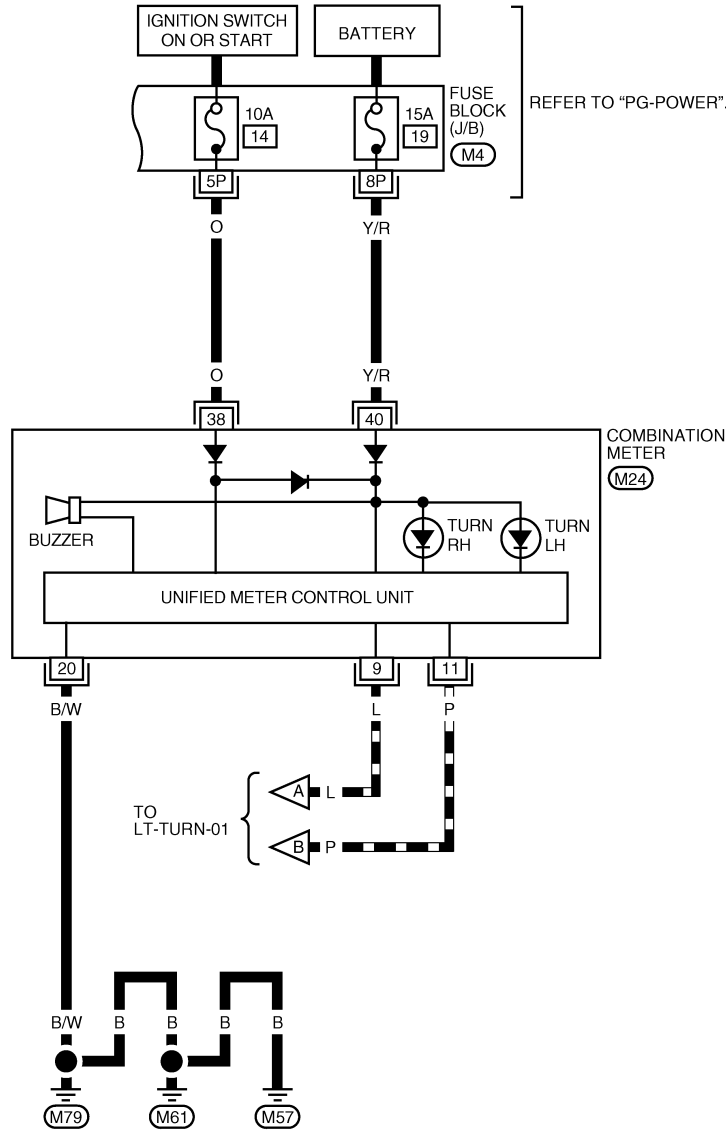

WKWA4698E

INFOID:000000001719099

Terminal and Reference Value for BCM

Refer to [BCS-11, "Terminal and Reference Value for BCM"](#).

How to Proceed with Trouble Diagnosis

INFOID:000000001719100

1. Confirm the symptom or customer complaint.
2. Understand operation description and function description. Refer to [LT-55, "System Description"](#).

TURN SIGNAL AND HAZARD WARNING LAMPS

< SERVICE INFORMATION >

3. Perform preliminary check. Refer to [LT-63. "BCM Power Supply and Ground Circuit Inspection"](#).
4. Check symptom and repair or replace the cause of malfunction.
5. Do turn signal and hazard warning lamps operate normally? If YES: GO TO 6. If NO: GO TO 4.
6. Inspection End.

BCM Power Supply and Ground Circuit Inspection

INFOID:000000001719101

Refer to [BCS-15. "BCM Power Supply and Ground Circuit Inspection"](#).

CONSULT-III Function (BCM)

INFOID:000000001719102

CONSULT-III can display each diagnostic item using the diagnostic test modes shown following.

BCM diagnostic test item	Diagnostic mode	Description
Inspection by part	WORK SUPPORT	Supports inspections and adjustments. Commands are transmitted to the BCM for setting the status suitable for required operation, input/output signals are received from the BCM and received data is displayed.
	DATA MONITOR	Displays BCM input/output data in real time.
	ACTIVE TEST	Operation of electrical loads can be checked by sending drive signal to them.
	SELF-DIAG RESULTS	Displays BCM self-diagnosis results.
	CAN DIAG SUPPORT MNTR	The result of transmit/receive diagnosis of CAN communication can be read.
	ECU PART NUMBER	BCM part number can be read.
	CONFIGURATION	Performs BCM configuration read/write functions.

DATA MONITOR

Operation Procedure

1. Touch "FLASHER" on "SELECT TEST ITEM" screen.
2. Touch "DATA MONITOR" on "SELECT DIAG MODE" screen.
3. Touch either "ALL SIGNALS" or "SELECTION FROM MENU" on the "SELECT MONITOR ITEM" screen.

ALL SIGNALS	Monitors all the signals.
SELECTION FROM MENU	Selects and monitors the individual signal.

4. Touch "START".
5. When "SELECTION FROM MENU" is selected, touch items to be monitored. When "ALL SIGNALS" is selected, all the items will be monitored.
6. Touch "RECORD" while monitoring, then the status of the monitored item can be recorded. To stop recording, touch "STOP".

Display Item List

Monitor item	Contents
IGN ON SW "ON/OFF"	Displays "IGN position (ON)/OFF, ACC position (OFF)" judged from the ignition switch signal.
HAZARD SW "ON/OFF"	Displays "Hazard ON (ON)/Hazard OFF (OFF)" status, determined from hazard switch signal.
TURN SIGNAL R "ON/OFF"	Displays "Turn right (ON)/Other (OFF)" status, determined from lighting switch signal.
TURN SIGNAL L "ON/OFF"	Displays "Turn left (ON)/Other (OFF)" status, determined from lighting switch signal.
BRAKE SW "OFF"	Displays status of parking brake switch.

ACTIVE TEST

Operation Procedure

1. Touch "FLASHER" on "SELECT TEST ITEM" screen.
2. Touch "ACTIVE TEST" on "SELECT DIAG MODE" screen.
3. Touch item to be tested and check operation of the selected item.

TURN SIGNAL AND HAZARD WARNING LAMPS

< SERVICE INFORMATION >

4. During the operation check, touching "BACK" deactivates the operation.

Display Item List

Test item	Description
FLASHER (RH)	Turn signal lamp (RH) can be operated by any ON-OFF operations.
FLASHER (LH)	Turn signal lamp (LH) can be operated by any ON-OFF operations.

Front Turn Signal Lamp Does Not Operate

INFOID:000000001719103

1. CHECK COMBINATION SWITCH INPUT SIGNAL

With CONSULT-III

Select "BCM" on CONSULT-III. With "FLASHER" data monitor, make sure "TURN SIGNAL R" and "TURN SIGNAL L" turns ON-OFF linked with operation of lighting switch.

**When lighting switch is in : TURN SIGNAL R ON
TURN RH position**

**When lighting switch is in : TURN SIGNAL L ON
TURN LH position**

Without CONSULT-III

Refer to [LT-81, "Combination Switch Inspection"](#).

OK or NG

OK >> GO TO 2.

NG >> Check lighting switch. Refer to [LT-81, "Combination Switch Inspection"](#).

2. ACTIVE TEST

With CONSULT-III

- Select "FLASHER" during active test. Refer to [LT-63, "CONSULT-III Function \(BCM\)"](#).
- Make sure "FLASHER RH" and "FLASHER LH" operate.

Without CONSULT-III

GO TO 3.

OK or NG

OK >> Replace BCM. Refer to [BCS-18, "Removal and Installation of BCM"](#).

NG >> GO TO 3.

3. CHECK TURN SIGNAL LAMP CIRCUIT

- Turn ignition switch OFF.
- Disconnect BCM connector and inoperative front combination lamp harness connector.
- Check continuity between BCM harness connector terminal and inoperative front combination lamp harness connector terminal.

A		B		Continuity
BCM connector	Terminal	Front combination lamp connector	Terminal	
RH	M20	RH	E107	Yes
LH		LH	E11	
			6	

OK or NG

OK >> GO TO 4.

NG >> Repair harness or connector.

4. CHECK GROUND

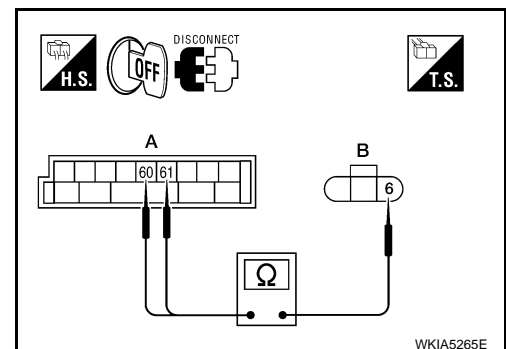

TURN SIGNAL AND HAZARD WARNING LAMPS

< SERVICE INFORMATION >

Check continuity between inoperative front combination lamp harness connector terminal and ground.

Front combination lamp connector		Terminal		Continuity
RH	E107	5	Ground	Yes
LH	E11			

OK or NG

- OK >> GO TO 5.
- NG >> Repair harness or connector.

5.CHECK BULB

Check bulb standard of each turn signal lamp is correct. Refer to [LT-140, "Exterior Lamp"](#).

OK or NG

- OK >> Replace BCM if turn signal lamps do not work after setting the connector again. Refer to [BCS-18, "Removal and Installation of BCM"](#).
- NG >> Replace turn signal lamp bulb. Refer to [LT-67, "Bulb Replacement"](#).

Rear Turn Signal Lamp Does Not Operate

INFOID:000000001719104

1.CHECK TAIL LAMPS AND STOP LAMPS

Check bulb standard of each turn signal lamp is correct. Refer to [LT-140, "Exterior Lamp"](#).

OK or NG

- OK >> GO TO 2.
- NG >> Replace turn signal lamp bulb. Refer to [LT-67, "Bulb Replacement"](#).

2.CHECK TURN SIGNAL LAMPS CIRCUIT

1. Disconnect BCM connector and rear combination lamp connector.
2. Check continuity between BCM (A) connector M20 terminal 61 and rear combination lamp RH (B) connector B130 (without trailer tow), B306 (with trailer tow) terminal 3.

61 - 3 : Continuity should exist.

3. Check continuity between BCM (A) connector M20 terminal 60 and rear combination lamp LH harness connector B35 (without trailer tow), B302 (with trailer tow) terminal 3.

60 - 3 : Continuity should exist.

OK or NG

- OK >> GO TO 3.
- NG >> Repair harness or connector.

3.CHECK GROUND CIRCUIT

Check continuity between rear combination lamp harness connector B35 (without trailer tow), B302 (with trailer tow) LH and B130 (without trailer tow), B306 (with trailer tow) RH terminal 5 and ground.

5 - Ground : Continuity should exist.

OK or NG

- OK >> Check rear combination lamp connector for proper connection. Repair as necessary.
- NG >> Repair harness or connector.

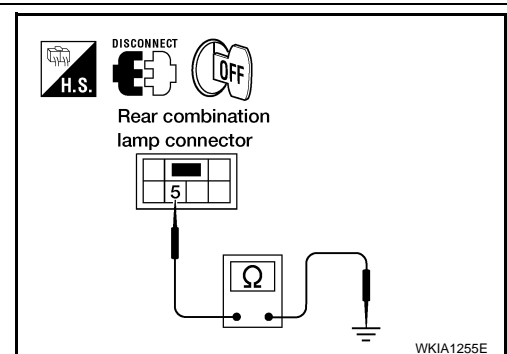
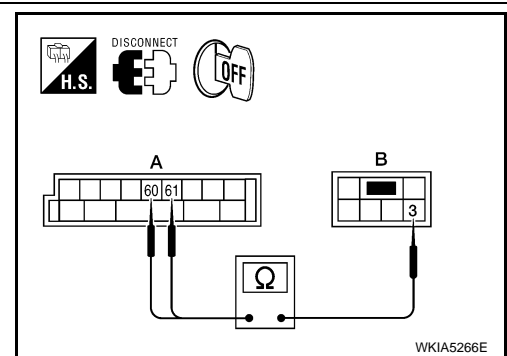
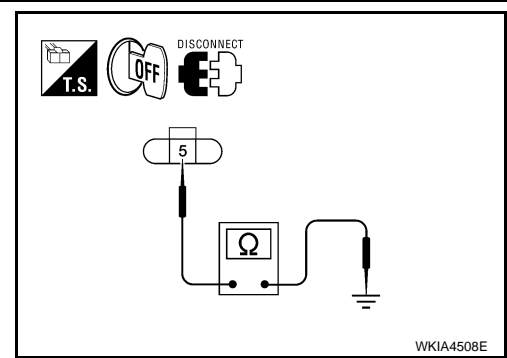

TURN SIGNAL AND HAZARD WARNING LAMPS

< SERVICE INFORMATION >

Hazard Warning Lamp Does Not Operate But Turn Signal Lamp Operates INFOID:000000001719105

1. CHECK BULB

Make sure bulb standard of each turn signal lamp is correct. Refer to [LT-140, "Exterior Lamp"](#).

OK or NG

OK >> GO TO 2.

NG >> Replace turn signal lamp bulb. Refer to [LT-67, "Bulb Replacement"](#) for front turn signal bulb. Refer to [LT-67, "Bulb Replacement"](#) for rear turn signal bulb.

2. CHECK HAZARD SWITCH INPUT SIGNAL

 With CONSULT-III

Select "BCM" on CONSULT-III. With "FLASHER" data monitor, make sure "HAZARD SW" turns ON-OFF linked with operation of hazard switch.

**When hazard switch is in : HAZARD SW ON
ON position**

 Without CONSULT-III

Check voltage between BCM harness connector M18 terminal 29 and ground.

BCM (+)		(-)	Condition	Voltage (Approx.)
Connector	Terminal			
M18	29	Ground	Hazard switch is ON	0V
			Hazard switch is OFF	5V

OK or NG

OK >> Replace BCM. Refer to [BCS-18, "Removal and Installation of BCM"](#).

NG >> GO TO 3.

3. CHECK HAZARD SWITCH CIRCUIT

1. Turn ignition switch OFF.
2. Disconnect BCM connector and hazard switch connector.
3. Check continuity between BCM harness connector M18 terminal 29 and hazard switch harness connector M55 terminal 2.

29 - 2 : Continuity should exist.

OK or NG

OK >> GO TO 4.

NG >> Repair harness or connector.

4. CHECK GROUND

Check continuity between hazard switch harness connector M55 terminal 1 and ground.

1 - Ground : Continuity should exist.

OK or NG

OK >> GO TO 5.

NG >> Repair harness or connector.

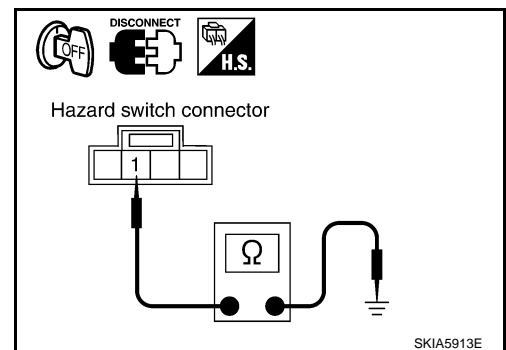
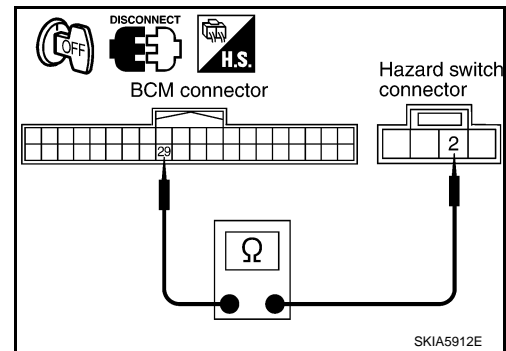
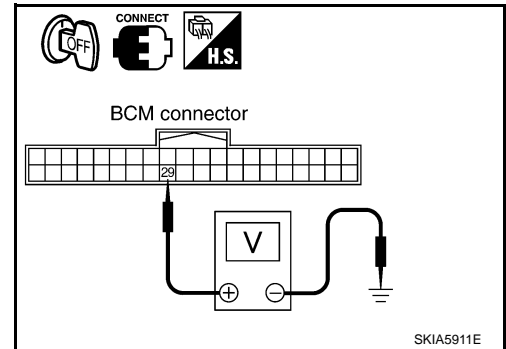

TURN SIGNAL AND HAZARD WARNING LAMPS

< SERVICE INFORMATION >

5. CHECK HAZARD SWITCH

Check continuity of hazard switch.

Hazard switch		Condition	Continuity
Terminal			
1	2	Hazard switch is ON	Yes
		Hazard switch is OFF	No

OK or NG

OK >> Replace BCM if hazard warning lamps do not work after setting the connector again. Refer to [BCS-18, "Removal and Installation of BCM"](#).

NG >> Replace hazard switch. Refer to [LT-78, "Removal and Installation"](#).

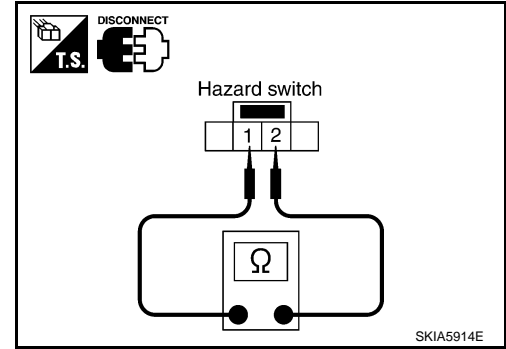

Turn Signal Indicator Lamp Does Not Operate

INFOID:000000001719106

1. CHECK CAN COMMUNICATION SYSTEM

Check CAN communication. Refer to [LAN-6, "Condition of Error Detection"](#).

OK or NG

OK >> Replace combination meter. Refer to [IP-12, "Combination Meter"](#).

NG >> Repair as necessary.

Bulb Replacement

INFOID:000000001719107

FRONT TURN SIGNAL LAMP

Refer to [LT-22, "Bulb Replacement"](#).

REAR TURN SIGNAL LAMP

Refer to [LT-102, "Bulb Replacement"](#).

Removal and Installation

INFOID:000000001719108

FRONT TURN SIGNAL LAMP

Refer to [LT-23, "Removal and Installation"](#).

REAR TURN SIGNAL LAMP

Refer to [LT-102, "Removal and Installation"](#).

A
B
C
D
E
F
G
H
I
J
LT
L
M
N
O
P

CORNERING LAMP

< SERVICE INFORMATION >

CORNERING LAMP

Component Parts and Harness Connector Location

INFOID:000000001719109

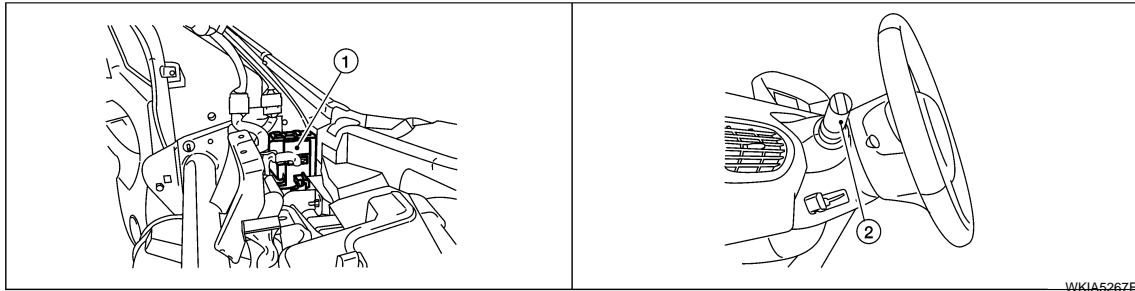

1. BCM M18, M20 (view with instrument panel removed)
2. Combination switch (lighting switch) M28

System Description

INFOID:000000001719110

OUTLINE

Power is supplied at all times

- to ignition relay, located in the IPDM E/R, and
- through 50A fusible link (letter j, located in the fuse and fusible link box)
- to BCM (body control module) terminal 70, and
- through 15A fuse [No. 3, located in the fuse block (J/B)]
- to BCM terminal 57, and
- through 15A fuse (No. 34, located in the IPDM E/R)
- to CPU (central processing unit) of the IPDM E/R, and
- through 15A fuse (No. 41, located in the IPDM E/R)
- to cornering lamp relay LH and RH, and
- to CPU (central processing unit) of the IPDM E/R.

When the ignition switch is in the ON or START position, power is supplied

- to ignition relay, located in the IPDM E/R, and
- through 10A fuse [No. 16, located in the fuse block (J/B)]
- to BCM terminal 38.

When the ignition switch is in the ACC or ON position, power is supplied

- through 10A fuse [No. 4, located in the fuse block (J/B)]
- to BCM terminal 11.

Ground is supplied

- to BCM terminal 67
- through grounds M57, M61 and M79, and
- to IPDM E/R terminals 38 and 60
- through grounds E9, E15 and E24.

CORNERING LAMP OPERATION

LH Turn

When the lighting switch is in the 2nd position or in the AUTO position (headlamp ON) and turn signal switch is moved to the left position, BCM sends signal through CAN communication lines to IPDM E/R. IPDM E/R then operates cornering lamp relay LH. When this relay is energized, power is supplied

- through IPDM E/R terminal 34
- to front combination lamp LH terminal 9.

Ground is supplied

- to front combination lamp LH terminal 8
- through grounds E9, E15 and E24.

RH Turn

When the lighting switch is in the 2nd position or in the AUTO position (headlamp ON) and turn signal switch is moved to the right position, BCM sends signal through CAN communication lines to IPDM E/R. IPDM E/R then operates cornering lamp relay RH. When this relay is energized, power is supplied

CORNERING LAMP

< SERVICE INFORMATION >

- through IPDM E/R terminal 23
- to front combination lamp RH terminal 9.
Ground is supplied
- to front combination lamp RH terminal 8
- through grounds E9, E15 and E24.

COMBINATION SWITCH READING FUNCTION

Refer to [BCS-3, "System Description"](#).

CAN Communication System Description

Refer to [LAN-3, "CAN Communication System"](#).

INFOID:000000001719111

A
B
C
D
E
F
G
H
I
J
LT
L
M
N
O
P

CORNERING LAMP

< SERVICE INFORMATION >

Schematic

INFOID:000000001719112

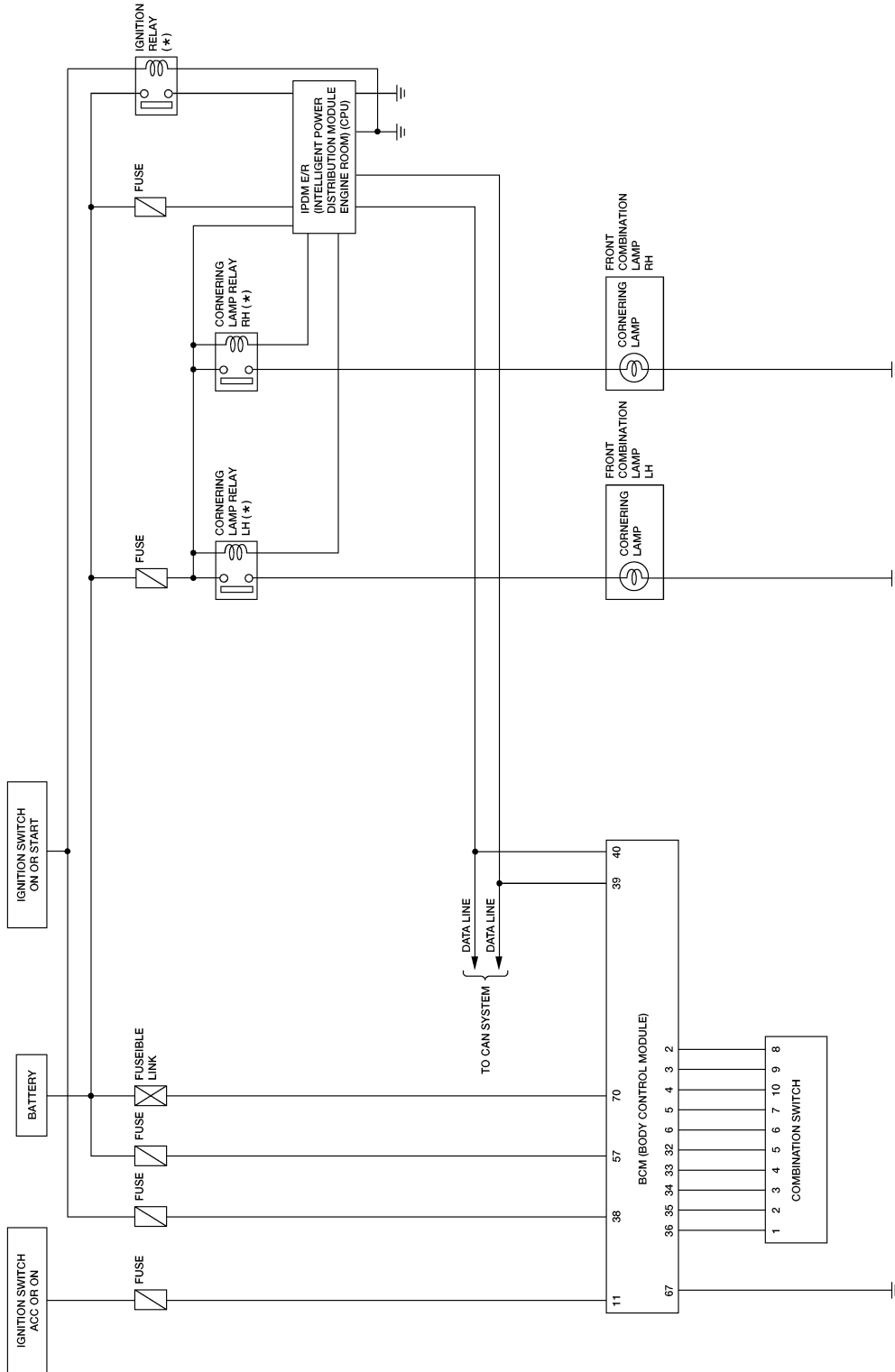

* : THIS RELAY IS BUILT INTO THE IPDM E/R (INTELLIGENT POWER DISTRIBUTION MODULE ENGINE ROOM)

WKWA4699E

CORNERING LAMP

< SERVICE INFORMATION >

LT-CORNER-02

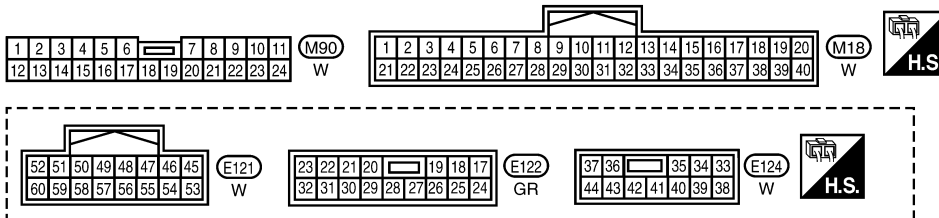
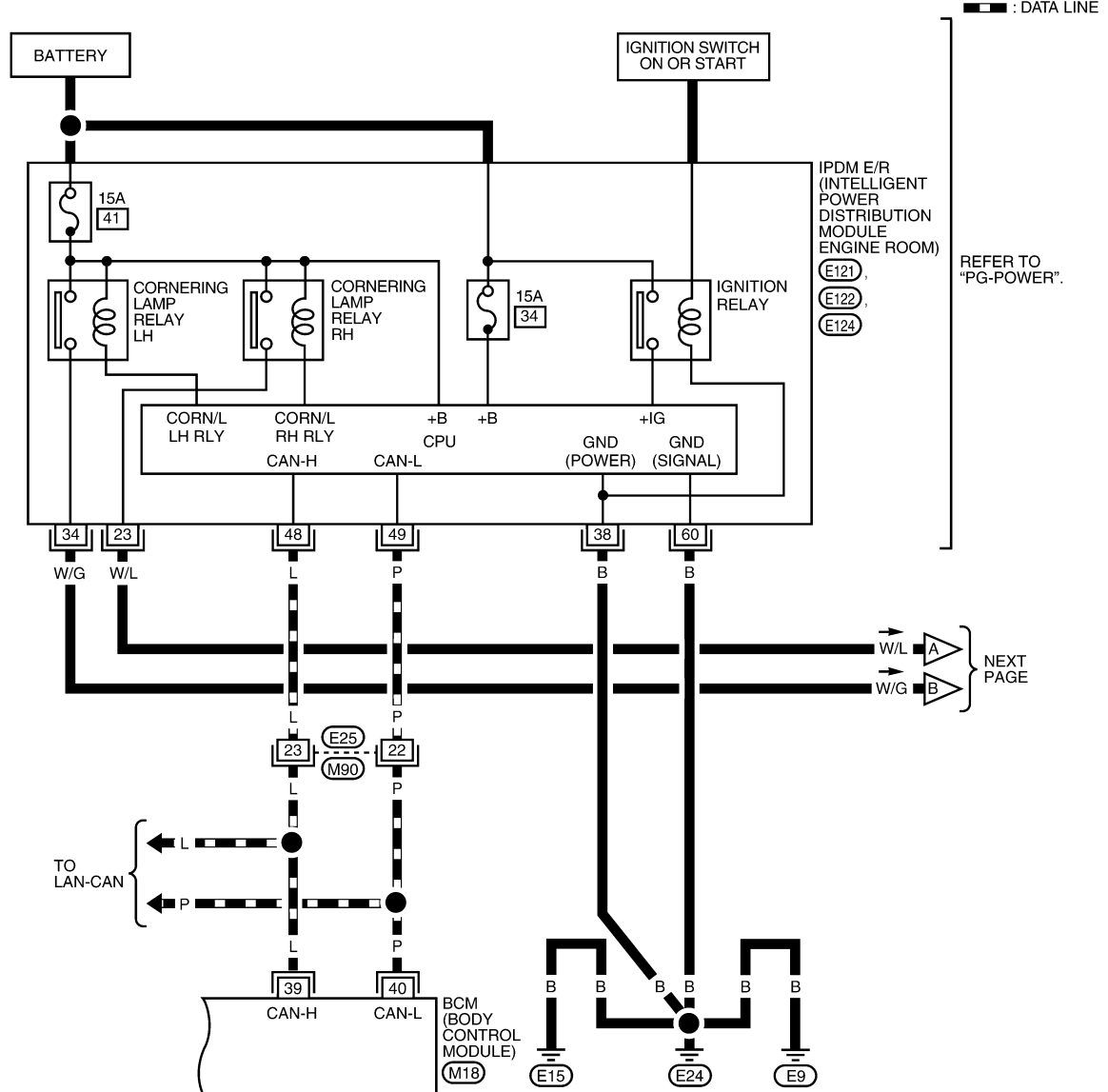

ALLWA0139GB

CORNERING LAMP

< SERVICE INFORMATION >

LT-CORNER-03

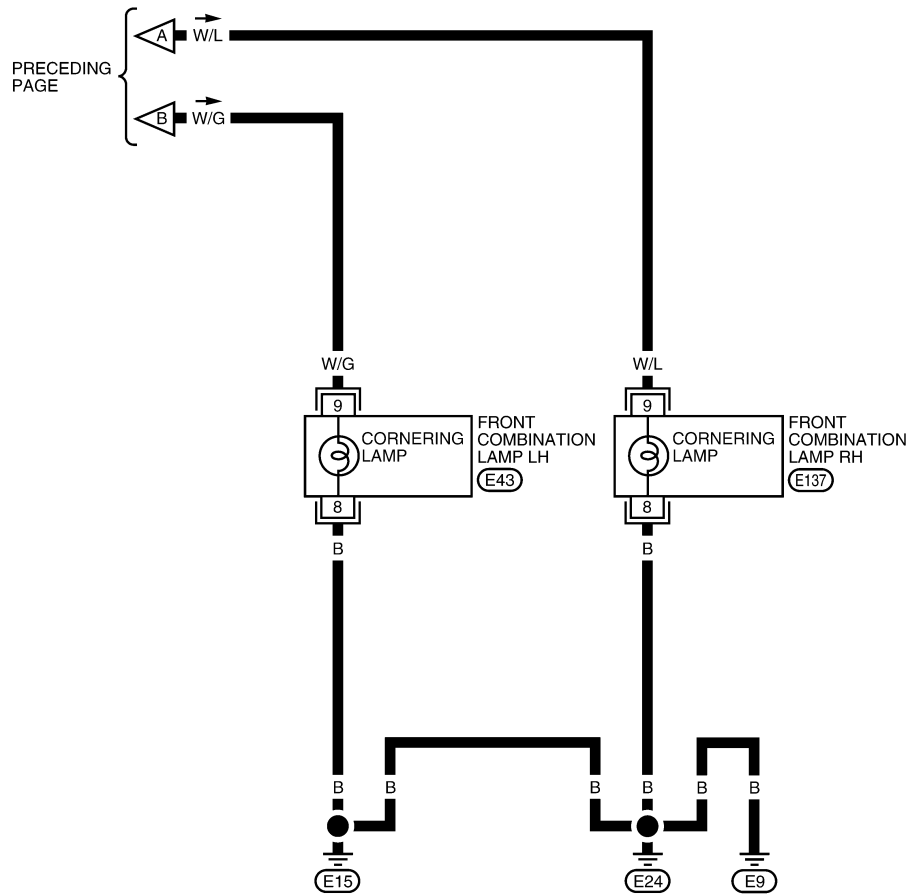

Terminal and Reference Value for BCM

Refer to [BCS-11, "Terminal and Reference Value for BCM"](#).

Terminal and Reference Value for IPDM E/R

Refer to [PG-24, "Terminal and Reference Value for IPDM E/R"](#).

ALLWA0140GB

INFOID:000000001719114

INFOID:000000001719115

A
B
C
D
E
F
G
H
I
J
LT
L
M
N
O
P

CORNERING LAMP

< SERVICE INFORMATION >

How to Proceed with Trouble Diagnosis

INFOID:000000001719116

1. Confirm the symptom or customer complaint.
2. Understand operation description and function description. Refer to [LT-68, "System Description"](#).
3. Perform preliminary check. Refer to [LT-74, "Preliminary Check"](#).
4. Check symptom and repair or replace the cause of malfunction.
5. Do turn signal and hazard warning lamps operate normally? If YES: GO TO 6. If NO: GO TO 4.
6. Inspection End.

Preliminary Check

INFOID:000000001719117

CHECK POWER SUPPLY AND GROUND CIRCUIT

Refer to [BCS-15, "BCM Power Supply and Ground Circuit Inspection"](#) and [PG-27, "IPDM E/R Power/Ground Circuit Inspection"](#)

CONSULT-III Function (IPDM E/R)

INFOID:000000001719118

CONSULT-III can display each diagnostic item using the diagnostic test modes shown following.

IPDM E/R diagnostic Mode	Description
SELF-DIAG RESULTS	Displays IPDM E/R self-diagnosis results.
DATA MONITOR	Displays IPDM E/R input/output data in real time.
CAN DIAG SUPPORT MNTR	The result of transmit/receive diagnosis of CAN communication can be read.
ACTIVE TEST	Operation of electrical loads can be checked by sending drive signal to them.

DATA MONITOR

Operation Procedure

1. Touch "DATA MONITOR" on "SELECT DIAG MODE" screen.
2. Touch "ALL SIGNALS" or "SELECTION FROM MENU" on "SELECT MONITOR ITEM" screen.

ALL SIGNALS	Monitors all the signals.
SELECTION FROM MENU	Selects and monitors the individual signal.

3. Touch "START".
4. When "SELECTION FROM MENU" is selected, touch items to be monitored. When "ALL SIGNALS" is selected, all the items will be monitored.
5. Touch "RECORD" while monitoring, then the status of the monitored item can be recorded. To stop recording, touch "STOP".

All Signals, Main Signals, Selection From Menu

Item name	CONSULT-III screen display	Display or unit	Monitor item selection			Description
			ALL SIGNALS	MAIN SIGNALS	SELECTION FROM MENU	
Cornering lamp	CRNRNG LMP REQ	ON/OFF	×	—	×	Signal status input from BCM

NOTE:

Perform monitoring of IPDM E/R data with the ignition switch ON. When the ignition switch is at ACC, the display may not be correct.

ACTIVE TEST

Operation Procedure

1. Touch "ACTIVE TEST" on "SELECT DIAG MODE" screen.
2. Touch "CORNERING LAMP" on "SELECT TEST ITEM" screen.
3. Touch "RH" or "LH" item to be tested and check operation of the selected item.

CORNERING LAMP

< SERVICE INFORMATION >

4. During the operation check, touching "BACK" deactivates the operation.

Display Item List

Test item	Description
CORNERING LAMP (RH)	Cornering lamp (RH) can be operated by any ON-OFF operations.
CORNERING LAMP (LH)	Cornering lamp (LH) can be operated by any ON-OFF operations.

Cornering Lamp Does Not Operate

INFOID:000000001719119

1. ACTIVE TEST

With CONSULT-III

1. Select "IPDM E/R" on CONSULT-III, and select "ACTIVE TEST" on "SELECT DIAG MODE" screen.
2. Select "CORNERING LAMP" during active test.
3. Select "RH", then "LH" on "ACTIVE TEST" screen.
4. Make sure cornering lamp LH and RH operate.

Without CONSULT-III

GO TO 3.

OK or NG

- OK >> GO TO 2.
 NG >> GO TO 3.

2. CHECK COMBINATION SWITCH INPUT SIGNAL

1. Select "IPDM E/R" on CONSULT-III, and select "DATA MONITOR" on "SELECT DIAG MODE" screen.
2. Make sure "CRNRNG LMP REQ" turns ON-OFF linked with operation of lighting switch.

NOTE:

Lighting switch must not be in OFF position.

**When lighting switch is in : CRNRNG LMP REQ R
 TURN RH position**

**When lighting switch is in : CRNRNG LMP REQ L
 TURN LH position**

OK or NG

- OK >> Replace IPDM E/R. Refer to [PG-28. "Removal and Installation of IPDM E/R"](#).
 NG >> Replace BCM. Refer to [BCS-18. "Removal and Installation of BCM"](#).

3. CHECK BULB

Check bulb standard of each cornering lamp is correct. Refer to [LT-140. "Exterior Lamp"](#).

OK or NG

- OK >> GO TO 4.
 NG >> Replace cornering lamp bulb. Refer to [LT-76. "Bulb Replacement"](#).

4. CHECK CORNERING LAMPS CIRCUIT

1. Turn ignition switch OFF.
2. Disconnect IPDM E/R connectors and front combination lamp LH and RH connectors.
3. Check continuity between IPDM E/R harness connector terminal and front combination lamp harness connector terminal.

A		B		Continuity
IPDM E/R connector	Terminal	Front combination lamp connector	Terminal	
RH	E122	RH	E137	Yes
LH	E124	LH	E43	

OK or NG

- OK >> GO TO 5.
 NG >> Repair harness or connector.

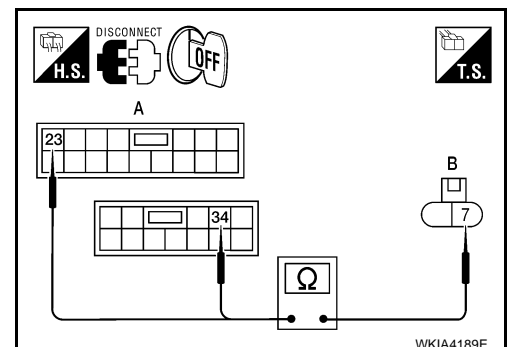

CORNERING LAMP

< SERVICE INFORMATION >

5. CHECK GROUND

Check continuity between front combination lamp harness connector terminal and ground.

Terminals		Terminal		Continuity
Front combination lamp connector				
RH	E137	8	Ground	No
LH	E43			

OK or NG

OK >> Replace IPDM E/R. Refer to [PG-28. "Removal and Installation of IPDM E/R"](#).

NG >> Repair harness or connector.

Bulb Replacement

INFOID:000000001719120

Refer to ["LT-22. "Bulb Replacement"](#).

Removal and Installation

INFOID:000000001719121

Refer to ["LT-23. "Removal and Installation"](#).

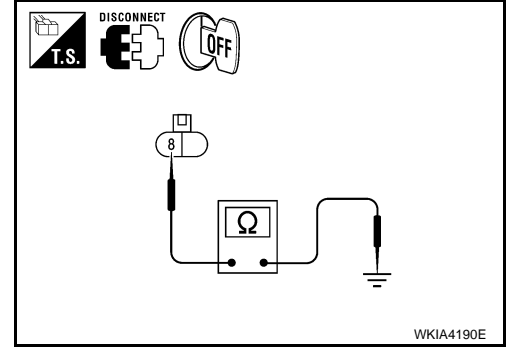

LIGHTING AND TURN SIGNAL SWITCH

< SERVICE INFORMATION >

LIGHTING AND TURN SIGNAL SWITCH

Removal

INFOID:000000001719122

1. Remove steering column cover. Refer to [IP-12. "Steering Column Cover"](#).
2. While pressing tabs, pull lighting and turn signal switch toward driver door and disconnect from the base.

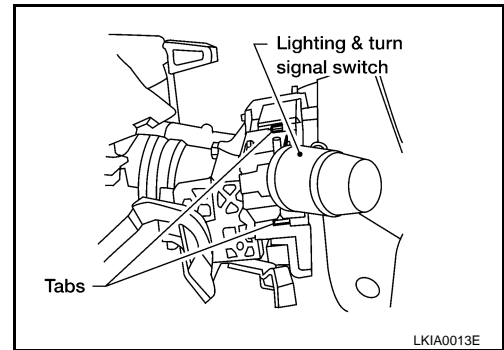

Installation

INFOID:000000001719123

Installation is in the reverse order of removal.

A
B
C
D
E
F
G
H
I
J
LT
L
M
N
O
P

HAZARD SWITCH

< SERVICE INFORMATION >

HAZARD SWITCH

Removal and Installation

INFOID:000000001719124

Removal

1. Remove cluster lid C. Refer to [IP-13. "Cluster Lid C"](#).
2. Press tabs and remove hazard switch (1).

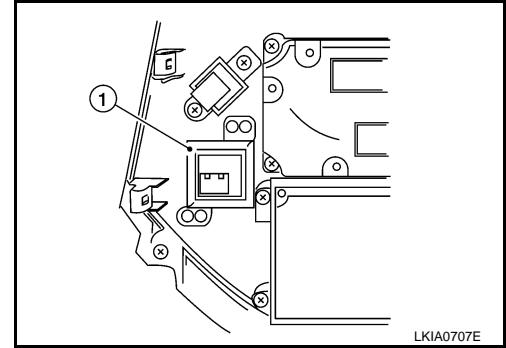

Installation

Installation is in the reverse order of removal.

COMBINATION SWITCH

< SERVICE INFORMATION >

COMBINATION SWITCH

Wiring Diagram - COMBSW -

INFOID:000000001719125

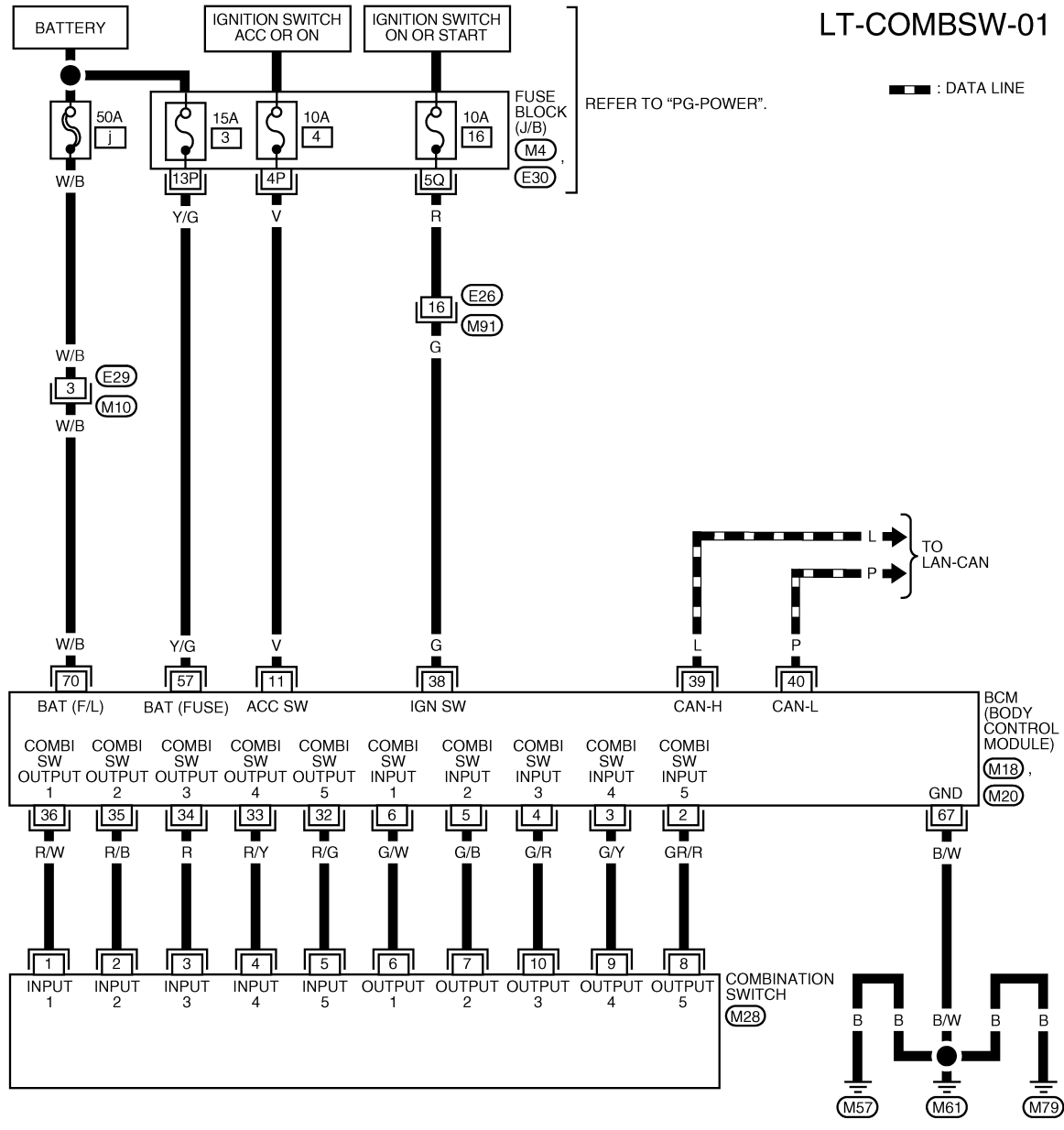

Combination Switch Reading Function

For details, refer to [BCS-3, "System Description"](#).

INFOID:000000001719126

A
B
C
D
E
F
G
H
I
J
LT
L
M
N
O
P

COMBINATION SWITCH

< SERVICE INFORMATION >

CONSULT-III Function (BCM)

INFOID:000000001719127

CONSULT-III can display each diagnostic item using the diagnostic test modes shown following.

BCM diagnostic test item	Diagnostic mode	Description
Inspection by part	WORK SUPPORT	Supports inspections and adjustments. Commands are transmitted to the BCM for setting the status suitable for required operation, input/output signals are received from the BCM and received data is displayed.
	DATA MONITOR	Displays BCM input/output data in real time.
	ACTIVE TEST	Operation of electrical loads can be checked by sending drive signal to them.
	SELF-DIAG RESULTS	Displays BCM self-diagnosis results.
	CAN DIAG SUPPORT MNTR	The result of transmit/receive diagnosis of CAN communication can be read.
	ECU PART NUMBER	BCM part number can be read.
	CONFIGURATION	Performs BCM configuration read/write functions.

DATA MONITOR

Operation Procedure

1. Touch "COMB SW" on "SELECT TEST ITEM" screen.
2. Touch "DATA MONITOR" on "SELECT DIAG MODE" screen.
3. Touch either "ALL SIGNALS" or "SELECTION FROM MENU" on "SELECT MONITOR ITEM" screen.

ALL SIGNALS	Monitors all the signals.
SELECTION FROM MENU	Selects and monitors individual signal.

4. Touch "START".
5. When "SELECTION FROM MENU" is selected, touch items to be monitored. When "ALL SIGNALS" is selected, all the signals will be monitored.
6. Touch "RECORD" while monitoring, then the status of the monitored item can be recorded. To stop recording, touch "STOP".

Display Item List

Monitor item name "OPERATION OR UNIT"	Contents
TURN SIGNAL R "ON/OFF"	Displays "Turn Right (ON)/Other (OFF)" status, determined from lighting switch signal.
TURN SIGNAL L "ON/OFF"	Displays "Turn Left (ON)/Other (OFF)" status, determined from lighting switch signal.
HI BEAM SW "ON/OFF"	Displays status (high beam switch: ON/Others: OFF) of high beam switch judged from lighting switch signal.
HEAD LAMP SW 1 "ON/OFF"	Displays "Headlamp switch 1 (ON)/Other (OFF)" status, determined from lighting switch signal.
HEAD LAMP SW 2 "ON/OFF"	Displays status (headlamp switch 2: ON/Others: OFF) of headlamp switch 2 judged from lighting switch signal.
LIGHT SW 1ST "ON/OFF"	Displays status (lighting switch 1st position: ON/Others: OFF) of lighting switch judged from lighting switch signal.
PASSING SW "ON/OFF"	Displays status (flash-to-pass switch: ON/Others: OFF) of flash-to-pass switch judged from lighting switch signal.
AUTO LIGHT SW "ON/OFF"	Displays "Auto light switch (ON)/Other (OFF)" status, determined from lighting switch signal.
FR FOG SW "ON/OFF"	Displays "Front fog lamp switch (ON)/Other (OFF)" status, determined from lighting switch signal.
FR WIPER HI "ON/OFF"	Displays "Front Wiper HI (ON)/Other (OFF)" status, determined from wiper switch signal.
FR WIPER LOW "ON/OFF"	Displays "Front Wiper LOW (ON)/Other (OFF)" status, determined from wiper switch signal.
FR WIPER INT "ON/OFF"	Displays "Front Wiper INT (ON)/Other (OFF)" status, determined from wiper switch signal.
FR WASHER SW "ON/OFF"	Displays "Front Washer Switch (ON)/Other (OFF)" status, determined from wiper switch signal.
INT VOLUME [1 - 7]	Displays intermittent operation knob setting (1 - 7), determined from wiper switch signal.

COMBINATION SWITCH

< SERVICE INFORMATION >

Monitor item name "OPERATION OR UNIT"	Contents
RR WIPER ON "ON/OFF"	Displays "Rear Wiper (ON)/(OFF)" status, determined from wiper switch signal.
RR WIPER INT "ON/OFF"	Displays "Rear Wiper INT (ON)/(OFF)" status, determined from wiper switch signal.
RR WASHER SW "ON/OFF"	Displays "Rear Washer (ON)/(OFF)" status, determined from wiper switch signal.

Combination Switch Inspection

INFOID:000000001719128

1.SYSTEM CHECK

1. Referring to table below, check to which system the malfunctioning switch belongs.

System 1	System 2	System 3	System 4	System 5
—	FR WASHER	FR WIPER LO	TURN LH	TURN RH
FR WIPER HI	—	FR WIPER INT	PASSING	HEAD LAMP1
INT VOLUME 1	RR WASHER	—	HEAD LAMP2	HI BEAM
RR WIPER INT	INT VOLUME 3	AUTO LIGHT	—	TAIL LAMP
INT VOLUME 2	RR WIPER ON	—	FR FOG	—

>> GO TO 2.

2.SYSTEM CHECK

 With CONSULT-III

1. Connect CONSULT-III, and select "COMB SW" on "SELECT TEST ITEM" screen.
2. Select "DATA MONITOR".
3. Select "START" and confirm that other switches in malfunctioning system operate normally.
Example: When auto light switch is malfunctioning, confirm that "FRONT WIPER LOW" and "FRONT WIPER INT" in System 3, to which the auto light switch belongs, turn ON-OFF normally.

 Without CONSULT-III

Operate combination switch and confirm that other switches in malfunctioning system operate normally.
Example: When auto light switch is malfunctioning, confirm that "FRONT WIPER LOW" and "FRONT WIPER INT" in System 3, to which the auto light switch belongs, operate normally.

Check results

- Other switches in malfunctioning system operate normally.>>Replace lighting switch or wiper switch.
- Other switches in malfunctioning system do not operate normally.>>GO TO 3.

3.HARNES INSPECTION

1. Turn ignition switch OFF.
2. Disconnect BCM and combination switch connectors.
3. Check for continuity between BCM harness connector of the suspect system and the corresponding combination switch connector terminals.

COMBINATION SWITCH

< SERVICE INFORMATION >

Suspect system	BCM		Combination switch		Continuity
	Connector	Terminal	Connector	Terminal	
1	M18	Input 1	6	M28	6
		Output 1	36		1
2		Input 2	5		7
		Output 2	35		2
3		Input 3	4		10
		Output 3	34		3
4		Input 4	3		9
		Output 4	33		4
5		Input 5	2		8
		Output 5	32		5

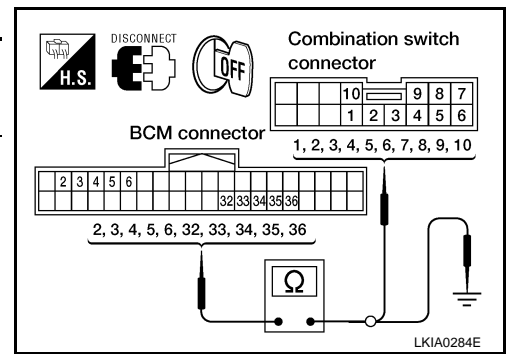

4. Check for continuity between each terminal of BCM harness connector in suspect malfunctioning system and ground.

Suspect system	BCM		Continuity
	Connector	Terminal	
1	M18	Input 1	6
		Output 1	36
2		Input 2	5
		Output 2	35
3		Input 3	4
		Output 3	34
4		Input 4	3
		Output 4	33
5		Input 5	2
		Output 5	32

OK or NG

OK >> GO TO 4.

NG >> Check harness between BCM and combination switch for open or short circuit.

4. BCM OUTPUT TERMINAL INSPECTION

1. Turn lighting switch and wiper switch to OFF.
2. Set wiper dial to position 4.
3. Connect BCM and combination switch connectors.

COMBINATION SWITCH

< SERVICE INFORMATION >

4. Turn ignition switch ON, and check combination switch input (BCM output) terminal voltage waveform of suspect malfunctioning system.

Suspect system	Combination switch		
	(+)		
	Connector	Terminal	
1	M28	Input 1	1
2		Input 2	2
3		Input 3	3
4		Input 4	4
5		Input 5	5

OK or NG

- OK >> Open circuit in combination switch, GO TO 5.
 NG >> Replace BCM. Refer to [BCS-18, "Removal and Installation of BCM"](#).

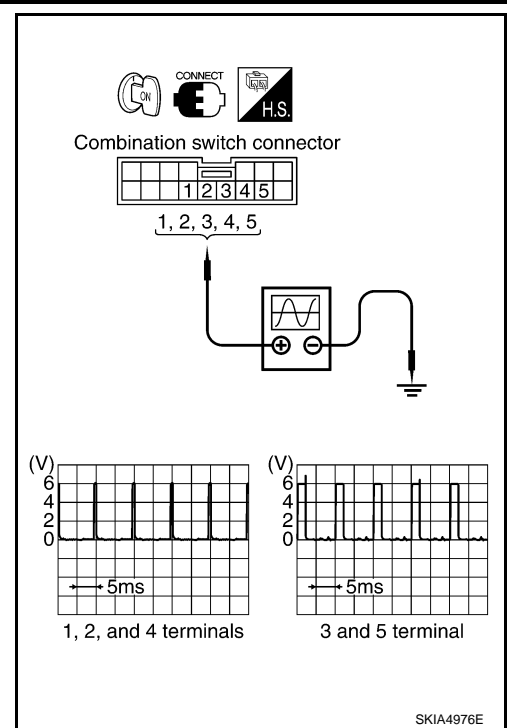

5.COMBINATION SWITCH INSPECTION

Referring to table below, perform combination switch inspection.

Procedure									
1	2		3	4		5	6		7
Replace lighting switch.	Confirm check results.	OK	INSPECTION END	Confirm check results.	OK	INSPECTION END	Confirm check results.	OK	INSPECTION END
		NG	Replace wiper switch.		NG	Replace switch base.		NG	Confirm symptom again.

>> Inspection End.

Removal and Installation

INFOID:000000001719129

Refer to [LT-77, "Removal"](#).

Switch Circuit Inspection

INFOID:000000001719130

Refer to [LT-81, "Combination Switch Inspection"](#).

STOP LAMP

< SERVICE INFORMATION >

STOP LAMP

System Description

INFOID:000000001719131

Power is supplied at all times

- through 10A fuse [No. 20, located in fuse block (J/B)]
- to stop lamp switch terminal 1.

When the brake pedal is pressed, the stop lamp switch is closed and power is supplied

- through stop lamp switch terminal 2
- to rear combination lamp LH and RH terminal 1, and
- to high-mounted stop lamp terminal +.

Ground is supplied

- to rear combination lamp LH terminal 5
- through grounds B7 and B19, and
- to rear combination lamp RH terminal 5
- through grounds B117 and B132, and
- to high-mounted stop lamp terminal –
- through grounds D403 and D404.

With power and ground supplied, the stop lamps illuminate.

STOP LAMP

< SERVICE INFORMATION >

Wiring Diagram - STOP/L -

INFOID:000000001719132

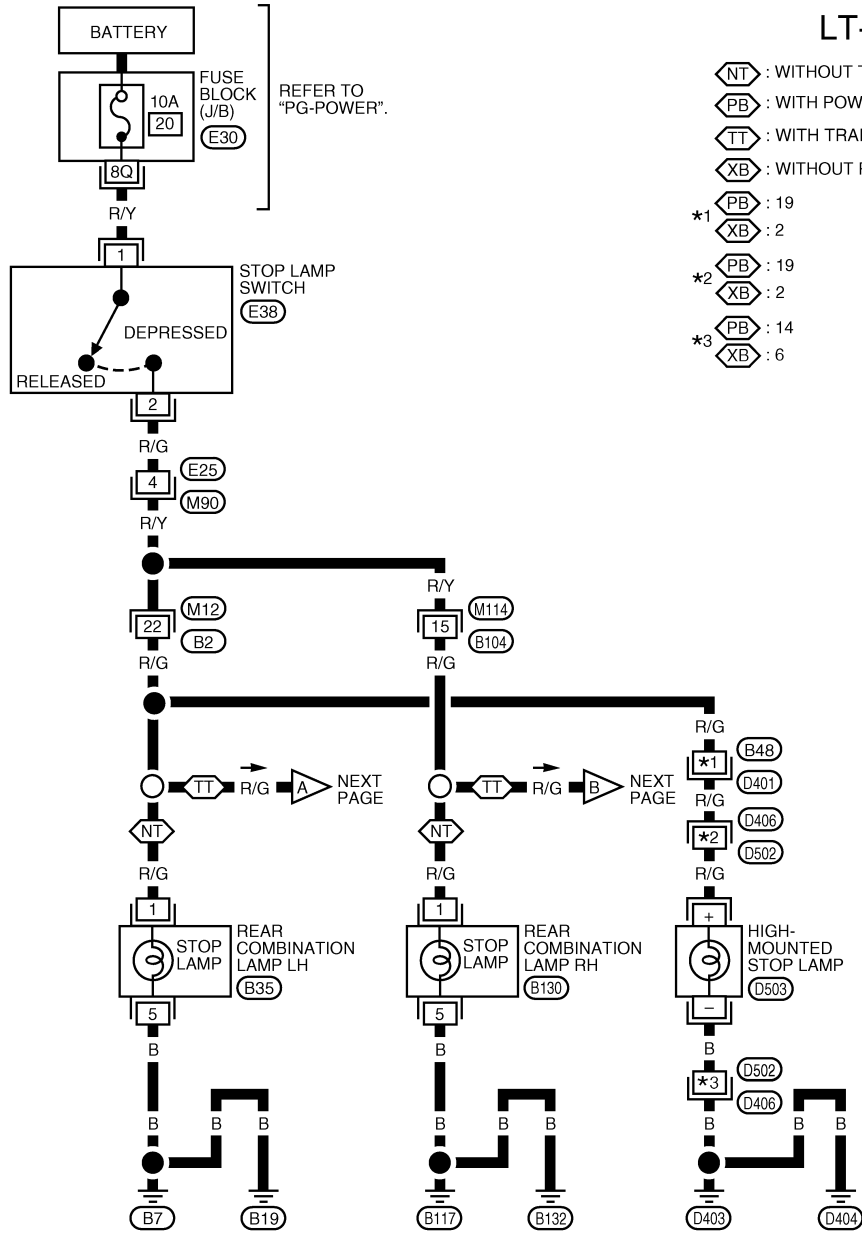

LT-STOP/L-01

- ◊NT : WITHOUT TRAILER TOW
- ◊PB : WITH POWER BACK DOOR
- ◊TT : WITH TRAILER TOW
- ◊XB : WITHOUT POWER BACK DOOR
- *1 ◊PB : 19
◊XB : 2
- *2 ◊PB : 19
◊XB : 2
- *3 ◊PB : 14
◊XB : 6

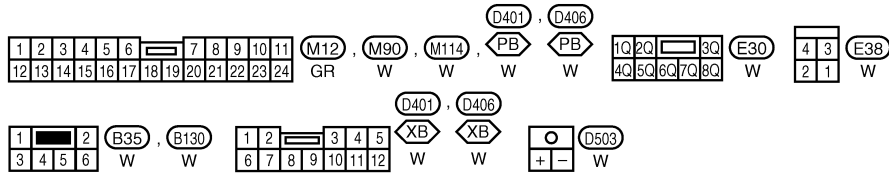

WKWA4704E

STOP LAMP

< SERVICE INFORMATION >

LT-STOP/L-02

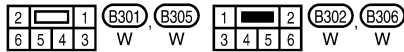
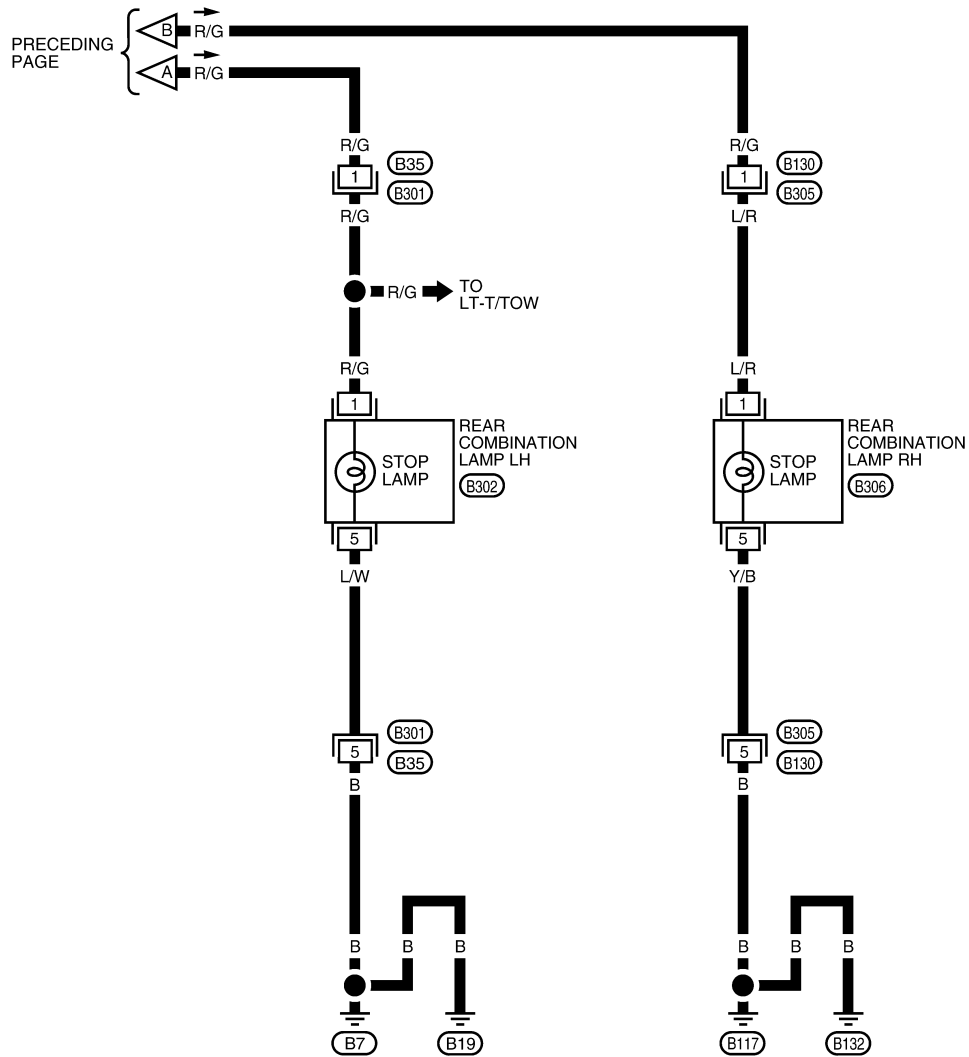

Bulb Replacement

HIGH-MOUNTED STOP LAMP

Removal

WKWA4705E

INFOID:000000001719133

STOP LAMP

< SERVICE INFORMATION >

1. Remove the rear washer nozzle. Refer to [WW-35. "Rear Washer Nozzle"](#).
2. Disconnect the electrical connector.
3. Remove the nuts and remove the high-mounted stop lamp.
4. Turn the bulb socket counterclockwise to remove it from the high-mounted stop lamp housing.
5. Pull the bulb from the socket.

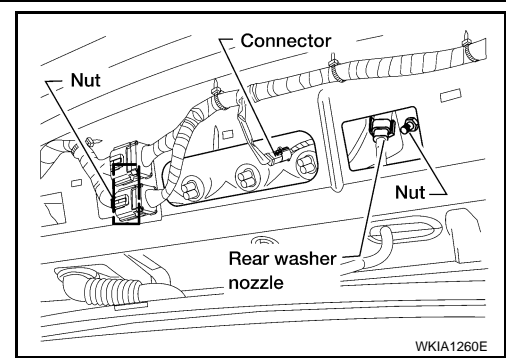

Installation

Installation is in the reverse order of removal.

STOP LAMP

Refer to [LT-102. "Bulb Replacement"](#).

Removal and Installation

INFOID:000000001719134

HIGH-MOUNTED STOP LAMP

Removal

1. Remove the rear washer nozzle. Refer to [WW-35. "Rear Washer Nozzle"](#).
2. Disconnect the electrical connector.
3. Remove the nuts and remove the high-mounted stop lamp.

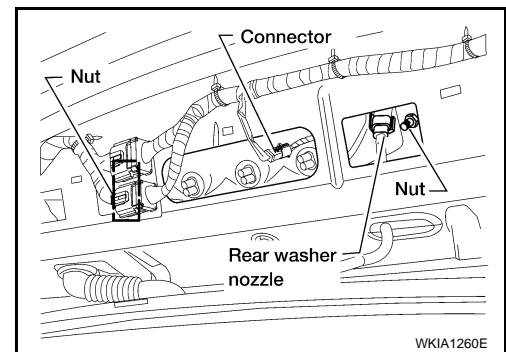

Installation

Installation is in the reverse order of removal.

STOP LAMP

Refer to [LT-102. "Removal and Installation"](#).

A
B
C
D
E
F
G
H
I
J
LT
L
M
N
O
P

BACK-UP LAMP

< SERVICE INFORMATION >

BACK-UP LAMP

Wiring Diagram - BACK/L -

INFOID:000000001719135

LT-BACK/L-01

⬡NT : WITHOUT TRAILER TOW
 ⬡TT : WITH TRAILER TOW

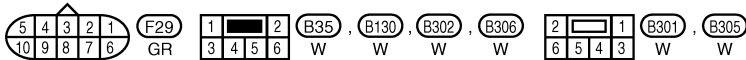
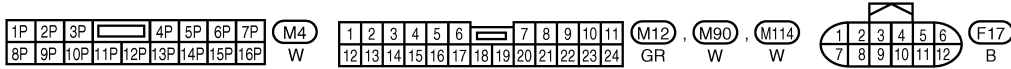
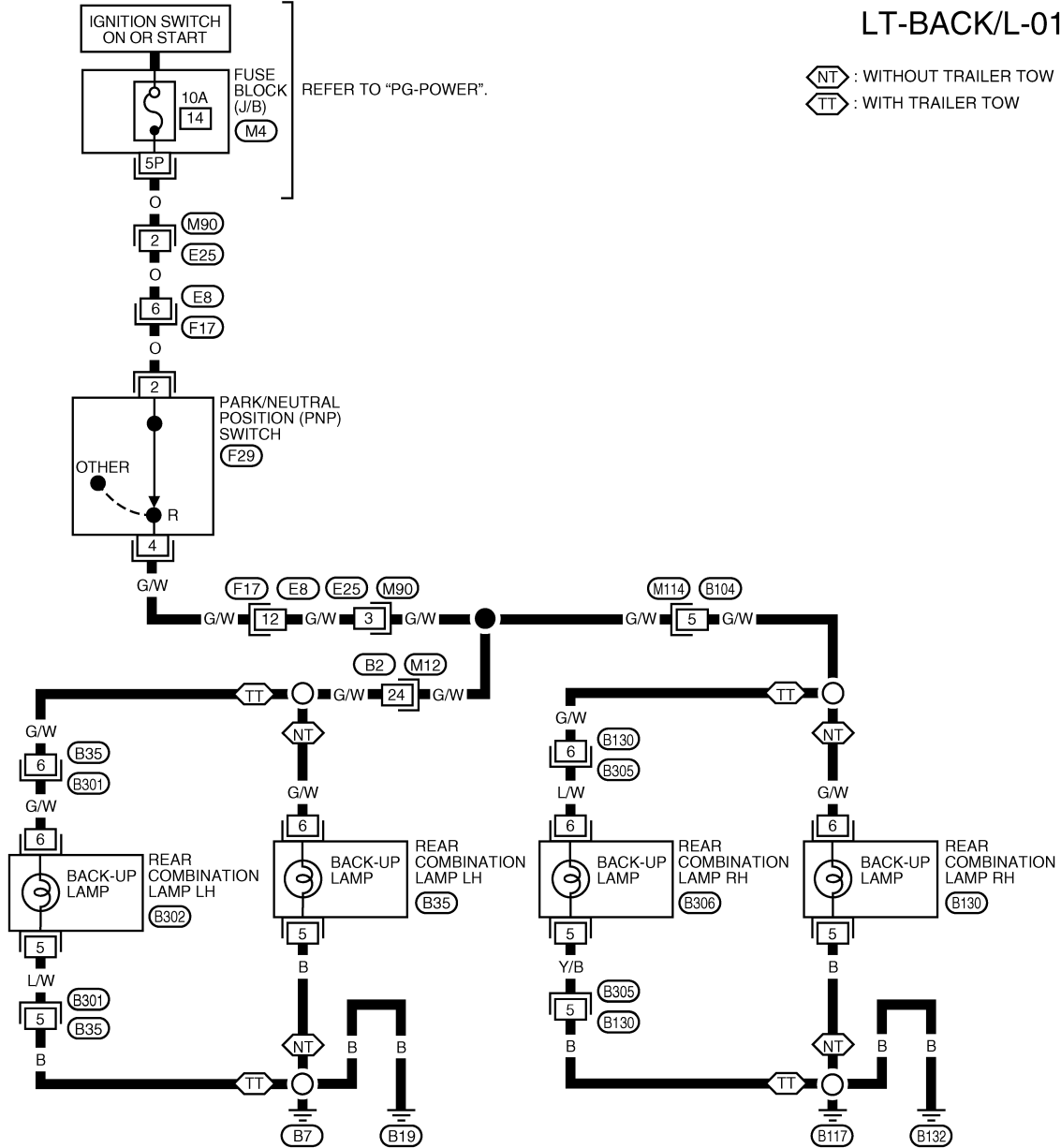

WKWA4706E

Bulb Replacement

Refer to [LT-102, "Bulb Replacement"](#).

INFOID:000000001719136

BACK-UP LAMP

< SERVICE INFORMATION >

Removal and Installation

INFOID:000000001719137

Refer to [LT-102. "Removal and Installation"](#).

- A
- B
- C
- D
- E
- F
- G
- H
- I
- J
- LT**
- L
- M
- N
- O
- P

PARKING, LICENSE PLATE AND TAIL LAMPS

< SERVICE INFORMATION >

PARKING, LICENSE PLATE AND TAIL LAMPS

Component Parts and Harness Connector Location

INFOID:000000001719138

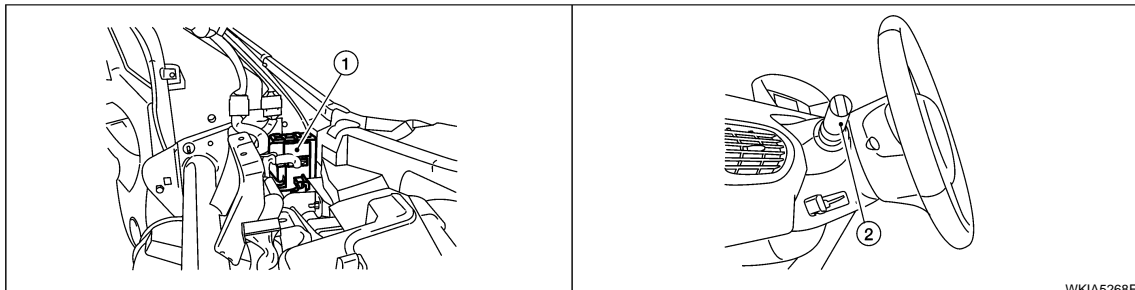

1. BCM M18, M20 (view with instrument panel removed)
2. Combination switch (lighting switch) M28

System Description

INFOID:000000001719139

Control of the parking, license plate, and tail lamp operation is dependent upon the position of the lighting switch (combination switch). When the lighting switch is placed in the 1ST position, the BCM (body control module) receives input signal requesting the parking, license plate and tail lamps to illuminate. This input signal is communicated to the IPDM E/R (intelligent power distribution module engine room) across the CAN communication lines. The CPU (central processing unit) of the IPDM E/R controls the tail lamp relay coil. This relay, when energized, directs power to the parking, license plate and tail lamps, which then illuminate.

Power is supplied at all times

- to ignition relay, located in the IPDM E/R, and
- through 15A fuse (No. 41, located in the IPDM E/R)
- to tail lamp relay, located in the IPDM E/R, and
- to CPU of the IPDM E/R, and
- through 15A fuse (No. 34 located in the IPDM E/R)
- to CPU of the IPDM E/R, and
- through 50A fusible link (letter j, located in the fuse and fusible link box)
- to BCM terminal 70, and
- through 15A fuse [No. 3, located in the fuse block (J/B)]
- to BCM terminal 57.

With the ignition switch in the ON or START position, power is supplied

- to ignition relay, located in the IPDM E/R, and
- through 10A fuse [No. 16, located in the fuse block (J/B)]
- to BCM terminal 38.

With the ignition switch in the ACC or ON position, power is supplied

- through 10A fuse [No. 4, located in the fuse block (J/B)]
- to BCM terminal 11.

Ground is supplied

- to BCM terminal 67
- through grounds M57, M61 and M79, and
- to IPDM E/R terminals 38 and 60
- through grounds E9, E15 and E24.

OPERATION BY LIGHTING SWITCH

With the lighting switch in the 1ST or 2ND position (or if the auto light system is activated), the BCM receives input signal requesting the parking, license plate and tail lamps to illuminate. This input signal is communicated to the IPDM E/R across the CAN communication lines. The CPU in the IPDM E/R controls the tail lamp relay coil, which when energized, directs power

- through IPDM E/R terminal 22
- to front combination lamp LH and RH terminal 5
- to license plate lamp LH and RH terminal +
- to rear combination lamp LH and RH terminal 2.

Ground is supplied

PARKING, LICENSE PLATE AND TAIL LAMPS

< SERVICE INFORMATION >

- to front combination lamp LH and RH terminal 6
- through grounds E9, E15 and E24, and
- to license plate lamp LH and RH terminal –
- through grounds D403 and D404, and
- to rear combination lamp LH terminal 5
- through grounds B7 and B19, and
- to rear combination lamp RH terminal 5
- through grounds B117 and B132.

With power and ground supplied, the parking, license plate and tail lamps illuminate.

COMBINATION SWITCH READING FUNCTION

Refer to [BCS-3. "System Description"](#).

EXTERIOR LAMP BATTERY SAVER CONTROL

When the combination switch (lighting switch) is in the 1ST (or 2ND) position and the ignition switch is turned from ON or ACC to OFF, the battery saver control feature is activated.

Under this condition, the parking, license and tail lamps remain illuminated for 5 minutes, then the parking, license plate and tail lamps are turned off.

Exterior lamp battery saver control mode can be changed by the function setting of CONSULT-III.

CAN Communication System Description

INFOID:000000001719140

Refer to [LAN-3. "CAN Communication System"](#).

A
B
C
D
E
F
G
H
I
J
L
M
N
O
P

LT

PARKING, LICENSE PLATE AND TAIL LAMPS

< SERVICE INFORMATION >

Wiring Diagram - TAIL/L -

INFOID:000000001719142

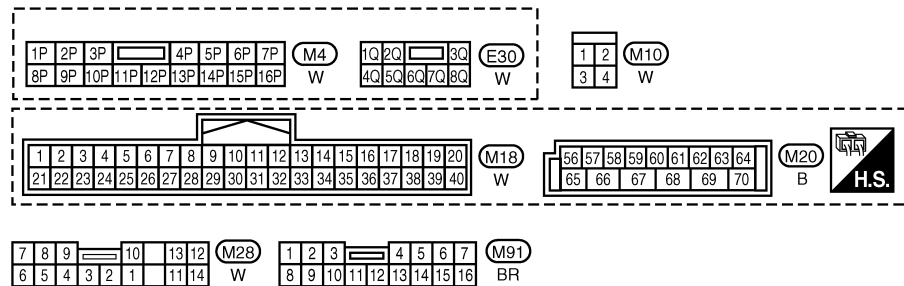
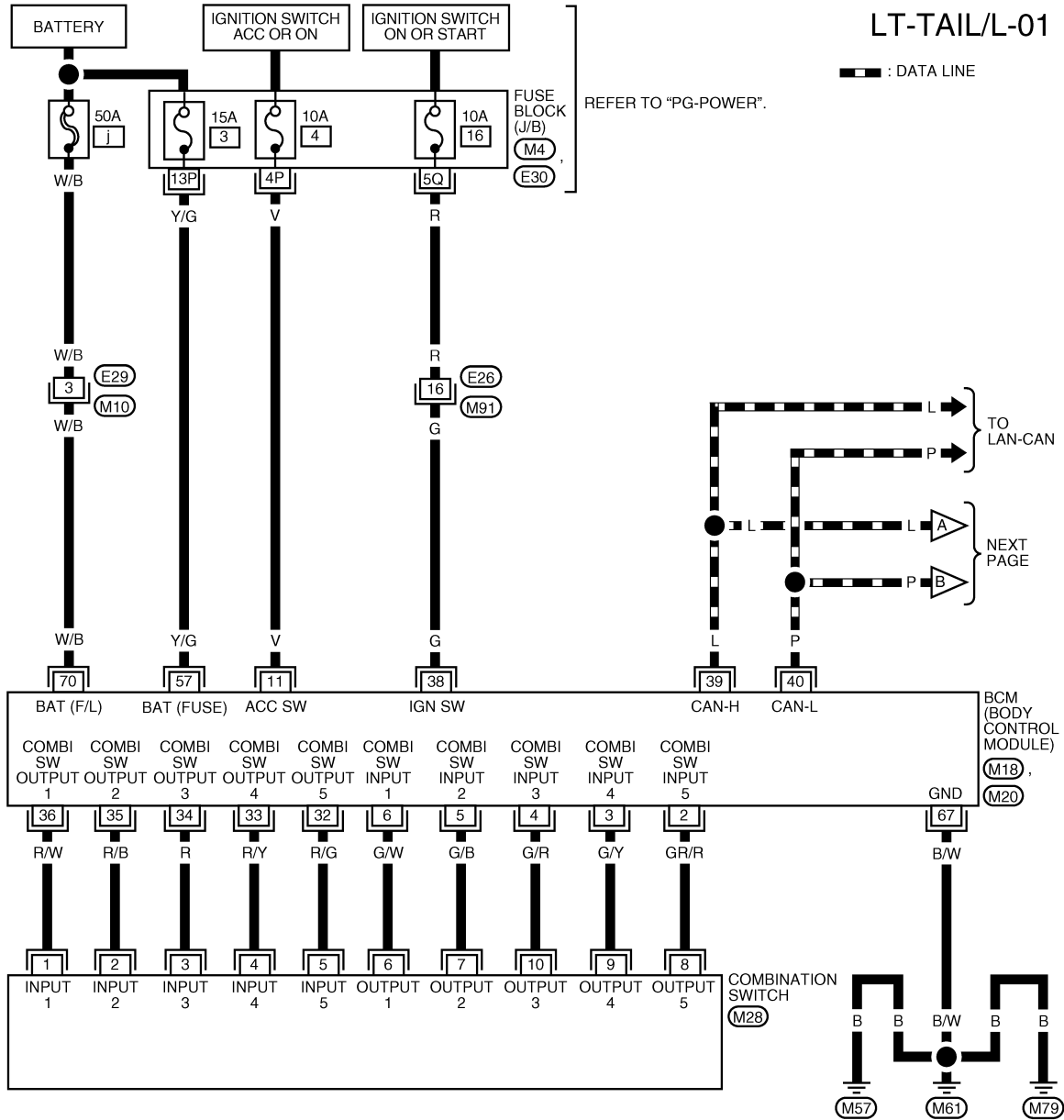

WKWA4708E

PARKING, LICENSE PLATE AND TAIL LAMPS

< SERVICE INFORMATION >

▬ : DATA LINE

LT-TAIL/L-02

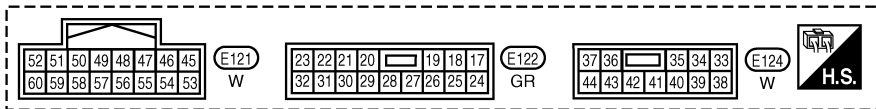
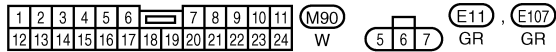
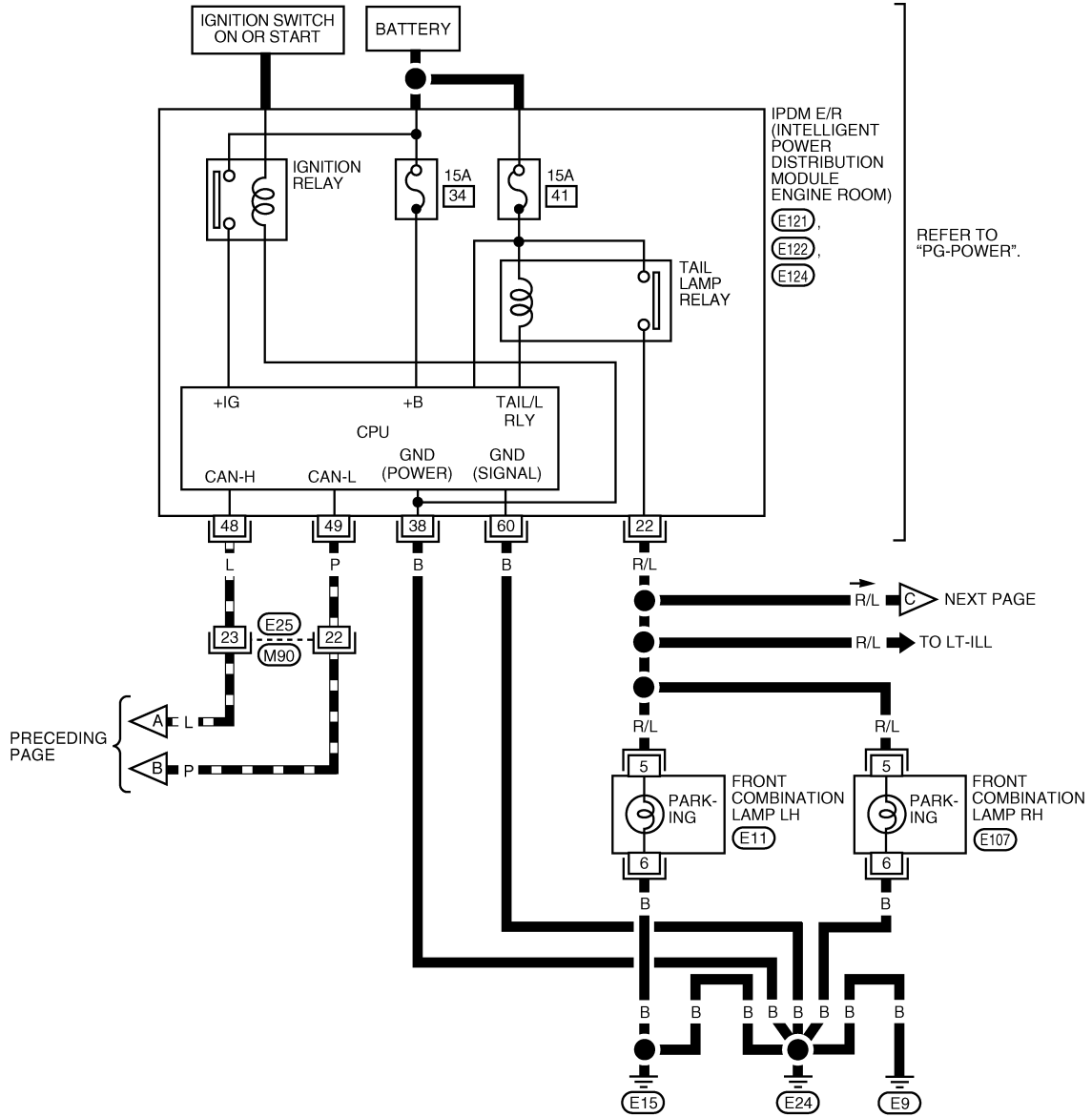

WKWA4709E

PARKING, LICENSE PLATE AND TAIL LAMPS

< SERVICE INFORMATION >

LT-TAIL/L-04

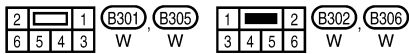
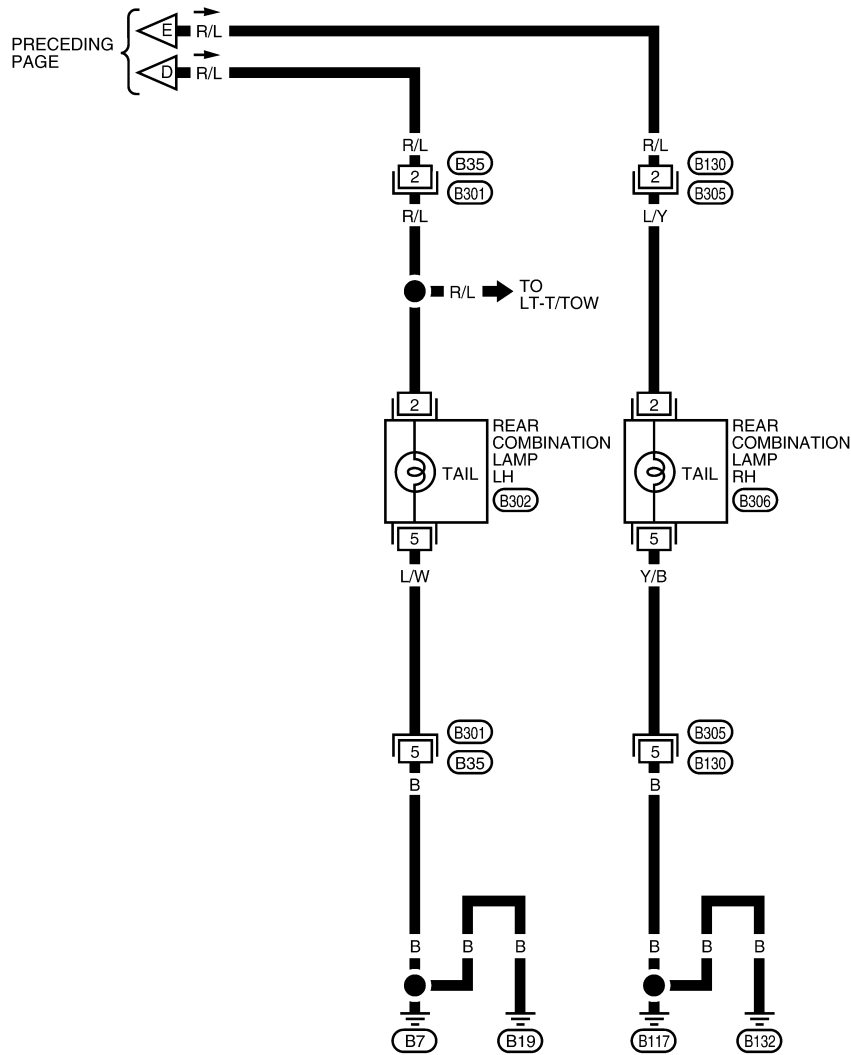

WKWA4711E

INFOID:000000001719143

Terminal and Reference Value for BCM

Refer to [BCS-11, "Terminal and Reference Value for BCM"](#).

Terminal and Reference Value for IPDM E/R

INFOID:000000001719144

Refer to [PG-24, "Terminal and Reference Value for IPDM E/R"](#).

PARKING, LICENSE PLATE AND TAIL LAMPS

< SERVICE INFORMATION >

How to Proceed with Trouble Diagnosis

INFOID:000000001719145

1. Confirm the symptom or customer complaint.
2. Understand operation description and function description. Refer to [LT-90, "System Description"](#).
3. Carry out the Preliminary Check. Refer to [LT-97, "Preliminary Check"](#).
4. Check symptom and repair or replace the cause of malfunction.
5. Do the parking, license and tail lamps operate normally? If YES: GO TO 6. If NO: GO TO 4.
6. Inspection End.

Preliminary Check

INFOID:000000001719146

CHECK POWER SUPPLY AND GROUND CIRCUIT

Refer to [BCS-15, "BCM Power Supply and Ground Circuit Inspection"](#) and [PG-27, "IPDM E/R Power/Ground Circuit Inspection"](#).

CONSULT-III Functions

INFOID:000000001719147

Refer to [LT-12, "CONSULT-III Function \(BCM\)"](#) in HEADLAMP (FOR USA).
Refer to [LT-14, "CONSULT-III Function \(IPDM E/R\)"](#) in HEADLAMP (FOR USA).

Parking, License Plate and/or Tail Lamps Do Not Illuminate

INFOID:000000001719148

1.CHECK COMBINATION SWITCH INPUT SIGNAL

With CONSULT-III

Select "BCM" on CONSULT-III. With "HEAD LAMP" data monitor, make sure "LIGHT SW 1ST" turns ON-OFF linked with operation of lighting switch.

When lighting switch is in 1ST position : LIGHT SW 1ST ON

Without CONSULT-III

Refer to [LT-81, "Combination Switch Inspection"](#).

OK or NG

OK >> GO TO 2.

NG >> Check lighting switch. Refer to [LT-81, "Combination Switch Inspection"](#).

2.ACTIVE TEST

With CONSULT-III

1. Select "IPDM E/R" on CONSULT-III, and select "ACTIVE TEST" on "SELECT DIAG MODE" screen.
2. Select "TAIL LAMP" on "SELECT TEST ITEM" screen.
3. Touch "ON" on "ACTIVE TEST" screen.
4. Make sure parking, license plate and tail lamp operation.

Parking, license plate and tail lamp should operate

Without CONSULT-III

1. Start auto active test. Refer to [PG-20, "Auto Active Test"](#).
2. Make sure parking, license plate and tail lamp operation.

Parking, license plate and tail lamp should operate

OK or NG

OK >> GO TO 3.

NG >> GO TO 4.

3.CHECK IPDM E/R

1. Select "IPDM E/R" on CONSULT-III, and select "DATA MONITOR" on "SELECT DIAG MODE" screen.
2. Make sure "TAIL&CLR REQ" turns ON when lighting switch is in 1ST position.

PARKING, LICENSE PLATE AND TAIL LAMPS

< SERVICE INFORMATION >

When lighting switch is in 1ST position : TAIL&CLR REQ ON

OK or NG

- OK >> Replace IPDM E/R. Refer to [PG-28. "Removal and Installation of IPDM E/R"](#).
- NG >> Replace BCM. Refer to [BCS-18. "Removal and Installation of BCM"](#).

4. CHECK INPUT SIGNAL

Ⓚ With CONSULT-III

1. Turn ignition switch OFF.
2. Disconnect front combination lamp, license plate lamp and rear combination lamp connectors.
3. Turn ignition switch ON.
4. Select "IPDM E/R" on CONSULT-III, and select "ACTIVE TEST" on "SELECT DIAG MODE" screen.
5. Select "TAIL LAMP" on "SELECT TEST ITEM" screen.
6. Touch "ON" on "ACTIVE TEST" screen.
7. When tail lamp is operating, check voltage between front combination lamp, license plate lamp, rear combination lamp harness connector and ground.

Ⓧ Without CONSULT-III

1. Start auto active test. Refer to [PG-20. "Auto Active Test"](#).
2. When tail lamp is operating, check voltage between front combination lamp, license plate lamp, rear combination lamp harness connector and ground.

Terminals		Terminal	(-)	Voltage
(+)				
Front combination lamp connector		4	Ground	Battery voltage
RH	E107			
LH	E11			

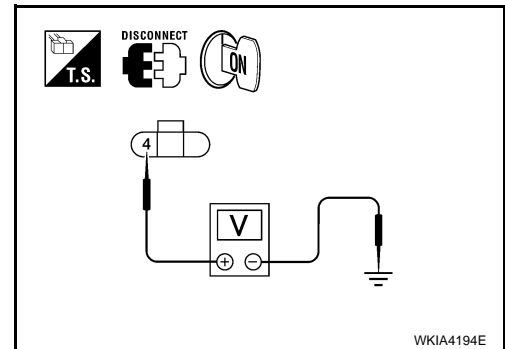

License plate lamp		Terminal	(-)	Voltage
(+)				
Connector		+	Ground	Battery voltage
RH	D508			
LH	D509			

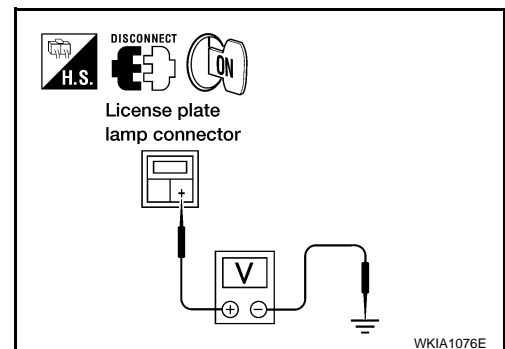

Rear combination lamp		Terminal	(-)	Voltage
(+)				
Connector		2	Ground	Battery voltage
RH	B130 (without trailer tow) B306 (with trailer tow)			
LH	B35 (without trailer tow) B302 (with trailer tow)			

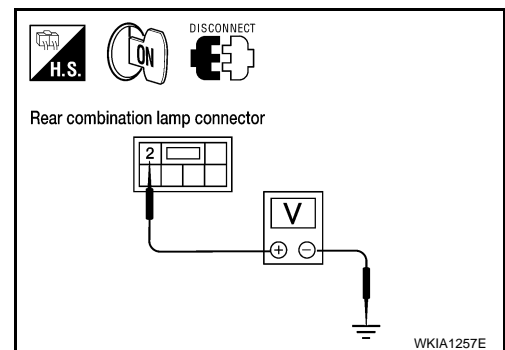

OK or NG

- OK >> GO TO 6.
- NG >> GO TO 5.

PARKING, LICENSE PLATE AND TAIL LAMPS

< SERVICE INFORMATION >

5. CHECK PARKING, LICENSE PLATE AND TAIL LAMP CIRCUIT

1. Turn ignition switch OFF.
2. Disconnect IPDM E/R connector.
3. Check continuity between IPDM E/R harness connector and front combination lamp harness connector.

A		B		Continuity	
IPDM E/R connector	Terminal	Front combination lamp connector			
E122	22	RH	E107	4	Yes
		LH	E11		

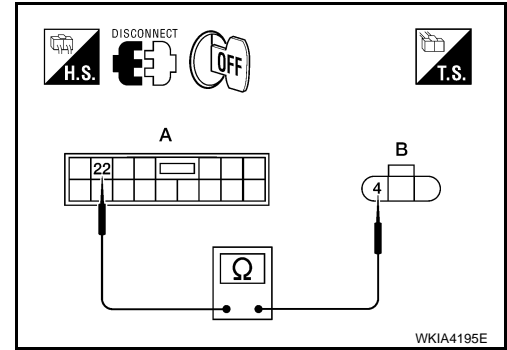

4. Check continuity between IPDM E/R harness connector and license plate lamp harness connector.

IPDM E/R		License plate lamp		Continuity	
Connector	Terminal	Connector	Terminal		
E122	22	RH	D508	+	Yes
		LH	D509		

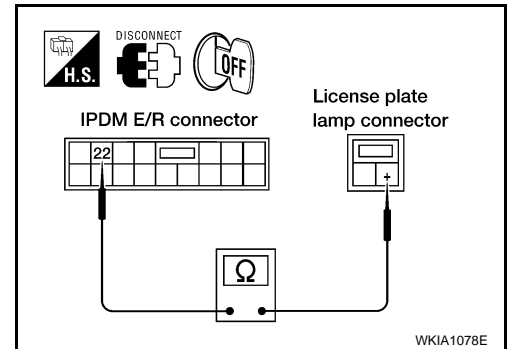

5. Check continuity between IPDM E/R harness connector and rear combination lamp harness connector.

IPDM E/R		Rear combination lamp			Continuity	
Connector	Terminal	Connector		Terminal		
E122	22	RH	B130 (without trailer tow) B306 (with trailer tow)		2	Yes
		LH	B35 (without trailer tow) B302 (with trailer tow)			

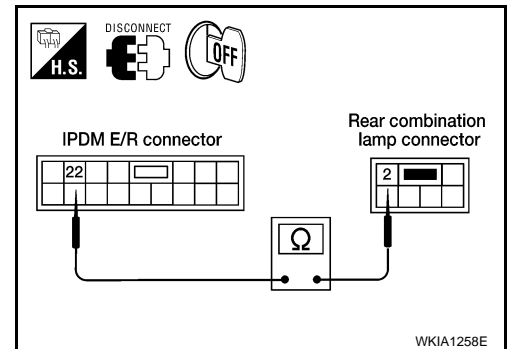

OK or NG

- OK >> Replace IPDM E/R. Refer to [PG-28, "Removal and Installation of IPDM E/R"](#).
- NG >> Repair harness or connector.

6. CHECK GROUND

1. Turn ignition switch OFF.
2. Check continuity between front combination lamp harness connector and ground.

Front combination lamp connector		Terminal	Ground	Continuity
RH	E107	5		
LH	E11			

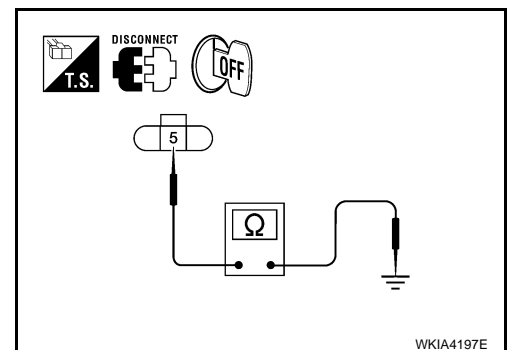

PARKING, LICENSE PLATE AND TAIL LAMPS

< SERVICE INFORMATION >

- Check continuity between license lamp plate harness connector and ground.

License plate lamp		Terminal	Ground	Continuity
Connector				
RH	D508	-	Ground	Yes
LH	D509			

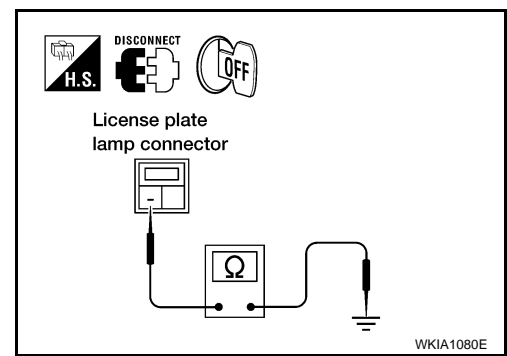

- Check continuity between rear combination lamp harness connector and ground.

Rear combination lamp		Terminal	Ground	Continuity
Connector				
RH	B130 (without trailer tow) B306 (with trailer tow)	5	Ground	Yes
LH	B35 (without trailer tow) B302 (with trailer tow)			

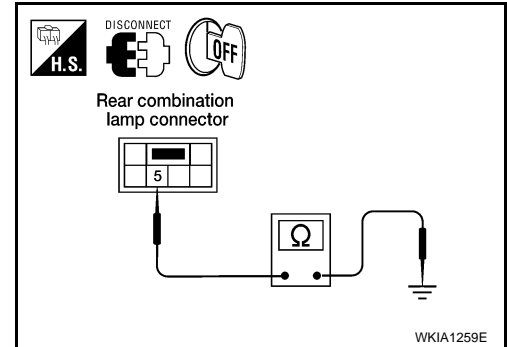

OK or NG

- OK >> Check bulbs.
- NG >> Repair harness or connector.

Parking, License Plate and Tail Lamps Do Not Turn OFF (After Approx. 10 Minutes)

INFOID:000000001719149

1. CHECK IPDM E/R

- Turn ignition switch ON. Turn the combination switch (lighting switch) to the OFF position. Turn ignition switch OFF.
- Verify that the parking, license plate, and tail lamps turn on and off after approximately 10 minutes.

OK or NG

- OK >> Ignition relay malfunction. Refer to [PG-18, "Function of Detecting Ignition Relay Malfunction"](#).
- NG >> Inspection End.

Bulb Replacement

INFOID:000000001719150

FRONT PARKING LAMP

Refer to [LT-22, "Bulb Replacement"](#).

LICENSE PLATE LAMP

Removal

- Remove back door lower finisher. Refer to [EI-31, "Removal and Installation"](#).
- Remove license plate lamp socket.
- Remove license plate lamp.

Installation

Installation is in the reverse order of removal.

TAIL LAMP

Refer to [LT-102, "Bulb Replacement"](#).

Removal and Installation

INFOID:000000001719151

FRONT PARKING LAMP

Refer to [LT-23, "Removal and Installation"](#).

PARKING, LICENSE PLATE AND TAIL LAMPS

< SERVICE INFORMATION >

LICENSE PLATE LAMP

Removal

1. Remove license plate finisher. Refer to [EI-23](#).
2. Remove license plate lamp.

Installation

Installation is in the reverse order of removal.

TAIL LAMP

Refer to [LT-102. "Removal and Installation"](#).

A

B

C

D

E

F

G

H

I

J

LT

L

M

N

O

P

REAR COMBINATION LAMP

< SERVICE INFORMATION >

REAR COMBINATION LAMP

Bulb Replacement

INFOID:000000001719152

REMOVAL

1. Remove rear lower finisher assembly. Refer to [EI-31. "Removal and Installation"](#).
2. Turn rear combination lamp socket counterclockwise and remove from rear combination lamp.
3. Remove bulb from rear combination lamp socket..

INSTALLATION

Installation is in the reverse order of removal.

Removal and Installation

INFOID:000000001719153

REMOVAL

1. Remove rear lower finisher assembly. Refer to [EI-31. "Removal and Installation"](#).
2. Turn rear combination lamp socket counterclockwise and remove rear combination lamp.
3. Remove rear combination lamp bolts.
4. Pull rear combination lamp to remove from vehicle.

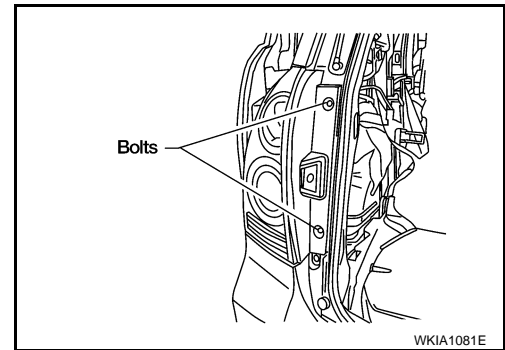

INSTALLATION

Installation is in the reverse order of removal.

NOTE:

- Install rear combination lamp harness and grommet so that paint mark on grommet is at top and harness points down.

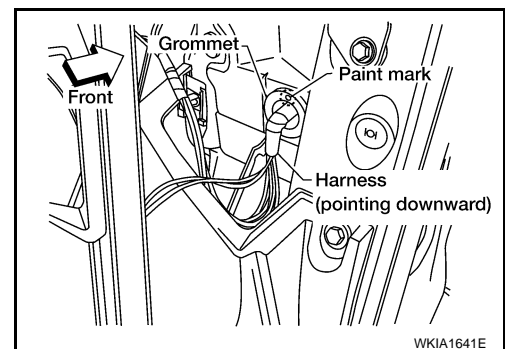

TRAILER TOW

< SERVICE INFORMATION >

TRAILER TOW

Component Parts and Harness Connector Location

INFOID:000000001719154

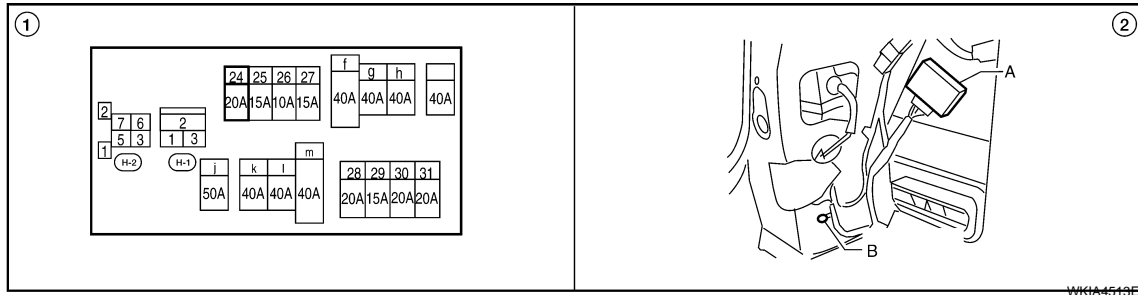

1. Fuse and fusible link box

2. A. Trailer tow control unit B303
B. Trailer tow ground
(View with rear lower finisher assembly LH removed)

System Description

INFOID:000000001719155

Power is supplied at all times

- through 20A fuse (No. 24, located in the fuse and fusible link box)
- to trailer tow control unit terminal 7.

Ground is supplied

- to trailer tow control unit terminal 5, and
- to trailer connector terminal 4
- through grounds B7 and B19.

TRAILER TAIL LAMP OPERATION

With the lighting switch in the parking and tail lamp ON (1ST) position, AUTO position (and the auto light system is activated) or headlamp ON (2ND) position, power is supplied

- through rear combination lamp LH
- to trailer tow control unit terminal 3.

The trailer tail lamps are controlled by the trailer tow control unit. The trailer tow control unit supplies power

- through trailer tow control unit terminal 1
- to trailer connector terminal 3.

TRAILER STOP, TURN SIGNAL AND HAZARD LAMP OPERATION

The trailer stop, turn signal and hazard lamps are all controlled by the trailer tow control unit. The trailer tow control unit regulates the amount of voltage supplied to the trailer lamps. If either turn signal or the hazard lamps are turned on and the trailer tow control unit gets a brake lamp input, the trailer tow control unit supplies more voltage to the trailer lamps to make them illuminate brighter.

Stop lamp input is supplied

- through rear combination lamp LH
- to trailer tow control unit terminal 8.

Left turn signal and hazard lamp input is supplied

- through rear combination lamp LH
- to trailer tow control unit terminal 4.

Right turn signal and hazard lamp input is supplied

- through rear combination lamp RH
- to trailer tow control unit terminal 9.

Based on the stop lamp, turn signal lamp and hazard lamp inputs to the trailer tow control unit, power is supplied to trailer stop/turn lamp LH

- through trailer tow control unit terminal 2
- to trailer harness connector terminal 2.

Power is also supplied to trailer stop/turn lamp RH

- through trailer tow control unit terminal 6
- to trailer harness connector terminal 1.

TRAILER TOW

< SERVICE INFORMATION >

Wiring Diagram - T/TOW -

INFOID:000000001719156

LT-T/TOW-01

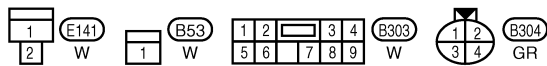
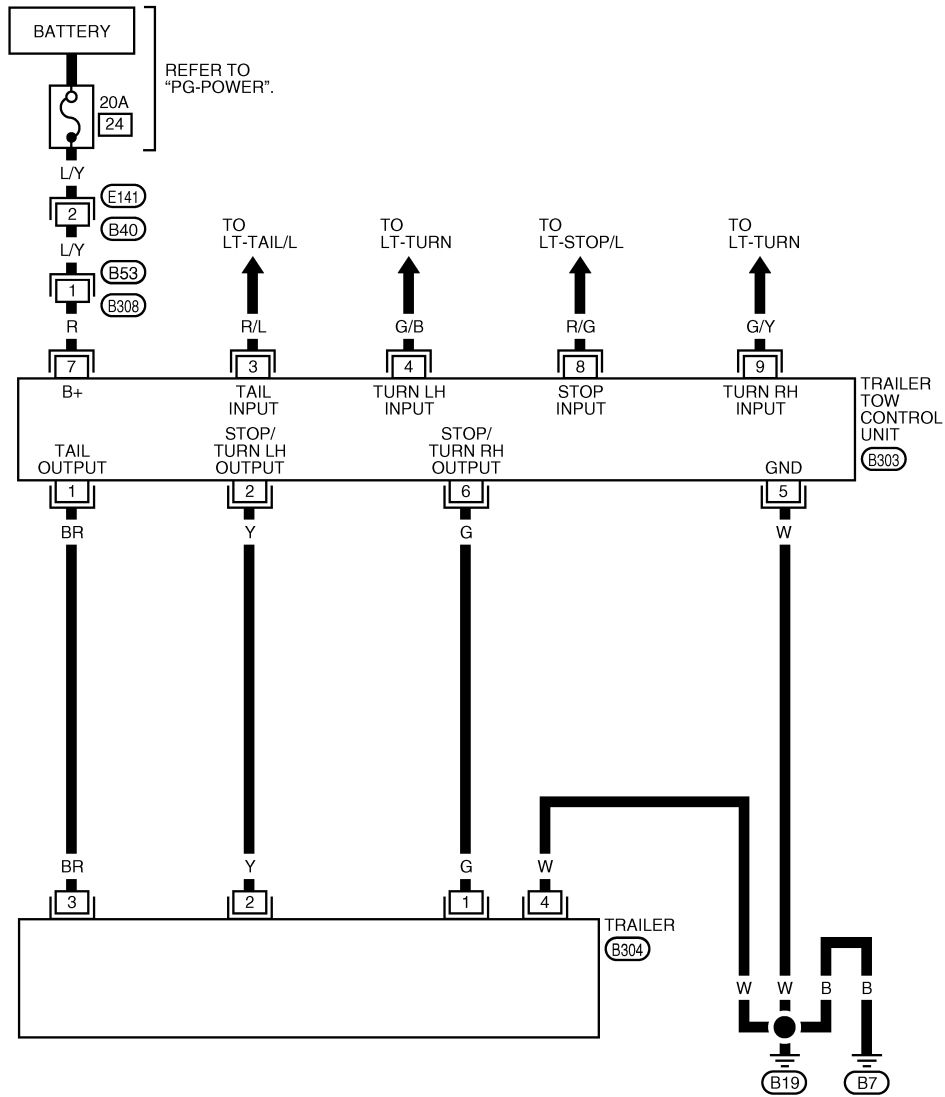

WKWA4712E

Trouble Diagnosis

INFOID:000000001719157

TRAILER TOW CONTROL UNIT INSPECTION TABLE

TRAILER TOW

< SERVICE INFORMATION >

Terminal No.	Wire color	Item	Condition	Voltage (Approx.)
1	BR	Tail lamps signal output	When tail lamps operate	Battery voltage
			All other conditions	0V
2	Y	Stop/LH turn lamp (output)	When brake pedal is depressed	Battery voltage
			When LH turn lamps or hazard lamps operate	Battery voltage (intermittently)
			All other conditions	0V
3	R/L	Tail lamps signal input	When tail lamps operate	Battery voltage
			All other conditions	0V
4	G/B	LH turn lamps input	When LH turn lamps or hazard lamps operate	Battery voltage (intermittently)
			All other conditions	0V
5	W	Ground	—	—
6	G	Stop/RH turn lamp (output)	When brake pedal is depressed	Battery voltage
			When RH turn lamps or hazard lamps operate	Battery voltage (intermittently)
			All other conditions	0V
7	R	Power supply	—	Battery voltage
8	R/G	Stop lamps signal input	When brake pedal is depressed	Battery voltage
			When brake pedal is released	0V
9	G/Y	RH turn lamps input	When RH turn lamps or hazard lamps operate	Battery voltage (intermittently)
			All other conditions	0V

A
B
C
D
E
F
G
H
I
J
L
M
N
O
P

LT

INTERIOR ROOM LAMP

< SERVICE INFORMATION >

INTERIOR ROOM LAMP

Component Parts and Harness Connector Location

INFOID:000000001719158

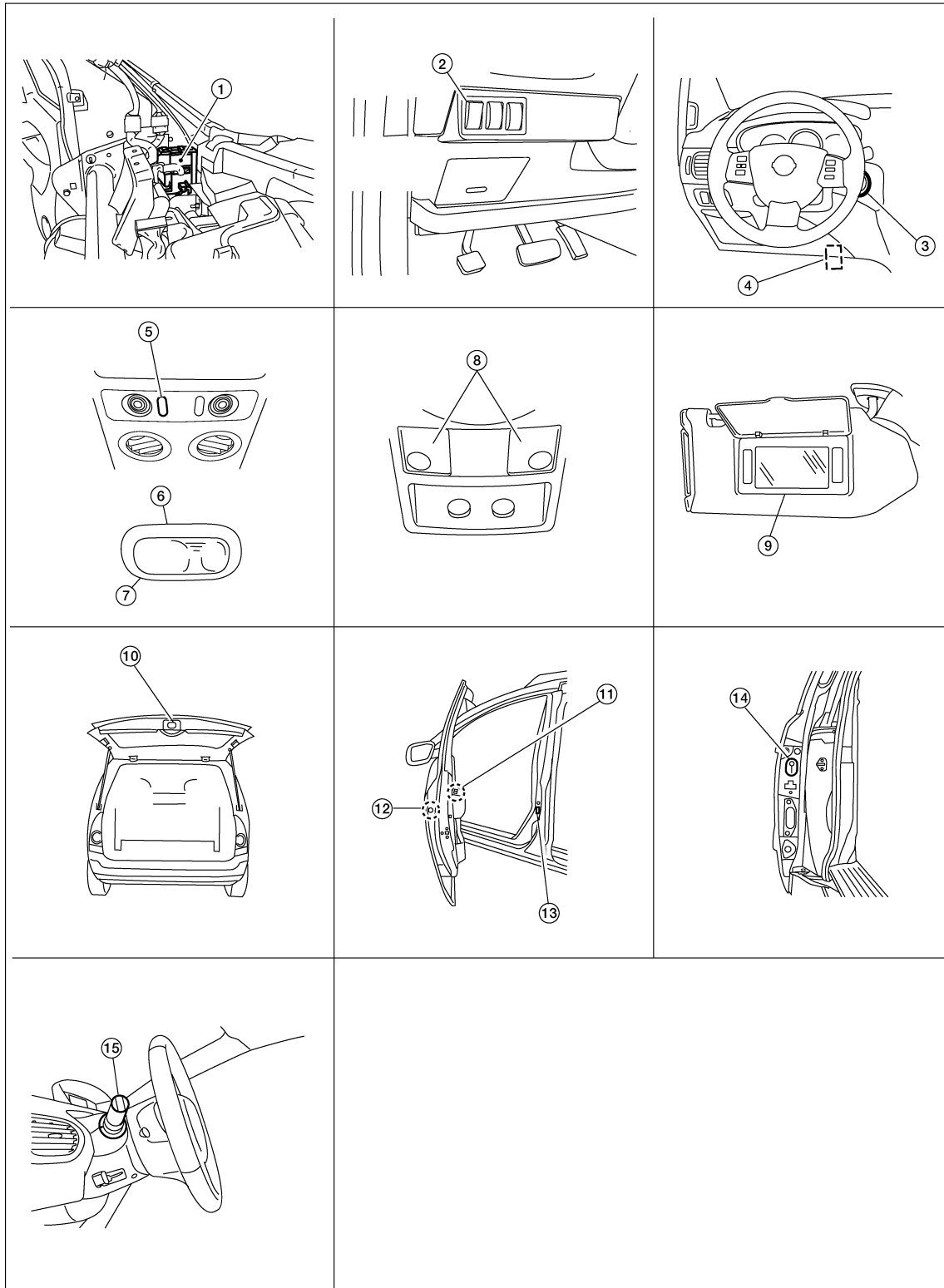

1. BCM M18, M19, M20 (view with instrument panel removed)

2. Lamps on demand switch M108

3. Key switch M27
Ignition keyhole illumination M25

4. Foot lamp LH M99
RH M100

5. Personal lamp with rear roof console
R52, R54

6. Personal lamp without rear roof console
R2, R7, R12, R13

WKIA5269E

INTERIOR ROOM LAMP

< SERVICE INFORMATION >

- | | | |
|-----------------------------------------------------------------------------------------------------------------------------|---------------------------------------------------------------------------------------------------------------------|--------------------------------------------------------------|
| 7. Cargo lamp R11 | 8. Room/map lamps R9 | 9. Vanity lamp (if equipped), LH R3
RH R8 |
| 10. Back door switch (without power
back door) D512
Back door latch (door ajar switch)
(with power back door) D511 | 11. Main power window and door lock/
unlock switch D7, D8
Power window and door lock/unlock
switch RH D105 | 12. Front door lock assembly LH (key
cylinder switch) D14 |
| 13. Front door switch LH B8
RH B108 | 14. Sliding door switch LH B46
RH B135 | 15. Combination switch (lighting switch)
M28 |

System Description

INFOID:000000001719159

When lamps on demand switch is in DOOR position, room/map lamp and personal lamp ON/OFF is controlled by timer according to signals from switches including key switch, door switches, unlock signal from keyfob, door lock and unlock switch, key cylinder switch, and ignition switch.

When room/map lamp and personal lamp turns ON, there is a gradual brightening over 1 second. When room/map lamp and personal lamp turns OFF, there is a gradual dimming over 1 second.

The room/map lamp and personal lamp timer is controlled by the BCM (body control module).

Room/map lamp and personal lamp timer control settings can be changed with CONSULT-III.

Ignition keyhole illumination turns ON when front door LH is opened (door switch ON) or key is removed from key cylinder. Illumination turns OFF when front door LH is closed (door switch OFF).

Step and foot lamp turns ON when any door is opened (door switch ON). Lamp turns OFF when all doors are closed (all door switches OFF).

POWER SUPPLY AND GROUND

Power is supplied at all times

- through 15A fuse [No. 19, located in the fuse block (J/B)]
- to key switch terminal 1, and
- through 15A fuse [No. 3, located in the fuse block (J/B)]
- to BCM terminal 57, and
- through 50A fusible link (letter j, located in the fuse and fusible link box)
- to BCM terminal 70.

When the key is inserted in key switch, power is supplied

- through the key switch terminal 2
- to BCM terminal 37.

With the ignition switch in the ON or START position, power is supplied

- through 10A fuse [No. 16, located in the fuse block (J/B)]
- to BCM terminal 38.

Ground is supplied

- to BCM terminal 67
- through grounds M57, M61 and M79.

When the front door LH is opened, ground is supplied

- to BCM terminal 47
- through front door switch LH terminal 1
- through case ground of front door switch LH.

When the front door RH is opened, ground is supplied

- to BCM terminal 12
- through front door switch RH terminal 1
- through case ground of front door switch RH.

When the sliding door LH is opened, ground is supplied

- to BCM terminal 48
- through sliding door switch LH terminal 1
- through case ground of sliding door switch LH.

When the sliding door RH is opened, ground is supplied

- to BCM terminal 13
- through sliding door switch RH terminal 1
- through case ground of sliding door switch RH.

When the liftgate is opened, ground is supplied

- to BCM terminal 43
- through back door switch terminal 1 (without power back door) or back door latch (door ajar switch) terminal 7 (with power back door)
- through back door switch terminal 3 (without power back door) or back door latch (door ajar switch) terminal 8 (with power back door)

A
B
C
D
E
F
G
H
I
J
LT
L
M
N
O
P

INTERIOR ROOM LAMP

< SERVICE INFORMATION >

- through grounds D403 and D404.

When doors are locked or unlocked by either door lock/unlock switch, BCM receives a ground signal

- to BCM terminal 22
- through main power window and door lock/unlock switch terminal 14 (with rear power vent windows) or terminal 12 (without rear power vent windows)
- through main power window and door lock/unlock switch terminal 17 (with rear power vent windows) or terminal 15 (without rear power vent windows), or
- through power window and door lock/unlock switch RH terminal 16
- through power window and door lock/unlock switch RH terminal 11
- through grounds M57, M61 and M79.

When the front door LH is unlocked by the key, the BCM receives a ground signal

- to BCM terminal 22
- through main power window and door lock/unlock switch terminal 14 (with rear power vent windows) or terminal 12 (without rear power vent windows)
- through main power window and door lock/unlock switch terminal 6 (with rear power vent windows) or terminal 7 (without rear power vent windows)
- through front door lock assembly LH (key cylinder switch) terminal 6
- through front door lock assembly LH (key cylinder switch) terminal 5
- through grounds M57, M61 and M79.

When the front door LH is locked by the key, the BCM receives a ground signal

- to BCM terminal 22
- through main power window and door lock/unlock switch terminal 14 (with rear power vent windows) or terminal 12 (without rear power vent windows)
- through main power window and door lock/unlock switch terminal 4 (with rear power vent windows) or terminal 6 (without rear power vent windows)
- through front door lock assembly LH (key cylinder switch) terminal 1
- through front door lock assembly LH (key cylinder switch) terminal 5
- through grounds M57, M61 and M79.

When a signal, or combination of signals is received by BCM, ground is supplied

- through BCM terminal 63
- to lamps on demand switch terminal 3
- through lamps on demand switch terminal 4 (with switch in DOOR position)
- to room/map lamps terminal 2
- to personal lamps 2nd and 3rd row terminal 2 (without rear roof console) or personal lamps 2nd and 3rd row terminal 3 (with rear roof console).

With power and ground supplied, the lamps illuminate.

SWITCH OPERATION

When front door switch LH is ON (door is opened), ground is supplied

- to ignition keyhole illumination terminal –
- through BCM terminal 1.

And power is supplied

- through BCM terminal 56
- to ignition keyhole illumination terminal +.

When any door switch is ON (door is opened), ground is supplied

- to front step lamp LH and RH terminal 1, and
- to foot lamp LH and RH terminal –
- through BCM terminal 62.

And power is supplied

- through BCM terminal 56
- to front step lamp LH and RH terminal 2
- to foot lamp LH and RH terminal +.

When room/map lamps switch is ON, ground is supplied

- to room/map lamps terminal 3
- through grounds M57, M61 and M79.

And power is supplied

- through BCM terminal 56
- to room/map lamps terminal 1.

When vanity lamp (if equipped), LH or RH is ON, ground is supplied

- to vanity lamp LH and RH terminal –
- through grounds M57, M61 and M79.

And power is supplied

INTERIOR ROOM LAMP

< SERVICE INFORMATION >

- through BCM terminal 56
- to vanity lamp LH and RH terminal +.

When personal lamps 2nd row LH or RH is ON, ground is supplied

- to personal lamps 2nd row LH or RH terminal 3 (without rear roof console assembly) or personal lamps 2nd row terminal 2 (with rear roof console assembly)
- through grounds M57, M61 and M79.

And power is supplied

- through BCM terminal 56
- to personal lamps 2nd row LH or RH terminal 1 (without rear roof console assembly) or personal lamps 2nd row terminal 1 (with rear roof console assembly).

When personal lamps 3rd row LH or RH is ON, ground is supplied

- to personal lamps 3rd row LH or RH terminal 3 (without rear roof console assembly) or personal lamps 3rd row terminal 2 (with rear roof console assembly)
- through grounds M57, M61 and M79.

And power is supplied

- through BCM terminal 56
- to personal lamps 3rd row LH or RH terminal 1 (without rear roof console assembly) or personal lamps 3rd row terminal 1 (with rear roof console assembly).

When cargo lamp is ON, ground is supplied

- to cargo lamp terminal 1
- through grounds M57, M61 and M79.

And power is supplied

- through BCM terminal 56
- to cargo lamp terminal 2.

ROOM LAMP TIMER OPERATION

When lamps on demand switch is in DOOR position and when all conditions below are met, BCM performs timer control (maximum 30 seconds) for interior room/map lamp ON/OFF.

Power is supplied at all times

- through 15A fuse [No. 19, located in the fuse block (J/B)]
- to key switch terminal 1.

Key is removed from ignition key cylinder (key switch OFF), power will not be supplied to BCM terminal 37.

Ground is supplied

- to BCM terminal 22
- through main power window and door lock/unlock switch terminal 14 (with rear power vent windows) or 12 (without rear power vent windows).

At the time that front door LH is opened, BCM detects that front door LH is unlocked. It determines that interior room/map lamp timer operation conditions are met and turns the interior room/map lamp ON for 30 seconds.

Key is in ignition key cylinder (key switch ON), power is supplied

- through key switch terminal 2
- to BCM terminal 37.

When key is removed from key switch (key switch OFF), power supply to BCM terminal 37 is terminated. BCM detects that key has been removed, determines that interior room/map lamp timer conditions are met, and turns the interior room/map lamp ON for 30 seconds.

When front door LH opens → closes and the key is not inserted in the key switch (key switch OFF), BCM terminal 47 changes between 0V (door open) → 12V (door closed). The BCM determines that conditions for interior room/map lamp operation are met and turns the interior room/map lamp ON for 30 seconds.

Timer control is canceled under the following conditions.

- Front door LH is locked [when locked with keyfob, main power window and door lock/unlock switch or front door lock assembly LH (key cylinder switch)]
- Front door LH is opened (front door switch LH turns ON)
- Ignition switch ON.

INTERIOR LAMP BATTERY SAVER CONTROL

If interior lamp is left "ON", it will not be turned out even when door is closed.

BCM turns off interior lamp automatically to save battery 30 minutes after ignition switch is turned OFF.

BCM controls interior lamps listed below:

- Vanity lamp (if equipped)
- Room/map lamp
- Cargo lamp
- Personal lamp
- Step lamps

A

B

C

D

E

F

G

H

I

J

LT

L

M

N

O

P

INTERIOR ROOM LAMP

< SERVICE INFORMATION >

- Foot lamps
 - Ignition keyhole illumination
- After lamps turn OFF by the battery saver system, the lamps illuminate again when
- signal received from keyfob, or main power window and door lock/unlock switch or front door lock assembly LH (key cylinder switch) is locked or unlocked
 - door is opened or closed
 - key is removed from or inserted in ignition key cylinder.

Interior lamp battery saver control period can be changed by the function setting of CONSULT-III and through the display (with color display).

INTERIOR ROOM LAMP

< SERVICE INFORMATION >

Schematic

INFOID:000000001719160

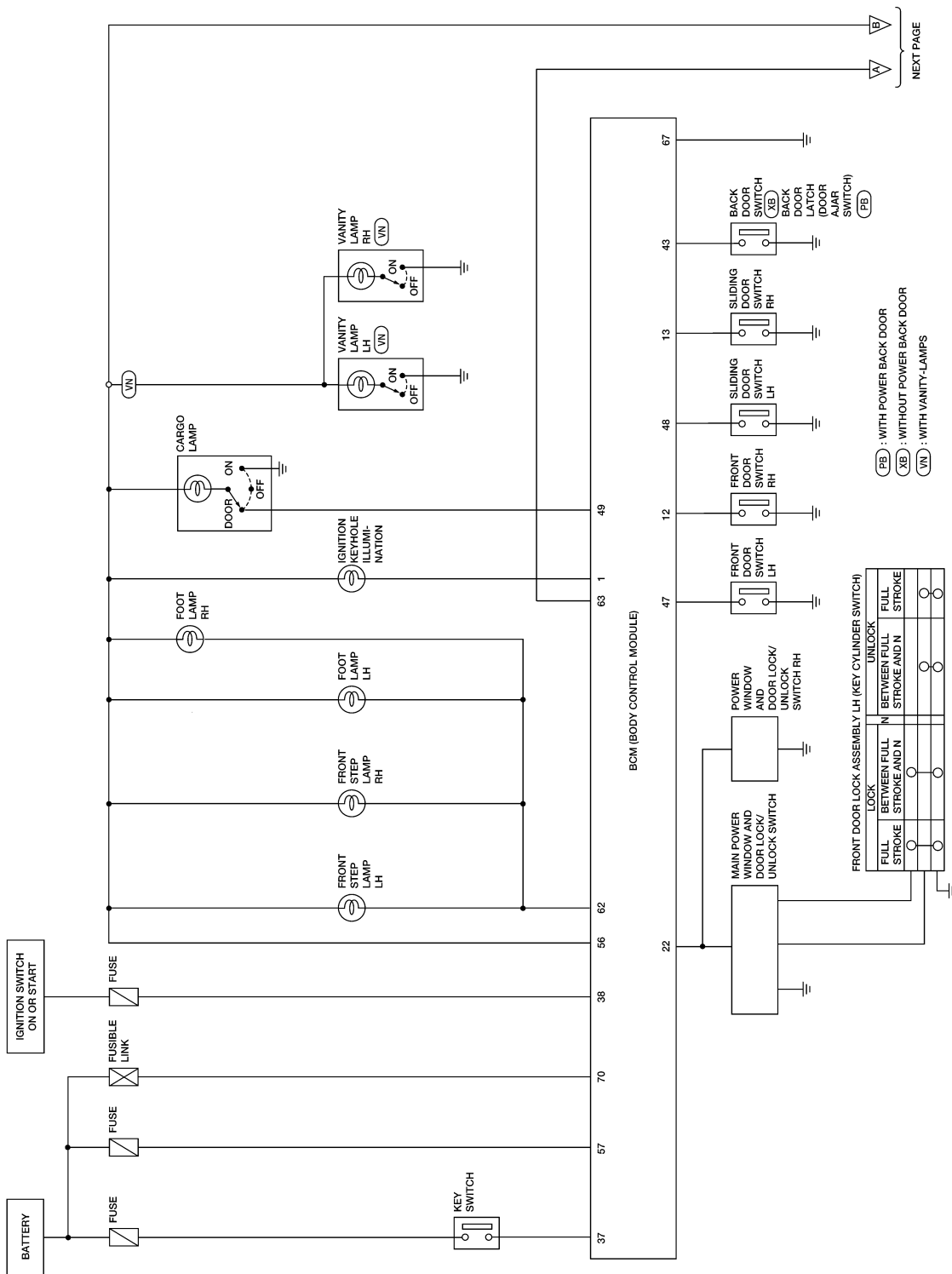

ALLWA0141GB

A
B
C
D
E
F
G
H
I
J
K
L
M
N
O
P

LT

INTERIOR ROOM LAMP

< SERVICE INFORMATION >

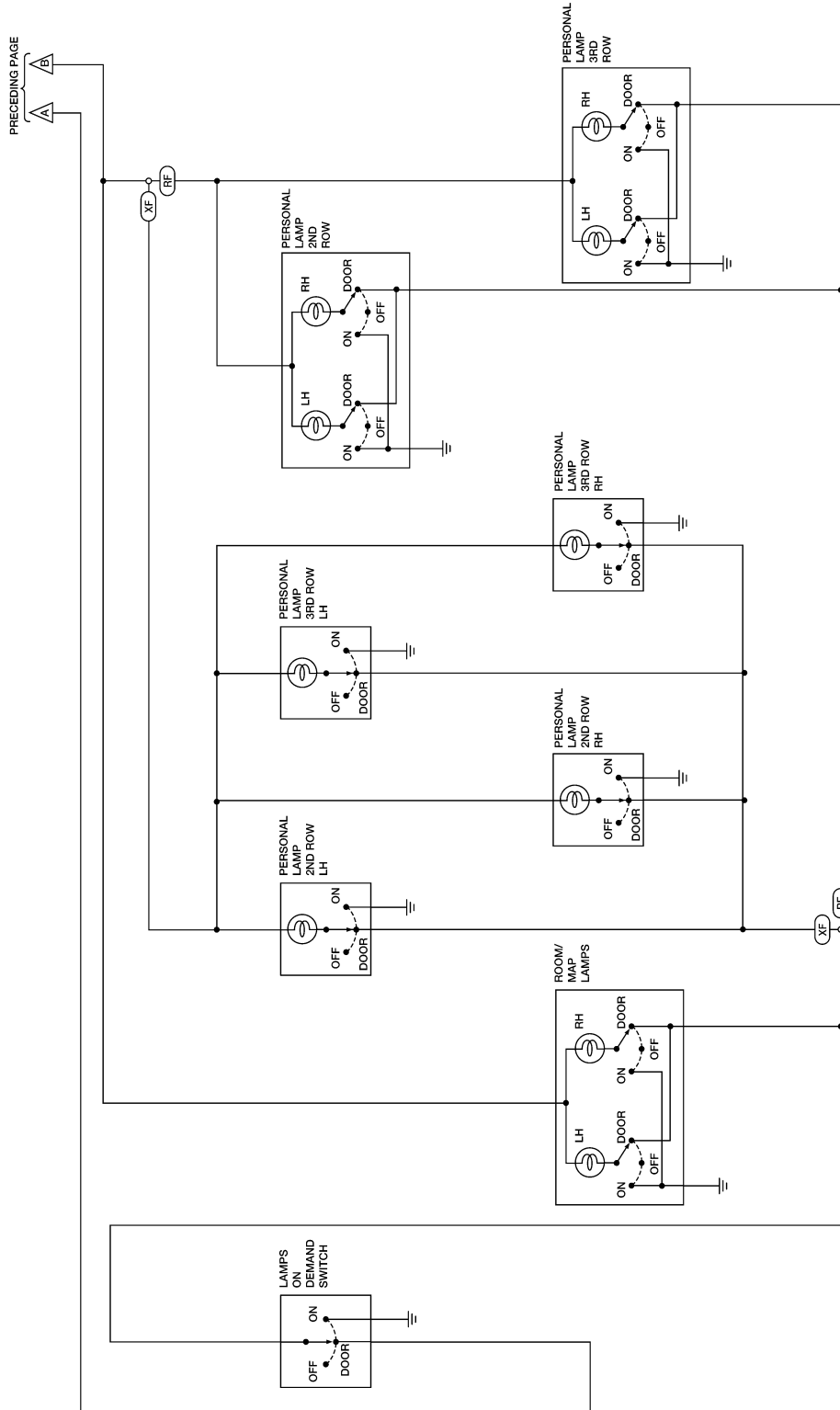

RF : WITH REAR ROOF CONSOLE
 XF : WITHOUT REAR ROOF CONSOLE

WKWA4714E

INTERIOR ROOM LAMP

< SERVICE INFORMATION >

Wiring Diagram - INT/L -

INFOID:000000001719161

LT-INT/L-01

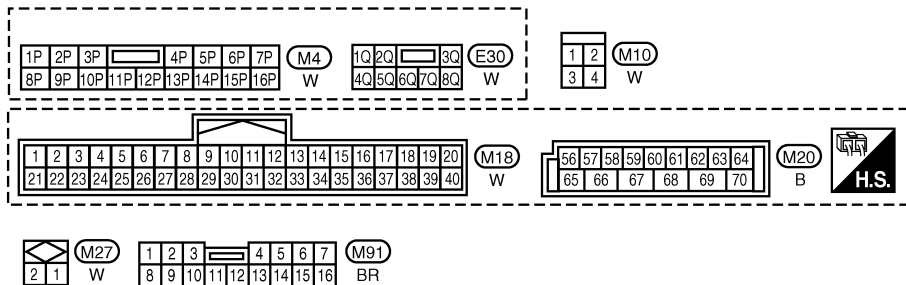
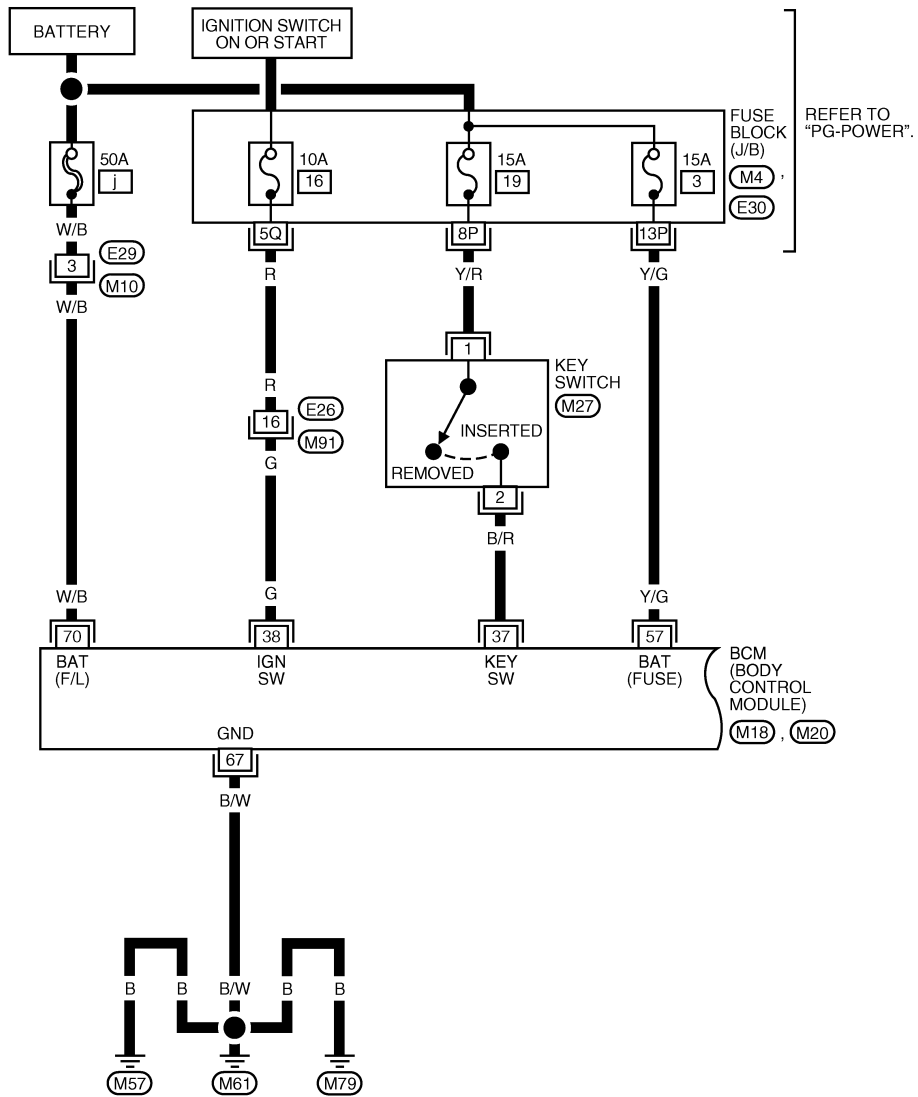

WKWA4715E

INTERIOR ROOM LAMP

< SERVICE INFORMATION >

LT-INT/L-02

: WITH POWER BACK DOOR

: WITHOUT POWER BACK DOOR

*1 : 4
 : 1

*2 : 4
 : 1

*3 : 14
 : 6

*4 : 7
 : 1

*5 : 8
 : 3

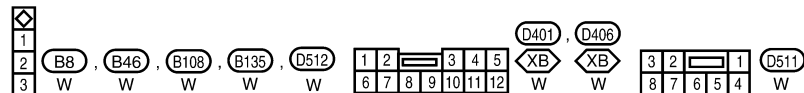
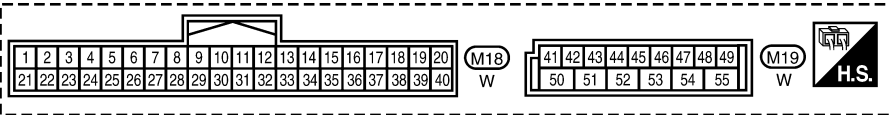
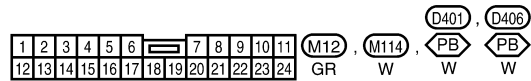
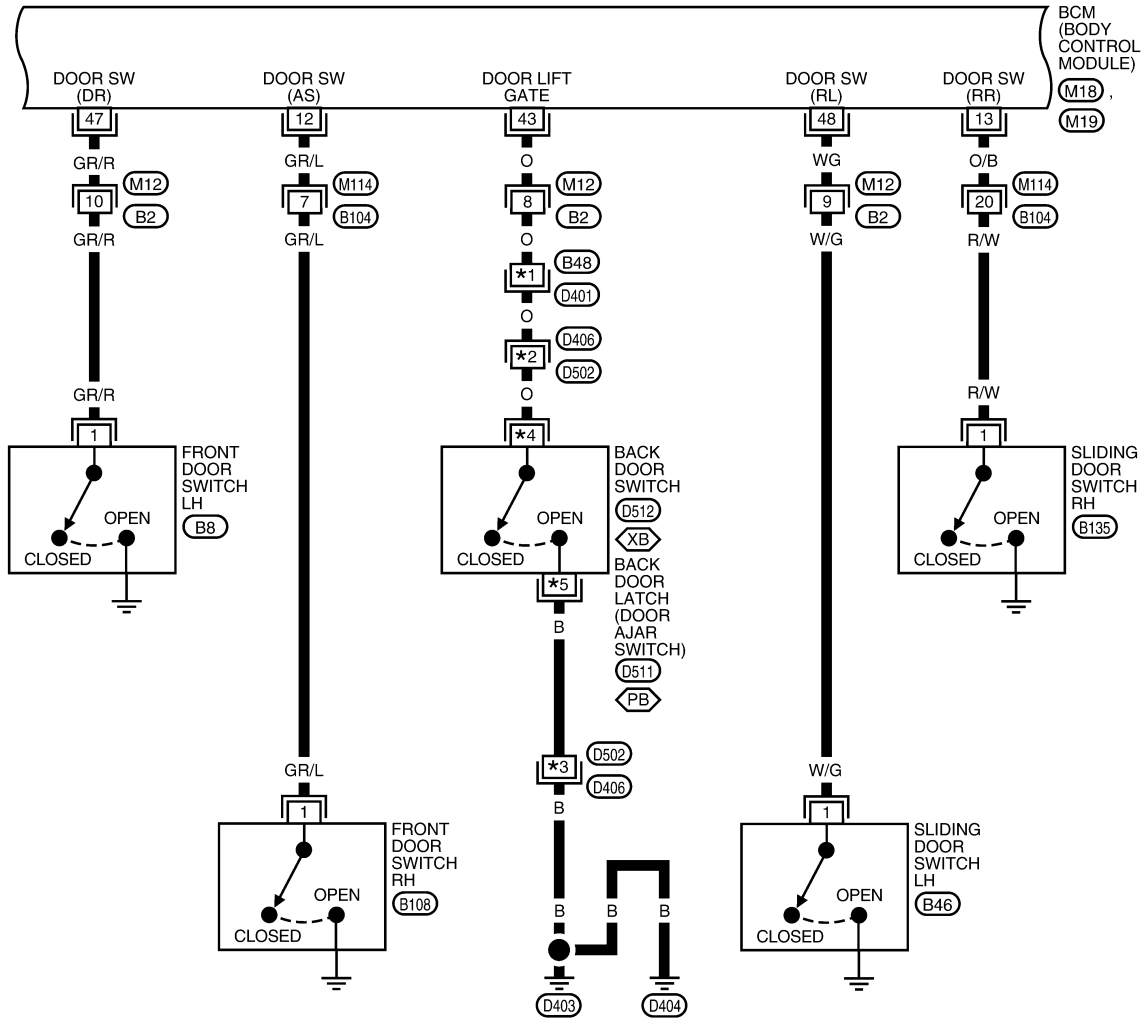

WKWA4716E

INTERIOR ROOM LAMP

< SERVICE INFORMATION >

LT-INT/L-03

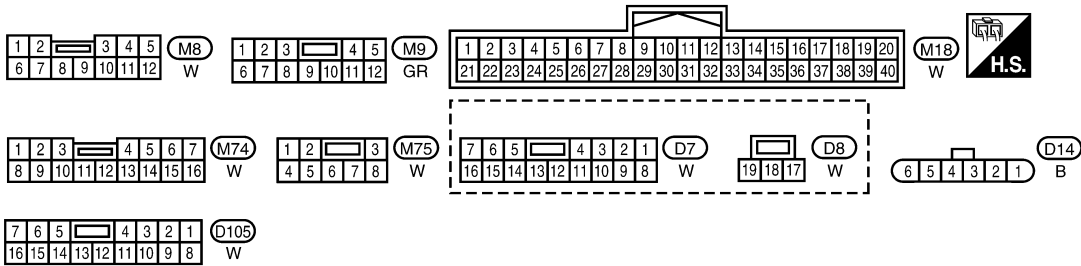
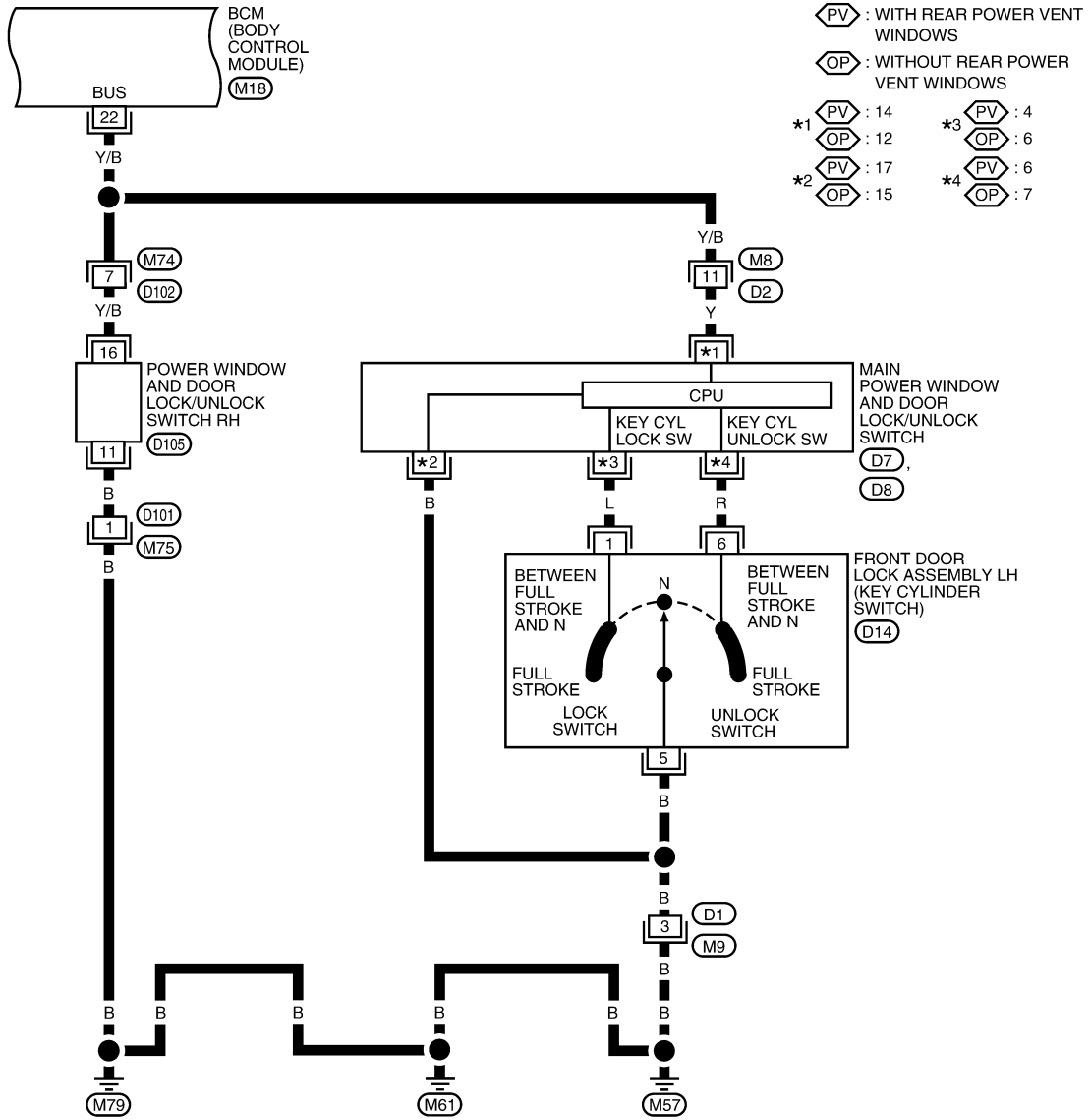

WKWA4717E

INTERIOR ROOM LAMP

< SERVICE INFORMATION >

LT-INT/L-05

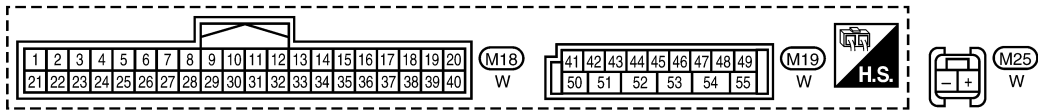
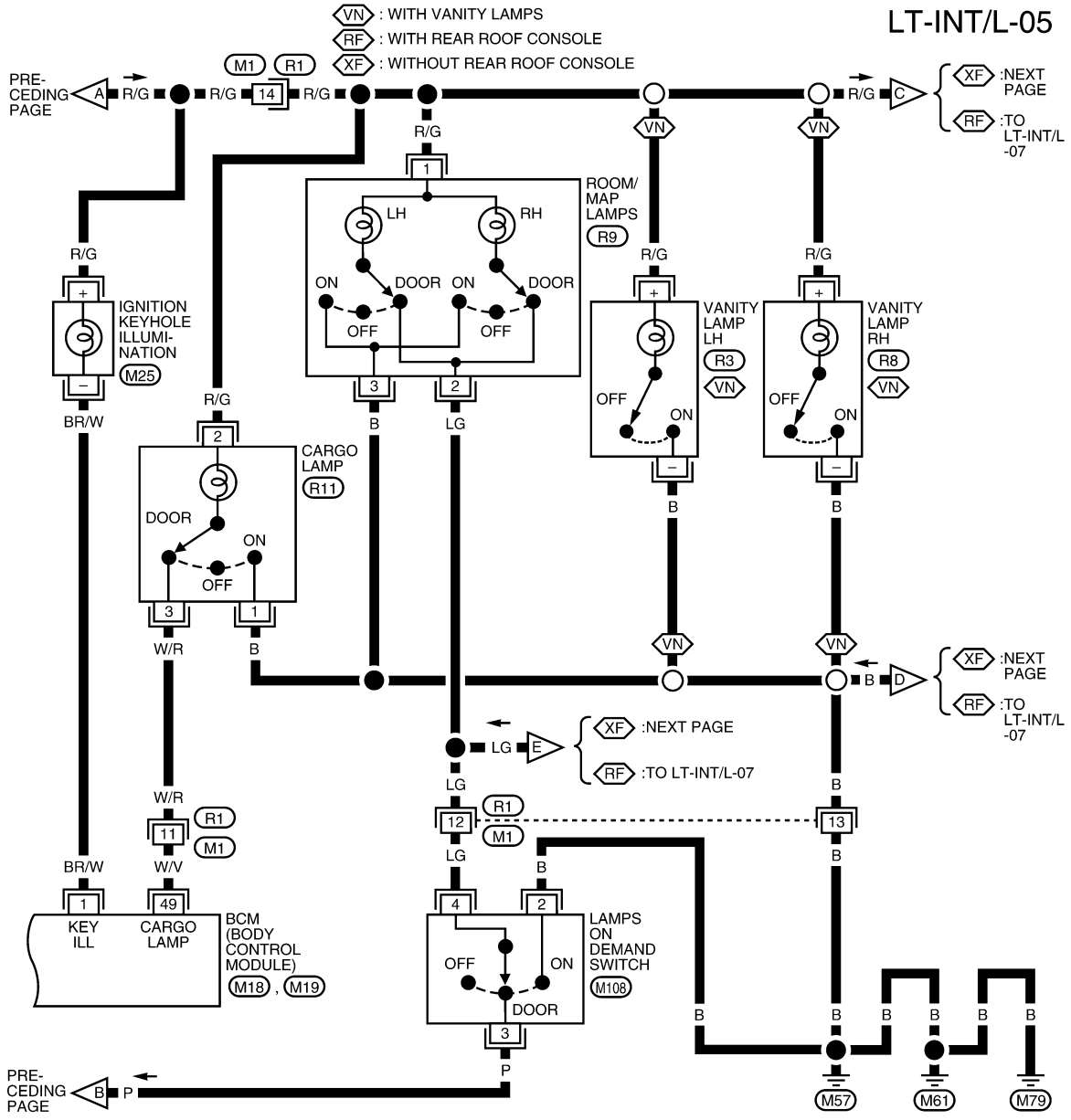

ALLWA0142GB

INTERIOR ROOM LAMP

< SERVICE INFORMATION >

WITHOUT REAR ROOF CONSOLE

LT-INT/L-06

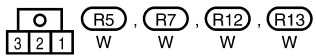
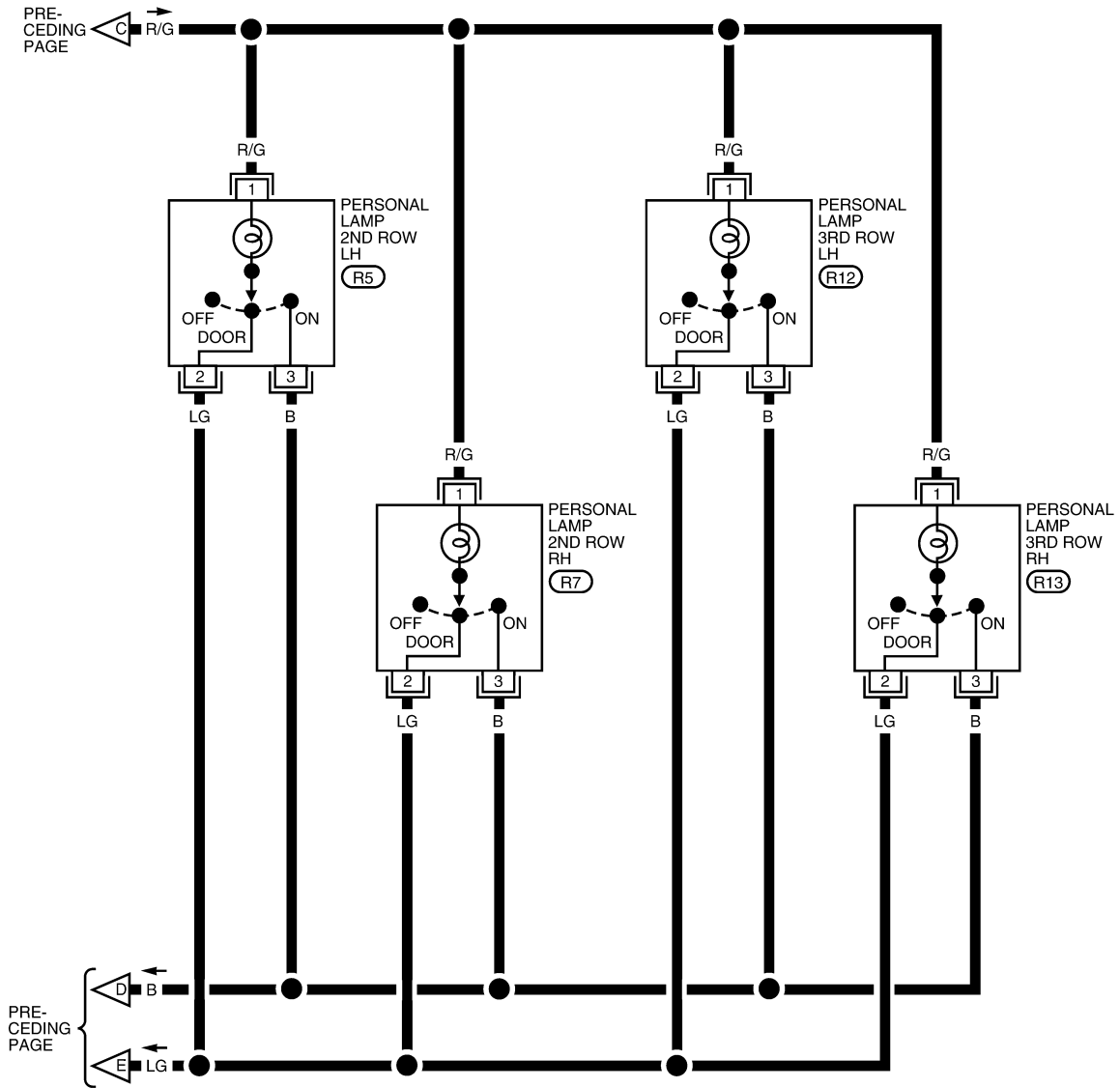

WKWA4720E

INTERIOR ROOM LAMP

< SERVICE INFORMATION >
WITH REAR ROOF CONSOLE

LT-INT/L-07

WD : WITH DVD ENTERTAINMENT SYSTEM
XD : WITHOUT DVD ENTERTAINMENT SYSTEM

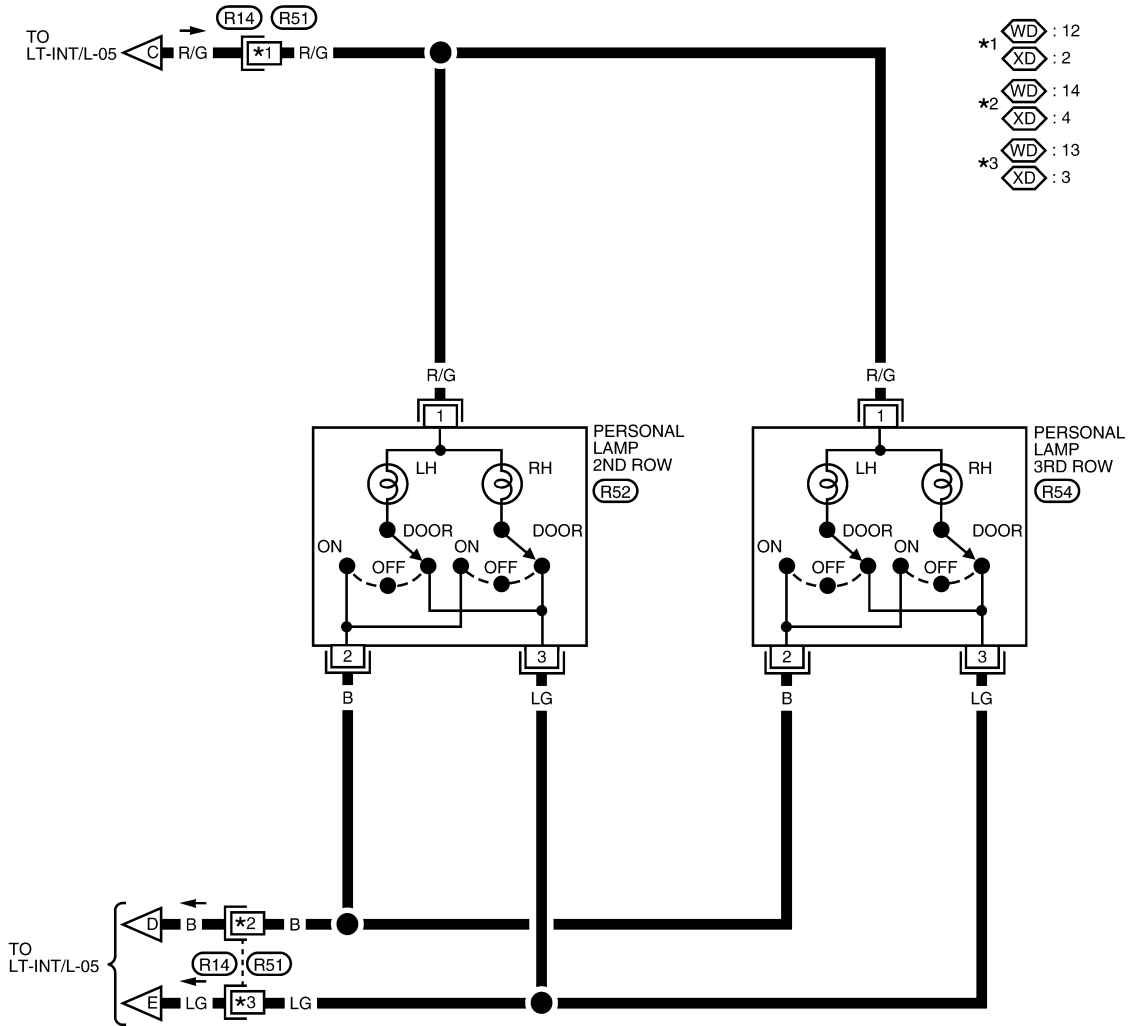

*1 WD : 12
XD : 2
*2 WD : 14
XD : 4
*3 WD : 13
XD : 3

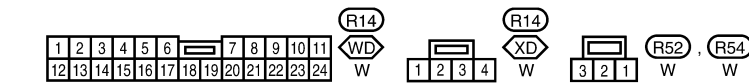

A
B
C
D
E
F
G
H
I
J
K
L
M
N
O
P

LT

Terminal and Reference Value for BCM

Refer to [BCS-11, "Terminal and Reference Value for BCM"](#).

How to Proceed with Trouble Diagnosis

1. Confirm the symptom or customer complaint.

WKWA4721E

INFOID:000000001719162

INFOID:000000001719163

INTERIOR ROOM LAMP

< SERVICE INFORMATION >

2. Understand operation description and function description. Refer to [LT-107, "System Description"](#).
3. Carry out the Preliminary Check. Refer to [LT-120, "Preliminary Check"](#).
4. Check symptom and repair or replace the cause of malfunction.
5. Does the interior room lamp operate normally? If YES: GO TO 6. If NO: GO TO 4.
6. Inspection End.

Preliminary Check

INFOID:000000001719164

SWITCH INSPECTION

- Ensure lamps on demand switch is in the DOOR or ON position.

BCM POWER SUPPLY AND GROUND CIRCUIT CHECK

Refer to [BCS-15, "BCM Power Supply and Ground Circuit Inspection"](#).

CONSULT-III Function (BCM)

INFOID:000000001719165

CONSULT-III can display each diagnostic item using the diagnostic test modes shown following.

BCM diagnostic test item	Diagnostic mode	Description
Inspection by part	WORK SUPPORT	Supports inspections and adjustments. Commands are transmitted to the BCM for setting the status suitable for required operation, input/output signals are received from the BCM and received data is displayed.
	DATA MONITOR	Displays BCM input/output data in real time.
	ACTIVE TEST	Operation of electrical loads can be checked by sending drive signal to them.
	SELF-DIAG RESULTS	Displays BCM self-diagnosis results.
	CAN DIAG SUPPORT MNTR	The result of transmit/receive diagnosis of CAN communication can be read.
	ECU PART NUMBER	BCM part number can be read.
	CONFIGURATION	Performs BCM configuration read/write functions.

WORK SUPPORT

Operation Procedure

1. Touch "INT LAMP" on "SELECT TEST ITEM" screen.
2. Touch "WORK SUPPORT" on "SELECT DIAG MODE" screen.
3. Touch "SET I/L D-UNLCK INTCON" on "SELECT WORK ITEM" screen.
4. Touch "START".
5. Touch "CHANGE SETT".
6. The setting will be changed and "CUSTOMIZING COMPLETED" will be displayed.
7. Touch "END".

Display Item List

Item	Description	CONSULT-III
SET I/L D-UNLCK INTCON	The 30 seconds operating function of the interior room lamps and the ignition keyhole illumination can be selected when front door LH is released (unlocked).	ON/OFF
ROOM LAMP ON TIME SET	The time in order to escalate illumination can be adjusted when the interior room lamps and the ignition keyhole illumination is turned on.	MODE 1 - 7
ROOM LAMP OFF TIME SET	The time in order to diminish illumination can be adjusted when the interior room lamps and the ignition keyhole illumination is turned off.	MODE 1 - 7

Reference between "MODE" and "TIME" for "TURN ON/OFF".

MODE	1	2	3	4	5	6	7
Time (sec.)	0.5	1	2	3	4	5	0

INTERIOR ROOM LAMP

< SERVICE INFORMATION >

DATA MONITOR

Operation Procedure

1. Touch "INT LAMP" on "SELECT TEST ITEM" screen.
2. Touch "DATA MONITOR" on "SELECT DIAG MODE" screen.
3. Touch either "ALL SIGNALS" or "SELECTION FROM MENU" on "SELECT MONITOR ITEM" screen.

ALL SIGNALS	Monitors all the signals.
SELECTION FROM MENU	Selects and monitors the individual signal.

4. Touch "START".
5. When "SELECTION FROM MENU" is selected, touch items to be monitored. When "ALL SIGNALS" is selected, all the items will be monitored.
6. Touch "RECORD" while monitoring, then the status of the monitored item can be recorded. To stop recording, touch "STOP".

Display Item List

Monitor item	Contents
IGN ON SW "ON/OFF"	Displays "IGN position (ON)/OFF, ACC position (OFF)" judged from the ignition switch signal.
KEY ON SW "ON/OFF"	Displays "Key inserted (ON)/key removed (OFF)" status judged from the key switch signal.
DOOR SW-DR "ON/OFF"	Displays status of the front door LH as judged from the front door switch LH signal. (Door is open: ON/Door is closed: OFF)
DOOR SW-AS "ON/OFF"	Displays "Door open (ON)/Door closed (OFF)" status, determined from front door switch RH signal.
DOOR SW-RR "ON/OFF"	Displays "Door open (ON)/Door closed (OFF)" status, determined from sliding door switch RH signal.
DOOR SW-RL "ON/OFF"	Displays "Door open (ON)/Door closed (OFF)" status, determined from sliding door switch LH signal.
BACK DOOR SW "ON/OFF"	Displays "Door open (ON)/Door closed (OFF)" status, determined from back door switch signal.
KEY CYL LK-SW "ON/OFF"	Displays "Door locked (ON)" status, determined from key cylinder lock switch in front door LH.
KEY CYL UN-SW "ON/OFF"	Displays "Door unlocked (OFF)" status, determined from key cylinder lock switch in front door LH.
CDL LOCK SW "ON/OFF"	Displays "Door locked (ON)/Door unlocked (OFF)" status, determined from locking detection switch in front door LH.
CDL UNLOCK SW "ON/OFF"	Displays "Door unlocked (OFF)" status, determined from locking detection switch in front door RH.
KEYLESS LOCK "ON/OFF"	Displays "Locked (ON)/Other (OFF)" status, determined from lock signal.
KEYLESS UNLOCK "ON/OFF"	Displays "Unlocked (ON)/Other (OFF)" status, determined from unlock signal.

ACTIVE TEST

Operation Procedure

1. Touch "INT LAMP" on "SELECT TEST ITEM" screen.
2. Touch "ACTIVE TEST" on "SELECT DIAG MODE" screen.
3. Touch item to be tested and check operation of the selected item.
4. During the operation check, touching "BACK" deactivates the operation.

Display Item List

Test item	Description
INT LAMP	Interior room lamp can be operated by any ON-OFF operations.
IGN ILLUM	Ignition keyhole illumination can be operated by ON-OFF operation.
STEP LAMP TEST	Step lamps can be operated by any ON-OFF operations.
LUGGAGE LAMP TEST	Cargo lamp can be operated by any ON-OFF operations.

INTERIOR ROOM LAMP

< SERVICE INFORMATION >

Room/Map Lamp Control Does Not Operate

INFOID:000000001719166

1. CHECK EACH SWITCH

Select "BCM" on CONSULT-III. With "INT LAMP" data monitor, make sure switches listed in display item list turn ON-OFF linked with switch operation. Refer to [LT-120. "CONSULT-III Function \(BCM\)"](#) for switches and their functions.

OK or NG

- OK >> GO TO 2.
- NG >> Inspect malfunctioning switch system.

2. ACTIVE TEST

1. Select "BCM" on CONSULT-III. Select "INT LAMP" active test.
2. When lamps on demand switch is in DOOR position, use active test to make sure interior room lamp operates.

OK or NG

- OK >> Replace BCM. Refer to [BCS-18. "Removal and Installation of BCM"](#).
- NG >> GO TO 3.

3. CHECK ROOM/MAP LAMPS INPUT

1. Turn ignition switch OFF.
2. Check voltage between room/map lamps harness connector terminal and ground.

Terminals		(-)	Voltage (approx.)
(+)			
Room/map lamps connector	Terminal		
R9	1	Ground	Battery voltage

OK or NG

- OK >> GO TO 4.
- NG >> GO TO 6.

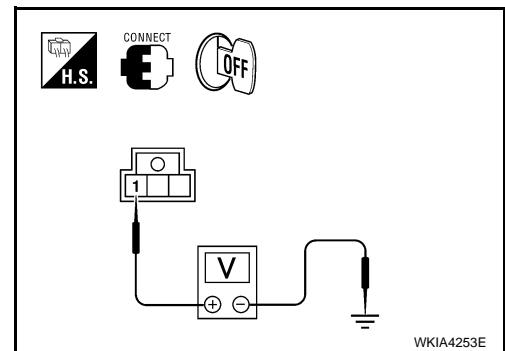

4. CHECK LAMPS ON DEMAND SWITCH

1. Disconnect lamps on demand switch connector.
2. Check continuity between lamps on demand switch terminals.

Lamps on demand switch		Condition	Continuity
Terminal			
3	4	Lamps on demand switch position: DOOR	Yes
		Lamps on demand switch position: OFF	No

OK or NG

- OK >> GO TO 5.
- NG >> Replace lamps on demand switch.

5. CHECK LAMPS ON DEMAND CIRCUIT

1. Connect lamps on demand switch connector.
2. Turn lamps on demand switch to DOOR position.

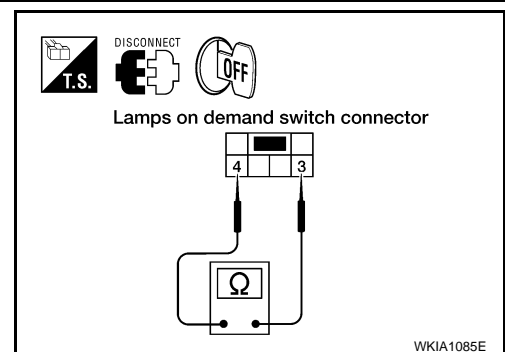

INTERIOR ROOM LAMP

< SERVICE INFORMATION >

3. Disconnect BCM connector.
4. Check continuity between BCM harness connector terminal and lamps on demand switch harness connector terminal.

A		B		Continuity
BCM connector	Terminal	Lamps on demand switch connector	Terminal	
M20	63	M108	3	Yes

OK or NG

- OK >> Replace BCM if room/map lamps do not work after setting the connector again. Refer to [BCS-18. "Removal and Installation of BCM"](#).
- NG >> Repair harness or connector.

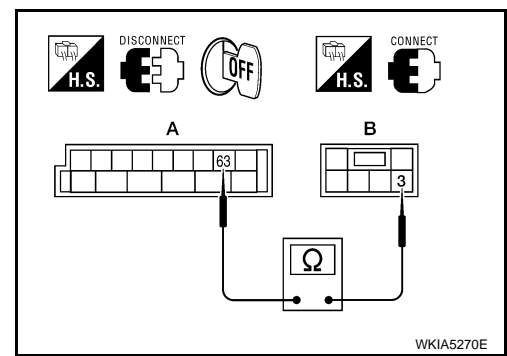

6.CHECK ROOM/MAP LAMPS CIRCUIT

1. Disconnect BCM connector and room/map lamps connector.
2. Check continuity between BCM harness connector terminal and room/map lamps harness connector terminal.

A		B		Continuity
BCM connector	Terminal	Room/map lamps connector	Terminal	
M20	56	R9	1	Yes

OK or NG

- OK >> Replace BCM if room/map lamps do not work after setting the connector again. Refer to [BCS-18. "Removal and Installation of BCM"](#).
- NG >> Repair harness or connector between BCM and room/map lamps or between room/map lamps and lamps on demand switch.

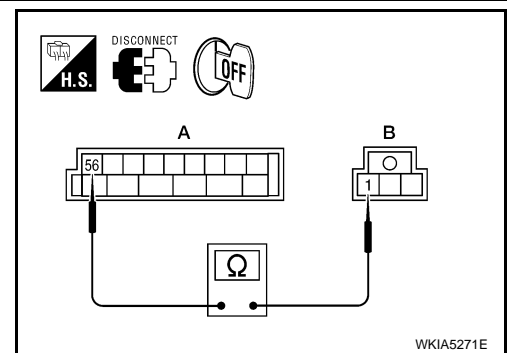

Personal Lamp Control Does Not Operate (Room/Map Lamps Operate)

INFOID:000000001719167

1.CHECK EACH DOOR SWITCH

Select "BCM" on CONSULT-III. With "INT LAMP" data monitor, make sure switches listed in display item list turn ON-OFF linked with switch operation. Refer to [LT-107. "System Description"](#) for switches and their function.

OK or NG

- OK >> GO TO 2.
- NG >> Inspect malfunctioning door switch.

2.CHECK PERSONAL LAMP OUTPUT

1. Turn ignition switch OFF.
2. Confirm lamps on demand switch is in the DOOR position.
3. Disconnect personal lamp connector.
4. Open any door.
5. Check voltage between personal lamp harness connector terminal 1 and ground.

1 - Ground : Battery voltage should exist.

OK or NG

- OK >> GO TO 3.
- NG >> Repair harness or connector.

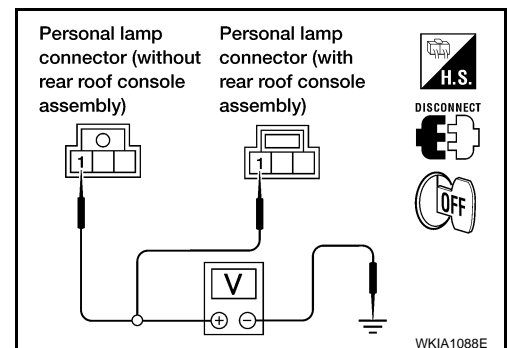

INTERIOR ROOM LAMP

< SERVICE INFORMATION >

3. CHECK PERSONAL LAMP CONTROL CIRCUIT

1. Disconnect lamps on demand switch connector.
2. Check continuity between lamps on demand switch harness connector M108 terminal 4 and personal lamp harness connector terminal 2 (without rear roof console assembly) or terminal 3 (with rear roof console assembly).

4 - 2 or 3 : Continuity should exist.

OK or NG

- OK >> Replace personal lamp.
NG >> Repair harness or connector.

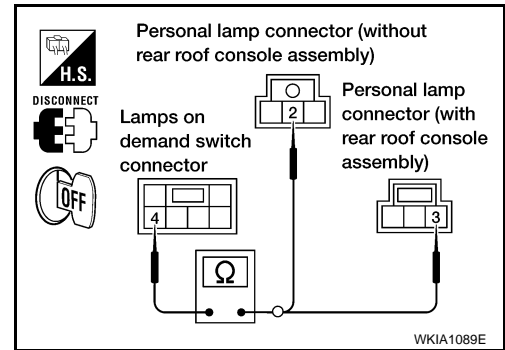

Ignition Keyhole Illumination Control Does Not Operate

INFOID:000000001719168

1. CHECK EACH SWITCH

Select "BCM" on CONSULT-III. With "INT LAMP" data monitor, make sure switches listed in display item list turn ON-OFF linked with switch operation. Refer to [LT-120, "CONSULT-III Function \(BCM\)"](#) for switches and their functions.

OK or NG

- OK >> GO TO 2.
NG >> Inspect malfunctioning switch system.

2. ACTIVE TEST

1. Select "BCM" on CONSULT-III. Select "INT LAMP".
2. Select "IGN ILLUM" active test to make sure lamp operates.

OK or NG

- OK >> Replace BCM. Refer to [BCS-18, "Removal and Installation of BCM"](#).
NG >> GO TO 3.

3. CHECK IGNITION KEYHOLE ILLUMINATION INPUT

1. Check voltage between ignition keyhole illumination harness connector M25 terminal + and ground.

+ - Ground : Battery voltage should exist.

OK or NG

- OK >> GO TO 4.
NG >> GO TO 6.

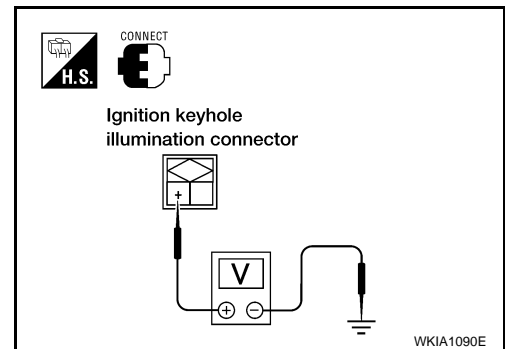

4. CHECK IGNITION KEYHOLE ILLUMINATION BULB

1. Turn ignition switch OFF.
2. Disconnect ignition keyhole illumination connector.
3. Check continuity between ignition keyhole illumination terminals + and -.

+ - - : Continuity should exist.

OK or NG

- OK >> GO TO 5.
NG >> Replace ignition keyhole illumination bulb.

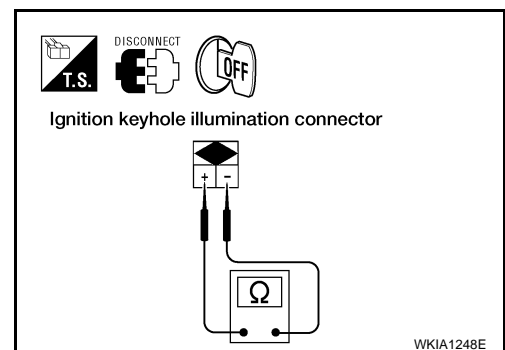

5. CHECK IGNITION KEYHOLE ILLUMINATION CONTROL CIRCUIT

INTERIOR ROOM LAMP

< SERVICE INFORMATION >

1. Disconnect BCM connector.
2. Check continuity between BCM harness connector M18 terminal 1 and ignition keyhole illumination harness connector M25 terminal -.

-- 1 : Continuity should exist.

OK or NG

- OK >> Replace BCM if ignition keyhole illumination does not work after setting the connector again. Refer to [BCS-18, "Removal and Installation of BCM"](#).
- NG >> Repair harness or connector.

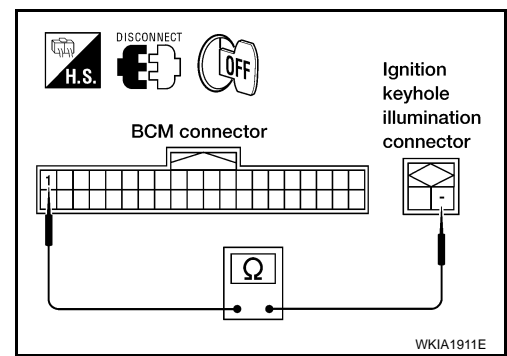

6.CHECK IGNITION KEYHOLE ILLUMINATION POWER SUPPLY CIRCUIT

1. Turn ignition switch OFF.
2. Disconnect BCM connector and ignition keyhole illumination connector.
3. Check continuity between BCM connector M20 (A) terminal 56 and ignition keyhole illumination connector M25 (B) terminal +.

+ - 56 : Continuity should exist.

OK or NG

- OK >> Replace BCM if ignition keyhole illumination does not work after setting the connector again. Refer to [BCS-18, "Removal and Installation of BCM"](#).
- NG >> Repair harness or connector.

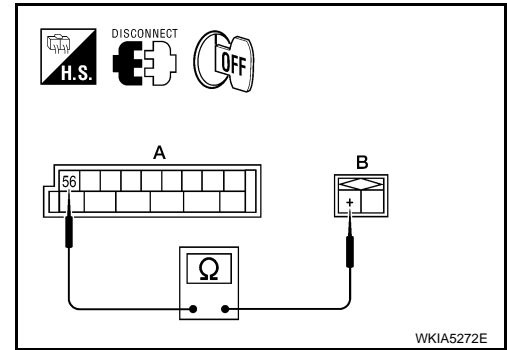

All Step/Foot Lamps Do Not Operate

INFOID:000000001719169

1.CHECK EACH DOOR SWITCH

Select "BCM" on CONSULT-III. With "INT LAMP" data monitor, make sure switches listed in display item list turn ON-OFF linked with switch operation. Refer to [LT-120, "CONSULT-III Function \(BCM\)"](#) for switches and their functions.

OK or NG

- OK >> GO TO 2.
- NG >> Inspect malfunctioning switch system.

2.CHECK STEP LAMP POWER SUPPLY

1. Turn ignition switch OFF.
2. Check voltage between front step lamp LH harness connector terminal and ground.

Terminals		(-)	Voltage (approx.)
(+) Terminal			
Front step lamp LH connector	Terminal	Ground	Battery voltage
D11	2		

OK or NG

- OK >> GO TO 3.
- NG >> GO TO 4.

3.CHECK STEP LAMP CONTROL CIRCUIT

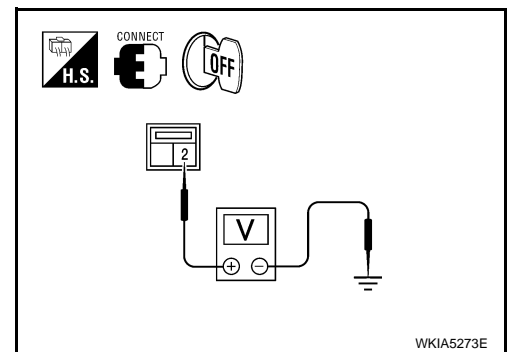

INTERIOR ROOM LAMP

< SERVICE INFORMATION >

1. Disconnect BCM connector and front step lamp LH connector.
2. Check continuity between BCM harness connector terminal and front step lamp LH harness connector terminal.

A		B		Continuity
BCM connector	Terminal	Front step lamp LH connector	Terminal	
M20	62	D11	1	Yes

OK or NG

- OK >> Replace BCM if front step lamp does not work after setting the connector again. Refer to [BCS-18. "Removal and Installation of BCM"](#).
- NG >> Repair harness or connector.

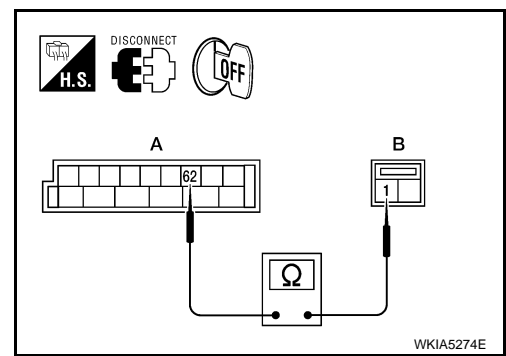

4. CHECK STEP LAMP POWER SUPPLY CIRCUIT

1. Disconnect BCM connector and front step lamp LH connector.
2. Check continuity between BCM harness connector terminal and front step lamp LH harness connector terminal.

A		B		Continuity
BCM connector	Terminal	Front step lamp LH connector	Terminal	
M20	56	D11	2	Yes

OK or NG

- OK >> Replace BCM if front step lamp does not work after setting the connector again. Refer to [BCS-18. "Removal and Installation of BCM"](#).
- NG >> Repair harness or connector.

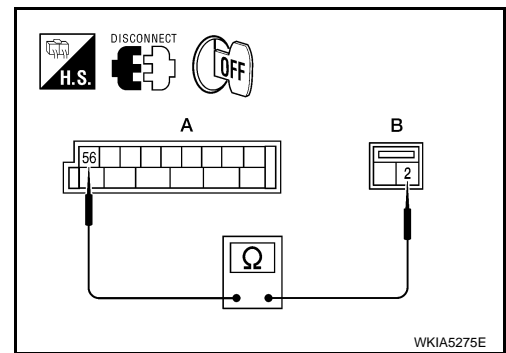

All Interior Room Lamps Do Not Operate

INFOID:000000001719170

1. CHECK POWER SUPPLY CIRCUIT

1. All interior room lamps switch are OFF.
2. Turn ignition switch ON.
3. Check voltage between BCM harness connector M20 terminal 56 and ground.

56 - Ground : Battery voltage should exist.

OK or NG

- OK >> Repair harness or connector. In a case of making a short circuit, be sure to disconnect battery negative cable after repairing harness and then reconnect.
- NG >> Replace BCM. Refer to [BCS-18. "Removal and Installation of BCM"](#).

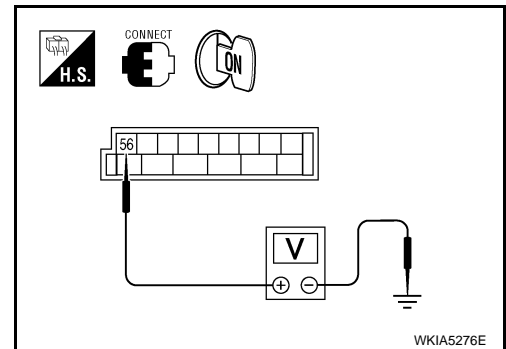

ILLUMINATION

< SERVICE INFORMATION >

ILLUMINATION

Component Parts and Harness Connector Location

INFOID:000000001719171

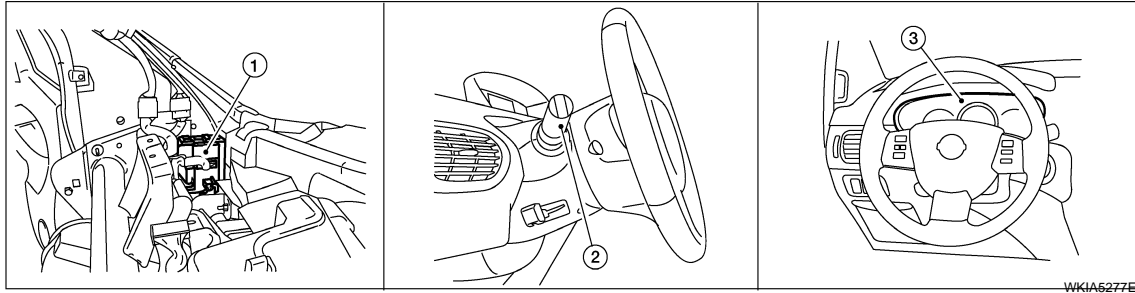

1. BCM M18, M20 (view with instrument panel removed)
2. Combination switch (lighting switch) M28
3. Combination meter M24 (illumination control)

System Description

INFOID:000000001719172

Control of the illumination lamps operation is dependent upon the position of the lighting switch (combination switch). When the lighting switch is placed in the 1ST or 2ND position or if the auto light system (if equipped) is activated the BCM (body control module) receives input signal requesting the illumination lamps to illuminate. This input signal is communicated to the IPDM E/R (intelligent power distribution module engine room) across the CAN communication lines. The CPU (central processing unit) of the IPDM E/R controls the tail lamp relay. This relay, when energized, directs power to the illumination lamps, which then illuminate.

Power is supplied at all times

- to ignition relay, located in the IPDM E/R, and
- through 15A fuse (No. 41, located in the IPDM E/R)
- to tail lamp relay, located in the IPDM E/R, and
- to CPU of the IPDM E/R, and
- through 50A fusible link (letter j, located in the fuse and fusible link box)
- to BCM terminal 70, and
- through 15A fuse [No. 3, located in fuse block (J/B)]
- to BCM terminal 57, and
- through 15A fuse (No. 34, located in the IPDM E/R)
- to CPU of the IPDM E/R, and
- through 15A fuse [No.19, located in fuse block (J/B)]
- to combination meter terminal 40.

With the ignition switch in the ON or START position, power is supplied

- to ignition relay, located in the IPDM E/R, and
- through 10A fuse [No. 16, located in the fuse block (J/B)]
- to BCM terminal 38, and
- through 10A fuse [No. 14, located in the fuse block (J/B)]
- to combination meter terminal 38.

With the ignition switch in the ACC or ON position, power is supplied

- through 10A fuse [No. 4, located in the fuse block (J/B)]
- to BCM terminal 11.

Ground is supplied

- to BCM terminal 67 and
- to combination meter terminals 20 and 21
- through grounds M57, M61 and M79, and
- to IPDM E/R terminals 38 and 60
- through grounds E9, E15 and E24.

ILLUMINATION OPERATION BY LIGHTING SWITCH

With the lighting switch in the 1ST or 2ND position or if the auto light system (if equipped) is activated, the BCM receives input signal requesting the illumination lamps to illuminate. This input signal is communicated to the IPDM E/R across the CAN communication lines. The CPU of the IPDM E/R controls the tail lamp relay which, when energized, directs power

A
B
C
D
E
F
G
H
I
J
LT
L
M
N
O
P

ILLUMINATION

< SERVICE INFORMATION >

- through IPDM E/R terminal 22
- to A/T device (illumination) terminal 3
- to front heated seat switch LH (illumination) terminal 5 (with heated seats)
- to pedal adjusting switch (illumination) terminal 5 (with adjustable pedals)
- to TCS OFF switch (illumination) terminal 3 (without VDC)
- to VDC OFF switch (illumination) terminal 3 (with VDC)
- to AV switch (illumination) terminal 3
- to hazard switch (illumination) terminal 3
- to main power window and door lock/unlock switch terminal 16
- to power window and door lock/unlock switch RH terminal 5
- to audio unit terminal 8
- to rear sonar system OFF switch terminal 5 (with rear sonar system)
- to lamps on demand switch terminal 5
- to DVD player terminal 12 (with DVD entertainment system)
- to glove box lamp terminal +
- to display unit terminal 4 (with monochrome display unit)
- to display control unit terminal 14 (with color display unit)
- to front air control terminal 8
- to NAVI control unit terminal 61 (with NAVI)
- to rear air control (rear) terminal 10
- to front heated seat switch RH (illumination) terminal 5 (with heated seats)
- to console lamp terminal 2
- to automatic door main switch terminal 5 (with power sliding door)
- to Bluetooth on indicator terminal 3 (with Bluetooth)
- to rear audio remote control unit terminal 6 (with rear audio remote control unit)
- through resistor-1 terminal 2 (with steering wheel audio control switches)
- through resistor-1 terminal 1 (with steering wheel audio control switches)
- through combination switch (spiral cable) terminal 26 (with steering wheel audio control switches)
- to spiral cable (steering switch) terminal 18 (with steering wheel audio control switches).

Illumination is controlled

- through combination meter (illumination control) terminal 1
- to A/T device terminal 4
- to TCS OFF switch terminal 4 (without VDC)
- to VDC OFF switch terminal 4 (with VDC)
- to AV switch terminal 4
- to hazard switch terminal 4
- to main power window and door lock/unlock switch terminal 12
- to power window and door lock/unlock switch RH terminal 1
- to audio unit terminal 7
- to rear sonar system OFF switch terminal 4 (with rear sonar system)
- to lamps on demand switch terminal 6
- to DVD player terminal 10 (with DVD entertainment system)
- to front air control terminal 9
- through combination switch (spiral cable) terminal 27 (with steering wheel audio control switches)
- to spiral cable (steering switch) terminal 21 (with steering wheel audio control switches).
- to console lamp terminal 1 (with power sliding door) and
- to automatic door main switch terminal 7 (with power sliding door).

Ground is supplied

- to glove box lamp terminal –
- to display unit terminal 6 (with monochrome display unit)
- to display control unit terminal 3 (with color display unit)
- to console lamp terminal 1 (without power sliding door)
- to rear air control (front) terminal 1
- to combination meter terminals 20 and 21
- through grounds M57, M61 and M79, and
- to rear audio remote control unit terminal 15 (with rear audio remote control unit)
- through grounds B7 and B19, and
- to NAVI control unit terminal 1 (with NAVI)
- to rear air control (rear) terminal 9
- through grounds B117 and B132.

With power and ground supplied, illumination lamps illuminate.

ILLUMINATION

< SERVICE INFORMATION >

EXTERIOR LAMP BATTERY SAVER CONTROL

When the combination switch (lighting switch) is in the 1ST or 2ND position or if auto light system (if equipped) is activated and the ignition switch is turned from ON or ACC to OFF, the battery saver control function is activated.

Under this condition, the illumination lamps remain illuminated for 5 minutes, then the illumination lamps are turned off.

When the lighting switch is turned from OFF to 1ST or 2ND position (or if auto light system is activated) after illumination lamps are turned off by the battery saver control, the illumination lamps illuminate again.

Exterior lamp battery saver control mode can be changed by the function setting of CONSULT-III and the display (with NAVI).

CAN Communication System Description

INFOID:000000001719173

Refer to [LAN-3. "CAN Communication System"](#).

A
B
C
D
E
F
G
H
I
J
LT
L
M
N
O
P

ILLUMINATION

< SERVICE INFORMATION >

Schematic

INFOID:000000001719174

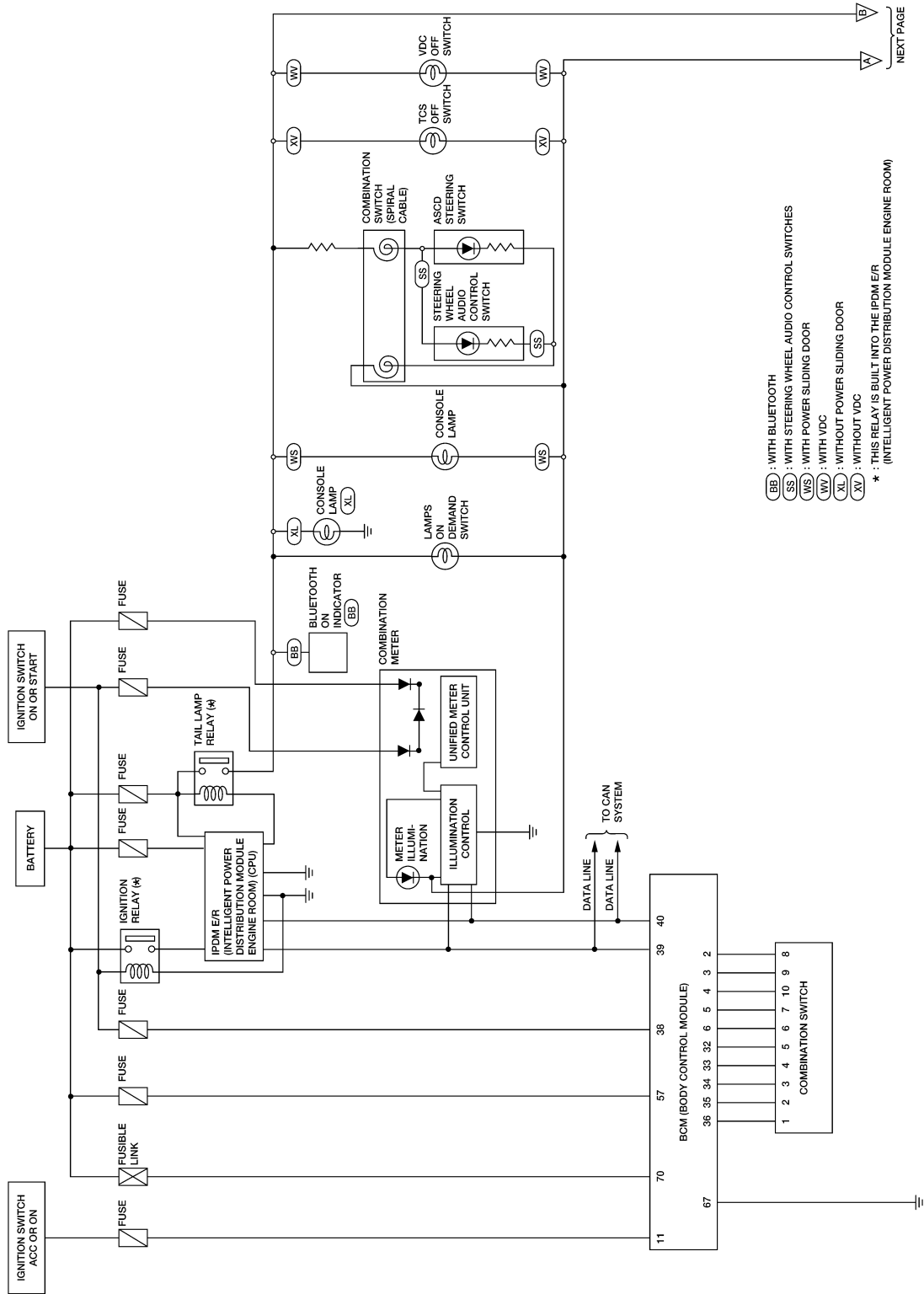

ALLWA0143GB

ILLUMINATION

< SERVICE INFORMATION >

Wiring Diagram - ILL -

INFOID:000000001719175

LT-ILL-01

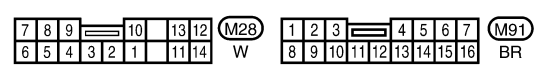
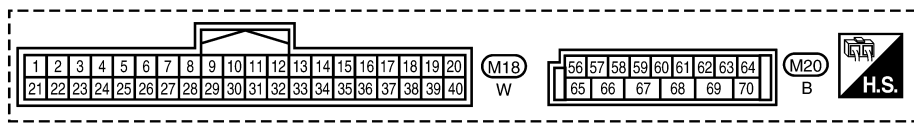
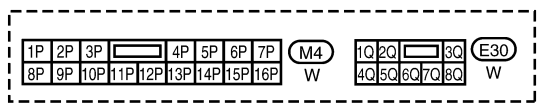
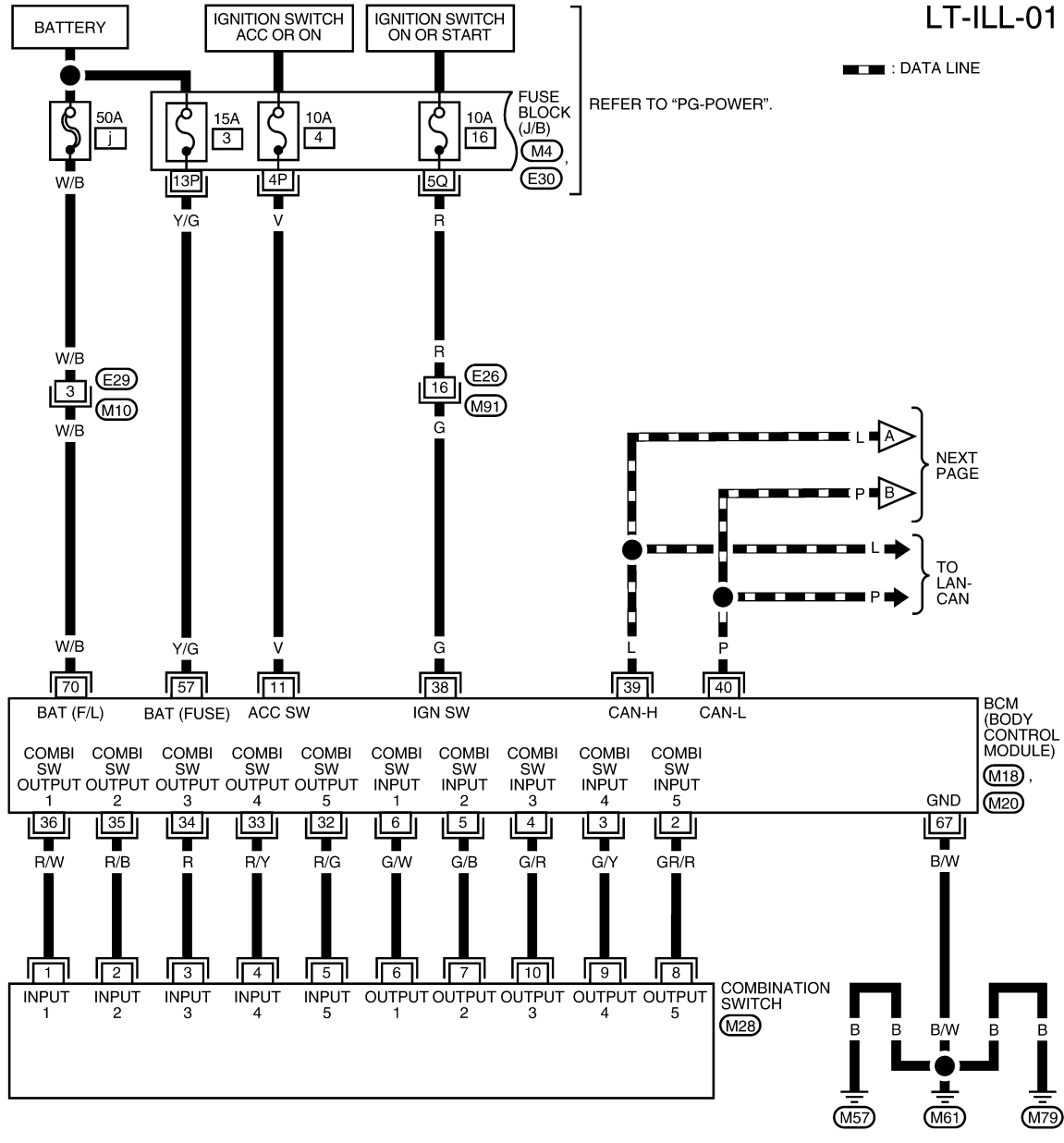

WKWA4724E

ILLUMINATION

< SERVICE INFORMATION >

LT-ILL-02

▬ : DATA LINE

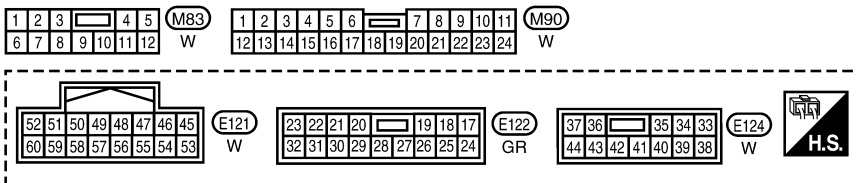
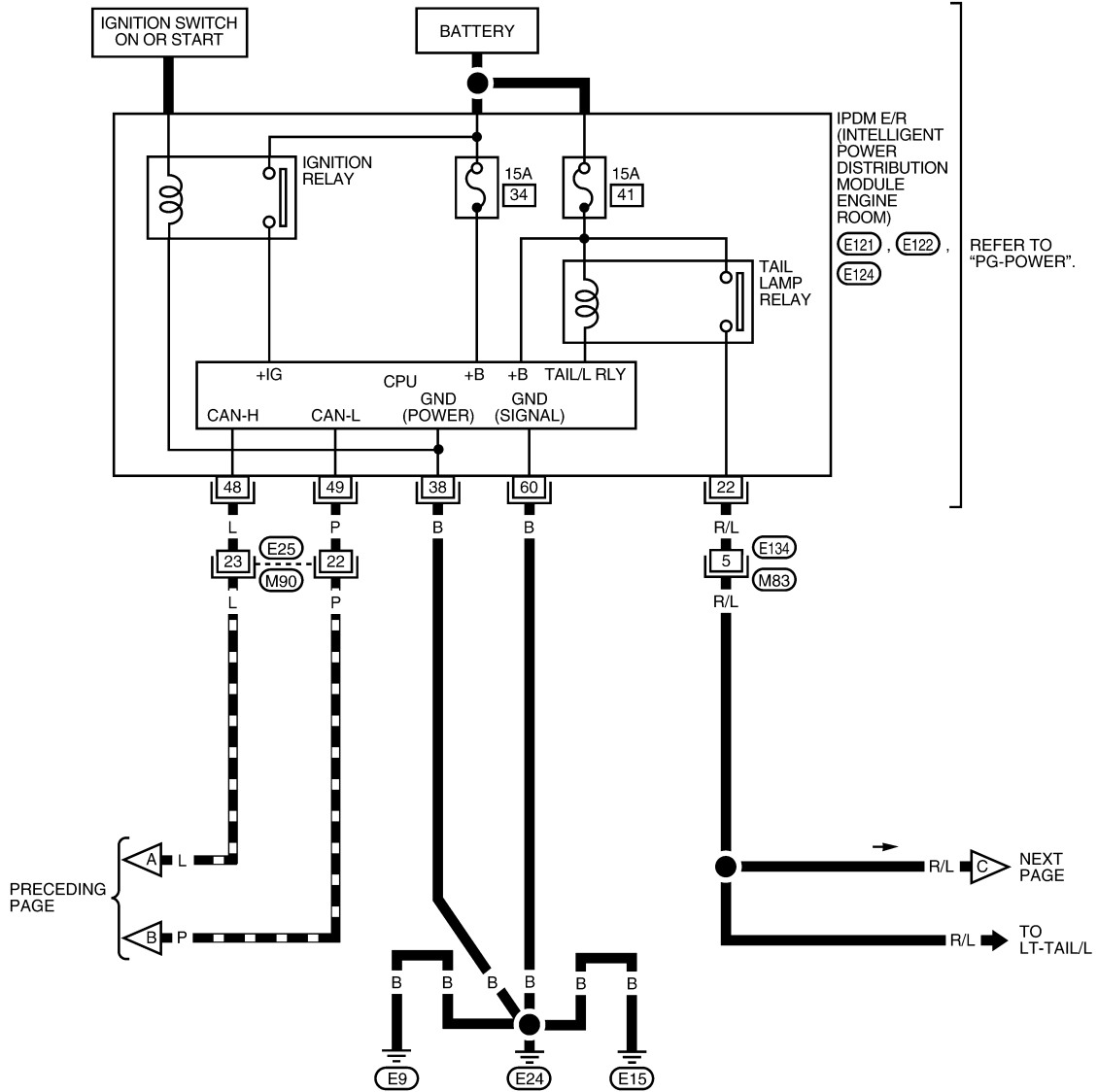





WKWA4725E

ILLUMINATION

< SERVICE INFORMATION >

LT-ILL-03

-  : WITH ADJUSTABLE PEDALS
-  : WITH HEATED SEATS
-  : WITH VDC
-  : WITHOUT VDC

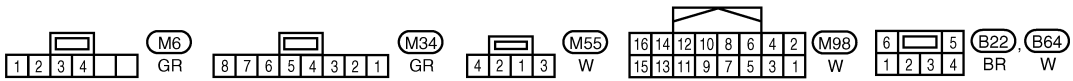
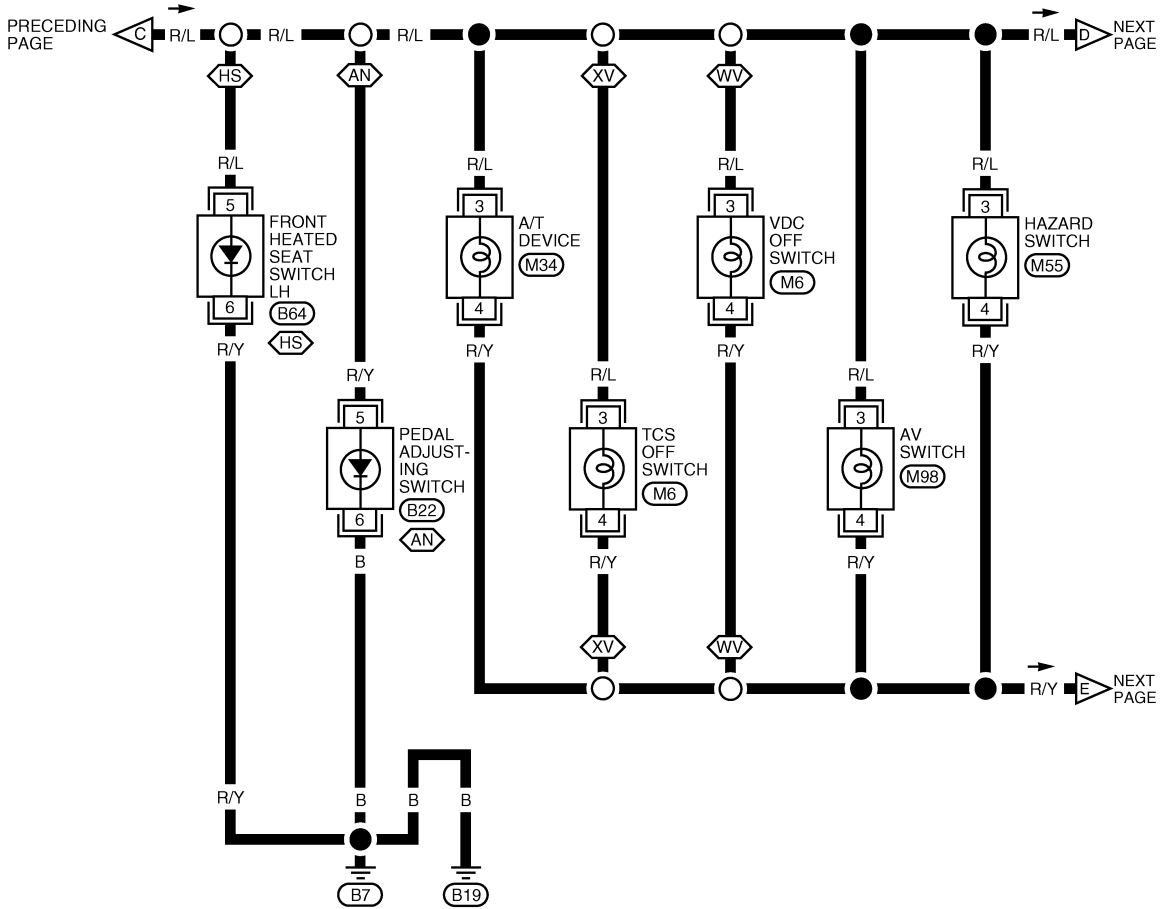

WKWA4726E

ILLUMINATION

< SERVICE INFORMATION >

LT-ILL-04

SO : WITH REAR SONAR SYSTEM
 WD : WITH DVD ENTERTAINMENT SYSTEM

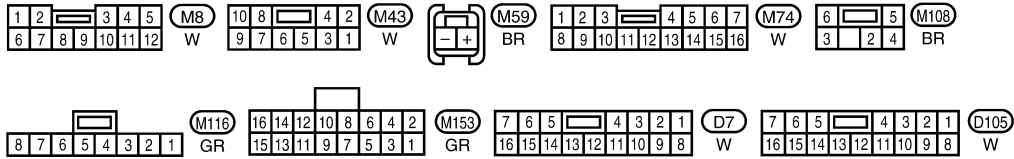
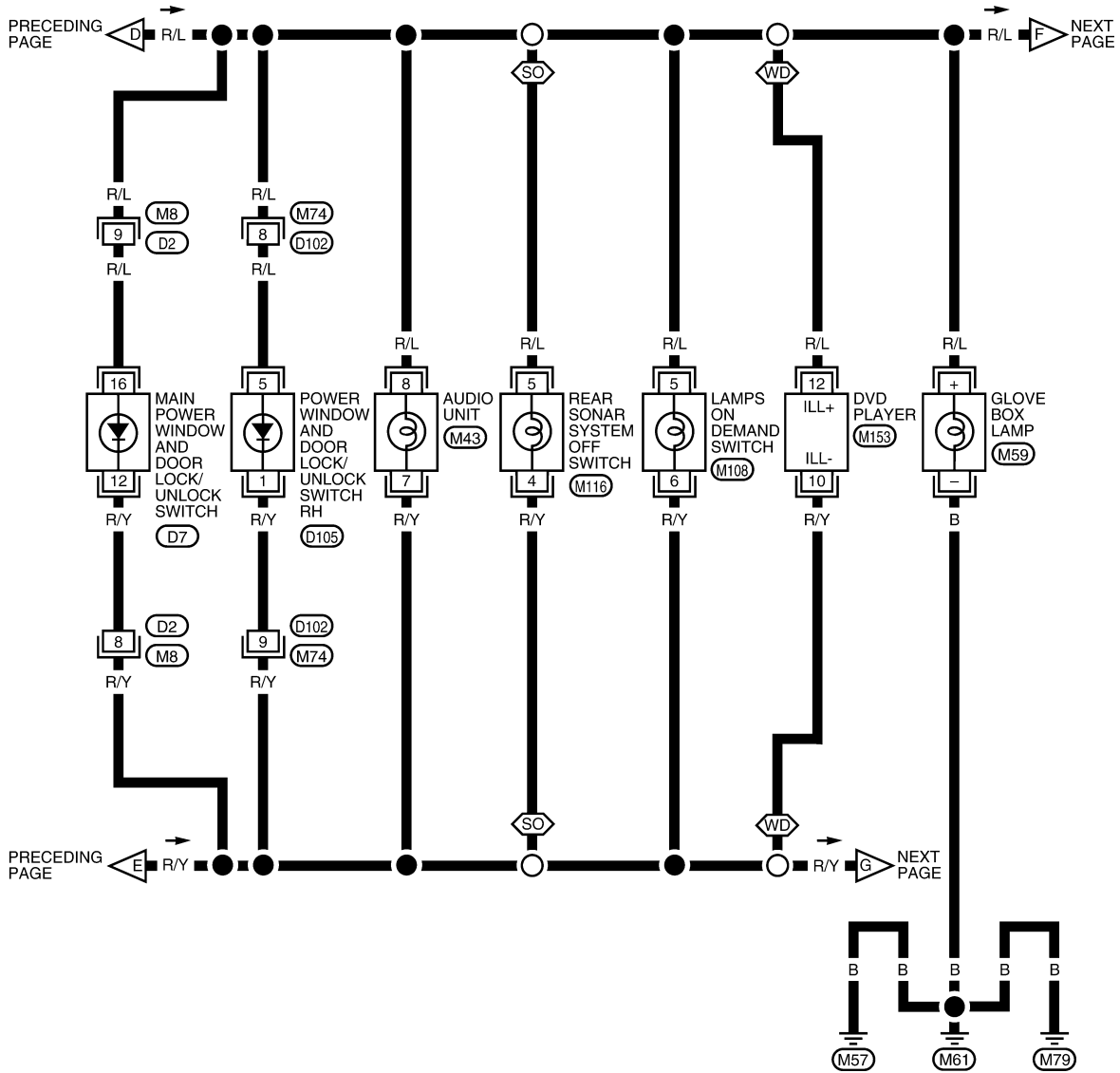

WKWA4727E

A
B
C
D
E
F
G
H
I
J
L
M
N
O
P



ILLUMINATION

< SERVICE INFORMATION >

LT-ILL-05

CD : WITH COLOR DISPLAY
 MC : WITH MONOCHROME DISPLAY

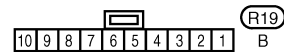
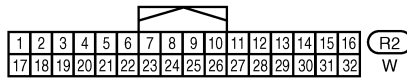
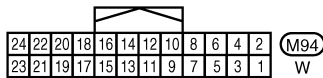
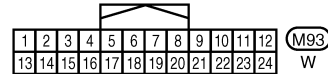
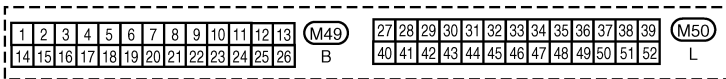
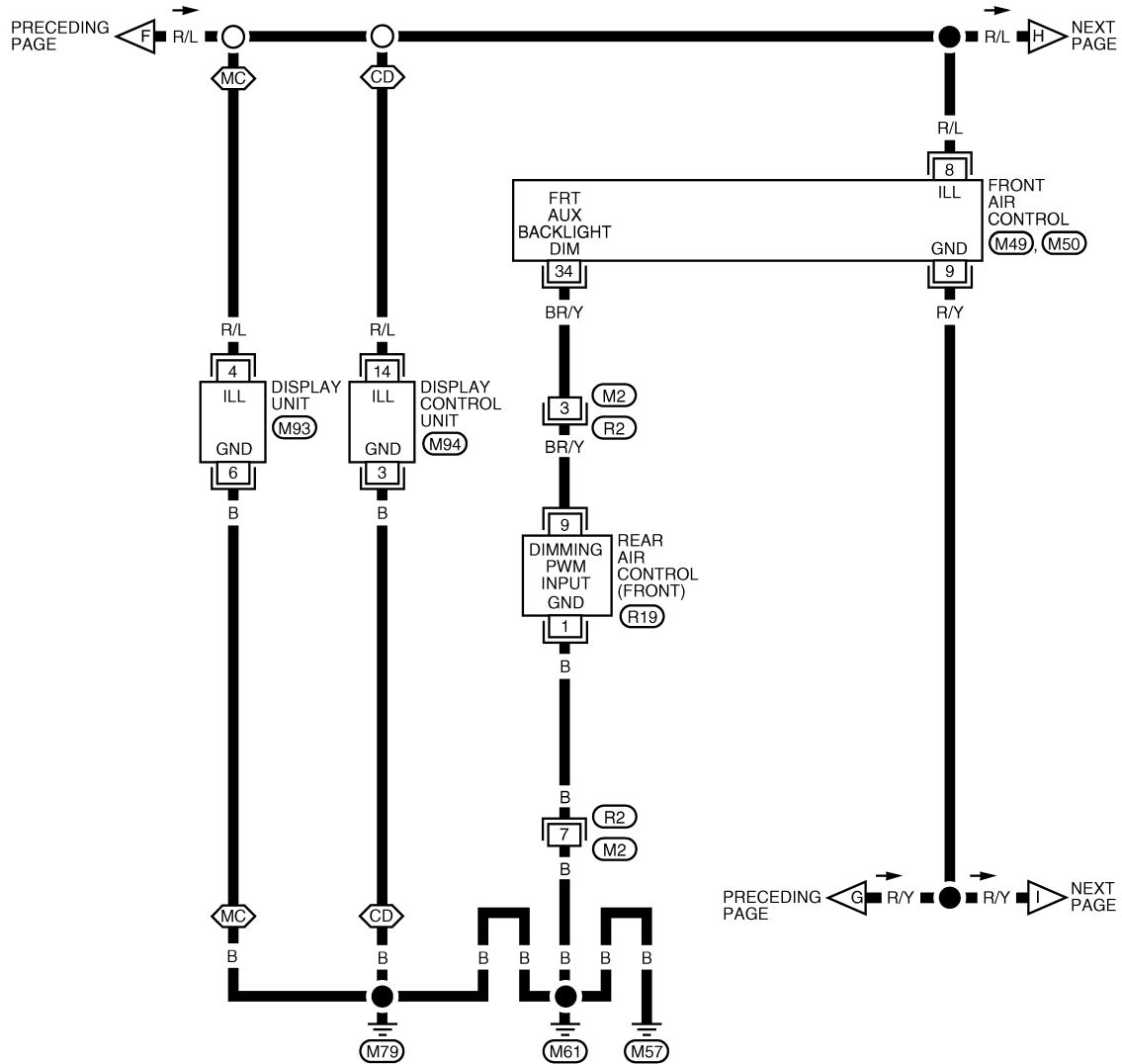

WKWA4728E

ILLUMINATION

< SERVICE INFORMATION >

LT-ILL-06

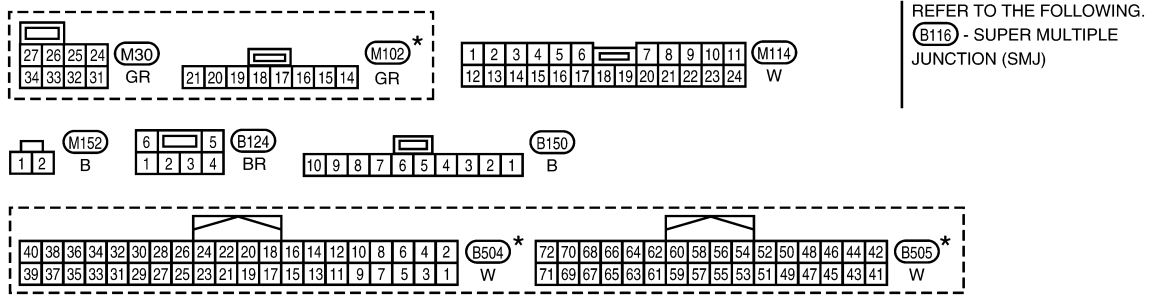
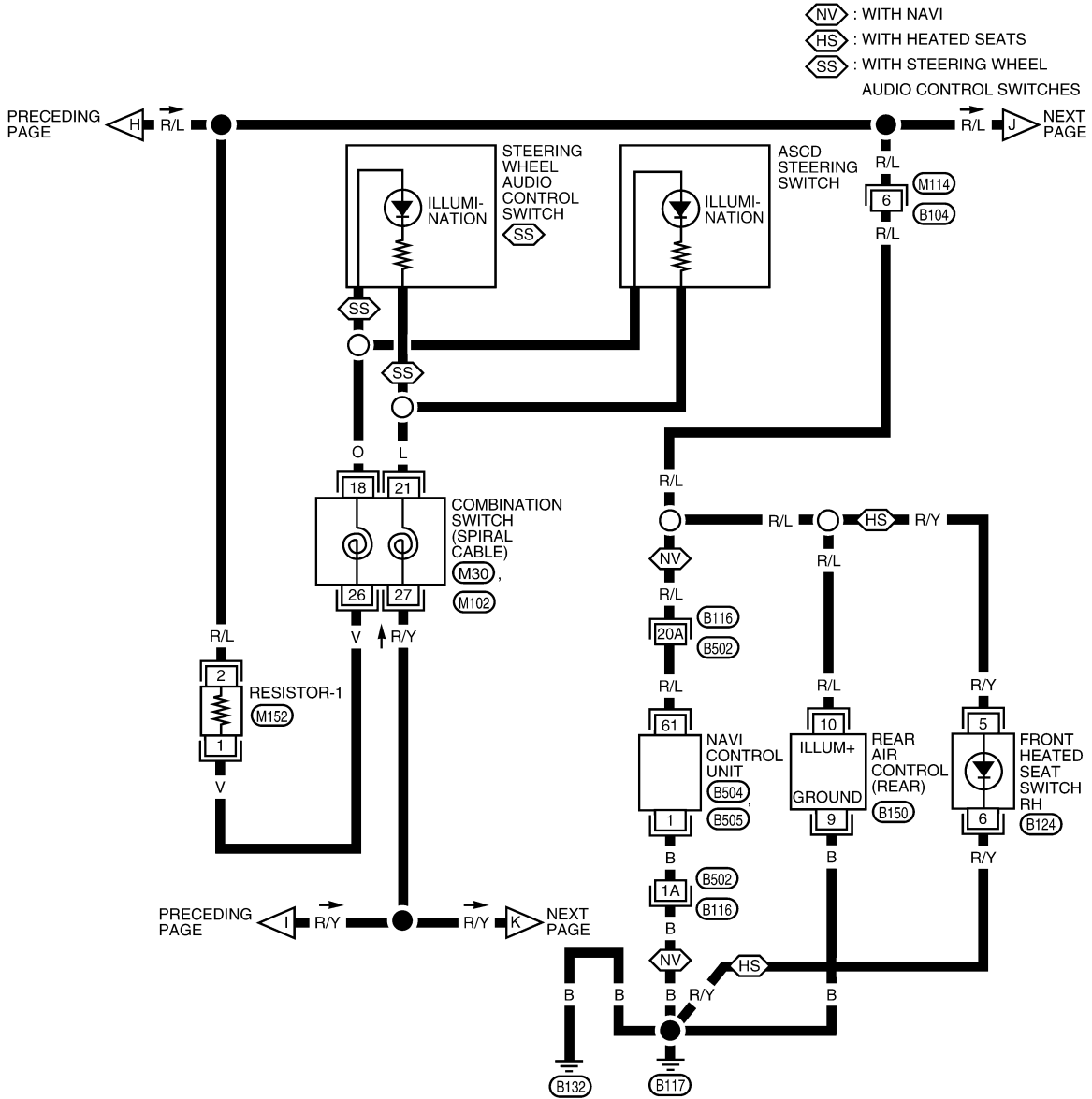

* : THIS CONNECTOR IS NOT SHOWN IN "HARNESS LAYOUT" OF PG SECTION.

ALLWA0144GB

ILLUMINATION

< SERVICE INFORMATION >

LT-ILL-07

- ⬡(BB) : WITH BLUETOOTH
- ⬡(RR) : WITH REAR AUDIO REMOTE CONTROL UNIT
- ⬡(WS) : WITH POWER SLIDING DOOR
- ⬡(XL) : WITHOUT POWER SLIDING DOOR

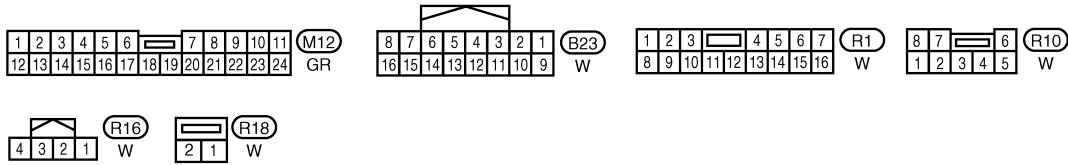
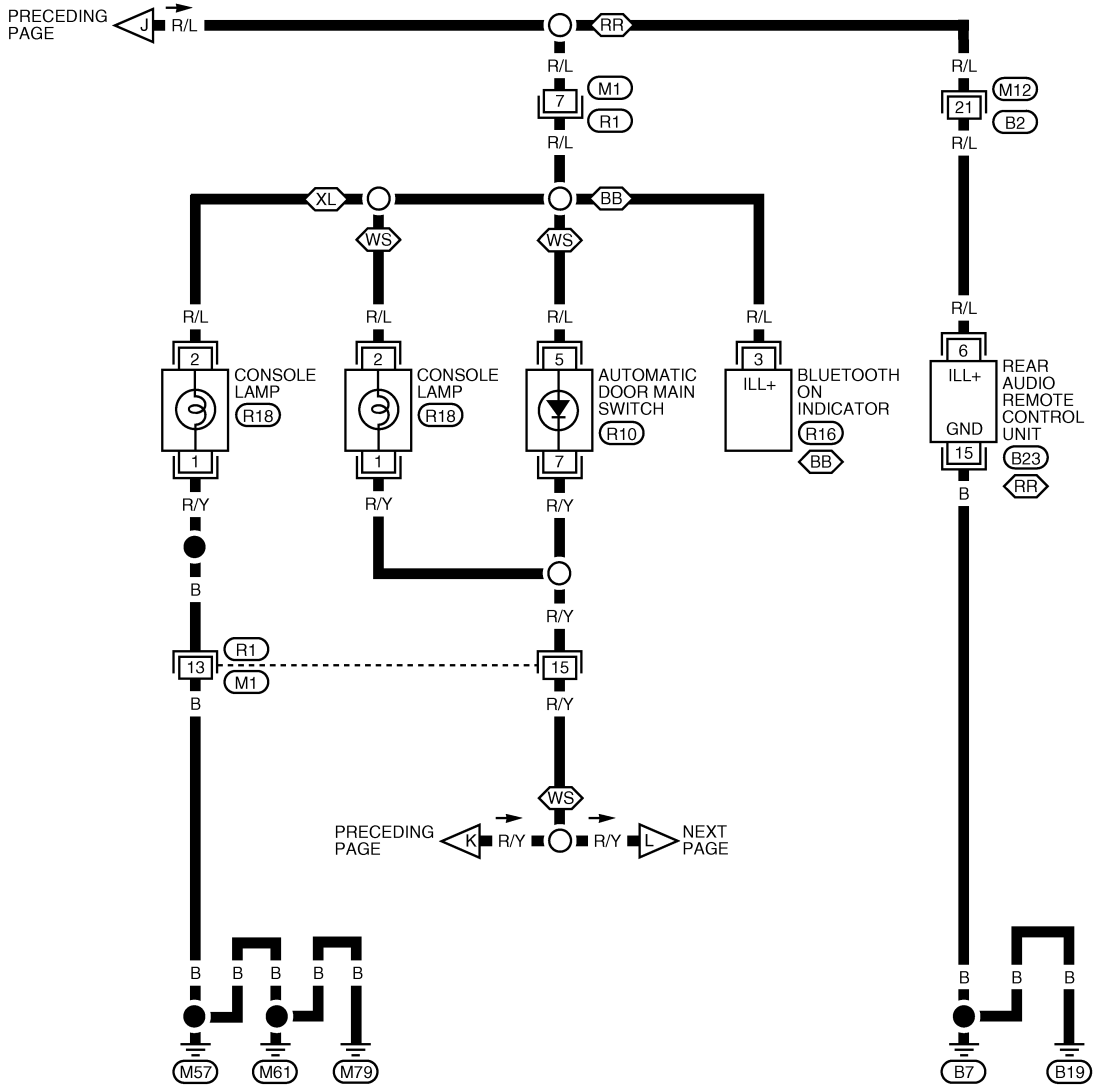

WKWA4730E

ILLUMINATION

< SERVICE INFORMATION >

LT-ILL-08

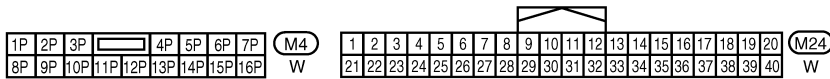
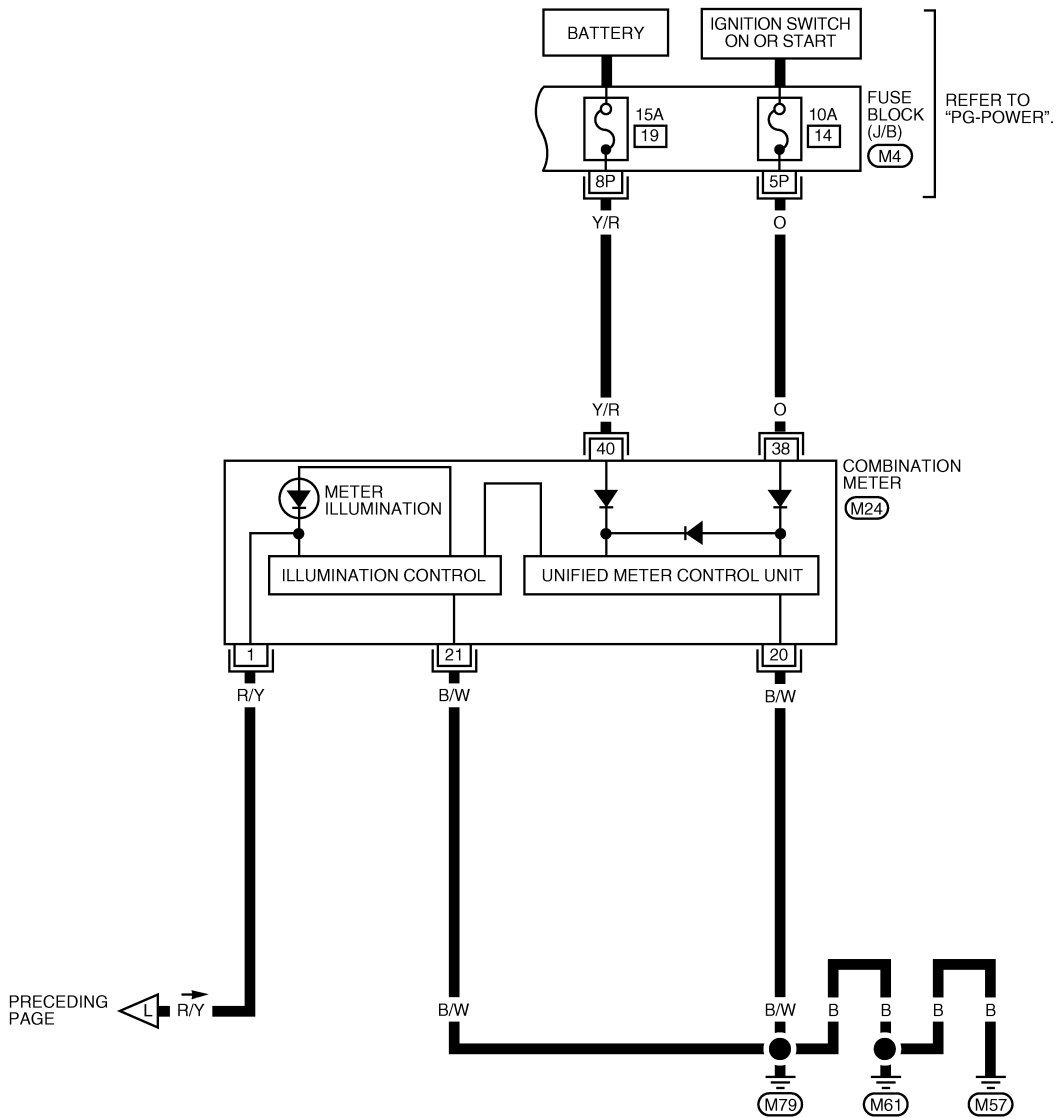

WKWA4731E

A
B
C
D
E
F
G
H
I
J
LT
L
M
N
O
P

BULB SPECIFICATIONS

< SERVICE INFORMATION >

BULB SPECIFICATIONS

Headlamp

INFOID:000000001719176

Item	Wattage (W)*
Low	51 (HB4)
High	60 (HB3)

*: Always check with the Parts Department for the latest parts information.

Exterior Lamp

INFOID:000000001719177

Item	Wattage (W)*	
Front combination lamp	Turn signal lamp/parking lamp	29/8
	Cornering lamp	27
Rear combination lamp	Stop/Tail lamp	27/7
	Turn signal lamp	27
	Back-up lamp	18
Fog lamp	55 (H11)	
License plate lamp	5	
High-mounted stop lamp	13	

*: Always check with the Parts Department for the latest parts information.

Interior Lamp/Illumination

INFOID:000000001719178

Item	Wattage (W)*
Glove box lamp	3.4
Ignition keyhole illumination lamp	0.74
Room/Map lamp	8
Console lamp	LED
A/T device lamp	3
Foot lamp	3.4
Step lamp	3.8
Cargo lamp	7
Vanity lamp	1.32
Personal lamp (with rear roof console assembly)	8
Personal lamp (without rear roof console assembly)	8
Running board lamp	3.4

*: Always check with the Parts Department for the latest parts information.