

A
FL
C
D
E
F
G
H
I
J
K
L
M
N
O
P

SECTION FL
FUEL SYSTEM

CONTENTS

PRECAUTION	2	Disassembly and Assembly	10
PRECAUTIONS	2	Inspection	10
General Precautions	2	FUEL TANK	12
PREPARATION	3	Exploded View	12
PREPARATION	3	Removal and Installation	13
Special Service Tool	3	Inspection	14
Commercial Service Tool	3	EVAP CANISTER	15
PERIODIC MAINTENANCE	4	Hydraulic Layout	15
FUEL SYSTEM	4	Exploded View	16
Inspection	4	Removal and Installation	16
Quick Connector	4	Disassembly and Assembly	16
REMOVAL AND INSTALLATION	5	Inspection	17
FUEL LEVEL SENSOR UNIT, FUEL FILTER		SERVICE DATA AND SPECIFICATIONS	
AND FUEL PUMP ASSEMBLY	5	(SDS)	18
Exploded View	5	SERVICE DATA AND SPECIFICATIONS	
Removal and Installation	5	(SDS)	18
		Fuel Tank	18

PRECAUTIONS

< PRECAUTION >

PRECAUTION

PRECAUTIONS

General Precautions

INFOID:000000007107227

WARNING:

When replacing fuel line parts, be sure to observe the following.

- Put a “CAUTION: FLAMMABLE” sign in the workshop.
- Be sure to work in a well ventilated area and furnish workshop with a CO2 fire extinguisher.
- Never smoke while servicing fuel system. Keep open flames and sparks away from the work area.

CAUTION:

- Use gasoline required by the regulations for octane number. Refer to [GI-28, "Fuel"](#).
- Before removing fuel line parts, perform out the following procedures:
 - Put drained fuel in an explosion-proof container and put the lid on securely. Keep the container in safe area.
 - Release fuel pressure from the fuel lines. Refer to [EC-136, "Work Procedure"](#).
 - Disconnect the battery cable from the negative terminal.
- Always replace O-ring and clamps with new ones.
- Never kink or twist tubes when they are being installed.
- Never tighten hose clamps excessively to avoid damaging hoses.
- After installing tubes, check there is no fuel leakage at connections in the following steps.
 - Apply fuel pressure to fuel lines with turning ignition switch “ON” (with engine stopped). Then check for fuel leakage at connections.
 - Start engine and rev it up and check for fuel leakage at connections.
- Use only a genuine NISSAN fuel filler cap as a replacement. If an incorrect fuel filler cap is used, the “MIL” may come on.
- For servicing “On Board Refueling Vapor Recovery (ORVR)” parts, refer to [EC-55, "Diagnosis Description"](#).

PREPARATION

< PREPARATION >

PREPARATION

PREPARATION

Special Service Tool

INFOID:000000007835549

A

FL

The actual shapes of Kent-Moore tools may differ from those of special service tools illustrated here.

Tool number (Kent-Moore No.) Tool name	Description
KV10119901 (—) Fuel tank lock ring wrench	Removing and installing fuel tank retainer
— (J-45747) Fuel tank lock ring wrench	Removing and installing fuel tank retainer

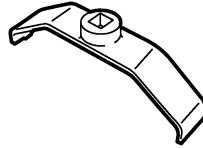

JPBIA3555ZZ

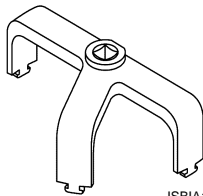

JSBIA1952ZZ

C

D

E

F

G

H

Commercial Service Tool

INFOID:000000007107229

Tool name	Description
Power tool	Loosening nuts and bolts

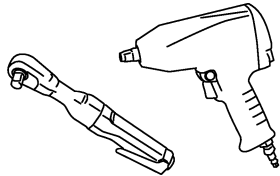

PBIC0190E

I

J

K

L

M

N

O

P

FUEL SYSTEM

< PERIODIC MAINTENANCE >

PERIODIC MAINTENANCE

FUEL SYSTEM

Inspection

INFOID:000000007107230

Inspect fuel lines, fuel filler cap, and fuel tank for improper attachment, leakage, cracks, damage, loose connections, chafing or deterioration.

- A : Engine
- B : Fuel line
- C : Fuel tank

If necessary, repair or replace damaged parts.

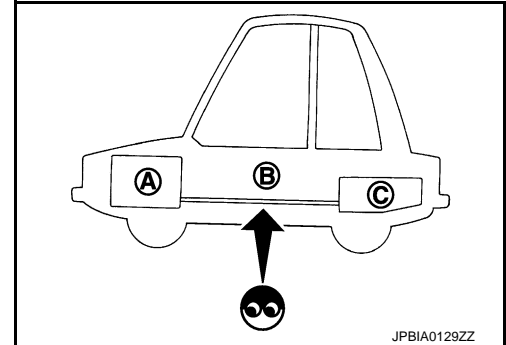

Quick Connector

INFOID:000000007107231

CAUTION:

- After connecting fuel tube quick connectors, check quick connectors are secure.

- 1 : Quick connector
- 2 : Retainer
- A : Hard tube (or the equivalent)
- B : Connection (cross-section)
- C : Resin tube
- D : To under floor fuel line
- E : To fuel tank
- F : Tab
- G : Disconnection

- Ensure that connector and resin tube never contact any adjacent parts.

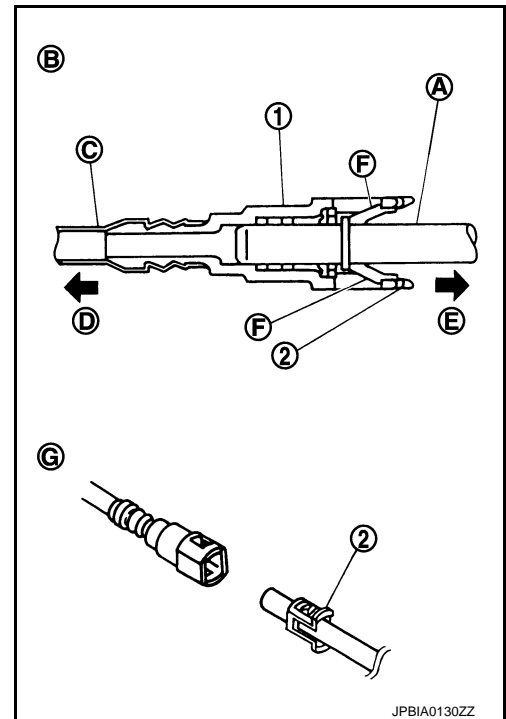

FUEL LEVEL SENSOR UNIT, FUEL FILTER AND FUEL PUMP ASSEMBLY

< REMOVAL AND INSTALLATION >

REMOVAL AND INSTALLATION

FUEL LEVEL SENSOR UNIT, FUEL FILTER AND FUEL PUMP ASSEMBLY

Exploded View

INFOID:000000007107232

A

FL

REMOVAL

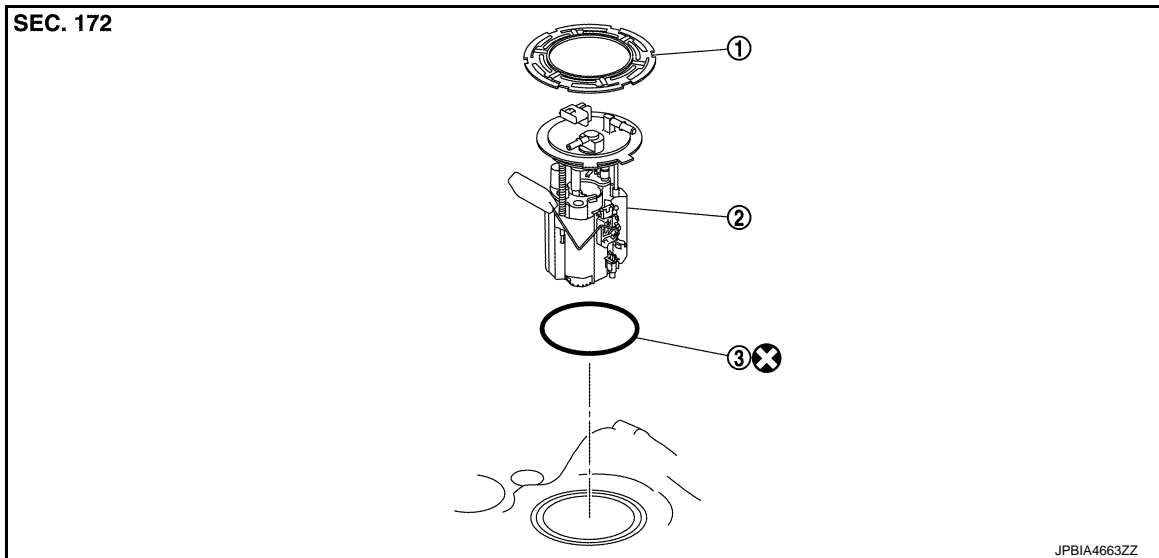

1. Retainer

2. Fuel level sensor unit, fuel filter and fuel pump assembly

3. Seal packing

⊗ : Always replace after every disassembly.

DISASSEMBLY

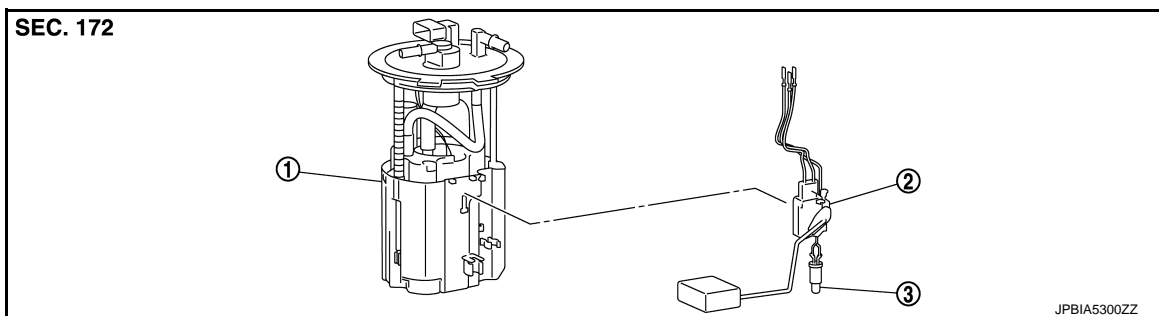

1. Fuel filter and fuel pump assembly

2. Fuel level sensor unit

3. Fuel tank temperature sensor

Removal and Installation

INFOID:000000007835550

WARNING:

Read "General Precautions" when working on the fuel system. Refer to [GI-24, "General Precautions"](#).

REMOVAL

1. Release the fuel pressure from the fuel lines. Refer to [EC-136, "Work Procedure"](#).
2. Check fuel level on a level ground. If the fuel level is 7/8 of the fuel tank (full or nearly full), draw appropriate amount of fuel from the fuel tank.

Guideline : Draw approximately 20 liters from a full-tank condition.

- In the event of malfunction in fuel pump, insert a hose measuring 20mm (0.79 in) in diameter into the filler opening to draw approximately 20 liters fuel.

C

D

E

F

G

H

I

J

K

L

M

N

O

P

FUEL LEVEL SENSOR UNIT, FUEL FILTER AND FUEL PUMP ASSEMBLY

< REMOVAL AND INSTALLATION >

3. Open fuel filler lid.
4. Open filler cap and release the pressure inside fuel tank.
5. Slide the left second seat in the forward direction.
6. Peel off floor carpet, then remove inspection hole cover units by turning clips clockwise by 90 degrees.
7. Disconnect harness connector (1), fuel feed tube (3) and EVAP hose (2).

4 : Quick connector

⇐ : Vehicle front

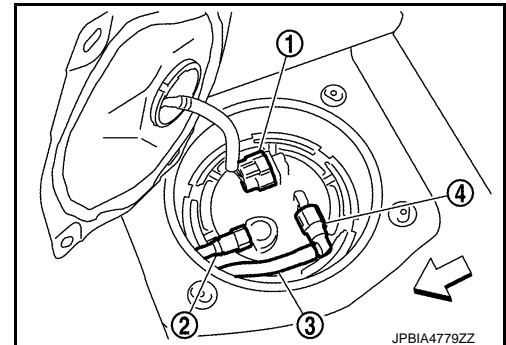

Disconnect quick connector as follows:

- Hold the sides of connector, push in tabs (B) and pull out fuel feed tube.

A : Pull

- If quick connector sticks to tube of main fuel level sensor unit, push and pull quick connector several times until they start to move. Then disconnect them by pulling.

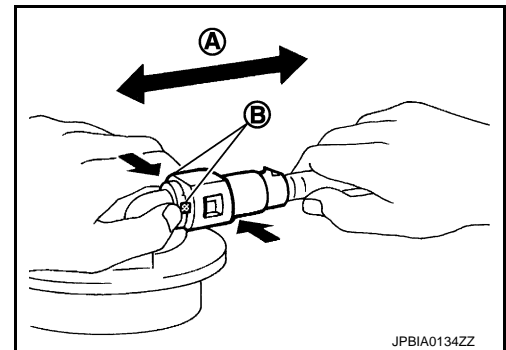

CAUTION:

- Quick connector (1) can be disconnected when the tabs (F) are completely depressed. Never twist it more than necessary.

B : Connection (cross-section)

D : To under floor fuel line

E : To fuel tank

G : Disconnection

- Never use any tools to disconnected quick connector.
- Keep resin tube (C) away from heat. Be especially careful when welding near the resin tube.
- Prevent acid liquid such as battery electrolyte, etc. from getting on resin tube.
- Never bend or twist resin tube during installation and disconnection.
- Never remove the remaining retainer (2) on hard tube (or the equivalent) (A) except when resin tube or retainer is replaced.
- When resin tube or hard tube (or the equivalent) is replaced, also replace retainer with new one.

Retainer color: Green

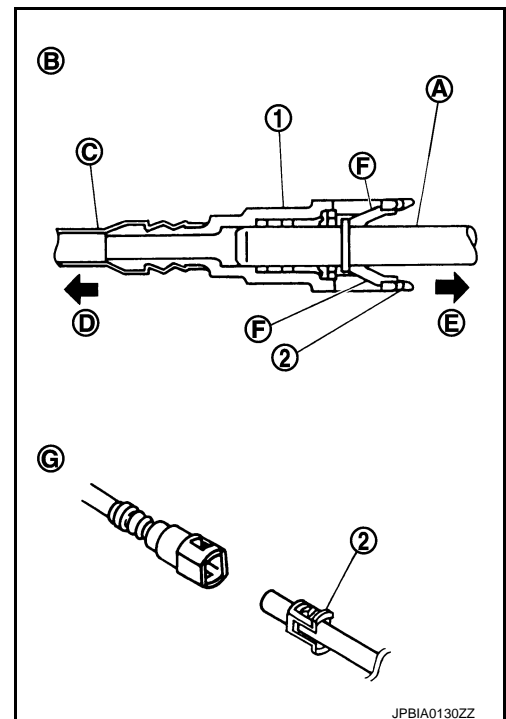

FUEL LEVEL SENSOR UNIT, FUEL FILTER AND FUEL PUMP ASSEMBLY

< REMOVAL AND INSTALLATION >

- To keep the connecting portion clean and to avoid damage and foreign materials, cover them completely with plastic bags (A) or something similar.

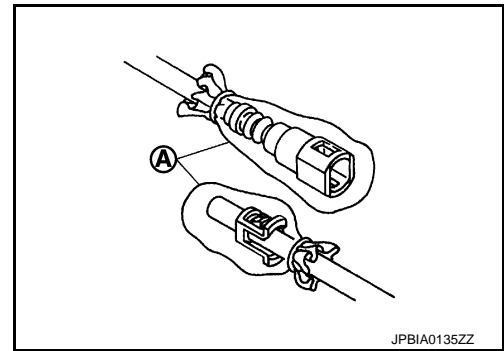

8. Remove retainer for fuel level sensor unit, fuel filter and fuel pump assembly with fuel tank lock ring wrench [SST: KV10119901 (-)] (A) by turning counterclockwise.

CAUTION:

- To prevent lock ring wrench from being detached, securely hold down spinner handle (B) by hand.
- To reduce impact caused by removal operation, use long spinner handle [handle length: 60 cm (23.62 in) or more] and slowly turn it counterclockwise.

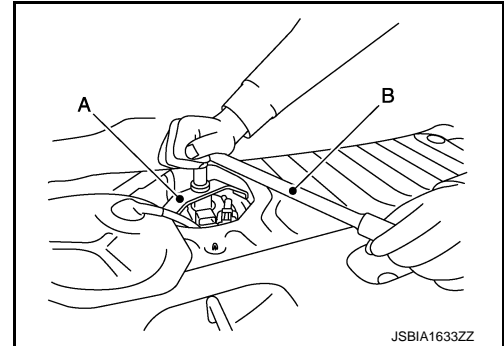

9. Pull up the fuel level sensor unit, fuel filter and fuel pump assembly to the position shown in the figure.

CAUTION:

- To prevent the transfer tube from becoming disconnected, never pull the assembly more than necessary.

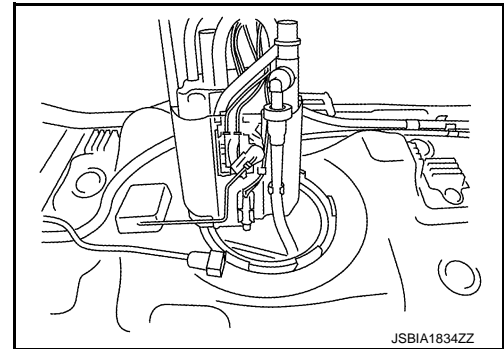

10. Disconnect transfer tube from the fuel level sensor unit, fuel filter and fuel pump assembly by holding and pulling (A) of quick connector in the direction shown by arrow.

CAUTION:

- Never pull transfer tube because it is inseparable from the fuel tank assembly.

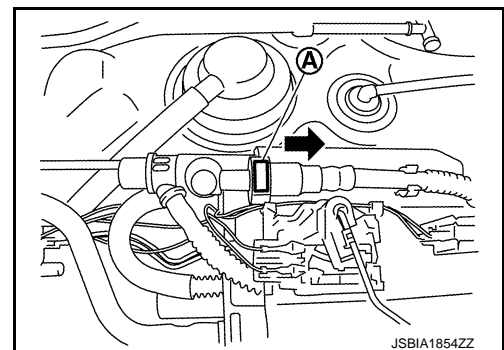

11. Remove fuel level sensor unit, fuel filter and fuel pump assembly.

INSTALLATION

Note to the following, and install in the reverse order of removal.

Fuel Level Sensor Unit

1. Install new seal packing to fuel tank without any twist.

A
FL
C
D
E
F
G
H
I
J
K
L
M
N
O
P

FUEL LEVEL SENSOR UNIT, FUEL FILTER AND FUEL PUMP ASSEMBLY

< REMOVAL AND INSTALLATION >

2. Disconnect transfer tube placed in the fuel tank quick connector as follows.
 1. Check the connection for damage or any foreign materials.
 2. Eliminate distortion from the transfer tube placed in the fuel tank, referring to the figure.
 3. Align the connector with the tube, then insert the connector straight into the tube until a click sound is heard.
 4. Pull the tube and the connector to check they are securely connected.

↔ :Vehicle front

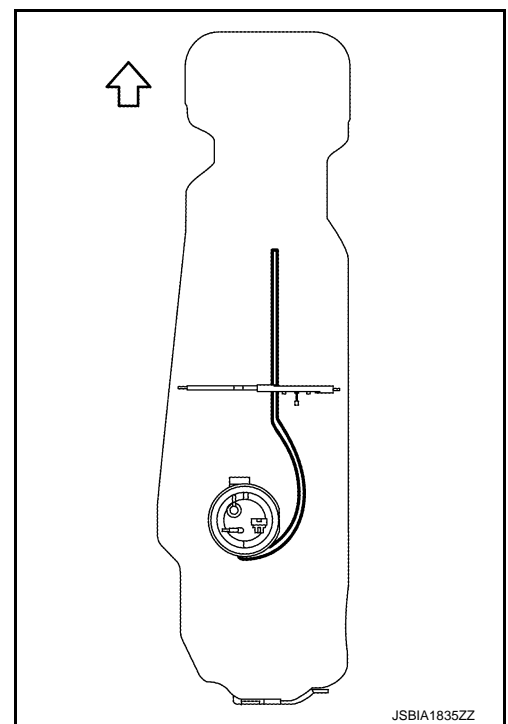

3. With the float of fuel level sensor unit, fuel filter and fuel pump assembly positioned as shown in the figure, insert the fuel level sensor unit, fuel filter and fuel pump assembly into the fuel tank.

↔ :Vehicle front

CAUTION:
Never bend float arm during installing.

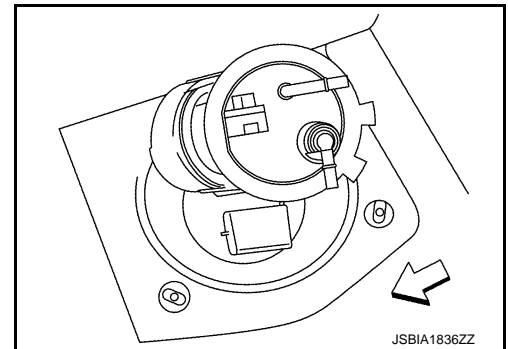

4. After the insertion, turn the fuel level sensor unit, fuel filter and fuel pump assembly by 90 degrees in the direction shown by arrow.

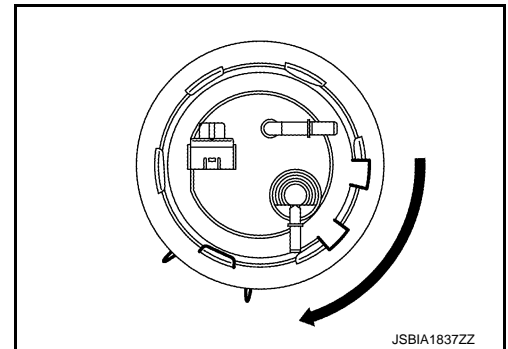

FUEL LEVEL SENSOR UNIT, FUEL FILTER AND FUEL PUMP ASSEMBLY

< REMOVAL AND INSTALLATION >

5. Through the opening of the fuel tank, check that the transfer hose is placed as shown in the figure.

CAUTION:

Check that the transfer tube does not interfere with the float and the float arm.

← :Vehicle front

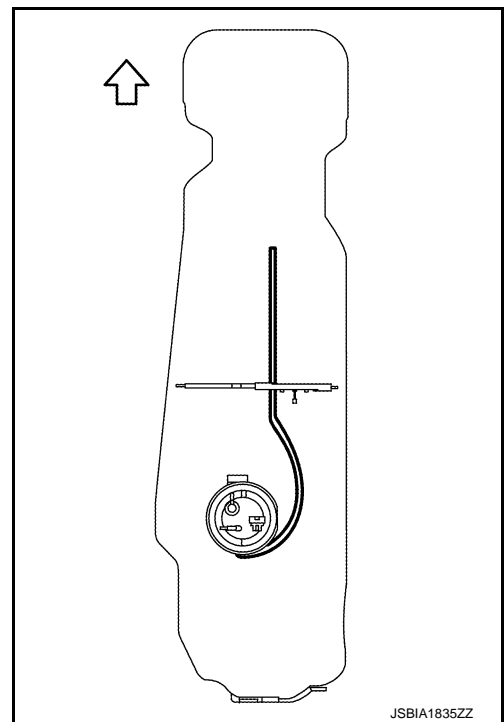

6. Align protrusion (A) of fuel level sensor unit, fuel filter and fuel pump assembly with matching mark (C) of fuel tank to install the fuel level sensor unit, fuel filter and fuel pump assembly.

B :Retainer mounting pawl

CAUTION:

- Never allow seal packing to drop.
- Never bend float arm during installing.

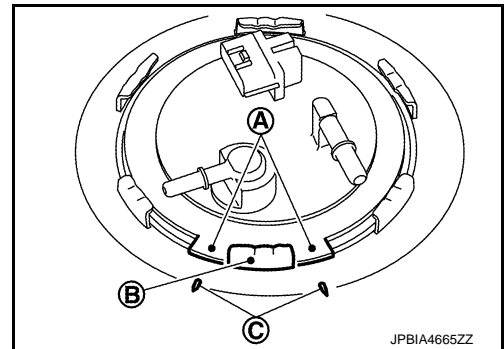

7. Tighten retainer with a lock ring wrench [SST: KV10119901 (-)].
- When tightening retainer, horizontally press lock ring wrench to protect retainer from tilting.
 - Tighten retainer until protrusion (B) of retainer overlaps retainer mounting pawl (A).
 - If it is hard to tighten retainer, recheck retainer. Refer to [FL-10, "Inspection"](#).

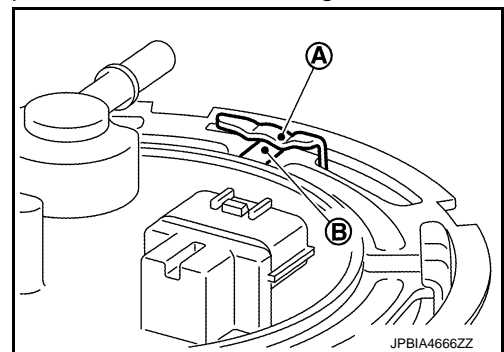

Quick Connector

Connect quick connector as follows:

1. Check the connection for damage or any foreign materials.
2. Align the connector with the tube, then insert the connector straight into the tube until a click sound is heard.
3. After connecting, check that the connection is secure by following method.

FUEL LEVEL SENSOR UNIT, FUEL FILTER AND FUEL PUMP ASSEMBLY

< REMOVAL AND INSTALLATION >

- Pull (A) the tube and the connector to check they are securely connected.
- Visually confirm that the two retainer tabs are connected to the connector.

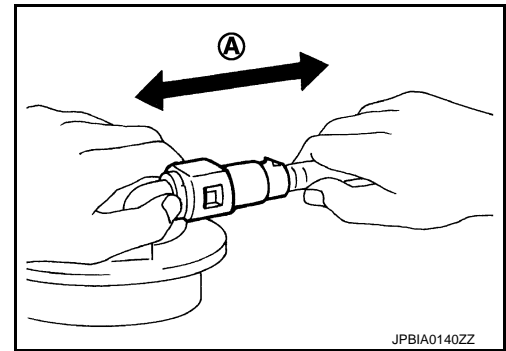

Disassembly and Assembly

INFOID:000000007107234

DISASSEMBLY

1. Disconnect harness connector (A).
 - Press into the pawl (←) of the mounting area to pull out connector.

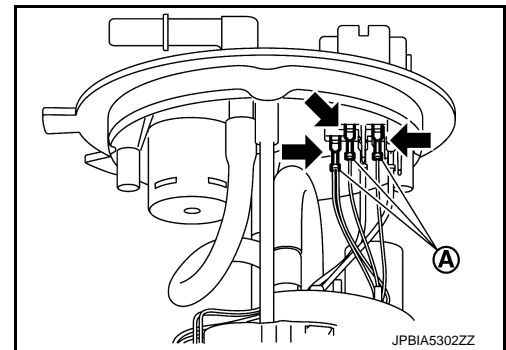

2. Remove fuel level sensor unit (1) from fuel filter and fuel pump assembly (2), according to the following steps.
 - a. Press into pawl (A) of fuel level sensor mounting area.
 - b. With the fuel level sensor unit unlocked, slide it in the direction shown by the arrow (←).

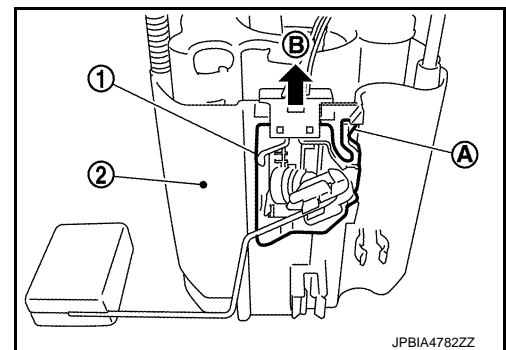

ASSEMBLY

1. Install fuel level sensor unit
 - Install fuel level sensor all the way. Tactually and aurally check the fit.
2. Connect harness connector.
 - Connect harnesses [(A): red, (B): white, (C): black] as shown in the figure.

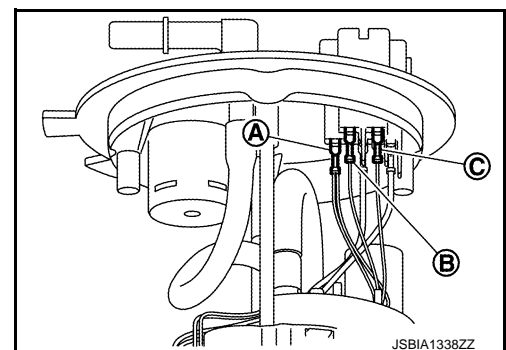

Inspection

INFOID:000000007107235

INSPECTION AFTER INSTALLATION

FUEL LEVEL SENSOR UNIT, FUEL FILTER AND FUEL PUMP ASSEMBLY

< REMOVAL AND INSTALLATION >

Retainer

Check retainer (1), according to the following steps.

- Visually check that slot (B) of retainer and its surrounding parts (6 points) are free from protrusions (e.g. burr).
- If the slot and its surrounding parts have protrusions, replace retainer with a new one.

NOTE:

The inside of the slot includes locating protrusion (A) (one for each slot) used for the fit between retainer and retainer mounting pawl.

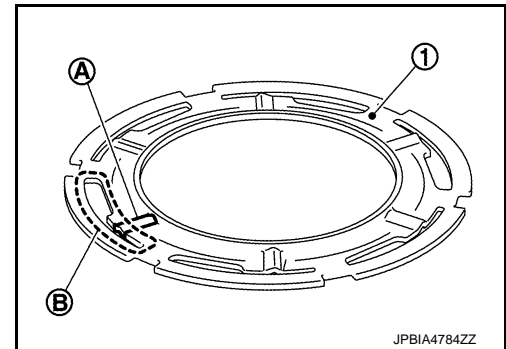

Fuel leakage

Use the following procedure to check for fuel .

1. Turn ignition switch "ON" (with engine stopped), then check connections for leakage by applying fuel pressure to fuel piping.
2. Start engine and let it idle and check there are no fuel leakage at the fuel system connections.

A

FL

C

D

E

F

G

H

I

J

K

L

M

N

O

P

FUEL TANK

< REMOVAL AND INSTALLATION >

FUEL TANK

Exploded View

INFOID:000000007107236

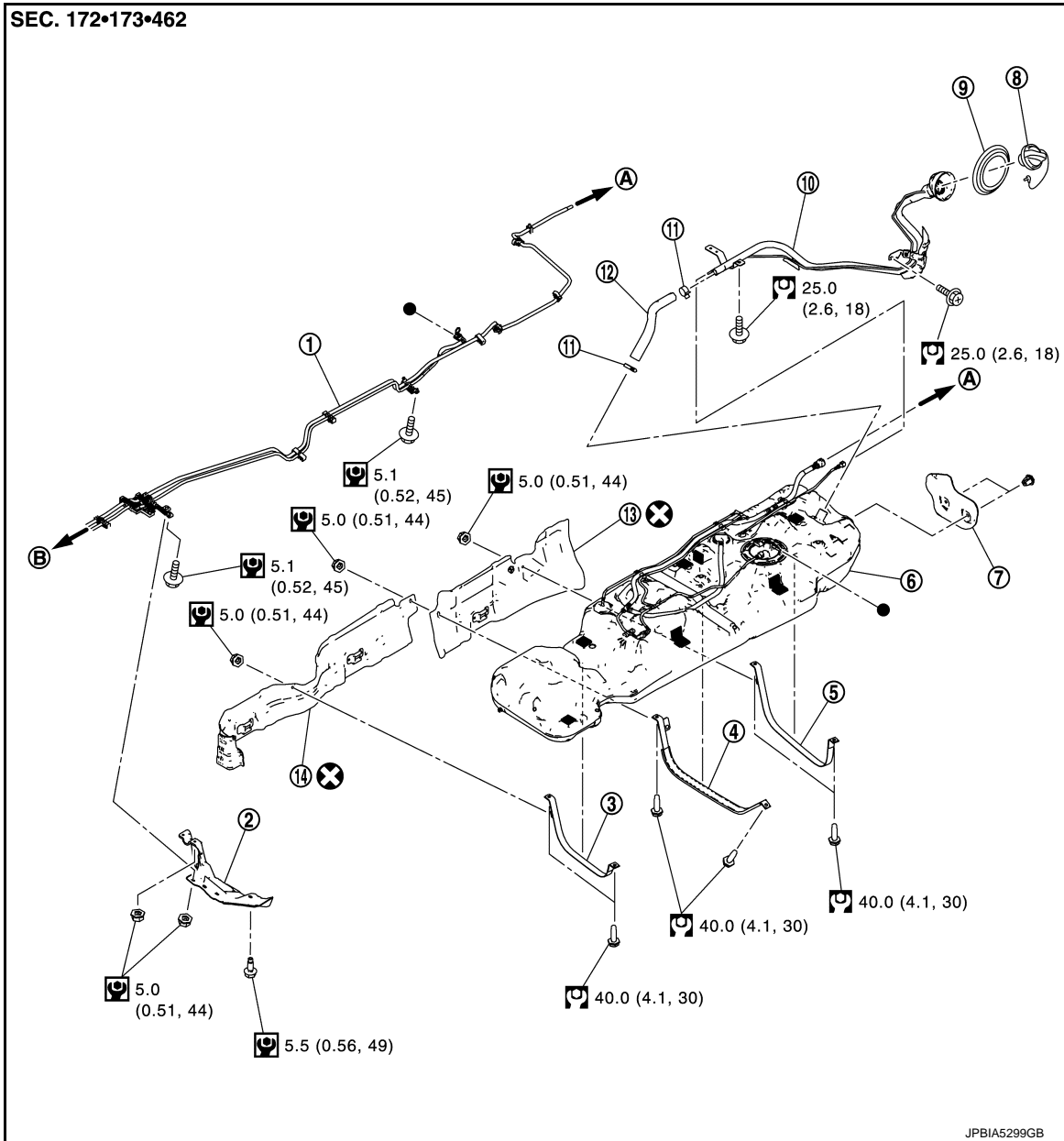

- | | | |
|------------------------------|------------------------------|------------------------------|
| 1. EVAP/Vent line tube | 2. Fuel tank protector 1 | 3. Fuel tank mounting band 1 |
| 4. Fuel tank mounting band 2 | 5. Fuel tank mounting band 3 | 6. Fuel tank |
| 7. Fuel tank protector 4 | 8. Fuel filler cap | 9. Grommet |
| 10. Fuel filler tube | 11. Clamp | 12. Fuel filler hose |
| 13. Fuel tank protector 3 | 14. Fuel tank protector 2 | |
| A. To EVAP canister | B. To engine | |

⊗: Always replace after every disassembly.

⊞: N-m (kg-m, ft-lb)

⊞: N-m (kg-m, in-lb)

FUEL TANK

< REMOVAL AND INSTALLATION >

Removal and Installation

INFOID:000000007107237

WARNING:

Be sure to read “General Precautions” when working on the fuel system. Refer to [FL-2, "General Precautions"](#).

REMOVAL

- Drain fuel from fuel tank if necessary. Refer to [FL-5, "Removal and Installation"](#).
 - Perform work on level place.
1. Perform steps 1 to 7 of “REMOVAL” in “ FUEL LEVEL SENSOR UNIT, FUEL FILTER AND FUEL PUMP ASSEMBLY” on main and sub fuel level sensor units. Refer to [FL-5, "Removal and Installation"](#).
 2. Remove fuel tank protector 1.
 3. Disconnect fuel filler hose, EVAP/Vent line hose connector, and EVAP (Recirculation) hose connector from the side other than the fuel tank side (←).

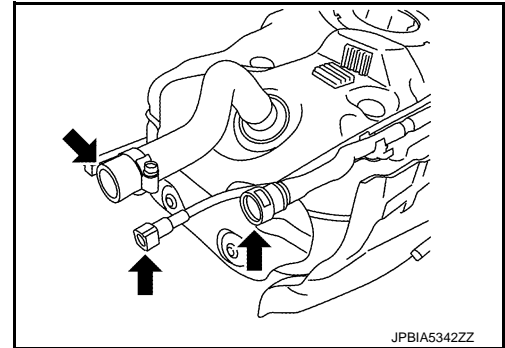

4. Support the lower part of fuel tank (1) with transmission jacks (A).

CAUTION:

- Securely support the flat bottom face.
- Horizontally support the fuel tank by using two mission jacks.
- Support the position that fuel tank mounting bands never engage.

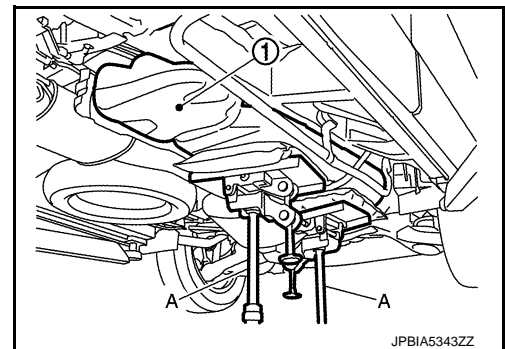

5. Remove fuel tank mounting bands.
6. Supporting with hands, descend transmission jack carefully, and remove fuel tank.
CAUTION:
 - Check that all connection points have been disconnected.
 - Confirm there is no interference with vehicle.
7. Remove fuel tank protector 2, 3 and 4.
CAUTION:
Fuel tank protector 2 and 3 are not reusable. Never remove them unless it is necessary.
8. When removing fuel filler tube, slide rear suspension member assembly downward, according to the following instructions. Refer to [RSU-19, "Removal and Installation"](#).
 1. Fix the bottom face of the rear final drive assembly with a mission jack.
 2. Remove rear suspension member mounting nut, and carefully lower the jack to the position close to the height that rear suspension member becomes almost detached from the stud.

INSTALLATION

Note the following, and install in the reverse order of removal.

- Surely clamp fuel hoses and insert hose to the length below.

Fuel filler hose : 35 mm (1.38 in)

- Be sure hose clamp is not placed on swelled area of fuel tube.

FUEL TANK

< REMOVAL AND INSTALLATION >

- Tighten the clamp hand with the top mark (A) until the mark is on the bolt head flange.

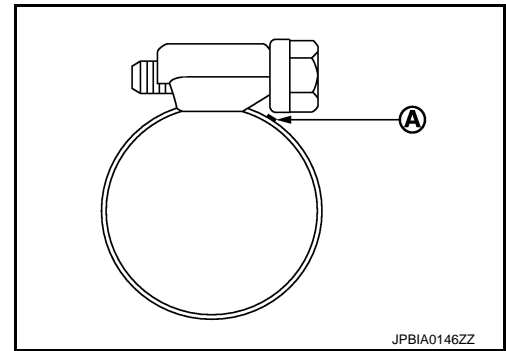

- To connect quick connector, refer to [FL-5. "Removal and Installation"](#).
- Tighten mounting band, according to the order shown in the figure.
- To install fuel tank protectors, install fuel tank to the vehicle first.

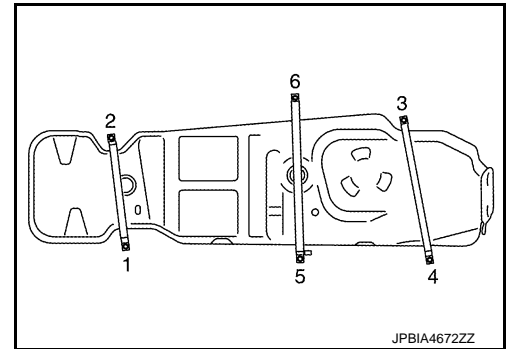

Inspection

INFOID:000000007107238

INSPECTION AFTER INSTALLATION

Use the following procedure to check for fuel leakage.

1. Turn ignition switch "ON" (with engine stopped), and check connections for leakage by applying fuel pressure to fuel piping.
 2. Start engine and rev it up and check there are no fuel leakage at the fuel system tube and hose connections.
- After removing/installing rear suspension assembly, check to adjust wheel alignment and then, adjust neutral position of steering angle sensor. Refer to [RSU-20. "Inspection"](#) and [BRC-48. "Work Procedure"](#).

EVAP CANISTER

< REMOVAL AND INSTALLATION >

EVAP CANISTER

Hydraulic Layout

INFOID:000000007107246

EVAPORATIVE EMISSION LINE DRAWING

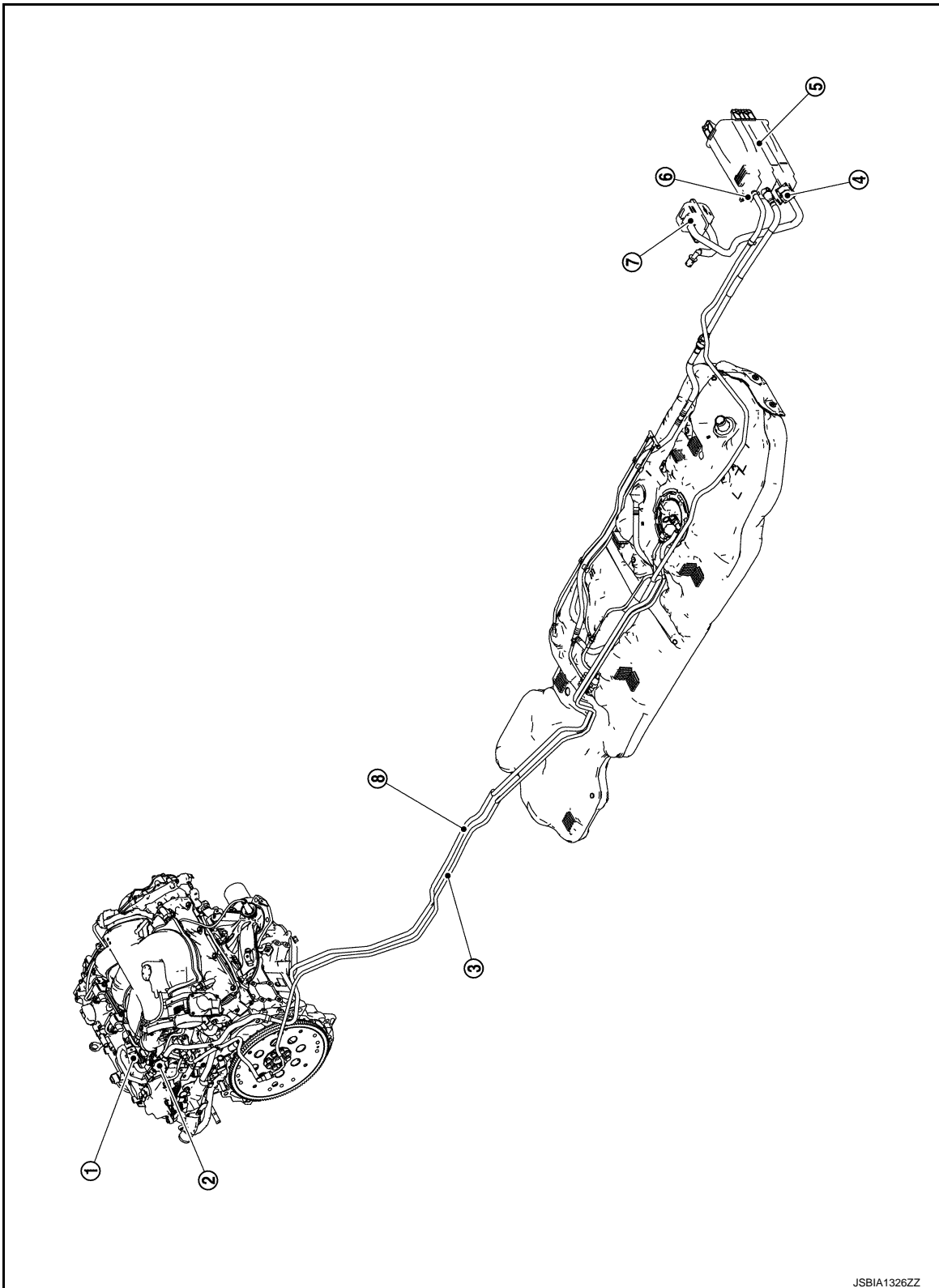

JSBIA1326ZZ

A

FL

C

D

E

F

G

H

I

J

K

L

M

N

O

P

EVAP CANISTER

< REMOVAL AND INSTALLATION >

- | | | |
|--|----------------------|---------------------------------|
| 1. EVAP canister purge volume control solenoid valve | 2. EVAP service port | 3. Fuel line |
| 4. EVAP canister vent control valve | 5. EVAP canister | 6. EVAP control pressure sensor |
| 7. Canister filter | 8. EAVP line | |

NOTE:

Do not use soapy water or any type of solvent while installing vacuum hose or purge hoses.

Exploded View

INFOID:000000007107247

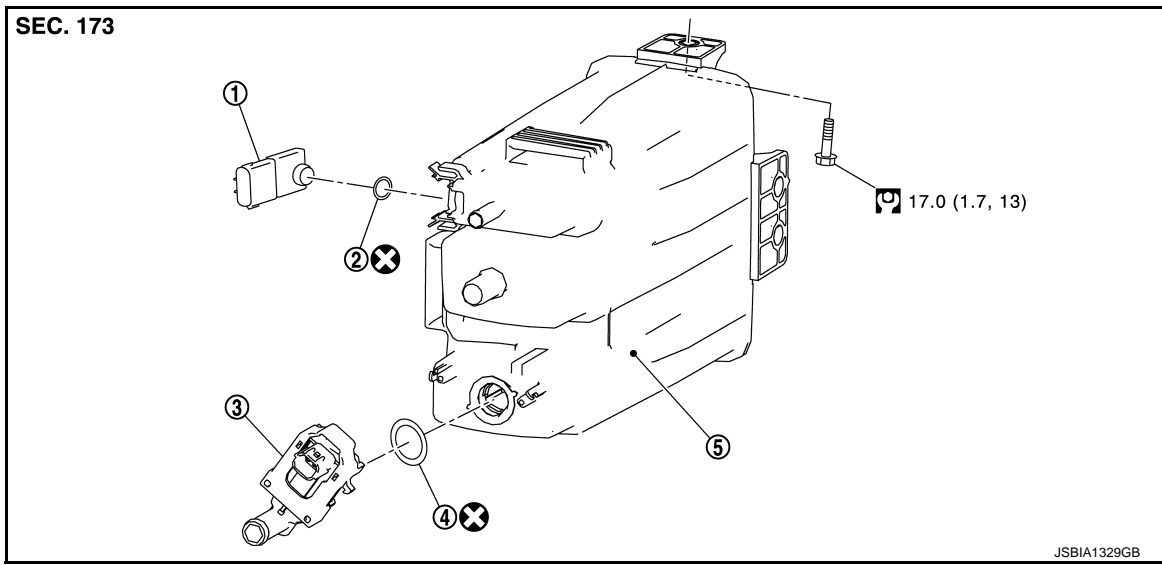

- | | | |
|---------------------------------|------------------|-------------------------------------|
| 1. EVAP control pressure sensor | 2. O-ring | 3. EVAP canister vent control valve |
| 4. O-ring | 5. EVAP canister | |

: N·m (kg·m, ft·lb)

: Always replace after every disassembly.

Removal and Installation

INFOID:000000007107248

REMOVAL

1. Disconnect harness connectors (EVAP control pressure sensor and EVAP canister vent control valve) and EVAP canister hoses.
2. Remove EVAP canister fixing bolt.
3. Remove EVAP canister.

NOTE:

EVAP canister vent control valve and EVAP control pressure sensor can be removed without removing the EVAP canister.

INSTALLATION

Install in the reverse order of removal.

NOTE:

Tighten EVAP canister fixing bolt to the specified torque.

Disassembly and Assembly

INFOID:000000007107249

DISASSEMBLY

EVAP CANISTER

< REMOVAL AND INSTALLATION >

1. Disengage the pawl and turn EVAP canister vent control valve counterclockwise.
2. Remove the EVAP canister vent control valve.
3. Remove EVAP control pressure sensor.

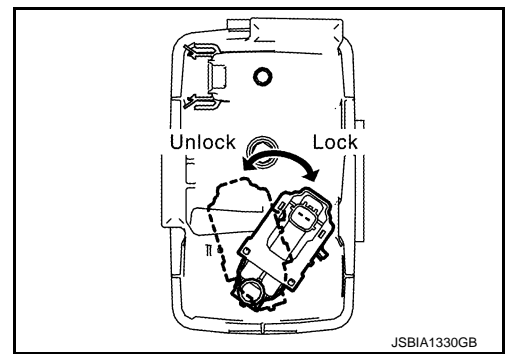

ASSEMBLY

Assemble in the reverse order of disassembly.

CAUTION:

Always replace O-ring with a new one.

Inspection

INFOID:000000007107250

Check EVAP canister as per the following:

1. Block port (B).
2. Blow air into port (A) and check that it flows freely out of port (C).
3. Release blocked port (B).
4. Apply vacuum pressure to port (B) and check that vacuum pressure exists at the ports (A) and (C).
5. Block port (A) and (B).
6. Apply pressure to port (C) and check that there is no leakage.

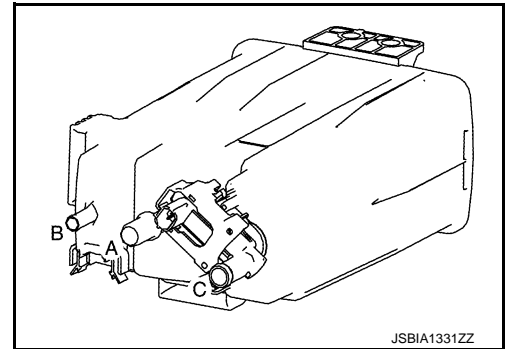

A

FL

C

D

E

F

G

H

I

J

K

L

M

N

O

P

SERVICE DATA AND SPECIFICATIONS (SDS)

< SERVICE DATA AND SPECIFICATIONS (SDS)

SERVICE DATA AND SPECIFICATIONS (SDS)

SERVICE DATA AND SPECIFICATIONS (SDS)

Fuel Tank

INFOID:000000007107242

Standard and Limit

Fuel tank capacity	Approx. 75.6 ℓ (20 US gal, 16-5/8 Imp gal)
Fuel recommendation	Refer to GI-28