

SECTION **PCS**

POWER CONTROL SYSTEM

A
B
C
D
E
F
G
H
I
J
K
L
N
O
P

CONTENTS

IPDM E/R	Fail-safe	23
PRECAUTION	DTC Index	24
PRECAUTIONS	WIRING DIAGRAM	26
Precaution for Supplemental Restraint System (SRS) "AIR BAG" and "SEAT BELT PRE-TENSIONER"	IPDM E/R	26
	Wiring Diagram	26
SYSTEM DESCRIPTION	DTC/CIRCUIT DIAGNOSIS	30
COMPONENT PARTS	U1000 CAN COMM CIRCUIT	30
IPDM E/R	Description	30
IPDM E/R : Component Parts Location	DTC Logic	30
SYSTEM	Diagnosis Procedure	30
RELAY CONTROL SYSTEM	B2098 IGNITION RELAY ON STUCK	31
RELAY CONTROL SYSTEM : System Description	Description	31
RELAY CONTROL SYSTEM : Fail-safe	DTC Logic	31
POWER CONTROL SYSTEM	Diagnosis Procedure	31
POWER CONTROL SYSTEM : System Description	B2099 IGNITION RELAY OFF STUCK	32
SIGNAL BUFFER SYSTEM	Description	32
SIGNAL BUFFER SYSTEM : System Description	DTC Logic	32
POWER CONSUMPTION CONTROL SYSTEM	Diagnosis Procedure	32
POWER CONSUMPTION CONTROL SYSTEM : System Diagram	POWER SUPPLY AND GROUND CIRCUIT	33
POWER CONSUMPTION CONTROL SYSTEM : System Description	Diagnosis Procedure	33
DIAGNOSIS SYSTEM (IPDM E/R)	REMOVAL AND INSTALLATION	34
Diagnosis Description	IPDM E/R	34
CONSULT Function (IPDM E/R)	Exploded View	34
ECU DIAGNOSIS INFORMATION	Removal and Installation	34
IPDM E/R	POWER DISTRIBUTION SYSTEM	
Reference Value	PRECAUTION	35
	PRECAUTIONS	35
	Precaution for Supplemental Restraint System (SRS) "AIR BAG" and "SEAT BELT PRE-TENSIONER"	35
	SYSTEM DESCRIPTION	36

PCS

COMPONENT PARTS	36	DTC Logic	59
Component Parts Location	36	Diagnosis Procedure	59
SYSTEM	37	Component Inspection	60
POWER DISTRIBUTION SYSTEM	37	B2618 BCM	61
POWER DISTRIBUTION SYSTEM : System De- scription	37	DTC Logic	61
Fail-safe	38	Diagnosis Procedure	61
DIAGNOSIS SYSTEM (BCM)	39	B261A PUSH-BUTTON IGNITION SWITCH	63
COMMON ITEM	39	DTC Logic	63
COMMON ITEM : CONSULT Function (BCM - COMMON ITEM)	39	Diagnosis Procedure	63
INTELLIGENT KEY	40	B26F1 IGNITION RELAY	65
INTELLIGENT KEY : CONSULT Function (BCM - INTELLIGENT KEY)	41	DTC Logic	65
ECU DIAGNOSIS INFORMATION	45	Diagnosis Procedure	65
BCM	45	B26F2 IGNITION RELAY	66
List of ECU Reference	45	DTC Logic	66
WIRING DIAGRAM	46	Diagnosis Procedure	66
POWER DISTRIBUTION SYSTEM	46	B26F6 BCM	68
Wiring Diagram	46	DTC Logic	68
BASIC INSPECTION	52	Diagnosis Procedure	68
DIAGNOSIS AND REPAIR WORK FLOW	52	PUSH-BUTTON IGNITION SWITCH	69
Work Flow	52	Component Function Check	69
DTC/CIRCUIT DIAGNOSIS	55	Diagnosis Procedure	69
B2614 ACC RELAY CIRCUIT	55	Component Inspection	70
DTC Logic	55	PUSH-BUTTON IGNITION SWITCH POSI- TION INDICATOR	72
Diagnosis Procedure	55	Description	72
Component Inspection	56	Component Function Check	72
B2615 BLOWER RELAY CIRCUIT	57	Diagnosis Procedure	72
DTC Logic	57	SYMPTOM DIAGNOSIS	74
Diagnosis Procedure	57	PUSH-BUTTON IGNITION SWITCH DOES NOT OPERATE	74
Component Inspection	58	Description	74
B2616 IGNITION RELAY CIRCUIT	59	Diagnosis Procedure	74
		PUSH-BUTTON IGNITION SWITCH POSI- TION INDICATOR DOES NOT ILLUMINATE ...	75
		Description	75
		Diagnosis Procedure	75

PRECAUTION

PRECAUTIONS

Precaution for Supplemental Restraint System (SRS) "AIR BAG" and "SEAT BELT PRE-TENSIONER"

INFOID:000000007094048

The Supplemental Restraint System such as "AIR BAG" and "SEAT BELT PRE-TENSIONER", used along with a front seat belt, helps to reduce the risk or severity of injury to the driver and front passenger for certain types of collision. This system includes seat belt switch inputs and dual stage front air bag modules. The SRS system uses the seat belt switches to determine the front air bag deployment, and may only deploy one front air bag, depending on the severity of a collision and whether the front occupants are belted or unbelted. Information necessary to service the system safely is included in the "SRS AIR BAG" and "SEAT BELT" of this Service Manual.

WARNING:

Always observe the following items for preventing accidental activation.

- To avoid rendering the SRS inoperative, which could increase the risk of personal injury or death in the event of a collision that would result in air bag inflation, all maintenance must be performed by an authorized NISSAN/INFINITI dealer.
- Improper maintenance, including incorrect removal and installation of the SRS, can lead to personal injury caused by unintentional activation of the system. For removal of Spiral Cable and Air Bag Module, see "SRS AIR BAG".
- Never use electrical test equipment on any circuit related to the SRS unless instructed to in this Service Manual. SRS wiring harnesses can be identified by yellow and/or orange harnesses or harness connectors.

PRECAUTIONS WHEN USING POWER TOOLS (AIR OR ELECTRIC) AND HAMMERS

WARNING:

Always observe the following items for preventing accidental activation.

- When working near the Air Bag Diagnosis Sensor Unit or other Air Bag System sensors with the ignition ON or engine running, never use air or electric power tools or strike near the sensor(s) with a hammer. Heavy vibration could activate the sensor(s) and deploy the air bag(s), possibly causing serious injury.
- When using air or electric power tools or hammers, always switch the ignition OFF, disconnect the battery, and wait at least 3 minutes before performing any service.

A
B
C
D
E
F
G
H
I
J
K
L

PCS

< SYSTEM DESCRIPTION >

SYSTEM DESCRIPTION

COMPONENT PARTS

IPDM E/R

IPDM E/R : Component Parts Location

INFOID:000000007081902

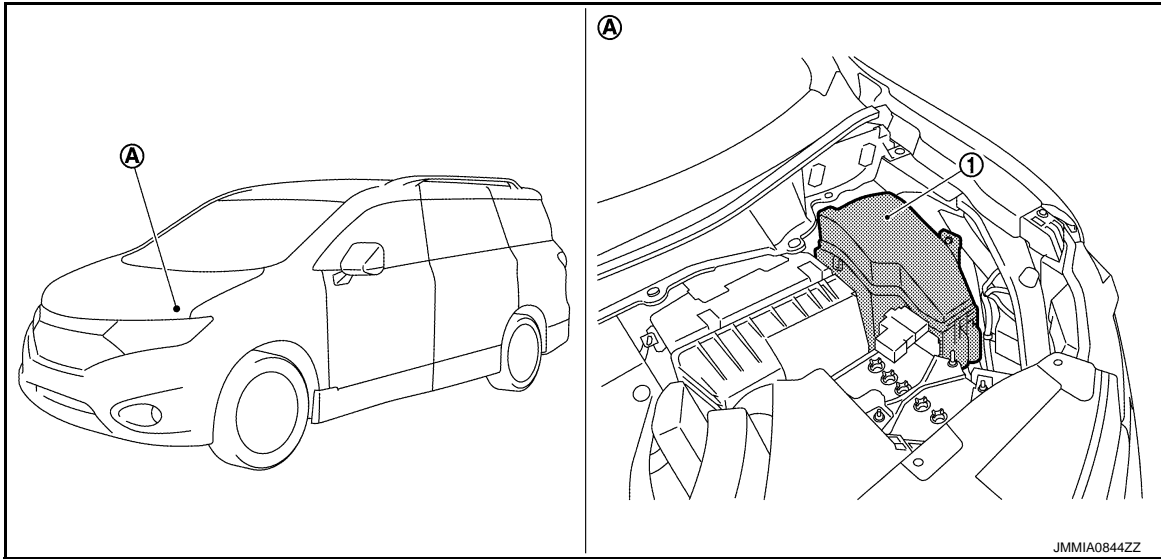

- 1. IPDM E/R
- A. Engine room (LH)

SYSTEM

[IPDM E/R]

< SYSTEM DESCRIPTION >

SYSTEM

RELAY CONTROL SYSTEM

RELAY CONTROL SYSTEM : System Description

INFOID:000000007081904

SYSTEM DIAGRAM

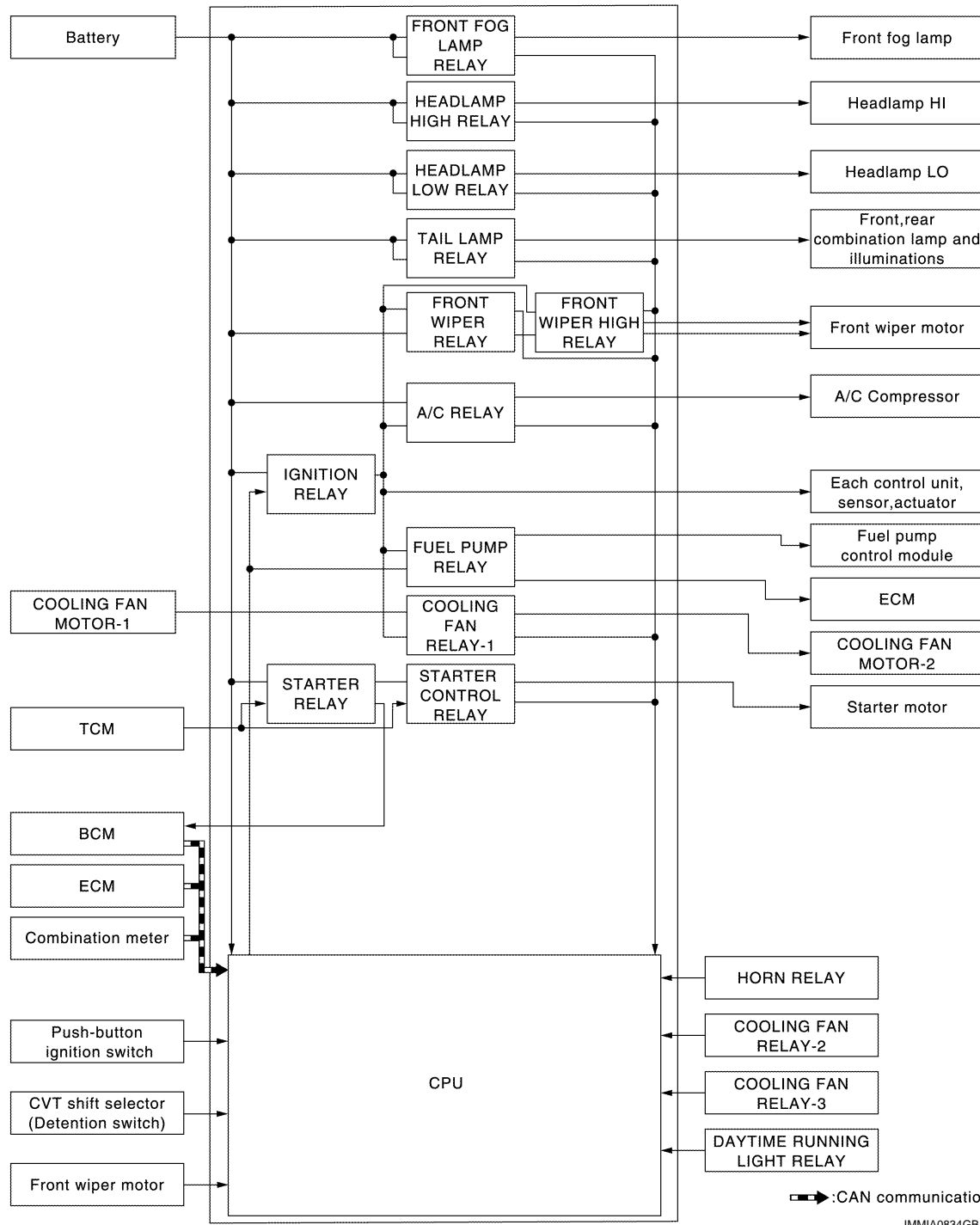

A
B
C
D
E
F
G
H
I
J
K
L
PCS
N
O
P

DESCRIPTION

IPDM E/R activates the internal control circuit to perform the relay ON-OFF control according to the input signals from various sensors and the request signals received from control units via CAN communication.

CAUTION:

To prevent damage to the parts, IPDM E/R integrated relays cannot be removed.

JMMA0834GB

SYSTEM

< SYSTEM DESCRIPTION >

[IPDM E/R]

Control relay	Input/output	Transmit unit	Control part	Reference page
Headlamp low relay	Low beam request signal	BCM (CAN)	Headlamp (LO)	<ul style="list-style-type: none"> • EXL-11 (Xenon type) • EXL-122 (Halogen type)
Headlamp high relay	High beam request signal	BCM (CAN)	Headlamp (HI)	
Front fog lamp relay	Front fog light request signal	BCM (CAN)	Front fog lamp	<ul style="list-style-type: none"> • EXL-25 (Xenon type) • EXL-136 (Halogen type)
Tail lamp relay	Position light request signal	BCM (CAN)	<ul style="list-style-type: none"> • Parking lamp • license plate lamp • Tail lamp • Side marker lamp 	<ul style="list-style-type: none"> • EXL-22 (Xenon type) • EXL-133 (Halogen type)
			Illumination	INL-15
<ul style="list-style-type: none"> • Front wiper relay • Front wiper high relay 	Front wiper request signal	BCM (CAN)	Front wiper motor	WW-7
	Front wiper stop position signal	Front wiper motor		
Horn relay	<ul style="list-style-type: none"> • Theft warning horn request signal • Horn reminder signal 	BCM (CAN)	<ul style="list-style-type: none"> • Horn (high) • Horn (low) 	SEC-19
<ul style="list-style-type: none"> • Starter relay* • Starter control relay 	Starter control relay signal	BCM (CAN)	Starter motor	SEC-5
	Starter relay control signal	TCM		
	Starter motor relay cut off signal	ECM (CAN)		EC-52
A/C relay	A/C compressor request signal	ECM (CAN)	A/C compressor (magnet clutch)	<ul style="list-style-type: none"> • HAC-19 (Automatic air conditioning) • HAC-162 (Manual air conditioning)
<ul style="list-style-type: none"> • Cooling fan relay-1 • Cooling fan relay-2 • Cooling fan relay-3 	Cooling fan speed request signal	ECM (CAN)	<ul style="list-style-type: none"> • Cooling fan motor-1 • Cooling fan motor-2 	EC-41
Ignition relay	Ignition switch ON signal	BCM (CAN)	Each control unit, sensor, actuator and relay (ignition power supply)	PCS-31
	Vehicle speed signal	Combination meter (CAN)		
	Push-button ignition switch signal	Push-button ignition switch		
Daytime running light relay	Daytime running light request signal	BCM (CAN)	Headlamp (HI)	<ul style="list-style-type: none"> • EXL-19 (Xenon type) • EXL-130 (Halogen type)

*: BCM controls the starter relay.

RELAY CONTROL SYSTEM : Fail-safe

INFOID:000000007094693

CAN COMMUNICATION CONTROL

When CAN communication with ECM and BCM is impossible, IPDM E/R performs fail-safe control. After CAN communication recovers normally, it also returns to normal control.

If No CAN Communication Is Available With ECM

SYSTEM

< SYSTEM DESCRIPTION >

[IPDM E/R]

Control part	Fail-safe operation
Cooling fan	<ul style="list-style-type: none"> • Turns ON the cooling fan relay-2 and the cooling fan relay-3 when the ignition switch is turned ON (Cooling fan operates at HI) • Turns OFF the cooling fan relay-1, the cooling fan relay-2 and the cooling fan relay-3 when the ignition switch is turned OFF (Cooling fan does not operate)
A/C compressor	A/C relay OFF
Alternator	Outputs the power generation command signal (PWM signal) 0%

If No CAN Communication Is Available With BCM

Control part	Fail-safe operation
Headlamp	<ul style="list-style-type: none"> • Turns ON the headlamp low relay when the ignition switch is turned ON • Turns OFF the headlamp low relay when the ignition switch is turned OFF • Headlamp high relay OFF
<ul style="list-style-type: none"> • Parking lamp • License plate lamp • Illumination • Tail lamp • Side marker lamp 	<ul style="list-style-type: none"> • Turns ON the tail lamp relay when the ignition switch is turned ON • Turns OFF the tail lamp relay when the ignition switch is turned OFF
Front wiper motor	<ul style="list-style-type: none"> • The status just before activation of fail-safe control is maintained until the ignition switch is turned OFF while the front wiper is operating at LO or HI speed. • The wiper is operated at LO speed until the ignition switch is turned OFF if the fail-safe control is activated while the front wiper is set in the AUTO mode and the front wiper motor is operating. • Returns automatically wiper to stop position when ignition switch is turned ON if fail-safe control is activated while front wiper motor is operated and wiper stop in the other than stop position.
Front fog lamp	Front fog lamp relay OFF
Horn	Horn relay OFF
Ignition relay	The status just before activation of fail-safe is maintained.
Starter motor	Starter control relay OFF

IGNITION RELAY MALFUNCTION DETECTION FUNCTION

- IPDM E/R monitors the voltage at the contact circuit and excitation coil circuit of the ignition relay inside it.
- IPDM E/R judges the ignition relay error if the voltage differs between the contact circuit and the excitation coil circuit.
- If the ignition relay cannot turn OFF due to contact seizure, it activates the tail lamp relay and daytime running light relay for 10 minutes to alert the user to the ignition relay malfunction when the ignition switch is turned OFF.

Voltage judgment		IPDM E/R judgment	Operation
Ignition relay contact side	Ignition relay excitation coil side		
ON	ON	Ignition relay ON normal	—
OFF	OFF	Ignition relay OFF normal	—
ON	OFF	Ignition relay ON stuck	<ul style="list-style-type: none"> • Detects DTC "B2098: IGN RELAY ON" • Turns ON the tail lamp relay for 10 minutes
OFF	ON	Ignition relay OFF stuck	Detects DTC "B2099: IGN RELAY OFF"

FRONT WIPER PROTECTION FUNCTION

IPDM E/R detects front wiper stop position by a front wiper stop position signal. When a front wiper stop position signal is in the conditions listed below, IPDM E/R stops power supply to wiper after repeating a front wiper 10 seconds activation and 20 seconds stop five times.

SYSTEM

< SYSTEM DESCRIPTION >

[IPDM E/R]

Ignition switch	Front wiper switch	Front wiper stop position signal
ON	OFF	The front wiper stop position signal (stop position) cannot be input for 10 seconds.
	ON	The front wiper stop position signal does not change for 10 seconds.

NOTE:

This operation status can be confirmed on the IPDM E/R “Data Monitor” that displays “BLOCK” for the item “WIP PROT” while the wiper is stopped.

STARTER MOTOR PROTECTION FUNCTION

IPDM E/R turns OFF the starter control relay to protect the starter motor when the starter control relay remains active for 90 seconds.

POWER CONTROL SYSTEM

POWER CONTROL SYSTEM : System Description

INFOID:000000007081907

SYSTEM DIAGRAM

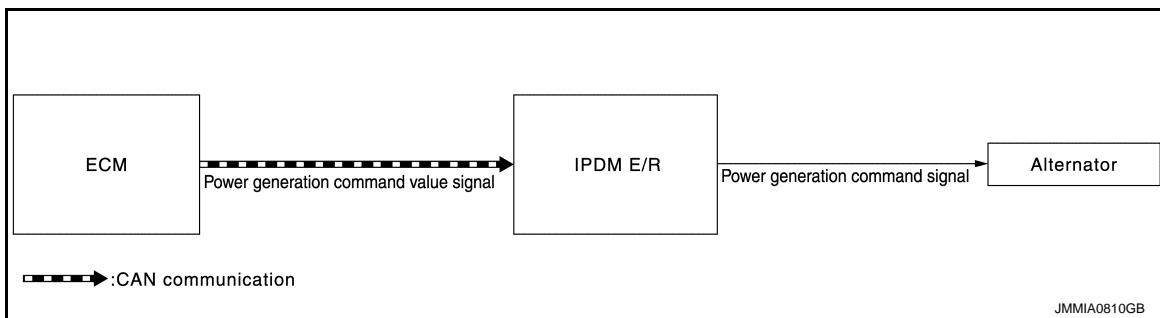

DESCRIPTION

Alternator Control

IPDM E/R outputs power generation command signal (PWM signal) to the alternator according to the status of the power generation command value signal received from ECM via CAN communication. Refer to [CHG-7, "CHARGING SYSTEM : System Description"](#).

SIGNAL BUFFER SYSTEM

SIGNAL BUFFER SYSTEM : System Description

INFOID:000000007081909

SYSTEM DIAGRAM

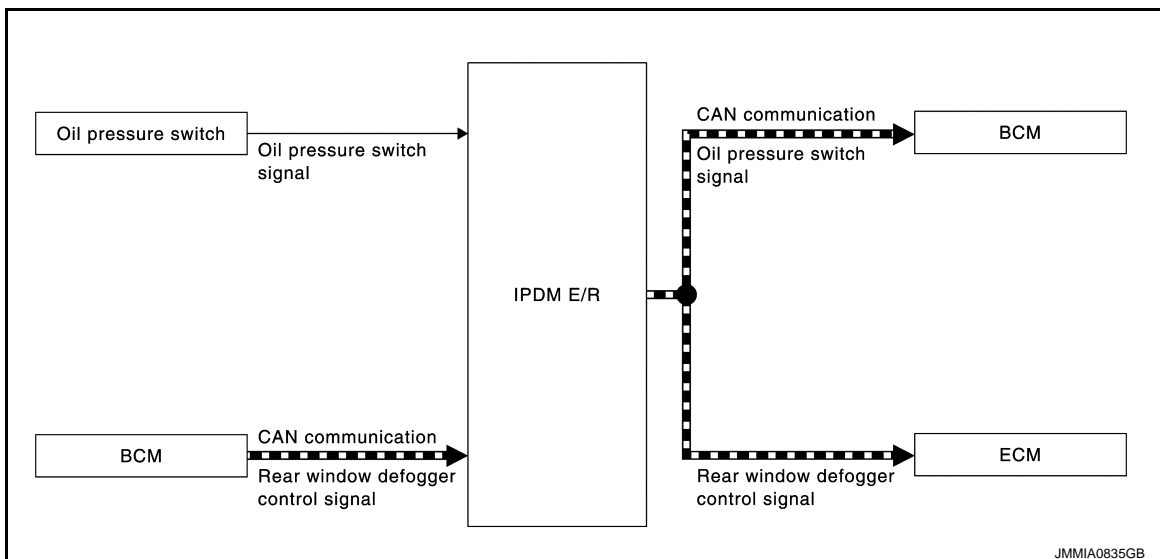

DESCRIPTION

- IPDM E/R reads the status of the oil pressure switch and transmits the oil pressure switch signal to BCM via CAN communication. Refer to [MWI-16, "OIL PRESSURE WARNING LAMP : System Description"](#).

SYSTEM

[IPDM E/R]

< SYSTEM DESCRIPTION >

- IPDM E/R receives the rear window defogger control signal from BCM via CAN communication and transmits it to ECM via CAN communication. Refer to [DEF-5, "System Description"](#).

POWER CONSUMPTION CONTROL SYSTEM

POWER CONSUMPTION CONTROL SYSTEM : System Diagram

INFOID:000000007094913

POWER CONSUMPTION CONTROL SYSTEM : System Description

INFOID:000000007081911

SYSTEM DIAGRAM

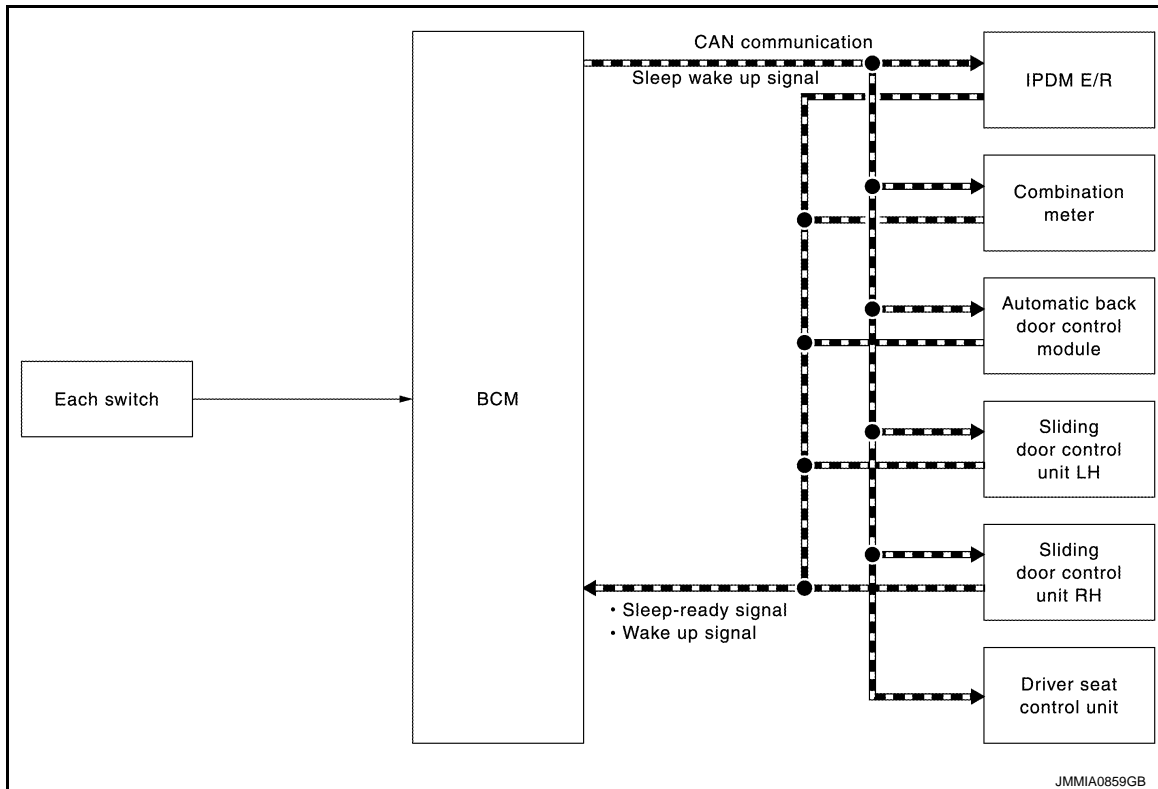

DESCRIPTION

Outline

- IPDM E/R incorporates a power consumption control function that reduces the power consumption according to the vehicle status.
- IPDM E/R changes its status (control mode) with the sleep wake up signal received from BCM via CAN communication.

Normal mode (wake-up)

- CAN communication is normally performed with other control units.
- Individual unit control by IPDM E/R is normally performed.

Low power consumption mode (sleep)

- Low power consumption control is active.
- CAN transmission is stopped.

Sleep Mode Activation

- IPDM E/R judges that the sleep-ready conditions are fulfilled when the ignition switch is OFF and none of the conditions below are present. Then it transmits a sleep-ready signal (ready) to BCM via CAN communication.
 - Outputting signals to actuators
 - Switches or relays operating
 - Output requests are being received from control units via CAN communication.
- IPDM E/R stops CAN communication and enters the low power consumption mode when it receives a sleep wake up signal (sleep) from BCM and the sleep-ready conditions are fulfilled.

Wake-up Operation

A

B

C

D

E

F

G

H

I

J

K

L

PCS

N

O

P

SYSTEM

[IPDM E/R]

< SYSTEM DESCRIPTION >

- IPDM E/R changes from the low power consumption mode to the normal mode when it receives a sleep wake-up signal (wake up) from BCM or any of the following conditions is fulfilled. In addition, it transmits a sleep-ready signal (not-ready) to BCM via CAN communication to report the CAN communication start.
- Ignition switch ON
- An output request is received from a control unit via CAN communication.

DIAGNOSIS SYSTEM (IPDM E/R)

Diagnosis Description

INFOID:000000007081912

AUTO ACTIVE TEST

Description

In auto active test, the IPDM E/R sends a drive signal to the following systems to check their operation.

- Oil pressure warning lamp
- Front wiper (LO, HI)
- Parking lamp
- License plate lamp
- Tail lamp
- Side marker lamp
- Front fog lamp
- Headlamp (LO, HI)
- A/C compressor (magnet clutch)
- Cooling fan

Operation Procedure

NOTE:

Never perform auto active test in the following condition.

- Passenger door is open.
 - CONSULT is connected.
1. Close the hood and lift the wiper arms from the windshield. (Prevent windshield damage due to wiper operation)
NOTE:
 When auto active test is performed with hood opened, sprinkle water on windshield beforehand.
 2. Turn the ignition switch OFF.
 3. Turn the ignition switch ON, and within 20 seconds, press the front door switch (driver side) 10 times. Then turn the ignition switch OFF.
 4. Turn the ignition switch ON within 10 seconds. After that the horn sounds once and the auto active test starts.
NOTE:
 Engine starts when ignition switch is turned ON while brake pedal is depressed.
 5. The oil pressure warning lamp starts blinking when the auto active test starts.
 6. After a series of the following operations is repeated 3 times, auto active test is completed.

NOTE:

- When auto active test has to be cancelled halfway through test, turn the ignition switch OFF.
- When auto active test is not activated, door switch may be the cause. Check door switch. Refer to [DLK-235, "Component Function Check"](#).

Inspection in Auto Active Test

When auto active test is actuated, the following 6 steps are repeated 3 times.

Operation sequence	Inspection location	Operation
1	Oil pressure warning lamp	Blinks continuously during operation of auto active test
2	Front wiper motor	LO for 5 seconds → HI for 5 seconds
3	<ul style="list-style-type: none"> • Parking lamp • License plate lamp • Tail lamp • Side marker lamp • Front fog lamp 	10 seconds
4	Headlamp	<ul style="list-style-type: none"> • LO 10 seconds • HI ON ↔ OFF 5 times
5	A/C compressor (magnet clutch)	ON ↔ OFF 5 times
6	Cooling fan	LO for 5 seconds → MID for 3 seconds → HI for 2 seconds

A

B

C

D

E

F

G

H

I

J

K

L

PCS

N

O

P

DIAGNOSIS SYSTEM (IPDM E/R)

< SYSTEM DESCRIPTION >

[IPDM E/R]

Concept of auto active test

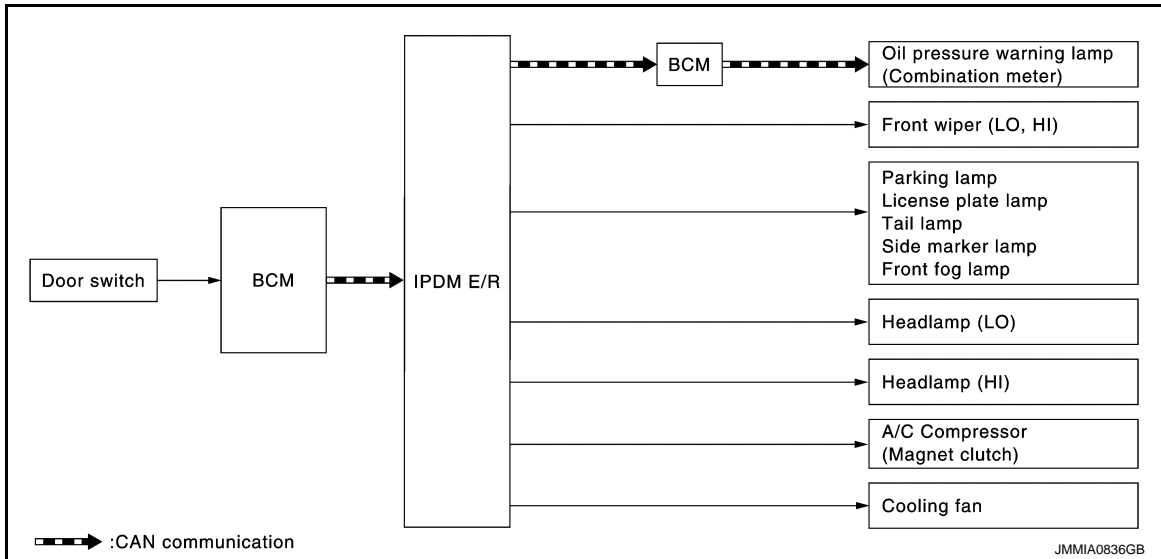

- IPDM E/R starts the auto active test with the door switch signals transmitted by BCM via CAN communication. Therefore, the CAN communication line between IPDM E/R and BCM is considered normal if the auto active test starts successfully.
- The auto active test facilitates troubleshooting if any systems controlled by IPDM E/R cannot be operated.

Diagnosis chart in auto active test

Symptom	Inspection contents	Possible cause
Any of the following components do not operate • Parking lamp • License plate lamp • Tail lamp • Side marker lamp • Front fog lamp • Headlamp (HI, LO) • Front wiper motor	Perform auto active test. Does the applicable system operate?	YES BCM signal input circuit
		NO • Lamp or motor • Lamp or motor ground circuit • Harness or connector between IPDM E/R and applicable system • IPDM E/R
A/C compressor does not operate	Perform auto active test. Does the magnet clutch operate?	YES • Combination meter signal input circuit • CAN communication signal between Combination meter and ECM • CAN communication signal between ECM and IPDM E/R
		NO • Magnet clutch • Harness or connector between IPDM E/R and magnet clutch • IPDM E/R
Oil pressure warning lamp does not operate	Perform auto active test. Does the oil pressure warning lamp blink?	YES • Harness or connector between IPDM E/R and oil pressure switch • Oil pressure switch • IPDM E/R
		NO • CAN communication signal between IPDM E/R and BCM • CAN communication signal between BCM and Combination meter • Combination meter

DIAGNOSIS SYSTEM (IPDM E/R)

< SYSTEM DESCRIPTION >

[IPDM E/R]

Symptom	Inspection contents	Possible cause
Cooling fan does not operate	Perform auto active test. Does the cooling fan operate?	YES <ul style="list-style-type: none"> • ECM signal input circuit • CAN communication signal between ECM and IPDM E/R
		NO <ul style="list-style-type: none"> • Cooling fan • Harness or connector between cooling fan and cooling fan relay • Harness or connector between IPDM E/R and cooling fan relay • Cooling fan relay • IPDM E/R

A
B
C
D

CONSULT Function (IPDM E/R)

INFOID:000000007081913

APPLICATION ITEM

CONSULT performs the following functions via CAN communication with IPDM E/R.

Diagnosis mode	Description
Ecu Identification	Allows confirmation of IPDM E/R part number.
Self Diagnostic Result	Displays the diagnosis results judged by IPDM E/R.
Data Monitor	Displays the real-time input/output data from IPDM E/R input/output data.
Active Test	IPDM E/R can provide a drive signal to electronic components to check their operations.
CAN Diag Support Monitor	The results of transmit/receive diagnosis of CAN communication can be read.

E
F
G
H

SELF DIAGNOSTIC RESULT

Refer to [PCS-24, "DTC Index"](#).

DATA MONITOR

Monitor item

Monitor Item [Unit]	MAIN SIGNALS	Description
MOTOR FAN REQ [1/2/3/4]	×	Displays the value of the cooling fan speed signal received from ECM via CAN communication.
AC COMP REQ [Off/On]	×	Displays the status of the A/C compressor request signal received from ECM via CAN communication.
TAIL&CLR REQ [Off/On]	×	Displays the status of the position light request signal received from BCM via CAN communication.
HL LO REQ [Off/On]	×	Displays the status of the low beam request signal received from BCM via CAN communication.
HL HI REQ [Off/On]	×	Displays the status of the high beam request signal received from BCM via CAN communication.
FR FOG REQ [Off/On]	×	Displays the status of the front fog light request signal received from BCM via CAN communication.
FR WIP REQ [Stop/1LOW/Low/Hi]	×	Displays the status of the front wiper request signal received from BCM via CAN communication.
WIP AUTO STOP [STOP P/ACT P]	×	Displays the status of the front wiper stop position signal judged by IPDM E/R.
WIP PROT [Off/BLOCK]	×	Displays the status of the front wiper fail-safe operation judged by IPDM E/R.
IGN RLY1 -REQ [Off/On]		Displays the status of the ignition switch ON signal received from BCM via CAN communication.
IGN RLY [Off/On]	×	Displays the status of the ignition relay judged by IPDM E/R.
PUSH SW [Off/On]		Displays the status of the push-button ignition switch judged by IPDM E/R.

I
J
K
L

PCS

N
O
P

DIAGNOSIS SYSTEM (IPDM E/R)

< SYSTEM DESCRIPTION >

[IPDM E/R]

Monitor Item [Unit]	MAIN SIG- NALS	Description
INTER/NP SW [Off/On]		Displays the status of the shift position judged by IPDM E/R.
ST RLY CONT [Off/On]		Displays the status of the starter relay status signal received from BCM via CAN communication.
IHBT RLY -REQ [Off/On]		Displays the status of the starter control relay signal received from BCM via CAN communication.
ST/INHI RLY [Off/ ST /INHI/UNKWN]		Displays the status of the starter relay and starter control relay judged by IPDM E/R.
DETENT SW [Off/On]		Displays the status of the CVT shift selector (detention switch) judged by IPDM E/R.
S/L RLY -REQ [Off/On]		NOTE: The item is indicated, but not monitored.
S/L STATE [LOCK/UNLK/UNKWN]		NOTE: The item is indicated, but not monitored.
DTRL REQ [Off/On]		Displays the status of the daytime running light request signal received from BCM via CAN communication. NOTE: This item is monitored only on the vehicle with daytime running light system.
OIL P SW [Open/Close]		Displays the status of the oil pressure switch judged by IPDM E/R.
HOOD SW [Off/On]		NOTE: The item is indicated, but not monitored.
HL WASHER REQ [Off/On]		NOTE: The item is indicated, but not monitored.
THFT HRN REQ [Off/On]		Displays the status of the theft warning horn request signal received from BCM via CAN communication.
HORN CHIRP [Off/On]		Displays the status of the horn reminder signal received from BCM via CAN communication.
CRNRNG LMP REQ [Off/On]		NOTE: The item is indicated, but not monitored.

ACTIVE TEST

Test item

Test item	Operation	Description
CORNERING LAMP	Off	NOTE: The item is indicated, but cannot be tested.
	LH	
	RH	
HORN	On	Operates horn relay for 20 ms.
FRONT WIPER	Off	OFF
	Lo	Operates the front wiper relay.
	Hi	Operates the front wiper relay and front wiper high relay.
MOTOR FAN	1	OFF
	2	Operates the cooling fan relay-1.
	3	Operates the cooling fan relay-2.
	4	Operates the cooling fan relay-2 and cooling fan relay-3.
HEAD LAMP WASHER	On	NOTE: The item is indicated, but cannot be tested.

DIAGNOSIS SYSTEM (IPDM E/R)

< SYSTEM DESCRIPTION >

[IPDM E/R]

Test item	Operation	Description
EXTERNAL LAMPS	Off	OFF
	TAIL	Operates the tail lamp relay and the daytime running light relay.
	Lo	Operates the headlamp low relay.
	Hi	Operates the headlamp low relay and ON/OFF the headlamp high relay at 1 second intervals.
	Fog	Operates the front fog lamp relay.

A
B
C
D
E
F
G
H
I
J
K
L

PCS

N
O
P

ECU DIAGNOSIS INFORMATION

IPDM E/R

Reference Value

INFOID:000000007081914

VALUES ON THE DIAGNOSIS TOOL

Monitor Item	Condition		Value/Status
MOTOR FAN REQ	Engine idle speed	Changes depending on engine coolant temperature, air conditioner operation status, vehicle speed, etc.	1/2/3/4
AC COMP REQ	Engine running	A/C switch OFF	Off
		A/C switch ON (compressor is operating)	On
TAIL&CLR REQ	Lighting switch OFF		Off
	Lighting switch 1ST, 2ND or AUTO (light is illuminated)		On
HL LO REQ	Lighting switch OFF		Off
	Lighting switch 2ND or AUTO (light is illuminated)		On
HL HI REQ	Lighting switch 2ND or AUTO (light is illuminated)	Lighting switch other than HI and PASS	Off
		Lighting switch HI or PASS	On
FR FOG REQ	Lighting switch 2ND or AUTO (light is illuminated)	Front fog lamp switch OFF	Off
		Lighting switch HI or PASS	
		Front fog lamp switch ON	On
FR WIP REQ	Ignition switch ON	Front wiper switch OFF	Stop
		Front wiper switch INT	1LOW
		Front wiper switch LO	Low
		Front wiper switch HI	Hi
WIP AUTO STOP	Ignition switch ON	Front wiper stop position	STOP P
		Any position other than front wiper stop position	ACT P
WIP PROT	Ignition switch ON	Front wiper operates normally	Off
		Front wiper stops at fail-safe operation	BLOCK
IGN RLY1 -REQ	Ignition switch OFF or ACC		Off
	Ignition switch ON		On
IGN RLY	Ignition switch OFF or ACC		Off
	Ignition switch ON		On
PUSH SW	Release the push-button ignition switch		Off
	Press the push-button ignition switch		On
INTER/NP SW	Ignition switch ON	Selector lever in any position other than P or N	Off
		Selector lever in P or N position	On
ST RLY CONT	Ignition switch ON		Off
	At engine cranking		On
IHBT RLY -REQ	Ignition switch ON		Off
	At engine cranking		On

IPDM E/R

< ECU DIAGNOSIS INFORMATION >

[IPDM E/R]

Monitor Item	Condition	Value/Status	
ST/INHI RLY	Ignition switch ON	Off	A
	At engine cranking	INHI → ST	
	The status of starter relay or starter control relay cannot be recognized by the battery voltage malfunction, etc. when the starter relay is ON and the starter control relay is OFF	UNKWN	B
DETENT SW	Ignition switch ON	Off	C
	<ul style="list-style-type: none"> • Press the selector button with selector lever in P position • Selector lever in any position other than P 		
	Release the selector button with selector lever in P position	On	D
S/L RLY -REQ	NOTE: The item is indicated, but not monitored.	Off	
S/L STATE	NOTE: The item is indicated, but not monitored.	UNLK	E
DTRL REQ	Daytime running light system is not operated	Off	
	Daytime running light system is operated	On	F
OIL P SW	Ignition switch OFF or ACC	Open	
	Ignition switch ON (engine running)		G
	Ignition switch ON (engine stopped)	Close	
HOOD SW	NOTE: The item is indicated, but not monitored.	Off	H
HL WASHER REQ	NOTE: The item is indicated, but not monitored.	Off	
THFT HRN REQ	Not operation	Off	I
	<ul style="list-style-type: none"> • Panic alarm is activated • Theft warning alarm is activated 	On	
HORN CHIRP	Not operation	Off	J
	Door locking with Intelligent Key (horn chirp mode)	On	
CRNRNG LMP REQ	NOTE: The item is indicated, but not monitored.	Off	K

L

PCS

N

O

P

TERMINAL LAYOUT

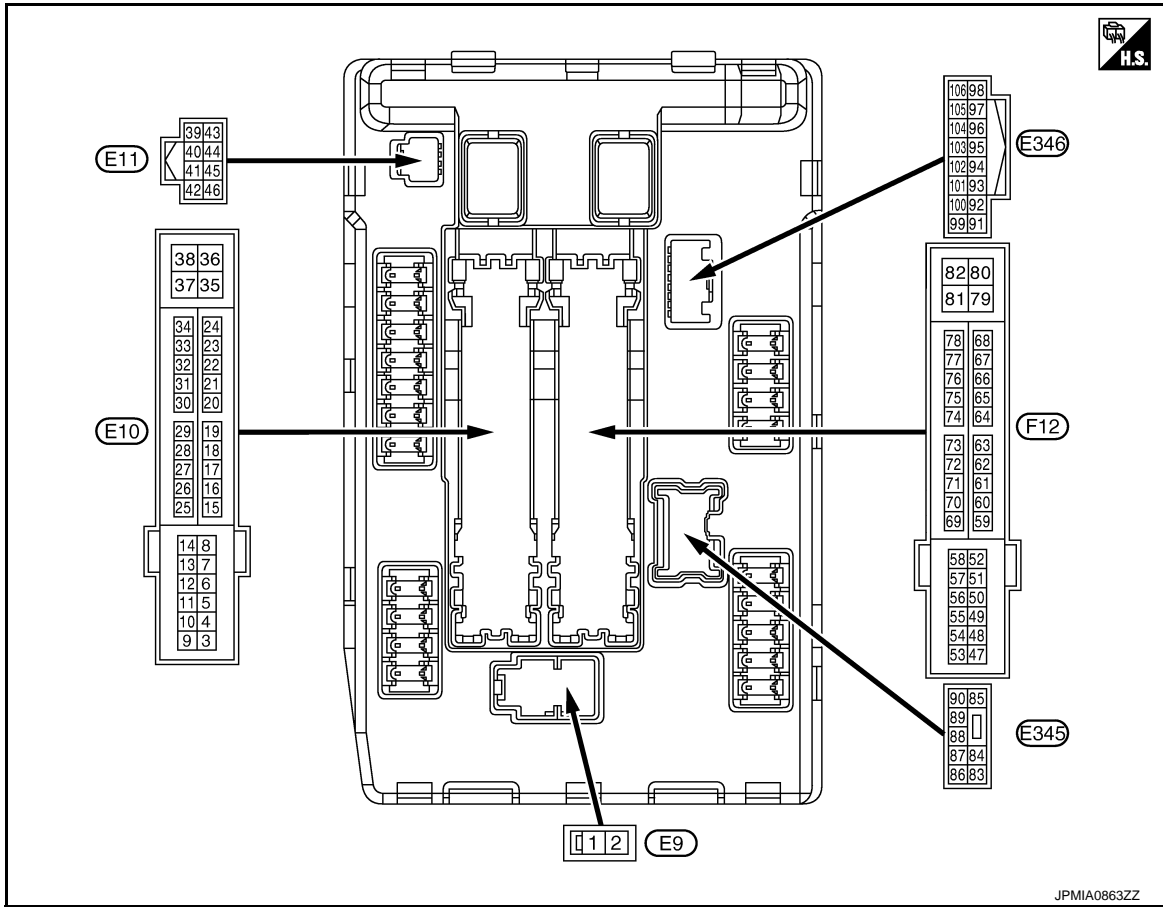

PHYSICAL VALUES

Terminal No. (Wire color)		Description		Condition		Value (Approx.)
+	-	Signal name	Input/ Output			
1 (R)	Ground	Battery power supply	Input	Ignition switch OFF		6 – 16 V
2 (L)	Ground	Battery power supply	Input	Ignition switch OFF		6 – 16 V
4 (LG)	Ground	Front wiper LO	Output	Ignition switch OFF	Front wiper switch OFF	0 – 1 V
				Ignition switch ON	Front wiper switch LO	9 – 16 V
5 (Y)	Ground	Front wiper HI	Output	Ignition switch OFF	Front wiper switch OFF	0 – 1 V
				Ignition switch ON	Front wiper switch HI	9 – 16 V
6 (G)	Ground	Daytime running light relay power supply	Input	Ignition switch OFF		6 – 16 V
7 (BR)	Ground	Illuminations	Output	Lighting switch OFF		0 – 1 V
				Lighting switch 1ST		9 – 16 V
10 (P)	Ground	ECM relay power supply	Output	Ignition switch OFF (More than a few seconds after turning ignition switch OFF)		0 – 1 V
				<ul style="list-style-type: none"> Ignition switch ON Ignition switch OFF (For a few seconds after turning ignition switch OFF) 		6 – 16 V
12 (B)	Ground	Ground	—	Ignition switch ON		0 – 1 V

IPDM E/R

< ECU DIAGNOSIS INFORMATION >

[IPDM E/R]

Terminal No. (Wire color)		Description		Condition	Value (Approx.)	
		Signal name	Input/ Output			
+	-					
13 (G)	Ground	Fuel pump power supply	Output	Approximately 1 second or more after turning the ignition switch ON	0 – 1 V	A
				<ul style="list-style-type: none"> • Approximately 1 second after turning the ignition switch ON • Engine running 	6 – 16 V	B
15 (L)	Ground	Ignition power supply	Output	Ignition switch OFF or ACC	0 – 1 V	C
				Ignition switch ON	6 – 16 V	D
16 (R)	Ground	Front wiper stop position	Input	Ignition switch ON	0 – 1 V	E
				Front wiper stop position	9 – 16 V	F
18 (P)	Ground	Ignition power supply No. 2	Input	Ignition switch OFF or ACC	0 – 1 V	G
				Ignition switch ON	6 – 16 V	H
19 (V)	Ground	Ignition relay power supply	Output	Ignition switch OFF or ACC	0 – 1 V	I
				Ignition switch ON	6 – 16 V	J
20 (W)	Ground	Ambient sensor ground	Output	Ignition switch ON	0 – 1 V	K
21 (O)	Ground	Ambient sensor	Input	Ignition switch ON	0 – 4.8 V NOTE: Changes depending to ambient temperature	L
22 (SB)	Ground	Refrigerant pressure sensor ground	Output	Engine running	<ul style="list-style-type: none"> • Warm-up condition • Idle speed 	M
23 (GR)	Ground	Refrigerant pressure sensor	Output	Engine running	<ul style="list-style-type: none"> • Warm-up condition • Both A/C switch and blower fan motor switch ON (Compressor operates) 	N
24 (G)	Ground	Refrigerant pressure sensor power supply	Input	Ignition switch ON	5 V	O
25 (GR)	Ground	Ignition relay power supply	Output	Ignition switch OFF or ACC	0 – 1 V	P
				Ignition switch ON	6 – 16 V	PCS
27 (BR)	Ground	Ignition relay monitor	Input	Ignition switch OFF or ACC	6 – 16 V	
				Ignition switch ON	0 – 1 V	
28 (G)	Ground	Push-button ignition switch	Input	Press the push-button ignition switch	0 – 1 V	
				Release the push-button ignition switch	6 – 16 V	
30 (LG)	Ground	Starter relay control	Input	Ignition switch ON	Selector lever in any position other than P or N	6 – 16 V
				Selector lever P or N	0 – 1 V	
34 (O)	Ground	Cooling fan relay-3 control	Input	Cooling fan stopped	6 – 16 V	
				Cooling fan at HI operation	0 – 1 V	
35 (P)	Ground	Cooling fan relay-1 power supply	Input	Cooling fan stopped	6 – 16 V	
				Cooling fan at LO operation	4 – 8 V	
36 (G)	Ground	Battery power supply	Input	Ignition switch OFF	6 – 16 V	
38 (GR)	Ground	Cooling fan relay-2 power supply	Output	Cooling fan not operation	0 – 1 V	
				Cooling fan at LO operation	4 – 8 V	
				Cooling fan at HI operation	9 – 16 V	

IPDM E/R

< ECU DIAGNOSIS INFORMATION >

[IPDM E/R]

Terminal No. (Wire color)		Description		Condition	Value (Approx.)	
+	-	Signal name	Input/ Output			
39 (P)	—	CAN-L	Input/ Output	—	—	
40 (L)	—	CAN-H	Input/ Output	—	—	
41 (B)	Ground	Ground	—	Ignition switch ON	0 – 1 V	
42 (SB)	Ground	Cooling fan relay-2 control	Input	Cooling fan stopped	9 – 16 V	
				<ul style="list-style-type: none"> • Cooling fan at MID operation • Cooling fan at HI operation 	0 – 1 V	
43 (LG)	Ground	CVT shift selector (Detention switch)	Input	Ignition switch ON	<ul style="list-style-type: none"> • Press the selector but- ton (selector lever P) • Selector lever in any position other than P 	9 – 16 V
					Release the selector but- ton (selector lever P)	0 – 1 V
44 (W)	Ground	Horn relay control	Input	The horn is deactivated	9 – 16 V	
				The horn is activated	0 – 1 V	
45 (Y)	Ground	Horn switch	Input	The horn is deactivated	9 – 16 V	
				The horn is activated	0 – 1 V	
46 (O)	Ground	Starter relay control	Input	At engine cranking	0 – 1 V	
				Other than at engine cranking	6 – 16 V	
48 (W)	Ground	A/C relay power supply	Output	Engine run- ning	A/C switch OFF A/C switch ON (A/C compressor is oper- ating)	0 – 1 V 9 – 16 V
49 (R/B)	Ground	ECM relay power sup- ply	Output	Ignition switch OFF or ACC	0 – 1 V	
				Ignition switch ON	6 – 16 V	
51 (LG)	Ground	Ignition relay power supply	Output	Ignition switch OFF or ACC	0 – 1 V	
				Ignition switch ON	6 – 16 V	
52 (Y/G)	Ground	Ignition relay power supply	Output	Ignition switch OFF or ACC	0 – 1 V	
				Ignition switch ON	6 – 16 V	
53 (R/W)	Ground	ECM relay power sup- ply	Output	Ignition switch OFF (More than a few seconds after turning igni- tion switch OFF)	0 – 1 V	
				<ul style="list-style-type: none"> • Ignition switch ON • Ignition switch OFF (For a few seconds after turning ignition switch OFF) 	6 – 16 V	
54 (G/W)	Ground	Throttle control motor relay power supply	Output	Ignition switch OFF (More than a few seconds after turning igni- tion switch OFF)	0 – 1 V	
				<ul style="list-style-type: none"> • Ignition switch ON • Ignition switch OFF (For a few seconds after turning ignition switch OFF) 	6 – 16 V	
55 (W/L)	Ground	ECM power supply	Output	Ignition switch OFF	6 – 16 V	
56 (R/Y)	Ground	Ignition relay power supply	Output	Ignition switch OFF or ACC	0 – 1 V	
				Ignition switch ON	6 – 16 V	

IPDM E/R

< ECU DIAGNOSIS INFORMATION >

[IPDM E/R]

Terminal No. (Wire color)		Description		Condition	Value (Approx.)	
		Signal name	Input/ Output			
+	-					
57 (O)	Ground	Ignition relay power supply	Output	Ignition switch OFF or ACC	0 – 1 V	
				Ignition switch ON	6 – 16 V	
58 (Y)	Ground	Ignition relay power supply	Output	Ignition switch OFF or ACC	0 – 1 V	
				Ignition switch ON	6 – 16 V	
69 (W/B)	Ground	ECM relay control	Output	Ignition switch OFF (More than a few seconds after turning ignition switch OFF)	6 – 16 V	
				<ul style="list-style-type: none"> • Ignition switch ON • Ignition switch OFF (For a few seconds after turning ignition switch OFF) 	0 – 1 V	
70 (O)	Ground	Throttle control motor relay control	Output	Ignition switch OFF or ACC	6 – 16 V	
				Ignition switch ON	0 – 1 V	
71 (P)	Ground	Cranking request	Output	Ignition switch OFF	0 – 1 V	
				Ignition switch ON	Selector lever P or N	9 – 16 V
					Selector lever in any position other than P or N	
72 (R/B)	Ground	Starter relay control	Input	Ignition switch ON	6 – 16 V	
				Selector lever P or N	0 – 1 V	
75 (LG)	Ground	Oil pressure switch	Input	Engine stopped	0 – 1 V	
				Engine running	9 – 16 V	
76 (SB)	Ground	Power generation command signal	Output	Ignition switch ON	<p style="text-align: right; margin-right: 50px;">JPMIA0001GB 6.6 V</p>	
				40% is set on "ACTIVE TEST", "ALTERNATOR DUTY" of "ENGINE"	<p style="text-align: right; margin-right: 50px;">JPMIA0002GB 4.0 V</p>	
				80% is set on "ACTIVE TEST", "ALTERNATOR DUTY" of "ENGINE"	<p style="text-align: right; margin-right: 50px;">JPMIA0003GB 1.3 V</p>	

A
B
C
D
E
F
G
H
I
J
K
L
N
O
P

PCS

IPDM E/R

< ECU DIAGNOSIS INFORMATION >

[IPDM E/R]

Terminal No. (Wire color)		Description		Condition		Value (Approx.)
+	-	Signal name	Input/ Output			
77 (B)	Ground	Fuel pump relay control	Output	<ul style="list-style-type: none"> • Approximately 1 second after turning the ignition switch ON • Engine running 		0 – 1 V
				Approximately 1 second or more after turning the ignition switch ON		6 – 16 V
80 (B)	Ground	Starter motor	Output	Other than at engine cranking		0 – 1 V
				At engine cranking		6 – 16 V
83 (R)	Ground	Headlamp LO (RH)	Output	Lighting switch OFF		0 – 1 V
				Lighting switch 2ND or AUTO (light is illuminated)		9 – 16 V
84 (L)	Ground	Headlamp LO (LH)	Output	Lighting switch OFF		0 – 1 V
				Lighting switch 2ND or AUTO (light is illuminated)		9 – 16 V
86 (SB)	Ground	Front fog lamp (RH)	Output	Lighting switch 2ND or AUTO (light is illuminated)	Front fog lamp switch ON	9 – 16 V
					Front fog lamp switch OFF	0 – 1 V
87 (Y)	Ground	Front fog lamp (LH)	Output	Lighting switch 2ND or AUTO (light is illuminated)	Front fog lamp switch ON	9 – 16 V
					Front fog lamp switch OFF	0 – 1 V
88 (BR)	Ground	Ignition relay power supply	Output	Ignition switch OFF or ACC		0 – 1 V
				Ignition switch ON		6 – 16 V
89 (V)	Ground	Headlamp HI (RH)	Output	Lighting switch 2ND or AUTO (light is illuminated)	Lighting switch HI or PASS	9 – 16 V
					Lighting switch other than HI and PASS	0 – 1 V
90 (G)	Ground	Headlamp HI (LH)	Output	Lighting switch 2ND or AUTO (light is illuminated)	Lighting switch HI or PASS	9 – 16 V
					Lighting switch other than HI and PASS	0 – 1 V
91 (LG)	Ground	Front combination lamp RH	Output	Lighting switch OFF		0 – 1 V
				Lighting switch 1ST		9 – 16 V
92 (P)	Ground	Front combination lamp LH	Output	Lighting switch OFF		0 – 1 V
				Lighting switch 1ST		9 – 16 V
93 (W)	Ground	Headlamp aiming motor RH	Output	Lighting switch OFF		0 – 1 V
				Lighting switch 1ST		9 – 16 V
94 (O)	Ground	Headlamp aiming motor LH	Output	Lighting switch OFF		0 – 1 V
				Lighting switch 1ST		9 – 16 V
99 (Y)	Ground	Ambient sensor ground	Output	Ignition switch ON		0 – 1 V
100 (V)	Ground	Ambient sensor	Input	Ignition switch ON		0 – 4.8 V NOTE: Changes depending to ambient temperature
101 (O)	Ground	Refrigerant pressure sensor ground	Output	Engine running	<ul style="list-style-type: none"> • Warm-up condition • Idle speed 	0 – 1 V

Terminal No. (Wire color)		Description		Condition		Value (Approx.)
+	-	Signal name	Input/ Output			
102 (G)	Ground	Refrigerant pressure sensor	Output	Engine running	<ul style="list-style-type: none"> Warm-up condition Both A/C switch and blower fan motor switch ON (Compressor operates) 	1 – 4 V
103 (BR)	Ground	Refrigerant pressure sensor power supply	Input	Ignition switch ON		5 V
105 (R)	Ground	Daytime running light relay control	Output	Daytime running light deactivated		9 – 16 V
				Daytime running light activated		0 – 1 V

Fail-safe

INFOID:000000007081915

CAN COMMUNICATION CONTROL

When CAN communication with ECM and BCM is impossible, IPDM E/R performs fail-safe control. After CAN communication recovers normally, it also returns to normal control.

If No CAN Communication Is Available With ECM

Control part	Fail-safe operation
Cooling fan	<ul style="list-style-type: none"> Turns ON the cooling fan relay-2 and the cooling fan relay-3 when the ignition switch is turned ON (Cooling fan operates at HI) Turns OFF the cooling fan relay-1, the cooling fan relay-2 and the cooling fan relay-3 when the ignition switch is turned OFF (Cooling fan does not operate)
A/C compressor	A/C relay OFF
Alternator	Outputs the power generation command signal (PWM signal) 0%

If No CAN Communication Is Available With BCM

Control part	Fail-safe operation
Headlamp	<ul style="list-style-type: none"> Turns ON the headlamp low relay when the ignition switch is turned ON Turns OFF the headlamp low relay when the ignition switch is turned OFF Headlamp high relay OFF
<ul style="list-style-type: none"> Parking lamp License plate lamp Illumination Tail lamp Side marker lamp 	<ul style="list-style-type: none"> Turns ON the tail lamp relay when the ignition switch is turned ON Turns OFF the tail lamp relay when the ignition switch is turned OFF
Front wiper motor	<ul style="list-style-type: none"> The status just before activation of fail-safe control is maintained until the ignition switch is turned OFF while the front wiper is operating at LO or HI speed. The wiper is operated at LO speed until the ignition switch is turned OFF if the fail-safe control is activated while the front wiper is set in the AUTO mode and the front wiper motor is operating. Returns automatically wiper to stop position when ignition switch is turned ON if fail-safe control is activated while front wiper motor is operated and wiper stop in the other than stop position.
Front fog lamp	Front fog lamp relay OFF
Horn	Horn relay OFF
Ignition relay	The status just before activation of fail-safe is maintained.
Starter motor	Starter control relay OFF

IGNITION RELAY MALFUNCTION DETECTION FUNCTION

- IPDM E/R monitors the voltage at the contact circuit and excitation coil circuit of the ignition relay inside it.
- IPDM E/R judges the ignition relay error if the voltage differs between the contact circuit and the excitation coil circuit.

< ECU DIAGNOSIS INFORMATION >

- If the ignition relay cannot turn OFF due to contact seizure, it activates the tail lamp relay and daytime running light relay for 10 minutes to alert the user to the ignition relay malfunction when the ignition switch is turned OFF.

Voltage judgment		IPDM E/R judgment	Operation
Ignition relay contact side	Ignition relay excitation coil side		
ON	ON	Ignition relay ON normal	—
OFF	OFF	Ignition relay OFF normal	—
ON	OFF	Ignition relay ON stuck	<ul style="list-style-type: none"> • Detects DTC “B2098: IGN RELAY ON” • Turns ON the tail lamp relay for 10 minutes
OFF	ON	Ignition relay OFF stuck	Detects DTC “B2099: IGN RELAY OFF”

FRONT WIPER PROTECTION FUNCTION

IPDM E/R detects front wiper stop position by a front wiper stop position signal. When a front wiper stop position signal is in the conditions listed below, IPDM E/R stops power supply to wiper after repeating a front wiper 10 seconds activation and 20 seconds stop five times.

Ignition switch	Front wiper switch	Front wiper stop position signal
ON	OFF	The front wiper stop position signal (stop position) cannot be input for 10 seconds.
	ON	The front wiper stop position signal does not change for 10 seconds.

NOTE:

This operation status can be confirmed on the IPDM E/R “Data Monitor” that displays “BLOCK” for the item “WIP PROT” while the wiper is stopped.

STARTER MOTOR PROTECTION FUNCTION

IPDM E/R turns OFF the starter control relay to protect the starter motor when the starter control relay remains active for 90 seconds.

DTC Index

INFOID:000000007081916

NOTE:

- The details of time display are as follows.
 - CRNT: A malfunction is detected now.
 - PAST: A malfunction was detected in the past.
- IGN counter is displayed on FFD (Freeze Frame Data).
 - The number is 0 when is detected now.
 - The number increases like 1 → 2 ... 38 → 39 after returning to the normal condition whenever IGN OFF → ON.
 - The number is fixed to 39 until the self-diagnosis results are erased if it is over 39.

×: Applicable

CONSULT display	Fail-safe	Reference
No DTC is detected. further testing may be required.	—	—
U1000: CAN COMM CIRCUIT	×	PCS-30
B2098: IGN RELAY ON	×	PCS-31
B2099: IGN RELAY OFF	—	PCS-32
B209F: STR CUT OFF OPEN	—	SEC-102
B20A0: STR CUT OFF SHORT	—	SEC-104
B210B: START CONT RLY ON	—	SEC-106
B210C: START CONT RLY OFF	—	SEC-108
B210D: STARTER RELAY ON	—	SEC-110
B210E: STARTER RELAY OFF	—	SEC-112

IPDM E/R

< ECU DIAGNOSIS INFORMATION >

[IPDM E/R]

CONSULT display	Fail-safe	Reference
B210F: INTRLCK/PNP SW ON	—	SEC-115
B2110: INTRLCK/PNP SW OFF	—	SEC-117

A
B
C
D
E
F
G
H
I
J
K
L
N
O
P

PCS

WIRING DIAGRAM

IPDM E/R

Wiring Diagram

INFOID:000000007081917

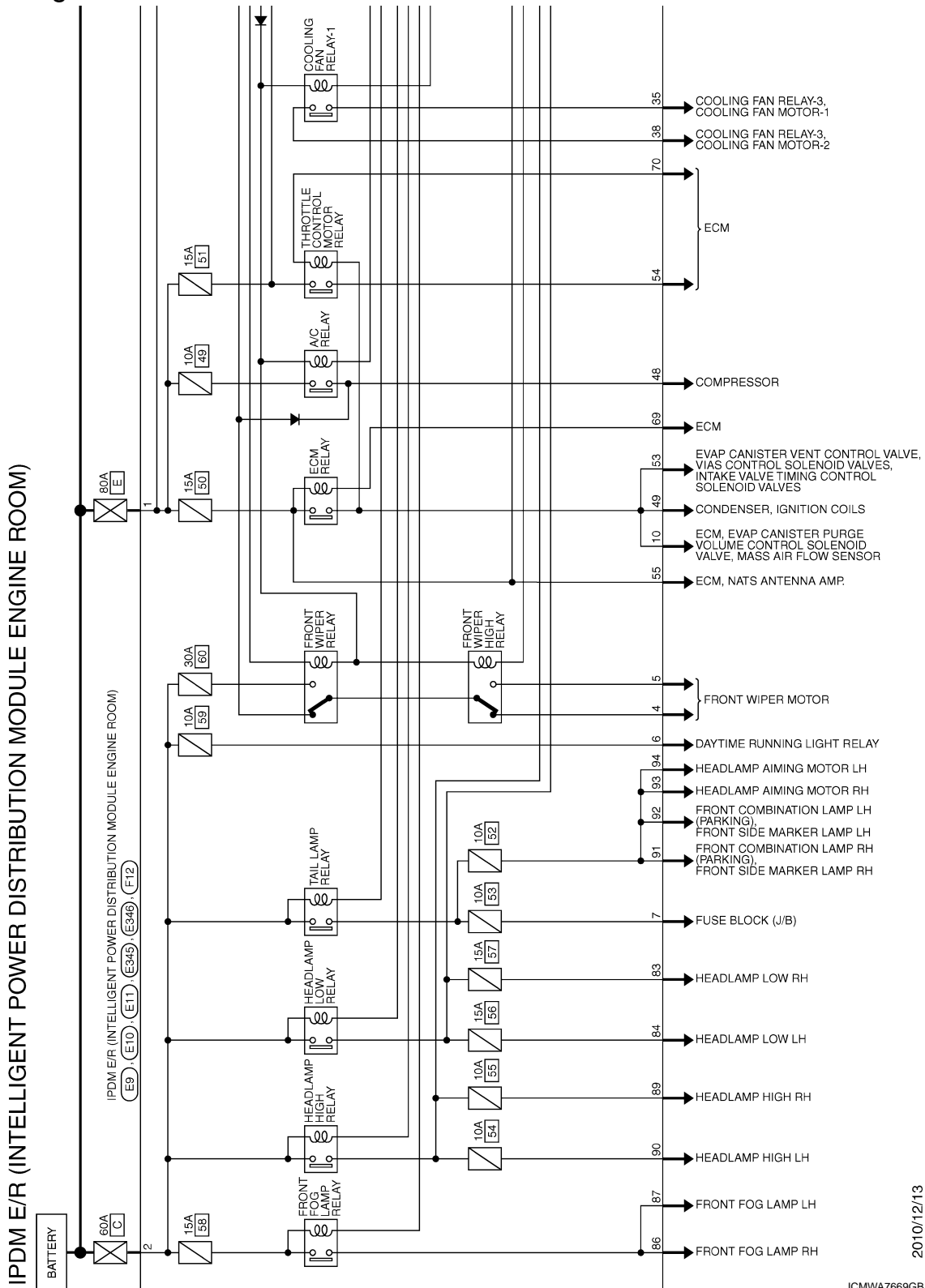

IPDM E/R

< WIRING DIAGRAM >

[IPDM E/R]

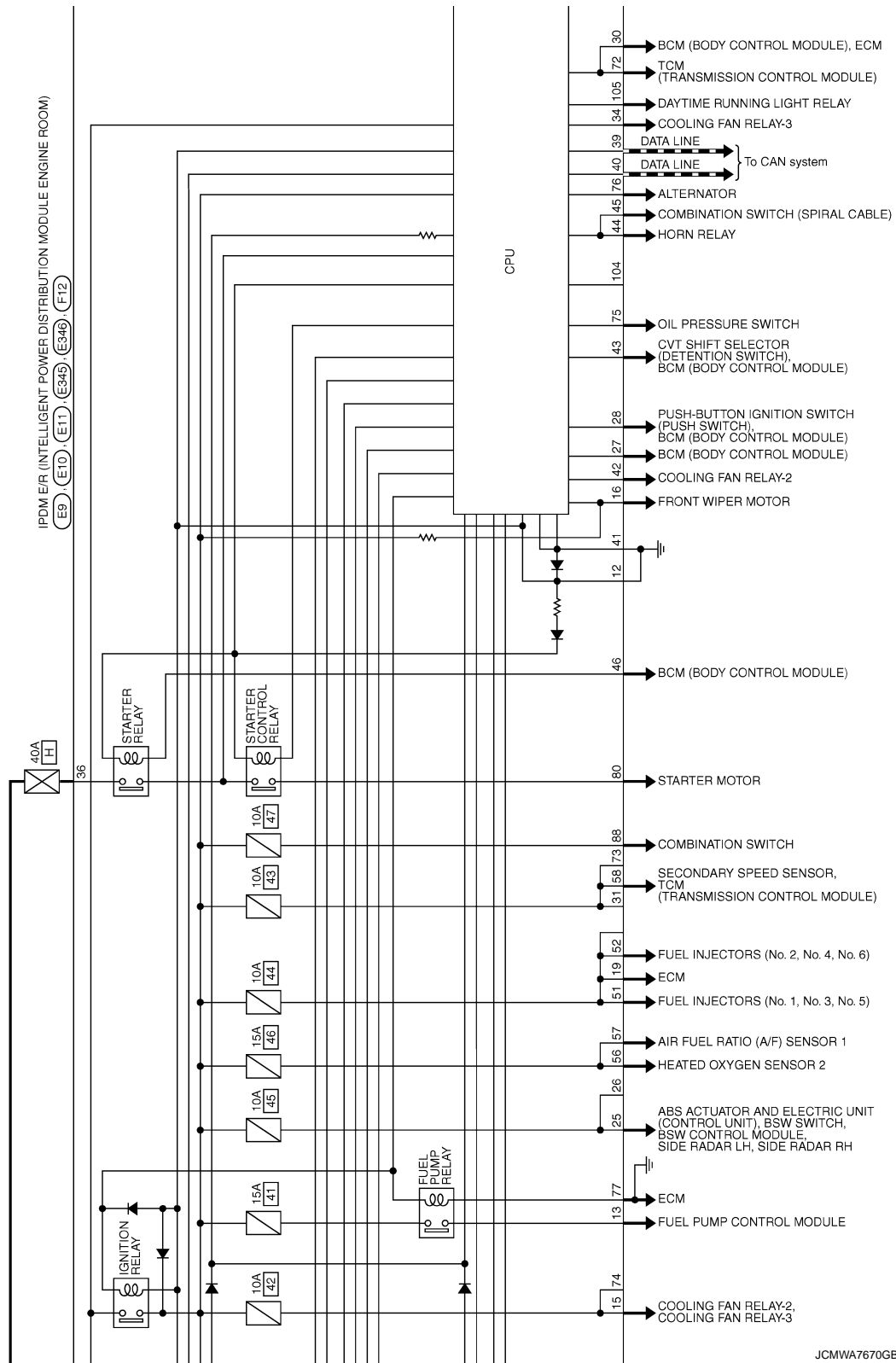

JCMWA7670GB

A
B
C
D
E
F
G
H
I
J
K
L
PCS
N
O
P

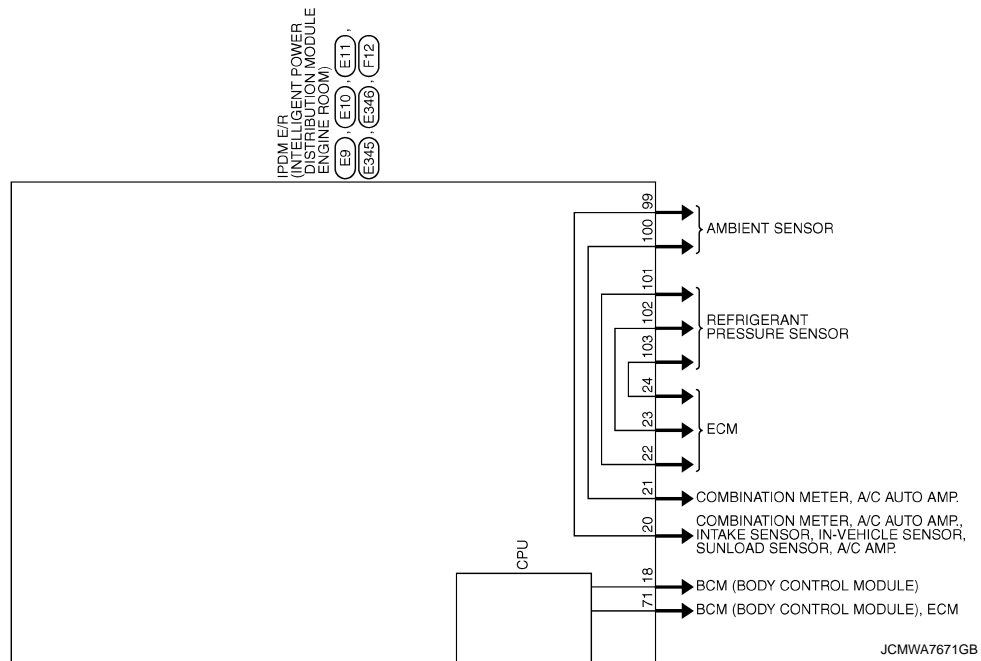

A
B
C
D
E
F
G
H
I
J
K
L
N
O
P

IPDM E/R (INTELLIGENT POWER DISTRIBUTION MODULE ENGINE ROOM)

Connector No.	E9		
Connector Name	IPDM E/R INTELLIGENT POWER DISTRIBUTION MODULE ENGINE ROOM		
Connector Type	LOPE-MC		



1	2
---	---

Terminal No.	Color of Wire	Signal Name [Specification]
1	R	-
2	L	-

Connector No.	E10		
Connector Name	IPDM E/R INTELLIGENT POWER DISTRIBUTION MODULE ENGINE ROOM		
Connector Type	TH20FW-CS12-M4-1V		



9	10	11	12	13	14
3	4	5	6	7	8
15	16	17	18	19	20
21	22	23	24	25	26
27	28	29	30	31	32
33	34	35	36	37	38

Terminal No.	Color of Wire	Signal Name [Specification]
4	LG	-
5	Y	-
6	G	-
7	BR	-
10	P	-
12	B	-
13	G	-
15	L	-
16	R	-
18	P	-
19	V	-
20	W	-
21	O	-
22	SB	-
23	GR	-
24	G	-
25	GR	-
27	BR	-
28	G	-
30	LG	-

Connector No.	E11		
Connector Name	IPDM E/R INTELLIGENT POWER DISTRIBUTION MODULE ENGINE ROOM		
Connector Type	TH08FW-NH		



Terminal No.	Color of Wire	Signal Name [Specification]
34	O	-
35	P	-
36	C	-
38	GR	-

Terminal No.	Color of Wire	Signal Name [Specification]
39	P	-
40	L	-
41	B	-
42	SB	-
43	LG	-
44	W	-
45	Y	-
46	O	-

Connector No.	E345		
Connector Name	IPDM E/R INTELLIGENT POWER DISTRIBUTION MODULE ENGINE ROOM		
Connector Type	NS08FW-CS		



Terminal No.	Color of Wire	Signal Name [Specification]
83	R	-
84	L	-
86	SB	-
87	Y	-
88	BR	-
89	V	-
90	G	-

Connector No.	E346		
Connector Name	IPDM E/R INTELLIGENT POWER DISTRIBUTION MODULE ENGINE ROOM		
Connector Type	TH18FW-NH		



98	97	96	95	84	93	92	91
108	105	104	103	102	101	100	99

Terminal No.	Color of Wire	Signal Name [Specification]
91	LG	-
92	P	-
93	W	-
94	O	-
99	Y	-
100	V	-
101	O	-
102	G	-
103	BR	-
105	R	-

Connector No.	F12		
Connector Name	IPDM E/R INTELLIGENT POWER DISTRIBUTION MODULE ENGINE ROOM		
Connector Type	TH20FW-CS12-M4		



63	64	65	66	67	68	69	70
71	72	73	74	75	76	77	78
79	80	81	82	83	84	85	86

Terminal No.	Color of Wire	Signal Name [Specification]
48	W	-
49	R/B	-
51	LG	-
52	Y/G	-
53	R/W	-
54	G/W	-
55	W/L	-
56	R/Y	-
57	O	-
58	Y	-
68	W/B	-
70	O	-

71	P	-
72	R/B	-
75	LG	-
76	SB	-
77	B	-
80	B	-

JCMWA7672GB



U1000 CAN COMM CIRCUIT

< DTC/CIRCUIT DIAGNOSIS >

[IPDM E/R]

DTC/CIRCUIT DIAGNOSIS

U1000 CAN COMM CIRCUIT

Description

INFOID:000000007081918

CAN (Controller Area Network) is a serial communication line for real time applications. It is an on-vehicle multiplex communication line with high data communication speed and excellent error detection ability. Modern vehicle is equipped with many electronic control unit, and each control unit shares information and links with other control units during operation (not independent). In CAN communication, control units are connected with 2 communication lines (CAN-H line, CAN-L line) allowing a high rate of information transmission with less wiring. Each control unit transmits/receives data but selectively reads required data only.

CAN Communication Signal Chart. Refer to [LAN-32, "CAN COMMUNICATION SYSTEM : CAN Communication Signal Chart"](#).

DTC Logic

INFOID:000000007081919

DTC DETECTION LOGIC

DTC	CONSULT display description	DTC Detection Condition	Possible cause
U1000	CAN COMM CIRCUIT	When IPDM E/R cannot communicate CAN communication signal continuously for 2 seconds or more	CAN communication system

Diagnosis Procedure

INFOID:000000007081920

1.PERFORM SELF DIAGNOSTIC

1. Turn ignition switch ON and wait 2 seconds or more.
2. Check "Self Diagnostic Result" of "IPDM E/R" using CONSULT.

Is DTC "U1000" displayed?

- YES >> Refer to [LAN-17, "Trouble Diagnosis Flow Chart"](#).
NO >> Refer to [GI-42, "Intermittent Incident"](#).

B2098 IGNITION RELAY ON STUCK

[IPDM E/R]

< DTC/CIRCUIT DIAGNOSIS >

B2098 IGNITION RELAY ON STUCK

Description

INFOID:000000007081921

- IPDM E/R operates the ignition relay when it receives an ignition switch ON signal from BCM via CAN communication.
- Turn the ignition relay OFF by pressing the push-button ignition switch once when the vehicle speed is 4 km/h (2.5 MPH) or less.
- Turn the ignition relay OFF with the following operation when the vehicle speed is more than 4 km/h (2.5 MPH) or when an abnormal condition occurs in CAN communication from the unified meter and A/C amp.(Emergency OFF)
 - Press and hold the push-button ignition switch for 2 seconds or more.
 - Press the push-button ignition switch 3 times within 1.5 seconds.

NOTE:

The ignition relay does not turn ON for 3 seconds after emergency OFF even if the push-button ignition switch is pressed.

DTC Logic

INFOID:000000007081922

DTC DETECTION LOGIC

DTC	CONSULT display description	DTC Detection Condition	Possible causes
B2098	IGN RELAY ON	The ignition relay ON is detected for 1 second at ignition switch OFF (CPU monitors the status at the contact and excitation coil circuits of the ignition relay inside it)	Ignition relay malfunction

1.PERFORM DTC CONFIRMATION PROCEDURE

1. Turn ignition switch ON.
2. Check DTC in "Self Diagnostic Result" mode of "IPDM E/R" using CONSULT.

Is DTC detected?

- YES >> Refer to [PCS-31, "Diagnosis Procedure"](#).
- NO >> INSPECTION END.

Diagnosis Procedure

INFOID:000000007081923

1.PERFORM SELF DIAGNOSIS

1. Turn ignition switch OFF, and wait 1 second or more.
2. Turn ignition switch ON.
3. Check "Self Diagnostic Result" of "IPDM E/R" using CONSULT.

Is DTC "B2098" displayed?

- YES >> Replace IPDM E/R. Refer to [PCS-34, "Removal and Installation"](#).
- NO >> Refer to [GI-42, "Intermittent Incident"](#).

A
B
C
D
E
F
G
H
I
J
K
L
N
O
P

PCS

B2099 IGNITION RELAY OFF STUCK

< DTC/CIRCUIT DIAGNOSIS >

[IPDM E/R]

B2099 IGNITION RELAY OFF STUCK

Description

INFOID:000000007081924

- IPDM E/R operates the ignition relay when it receives an ignition switch ON signal from BCM via CAN communication.
- Turn the ignition relay OFF by pressing the push-button ignition switch once when the vehicle speed is 4 km/h (2.5 MPH) or less.
- Turn the ignition relay OFF with the following operation when the vehicle speed is more than 4 km/h (2.5 MPH) or when an abnormal condition occurs in CAN communication from the unified meter and A/C amp.(Emergency OFF)
 - Press and hold the push-button ignition switch for 2 seconds or more.
 - Press the push-button ignition switch 3 times within 1.5 seconds.

NOTE:

The ignition relay does not turn ON for 3 seconds after emergency OFF even if the push-button ignition switch is pressed.

DTC Logic

INFOID:000000007081925

DTC DETECTION LOGIC

DTC	CONSULT display description	DTC Detection Condition	Possible causes
B2099	IGN RELAY OFF	The ignition relay OFF is detected for 1 second at ignition switch ON (CPU monitors the status at the contact and excitation coil circuits of the ignition relay inside it)	Ignition relay malfunction

NOTE:

When IPDM E/R power supply voltage is low (Approx. 7 - 8 V for about 1 second), the "DTC: B2099" may be detected.

1.PERFORM DTC CONFIRMATION PROCEDURE

1. Turn ignition switch ON.
2. Check DTC in "Self Diagnostic Result" mode of "IPDM E/R" using CONSULT.

Is DTC detected?

- YES >> Refer to [PCS-32, "Diagnosis Procedure"](#).
- NO >> INSPECTION END.

Diagnosis Procedure

INFOID:000000007081926

1.PERFORM SELF DIAGNOSIS

1. Turn ignition switch OFF, and wait 1 second or more.
2. Turn ignition switch ON.
3. Check "Self Diagnostic Result" of "IPDM E/R" using CONSULT.

Is "B2099" displayed?

- YES >> Replace IPDM E/R. Refer to [PCS-34, "Removal and Installation"](#).
- NO >> Refer to [GI-42, "Intermittent Incident"](#).

POWER SUPPLY AND GROUND CIRCUIT

< DTC/CIRCUIT DIAGNOSIS >

[IPDM E/R]

POWER SUPPLY AND GROUND CIRCUIT

Diagnosis Procedure

INFOID:000000007081927

1. CHECK FUSES AND FUSIBLE LINK

Check that the following IPDM E/R fuses or fusible links are not blown.

Signal name	Fuses and fusible link No.
Battery power supply	E (80 A)
	C (60 A)
	H (40 A)
	50 (15 A)
	51 (15 A)

Is the fuse fusing?

YES >> Replace the blown fuse or fusible link after repairing the affected circuit if a fuse or fusible link is blown.

NO >> GO TO 2.

2. CHECK POWER SUPPLY CIRCUIT

1. Turn the ignition switch OFF.
2. Disconnect IPDM E/R connector.
3. Check voltage between IPDM E/R harness connector and the ground.

(+)		(-)	Voltage
IPDM E/R			
Connector	Terminal	Ground	6 – 16 V
E9	1		
	2		
E10	36		

Is the measurement value normal?

YES >> GO TO 3.

NO >> Repair the harness or connector.

3. CHECK GROUND CIRCUIT

Check continuity between IPDM E/R harness connectors and the ground.

IPDM E/R		Ground	Continuity
Connector	Terminal		Existed
E10	12		Existed
E11	41		

Does continuity exist?

YES >> INSPECTION END

NO >> Repair the harness or connector.

A
B
C
D
E
F
G
H
I
J
K
L
N
O
P

PCS

REMOVAL AND INSTALLATION

IPDM E/R

Exploded View

INFOID:000000007094026

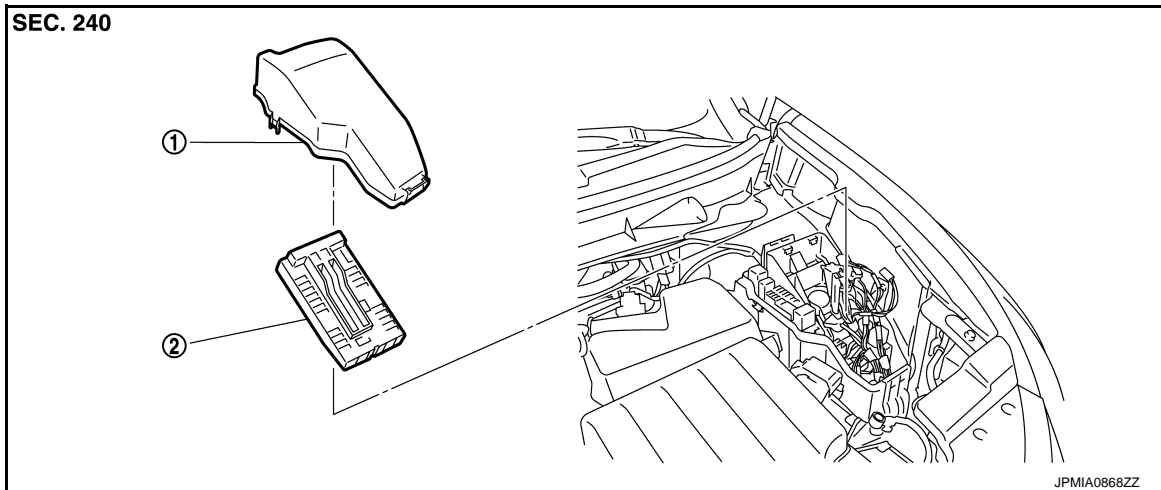

1. Relay box cover

2. IPDM E/R

Removal and Installation

INFOID:000000007094027

CAUTION:

IPDM E/R integrated relays are not serviceable parts, and must not be removed from the unit.

REMOVAL

1. Disconnect the battery cable from the negative terminal.
2. Remove the relay box cover.
3. Disconnect the harness connector from the IPDM E/R (1).
4. Press the pawl (A) and remove the IPDM E/R from relay box.

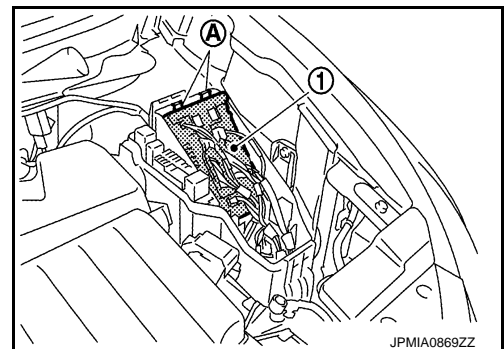

INSTALLATION

Install in the reverse order of removal.

PRECAUTION

PRECAUTIONS

Precaution for Supplemental Restraint System (SRS) "AIR BAG" and "SEAT BELT PRE-TENSIONER"

INFOID:000000007050642

The Supplemental Restraint System such as "AIR BAG" and "SEAT BELT PRE-TENSIONER", used along with a front seat belt, helps to reduce the risk or severity of injury to the driver and front passenger for certain types of collision. This system includes seat belt switch inputs and dual stage front air bag modules. The SRS system uses the seat belt switches to determine the front air bag deployment, and may only deploy one front air bag, depending on the severity of a collision and whether the front occupants are belted or unbelted. Information necessary to service the system safely is included in the "SRS AIR BAG" and "SEAT BELT" of this Service Manual.

WARNING:

Always observe the following items for preventing accidental activation.

- To avoid rendering the SRS inoperative, which could increase the risk of personal injury or death in the event of a collision that would result in air bag inflation, all maintenance must be performed by an authorized NISSAN/INFINITI dealer.
- Improper maintenance, including incorrect removal and installation of the SRS, can lead to personal injury caused by unintentional activation of the system. For removal of Spiral Cable and Air Bag Module, see "SRS AIR BAG".
- Never use electrical test equipment on any circuit related to the SRS unless instructed to in this Service Manual. SRS wiring harnesses can be identified by yellow and/or orange harnesses or harness connectors.

PRECAUTIONS WHEN USING POWER TOOLS (AIR OR ELECTRIC) AND HAMMERS

WARNING:

Always observe the following items for preventing accidental activation.

- When working near the Air Bag Diagnosis Sensor Unit or other Air Bag System sensors with the ignition ON or engine running, never use air or electric power tools or strike near the sensor(s) with a hammer. Heavy vibration could activate the sensor(s) and deploy the air bag(s), possibly causing serious injury.
- When using air or electric power tools or hammers, always switch the ignition OFF, disconnect the battery, and wait at least 3 minutes before performing any service.

A
B
C
D
E
F
G
H
I
J
K
L

PCS

N
O
P

COMPONENT PARTS

< SYSTEM DESCRIPTION >

[POWER DISTRIBUTION SYSTEM]

SYSTEM DESCRIPTION

COMPONENT PARTS

Component Parts Location

INFOID:000000007161358

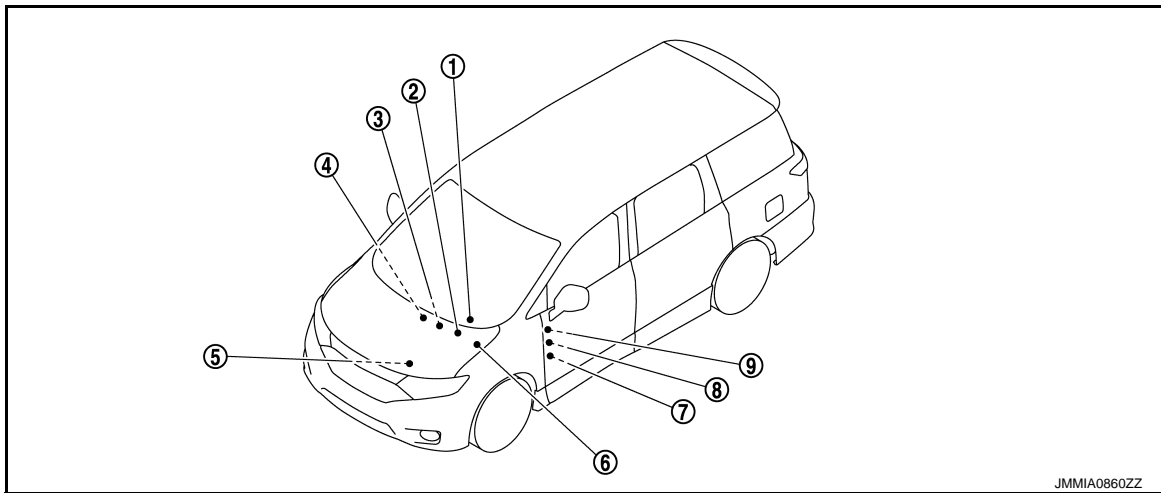

JMMIA0860ZZ

No.	Component	Description
1.	BCM	<ul style="list-style-type: none"> • BCM controls power distribution system. • BCM judges ignition switch position by push-button ignition switch (push switch) and vehicle condition. • BCM checks the ignition switch position internally. Refer to BCS-4, "BODY CONTROL SYSTEM : Component Parts Location" for detailed installation location.
2.	Stop lamp relay	Stop lamp switch detects that brake pedal is depressed, and stop lamp relay transmits the signal to BCM. Refer to BRC-8, "Component Parts Location" for detailed installation location.
3.	Push-button ignition switch	Push-button ignition switch (push switch) is pressed, and transmits the status signal to BCM and IPDM E/R.
4.	CVT shift selector (detention switch)	CVT shift selector (detention switch) detects shift lever status, transmits detention switch signal to BCM. Refer to TM-16, "SHIFT LOCK SYSTEM : Component Parts Location" for detailed installation location.
5.	Transmission range switch	Transmission range switch detects shift position P or N, transmits P/N position signal to BCM. Refer to TM-10, "CVT CONTROL SYSTEM : Component Parts Location" for detailed installation location.
6.	IPDM E/R	<ul style="list-style-type: none"> • IPDM E/R detects push-button ignition switch (push switch) status, and transmits push-button ignition switch status signal (CAN) to BCM. • IPDM E/R receives ignition relay (IPDM E/R) control signal and ignition switch ON signal (CAN) from BCM, and controls ignition relay (built in IPDM E/R) Refer to PCS-4, "IPDM E/R : Component Parts Location" for detailed installation location.
7.	Blower relay (built in fuse block)	<ul style="list-style-type: none"> • Blower relay is controlled by BCM. • Blower relay supplies the ignition switch ON power supply or the ignition switch ON signal to air conditioning system when ignition switch is turned ON. • BCM compares status of blower relay control signal and ignition switch position judged by BCM.
8.	Accessory relay (built in fuse block)	<ul style="list-style-type: none"> • Accessory relay is controlled by BCM. • Accessory relay supplies the accessory power supply or the ignition switch ACC signal to each ECU when ignition switch is turned ACC or ON. • BCM compares status of accessory relay control signal, and ignition switch position judged by BCM.
9.	Ignition relay (built in fuse block)	<ul style="list-style-type: none"> • Ignition relay is controlled by BCM. • Ignition relay supplies the ignition switch ON power supply or the ignition switch ON signal to each ECU and system when ignition switch is turned ON. • BCM compares status of ignition relay control signal and ignition switch position judged by BCM. • BCM monitors the ignition relay operating status by the ignition relay feedback signal.

SYSTEM

POWER DISTRIBUTION SYSTEM

POWER DISTRIBUTION SYSTEM : System Description

INFOID:000000007161359

SYSTEM DIADRAM

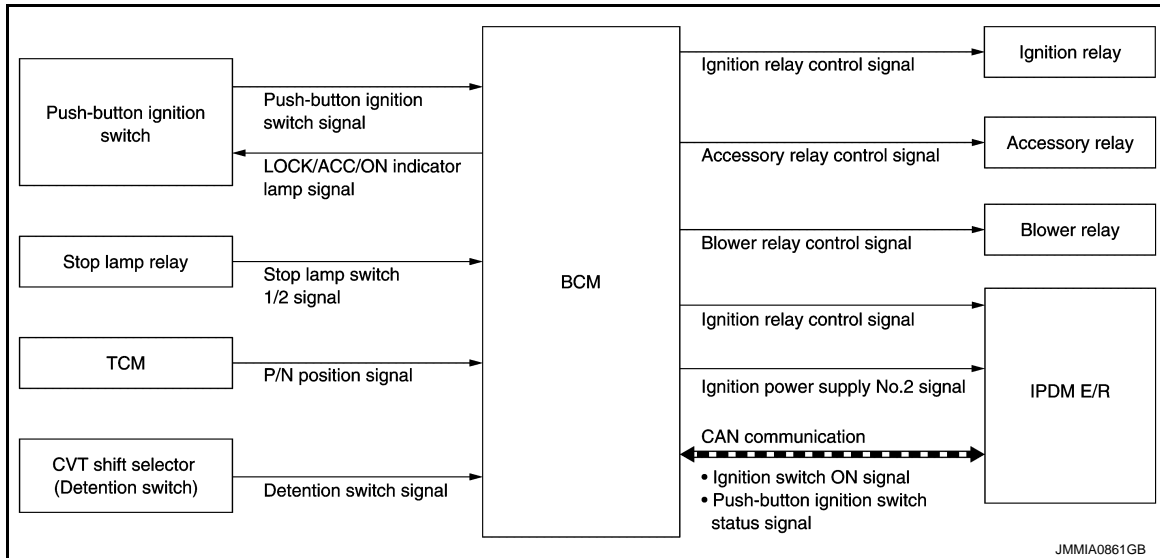

SYSTEM DESCRIPTION

- PDS (POWER DISTRIBUTION SYSTEM) is the system that BCM controls with the operation of the push-button ignition switch and performs the power distribution to each power circuit. This system is used instead of the mechanical power supply changing mechanism with the operation of the conventional key cylinder.
- The push-button ignition switch can be operated when Intelligent Key is in the following condition.
 - Intelligent Key is in the detection area of the inside key antenna.
 - Intelligent Key backside is contacted to push-button ignition switch.
- The push-button ignition switch operation is input to BCM as a signal. BCM changes the ignition switch position according to the status and operates the following relays to supply power to each power circuit.
 - Ignition relay (IPDM E/R)
 - Ignition relay [fuse block (J/B)]
 - Accessory relay
 - Blower relay
- The ignition switch position can be confirmed with the lighting of the LOCK/ACC/ON indicator lamp in the push-button ignition switch.

BATTERY SAVER SYSTEM

When all the following conditions are met for 60 minutes, the battery saver system will cut off the power supply (ignition switch position ACC → OFF) to prevent battery discharge.

- The ignition switch is in the ACC position
- All doors are closed
- Selector lever is in the P position

Reset Condition of Battery Saver System

If any of the following conditions are met the battery saver system is released.

- Opening any door
- Operating with door request switch on door lock
- Operating with Intelligent Key on door lock
- Change ignition switch position to ACC position from OFF position by pressing push-button ignition switch.

IGNITION SWITCH POSITION CHANGE TABLE BY PUSH-BUTTON IGNITION SWITCH OPERATION

Refer to [SEC-8, "INTELLIGENT KEY SYSTEM/ENGINE START FUNCTION : System Description"](#).

A
B
C
D
E
F
G
H
I
J
K
L

PCS

N
O
P

SYSTEM

< SYSTEM DESCRIPTION >

[POWER DISTRIBUTION SYSTEM]

Fail-safe

INFOID:000000007203415

FAIL-SAFE CONTROL BY DTC

BCM performs fail-safe control when any DTC are detected.

Display contents of CONSULT	Fail-safe	Cancellation
B2192: ID DISCORD BCM-ECM	Inhibit engine cranking	Erase DTC
B2193: CHAIN OF BCM-ECM	Inhibit engine cranking	Erase DTC
B2195: ANTI-SCANNING	Inhibit engine cranking	Ignition switch ON → OFF
B2196: DONGLE NG	Inhibit engine cranking	Erase DTC
B2198: NATS ANTENNA AMP	Inhibit engine cranking	Erase DTC
B2608: STARTER RELAY	Inhibit engine cranking	500 ms after the following signal communication status becomes consistent <ul style="list-style-type: none">• Starter motor relay control signal• Starter relay status signal (CAN)
B260F: ENG STATE SIG LOST	Inhibit engine cranking	When any of the following conditions are fulfilled <ul style="list-style-type: none">• Ignition switch changes to ACC• Receives engine status signal (CAN)
B26F1: IGN RELAY OFF	Inhibit engine cranking	When the following conditions are fulfilled <ul style="list-style-type: none">• Ignition switch ON signal (CAN: Transmitted from BCM): ON• Ignition switch ON signal (CAN: Transmitted from IPDM E/R): ON
B26F2: IGN RELAY ON	Inhibit engine cranking	When the following conditions are fulfilled <ul style="list-style-type: none">• Ignition switch ON signal (CAN: Transmitted from BCM): OFF• Ignition switch ON signal (CAN: Transmitted from IPDM E/R): OFF
B26F3: START CONT RLY ON	Inhibit engine cranking	When the following conditions are fulfilled <ul style="list-style-type: none">• Starter control relay signal (CAN: Transmitted from BCM): OFF• Starter control relay signal (CAN: Transmitted from IPDM E/R): OFF
B26F4: START CONT RLY OFF	Inhibit engine cranking	When the following conditions are fulfilled <ul style="list-style-type: none">• Starter control relay signal (CAN: Transmitted from BCM): ON• Starter control relay signal (CAN: Transmitted from IPDM E/R): ON
B26F7: BCM	Inhibit engine cranking by Intelligent Key system	When room antenna and luggage room antenna functions normally

REAR WIPER MOTOR PROTECTION

BCM detects the rear wiper stopping position according to the rear wiper stop position signal.

When the rear wiper stop position signal does not change for more than 5 seconds while driving the rear wiper, BCM stops power supply to protect the rear wiper motor.

Condition of cancellation

1. More than 1 minute is passed after the rear wiper stop.
2. Turn rear wiper switch OFF.
3. Operate the rear wiper switch or rear washer switch.

FAIL-SAFE CONTROL OF COMBINATION SWITCH READING FUNCTION CAUSED BY LOW POWER SUPPLY VOLTAGE

If voltage of battery power supply lower, BCM maintains combination switch reading to the status when input voltage is less than approximately 9 V.

NOTE:

When voltage of battery power supply is approximately 9 V or more, combination switch reading function returns to normal operation.

DIAGNOSIS SYSTEM (BCM)

[POWER DISTRIBUTION SYSTEM]

< SYSTEM DESCRIPTION >

DIAGNOSIS SYSTEM (BCM)

COMMON ITEM

COMMON ITEM : CONSULT Function (BCM - COMMON ITEM)

INFOID:000000007203414

APPLICATION ITEM

CONSULT performs the following functions via CAN communication with BCM.

Diagnosis mode	Function Description
Work Support	Changes the setting for each system function.
Self Diagnostic Result	Displays the diagnosis results judged by BCM.
CAN Diag Support Monitor	Monitors the reception status of CAN communication viewed from BCM.
Data Monitor	The BCM input/output signals are displayed.
Active Test	The signals used to activate each device are forcibly supplied from BCM.
Ecu Identification	The BCM part number is displayed.
Configuration	<ul style="list-style-type: none"> Read and save the vehicle specification. Write the vehicle specification when replacing BCM.

SYSTEM APPLICATION

BCM can perform the following functions for each system.

NOTE:

It can perform the diagnosis modes except the following for all sub system selection items.

x: Applicable item

System	Sub system selection item	Diagnosis mode		
		Work Support	Data Monitor	Active Test
Door lock	DOOR LOCK	x	x	x
Rear window defogger	REAR DEFOGGER		x	x
Warning chime	BUZZER		x	x
Interior room lamp control system	INT LAMP	x	x	x
Exterior lamp	HEAD LAMP	x	x	x
Wiper and washer	WIPER	x	x	x
Turn signal and hazard warning lamps	FLASHER	x	x	x
Air conditioning control system	AIR CONDITONER		x	x*
<ul style="list-style-type: none"> Intelligent Key system Engine start system 	INTELLIGENT KEY	x	x	x
Combination switch	COMB SW		x	
Body control system	BCM	x		
NVIS	IMMU	x	x	x
Interior room lamp battery saver	BATTERY SAVER	x	x	x
Back door open	TRUNK		x	
Vehicle security system	THEFT ALM	x	x	x
RAP system	RETAINED PWR		x	
Signal buffer system	SIGNAL BUFFER		x	x
TPMS	AIR PRESSURE MONITOR	x	x	x

NOTE:

*: For models with automatic air conditioning control system, this diagnosis mode is not used.

FREEZE FRAME DATA (FFD)

The BCM records the following vehicle condition at the time a particular DTC is detected, and displays on CONSULT.

DIAGNOSIS SYSTEM (BCM)

< SYSTEM DESCRIPTION >

[POWER DISTRIBUTION SYSTEM]

CONSULT screen item	Indication/Unit	Description	
Vehicle Speed	km/h	Vehicle speed of the moment a particular DTC is detected	
Odo/Trip Meter	km	Total mileage (Odometer value) of the moment a particular DTC is detected	
Vehicle Condition	SLEEP>LOCK	Power position status of the moment a particular DTC is detected*	While turning BCM status from low power consumption mode to normal mode [Power supply position is OFF (LOCK)]
	SLEEP>OFF		While turning BCM status from low power consumption mode to normal mode [Power supply position is OFF (OFF)]
	LOCK>ACC		While turning power supply position from OFF (LOCK) to ACC
	ACC>ON		While turning power supply position from ACC to ON
	RUN>ACC		While turning power supply position from RUN to ACC (Except emergency stop operation)
	CRANK>RUN		While turning power supply position from CRANK to RUN
	RUN>URGENT		While turning power supply position from RUN to ACC (Emergency stop operation)
	ACC>OFF		While turning power supply position from ACC to OFF (OFF)
	OFF>LOCK		While turning power supply position from OFF (OFF) to OFF (LOCK)
	OFF>ACC		While turning power supply position from OFF (OFF) to ACC
	ON>CRANK		While turning power supply position from ON to CRANK
	OFF>SLEEP		While turning BCM status from normal mode [Power supply position is OFF (OFF)] to low power consumption mode
	LOCK>SLEEP		While turning BCM status from normal mode [Power supply position is OFF (LOCK)] to low power consumption mode
	LOCK		Power supply position is OFF (LOCK)
	OFF		Power supply position is OFF (OFF)
	ACC		Power supply position is ACC
	ON		Power supply position is ON
ENGINE RUN	Power supply position is RUN		
CRANKING	Power supply position is CRANK		
IGN Counter	0 - 39	<p>The number of times that ignition switch is turned ON after DTC is detected</p> <ul style="list-style-type: none"> • The number is 0 when a malfunction is detected now. • The number increases like 1 → 2 → 3...38 → 39 after returning to the normal condition whenever ignition switch OFF → ON. • The number is fixed to 39 until the self-diagnosis results are erased if it is over 39. 	

NOTE:

*: Refer to the following for details of the power supply position.

- OFF (OFF, LOCK): Ignition switch OFF
- ACC: Ignition switch ACC
- IGN: Ignition switch ON with engine stopped
- RUN: Ignition switch ON with engine running
- CRANK: At engine cranking

Power supply position shifts to "OFF (LOCK)" from "OFF (OFF)", when ignition switch is in the OFF position, shift position is in the P position, and any of the following conditions are met.

- Closing door
- Opening door
- Door is locked using door request switch
- Door is locked using Intelligent Key

The power supply position shifts to "ACC" when the push-button ignition switch (push switch) is pushed at "OFF (LOCK)".

INTELLIGENT KEY

DIAGNOSIS SYSTEM (BCM)

[POWER DISTRIBUTION SYSTEM]

< SYSTEM DESCRIPTION >

INTELLIGENT KEY : CONSULT Function (BCM - INTELLIGENT KEY)

INFOID:000000007203417

WORK SUPPORT

Monitor item	Description
INSIDE ANT DIAGNOSIS	This function allows inside key antenna self-diagnosis
LOCK/UNLOCK BY I-KEY	Door lock/unlock function by door request switch mode can be changed to operation in this mode <ul style="list-style-type: none"> • On: Operate • Off: Non-operation
ENGINE START BY I-KEY	Engine start function mode can be changed to operation with this mode <ul style="list-style-type: none"> • On: Operate • Off: Non-operation
TRUNK/GLASS HATCH OPEN	NOTE: This item is displayed, but cannot be used
PANIC ALARM SET	Panic alarm button pressing time on Intelligent Key button can be selected from the following with this mode <ul style="list-style-type: none"> • MODE 1: 0.5 sec • MODE 2: Non-operation • MODE 3: 1.5 sec
TRUNK OPEN DELAY	NOTE: This item is displayed, but cannot be used
LO- BATT OF KEY FOB WARN	Intelligent Key low battery warning mode can be changed to operation with this mode <ul style="list-style-type: none"> • On: Operate • Off: Non-operation
ANTI KEY LOCK IN FUNCTI	Key reminder function mode can be changed to operation with this mode <ul style="list-style-type: none"> • On: Operate • Off: Non-operation
HAZARD ANSWER BACK	Hazard reminder function mode by door request switch and Intelligent Key button can be selected from the following with this mode <ul style="list-style-type: none"> • Lock Only: Door lock operation only • Unlock Only: Door unlock operation only • Lock/Unlock: Lock and unlock operation • Off: Non-operation
ANS BACK I-KEY LOCK	Buzzer reminder function (lock operation) mode by door request switch can be selected from the following with this mode <ul style="list-style-type: none"> • Horn Chirp: Sound horn • Buzzer: Sound Intelligent Key warning buzzer • Off: Non-operation
ANS BACK I-KEY UNLOCK	Buzzer reminder function (unlock operation) mode by door request switch can be changed to operation with this mode <ul style="list-style-type: none"> • On: Operate • Off: Non-operation
SHORT CRANKING OUTPUT	Starter motor can operate during the times below <ul style="list-style-type: none"> • 70 msec • 100 msec • 200 msec
CONFIRM KEY FOB ID	It can be checked whether Intelligent Key ID code is registered or not in this mode
AUTO LOCK SET	Auto door lock operation time can be changed in this mode <ul style="list-style-type: none"> • MODE 1: OFF • MODE 2: 30 sec • MODE 3: 1 minute • MODE 4: 2 minutes • MODE 5: 3 minutes • MODE 6: 4 minutes • MODE 7: 5 minutes

A
B
C
D
E
F
G
H
I
J
K
L

PCS

N
O
P

DIAGNOSIS SYSTEM (BCM)

[POWER DISTRIBUTION SYSTEM]

< SYSTEM DESCRIPTION >

Monitor item	Description
HORN WITH KEYLESS LOCK	Horn reminder function mode by Intelligent Key button can be selected from the following with this mode <ul style="list-style-type: none"> • On: Operate • Off: Non-operation
PW DOWN SET	Unlock button pressing time on Intelligent Key button can be selected from the following with this mode <ul style="list-style-type: none"> • MODE 1: 3 sec • MODE 2: Non-operation • MODE 3: 5 sec

SELF-DIAG RESULT

Refer to [BCS-58. "DTC Index"](#).

DATA MONITOR

Monitor Item	Condition
REQ SW -DR	Indicates [On/Off] condition of door request switch (driver side)
REQ SW -AS	Indicates [On/Off] condition of door request switch (passenger side)
REQ SW -BD/TR	Indicates [On/Off] condition of back door request switch
PUSH SW	Indicates [On/Off] condition of push-button ignition switch
CLUTCH SW	NOTE: This item is displayed, but cannot be monitored
BRAKE SW 1	Indicates [On/Off]* condition of stop lamp switch power supply
BRAKE SW 2	Indicates [On/Off] condition of stop lamp switch
DETE/CANCL SW	Indicates [On/Off] condition of P position
SFT PN/N SW	Indicates [On/Off] condition of P or N position
S/L -LOCK	NOTE: This item is displayed, but cannot be monitored
S/L -UNLOCK	NOTE: This item is displayed, but cannot be monitored
S/L RELAY -F/B	NOTE: This item is displayed, but cannot be monitored
UNLK SEN -DR	Indicates [On/Off] condition of driver door UNLOCK status
PUSH SW -IPDM	Indicates [On/Off] condition of push-button ignition switch
IGN RLY1 -F/B	Indicates [On/Off] condition of ignition relay 1
DETE SW -IPDM	Indicates [On/Off] condition of P position
SFT PN -IPDM	Indicates [On/Off] condition of P or N position
SFT P -MET	Indicates [On/Off] condition of P position
SFT N -MET	Indicates [On/Off] condition of N position
ENGINE STATE	Indicates [Stop/Stall/Crank/Run] condition of engine states
S/L LOCK-IPDM	NOTE: This item is displayed, but cannot be monitored
S/L UNLK-IPDM	NOTE: This item is displayed, but cannot be monitored
S/L RELAY-REQ	NOTE: This item is displayed, but cannot be monitored
VEH SPEED 1	Display the vehicle speed signal received from combination meter by numerical value [km/h]
VEH SPEED 2	Display the vehicle speed signal received from ABS or VDC or TCM by numerical value [km/h]
DOOR STAT-DR	Indicates [LOCK/READY/UNLK] condition of unlock sensor
DOOR STAT-AS	Indicates [LOCK/READY/UNLK] condition of passenger side door status
ID OK FLAG	Indicates [Set/Reset] condition of key ID

DIAGNOSIS SYSTEM (BCM)

< SYSTEM DESCRIPTION >

[POWER DISTRIBUTION SYSTEM]

Monitor Item	Condition
PRMT ENG STRT	Indicates [Set/Reset] condition of engine start possibility
PRMT RKE STRT	NOTE: This item is displayed, but cannot be monitored
TRNK/HAT MNTR	NOTE: This item is displayed, but cannot be monitored
RKE-LOCK	Indicates [On/Off] condition of LOCK signal from Intelligent Key
RKE-UNLOCK	Indicates [On/Off] condition of UNLOCK signal from Intelligent Key
RKE-TR/BD	NOTE: This item is displayed, but cannot be monitored
RKE-PANIC	Indicates [On/Off] condition of PANIC button of Intelligent Key
RKE-MODE CHG	Indicates [On/Off] condition of MODE CHANGE signal from Intelligent Key
RKE OPE COUN1	When remote keyless entry receiver receives the signal transmitted while operating on Intelligent Key, the numerical value start changing
RKE OPE COUN2	NOTE: This item is displayed, but cannot be monitored

*: OFF is displayed when brake pedal is depressed while brake switch power supply is OFF.

ACTIVE TEST

Test item	Description
BATTERY SAVER	This test is able to check interior room lamp operation <ul style="list-style-type: none"> • On: Operate • Off: Non-operation
OUTSIDE BUZZER	This test is able to check Intelligent Key warning buzzer operation <ul style="list-style-type: none"> • On: Operate • Off: Non-operation
INSIDE BUZZER	This test is able to check warning chime in combination meter operation <ul style="list-style-type: none"> • Take Out: Take away warning chime sounds when CONSULT screen is touched • Key: Key warning chime sounds when CONSULT screen is touched • Knob: OFF position warning chime sounds when CONSULT screen is touched • Off: Non-operation
INDICATOR	This test is able to check warning lamp operation <ul style="list-style-type: none"> • KEY ON: "KEY" Warning lamp illuminates when CONSULT screen is touched • KEY IND: "KEY" Warning lamp blinks when CONSULT screen is touched • Off: Non-operation
INT LAMP	This test is able to check interior room lamp operation <ul style="list-style-type: none"> • On: Operate • Off: Non-operation
LCD	This test is able to check meter display information <ul style="list-style-type: none"> • Engine start information displays when "BP N" on CONSULT screen is touched • Engine start information displays when "BP I" on CONSULT screen is touched • Key ID warning displays when "ID NG" on CONSULT screen is touched • ROTAT: This item is displayed, but cannot be used. • P position warning displays when "SFT P" on CONSULT screen is touched • INSRT: This item is displayed, but cannot be monitored • BATT: This item is displayed, but cannot be monitored • Take away through window warning displays when "NO KY" on CONSULT screen is touched • Take away warning display when "OUTKEY" on CONSULT screen is touched • OFF position warning display when "LK WN" on CONSULT screen is touched
FLASHER	This test is able to check hazard warning lamp operation <ul style="list-style-type: none"> • LH: LH side hazard warning lamps operate • RH: RH side hazard warning lamps operate • Off: Non-operation

A
B
C
D
E
F
G
H
I
J
K
L

PCS

N
O
P

DIAGNOSIS SYSTEM (BCM)

[POWER DISTRIBUTION SYSTEM]

< SYSTEM DESCRIPTION >

Test item	Description
P RANGE	This test is able to check CVT shift selector power supply <ul style="list-style-type: none">• On: Operate• Off: Non-operation
ENGINE SW ILLUMI	This test is able to check push-button ignition switch illumination operation <ul style="list-style-type: none">• On: Operate• Off: Non-operation
LOCK INDICATOR	This test is able to check LOCK indicator (push-button ignition switch) operation <ul style="list-style-type: none">• On: Operate• Off: Non-operation
ACC INDICATOR	This test is able to check ACC indicator (push-button ignition switch) operation <ul style="list-style-type: none">• On: Operate• Off: Non-operation
IGNITION ON IND	This test is able to check ON indicator (push-button ignition switch) operation <ul style="list-style-type: none">• On: Operate• Off: Non-operation
HORN	This test is able to check horn operation <ul style="list-style-type: none">• On: Operate• Off: Non-operation
TRUNK/BACK DOOR	NOTE: This item is displayed, but cannot be used
POWER SLIDE DOOR	This test is able to check automatic sliding door operation <ul style="list-style-type: none">• RR PSD ON: Auto open/close operate• RL PSD ON: Auto open/close operate

ECU DIAGNOSIS INFORMATION

BCM

List of ECU Reference

INFOID:000000007050655

ECU	Reference
BCM	BCS-35. "Reference Value"
	BCS-57. "Fail-safe"
	BCS-57. "DTC Inspection Priority Chart"
	BCS-58. "DTC Index"

A
B
C
D
E
F
G
H
I
J
K
L
N
O
P

PCS

POWER DISTRIBUTION SYSTEM

< WIRING DIAGRAM >

[POWER DISTRIBUTION SYSTEM]

WIRING DIAGRAM

POWER DISTRIBUTION SYSTEM

Wiring Diagram

INFOID:000000007050656

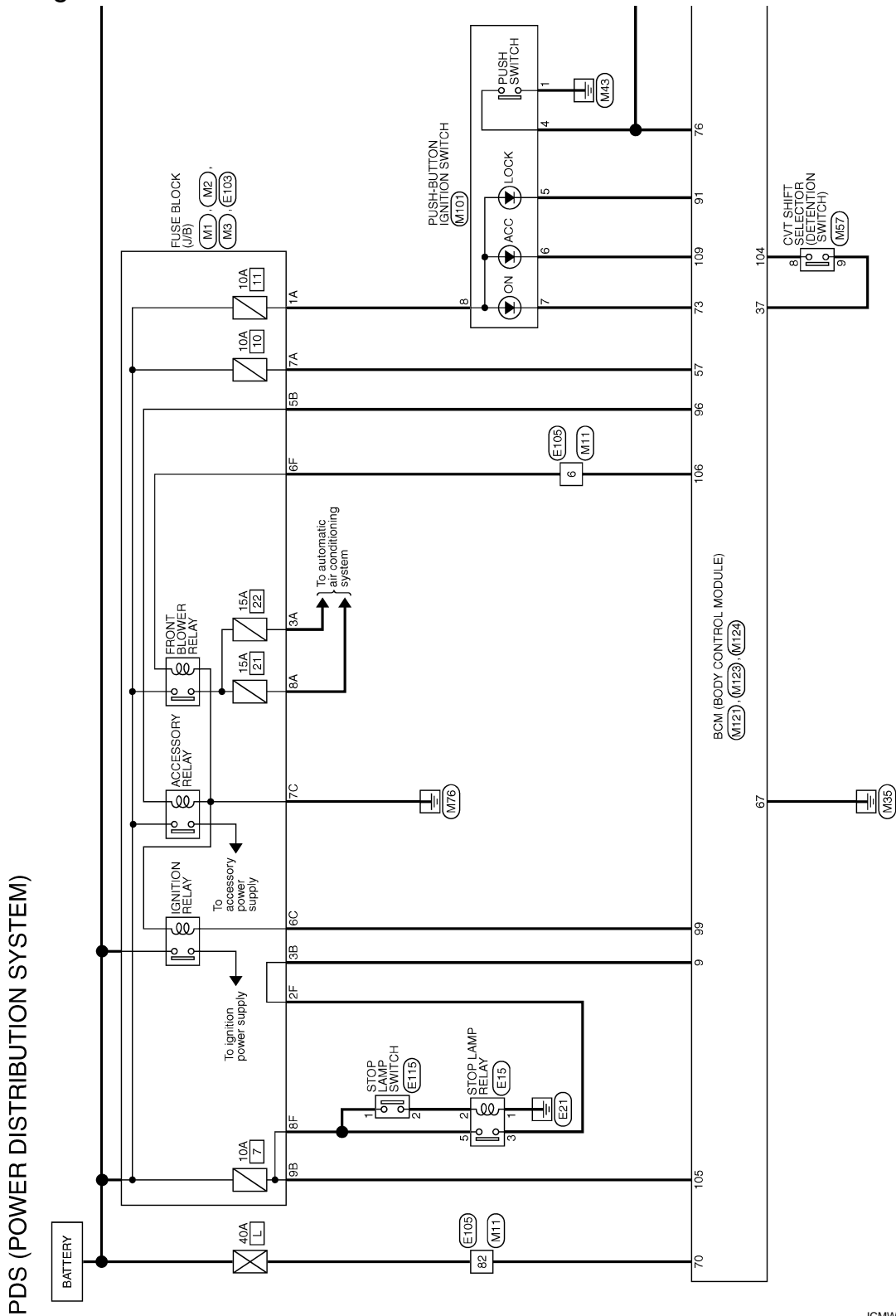

2010/12/13

JCMWA7673GB

POWER DISTRIBUTION SYSTEM

< WIRING DIAGRAM >

[POWER DISTRIBUTION SYSTEM]

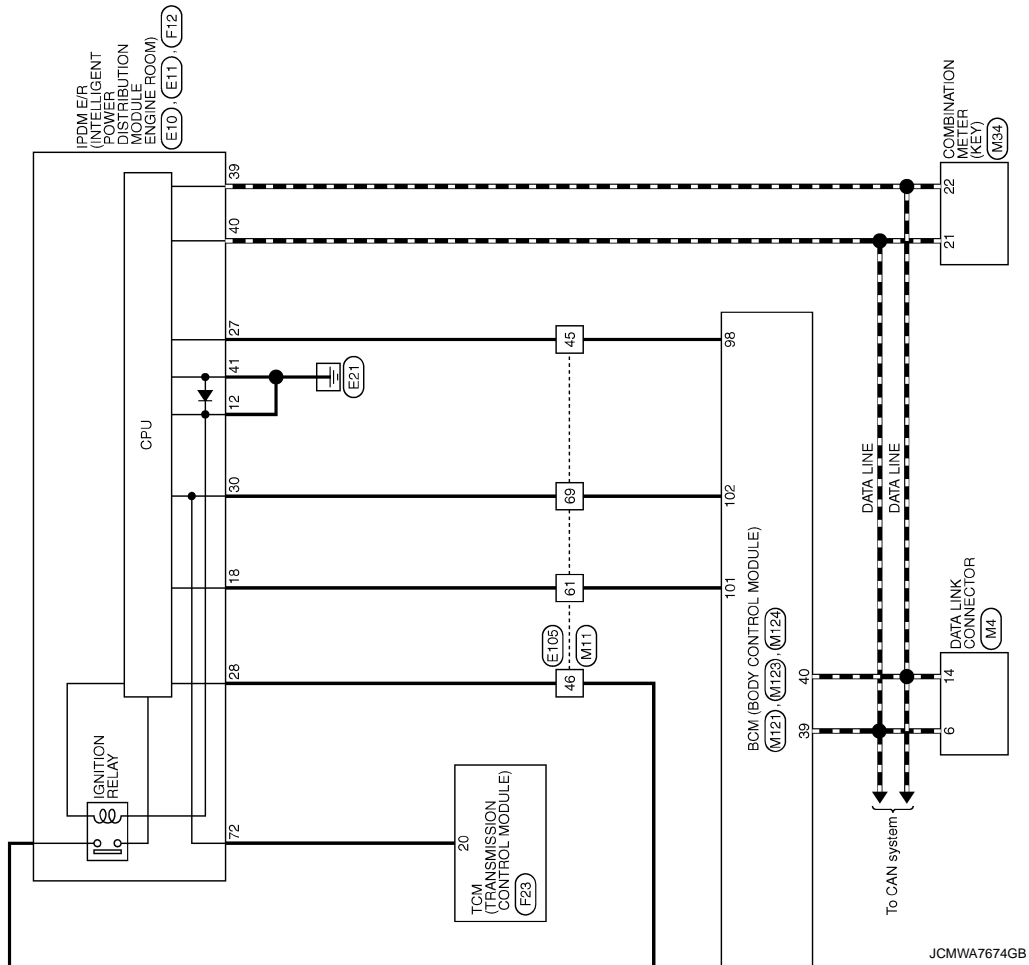

JCMWA7674GB

A
B
C
D
E
F
G
H
I
J
K
L
M
N
O
P

PCS

POWER DISTRIBUTION SYSTEM

< WIRING DIAGRAM >

[POWER DISTRIBUTION SYSTEM]

PDS (POWER DISTRIBUTION SYSTEM)

Connector No.	E10
Connector Name	IPDAE INTELLENT POWER DISTRIBUTION MODULE (FRAME ROOM)
Connector Type	TH08FV-M4-TV



Terminal No.	Color of Wire	Signal Name [Specification]
4	LG	-
5	Y	-
6	G	-
7	BR	-
10	P	-
12	B	-
13	G	-
15	L	-
16	R	-
18	P	-
19	V	-
20	W	-
21	O	-
22	SB	-
23	GR	-
24	G	-
25	GR	-
27	BR	-
28	G	-
30	LG	-
34	O	-
35	P	-
36	G	-
38	GR	-

Connector No.	E11
Connector Name	IPDAE INTELLENT POWER DISTRIBUTION MODULE (FRAME ROOM)
Connector Type	TH08FV-NH

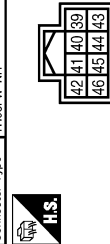

Terminal No.	Color of Wire	Signal Name [Specification]
38	P	-
40	L	-
41	B	-
42	SB	-
43	LG	-
44	W	-
45	Y	-
46	O	-

Connector No.	E15
Connector Name	STOP LAMP RELAY
Connector Type	MS02FL-M2-LC

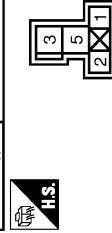

Terminal No.	Color of Wire	Signal Name [Specification]
1	B/W	-
2	LG	-
3	R	-
5	P	-

Connector No.	E103
Connector Name	FUSE BLOCK (J/B)
Connector Type	NS10FV-CS

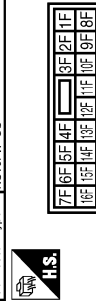

Terminal No.	Color of Wire	Signal Name [Specification]
1F	SB	-
2F	R	-
4F	L	-
6F	LG	-
8F	P	-
9F	BR	-

11F	G	-
12F	V	-

Connector No.	E105
Connector Name	WIRE TO WIRE
Connector Type	TH10MW-CS10-M3

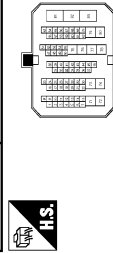

Terminal No.	Color of Wire	Signal Name [Specification]
6	LG	-
7	R	-
8	GR	-
9	SB	-
10	BR	-
11	Y	-
12	O	-
13	W	-
14	L	-
15	P	-
31	GR	-
32	R	-
33	W	-
37	BR	-
38	G	-
39	V	-
40	P	-
41	L	-
42	LG	-
43	O	-
45	GR	-
46	SB	-
47	V	-
49	L	-
51	BR	-
52	G	-
53	B	-
54	O	-
55	Y	-
56	SHIELD	-
61	P	-
62	G	-
63	W/L	-
64	L/O	-

66	W	-
67	Y	-
69	SB	-
70	LG	-
71	R	-
72	L	-
73	GR	-
74	Y	-
75	SB	-
76	Y	-
77	G	-
78	O	-
80	R	-
81	L	-
82	LG	-
83	R	-

Connector No.	E115
Connector Name	STOP LAMP SWITCH
Connector Type	MS04FV-LC



Terminal No.	Color of Wire	Signal Name [Specification]
1	P	-
2	LG	-
3	O	-
4	W	-

JCMWA7675GB

POWER DISTRIBUTION SYSTEM

< WIRING DIAGRAM >

[POWER DISTRIBUTION SYSTEM]

PDS (POWER DISTRIBUTION SYSTEM)

Connector No.	F12
Connector Name	SMALL INTELLIGENT POWER DISTRIBUTION MODULE FUSE BLOCK
Connector Type	TH20FW-CS12-M4

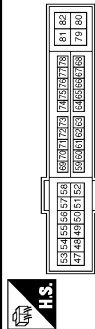

Terminal No.	Color of Wire	Signal Name [Specification]
48	W	-
49	R/B	-
51	LG	-
52	Y/G	-
53	R/W	-
54	G/W	-
55	W/L	-
56	R/Y	-
57	O	-
58	Y	-
69	W/B	-
70	O	-
71	P	-
72	R/B	-
75	LG	-
76	SB	-
77	B	-
80	B	-

Connector No.	F23
Connector Name	TCM (TRANSMISSION CONTROL MODULE) FUSE BLOCK
Connector Type	RH40FB-R28-L-RH

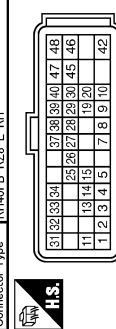

Terminal No.	Color of Wire	Signal Name [Specification]
1	P/B	TRANSMISSION RANGE SW 2
2	P/L	TRANSMISSION RANGE SW 3
3	G/O	TRANSMISSION RANGE SW 4
4	GR	TRANSMISSION RANGE SW 3 1MON

Terminal No.	Color of Wire	Signal Name [Specification]
5	B	GND
7	W	SENSOR GND
8	C/W	ROM ASSY (SEL 2)
9	L/R	ROM ASSY (SEL 1)
10	BR/R	ROM ASSY (SEL 3)
11	BR/W	TRANSMISSION RANGE SW 1
13	V	CVT FLUID TEMP SENSOR
14	R/W	PRI PRESS SENSOR
15	V/W	SEC PRESS SENSOR
19	G/B	BACK-UP LAMP RELAY
20	R/B	STARTER RELAY
25	W/R	SENSOR GND
26	L/O	SENSOR POWER
27	R/G	STEP MOTOR D
28	R	STEP MOTOR C
29	O/B	STEP MOTOR B
30	G/R	STEP MOTOR A
31	P	CAN-L
32	L	CAN-H
33	LG	PRI SPEED SENSOR
34	LG/R	SEC SPEED SENSOR
37	V/R	L/U SELECT SOL
38	L/W	TORQUE CONV CLUTCH SOL
39	W/B	SEG PRESS SOL
40	R/Y	LINE PRESS SOL
42	B	GND
46	Y	POWER SUPPLY
47	L/R	POWER SUPPLY (BUCK-UP)
48	Y	POWER SUPPLY

Connector No.	M1
Connector Name	FUSE BLOCK (J/B)
Connector Type	NS06FW-M2

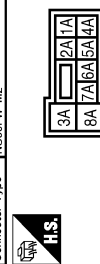

Terminal No.	Color of Wire	Signal Name [Specification]
1A	O	-
2A	G	-
3A	L	-
4A	GR	-
5A	V	-
7A	GR	-
8A	L	-

Connector No.	M2
Connector Name	FUSE BLOCK (J/B)
Connector Type	NS12FW-CS

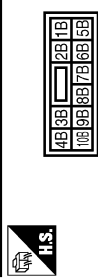

Terminal No.	Color of Wire	Signal Name [Specification]
3B	V	-
4B	W	-
5B	BR	-
6B	O	-
7B	R/L	-
8B	R	-
9B	C	-
11	SB	-
14	P	-
16	O	-

Connector No.	M3
Connector Name	FUSE BLOCK (J/B)
Connector Type	NS12FW-CS

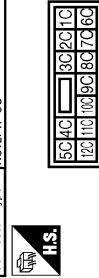

Terminal No.	Color of Wire	Signal Name [Specification]
9C	GR	-
7C	B/R	-
8C	G	-
9C	Y	-
10C	LG	-
11C	V	-
12C	Y	-

Connector No.	M4
Connector Name	DATA LINK CONNECTOR
Connector Type	BD16FW

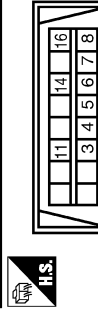

Terminal No.	Color of Wire	Signal Name [Specification]
3	LG	-
4	B/R	-
5	B/R	-
6	L	-
7	R	-
8	C	-
11	SB	-
14	P	-
16	O	-

A B C D E F G H I J K L N O P

PCS

JCMWA7676GB

POWER DISTRIBUTION SYSTEM

[POWER DISTRIBUTION SYSTEM]

< WIRING DIAGRAM >

PDS (POWER DISTRIBUTION SYSTEM)

Connector No.	M11
Connector Name	WIRE TO WIRE
Connector Type	TH70FW-CS10-M3

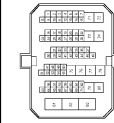

Terminal No.	Color of Wire	Signal Name [Specification]
6	O	-
7	G	-
8	G	-
9	B	-
10	R	-
11	W	-
12	LG	-
13	Y	-
14	L	-
15	P	-
31	R	-
32	V	-
33	Y	-
37	BR	-
38	BR	-
39	Y	-
40	P	-
41	L	-
42	G	-
43	W	-
45	LG	-
46	V	-
47	LG	-
49	G	-
51	SB	-
52	GR	-
53	B	-
54	R	-
55	L	-
56	SHIELD	-
61	BR	-
62	LG	-
63	W/L	-
64	L/O	-
66	O	-
67	SB	-
68	Y	-
70	R	-

71	R	-
72	L	-
73	R	-
74	Y	-
75	G	-
76	V	-
77	P	-
78	W	-
80	Y	-
81	W	-
82	L	-
83	R	-

Connector No.	M34
Connector Name	COMBINATION METER
Connector Type	TH40FW-NH



1	2	3	4	5	6	7	8	9	10	11	12	13	14	15	16	17	18	19	20
21	22	23	24	25	26	27	28	29	30	31	32	33	34	35	36	37	38	39	40

Terminal No.	Color of Wire	Signal Name [Specification]
1	O	BATTERY POWER SUPPLY
2	Y	IGNITION SIGNAL
3	B	GROUND
4	B	GROUND
5	B/P	ILLUMINATION CONTROL SIGNAL
8	SB	TRIP RESET SWITCH SIGNAL
10	P	METER CONTROL SWITCH GROUND
11	G	ENTER SWITCH SIGNAL
12	BR	SELECT SWITCH SIGNAL
13	Y	ILLUMINATION CONTROL SWITCH SIGNAL (+)
14	V	ILLUMINATION CONTROL SWITCH SIGNAL (-)
15	BR	AIR BAG SIGNAL
16	L	ENGINE COOLANT TEMPERATURE SIGNAL
18	LG	AMBIENT SENSOR SIGNAL
19	R	A/C AUTO AMP CONNECTION RECOGNITION SIGNAL
20	Y	AMBIENT SENSOR GROUND
21	L	CAN-H
22	P	GROUND
23	B	GROUND
24	B	FUEL LEVEL SENSOR GROUND
25	BR	ALTERNATOR SIGNAL
26	BR	PARKING BRAKE SWITCH SIGNAL
27	Y	BRAKE FLUID LEVEL SWITCH SIGNAL
28	V	SECURITY SIGNAL

29	G	WASHER LEVEL SWITCH SIGNAL
31	SB	VEHICLE SPEED SIGNAL (8-PUL SE)
32	P	OVERDRIVE CONTROL SWITCH SIGNAL
33	O	FUEL LEVEL SENSOR SIGNAL
34	P	SEAT BELT BUCKLE SWITCH SIGNAL (DRIVERS SIDE)
35	BR	PASSENGER SEAT BELT WARNING SIGNAL

Connector No.	M57
Connector Name	CVT SHIFT SELECTOR
Connector Type	TH12FW-NH



6	5	4	3	2	1
9	8	7	6	5	4

Terminal No.	Color of Wire	Signal Name [Specification]
1	P	-
4	B/R	-
6	O	-
7	B	-
8	L	-
9	G	-

Connector No.	M101
Connector Name	PUSH-BUTTON IGNITION SWITCH
Connector Type	TK08FBR



1	2	3
4	5	6
7	8	9

Terminal No.	Color of Wire	Signal Name [Specification]
1	B/W	-
2	G	-
3	P	-
4	V	-
5	SB	-
6	GR	-
7	Y	-
8	O	-

Connector No.	M121
Connector Name	BCM (BODY CONTROL MODULE)
Connector Type	TH40FB-NH



1	2	3	4	5	6	7	8	9	10	11	12	13	14	15	16	17	18	19	20
21	22	23	24	25	26	27	28	29	30	31	32	33	34	35	36	37	38	39	40

Terminal No.	Color of Wire	Signal Name [Specification]
1	W	REAR WINDOW DEF RELAY GOVT
2	LG	COMBI SW INPUT 5
3	Y	COMBI SW INPUT 4
4	O	COMBI SW INPUT 3
5	G	COMBI SW INPUT 2
6	L	COMBI SW INPUT 1
7	W	KEY C/L UNLOCK SW
8	Y	KEY C/L LOCK SW (Without automatic sliding door)
8	GR	PW SW COMM (With automatic sliding door)
9	V	STOP LAMP SW 1
12	GR	DOOR LK & UNLK SW LOCK
13	BR	DOOR LK & UNLK SW UNLOCK
14	L	OPTICAL SENS
15	W	REAR WINDOW DEF SW
16	Y	DIMMER
17	O	SENS PWR SPLY
18	R	RECEIV/SENS GND
21	R	NATS ANT AMP
23	V	SECURITY IND GOVT
24	B	DONGLE LINK
25	W	NATS ANT AMP
27	O	A/C ON
28	BR	BLOWER FAN ON
29	P	HAZARD SW
30	L	BK DOOR OPNR SW
31	O	DF DOOR UNLK SENS
32	Y	COMBI SW OUTPUT 5
33	W	COMBI SW OUTPUT 4
34	GR	COMBI SW OUTPUT 3
35	SB	COMBI SW OUTPUT 2
36	R	COMBI SW OUTPUT 1
37	G	DEFENT SW
38	SB	RECEIVER COMM
39	L	CAN-H
40	P	CAN-L

POWER DISTRIBUTION SYSTEM

< WIRING DIAGRAM >

[POWER DISTRIBUTION SYSTEM]

A
B
C
D
E
F
G
H
I
J
K
L
N
O
P

PDS (POWER DISTRIBUTION SYSTEM)

Connector No.	M123
Connector Name	BCM (BODY CONTROL MODULE)
Connector Type	FEA3PFI-FHA8-SA



56	57	58	59	60	61	62	63	64
65	66	67	68	69	70			

Terminal No.	Color of Wire	Signal Name (Specification)
56	P	INT ROOM LAMP PWR SPLY
57	GR	BAT
58	O	AIR BAG
59	SB	PASS DOOR UNLK OUTPUT
60	V	TURN SIG LH OUTPUT
61	G	TURN SIG RH OUTPUT
62	W	STEP LAMP-CONT
63	R	INT ROOM LAMP-CONT
64	LG	CRANK REQ
65	V	ALL DOOR LOCK OUTPUT
66	G	DR DOOR UNLK OUTPUT
67	B	GND
68	L	PW PWR SPLY (IGN)
69	P	PW PWR SPLY (BAT)
70	L	BAT



71	72	73	74	75	76	77	78	79	80	81
82	83	84	85	86	87	88	89	90	91	92

Connector No.	M124
Connector Name	BCM (BODY CONTROL MODULE)
Connector Type	TH40FY-RH

Terminal No.	Color of Wire	Signal Name (Specification)
73	Y	ON IND
75	SB	DR DOOR REQ SW
76	V	PUSH SW
78	P	DR DOOR ANT+
79	V	DR DOOR ANT-
80	R	PASS DOOR ANT+
81	L	PASS DOOR ANT-

82	G	REAR BMRPZ ANT+
83	R	REAR BMRPZ ANT-
84	Y	ROOM ANTI+
85	BR	ROOM ANTI-
86	LG	ROOM ANTI2+
87	V	ROOM ANTI2-
88	W	Luggage ROOM ANT+
89	B	Luggage ROOM ANT-
90	P	PUSH-BTN IGN SW ILL-PWR SPLY
91	SB	LOCK IND
92	G	PUSH-BTN IGN SW ILL GND
93	R	I-KEY WARN BUZZER
96	BR	ACC RELAY CONT OUTPUT
97	W	STARTER RELAY CONT
98	LG	IGN RELAY (PDM E/R) CONT
99	GR	IGN RELAY (F/B) CONT OUTPUT
100	GR	PASS DOOR REQ SW
101	BR	IGN PWR SPLY 2
102	Y	P/N POSITION
104	L	CVT SHFT SELECT PWR SPLY
105	GR	STOP LAMP SW 2
106	O	BLWR RELAY CONT OUTPUT
109	GR	ACC IND

JCMWA7678GB



DIAGNOSIS AND REPAIR WORK FLOW

< BASIC INSPECTION >

[POWER DISTRIBUTION SYSTEM]

BASIC INSPECTION

DIAGNOSIS AND REPAIR WORK FLOW

Work Flow

INFOID:000000007050657

OVERALL SEQUENCE

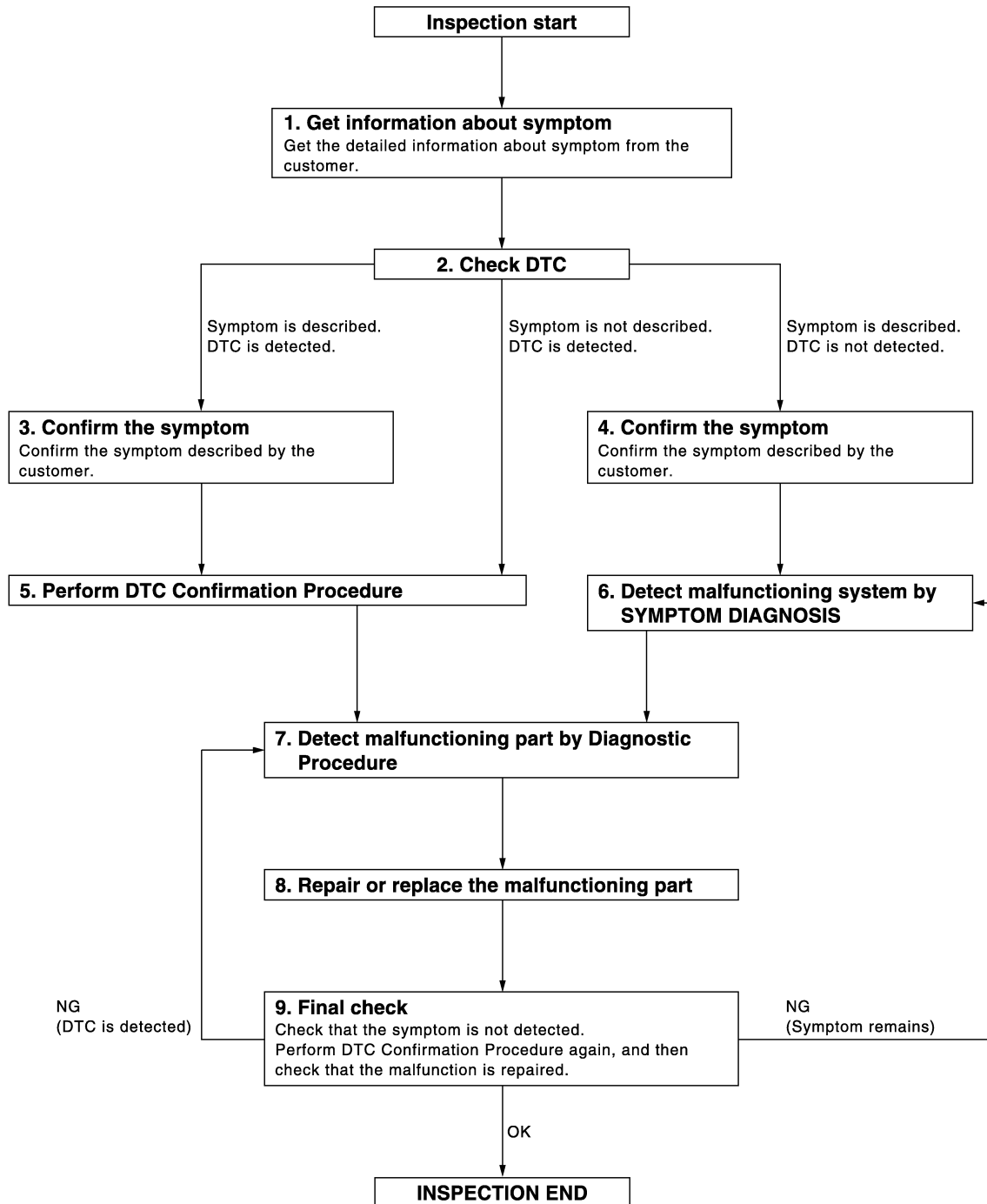

DETAILED FLOW

JMKIA3449GB

DIAGNOSIS AND REPAIR WORK FLOW

< BASIC INSPECTION >

[POWER DISTRIBUTION SYSTEM]

1.GET INFORMATION ABOUT SYMPTOM

Get detailed information from the customer about the symptom (the condition and the environment when the incident/malfunction occurs).

>> GO TO 2.

2.CHECK DTC

1. Check DTC for BCM and IPDM E/R.
2. Perform the following procedure if DTC is displayed.
 - Record DTC and freeze frame data (Print them out with CONSULT.)
 - Erase DTC.
 - Study the relationship between the cause detected by DTC and the symptom described by the customer.
3. Check related service bulletins for information.

Are any symptoms described and any DTC detected?

- Symptom is described, DTC is displayed>>GO TO 3.
- Symptom is described, DTC is not displayed>>GO TO 4.
- Symptom is not described, DTC is displayed>>GO TO 5.

3.CONFIRM THE SYMPTOM

Confirm the symptom described by the customer.
Connect CONSULT to the vehicle in the "DATA MONITOR" mode and check real time diagnosis results.
Verify relation between the symptom and the condition when the symptom is detected.

>> GO TO 5.

4.CONFIRM THE SYMPTOM

Confirm the symptom described by the customer.
Connect CONSULT to the vehicle in the "DATA MONITOR" mode and check real time diagnosis results.
Verify relation between the symptom and the condition when the symptom is detected.

>> GO TO 6.

5.PERFORM DTC CONFIRMATION PROCEDURE

Perform DTC Confirmation Procedure for the displayed DTC, and then check that DTC is detected again.
At this time, always connect CONSULT to the vehicle, and check diagnostic results in real time.
If two or more DTCs are detected, refer to [BCS-57. "DTC Inspection Priority Chart"](#), and determine trouble diagnosis order.

NOTE:

Perform Component Function Check if DTC Confirmation Procedure is not included in Service Manual. This simplified check procedure is an effective alternative, although DTC cannot be detected during this check.
If the result of Component Function Check is NG, it is the same as the detection of DTC by DTC Confirmation Procedure.

Is DTC detected?

- YES >> GO TO 7.
- NO >> Refer to [GI-42. "Intermittent Incident"](#).

6.DETECT MALFUNCTIONING SYSTEM BY SYMPTOM DIAGNOSIS

Detect malfunctioning system according to SYMPTOM DIAGNOSIS based on the confirmed symptom in step 4, and determine the trouble diagnosis order based on possible causes and symptom.

>> GO TO 7.

7.DETECT MALFUNCTIONING PART BY DIAGNOSTIC PROCEDURE

Inspect according to Diagnostic Procedure of the system.

NOTE:

The Diagnostic Procedure described based on open circuit inspection. A short circuit inspection is also required for the circuit check in the Diagnostic Procedure.

A
B
C
D
E
F
G
H
I
J
K
L
N
O
P

PCS

DIAGNOSIS AND REPAIR WORK FLOW

[POWER DISTRIBUTION SYSTEM]

< BASIC INSPECTION >

Is malfunctioning part detected?

YES >> GO TO 8.

NO >> Check voltage of related BCM terminals using CONSULT.

8. REPAIR OR REPLACE THE MALFUNCTIONING PART

1. Repair or replace the malfunctioning part.
2. Reconnect parts or connectors disconnected during Diagnostic Procedure again after repair and replacement.
3. Check DTC. If DTC is displayed, erase it.

>> GO TO 9.

9. FINAL CHECK

When DTC was detected in step 2, perform DTC Confirmation Procedure or Component Function Check again, and then check that the malfunction is repaired securely.

When symptom was described by the customer, refer to confirmed symptom in step 3 or 4, and check that the symptom is not detected.

Does the symptom reappear?

YES (DTC is detected)>>GO TO 7.

YES (Symptom remains)>>GO TO 6.

NO >> INSPECTION END

B2614 ACC RELAY CIRCUIT

< DTC/CIRCUIT DIAGNOSIS >

[POWER DISTRIBUTION SYSTEM]

DTC/CIRCUIT DIAGNOSIS

B2614 ACC RELAY CIRCUIT

DTC Logic

INFOID:000000007161360

DTC DETECTION LOGIC

DTC No.	Trouble diagnosis name	DTC detecting condition	Possible cause
B2614	BCM	The following status are compared, and it does not agree for 1 second or more. <ul style="list-style-type: none"> State of accessory relay control judgment in BCM State of accessory relay control signal 	<ul style="list-style-type: none"> Harness or connectors (Accessory relay control signal circuit) BCM Accessory relay

DTC CONFIRMATION PROCEDURE

1. PERFORM DTC CONFIRMATION PROCEDURE

- Turn ignition switch to ACC, and wait for 1 second or more.
- Check "Self-diagnosis result" of BCM with CONSULT.

Is DTC detected?

- YES >> Go to [PCS-55. "Diagnosis Procedure"](#).
NO >> INSPECTION END

Diagnosis Procedure

INFOID:000000007161361

1. CHECK ACCESSORY RELAY CONTROL SIGNAL

Check voltage between BCM harness connector and ground.

(+)		(-)	Condition	Voltage (V) (Approx.)	
BCM					
Connector	Terminal				
M124	96	Ground	Ignition switch	OFF ACC or ON	0 - 0.5 9 - 16

Is the inspection result normal?

- YES >> Replace BCM. Refer to [BCS-82. "Removal and Installation"](#).
NO >> GO TO 2.

2. CHECK ACCESSORY RELAY CONTROL SIGNAL CIRCUIT

- Turn ignition switch OFF.
- Disconnect BCM connector and accessory relay.
- Check continuity between BCM harness connector and accessory relay harness connector.

BCM		Accessory relay	Continuity
Connector	Terminal	Terminal	
M124	96	Coil upstream side	Existed

- Check continuity between BCM harness connector and ground.

BCM		Ground	Continuity
Connector	Terminal		
M124	96		Not existed

Is the inspection result normal?

- YES >> GO TO 3.
NO >> Repair or replace harness.

B2614 ACC RELAY CIRCUIT

[POWER DISTRIBUTION SYSTEM]

< DTC/CIRCUIT DIAGNOSIS >

3. CHECK ACCESSORY RELAY

Refer to [PCS-56. "Component Inspection"](#).

Is the inspection result normal?

- YES >> Replace BCM. Refer to [BCS-82. "Removal and Installation"](#).
- NO >> Replace accessory relay.

Component Inspection

INFOID:000000007161362

1. CHECK ACCESSORY RELAY

1. Turn ignition switch OFF.
2. Remove accessory relay.
3. Check the continuity between accessory relay terminals.

Terminals	Condition	Continuity
3 and 5	12 V direct current supply between terminals 1 and 2	Existed
	No current supply	Not existed

Is the inspection result normal?

- YES >> INSPECTION END
- NO >> Replace accessory relay

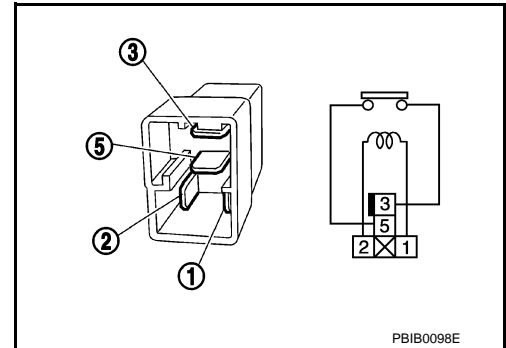

PBIB0098E

B2615 BLOWER RELAY CIRCUIT

< DTC/CIRCUIT DIAGNOSIS >

[POWER DISTRIBUTION SYSTEM]

B2615 BLOWER RELAY CIRCUIT

DTC Logic

INFOID:000000007161363

DTC DETECTION LOGIC

DTC No.	Trouble diagnosis name	DTC detecting condition	Possible cause
B2616	BCM	The following status are compared, and it does not agree for 1 second or more. <ul style="list-style-type: none"> State of blower relay control judgment in BCM State of blower relay control signal 	<ul style="list-style-type: none"> Harness or connectors (Blower relay control signal circuit) BCM Blower relay

DTC CONFIRMATION PROCEDURE

1. PERFORM DTC CONFIRMATION PROCEDURE

- Turn ignition switch ON, and wait for 1 second or more.
- Check "Self-diagnosis result" with CONSULT.

Is DTC detected?

- YES >> Go to [PCS-59. "Diagnosis Procedure"](#).
 NO >> INSPECTION END

Diagnosis Procedure

INFOID:000000007161364

1. CHECK BLOWER RELAY CONTROL SIGNAL

Check voltage between BCM harness connector and ground.

(+)		(-)	Condition	Voltage (V) (Approx.)	
BCM					
Connector	Terminal				
M124	106	Ground	Ignition switch	OFF or ACC	0 - 0.5
				ON	9 - 16

Is the inspection result normal?

- YES >> Replace BCM. Refer to [BCS-82. "Removal and Installation"](#).
 NO >> GO TO 2.

2. CHECK BLOWER RELAY CONTROL SIGNAL CIRCUIT

- Turn ignition switch OFF.
- Disconnect BCM connector and blower relay.
- Check continuity between BCM harness connector and blower relay harness connector.

BCM		Blower relay		Continuity
Connector	Terminal	Terminal		
M124	106	Coil upstream side		Existed

- Check continuity between BCM harness connector and ground.

BCM		Ground	Continuity
Connector	Terminal		
M124	106		Not existed

Is the inspection result normal?

- YES >> GO TO 3.
 NO >> Repair or replace harness.

3. CHECK BLOWER RELAY

Refer to [PCS-56. "Component Inspection"](#).

A

B

C

D

E

F

G

H

I

J

K

L

PCS

N

O

P

B2615 BLOWER RELAY CIRCUIT

[POWER DISTRIBUTION SYSTEM]

< DTC/CIRCUIT DIAGNOSIS >

Is the inspection result normal?

YES >> Replace BCM. Refer to [BCS-82. "Removal and Installation"](#).

NO >> Replace blower relay.

Component Inspection

INFOID:000000007161365

1. CHECK BLOWER RELAY

1. Turn blower switch OFF.
2. Remove blower relay.
3. Check the continuity between blower relay terminals.

Terminals	Condition	Continuity
3 and 5	12 V direct current supply between terminals 1 and 2	Existed
	No current supply	Not existed

Is the inspection result normal?

YES >> INSPECTION END

NO >> Replace blower relay

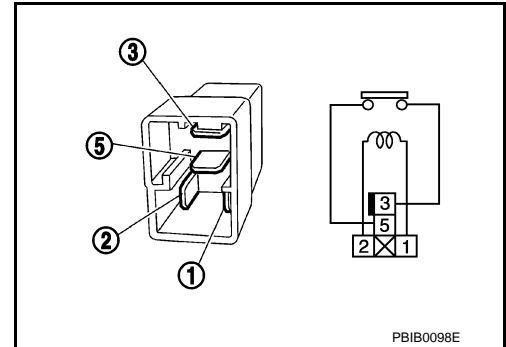

B2616 IGNITION RELAY CIRCUIT

< DTC/CIRCUIT DIAGNOSIS >

[POWER DISTRIBUTION SYSTEM]

B2616 IGNITION RELAY CIRCUIT

DTC Logic

INFOID:000000007161366

DTC DETECTION LOGIC

DTC No.	Trouble diagnosis name	DTC detecting condition	Possible cause
B2616	BCM	The following status are compared, and it does not agree for 1 second or more. <ul style="list-style-type: none"> State of ignition relay (fuse block) control judgment in BCM State of ignition relay (fuse block) control signal 	<ul style="list-style-type: none"> Harness or connectors [Ignition relay (fuse block) control signal circuit] BCM Ignition relay (fuse block)

DTC CONFIRMATION PROCEDURE

1. PERFORM DTC CONFIRMATION PROCEDURE

- Turn ignition switch ON, and wait for 1 second or more.
- Check "Self-diagnosis result" with CONSULT.

Is DTC detected?

- YES >> Go to [PCS-59. "Diagnosis Procedure"](#).
NO >> INSPECTION END

Diagnosis Procedure

INFOID:000000007161367

1. CHECK IGNITION RELAY (FUSE BLOCK) CONTROL SIGNAL

Check voltage between BCM harness connector and ground.

(+)		(-)	Condition	Voltage (V) (Approx.)	
BCM					
Connector	Terminal				
M124	99	Ground	Ignition switch	OFF or ACC	0 - 0.5
				ON	9 - 16

Is the inspection result normal?

- YES >> Replace BCM. Refer to [BCS-82. "Removal and Installation"](#).
NO >> GO TO 2.

2. CHECK IGNITION RELAY (FUSE BLOCK) CONTROL SIGNAL CIRCUIT

- Turn ignition switch OFF.
- Disconnect BCM connector and ignition relay (fuse block).
- Check continuity between BCM harness connector and ignition relay (fuse block) harness connector.

BCM		Ignition relay (fuse block)	Continuity
Connector	Terminal	Terminal	
M124	99	Coil upstream side	Existed

- Check continuity between BCM harness connector and ground.

BCM		Ground	Continuity
Connector	Terminal		
M124	99		Not existed

Is the inspection result normal?

- YES >> GO TO 3.
NO >> Repair or replace harness.

3. CHECK IGNITION RELAY (FUSE BLOCK)

A

B

C

D

E

F

G

H

I

J

K

L

PCS

N

O

P

B2616 IGNITION RELAY CIRCUIT

[POWER DISTRIBUTION SYSTEM]

< DTC/CIRCUIT DIAGNOSIS >

Refer to [PCS-56. "Component Inspection"](#).

Is the inspection result normal?

- YES >> Replace BCM. Refer to [BCS-82. "Removal and Installation"](#).
- NO >> Replace ignition relay (fuse block).

Component Inspection

INFOID:000000007161368

1. CHECK IGNITION RELAY

1. Turn ignition switch OFF.
2. Remove ignition relay.
3. Check the continuity between ignition relay terminals.

Terminals	Condition	Continuity
3 and 5	12 V direct current supply between terminals 1 and 2	Existed
	No current supply	Not existed

Is the inspection result normal?

- YES >> INSPECTION END
- NO >> Replace ignition relay

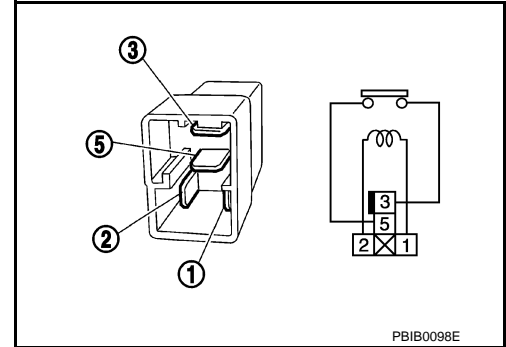

B2618 BCM

< DTC/CIRCUIT DIAGNOSIS >

[POWER DISTRIBUTION SYSTEM]

B2618 BCM

DTC Logic

INFOID:000000007161369

DTC DETECTION LOGIC

DTC No.	Trouble diagnosis name	DTC detecting condition	Possible cause
B2618	BCM	The following status are compared, and it does not agree for 1 second or more. <ul style="list-style-type: none"> State of ignition relay (IPDM E/R) control judgment in BCM State of ignition relay (IPDM E/R) control signal 	<ul style="list-style-type: none"> Harness or connectors [Ignition relay (IPDM E/R) control signal circuit] BCM IPDM E/R

DTC CONFIRMATION PROCEDURE

1. PERFORM DTC CONFIRMATION PROCEDURE

- Turn ignition switch ON, and wait for 1 second or more.
- Check "Self-diagnosis result" of BCM with CONSULT.

Is DTC detected?

- YES >> Go to [PCS-61. "Diagnosis Procedure"](#).
 NO >> INSPECTION END

Diagnosis Procedure

INFOID:000000007161370

1. CHECK IGNITION RELAY (IPDM E/R) CONTROL SIGNAL

Check voltage between BCM harness connector and ground.

(+)		(-)	Condition	Voltage (V) (Approx.)	
BCM					
Connector	Terminal				
M124	98	Ground	Ignition switch	OFF or ACC	9 - 16
				ON	0 - 0.5

Is the inspection result normal?

- YES >> Replace BCM. Refer to [BCS-82. "Removal and Installation"](#).
 NO >> GO TO 2.

2. CHECK IGNITION RELAY (IPDM E/R) CONTROL SIGNAL CIRCUIT

- Turn ignition switch OFF.
- Disconnect BCM connector and IPDM E/R.
- Check continuity between BCM harness connector and IPDM E/R harness connector.

PCS

BCM		IPDM E/R		Continuity
Connector	Terminal	Connector	Terminal	
M124	98	E10	27	Existed

- Check continuity between BCM harness connector and ground.

BCM		Ground	Continuity
Connector	Terminal		
M124	98		Not existed

Is the inspection result normal?

- YES >> GO TO 3.
 NO >> Repair or replace harness.

3. CHECK VOLTAGE OF IGNITION RELAY (IPDM E/R) CONTROL SIGNAL CIRCUIT (IPDM E/R SIDE)

B2618 BCM

< DTC/CIRCUIT DIAGNOSIS >

[POWER DISTRIBUTION SYSTEM]

1. Connect IPDM E/R connector.
2. Check voltage between IPDM E/R harness connector and ground.

(+)		(-)	Condition		Voltage (V) (Approx.)
IPDM E/R					
Connector	Terminal				
E10	27	Ground	Ignition switch	OFF	9 - 16

Is the inspection result normal?

- YES >> Replace BCM. Refer to [BCS-82, "Removal and Installation"](#).
- NO >> Replace IPDM E/R.

B261A PUSH-BUTTON IGNITION SWITCH

< DTC/CIRCUIT DIAGNOSIS >

[POWER DISTRIBUTION SYSTEM]

B261A PUSH-BUTTON IGNITION SWITCH

DTC Logic

INFOID:000000007161371

DTC DETECTION LOGIC

DTC No.	Trouble diagnosis name	DTC detecting condition	Possible cause
B261A	PUSH-BTN IGN SW	The following signal status that BCM receives are compared, and it does not agree for 1 second or more. <ul style="list-style-type: none"> Push-button Ignition switch (push switch) signal Push-button Ignition switch (push switch) status signal (CAN) 	<ul style="list-style-type: none"> Harness or connectors [Push-button Ignition switch (push switch) circuit] BCM IPDM E/R

DTC CONFIRMATION PROCEDURE

1. PERFORM DTC CONFIRMATION PROCEDURE

- Press push-button ignition switch (push switch) under the following conditions, and wait for 1 second or more.
 - Shift position is in the P position
 - Do not depress brake pedal
- Check "Self-diagnosis result" of BCM with CONSULT.

Is DTC detected?

- YES >> Go to [PCS-63, "Diagnosis Procedure"](#).
NO >> INSPECTION END

Diagnosis Procedure

INFOID:000000007161372

1. CHECK PUSH-BUTTON IGNITION SWITCH (PUSH SWITCH) OUTPUT SIGNAL

- Disconnect push-button ignition switch connector and IPDM E/R connector.
- Check voltage between push-button ignition switch harness connector and ground.

(+)		(-)	Voltage (V) (Approx.)
Push-button Ignition switch			
Connector	Terminal		
M101	4	Ground	9 - 16

Is the inspection result normal?

- YES >> GO TO 3.
NO >> GO TO 2.

2. CHECK PUSH-BUTTON IGNITION SWITCH CIRCUIT (BCM)

- Disconnect BCM connector.
- Check continuity between BCM harness connector and push-button ignition switch harness connector.

BCM		Push-button Ignition switch		Continuity
Connector	Terminal	Connector	Terminal	
M124	76	M101	4	Existed

- Check continuity between push-button ignition switch harness connector and ground.

Push-button Ignition switch		Ground	Continuity
Connector	Terminal		
M101	4		Not existed

Is the inspection result normal?

- YES >> Replace BCM. Refer to [BCS-82, "Removal and Installation"](#).

B261A PUSH-BUTTON IGNITION SWITCH

[POWER DISTRIBUTION SYSTEM]

< DTC/CIRCUIT DIAGNOSIS >

NO >> Repair or replace harness.

3. CHECK PUSH-BUTTON IGNITION SWITCH (PUSH SWITCH) OUTPUT SIGNAL (IPDM E/R)

Check voltage between IPDM E/R harness connector and ground.

(+)		(-)	Voltage (V) (Approx.)
IPDM E/R			
Connector	Terminal		
E10	28	Ground	9 - 16

Is the inspection result normal?

YES >> Replace IPDM E/R.

NO >> GO TO 4.

4. CHECK PUSH-BUTTON IGNITION SWITCH (PUSH SWITCH) CIRCUIT (IPDM E/R)

1. Disconnect BCM connector.
2. Check continuity between IPDM E/R harness connector and push-button ignition switch harness connector.

IPDM E/R		Push-button Ignition switch		Continuity
Connector	Terminal	Connector	Terminal	
E10	28	M101	4	Existed

3. Check continuity between push-button ignition switch harness connector and ground.

Push-button Ignition switch		Ground	Continuity
Connector	Terminal		
M101	4		Not existed

Is the inspection result normal?

YES >> GO TO 5.

NO >> Repair or replace harness.

5. CHECK INTERMITTENT INCIDENT

Refer to [GI-42, "Intermittent Incident"](#).

>> INSPECTION END

B26F1 IGNITION RELAY

< DTC/CIRCUIT DIAGNOSIS >

[POWER DISTRIBUTION SYSTEM]

B26F1 IGNITION RELAY

DTC Logic

INFOID:000000007161373

DTC DETECTION LOGIC

DTC No.	Trouble diagnosis name	DTC detecting condition	Possible cause
B26F1	IGN RELAY OFF	BCM transmits the ignition relay control signal (ON: 0 V) or ignition switch ON signal (ON) (CAN), but does not receives ignition switch ON signal (ON) (CAN) from IPDM E/R.	<ul style="list-style-type: none"> Harness or connectors (Ignition relay circuit is open) BCM IPDM E/R

DTC CONFIRMATION PROCEDURE

1. PERFORM DTC CONFIRMATION PROCEDURE

- Turn ignition switch ON, and wait for 2 seconds or more.
- Check "Self-diagnosis result" with CONSULT.

Is DTC detected?

- YES >> Go to [PCS-65. "Diagnosis Procedure"](#).
 NO >> INSPECTION END

Diagnosis Procedure

INFOID:000000007161374

1. CHECK IPDM E/R SELF-DIAGNOSTIC RESULT

- Turn ignition switch ON.
- Erase the DTC of IPDM E/R.
- Turn ignition switch OFF.
- Turn ignition switch ON and check the DTC again.

Is DTC detected?

- YES >> Repair or replace the malfunctioning part. Refer to [PCS-24. "DTC Index"](#).
 NO >> GO TO 2.

2. CHECK IGNITION RELAY (IPDM E/R) CONTROL SIGNAL

Check voltage between BCM harness connector and ground.

(+)		(-)	Condition		Voltage (V) (Approx.)
BCM					
Connector	Terminal	Ground	Ignition switch	ON	0 - 0.5
M124	98				

PCS

Is the inspection result normal?

- YES >> GO TO 3.
 NO >> Replace BCM. Refer to [BCS-82. "Removal and Installation"](#).

3. CHECK IGNITION RELAY (IPDM E/R) CONTROL SIGNAL CIRCUIT

- Turn ignition switch OFF.
- Disconnect BCM and IPDM connectors.
- Check continuity between BCM harness connector and IPDM E/R harness connector.

BCM		IPDM E/R		Continuity
Connector	Terminal	Connector	Terminal	
M124	98	E10	27	Existed

Is the inspection result normal?

- YES >> Replace IPDM E/R.
 NO >> Repair or replace harness.

B26F2 IGNITION RELAY

< DTC/CIRCUIT DIAGNOSIS >

[POWER DISTRIBUTION SYSTEM]

B26F2 IGNITION RELAY

DTC Logic

INFOID:000000007161375

DTC DETECTION LOGIC

DTC No.	Trouble diagnosis name	DTC detecting condition	Possible cause
B26F2	IGN RELAY ON	BCM transmits the ignition relay control signal (OFF: 12 V) or ignition switch ON signal (OFF) (CAN), but does not receives ignition switch ON signal (OFF) (CAN) from IPDM E/R.	<ul style="list-style-type: none"> • Harness or connectors (Ignition relay circuit is short) • BCM • IPDM E/R

DTC CONFIRMATION PROCEDURE

1. PERFORM DTC CONFIRMATION PROCEDURE

1. Turn ignition switch ON, and wait for 2 seconds or more.
2. Check "Self-diagnosis result" with CONSULT.

Is DTC detected?

- YES >> Go to [PCS-66, "Diagnosis Procedure"](#).
 NO >> INSPECTION END

Diagnosis Procedure

INFOID:000000007161376

1. CHECK IPDM E/R SELF-DIAGNOSTIC RESULT

1. Turn ignition switch ON.
2. Erase the DTC of IPDM E/R.
3. Turn ignition switch OFF.
4. Turn ignition switch ON and check the DTC again.

Is DTC detected?

- YES >> Repair or replace the malfunctioning part. Refer to [PCS-24, "DTC Index"](#).
 NO >> GO TO 2.

2. CHECK IGNITION RELAY (IPDM E/R) CONTROL SIGNAL

1. Turn ignition switch OFF.
2. Check voltage between IPDM E/R harness connector and ground.

(+)		(-)	Condition		Voltage (V) (Approx.)
IPDM E/R					
Connector	Terminal	Ground	Ignition switch	OFF or ACC	6 - 16
E10	27				

Is the inspection result normal?

- YES >> Replace IPDM E/R.
 NO >> GO TO 3.

3. CHECK IGNITION RELAY (IPDM E/R) CONTROL SIGNAL CIRCUIT - 1

1. Turn ignition switch OFF.
2. Disconnect BCM and IPDM E/R connectors.
3. Check continuity between IPDM E/R harness connector and ground.

IPDM E/R		Ground	Continuity
Connector	Terminal		
E10	27		Not existed

Is the inspection result normal?

- YES >> GO TO 4.
 NO >> Repair or replace harness.

B26F2 IGNITION RELAY

< DTC/CIRCUIT DIAGNOSIS >

[POWER DISTRIBUTION SYSTEM]

4. CHECK IGNITION RELAY (IPDM E/R) CONTROL SIGNAL CIRCUIT - 2

1. Connect IPDM E/R connectors.
2. Check voltage between IPDM E/R harness connector and ground.

(+)		(-)	Condition		Voltage (V) (Approx.)
IPDM E/R					
Connector	Terminal	Ground	Ignition switch	OFF or ACC	6 - 16
E10	27				

Is the inspection result normal?

- YES >> Replace BCM. Refer to [BCS-82, "Removal and Installation"](#).
NO >> Replace IPDM E/R.

A
B
C
D
E
F
G
H
I
J
K
L

PCS

N
O
P

B26F6 BCM

DTC Logic

INFOID:000000007161377

DTC DETECTION LOGIC

NOTE:

- If DTC B26F6 is displayed with DTC U1000, first perform the trouble diagnosis for DTC U1000. Refer to [BCS-71, "DTC Logic"](#).
- If DTC B26F6 is displayed with DTC U1010, first perform the trouble diagnosis for DTC U1010. Refer to [BCS-72, "DTC Logic"](#).

DTC No.	Trouble diagnosis name	DTC detecting condition	Possible cause
B26F6	BCM	Ignition switch ON signal (CAN) (ON) is not transmitted from IPDM E/R, when BCM turns ignition relay ON [Transmit ignition switch ON signal (CAN) (ON)].	BCM

DTC CONFIRMATION PROCEDURE

1. PERFORM DTC CONFIRMATION PROCEDURE

1. Turn ignition switch ON, and wait for 0.5 seconds or more.
2. Check "Self-diagnosis result" of BCM with CONSULT.

Is DTC detected?

- YES >> Go to [PCS-68, "Diagnosis Procedure"](#).
 NO >> INSPECTION END

Diagnosis Procedure

INFOID:000000007161378

1. INSPECTION START

1. Turn ignition switch ON.
2. Select "Self-diagnosis result" of BCM with CONSULT.
3. Touch "ERASE".
4. Perform DTC Confirmation Procedure.
See [PCS-68, "DTC Logic"](#).

Is DTC detected?

- YES >> Replace BCM. Refer to [BCS-82, "Removal and Installation"](#)
 NO >> INSPECTION END

PUSH-BUTTON IGNITION SWITCH

< DTC/CIRCUIT DIAGNOSIS >

[POWER DISTRIBUTION SYSTEM]

PUSH-BUTTON IGNITION SWITCH

Component Function Check

INFOID:000000007161379

1.CHECK FUNCTION

1. Select "PUSH SW" in "Data Monitor" mode with CONSULT.
2. Check the push-button ignition switch signal under the following conditions.

Test item	Condition	Status
PUSH SW	Push-button ignition switch is pressed	ON
	Push-button ignition switch is not pressed	OFF

Is the indication normal?

- YES >> INSPECTION END.
NO >> Go to [PCS-69, "Diagnosis Procedure"](#).

Diagnosis Procedure

INFOID:000000007161380

1.CHECK PUSH-BUTTON IGNITION SWITCH OUTPUT SIGNAL 1

1. Turn ignition switch OFF.
2. Disconnect push-button ignition switch connector and IPDM E/R connector.
3. Check voltage between push-button ignition switch harness connector and ground.

(+)		(-)	Voltage (V) (Approx.)
Connector	Terminal		
M101	4	Ground	9 -16

Is the inspection result normal?

- YES >> GO TO 3.
NO >> GO TO 2.

2.CHECK PUSH-BUTTON IGNITION SWITCH CIRCUIT 1

1. Disconnect BCM connector.
2. Check continuity between BCM harness connector and push-button ignition switch harness connector.

BCM		Push-button ignition switch		Continuity
Connector	Terminal	Connector	Terminal	
M124	76	M101	4	Existed

3. Check continuity between BCM harness connector and ground.

BCM		Ground	Continuity
Connector	Terminal		
M124	76		Not existed

Is the inspection result normal?

- YES >> Replace BCM. Refer to [BCS-82, "Removal and Installation"](#).
NO >> Repair or replace harness.

3.CHECK PUSH-BUTTON IGNITION SWITCH OUTPUT SIGNAL 2

Check voltage between IPDM E/R harness connector and ground.

A
B
C
D
E
F
G
H
I
J
K
L
N
O
P

PCS

PUSH-BUTTON IGNITION SWITCH

< DTC/CIRCUIT DIAGNOSIS >

[POWER DISTRIBUTION SYSTEM]

(+)		(-)	Voltage (V) (Approx.)
IPDM E/R			
Connector	Terminal	Ground	9 - 16
E10	28		

Is the inspection result normal?

YES >> GO TO 5.

NO >> GO TO 4.

4.CHECK PUSH-BUTTON IGNITION SWITCH CIRCUIT 2

1. Disconnect BCM connector.
2. Check continuity between IPDM E/R harness connector and push-button ignition switch harness connector.

IPDM E/R		Push-button ignition switch		Continuity
Connector	Terminal	Connector	Terminal	
E10	28	M101	4	Existed

3. Check continuity between IPDM E/R harness connector and ground.

IPDM E/R		Ground	Continuity
Connector	Terminal		
E10	28		Not existed

Is the inspection result normal?

YES >> Replace IPDM E/R.

NO >> Repair or replace harness.

5.CHECK PUSH-BUTTON IGNITION SWITCH GROUND CIRCUIT

Check continuity between push-button ignition switch harness connector and ground.

Push-button ignition switch		Ground	Continuity
Connector	Terminal		
M101	1		Existed

Is the inspection result normal?

YES >> GO TO 6.

NO >> Repair or replace harness.

6.CHECK PUSH-BUTTON IGNITION SWITCH

Refer to [PCS-70, "Component Inspection"](#).

Is the inspection result normal?

YES >> GO TO 7.

NO >> Replace push-button ignition switch.

7.CHECK INTERMITTENT INCIDENT

Refer to [GI-42, "Intermittent Incident"](#).

>> INSPECTION END

Component Inspection

INFOID:000000007161381

1.CHECK PUSH-BUTTON IGNITION SWITCH

1. Turn ignition switch OFF.
2. Disconnect push-button ignition switch connector.
3. Check continuity between push-button ignition switch terminals.

PUSH-BUTTON IGNITION SWITCH

< DTC/CIRCUIT DIAGNOSIS >

[POWER DISTRIBUTION SYSTEM]

Push-button ignition switch		Condition	Continuity
Terminal			
4	1	Pressed	Existed
		Not pressed	Not existed

Is the inspection result normal?

YES >> INSPECTION END

NO >> Replace push-button ignition switch.

A
B
C
D
E
F
G
H
I
J
K
L
N
O
P

PCS

PUSH-BUTTON IGNITION SWITCH POSITION INDICATOR

< DTC/CIRCUIT DIAGNOSIS >

[POWER DISTRIBUTION SYSTEM]

PUSH-BUTTON IGNITION SWITCH POSITION INDICATOR

Description

INFOID:000000007050680

Push-button ignition switch changes the power supply position.
BCM maintains the power supply position status.
BCM changes the power supply position with the operation of the push-button ignition switch.

Component Function Check

INFOID:000000007050681

1.CHECK FUNCTION

Check push-button ignition switch ("LOCK INDICATOR", "ACC INDICATOR" and "IGNITION ON IND") in Active Test of BCM with CONSULT.

Test item		Description	
LOCK INDICATOR	ON	Position indicator	Illuminates
ACC INDICATOR IGNITION ON IND	OFF		Does not illuminate

Is the inspection result normal?

- YES >> INSPECTION END.
NO >> Refer to [PCS-72, "Diagnosis Procedure"](#).

Diagnosis Procedure

INFOID:000000007050682

1.CHECK PUSH-BUTTON IGNITION SWITCH INPUT SIGNAL

- Turn ignition switch OFF.
- Disconnect push-button ignition switch connector.
- Check voltage between push-button ignition switch harness connector and ground.

(+)		(-)	Voltage (V) (Approx.)
Push-button ignition switch			
Connector	Terminal	Ground	Battery voltage
M101	8		

Is the inspection normal?

- YES >> GO TO 2.
NO-1 >> Check 10 A fuse [No.10, located in fuse block (J/B)].
NO-2 >> Check harness for open or short between push-button ignition switch and fuse.

2.CHECK BCM INPUT

- Connect push-button ignition switch connector.
- Disconnect BCM connector.
- Check voltage between BCM connector and ground.

(+)		(-)	Voltage (V) (Approx.)
BCM			
Connector	Terminal	Ground	Battery voltage
M124	73		
	91		
	109		

Is the inspection normal?

- YES >> Replace BCM. Refer to [BCS-82, "Removal and Installation"](#).
NO >> GO TO 3.

3.CHECK PUSH-BUTTON IGNITION SWITCH CIRCUIT

- Disconnect push-button ignition switch connector.

PUSH-BUTTON IGNITION SWITCH POSITION INDICATOR

< DTC/CIRCUIT DIAGNOSIS >

[POWER DISTRIBUTION SYSTEM]

2. Check continuity between BCM harness connector and push-button ignition switch harness connector.

Indicator	BCM		Push-button ignition switch		Continuity
	Connector	Terminal	Connector	Terminal	
LOCK	M124	91	M101	5	Existed
ACC		109		6	
ON		73		7	

3. Check continuity between BCM harness connector and ground.

Indicator	BCM		Ground	Continuity
	Connector	Terminal		
LOCK	M124	91	Ground	Not existed
ACC		109		
ON		73		

Is the inspection normal?

- YES >> Replace push-button ignition switch.
- NO >> Repair or replace harness.

A
B
C
D
E
F
G
H
I
J
K
L
N
O
P

PCS

PUSH-BUTTON IGNITION SWITCH DOES NOT OPERATE

< SYMPTOM DIAGNOSIS >

[POWER DISTRIBUTION SYSTEM]

SYMPTOM DIAGNOSIS

PUSH-BUTTON IGNITION SWITCH DOES NOT OPERATE

Description

INFOID:000000007050683

Check that vehicle is under the condition shown in “Conditions of vehicle” before starting diagnosis, and check each symptom.

NOTE:

The engine start function, door lock function, power distribution system, and NATS-IVIS/NVIS in the Intelligent Key system are closely related to each other regarding control. The vehicle security function can operate only when the door lock and power distribution system are operating normally.

Conditions of Vehicle (Operating Conditions)

- “ENGINE START BY I-KEY” in “WORK SUPPORT” is ON when setting on CONSULT.
- One or more of Intelligent Keys with registered Intelligent Key ID is in the vehicle.

Diagnosis Procedure

INFOID:000000007050684

1.PERFORM WORK SUPPORT

Perform “INSIDE ANT DIAGNOSIS” on Work Support of “INTELLIGENT KEY”.

Refer to [DLK-90, "INTELLIGENT KEY : CONSULT Function \(BCM - INTELLIGENT KEY\)"](#).

>> GO TO 2.

2.PERFORM SELF-DIAGNOSIS RESULT

Perform Self-Diagnosis Result of “BCM”.

Is DTC detected?

YES >> Refer to [BCS-58, "DTC Index"](#).

NO >> GO TO 3.

3.CHECK PUSH-BUTTON IGNITION SWITCH

Check push-button ignition switch.

Refer to [PCS-69, "Component Function Check"](#).

Is the operation normal?

YES >> GO TO 4.

NO >> Repair or replace malfunctioning parts.

4.CONFIRM THE OPERATION

Confirm the operation again.

Is the inspection normal?

YES >> Check intermittent incident. Refer to [GI-42, "Intermittent Incident"](#).

NO >> GO TO 1.

PUSH-BUTTON IGNITION SWITCH POSITION INDICATOR DOES NOT ILLUMINATE

< SYMPTOM DIAGNOSIS >

[POWER DISTRIBUTION SYSTEM]

PUSH-BUTTON IGNITION SWITCH POSITION INDICATOR DOES NOT ILLUMINATE

Description

INFOID:000000007050685

- Before performing the diagnosis in the following table, check “Work Flow”. Refer to [PCS-52, "Work Flow"](#).
- Check that vehicle is under the condition shown in “Conditions of vehicle” before starting diagnosis, and check each symptom.

Conditions of Vehicle (Operating Conditions)

- “ENGINE START BY I-KEY” in “WORK SUPPORT” is ON when setting on CONSULT.
- One or more of Intelligent Keys with registered Intelligent Key ID is in the vehicle.

Diagnosis Procedure

INFOID:000000007050686

1. CHECK PUSH-BUTTON IGNITION SWITCH INDICATOR

Check push-button ignition switch indicator.

Refer to [PCS-72, "Component Function Check"](#).

Is the inspection result normal?

YES >> GO TO 2.

NO >> Repair or replace the malfunctioning parts.

2. CONFIRM THE OPERATION

Confirm the operation again.

Is the result normal?

YES >> Check intermittent incident. Refer to [GI-42, "Intermittent Incident"](#).

NO >> GO TO 1.

A
B
C
D
E
F
G
H
I
J
K
L

PCS

N
O
P