

SECTION MA
MAINTENANCE

A
B
C
D
E
F
G
H
I
J
K
L
M
N
O

CONTENTS

PREPARATION	3	AIR CLEANER FILTER : Removal and Installation	16
PREPARATION	3	ENGINE OIL	17
Special Service Tool	3	ENGINE OIL : Draining	17
Commercial Service Tool	3	ENGINE OIL : Refilling	17
PERIODIC MAINTENANCE	4	OIL FILTER	17
GENERAL MAINTENANCE	4	OIL FILTER : Removal and Installation	18
Explanation of General Maintenance	4	OIL FILTER : Inspection	18
PERIODIC MAINTENANCE	6	SPARK PLUG	18
Introduction of Periodic Maintenance	6	SPARK PLUG : Removal and Installation	19
Schedule 1	6	SPARK PLUG : Inspection	19
Schedule 2	8	POSITIVE CRANKCASE VENTILATION SYSTEM...	19
RECOMMENDED FLUIDS AND LUBRICANTS	10	POSITIVE CRANKCASE VENTILATION SYSTEM : Work Procedure	20
Fluids and Lubricants	10	EVAP VAPOR LINES	20
Engine Oil Recommendation	10	EVAP VAPOR LINES : Inspection	20
Anti-Freeze Coolant Mixture Ratio	10	CHASSIS MAINTENANCE	21
ENGINE MAINTENANCE	12	EXHAUST SYSTEM	21
DRIVE BELT	12	EXHAUST SYSTEM : Inspection	21
DRIVE BELT : Exploded View	12	CVT FLUID	21
DRIVE BELT : Checking	12	CVT FLUID : Inspection	21
DRIVE BELT : Tension Adjustment	12	WHEELS	22
ENGINE COOLANT	12	WHEELS : Wheel Balance Adjustment	22
ENGINE COOLANT : Draining	12	WHEELS : Tire Rotation	24
ENGINE COOLANT : Refilling	13	BRAKE FLUID LEVEL AND LEAKS	24
ENGINE COOLANT : Flushing	15	BRAKE FLUID LEVEL AND LEAKS : Inspection	25
RADIATOR CAP	15	BRAKE LINES AND CABLES	25
RADIATOR CAP : Inspection	15	BRAKE LINES AND CABLES : Inspection	25
RADIATOR	16	BRAKE FLUID	25
RADIATOR : Inspection	16	BRAKE FLUID : Changing	25
FUEL LINES	16	DISC BRAKE	25
FUEL LINES : Inspection	16	DISC BRAKE : Inspection	25
AIR CLEANER FILTER	16		

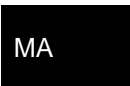

DISC BRAKE : Front Disc Brake	26	SEAT BELT, BUCKLES, RETRACTORS, AN- CHORS AND ADJUSTERS : Inspection	29
DISC BRAKE : Rear Disc Brake	26		
STEERING GEAR AND LINKAGE	26	SERVICE DATA AND SPECIFICATIONS	
STEERING GEAR AND LINKAGE : Inspection	26	(SDS)	30
POWER STEERING FLUID AND LINES	27	SERVICE DATA AND SPECIFICATIONS	
POWER STEERING FLUID AND LINES : Inspec- tion	27	(SDS)	30
AXLE AND SUSPENSION PARTS	27	DRIVE BELT	30
AXLE AND SUSPENSION PARTS : Inspection	27	DRIVE BELT : Drive Belt	30
DRIVE SHAFT	27	ENGINE COOLANT	30
DRIVE SHAFT : Inspection	28	ENGINE COOLANT : Periodical Maintenance Specification	30
BODY MAINTENANCE	29	ENGINE OIL	30
LOCKS, HINGES AND HOOD LATCH	29	ENGINE OIL : Periodical Maintenance Specification	30
LOCKS, HINGES AND HOOD LATCH : Lubricat- ing	29	SPARK PLUG	30
SEAT BELT, BUCKLES, RETRACTORS, AN- CHORS AND ADJUSTERS	29	SPARK PLUG : Spark Plug	30
		ROAD WHEEL	30
		ROAD WHEEL : Road Wheel	30

PREPARATION

< PREPARATION >

PREPARATION

PREPARATION

Special Service Tool

INFOID:000000007494684

The actual shapes of Kent-Moore tools may differ from those of special service tools illustrated here.

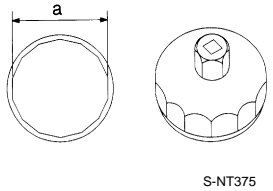
Tool number (Kent-Moore No.) Tool name	Description
KV10115801 (J-38956) Oil filter wrench 	Removing and installing oil filter a: 64.3 mm (2.531 in)

Commercial Service Tool

INFOID:000000007494685

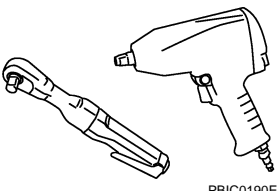
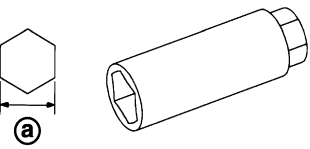
Tool name (Kent-Moore No.)	Description
Power tool (—) 	Loosening nuts and bolts
Spark plug wrench (—) 	Removing and installing spark plug a : 14 mm (0.55 in)

A
B
C
D
E
F
G
H
I
J
K
L
M
N
O

MA

GENERAL MAINTENANCE

< PERIODIC MAINTENANCE >

PERIODIC MAINTENANCE

GENERAL MAINTENANCE

Explanation of General Maintenance

INFOID:000000007494686

General maintenance includes those items which should be checked during the normal day-to-day operation of the vehicle. They are essential if the vehicle is to continue operating properly. The owners can perform checks and inspections themselves or have their **NISSAN** dealers do them.

OUTSIDE THE VEHICLE

The maintenance items listed here should be performed from time to time, unless otherwise specified.

Item		Reference page
Tires	Check the pressure with a gauge often and always prior to long distance trips. Adjust the pressure in all tires, including the spare, to the pressure specified. Check carefully for damage, cuts or excessive wear.	WT-48
Wheel nuts	When checking the tires, make sure no nuts are missing, and check for any loose nuts. Tighten if necessary.	—
Tire rotation	Tires should be rotated every 7,500 miles (12,000 km).	MA-24
Tire Pressure Monitoring System (TPMS) transmitter components	Replace the TPMS transmitter grommet seal, valve core and cap when the tires are replaced due to wear or age.	WT-45
Wheel alignment and balance	If the vehicle should pull to either side while driving on a straight and level road, or if you detect uneven or abnormal tire wear, there may be a need for wheel alignment. If the steering wheel or seat vibrates at normal highway speeds, wheel balancing may be needed. For additional information regarding tires, refer to "Important Tire Safety Information" (US) or "Tire Safety Information" (Canada) in the NISSAN Warranty Information Booklet.	FSU-6 RSU-6 MA-22
Windshield	Clean the windshield on a regular basis. Check the windshield at least every six months for cracks or other damage. Repair as necessary.	—
Windshield wiper blades	Check for cracks or wear if they do not wipe properly.	—
Doors and engine hood	Check that all doors and the engine hood operate smoothly as well as the back door, trunk lid and glass hatch. Also make sure that all latches lock securely. Lubricate if necessary. Make sure that the secondary latch keeps the hood from opening when the primary latch is released. When driving in areas using road salt or other corrosive materials, check lubrication frequently.	MA-29
Lamps	Make sure that the headlamps, stop lamps, tail lamps, turn signal lamps, and other lamps are all operating properly and installed securely. Also check headlamp aim. Clean the headlamps on a regular basis.	—

INSIDE THE VEHICLE

The maintenance items listed here should be checked on a regular basis, such as when performing periodic maintenance, cleaning the vehicle, etc.

Item		Reference page
Warning lamps and chimes	Make sure that all warning lamps and chimes are operating properly.	—
Windshield wiper and washer	Check that the wipers and washer operate properly and that the wipers do not streak.	—
Windshield defroster	Check that the air comes out of the defroster outlets properly and in sufficient quantity when operating the heater or air conditioner.	—
Steering wheel	Check that it has the specified play. Check for changes in the steering condition, such as excessive play, hard steering or strange noises. Free play: Less than 35 mm (1.38 in)	—
Seats	Check seat position controls such as seat adjusters, seatback recliner, etc. to make sure they operate smoothly and that all latches lock securely in every position. Check that the head restraints move up and down smoothly and that the locks (if equipped) hold securely in all latched positions. Check that the latches lock securely for folding-down rear seatbacks.	—

GENERAL MAINTENANCE

< PERIODIC MAINTENANCE >

Item		Reference page	
Seat belts	Check that all parts of the seat belt system (e.g. buckles, anchors, adjusters and retractors) operate properly and smoothly, and are installed securely. Check the belt webbing for cuts, fraying, wear or damage.	MA-29	A
Accelerator pedal	Check the pedal for smooth operation and make sure the pedal does not catch or require uneven effort. Keep the floor mats away from the pedal.	—	B
Brakes	Check that the brake does not pull the vehicle to one side when applied.	—	C
Brake pedal and booster	Check the pedal for smooth operation and make sure it has the proper distance under it when depressed fully. Check the brake booster function. Be sure to keep the floor mats away from the pedal.	BR-7 BR-13	D
Parking brake	Check that the pedal has the proper travel and make sure that the vehicle is held securely on a fairly steep hill when only the parking brake is applied.	PB-3	E
CVT P (Park) position mechanism	On a fairly steep hill check that the vehicle is held securely with the selector lever in the P (Park) position without applying any brakes.	—	

UNDER THE HOOD AND VEHICLE

The maintenance items listed here should be checked periodically (e.g. each time you check the engine oil or refuel).

Item		Reference page	
Windshield washer fluid	Check that there is adequate fluid in the tank.	—	F
Engine coolant level	Check the coolant level when the engine is cold.	CO-8	G
Radiator and hoses	Check the front of the radiator and clean off any dirt, insects, leaves, etc., that may have accumulated. Make sure the hoses have no cracks, deformation, deterioration or loose connections.	MA-16	H
Brake fluid level	Make sure that the brake fluid level is between the “MAX” and “MIN” lines on the reservoir.	MA-25	I
Battery	Check the fluid level in each cell. It should be between the “MAX” and “MIN” lines. Vehicles operated in high temperatures or under severe conditions require frequent checks of the battery fluid level.	PG-119	J
Engine drive belt	Make sure that no belt is frayed, worn, cracked or oily.	MA-12	K
Engine oil level	Check the level on the oil level gauge after parking the vehicle on a level spot and turning off the engine.	LU-7	L
Power steering fluid level and lines	Check the level on the dipstick with the engine off. Check the lines for improper attachment, leaks, cracks, etc.	MA-27	M
Exhaust system	Make sure there are no loose supports, cracks or holes. If the sound of the exhaust seems unusual or there is a smell of exhaust fumes, immediately locate the trouble and correct it.	MA-21	N
Underbody	The underbody is frequently exposed to corrosive substances such as those used on icy roads or to control dust. It is very important to remove these substances, otherwise rust will form on the floor pan, frame, fuel lines and around the exhaust system. At the end of winter, the underbody should be thoroughly flushed with plain water, being careful to clean those areas where mud and dirt can easily accumulate.	—	O
Fluid leaks	Check under the vehicle for fuel, oil, water or other fluid leaks after the vehicle has been parked for a while. Water dripping from the air conditioner after use is normal. If you should notice any leaks or gasoline fumes are evident, check for the cause and correct it immediately.	—	

PERIODIC MAINTENANCE

< PERIODIC MAINTENANCE >

PERIODIC MAINTENANCE

Introduction of Periodic Maintenance

INFOID:000000007494687

Two different maintenance schedules are provided, and should be used, depending upon the conditions in which the vehicle is mainly operated. **After 60,000 miles (96,000 km) or 48 months, continue the periodic maintenance at the same mileage/time intervals.**

Schedule 1	Follow Periodic Maintenance Schedule 1 if the driving habits frequently include one or more of the following driving conditions: <ul style="list-style-type: none"> • Repeated short trips of less than 5 miles (8 km). • Repeated short trips of less than 10 miles (16 km) with outside temperatures remaining below freezing. • Operating in hot weather in stop-and-go “rush hour” traffic. • Extensive idling and/or low speed driving for long distances, such as police, taxi or door-to-door delivery use. • Driving in dusty conditions. • Driving on rough, muddy, or salt spread roads. • Towing a trailer, using a camper or a car-top carrier. 	Emission Control System Maintenance	MA-6
		Chassis and Body Maintenance	
Schedule 2	Follow Periodic Maintenance Schedule 2 if none of driving conditions shown in Schedule 1 apply to the driving habits.	Emission Control System Maintenance	MA-8
		Chassis and Body Maintenance	

Schedule 1

INFOID:000000007494688

EMISSION CONTROL SYSTEM

Abbreviations: R = Replace. I = Inspect. Correct or replace if necessary. []: At the mileage intervals only

MAINTENANCE OPERATION		MAINTENANCE INTERVAL								Reference Section - Page or - Content Title	
Perform at number of miles, kilometers or months, whichever comes first.	Miles x 1,000 (km x 1,000) Months	3.75 (6)	7.50 (12)	11.25 (18)	15 (24)	18.75 (30)	22.5 (36)	26.25 (42)	30 (48)		
Drive belt	NOTE (1)									[R]	MA-12
Air cleaner filter	NOTE (2)									[R]	MA-16
EVAP vapor lines										I*	MA-20
Fuel lines										I*	MA-16
Fuel filter	NOTE (3)										—
Engine coolant*	NOTE (4)										MA-12
Engine oil		R	R	R	R	R	R	R	R	MA-17	
Engine oil filter (Use genuine NISSAN engine oil filter or equivalent.)		R	R	R	R	R	R	R	R	MA-18	
Spark plugs (Iridium-tipped type)		Replace every 105,000 miles (168,000 km).								MA-19	
Intake & exhaust valve clearance*	NOTE (5)										EM-18

MAINTENANCE OPERATION		MAINTENANCE INTERVAL								Reference Section - Page or - Content Title	
Perform at number of miles, kilometers or months, whichever comes first.	Miles x 1,000 (km x 1,000) Months	33.75 (54)	37.5 (60)	41.25 (66)	45 (72)	48.75 (78)	52.5 (84)	56.25 (90)	60 (96)		
Drive belt	NOTE (1)									I*	MA-12
Air cleaner filter	NOTE (2)									[R]	MA-16
EVAP vapor lines										I*	MA-20
Fuel lines										I*	MA-16

PERIODIC MAINTENANCE

< PERIODIC MAINTENANCE >

MAINTENANCE OPERATION		MAINTENANCE INTERVAL								Reference Section - Page or - Content Title
Perform at number of miles, kilometers or months, whichever comes first.	Miles x 1,000 (km x 1,000) Months	33.75 (54) 27	37.5 (60) 30	41.25 (66) 33	45 (72) 36	48.75 (78) 39	52.5 (84) 42	56.25 (90) 45	60 (96) 48	
Fuel filter	NOTE (3)									—
Engine coolant*	NOTE (4)									MA-12
Engine oil		R	R	R	R	R	R	R	R	MA-17
Engine oil filter (Use genuine NISSAN engine oil filter or equivalent.)		R	R	R	R	R	R	R	R	MA-18
Spark plugs (Iridium-tipped type)		Replace every 105,000 miles (168,000 km).								MA-19
Intake & exhaust valve clearance*	NOTE (5)									EM-18

NOTE:

- (1) After 60,000 miles (96,000 km) or 48 months, inspect every 15,000 miles (24,000 km) or 12 months. Replace the drive belts if found damaged or if the auto belt tensioner reading reaches the maximum limit.
- (2) If operating mainly in dusty conditions, more frequent maintenance may be required.
- (3) Maintenance-free item. For service procedures, refer to FL section.
- (4) First replacement interval is 105,000 miles (168,000 km) or 84 months. After first replacement, replace every 75,000 miles (120,000 km) or 60 months. Use only Genuine NISSAN Long Life Antifreeze/Coolant (blue) or equivalent with proper mixture ratio of 50% anti-freeze and 50% demineralized or distilled water. Mixing any other type of coolant or the use of non-distilled water will reduce the life expectancy of the factory-fill coolant.
- (5) Periodic maintenance is not required. However, if valve noise increases, inspect valve clearance.

* Maintenance items and intervals with "*" are recommended by NISSAN for reliable vehicle operation. The owner need not perform such maintenance in order to maintain the emission warranty or manufacturer recall liability. Other maintenance items and intervals are required.

CHASSIS AND BODY

Abbreviations: R = Replace. I = Inspect. Correct or replace if necessary.

MAINTENANCE OPERATION		MAINTENANCE INTERVAL								Reference Section - Page or - Content Title
Perform at number of miles, kilometers or months, whichever comes first.	Miles x 1,000 (km x 1,000) Months	3.75 (6) 3	7.50 (12) 6	11.25 (18) 9	15 (24) 12	18.75 (30) 15	22.5 (36) 18	26.25 (42) 21	30 (48) 24	
Brake lines & cables					I				I	MA-25
Brake pads & rotors			I		I		I		I	MA-25
Brake fluid					R				R	MA-25
CVT fluid	NOTE (1)				I				I	MA-21
Steering gear & linkage, axle & suspension parts			I		I		I		I	MA-26 MA-27
Tire rotation	NOTE (2)									MA-4 WT-42
Drive shaft boots			I		I		I		I	MA-28
Exhaust system			I		I		I		I	MA-21
In-cabin microfilter					R				R	VTL-18

MAINTENANCE OPERATION		MAINTENANCE INTERVAL								Reference Section - Page or - Content Title
Perform at number of miles, kilometers or months, whichever comes first.	Miles x 1,000 (km x 1,000) Months	33.75 (54) 27	37.5 (60) 30	41.25 (66) 33	45 (72) 36	48.75 (78) 39	52.5 (84) 42	56.25 (90) 45	60 (96) 48	
Brake lines & cables					I				I	MA-25
Brake pads & rotors			I		I		I		I	MA-25
Brake fluid					R				R	MA-25

PERIODIC MAINTENANCE

< PERIODIC MAINTENANCE >

MAINTENANCE OPERATION		MAINTENANCE INTERVAL								Reference Section - Page or - Content Title
Perform at number of miles, kilometers or months, whichever comes first.	Miles x 1,000 (km x 1,000) Months	33.75 (54) 27	37.5 (60) 30	41.25 (66) 33	45 (72) 36	48.75 (78) 39	52.5 (84) 42	56.25 (90) 45	60 (96) 48	
CVT fluid	NOTE (1)				I				I	MA-21
Steering gear & linkage, axle & suspension parts			I		I		I		I	MA-26 MA-27
Tire rotation	NOTE (2)									MA-4 WT-42
Drive shaft boots			I		I		I		I	MA-28
Exhaust system			I		I		I		I	MA-21
In-cabin microfilter					R				R	VTL-18

NOTE:

(1) Use only Genuine NISSAN CVT fluid (NS-2). If towing a trailer, using a camper or a car-top carrier or driving on rough or muddy roads, inspect CVT fluid deterioration at NISSAN dealers every 100,000 km (60,000 miles), then change CVT fluid NS-2 if necessary. And if the inspection is not be performed, change (not just inspect) CVT fluid NS-2 every 100,000 km (60,000 miles). Using transmission fluid other than Genuine NISSAN CVT Fluid NS-2 will damage the CVT, which is not covered by the warranty.

(2) Refer to "Tire rotation" under the "General maintenance" heading earlier in this section.

Schedule 2

INFOID:000000007494689

EMISSION CONTROL SYSTEM

Abbreviations: R = Replace. I = Inspect. Correct or replace if necessary. []: At the mileage intervals only

MAINTENANCE OPERATION		MAINTENANCE INTERVAL								Reference Section - Page or - Content Title
Perform at number of miles, kilometers or months, whichever comes first.	Miles x 1,000 (km x 1,000) Months	7.5 (12) 6	15 (24) 12	22.5 (36) 18	30 (48) 24	37.5 (60) 30	45 (72) 36	52.5 (84) 42	60 (96) 48	
Drive belt	NOTE (1)								I*	MA-12
Air cleaner filter					[R]				[R]	MA-16
EVAP vapor lines					I*				I*	MA-20
Fuel lines					I*				I*	MA-16
Fuel filter	NOTE (2)									—
Engine coolant*	NOTE (3)									MA-12
Engine oil		R	R	R	R	R	R	R	R	MA-17
Engine oil filter (Use genuine NISSAN engine oil filter or equivalent.)		R	R	R	R	R	R	R	R	MA-18
Spark plugs (Iridium-tipped type)		Replace every 105,000 miles (168,000 km).								MA-19
Intake & exhaust valve clearance*	NOTE (4)									EM-18

NOTE:

(1) After 60,000 miles (96,000 km) or 48 months, inspect every 15,000 miles (24,000 km) or 12 months. Replace the drive belts if found damaged or if the auto belt tensioner reading reaches the maximum limit.

(2) Maintenance-free item. For service procedures, refer to FL section.

(3) First replacement interval is 105,000 miles (168,000 km) or 84 months. After first replacement, replace every 75,000 miles (120,000 km) or 60 months. Use only Genuine NISSAN Long Life Antifreeze/Coolant (blue) or equivalent with proper mixture ratio of 50% anti-freeze and 50% demineralized or distilled water. Mixing any other type of coolant or the use of non-distilled water will reduce the life expectancy of the factory-fill coolant.

(4) Periodic maintenance is not required. However, if valve noise increases, inspect valve clearance.

* Maintenance items and intervals with "*" are recommended by NISSAN for reliable vehicle operation. The owner need not perform such maintenance in order to maintain the emission warranty or manufacturer recall liability. Other maintenance items and intervals are required.

CHASSIS AND BODY

PERIODIC MAINTENANCE

< PERIODIC MAINTENANCE >

Abbreviations: R = Replace. I = Inspect. Correct or replace if necessary.

MAINTENANCE OPERATION		MAINTENANCE INTERVAL								Reference Section - Page or - Content Title
Perform at number of miles, kilometers or months, whichever comes first.	Miles x 1,000 (km x 1,000) Months	7.5 (12) 6	15 (24) 12	22.5 (36) 18	30 (48) 24	37.5 (60) 30	45 (72) 36	52.5 (84) 42	60 (96) 48	
Brake lines & cables			I		I		I		I	MA-25
Brake pads & rotors			I		I		I		I	MA-25
Brake fluid					R				R	MA-25
CVT fluid	NOTE (1)		I		I		I		I	MA-21
Steering gear & linkage, axle & sus- sension parts					I				I	MA-26 MA-27
Tire rotation	NOTE (2)									MA-4 WT-42
Drive shaft boots			I		I		I		I	MA-28
Exhaust system					I				I	MA-21
In-cabin microfilter			R		R		R		R	VTL-18

NOTE:

(1) Using transmission fluid other than Genuine NISSAN CVT Fluid NS-2 will damage the CVT, which is not covered by the NISSAN new vehicle limited warranty.

(2) Refer to "Tire rotation" under the "General maintenance" heading earlier in this section.

A
B
C
D
E
F
G
H
I
J
K
L
M
N
O

MA

RECOMMENDED FLUIDS AND LUBRICANTS

< PERIODIC MAINTENANCE >

RECOMMENDED FLUIDS AND LUBRICANTS

Fluids and Lubricants

INFOID:000000007494690

		Capacity (Approximate)			Recommended Fluids/Lubricants
		US measure	Imp measure	Liter	
Engine oil Drain and refill	With oil filter change	4-7/8 qt	4 qt	4.6	<ul style="list-style-type: none"> • Engine oil with API Certification Mark • Viscosity SAE 5W-30^{*1,*2}
	Without oil filter change	4-1/2 qt	3-3/4 qt	4.3	
Dry engine (Overhaul)		5-5/8 qt	4-5/8 qt	5.3	
Cooling system	With reservoir tank	12 qt	10 qt	11.3	Pre-diluted Genuine NISSAN Long Life Antifreeze/ Coolant (blue) or equivalent
	Reservoir tank	6/8 qt	5/8 qt	0.75	
CVT fluid		9 qt ^{*6}	10-6/8 qt ^{*6}	10.2 ^{*6}	Genuine NISSAN CVT fluid NS-2 ^{*3}
Power steering fluid (PSF)		1-1/8 qt	7/8 qt	1.0	Genuine NISSAN E-PSF or equivalent ^{*4}
Brake fluid		—	—	—	Genuine NISSAN Super Heavy Duty Brake Fluid ^{*5} or equivalent DOT 3 (US FMVSS No.116)
Multi-purpose grease		—	—	—	NLGI No. 2 (Lithium soap base)
Windshield washer fluid		—	—	—	Genuine NISSAN Windshield Washer Concentrate Cleaner & Antifreeze or equivalent
Fuel recommendation		—	—	—	Refer to GI-33, "Fuel" .

*1: For additional information, see "Engine Oil Recommendation".

*2: NISSAN recommends Genuine NISSAN Ester oil available an NISSAN dealer.

*3: Using only Genuine NISSAN CVT fluid NS-2. Using transmission fluid other than Genuine NISSAN CVT fluid NS-2 will damage the CVT, which is not covered by the NISSAN new vehicle warranty.

*4: Use of a power steering fluid other than Genuine NISSAN E-PSF will prevent the power steering system from operating properly.

*5: Available in mainland U.S.A. through an NISSAN dealer.

*6: The fluid capacity is the reference value.

Engine Oil Recommendation

INFOID:000000007494691

NISSAN recommends the use of an energy conserving oil in order to improve fuel economy. Select only engine oils that meet the American Petroleum Institute (API) certification and International Lubricant Standardization and Approval Committee (ILSAC) certification and SAE viscosity standard. These oils have the API certification mark on the front of the container. Oils which do not have the specified quality label should not be used as they could cause engine damage.

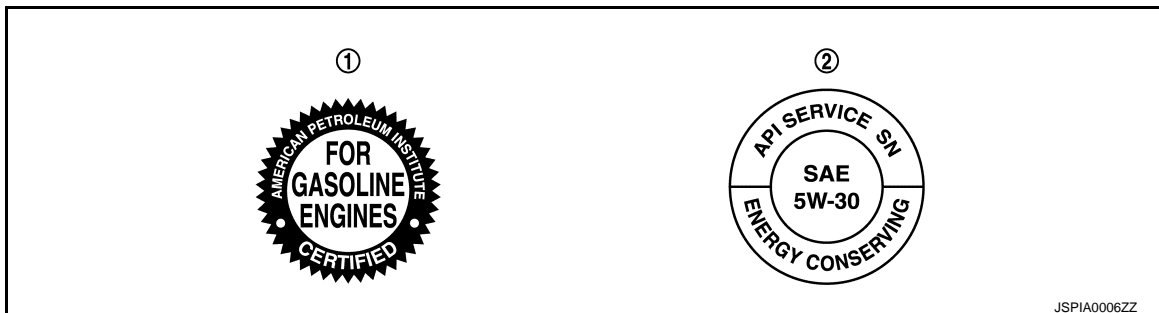

JSP1A0006ZZ

1. API certification mark

2. API service symbol

Anti-Freeze Coolant Mixture Ratio

INFOID:000000007494692

The engine cooling system is filled at the factory with a pre-diluted mixture of 50% Genuine NISSAN Long Life Antifreeze/Coolant (blue) and 50% water to provide year-round anti-freeze and coolant protection. The anti-freeze solution contains rust and corrosion inhibitors. Additional engine cooling system additives are not necessary.

RECOMMENDED FLUIDS AND LUBRICANTS

< PERIODIC MAINTENANCE >

WARNING:

- Never remove the radiator or coolant reservoir cap when the engine is hot. Wait until the engine and radiator cool down. Serious burns could be caused by high pressure fluid escaping from the radiator. See precautions in “If your vehicle overheats” found in the “In case of emergency” section of this manual.
- The radiator is equipped with a pressure type radiator cap. To prevent engine damage, use only a genuine NISSAN radiator cap.

CAUTION:

- When adding or replacing coolant, be sure to use only Genuine NISSAN Long Life Antifreeze/Coolant (blue) or equivalent. Genuine NISSAN Long Life Antifreeze/Coolant (blue) is pre-diluted to provide antifreeze protection to -34°F (-37°C). If additional freeze protection is needed due to weather where you operate your vehicle, add Genuine NISSAN Long Life Antifreeze/Coolant (blue) concentrate following the directions on the container. If an equivalent coolant other than Genuine NISSAN Long Life Antifreeze/Coolant (blue) is used, follow the coolant manufacturer's instructions to maintain minimum antifreeze protection to -34°F (-37°C). The use of other types of coolant solutions other than Genuine NISSAN Long Life Antifreeze/Coolant (blue) or equivalent may damage the engine cooling system.
- The life expectancy of the factory-fill coolant is 105,000 miles (168,000 km) or 7 years. Mixing any other type of coolant other than Genuine NISSAN Long Life Antifreeze/Coolant (blue), including Genuine NISSAN Long Life Antifreeze/Coolant (green), or the use of non-distilled water will reduce the life expectancy of the factory-fill coolant. Refer to the Nissan Service and Maintenance Guide for more details.

A
B
C
D
E
F
G
H
I
J
K
L
M
N
O

MA

ENGINE MAINTENANCE

< PERIODIC MAINTENANCE >

ENGINE MAINTENANCE

DRIVE BELT

DRIVE BELT : Exploded View

INFOID:000000007494693

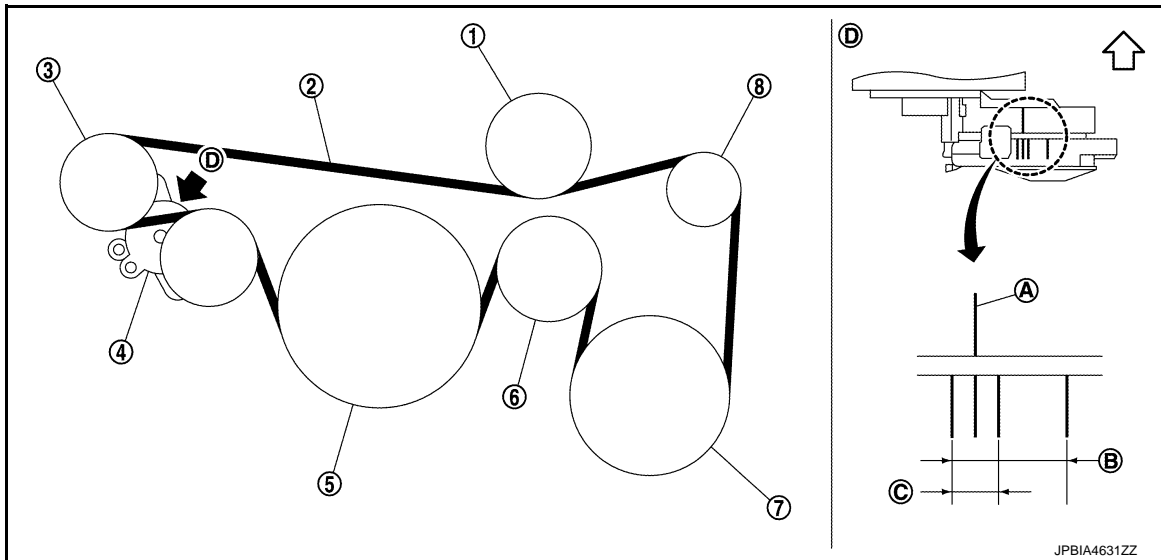

- | | | |
|------------------------------|-----------------------|-------------------------------------------|
| 1. Idler pulley | 2. Drive belt | 3. Idler pulley |
| 4. Drive belt auto-tensioner | 5. Crankshaft pulley | 6. Idler pulley |
| 7. A/C compressor | 8. Alternator | |
| A. Indicator | B. Possible use range | C. Range when new drive belt is installed |
| D. View D | | |
- ↩ : Engine front

DRIVE BELT : Checking

INFOID:000000007494694

WARNING:

Be sure to perform the this step when engine is stopped.

- Check that the indicator (A) of drive belt auto-tensioner is within the possible use range (B).

NOTE:

- Check the drive belt auto-tensioner indication when the engine is cold.
- When new drive belt is installed, the indicator should be within the range (C) in the figure.
- Visually check entire drive belt for wear, damage or cracks.
- If the indicator is out of the possible use range or belt is damaged, replace drive belt.

DRIVE BELT : Tension Adjustment

INFOID:000000007494695

Refer to [MA-30. "DRIVE BELT : Drive Belt"](#).

ENGINE COOLANT

ENGINE COOLANT : Draining

INFOID:000000007881968

WARNING:

- To avoid being scalded, never change engine coolant when the engine is hot.
- Wrap a thick cloth around radiator cap and carefully remove radiator cap. First, turn radiator cap a quarter of a turn to release built-up pressure. Then turn radiator cap all the way.

1. Remove engine under cover.

ENGINE MAINTENANCE

< PERIODIC MAINTENANCE >

2. Open radiator drain plug (1) at the bottom of radiator, and then remove radiator cap.

← : Vehicle front

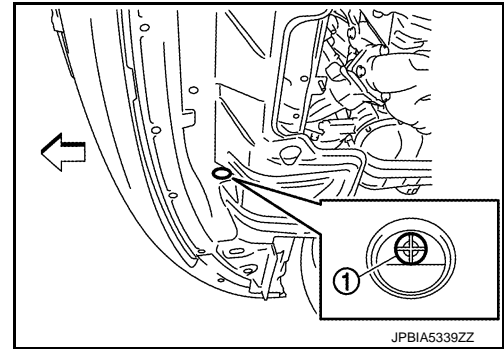

When draining all of engine coolant in the system, open water drain plugs on cylinder block. Refer to [EM-63, "Setting"](#).

3. Remove reservoir tank if necessary, and drain engine coolant and clean reservoir tank before installing.
4. Check drained engine coolant for contaminants such as rust, corrosion or discoloration. If contaminated, flush the engine cooling system. Refer to [CO-10, "Flushing"](#).

ENGINE COOLANT : Refilling

INFOID:000000007825214

CAUTION:

- Do not reuse O-rings.
- Do not put additive such as waterleak preventive, since it may cause cooling waterway clogging.
- When refilling use Genuine NISSAN Long Life Antifreeze/Coolant (blue) or equivalent in its quality mixed with water (distilled or demineralized). Refer to [MA-10, "Fluids and Lubricants"](#).

1. Install reservoir tank if removed and radiator drain plug.

CAUTION:

Be sure to clean drain plug and install with new O-ring.

Tightening torque : Refer to [CO-13, "Exploded View"](#).

If water drain plugs on cylinder block are removed, close and tighten them. Refer to [EM-105, "Disassembly and Assembly"](#).

2. Check that each hose clamp has been firmly tightened.
3. Remove air duct assembly and air cleaner cases (upper and lower) assembly. Refer to [EM-26, "Exploded View"](#).
4. Remove air bleeder plug (1) of heater pipe.

← : Vehicle front

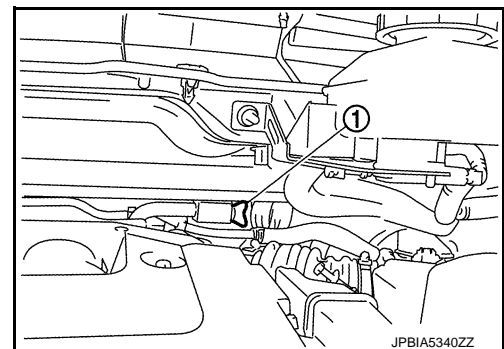

5. Fill radiator, and reservoir tank if removed, to specified level.

CAUTION:

A
B
C
D
E
F
G
H
I
J
K
L
M
N
O

MA

ENGINE MAINTENANCE

< PERIODIC MAINTENANCE >

Never adhere the engine coolant to electronic equipments. (alternator etc.)

- Pour engine coolant through engine coolant filler neck slowly of less than 2 l (2-1/8 US qt, 1-3/4 Imp qt) a minute to allow air in system to escape.
- When coolant comes out from the air bleeder plug of heater pipe, tighten the bleeder plug.

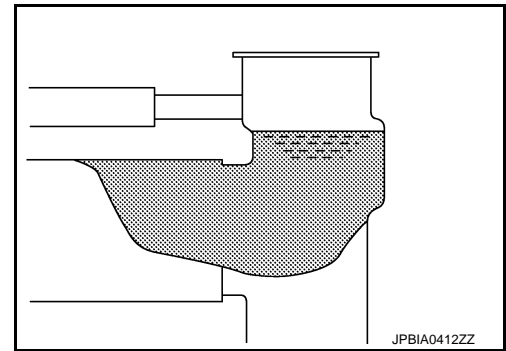

Engine coolant capacity
(With reservoir tank at "MAX" level)

: Refer to [CO-28, "Periodical Maintenance Specification"](#).

Reservoir tank engine coolant capacity
(At "MAX" level)

: Refer to [CO-28, "Periodical Maintenance Specification"](#).

A : MAX

B : MIN

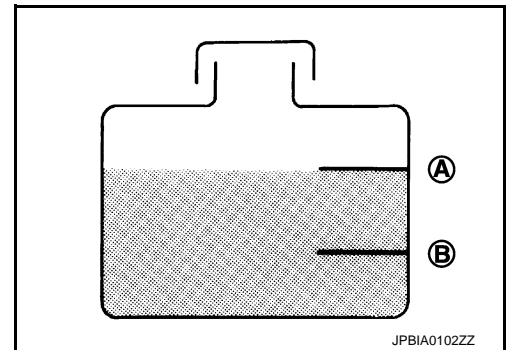

6. Install air duct assembly and air cleaner cases (upper and lower) assembly. Refer to [EM-26, "Exploded View"](#).
 7. Install radiator cap.
 8. Start the engine.
 9. Maintain the engine at 1,800 rpm for approximately 10 seconds. After performing this, stop the engine.
 10. Remove radiator cap with the engine cold (approx. 50°C or less), and check the cooling water level. If the fluid level is low, refill with cooling water to the lip of radiator.
 11. Repeat Steps from 7 to 9 four times.
 12. Cap the radiator, and start the engine.
 13. Warm up engine until opening thermostat. Standard for warming-up time is approximately 10 minutes at 3,000 rpm.
 - Check thermostat opening condition by touching radiator hose (lower) to see a flow of warm water.
- CAUTION:**
Watch water temperature gauge so as not to overheat engine.
14. Stop the engine and cool down to less than approximately 50°C (122°F).
 - Cool down using fan to reduce the time.
 - If necessary, refill radiator up to filler neck with engine coolant.
- CAUTION:**
Never adhere the engine coolant to electronic equipments. (alternator etc.)
15. Refill reservoir tank to "MAX" level line with engine coolant.
 16. Repeat steps 7 through 10 two or more times with radiator cap installed until engine coolant level no longer drops.
 17. Check cooling system for leakage with engine running.
 18. Warm up the engine, and check for sound of engine coolant flow while running engine from idle up to 3,000 rpm with heater temperature controller set at several position between "COOL" and "WARM".

ENGINE MAINTENANCE

< PERIODIC MAINTENANCE >

- Sound may be noticeable at heater unit.
19. Repeat step 13 three times.
 20. If sound is heard, bleed air from cooling system by repeating step 5, and steps from 7 to 14 until engine coolant level no longer drops.

ENGINE COOLANT : Flushing

INFOID:000000007829823

1. Install reservoir tank if removed and radiator drain plug.

CAUTION:

Be sure to clean drain plug and install with new O-ring.

Tightening torque : Refer to [CO-13, "Exploded View"](#).

If water drain plugs on cylinder block are removed, close and tighten them. Refer to [EM-105, "Disassembly and Assembly"](#).

2. Remove air duct assembly and air cleaner cases (upper and lower) assembly. Refer to [EM-26, "Exploded View"](#).
3. Remove air bleeder plug.
4. Fill with cooling water until it overflows from the bleeder plug.
5. Install air bleeder plug.
6. Fill radiator and reservoir tank with water and reinstall radiator cap.
CAUTION:
Never adhere the water to electronic equipments. (alternator etc.)
 - **When water overflows disconnected heater hose, connect heater hose, and continue filling the water.**
7. Install air duct assembly and air cleaner cases (upper and lower) assembly. Refer to [EM-26, "Exploded View"](#).
8. Run the engine and warm it up to normal operating temperature.
9. Rev the engine two or three times under no-load.
10. Stop the engine and wait until it cools down.
11. Drain water from the system. Refer to [CO-8, "Draining"](#).
12. Repeat steps 1 through 11 until clear water begins to drain from radiator.

RADIATOR CAP

RADIATOR CAP : Inspection

INFOID:000000007494699

- Check valve seat (A) of radiator cap.
- Check if valve seat is swollen to the extent that the edge of the plunger (B) cannot be seen when watching it vertically from the top.
- Check if valve seat has no soil and damage.
- Check that there is no dirt or damage on the valve seat of radiator cap negative-pressure valve.
- Check that there are no unusualness in the opening and closing conditions of negative-pressure valve.

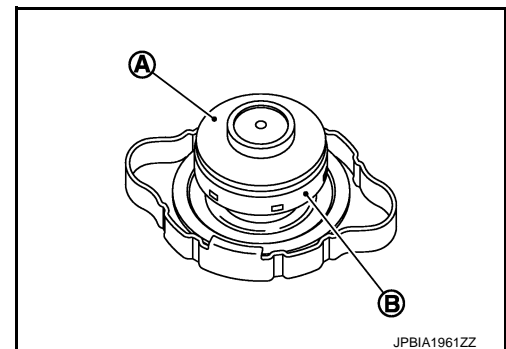

ENGINE MAINTENANCE

< PERIODIC MAINTENANCE >

- Check radiator cap relief pressure.

Standard and limit : Refer to [CO-28, "Radiator"](#).

- When connecting radiator cap to the radiator cap tester (commercial service tool) and the radiator cap tester adapter (commercial service tool) (A), apply engine coolant to the cap seal surface.

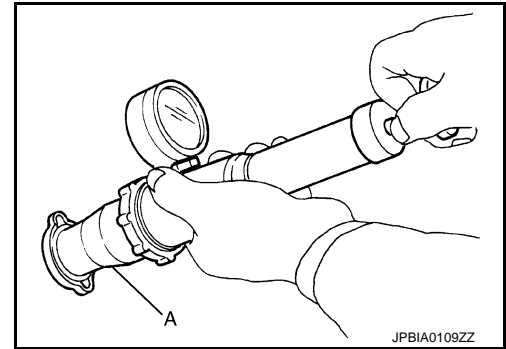

- Replace radiator cap if there is an unusualness related to the above three.

CAUTION:

When installing radiator cap, thoroughly wipe out the radiator pipe (upper) filler neck to remove any waxy residue or foreign material.

RADIATOR

RADIATOR : Inspection

INFOID:000000007494700

Check radiator for mud or clogging. If necessary, clean radiator as follows:

CAUTION:

- **Be careful not to bend or damage radiator fins.**
 - **When radiator is cleaned without removal, remove all surrounding parts such as radiator cooling fan assembly and horns. Then tape harness and connectors to prevent water from entering.**
1. Apply water by hose to the back side of the radiator core vertically downward.
 2. Apply water again to all radiator core surfaces once per minute.
 3. Stop washing if any stains no longer flow out from radiator.
 4. Blow air into the back side of radiator core vertically downward.
 - Use compressed air lower than 490 kPa (5 kg/cm², 71 psi) and keep distance more than 30 cm (11.81 in).
 5. Blow air again into all the radiator core surfaces once per minute until no water sprays out.

FUEL LINES

FUEL LINES : Inspection

INFOID:000000007494701

- Inspect fuel lines, fuel filler cap and fuel tank for improper attachment, leakage, cracks, damage, loose connections, chafing or deterioration.

- A : Engine
- B : Fuel line
- C : Fuel tank

- If necessary, repair or replace damaged parts.

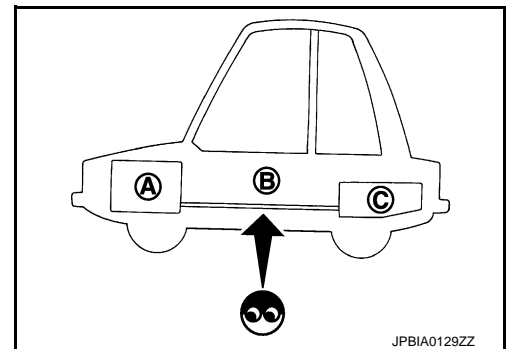

AIR CLEANER FILTER

AIR CLEANER FILTER : Removal and Installation

INFOID:000000007494702

REMOVAL

1. Unhook air cleaner case (lower) side clips and lift up air cleaner case (upper).
2. Remove air cleaner filter and holder assembly from air cleaner case (lower).

INSTALLATION

Note the following, and install in the reverse order of removal.

ENGINE MAINTENANCE

< PERIODIC MAINTENANCE >

- Insert pawls (B) of air cleaner case (upper) (1) into 3 notches (A) of air cleaner case (lower) (2) and fix with clips.

↶ :Vehicle front

- Check that the air cleaner case (upper) is securely installed with no backlash.

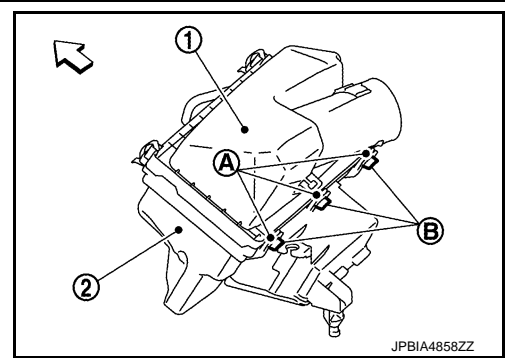

ENGINE OIL

ENGINE OIL : Draining

INFOID:000000007494703

WARNING:

- Be careful not to get burn yourself, as engine oil may be hot.
- Prolonged and repeated contact with used engine oil may cause skin cancer. Try to avoid direct skin contact with used engine oil. If skin contact is made, wash thoroughly with soap or hand cleaner as soon as possible.

1. Warm up the engine, and check for engine oil leakage from engine components. Refer to [LU-7, "Inspection"](#).
2. Stop the engine and wait for 10 minutes.
3. Loosen oil filler cap.
4. Remove drain plug (1) and then drain engine oil.

↶ : Vehicle front

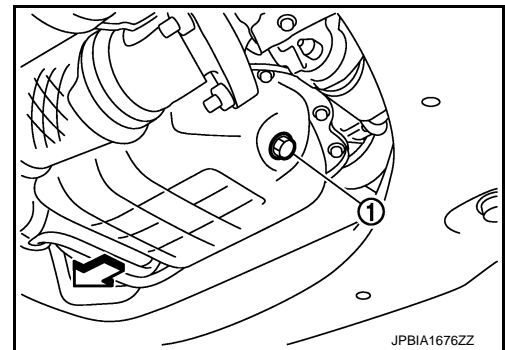

ENGINE OIL : Refilling

INFOID:000000007494704

1. Install drain plug with new drain plug washer. Refer to [EM-38, "Exploded View"](#).

CAUTION:

Be sure to clean drain plug and install with new drain plug washer.

Tightening torque : Refer to [EM-38, "Exploded View"](#).

2. Refill with new engine oil.
Engine oil specification and viscosity: Refer to [MA-10, "Fluids and Lubricants"](#).

Engine oil capacity : Refer to [LU-16, "Periodical Maintenance Specification"](#).

CAUTION:

- When filling engine oil, never pull out oil level gauge.
 - The refill capacity depends on the engine oil temperature and drain time. Use these specifications for reference only.
 - Always use oil level gauge to determine the proper amount of engine oil in engine.
3. Warm up the engine and check area around drain plug and oil filter for engine oil leakage.
 4. Stop the engine and wait for 10 minutes.
 5. Check the engine oil level. Refer to [LU-7, "Inspection"](#).

OIL FILTER

ENGINE MAINTENANCE

< PERIODIC MAINTENANCE >

OIL FILTER : Removal and Installation

INFOID:000000007494705

REMOVAL

CAUTION:

- Oil filter is provided with relief valve. Use genuine NISSAN oil filter or equivalent.
- Be careful not to get burned when engine and engine oil may be hot.
- When removing, prepare a shop cloth to absorb any engine oil leakage or spillage.
- Never allow engine oil to adhere to drive belt.
- Completely wipe off any engine oil that adheres to engine and vehicle.

1. Remove splash guard (RH). Refer to [EXT-22. "Exploded View"](#).
2. Using oil filter wrench [SST: KV10115801 (J-38956)] (A), remove oil filter.

← : Vehicle front

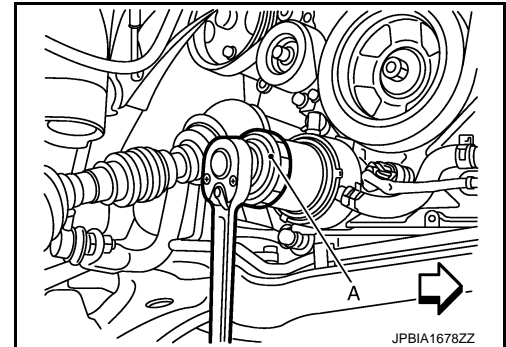

INSTALLATION

1. Remove foreign materials adhering to oil filter installation surface.
2. Apply engine oil to the oil seal contact surface of new oil filter.

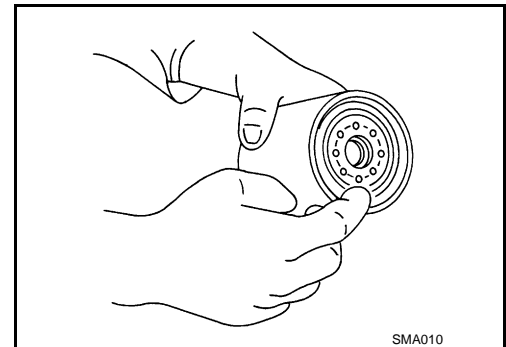

3. Screw oil filter manually until it touches the installation surface, then tighten it by 2/3 turn (A). Or tighten to the specification.

Oil filter:

: 17.6 N·m (1.8 kg·m, 13 ft·lb)

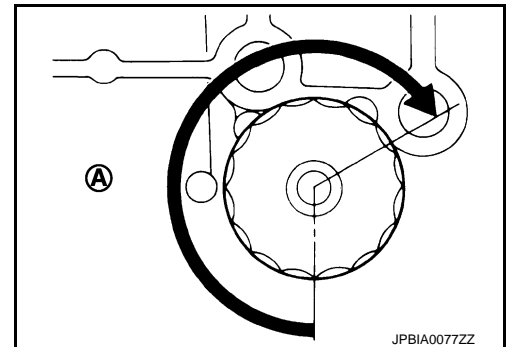

OIL FILTER : Inspection

INFOID:000000007494706

INSPECTION AFTER INSTALLATION

1. Check the engine oil level. Refer to [LU-7. "Inspection"](#).
2. Start the engine, and check there is no leakage of engine oil.
3. Stop the engine and wait for 10 minutes.
4. Check the engine oil level, and adjust the level. Refer to [LU-7. "Inspection"](#).

SPARK PLUG

ENGINE MAINTENANCE

< PERIODIC MAINTENANCE >

SPARK PLUG : Removal and Installation

INFOID:000000007494707

REMOVAL

CAUTION:

Do not reuse O-rings.

1. Remove engine cover. Refer to [EM-24. "Exploded View"](#).
2. Remove air cleaner cases (upper and lower) and air duct assembly. Refer to [EM-26. "Exploded View"](#).
3. Remove intake manifold collector. Refer to [EM-28. "Exploded View"](#).
4. Remove ignition coil. Refer to [EM-52. "Exploded View"](#).
5. Remove spark plug with a spark plug wrench (commercial service tool).

a : 14 mm (0.55 in)

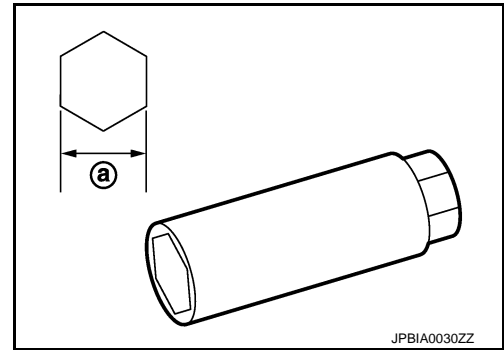

INSTALLATION

Install in the reverse order of removal.

SPARK PLUG : Inspection

INFOID:000000007494708

INSPECTION AFTER REMOVAL

Use the standard type spark plug for normal condition.

Spark plug (Standard type) : Refer to [MA-30. "SPARK PLUG : Spark Plug"](#).

CAUTION:

- Never drop or shock spark plug.
- Never use a wire brush for cleaning.
- If plug tip is covered with carbon, spark plug cleaner may be used.

Cleaner air pressure: Less than 588 kPa (6 kg/cm², 85 psi)

Cleaning time: Less than 20 seconds

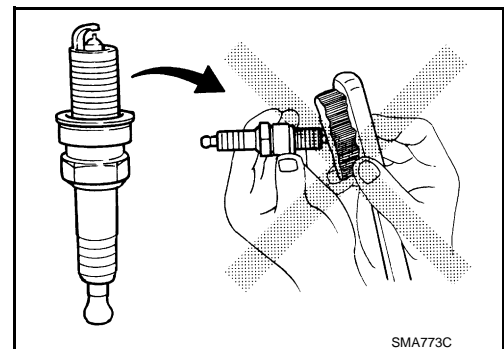

- Spark plug gap adjustment is not required between replacement intervals.
- Measure spark plug gap. When it exceeds the limit, replace spark plug even if it is within the specified replacement mileage. Refer to [MA-30. "SPARK PLUG : Spark Plug"](#).

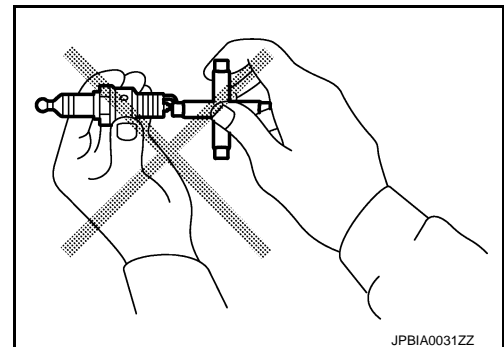

POSITIVE CRANKCASE VENTILATION SYSTEM

A
B
C
D
E
F
G
H
I
J
K
L
M
N
O

MA

ENGINE MAINTENANCE

< PERIODIC MAINTENANCE >

POSITIVE CRANKCASE VENTILATION SYSTEM : Work Procedure

INFOID:000000007494709

1. CHECK PCV VALVE

With engine running at idle, remove PCV valve from rocker cover. A properly working valve makes a hissing noise as air passes through it. A strong vacuum should be felt immediately when a finger is placed over valve inlet.

Is the inspection result normal?

YES >> INSPECTION END

NO >> Replace PCV valve. Refer to [.EM-52. "Exploded View"](#)

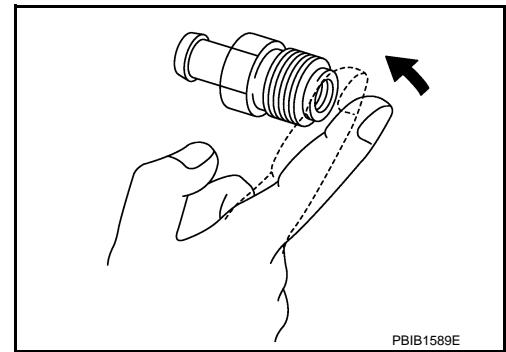

EVAP VAPOR LINES

EVAP VAPOR LINES : Inspection

INFOID:000000007494710

1. Visually inspect EVAP vapor lines for improper attachment and for cracks, damage, loose connections, chafing and deterioration. Refer to [EC-455. "Work Procedure"](#).
2. Inspect fuel tank filler cap vacuum relief valve for clogging, sticking, etc. Refer to [EC-317. "Component Inspection"](#).

CHASSIS MAINTENANCE

< PERIODIC MAINTENANCE >

CHASSIS MAINTENANCE

EXHAUST SYSTEM

EXHAUST SYSTEM : Inspection

INFOID:000000007494711

Check exhaust pipes, muffler, and mounting for improper attachment, leakage, cracks, damage or deterioration.

- If anything is found, repair or replace damaged parts.

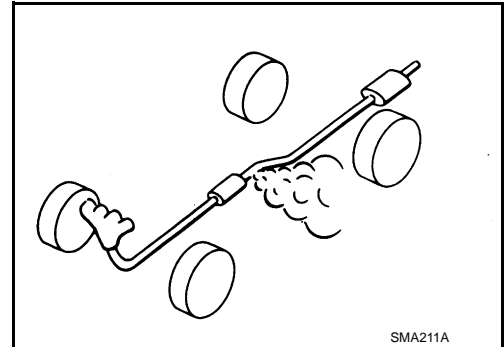

CVT FLUID

CVT FLUID : Inspection

INFOID:000000007494712

CHECKING CVT FLUID

The fluid level should be checked with the fluid warmed up to 50 to 80°C (122 to 176°F). The fluid level check procedure is as follows:

1. Check for fluid leakage.
2. With the engine warmed up, drive the vehicle in an urban area. When ambient temperature is 20°C (68°F), it takes about 10 minutes for the CVT fluid to warm up to 50 to 80°C (122 to 176°F).
3. Park the vehicle on a level surface.
4. Apply parking brake firmly.
5. With engine at idle, while depressing brake pedal, move shift selector throughout the entire shift range.
6. Pull out the CVT fluid level gauge from the CVT fluid charging pipe after pressing the tab on the CVT fluid level gauge to release the lock.

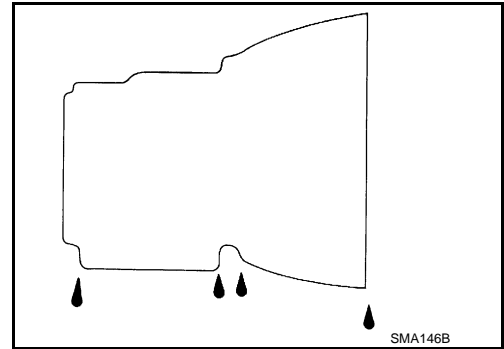

7. Wipe fluid off the CVT fluid level gauge. Insert the CVT fluid level gauge rotating 180° from the originally installed position, then securely push the CVT fluid level gauge until it meets the top end of the CVT fluid charging pipe.

CAUTION:

When wiping away the CVT fluid level gauge, always use lint-free paper, not a cloth rag.

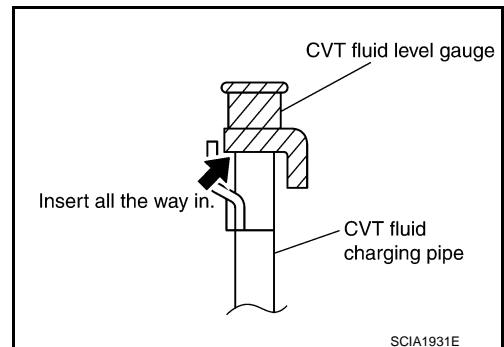
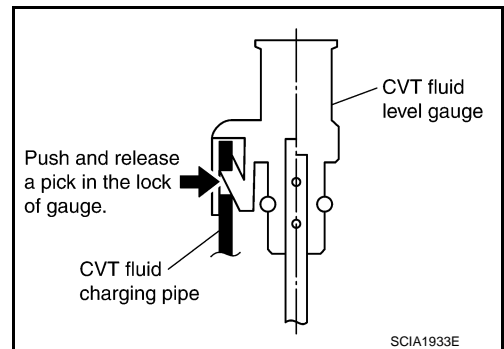

A
B
C
D
E
F
G
H
I
J
K
L
M
N
O

MA

CHASSIS MAINTENANCE

< PERIODIC MAINTENANCE >

8. Place the selector lever in “P” or “N” and check that the fluid level is within the specified range.

CAUTION:

When reinstalling CVT fluid level gauge, insert it into the CVT fluid charging pipe and rotate it to the original installation position until securely locked.

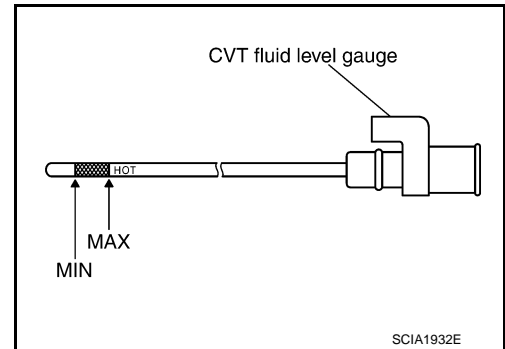

CVT FLUID CONDITION

Check CVT fluid condition.

- If CVT fluid is very dark or smells burned, check operation of CVT. Flush cooling system after repair of CVT.
- If CVT fluid contains frictional material (clutches, brakes, etc.), replace radiator and flush cooler line using cleaning solvent and compressed air after repair of CVT. Refer to [TM-142, "Cleaning"](#).

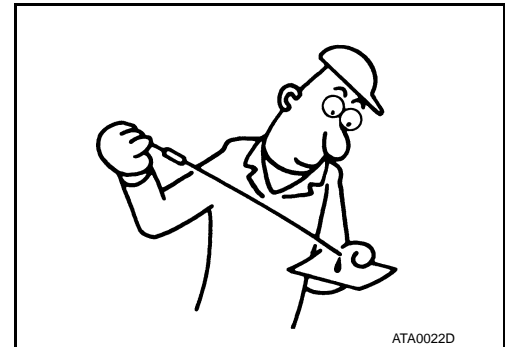

Fluid status	Conceivable cause	Required operation
Varnished (viscous varnish state)	CVT fluid becomes degraded due to high temperatures.	Replace the CVT fluid and check the CVT main unit and the vehicle for malfunctions (wire harnesses, cooler pipes, etc.)
Milky white or cloudy	Water in the fluid	Replace the CVT fluid and check for places where water is getting in.
Large amount of metal powder mixed in	Unusual wear of sliding parts within CVT	Replace the CVT fluid and check for improper operation of the CVT.

WHEELS

WHEELS : Wheel Balance Adjustment

INFOID:000000007494713

PREPARATION BEFORE ADJUSTMENT

Using releasing agent, remove double-faced adhesive tape from the road wheel.

CAUTION:

- **Be careful not to scratch the road wheel during removal.**
- **After removing double-faced adhesive tape, wipe clean traces of releasing agent from the road wheel.**

ADJUSTMENT (ALUMINUM WHEEL)

- The details of the adjustment procedure are different for each model of wheel balancer. Therefore, refer to each instruction manual.
- If a tire balance machine has adhesion balance weight mode settings and drive-in weight mode setting, select and adjust a drive-in weight mode suitable for aluminum wheels.

1. Set road wheel on tire balance machine using the center hole as a guide. Start the tire balance machine.
2. When inner and outer unbalance values are shown on the tire balance machine indicator, multiply outer unbalance value by 5/3 to determine balance weight that should be used. Select the outer balance weight with a value closest to the calculated value above and install to the designated outer position of, or at the designated angle in relation to the road wheel.

CAUTION:

- **Never install the inner balance weight before installing the outer balance weight.**
- **Before installing the balance weight, always clean the mating surface of the road wheel.**

CHASSIS MAINTENANCE

< PERIODIC MAINTENANCE >

- a. Indicated unbalance value $\times 5/3 =$ balance weight to be installed

Calculation example:

23 g (0.81 oz) $\times 5/3 = 38.33$ g (1.35 oz) $\Rightarrow 37.5$ g (1.32 oz) balance weight (closer to calculated balance weight value)

NOTE:

Note that balance weight value must be closer to the calculated balance weight value.

Example:

36.2 $\Rightarrow 35$ g (1.23 oz)

36.3 $\Rightarrow 37.5$ g (1.32 oz)

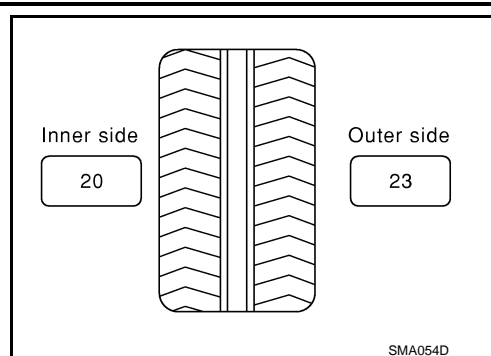

- b. Installed balance weight in the position.

- When installing balance weight (1) to road wheels, set it into the grooved area (A) on the inner wall of the road wheel as shown in the figure so that the balance weight center (B) is aligned with the tire balance machine indication position (angle) (C).

CAUTION:

- Always use genuine NISSAN balance weights.
- Balance weights are non-reusable; always replace with new ones.
- Never install three or more sheets of balance weight.

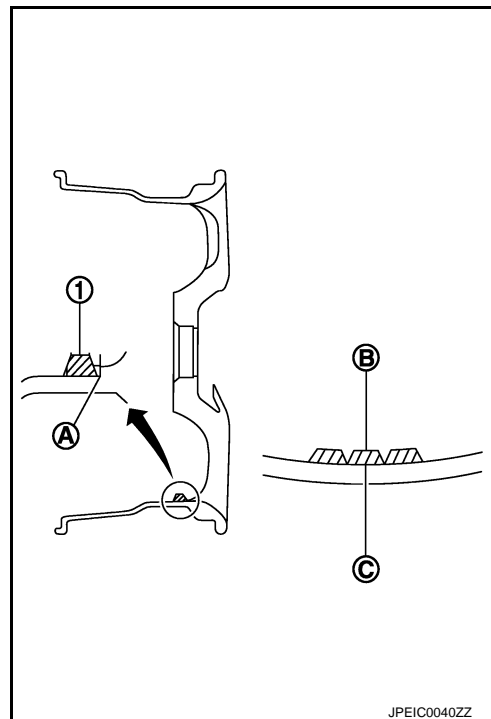

- c. If calculated balance weight value exceeds 50 g (1.76 oz), install two balance weight sheets in line with each other as shown in the figure.

CAUTION:

Never install one balance weight sheet on top of another.

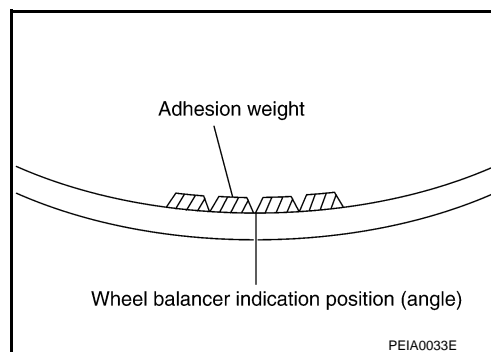

- Start the tire balance machine again.
- Install drive-in balance weight on inner side of road wheel in the tire balance machine indication position (angle).

CAUTION:

Never install three or more balance weight.

- Start the tire balance machine. Check that the inner and outer residual unbalance value is within the allowable unbalance value.

CAUTION:

If either residual unbalance value exceeds limit, repeat installation procedures.

A
B
C
D
E
F
G
H
I
J
K
L
M
N
O

MA

CHASSIS MAINTENANCE

< PERIODIC MAINTENANCE >

Allowable unbalance value

Dynamic (At flange) : Refer to [WT-48, "Road Wheel"](#).

Static (At flange) : Refer to [WT-48, "Road Wheel"](#).

ADJUSTMENT (STEEL WHEEL)

Preparation Before Adjustment

Remove balance weight from the road wheel.

Wheel Balance Adjustment

- The details of the adjustment procedure are different for each model of wheel balancer. Therefore, refer to each instruction manual.
- If a tire balance machine has adhesion balance weight mode settings and drive-in weight mode setting, select and adjust a drive-in weight mode suitable for steel wheels.

1. Set road wheel to wheel balancer, and then start wheel balancer.
2. Install balance weight to road wheel according to the unbalance and position (angle) displayed on wheel balancer.

CAUTION:

- Never install three or more balance weights on one side.
- Always use genuine NISSAN balance weights.
- Balance weights are non-reusable; always replace with new ones.
- Always use a plastic hammer when attaching the weight.

3. Start the tire balance machine. Check that the inner and outer residual unbalance value is within the allowable unbalance value.

CAUTION:

If either residual unbalance value exceeds limit, repeat installation procedures.

Allowable unbalance value

Dynamic (At flange) : Refer to [WT-48, "Road Wheel"](#).

Static (At flange) : Refer to [WT-48, "Road Wheel"](#).

WHEELS : Tire Rotation

INFOID:000000007494714

- Follow the maintenance schedule for tire rotation service intervals. Refer to [MA-4, "Explanation of General Maintenance"](#).
- When installing the wheel, tighten wheel nuts to the specified torque. Refer to [WT-43, "Exploded View"](#).

CAUTION:

- Never include the T-type spare tire when rotating the tires.
 - When installing wheels, tighten them diagonally by dividing the work two to three times in order to prevent the wheels from developing any distortion.
 - Be careful not to tighten wheel nut at torque exceeding the criteria.
 - Use NISSAN genuine wheel nut.
- Perform the ID registration, after tire rotation. Refer to [WT-20, "Work Procedure"](#).

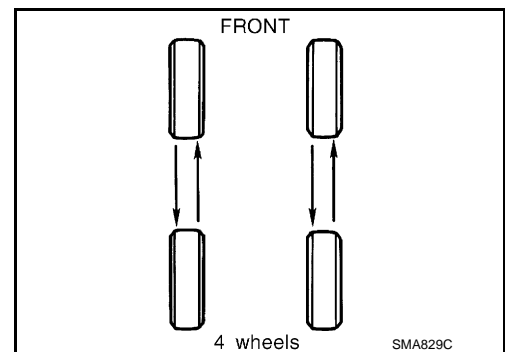

BRAKE FLUID LEVEL AND LEAKS

CHASSIS MAINTENANCE

< PERIODIC MAINTENANCE >

BRAKE FLUID LEVEL AND LEAKS : Inspection

INFOID:000000007494715

- If fluid level is extremely low, check brake system for leaks.

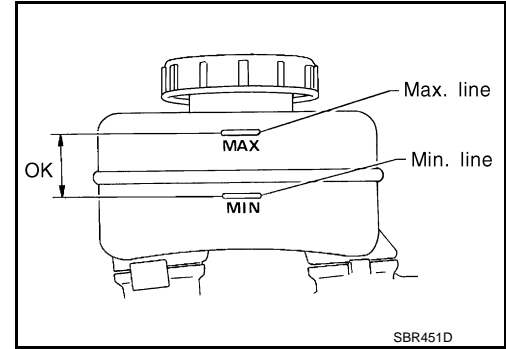

BRAKE LINES AND CABLES

BRAKE LINES AND CABLES : Inspection

INFOID:000000007494716

- Check brake fluid lines and parking brake cables for improper attachment, leaks, chafing, abrasions, deterioration, etc.

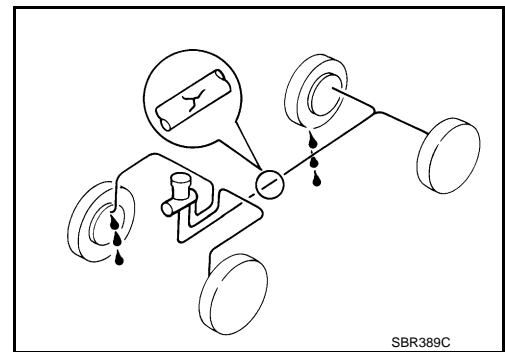

BRAKE FLUID

BRAKE FLUID : Changing

INFOID:000000007494717

1. Drain brake fluid from each bleed valve.
2. Refill until new brake fluid comes out from each bleed valve. Use same procedure as in bleeding hydraulic system to refill brake fluid.
Refer to [BR-11. "Bleeding Brake System"](#).
 - Refill with recommended Genuine NISSAN Super Heavy Duty Brake Fluid or equivalent DOT 3 (US FMVSS No. 116). Refer to [MA-10. "Fluids and Lubricants"](#).
 - Never reuse drained brake fluid.
 - Be careful not to splash brake fluid on painted areas.

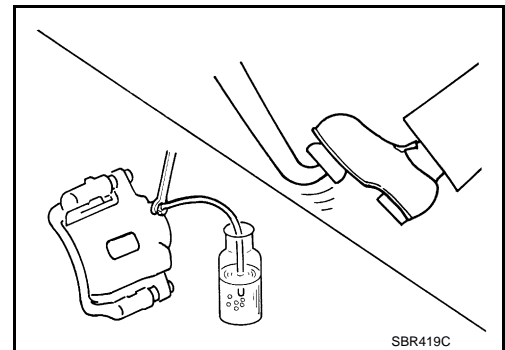

DISC BRAKE

DISC BRAKE : Inspection

INFOID:000000007494718

DISC ROTOR

Check condition, wear, and damage.

CALIPER

- Check for leakage.

A
B
C
D
E
F
G
H
I
J
K
L
M
N
O

MA

CHASSIS MAINTENANCE

< PERIODIC MAINTENANCE >

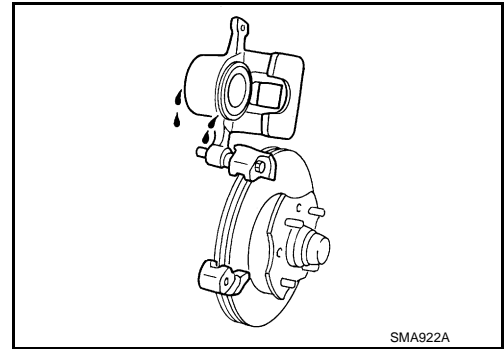

BRAKE PAD

- Check for wear or damage.

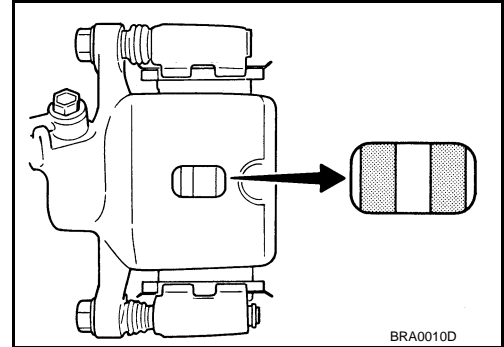

DISC BRAKE : Front Disc Brake

INFOID:000000007494719

Unit: mm (in)

Item		Limit
Brake pad	Wear thickness	2.0 (0.079)
	Wear thickness	26.0 (1.024)
Disc rotor	Runout (with it attached to the vehicle)	0.040 (0.0016)

DISC BRAKE : Rear Disc Brake

INFOID:000000007494720

Unit: mm (in)

Item		Limit
Brake pad	Wear thickness	2.0 (0.079)
	Wear thickness	14.0 (0.551)
Disc rotor	Runout (with it attached to the vehicle)	0.050 (0.0020)

STEERING GEAR AND LINKAGE

STEERING GEAR AND LINKAGE : Inspection

INFOID:000000007494721

STEERING GEAR

- Check gear housing and boots for looseness, damage and grease leakage.
- Check connection with steering column for looseness.

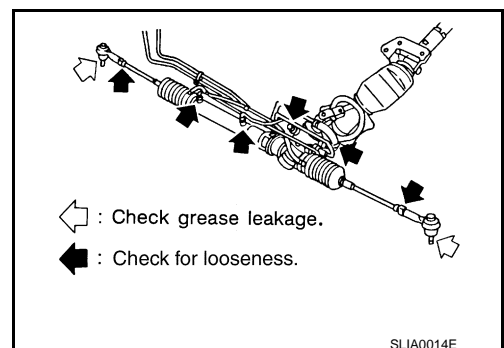

CHASSIS MAINTENANCE

< PERIODIC MAINTENANCE >

STEERING LINKAGE

Check ball joint, dust cover and other component parts for looseness, wear, damage and grease leakage.

POWER STEERING FLUID AND LINES

POWER STEERING FLUID AND LINES : Inspection

INFOID:000000007494722

Check fluid level in reservoir tank with engine off.

Use "HOT" range at fluid temperatures of 50 to 80°C (122 to 176°F) or "COLD" range at fluid temperatures of 0 to 30°C (32 to 86°F).

CAUTION:

- Do not overfill.
- Recommended fluid is Genuine NISSAN E-PSF or equivalent. Refer to [MA-10. "Fluids and Lubricants"](#).

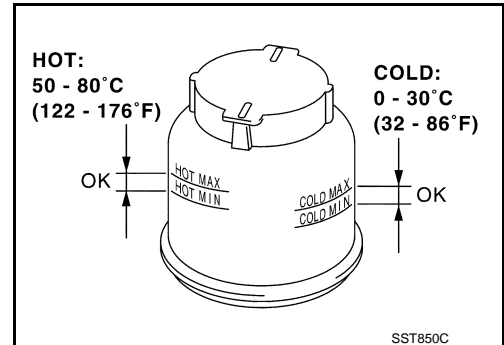

- Check lines for improper attachment, leaks, cracks, damage, loose connections, chafing and deterioration.
- Check rack boots for accumulation of power steering fluid.

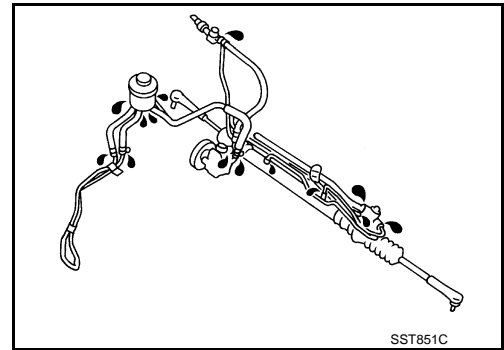

AXLE AND SUSPENSION PARTS

AXLE AND SUSPENSION PARTS : Inspection

INFOID:000000007494723

Check front and rear axle and suspension parts for excessive play, cracks, wear or other damage.

- Shake each wheel to check for excessive play.
- Check wheel bearings for smooth operation.
- Check axle and suspension nuts and bolts for looseness.
- Check strut (shock absorber) for oil leakage or other damage.
- Check suspension ball joint for grease leakage and ball joint dust cover for cracks or other damage.

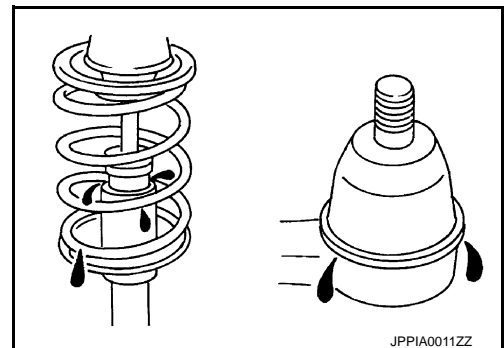
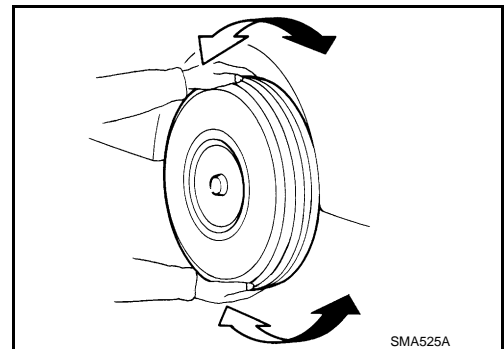

DRIVE SHAFT

A
B
C
D
E
F
G
H
I
J
K
L
M
N
O

MA

CHASSIS MAINTENANCE

< PERIODIC MAINTENANCE >

DRIVE SHAFT : Inspection

INFOID:000000007494724

Check boot and drive shaft for cracks, wear, damage and grease leakage.

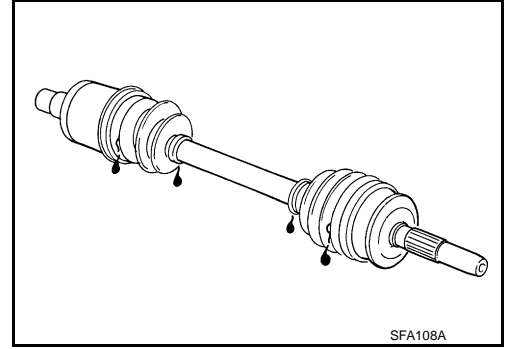

SFA108A

BODY MAINTENANCE

< PERIODIC MAINTENANCE >

BODY MAINTENANCE

LOCKS, HINGES AND HOOD LATCH

LOCKS, HINGES AND HOOD LATCH : Lubricating

INFOID:000000007494725

For hood and hood lock illustration.

- Hood: Refer to [DLK-391, "Exploded View"](#).
- Hood lock: Refer to [DLK-426, "Exploded View"](#).

For door and door lock illustration.

- Front door: Refer to [DLK-399, "Exploded View"](#).
- Front door lock: Refer to [DLK-430, "Exploded View"](#).
- Slide door: Refer to [DLK-404, "Exploded View"](#).
- Slide door lock: Refer to [DLK-433, "Exploded View"](#).

For back door and back door lock illustration.

- Back door: Refer to [DLK-418, "Exploded View"](#).
- Back door lock: Refer to [DLK-443, "Exploded View"](#).

SEAT BELT, BUCKLES, RETRACTORS, ANCHORS AND ADJUSTERS

SEAT BELT, BUCKLES, RETRACTORS, ANCHORS AND ADJUSTERS : Inspection

INFOID:000000007494726

For front seat belt illustration. Refer to [SB-4, "Exploded View"](#).

For second seat belt illustration. Refer to [SB-10, "Exploded View"](#).

For third seat belt illustration. Refer to [SB-15, "Exploded View"](#).

CAUTION:

- **After any collision, inspect all seat belt assemblies, including retractors and other attached hardwares (I.e. anchor bolt, guide rail set). Nissan recommends to replace all seat belt assemblies in use during a collision, unless not damaged and properly operating after minor collision.**

Also inspect seat belt assemblies not in use during a collision, and replace if damaged or improperly operating.

Seat belt pre-tensioner should be replaced even if the seat belts are not in use during a frontal collision where the driver and passenger air bags are deployed.

- **If any component of seat belt assembly is questionable, do not repair.**

Replace as seat belt assembly.

- **If webbing is cut, frayed, or damaged, replace belt assembly.**
- **Never oil tongue and buckle.**
- **Use a genuine NISSAN seat belt assembly.**

For details, refer to [SB-6, "SEAT BELT RETRACTOR : Inspection"](#), [SB-11, "SEAT BELT RETRACTOR : Inspection"](#), [SB-17, "SEAT BELT RETRACTOR : Inspection"](#) in SB section.

- Check anchors for loose mounting
- Check belts for damage
- Check retractor for smooth operation
- Check function of buckles and tongues when buckled and released

A

B

C

D

E

F

G

H

I

J

K

L

M

N

O

MA

SERVICE DATA AND SPECIFICATIONS (SDS)

< SERVICE DATA AND SPECIFICATIONS (SDS)

SERVICE DATA AND SPECIFICATIONS (SDS)

SERVICE DATA AND SPECIFICATIONS (SDS)

DRIVE BELT

DRIVE BELT : Drive Belt

INFOID:000000007494727

DRIVE BELT

Tension of drive belt	Belt tension is not necessary, as it is automatically adjusted by drive belt auto-tensioner.
-----------------------	----------------------------------------------------------------------------------------------

ENGINE COOLANT

ENGINE COOLANT : Periodical Maintenance Specification

INFOID:000000007494728

ENGINE COOLANT CAPACITY (APPROXIMATE)

Unit: ℓ (US qt, Imp qt)

Engine coolant capacity (With reservoir tank at "MAX" level)	11.3 (12, 10)
Reservoir tank	0.75 (6/8, 5/8)

ENGINE OIL

ENGINE OIL : Periodical Maintenance Specification

INFOID:000000007494729

ENGINE OIL CAPACITY (APPROXIMATE)

Unit: ℓ (US qt, Imp qt)

Drain and refill	With oil filter change	4.6 (4-7/8, 4)
	Without oil filter change	4.3 (4-1/2, 3-3/4)
Dry engine (Overhaul)		5.3 (5-5/8, 4-5/8)

SPARK PLUG

SPARK PLUG : Spark Plug

INFOID:000000007494730

SPARK PLUG

Unit: mm (in)

Make	DENSO	
Standard type	FXE22HR11	
Gap	Standard	1.1 (0.043)
	Limit	1.4 (0.055)

ROAD WHEEL

ROAD WHEEL : Road Wheel

INFOID:000000007494731

ALUMINUM WHEEL

Item		Limit
Runout	Axial runout	Less than 0.3 mm (0.012 in)
	Radial runout	
Allowable unbalance	Dynamic (At flange)	Less than 5 g (0.17 oz) (one side)
	Static (At flange)	Less than 10 g (0.35 oz)

STEEL WHEEL

SERVICE DATA AND SPECIFICATIONS (SDS)

< SERVICE DATA AND SPECIFICATIONS (SDS)

Item		Limit
Runout	Axial runout (Average)	Less than 0.8 mm (0.031 in)
	Radial runout (Average)	Less than 0.5 mm (0.020 in)
Allowable unbalance	Dynamic (At flange)	Less than 5 g (0.17 oz) (one side)
	Static (At flange)	Less than 10 g (0.35 oz)

STEEL WHEEL (EMERGENCY)

Item		Limit
Runout	Axial runout (Average)	Less than 1.5 mm (0.059 in)
	Radial runout (Average)	

A
B
C
D
E
F
G
H
I
J
K
L
M
N
O

MA