

# STC

SECTION

## STEERING CONTROL SYSTEM

A  
B  
C  
D  
E  
F  
G  
H  
I  
J  
K  
L  
M  
N  
O  
P

STC

### CONTENTS

<p><b>PRECAUTION</b> ..... 3</p> <p><b>PRECAUTIONS</b> ..... 3</p> <p style="padding-left: 20px;">Precaution for Supplemental Restraint System (SRS) "AIR BAG" and "SEAT BELT PRE-TENSIONER" .....3</p> <p style="padding-left: 20px;">Service Notice and Precautions for Hydraulic Pump Electric Power Steering System .....3</p> <p><b>SYSTEM DESCRIPTION</b> ..... 4</p> <p><b>COMPONENT PARTS</b> ..... 4</p> <p style="padding-left: 20px;">Component Parts Location .....4</p> <p style="padding-left: 20px;">Power Steering Oil Pump Assembly .....5</p> <p><b>SYSTEM</b> ..... 6</p> <p><b>HYDRAULIC PUMP ELECTRIC POWER STEERING SYSTEM</b> .....6</p> <p style="padding-left: 20px;">HYDRAULIC PUMP ELECTRIC POWER STEERING SYSTEM : System Description .....6</p> <p style="padding-left: 20px;">HYDRAULIC PUMP ELECTRIC POWER STEERING SYSTEM : Fail-safe .....8</p> <p style="padding-left: 20px;">HYDRAULIC PUMP ELECTRIC POWER STEERING SYSTEM : Protection Function .....9</p> <p><b>DIAGNOSIS SYSTEM (POWER STEERING CONTROL MODULE)</b> .....10</p> <p style="padding-left: 20px;">CONSULT Function ..... 10</p> <p><b>ECU DIAGNOSIS INFORMATION</b> .....11</p> <p><b>POWER STEERING CONTROL MODULE</b> .....11</p> <p style="padding-left: 20px;">Reference Value ..... 11</p> <p style="padding-left: 20px;">Fail-safe ..... 12</p> <p style="padding-left: 20px;">Protection Function ..... 12</p> <p style="padding-left: 20px;">DTC Inspection Priority Chart ..... 13</p> <p style="padding-left: 20px;">DTC Index ..... 13</p> <p><b>WIRING DIAGRAM</b> .....14</p>	<p><b>HYDRAULIC PUMP ELECTRIC POWER STEERING SYSTEM</b> .....14</p> <p style="padding-left: 20px;">Wiring Diagram .....14</p> <p><b>BASIC INSPECTION</b> ..... 15</p> <p><b>DIAGNOSIS AND REPAIR WORK FLOW</b> .....15</p> <p style="padding-left: 20px;">Work Flow .....15</p> <p style="padding-left: 20px;">Diagnostic Work Sheet .....16</p> <p><b>DTC/CIRCUIT DIAGNOSIS</b> .....18</p> <p><b>C1143 STEERING ANGLE SENSOR</b> .....18</p> <p style="padding-left: 20px;">DTC Logic .....18</p> <p style="padding-left: 20px;">Diagnosis Procedure .....18</p> <p><b>C1601 BATTERY POWER SUPPLY</b> .....19</p> <p style="padding-left: 20px;">DTC Logic .....19</p> <p style="padding-left: 20px;">Diagnosis Procedure .....19</p> <p><b>C1606 EPS MOTOR</b> .....22</p> <p style="padding-left: 20px;">DTC Logic .....22</p> <p style="padding-left: 20px;">Diagnosis Procedure .....22</p> <p><b>C1607, C1608 POWER STEERING CONTROL MODULE</b> .....23</p> <p style="padding-left: 20px;">DTC Logic .....23</p> <p style="padding-left: 20px;">Diagnosis Procedure .....23</p> <p><b>C160A HEAT PROTECTION</b> .....24</p> <p style="padding-left: 20px;">DTC Logic .....24</p> <p><b>U1000 CAN COMM CIRCUIT</b> .....25</p> <p style="padding-left: 20px;">Description .....25</p> <p style="padding-left: 20px;">DTC Logic .....25</p> <p style="padding-left: 20px;">Diagnosis Procedure .....25</p> <p><b>HYDRAULIC PUMP ELECTRIC POWER STEERING WARNING LAMP</b> .....26</p> <p style="padding-left: 20px;">Component Function Check .....26</p> <p style="padding-left: 20px;">Diagnosis Procedure .....26</p> <p><b>SYMPTOM DIAGNOSIS</b> .....27</p>
---	--

---

<b>HYDRAULIC PUMP ELECTRIC POWER STEERING WARNING LAMP DOES NOT TURN ON .....</b>	<b>27</b>	<b>UNBALANCE STEERING WHEEL TURNING FORCE AND RETURN BETWEEN RIGHT AND LEFT .....</b>	<b>31</b>
Description .....	27	Diagnosis Procedure .....	31
Diagnosis Procedure .....	27	<b>UNBALANCE STEERING WHEEL TURNING FORCE (TORQUE VARIATION) .....</b>	<b>32</b>
<b>HYDRAULIC PUMP ELECTRIC POWER STEERING WARNING LAMP DOES NOT TURN OFF .....</b>	<b>28</b>	Diagnosis Procedure .....	32
Description .....	28	<b>REMOVAL AND INSTALLATION .....</b>	<b>34</b>
Diagnosis Procedure .....	28	<b>POWER STEERING CONTROL MODULE .....</b>	<b>34</b>
<b>STEERING WHEEL TURNING FORCE IS HEAVY OR LIGHT .....</b>	<b>29</b>	Removal and Installation .....	34
Diagnosis Procedure .....	29		

# PRECAUTIONS

< PRECAUTION >

## PRECAUTION

### PRECAUTIONS

#### Precaution for Supplemental Restraint System (SRS) "AIR BAG" and "SEAT BELT PRE-TENSIONER"

INFOID:000000007492022

The Supplemental Restraint System such as "AIR BAG" and "SEAT BELT PRE-TENSIONER", used along with a front seat belt, helps to reduce the risk or severity of injury to the driver and front passenger for certain types of collision. This system includes seat belt switch inputs and dual stage front air bag modules. The SRS system uses the seat belt switches to determine the front air bag deployment, and may only deploy one front air bag, depending on the severity of a collision and whether the front occupants are belted or unbelted. Information necessary to service the system safely is included in the "SRS AIR BAG" and "SEAT BELT" of this Service Manual.

#### **WARNING:**

**Always observe the following items for preventing accidental activation.**

- **To avoid rendering the SRS inoperative, which could increase the risk of personal injury or death in the event of a collision that would result in air bag inflation, all maintenance must be performed by an authorized NISSAN/INFINITI dealer.**
- **Improper maintenance, including incorrect removal and installation of the SRS, can lead to personal injury caused by unintentional activation of the system. For removal of Spiral Cable and Air Bag Module, see "SRS AIR BAG".**
- **Never use electrical test equipment on any circuit related to the SRS unless instructed to in this Service Manual. SRS wiring harnesses can be identified by yellow and/or orange harnesses or harness connectors.**

#### PRECAUTIONS WHEN USING POWER TOOLS (AIR OR ELECTRIC) AND HAMMERS

#### **WARNING:**

**Always observe the following items for preventing accidental activation.**

- **When working near the Air Bag Diagnosis Sensor Unit or other Air Bag System sensors with the ignition ON or engine running, never use air or electric power tools or strike near the sensor(s) with a hammer. Heavy vibration could activate the sensor(s) and deploy the air bag(s), possibly causing serious injury.**
- **When using air or electric power tools or hammers, always switch the ignition OFF, disconnect the battery, and wait at least 3 minutes before performing any service.**

#### Service Notice and Precautions for Hydraulic Pump Electric Power Steering System

INFOID:000000007492023

- Check if air pressure and size of tires are proper, the specified part is used for the steering wheel is genuine part.
- Check if the connection of steering column assembly and steering gear assembly is proper (there is not looseness of mounting bolts, damage of rods, boots or sealants, and leakage of grease, etc.).
- Check if the wheel alignment is adjusted properly.
- Check if there is any damage or modification to suspension or body resulting in increased weight or altered ground clearance.
- Check if installation conditions of each link and suspension are proper.
- Check if the battery voltage is proper.
- Check connection conditions of each connector are proper.
- Check that NISSAN genuine power steering fluid (E-PSF) is used. If power steering fluid other than genuine fluid is used, steering may become extremely hard.
- You may hear a high pitch noise from the front of the vehicle when the steering wheel is operated, especially at low speed such as a parking lot. However this is not a malfunction. Steer at low speed condition makes higher load for steering rack, so pump works higher rotation to provide more hydraulic flow to create more power assistance for lighter steering effort. This pump rotation is electrically controlled based on rotation map in ECU.
- Before connecting or disconnecting the power steering control module harness connector, turn ignition switch "OFF" and disconnect battery ground cable. Because battery voltage is applied to power steering control module even if ignition switch is turned "OFF".

# COMPONENT PARTS

< SYSTEM DESCRIPTION >

## SYSTEM DESCRIPTION

### COMPONENT PARTS

#### Component Parts Location

INFOID:000000007492024

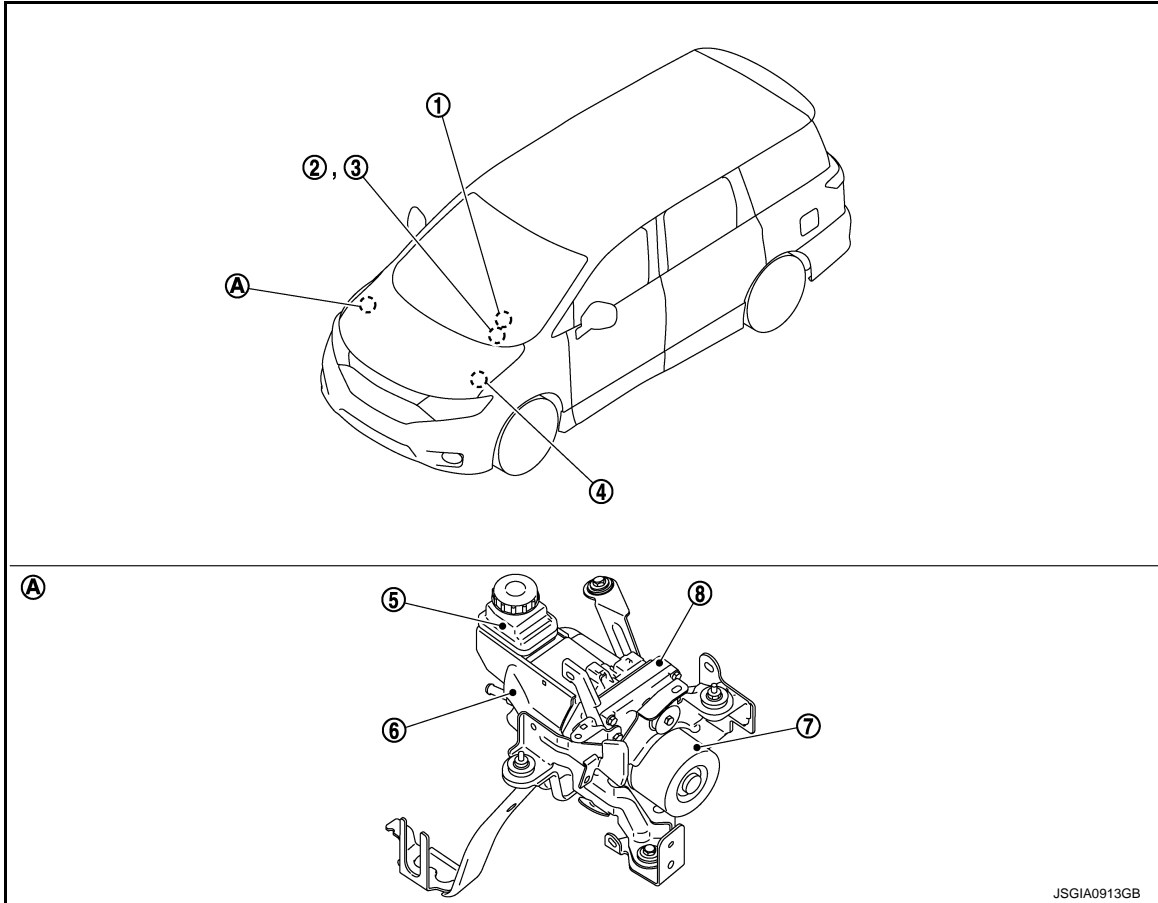

A. Engine room right side

No.	Component	Function
1.	Steering angle sensor	Transmits mainly the following signals to power steering control module via CAN communication. <ul style="list-style-type: none"> <li>Steering angle sensor signal</li> </ul>
2.	Combination meter	Transmits mainly the following signals to power steering control module via CAN communication. <ul style="list-style-type: none"> <li>Vehicle speed signal</li> </ul> Refer to <a href="#">MWI-6, "METER SYSTEM : Component Parts Location"</a> for detailed installation location. <p>The hydraulic pump electric power steering system warning lamp turns ON according to the signal received by CAN communication from the power steering control module.</p>
3.	Hydraulic pump electric power steering system warning lamp (In combination meter)	<a href="#">STC-6, "HYDRAULIC PUMP ELECTRIC POWER STEERING SYSTEM : System Description"</a>
4.	ECM	Transmits mainly the following signals to power steering control module via CAN communication. <ul style="list-style-type: none"> <li>Engine status signal</li> </ul> Refer to <a href="#">EC-15, "ENGINE CONTROL SYSTEM : Component Parts Location"</a> for detailed installation location.

# COMPONENT PARTS

## < SYSTEM DESCRIPTION >

No.	Component	Function
5.	Reservoir tank	<a href="#">STC-5. "Power Steering Oil Pump Assembly"</a>
6.	Power steering oil pump	
7.	Power steering motor	
8.	Power steering control module	

### Power Steering Oil Pump Assembly

INFOID:000000007492025

The power steering oil pump assembly is primarily composed of the reservoir tank (1), power steering oil pump (2), power steering motor (3), and power steering control module (4).

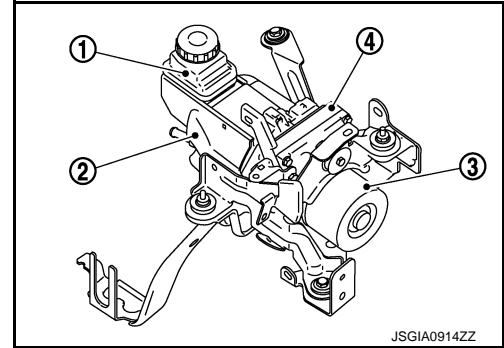

#### RESERVOIR TANK

Fluid is filled from the reservoir tank.

#### POWER STEERING OIL PUMP

The power steering oil pump is driven by the power steering motor and generates hydraulic oil pressure in the system.

#### POWER STEERING MOTOR

The power steering motor is controlled by the power steering control module and drives the power steering oil pump.

#### POWER STEERING CONTROL MODULE

By receiving steering angle sensor signal and vehicle speed signal, the power steering control module calculates hydraulic pressure of the hydraulic pump electric power steering system according to the driving conditions. The power steering control module controls the power steering motor.

A  
B  
C  
D  
E  
F  
STC  
H  
I  
J  
K  
L  
M  
N  
O  
P

# SYSTEM

< SYSTEM DESCRIPTION >

## SYSTEM

### HYDRAULIC PUMP ELECTRIC POWER STEERING SYSTEM

### HYDRAULIC PUMP ELECTRIC POWER STEERING SYSTEM : System Description

INFOID:000000007492026

- The system is composed primarily of the power steering oil pump assembly (power steering control module, power steering motor, power steering oil pump, and reservoir tank), hydraulic pipes, and steering gear assembly.
- The power steering control module controls the speed of the power steering motor according to the vehicle speed and steering angle speed. By changing the power steering oil pump flow, the power steering control module controls the steering assist force.
- According to the power steering motor control, the system hydraulic pressure is transmitted from the power steering motor to power steering oil pump. The power steering oil pump is driven by the system hydraulic pressure.
- After engine start, the hydraulic pump electric power steering system performs control.
- When a malfunction occurs in the system, the fail-safe function stops the hydraulic pump electric power steering system (manual steering state) or restricts its operation (certain steering assist force). Refer to [STC-8, "HYDRAULIC PUMP ELECTRIC POWER STEERING SYSTEM : Fail-safe"](#).
- When the power steering function is used continuously in an extreme manner, the protective function reduces the output to the power steering motor. Refer to [STC-9, "HYDRAULIC PUMP ELECTRIC POWER STEERING SYSTEM : Protection Function"](#).

### SYSTEM DIAGRAM

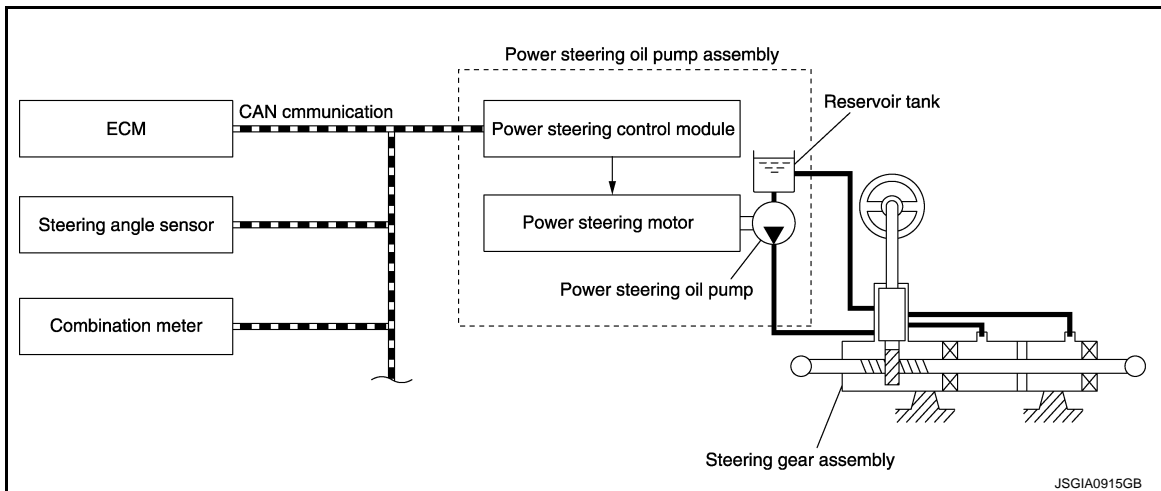

### INPUT/OUTPUT SIGNAL

Communicates the signal from each control unit via CAN communication.

Control unit	Signal status
ECM	Transmits mainly the following signals to power steering control module via CAN communication. <ul style="list-style-type: none"> <li>• Engine status signal</li> </ul>
Steering angle sensor	Transmits mainly the following signals to power steering control module via CAN communication. <ul style="list-style-type: none"> <li>• Steering angle sensor signal</li> </ul>
Combination meter	Transmits mainly the following signals to power steering control module via CAN communication. <ul style="list-style-type: none"> <li>• Vehicle speed signal</li> </ul>
	Receives mainly the following signals from power steering control module via CAN communication. <ul style="list-style-type: none"> <li>• Hydraulic pump electric power steering warning lamp signal</li> </ul>

### OPERATION CHARACTERISTICS

# SYSTEM

## < SYSTEM DESCRIPTION >

When the steering angle speed is high or the vehicle speed is low, force is generated by increasing discharge amount from the power steering oil pump and by raising system hydraulic pressure.

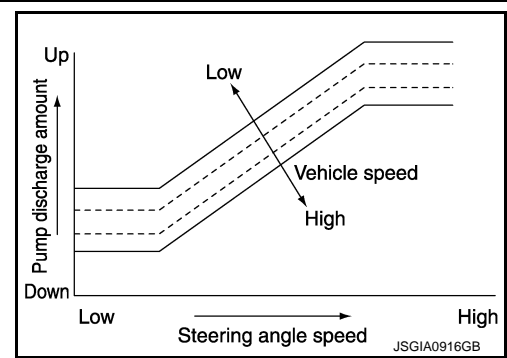

## OPERATION PRINCIPLE

When Steering Wheel is in the Neutral Position

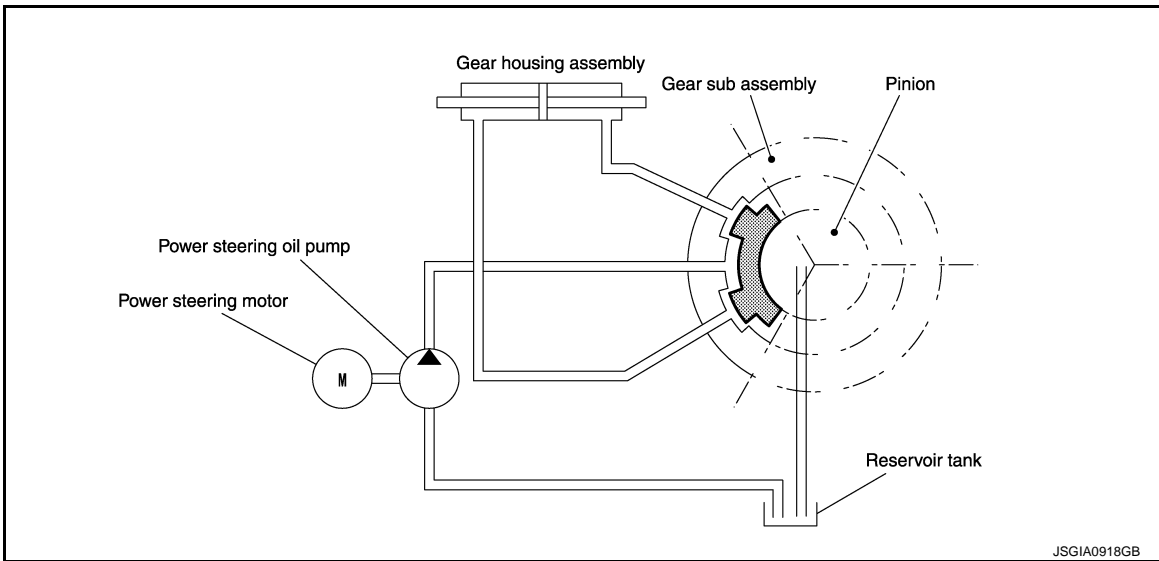

Because the hydraulic routes open at the power steering pump, gear housing right side, gear housing left side, and reservoir tank, the hydraulic pressure applied to the right side and left side of the gear housing is equal and no steering assist force is generated.

When Steering Wheel is Rotated to the Right

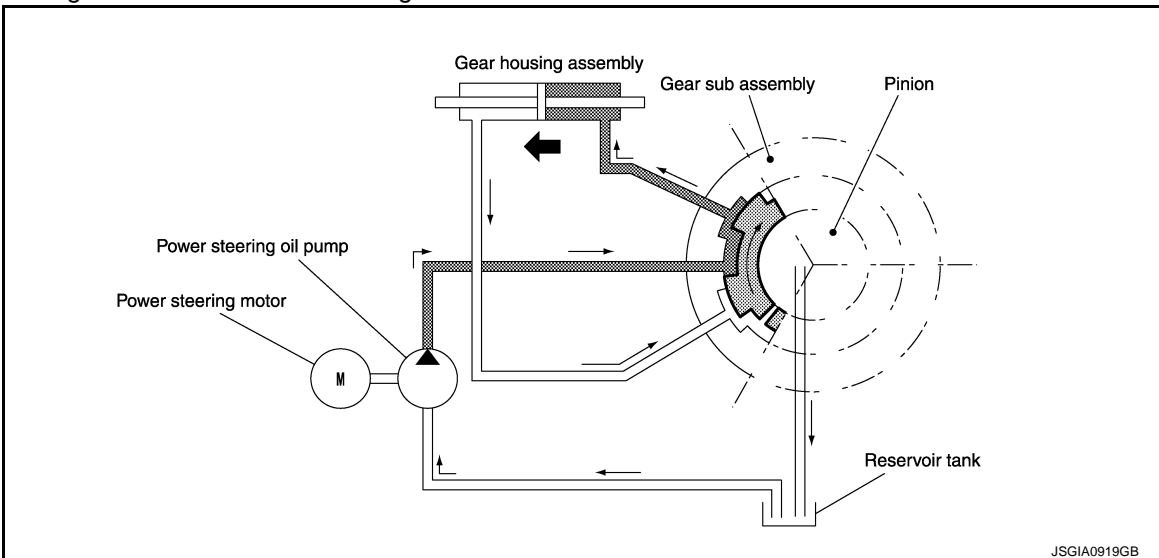

The hydraulic routes open from power steering pump to gear housing right side and from gear housing left side to reservoir tank, providing left direction assist force to the rack.

A  
B  
C  
D  
E  
F  
STC  
H  
I  
J  
K  
L  
M  
N  
O  
P

# SYSTEM

## < SYSTEM DESCRIPTION >

When Steering Wheel is Rotated to the Left

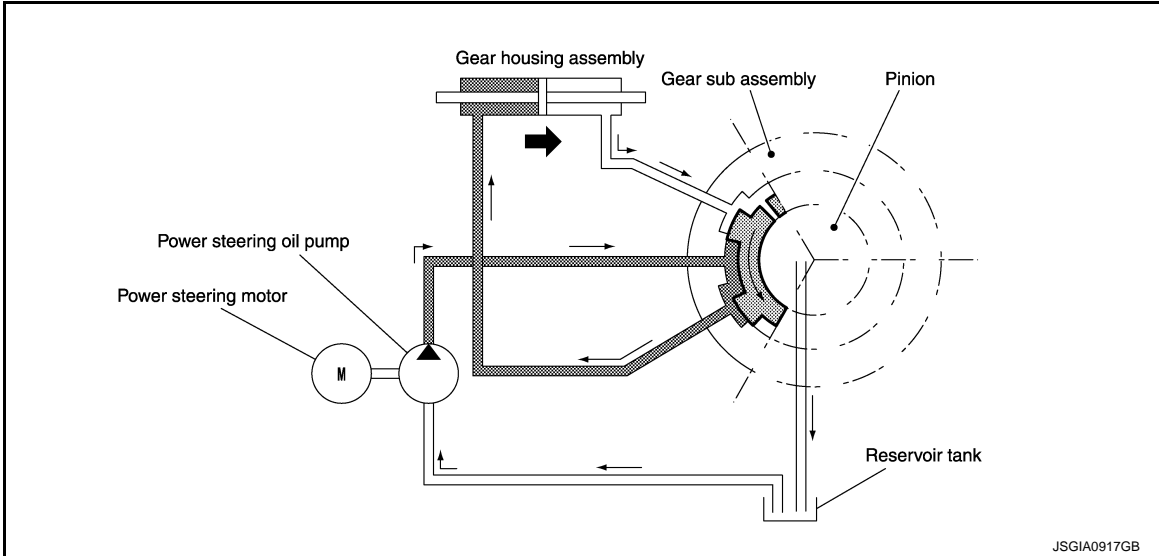

The hydraulic routes open from power steering pump to gear housing left side and from gear housing right side to reservoir tank, providing right direction assist force to the rack.

### CONDITIONS FOR HYDRAULIC PUMP ELECTRIC POWER STEERING WARNING LAMP ON

- When the hydraulic pump electric power steering system is operating and steering assist force is being generated, the hydraulic pump electric power steering warning lamp is OFF.
- When the hydraulic pump electric power steering system is stopped by the fail-safe or protective function and steering assist force is not being generated, the hydraulic pump electric power steering warning lamp turns ON to inform the driver that the system is in the manual steering state.

#### NOTE:

When the hydraulic pump electric power steering system turns ON according to the protection system, the cause is internal high temperature state of the hydraulic pump electric power steering system. By stopping the engine, internal temperature of the system decreases. After starting the engine, the system returns to the normal state and the hydraulic pump electric power steering system warning lamp turns OFF. (The system is not malfunctioning.) For information about the protective function, refer to [STC-9. "HYDRAULIC PUMP ELECTRIC POWER STEERING SYSTEM : Protection Function"](#).

- When the ignition switch is turned ON, this lamp turns ON for lamp check (system check). When the system is operating normally, the lamp turns OFF after the engine starts.

Condition	Hydraulic pump electric power steering warning lamp
Ignition switch ON. (Lamp check)	ON
After engine start (steering assist force is generated)	OFF
When steering assist is stopped	ON

### HYDRAULIC PUMP ELECTRIC POWER STEERING SYSTEM : Fail-safe INFOID:000000007492027

When an error occurs in the hydraulic pump electric power steering system, fail-safe brings the system to a halt (manual steering) or restricted (constant steering assist level) state. When the system is in a halt state, fail-safe turns ON the hydraulic pump electric power steering warning lamp to warn the driver that the hydraulic pump electric power steering system is in the manual steering state.

DTC	Fail-safe condition
C1143	Certain steering assist force
C1601	Manual steering state
C1606	Manual steering state
C1607	Certain steering assist force



# SYSTEM

## < SYSTEM DESCRIPTION >

DTC	Fail-safe condition
C1608	Manual steering state
U1000	Normal control <b>NOTE:</b> If the cause is in a different ECU, the state changes to fixed steering assist force.

## HYDRAULIC PUMP ELECTRIC POWER STEERING SYSTEM : Protection Function

INFOID:000000007492028

- When the steering wheel is operated repeatedly or turned all the way for a long period during parking or low speed driving, the function of the hydraulic pump electric power steering system becomes limited to prevent the system from overheating. If the steering wheel is operated further more, the hydraulic pump electric power steering system stops and the hydraulic pump electric power steering system warning lamp may be turned ON. In this case, the steering wheel operation temporarily becomes hard. This is not a malfunction. When the engine is turned OFF (ignition switch OFF) and steering operation is stopped for a while, the temperature of the hydraulic pump electric power steering system decreases and the steering operation returns to normal after restarting the engine.
- Then, the hydraulic pump electric power steering system warning lamp turns OFF. If the system is OFF under the protection state, the hydraulic pump electric power steering system warning lamp turns ON to warn that the system is in the manual steering state. (This is not a system malfunction.) In addition, the following DTC remains to distinguish from malfunction.

DTC	vehicle condition
C160A	The system temporarily enters the manual steering state. (This is not a hydraulic pump electric power steering system malfunction.)

A  
B  
C  
D  
E  
F  
STC  
H  
I  
J  
K  
L  
M  
N  
O  
P

# DIAGNOSIS SYSTEM (POWER STEERING CONTROL MODULE)

< SYSTEM DESCRIPTION >

## DIAGNOSIS SYSTEM (POWER STEERING CONTROL MODULE)

### CONSULT Function

INFOID:000000007492029

#### FUNCTION

CONSULT can display each diagnostic item using the diagnostic test modes shown as per the following.

Diagnostic test mode	Function
ECU identification	The part number stored in the control unit can be read.
Self Diagnostic Results	Self-diagnostic results and freeze frame data can be read and erased quickly*
Data monitor	Input/Output data in the power steering control module can be read.

\*: The following diagnosis information is erased by erasing.

#### ECU IDENTIFICATION

Displays the part number stored in the control unit.

#### SELF-DIAG RESULTS MODE

Refer to [STC-13, "DTC Index"](#).

When "CRNT" is displayed on self-diagnosis result.

- The system is presently malfunctioning.

When "PAST" is displayed on self-diagnosis result.

- System malfunction in the past is detected, but the system is presently normal.

#### DATA MONITOR MODE

Monitor item (Unit)	Remarks
BATTERY VOLT (V)	Displays the power supply voltage for power steering control module.
STR ANG SPD (deg/s)	Displays the steering angle speed based on the steering angle signal transmitted by CAN communications.
MOTOR CURRENT (A)	Displays the current value consumed by power steering control module.
MTR REV SPD COMM (rpm)	Displays the power steering motor speed command value.
MTR REV SPD (rpm)	Displays the power steering motor speed.
C/U TEMP (°C or °F)	Displays the temperature of the power steering control module.
C/U TEMP A (°C or °F)	Displays the temperature of the power steering control module.
MTR ASSIST (%)	Displays the current percentage of the allowable assist ratio power steering motor.
ESTM VHCL SPD (km/h or mph)	Displays the vehicle speed calculated by the power steering control module.
WARNING LAMP (On/Off)	Hydraulic pump electric power steering system warning lamp control status is displayed.
ENGINE STATUS (STOP/RUN/CRANK)	Engine speed is displayed from engine condition signal with CAN communication
VHCL SPD JUDGE (OK/NG)	Displays the receiving status of the vehicle speed signal transmitted by CAN communications.

# POWER STEERING CONTROL MODULE

< ECU DIAGNOSIS INFORMATION >

## ECU DIAGNOSIS INFORMATION

### POWER STEERING CONTROL MODULE

Reference Value

INFOID:000000007492030

#### VALUES ON THE DIAGNOSIS TOOL

Monitor item	Data monitor	
	Condition	Display value
BATTERY VOLT	Engine running	Battery voltage (V)
STR ANG SPD	The steering wheel is not steered.	Approx. 0.0 deg/s
	The steering wheel is steered.	Displays steering angle speed (deg/s)
MOTOR CURRENT	Engine running	Steering wheel: Not steering (There is no steering force)
		Steering wheel: Right or left turn
MTR REV SPD COMM	Engine running	Steering wheel: Not steering (There is no steering force)
		Steering wheel: Right or left turn
MTR REV SPD	Engine running	Steering wheel: Not steering (There is no steering force)
		Steering wheel: Right or left turn
C/U TEMP	Engine running	Displays temperature of inside of power steering control module (°C or °F)
		Displays temperature of inside of power steering control module (°C or °F)
MTR ASSIST	Engine running	100% <sup>*3</sup>
		0.00 km/h or mph
ESTM VHCL SPD	Vehicle stopped	Approximately equal to the indication on speedometer <sup>*4</sup> (inside of ±10%)
	While driving	
WARNING LAMP	Hydraulic pump electric power steering warning lamp: ON	On
	Hydraulic pump electric power steering warning lamp: OFF	Off
ENGINE STATUS	Engine not running	STOP
	Engine running	RUN
	Engine cranking	CRANK
VHCL SPD JUDGE	Vehicle speed signal can be received via CAN communication	OK
	Vehicle speed signal cannot be received via CAN communication	NG

\*1: The value changes according to load of power steering motor.

\*2: This is in close agreement with a motor speed command value. Although a quick steering operation may cause disagreement, this is not a malfunction.

\*3: Usually, 100% is displayed. An excessive steering operation gradually lowers the percentage. When left standing, the percentage returns to 100%.

\*4: This may not agree with the speedometer indication immediately after the ignition switch is turned ON. This is not a malfunction.

# POWER STEERING CONTROL MODULE

< ECU DIAGNOSIS INFORMATION >

## TERMINAL LAYOUT

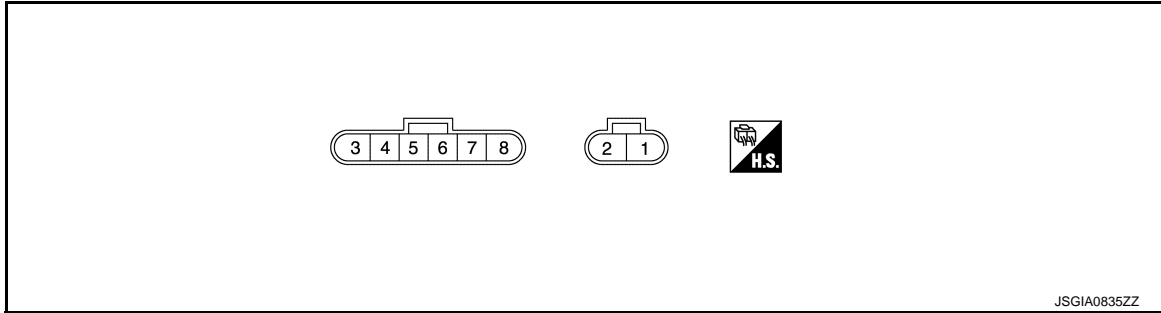

## PHYSICAL VALUES

Terminal No. (Wire Color)		Description		Condition	Value (Approx.)
+	-	Signal name	Input/Output		
1 (R)	Ground	Battery power supply	Input	Always	8.5 – 18.5 V
2 (B)	Ground	Ground	—	Always	0 V
5 (BR)	Ground	Ignition power supply	Input	Ignition switch: ON	8.5 – 18.5 V
				Ignition switch: OFF	0 V
7 (P)	—	CAN-L	Input/Output	—	—
8 (L)	—	CAN-H	Input/Output	—	—

## Fail-safe

INFOID:000000007492031

When an error occurs in the hydraulic pump electric power steering system, fail-safe brings the system to a halt (manual steering) or restricted (constant steering assist level) state. When the system is in a halt state, fail-safe turns ON the hydraulic pump electric power steering warning lamp to warn the driver that the hydraulic pump electric power steering system is in the manual steering state.

DTC	Fail-safe condition
C1143	Certain steering assist force
C1601	Manual steering state
C1606	Manual steering state
C1607	Certain steering assist force
C1608	Manual steering state
U1000	Normal control <b>NOTE:</b> If the cause is in a different ECU, the state changes to fixed steering assist force.

## Protection Function

INFOID:000000007492032

- When the steering wheel is operated repeatedly or turned all the way for a long period during parking or low speed driving, the function of the hydraulic pump electric power steering system becomes limited to prevent the system from overheating. If the steering wheel is operated further more, the hydraulic pump electric power steering system stops and the hydraulic pump electric power steering system warning lamp may be turned ON. In this case, the steering wheel operation temporarily becomes hard. This is not a malfunction. When the engine is turned OFF (ignition switch OFF) and steering operation is stopped for a while, the temperature of the hydraulic pump electric power steering system decreases and the steering operation returns to normal after restarting the engine.
- Then, the hydraulic pump electric power steering system warning lamp turns OFF. If the system is OFF under the protection state, the hydraulic pump electric power steering system warning lamp turns ON to

# POWER STEERING CONTROL MODULE

## < ECU DIAGNOSIS INFORMATION >

warn that the system is in the manual steering state. (This is not a system malfunction.) In addition, the following DTC remains to distinguish from malfunction.

DTC	vehicle condition
C160A	The system temporarily enters the manual steering state. (This is not a hydraulic pump electric power steering system malfunction.)

## DTC Inspection Priority Chart

INFOID:000000007492033

When multiple DTCs are detected simultaneously, check one by one depending on the following priority list.

Priority	Priority order item (DTC)
1	<ul style="list-style-type: none"> <li>• C1601 BATTERY VOLT</li> <li>• C1606 EPS MOTOR</li> <li>• C1608 CONTROL UNIT</li> </ul>
2	<ul style="list-style-type: none"> <li>• C1607 EEPROM</li> </ul>
3	<ul style="list-style-type: none"> <li>• C160A HEAT PROTECTION</li> </ul>
4	<ul style="list-style-type: none"> <li>• C1143 ST ANG SEN CIRCUIT</li> <li>• U1000 CAN COMM CIRCUIT</li> </ul>

## DTC Index

INFOID:000000007492034

STC

DTC	Items (CONSULT screen terms)	Reference
C1143	ST ANG SEN CIRCUIT	<a href="#">STC-18, "DTC Logic"</a>
C1601	BATTERY VOLT	<a href="#">STC-19, "DTC Logic"</a>
C1606	EPS MOTOR	<a href="#">STC-22, "DTC Logic"</a>
C1607	EEPROM	<a href="#">STC-23, "DTC Logic"</a>
C1608	CONTROL UNIT	<a href="#">STC-23, "DTC Logic"</a>
C160A	HEAT PROTECTION	<a href="#">STC-24, "DTC Logic"</a>
U1000	CAN COMM CIRCUIT	<a href="#">STC-25, "DTC Logic"</a>

### NOTE:

If two or more DTCs are detected, refer to [STC-13, "DTC Inspection Priority Chart"](#).



# DIAGNOSIS AND REPAIR WORK FLOW

< BASIC INSPECTION >

## BASIC INSPECTION

### DIAGNOSIS AND REPAIR WORK FLOW

#### Work Flow

INFOID:000000007492036

#### DETAILED FLOW

#### 1. INTERVIEW FROM THE CUSTOMER

Clarify customer complaints before inspection. First of all, perform an interview utilizing reproduce symptoms as well as fully understand it. Ask customer about his/her complaints carefully. Check symptoms by driving vehicle with customer, if necessary.

**CAUTION:**

**Customers are not professional. Never guess easily like “maybe the customer means that...,” or “maybe the customer mentions this symptom”.**

>> GO TO 2.

#### 2. CHECK SYMPTOM

Reproduce the symptom that is indicated by the customer, based on the information from the customer obtained by interview. Also check that the symptom is not caused by protection function. Refer to [STC-12. "Protection Function"](#).

**CAUTION:**

**When the symptom is caused by normal operation, fully inspect each portion and obtain the understanding of customer that the symptom is not caused by a malfunction.**

>> GO TO 3.

#### 3. CHECK VEHICLE CONDITION

**With CONSULT**

1. Turn ignition switch ON.
2. Check “C/U TEMP” and “C/U TEMP A” in “DATA MONITOR” in “EPS”.

Monitor item	Values
C/U TEMP	90°C (194°F) or less
C/U TEMP A	90°C (194°F) or less

Is the inspection result normal?

YES >> GO TO 4.

NO >> Wait with the ignition switch OFF until the data monitor indication becomes 90 °C (194 °F) or less. Go to 4 after the temperature drops to 90 °C (194 °F) or less.

#### 4. PERFORM SELF-DIAGNOSIS

**With CONSULT**

Perform self-diagnosis.

Is any DTC detected?

YES >> Record or print DTC and freeze frame data (FFD). GO TO 5.

NO >> GO TO 7.

#### 5. RECHECK SYMPTOM

**With CONSULT**

1. Erase self-diagnostic results for “EPS”.
2. Perform DTC confirmation procedures for the error detected system.

**NOTE:**

If some DTCs are detected at the same time, determine the order for performing the diagnosis based on [STC-13. "DTC Inspection Priority Chart"](#).

Is any DTC detected?





# DIAGNOSIS AND REPAIR WORK FLOW

< BASIC INSPECTION >

Interview sheet					
Customer name	MR/MS	Registration number		Initial year registration	
		Vehicle type		VIN	
Storage date		Engine		Mileage	km (Mile)
Operation conditions, etc.	<input type="checkbox"/> Irrelevant <input type="checkbox"/> When engine starts <input type="checkbox"/> During idling <input type="checkbox"/> During driving <input type="checkbox"/> During acceleration <input type="checkbox"/> At constant speed driving <input type="checkbox"/> During deceleration <input type="checkbox"/> During cornering (right curve or left curve) <input type="checkbox"/> During steering				
Other conditions					
Memo					

A  
B  
C  
D  
E  
F  
H  
I  
J  
K  
L  
M  
N  
O  
P

STC

# C1143 STEERING ANGLE SENSOR

< DTC/CIRCUIT DIAGNOSIS >

## DTC/CIRCUIT DIAGNOSIS

### C1143 STEERING ANGLE SENSOR

DTC Logic

INFOID:000000007492038

#### DTC DETECTION LOGIC

DTC	Display item	Malfunction detected condition	Possible cause
C1143	ST ANG SEN CIRCUIT	When a malfunction is detected in steering angle sensor.	<ul style="list-style-type: none"><li>• Harness or connector</li><li>• Steering angle sensor</li><li>• Power steering control module</li></ul>

#### DTC CONFIRMATION PROCEDURE

##### 1. PRECONDITIONING

If "DTC CONFIRMATION PROCEDURE" has been previously conducted, always turn ignition switch OFF and wait at least 10 seconds before conducting the next test.

>> GO TO 2.

##### 2. DTC REPRODUCTION PROCEDURE

###### With CONSULT

1. Turn the ignition switch OFF to ON.
2. Perform "EPS" self-diagnosis.

Is DTC "C1143" detected?

- YES >> Proceed to diagnosis procedure. Refer to [STC-18, "Diagnosis Procedure"](#).  
NO >> INSPECTION END

#### Diagnosis Procedure

INFOID:000000007492039

##### 1. CHECK STEERING ANGLE SENSOR CIRCUIT

Check steering angle sensor circuit. Refer to [BRC-77, "Diagnosis Procedure"](#).

Is the inspection result normal?

- YES >> GO TO 2.  
NO >> Repair or replace error-detected parts.

##### 2. CHECK TERMINALS AND HARNESS CONNECTORS

Check the power steering control module pin terminals for damage or loose connection with harness connector.

Is the inspection result normal?

- YES >> Power steering control module is malfunctioning. Replace power steering oil pump assembly. Refer to [ST-32, "Removal and Installation"](#).  
NO >> Repair or replace error-detected parts.

# C1601 BATTERY POWER SUPPLY

< DTC/CIRCUIT DIAGNOSIS >

## C1601 BATTERY POWER SUPPLY

### DTC Logic

INFOID:000000007492040

### DTC DETECTION LOGIC

DTC	Display item	Malfunction detected condition	Possible cause
C1601	BATTERY VOLT	When a power supply voltage to the power steering control module is maintained at 18.5 V or more or at less than 8.5 V continuously for 0.5 seconds or more.	<ul style="list-style-type: none"> <li>• Harness or connector</li> <li>• Power steering control module</li> <li>• Fuse</li> <li>• Battery power supply circuit</li> <li>• Battery</li> </ul>

### DTC CONFIRMATION PROCEDURE

#### 1. PRECONDITIONING

If "DTC CONFIRMATION PROCEDURE" has been previously conducted, always turn ignition switch OFF and wait at least 10 seconds before conducting the next test.

>> GO TO 2.

#### 2. DTC REPRODUCTION PROCEDURE

##### With CONSULT

1. Turn the ignition switch OFF to ON.
2. Perform "EPS" self-diagnosis.

Is DTC "C1601" detected?

- YES >> Proceed to diagnosis procedure. Refer to [STC-19, "Diagnosis Procedure"](#)  
 NO >> INSPECTION END

### Diagnosis Procedure

INFOID:000000007492041

#### 1. CHECK POWER STEERING CONTROL MODULE GROUND CIRCUIT

1. Turn ignition switch OFF.
2. Disconnect power steering control module harness connector.
3. Check continuity between power steering control module harness connector terminal and ground.

Power steering control module		—	Continuity
Connector	Terminal		
E33	2	Ground	Existed

Is the inspection result normal?

- YES >> GO TO 2.  
 NO >> Repair open circuit or short to ground or short to power in harness or connectors, and repair or replace error-detected parts.

#### 2. CHECK POWER STEERING CONTROL MODULE POWER SUPPLY CIRCUIT (1)

1. Check voltage between power steering control module harness connector terminals and ground.

Power steering control module		—	Voltage (Approx.)
Connector	Terminal		
E33	1	Ground	8.5 – 18.5 V

2. Turn ignition switch ON.  
**CAUTION:**  
**Never start the engine.**
3. Check voltage between power steering control module harness connector terminals and ground.

# C1601 BATTERY POWER SUPPLY

## < DTC/CIRCUIT DIAGNOSIS >

Power steering control module		—	Voltage (Approx.)
Connector	Terminal		
E33	1	Ground	8.5 – 18.5 V

Is the inspection result normal?

YES >> GO TO 4.

NO >> GO TO 3.

### 3. CHECK POWER STEERING CONTROL MODULE POWER SUPPLY CIRCUIT (2)

1. Turn ignition switch OFF.
2. Check the 100A fusible link (#D).
3. Disconnect battery terminal with fusible link harness connector.
4. Check continuity and short between power steering control module harness connector terminal and battery terminal with fusible link harness connector terminal.

Power steering control module		Battery terminal with fusible link		Continuity
Connector	Terminal	Connector	Terminal	
E33	1	E1	3	Existed

5. Check continuity between power steering control module harness connector terminal and ground.

Power steering control module		—	Continuity
Connector	Terminal		
E33	1	Ground	Not existed

Is the inspection result normal?

YES >> Perform the trouble diagnosis for battery power supply circuit. Refer to [PG-11, "Wiring Diagram - BATTERY POWER SUPPLY -"](#).

NO >> Repair or replace error-detected parts.

### 4. CHECK POWER STEERING CONTROL MODULE POWER SUPPLY CIRCUIT (3)

1. Check voltage between power steering control module harness connector terminals and ground.

Power steering control module		—	Voltage (Approx.)
Connector	Terminal		
E34	5	Ground	0 V

2. Turn ignition switch ON.  
**CAUTION:**  
**Never start the engine.**
3. Check voltage between power steering control module harness connector terminals and ground.

Power steering control module		—	Voltage (Approx.)
Connector	Terminal		
E34	5	Ground	8.5 – 18.5 V

Is the inspection result normal?

YES >> GO TO 6.

NO >> GO TO 5.

### 5. CHECK POWER STEERING CONTROL MODULE POWER SUPPLY CIRCUIT (4)

1. Turn ignition switch OFF.
2. Check the 10A fuse block (#3).
3. Check continuity and short between power steering control module harness connector terminal and fuse block harness connector terminal.

# C1601 BATTERY POWER SUPPLY

## < DTC/CIRCUIT DIAGNOSIS >

Power steering control module		Fuse block (J/B)		Continuity
Connector	Terminal	Connector	Terminal	
E34	5	E103	4F	Existed

4. Check continuity between power steering control module harness connector terminal and ground.

Power steering control module		—	Continuity
Connector	Terminal		
E34	5	Ground	Not existed

Is the inspection result normal?

YES >> Perform the trouble diagnosis for ignition power supply circuit. Refer to [PG-29, "Wiring Diagram - IGNITION POWER SUPPLY -"](#).

NO >> Repair or replace error-detected parts.

## 6. CHECK TERMINALS AND HARNESS CONNECTORS

Check the power steering control module pin terminals for damage or loose connection with harness connector.

Is the inspection result normal?

YES >> Power steering control module is malfunctioning. Replace steering oil pump assembly. Refer to [ST-32, "Removal and Installation"](#).

NO >> Repair or replace error-detected parts.

A  
B  
C  
D  
E  
F  
STC  
H  
I  
J  
K  
L  
M  
N  
O  
P

# C1606 EPS MOTOR

< DTC/CIRCUIT DIAGNOSIS >

## C1606 EPS MOTOR

### DTC Logic

INFOID:000000007492042

### DTC DETECTION LOGIC

DTC	Display item	Malfunction detected condition	Possible cause
C1606	EPS MOTOR	When the motor driver malfunction of power steering control module or power steering control module motor driver malfunction is detected.	<ul style="list-style-type: none"><li>• Harness or connector</li><li>• Power steering control motor</li><li>• Power steering control module</li></ul>

### DTC CONFIRMATION PROCEDURE

#### 1. PRECONDITIONING

If "DTC CONFIRMATION PROCEDURE" has been previously conducted, always turn ignition switch OFF and wait at least 10 seconds before conducting the next test.

>> GO TO 2.

#### 2. DTC REPRODUCTION PROCEDURE

##### With CONSULT

1. Turn the ignition switch OFF to ON.
2. Perform "EPS" self-diagnosis.

##### Is DTC "C1606" detected?

- YES >> Proceed to diagnosis procedure. Refer to [STC-22, "Diagnosis Procedure"](#).  
NO >> INSPECTION END

### Diagnosis Procedure

INFOID:000000007492043

#### 1. PERFORM SELF-DIAGNOSIS

##### With CONSULT

1. Turn the ignition switch OFF to ON.
2. Erase self-diagnostic results for "EPS".
3. Turn the ignition switch OFF and wait for at least 10 seconds.
4. Perform self-diagnosis for "EPS".

##### Is DTC "C1606" detected?

- YES >> Power steering motor is malfunctioning. Replace power steering oil pump assembly. Refer to [ST-32, "Removal and Installation"](#).  
NO >> Check pin terminal and connection of each harness connector for malfunctioning conditions.

# C1607, C1608 POWER STEERING CONTROL MODULE

< DTC/CIRCUIT DIAGNOSIS >

## C1607, C1608 POWER STEERING CONTROL MODULE

### DTC Logic

INFOID:000000007492044

### DTC DETECTION LOGIC

DTC	Display item	Malfunction detected condition	Possible cause
C1607	EEPROM	When the memory (EEPROM) system malfunction is detected in power steering control module.	Power steering control module
C1608	CONTROL UNIT	When the internal malfunction is detected in power steering control module.	

### DTC CONFIRMATION PROCEDURE

#### 1. PRECONDITIONING

If "DTC CONFIRMATION PROCEDURE" has been previously conducted, always turn ignition switch OFF and wait at least 10 seconds before conducting the next test.

>> GO TO 2.

#### 2. DTC REPRODUCTION PROCEDURE

##### With CONSULT

1. Turn the ignition switch OFF to ON.
2. Perform "EPS" self-diagnosis.

Is DTC "C1607" or "C1608" detected?

- YES >> Proceed to diagnosis procedure. Refer to [STC-23, "Diagnosis Procedure"](#).  
NO >> INSPECTION END

### Diagnosis Procedure

INFOID:000000007492045

#### 1. PERFORM SELF-DIAGNOSIS

##### With CONSULT

1. Turn the ignition switch OFF to ON.
2. Erase self-diagnostic results for "EPS".
3. Turn the ignition switch OFF and wait for at least 10 seconds.
4. Perform self-diagnosis for "EPS".

Is DTC "C1607" or "C1608" detected?

- YES >> Power steering control module is malfunctioning. Replace power steering oil pump assembly. Refer to [ST-32, "Removal and Installation"](#).  
NO >> Check pin terminal and connection of each harness connector for malfunctioning conditions.

# C160A HEAT PROTECTION

< DTC/CIRCUIT DIAGNOSIS >

## C160A HEAT PROTECTION

### DTC Logic

INFOID:000000007492046

### DTC DETECTION LOGIC

DTC	Display item	Malfunction detected condition	Possible cause
C160A	HEAT PROTECTION	When the steering wheel is operated excessively and the interior temperature of the power steering system reaches 118°C (244.4°F) or more. (Protection function) <b>NOTE:</b> Although the hydraulic pump electric power steering system warning lamp turns ON, this is not a system malfunction. The state returns to normal after stopping steering operation and waiting until the system interior temperature drops to 90°C (194°F) or less.	The protection of the hydraulic pump electric power steering system

### DTC CONFIRMATION PROCEDURE

#### 1. PRECONDITIONING

If "DTC CONFIRMATION PROCEDURE" has been previously conducted, always turn ignition switch OFF and wait at least 10 seconds before conducting the next test.

>> GO TO 2.

#### 2. DTC REPRODUCTION PROCEDURE

##### Ⓟ With CONSULT

1. Turn the ignition switch OFF to ON.
2. Perform "EPS" self-diagnosis.

Is DTC "C160A" detected?

- YES >> Go to [STC-15. "Work Flow"](#).  
NO >> INSPECTION END



# U1000 CAN COMM CIRCUIT

< DTC/CIRCUIT DIAGNOSIS >

## U1000 CAN COMM CIRCUIT

### Description

INFOID:000000007492047

CAN (Controller Area Network) is a serial communication line for real time application. It is an on-vehicle multiplex communication line with high data communication speed and excellent error detection ability. Many electronic control units are equipped onto a vehicle, and each control unit shares information and links with other control units during operation (not independent). In CAN communication, control units are connected with 2 communication lines (CAN-H line, CAN-L line) allowing a high rate of information transmission with less wiring. Each control unit communicate data but selectively reads required data only.

### DTC Logic

INFOID:000000007492048

### DTC DETECTION LOGIC

DTC	Display item	Malfunction detected condition	Possible cause
U1000	CAN COMM CIRCUIT	Power steering control module is not transmitting/receiving CAN communication signal for 2 seconds or more.	CAN communication error

### DTC CONFIRMATION PROCEDURE

#### 1. PRECONDITIONING

If "DTC CONFIRMATION PROCEDURE" has been previously conducted, always turn ignition switch OFF and wait at least 10 seconds before conducting the next test.

>> GO TO 2.

#### 2. DTC REPRODUCTION PROCEDURE

##### With CONSULT

1. Turn the ignition switch OFF to ON.
2. Perform "EPS" self-diagnosis.

Is DTC "U1000" detected?

- YES >> Go to [STC-25, "Diagnosis Procedure"](#).  
NO >> INSPECTION END

### Diagnosis Procedure

INFOID:000000007492049

Proceed to [LAN-17, "Trouble Diagnosis Flow Chart"](#).

A  
B  
C  
D  
E  
F  
STC  
H  
I  
J  
K  
L  
M  
N  
O  
P

# HYDRAULIC PUMP ELECTRIC POWER STEERING WARNING LAMP

< DTC/CIRCUIT DIAGNOSIS >

---

## HYDRAULIC PUMP ELECTRIC POWER STEERING WARNING LAMP

### Component Function Check

INFOID:000000007492050

#### 1. CHECK THE ILLUMINATION OF THE HYDRAULIC PUMP ELECTRIC POWER STEERING WARNING LAMP

Check that the hydraulic pump electric power steering warning lamp turns ON when ignition switch turns ON. Then, hydraulic pump electric power steering warning lamp turns OFF after the engine is started.

Is the inspection result normal?

YES >> INSPECTION END

NO >> Perform trouble diagnosis. Refer to [STC-26, "Diagnosis Procedure"](#).

### Diagnosis Procedure

INFOID:000000007492051

#### 1. PERFORM SELF-DIAGNOSIS

##### With CONSULT

1. Turn the ignition switch OFF to ON.
2. Perform "EPS" self-diagnosis.

Is any DTC detected?

YES >> Check the DTC. Refer to [STC-13, "DTC Index"](#).

NO >> GO TO 2.

#### 2. CHECK HYDRAULIC PUMP ELECTRIC POWER STEERING WARNING LAMP SIGNAL

##### With CONSULT

1. Turn the ignition switch ON.
2. Select in "WARNING LAMP" in "DATA MONITOR" in "EPS".
3. Check that the item in "DATA MONITOR" is "On".

**CAUTION:**

**Never start the engine.**

4. Start the engine.

**CAUTION:**

**Never drive the vehicle.**

5. Check that the item in "DATA MONITOR" is "Off".

Is the inspection result normal?

YES >> Perform the trouble diagnosis for combination meter power supply circuit. Refer to [MWI-63, "COMBINATION METER : Diagnosis Procedure"](#).

NO >> GO TO 3.

#### 3. CHECK TERMINALS AND HARNESS CONNECTORS

Check the power steering control module pin terminals for damage or loose connection with harness connector.

Is the inspection result normal?

YES >> Power steering control module is malfunctioning. Replace power steering oil pump assembly. Refer to [ST-32, "Removal and Installation"](#).

NO >> Repair or replace error-detected parts.

# HYDRAULIC PUMP ELECTRIC POWER STEERING WARNING LAMP DOES NOT TURN ON

< SYMPTOM DIAGNOSIS >

## SYMPTOM DIAGNOSIS

### HYDRAULIC PUMP ELECTRIC POWER STEERING WARNING LAMP DOES NOT TURN ON

#### Description

INFOID:000000007492052

The hydraulic pump electric power steering warning lamp does not illuminate when the ignition switch is turned ON (lamp check).

#### Diagnosis Procedure

INFOID:000000007492053

#### 1. CHECK THE HYDRAULIC PUMP ELECTRIC POWER STEERING WARNING LAMP

Perform trouble diagnosis for the hydraulic pump electric power steering warning lamp system. Refer to [STC-26. "Diagnosis Procedure"](#).

Is the inspection result normal?

- YES >> Check that the pin terminals and the connection of each connector are normal.
- NO >> Repair or replace error-detected parts.

A  
B  
C  
D  
E  
F  
H  
I  
J  
K  
L  
M  
N  
O  
P

STC

# HYDRAULIC PUMP ELECTRIC POWER STEERING WARNING LAMP DOES NOT TURN OFF

< SYMPTOM DIAGNOSIS >

## HYDRAULIC PUMP ELECTRIC POWER STEERING WARNING LAMP DOES NOT TURN OFF

### Description

INFOID:000000007492054

Hydraulic pump electric power steering warning lamp does not turn OFF several seconds after engine started

### Diagnosis Procedure

INFOID:000000007492055

#### 1. PERFORM SELF-DIAGNOSIS

##### With CONSULT

Perform "EPS" self-diagnosis.

Is any DTC detected?

YES >> Check the DTC. Refer to [STC-13, "DTC Index"](#).

NO >> GO TO 2.

#### 2. CHECK HYDRAULIC PUMP ELECTRIC POWER STEERING WARNING LAMP

Perform the trouble diagnosis of hydraulic pump electric power steering warning lamp. Refer to [STC-26, "Diagnosis Procedure"](#).

Is the inspection result normal?

YES >> GO TO 3.

NO >> Repair or replace error-detected parts.

#### 3. POWER STEERING CONTROL MODULE POWER SUPPLY AND GROUND CIRCUIT

Perform the trouble diagnosis of power steering control module power supply and ground. Refer to [STC-19, "Diagnosis Procedure"](#).

Is the inspection result normal?

YES >> Check that the pin terminals and the connection of each connector are normal.

NO >> Repair or replace error-detected parts.

# STEERING WHEEL TURNING FORCE IS HEAVY OR LIGHT

< SYMPTOM DIAGNOSIS >

## STEERING WHEEL TURNING FORCE IS HEAVY OR LIGHT

### Diagnosis Procedure

INFOID:000000007492056

#### 1. PERFORM SELF-DIAGNOSIS

##### With CONSULT

Perform "EPS" self-diagnosis.

Is a malfunctioning system displayed?

- YES >> Check malfunctioning system. Refer to [STC-13. "DTC Index"](#).
- NO >> GO TO 2.

#### 2. CHECK THE POWER STEERING CONTROL MODULE SIGNAL (1)

##### With CONSULT

1. Start the engine.

##### **CAUTION:**

**Never drive the vehicle.**

- 2. Turn the steering wheel until it stops.
- 3. Select "MTR ASSIST" in "DATA MONITOR" in "EPS".

Is the display value "100%"?

- YES >> GO TO 4.
- NO >> GO TO 3.

#### 3. CHECK THE POWER STEERING CONTROL MODULE SIGNAL (2)

##### With CONSULT

- 1. Select "C/U TEMP" and "C/U TEMP A" in "DATA MONITOR" in "EPS".
- 2. Stop the system until the DATA MONITOR display value drops to "90°C (194°F)" or less.
- 3. Check whether symptom continues.

Did symptom continue?

- YES >> GO TO 4.
- NO >> This occurs because the protection function lowers the assist force. It is not a system malfunction.  
INSPECTION END

#### 4. CHECK THE POWER STEERING CONTROL MODULE SIGNAL (3)

##### With CONSULT

- 1. Turn the steering wheel to the straight-ahead position. (There is no steering force)
- 2. Select "BATTERY VOLT" in "DATA MONITOR" in "EPS".

Is the display value "10.5 V" or more?

- YES >> GO TO 5.
- NO >> Check the battery power system. Refer to [STC-19. "Diagnosis Procedure"](#).

#### 5. CHECK THE POWER STEERING CONTROL MODULE SIGNAL (4)

##### With CONSULT

Select "ESTM VHCL SPD" in "DATA MONITOR" in "EPS".

Monitor item	Test condition	Display value
ESTM VHCL SPD	When stopped	0.00 km/h or mph
	While driving	Approximately equal to the indication on speedometer* (Inside of ±10%)

\*: This may not agree with the speedometer indication immediately after the ignition switch is turned ON. This is not a malfunction.

Is the check result normal?

- YES >> GO TO 6.
- NO >> Check the combination meter, ABS actuator and electric unit (control unit). Refer to [MWI-35. "CONSULT Function"](#) and [BRC-29. "CONSULT Function"](#).

# STEERING WHEEL TURNING FORCE IS HEAVY OR LIGHT

< SYMPTOM DIAGNOSIS >

## 6. CHECK THE POWER STEERING CONTROL MODULE SIGNAL (5)

### With CONSULT

Select "STR ANG SPD" in "DATA MONITOR" in "EPS".

Monitor item	Test condition	Display value
STR ANG SPD	The steering wheel is not steered.	Approx. 0.0 deg/s
	The steering wheel is steered.	Displays steering angle speed (deg/s)

Is the check result normal?

YES >> GO TO 7.

NO >> Check the steering angle sensor. Refer to [STC-18. "Diagnosis Procedure"](#).

## 7. CHECK THE POWER STEERING CONTROL MODULE SIGNAL (6)

### With CONSULT

Select "ENGINE STATUS" in "DATA MONITOR" in "EPS".

Is the display value "RUN"?

YES >> GO TO 8.

NO >> Check the ECM. Refer to [EC-66. "CONSULT Function"](#).

## 8. CHECK THE STEERING FORCE

Check the steering force. Refer to [ST-5. "Inspection"](#).

Is the check result normal?

YES >> INSPECTION END

NO >> It is possible that there is a mechanical malfunction. Check the steering system. Refer to [ST-29. "Inspection"](#).

# UNBALANCE STEERING WHEEL TURNING FORCE AND RETURN BETWEEN RIGHT AND LEFT

< SYMPTOM DIAGNOSIS >

## UNBALANCE STEERING WHEEL TURNING FORCE AND RETURN BETWEEN RIGHT AND LEFT

### Diagnosis Procedure

INFOID:000000007492057

#### 1.CHECK THE ILLUMINATION OF THE HYDRAULIC PUMP ELECTRIC POWER STEERING WARNING LAMP

Check the hydraulic pump electric power steering warning lamp while engine is running.

Does the hydraulic pump electric power steering warning lamp turn OFF?

YES >> GO TO 2.

NO >> Refer to [STC-28, "Diagnosis Procedure"](#).

#### 2.CHECK WHEEL ALIGNMENT

Check the wheel alignment. Refer to [FSU-6, "Inspection"](#).

Is the inspection result normal?

YES >> GO TO 3.

NO >> Adjustment of wheel alignment. Refer to [FSU-6, "Adjustment"](#).

#### 3.CHECK STEERING WHEEL TURNING FORCE

Check the steering wheel turning force. Refer to [ST-5, "Inspection"](#).

Is the inspection result normal?

YES >> INSPECTION END

NO >> Check the steering wheel turning force for mechanical malfunction. Refer to [ST-29, "Inspection"](#).

A  
B  
C  
D  
E  
F  
STC  
H  
I  
J  
K  
L  
M  
N  
O  
P

# UNBALANCE STEERING WHEEL TURNING FORCE (TORQUE VARIATION)

< SYMPTOM DIAGNOSIS >

## UNBALANCE STEERING WHEEL TURNING FORCE (TORQUE VARIATION)

### Diagnosis Procedure

INFOID:000000007492058

#### 1.PERFORM SELF-DIAGNOSIS

##### With CONSULT

Perform "EPS" self-diagnosis.

Is a malfunctioning system displayed?

YES >> Check malfunctioning system. Refer to [STC-13. "DTC Index"](#).

NO >> GO TO 2.

#### 2.CHECK THE POWER STEERING CONTROL MODULE SIGNAL (1)

##### With CONSULT

1. Start the engine.

##### **CAUTION:**

**Never drive the vehicle.**

2. Turn the steering wheel until it stops.

3. Select "MTR ASSIST" in "DATA MONITOR" in "EPS".

Is the display value "100%"?

YES >> GO TO 4.

NO >> GO TO 3.

#### 3.CHECK THE POWER STEERING CONTROL MODULE SIGNAL (2)

##### With CONSULT

1. Select "C/U TEMP" and "C/U TEMP A" in "DATA MONITOR" in "EPS".

2. Stop the system until the DATA MONITOR display value drops to "90°C (194°F)" or less.

3. Check whether symptom continues.

Did symptom continue?

YES >> GO TO 4.

NO >> This occurs because the protection function lowers the assist force. It is not a system malfunction.  
INSPECTION END

#### 4.CHECK THE POWER STEERING CONTROL MODULE SIGNAL (3)

##### With CONSULT

1. Turn the steering wheel to the straight-ahead position. (There is no steering force)

2. Select "BATTERY VOLT" in "DATA MONITOR" in "EPS".

Is the display value "10.5 V" or more?

YES >> GO TO 5.

NO >> Check the battery power system. Refer to [STC-19. "Diagnosis Procedure"](#).

#### 5.CHECK THE POWER STEERING CONTROL MODULE SIGNAL (4)

##### With CONSULT

Select in "ESTM VHCL SPD" in "DATA MONITOR" in "EPS".

Monitor item	Test condition	Display value
ESTM VHCL SPD	When stopped	0.00 km/h or mph
	While driving	Approximately equal to the indication on speedometer* (Inside of $\pm 10\%$ )

\*: This may not agree with the speedometer indication immediately after the ignition switch is turned ON. This is not a malfunction.

Is the check result normal?

YES >> GO TO 6.



# UNBALANCE STEERING WHEEL TURNING FORCE (TORQUE VARIATION)

## < SYMPTOM DIAGNOSIS >

NO >> Check the combination meter, ABS actuator and electric unit (control unit). Refer to [MWI-35, "CONSULT Function"](#) and [BRC-29, "CONSULT Function"](#).

### 6. CHECK THE POWER STEERING CONTROL MODULE SIGNAL (5)

#### With CONSULT

Select "STR ANG SPD" in "DATA MONITOR" in "EPS".

Monitor item	Test condition	Display value
STR ANG SPD	The steering wheel is not steered.	Approx. 0.0 deg/s
	The steering wheel is steered.	Displays steering angle speed (deg/s)

Is the check result normal?

YES >> GO TO 7.

NO >> Check the steering angle sensor. Refer to [STC-18, "Diagnosis Procedure"](#).

### 7. CHECK THE POWER STEERING CONTROL MODULE SIGNAL (6)

#### With CONSULT

Select "ENGINE STATUS" in "DATA MONITOR" in "EPS".

Is the display value "RUN"?

YES >> GO TO 8.

NO >> Check the ECM. Refer to [EC-66, "CONSULT Function"](#).

### 8. CHECK STEERING COLUMN AND STEERING GEAR

Check the steering column assembly and steering gear assembly.

- Steering column assembly. Refer to [ST-12, "Exploded View"](#).
- Steering gear assembly. Refer to [ST-19, "Exploded View"](#).

Is the inspection result normal?

YES >> GO TO 9.

NO >> Repair or replace error-detected parts.

### 9. CHECK STEERING WHEEL TURNING FORCE

Check the steering wheel turning force. Refer to [ST-5, "Inspection"](#).

Is the inspection result normal?

YES >> INSPECTION END

NO >> Check the steering wheel turning force for mechanical malfunction. Refer to [ST-29, "Inspection"](#).

A  
B  
C  
D  
E  
F  
STC  
H  
I  
J  
K  
L  
M  
N  
O  
P

# POWER STEERING CONTROL MODULE

< REMOVAL AND INSTALLATION >

---

## REMOVAL AND INSTALLATION

### POWER STEERING CONTROL MODULE

#### Removal and Installation

INFOID:000000007492059

**CAUTION:**

**Disconnect battery negative terminal before starting operations.**

Never remove power steering control module from steering oil pump assembly. When replacing power steering control module, replace steering oil pump assembly. Refer to [ST-12, "Removal and Installation"](#).