

A
B
C

WW

SECTION

WIPER & WASHER

CONTENTS

<p>PRECAUTION 3</p> <p>PRECAUTIONS 3</p> <p style="padding-left: 20px;">Precaution for Supplemental Restraint System (SRS) "AIR BAG" and "SEAT BELT PRE-TENSIONER"3</p> <p style="padding-left: 20px;">Precaution for Procedure without Cowl Top Cover.....3</p> <p>PREPARATION 4</p> <p>PREPARATION 4</p> <p style="padding-left: 20px;">Commercial Service Tool4</p> <p>SYSTEM DESCRIPTION 5</p> <p>COMPONENT PARTS 5</p> <p style="padding-left: 20px;">Component Parts Location5</p> <p>SYSTEM 7</p> <p>FRONT WIPER AND WASHER SYSTEM7</p> <p style="padding-left: 20px;">FRONT WIPER AND WASHER SYSTEM : System Description7</p> <p style="padding-left: 20px;">FRONT WIPER AND WASHER SYSTEM : Circuit Diagram 10</p> <p style="padding-left: 20px;">FRONT WIPER AND WASHER SYSTEM : Fail-Safe 10</p> <p>REAR WIPER AND WASHER SYSTEM 11</p> <p style="padding-left: 20px;">REAR WIPER AND WASHER SYSTEM : System Description 11</p> <p style="padding-left: 20px;">REAR WIPER AND WASHER SYSTEM : Circuit Diagram 13</p> <p style="padding-left: 20px;">REAR WIPER AND WASHER SYSTEM : Fail-safe 13</p> <p>DIAGNOSIS SYSTEM (BCM) 15</p> <p>COMMON ITEM 15</p> <p style="padding-left: 20px;">COMMON ITEM : CONSULT Function (BCM - COMMON ITEM) 15</p> <p>WIPER 16</p>	<p style="padding-left: 20px;">WIPER : CONSULT Function (BCM - WIPER)17</p> <p>DIAGNOSIS SYSTEM (IPDM E/R) 19</p> <p style="padding-left: 20px;">Diagnosis Description 19</p> <p style="padding-left: 20px;">CONSULT Function (IPDM E/R) 21</p> <p>ECU DIAGNOSIS INFORMATION 24</p> <p>BCM, IPDM E/R 24</p> <p style="padding-left: 20px;">List of ECU Reference 24</p> <p>WIRING DIAGRAM 25</p> <p>WIPER AND WASHER SYSTEM 25</p> <p style="padding-left: 20px;">Wiring Diagram 25</p> <p>BASIC INSPECTION 27</p> <p>DIAGNOSIS AND REPAIR WORK FLOW 27</p> <p style="padding-left: 20px;">Work Flow 27</p> <p>DTC/CIRCUIT DIAGNOSIS 30</p> <p>FRONT WIPER MOTOR LO CIRCUIT 30</p> <p style="padding-left: 20px;">Component Function Check 30</p> <p style="padding-left: 20px;">Diagnosis Procedure 30</p> <p>FRONT WIPER MOTOR HI CIRCUIT 31</p> <p style="padding-left: 20px;">Component Function Check 31</p> <p style="padding-left: 20px;">Diagnosis Procedure 31</p> <p>FRONT WIPER STOP POSITION SIGNAL CIRCUIT 32</p> <p style="padding-left: 20px;">Component Function Check 32</p> <p style="padding-left: 20px;">Diagnosis Procedure 32</p> <p>FRONT WIPER MOTOR GROUND CIRCUIT ... 33</p> <p style="padding-left: 20px;">Diagnosis Procedure 33</p> <p>WASHER SWITCH 34</p> <p style="padding-left: 20px;">Component Inspection 34</p> <p>REAR WIPER MOTOR CIRCUIT 35</p>
--	--

A
B
C
D
E
F
G
H
I
J
K
WW
M
N
O
P



Component Function Check	35	REAR WIPER	48
Diagnosis Procedure	35	Exploded View	48
REAR WIPER STOP POSITION SIGNAL CIR- CUIT	37	WIPER ARM	48
Component Function Check	37	WIPER ARM : Removal and Installation	48
Diagnosis Procedure	37	WIPER ARM : Adjustment	49
SYMPTOM DIAGNOSIS	38	WIPER BLADE	49
WIPER AND WASHER SYSTEM SYMPTOMS	38	WIPER BLADE : Removal and Installation	50
Symptom Table	38	WIPER REFILL	50
NORMAL OPERATING CONDITION	40	WIPER REFILL : Removal and Installation	50
Description	40	WIPER MOTOR	50
FRONT WIPER DOES NOT OPERATE	41	WIPER MOTOR : Removal and Installation	50
Description	41	WASHER TANK	52
Diagnosis Procedure	41	Exploded View	52
REMOVAL AND INSTALLATION	43	Removal and Installation	52
FRONT WIPER	43	WASHER PUMP	54
Exploded View	43	Exploded View	54
WIPER ARM	44	Removal and Installation	54
WIPER ARM : Removal and Installation	44	WASHER NOZZLE & TUBE	56
WIPER ARM : Adjustment	45	Exploded View	56
WIPER BLADE	45	Hydraulic Layout	58
WIPER BLADE : Removal and Installation	45	WASHER NOZZLE	58
WIPER REFILL	46	WASHER NOZZLE : Removal and Installation	58
WIPER REFILL : Removal and Installation	46	WASHER NOZZLE : Inspection and Adjustment ...	59
WIPER DRIVE ASSEMBLY	46	WASHER TUBE	61
WIPER DRIVE ASSEMBLY : Removal and Instal- lation	46	WASHER TUBE : Removal and Installation	61
WIPER DRIVE ASSEMBLY : Disassembly and Assembly	47	WASHER LEVEL SWITCH	64
		Removal and Installation	64
		WIPER AND WASHER SWITCH	65
		Exploded View	65

PRECAUTIONS

< PRECAUTION >

PRECAUTION

PRECAUTIONS

Precaution for Supplemental Restraint System (SRS) "AIR BAG" and "SEAT BELT PRE-TENSIONER"

INFOID:000000008377981

The Supplemental Restraint System such as "AIR BAG" and "SEAT BELT PRE-TENSIONER", used along with a front seat belt, helps to reduce the risk or severity of injury to the driver and front passenger for certain types of collision. This system includes seat belt switch inputs and dual stage front air bag modules. The SRS system uses the seat belt switches to determine the front air bag deployment, and may only deploy one front air bag, depending on the severity of a collision and whether the front occupants are belted or unbelted. Information necessary to service the system safely is included in the "SRS AIR BAG" and "SEAT BELT" of this Service Manual.

WARNING:

Always observe the following items for preventing accidental activation.

- To avoid rendering the SRS inoperative, which could increase the risk of personal injury or death in the event of a collision that would result in air bag inflation, all maintenance must be performed by an authorized NISSAN/INFINITI dealer.
- Improper maintenance, including incorrect removal and installation of the SRS, can lead to personal injury caused by unintentional activation of the system. For removal of Spiral Cable and Air Bag Module, see "SRS AIR BAG".
- Never use electrical test equipment on any circuit related to the SRS unless instructed to in this Service Manual. SRS wiring harnesses can be identified by yellow and/or orange harnesses or harness connectors.

PRECAUTIONS WHEN USING POWER TOOLS (AIR OR ELECTRIC) AND HAMMERS

WARNING:

Always observe the following items for preventing accidental activation.

- When working near the Air Bag Diagnosis Sensor Unit or other Air Bag System sensors with the ignition ON or engine running, never use air or electric power tools or strike near the sensor(s) with a hammer. Heavy vibration could activate the sensor(s) and deploy the air bag(s), possibly causing serious injury.
- When using air or electric power tools or hammers, always switch the ignition OFF, disconnect the battery, and wait at least 3 minutes before performing any service.

Precaution for Procedure without Cowl Top Cover

INFOID:000000008377982

When performing the procedure after removing cowl top cover, cover the lower end of windshield with urethane, etc to prevent damage to windshield.

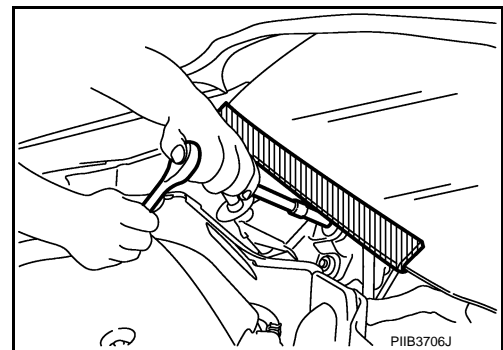

PREPARATION

< PREPARATION >

PREPARATION

PREPARATION

Commercial Service Tool

INFOID:000000008377983

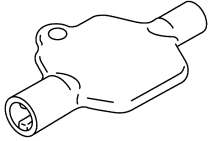
Tool name	Description
<p data-bbox="191 516 431 543">Washer nozzle adjuster</p>  <p data-bbox="776 632 859 646">JSLIA0149ZZ</p>	<p data-bbox="927 449 1425 531">Adjusting washer nozzle. (Available in SEC. 289 of PARTS CATALOG: Part No. 28949 1EA0A)</p> <p data-bbox="927 533 1425 611">NOTE: Washer nozzle adjuster is included with shipment of nozzle.</p>

COMPONENT PARTS

< SYSTEM DESCRIPTION >

SYSTEM DESCRIPTION

COMPONENT PARTS

Component Parts Location

INFOID:000000008377984

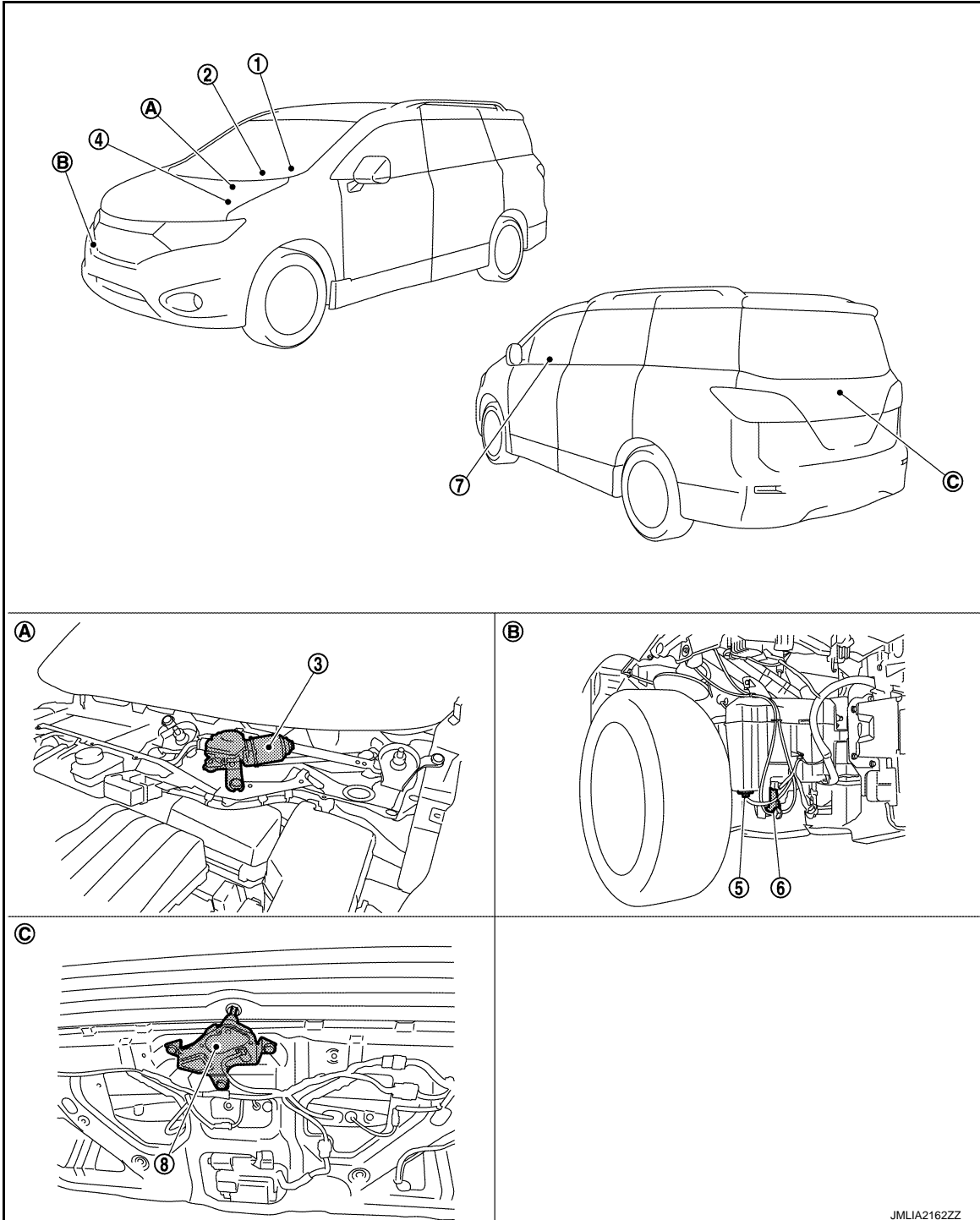

- A. Cowl top, left side of engine room B. Behind front bumper (RH) C. Back door finisher inside

A
B
C
D
E
F
G
H
I
J
K
M
N
O
P

WW

COMPONENT PARTS

< SYSTEM DESCRIPTION >

No.	Part	Function
1.	Combination meter	Transmits the vehicle speed signal to BCM via CAN communication.
2.	Combination switch (Wiper & washer switch)	Refer to BCS-8, "COMBINATION SWITCH READING SYSTEM : System Description" for detailed installation location.
3.	Front wiper motor	<ul style="list-style-type: none"> • IPDM E/R controls front wiper operation. • Front wiper stop position signal is transmitted to IPDM E/R.
4.	IPDM E/R	<ul style="list-style-type: none"> • Controls the integrated relay according to the request (via CAN communication) from BCM. • Performs the auto stop control of the front wiper. • Refer to PCS-4, "IPDM E/R : Component Parts Location" for detailed installation location.
5.	Washer level switch	<ul style="list-style-type: none"> • Combination meter indicates low washer fluid warning judged by the signal from the washer level switch. • Refer to MWI-17, "MASTER WARNING LAMP : System Description".
6.	Washer pump	<ul style="list-style-type: none"> • Washer fluid is sprayed according to washer switch states. • Switching between front washer and rear washer is performed according to the voltage polarity change to washer pump.
7.	BCM	<ul style="list-style-type: none"> • Judges the each switch status by the combination switch reading function. • Requests (via CAN communication) the front wiper relay and the front wiper high relay ON to IPDM E/R. • Supplies power to the rear wiper motor. • Performs the auto stop control of the rear wiper. • Refer to BCS-4, "BODY CONTROL SYSTEM : Component Parts Location" for detailed installation location.
8.	Rear wiper motor	<ul style="list-style-type: none"> • BCM controls rear wiper operation. • Rear wiper stop position signal is transmitted to BCM.

SYSTEM

< SYSTEM DESCRIPTION >

SYSTEM

FRONT WIPER AND WASHER SYSTEM

FRONT WIPER AND WASHER SYSTEM : System Description

INFOID:000000008377985

SYSTEM DIAGRAM

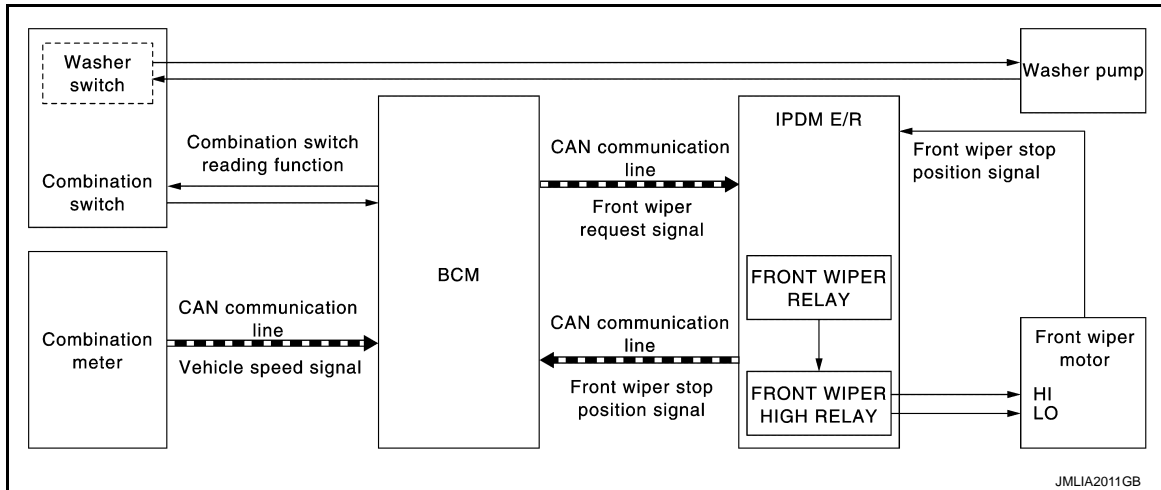

OUTLINE

The front wiper is controlled by each function of BCM and IPDM E/R.

Control by BCM

- Combination switch reading function
- Front wiper control function

Control by IPDM E/R

- Front wiper control function
- Relay control function

Combination meter indicates low washer fluid level warning judged by the signal from the washer level switch. For details of low washer fluid level warning, refer to [MWI-17, "MASTER WARNING LAMP : System Description"](#).

FRONT WIPER BASIC OPERATION

- BCM detects the combination switch condition by the combination switch reading function.
- BCM transmits the front wiper request signal to IPDM E/R via CAN communication depending on each operating condition of the front wiper.
- IPDM E/R turns ON/OFF the integrated front wiper relay and the front wiper high relay according to the front wiper request signal. IPDM E/R provides the power supply to operate the front wiper HI/LO operation.

FRONT WIPER LO OPERATION

- BCM transmits the front wiper request signal (LO) to IPDM E/R via CAN communication according to the front wiper LO operating condition.

Front wiper LO operating condition

- Ignition switch ON
- Front wiper switch LO or front wiper switch MIST (while pressing)
- IPDM E/R turns ON the integrated front wiper relay according to the front wiper request signal (LO).

FRONT WIPER HI OPERATION

- BCM transmits the front wiper request signal (HI) to IPDM E/R via CAN communication according to the front wiper HI operating condition.

Front wiper HI operating condition

- Ignition switch ON
- Front wiper switch HI
- IPDM E/R turns ON the integrated front wiper relay and the front wiper high relay according to the front wiper request signal (HI).

SYSTEM

< SYSTEM DESCRIPTION >

FRONT WIPER INT OPERATION

- BCM transmits the front wiper request signal (INT) to IPDM E/R via CAN communication depending on the front wiper INT operating condition and intermittent operation delay interval according to the wiper intermittent dial position.

Front wiper INT operating condition

- Ignition switch ON
- Front wiper switch INT
- IPDM E/R turns ON the integrated front wiper relay so that the front wiper is operated only once according to the front wiper request signal (INT).
- BCM detects stop position/except stop position of the front wiper motor according to the front wiper stop position signal received from IPDM E/R via CAN communication.
- BCM transmits the front wiper request signal (INT) again after the intermittent operation delay interval.

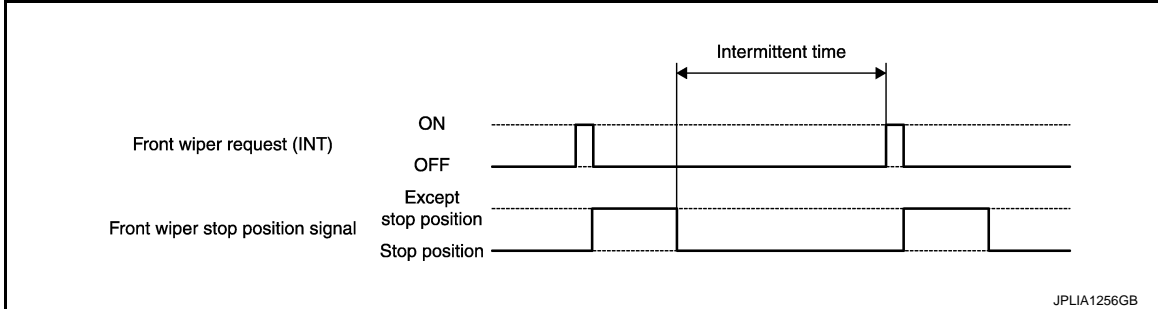

NOTE:

Factory setting of the front wiper intermittent operation is operation linked without vehicle speed. Front wiper intermittent operation can be set to operation linked or not linked with vehicle speed using CONSULT. Refer to [WW-17. "WIPER : CONSULT Function \(BCM - WIPER\)"](#).

Front wiper intermittent operation with vehicle speed

- BCM calculates the intermittent operation delay interval from the following
 - Vehicle speed signal
 - Wiper intermittent dial position

Unit: Second

Wiper intermittent dial position	Intermittent operation interval	Intermittent operation delay Interval		
		Vehicle speed		
		0 – 5 km/h (0 – 3.1 MPH)	5 – 65 km/h (3.1 – 40.4 MPH)*	65 km/h (40.4 MPH) or more
1	Short ↑	1	0.4	0.24
2		2.5	1	0.6
3		5	2	1.2
4		7.5	3	1.8
5		12.5	5	3
6	Long ↓	25	10	6
7		40	16	9.6

*: When operation setting is not linked with vehicle speed.

FRONT WIPER AUTO STOP OPERATION

- BCM stops transmitting the front wiper request signal when the front wiper switch is turned OFF.
- IPDM E/R detects the front wiper stop position signal from the front wiper motor and detects the front wiper motor position (stop position/except stop position).

SYSTEM

< SYSTEM DESCRIPTION >

- When the front wiper request signal is stopped, IPDM E/R turns ON the front wiper relay until the front wiper motor returns to the stop position.

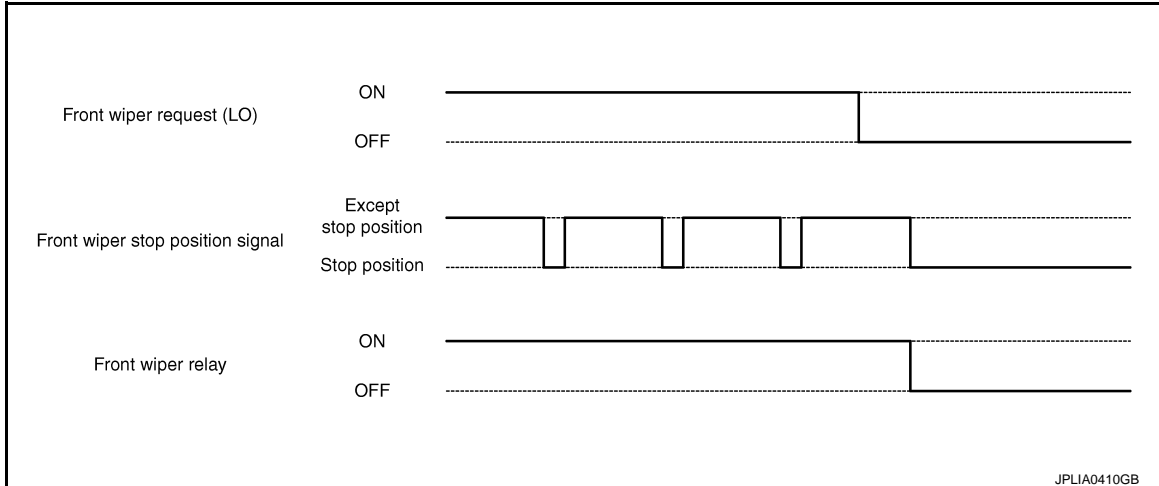

NOTE:

- BCM stops the transmitting of the front wiper request signal when the ignition switch is OFF.
- IPDM E/R turns the front wiper relay OFF when the ignition switch is OFF.

FRONT WIPER OPERATION LINKED WITH WASHER

- BCM transmits the front wiper request signal (LO) to IPDM E/R via CAN communication according to the washer linked operating condition of the front wiper.
- BCM transmits the front wiper request signal (LO) so that the front wiper operates approximately 2 times when the front washer switch OFF is detected.

Washer linked operating condition of front wiper

- Ignition switch ON
- Front washer switch ON (0.4 second or more)
- IPDM E/R turns ON the integrated front wiper relay according to the front wiper request signal (LO).
- The washer pump is grounded through the combination switch with the front washer switch ON.

WIPER LINKED AUTO LIGHTING FUNCTION

When light switch is in the AUTO position, front wiper operates, and then headlamp illuminates. Refer to [EXL-13. "AUTO LIGHT SYSTEM \(EXCEPT FOR CANADA\) : System Description"](#).

A
B
C
D
E
F
G
H
I
J
K

WW

M
N
O
P

SYSTEM

< SYSTEM DESCRIPTION >

FRONT WIPER AND WASHER SYSTEM : Circuit Diagram

INFOID:000000008377986

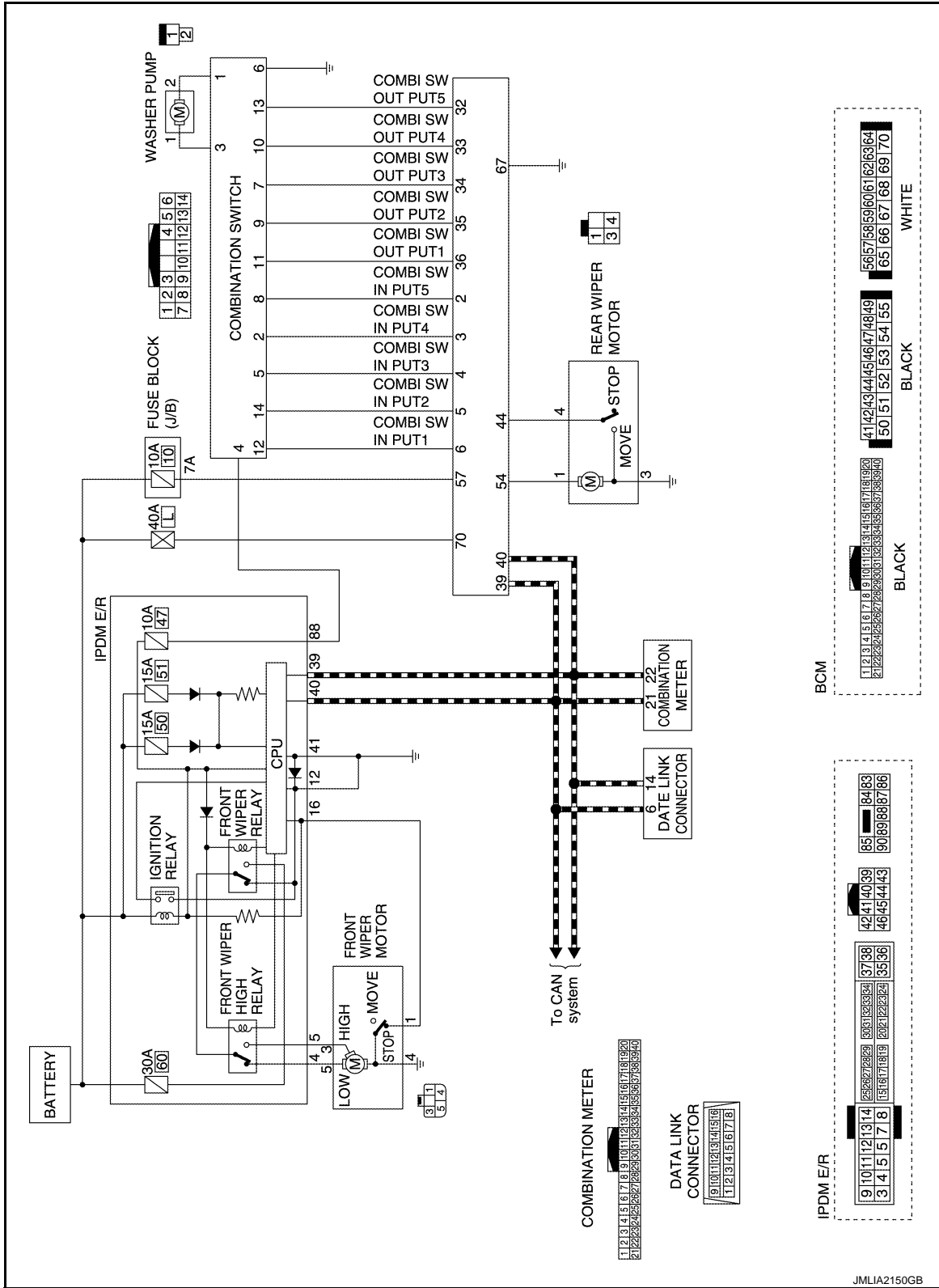

FRONT WIPER AND WASHER SYSTEM : Fail-Safe

INFOID:000000008377987

CAN COMMUNICATION CONTROL

When CAN communication with ECM and BCM is impossible, IPDM E/R performs fail-safe control. After CAN communication recovers normally, it also returns to normal control.

If No CAN Communication Is Available With BCM

SYSTEM

< SYSTEM DESCRIPTION >

Control part	Fail-safe operation
Front wiper motor	<ul style="list-style-type: none"> The status just before activation of fail-safe control is maintained until the ignition switch is turned OFF while the front wiper is operating at LO or HI speed. The wiper is operated at LO speed until the ignition switch is turned OFF if the fail-safe control is activated while the front wiper is set in the INT mode and the front wiper motor is operating. Returns automatically wiper to stop position when ignition switch is turned ON if fail-safe control is activated while front wiper motor is operated and wiper stop in the other position than stop position.

FRONT WIPER PROTECTION FUNCTION

IPDM E/R detects front wiper stop position by a front wiper stop position signal.

When a front wiper stop position signal is in the conditions listed below, IPDM E/R stops power supply to wiper after repeating a front wiper 10 seconds activation and 20 seconds stop.

Ignition switch	Front wiper switch	Front wiper stop position signal
ON	OFF	The front wiper stop position signal (stop position) cannot be input for 10 seconds.
	ON	The front wiper stop position signal does not change for 10 seconds.

NOTE:

This operation status can be confirmed on the IPDM E/R “Data Monitor” that displays “BLOCK” for the item “WIP PROT” while the wiper is stopped.

REAR WIPER AND WASHER SYSTEM

REAR WIPER AND WASHER SYSTEM : System Description

INFOID:000000008377988

SYSTEM DIAGRAM

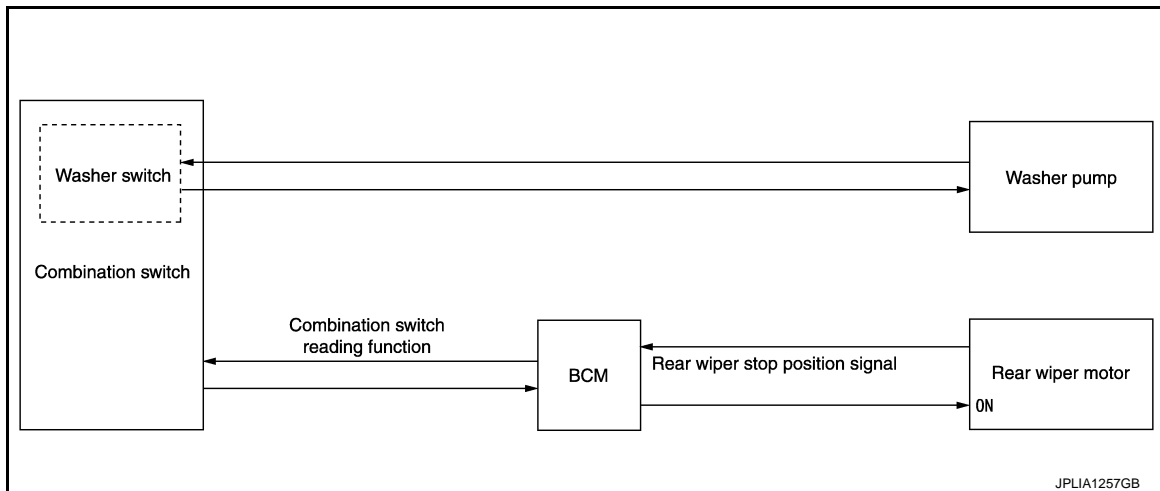

OUTLINE

The rear wiper is controlled by each function of BCM.

Control by BCM

- Combination switch reading function
- Rear wiper control function

REAR WIPER BASIC OPERATION

- BCM detects the combination switch condition by the combination switch reading function.
- BCM controls the rear wiper to start or stop.

REAR WIPER ON OPERATION

- BCM supplies power to the rear wiper motor according to the rear wiper ON operating condition.

Rear wiper ON operating condition

- Ignition switch ON
- Rear wiper switch ON

REAR WIPER INT OPERATION

SYSTEM

< SYSTEM DESCRIPTION >

- BCM supplies power to the rear wiper motor according to the INT operating condition.

Rear wiper INT operating condition

- Ignition switch ON
- Rear wiper switch INT
- BCM controls the rear wiper to operate once.
- BCM detects the rear wiper motor stopping position.
- BCM supplies power to the rear wiper motor after an intermittent from the stop of the rear wiper motor.

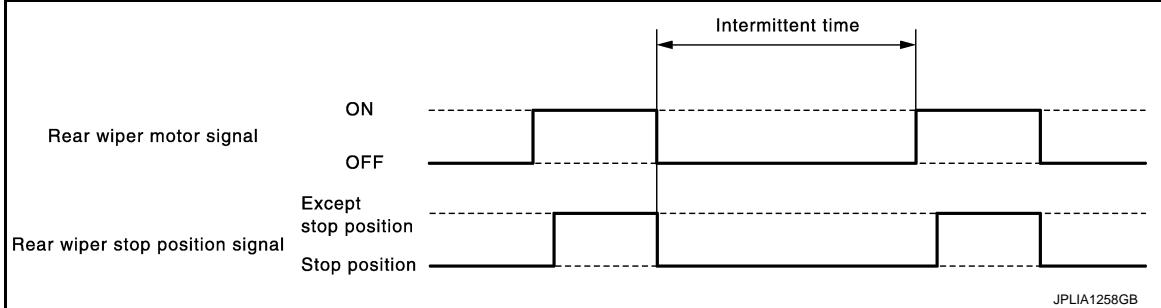

REAR WIPER AUTO STOP OPERATION

- BCM stops supplying power to the rear wiper motor when the rear wiper switch is turned OFF.
- BCM reads a rear wiper stop position signal from the rear wiper motor to detect a rear wiper motor position.
- When the rear wiper motor is at other than the stopping position, BCM continues to supply power to the rear wiper motor until it returns to the stopping position.

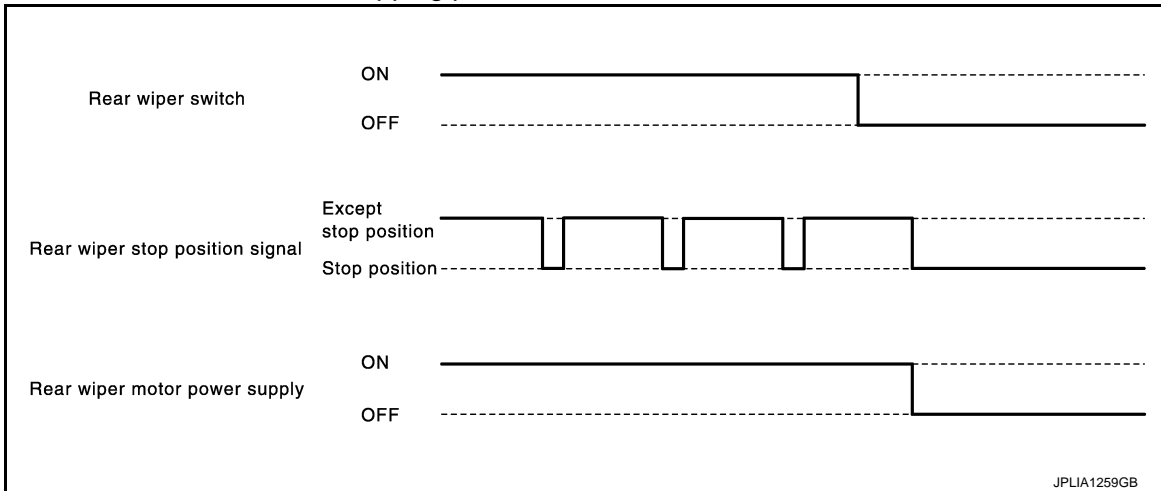

NOTE:

BCM stops supplying power to the rear wiper motor when the ignition switch is turned OFF.

REAR WIPER OPERATION LINKED WITH WASHER

- BCM supplies power to the rear wiper motor according to the washer linked operating condition of rear wiper. When the rear washer switch is turned OFF, BCM controls rear wiper to operate approximately 3 times.

Washer linked operating condition of rear wiper

- Ignition switch ON
- Rear washer switch ON (0.4 second or more)
- The washer pump is grounded through the combination switch with the rear washer switch ON.

SYSTEM

< SYSTEM DESCRIPTION >

REAR WIPER AND WASHER SYSTEM : Circuit Diagram

INFOID:000000008377989

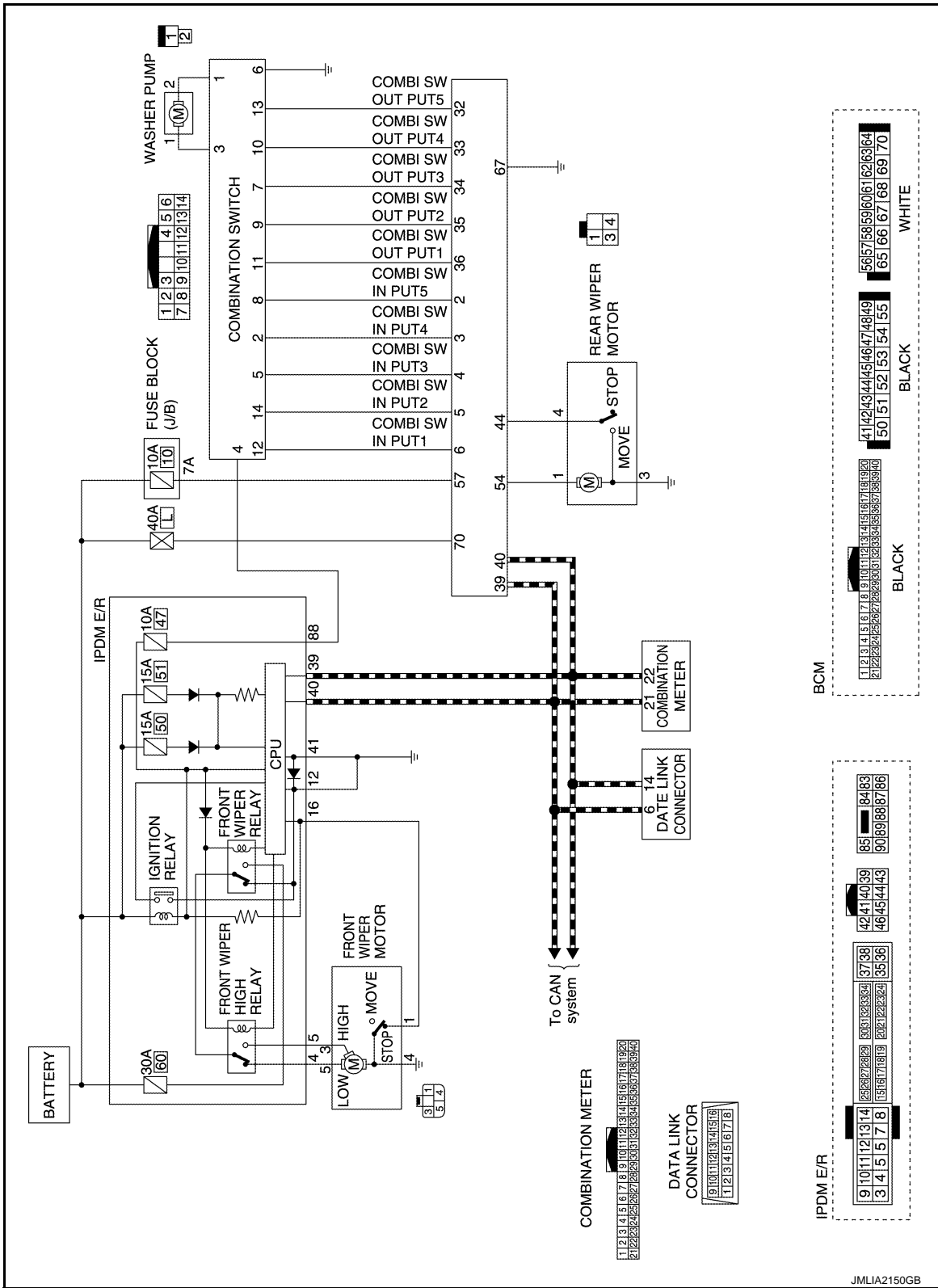

REAR WIPER AND WASHER SYSTEM : Fail-safe

INFOID:000000008377990

REAR WIPER MOTOR PROTECTION

BCM detects the rear wiper stopping position according to the rear wiper stop position signal. When the rear wiper stop position signal does not change for more than 5 seconds while driving the rear wiper, BCM stops power supply to protect the rear wiper motor.

SYSTEM

< SYSTEM DESCRIPTION >

Condition of cancellation

1. More than 1 minute is passed after the rear wiper stop.
2. Turn rear wiper switch OFF.
3. Operate the rear wiper switch or rear washer switch.

DIAGNOSIS SYSTEM (BCM)

< SYSTEM DESCRIPTION >

DIAGNOSIS SYSTEM (BCM)

COMMON ITEM

COMMON ITEM : CONSULT Function (BCM - COMMON ITEM)

INFOID:000000008843605

APPLICATION ITEM

CONSULT performs the following functions via CAN communication with BCM.

Diagnosis mode	Function Description
Work Support	Changes the setting for each system function.
Self Diagnostic Result	Displays the diagnosis results judged by BCM.
CAN Diag Support Monitor	Monitors the reception status of CAN communication viewed from BCM.
Data Monitor	The BCM input/output signals are displayed.
Active Test	The signals used to activate each device are forcibly supplied from BCM.
Ecu Identification	The BCM part number is displayed.
Configuration	<ul style="list-style-type: none"> Read and save the vehicle specification. Write the vehicle specification when replacing BCM.

SYSTEM APPLICATION

BCM can perform the following functions for each system.

NOTE:

It can perform the diagnosis modes except the following for all sub system selection items.

x: Applicable item

System	Sub system selection item	Diagnosis mode		
		Work Support	Data Monitor	Active Test
Door lock	DOOR LOCK	x	x	x
Rear window defogger	REAR DEFOGGER		x	x
Warning chime	BUZZER		x	x
Interior room lamp control system	INT LAMP	x	x	x
Exterior lamp	HEAD LAMP	x	x	x
Wiper and washer	WIPER	x	x	x
Turn signal and hazard warning lamps	FLASHER	x	x	x
Air conditioning control system	AIR CONDITONER		x	x*
<ul style="list-style-type: none"> Intelligent Key system Engine start system 	INTELLIGENT KEY	x	x	x
Combination switch	COMB SW		x	
Body control system	BCM	x		
NVIS	IMMU	x	x	x
Interior room lamp battery saver	BATTERY SAVER	x	x	x
Back door open	TRUNK		x	
Vehicle security system	THEFT ALM	x	x	x
RAP system	RETAINED PWR		x	
Signal buffer system	SIGNAL BUFFER		x	x
TPMS	AIR PRESSURE MONITOR	x	x	x

NOTE:

*: For models with automatic air conditioning control system, this diagnosis mode is not used.

FREEZE FRAME DATA (FFD)

The BCM records the following vehicle condition at the time a particular DTC is detected, and displays on CONSULT.

DIAGNOSIS SYSTEM (BCM)

< SYSTEM DESCRIPTION >

CONSULT screen item	Indication/Unit	Description	
Vehicle Speed	km/h	Vehicle speed of the moment a particular DTC is detected	
Odo/Trip Meter	km	Total mileage (Odometer value) of the moment a particular DTC is detected	
Vehicle Condition	SLEEP>LOCK	Power position status of the moment a particular DTC is detected*	While turning BCM status from low power consumption mode to normal mode [Power supply position is OFF (LOCK)]
	SLEEP>OFF		While turning BCM status from low power consumption mode to normal mode [Power supply position is OFF (OFF)]
	LOCK>ACC		While turning power supply position from OFF (LOCK) to ACC
	ACC>ON		While turning power supply position from ACC to ON
	RUN>ACC		While turning power supply position from RUN to ACC (Except emergency stop operation)
	CRANK>RUN		While turning power supply position from CRANK to RUN
	RUN>URGENT		While turning power supply position from RUN to ACC (Emergency stop operation)
	ACC>OFF		While turning power supply position from ACC to OFF (OFF)
	OFF>LOCK		While turning power supply position from OFF (OFF) to OFF (LOCK)
	OFF>ACC		While turning power supply position from OFF (OFF) to ACC
	ON>CRANK		While turning power supply position from ON to CRANK
	OFF>SLEEP		While turning BCM status from normal mode [Power supply position is OFF (OFF)] to low power consumption mode
	LOCK>SLEEP		While turning BCM status from normal mode [Power supply position is OFF (LOCK)] to low power consumption mode
	LOCK		Power supply position is OFF (LOCK)
	OFF		Power supply position is OFF (OFF)
	ACC		Power supply position is ACC
	ON		Power supply position is ON
	ENGINE RUN		Power supply position is RUN
CRANKING	Power supply position is CRANK		
IGN Counter	0 - 39	The number of times that ignition switch is turned ON after DTC is detected <ul style="list-style-type: none"> • The number is 0 when a malfunction is detected now. • The number increases like 1 → 2 → 3...38 → 39 after returning to the normal condition whenever ignition switch OFF → ON. • The number is fixed to 39 until the self-diagnosis results are erased if it is over 39. 	

NOTE:

*: Refer to the following for details of the power supply position.

- OFF (OFF, LOCK): Ignition switch OFF
- ACC: Ignition switch ACC
- IGN: Ignition switch ON with engine stopped
- RUN: Ignition switch ON with engine running
- CRANK: At engine cranking

Power supply position shifts to "OFF (LOCK)" from "OFF (OFF)", when ignition switch is in the OFF position, shift position is in the P position, and any of the following conditions are met.

- Closing door
- Opening door
- Door is locked using door request switch
- Door is locked using Intelligent Key

The power supply position shifts to "ACC" when the push-button ignition switch (push switch) is pushed at "OFF (LOCK)".

WIPER

DIAGNOSIS SYSTEM (BCM)

< SYSTEM DESCRIPTION >

WIPER : CONSULT Function (BCM - WIPER)

INFOID:000000008377992

WORK SUPPORT

Service item	Setting item	Description	
WIPER SPEED SETTING	On	With vehicle speed (Front wiper intermittent time linked with the vehicle speed and wiper intermittent dial position)	The setting of front wiper INT operation can be changed
	Off*	Without vehicle speed (Front wiper intermittent time linked with the wiper intermittent dial position)	

*: Factory setting

DATA MONITOR

NOTE:

The following table includes information (items) inapplicable to this vehicle. For information (items) applicable to this vehicle, refer to CONSULT display items.

Monitor Item [Unit]	Description
PUSH SW [Off/On]	The switch status input from push-button ignition switch.
VEH SPEED 1 [km/h]	Displays the value of the vehicle speed signal received from combination meter via CAN communication.
FR WIPER HI [Off/On]	Status of each switch judged by BCM using the combination switch reading function
FR WIPER LOW [Off/On]	
FR WASHER SW [Off/On]	
FR WIPER INT [Off/On]	
FR WIPER STOP [Off/On]	Displays the status of the front wiper stop position signal received from IPDM E/R via CAN communication.
INT VOLUME [1 - 7]	Status of each switch judged by BCM using the combination switch reading function
RR WIPER ON [Off/On]	Status of each switch judged by BCM using the combination switch reading function
RR WIPER INT [Off/On]	
RR WASHER SW [Off/On]	
RR WIPER STOP [Off/On]	Rear wiper motor (stop position) status input from the rear wiper motor

ACTIVE TEST

Test item	Operation	Description
FR WIPER	Hi	Transmits the front wiper request signal (HI) to IPDM E/R via CAN communication to operate the front wiper HI operation.
	Lo	Transmits the front wiper request signal (LO) to IPDM E/R via CAN communication to operate the front wiper LO operation.
	INT	Transmits the front wiper request signal (INT) to IPDM E/R via CAN communication to operate the front wiper INT operation.
	Off	Stops transmitting the front wiper request signal to stop the front wiper operation.

DIAGNOSIS SYSTEM (BCM)

< SYSTEM DESCRIPTION >

Test item	Operation	Description
RR WIPER	On	Output the voltage to operate the rear wiper motor.
	Off	Stops the voltage to stop the rear wiper motor.

DIAGNOSIS SYSTEM (IPDM E/R)

< SYSTEM DESCRIPTION >

DIAGNOSIS SYSTEM (IPDM E/R)

Diagnosis Description

INFOID:000000008843606

AUTO ACTIVE TEST

Description

In auto active test, the IPDM E/R sends a drive signal to the following systems to check their operation.

- Oil pressure warning lamp
- Front wiper (LO, HI)
- Parking lamp
- License plate lamp
- Tail lamp
- Side marker lamp
- Front fog lamp
- Headlamp (LO, HI)
- A/C compressor (magnet clutch)
- Cooling fan

Operation Procedure

NOTE:

Never perform auto active test in the following condition.

- Passenger door is open.
- CONSULT is connected.

1. Close the hood and lift the wiper arms from the windshield. (Prevent windshield damage due to wiper operation)

NOTE:

When auto active test is performed with hood opened, sprinkle water on windshield beforehand.

2. Turn the ignition switch OFF.
3. Turn the ignition switch ON, and within 20 seconds, press the front door switch (driver side) 10 times. Then turn the ignition switch OFF.
4. Turn the ignition switch ON within 10 seconds. After that the horn sounds once and the auto active test starts.

NOTE:

Engine starts when ignition switch is turned ON while brake pedal is depressed.

5. The oil pressure warning lamp starts blinking when the auto active test starts.
6. After a series of the following operations is repeated 3 times, auto active test is completed.

NOTE:

- When auto active test has to be cancelled halfway through test, turn the ignition switch OFF.
- When auto active test is not activated, door switch may be the cause. Check door switch. Refer to [DLK-210](#), "[Component Function Check](#)".

Inspection in Auto Active Test

When auto active test is actuated, the following 6 steps are repeated 3 times.

Operation sequence	Inspection location	Operation
1	Oil pressure warning lamp	Blinks continuously during operation of auto active test
2	Front wiper motor	LO for 5 seconds → HI for 5 seconds
3	<ul style="list-style-type: none">• Parking lamp• License plate lamp• Tail lamp• Side marker lamp• Front fog lamp	10 seconds
4	Headlamp	<ul style="list-style-type: none">• LO 10 seconds• HI ON ↔ OFF 5 times
5	A/C compressor (magnet clutch)	ON ↔ OFF 5 times
6	Cooling fan	LO for 5 seconds → MID for 3 seconds → HI for 2 seconds

DIAGNOSIS SYSTEM (IPDM E/R)

< SYSTEM DESCRIPTION >

Concept of auto active test

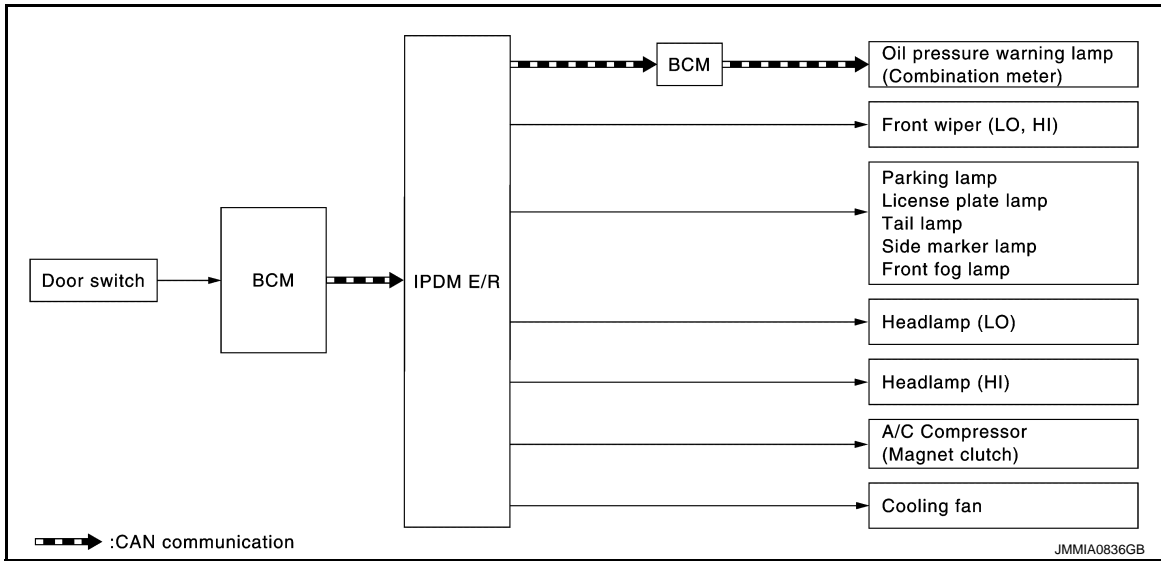

- IPDM E/R starts the auto active test with the door switch signals transmitted by BCM via CAN communication. Therefore, the CAN communication line between IPDM E/R and BCM is considered normal if the auto active test starts successfully.
- The auto active test facilitates troubleshooting if any systems controlled by IPDM E/R cannot be operated.

Diagnosis chart in auto active test

Symptom	Inspection contents	Possible cause
Any of the following components do not operate • Parking lamp • License plate lamp • Tail lamp • Side marker lamp • Front fog lamp • Headlamp (HI, LO) • Front wiper motor	Perform auto active test. Does the applicable system operate?	YES BCM signal input circuit
		NO • Lamp or motor • Lamp or motor ground circuit • Harness or connector between IPDM E/R and applicable system • IPDM E/R
A/C compressor does not operate	Perform auto active test. Does the magnet clutch operate?	YES • Combination meter signal input circuit • CAN communication signal between Combination meter and ECM • CAN communication signal between ECM and IPDM E/R
		NO • Magnet clutch • Harness or connector between IPDM E/R and magnet clutch • IPDM E/R
Oil pressure warning lamp does not operate	Perform auto active test. Does the oil pressure warning lamp blink?	YES • Harness or connector between IPDM E/R and oil pressure switch • Oil pressure switch • IPDM E/R
		NO • CAN communication signal between IPDM E/R and BCM • CAN communication signal between BCM and Combination meter • Combination meter

DIAGNOSIS SYSTEM (IPDM E/R)

< SYSTEM DESCRIPTION >

Symptom	Inspection contents	Possible cause
Cooling fan does not operate	Perform auto active test. Does the cooling fan operate?	YES <ul style="list-style-type: none"> ECM signal input circuit CAN communication signal between ECM and IPDM E/R
		NO <ul style="list-style-type: none"> Cooling fan Harness or connector between cooling fan and cooling fan relay Harness or connector between IPDM E/R and cooling fan relay Cooling fan relay IPDM E/R

CONSULT Function (IPDM E/R)

INFOID:000000008843607

APPLICATION ITEM

CONSULT performs the following functions via CAN communication with IPDM E/R.

Diagnosis mode	Description
Ecu Identification	Allows confirmation of IPDM E/R part number.
Self Diagnostic Result	Displays the diagnosis results judged by IPDM E/R.
Data Monitor	Displays the real-time input/output data from IPDM E/R input/output data.
Active Test	IPDM E/R can provide a drive signal to electronic components to check their operations.
CAN Diag Support Monitor	The results of transmit/receive diagnosis of CAN communication can be read.

SELF DIAGNOSTIC RESULT

Refer to [PCS-24, "DTC Index"](#).

DATA MONITOR

NOTE:

The following table includes information (items) inapplicable to this vehicle. For information (items) applicable to this vehicle, refer to CONSULT display items.

Monitor Item [Unit]	MAIN SIGNALS	Description
MOTOR FAN REQ [1/2/3/4]	×	Displays the value of the cooling fan speed signal received from ECM via CAN communication.
AC COMP REQ [Off/On]	×	Displays the status of the A/C compressor request signal received from ECM via CAN communication.
TAIL&CLR REQ [Off/On]	×	Displays the status of the position light request signal received from BCM via CAN communication.
HL LO REQ [Off/On]	×	Displays the status of the low beam request signal received from BCM via CAN communication.
HL HI REQ [Off/On]	×	Displays the status of the high beam request signal received from BCM via CAN communication.
FR FOG REQ [Off/On]	×	Displays the status of the front fog light request signal received from BCM via CAN communication.
FR WIP REQ [Stop/1LOW/Low/Hi]	×	Displays the status of the front wiper request signal received from BCM via CAN communication.
WIP AUTO STOP [STOP P/ACT P]	×	Displays the status of the front wiper stop position signal judged by IPDM E/R.
WIP PROT [Off/BLOCK]	×	Displays the status of the front wiper fail-safe operation judged by IPDM E/R.
IGN RLY1 -REQ [Off/On]		Displays the status of the ignition switch ON signal received from BCM via CAN communication.
IGN RLY [Off/On]	×	Displays the status of the ignition relay judged by IPDM E/R.

DIAGNOSIS SYSTEM (IPDM E/R)

< SYSTEM DESCRIPTION >

Monitor Item [Unit]	MAIN SIG- NALS	Description
PUSH SW [Off/On]		Displays the status of the push-button ignition switch judged by IPDM E/R.
INTER/NP SW [Off/On]		Displays the status of the shift position judged by IPDM E/R.
ST RLY CONT [Off/On]		Displays the status of the starter relay status signal received from BCM via CAN communication.
IHBT RLY -REQ [Off/On]		Displays the status of the starter control relay signal received from BCM via CAN communication.
ST/INHI RLY [Off/ ST /INHI/UNKWN]		Displays the status of the starter relay and starter control relay judged by IPDM E/R.
DETENT SW [Off/On]		Displays the status of the CVT shift selector (detention switch) judged by IPDM E/R.
S/L RLY -REQ [Off/On]		NOTE: The item is indicated, but not monitored.
S/L STATE [LOCK/UNLK/UNKWN]		NOTE: The item is indicated, but not monitored.
DTRL REQ [Off/On]		Displays the status of the daytime running light request signal received from BCM via CAN communication. NOTE: This item is monitored only on the vehicle with daytime running light system.
OIL P SW [Open/Close]		Displays the status of the oil pressure switch judged by IPDM E/R.
HOOD SW [Off/On]		NOTE: The item is indicated, but not monitored.
HL WASHER REQ [Off/On]		NOTE: The item is indicated, but not monitored.
THFT HRN REQ [Off/On]		Displays the status of the theft warning horn request signal received from BCM via CAN communication.
HORN CHIRP [Off/On]		Displays the status of the horn reminder signal received from BCM via CAN communication.
CRNRNG LMP REQ [Off/On]		NOTE: The item is indicated, but not monitored.

ACTIVE TEST

Test item

Test item	Operation	Description
CORNERING LAMP	Off	NOTE: The item is indicated, but cannot be tested.
	LH	
	RH	
HORN	On	Operates horn relay for 20 ms.
FRONT WIPER	Off	OFF
	Lo	Operates the front wiper relay.
	Hi	Operates the front wiper relay and front wiper high relay.
MOTOR FAN	1	OFF
	2	Operates the cooling fan relay-1.
	3	Operates the cooling fan relay-2.
	4	Operates the cooling fan relay-2 and cooling fan relay-3.
HEAD LAMP WASHER	On	NOTE: The item is indicated, but cannot be tested.

DIAGNOSIS SYSTEM (IPDM E/R)

< SYSTEM DESCRIPTION >

Test item	Operation	Description
EXTERNAL LAMPS	Off	OFF
	TAIL	Operates the tail lamp relay and the daytime running light relay.
	Lo	Operates the headlamp low relay.
	Hi	Operates the headlamp low relay and ON/OFF the headlamp high relay at 1 second intervals.
	Fog	Operates the front fog lamp relay.

A
B
C
D
E
F
G
H
I
J
K
M
N
O
P

WW

BCM, IPDM E/R

< ECU DIAGNOSIS INFORMATION >

ECU DIAGNOSIS INFORMATION

BCM, IPDM E/R

List of ECU Reference

INFOID:000000008377995

ECU	Reference
BCM	BCS-40, "Reference Value"
	BCS-62, "Fail-safe"
	BCS-62, "DTC Inspection Priority Chart"
	BCS-63, "DTC Index"
IPDM E/R	PCS-16, "Reference Value"
	PCS-23, "Fail-safe"
	PCS-24, "DTC Index"

WIPER AND WASHER SYSTEM

< WIRING DIAGRAM >

WIRING DIAGRAM

WIPER AND WASHER SYSTEM

Wiring Diagram

INFOID:000000008377996

For connector terminal arrangements, harness layouts, and alphabets in a  (option abbreviation; if not described in wiring diagram), refer to [GI-12, "Connector Information"](#).

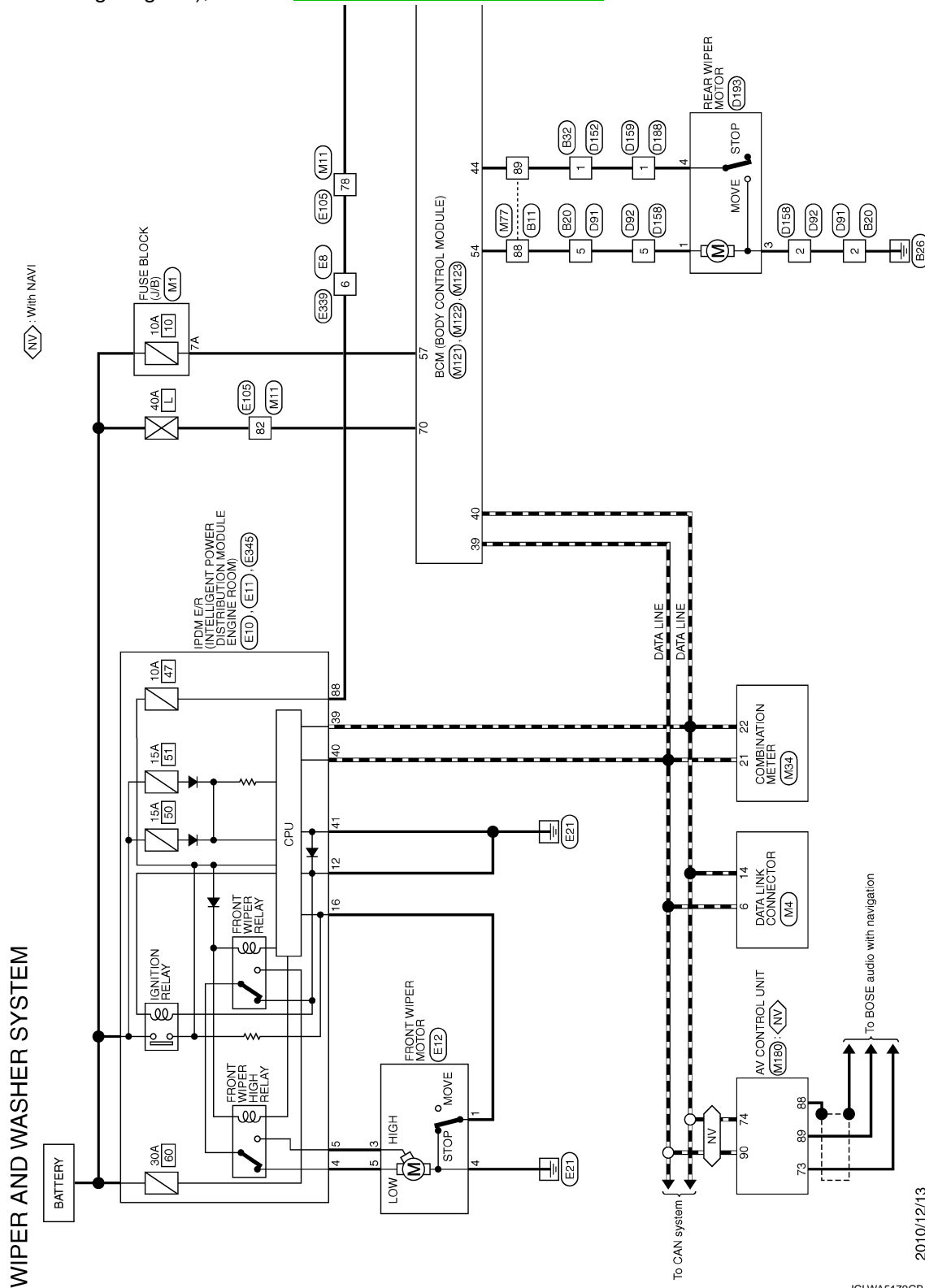

2010/12/13

JCLWA5179GB

A
B
C
D
E
F
G
H
I
J
K
L
M
N
O
P

WW

WIPER AND WASHER SYSTEM

< WIRING DIAGRAM >

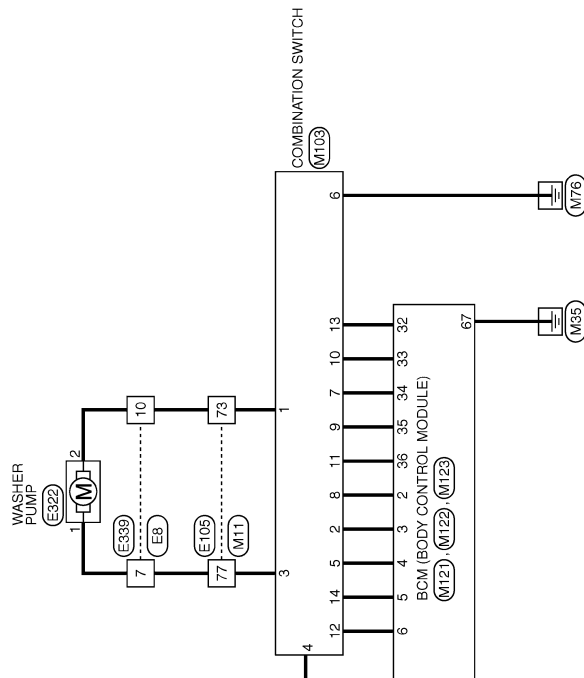

JCLWA5180GB

DIAGNOSIS AND REPAIR WORK FLOW

< BASIC INSPECTION >

BASIC INSPECTION

DIAGNOSIS AND REPAIR WORK FLOW

Work Flow

INFOID:000000008377997

OVERALL SEQUENCE

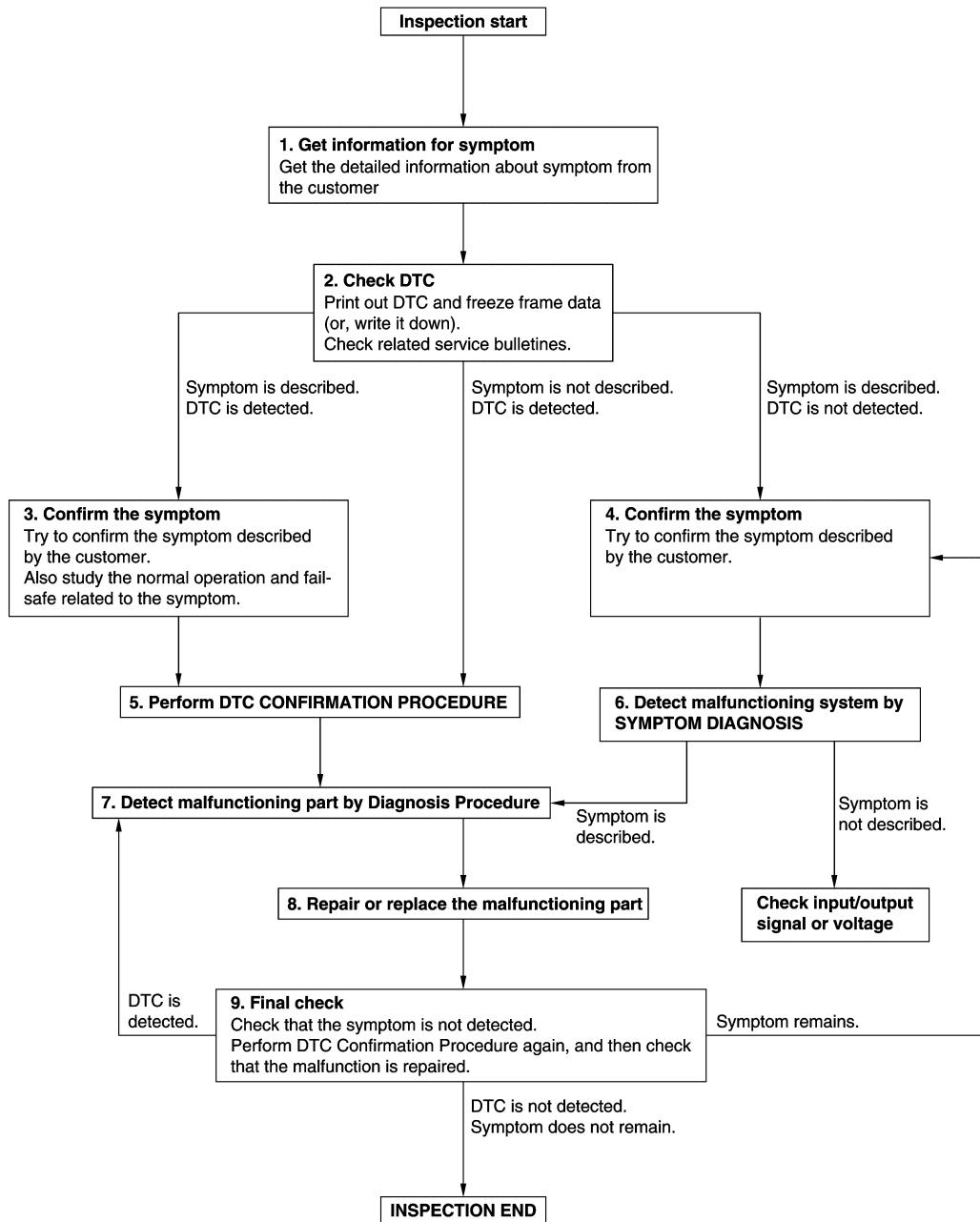

DETAILED FLOW

JMKIA8652GB

DIAGNOSIS AND REPAIR WORK FLOW

< BASIC INSPECTION >

1. GET INFORMATION FOR SYMPTOM

1. Get detailed information from the customer about the symptom (the condition and the environment when the incident/malfunction occurs).
2. Check operation condition of the function that is malfunctioning.

>> GO TO 2.

2. CHECK DTC

1. Check DTC.
2. Perform the following procedure if DTC is detected.
 - Record DTC and freeze frame data (Print them out using CONSULT.)
 - Erase DTC.
 - Study the relationship between the cause detected by DTC and the symptom described by the customer.
3. Check related service bulletins for information.

Are any symptoms described and any DTC detected?

Symptom is described, DTC is detected>>GO TO 3.

Symptom is described, DTC is not detected>>GO TO 4.

Symptom is not described, DTC is detected>>GO TO 5.

3. CONFIRM THE SYMPTOM

Try to confirm the symptom described by the customer.

Also study the normal operation and fail-safe related to the symptom.

Verify relation between the symptom and the condition when the symptom is detected.

>> GO TO 5.

4. CONFIRM THE SYMPTOM

Try to confirm the symptom described by the customer.

Verify relation between the symptom and the condition when the symptom is detected.

>> GO TO 6.

5. PERFORM DTC CONFIRMATION PROCEDURE

Perform DTC CONFIRMATION PROCEDURE for the detected DTC, and then check that DTC is detected again. At this time, always connect CONSULT to the vehicle, and check self diagnostic results in real time.

If two or more DTCs are detected, refer to [BCS-62. "DTC Inspection Priority Chart"](#) (BCM) or [PCS-24. "DTC Index"](#) (IPDM E/R), and determine trouble diagnosis order.

NOTE:

- Freeze frame data is useful if the DTC is not detected.
- Perform Component Function Check if DTC CONFIRMATION PROCEDURE is not included on Service Manual. This simplified check procedure is an effective alternative though DTC cannot be detected during this check.

If the result of Component Function Check is NG, it is the same as the detection of DTC by DTC CONFIRMATION PROCEDURE.

Is DTC detected?

YES >> GO TO 7.

NO >> Check according to [GI-42. "Intermittent Incident"](#).

6. DETECT MALFUNCTIONING SYSTEM BY SYMPTOM DIAGNOSIS

Detect malfunctioning system according to SYMPTOM DIAGNOSIS based on the confirmed symptom in step 4, and determine the trouble diagnosis order based on possible causes and symptom.

Is the symptom described?

YES >> GO TO 7.

NO >> Monitor input data from related sensors or check voltage of related module terminals using CONSULT.

7. DETECT MALFUNCTIONING PART BY DIAGNOSIS PROCEDURE

DIAGNOSIS AND REPAIR WORK FLOW

< BASIC INSPECTION >

Inspect according to Diagnosis Procedure of the system.

Is malfunctioning part detected?

YES >> GO TO 8.

NO >> Check according to [GI-42. "Intermittent Incident"](#).

8. REPAIR OR REPLACE THE MALFUNCTIONING PART

1. Repair or replace the malfunctioning part.
2. Reconnect parts or connectors disconnected during Diagnosis Procedure again after repair and replacement.
3. Check DTC. If DTC is detected, erase it.

>> GO TO 9.

9. FINAL CHECK

When DTC is detected in step 2, perform DTC CONFIRMATION PROCEDURE again, and then check that the malfunction is repaired securely.

When symptom is described by the customer, refer to confirmed symptom in step 3 or 4, and check that the symptom is not detected.

Is DTC detected and does symptom remain?

YES-1 >> DTC is detected: GO TO 7.

YES-2 >> Symptom remains: GO TO 4.

NO >> Before returning the vehicle to the customer, always erase DTC.

A
B
C
D
E
F
G
H
I
J
K
M
N
O
P

WW

FRONT WIPER MOTOR LO CIRCUIT

< DTC/CIRCUIT DIAGNOSIS >

DTC/CIRCUIT DIAGNOSIS

FRONT WIPER MOTOR LO CIRCUIT

Component Function Check

INFOID:000000008377998

1. CHECK FRONT WIPER LO OPERATION

CONSULT ACTIVE TEST

1. Select "FRONT WIPER" of IPDM E/R active test item.
2. With operating the test item, check front wiper operation.

Lo : Front wiper (LO) operation

Off : Stop the front wiper.

Is front wiper (LO) operation normally?

- YES >> Front wiper motor LO circuit is normal.
 NO >> Refer to [WW-30, "Diagnosis Procedure"](#).

Diagnosis Procedure

INFOID:000000008377999

1. CHECK FRONT WIPER MOTOR (LO) OUTPUT VOLTAGE

CONSULT ACTIVE TEST

1. Turn ignition switch OFF.
2. Disconnect front wiper motor connector.
3. Turn ignition switch ON.
4. Select "FRONT WIPER" of IPDM E/R active test item.
5. With operating the test item, check voltage between front wiper motor harness connector and ground.

(+)		(-)	Condition	Voltage (Approx.)	
Front wiper motor					
Connector	Terminal				
E12	5	Ground	FRONT WIPER	Lo	9-16V
				Off	0 V

Is the inspection result normal?

- YES >> Replace front wiper motor.
 NO >> GO TO 2.

2. CHECK FRONT WIPER MOTOR (LO) CIRCUIT

1. Turn ignition switch OFF.
2. Disconnect IPDM E/R connector.
3. Check continuity between IPDM E/R harness connector and front wiper motor harness connector.

IPDM E/R		Front wiper motor		Continuity
Connector	Terminal	Connector	Terminal	
E10	4	E12	5	Existed

4. Check continuity between IPDM E/R harness connector and ground.

IPDM E/R		Ground	Continuity
Connector	Terminal		
E10	4		Not existed

Is the inspection result normal?

- YES >> Replace IPDM E/R.
 NO >> Repair or replace harness.

FRONT WIPER MOTOR HI CIRCUIT

< DTC/CIRCUIT DIAGNOSIS >

FRONT WIPER MOTOR HI CIRCUIT

Component Function Check

INFOID:000000008378000

1. CHECK FRONT WIPER HI OPERATION

CONSULT ACTIVE TEST

1. Select "FRONT WIPER" of IPDM E/R active test item.
2. With operating the test item, check front wiper operation.

Hi : Front wiper (HI) operation

Off : Stop the front wiper.

Is front wiper (HI) operation normally?

- YES >> Front wiper motor HI circuit is normal.
 NO >> Refer to [WW-31, "Diagnosis Procedure"](#).

Diagnosis Procedure

INFOID:000000008378001

1. CHECK FRONT WIPER MOTOR (HI) OUTPUT VOLTAGE

CONSULT ACTIVE TEST

1. Turn ignition switch OFF.
2. Disconnect front wiper motor connector.
3. Turn ignition switch ON.
4. Select "FRONT WIPER" of IPDM E/R active test item.
5. With operating the test item, check voltage between front wiper motor harness connector and ground.

(+)		(-)	Condition	Voltage (Approx.)	
Front wiper motor					
Connector	Terminal				
E12	3	Ground	FRONT WIPER	Hi	9-16V
				Off	0 V

Is the inspection result normal?

- YES >> Replace front wiper motor.
 NO >> GO TO 2.

2. CHECK FRONT WIPER MOTOR (HI) CIRCUIT

1. Turn ignition switch OFF.
2. Disconnect IPDM E/R connector.
3. Check continuity between IPDM E/R harness connector and front wiper motor harness connector.

IPDM E/R		Front wiper motor		Continuity
Connector	Terminal	Connector	Terminal	
E10	5	E12	3	Existed

4. Check continuity between IPDM E/R harness connector and ground.

IPDM E/R		Ground	Continuity
Connector	Terminal		
E10	5		Not existed

Is the inspection result normal?

- YES >> Replace IPDM E/R.
 NO >> Repair or replace harness.

A
B
C
D
E
F
G
H
I
J
K
M
N
O
P

WW

FRONT WIPER STOP POSITION SIGNAL CIRCUIT

< DTC/CIRCUIT DIAGNOSIS >

FRONT WIPER STOP POSITION SIGNAL CIRCUIT

Component Function Check

INFOID:000000008378002

1. CHECK FRONT WIPER STOP POSITION SIGNAL

CONSULT DATA MONITOR

1. Select "WIP AUTO STOP" of IPDM E/R data monitor item.
2. Operate the front wiper.
3. With the front wiper operation, check the monitor status.

Monitor item	Condition		Monitor status
WIP AUTO STOP	Front wiper motor	Stop position	STOP P
		Except stop position	ACT P

Is the status of item normal?

- YES >> Front wiper stop position signal circuit is normal.
 NO >> Refer to [WW-32, "Diagnosis Procedure"](#).

Diagnosis Procedure

INFOID:000000008378003

1. CHECK IPDM E/R OUTPUT VOLTAGE

1. Turn ignition switch OFF.
2. Disconnect front wiper motor connector.
3. Turn ignition switch ON.
4. Check voltage between front wiper motor harness connector and ground.

(+)		(-)	Voltage (Approx.)
Front wiper motor			
Connector	Terminal	Ground	9-16V
E12	1		

Is the inspection result normal?

- YES >> Replace front wiper motor.
 NO >> GO TO 2.

2. CHECK FRONT WIPER MOTOR CIRCUIT

1. Turn ignition switch OFF.
2. Disconnect IPDM E/R connector.
3. Check continuity between IPDM E/R harness connector and front wiper motor harness connector.

IPDM E/R		Front wiper motor		Continuity
Connector	Terminal	Connector	Terminal	
E10	16	E12	1	Existed

4. Check continuity between IPDM E/R harness connector and ground.

IPDM E/R		Ground	Continuity
Connector	Terminal		
E10	16		Not existed

Is the inspection result normal?

- YES >> Replace IPDM E/R.
 NO >> Repair or replace harness.

FRONT WIPER MOTOR GROUND CIRCUIT

< DTC/CIRCUIT DIAGNOSIS >

FRONT WIPER MOTOR GROUND CIRCUIT

Diagnosis Procedure

INFOID:000000008378004

1. CHECK FRONT WIPER MOTOR GROUND CIRCUIT

1. Turn ignition switch OFF.
2. Disconnect front wiper motor connector.
3. Check continuity between front wiper motor harness connector and ground.

Front wiper motor		Ground	Continuity
Connector	Terminal		
E12	4		Existed

Is the inspection result normal?

- YES >> INSPECTION END
NO >> Repair or replace harness.

A
B
C
D
E
F
G
H
I
J
K
M
N
O
P

WW

WASHER SWITCH

< DTC/CIRCUIT DIAGNOSIS >

WASHER SWITCH

Component Inspection

INFOID:000000008378005

1. CHECK WASHER SWITCH

1. Turn ignition switch OFF.
2. Disconnect combination switch connector.
3. Check continuity between the combination switch terminals.

- A : Terminal 4
- B : Terminal 6
- C : Terminal 3
- D : Terminal 1

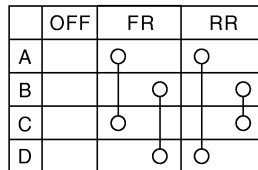

JPLIA0164GB

Combination switch		Condition	Continuity
Terminal			
3	4	Front washer switch ON	Existed
1	6		
1	4	Rear washer switch ON	
6	3		

Is the inspection result normal?

YES >> INSPECTION END

NO >> Replace combination switch (Wiper and washer switch).

REAR WIPER MOTOR CIRCUIT

< DTC/CIRCUIT DIAGNOSIS >

REAR WIPER MOTOR CIRCUIT

Component Function Check

INFOID:000000008378006

1. CHECK REAR WIPER ON OPERATION

CONSULT ACTIVE TEST

1. Select "RR WIPER" of BCM active test item.
2. With operating the test item, check rear wiper operation.

On : Rear wiper ON operation

Off : Stop the rear wiper.

Is rear wiper operation normally?

- YES >> Rear wiper motor circuit is normal.
NO >> Refer to [WW-35, "Diagnosis Procedure"](#).

Diagnosis Procedure

INFOID:000000008378007

1. CHECK REAR WIPER MOTOR OUTPUT VOLTAGE

CONSULT ACTIVE TEST

1. Turn ignition switch OFF.
2. Disconnect rear wiper motor connector.
3. Turn ignition switch ON.
4. Select "RR WIPER" of BCM active test item.
5. With operating the test item, check voltage between rear wiper motor harness connector and ground.

(+)		(-)	Condition		Voltage (Approx.)
Rear wiper motor					
Connector	Terminal	Ground	REAR WIPER	On	9-16V
D193	1				

Is the inspection result normal?

- YES >> GO TO 3.
NO >> GO TO 2.

2. CHECK REAR WIPER MOTOR CIRCUIT

1. Turn ignition switch OFF.
2. Disconnect BCM connector.
3. Check continuity between BCM harness connector and rear wiper motor harness connector.

BCM		Rear wiper motor		Continuity
Connector	Terminal	Connector	Terminal	
M122	54	D193	1	Existed

4. Check continuity between BCM harness connector and ground.

BCM		Ground	Continuity
Connector	Terminal		
M122	54		Not existed

Is the inspection result normal?

- YES >> Replace BCM. Refer to [BCS-86, "Removal and Installation"](#).
NO >> Repair or replace harness.

3. CHECK REAR WIPER MOTOR GROUND OPEN CIRCUIT

Check continuity between rear wiper motor harness connector and ground.

A
B
C
D
E
F
G
H
I
J
K
M
N
O
P

WW

REAR WIPER MOTOR CIRCUIT

< DTC/CIRCUIT DIAGNOSIS >

Rear wiper motor		Ground	Continuity
Connector	Terminal		Existed
D193	3		

Is the inspection result normal?

- YES >> Replace rear wiper motor.
- NO >> Repair or replace harness.

REAR WIPER STOP POSITION SIGNAL CIRCUIT

< DTC/CIRCUIT DIAGNOSIS >

REAR WIPER STOP POSITION SIGNAL CIRCUIT

Component Function Check

INFOID:000000008378008

1. CHECK REAR WIPER STOP POSITION SIGNAL

CONSULT DATA MONITOR

1. Select "WIPER" of BCM data monitor item.
2. Operate the rear wiper.
3. Check that "RR WIPER STOP" changes to "On" and "Off" linked with the wiper operation.

Monitor item	Condition		Monitor status
RR WIPER STOP	Rear wiper motor	Stop position	On
		Except stop position	Off

Is the status of item normal?

- YES >> Rear wiper stop position signal circuit is normal.
 NO >> Refer to [WW-37. "Diagnosis Procedure"](#).

Diagnosis Procedure

INFOID:000000008378009

1. CHECK REAR WIPER MOTOR OUTPUT VOLTAGE

1. Turn ignition switch OFF.
2. Disconnect rear wiper motor connector.
3. Turn ignition switch ON.
4. Check voltage between rear wiper motor harness connector and ground.

(+)		(-)	Voltage (Approx.)
Rear wiper motor			
Connector	Terminal	Ground	12V
D193	4		

Is the inspection result normal?

- YES >> Replace rear wiper motor.
 NO >> GO TO 2.

2. CHECK REAR WIPER MOTOR CIRCUIT

1. Turn ignition switch OFF.
2. Disconnect BCM connector.
3. Check continuity between BCM harness connector and rear wiper motor harness connector.

BCM		Rear wiper motor		Continuity
Connector	Terminal	Connector	Terminal	
M122	44	D193	4	Existed

4. Check continuity between BCM harness connector and ground.

BCM		Ground	Continuity
Connector	Terminal		
M122	44		Not existed

Is the inspection result normal?

- YES >> Replace BCM. Refer to [BCS-86. "Removal and Installation"](#).
 NO >> Repair or replace harness.

WIPER AND WASHER SYSTEM SYMPTOMS

< SYMPTOM DIAGNOSIS >

SYMPTOM DIAGNOSIS

WIPER AND WASHER SYSTEM SYMPTOMS

Symptom Table

INFOID:000000008378010

Symptom		Probable malfunction location	Inspection item	
Front wiper does not operate	HI only	<ul style="list-style-type: none"> Combination switch Harness between combination switch and BCM BCM 	Combination switch Refer to BCS-84, "Symptom Table"	
		<ul style="list-style-type: none"> IPDM E/R Harness between IPDM E/R and front wiper motor Front wiper motor 	Front wiper motor (HI) circuit Refer to WW-31, "Component Function Check" .	
		Front wiper request signal <ul style="list-style-type: none"> BCM IPDM E/R 	IPDM E/R DATA MONITOR "FR WIP REQ"	
	Lo and INT	<ul style="list-style-type: none"> Combination switch Harness between combination switch and BCM BCM 	Combination switch Refer to BCS-84, "Symptom Table"	
		<ul style="list-style-type: none"> IPDM E/R Harness between IPDM E/R and front wiper motor Front wiper motor 	Front wiper motor (LO) circuit Refer to WW-30, "Component Function Check" .	
		Front wiper request signal <ul style="list-style-type: none"> BCM IPDM E/R 	IPDM E/R DATA MONITOR "FR WIP REQ"	
	INT only	<ul style="list-style-type: none"> Combination switch Harness between combination switch and BCM BCM 	Combination switch Refer to BCS-84, "Symptom Table"	
		Front wiper request signal <ul style="list-style-type: none"> BCM IPDM E/R 	IPDM E/R DATA MONITOR "FR WIP REQ"	
	HI, LO and INT	SYMPTOM DIAGNOSIS "FRONT WIPER DOES NOT OPERATE" Refer to WW-41, "Diagnosis Procedure" .		
	Front wiper does not stop	HI only	<ul style="list-style-type: none"> Combination switch BCM 	Combination switch Refer to BCS-84, "Symptom Table"
Front wiper request signal <ul style="list-style-type: none"> BCM IPDM E/R 			IPDM E/R DATA MONITOR "FR WIP REQ"	
IPDM E/R			—	
LO only		<ul style="list-style-type: none"> Combination switch BCM 	Combination switch Refer to BCS-84, "Symptom Table"	
		Front wiper request signal <ul style="list-style-type: none"> BCM IPDM E/R 	IPDM E/R DATA MONITOR "FR WIP REQ"	
		IPDM E/R	—	
INT only		<ul style="list-style-type: none"> Combination switch BCM 	Combination switch Refer to BCS-84, "Symptom Table"	
		Front wiper request signal <ul style="list-style-type: none"> BCM IPDM E/R 	IPDM E/R DATA MONITOR "FR WIP REQ"	

WIPER AND WASHER SYSTEM SYMPTOMS

< SYMPTOM DIAGNOSIS >

Symptom	Probable malfunction location	Inspection item
Front wiper does not operate normally	Intermittent adjustment cannot be performed.	<ul style="list-style-type: none"> • Combination switch • Harness between combination switch and BCM • BCM Refer to BCS-84, "Symptom Table"
	BCM	—
	Intermittent control linked with vehicle speed cannot be performed	Check that the wiper setting is linked with vehicle speed Refer to WW-17, "WIPER : CONSULT Function (BCM - WIPER)" .
	Wiper is not linked to the washer operation.	<ul style="list-style-type: none"> • Combination switch • Harness between combination switch and BCM • BCM Refer to BCS-84, "Symptom Table"
	BCM	—
Does not return to stop position. [Repeatedly operates for 10 seconds and then stops for 20 seconds. (Fail-safe)]	<ul style="list-style-type: none"> • IPDM E/R • Harness between IPDM E/R and front wiper motor • Front wiper motor Front wiper stop position signal circuit Refer to WW-32, "Component Function Check"	
Rear wiper does not operate	ON only	<ul style="list-style-type: none"> • Combination switch • Harness between combination switch and BCM • BCM Refer to BCS-84, "Symptom Table"
	INT only	<ul style="list-style-type: none"> • Combination switch • Harness between combination switch and BCM • BCM Refer to BCS-84, "Symptom Table"
	ON and INT	<ul style="list-style-type: none"> • Combination switch • Harness between combination switch and BCM • BCM Refer to BCS-84, "Symptom Table"
		<ul style="list-style-type: none"> • BCM • Harness between rear wiper motor and BCM • Harness between rear wiper motor and ground • Rear wiper motor Rear wiper motor circuit Refer to BCS-84, "Symptom Table"
Rear wiper does not stop	ON only	<ul style="list-style-type: none"> • Combination switch • BCM Refer to BCS-84, "Symptom Table"
	INT only	<ul style="list-style-type: none"> • Combination switch • BCM Refer to BCS-84, "Symptom Table"
Rear wiper does not operate normally	Wiper is not linked to the washer operation.	<ul style="list-style-type: none"> • Combination switch • Harness between rear wiper motor and BCM • BCM Refer to BCS-84, "Symptom Table"
	BCM	—
Rear wiper does not return to the stop position. [Stops after a five-second operation. (Fail-safe)]	<ul style="list-style-type: none"> • BCM • Harness between rear wiper motor and BCM • Rear wiper motor Rear wiper stop position signal circuit Refer to WW-37, "Component Function Check"	

A
B
C
D
E
F
G
H
I
J
K
WW
M
N
O
P

NORMAL OPERATING CONDITION

< SYMPTOM DIAGNOSIS >

NORMAL OPERATING CONDITION

Description

INFOID:000000008378011

FRONT WIPER MOTOR PROTECTION FUNCTION

- IPDM E/R may stop the front wiper to protect the front wiper motor if any obstruction (operation resistance) such as a large amount of snow is detected during the front wiper operation.
- At that time turn OFF the front wiper and remove the foreign object. Then wait for approximately 20 seconds or more and reactivate the front wiper. The wiper will operate normally.

REAR WIPER MOTOR PROTECTION FUNCTION

- BCM may stop rear wiper to protect the rear wiper motor when the rear wiper is stopped for 5 seconds or more due to a snowfall.
- Rear wiper operates normally one minute after the obstacles are removed with rear wiper OFF.

FRONT WIPER DOES NOT OPERATE

< SYMPTOM DIAGNOSIS >

FRONT WIPER DOES NOT OPERATE

Description

INFOID:000000008378012

The front wiper does not operate under any operation conditions.

Diagnosis Procedure

INFOID:000000008378013

1. CHECK WIPER RELAY OPERATION

CONSULT ACTIVE TEST

1. Select "FRONT WIPER" of IPDM E/R active test item.
2. With operating the test item, check front wiper operation.

Lo : Front wiper LO operation

Hi : Front wiper HI operation

Off : Stop the front wiper.

Is front wiper operation normally?

YES >> GO TO 5.

NO >> GO TO 2.

2. CHECK FUSES

Check that the following fuse is not fusing.

Unit	Location	No.	Capacity
Front wiper motor	IPDM E/R	60	30 A

Is the inspection result normal?

YES >> GO TO 3.

NO >> Replace the fuse with a new one after repairing the applicable circuit.

3. CHECK FRONT WIPER MOTOR GROUND CIRCUIT

Check front wiper motor ground circuit. Refer to [WW-33, "Diagnosis Procedure"](#).

Is the inspection result normal?

YES >> GO TO 4.

NO >> Repair or replace harness.

4. CHECK FRONT WIPER MOTOR INPUT VOLTAGE

CONSULT ACTIVE TEST

1. Turn ignition switch OFF.
2. Disconnect front wiper motor connector.
3. Turn ignition switch ON.
4. Select "FRONT WIPER" of IPDM E/R active test item.
5. With operating the test item, check voltage between front wiper motor harness connector and ground.

(+)		(-)	Condition	Voltage (Approx.)
Connector	Terminal			
E12	5	Ground	Lo	9-16V
			Off	0 V
	3		Hi	9-16V
			Off	0 V

Is the inspection result normal?

YES >> Replace front wiper motor.

NO >> Replace IPDM E/R.

FRONT WIPER DOES NOT OPERATE

< SYMPTOM DIAGNOSIS >

5. CHECK FRONT WIPER REQUEST SIGNAL INPUT

CONSULT DATA MONITOR

1. Select "FR WIP REQ" of IPDM E/R data monitor item.
2. Switch the front wiper switch to HI and LO.
3. With operating the front wiper switch, check the status of "FR WIP REQ".

Monitor item	Condition		Monitor status
FR WIP REQ	Front wiper switch HI	On	Hi
		Off	Stop
	Front wiper switch LO	On	Low
		Off	Stop

Is the inspection result normal?

YES >> Replace IPDM E/R.

NO >> GO TO 6.

6. CHECK COMBINATION SWITCH

Perform the inspection of the combination switch. Refer to [BCS-84. "Symptom Table"](#).

Is combination switch normal?

YES >> Replace BCM. Refer to [BCS-86. "Removal and Installation"](#).

NO >> Repair or replace the applicable parts.

FRONT WIPER

< REMOVAL AND INSTALLATION >

REMOVAL AND INSTALLATION

FRONT WIPER

Exploded View

INFOID:000000008378014

REMOVAL VIEW

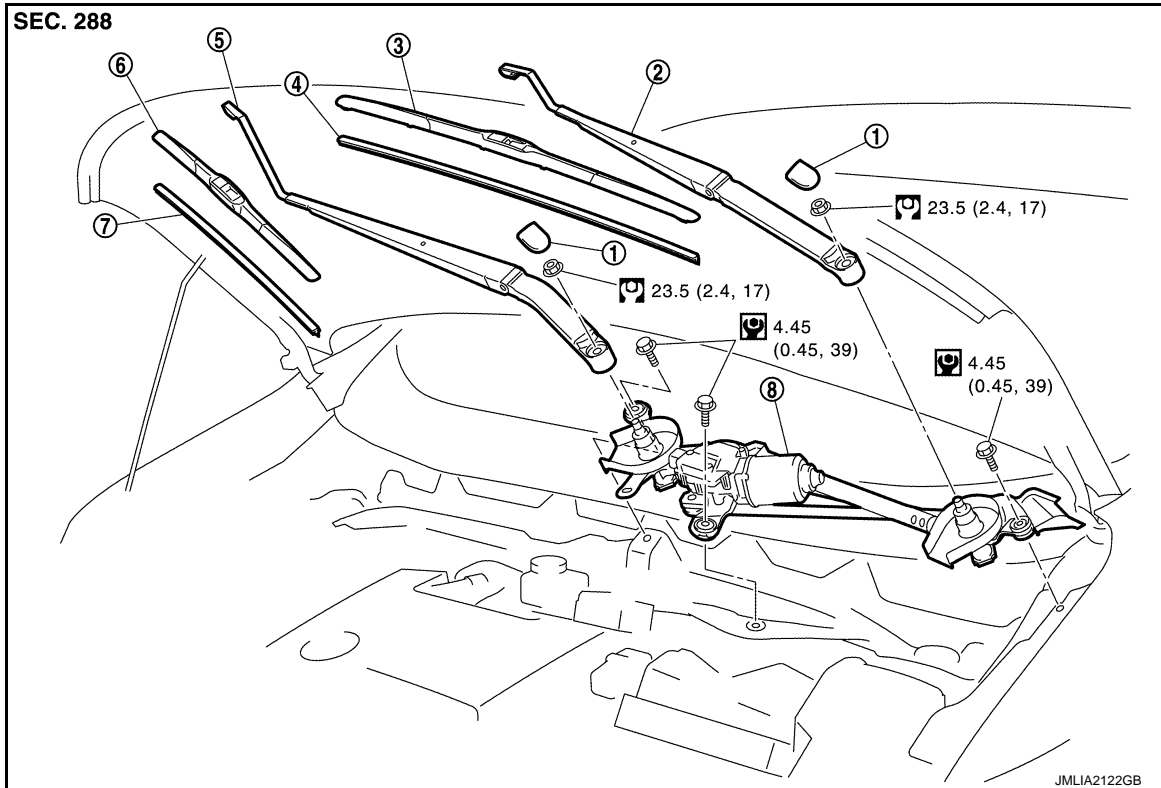

- 1. Front wiper arm cap
- 4. Front wiper refill LH
- 7. Front wiper refill RH

- 2. Front wiper arm LH
- 5. Front wiper arm RH
- 8. Front wiper drive assembly

- 3. Front wiper blade LH
- 6. Front wiper blade RH

 : N·m (kg-m, in-lb)

 : N·m (kg-m, ft-lb)

DISASSEMBLY VIEW

A
B
C
D
E
F
G
H
I
J
K
M
N
O
P

WW

FRONT WIPER

< REMOVAL AND INSTALLATION >

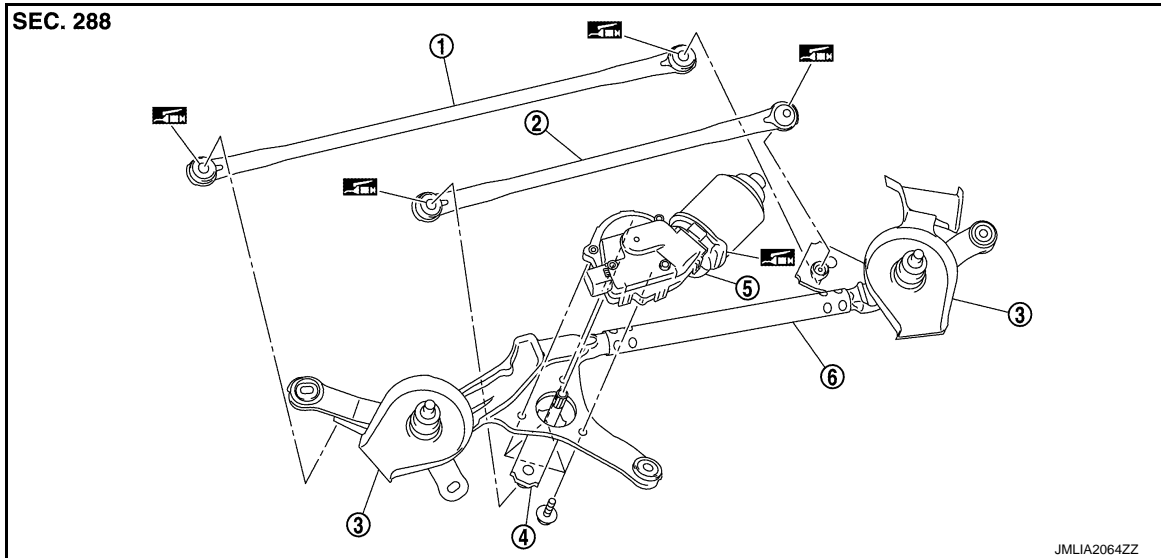

- | | | |
|--------------------|-------------------------------|----------------------|
| 1. Wiper linkage 2 | 2. Wiper linkage 1 | 3. Shaft seal |
| 4. Motor arm | 5. Front wiper motor assembly | 6. Front wiper frame |

: Multi-purpose grease or an equivalent

WIPER ARM

WIPER ARM : Removal and Installation

INFOID:000000008378015

REMOVAL

1. Operate front wiper to move it to the auto stop position.
2. Fully open hood assembly.
3. Pull front wiper arm caps in direction indicated by arrow as shown in the figure. Remove front wiper arm caps.

 : Pawl

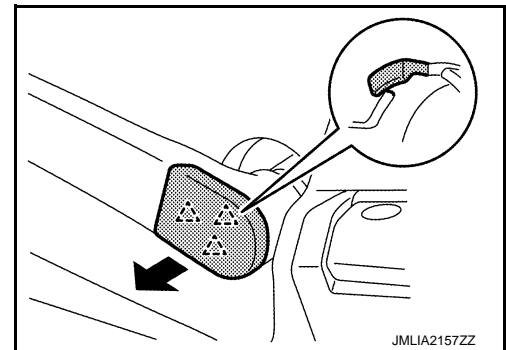

4. Remove front wiper arm mounting nuts.
5. Raise front wiper arm, and remove front wiper arm from the front wiper drive assembly.

INSTALLATION

1. Clean front wiper arm mount as shown in the figure to prevent nuts from being loosened.

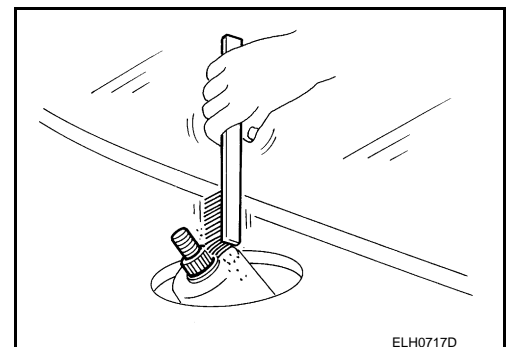

FRONT WIPER

< REMOVAL AND INSTALLATION >

- Operate front wiper motor to move the wiper to the auto stop position.
- Install front wiper arm to front wiper drive assembly. Temporarily tighten mounting nut.
- Adjust front wiper blade position. Refer to [WW-45. "WIPER ARM : Adjustment"](#).
- Install front wiper arms by tightening the mounting nuts.
- For the specified torque, refer to [WW-43. "Exploded View"](#).
- Operation wiper to move it to the auto stop position.

CAUTION:

Before operating wiper, inject washer fluid so that windshield glass damage by wiper operation is prevented.

- Check that front wiper blades stop at the specified position.
- Install front wiper arm caps.

WIPER ARM : Adjustment

INFOID:000000008378016

WIPER BLADE POSITION ADJUSTMENT

Clearance between the end of cowl top cover/ front fender cover and the top of front wiper blade center.

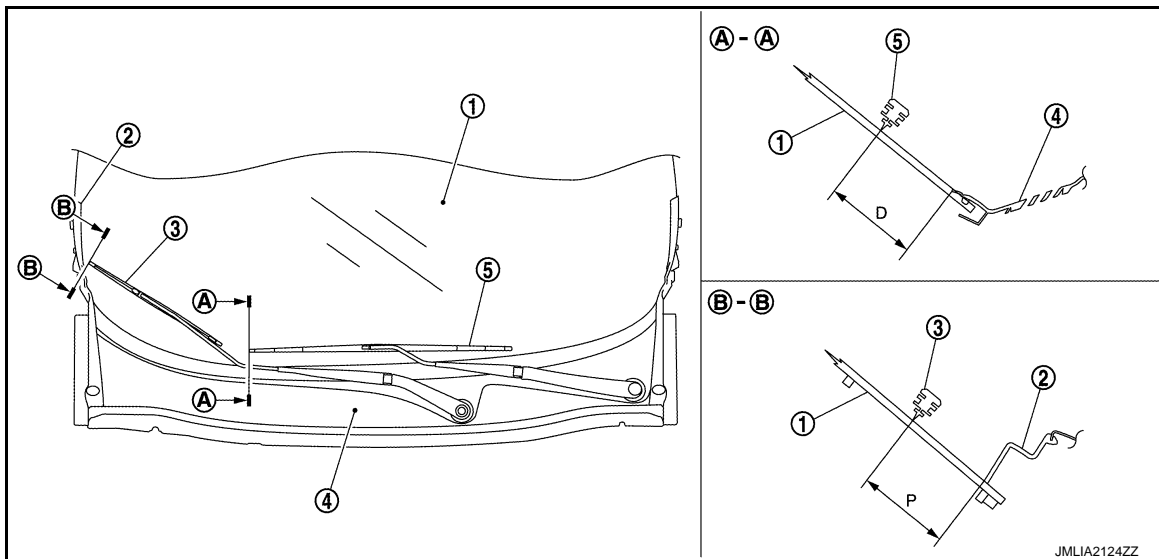

1. Windshield glass

2. Front fender cover

3. Front wiper blade RH

4. Cowl top cover

5. Front wiper blade LH

Standard clearance

D : 35.0 ± 7.5 mm (1.378 ± 0.295 in)

P : 37.2 ± 7.5 mm (0.295 ± 0.295 in)

WIPER BLADE

WIPER BLADE : Removal and Installation

INFOID:000000008378017

REMOVAL

- Lift up front wiper arm, and set to the position where wiper arm can be locked back.

FRONT WIPER

< REMOVAL AND INSTALLATION >

2. Remove lock lever (A) of front wiper blade (1). Pull front wiper blade in the direction indicated by the arrow as shown in the figure to remove front wiper blade from front wiper arm (2).

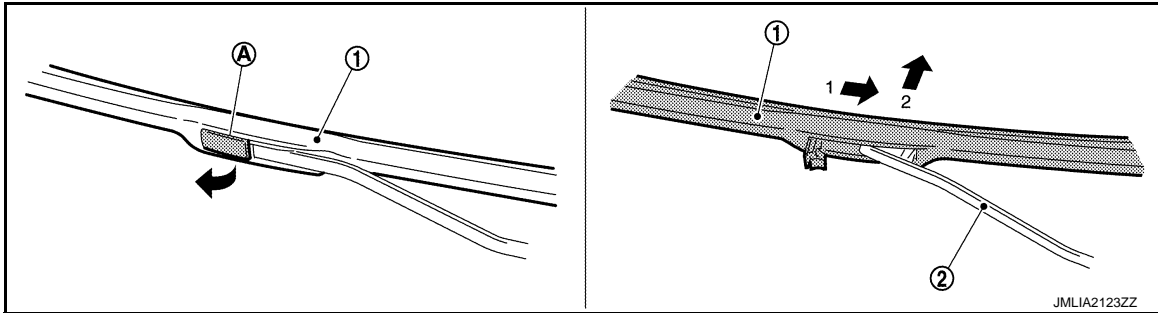

CAUTION:

Wrap wiper arm using a shop cloth so that wiper blade does not damage windshield glass.

INSTALLATION

Install in the reverse order of removal.

WIPER REFILL

WIPER REFILL : Removal and Installation

INFOID:000000008378018

REMOVAL

1. Remove front wiper blade from the front wiper arm. Refer to [WW-45, "WIPER BLADE : Removal and Installation"](#).
2. From portion (A) of front wiper refill (1), disengage front wiper blade portion (B) and remove front wiper refill in the direction indicated by the arrow as shown in the figure.

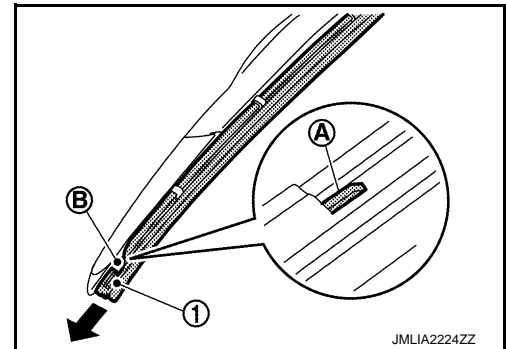

INSTALLATION

Note the following item, and then install in the reverse order of removal.

CAUTION:

- For installation of vertebra (1), align cutout of vertebra to convex portion (A) of wiper refill (2) as shown in the figure.

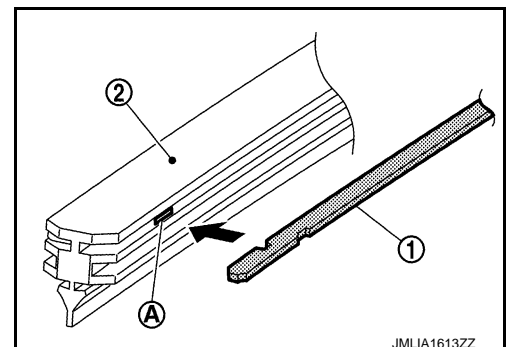

- For installation of wiper refill, check that wiper refill is not twisted while installing.
- Check that wiper refill is inserted normally from the correct direction.

WIPER DRIVE ASSEMBLY

WIPER DRIVE ASSEMBLY : Removal and Installation

INFOID:000000008378019

REMOVAL

FRONT WIPER

< REMOVAL AND INSTALLATION >

1. Remove front wiper arm (LH and RH). Refer to [WW-44, "WIPER ARM : Removal and Installation"](#).
2. Remove cowl top cover. Refer to [EXT-21, "Removal and Installation"](#).
3. Disconnect front wiper motor harness connector.
4. Remove mounting bolts from front wiper drive assembly.
5. Remove front wiper drive assembly from the vehicle.

INSTALLATION

Install in the reverse order of removal.

WIPER DRIVE ASSEMBLY : Disassembly and Assembly

INFOID:000000008378020

DISASSEMBLY

1. Remove wiper linkage 1 and 2 from the front wiper frame.
CAUTION:
Never bend the linkage or damage the plastic part of the ball joint when removing the wiper linkage.
2. Remove wiper motor mounting nuts, and then remove the motor arm.
3. Remove wiper motor mounting bolts, and then remove the front wiper motor from the front wiper frame.

ASSEMBLY

1. Connect front wiper motor harness connector.
2. Operate front wiper to move it to the auto stop position.
3. Disconnect front wiper motor harness connector.
4. Install front wiper motor to front wiper frame.
5. Install front wiper motor to the motor arm.
6. Install wiper linkage 1 to the front wiper motor and the front wiper frame.
7. Install wiper linkage 2 to the front wiper frame.

CAUTION:

- Never drop wiper motor or cause it to come into contact with other parts.
- Be careful for the grease condition at the wiper motor and wiper linkage joint (retainer). Apply multi-purpose grease or an equivalent if necessary.

A
B
C
D
E
F
G
H
I
J
K

WW

M
N
O
P

REAR WIPER

< REMOVAL AND INSTALLATION >

REAR WIPER

Exploded View

INFOID:000000008378021

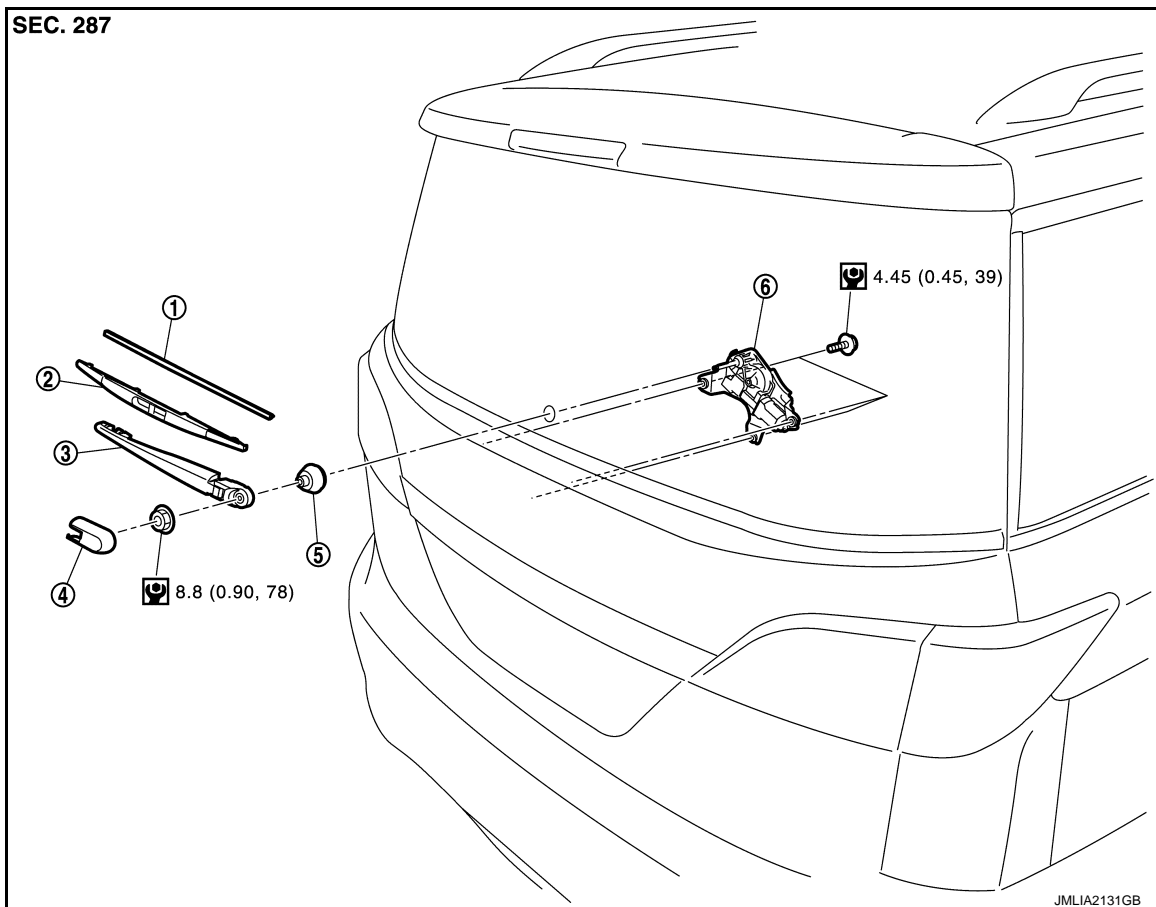

- | | | |
|-------------------------|---------------------|---------------------|
| 1. Rear wiper refill | 2. Rear wiper blade | 3. Rear wiper arm |
| 4. Rear wiper arm cover | 5. Pivot seal | 6. Rear wiper motor |

 : N·m (kg·m, in·lb)

WIPER ARM

WIPER ARM : Removal and Installation

INFOID:000000008378022

REMOVAL

1. Operate rear wiper to move it to the auto stop position.
2. Pull rear wiper arm caps in direction indicated by arrow as shown in the figure. Remove rear wiper arm caps.

 : Pawl

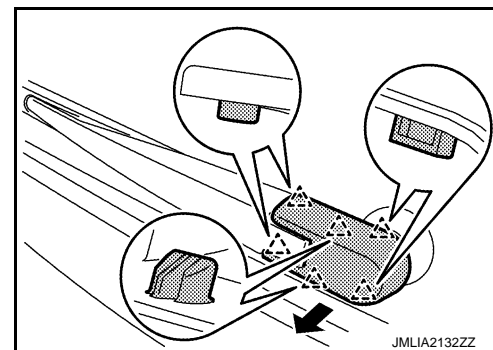

3. Remove rear wiper arm mounting nuts.

REAR WIPER

< REMOVAL AND INSTALLATION >

4. Raise rear wiper arm, and remove rear wiper arm from the vehicle.

INSTALLATION

1. Clean rear wiper arm mount as shown in the figure to prevent nuts from being loosened.

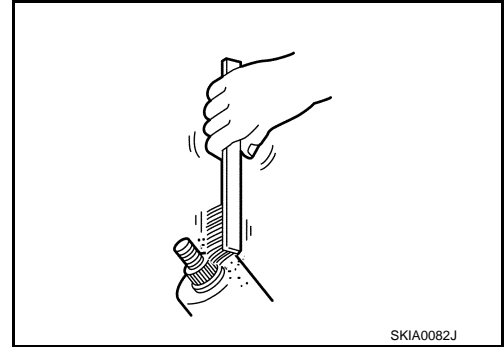

2. Operate rear wiper motor to move the wiper to the auto stop position.
3. Install rear wiper arm to wiper drive assembly. Temporarily tighten mounting nut.
4. Adjust rear wiper blade position. Refer to [WW-49, "WIPER ARM : Adjustment"](#).
5. Install rear wiper arms by tightening the mounting nuts. For the specified torque, refer to [WW-48, "Exploded View"](#).

6. Operate rear wiper to move it to the auto stop position.

CAUTION:

Before operating rear wiper, inject washer fluid so that windshield glass damage by rear wiper operation is prevented.

7. Check that rear wiper blades stop at the specified position.
8. Install rear wiper arm caps.

WIPER ARM : Adjustment

INFOID:000000008378023

REAR WIPER BLADE POSITION ADJUSTMENT

Set the wiper blade top on the defrosting wire (A) (clearance between the end of back door glass and the top of wiper blade center).

Standard clearance

1. **Rear wiper blade**
 2. **Back door window glass**
 3. **Back door panel**
 4. **Back door trim**
- A : Rear defogger wire print**
L : 50.2 ± 7.5 mm (1.976 ± 0.295 in)

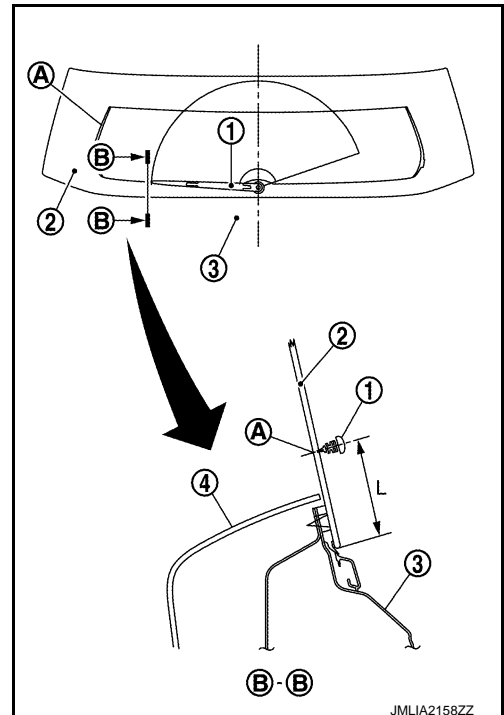

WIPER BLADE

REAR WIPER

< REMOVAL AND INSTALLATION >

WIPER BLADE : Removal and Installation

INFOID:000000008378024

REMOVAL

1. Lift up and hold rear wiper arm. Remove rear wiper blade (1) from rear wiper arm (2) while rotating rear wiper blade (1) in the direction indicated by the arrow as shown in the figure.

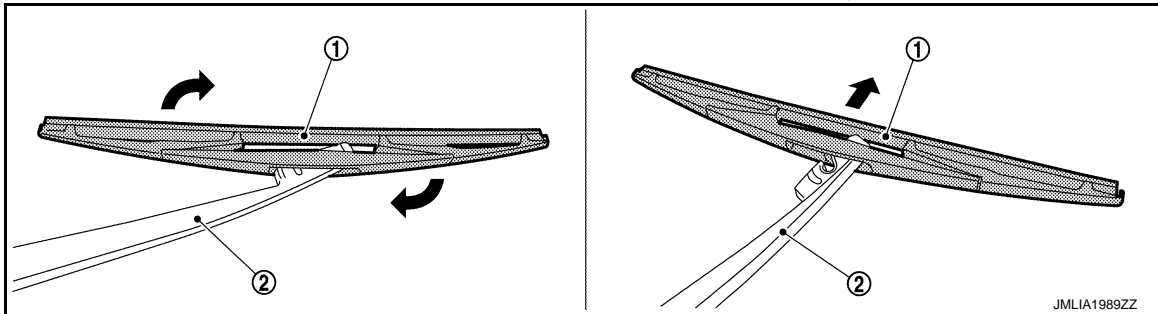

CAUTION:

Wrap wiper arm using a shop cloth so that wiper blade does not damage back door window glass.

INSTALLATION

Install in the reverse order of removal.

WIPER REFILL

WIPER REFILL : Removal and Installation

INFOID:000000008378025

REMOVAL

1. Remove rear wiper blade from the rear wiper arm. Refer to [WW-50, "WIPER BLADE : Removal and Installation"](#).
2. Remove rear wiper refill (2) from the end portion of rear wiper blade (1) in the direction indicated by the arrow as shown in the figure. Remove rear wiper refill while sliding it sideward.

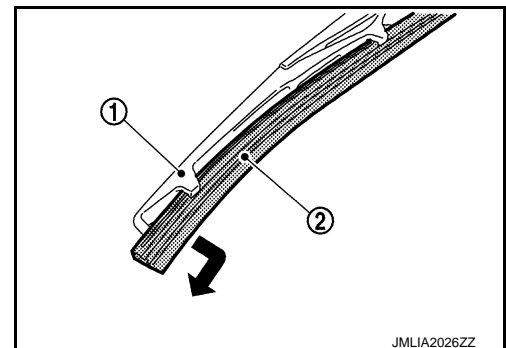

INSTALLATION

Note the following items, and then install in the reverse order of removal.

CAUTION:

- For installation of wiper refill, check that wiper refill is not twisted while installing.
- Check that wiper refill is inserted normally from the correct direction.

WIPER MOTOR

WIPER MOTOR : Removal and Installation

INFOID:000000008378026

REMOVAL

1. Remove rear wiper arm. Refer to [WW-48, "WIPER ARM : Removal and Installation"](#).
2. Remove back door lower finisher. Refer to [INT-47, "BACK DOOR LOWER FINISHER : Removal and Installation"](#).
3. Disconnect rear wiper motor harness connector.
4. Remove rear wiper motor mounting nut.
5. Raise rear wiper motor, and remove rear wiper motor from the vehicle.

CAUTION:

Never drop rear wiper motor or cause it to come into contact with other parts.

REAR WIPER

< REMOVAL AND INSTALLATION >

6. Remove pivot seal from the back door.

INSTALLATION

Install in the reverse order of removal.

A

B

C

D

E

F

G

H

I

J

K

WW

M

N

O

P

WASHER TANK

< REMOVAL AND INSTALLATION >

WASHER TANK

Exploded View

INFOID:000000008378027

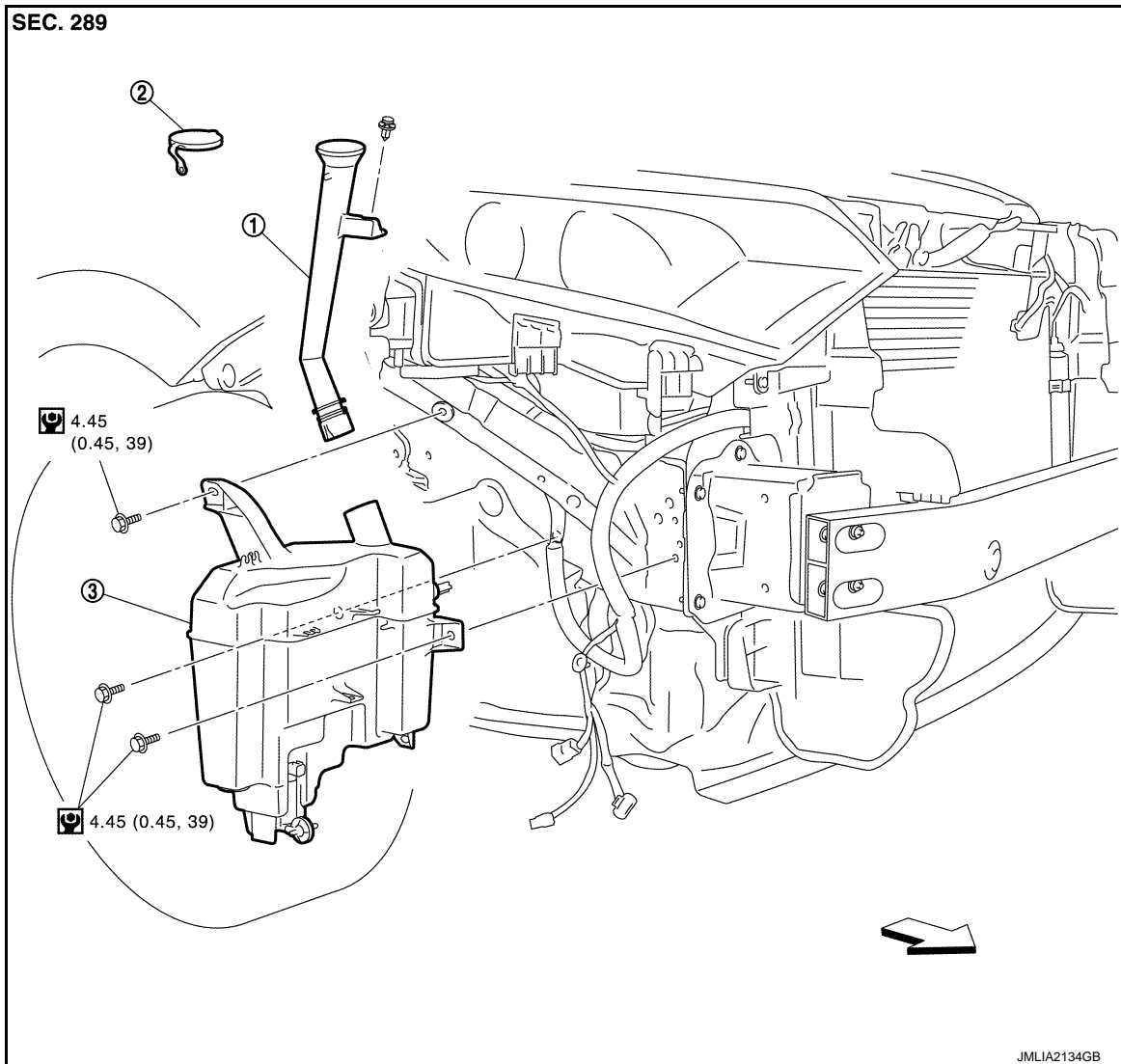

1. Washer tank inlet

2. Washer tank inlet cap

3. Washer tank assembly

 : N·m (kg·m, in·lb)

 : Vehicle front

Removal and Installation

INFOID:000000008378028

REMOVAL

1. Fully open hood assembly.

WASHER TANK

< REMOVAL AND INSTALLATION >

2. Remove washer tank inlet fixing clip (A).
3. Pull out washer tank inlet (1) from the washer tank.

← : Vehicle front

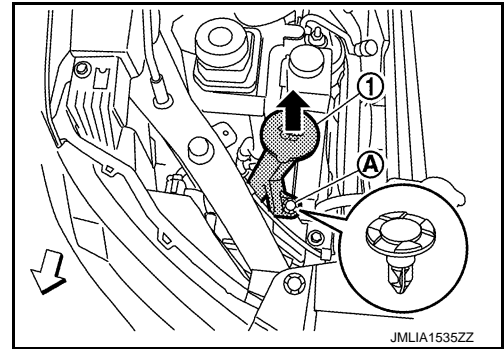

4. Remove fender protector RH (front). Refer to [EXT-22. "Removal and Installation"](#).
5. Disconnect washer pump connector (A) and washer level switch connector (B).
6. Remove harness fixing clips (C) from the washer tank (1).
7. Disconnect front washer tube (3) and rear washer tube (4) from the front & rear washer pump (2).

○ : Clip

← : Vehicle front

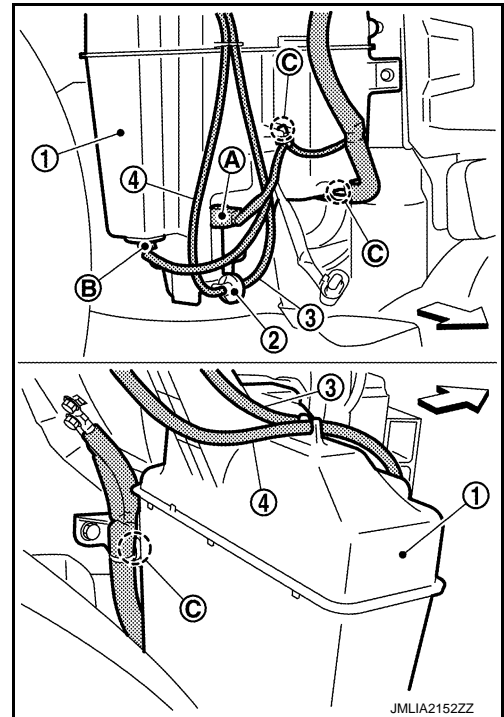

8. Remove washer tank mounting bolts.
9. Remove washer tank from the vehicle.

INSTALLATION

Note the following items, and then install in the reverse order of removal.

CAUTION:

- When installing tube to front & rear washer pump, be sure to install to front and rear correctly.
- Add water up to the top of the washer tank inlet after installing. Check that there is no leakage.

A
B
C
D
E
F
G
H
I
J
K
M
N
O
P

WW

WASHER PUMP

< REMOVAL AND INSTALLATION >

WASHER PUMP

Exploded View

INFOID:000000008378029

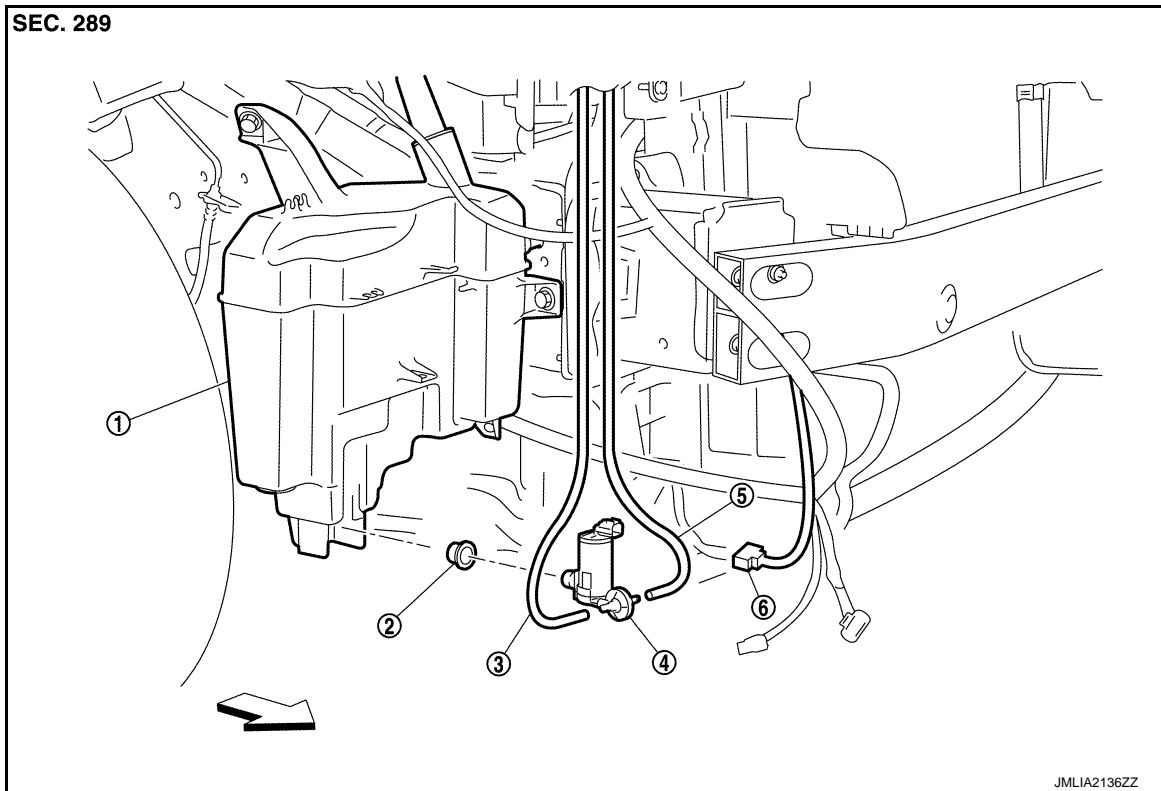

- | | | |
|-----------------------------|----------------------|--------------------------|
| 1. Washer tank | 2. Packing | 3. Rear washer tube |
| 4. Front & rear washer pump | 5. Front washer tube | 6. Washer pump connector |

⇐ : Vehicle front

Removal and Installation

INFOID:000000008378030

REMOVAL

1. Remove fender protector RH (front). Refer to [EXT-22. "Removal and Installation"](#).
2. Disconnect washer pump connector (A).
3. Disconnect front washer tube (3) and rear washer tube (4) from the front & rear washer pump (2).
4. Remove washer pump from the washer tank (1).

⇐ : Vehicle front

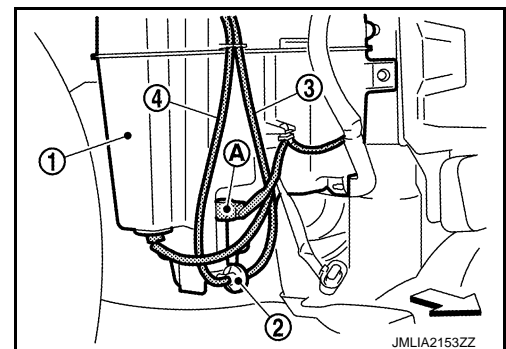

5. Remove packing from the washer tank.

INSTALLATION

Note the following items, and then install in the reverse order of removal.

CAUTION:

- When installing tube to front & rear washer pump, be sure to install to front and rear correctly.
- Check that there is no leakage after installation or replace packing with new part if it has been damaged.

WASHER PUMP

< REMOVAL AND INSTALLATION >

- **Never twist the packing when installing the washer pump.**

A

B

C

D

E

F

G

H

I

J

K

WW

M

N

O

P

WASHER NOZZLE & TUBE

< REMOVAL AND INSTALLATION >

WASHER NOZZLE & TUBE

Exploded View

INFOID:000000008378031

FRONT WASHER NOZZLE & TUBE

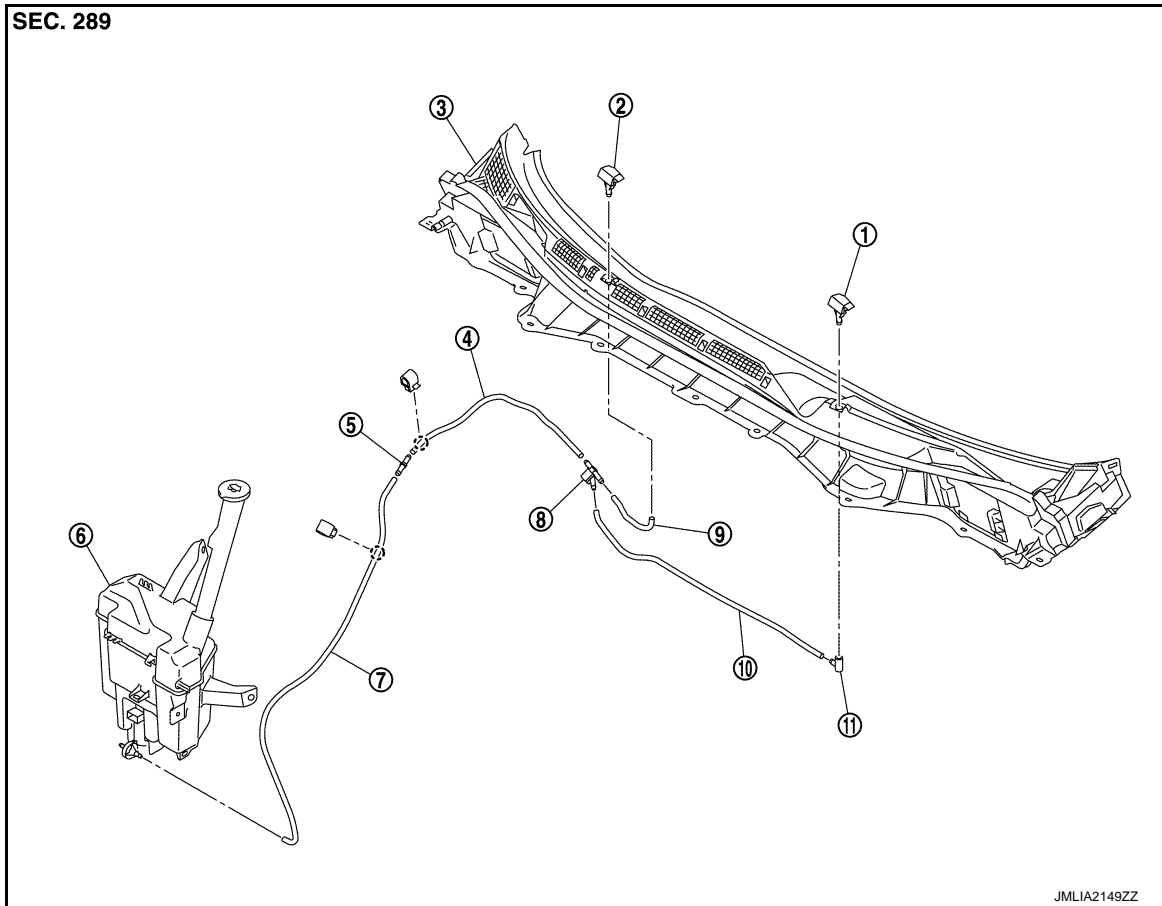

- | | | |
|---------------------------|---------------------------|-------------------------|
| 1. Front washer nozzle LH | 2. Front washer nozzle RH | 3. Cowl top cover |
| 4. Front washer tube B | 5. Joint A | 6. Washer tank assembly |
| 7. Front washer tube A | 8. Check valve | 9. Front washer tube C |
| 10. Front washer tube D | 11. Joint B | |

○ : Clip

REAR WASHER NOZZLE & TUBE

WASHER NOZZLE & TUBE

< REMOVAL AND INSTALLATION >

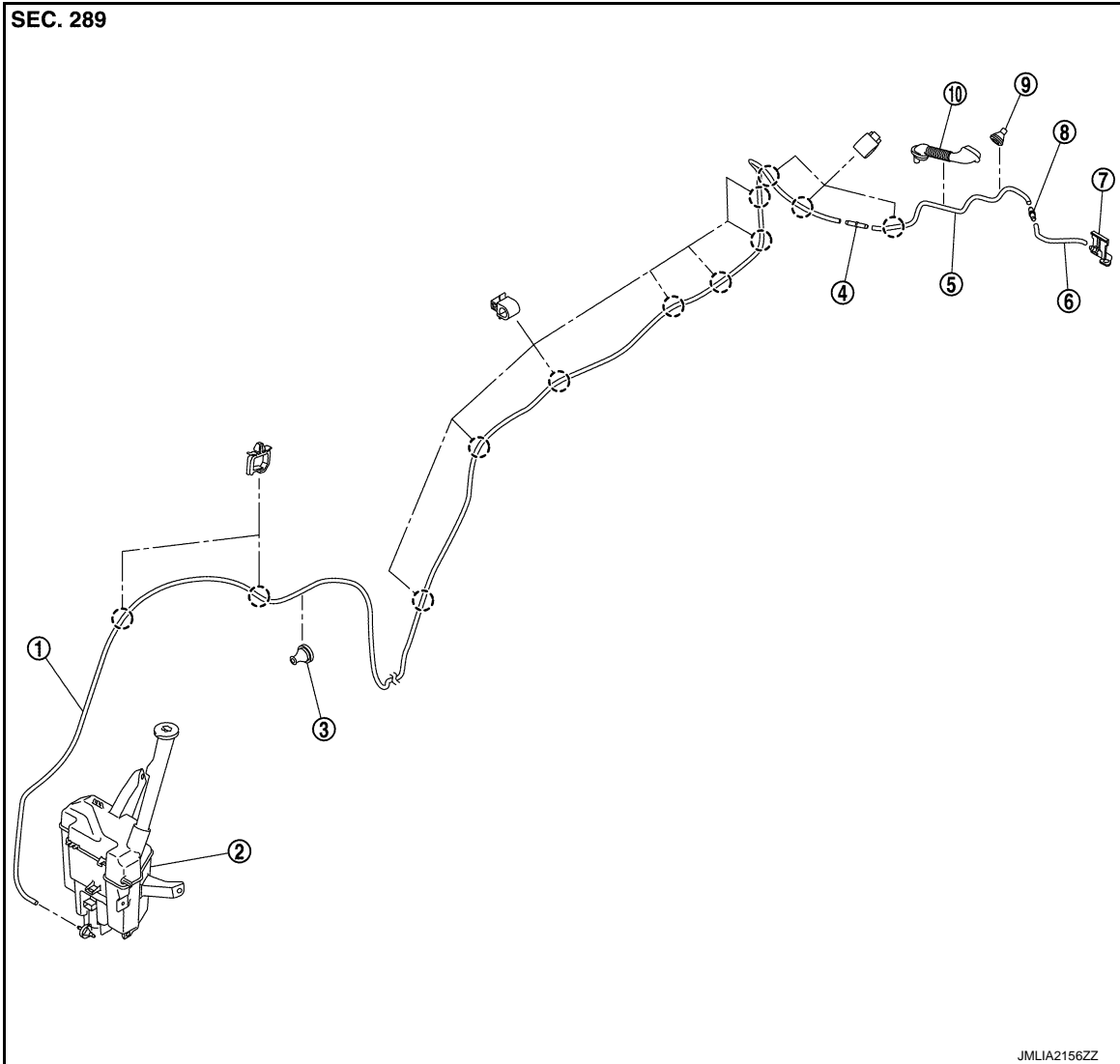

- | | | |
|---------------------------|-------------------------|-----------------------|
| 1. Rear washer tube A | 2. Washer tank assembly | 3. Grommet A |
| 4. Joint A | 5. Rear washer tube B | 6. Rear washer tube C |
| 7. Rear washer nozzle | 8. Joint B | 9. Grommet B |
| 10. Back door seal rubber | | |

⊖ : Clip

A
B
C
D
E
F
G
H
I
J
K

WW

M
N
O
P

WASHER NOZZLE & TUBE

< REMOVAL AND INSTALLATION >

Hydraulic Layout

INFOID:000000008378032

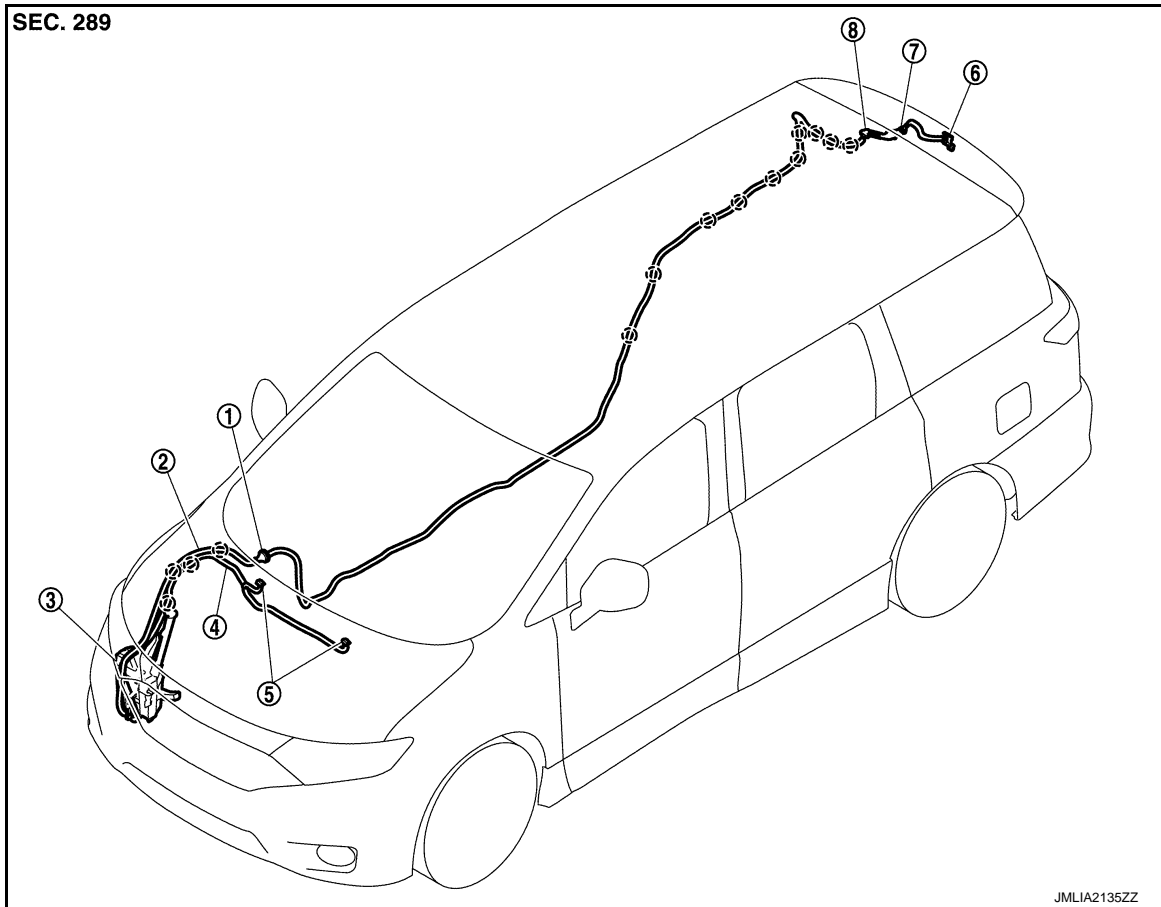

- | | | |
|----------------------|--------------------------|-------------------------|
| 1. Grommet A | 2. Rear washer tube | 3. Washer tank assembly |
| 4. Front washer tube | 5. Front washer nozzle | 6. Rear washer nozzle |
| 7. Grommet B | 8. Back door seal rubber | |

 : Clip

WASHER NOZZLE

WASHER NOZZLE : Removal and Installation

INFOID:000000008378033

FRONT WASHER NOZZLE

REMOVAL

1. Remove cowl top cover. Refer to [EXT-21, "Removal and Installation"](#).
2. Disconnect front washer tube (3) from the front washer nozzle (1).
3. Press front washer nozzle fixing pawls toward the direction shown by the arrows 2 and pull up remove from cowl top cover (2).

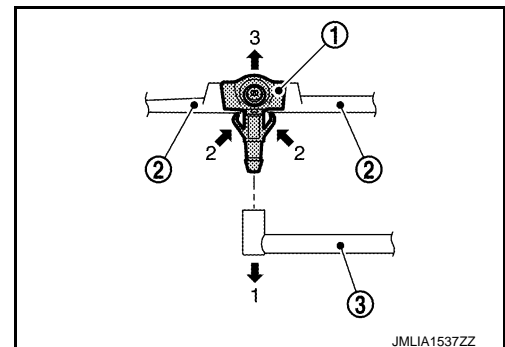

INSTALLATION

Note the following items, and then install in the reverse order of removal.

WASHER NOZZLE & TUBE

< REMOVAL AND INSTALLATION >

CAUTION:

- The spray positions differ, check that left and right nozzles are installed correctly.
- Adjust the washer nozzle spray position. Refer to [WW-59, "WASHER NOZZLE : Inspection and Adjustment"](#).

REAR WASHER NOZZLE

REMOVAL

1. Remove rear spoiler. Refer to [EXT-44, "Removal and Installation"](#).
2. Remove high-mounted stop lamp.
 - Xenon type: Refer to [EXL-104, "Removal and Installation"](#).
 - Halogen type: Refer to [EXL-201, "Removal and Installation"](#).
3. Press rear washer nozzle fixing pawls (A) toward the direction shown by the arrows and remove from rear spoiler (1).

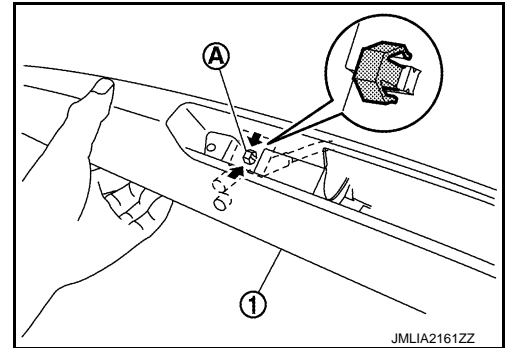

4. Disconnect front washer tube from the front washer nozzle.

INSTALLATION

Note the following items, and then install in the reverse order of removal.

CAUTION:

- Adjust the washer nozzle spray position. Refer to [WW-59, "WASHER NOZZLE : Inspection and Adjustment"](#).

WASHER NOZZLE : Inspection and Adjustment

INFOID:000000008378034

INSPECTION

FRONT CHECK VALVE INSPECTION

Check that air can pass through the hose by blowing forward (toward the nozzle), and check that air cannot pass through by sucking.

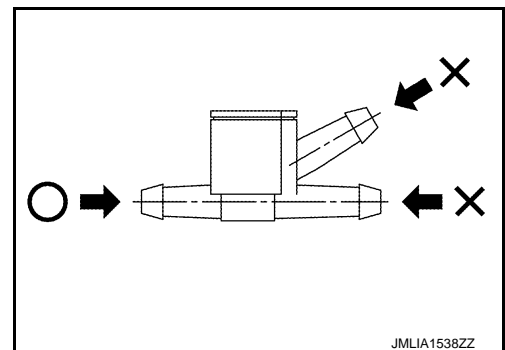

REAR CHECK VALVE INSPECTION

Check that air can pass through the hose by blowing forward (toward the nozzle), and check that air cannot pass through by sucking.

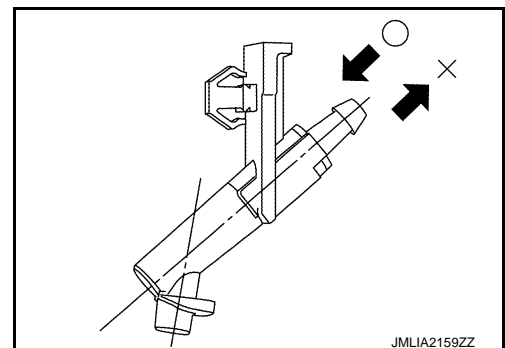

WASHER NOZZLE & TUBE

< REMOVAL AND INSTALLATION >

ADJUSTMENT

FRONT WASHER NOZZLE SPRAY POSITION ADJUSTMENT

Adjust spray positions to match the positions shown in the figure.

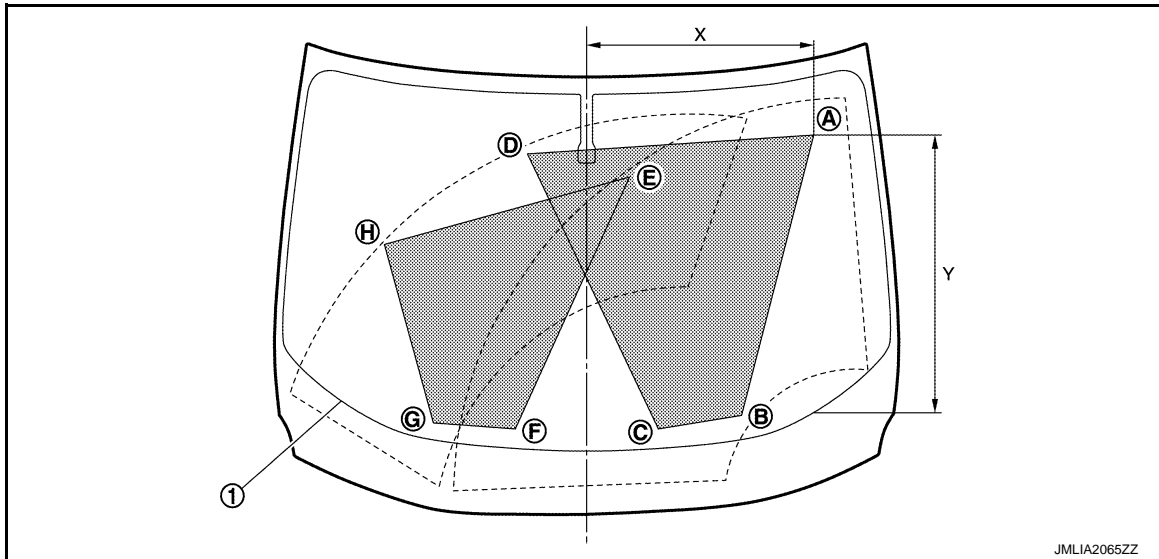

: Spray area

1. Black printed frame line

Unit: mm (in)

	Driver side				Passenger side			
	A	B	C	D	E	F	G	H
X	578 (22.76)	381 (15.00)	181 (7.13)	129 (5.08)	88 (3.46)	169 (6.65)	366 (14.41)	484 (19.06)
Y	638 (14.49)	62 (2.44)	56 (2.20)	703 (27.68)	674 (26.54)	49 (1.93)	61 (2.40)	504 (19.84)

Check that washer fluid is splayed on 70% or more the splay area () when spraying washer fluid. If the spray area deviates from the specification, adjust the washer nozzle.

CAUTION:

- Use washer nozzle adjuster (A) for nozzle (1) insert adjustment if the jet a is outside the angle.
- Never use needle or small pin.

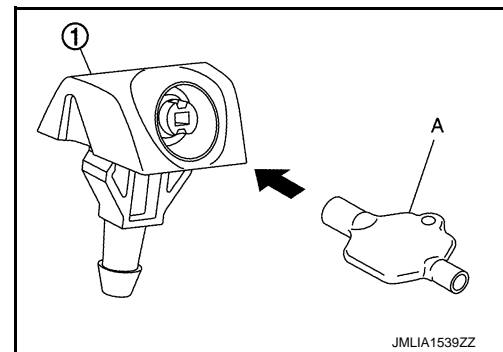

NOTE:

If wax or dust gets into the nozzle, remove wax or dust with a needle or small pin.

REAR WASHER NOZZLE SPRAY POSITION ADJUSTMENT

Adjust spray positions to match the positions shown in the figure.

WASHER NOZZLE & TUBE

< REMOVAL AND INSTALLATION >

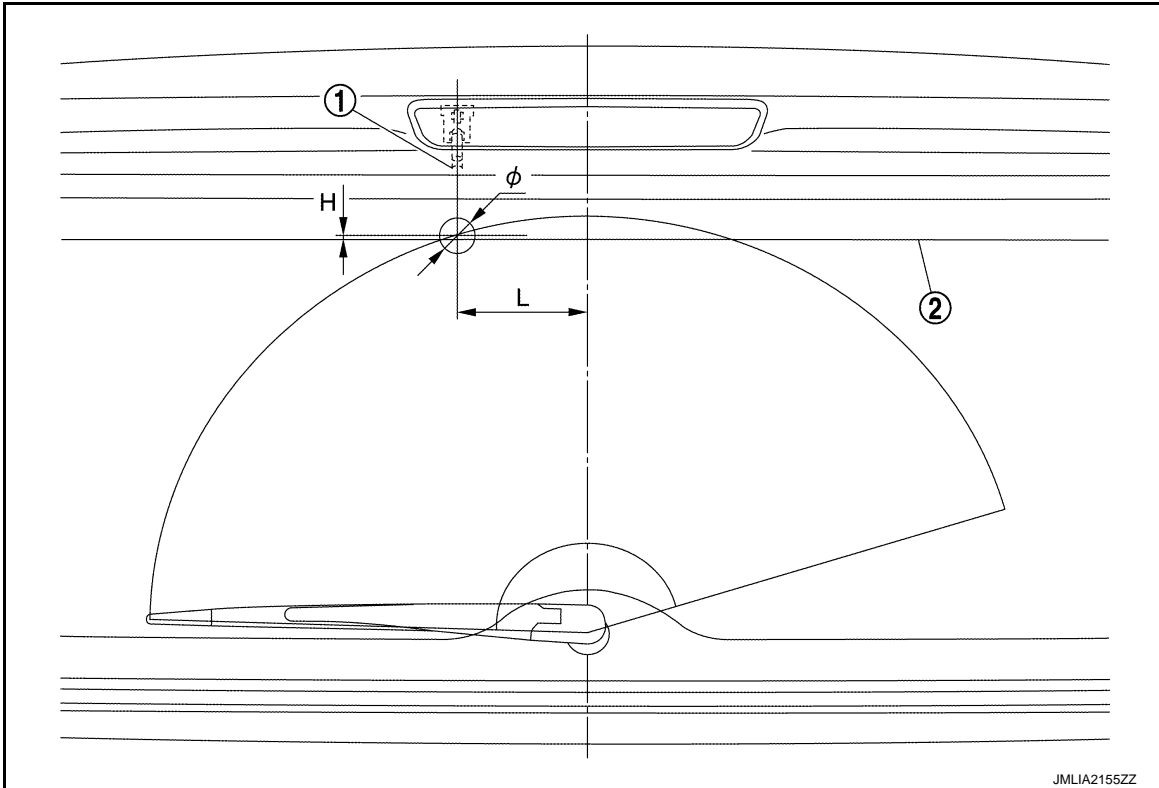

- 1. Rear washer nozzle
- 2. Black print frame line

Unit: mm (in)

H : Height	L : Length	φ : Spray position area
3.0 (0.118)	115.0 (4.528)	30 (1.181)

Insert a needle or similar object (A) into the spray opening (1) and move up/down and left/right to adjust the spray position.

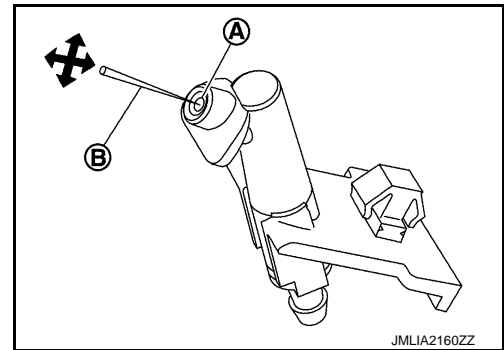

NOTE:

If wax or dust gets into the nozzle, remove wax or dust with a needle or small pin.

WASHER TUBE

WASHER TUBE : Removal and Installation

INFOID:0000000008378035

FRONT WASHER TUBE

REMOVAL

1. Fully open hood assembly.
2. Remove fender protector RH (front). Refer to [EXT-22, "Removal and Installation"](#).
3. Disconnect front washer tub A from the front & rear washer pump.

WASHER NOZZLE & TUBE

< REMOVAL AND INSTALLATION >

4. Disconnect front washer tube A (1) from joint A (2).
5. Remove front washer tube mounting clips (A) from the Vehicle.
6. Remove front washer tube mounting clips from front washer tube A and B (3).
7. Remove front washer tube A from the vehicle.

⇐ : Vehicle front

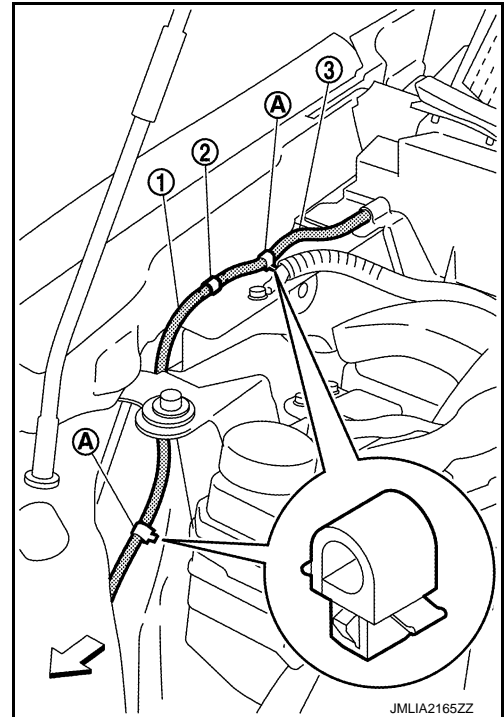

JMLIA2165ZZ

8. Remove cowl top cover. Refer to [EXT-21, "Removal and Installation"](#).
9. Disconnect front washer tube C and D from the front washer nozzle. Refer to [WW-58, "WASHER NOZZLE : Removal and Installation"](#).
10. Remove front washer tube B.
 - a. Disconnect front washer tube B from the cowl top cover.
 - b. Disconnect front washer tube B check valve.
11. Remove front washer tube C.
 - a. Disconnect front washer tube C from the cowl top cover.
 - b. Disconnect front washer tube C check valve.
12. Remove front washer tube D.
 - a. Disconnect front washer tube D from the cowl top cover.
 - b. Disconnect front washer tube D check valve.

INSTALLATION

Note the following item, and then install in the reverse order of removal.

CAUTION:

- When installing front washer tube C to the check valve, install to portion (B: RH side).
- When installing front washer tube D to the check valve, install to portion (A: LH side).

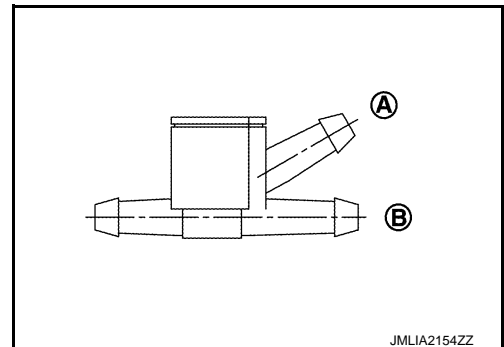

JMLIA2154ZZ

REAR WASHER TUBE

REMOVAL

1. Fully open hood assembly.
2. Remove fender protector RH (front). Refer to [EXT-22, "Removal and Installation"](#).
3. Disconnect rear washer tube A from the front & rear washer pump.

WASHER NOZZLE & TUBE

< REMOVAL AND INSTALLATION >

4. Remove front kicking plate and rear kicking plate. Refer to [INT-21. "KICKING PLATE : Removal and Installation"](#).
5. Remove luggage side lower finisher and back pillar garnish. Refer to [INT-26. "BACK PILLAR GARNISH : Removal and Installation"](#).
6. Remove third assist grip (LH and RH), and then remove headlining assembly rear clips. Refer to [INT-34. "Removal and Installation"](#).
7. Slightly lower the headlining assembly (1) rear and secure work space.
8. Disconnect rear washer tube B (3) from joint B (2).

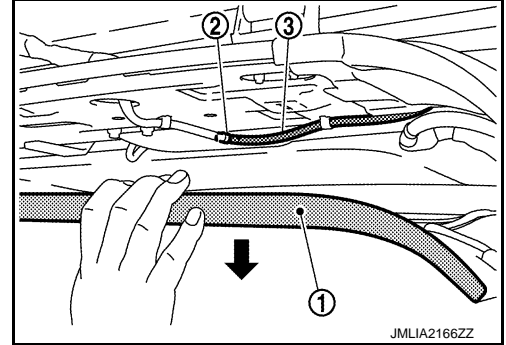

9. Remove back door upper finisher. Refer to [INT-48. "BACK DOOR UPPER FINISHER : Removal and Installation"](#).
10. Disconnect rear washer tube C from the rear washer nozzle. Refer to [WW-58. "WASHER NOZZLE : Removal and Installation"](#).
11. Remove rear washer tube mounting clips (A) from the Vehicle.
12. Remove rear washer tube mounting clips from the rear washer tube.
13. Remove rear washer tube from the vehicle.

INSTALLATION

Install in the reverse order of removal.

A
B
C
D
E
F
G
H
I
J
K
L
M
N
O
P

WW

WASHER LEVEL SWITCH

< REMOVAL AND INSTALLATION >

WASHER LEVEL SWITCH

Removal and Installation

INFOID:000000008378036

The washer level switch must be replaced together with the washer tank as an assembly.
Refer to [WW-52. "Removal and Installation"](#).

WIPER AND WASHER SWITCH

< REMOVAL AND INSTALLATION >

WIPER AND WASHER SWITCH

Exploded View

INFOID:000000008378037

Refer to [BCS-87, "Exploded View"](#).

A

B

C

D

E

F

G

H

I

J

K

WW

M

N

O

P