

SECTION **CHG**  
CHARGING SYSTEM

A  
B  
C

CONTENTS

<b>PRECAUTION</b> .....	3	<b>BASIC INSPECTION</b> .....	14	F
<b>PRECAUTIONS</b> .....	3	<b>DIAGNOSIS AND REPAIR WORK FLOW</b> .....	14	G
Precaution for Supplemental Restraint System (SRS) "AIR BAG" and "SEAT BELT PRE-TENSIONER" .....	3	Work Flow (With EXP-800 NI or GR8-1200 NI) .....	14	
Precaution for Power Generation Voltage Variable Control System .....	3	Work Flow (Without EXP-800 NI or GR8-1200 NI).....	18	
Precautions for Removing Battery Terminal .....	3	<b>CHARGING SYSTEM PRELIMINARY INSPECTION</b> .....	21	H
<b>PREPARATION</b> .....	5	Inspection Procedure .....	21	
<b>PREPARATION</b> .....	5	<b>POWER GENERATION VOLTAGE VARIABLE CONTROL SYSTEM OPERATION INSPECTION</b> .....	22	I
Special Service Tools .....	5	Inspection Procedure .....	22	J
Commercial Service Tools .....	5	<b>DTC/CIRCUIT DIAGNOSIS</b> .....	24	
<b>SYSTEM DESCRIPTION</b> .....	6	<b>B TERMINAL CIRCUIT</b> .....	24	K
<b>COMPONENT PARTS</b> .....	6	Description .....	24	
<b>CHARGING SYSTEM</b> .....	6	Diagnosis Procedure .....	24	
CHARGING SYSTEM : Component Parts Location .....	6	<b>L TERMINAL CIRCUIT (OPEN)</b> .....	25	L
<b>POWER GENERATION VOLTAGE VARIABLE CONTROL SYSTEM</b> .....	6	Description .....	25	
POWER GENERATION VOLTAGE VARIABLE CONTROL SYSTEM : Component Parts Location.....	6	Diagnosis Procedure .....	25	
<b>SYSTEM</b> .....	8	<b>L TERMINAL CIRCUIT (SHORT)</b> .....	27	
<b>CHARGING SYSTEM</b> .....	8	Description .....	27	
CHARGING SYSTEM : System Description .....	8	Diagnosis Procedure .....	27	
<b>POWER GENERATION VOLTAGE VARIABLE CONTROL SYSTEM</b> .....	8	<b>S TERMINAL CIRCUIT</b> .....	28	
POWER GENERATION VOLTAGE VARIABLE CONTROL SYSTEM : System Description .....	8	Description .....	28	
<b>WIRING DIAGRAM</b> .....	10	Diagnosis Procedure .....	28	O
<b>CHARGING SYSTEM</b> .....	10	<b>SYMPTOM DIAGNOSIS</b> .....	29	
Wiring Diagram .....	10	<b>CHARGING SYSTEM</b> .....	29	P
		Symptom Table .....	29	
		<b>REMOVAL AND INSTALLATION</b> .....	30	
		<b>ALTERNATOR</b> .....	30	
		Exploded View .....	30	
		Removal and Installation .....	31	

D  
E

F

G

H

I

J

K

L

CHG

N

O

P

---

Inspection ..... 32

**SERVICE DATA AND SPECIFICATIONS  
(SDS) ..... 33**

**SERVICE DATA AND SPECIFICATIONS  
(SDS) ..... 33**

Alternator ..... 33

# PRECAUTIONS

< PRECAUTION >

## PRECAUTION

### PRECAUTIONS

#### Precaution for Supplemental Restraint System (SRS) "AIR BAG" and "SEAT BELT PRE-TENSIONER"

INFOID:000000009650413

The Supplemental Restraint System such as "AIR BAG" and "SEAT BELT PRE-TENSIONER", used along with a front seat belt, helps to reduce the risk or severity of injury to the driver and front passenger for certain types of collision. This system includes seat belt switch inputs and dual stage front air bag modules. The SRS system uses the seat belt switches to determine the front air bag deployment, and may only deploy one front air bag, depending on the severity of a collision and whether the front occupants are belted or unbelted. Information necessary to service the system safely is included in the "SRS AIR BAG" and "SEAT BELT" of this Service Manual.

#### **WARNING:**

Always observe the following items for preventing accidental activation.

- To avoid rendering the SRS inoperative, which could increase the risk of personal injury or death in the event of a collision that would result in air bag inflation, all maintenance must be performed by an authorized NISSAN/INFINITI dealer.
- Improper maintenance, including incorrect removal and installation of the SRS, can lead to personal injury caused by unintentional activation of the system. For removal of Spiral Cable and Air Bag Module, see "SRS AIR BAG".
- Never use electrical test equipment on any circuit related to the SRS unless instructed to in this Service Manual. SRS wiring harnesses can be identified by yellow and/or orange harnesses or harness connectors.

#### PRECAUTIONS WHEN USING POWER TOOLS (AIR OR ELECTRIC) AND HAMMERS

#### **WARNING:**

Always observe the following items for preventing accidental activation.

- When working near the Air Bag Diagnosis Sensor Unit or other Air Bag System sensors with the ignition ON or engine running, never use air or electric power tools or strike near the sensor(s) with a hammer. Heavy vibration could activate the sensor(s) and deploy the air bag(s), possibly causing serious injury.
- When using air or electric power tools or hammers, always switch the ignition OFF, disconnect the battery, and wait at least 3 minutes before performing any service.

#### Precaution for Power Generation Voltage Variable Control System

INFOID:0000000009650414

#### **CAUTION:**

For model with power generation voltage variable control system, the battery current sensor that is installed to the battery cable at the negative terminal measures the charging/discharging current of the battery, and performs various controls. If the electrical component or the ground wire is connected directly to the battery terminal, the current other than that being measured with the battery current sensor is charging to or discharging from the battery. This condition causes the malfunction of the control, and then the battery discharge may occur. Do not connect the electrical component or the ground wire directly to the battery terminal.

#### Precautions for Removing Battery Terminal

INFOID:0000000009956689

- When removing the 12V battery terminal, turn OFF the ignition switch and wait at least 30 seconds.

#### **NOTE:**

ECU may be active for several tens of seconds after the ignition switch is turned OFF. If the battery terminal is removed before ECU stops, then a DTC detection error or ECU data corruption may occur.

- For vehicles with the 2-batteries, be sure to connect the main battery and the sub battery before turning ON the ignition switch.

#### **NOTE:**

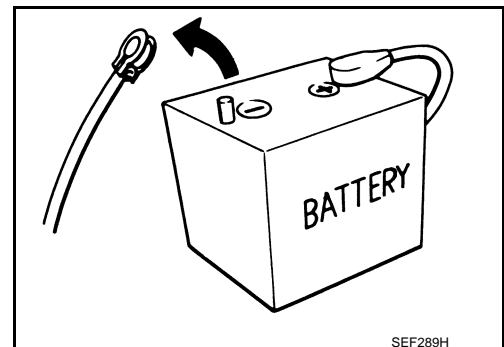

SEF289H

## PRECAUTIONS

### < PRECAUTION >

---

If the ignition switch is turned ON with any one of the terminals of main battery and sub battery disconnected, then DTC may be detected.

- After installing the 12V battery, always check "Self Diagnosis Result" of all ECUs and erase DTC.

**NOTE:**

The removal of 12V battery may cause a DTC detection error.

# PREPARATION

< PREPARATION >

## PREPARATION

### PREPARATION

#### Special Service Tools

INFOID:000000009650415

Tool number (Kent-Moore No.) Tool name	Description
<p>— (—) Model GR8-1200 NI Multitasking battery and electrical diagnostic station</p>	<p>Tests batteries, starting and charging systems and charges batteries. For operating instructions, refer to diagnostic station instruction manual.</p>
<p>— (—) Model EXP-800 NI Battery and electrical diagnostic analyzer</p>	<p>Tests batteries and charging systems. For operating instructions, refer to diagnostic analyzer instruction manual.</p>

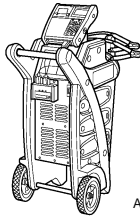

AWI1A1239ZZ

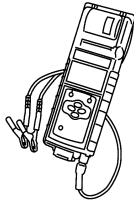

JSMIA0806ZZ

#### Commercial Service Tools

INFOID:000000009650416

Tool name	Description
<p>Power tool</p>	<p>Loosening bolts, nuts and screws</p>



PIIB1407E

A  
B  
C  
D  
E  
F  
G  
H  
I  
J  
K  
L

**CHG**

## COMPONENT PARTS

< SYSTEM DESCRIPTION >

# SYSTEM DESCRIPTION

## COMPONENT PARTS

### CHARGING SYSTEM

#### CHARGING SYSTEM : Component Parts Location

INFOID:000000009650417

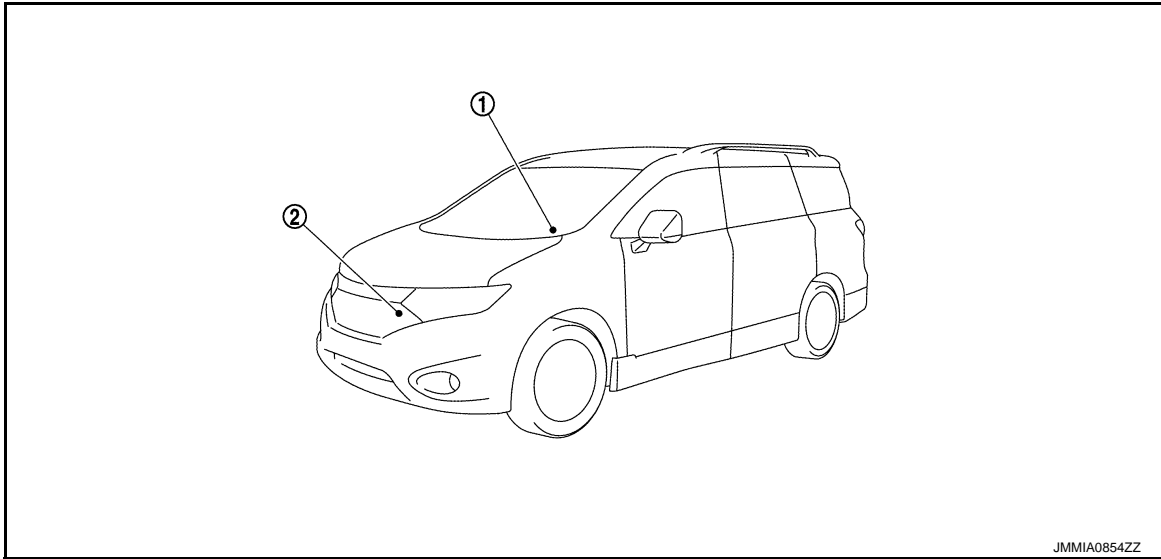

No.	Component part	Description
1.	Combination meter (Charge warning lamp)	The IC voltage regulator warning function activates to illuminate the charge warning lamp, if any of the following symptoms occur while alternator is operating: <ul style="list-style-type: none"> <li>• Excessive voltage is produced.</li> <li>• No voltage is produced.</li> </ul>
2.	Alternator	Refer to <a href="#">CHG-24, "Description"</a> .
		“B” terminal
		Refer to <a href="#">CHG-28, "Description"</a> .
		“S” terminal
		Refer to <a href="#">CHG-25, "Description"</a> .
		“L” terminal

## POWER GENERATION VOLTAGE VARIABLE CONTROL SYSTEM

### POWER GENERATION VOLTAGE VARIABLE CONTROL SYSTEM : Component

# COMPONENT PARTS

< SYSTEM DESCRIPTION >

## Parts Location

INFOID:000000009650418

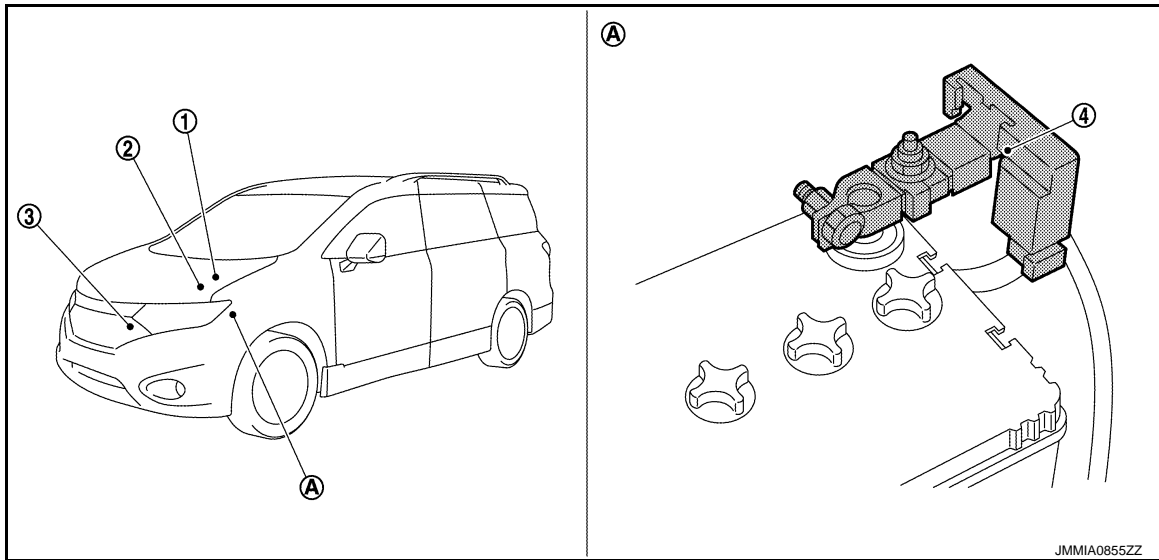

### A. Battery

No.	Component part	Description
1.	IPDM E/R	IPDM E/R converts the received power generation command value into the power generation command signal (PWM signal) and sends it to the IC voltage regulator. Refer to <a href="#">PCS-4, "IPDM E/R : Component Parts Location"</a> .
2.	ECM	Battery current sensor detects the charging/discharging current of the battery. ECM judges the battery condition based on this signal. ECM judges whether to perform the power generation voltage variable control according to the battery condition. When performing the power generation voltage variable control, ECM calculates the target power generation voltage according to the battery condition and sends the calculated value as the power generation command value signal to IPDM E/R. Refer to <a href="#">EC-15, "ENGINE CONTROL SYSTEM : Component Parts Location"</a> .
3.	Alternator (IC voltage regulator)	IC voltage regulator controls the power generation voltage by the target power generation voltage based on the received power generation command signal. When there is no power generation command signal, the alternator performs the normal power generation according to the characteristic of the IC voltage regulator.
4.	Battery current sensor (with battery temperature sensor)	Battery current sensor is installed to the battery cable at the negative terminal, and it detects the charging/discharging current of the battery and sends the voltage signal to ECM according to the current value.

A  
B  
C  
D  
E  
F  
G  
H  
I  
J  
K  
L  
N  
O  
P

CHG

# SYSTEM

< SYSTEM DESCRIPTION >

## SYSTEM

### CHARGING SYSTEM

#### CHARGING SYSTEM : System Description

INFOID:000000009650419

#### SYSTEM DIAGRAM

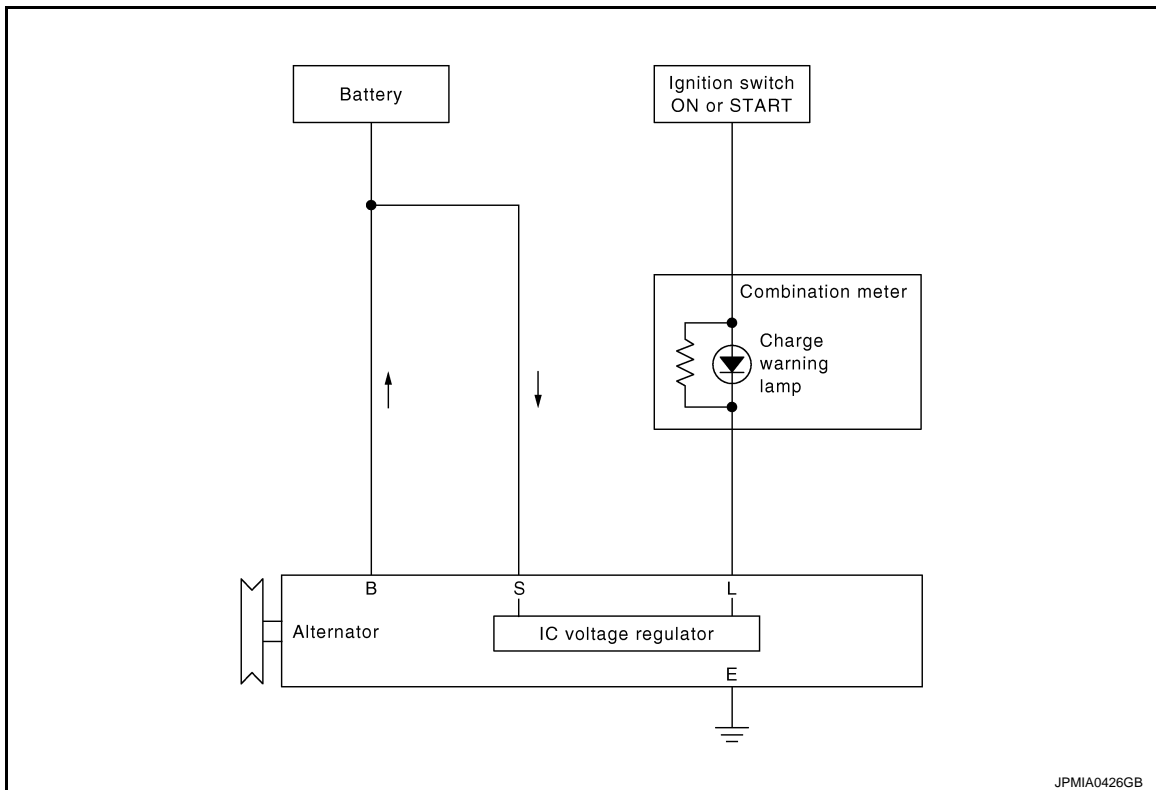

#### OUTLINE

The alternator provides DC voltage to operate the vehicle's electrical system and to keep the battery charged. The voltage output is controlled by the IC voltage regulator.

### POWER GENERATION VOLTAGE VARIABLE CONTROL SYSTEM

#### POWER GENERATION VOLTAGE VARIABLE CONTROL SYSTEM : System Description

INFOID:000000009650420

#### SYSTEM DIAGRAM

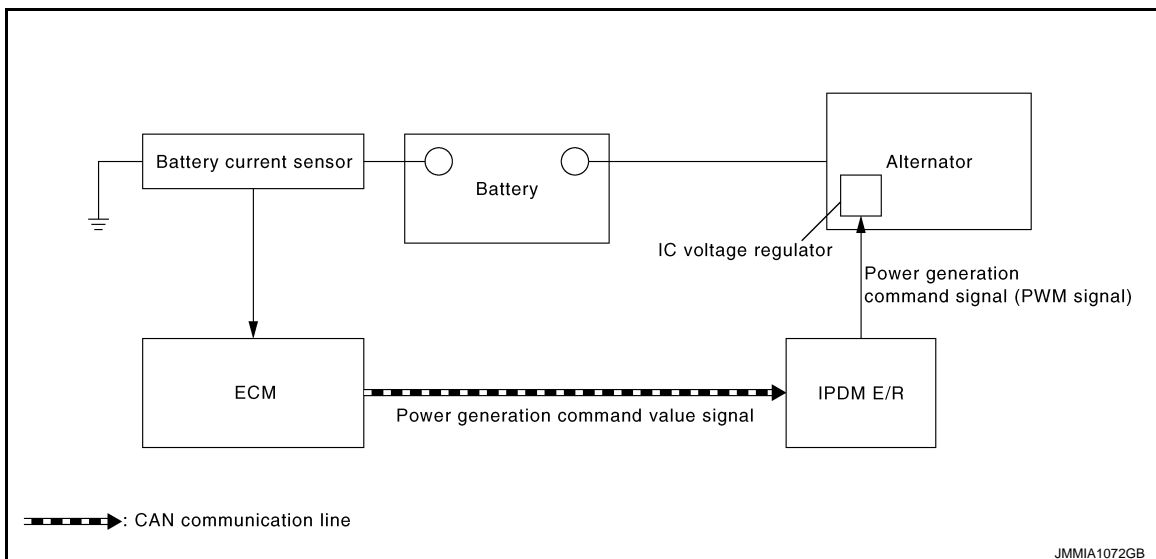



# SYSTEM

## < SYSTEM DESCRIPTION >

---

### OUTLINE

By performing the power generation voltage variable control, the engine load due to the power generation of the alternator is reduced and fuel consumption is decreased.

#### **NOTE:**

When any malfunction is detected in the power generation voltage variable control system, the power generation is performed according to the characteristic of the IC voltage regulator of the alternator.

A

B

C

D

E

F

G

H

I

J

K

L

CHG

N

O

P

# CHARGING SYSTEM

< WIRING DIAGRAM >

## WIRING DIAGRAM

### CHARGING SYSTEM

Wiring Diagram

INFOID:000000009650421

#### CHARGING SYSTEM

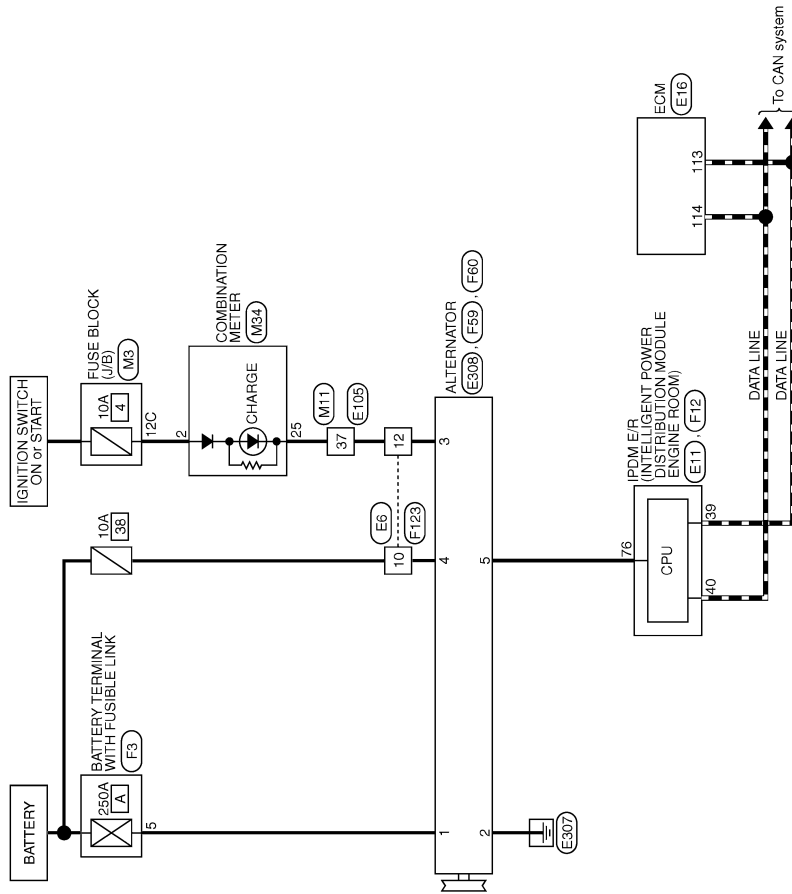

2010/12/13

JCMWA7679GB

# CHARGING SYSTEM

< WIRING DIAGRAM >

## CHARGING SYSTEM

Connector No.	E5
Connector Name	WIRE TO WIRE
Connector Type	TK16M3Y-TV

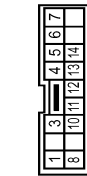

Terminal No.	Color Of Wire	Signal Name [Specification]
1	V	
2	Y	
3	LG	
4	GR	
5	GR	
6	V	
7	G	
8	P	
10	W	
11	G	
12	BR	
13	SB	
14	B	

Connector No.	E11
Connector Name	WIRE TO WIRE (WIRE TO WIRE) POWER DISTRIBUTION MODULE ENGINE ROOM
Connector Type	TH08FW-HH



Terminal No.	Color Of Wire	Signal Name [Specification]
39	P	
40	B	
41	B	
42	SB	
43	LG	
44	W	
45	Y	

46	O	--
----	---	----

Connector No.	E16
Connector Name	ECM
Connector Type	RH24FGY-RZ8-L-LH

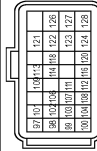

Terminal No.	Color Of Wire	Signal Name [Specification]
97	W	ACCELERATOR PEDAL POSITION SENSOR 1
98	O	ACCELERATOR PEDAL POSITION SENSOR 2
99	P	SENSOR POWER SUPPLY
100	B	SENSOR GROUND
101	Y	ASC/D STEERING SWITCH
102	LG	EVAP CONTROL SYSTEM PRESSURE SENSOR
103	GR	SENSOR POWER SUPPLY
104	LG	DATA LINK CONNECTOR
106	V	EVAP CANISTER VENT CONTROL VALVE
107	W	SENSOR POWER SUPPLY
108	BR	SENSOR GROUND
109	G	IGNITION SWITCH
110	V	FUEL PUMP RELAY
112	V	SENSOR GROUND
113	P	CAN COMMUNICATION LINE
114	L	CAN COMMUNICATION LINE
116	G	SENSOR GROUND
118	R	PNP signal
120	SB	SENSOR GROUND
121	L	POWER SUPPLY FOR ECM
122	SB	STOP LAMP SWITCH
123	B	ECM GROUND
124	B	ECM GROUND
126	BR	ASC/D BRAKE SWITCH
127	B	ECM GROUND
128	B	ECM GROUND

Connector No.	E105
Connector Name	WIRE TO WIRE
Connector Type	TH10MM-CS10-403

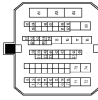

Terminal No.	Color Of Wire	Signal Name [Specification]
1	SHIELD	
2	W	
3	LG	
4	R	
6	LG	
7	R	
8	GR	
9	SB	
10	BR	
11	Y	
12	O	
13	W	
14	L	
15	P	
31	GR	
32	W	
33	W	
37	BR	
38	G	
39	V	
40	P	
41	L	
42	LG	
43	O	
45	GR	
46	SB	
47	V	
49	L	
51	BR	
52	G	
54	O	
55	Y	
56	SHIELD	
61	P	

Connector No.	E308
Connector Name	ALTERNATOR
Connector Type	E-LA8



Terminal No.	Color Of Wire	Signal Name [Specification]
2	B	
3	B	

A  
B  
C  
D  
E  
F  
G  
H  
I  
J  
K  
L  
N  
O  
P

CHG

JRMWE3347GB

# CHARGING SYSTEM

< WIRING DIAGRAM >

## CHARGING SYSTEM

Connector No.	F3
Connector Name	BATTERY TERMINAL WITH FUSIBLE LINK
Connector Type	24340-JA04D



Terminal No.	Color Of Wire	Signal Name [Specification]
3	B/R	-

Connector No.	F12
Connector Name	FROM SERVO/RELAY/ST POWER DISTRIBUTION MODULE ENGINE ROOM
Connector Type	TH20FW-CS12-AM

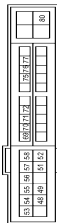

Terminal No.	Color Of Wire	Signal Name [Specification]
48	W	-
49	R/B	-
51	LG	-
52	Y/G	-
53	R/W	-
54	G/W	-
55	W/L	-
56	R/Y	-
57	O	-
58	Y	-
59	W/B	-
60	G	-
71	P	-
72	R/B	-
75	LG	-
76	GR	-
77	B	-
80	B	-

Connector No.	F5B
Connector Name	ALTERNATOR
Connector Type	24340-JA8A



Terminal No.	Color Of Wire	Signal Name [Specification]
1	B/R	-

Connector No.	F5B
Connector Name	ALTERNATOR
Connector Type	HS03FB



Terminal No.	Color Of Wire	Signal Name [Specification]
3	BR	-
4	Y/B	-
5	SB	-

Connector No.	F123
Connector Name	WIRE TO WIRE
Connector Type	TK18CY-1V



Terminal No.	Color Of Wire	Signal Name [Specification]
7	G/R	-
3	G/R	-
4	G/B	-
5	R	-
6	L/R	-
7	P	-
8	P	-
10	Y/B	-
11	BR/W	-
12	BR	-
13	G	-
14	B	-

Connector No.	M3
Connector Name	FUSE BLOCK (J/B)
Connector Type	NS12FW-GS

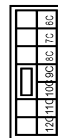

Terminal No.	Color Of Wire	Signal Name [Specification]
72	LG	-
73	Y	-
74	GR	-
75	GR	-
76	B/R	-
80	G	-
81	Y	-

Connector No.	M11
Connector Name	WIRE TO WIRE
Connector Type	TH20FW-CS10-M3



Terminal No.	Color Of Wire	Signal Name [Specification]
1	SHIELD	-
2	R	-
3	B	-
4	B	-
6	O	-
7	G	-
8	G	-
9	B	-
10	R	-
11	W	-
12	LG	-
13	Y	-
14	L	-
15	P	-
31	R	-
32	Y	-
33	Y	-
37	BR	-
38	BR	-
39	Y	-
40	P	-
41	L	-
42	G	-
43	W	-
45	LG	-
46	V	-
47	LG	-
49	G	-
51	SB	-
52	GR	-
53	R	-
54	B	-
55	L	-
56	SHIELD	-
61	BR	-
62	LG	-

# CHARGING SYSTEM

< WIRING DIAGRAM >

## CHARGING SYSTEM

83	W/L	--	--
84	RR	--	--
85	GR	--	--
86	CB	--	--
87	SB	--	--
88	Y	--	--
70	R	--	--
71	R	--	--
72	L	--	--
73	R	--	--
74	Y	--	--
75	G	--	--
76	V	--	--
77	P	--	--
78	W	--	--
80	Y	--	--
81	W	--	--
82	L	--	--
83	R	--	--

21	L	GAN-H
22	L	GAN-H
23	B	GROUND
24	B	GROUND
25	BR	FUEL LEVEL SENSOR SIGNAL
26	BR	FUEL LEVEL SENSOR GROUND
27	Y	ALTERNATOR SIGNAL
28	BR	PARKING BRAKE SWITCH SIGNAL
29	G	WASHER LEVEL SWITCH SIGNAL
30	V	SECURITY SIGNAL
31	SB	VEHICLE SPEED SIGNAL (8-PULSE)
32	P	OVERDRIVE CONTROL SWITCH SIGNAL
34	O	FUEL LEVEL SENSOR SIGNAL
35	P	SEAT BELT BUCKLE SWITCH SIGNAL DRIVER SIDE
36	BR	PASSENGER SEAT BELT WARNING SIGNAL

Connector No.	M34
Connector Name	COMBINATION METER
Connector Type	TH40FW-NH



1	2	3	4	5	6	7	8	9	10	11	12	13	14	15	16	17	18	19	20
---	---	---	---	---	---	---	---	---	----	----	----	----	----	----	----	----	----	----	----

Terminal No.	Wire	Signal Name [Specification]
1	G	BATTERY POWER SUPPLY
2	Y	IGNITION SIGNAL
3	B	GROUND
4	B	GROUND
5	B/P	ILLUMINATION CONTROL SIGNAL
8	SB	TRIP RESET SWITCH SIGNAL
10	P	METER CONTROL SWITCH GROUND
11	G	ENTER SWITCH SIGNAL
12	BR	SELECT SWITCH SIGNAL
13	P	ILLUMINATION CONTROL SWITCH SIGNAL (G)
14	V	ILLUMINATION CONTROL SWITCH SIGNAL (C)
15	BR	AIR BAG SIGNAL
16	L	ENGINE COOLANT TEMPERATURE SIGNAL
18	LG	AMBIENT SENSOR SIGNAL
19	R	A/C AUTO AMP CONNECTION RECOGNITION SIGNAL
20	Y	AMBIENT SENSOR GROUND

A  
B  
C  
D  
E  
F  
G  
H  
I  
J  
K  
L  
CHG  
N  
O  
P

JRMWE3349GB

## DIAGNOSIS AND REPAIR WORK FLOW

< BASIC INSPECTION >

---

### BASIC INSPECTION

#### DIAGNOSIS AND REPAIR WORK FLOW

Work Flow (With EXP-800 NI or GR8-1200 NI)

INFOID:000000009650422

#### CHARGING SYSTEM DIAGNOSIS WITH EXP-800 NI OR GR8-1200 NI

To test the charging system, use the following special service tools:

- EXP-800 NI Battery and electrical diagnostic analyzer
- GR8-1200 NI Multitasking battery and electrical diagnostic station

**NOTE:**

Refer to the applicable Instruction Manual for proper charging system diagnosis procedures.

# DIAGNOSIS AND REPAIR WORK FLOW

< BASIC INSPECTION >

OVERALL SEQUENCE

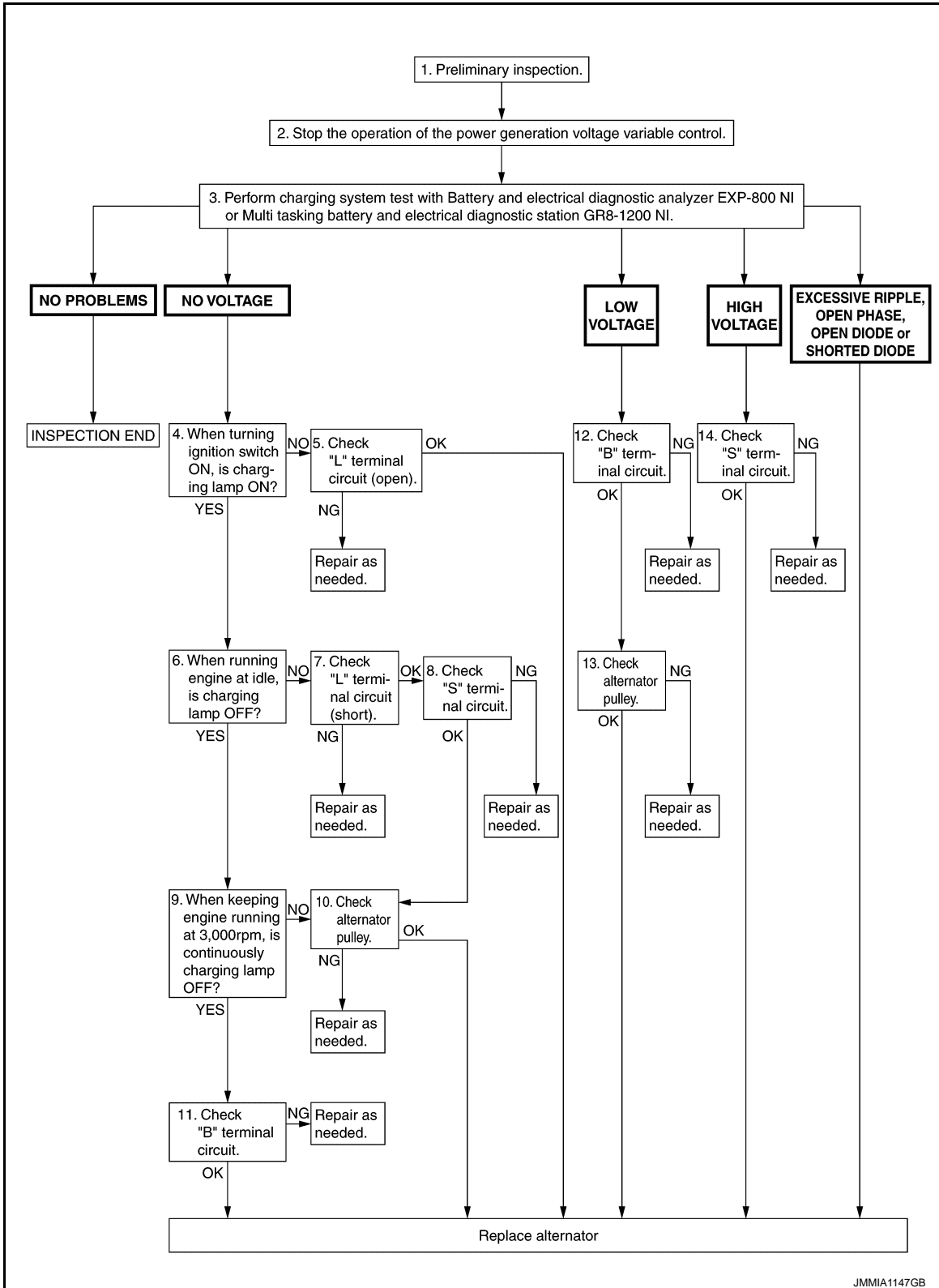

## DETAILED FLOW

### NOTE:

To ensure a complete and thorough diagnosis, the battery, starter and alternator test segments must be done as a set from start to finish.

### 1. PRELIMINARY INSPECTION

Perform the preliminary inspection. Refer to [CHG-21, "Inspection Procedure"](#).

# DIAGNOSIS AND REPAIR WORK FLOW

## < BASIC INSPECTION >

---

>> GO TO 2.

### 2. STOP POWER GENERATION VOLTAGE VARIABLE CONTROL SYSTEM

---

Stop the operation of the power generation voltage variable control in either of the following procedures.

- After selecting “ENGINE” of “SELECT SYSTEM” using CONSULT, set the DUTY value of “ALTERNATOR DUTY” to 0 % by selecting “ALTERNATOR DUTY” of “Active Test”. Continue “Active Test” until the end of inspection. (When the DUTY value is 0 or 100 %, the normal power generation is performed according to the characteristic of the IC voltage regulator of the alternator.)
- Turn the ignition switch OFF, and disconnect the battery current sensor connector. [However, DTC (P1550 - P1554) of the engine might remain. After finishing the inspection, connect the battery current sensor connector and erase the self-diagnosis results history of the engine using CONSULT.]

>> GO TO 3.

### 3. DIAGNOSIS WITH EXP-800 NI OR GR8-1200 NI

---

Perform the charging system test using Multitasking battery and electrical diagnostic station GR8-1200 NI or Battery and electrical diagnostic analyzer EXP-800 NI. Refer to the applicable Instruction Manual for proper testing procedures.

#### Test result

NO PROBLEMS>>Charging system is normal and will also show “DIODE RIPPLE” test result.

NO VOLTAGE>>GO TO 4.

LOW VOLTAGE>>GO TO 12.

HIGH VOLTAGE>>GO TO 14.

EXCESSIVE RIPPLE, OPEN PHASE, OPEN DIODE or SHORTED DIODE>>Replace the alternator. Perform “DIODE RIPPLE” test again using Multitasking battery and electrical diagnostic station GR8-1200 NI or Battery and electrical diagnostic analyzer EXP-800 NI to confirm repair.

### 4. INSPECTION WITH CHARGE WARNING LAMP (IGNITION SWITCH IS ON)

---

Turn the ignition switch ON.

Does the charge warning lamp illuminate?

YES >> GO TO 6.

NO >> GO TO 5.

### 5. “L” TERMINAL CIRCUIT (OPEN) INSPECTION

---

Check “L” terminal circuit (open). Refer to [CHG-25, "Diagnosis Procedure"](#).

Is the “L” terminal circuit normal?

YES >> Replace alternator. Refer to [CHG-31, "Removal and Installation"](#).

NO >> Repair as needed.

### 6. INSPECTION WITH CHARGE WARNING LAMP (IDLING)

---

Start the engine and run it at idle.

Does the charge warning lamp turn OFF?

YES >> GO TO 9.

NO >> GO TO 7.

### 7. “L” TERMINAL CIRCUIT (SHORT) INSPECTION

---

Check “L” terminal circuit (short). Refer to [CHG-27, "Diagnosis Procedure"](#).

Is the “L” terminal circuit normal?

YES >> GO TO 8.

NO >> Repair as needed.

### 8. “S” TERMINAL CIRCUIT INSPECTION

---

Check “S” terminal circuit. Refer to [CHG-28, "Diagnosis Procedure"](#).

Is the “S” terminal circuit normal?

YES >> GO TO 10.

NO >> Repair as needed.



# DIAGNOSIS AND REPAIR WORK FLOW

< BASIC INSPECTION >

---

## 9.INSPECTION WITH CHARGE WARNING LAMP (ENGINE AT 3,000 RPM)

---

Increase and maintain the engine speed at 3,000 rpm.

Does the charge warning lamp remain off?

YES >> GO TO 11.

NO >> GO TO 10.

---

## 10.INSPECTION OF ALTERNATOR PULLEY

---

Check alternator pulley. Refer to [CHG-32, "Inspection"](#).

Is alternator pulley normal?

YES >> Replace alternator. Refer to [CHG-31, "Removal and Installation"](#).

NO >> Repair as needed.

---

## 11."B" TERMINAL CIRCUIT INSPECTION

---

Check "B" terminal circuit. Refer to [CHG-24, "Diagnosis Procedure"](#).

Is "B" terminal circuit normal?

YES >> Replace alternator. Refer to [CHG-31, "Removal and Installation"](#).

NO >> Repair as needed.

---

## 12."B" TERMINAL CIRCUIT INSPECTION

---

Check "B" terminal circuit. Refer to [CHG-24, "Diagnosis Procedure"](#).

Is "B" terminal circuit normal?

YES >> GO TO 13.

NO >> Repair as needed.

---

## 13.INSPECTION OF ALTERNATOR PULLEY

---

Check alternator pulley. Refer to [CHG-32, "Inspection"](#).

Is alternator pulley normal?

YES >> Replace alternator. Refer to [CHG-31, "Removal and Installation"](#).

NO >> Repair as needed.

---

## 14."S" TERMINAL CIRCUIT INSPECTION

---

Check "S" terminal circuit. Refer to [CHG-28, "Diagnosis Procedure"](#).

Is the "S" terminal circuit normal?

YES >> Replace alternator. Refer to [CHG-31, "Removal and Installation"](#).

NO >> Repair as needed.

A  
B  
C  
D  
E  
F  
G  
H  
I  
J  
K  
L  
N  
O  
P

CHG

# DIAGNOSIS AND REPAIR WORK FLOW

< BASIC INSPECTION >

Work Flow (Without EXP-800 NI or GR8-1200 NI)

INFOID:00000009650423

## OVERALL SEQUENCE

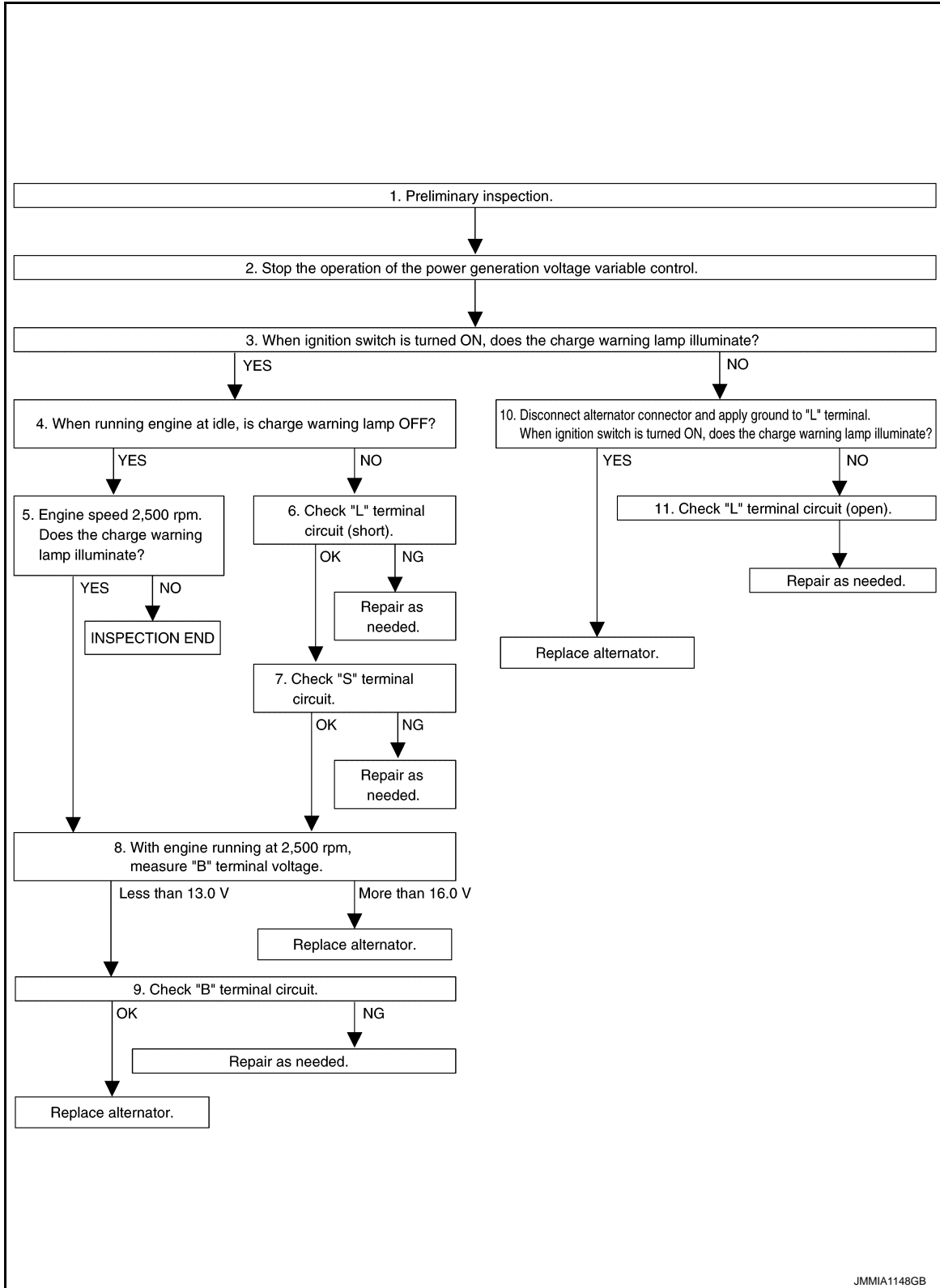

## DETAILED FLOW

### 1. PRELIMINARY INSPECTION

Perform the preliminary inspection. Refer to [CHG-21, "Inspection Procedure"](#).

# DIAGNOSIS AND REPAIR WORK FLOW

## < BASIC INSPECTION >

---

>> GO TO 2.

### 2. STOP POWER GENERATION VOLTAGE VARIABLE CONTROL SYSTEM

---

Stop the operation of the power generation voltage variable control in either of the following procedures.

- After selecting “ENGINE” of “SELECT SYSTEM” using CONSULT, set the DUTY value of “ALTERNATOR DUTY” to 0 % by selecting “ALTERNATOR DUTY” of “Active Test”. Continue “Active Test” until the end of inspection. (When the DUTY value is 0 or 100 %, the normal power generation is performed according to the characteristic of the IC regulator of the alternator.)
- Turn the ignition switch OFF, and disconnect the battery current sensor connector. [However, DTC (P1550 - P1554) of the engine might remain. After finishing the inspection, connect the battery current sensor connector and erase the self-diagnostic results history of the engine using CONSULT.]

>> GO TO 3.

### 3. INSPECTION WITH CHARGE WARNING LAMP (IGNITION SWITCH IS TURNED ON)

---

When ignition switch is turned ON

Does the charge warning lamp illuminate?

YES >> GO TO 4.

NO >> GO TO 10.

### 4. INSPECTION WITH CHARGE WARNING LAMP (IDLING)

---

Start the engine and run it at idle.

Does the charge warning lamp turn OFF?

YES >> GO TO 5.

NO >> GO TO 6.

### 5. INSPECTION WITH CHARGE WARNING LAMP (ENGINE AT 2,500 RPM)

---

Increase and maintain the engine speed at 2,500 rpm.

Does the charge warning lamp illuminate?

YES >> GO TO 8.

NO >> INSPECTION END

### 6. “L” TERMINAL CIRCUIT (SHORT) INSPECTION

---

Check “L” terminal circuit (short). Refer to [CHG-27. "Diagnosis Procedure"](#).

Is the inspection result normal?

YES >> GO TO 7.

NO >> Repair as needed.

### 7. “S” TERMINAL CIRCUIT INSPECTION

---

Check “S” terminal circuit. Refer to [CHG-28. "Diagnosis Procedure"](#).

Is the inspection result normal?

YES >> GO TO 8.

NO >> Repair as needed.

### 8. MEASURE “B” TERMINAL VOLTAGE

---

Start engine. With engine running at 2,500 rpm, measure “B” terminal voltage.

What voltage does the measurement result show?

Less than 13.0 V >> GO TO 9.

More than 16.0 V >> Replace alternator. Refer to [CHG-31. "Removal and Installation"](#).

### 9. “B” TERMINAL CIRCUIT INSPECTION

---

Check “B” terminal circuit. Refer to [CHG-24. "Diagnosis Procedure"](#).

Is the inspection result normal?

YES >> Replace alternator. Refer to [CHG-31. "Removal and Installation"](#).

NO >> Repair as needed.

### 10. INSPECTION WITH CHARGE WARNING LAMP (IGNITION SWITCH IS ON)

---

A

B

C

D

E

F

G

H

I

J

K

L

CHG

N

O

P

## DIAGNOSIS AND REPAIR WORK FLOW

### < BASIC INSPECTION >

---

1. Disconnect alternator connector and apply ground to "L" terminal.
2. Turn the ignition switch ON.

Does the charge warning lamp illuminate?

- YES >> Replace alternator. Refer to [CHG-31. "Removal and Installation"](#).  
NO >> GO TO 11.

### 11.CHECK "L" TERMINAL CIRCUIT (OPEN)

---

Check "L" terminal circuit (open). Refer to [CHG-25. "Diagnosis Procedure"](#).

>> Repair as needed.

# CHARGING SYSTEM PRELIMINARY INSPECTION

< BASIC INSPECTION >

## CHARGING SYSTEM PRELIMINARY INSPECTION

### Inspection Procedure

INFOID:000000009650424

#### 1. CHECK BATTERY TERMINALS CONNECTION

Check if battery terminals are clean and tight.

Is the inspection result normal?

YES >> GO TO 2.

NO >> Repair battery terminals connection.

#### 2. CHECK FUSE

Check for blown fuse and fusible link.

Unit	Power source (Power supply terminals)	Fuse No.
Alternator	Battery ("S" terminal)	38
Combination meter	Ignition switch ON ("L" terminal)	4

Is the inspection result normal?

YES >> GO TO 3.

NO >> Be sure to eliminate the cause of malfunction before installing new fuse.

#### 3. CHECK "E" TERMINAL CONNECTION (ALTERNATOR GROUND)

Check if "E" terminal (alternator ground) is clean and tight.

Is the inspection result normal?

YES >> GO TO 4.

NO >> Repair "E" terminal (alternator ground) connection.

#### 4. CHECK DRIVE BELT TENSION

Check drive belt tension. Refer to [EM-14, "Checking"](#).

Is the inspection result normal?

YES >> INSPECTION END

NO >> Repair as needed.

A  
B  
C  
D  
E  
F  
G  
H  
I  
J  
K  
L  
N  
O  
P

CHG

# POWER GENERATION VOLTAGE VARIABLE CONTROL SYSTEM OPERATION INSPECTION

< BASIC INSPECTION >

## POWER GENERATION VOLTAGE VARIABLE CONTROL SYSTEM OPERATION INSPECTION

Inspection Procedure

INFOID:000000009650425

### CAUTION:

When performing this inspection, always use a charged battery that has completed the battery inspection. (When the charging rate of the battery is low, the response speed of the voltage change will become slow. This can cause an incorrect inspection.)

### 1. CHECK ECM (CONSULT)

Perform ECM self-diagnosis with CONSULT. Refer to [EC-69, "CONSULT Function"](#).

#### Self-diagnostic results content

No malfunction detected>> GO TO 2.

Malfunction detected>> Check applicable parts, and repair or replace corresponding parts.

### 2. CHECK OPERATION OF POWER GENERATION VOLTAGE VARIABLE CONTROL SYSTEM

1. Connect CONSULT and start the engine.
2. Check that the selector lever is in "P" or "N" position and that all of the electric loads and A/C, etc. are turned OFF.
3. Select "ALTERNATOR DUTY" at "Active Test" of "ENGINE", and then check the value of "BATTERY VOLT" monitor when DUTY value of "ALTERNATOR DUTY" is set to 40.0 %.

#### "BATTERY VOLT"

**2 seconds after setting the DUTY value of "ALTERNATOR DUTY" to 40.0 % : 12 - 13.6 V**

4. Check the value of "BATTERY VOLT" monitor when DUTY value of "ALTERNATOR DUTY" is set to 80.0%.

#### "BATTERY VOLT"

**20 seconds after setting the DUTY value of "ALTERNATOR DUTY" to 80.0 % : +0.5 V or more against the value of "BATTERY VOLT" monitor when DUTY value is 40.0 %**

Is the measurement value within the specification?

YES >> INSPECTION END

NO >> GO TO 3.

### 3. CHECK IPDM E/R (CONSULT)

Perform IPDM E/R self-diagnosis with CONSULT. Refer to [PCS-13, "CONSULT Function \(IPDM E/R\)"](#).

#### Self-diagnostic results content

No malfunction detected>> GO TO 4.

Malfunction detected>> Check applicable parts, and repair or replace corresponding parts.

### 4. CHECK HARNESS BETWEEN ALTERNATOR AND IPDM E/R

1. Turn ignition switch OFF.
2. Disconnect alternator connector and IPDM E/R connector.
3. Check continuity between alternator harness connector and IPDM E/R harness connector.

Alternator harness connector		IPDM E/R harness connector		Continuity
Connector	Terminal	Connector	Terminal	
F60	5	F12	76	Existed

4. Check continuity between alternator harness connector and ground.

# POWER GENERATION VOLTAGE VARIABLE CONTROL SYSTEM OPERATION INSPECTION

< BASIC INSPECTION >

Alternator harness connector		Ground	Continuity
Connector	Terminal		
F60	5		Not existed

Is the inspection result normal?

YES >> Replace IPDM E/R.

NO >> Repair harness or connector between IPDM E/R and alternator.

A  
B  
C  
D  
E  
F  
G  
H  
I  
J  
K  
L

**CHG**

N  
O  
P

# B TERMINAL CIRCUIT

< DTC/CIRCUIT DIAGNOSIS >

## DTC/CIRCUIT DIAGNOSIS

### B TERMINAL CIRCUIT

#### Description

INFOID:000000009650426

"B" terminal circuit supplies power to charge the battery and to operate the vehicle's electrical system.

#### Diagnosis Procedure

INFOID:000000009650427

#### 1. CHECK "B" TERMINAL CONNECTION

1. Turn ignition switch OFF.
2. Check if "B" terminal is clean and tight.

Is the inspection result normal?

YES >> GO TO 2.

NO >> Repair "B" terminal connection. Confirm repair by performing complete Charging system test using EXP-800 NI or GR8-1200 NI (if available). Refer to the applicable Instruction Manual for proper testing procedures.

#### 2. CHECK "B" TERMINAL CIRCUIT

Check voltage between alternator "B" terminal and ground.

Terminals			Voltage (Approx.)
(+)	(-)		
Alternator "B" terminal	Terminal		Battery voltage
F59	1	Ground	

Is the inspection result normal?

YES >> GO TO 3.

NO >> Check harness for open between alternator and fusible link.

#### 3. CHECK "B" TERMINAL CONNECTION (VOLTAGE DROP TEST)

1. Start engine, then engine running at idle and warm.
2. Check voltage between battery positive terminal and alternator "B" terminal.

Terminals			Voltage (Approx.)
(+)	(-)		
Battery positive terminal	Alternator "B" terminal	Terminal	Less than 0.2 V
	F59	1	

Is the inspection result normal?

YES >> "B" terminal circuit is normal. Refer to [CHG-14, "Work Flow \(With EXP-800 NI or GR8-1200 NI\)"](#) or [CHG-18, "Work Flow \(Without EXP-800 NI or GR8-1200 NI\)"](#).

NO >> Check harness between battery and alternator for poor continuity.



# L TERMINAL CIRCUIT (OPEN)

< DTC/CIRCUIT DIAGNOSIS >

## L TERMINAL CIRCUIT (OPEN)

### Description

INFOID:000000009650428

The "L" terminal circuit controls the charge warning lamp. The charge warning lamp illuminates when the ignition switch is set to ON or START. When the alternator is providing sufficient voltage with the engine running, the charge warning lamp will go off. If the charge warning lamp illuminates with the engine running, a malfunction is indicated.

### Diagnosis Procedure

INFOID:000000009650429

#### 1. CHECK "L" TERMINAL CONNECTION

1. Turn ignition switch OFF.
2. Check if "L" terminal is clean and tight.

Is the inspection result normal?

YES >> GO TO 2.

NO >> Repair "L" terminal connection. Confirm repair by performing complete Charging system test using EXP-800 NI or GR8-1200 NI (if available). Refer to the applicable Instruction Manual for proper testing procedures.

#### 2. CHECK "L" TERMINAL CIRCUIT (OPEN)

1. Disconnect alternator connector.
2. Apply ground to alternator harness connector terminal.
3. Check condition of the charge warning lamp with the ignition switch in the ON position.

Alternator harness connector	Terminal	Ground	Condition	
			Ignition switch position	Charge warning lamp
F60	3		ON	Illuminate

Does it illuminate?

YES >> "L" terminal circuit is normal. Refer to [CHG-14, "Work Flow \(With EXP-800 NI or GR8-1200 NI\)"](#) or [CHG-18, "Work Flow \(Without EXP-800 NI or GR8-1200 NI\)"](#).

NO >> GO TO 3.

#### 3. CHECK HARNESS CONTINUITY (OPEN CIRCUIT)

1. Disconnect the battery cable from the negative terminal.
2. Disconnect the combination meter connector.
3. Check continuity between alternator harness connector and combination meter harness connector.

Alternator harness connector		Combination meter harness connector		Continuity
Connector No.	Terminal No.	Connector No.	Terminal No.	
F60	3	M34	25	Existed

Is the inspection result normal?

YES >> GO TO 4.

NO >> Repair the harness or connector.

#### 4. CHECK HARNESS CONTINUITY (OPEN CIRCUIT)

Check continuity between combination meter harness connector M34 terminal 2 and 10A fuse [No.4 located in the fuse block (J/B)].

Does continuity exist?

YES >> GO TO 5.

NO >> Repair the harness.

#### 5. CHECK POWER SUPPLY CIRCUIT

1. Connect the battery cable to the negative terminal.
2. Check voltage between combination meter harness connector and ground.

## L TERMINAL CIRCUIT (OPEN)

< DTC/CIRCUIT DIAGNOSIS >

Terminals		(-)	Condition	Voltage (Approx.)
(+)	Terminal			
Combination meter harness connector				
M34	2	Ground	When the ignition switch is in ON position	Battery voltage

Is the inspection result normal?

YES >> Replace combination meter.

NO >> Inspect the power supply circuit. Refer to [PG-54, "Wiring Diagram - IGNITION POWER SUPPLY -](#)

[".](#)

# L TERMINAL CIRCUIT (SHORT)

< DTC/CIRCUIT DIAGNOSIS >

## L TERMINAL CIRCUIT (SHORT)

### Description

INFOID:000000009650430

The "L" terminal circuit controls the charge warning lamp. The charge warning lamp illuminates when the ignition switch is set to ON or START. When the alternator is providing sufficient voltage with the engine running, the charge warning lamp will go off. If the charge warning lamp illuminates with the engine running, a malfunction is indicated.

### Diagnosis Procedure

INFOID:000000009650431

#### 1. CHECK "L" TERMINAL CIRCUIT (SHORT)

1. Turn ignition switch OFF.
2. Disconnect alternator connector.
3. Turn ignition switch ON.

Does charge warning lamp illuminate?

YES >> GO TO 2.

NO >> Refer to [CHG-14. "Work Flow \(With EXP-800 NI or GR8-1200 NI\)"](#) or [CHG-18. "Work Flow \(Without EXP-800 NI or GR8-1200 NI\)"](#).

#### 2. CHECK HARNESS CONTINUITY (SHORT CIRCUIT)

1. Turn ignition switch OFF.
2. Disconnect the battery cable from the negative terminal.
3. Disconnect combination meter connector.
4. Check continuity between combination meter harness connector and ground.

Combination meter harness connector		Ground	Continuity
Connector No.	Terminal No.		
M34	25		Not existed

Is the inspection result normal?

YES >> Replace combination meter.

NO >> Repair the harness.

A  
B  
C  
D  
E  
F  
G  
H  
I  
J  
K  
L

CHG

# S TERMINAL CIRCUIT

< DTC/CIRCUIT DIAGNOSIS >

## S TERMINAL CIRCUIT

### Description

INFOID:000000009650432

The output voltage of the alternator is controlled by the IC voltage regulator at the "S" terminal detecting the input voltage.

The "S" terminal circuit detects the battery voltage to adjust the alternator output voltage with the IC voltage regulator.

### Diagnosis Procedure

INFOID:000000009650433

#### 1.CHECK "S" TERMINAL CONNECTION

1. Turn ignition switch OFF.
2. Check if "S" terminal is clean and tight.

Is the inspection result normal?

YES >> GO TO 2.

NO >> Repair "S" terminal connection. Confirm repair by performing complete Charging system test using EXP-800 NI or GR8-1200 NI (if available). Refer to the applicable Instruction Manual for proper testing procedures.

#### 2.CHECK "S" TERMINAL CIRCUIT

Check voltage between alternator harness connector and ground.

Terminals		Voltage (Approx.)
(+)	(-)	
Alternator harness connector	Terminal	Battery voltage
F60	4	
	Ground	

Is the inspection result normal?

YES >> Refer to [CHG-14, "Work Flow \(With EXP-800 NI or GR8-1200 NI\)"](#) or [CHG-18, "Work Flow \(With-out EXP-800 NI or GR8-1200 NI\)"](#).

NO >> Check harness for open between alternator and fuse.

# CHARGING SYSTEM

< SYMPTOM DIAGNOSIS >

## SYMPTOM DIAGNOSIS

### CHARGING SYSTEM

#### Symptom Table

INFOID:000000009650434

Symptom	Reference
Discharged battery	Refer to <a href="#">CHG-14, "Work Flow (With EXP-800 NI or GR8-1200 NI)"</a> or <a href="#">CHG-18, "Work Flow (Without EXP-800 NI or GR8-1200 NI)"</a> .
The charge warning lamp does not illuminate when the ignition switch is set to ON.	
The charge warning lamp does not turn OFF after the engine starts.	
The charging warning lamp turns ON when increasing the engine speed.	

A  
B  
C  
D  
E  
F  
G  
H  
I  
J  
K  
L  
N  
O  
P

CHG

# ALTERNATOR

< REMOVAL AND INSTALLATION >

## REMOVAL AND INSTALLATION

### ALTERNATOR

Exploded View

INFOID:000000009650435

#### REMOVAL

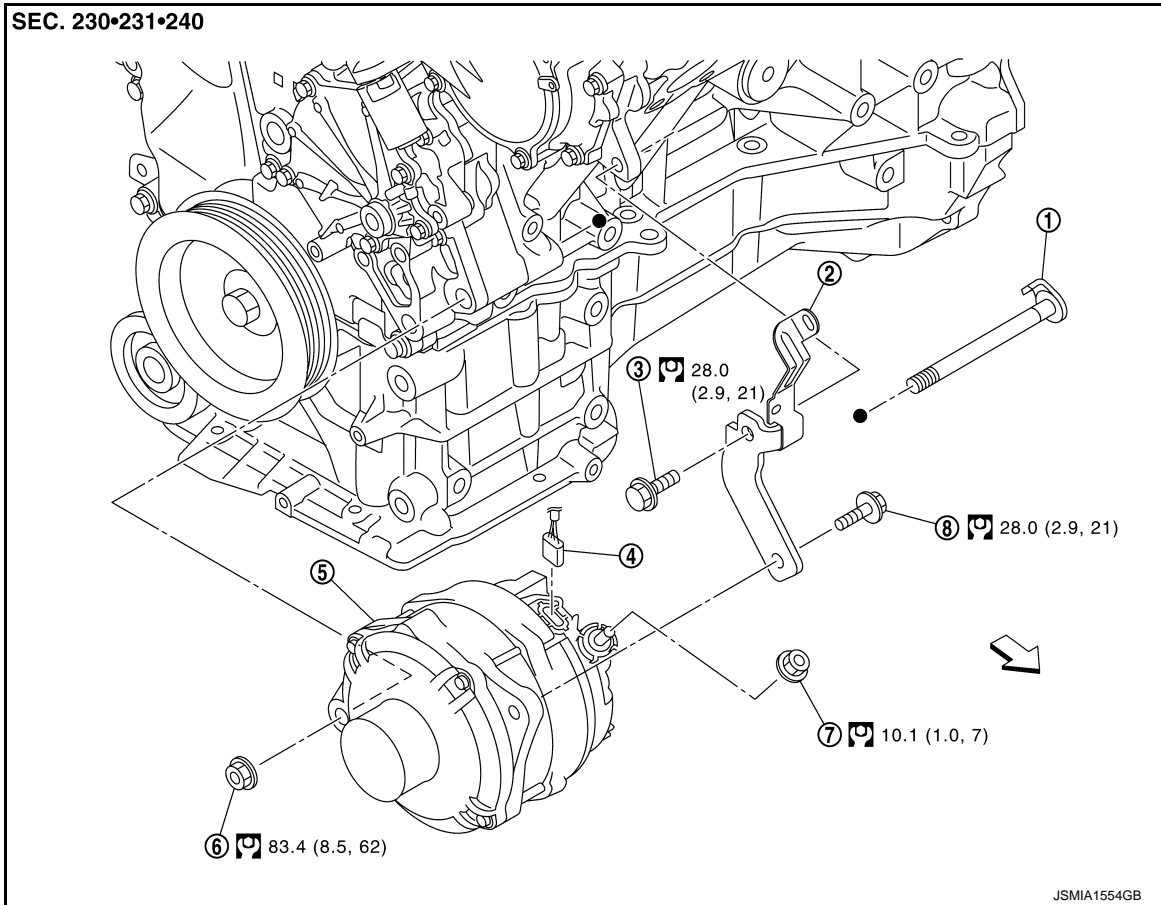

- |                                     |                                     |                                     |
|-------------------------------------|-------------------------------------|-------------------------------------|
| 1. Alternator mounting bolt (lower) | 2. Alternator bracket               | 3. Alternator bracket mounting bolt |
| 4. Alternator harness connector     | 5. Alternator                       | 6. Alternator mounting nut (lower)  |
| 7. "B" terminal harness nut         | 8. Alternator mounting bolt (upper) |                                     |

⬅ : Vehicle front

: N·m (kg-m, ft-lb)

#### DISASSEMBLY

# ALTERNATOR

## < REMOVAL AND INSTALLATION >

Type: A003TJ1791

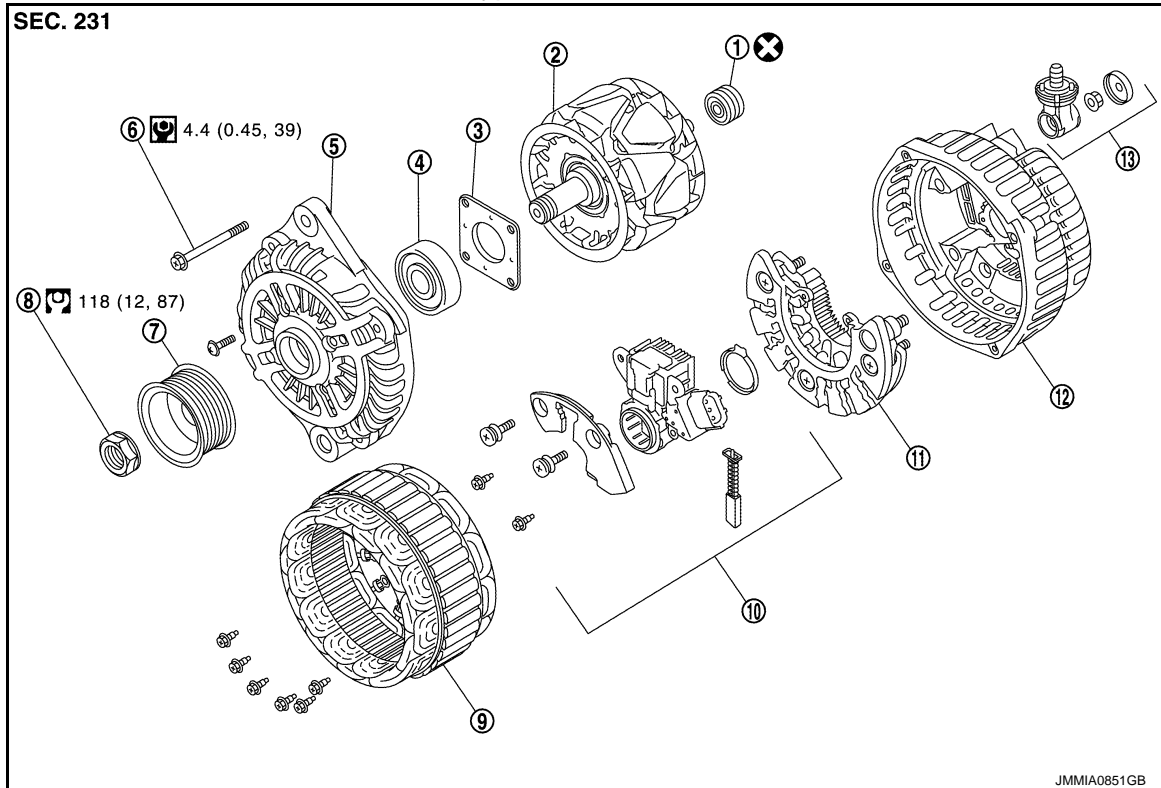

- |                                   |                           |                           |
|-----------------------------------|---------------------------|---------------------------|
| 1. Rear bearing                   | 2. Rotor assembly         | 3. Retainer               |
| 4. Front bearing                  | 5. Front bracket assembly | 6. Through bolt           |
| 7. Pulley                         | 8. Pulley nut             | 9. Stator assembly        |
| 10. IC voltage regulator assembly | 11. Diode assembly        | 12. Rear bracket assembly |
| 13. Terminal set                  |                           |                           |

⊗ : Always replace after every disassembly.

⊕ : N·m (kg·m, in·lb)

⊖ : N·m (kg·m, ft·lb)

## Removal and Installation

INFOID:000000009650436

### REMOVAL

1. Disconnect the battery cable from the negative terminal.  
**CAUTION:**  
**To prevent damage to the parts, disconnect the battery cable from the negative terminal first.**
2. Remove air duct (inlet). Refer to [EM-26. "Exploded View"](#).
3. Remove reservoir tank. Refer to [CO-13. "Exploded View"](#).
4. Disconnect alternator harness connector.
5. Remove "B" terminal harness nut, and then disconnect "B" terminal harness.
6. Remove alternator mounting bolt (upper).
7. Remove engine under cover. Refer to [EXT-28. "Exploded View"](#).
8. Remove front wheel RH.
9. Remove splash guard RH. Refer to [EXT-23. "Removal and Installation"](#).
10. Remove drive belt. Refer to [EM-13. "Removal and Installation"](#).
11. Remove idler pulley. Refer to [EM-13. "Removal and Installation"](#).
12. Remove compressor mounting bolts, and then move compressor to secure work space. Refer to [HA-30. "Exploded View"](#).

A  
B  
C  
D  
E  
F  
G  
H  
I  
J  
K  
L

CHG

N  
O  
P

# ALTERNATOR

## < REMOVAL AND INSTALLATION >

### CAUTION:

Never disconnect low-pressure flexible hose and high-pressure flexible hose from compressor.

13. Remove water pipe mounting bolts, and then move water pipe to secure work space. Refer to [LU-12](#), "[Exploded View](#)".

### CAUTION:

Never disconnect water hose from water pipe.

14. Remove return tube fixing clamps, and then move return tube to secure work space. Refer to [ST-35](#), "[Exploded View](#)".

### CAUTION:

Never disconnect return tube from return hose assembly.

15. Remove alternator mounting bolt (lower) and alternator mounting nut (lower).

16. Remove alternator from the right side of the vehicle.

### CAUTION:

Be careful not to contact with and damage surrounding parts when removing alternator from the vehicle.

⇐ : Vehicle front

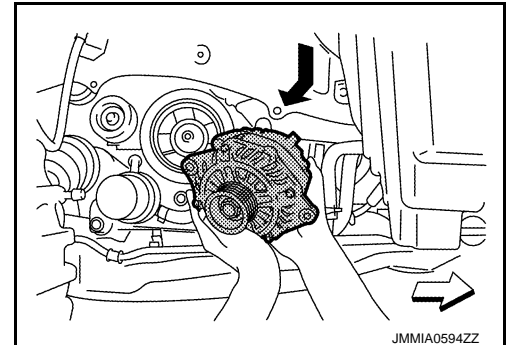

## INSTALLATION

Note the following items, and then install in the reverse order of removal.

### CAUTION:

- Temporarily tighten all of alternator bolts and nut. And then tighten them in numerical order shown in the figure.

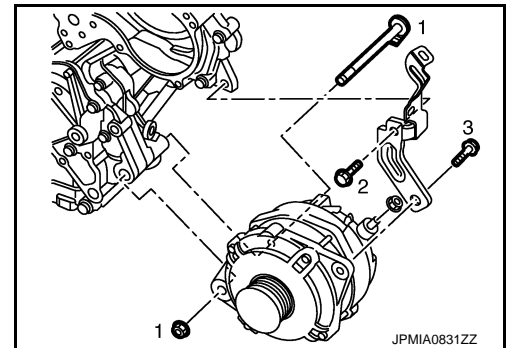

- Install alternator, and check tension of belt. Refer to [EM-14](#), "[Checking](#)".
- Be careful to tighten "B" terminal nut carefully.
- For this model, the power generation voltage variable control system that controls the power generation voltage of the alternator has been adopted. Therefore, the power generation voltage variable control system operation inspection should be performed after replacing the alternator, and then make sure that the system operates normally. Refer to [CHG-22](#), "[Inspection Procedure](#)".

## Inspection

INFOID:000000009650437

## ALTERNATOR PULLEY INSPECTION

Perform the following.

- Make sure that alternator pulley does not rattle.
- Make sure that alternator pulley nut is tight. Refer to [CHG-30](#), "[Exploded View](#)".



# SERVICE DATA AND SPECIFICATIONS (SDS)

< SERVICE DATA AND SPECIFICATIONS (SDS)

## SERVICE DATA AND SPECIFICATIONS (SDS)

### SERVICE DATA AND SPECIFICATIONS (SDS)

Alternator

INFOID:000000009650438

Type		A003TJ1791
		MITSUBISHI make
Nominal rating	[V - A]	12 -130
Ground polarity		Negative
Minimum revolution under no-load (When 13.5 V is applied)	[rpm]	Less than 1,300
Hot output current (When 13.5 V is applied)	[A/rpm]	More than 108/2,500 More than 124/5,000
Regulated output voltage	[V]	14.1 - 14.7*

\*: Adjustment range of power generation voltage variable control is 11.4 – 15.6 V.

A  
B  
C  
D  
E  
F  
G  
H  
I  
J  
K  
L  
N  
O  
P

**CHG**