

SECTION **EXT**  
EXTERIOR

A  
B  
C  
D  
E  
F  
G  
H  
I  
J  
L  
M  
N  
O  
P

CONTENTS

<b>PRECAUTION</b> .....	3	<b>FRONT SPOILER</b> .....	20
<b>PRECAUTIONS</b> .....	3	Exploded View .....	20
Precaution for Supplemental Restraint System (SRS) "AIR BAG" and "SEAT BELT PRE-TEN- SIONER" .....	3	Removal and Installation .....	20
Precaution for Procedure without Cowl Top Cover.....	3	<b>COWL TOP</b> .....	21
Precautions for Removing Battery Terminal .....	4	Exploded View .....	21
Precautions For Xenon Headlamp Service .....	4	Removal and Installation .....	22
<b>PREPARATION</b> .....	5	<b>FENDER PROTECTOR</b> .....	23
<b>PREPARATION</b> .....	5	Exploded View .....	23
Special Service Tools .....	5	Removal and Installation .....	23
Commercial Service Tools .....	5	<b>SIDE PROTECT MOLDING</b> .....	24
<b>SYMPTOM DIAGNOSIS</b> .....	6	Exploded View .....	24
<b>SQUEAK AND RATTLE TROUBLE DIAG- NOSES</b> .....	6	<b>FENDER PROTECT MOLDING</b> .....	24
Work Flow .....	6	FENDER PROTECT MOLDING : Removal and In- stallation .....	24
Inspection Procedure .....	8	<b>FRONT DOOR PROTECT MOLDING</b> .....	25
Diagnostic Worksheet .....	10	FRONT DOOR PROTECT MOLDING : Removal and Installation .....	25
<b>REMOVAL AND INSTALLATION</b> .....	12	<b>SLIDE DOOR PROTECT MOLDING</b> .....	26
<b>FRONT BUMPER</b> .....	12	SLIDE DOOR PROTECT MOLDING : Removal and Installation .....	26
Exploded View .....	12	<b>FLOOR SIDE FAIRING</b> .....	28
Removal and Installation .....	12	Exploded View .....	28
<b>REAR BUMPER</b> .....	15	Removal and Installation .....	28
Exploded View .....	15	<b>ROOF SIDE MOLDING</b> .....	29
<b>REAR BUMPER</b> .....	16	Exploded View .....	29
REAR BUMPER : Removal and Installation .....	16	Removal and Installation .....	29
<b>REAR BUMPER CLOSING</b> .....	17	<b>ROOF RAIL</b> .....	32
REAR BUMPER CLOSING : Removal and Instal- lation .....	17	Exploded View .....	32
<b>FRONT GRILLE</b> .....	18	Removal and Installation .....	32
Exploded View .....	18	<b>DOOR OUTSIDE MOLDING</b> .....	33
Removal and Installation .....	18	Exploded View .....	33
		Removal and Installation .....	33

EXT

<b>DOOR SASH MOLDING</b> .....	<b>36</b>	Removal and Installation .....	42
Exploded View .....	36		
Removal and Installation .....	36		
<b>BACK DOOR MOLDING</b> .....	<b>39</b>		
Exploded View .....	39		
Removal and Installation .....	39		
<b>DOOR PARTING SEAL</b> .....	<b>41</b>		
Exploded View .....	41		
Removal and Installation .....	41		
<b>SLIDE DOOR PARTING SEAL</b> .....	<b>42</b>		
Exploded View .....	42		
		<b>SLIDE DOOR RAIL COVER</b> .....	<b>43</b>
		Exploded View .....	43
		Removal and Installation .....	43
		<b>REAR SPOILER</b> .....	<b>45</b>
		Exploded View .....	45
		Removal and Installation .....	45
		<b>BACK DOOR FINISHER</b> .....	<b>47</b>
		Exploded View .....	47
		Removal and Installation .....	47

# PRECAUTIONS

< PRECAUTION >

## PRECAUTION

### PRECAUTIONS

#### Precaution for Supplemental Restraint System (SRS) "AIR BAG" and "SEAT BELT PRE-TENSIONER"

INFOID:000000009650479

The Supplemental Restraint System such as "AIR BAG" and "SEAT BELT PRE-TENSIONER", used along with a front seat belt, helps to reduce the risk or severity of injury to the driver and front passenger for certain types of collision. This system includes seat belt switch inputs and dual stage front air bag modules. The SRS system uses the seat belt switches to determine the front air bag deployment, and may only deploy one front air bag, depending on the severity of a collision and whether the front occupants are belted or unbelted. Information necessary to service the system safely is included in the "SRS AIR BAG" and "SEAT BELT" of this Service Manual.

#### **WARNING:**

Always observe the following items for preventing accidental activation.

- To avoid rendering the SRS inoperative, which could increase the risk of personal injury or death in the event of a collision that would result in air bag inflation, all maintenance must be performed by an authorized NISSAN/INFINITI dealer.
- Improper maintenance, including incorrect removal and installation of the SRS, can lead to personal injury caused by unintentional activation of the system. For removal of Spiral Cable and Air Bag Module, see "SRS AIR BAG".
- Never use electrical test equipment on any circuit related to the SRS unless instructed to in this Service Manual. SRS wiring harnesses can be identified by yellow and/or orange harnesses or harness connectors.

#### PRECAUTIONS WHEN USING POWER TOOLS (AIR OR ELECTRIC) AND HAMMERS

#### **WARNING:**

Always observe the following items for preventing accidental activation.

- When working near the Air Bag Diagnosis Sensor Unit or other Air Bag System sensors with the ignition ON or engine running, never use air or electric power tools or strike near the sensor(s) with a hammer. Heavy vibration could activate the sensor(s) and deploy the air bag(s), possibly causing serious injury.
- When using air or electric power tools or hammers, always switch the ignition OFF, disconnect the battery, and wait at least 3 minutes before performing any service.

#### Precaution for Procedure without Cowl Top Cover

INFOID:000000009650480

When performing the procedure after removing cowl top cover, cover the lower end of windshield with urethane, etc to prevent damage to windshield.

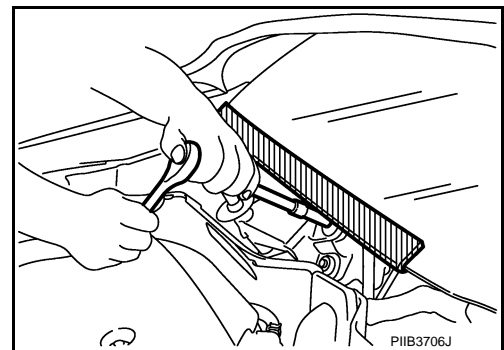

# PRECAUTIONS

## < PRECAUTION >

### Precautions for Removing Battery Terminal

INFOID:000000009888641

- When removing the 12V battery terminal, turn OFF the ignition switch and wait at least 30 seconds.

**NOTE:**

ECU may be active for several tens of seconds after the ignition switch is turned OFF. If the battery terminal is removed before ECU stops, then a DTC detection error or ECU data corruption may occur.

- For vehicles with the 2-batteries, be sure to connect the main battery and the sub battery before turning ON the ignition switch.

**NOTE:**

If the ignition switch is turned ON with any one of the terminals of main battery and sub battery disconnected, then DTC may be detected.

- After installing the 12V battery, always check "Self Diagnosis Result" of all ECUs and erase DTC.

**NOTE:**

The removal of 12V battery may cause a DTC detection error.

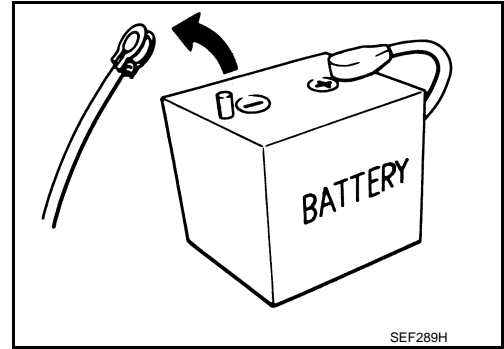

### Precautions For Xenon Headlamp Service

INFOID:000000009889378

**WARNING:**

Comply with the following warnings to prevent any serious accident.

- Disconnect the battery cable (negative terminal) or the power supply fuse before installing, removing, or touching the xenon headlamp (bulb included). The xenon headlamp contains high-voltage generated parts.
- Never work with wet hands.
- Check the xenon headlamp ON-OFF status after assembling it to the vehicle. Never turn the xenon headlamp ON in other conditions. Connect the power supply to the vehicle-side connector. (Turning it ON outside the lamp case may cause fire or visual impairments.)
- Never touch the bulb glass immediately after turning it OFF. It is extremely hot.

**CAUTION:**

Comply with the following cautions to prevent any error and malfunction.

- Install the xenon bulb securely. (Insufficient bulb socket installation may melt the bulb, the connector, the housing, etc. by high-voltage leakage or corona discharge.)
- Never perform HID circuit inspection with a tester.
- Never touch the xenon bulb glass with hands. Never put oil and grease on it.
- Dispose of the used xenon bulb after packing it in thick vinyl without breaking it.
- Never wipe out dirt and contamination with organic solvent (thinner, gasoline, etc.).

# PREPARATION

< PREPARATION >

## PREPARATION

### PREPARATION

#### Special Service Tools

INFOID:000000009650481

The actual shapes of Kent-Moore tools may differ from those of special service tools illustrated here.

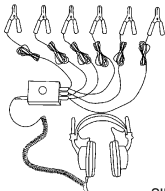
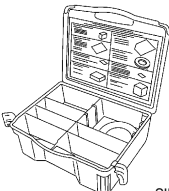
Tool number (Kent-Moore No.) Tool name	Description
<p>(J-39570) Chassis ear</p>  <p>SIIA0993E</p>	<p>Locates the noise</p>
<p>(J-50397) NISSAN Squeak and Rattle Kit</p>  <p>SIIA0994E</p>	<p>Repairs the cause of noise</p>

#### Commercial Service Tools

INFOID:000000009650482

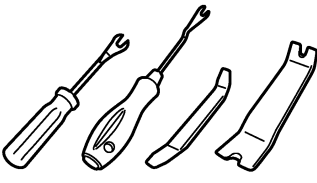
Tool name	Description
<p>Remover tool</p>  <p>JMKIA3050ZZ</p>	<p>Removes clips, pawls and metal clips</p>

A  
B  
C  
D  
E  
F  
G  
H  
I  
J  
L  
M  
N  
O  
P

EXT

# SQUEAK AND RATTLE TROUBLE DIAGNOSES

< SYMPTOM DIAGNOSIS >

## SYMPTOM DIAGNOSIS

### SQUEAK AND RATTLE TROUBLE DIAGNOSES

#### Work Flow

INFOID:000000009650483

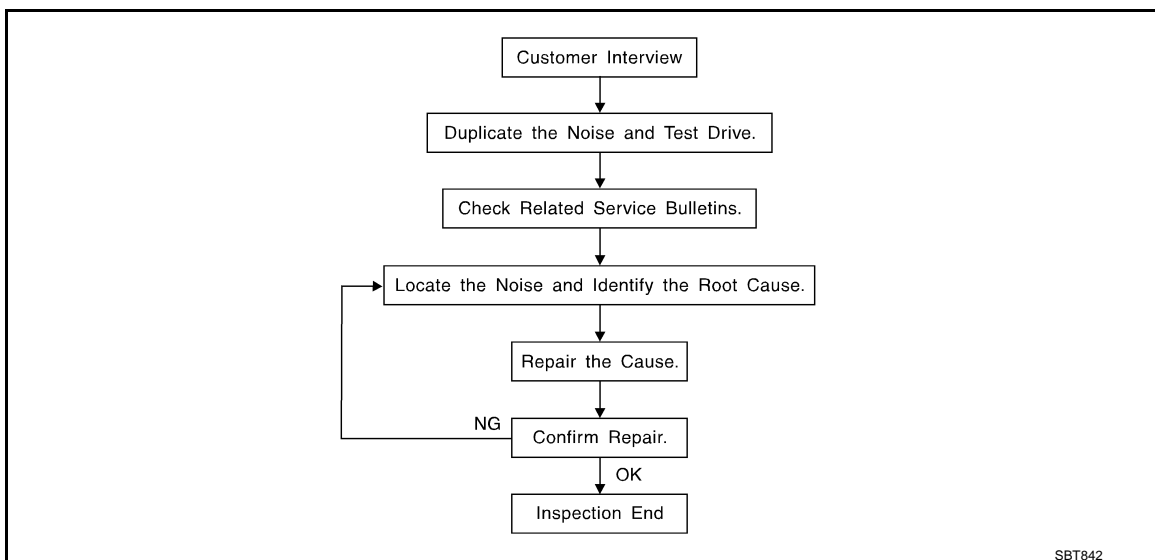

#### CUSTOMER INTERVIEW

Interview the customer if possible, to determine the conditions that exist when the noise occurs. Use the Diagnostic Worksheet during the interview to document the facts and conditions when the noise occurs and any customer comments. Refer to [EXT-10. "Diagnostic Worksheet"](#). This information is necessary to duplicate the conditions that exist when the noise occurs.

- The customer may not be able to provide a detailed description or the location of the noise. Attempt to obtain all the facts and conditions that exist when the noise occurs (or does not occur).
- If there is more than one noise in the vehicle, perform a diagnosis and repair the noise that the customer is concerned about. This can be accomplished by performing a test drive with the customer.
- After identifying the type of noise, isolate the noise in terms of its characteristics. The noise characteristics are provided so that the customer, service adviser, and technician use the same language when describing the noise.
- Squeak – (Like tennis shoes on a clean floor)  
Squeak characteristics include the light contact / fast movement / brought on by road conditions / hard surfaces = high-pitched noise / softer surfaces = low-pitched noises / edge to surface = chirping
- Creak – (Like walking on an old wooden floor)  
Creak characteristics include firm contact / slow movement/twisting with a rotational movement / pitch dependent on materials / often brought on by activity.
- Rattle – (Like shaking a baby rattle)  
Rattle characteristics include fast repeated contact / vibration or similar movement / loose parts/missing clip or fastener / incorrect clearance.
- Knock – (Like a knock on a door)  
Knock characteristics include hollow sounds / sometimes repeating / often brought on by driver action.
- Tick – (Like a clock second hand)  
Tick characteristics include gentle contacting of light materials / loose components / can be caused by driver action or road conditions.
- Thump – (Heavy, muffled knock noise)  
Thump characteristics include softer knock / dull sounds often brought on by activity.
- Buzz – (Like a bumblebee)  
Buzz characteristics include high frequency rattle / firm contact.
- Often the degree of acceptable noise level varies depending upon the person. A noise that a technician may judge as acceptable may be very irritating to a customer.
- Weather conditions, especially humidity and temperature, may have a great effect on noise level.

#### DUPLICATE THE NOISE AND TEST DRIVE

# SQUEAK AND RATTLE TROUBLE DIAGNOSES

## < SYMPTOM DIAGNOSIS >

If possible, drive the vehicle with the customer until the noise is duplicated. Note any additional information on the Diagnostic Worksheet regarding the conditions or location of the noise. This information can be used to duplicate the same conditions when the repair is reconfirmed.

If the noise can be duplicated easily during the test drive, to help identify the source of the noise, try to duplicate the noise with the vehicle stopped by doing one or all of the following items:

- 1) Close a door.
  - 2) Tap or push/pull around the area where the noise appears to be coming from.
  - 3) Rev the engine.
  - 4) Use a floor jack to recreate vehicle "twist".
  - 5) At idle, apply engine load (electrical load, half-clutch on M/T models, drive position on A/T models).
  - 6) Raise the vehicle on a hoist and hit a tire with a rubber hammer.
- Drive the vehicle and attempt to duplicate the conditions the customer states exist when the noise occurs.
  - If it is difficult to duplicate the noise, drive the vehicle slowly on an undulating or rough road to stress the vehicle body.

## CHECK RELATED SERVICE BULLETINS

After verifying the customer concern or symptom, check ASIST for Technical Service Bulletins (TSBs) related to the concern or symptom.

If a TSB relates to the symptom, follow the procedure to repair the noise.

## LOCATE THE NOISE AND IDENTIFY THE ROOT CAUSE

1. Narrow down the noise to a general area. To help pinpoint the source of the noise, use a listening tool (Chassis ear: J-39570, engine ear, and mechanics stethoscope).
2. Narrow down the noise to a more specific area and identify the cause of the noise by:
  - Removing the component(s) in the area that is / are suspected to be the cause of the noise. Do not use too much force when removing clips and fasteners, otherwise clips and fasteners can be broken or lost during the repair, resulting in the creation of new noise.
  - Tapping or pushing/pulling the component(s) that is / are suspected to be the cause of the noise. Do not tap or push/pull the component(s) with excessive force, otherwise the noise is eliminated only temporarily.
  - Feeling for a vibration by hand by touching the component(s) that is / are suspected to be the cause of the noise.
  - Placing a piece of paper between components that are suspected to be the cause of the noise.
  - Looking for loose components and contact marks.  
Refer to [EXT-8. "Inspection Procedure"](#).

## REPAIR THE CAUSE

- If the cause is a loose component, tighten the component securely.
- If the cause is insufficient clearance between components:
  - Separate components by repositioning or loosening and retightening the components, if possible.
  - Insulate components with a suitable insulator such as urethane pads, foam blocks, felt cloth tape, or urethane tape. A NISSAN Squeak and Rattle Kit (J-50397) is available through the authorized NISSAN Parts Department.

### **CAUTION:**

**Never use excessive force as many components are constructed of plastic and may be damaged.**

### **NOTE:**

Always check with the Parts Department for the latest parts information.

The following materials are contained in the NISSAN Squeak and Rattle Kit (J-50397) are listed on the inside cover of the kit; and can each be ordered separately as needed.

URETHANE PADS [1.5 mm (0.059 in) thick]

Insulates connectors, harness, etc.

- 76268-9E005: 100 × 135 mm (3.937 × 5.315 in)
- 76884-71L01: 60 × 85 mm (2.362 × 3.346 in)
- 76884-71L02: 15 × 25 mm (0.591 × 0.984 in)

INSULATOR (Foam blocks)

Insulates components from contact. Can be used to fill space behind a panel.

- 73982-9E000: 45 mm (1.772 in) thick, 50 × 50 mm (1.969 × 1.969 in)
- 73982-50Y00: 10 mm (0.394 in) thick, 50 × 50 mm (1.969 × 1.969 in)

INSULATOR (Light foam block)

80845-71L00: 30 mm (1.181 in) thick, 30 × 50 mm (1.181 × 1.969 in)

FELT CLOTHTAPE

# SQUEAK AND RATTLE TROUBLE DIAGNOSES

## < SYMPTOM DIAGNOSIS >

---

Used to insulate where movement does not occur. Ideal for instrument panel applications.

- 68370-4B000: 15 × 25 mm (0.591 × 0.984 in) pad
- 68239-13E00: 5 mm (0.197 in) wide tape roll

The following materials, not found in the kit, can also be used to repair squeaks and rattles.

### UHMW (TEFLON) TAPE

Insulates where slight movement is present. Ideal for instrument panel applications.

### SILICONE GREASE

Used in place of UHMW tape that is visible or does not fit. Only lasts a few months.

### SILICONE SPRAY

Used when grease cannot be applied.

### DUCT TAPE

Used to eliminate movement.

## CONFIRM THE REPAIR

After repair is complete, test drive the vehicle to confirm that the cause of noise is repaired by test driving the vehicle. Operate the vehicle under the same conditions as when the noise originally occurred. Refer to the notes on the Diagnostic Worksheet.

## Inspection Procedure

INFOID:000000009650484

Refer to Table of Contents for specific component removal and installation information.

## INSTRUMENT PANEL

Most incidents are caused by contact and movement between:

1. The cluster lid A and instrument panel
2. Acrylic lens and combination meter housing
3. Instrument panel to front pillar garnish
4. Instrument panel to windshield
5. Instrument panel mounting pins
6. Wiring harnesses behind the combination meter
7. A/C defroster duct and duct joint

These incidents can usually be located by tapping or moving the components to duplicate the noise or by pressing on the components while driving to stop the noise. Most of these incidents can be repaired by applying felt cloth tape or silicon spray (in hard to reach areas). Urethane pads can be used to insulate wiring harness.

### **CAUTION:**

**Never use silicone spray to isolate a squeak or rattle. If the area is saturated with silicone, the recheck of repair becomes impossible.**

## CENTER CONSOLE

Components to check include:

1. Shifter assembly cover to finisher
2. A/C control unit and cluster lid C
3. Wiring harnesses behind audio and A/C control unit

The instrument panel repair and isolation procedures also apply to the center console.

## DOORS

Check the following items:

1. Finisher and inner panel making a slapping noise
2. Inside handle escutcheon connection to door finisher
3. Wiring harnesses tapping
4. Door striker out of alignment causing a popping noise on starts and stops

Tapping, moving the components, or pressing on them while driving to duplicate the conditions can isolate many of these incidents. The areas can usually be insulated with felt cloth tape or insulator foam blocks from the NISSAN Squeak and Rattle Kit (J-50397) to repair the noise.

## TRUNK

Trunk noises are often caused by a loose jack or loose items put into the trunk by the customer.

In addition check for the following items:



# SQUEAK AND RATTLE TROUBLE DIAGNOSES

## < SYMPTOM DIAGNOSIS >

---

1. Trunk lid dumpers out of adjustment
2. Trunk lid striker out of adjustment
3. Trunk lid torsion bars knocking together
4. A loose license plate or bracket

Most of these incidents can be repaired by adjusting, securing, or insulating the item(s) or component(s) causing the noise.

## SUNROOF/HEADLINING

Noises in the sunroof / headlining area can often be traced to one of the following items:

1. Sunroof lid, rail, linkage, or seals making a rattle or light knocking noise
2. Sunvisor shaft shaking in the holder
3. Front or rear windshield touching headlining and squeaking

Again, pressing on the components to stop the noise while duplicating the conditions can isolate most of these incidents. Repairs usually consist of insulating with felt cloth tape.

## SEATS

When isolating seat noise it is important to note the position the seat is in and the load placed on the seat when the noise occurs. These conditions should be duplicated when verifying and isolating the cause of the noise.

Causes of seat noise include:

1. Headrest rods and holder
2. A squeak between the seat pad cushion and frame
3. The rear seatback lock and bracket

These noises can be isolated by moving or pressing on the suspected components while duplicating the conditions under which the noise occurs. Most of these incidents can be repaired by repositioning the component or applying urethane tape to the contact area.

## UNDERHOOD

Some interior noise may be caused by components under the hood or on the engine wall. The noise is then transmitted into the passenger compartment.

Causes of transmitted underhood noise include:

1. Any component mounted to the engine wall
2. Components that pass through the engine wall
3. Engine wall mounts and connectors
4. Loose radiator mounting pins
5. Hood bumpers out of adjustment
6. Hood striker out of adjustment

These noises can be difficult to isolate since they cannot be reached from the interior of the vehicle. The best method is to secure, move, or insulate one component at a time and test drive the vehicle. Also, engine RPM or load can be changed to isolate the noise. Repairs can usually be made by moving, adjusting, securing, or insulating the component causing the noise.

A  
B  
C  
D  
E  
F  
G  
H  
I  
J  
L  
M  
N  
O  
P

**EXT**

# SQUEAK AND RATTLE TROUBLE DIAGNOSES

< SYMPTOM DIAGNOSIS >

## Diagnostic Worksheet

INFOID:00000009650485



### SQUEAK & RATTLE DIAGNOSTIC WORKSHEET

Dear Nissan Customer:

We are concerned about your satisfaction with your Nissan vehicle. Repairing a squeak or rattle sometimes can be very difficult. To help us fix your Nissan right the first time, please take a moment to note the area of the vehicle where the squeak or rattle occurs and under what conditions. You may be asked to take a test drive with a service advisor or technician to ensure we confirm the noise you are hearing.

#### I. WHERE DOES THE NOISE COME FROM? (circle the area of the vehicle)

The illustrations are for reference only, and may not reflect the actual configuration of your vehicle.

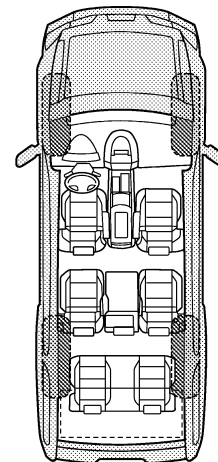
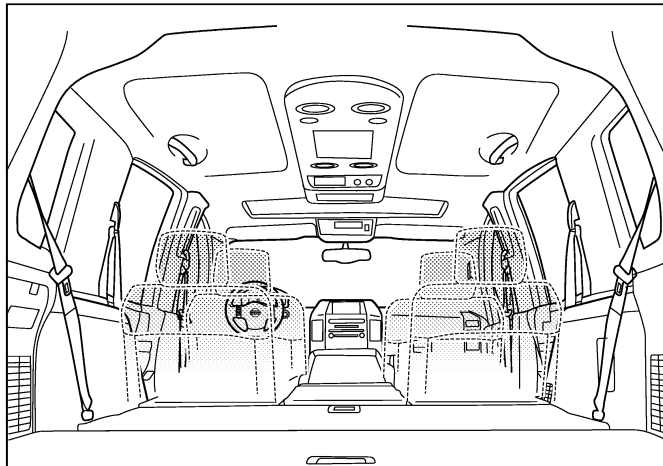
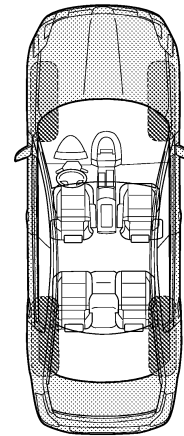
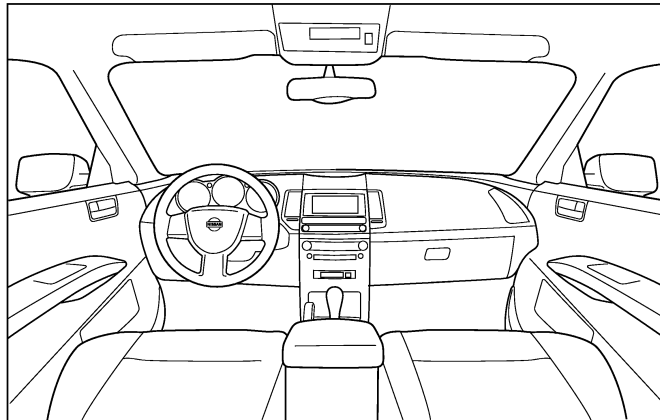

Continue to page 2 of the worksheet and briefly describe the location of the noise or rattle. In addition, please indicate the conditions which are present when the noise occurs.

PIIB8740E

# SQUEAK AND RATTLE TROUBLE DIAGNOSES

< SYMPTOM DIAGNOSIS >

## SQUEAK & RATTLE DIAGNOSTIC WORKSHEET - page 2

Briefly describe the location where the noise occurs:

---

---

### II. WHEN DOES IT OCCUR? (please check the boxes that apply)

- |   |  |
|---|--|
| <input type="checkbox"/> anytime                      | <input type="checkbox"/> after sitting out in the rain |
| <input type="checkbox"/> 1st time in the morning      | <input type="checkbox"/> when it is raining or wet     |
| <input type="checkbox"/> only when it is cold outside | <input type="checkbox"/> dry or dusty conditions       |
| <input type="checkbox"/> only when it is hot outside  | <input type="checkbox"/> other:                        |

### III. WHEN DRIVING:

- through driveways
- over rough roads
- over speed bumps
- only about \_\_\_\_ mph
- on acceleration
- coming to a stop
- on turns: left, right or either (circle)
- with passengers or cargo
- other: \_\_\_\_\_
- after driving \_\_\_\_ miles or \_\_\_\_ minutes

### IV. WHAT TYPE OF NOISE

- squeak (like tennis shoes on a clean floor)
- creak (like walking on an old wooden floor)
- rattle (like shaking a baby rattle)
- knock (like a knock at the door)
- tick (like a clock second hand)
- thump (heavy, muffled knock noise)
- buzz (like a bumble bee)

### TO BE COMPLETED BY DEALERSHIP PERSONNEL

#### Test Drive Notes:

---

---

---

	YES	NO	Initials of person performing
Vehicle test driven with customer	<input type="checkbox"/>	<input type="checkbox"/>	_____
- Noise verified on test drive	<input type="checkbox"/>	<input type="checkbox"/>	_____
- Noise source located and repaired	<input type="checkbox"/>	<input type="checkbox"/>	_____
- Follow up test drive performed to confirm repair	<input type="checkbox"/>	<input type="checkbox"/>	_____

VIN: \_\_\_\_\_ Customer Name: \_\_\_\_\_  
W.O.# \_\_\_\_\_ Date: \_\_\_\_\_

This form must be attached to Work Order

PIIB8742E

A  
B  
C  
D  
E  
F  
G  
H  
I  
J  
L  
M  
N  
O  
P

EXT

# FRONT BUMPER

< REMOVAL AND INSTALLATION >

## REMOVAL AND INSTALLATION

### FRONT BUMPER

Exploded View

INFOID:000000009650486

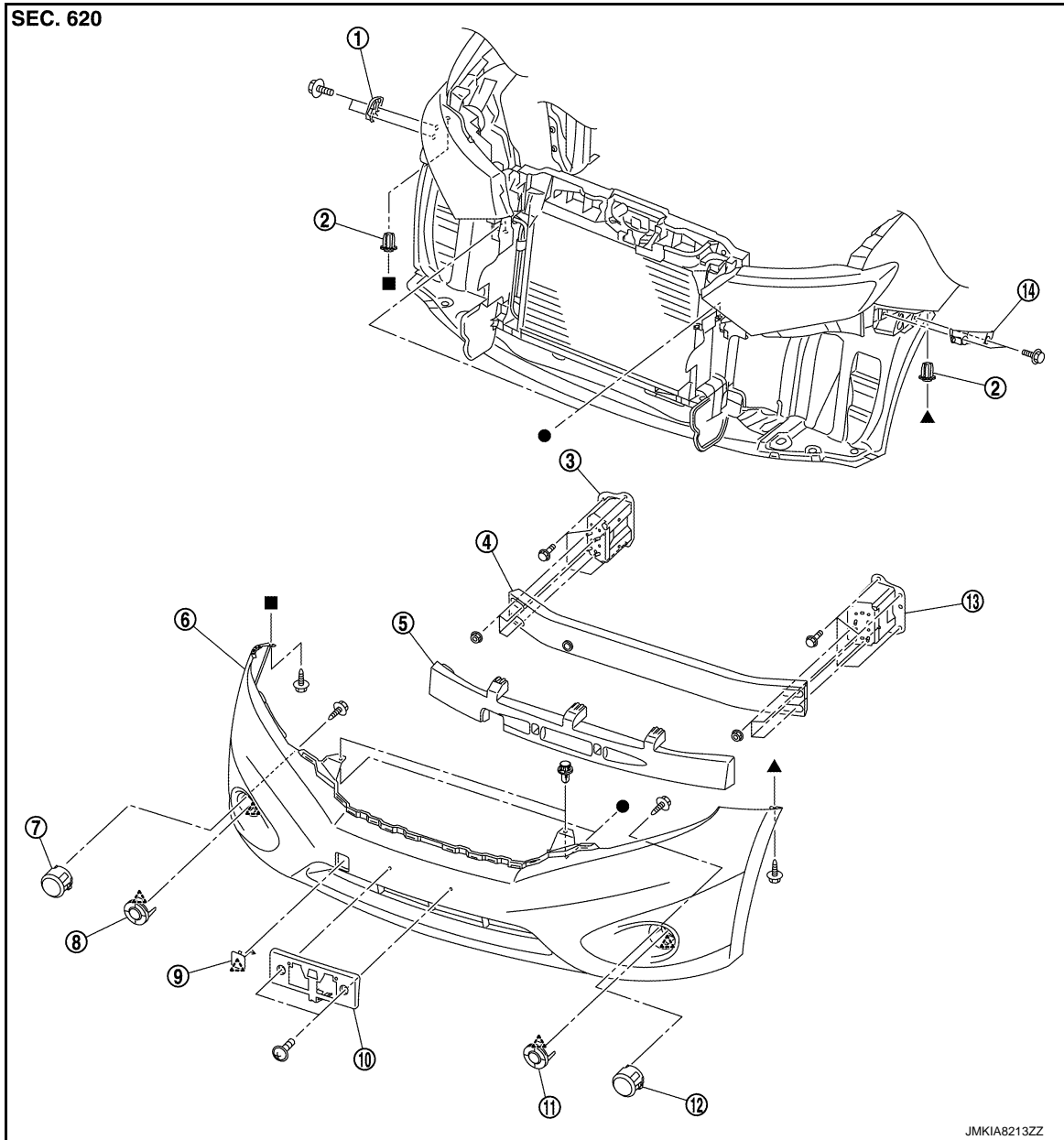

JMKIA8213ZZ

- |                           |                            |                         |
|---------------------------|----------------------------|-------------------------|
| 1. Bumper side bracket RH | 2. Screw grommet           | 3. Bumper stay RH       |
| 4. Bumper reinforcement   | 5. Bumper energy absorber  | 6. Bumper fascia        |
| 7. Front fog lamp RH      | 8. Bumper finisher RH      | 9. Bumper bracket cover |
| 10. License plate bracket | 11. Bumper finisher LH     | 12. Front fog lamp LH   |
| 13. Bumper stay LH        | 14. Bumper side bracket LH |                         |

△ : Pawl

●, ▲, ■ : Indicates that the part is connected at points with same symbol in actual vehicle.

### Removal and Installation

INFOID:000000009650487

**CAUTION:**

# FRONT BUMPER

## < REMOVAL AND INSTALLATION >

Bumper fascia is made of resin. Never apply strong force to it, and be careful to prevent contact with oil.

### REMOVAL

1. Fully open hood assembly.
2. Remove front grille. Refer to [EXT-18. "Removal and Installation"](#).
3. Remove fender protector (front) fixing clips and screws to access bumper fascia assembly fixing screw. Refer to [EXT-23. "Removal and Installation"](#).
4. Remove bumper fascia both ends fixing screws (A).

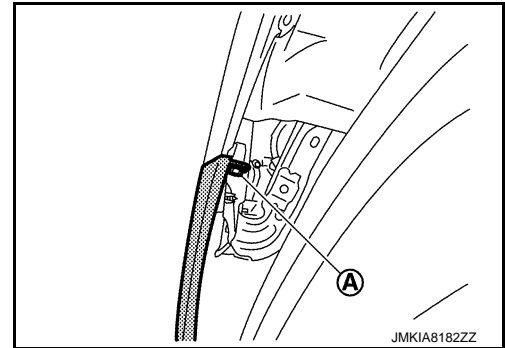

5. Remove bumper fascia assembly upper side fixing clips (A).  
**CAUTION:**  
Apply protective tape (B) around bumper fascia.

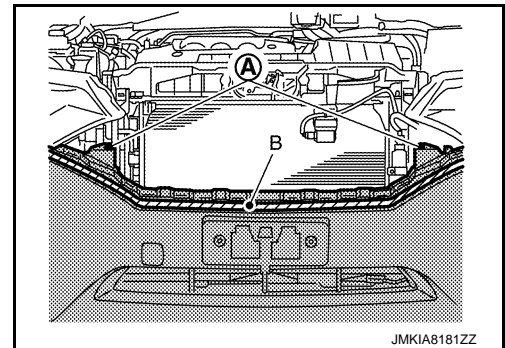

6. Remove bumper fascia assembly lower side fixing clips.
7. Pull bumper fascia assembly toward the vehicle out side as shown by the arrows in the figure, and then disengage bumper fascia assembly from bumper side brackets (LH and RH).  
**CAUTION:**  
When removing bumper fascia, 2 workers are required so as to prevent it from dropping.

 : Pawl

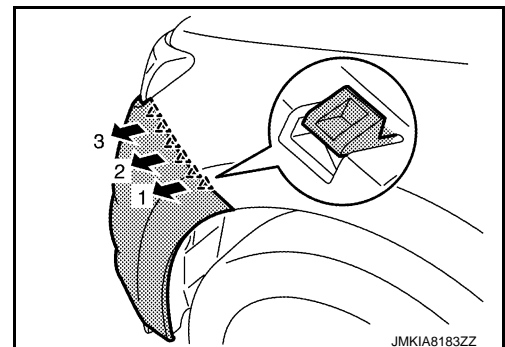

8. Disconnect front fog lamp harness connectors (LH and RH).
9. Remove bumper fascia assembly.  
**CAUTION:**  
When removing bumper fascia, 2 workers are required so as to prevent it from dropping.
10. Remove the following parts after removing bumper fascia.
  - Front fog lamp assembly (LH and RH). (with fog lamp)
  - Front fog lamp finishers (LH and RH). (without fog lamp)
  - Bumper bracket cover
  - Front spoiler
  - License plate bracket
11. Remove bumper energy absorber.
12. Remove bumper reinforcement mounting nuts, and then remove bumper reinforcement.
13. Remove bumper side bracket mounting screws, and then remove bumper side bracket.

# FRONT BUMPER

## < REMOVAL AND INSTALLATION >

### INSTALLATION

Note the following items, and then install in the reverse order of removal.

**NOTE:**

- The following table shows the specified values for checking normal installation status.
- Fitting adjustment cannot be performed.

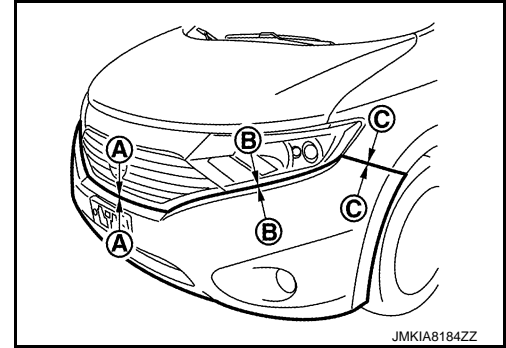

Portion		Clearance	Surface height difference
Bumper fascia assembly – Front grille	A – A	0.0 – 3.0 mm (0.000 – 0.118 in)	—
Bumper fascia assembly – Front combination lamp	B – B	0.1 – 2.9 mm (0.004 – 0.114 in)	—
Bumper fascia assembly – Front fender	C – C	0.0 – 0.8 mm (0.000 – 0.031 in)	(–0.3) – (+1.7) mm [(–0.012) – (+0.067) in]

# REAR BUMPER

< REMOVAL AND INSTALLATION >

## REAR BUMPER

Exploded View

INFOID:000000009650488

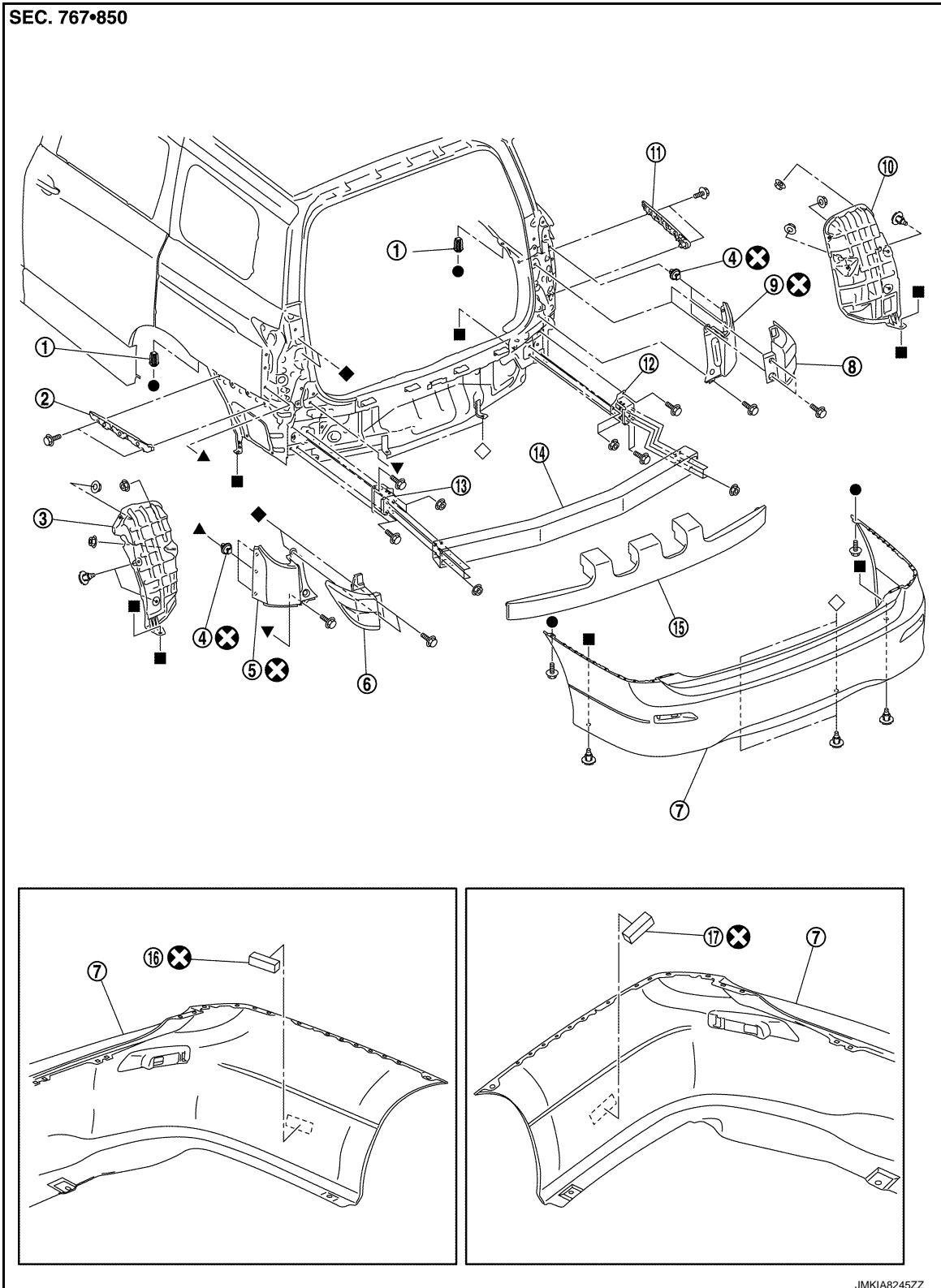

A  
B  
C  
D  
E  
F  
G  
H  
I  
J  
EXT  
L  
M  
N  
O  
P

- |                           |                                      |                                      |
|---------------------------|--------------------------------------|--------------------------------------|
| 1. Screw grommet          | 2. Bumper side bracket LH            | 3. Rear bumper closing LH            |
| 4. Clip                   | 5. Sight shield assembly LH          | 6. Rear combination lamp assembly LH |
| 7. Bumper fascia assembly | 8. Rear combination lamp assembly RH | 9. Sight shield assembly RH          |

JMK1A8245ZZ

# REAR BUMPER

## < REMOVAL AND INSTALLATION >

- |                                |                                |                            |
|--------------------------------|--------------------------------|----------------------------|
| 10. Rear bumper closing RH     | 11. Bumper side bracket RH     | 12. Bumper stay RH         |
| 13. Bumper stay LH             | 14. Bumper reinforcement       | 15. Bumper energy absorber |
| 16. Rear bumper side spacer LH | 17. Rear bumper side spacer RH |                            |

⊗ : Always replace after every disassembly.

●, ▲, ▼, ◆, ■, ◇ : Indicates that the part is connected at points with same symbol in actual vehicle.

## REAR BUMPER

### REAR BUMPER : Removal and Installation

INFOID:000000009650489

#### CAUTION:

Bumper fascia is made of resin. Never apply strong force to it, and be careful to prevent contact with oil.

#### REMOVAL

1. Fully open back door.
2. Remove clips of bumper lower side.
3. Remove bumper fascia both ends fixing screws (A).

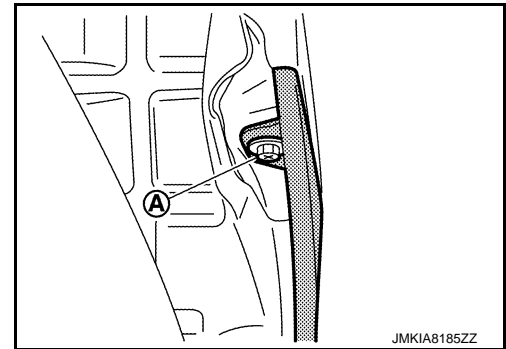

4. Pull bumper fascia assembly toward the vehicle out side as shown by the arrows in the figure, and then disengage the bumper fascia assembly from bumper side brackets (LH and RH).

#### CAUTION:

When removing bumper fascia assembly, 2 workers are required so as to prevent it from dropping.

△ : Pawl

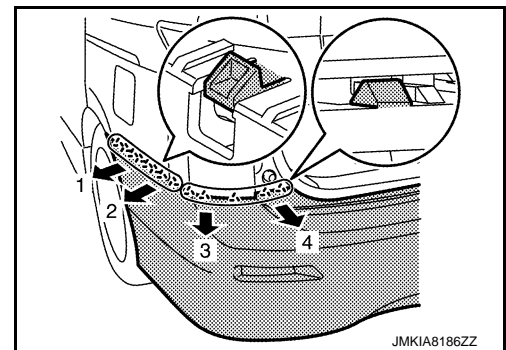

5. Remove bumper fascia assembly.
6. Remove reflex reflector (LH and RH) from bumper fascia assembly.
7. Remove bumper energy absorber.
8. Remove bumper reinforcement mounting nuts, and then remove bumper reinforcement.
9. Remove bumper stay mounting nuts and bolts, and then remove bumper stay (LH and RH).
10. Remove bumper side bracket fixing screws, and then remove bumper side bracket (LH and RH).

#### INSTALLATION

Note the following items, and then install in the reverse order of removal.

#### NOTE:

- The following table shows the specified values for checking normal installation status.



# REAR BUMPER

## < REMOVAL AND INSTALLATION >

- Fitting adjustment cannot be performed.

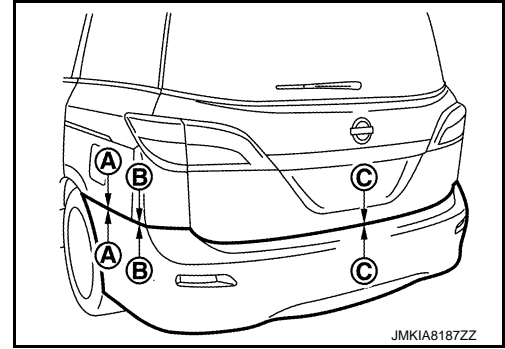

Portion		Clearance	Surface height difference
Bumper fascia assembly – Front fender	A – A	0.0 – 0.8 mm (0.000 – 0.031 in)	(-0.2) – (+1.8) mm [(-0.008) – (+0.071) in]
Bumper fascia assembly – Sight shield	B – B	0.0 – 1.2 mm (0.000 – 0.047 in)	—
Bumper fascia assembly – Back door	C – C	6.0 – 10.0 mm (0.236 – 0.394 in)	—

## REAR BUMPER CLOSING

### REAR BUMPER CLOSING : Removal and Installation

INFOID:000000009650490

#### REMOVAL

Remove rear bumper closing fixing clips, and then remove rear bumper closing.

#### INSTALLATION

Note the following item, and then install in the reverse order of removal.

#### **CAUTION:**

**When installing rear bumper closing, check that stud bolts in rear wheel house are inserted in mounting holes of rear bumper closing.**

A  
B  
C  
D  
E  
F  
G  
H  
I  
J  
EXT  
L  
M  
N  
O  
P

# FRONT GRILLE

< REMOVAL AND INSTALLATION >

## FRONT GRILLE

Exploded View

INFOID:000000009650491

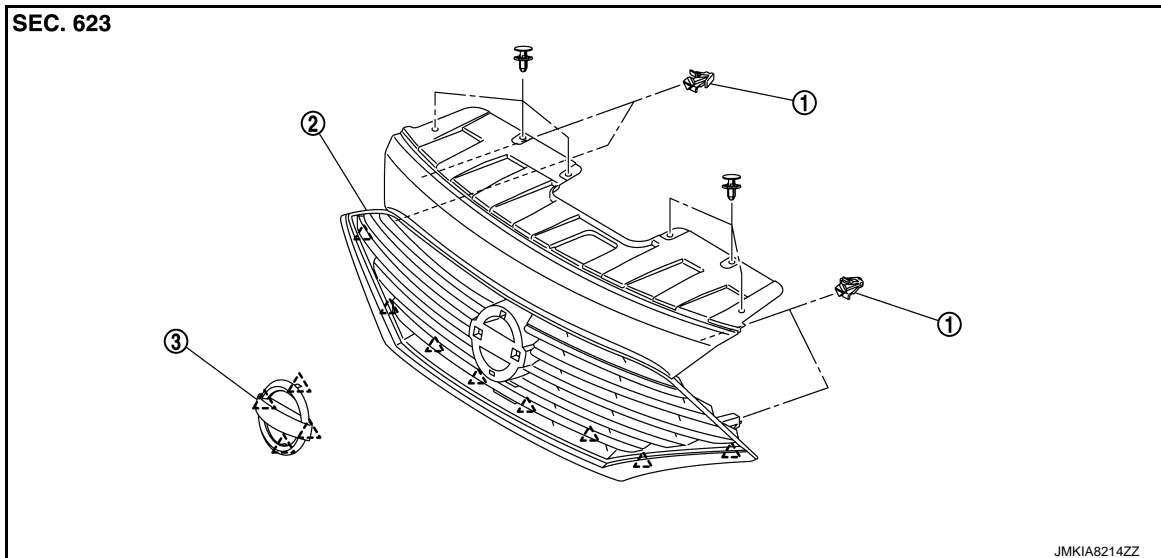

1. Clip

2. Front grille

3. Emblem

 : Pawl

## Removal and Installation

INFOID:000000009650492

### REMOVAL

1. Fully open hood assembly.
2. Remove front grille upper fixing clips (A).

**CAUTION:**

Apply a protective tape (B) on bumper fascia to protect the painted surface from damage.

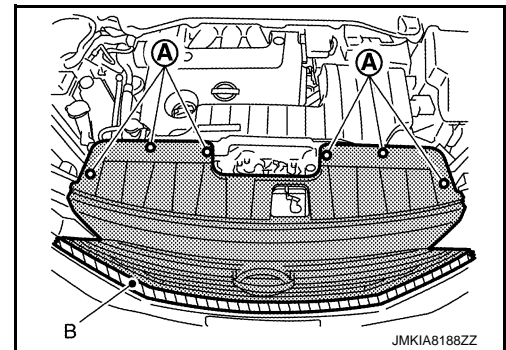

3. Insert a flat-bladed screwdriver (B) into the service hole on front surface of front grille, and then rotate front grille fixing clip (A) approximately 45 degrees to disengage fastener.

**CAUTION:**

Apply a protective tape (C) on bumper fascia to protect the painted surface from damage.

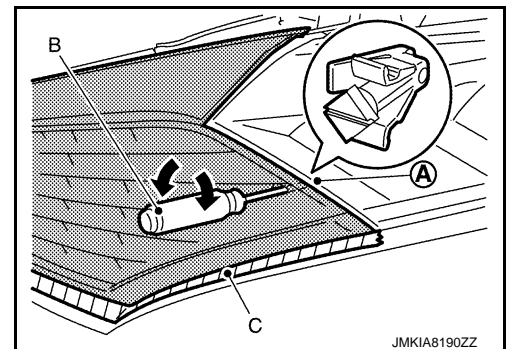

# FRONT GRILLE

## < REMOVAL AND INSTALLATION >

4. Pull front grille toward the direction shown in the figure, and then disengage front grille fixing clips.

**CAUTION:**

**Apply a protective tape (A) on bumper fascia to protect the painted surface from damage.**

 : Clip

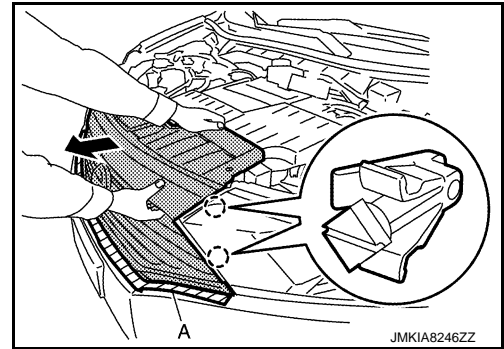

5. Disengage front grille fixing pawls from back side of front grille while pull front grille horizontally toward vehicle front, and then remove front grille.
6. Remove emblem after removing front grille.

## INSTALLATION

Install in the reverse order of removal.

A  
B  
C  
D  
E  
F  
G  
H  
I  
J  
L  
M  
N  
O  
P

EXT

# FRONT SPOILER

< REMOVAL AND INSTALLATION >

## FRONT SPOILER

Exploded View

INFOID:000000009650493

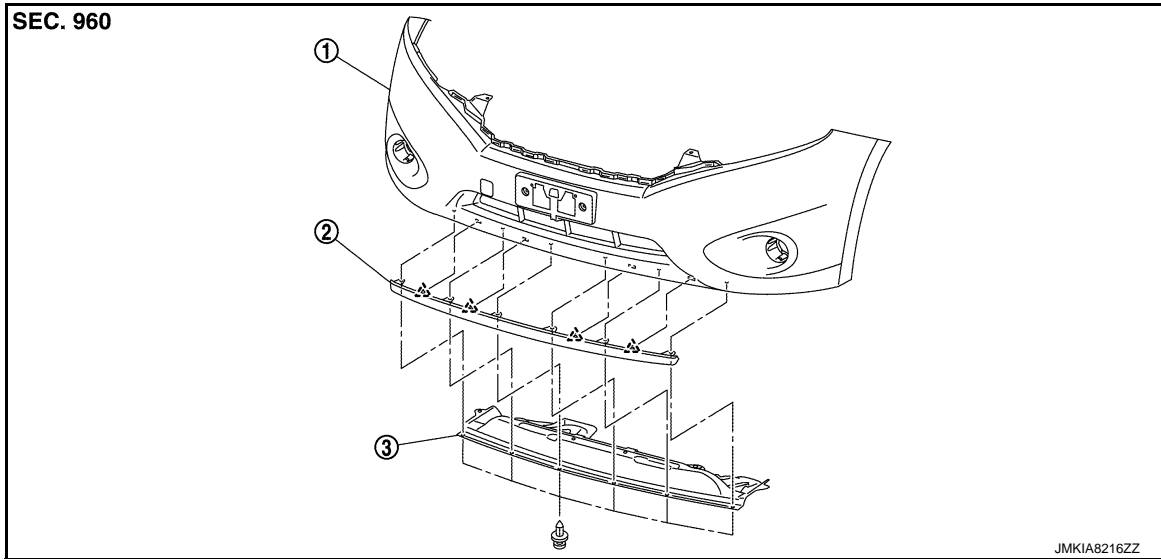

1. Front bumper fascia assembly

2. Front spoiler assembly

3. Engine under cover

 : Pawl

## Removal and Installation

INFOID:000000009650494

### REMOVAL

1. Remove engine under cover. Refer to [EXT-28, "Removal and Installation"](#).
2. Disengage fixing pawls, and then remove front spoiler.

### INSTALLATION

Install in the reverse order of removal.

# COWL TOP

< REMOVAL AND INSTALLATION >

## COWL TOP

Exploded View

INFOID:000000009650495

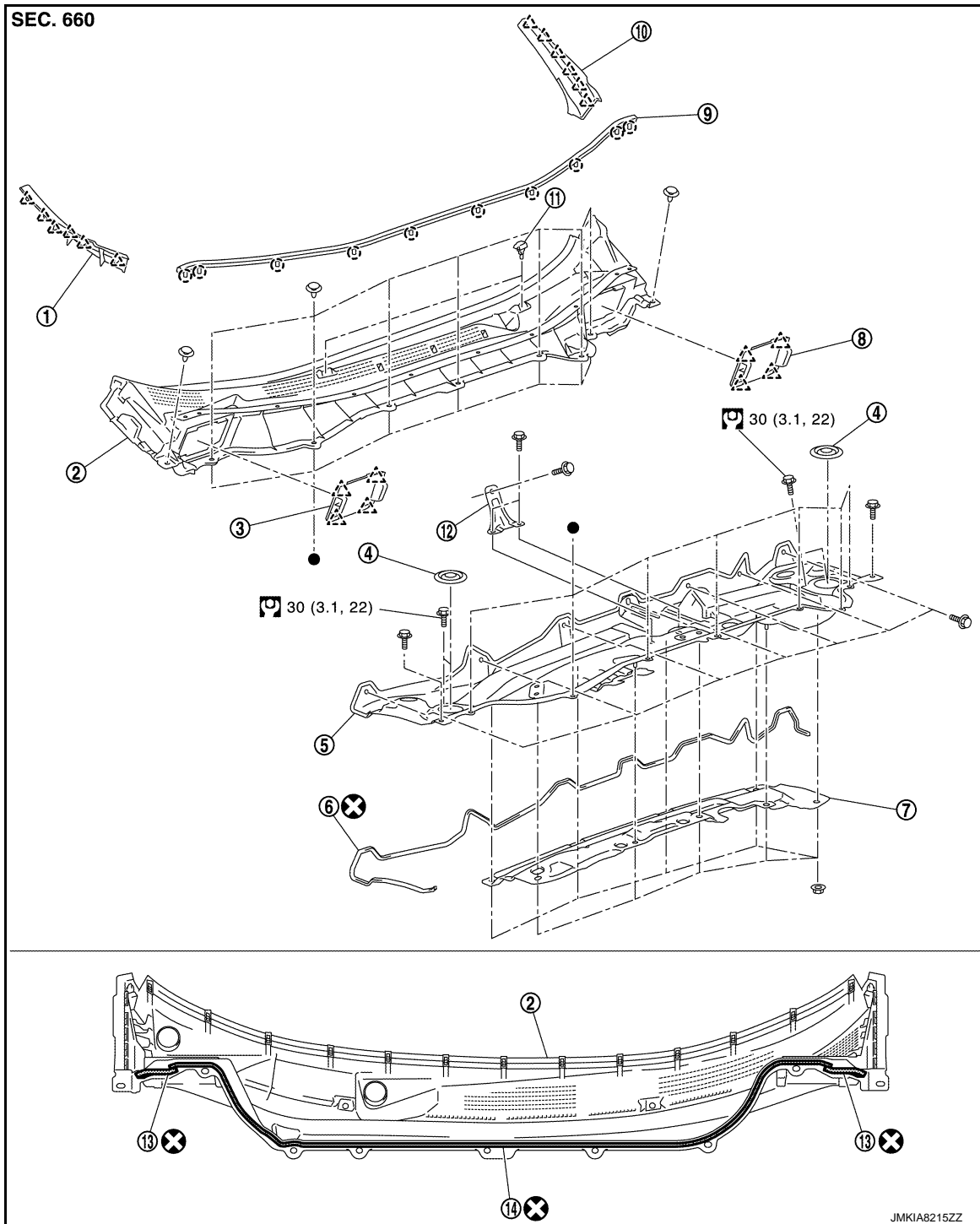

A  
B  
C  
D  
E  
F  
G  
H  
I  
J  
EXT  
L  
M  
N  
O  
P

- |                                      |                                     |                                    |
|--------------------------------------|-------------------------------------|------------------------------------|
| 1. Front fender cover RH             | 2. Cowl top cover                   | 3. Cowl top cover lid RH           |
| 4. Blind plug                        | 5. Cowl top extension               | 6. EPT seal [t: 5.0 mm (0.197 in)] |
| 7. Cowl top insulator                | 8. Cowl top cover lid LH            | 9. Cowl top cover seal             |
| 10. Front fender cover LH            | 11. Washer nozzle                   | 12. Cowl top center stay           |
| 13. EPT seal [t: 15.0 mm (0.591 in)] | 14. EPT seal [t: 3.0 mm (0.118 in)] |                                    |

⊖ : Clip

# COWL TOP

## < REMOVAL AND INSTALLATION >

 : Pawl

 : Always replace after every disassembly.

 : N·m (kg-m, ft-lb)

 : Indicates that the part is connected at points with same symbol in actual vehicle.

## Removal and Installation

INFOID:000000009650496

### REMOVAL

1. Fully open hood assembly.
2. Remove front wiper arms (LH and RH). Refer to [WW-51, "WIPER ARM : Removal and Installation"](#).
3. Disconnect front washer tube connector.
4. Remove front fender covers (LH and RH).
5. Remove cowl top cover fixing clips.
6. Pull forward to release cowl top cover from windshield glass.

#### **CAUTION:**

**When performing the procedure after removing cowl top cover, cover the lower end of windshield glass with urethaneetc.**

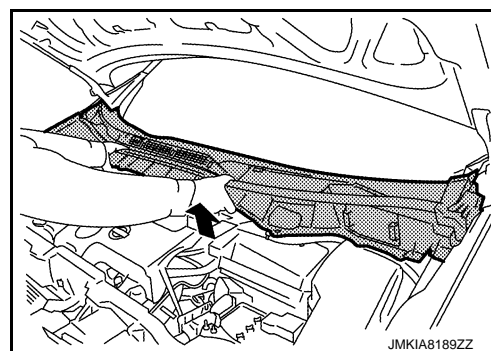

7. Remove cowl top cover.
8. Remove the following parts after removing cowl top cover.
  - EPT sealer
  - Cowl top cover seal
  - Washer tube
  - Washer nozzle (LH and RH). Refer to [WW-66, "WASHER NOZZLE : Inspection and Adjustment"](#).
9. Remove front wiper drive assembly. Refer to [WW-53, "WIPER DRIVE ASSEMBLY : Removal and Installation"](#).
10. Remove brake master cylinder reservoir tank mounting nuts, and then remove brake master cylinder reservoir. Refer to [BR-27, "Removal and Installation"](#).
11. Remove relay boxes fixing pawl, and then remove relay boxes.
12. Remove cowl top extension mounting bolts, and then remove cowl top extension.

### INSTALLATION

Note the following items, and then install in the reverse order of removal.

#### **CAUTION:**

- Clean the joint between the cowl top cover and the windshield, and then install them.
- Replace the EPT sealer on the back surface with new EPT sealer when reusing the cowl top cover.
- Remove the EPT sealer remaining on the cowl top cover using a double-sided tape remove.
- To maintain adhesion, never wash the vehicle within 24 hours after installation.
- Perform the stop position adjustment at the installation of the front wiper arms. Refer to [WW-52, "WIPER ARM : Adjustment"](#).

# FENDER PROTECTOR

< REMOVAL AND INSTALLATION >

## FENDER PROTECTOR

Exploded View

INFOID:000000009650497

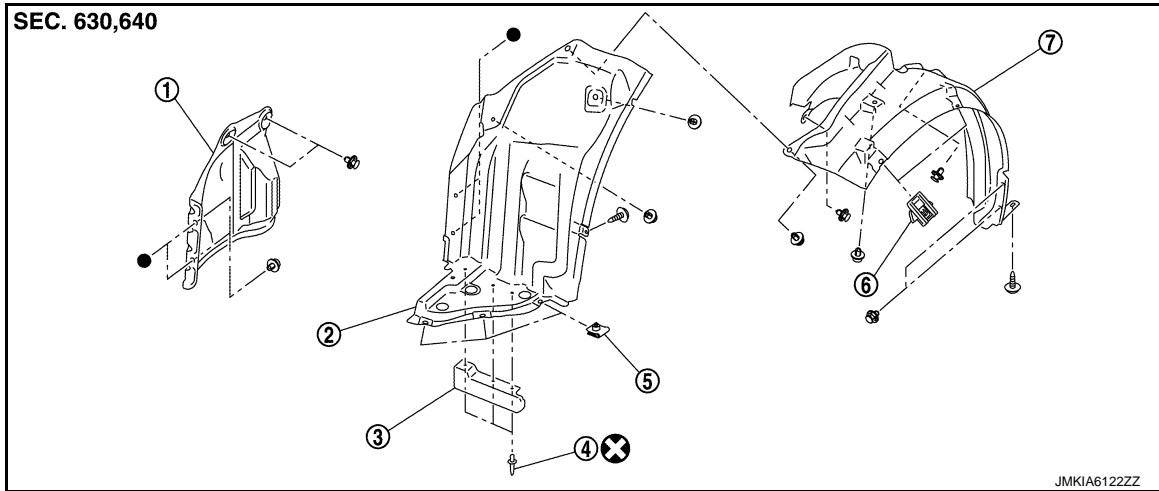

- |                            |                             |                |
|----------------------------|-----------------------------|----------------|
| 1. Splash guard            | 2. Fender protector (front) | 3. Air guide   |
| 4. Rivet                   | 5. U-nut                    | 6. Fender clip |
| 7. Fender protector (rear) |                             |                |

⊗ : Always replace after every disassembly.

● : Indicates that the part is connected at points with same symbol in actual vehicle.

## Removal and Installation

INFOID:000000009650498

### REMOVAL

1. Remove splash guard fixing clips, and then remove splash guard.
2. Remove fender protector (rear) fixing clips, screw, and fender clips, and then remove fender protector (rear).
3. Remove fender protector (front) fixing clips and screws, and then remove fender protector (front).
4. Remove air guide from fender protector (front).

### CAUTION:

#### Removal of rivet.

Grind the head of rivet with a drill [bit of  $\phi 4.5 - 5.0$  mm ( $\phi 0.177 - 0.197$  in)] and then remove the bumper brace.

### INSTALLATION

Note the following item, and then install in the reverse order of removal.

#### NOTE:

Securely crimp the bumper brace with the bumper fascia assembly with a hand riveter.

Size of rivet	
Prepared hole diameter	$\phi 5.1 - 5.3$ mm ( $\phi 0.201 - 0.209$ in)
Used rivet head diameter	$\phi 16.0$ mm ( $\phi 0.630$ in)
Crimping thickness	$0.5 - 6.4$ mm ( $0.020 - 0.252$ in)

# SIDE PROTECT MOLDING

< REMOVAL AND INSTALLATION >

## SIDE PROTECT MOLDING

Exploded View

INFOID:000000009650499

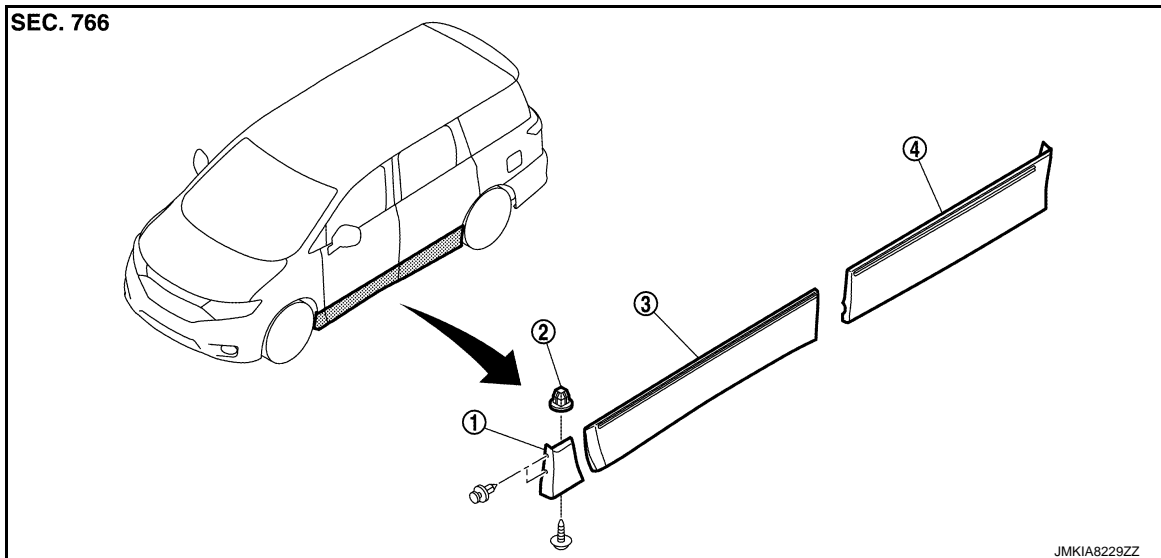

1. Fender protect molding
2. Screw grommet
3. Front door protect molding
4. Slide door protect molding

## FENDER PROTECT MOLDING

### FENDER PROTECT MOLDING : Removal and Installation

INFOID:000000009650500

#### REMOVAL

1. Remove fender protect molding fixing clips and screw.
2. Remove clips from fender protect molding back side with a remover tool (A).

**CAUTION:**

Apply protective tape (B) on the part to protect it from damage.

 : Clip

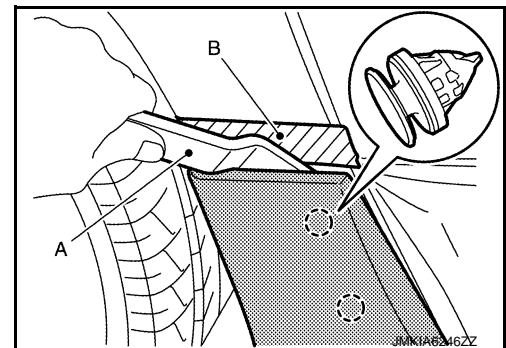

3. Remove fender protect molding.

#### INSTALLATION

Note the following items, and then install in the reverse order of removal.

**CAUTION:**

- Degrease mounting surface of fender protect molding.



# SIDE PROTECT MOLDING

## < REMOVAL AND INSTALLATION >

- Apply new double-sided tape as shown in the figure.

Double-sided tape [t: 1.2 mm (0.047 in)]

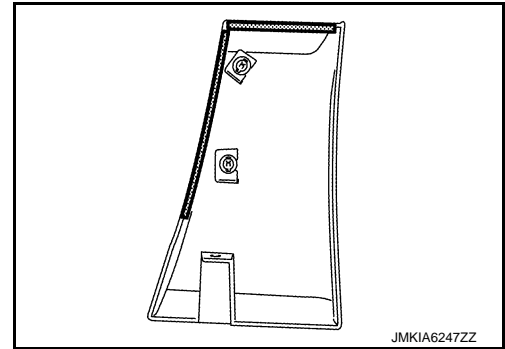

- Never wash the vehicle within 24 hours so as to keep adhesive.

## FRONT DOOR PROTECT MOLDING

### FRONT DOOR PROTECT MOLDING : Removal and Installation

INFOID:000000009650501

#### REMOVAL

##### **CAUTION:**

When removing front door protect molding, remove molding and bracket separately.

1. Fully open front door.
2. Remove front door protect molding fixing screws (A).

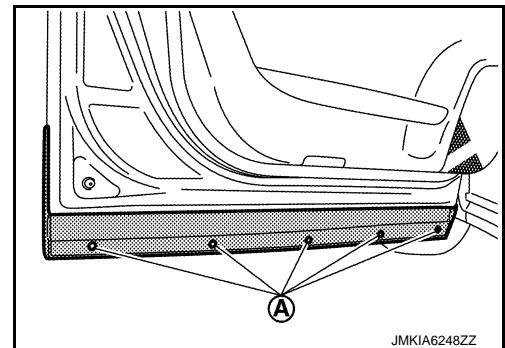

3. Pull lower portion of front door protect molding toward vehicle outer, disengage clips while peeling double-sided tape, and then remove front door protect molding.

 : Clip

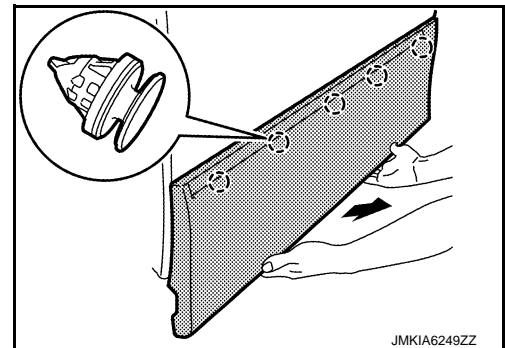

4. Remove front door protect molding bracket.

#### INSTALLATION

Note the following items, and then install in the reverse order of removal.

##### **CAUTION:**

- Degrease mounting surface of front door protect molding.

A  
B  
C  
D  
E  
F  
G  
H  
I  
J  
EXT  
L  
M  
N  
O  
P

# SIDE PROTECT MOLDING

## < REMOVAL AND INSTALLATION >

- When reusing removed protect molding, apply new double-sided tape as shown in the figure, assemble molding (1) and bracket (2), and then install.

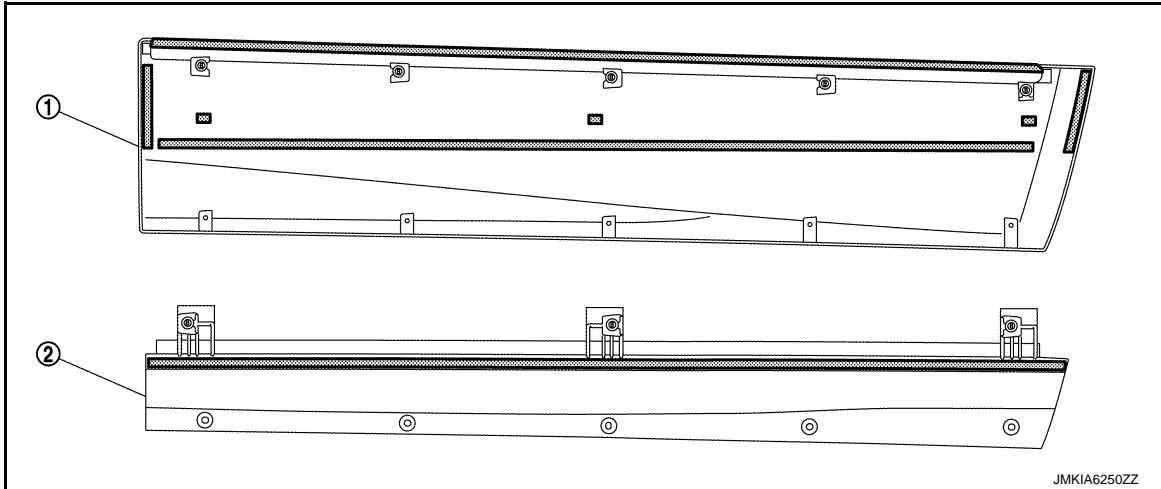

1. Front door protect molding
  2. Front door protect molding bracket
- Double-sided tape [t: 1.2 mm (0.047 in)]

- **Never wash the vehicle within 24 hours so as to keep adhesive.**

## SLIDE DOOR PROTECT MOLDING

### SLIDE DOOR PROTECT MOLDING : Removal and Installation

INFOID:000000009650502

#### REMOVAL

#### **CAUTION:**

**When removing slide door protect molding, remove molding and bracket separately.**

1. Fully open slide door.
2. Remove slide door protect molding fixing screws (A).

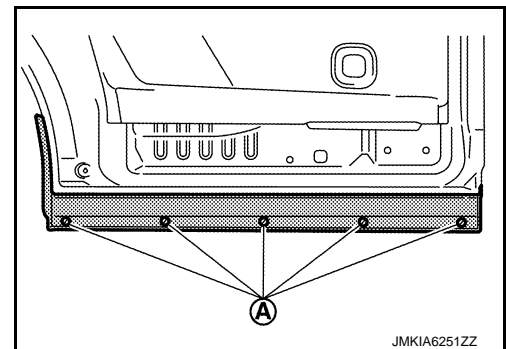

3. Pull lower portion of slide door protect molding toward vehicle outer, disengage clips while peeling double-sided tape, and then remove slide door protect molding.

 : Clip

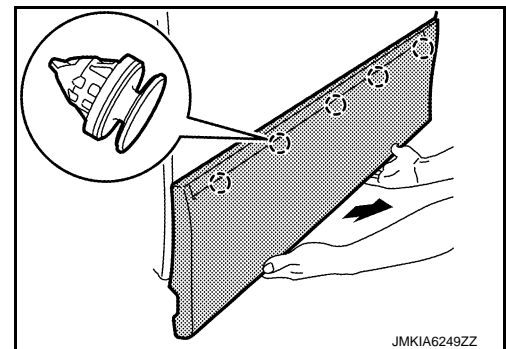

4. Remove slide door protect molding bracket.

#### INSTALLATION

Note the following items, and then install in the reverse order of removal.

#### **CAUTION:**

## SIDE PROTECT MOLDING

### < REMOVAL AND INSTALLATION >

- Degrease mounting surface of slide door protect molding.
- When reusing removed protect molding, apply new double-sided tape as shown in the figure, assemble molding (1) and bracket (2), and then install.

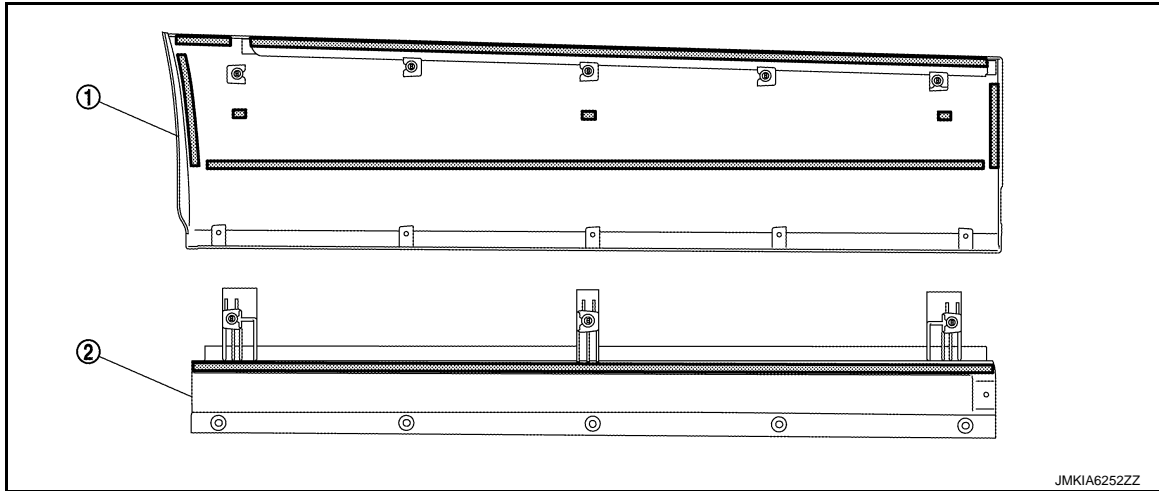

1. Slide door protect molding      2. Slide door protect molding bracket  
Double-sided tape [t: 1.2 mm (0.047 in)]

- **Never wash the vehicle within 24 hours so as to keep adhesive.**

A  
B  
C  
D  
E  
F  
G  
H  
I  
J  
L  
M  
N  
O  
P

EXT

# FLOOR SIDE FAIRING

< REMOVAL AND INSTALLATION >

## FLOOR SIDE FAIRING

Exploded View

INFOID:000000009650503

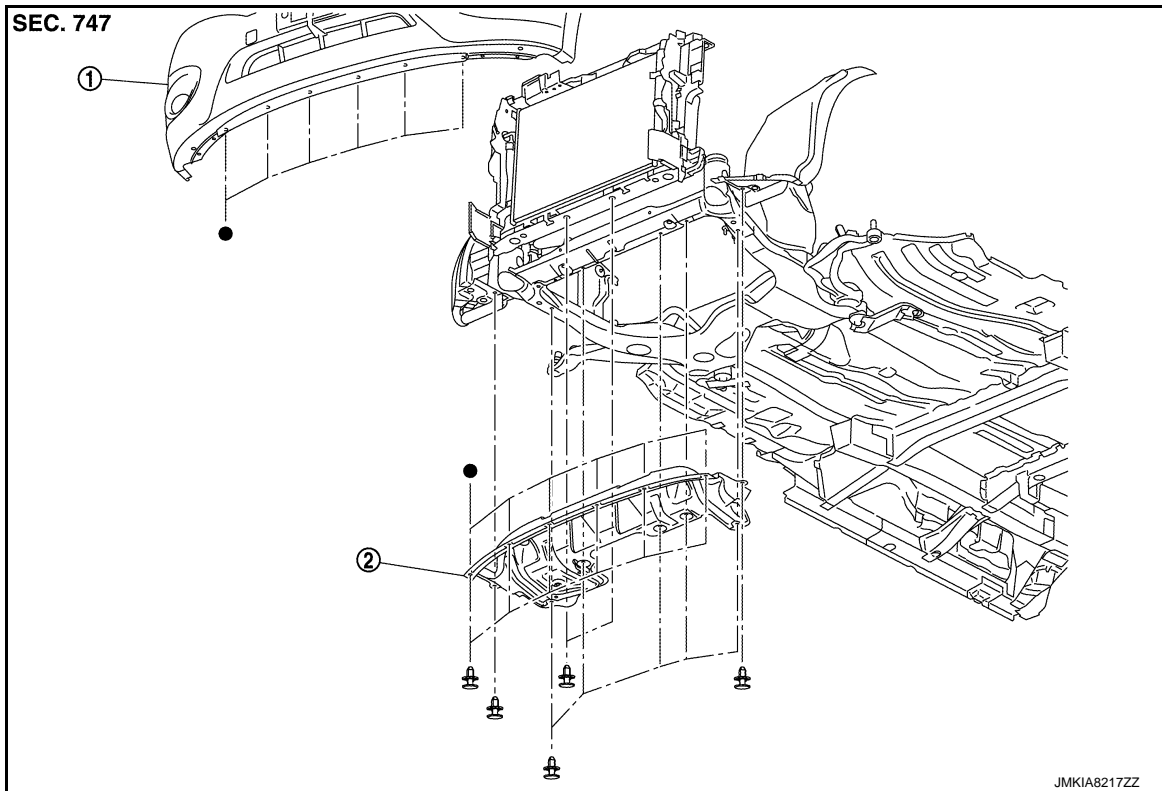

1. Front bumper fascia assembly      2. Engine under cover

● : Indicates that the part is connected at points with same symbol in actual vehicle.

### Removal and Installation

INFOID:000000009650504

#### REMOVAL

Remove engine under cover fixing clips, and then remove engine under cover.

#### INSTALLATION

Install in the reverse order of removal.

# ROOF SIDE MOLDING

< REMOVAL AND INSTALLATION >

## ROOF SIDE MOLDING

Exploded View

INFOID:000000009650505

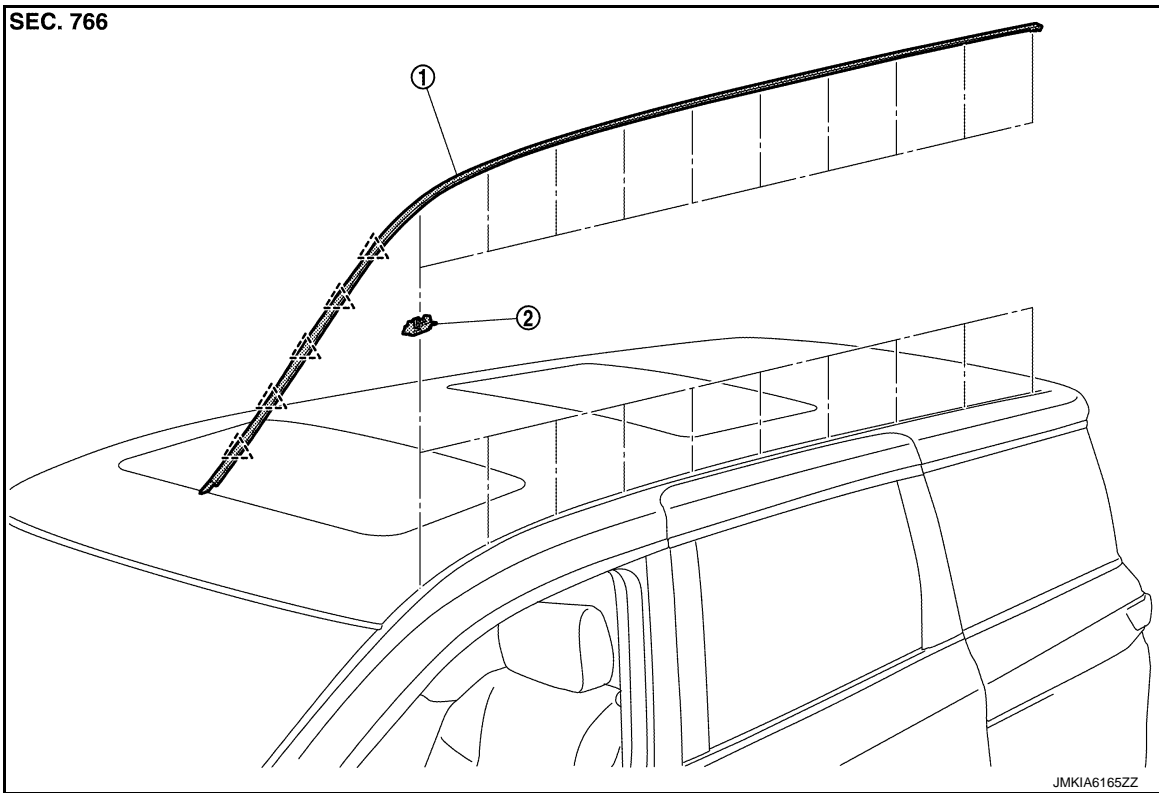

1. Roof side molding

2. Roof side molding clip

 : Pawl

## Removal and Installation

INFOID:000000009650506

EXT

### REMOVAL

Roof side molding

1. Remove front fender cover (LH and RH). Refer to [EXT-21, "Exploded View"](#).
2. Disengage roof side molding fixing pawls from front end.

 : Pawl

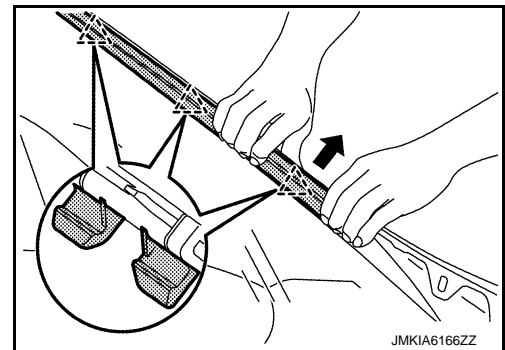

# ROOF SIDE MOLDING

## < REMOVAL AND INSTALLATION >

3. Twist and pull up to upper side, and then remove roof side molding.

**CAUTION:**

Never pull the roof side molding strongly.

 : Pawl

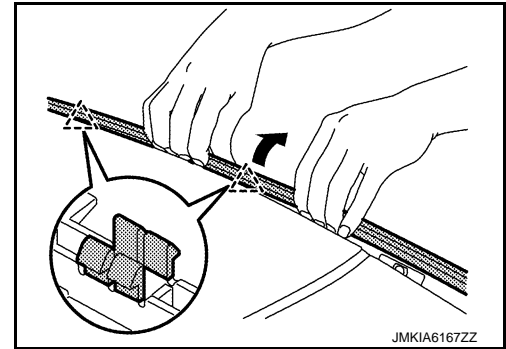

## INSTALLATION

Roof side molding

Note the following item, and then install in the reverse order of removal.

**CAUTION:**

When installing, check that roof side molding and installation guide pawl are aligned normally, and then press in from rear end toward front end.

 : Vehicle front

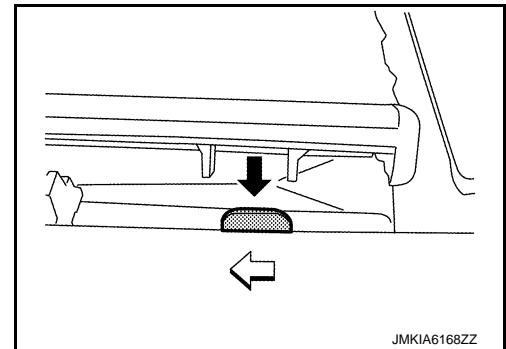

## REMOVAL AND INSTALLATION OF ROOF SIDE MOLDING CLIP

### REMOVAL

1. Remove roof side molding.
2. Heat adhesive tape interface using a dryer, and then peel roof side molding clips (body side) using long-nose pliers.

**CAUTION:**

Be careful not to damage the body.

### INSTALLATION

1. Clean tape removed surface with a shop cloth soaked in white gasoline or IPA.
2. Use two-part epoxy adhesive.

**Adhesive** : 3M-weld DP-105 or equivalent

3. Apply adhesive evenly to clip tape surface.

**Thickness** : Approximately 0.5 mm (0.020 in)

4. Position applied parts to the proper location, and then sufficiently press-fit until the adhesive protrudes to tape side.

**Press-fit limit** : 19.6 N× 2 seconds

5. Tape roof side molding clips after press fit, and temporarily hold it for specified time based on the following.

**5 to 10°C (41 to 50°F)** : 1 hour or more

**11 to 23°C (52 to 73°F)** : 30 minutes or more

**24°C or more (75°F or more)** : 15 minutes or more

**CAUTION:**

## ROOF SIDE MOLDING

### < REMOVAL AND INSTALLATION >

---

- Use double-sided tape after hardening for roof side molding clips.
- Securely insert molding rear end cap onto roof rear end cutout (installation standard).
- When installing roof side molding of windshield glass portion, check that body side molding fastener is securely inserted and then press in.
- Never wash the vehicle within 24 hours so as to keep adhesive.

A

B

C

D

E

F

G

H

I

J

EXT

L

M

N

O

P

# ROOF RAIL

< REMOVAL AND INSTALLATION >

## ROOF RAIL

Exploded View

INFOID:000000009650507

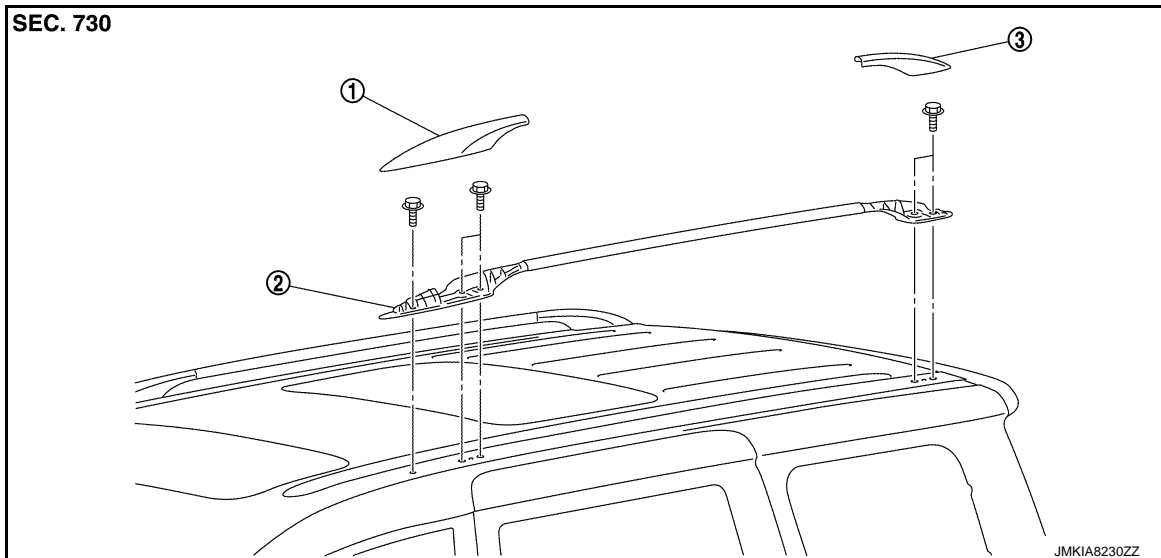

1. Front roof rail cover

2. Roof rail assembly

3. Rear roof rail cover

## Removal and Installation

INFOID:000000009650508

### REMOVAL

1. Remove front roof rail cover with remover tool (A).

**CAUTION:**

Apply protective tape (B) around the roof rail.

 : Pawl

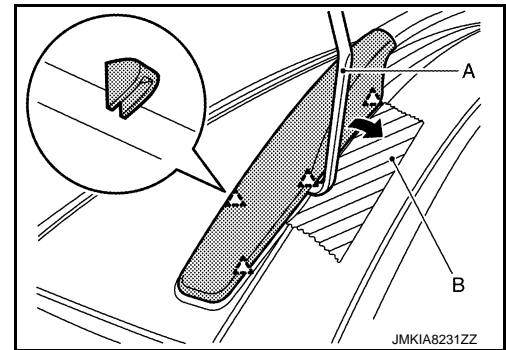

2. Remove rear roof rail cover with remover tool (A).

**CAUTION:**

Apply protective tape (B) around the roof rail.

 : Pawl

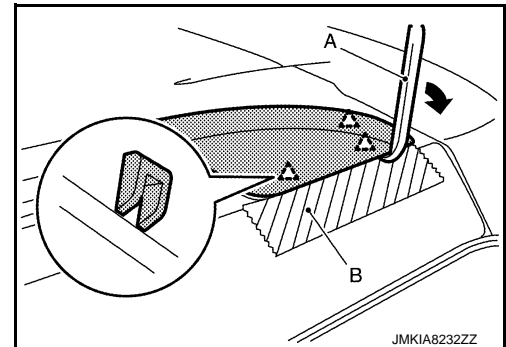

3. Remove roof rail mounting bolts, and then remove roof rail assembly.

### INSTALLATION

Install in the reverse order of removal.



# DOOR OUTSIDE MOLDING

< REMOVAL AND INSTALLATION >

## DOOR OUTSIDE MOLDING

Exploded View

INFOID:000000009650509

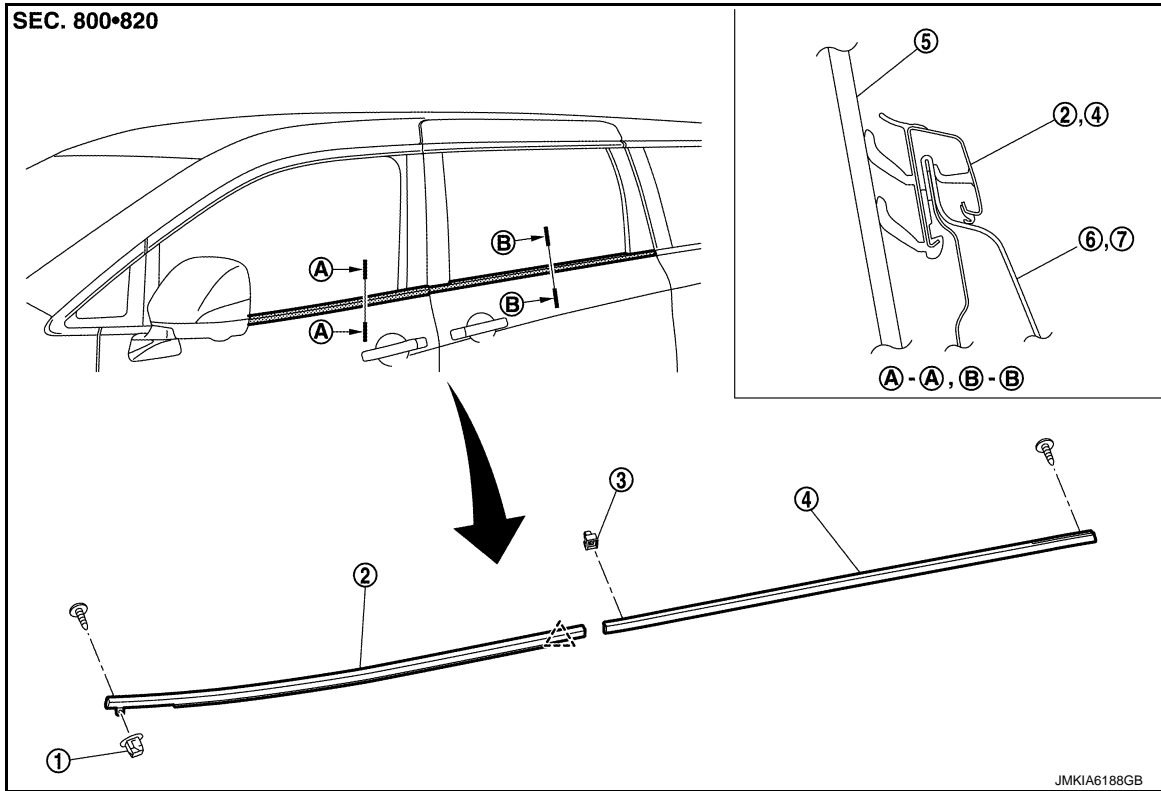

- |                               |                               |                     |
|-------------------------------|-------------------------------|---------------------|
| 1. Screw grommet              | 2. Front door outside molding | 3. Clip             |
| 4. Slide door outside molding | 5. Door glass                 | 6. Front door panel |
| 7. Slide door panel           |                               |                     |

 : Pawl

### Removal and Installation

INFOID:000000009650510

#### FRONT DOOR OUTSIDE MOLDING

Removal

1. Fully open front door glass.
2. Remove front door outside molding fixing screw (A).

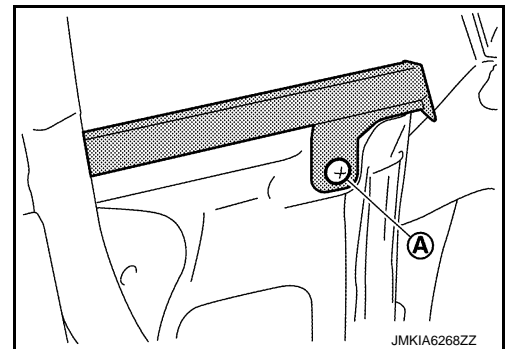

A  
B  
C  
D  
E  
F  
G  
H  
I  
J  
EXT  
L  
M  
N  
O  
P

## DOOR OUTSIDE MOLDING

### < REMOVAL AND INSTALLATION >

3. Insert a remover tool (A) into lower space.
4. Disengage pawls of fixing front door outside molding with flated-blade screwdriver (B).

**CAUTION:**

Apply protection tape (C) around outer circumference of front door.

 : Pawl

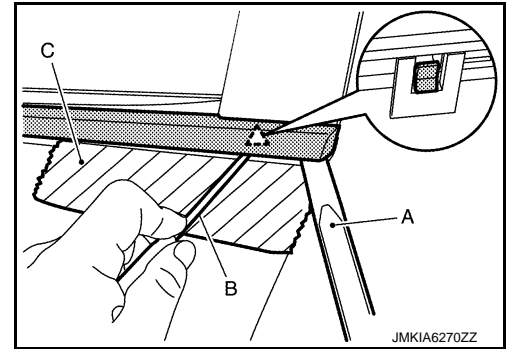

5. Twist door outside molding toward the outside of the vehicle, and then lift up and remove it while disengaging the pawls.

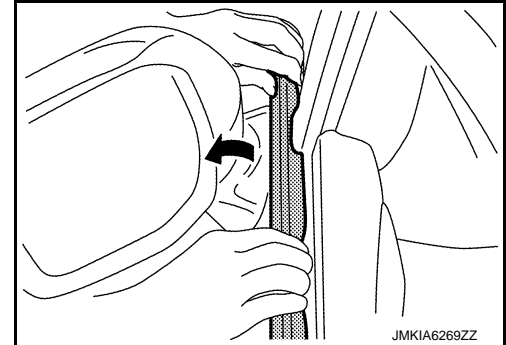

### Installation

Note the following item, and then install in the reverse order of removal.

**CAUTION:**

When installing front door outside molding, check that pawl (1) is accurately aligned with mounting hole (2), then press in.

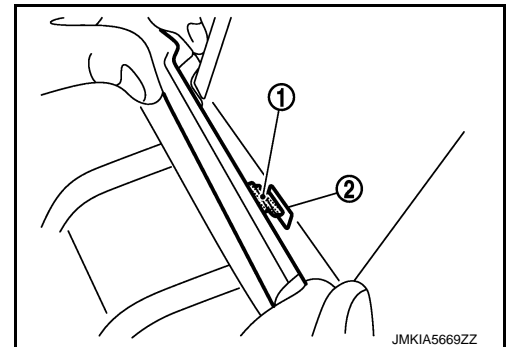

## SLIDE DOOR OUTSIDE MOLDING

### Removal

1. Fully open slide door glass.
2. Remove slide door corner outer cover. Refer to [EXT-36. "Removal and Installation"](#).
3. Remove slide door outside molding fixing screw (A).

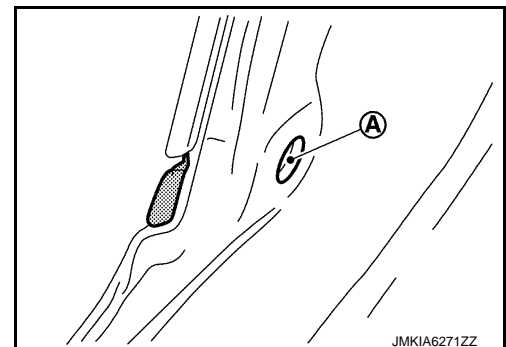

4. Lift up slide door outside molding toward vehicle upper to remove.

# DOOR OUTSIDE MOLDING

## < REMOVAL AND INSTALLATION >

5. Disengage pawl of fixing rear door outside molding with flated-blade screwdriver.

 : Pawl

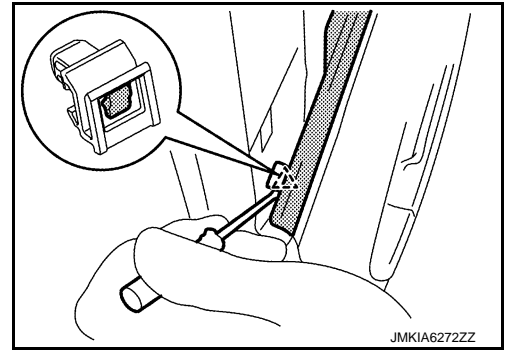

### Installation

Install in the reverse order of removal.

A  
B  
C  
D  
E  
F  
G  
H  
I  
J  
L  
M  
N  
O  
P

EXT

# DOOR SASH MOLDING

< REMOVAL AND INSTALLATION >

## DOOR SASH MOLDING

Exploded View

INFOID:000000009650511

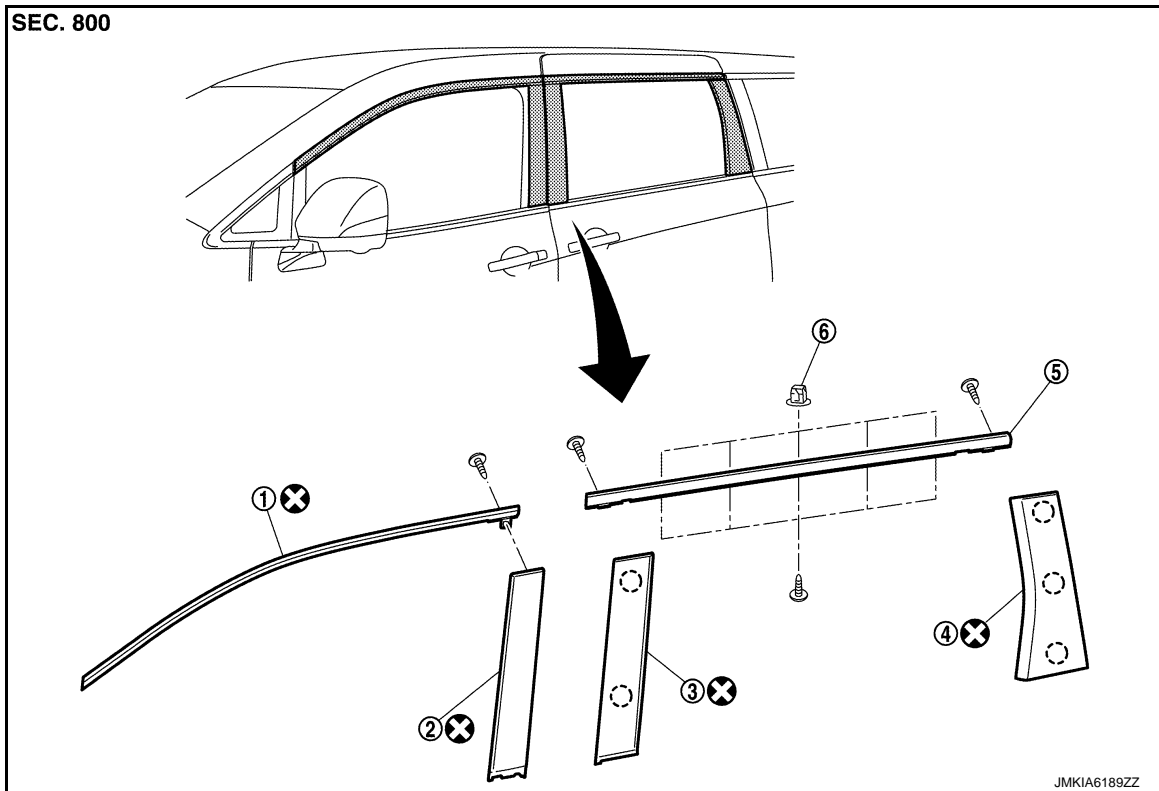

- |                                  |                            |                          |
|----------------------------------|----------------------------|--------------------------|
| 1. Front door sash molding       | 2. Front door sash cover   | 3. Slide door sash cover |
| 4. Slide door corner outer cover | 5. Slide door sash molding | 6. Screw grommet         |

○ : Clip

⊗ : Always replace after every disassembly.

## Removal and Installation

INFOID:000000009650512

### FRONT DOOR SASH MOLDING

#### Removal

1. Remove front door outside molding. Refer to [EXT-33, "Removal and Installation"](#).
2. Remove front door sash cover.
3. Disengage front door sash molding and door sash using a remover tool starting from vehicle rear to vehicle front. Remove front door sash molding.

#### Installation

Note the following item, and then install in the reverse order of removal.

#### **CAUTION:**

**Never reuse front door outside molding once it is removed.**

### SLIDE DOOR SASH MOLDING

#### Removal

1. Remove slide door corner outer cover.
2. Remove slide door outside molding. Refer to [EXT-33, "Removal and Installation"](#).
3. Remove slide door sash cover.
4. Remove slide door sash. Refer to [GW-32, "Removal and Installation"](#).

# DOOR SASH MOLDING

## < REMOVAL AND INSTALLATION >

5. Remove slide door upper sash. Refer to [GW-32. "Removal and Installation"](#).
6. Remove slide door sash molding fixing screw, and then remove slide door sash molding.

### Installation

Note the following items, and then install in the reverse order of removal.

#### CAUTION:

- Tighten slide door sash mounting screws in numerical order from 1 to 5.

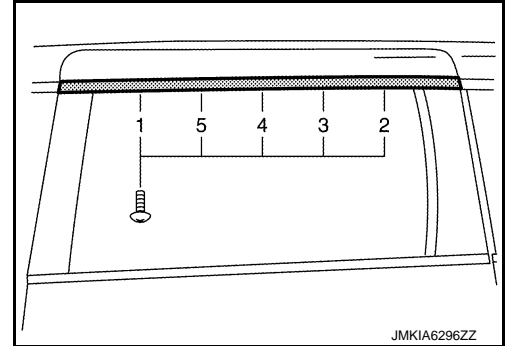

- Tighten slide door sash molding front end mounting screw (A).

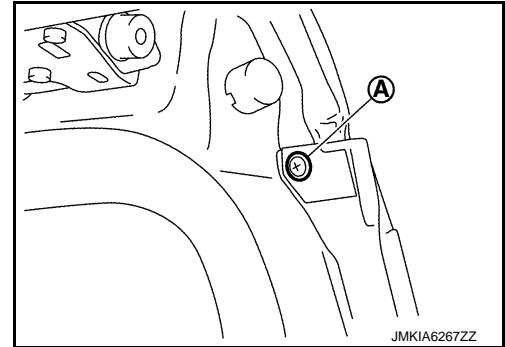

- Tighten slide door sash molding rear end mounting screw (A).

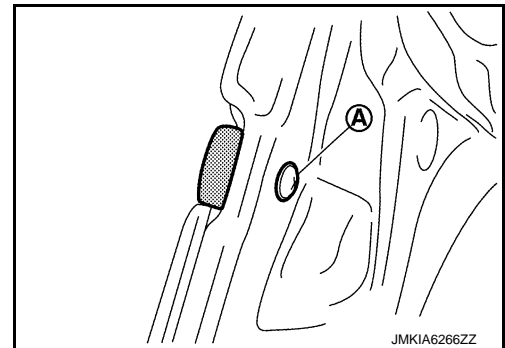

## FRONT DOOR SASH COVER

### Removal

1. Remove front door outside molding. Refer to [EXT-33. "Removal and Installation"](#).
2. Remove front door sash cover fixing screw (A).

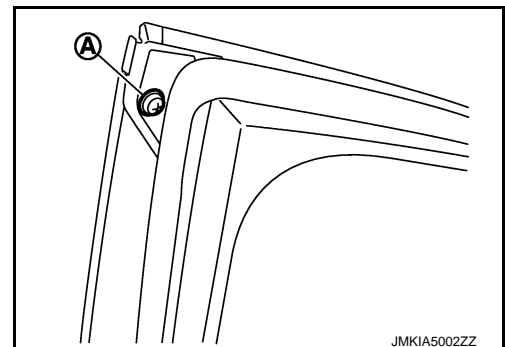

A  
B  
C  
D  
E  
F  
G  
H  
I  
J  
EXT  
L  
M  
N  
O  
P

# DOOR SASH MOLDING

## < REMOVAL AND INSTALLATION >

3. Insert a remover tool (A) between front door sash cover (1) and door panel, cut double-sided tape using a cutter (B) while lifting front door sash cover, and remove front door sash cover.

**CAUTION:**

- Use a remover tool which is made of a material that does not damage door panel.
- Never lift front door sash cover with excessive force.

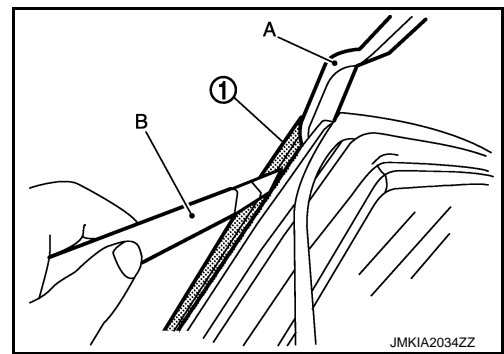

### Installation

Note the following items, and then install in the reverse order of removal.

**CAUTION:**

- Never reuse front door sash cover once it is removed.
- Never wash the vehicle within 24 hours so as to keep adhesive.

## SLIDE DOOR SASH COVER

### Removal

1. Remove slide door outside molding. Refer to [EXT-33. "Removal and Installation"](#).
2. Insert a remover tool (A) between slide door sash cover and door panel, cut double-sided tape using a cutter (B) while lifting slide door sash cover.

**CAUTION:**

- Use a remover tool which is made of a material that does not damage door panel.
- Never lift rear door sash cover with excessive force.

3. Disengage slide door sash cover fixing clips, and then remove slide door sash cover.

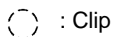

: Clip

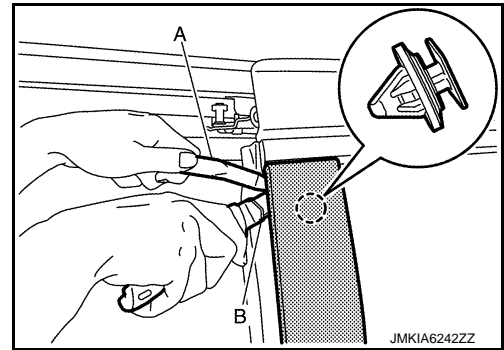

### Installation

Note the following items, and install in the reverse order of removal.

**CAUTION:**

- Never reuse slide door sash cover once it is removed.
- Never wash the vehicle within 24 hours so as to keep adhesive.

## SLIDE DOOR CORNER OUTER COVER

### Removal

1. Insert a remover tool (A) between slide door corner outer cover and door panel, cut double-sided tape using a cutter (B) while lifting slide door corner outer cover.

**CAUTION:**

- Use a remover tool which is made of a material that does not damage door panel.
- Never lift up slide door corner outer cover with excessive force.

2. Disengage slide door corner outer cover fixing clip, and then remove slide door corner outer cover.

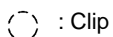

: Clip

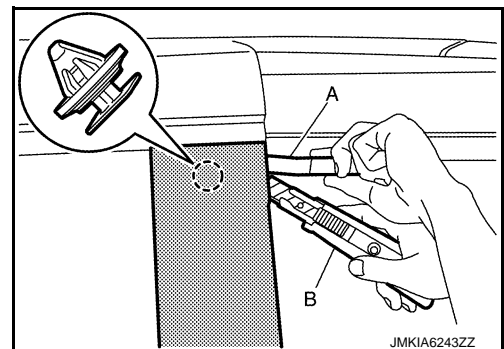

### Installation

Note the following items, and install in the reverse order of removal.

**CAUTION:**

- Never reuse slide door corner outer cover once it is removed
- Never wash the vehicle within 24 hours so as to keep adhesive.

# BACK DOOR MOLDING

< REMOVAL AND INSTALLATION >

## BACK DOOR MOLDING

Exploded View

INFOID:000000009650513

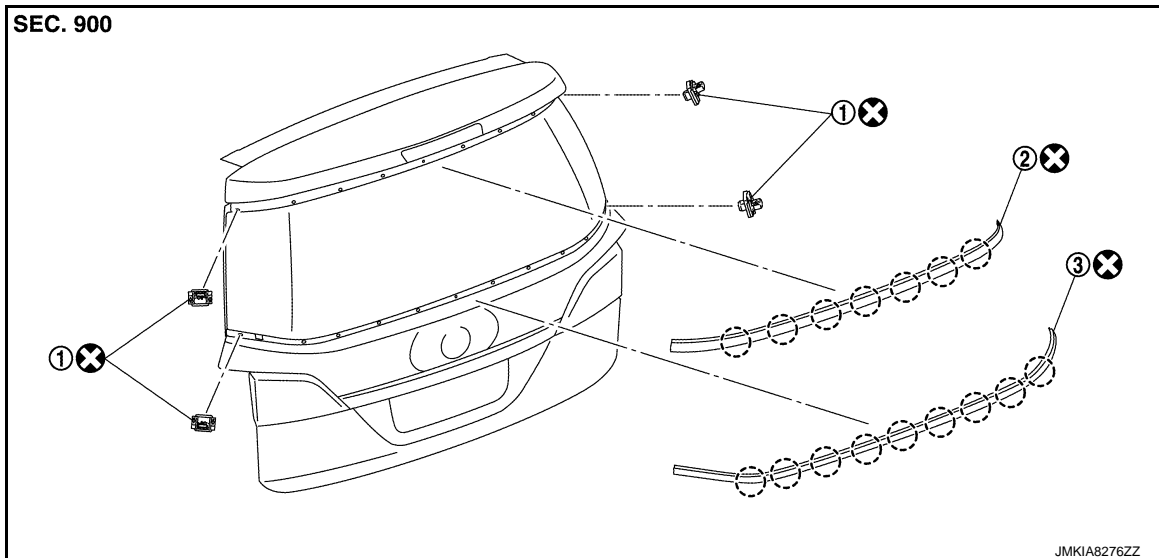

1. Fastener clip                      2. Back door upper molding                      3. Back door lower molding

○ : Clip

⊗ : Always replace after every disassembly.

## Removal and Installation

INFOID:000000009650514

### BACK DOOR UPPER MOLDING

Removal

1. Insert a remover tool between back door upper molding and back door panel and remove mounting clips of back door upper molding.

**CAUTION:**

**Be careful not to damage glass with the remover tool.**

2. Remove back door upper molding.

Installation

Note the following items, and install in the reverse order of removal.

**CAUTION:**

- Never reuse back door upper molding and faster clip once they are removed.
- Be sure to install new fastener clips on back door.
- Install fastener clip so that arrow marks on fastener clip are always facing up.

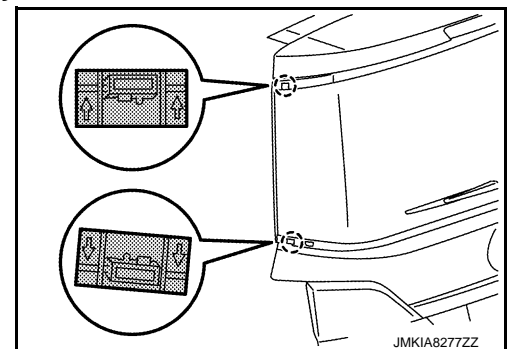

### BACK DOOR LOWER MOLDING

Removal

1. Insert a remover tool between back door lower molding and back door panel and remove mounting clips of back door lower molding.

A  
B  
C  
D  
E  
F  
G  
H  
I  
J  
EXT  
L  
M  
N  
O  
P

## BACK DOOR MOLDING

### < REMOVAL AND INSTALLATION >

---

**CAUTION:**

Be careful not to damage back door glass with the remover tool.

2. Remove back door lower molding.

Installation

Note the following items, and install in the reverse order of removal.

**CAUTION:**

- Never reuse back door lower molding and fastener clip once they are removed.
- Be sure to install new fastener clips on back door.
- Install fastener clip so that arrow marks on fastener clip are always facing down.

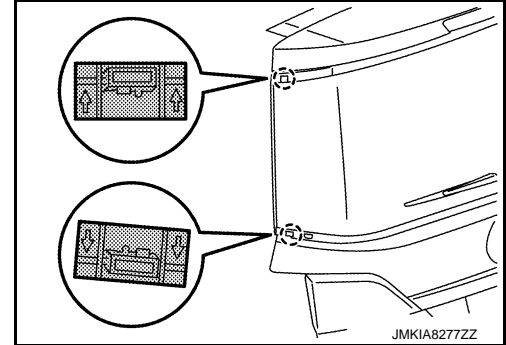



# DOOR PARTING SEAL

< REMOVAL AND INSTALLATION >

## DOOR PARTING SEAL

Exploded View

INFOID:000000009650515

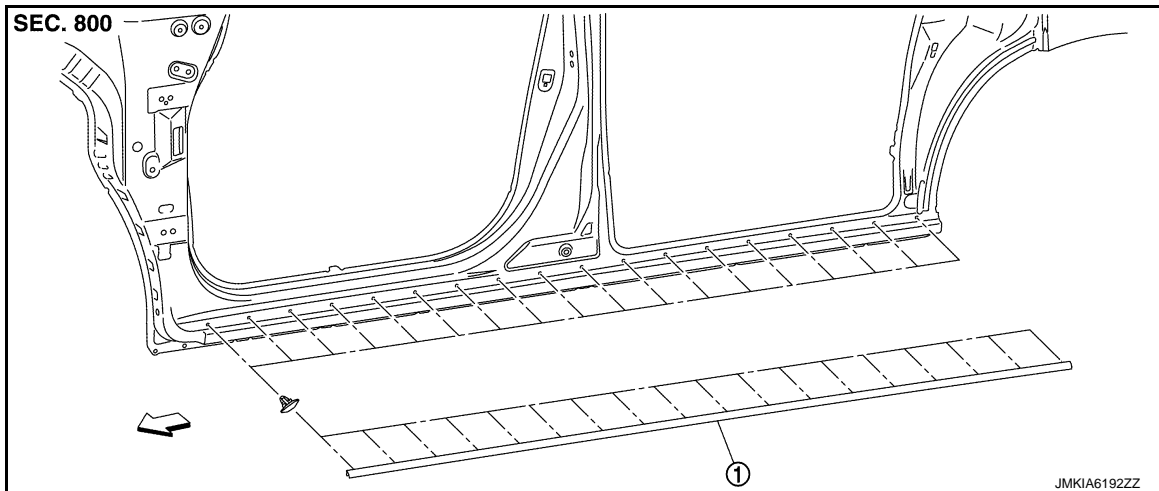

1. Door parting seal

← : Vehicle front

## Removal and Installation

INFOID:000000009650516

### REMOVAL

1. Fully open front door and slide door.
2. Disengage mounting clips of door parting seal using a remover tool (A), and then remove door parting seal.

**CAUTION:**

**Apply protective tape (B) on the part to protect it from damage.**

○ : Clip

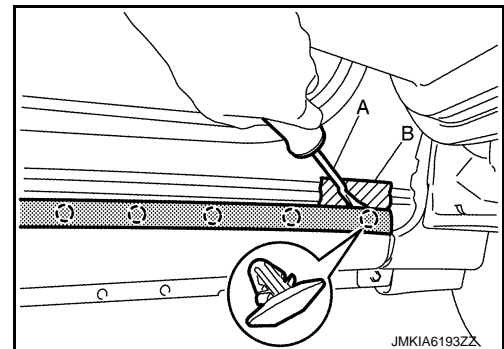

### INSTALLATION

Install in the reverse order of removal.

A  
B  
C  
D  
E  
F  
G  
H  
I  
J  
EXT  
L  
M  
N  
O  
P

# SLIDE DOOR PARTING SEAL

< REMOVAL AND INSTALLATION >

## SLIDE DOOR PARTING SEAL

Exploded View

INFOID:000000009650517

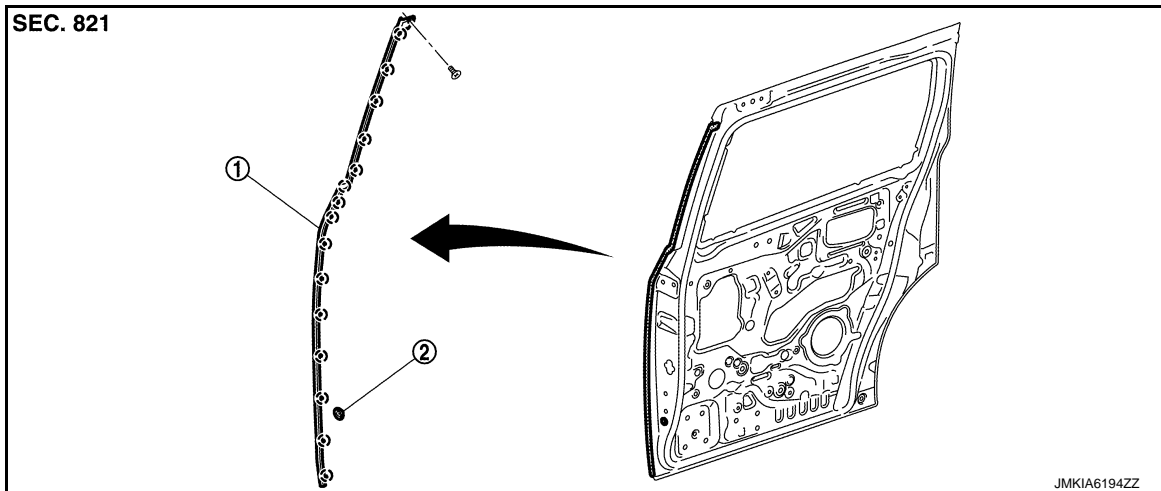

1. Slide door parting seal      2. Plug

 : Clip

## Removal and Installation

INFOID:000000009650518

### REMOVAL

1. Fully open slide door.
2. Remove slide door parting seal fixing screw.
3. Disengage slide door parting seal fixing clip, using a remover tool (A), and then remove slide door parting seal.

**CAUTION:**

**Apply protective tape (B) on the part to protect it from damage.**

 : Clip

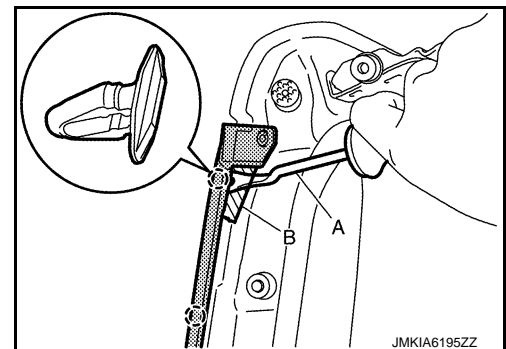

### INSTALLATION

Install in the reverse order of removal.

# SLIDE DOOR RAIL COVER

< REMOVAL AND INSTALLATION >

## SLIDE DOOR RAIL COVER

Exploded View

INFOID:000000009650519

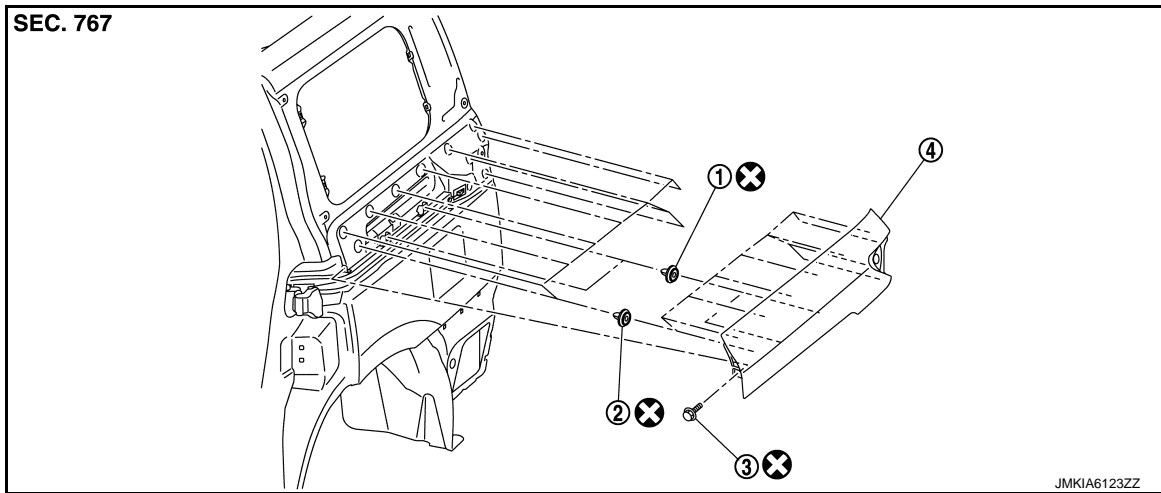

- 1. Clip
- 2. Watertight clip (With sponge washer)
- 3. Bolt
- 4. Slide door rail cover

⊗ : Always replace after every disassembly.

## Removal and Installation

INFOID:000000009650520

### REMOVAL

1. Remove rear combination lamp. Refer to [EXL-113, "Removal and Installation"](#).
2. Fully open slide door.
3. Remove slide door rail cover mounting bolt (A).

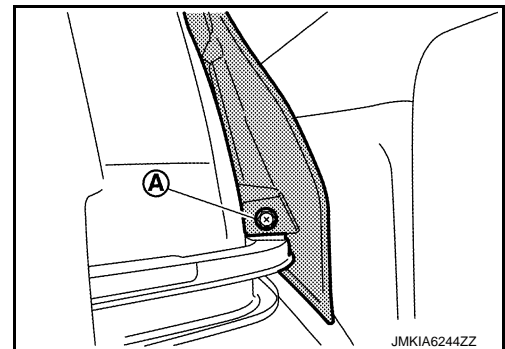

4. Fully close slide door.
5. Pull lower portion of slide door rail cover toward vehicle outer, disengage mounting clips of slide door cover, and then remove slide door rail cover.

**CAUTION:**

Apply protective tape (A) on the part to protect it from damage.

○ : Clip

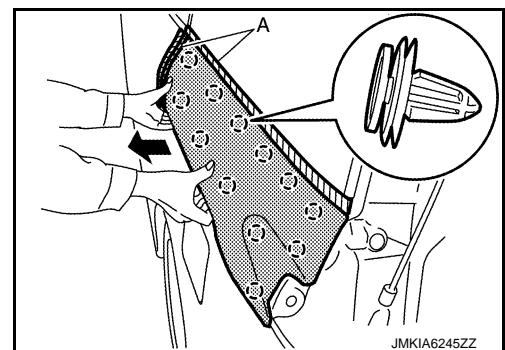

### INSTALLATION

A  
B  
C  
D  
E  
F  
G  
H  
I  
J  
EXT  
L  
M  
N  
O  
P

## SLIDE DOOR RAIL COVER

< REMOVAL AND INSTALLATION >

---

Note the following item, and then install in the reverse order of removal.

**CAUTION:**

**Never reuse clip and bolt once they are removed**

# REAR SPOILER

< REMOVAL AND INSTALLATION >

## REAR SPOILER

Exploded View

INFOID:000000009650521

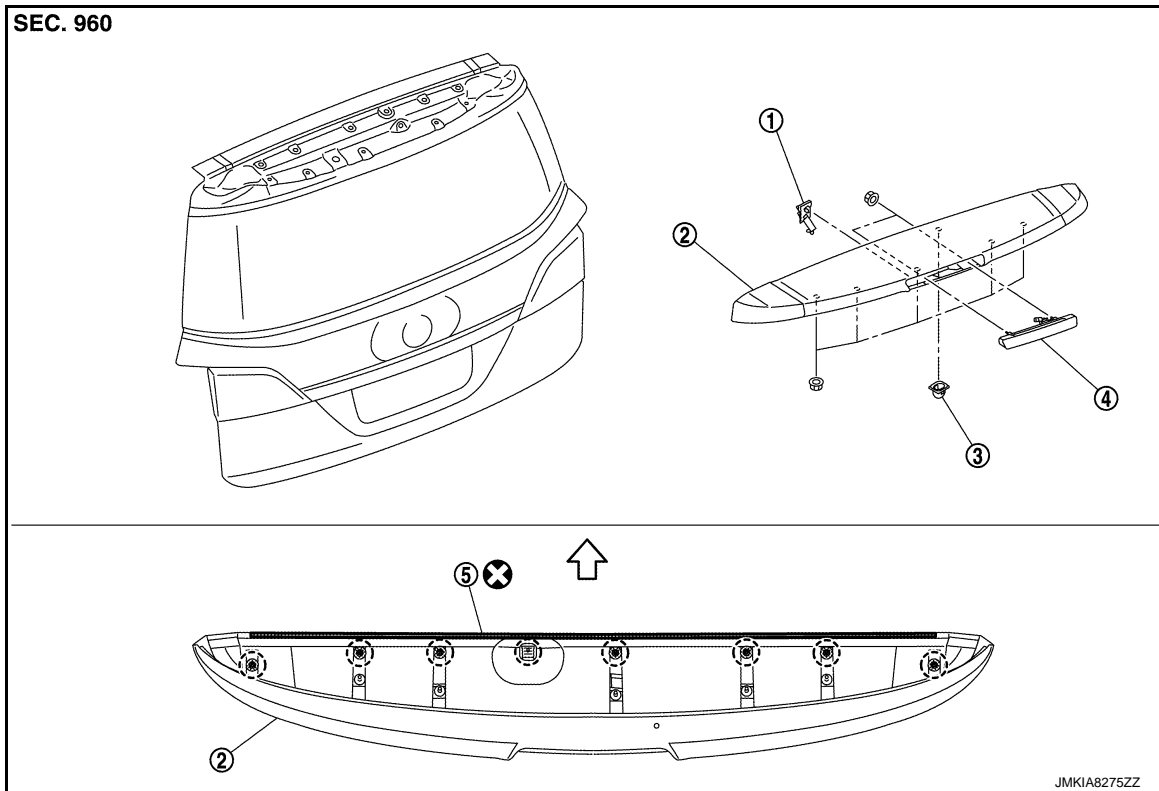

- |                           |  |            |
|---------------------------|--|------------|
| 1. Washer nozzle          | 2. Rear spoiler assembly                       | 3. Grommet |
| 4. High-mounted stop lamp | 5. Double-sided tape<br>[t: 2.0 mm (0.079 in)] |            |

 : Clip

 : Always replace after every disassembly.

 : Vehicle front

A  
B  
C  
D  
E  
F  
G  
H  
I  
J

EXT

## Removal and Installation

INFOID:000000009650522

### REMOVAL

1. Remove back door upper finisher. Refer to [INT-49, "BACK DOOR UPPER FINISHER : Removal and Installation"](#).
2. Remove rear spoiler assembly mounting nuts.
3. Insert a remover tool (A) between rear spoiler and back door panel, and then cut double-sided tape using a cutter (B) while lifting up rear spoiler.

**CAUTION:**

Apply protective tape (C) on the part to protect it from damage.

 : Clip

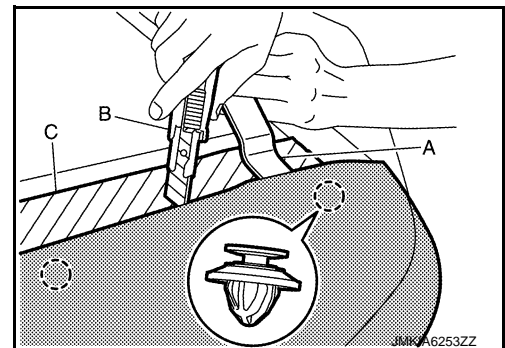

4. Disengage mounting clips of rear spoiler using a remover tool.

L  
M  
N  
O  
P

## REAR SPOILER

### < REMOVAL AND INSTALLATION >

---

5. Disconnect harness connector of high-mounted stop lamp and rear washer tube.
6. Remove rear spoiler assembly.

### INSTALLATION

Note the following items, and then install in the reverse order of removal.

#### **CAUTION:**

- **Be careful not to wind up the lips of back door upper molding.**
- **Degrease mounting surface of rear spoiler.**
- **Never wash the vehicle with in 24 hours so as to keep adhesive.**

# BACK DOOR FINISHER

< REMOVAL AND INSTALLATION >

## BACK DOOR FINISHER

Exploded View

INFOID:000000009650523

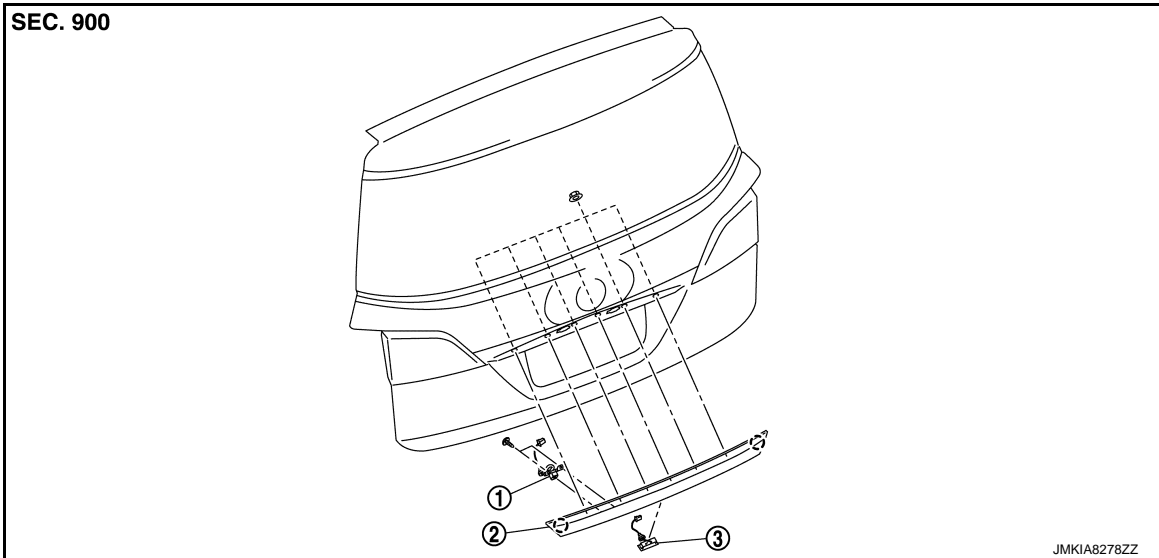

1. Rear view camera

2. Back door finisher

3. Back door opener request switch

 : Clip

## Removal and Installation

INFOID:000000009650524

### REMOVAL

1. Remove back door lower finisher. Refer to [INT-48. "BACK DOOR LOWER FINISHER : Removal and Installation"](#).
2. Remove back door finisher mounting nuts.
3. Disconnect back door opener request switch and rear view camera harness connectors.
4. Remove harness grommet.
5. Pull back door finisher diagonally downward, disengage fixing clips of back door finisher, and then remove back door finisher.

**CAUTION:**

**Never pull back door finisher strongly.**

 : Clip

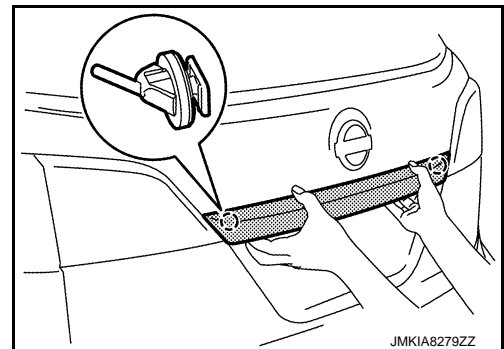

### INSTALLATION

Install in the reverse order of removal.