

SECTION **SRC**

SRS AIRBAG CONTROL SYSTEM

A
B
C
D
E
F
G
H
I
J
K
L
M
N
O
P

CONTENTS

<p>PRECAUTION 6</p> <p>PRECAUTIONS 6</p> <p style="padding-left: 20px;">Precautions for Removing Battery Terminal6</p> <p style="padding-left: 20px;">Precaution for Supplemental Restraint System (SRS) "AIR BAG" and "SEAT BELT PRE-TENSIONER"6</p> <p style="padding-left: 20px;">Service6</p> <p>SYSTEM DESCRIPTION 8</p> <p>COMPONENT PARTS 8</p> <p style="padding-left: 20px;">Component Parts Location8</p> <p>SYSTEM11</p> <p style="padding-left: 20px;">System Description 11</p> <p style="padding-left: 20px;">Schematic 14</p> <p>DIAGNOSIS SYSTEM (AIR BAG)15</p> <p style="padding-left: 20px;">Description 15</p> <p style="padding-left: 20px;">On Board Diagnosis Function 15</p> <p style="padding-left: 20px;">CONSULT Function 19</p> <p>DIAGNOSIS SYSTEM (OCCUPANT DETECTION SYSTEM)21</p> <p style="padding-left: 20px;">CONSULT Function21</p> <p>ECU DIAGNOSIS INFORMATION22</p> <p>DIAGNOSIS SENSOR UNIT22</p> <p style="padding-left: 20px;">DTC Index22</p> <p>WIRING DIAGRAM27</p> <p>SRS AIR BAG SYSTEM27</p> <p style="padding-left: 20px;">Wiring Diagram27</p> <p>BASIC INSPECTION38</p> <p>DIAGNOSIS AND REPAIR WORK FLOW38</p> <p style="padding-left: 20px;">Work Flow38</p> <p>INSPECTION AND ADJUSTMENT41</p>	<p>ADDITIONAL SERVICE WHEN REPLACING CONTROL UNIT41</p> <p style="padding-left: 20px;">ADDITIONAL SERVICE WHEN REPLACING CONTROL UNIT : Description41</p> <p style="padding-left: 20px;">ADDITIONAL SERVICE WHEN REPLACING CONTROL UNIT : Special Repair Requirement41</p> <p>ZERO POINT RESET41</p> <p style="padding-left: 20px;">ZERO POINT RESET : Description41</p> <p style="padding-left: 20px;">ZERO POINT RESET : Special Repair Requirement41</p> <p>DTC/CIRCUIT DIAGNOSIS43</p> <p>B1001, B1002, B1003, B1004, B1005 DIAGNOSIS SENSOR UNIT43</p> <p style="padding-left: 20px;">DTC Logic43</p> <p style="padding-left: 20px;">Diagnosis Procedure43</p> <p>B1006, B1007, B1008, B1009, B1010 DIAGNOSIS SENSOR UNIT44</p> <p style="padding-left: 20px;">DTC Logic44</p> <p style="padding-left: 20px;">Diagnosis Procedure44</p> <p>B1011, B1012, B1013, B1014, B1015 DIAGNOSIS SENSOR UNIT45</p> <p style="padding-left: 20px;">DTC Logic45</p> <p style="padding-left: 20px;">Diagnosis Procedure45</p> <p>B1017, B1020, B1021 OCCUPANT SENS C/U46</p> <p style="padding-left: 20px;">DTC Logic46</p> <p style="padding-left: 20px;">Diagnosis Procedure46</p> <p>B1018 OCCUPANT SENS48</p> <p style="padding-left: 20px;">DTC Logic48</p> <p style="padding-left: 20px;">Diagnosis Procedure48</p> <p>B1022 OCCUPANT SENS C/U50</p> <p style="padding-left: 20px;">DTC Logic50</p> <p style="padding-left: 20px;">Diagnosis Procedure50</p>
--	---

SRC

B1023 PASS A/B INDCTR CKT	52	B1066, B1071 PASSENGER AIR BAG MOD- ULE	76
DTC Logic	52	DTC Logic	76
Diagnosis Procedure	52	Diagnosis Procedure	76
B1025, B1032, B1048 OCS SENSOR	54	B1067, B1072 PASSENGER AIR BAG MOD- ULE	78
DTC Logic	54	DTC Logic	78
Diagnosis Procedure	54	Diagnosis Procedure	78
B1026, B1027, B1028, B1029, B1030, B1031 DIAGNOSIS SENSOR UNIT	56	B1068, B1073 PASSENGER AIR BAG MOD- ULE	80
DTC Logic	56	DTC Logic	80
Diagnosis Procedure	56	Diagnosis Procedure	80
B1033, B1034 CRASH ZONE SENSOR	57	B1074, B1075, B1076, B1077, B1078, B1079 DIAGNOSIS SENSOR UNIT	82
DTC Logic	57	DTC Logic	82
Diagnosis Procedure	57	Diagnosis Procedure	82
B1035 CRASH ZONE SENSOR	59	B1080, B1096 DRIVER AIR BAG MODULE	83
DTC Logic	59	DTC Logic	83
Diagnosis Procedure	59	Diagnosis Procedure	83
B1036 CRASH ZONE SENSOR	61	B1081 SEAT BELT PRE-TENSIONER RH	85
DTC Logic	61	DTC Logic	85
Diagnosis Procedure	61	Diagnosis Procedure	85
B1037, B1039, B1041 CRASH ZONE SEN- SOR	62	B1082 SEAT BELT PRE-TENSIONER RH	87
DTC Logic	62	DTC Logic	87
Diagnosis Procedure	62	Diagnosis Procedure	87
B1042, B1043, B1044, B1045, B1046, B1047 DIAGNOSIS SENSOR UNIT	64	B1083 SEAT BELT PRE-TENSIONER RH	89
DTC Logic	64	DTC Logic	89
Diagnosis Procedure	64	Diagnosis Procedure	89
B1049, B1054 DRIVER AIR BAG MODULE	65	B1084 SEAT BELT PRE-TENSIONER RH	91
DTC Logic	65	DTC Logic	91
Diagnosis Procedure	65	Diagnosis Procedure	91
B1050, B1055 DRIVER AIR BAG MODULE	67	B1086 SEAT BELT PRE-TENSIONER LH	93
DTC Logic	67	DTC Logic	93
Diagnosis Procedure	67	Diagnosis Procedure	93
B1051, B1056 DRIVER AIR BAG MODULE	69	B1087 SEAT BELT PRE-TENSIONER LH	95
DTC Logic	69	DTC Logic	95
Diagnosis Procedure	69	Diagnosis Procedure	95
B1052, B1057 DRIVER AIR BAG MODULE	71	B1088 SEAT BELT PRE-TENSIONER LH	97
DTC Logic	71	DTC Logic	97
Diagnosis Procedure	71	Diagnosis Procedure	97
B1058, B1059, B1060, B1061, B1062, B1063 DIAGNOSIS SENSOR UNIT	73	B1089 SEAT BELT PRE-TENSIONER LH	99
DTC Logic	73	DTC Logic	99
Diagnosis Procedure	73	Diagnosis Procedure	99
B1065, B1070 PASSENGER AIR BAG MOD- ULE	74	B1090, B1091, B1092, B1093, B1094, B1095 DIAGNOSIS SENSOR UNIT	101
DTC Logic	74	DTC Logic	101
Diagnosis Procedure	74	Diagnosis Procedure	101

B1106, B1107, B1108, B1109, B1110, B1111	B1137 SIDE AIR BAG MODULE LH	128	
DIAGNOSIS SENSOR UNIT	DTC Logic	128	A
DTC Logic	Diagnosis Procedure	128	
B1113, B1114 SATELLITE SENSOR RH	B1138, B1139, B1140, B1141, B1142, B1143		B
DIAGNOSIS SENSOR UNIT	DIAGNOSIS SENSOR UNIT	130	
DTC Logic	DTC Logic	130	C
Diagnosis Procedure	Diagnosis Procedure	130	
B1115 SATELLITE SENSOR RH	B1144 DIAGNOSIS SENSOR UNIT	131	D
DTC Logic	DTC Logic	131	
Diagnosis Procedure	Diagnosis Procedure	131	
B1116 SATELLITE SENSOR RH	B1145 CURTAIN AIR BAG MODULE RH	132	E
DTC Logic	DTC Logic	132	
Diagnosis Procedure	Diagnosis Procedure	132	
B1118, B1119 SATELLITE SENSOR LH	B1146 CURTAIN AIR BAG MODULE RH	134	F
DTC Logic	DTC Logic	134	
Diagnosis Procedure	Diagnosis Procedure	134	
B1120 SATELLITE SENSOR LH	B1147 CURTAIN AIR BAG MODULE RH	136	G
DTC Logic	DTC Logic	136	
Diagnosis Procedure	Diagnosis Procedure	136	
B1121 SATELLITE SENSOR LH	B1148 CURTAIN AIR BAG MODULE RH	138	SRC
DTC Logic	DTC Logic	138	
Diagnosis Procedure	Diagnosis Procedure	138	
B1122, B1123, B1124, B1125, B1126, B1127	B1150 CURTAIN AIR BAG MODULE LH	140	I
DIAGNOSIS SENSOR UNIT	DTC Logic	140	
DTC Logic	Diagnosis Procedure	140	J
Diagnosis Procedure	B1151 CURTAIN AIR BAG MODULE LH	142	
B1129 SIDE AIR BAG MODULE RH	DTC Logic	142	K
DTC Logic	Diagnosis Procedure	142	
Diagnosis Procedure	B1152 CURTAIN AIR BAG MODULE LH	144	L
B1130 SIDE AIR BAG MODULE RH	DTC Logic	144	
DTC Logic	Diagnosis Procedure	144	
Diagnosis Procedure	B1153 CURTAIN AIR BAG MODULE LH	146	M
B1131 SIDE AIR BAG MODULE RH	DTC Logic	146	
DTC Logic	Diagnosis Procedure	146	
Diagnosis Procedure	B1154, B1155, B1156, B1157, B1158, B1159		N
B1132 SIDE AIR BAG MODULE RH	DIAGNOSIS SENSOR UNIT	148	
DTC Logic	DTC Logic	148	
Diagnosis Procedure	Diagnosis Procedure	148	
B1134 SIDE AIR BAG MODULE LH	B1170, B1171, B1172, B1173, B1174, B1175		O
DTC Logic	DIAGNOSIS SENSOR UNIT	149	
Diagnosis Procedure	DTC Logic	149	
B1135 SIDE AIR BAG MODULE LH	Diagnosis Procedure	149	P
DTC Logic	B1186, B1187, B1188, B1189, B1190, B1191		
Diagnosis Procedure	DIAGNOSIS SENSOR UNIT	150	
B1136 SIDE AIR BAG MODULE LH	DTC Logic	150	
DTC Logic	Diagnosis Procedure	150	
Diagnosis Procedure	B1193 CURTAIN AIR BAG MODULE RH	151	
B1137 SIDE AIR BAG MODULE LH	DTC Logic	151	

Diagnosis Procedure	151	DTC Logic	175
B1194 CURTAIN AIR BAG MODULE RH	153	Diagnosis Procedure	175
DTC Logic	153	B1250, B1251, B1252, B1253, B1254, B1255	
Diagnosis Procedure	153	DIAGNOSIS SENSOR UNIT	176
B1195 CURTAIN AIR BAG MODULE RH	155	DTC Logic	176
DTC Logic	155	Diagnosis Procedure	176
Diagnosis Procedure	155	B1266, B1267, B1268, B1269 DIAGNOSIS	
B1196 CURTAIN AIR BAG MODULE RH	157	SENSOR UNIT	177
DTC Logic	157	DTC Logic	177
Diagnosis Procedure	157	Diagnosis Procedure	177
B1198 CURTAIN AIR BAG MODULE LH	159	B1282, B1283, B1284, B1285 DIAGNOSIS	
DTC Logic	159	SENSOR UNIT	178
Diagnosis Procedure	159	DTC Logic	178
B1199 CURTAIN AIR BAG MODULE LH	161	Diagnosis Procedure	178
DTC Logic	161	B1304 SATELLITE SEN RH	179
Diagnosis Procedure	161	DTC Logic	179
B1200 CURTAIN AIR BAG MODULE LH	163	Diagnosis Procedure	179
DTC Logic	163	B1306, B1308, B1309, B1310 SATELLITE	
Diagnosis Procedure	163	SEN RH	181
B1201 CURTAIN AIR BAG MODULE LH	165	DTC Logic	181
DTC Logic	165	Diagnosis Procedure	181
Diagnosis Procedure	165	B1307 SATELLITE SEN RH	183
B1202, B1203, B1204, B1205, B1206, B1207		DTC Logic	183
DIAGNOSIS SENSOR UNIT	167	Diagnosis Procedure	183
DTC Logic	167	B1311 SATELLITE SEN LH	184
Diagnosis Procedure	167	DTC Logic	184
B1209 FRONTAL COLLISION DETECTION .	168	Diagnosis Procedure	184
Description	168	B1313, B1315, B1316, B1317 SATELLITE	
DTC Logic	168	SEN LH	186
Diagnosis Procedure	168	DTC Logic	186
B1210 SIDE COLLISION DETECTION	169	Diagnosis Procedure	186
Description	169	B1314 SATELLITE SEN LH	188
DTC Logic	169	DTC Logic	188
Diagnosis Procedure	169	Diagnosis Procedure	188
B1212, B1213, B1214 SATELLITE SENSOR		B1336, B1337 SATELLITE SENSOR RH	189
RH	170	DTC Logic	189
DTC Logic	170	Diagnosis Procedure	189
Diagnosis Procedure	170	B1338, B1340, B1341, B1342 SATELLITE	
B1215, B1216, B1217 SATELLITE SENSOR		SENSOR RH	191
LH	172	DTC Logic	191
DTC Logic	172	Diagnosis Procedure	191
Diagnosis Procedure	172	B1339 SATELLITE SENSOR RH	193
B1218, B1219, B1220, B1221, B1222, B1223		DTC Logic	193
DIAGNOSIS SENSOR UNIT	174	Diagnosis Procedure	193
DTC Logic	174	B1343, B1344 SATELLITE SENSOR LH	194
Diagnosis Procedure	174	DTC Logic	194
B1234, B1235, B1236, B1237, B1238, B1239		Diagnosis Procedure	194
DIAGNOSIS SENSOR UNIT	175		

B1345, B1347, B1348, B1349 SATELLITE SENSOR LH	196	DTC Logic	196	DTC Logic	200	
DTC Logic	196	Diagnosis Procedure	196	Diagnosis Procedure	200	A
B1346 SATELLITE SENSOR LH	198			SYMPTOM DIAGNOSIS	201	
DTC Logic	198			SRS AIR BAG WARNING LAMP DOES NOT		B
Diagnosis Procedure	198			TURN OFF	201	
B1350, B1351 SATELLITE SENSOR	199			Diagnosis Procedure	201	C
DTC Logic	199			SRS AIR BAG WARNING LAMP DOES NOT		D
Diagnosis Procedure	199			TURN ON	202	
B1378, B1379, B1380, B1381 DIAGNOSIS SENSOR UNIT	200			Diagnosis Procedure	202	D
				SRS AIR BAG WARNING LAMP BLINKS	203	E
				Diagnosis Procedure	203	E
						F
						G
						SRC
						I
						J
						K
						L
						M
						N
						O
						P

PRECAUTIONS

< PRECAUTION >

PRECAUTION

PRECAUTIONS

Precautions for Removing Battery Terminal

INFOID:000000009980300

- When removing the 12V battery terminal, turn OFF the ignition switch and wait at least 30 seconds.

NOTE:

ECU may be active for several tens of seconds after the ignition switch is turned OFF. If the battery terminal is removed before ECU stops, then a DTC detection error or ECU data corruption may occur.

- For vehicles with the 2-batteries, be sure to connect the main battery and the sub battery before turning ON the ignition switch.

NOTE:

If the ignition switch is turned ON with any one of the terminals of main battery and sub battery disconnected, then DTC may be detected.

- After installing the 12V battery, always check "Self Diagnosis Result" of all ECUs and erase DTC.

NOTE:

The removal of 12V battery may cause a DTC detection error.

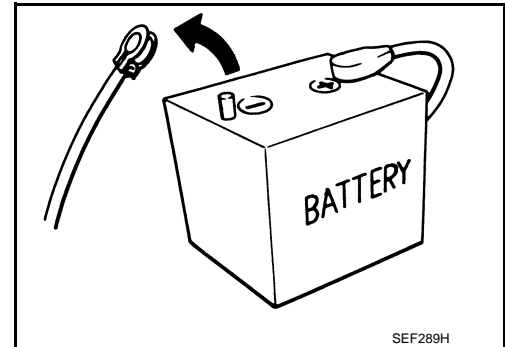

Precaution for Supplemental Restraint System (SRS) "AIR BAG" and "SEAT BELT PRE-TENSIONER"

INFOID:000000009649839

The Supplemental Restraint System such as "AIR BAG" and "SEAT BELT PRE-TENSIONER", used along with a front seat belt, helps to reduce the risk or severity of injury to the driver and front passenger for certain types of collision. This system includes seat belt switch inputs and dual stage front air bag modules. The SRS system uses the seat belt switches to determine the front air bag deployment, and may only deploy one front air bag, depending on the severity of a collision and whether the front occupants are belted or unbelted. Information necessary to service the system safely is included in the "SRS AIR BAG" and "SEAT BELT" of this Service Manual.

WARNING:

Always observe the following items for preventing accidental activation.

- To avoid rendering the SRS inoperative, which could increase the risk of personal injury or death in the event of a collision that would result in air bag inflation, all maintenance must be performed by an authorized NISSAN/INFINITI dealer.
- Improper maintenance, including incorrect removal and installation of the SRS, can lead to personal injury caused by unintentional activation of the system. For removal of Spiral Cable and Air Bag Module, see "SRS AIR BAG".
- Never use electrical test equipment on any circuit related to the SRS unless instructed to in this Service Manual. SRS wiring harnesses can be identified by yellow and/or orange harnesses or harness connectors.

PRECAUTIONS WHEN USING POWER TOOLS (AIR OR ELECTRIC) AND HAMMERS

WARNING:

Always observe the following items for preventing accidental activation.

- When working near the Air Bag Diagnosis Sensor Unit or other Air Bag System sensors with the ignition ON or engine running, never use air or electric power tools or strike near the sensor(s) with a hammer. Heavy vibration could activate the sensor(s) and deploy the air bag(s), possibly causing serious injury.
- When using air or electric power tools or hammers, always switch the ignition OFF, disconnect the battery, and wait at least 3 minutes before performing any service.

Service

INFOID:000000009649840

- Never use electrical test equipment to check SRS circuits unless instructed to in this Service Manual.
- Before servicing the SRS, turn ignition switch OFF, disconnect battery negative terminal and wait 3 minutes or more.

PRECAUTIONS

< PRECAUTION >

- For approximately 3 minutes after the cables are removed, it is still possible for the air bag and seat belt pretensioner to deploy. Therefore, never work on any SRS connectors or wires until at least 3 minutes have passed.
- Diagnosis sensor unit must always be installed with their arrow marks “←” pointing towards the front of the vehicle for proper operation. Also check diagnosis sensor unit for cracks, deformities or rust before installation and replace as required.
 - The spiral cable must be aligned with the neutral position since its rotations are limited. Never turn steering wheel and column after removal of steering gear.
 - Handle air bag module carefully. Always place driver and front passenger air bag modules with the pad side facing upward and seat mounted front side air bag module standing with the stud bolt side facing down.
 - Conduct self-diagnosis to check entire SRS for proper function after replacing any components.
 - After air bag inflates, the front instrument panel assembly should be replaced if damaged.
 - Always replace instrument panel pad following front passenger air bag deployment.
 - Never solder the harness when making repairs. Check that harness is not pinched and that there is no contact with other components.
 - Never allow harness to come in contact with oil, grease, waste oil, or water.
 - Never insert foreign materials, such as a screwdriver, into the harness connector. (This is to prevent accidental activation caused by static electricity.)
 - Always use CONSULT or SRS air bag warning lamp to perform the circuit diagnosis. (Never use an electric tester such as a circuit tester.)
 - Never enter in the deployment area of the pop-up roll bar. Never put an object in the deployment area of the pop-up roll bar. (This is to prevent injury in case of an unintentional deployment.)
 - When handling a pop-up roll bar, always grip the frame and handle carefully.
 - Never reuse a pop-up roll bar that has previously deployed.
 - Modification of the pop-up roll bar may cause unintentional deployment or a malfunction. Never disassemble or modify the pop-up roll bar.
 - Never allow the pop-up roll bar to be impacted (by dropping or otherwise). Always replace the pop-up roll bar if impacted.
 - When repairing the surrounding area of the pop-up roll bar, be careful not to apply excessive heat when welding or otherwise. Remove the pop-up roll bar in advance, if necessary. Be careful when modifying the mounting area or installing other parts because an incorrect procedure may cause damage or a malfunction.
 - Never disassemble the pop-up roll bar.
 - Never expose the pop-up roll bar to temperatures exceeding 90 °C (194 °F).
 - Never allow oil, grease, detergent, or water to come in contact with the pop-up roll bar.

A
B
C
D
E
F
G
I
J
K
L
M
N
O
P

SRC

COMPONENT PARTS

< SYSTEM DESCRIPTION >

SYSTEM DESCRIPTION

COMPONENT PARTS

Component Parts Location

INFOID:000000009649841

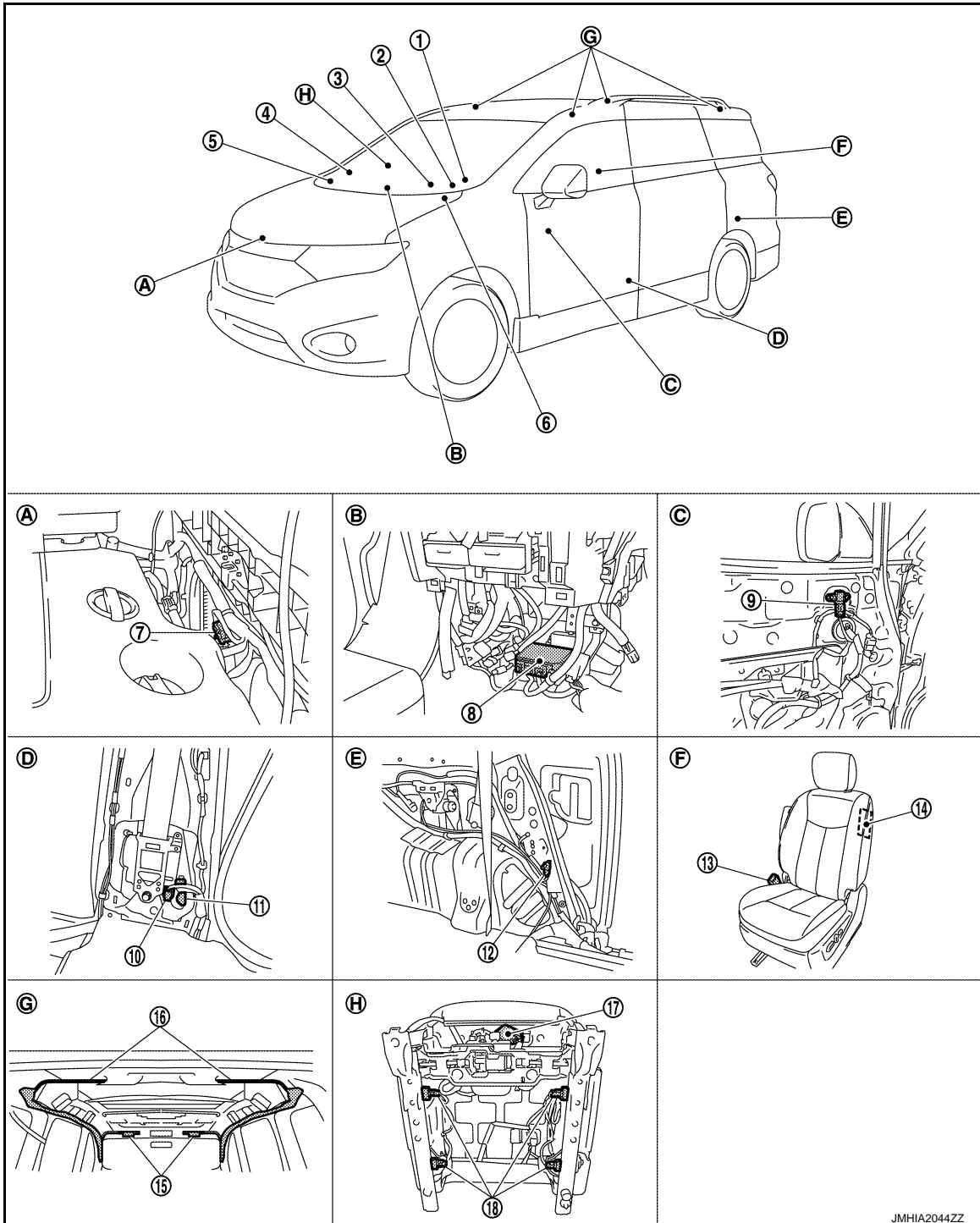

- | | | |
|--|--|--|
| A. Backside of radiator | B. View with instrument lower cover center removed | C. View with front door finisher removed |
| D. Behind center pillar lower garnish | E. View with luggage side finisher lower removed | F. Front seat LH |
| G. View with headlining assembly removed | H. Backside of passenger seat cushion frame | |

JMHIA2044ZZ

COMPONENT PARTS

< SYSTEM DESCRIPTION >

No.	Component	Function
1.	Driver air bag module	<ul style="list-style-type: none"> Receives signal from air bag diagnosis sensor unit and deploys air bag. In case of frontal collision where acceleration is more than the specified level, the ignition materials are ignited by electric ignition system. The system burns the gas generating materials resulting in a chemical reaction. This generates hot gases that flow into the air bag through a filter and expand the bag.
2.	Combination switch (spiral cable)	Supplies power supply to driver air bag module on steering wheel.
3.	Combination meter (air bag warning lamp)	Indicates air bag malfunctioning and deployment by blinking and illuminating air bag warning lamp.
4.	Passenger air bag OFF indicator	Indicates whether or not passenger air bag is in the activation mode based on the judgement of occupant detection system.
5.	Passenger air bag module	<ul style="list-style-type: none"> Receives signal from air bag diagnosis sensor unit and deploys air bag. In case of frontal collision where acceleration is more than the specified level, the ignition materials are ignited by electric ignition system. The system burns the gas generating materials resulting in a chemical reaction. This generates hot gases that flow into the air bag through a filter and expand the bag.
6.	BCM	Receive the collision detection signal when air bag diagnosis sensor unit detects collision. Refer to BCS-4, "BODY CONTROL SYSTEM : Component Parts Location" for detailed installation location.
7.	Crash zone sensor	<ul style="list-style-type: none"> Transmits signal to air bag diagnosis sensor unit when a frontal collision occurs. Crash zone sensor is a G sensor that outputs voltage signal during deceleration at the time of a vehicle frontal collision that is more than the specified limit is detected.
8.	Air bag diagnosis sensor unit	<ul style="list-style-type: none"> Detects a collision and supplies power supply for deployment to air bag module and pre-tensioner seat belt. It contains the "G" sensors for both frontal and side collisions and spare battery function in case of main battery damage in collision.
9.	Front door satellite sensor LH	<ul style="list-style-type: none"> Transmits signal to air bag diagnosis sensor unit when a side collision occurs. When air bag diagnosis sensor unit defines both signal voltage of the "G" sensor, pressure sensor and the safing algorithm to be that of collision which is more than the specified level, the driving circuit switches on and feeds the electric ignitor of both the side air bag, curtain air bag and pre-tensioner.
10.	Seat belt pre-tensioner LH	<ul style="list-style-type: none"> Receives signal from air bag diagnosis sensor unit and deploys seat belt pre-tensioner. In the case of a frontal collision or side collision or roll over that exceeds specified impact level, the air bag diagnosis sensor unit detects the deceleration caused by collision. It restrains the passenger with seat belt easing the stress on passengers chest with load limiter.
11.	Front satellite sensor LH	<ul style="list-style-type: none"> Transmits signal to air bag diagnosis sensor unit when a side collision occurs. When air bag diagnosis sensor unit defines both signal voltage of the "G" sensor, and the safing algorithm to be that of collision which is more than the specified level, the driving circuit switches on and feeds the electric ignitor of both the side air bag and curtain air bag and seat belt pre-tensioner.
12.	Rear satellite sensor LH	<ul style="list-style-type: none"> Transmits signal to air bag diagnosis sensor unit when a side collision occurs. When air bag diagnosis sensor unit defines both signal voltage of the "G" sensor, and the safing algorithm to be that of collision which is more than the specified level, the driving circuit switches on and feeds the electric ignitor of both the side air bag and curtain air bag and seat belt pre-tensioner.
13.	Seat belt buckle switch LH	Controls deployment timing depending on the seat belt condition that is fastened or unfastened.
14.	Side air bag module LH	<ul style="list-style-type: none"> Receives signal from air bag diagnosis sensor unit and deploys air bag. In case of side collision where acceleration is more than the specified level, the ignition materials are ignited by electric ignition system. The system burns the gas generating materials resulting in a chemical reaction. This generates hot gases that flow into the air bag through a filter and expand the bag.

A

B

C

D

E

F

G

SRC

I

J

K

L

M

N

O

P

COMPONENT PARTS

< SYSTEM DESCRIPTION >

No.	Component	Function
15.	Rear curtain air bag module	<ul style="list-style-type: none"> • Deploys according to collision judgment of G sensor, and safing sensor. • Receives collision signal from air bag diagnosis sensor unit, ignites, and burns ignition material by electric ignition system, when side collision exceeds setting limit of the vehicle. Gas is generated by chemical reaction of ignition material, passes filter, and deploys air bag. • Air bag module mainly consists of air bag and inflator that deploys air bag.
16.	Front curtain air bag module	<ul style="list-style-type: none"> • Deploys according to collision judgment of G sensor, and safing sensor. • Receives collision signal from air bag diagnosis sensor unit, ignites, and burns ignition material by electric ignition system, when side collision exceeds setting limit of the vehicle. Gas is generated by chemical reaction of ignition material, passes filter, and deploys air bag. • Air bag module mainly consists of air bag and inflator that deploys air bag.
17.	Occupant detection system control unit	Transmits the passenger seat status (occupied or empty) to air bag diagnosis sensor unit.
18.	Occupant detection system sensor	Transmits the passenger seat status (occupied or empty) to occupant detection system control unit. It is installed in the passenger seat cushion frame.

SYSTEM

< SYSTEM DESCRIPTION >

SYSTEM

System Description

INFOID:000000009649842

SYSTEM DIAGRAM

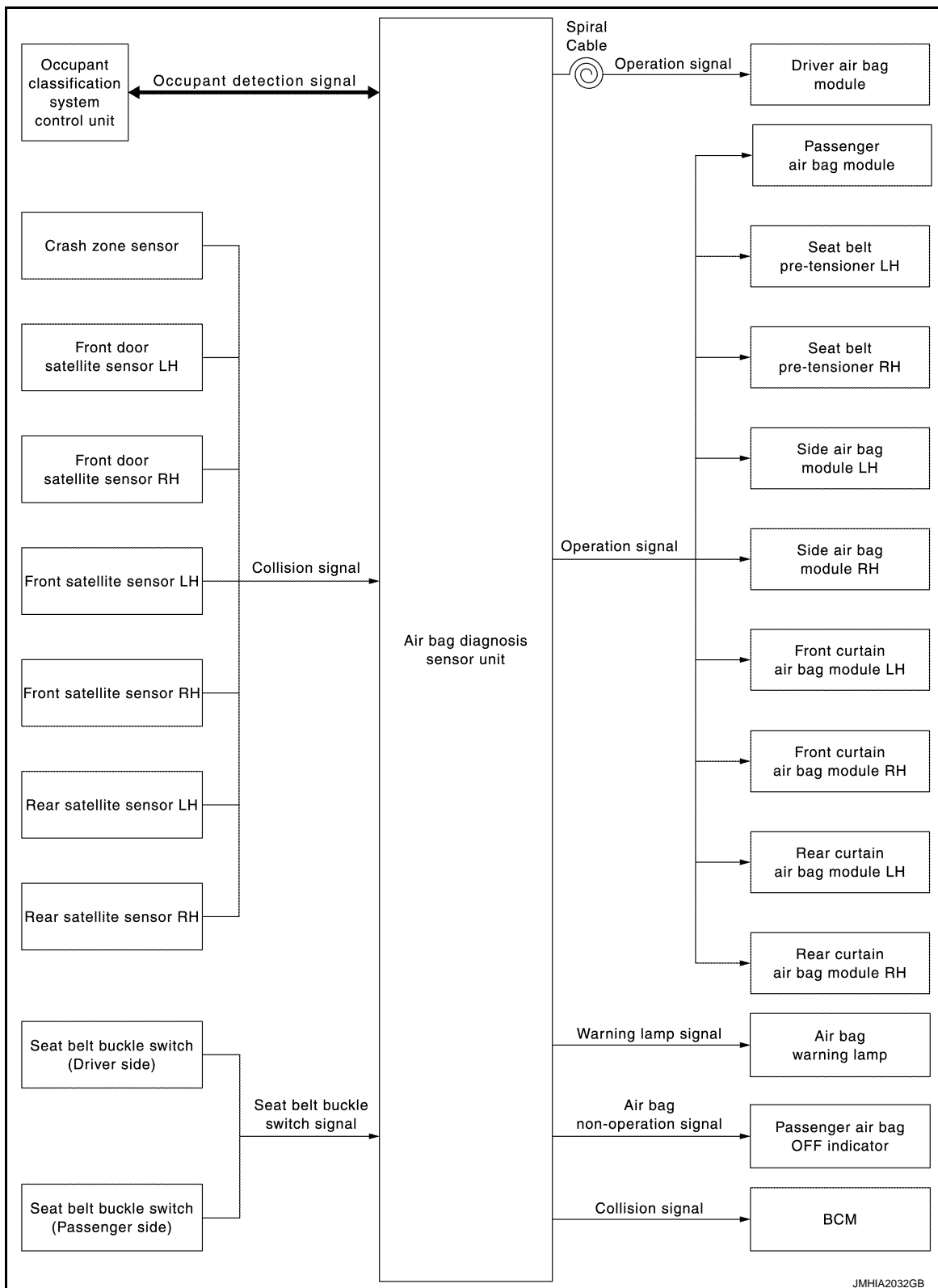

A
B
C
D
E
F
G
SRC
I
J
K
L
M
N
O
P

DESCRIPTION

Supplemental Restraint System (SRS) activates air bag module and seat belt pre-tensioner when it detects a frontal collision or a side collision that is more than the specified limit.

SYSTEM

< SYSTEM DESCRIPTION >

Together with other safety devices, it reduces the impact that occupant receives when vehicle collision occurs. Air bag diagnosis sensor unit supplies power supply to air bag module and pre-tensioner seat belt when deceleration that is more than the specified limit is detected by G sensor in air bag diagnosis sensor unit, crash zone sensor, satellite sensor, or front door satellite sensor.

Air bag module is composed of electric igniter (squib), filter, pyrotechnic material, and gas generating material. When air bag module receives a signal from air bag diagnosis sensor unit, air bag module ignites pyrotechnic material using electric igniter (squib) so that gas generating material generates high temperature nitrogen gas. The gas through filter activates air bag. At the same time, pre-tensioner seat belt receives power supply from air bag diagnosis sensor unit, gas generator is activated, and then gas is generated.

Balls in pipe are moved according to generated gas pressure and strike pinion gear on ELR shaft. ELR shaft rotates and retracts seat belt.

AIR BAG DIAGNOSIS SENSOR UNIT FUNCTIONS

Air bag diagnosis sensor unit has the following functions.

- Detects a collision and supplies the energy for deploying air bag and seat belt pre-tensioner.
- Detects and records electrical malfunction in air bag system and seat belt pre-tensioner system, and blinking air bag warning lamp.
- Detects and records the deployment of air bag and seat belt pre-tensioner, and turns ON air bag warning lamp.
- Indicates malfunctioning portion via the number of blinks from the air bag warning lamp in the diagnosis mode.
- Indicates the malfunction record via CONSULT.
- Suppresses the deployment of passenger air bag when passenger seat is empty or occupied by child or child-seat.
- When passenger seat is occupied by child or child seat, turns ON passenger air bag OFF indicator.
- When judges that passenger seat is occupied by a adult or a child and passenger seat belt is not fasten, turns ON seat belt warning lamp. Further information for the seat belt warning system.
- When collision is detected, collision signal is transmitted to BCM (collision detection function).

COLLISION MODES

The operation of SRS is different depending on the collision modes applications. SRS configurations that are activated for the following collision modes.

×: Apply —: Not apply

SRS configuration	Frontal collision	Left side collision	Right side collision
Driver air bag module	×	—	—
Passenger air bag module	×	—	—
Seat belt pre-tensioner LH	×	×	—
Seat belt pre-tensioner RH	×	—	×
Side air bag module LH	—	×	—
Side air bag module RH	—	—	×
Front curtain air bag module LH	—	×	—
Front curtain air bag module RH	—	—	×
Rear curtain air bag module LH	—	×	—
Rear curtain air bag module RH	—	—	×

OCCUPANT DETECTION SYSTEM

This Occupant Detection System has the following functions.

1. Suppress the deployment of front passenger air bag when front passenger seat is empty, or when occupied by child and child-seat. Turns ON front passenger air bag OFF indicator when front passenger seat is occupied by child-seat and child.
2. Indicates malfunction portion with blinking times of air bag warning lamp in diagnosis mode.
3. Indicates the malfunctioning record by CONSULT.
4. When “zero point reset” for occupant detection system is incomplete, CONSULT indicates that “zero point reset” is incomplete.
This function is applied to NISSAN genuine parts only.

NOTE:

SYSTEM

< SYSTEM DESCRIPTION >

- Operation of air bag diagnosis sensor unit when air bag diagnosis sensor unit receives information from Occupant Detection System.
- Even if zero point reset is “complete”, always perform zero point reset after the removal and installation of seat or the removal of control unit harness connector.

Status (front passenger seat)	Passenger air bag	Front passenger air bag OFF indicator	Air bag warning lamp	Seat belt warning lamp (when front passenger seat is unbuckled)
Empty	Suppress	OFF	OFF	OFF
An object	Suppress	ON	OFF	OFF
Child/ child-seat	Suppress	ON	OFF	ON
Adult	Enable to deploy	OFF	OFF	ON
Malfunction	Suppress	ON	Blinking	OFF
Zero point reset Not yet performed (NIS-SAN genuine parts only)	Suppress	ON	Blinking	OFF

A
B
C
D
E
F
G
I
J
K
L
M
N
O
P

SRC

DIAGNOSIS SYSTEM (AIR BAG)

< SYSTEM DESCRIPTION >

DIAGNOSIS SYSTEM (AIR BAG)

Description

INFOID:000000009649844

CAUTION:

- **Never use electrical test equipment on any circuit related to the SRS unless instructed in this Service Manual. SRS wiring harnesses can be identified by yellow and/or orange harnesses or harness connectors.**
- **Never repair, splice or modify the SRS wiring harness. If the harness is damaged, replace it with a new one.**
- **Keep ground portion clean.**

DIAGNOSIS FUNCTION

- The SRS self-diagnostic results can be read with air bag warning lamp and/or CONSULT.
- The user mode is exclusively prepared for the customer (driver). This mode warns the driver of a system malfunction through the operation of the air bag warning lamp.
- The diagnosis mode allows the technician to locate and inspect the malfunctioning part.
- The mode applications for the air bag warning lamp and CONSULT are as per the following items.

×: Application, —: Not application

Diagnosis tool	User mode	Diagnosis mode
Air bag warning lamp	×	×
CONSULT	—	×

On Board Diagnosis Function

INFOID:000000009649845

SRC

ON-BOARD DIAGNOSIS

There are two self diagnosis functions with air bag warning lamp per the following items.

- USER MODE
- DIAGNOSIS MODE

METHOD OF STARTING

- Diagnosis mode changes from user mode to diagnosis mode when changing operation is performed.
- In user mode, when SRS air bag warning lamp is not blinking, changing to diagnosis mode by ignition switch operation is not possible.
- In diagnosis mode, when repair is complete and system is normal, the mode changes to user mode when ignition switch is turned from OFF to ON.

Procedure to Change Diagnosis Mode

1. Turn ignition switch from OFF to ON.
2. SRS air bag lamp turns ON for 7 second and turns OFF, then turn ignition switch OFF within 1second after the lamp turns OFF.
3. After turning ignition switch OFF, wait for 3 seconds or more.
4. Repeat operation 1 to 3 for 2 times so that operation 1 to 3 is repeated for 3times in total.
5. Turn ignition switch from OFF to ON. Diagnosis mode changes.

USER MODE

In USER MODE, air bag warning lamp on combination meter blinks when a malfunction is detected and warns the customer (driver).



How to Read Air Bag Warning Lamp

1. Turn the ignition switch from OFF to ON, and check that the air bag warning lamp blinks.
2. Compare the air bag warning lamp blinking pattern with the examples.

Air Bag Warning Lamp Examples

DIAGNOSIS SYSTEM (AIR BAG)

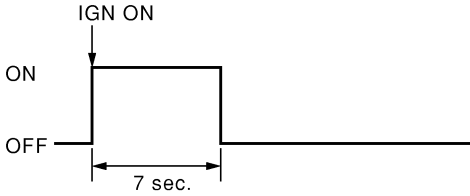
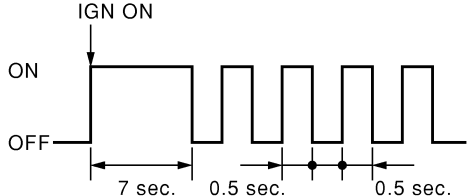
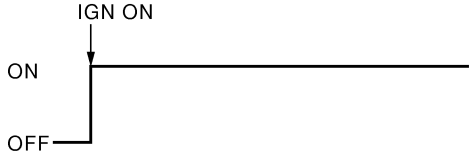
< SYSTEM DESCRIPTION >

Air bag warning lamp operation (user mode)	SRS condition	Reference item
 <p style="text-align: right;">SHIA0011E</p>	<ul style="list-style-type: none"> No malfunction is detected No further action is necessary 	<p style="text-align: center;">—</p>
 <p style="text-align: right;">SHIA0012E</p>	<ul style="list-style-type: none"> The system is malfunctioning Self diagnostic result is not erased after repair <p>Battery voltage is low (less than 9 V) or high battery voltage (more than 16V)</p> <p>Occupant detection function is disabled</p> <p>Zero point reset is incomplete</p> <p>Intermittent malfunction is detected in the past</p>	<p>Erase "Self Diagnostic Result" Refer to SRC-19, "CONSULT Function", How to Erase Self-diagnostic Result</p> <p>Check "CAUSE OF WARNING" in "Special Function" with CONSULT Refer to SRC-19, "CONSULT Function"</p> <p>Refer to SRC-203, "Diagnosis Procedure"</p> <p>Refer to SRC-41, "ZERO POINT RESET : Special Repair Requirement"</p> <p>Go to GI-42, "Intermittent Incident"</p>
 <p style="text-align: right;">SHIA0013E</p>	<ul style="list-style-type: none"> Air bag is deployed Seat belt pre-tensioner is deployed <ul style="list-style-type: none"> Air bag diagnosis sensor unit is malfunctioning Air bag power supply circuit is malfunctioning Air bag warning lamp circuit is malfunctioning 	<p>Go to SRC-168, "Diagnosis Procedure" or SRC-169, "Diagnosis Procedure"</p> <p>Go to SRC-201, "Diagnosis Procedure"</p>
 <p style="text-align: right;">SHIA0014E</p>	<ul style="list-style-type: none"> Air bag diagnosis sensor unit is malfunctioning Air bag warning lamp circuit is malfunctioning 	<p>Go to SRC-202, "Diagnosis Procedure"</p>

DIAGNOSIS MODE

The diagnosis mode can only be switched when a malfunction is detected in the user mode. Malfunctioning system is indicated according to blinking pattern of air bag warning lamp.

How to Read Air Bag Warning Lamp

- Follow the procedures of "PROCEDURE TO CHANGE DIAGNOSIS MODE", and switch to the diagnosis mode.

DIAGNOSIS SYSTEM (AIR BAG)

< SYSTEM DESCRIPTION >

2. Turn ignition switch ON. Check the blinking pattern of air bag warning lamp.
 There are 2 blinking patterns for the air bag warning lamp as per the following items.
 - Front air bag system: 3 second blink followed by a 0.5 second blink repeated.
 - Side air bag system: Two 1.5 second blinks followed by a 0.5 second blink repeated.

Front air bag system

Number of 0.5 second blinks	Malfunctioning items
0	<ul style="list-style-type: none"> • Self-diagnostic result is not erased after repair • Intermittent malfunction is detected in the past
1	Seat belt pre-tensioner RH
2	Driver air bag module
3	Seat belt pre-tensioner LH
5	Occupant detection system control unit
6	Crash zone sensor
7	Air bag diagnosis sensor unit
8	Passenger air bag module
11	Passenger air bag OFF indicator
17	Air bag diagnosis sensor unit

Side air bag system

Number of 0.5-second blinks	Malfunctioning items
1	Side air bag module RH
2	Side air bag module LH
3	Front satellite sensor RH
4	Front satellite sensor LH
5	Rear curtain air bag module RH
6	Rear curtain air bag module LH
7	Front curtain air bag module RH
8	Front curtain air bag module LH
9	Front door satellite sensor RH
10	Front door satellite sensor LH
11	Rear satellite sensor RH
12	Rear satellite sensor LH
20	Front door satellite sensor LH/RH

How to Erase Self-diagnostic Result

After a malfunction is repaired, turn the ignition switch OFF for one second or more, then turn ignition switch ON. The diagnosis mode returns to the user mode. At that time the self-diagnostic result is cleared.

EXAMPLE OF AIR BAG WARNING LAMP OPERATION IN THE DIAGNOSIS MODE

System Normal

When system is normal.

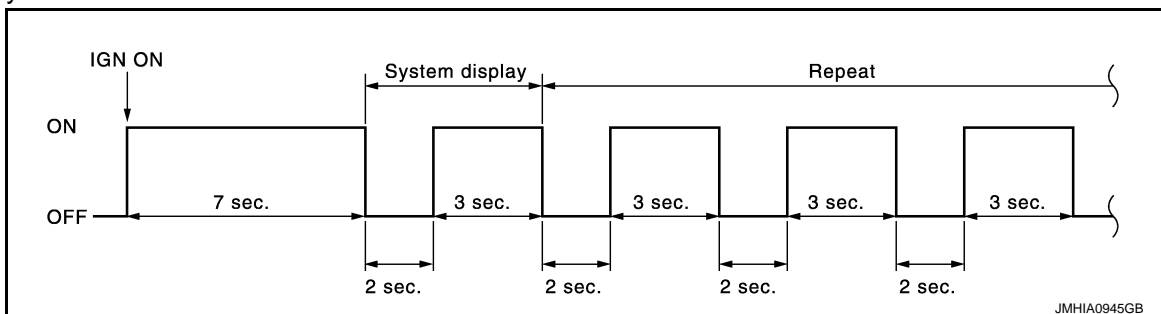

Single System Malfunction

- Front air bag system

DIAGNOSIS SYSTEM (AIR BAG)

< SYSTEM DESCRIPTION >

When air bag diagnosis sensor unit system (Item display 1) is malfunctioning.

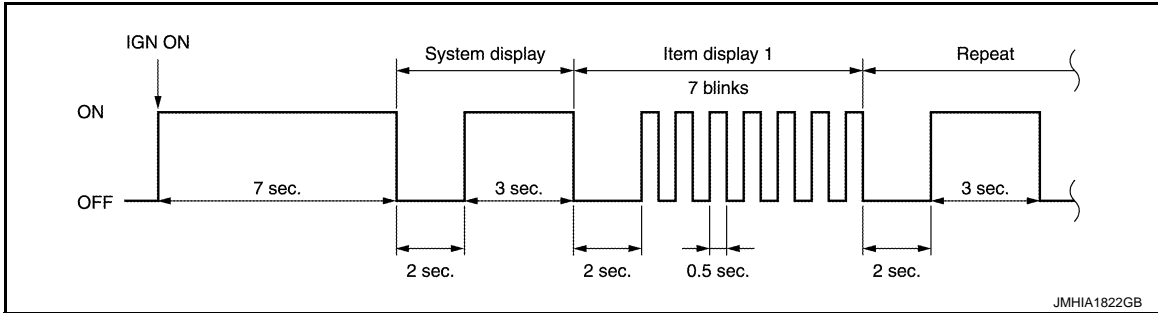

- Side air bag system

When rear curtain air bag module LH system (Item display 1) is malfunctioning.

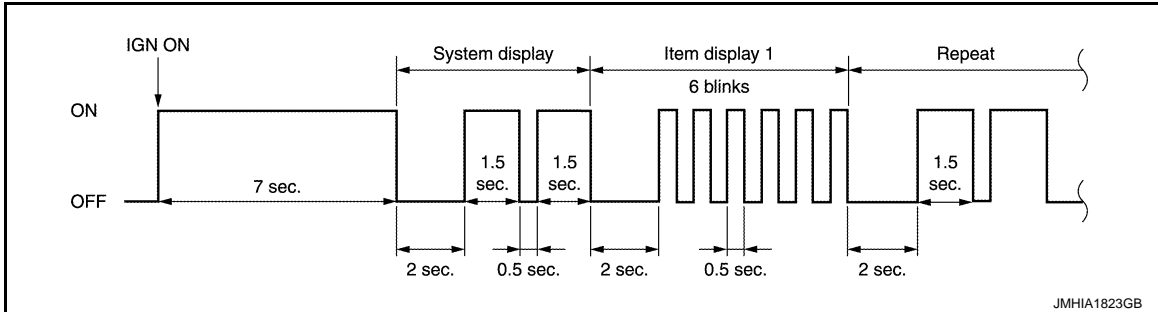

Multiple Systems Malfunction

- Front air bag system

When driver air bag module (Item display 1) and air bag diagnosis sensor unit system (Item display 2) are malfunctioning.

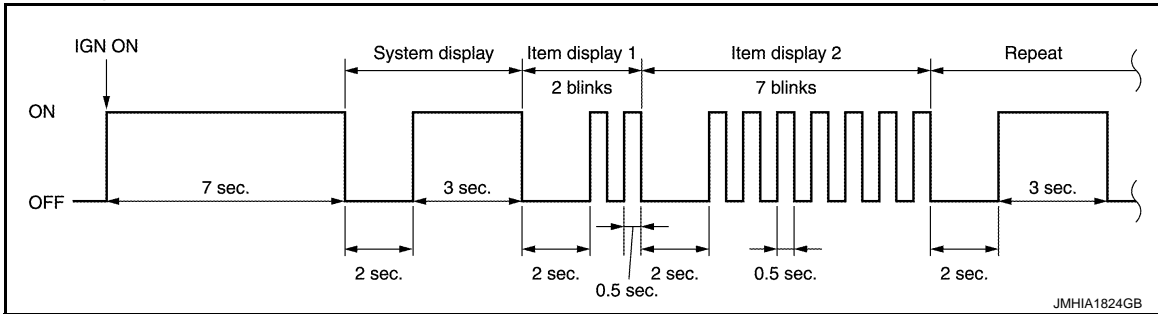

- Side air bag system

When front satellite sensor LH (Item display 1) and rear curtain air bag module LH system (Item display 2) are malfunctioning.

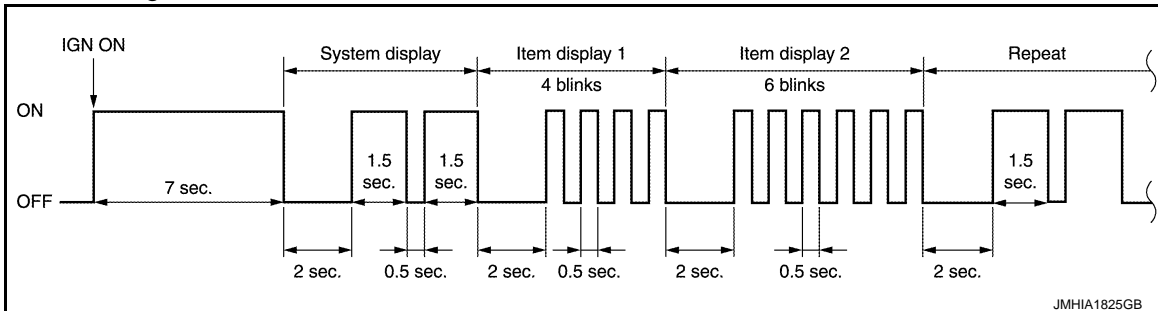

- Front air bag system and side air bag system

DIAGNOSIS SYSTEM (AIR BAG)

< SYSTEM DESCRIPTION >

When driver air bag module (Item display 1) and front satellite sensor RH (Item display2) are malfunctioning.

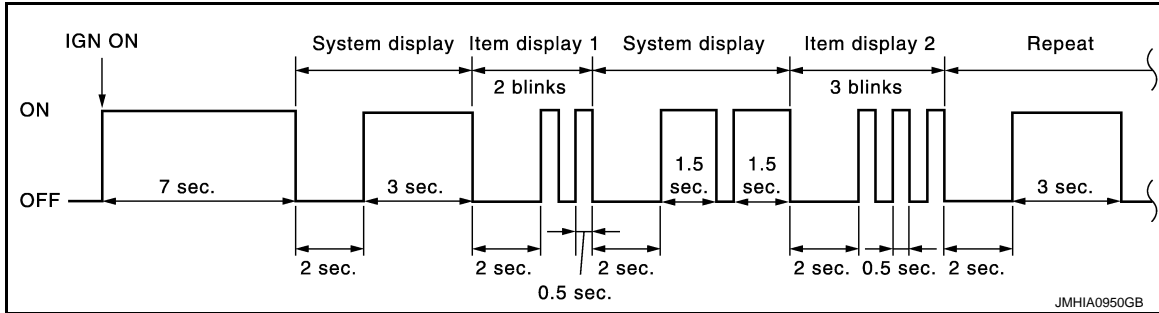

CONSULT Function

INFOID:000000009649846

APPLICATION ITEM

CONSULT performs the following functions.

Diagnosis mode	Description
Ecu Identification	Air bag diagnosis sensor unit ECU discriminated number (identification number) or part number is displayed. Air bag diagnosis sensor unit has individual ECU discriminated number (identification number) or part number based on model and equipment.
Self Diagnostic Result	The current self diagnosis results (also indicated with the number of air bag warning lamp blinks in the diagnosis mode) are displayed on CONSULT screen in real time. This refers to a malfunctioning part requiring repairs. Refer to SRC-22. "DTC Index" .
TROUBLE DIAG RECORD	With TROUBLE DIAG RECORD, diagnosis results previously erased by a reset operation can be displayed on CONSULT screen.
SELF-DIAG RESULT [CAN]	This item is displayed, but cannot be supported.
Cause of Warning Lamp	It displays the cause of warning lamp illumination that is not recorded in memory.

CAUSE OF WARNING LAMP

The SRS air bag warning lamp blinks when the ignition voltage is a voltage value (9V or less, or 16 V or more) at which the SRS air bag cannot operate normally. After blinking, if the ignition voltage returns to normal, SRS air bag warning lamp turns OFF. DTC memory is not performed while the abnormal ignition voltage is detected. The mode cannot be switched to trouble diagnosis mode when the ignition switch is operated. "No DTC" is displayed when checking "Self-diagnosis result" using CONSULT.

NOTE:

- SRS air bag warning may blink when the condition is out of detection area* of the satellite sensor in door. The system is normal if SRS air bag warning lamp turns OFF after the condition returns within detection area of the satellite sensor in door.
- SRS air bag warning lamp blinks when the zero point reset is incomplete after replacing the occupant detection system control unit. (SRS air bag warning lamp turns OFF after the zero point reset is complete.)
- *: Pressure inside of door is excessively low and air bag system cannot be operated normally (example: altitude is approximately 4,000 m or more).

DIAGNOSIS SYSTEM (AIR BAG)

< SYSTEM DESCRIPTION >

Display item	Display content	Actions by worker
IGN VOLT COND	<p>The ignition voltage recognized by air bag system (air bag control unit and occupant detection system control unit) is displayed or a message stating that condition is out of detection range of satellite sensor in door is displayed.</p> <ul style="list-style-type: none"> • OK: Normal • LOW: The ignition voltage is low, high, or out of detection range of satellite sensor in door 	<p>Perform the check at an altitude of 4,000 m or less.</p> <ul style="list-style-type: none"> • Check battery voltage if the ignition voltage status is displayed as "LOW". • Check battery voltage if the ignition voltage status is "OK" and the number of times detected is 1 or more. This is because an ignition voltage error may be detected in the past. <p>NOTE: If battery voltage is normal, the cause may be that out of detection range of satellite sensor in door is detected.</p>
IGN VOLT TIME	<p>Total number of times is displayed, summing up the number of times ignition voltage error is detected and the number of times that out of detection range of satellite sensor in door is detected. (Detection record is erased and counter returns to "0" by "ERASE MEMORY" in "Self-diagnosis results" using CONSULT.)</p>	
LOW V RECORDED	<p>Number of times ignition switch ON is displayed after ignition voltage error or out of detection range of satellite sensor in door is detected. (Detection record is erased and counter returns to "0" by "ERASE MEMORY" in "Self-diagnosis results" using CONSULT.)</p>	

DIAGNOSIS SYSTEM (OCCUPANT DETECTION SYSTEM)

< SYSTEM DESCRIPTION >

DIAGNOSIS SYSTEM (OCCUPANT DETECTION SYSTEM)

CONSULT Function

INFOID:000000009649847

ZERO POINT RESET DESCRIPTION

This vehicle adopts occupant detection system with a weight detecting method. When replacing, or removing and installing passenger seat, always perform "zero point reset" so that the vehicle recognizes zero point. If zero point reset is incomplete, occupant detection seat sensor does not operate normally.

WORK SUPPORT

Monitor item	Description
Zero point reset function	Perform zero point reset. Refer to SRC-41, "ZERO POINT RESET : Special Repair Requirement" .

A
B
C
D
E
F
G
I
J
K
L
M
N
O
P

SRC

DIAGNOSIS SENSOR UNIT

< ECU DIAGNOSIS INFORMATION >

ECU DIAGNOSIS INFORMATION

DIAGNOSIS SENSOR UNIT

DTC Index

INFOID:000000009649848

DTC	Diagnostic item	Explanation	Reference page
—	NO DTC IS DETECTED.	Low battery voltage (Less than 9 V) or High battery voltage (more than 16 V)	SRC-19, "CONSULT Function" .
		Occupant detection function is disabled	SRC-19, "CONSULT Function" .
		Zero point reset is incomplete	SRC-21, "CONSULT Function"
		Self-diagnostic result is not erased after repair	SRC-15, "On Board Diagnosis Function" , SRC-19, "CONSULT Function" .
		Intermittent malfunction is detected in the past	GI-42, "Intermittent Incident"
	No malfunction is detected	—	
B1001-B1005	CONTROL UNIT	Air bag diagnosis sensor unit is malfunctioning	SRC-43, "DTC Logic" .
B1006-B1010	CONTROL UNIT	Air bag diagnosis sensor unit is malfunctioning	SRC-44, "DTC Logic" .
B1011-B1015	CONTROL UNIT	Air bag diagnosis sensor unit is malfunctioning	SRC-45, "DTC Logic" .
B1017 B1020 B1021	OCCUPANT SENS C/U [UNIT FAIL]	Malfunction occurs in occupant detection system control unit	SRC-46, "DTC Logic"
B1018	OCCUPANT SENS [UNIT FAIL]	Malfunction occurs in occupant detection system sensor	SRC-48, "DTC Logic"
B1022	OCCUPANT SENS C/U [COMM FAIL]	Malfunction occurs in occupant detection system control unit, circuit of occupant detection system control unit, or air bag diagnosis sensor unit	SRC-50, "DTC Logic"
B1023	PASS A/B INDCTR CKT [UNIT FAIL]	Passenger air bag OFF indicator circuit is open or shorted to ground or the circuits are shorted each other	SRC-52, "DTC Logic"
B1025 B1032 B1048	OCS SENSOR	Malfunction occurs in occupant detection system control unit, circuit of occupant detection system control unit, or air bag diagnosis sensor unit	SRC-54, "DTC Logic"
B1026-B1031	CONTROL UNIT	Air bag diagnosis sensor unit is malfunctioning	SRC-56, "DTC Logic" .
B1033 B1034	CRASH ZONE SEN [UNIT FAIL]	Crash zone sensor is malfunctioning	SRC-57, "DTC Logic" .
B1035	CRASH ZONE SEN [COMM FAIL]	Crash zone sensor is malfunctioning	SRC-59, "DTC Logic" .
B1036	CRASH ZONE SEN [UNMATCH]	Crash zone sensor is out of the specified specification	SRC-61, "DTC Logic" .
B1037 B1039 B1041	CRASH ZONE SENS1	Crash zone sensor is malfunctioning	SRC-62, "DTC Logic" .
B1042-B1047	CONTROL UNIT	Air bag diagnosis sensor unit is malfunctioning	SRC-64, "DTC Logic" .
B1049 B1054	DRIVER AIRBAG MODULE [OPEN]	Driver air bag module circuit is open (including the spiral cable)	SRC-65, "DTC Logic" .

DIAGNOSIS SENSOR UNIT

< ECU DIAGNOSIS INFORMATION >

DTC	Diagnostic item	Explanation	Reference page
B1050 B1055	DRIVER AIRBAG MODULE [VB-SHORT]	Driver air bag module circuit is shorted to power supply circuit (including the spiral cable)	SRC-67, "DTC Logic" .
B1051 B1056	DRIVER AIRBAG MODULE [GND-SHORT]	Driver air bag module circuit is shorted to ground (including the spiral cable)	SRC-69, "DTC Logic" .
B1052 B1057	DRIVER AIRBAG MODULE [SHORT]	Driver air bag module circuits are shorted to each other (including spiral cable)	SRC-71, "DTC Logic" .
B1058-B1063	CONTROL UNIT	Air bag diagnosis sensor unit is malfunctioning	SRC-73, "DTC Logic" .
B1065 B1070	ASSIST A/B MODULE [OPEN]	Passenger air bag module circuit is open	SRC-74, "DTC Logic" .
B1066 B1071	ASSIST A/B MODULE [VB-SHORT]	Passenger air bag module circuit is shorted to power supply circuit	SRC-76, "DTC Logic" .
B1067 B1072	ASSIST A/B MODULE [GND-SHORT]	Passenger air bag module circuit is shorted to ground	SRC-78, "DTC Logic" .
B1068 B1073	ASSIST A/B MODULE [SHORT]	Passenger air bag module circuits are shorted to each other	SRC-80, "DTC Logic" .
B1074-B1079	CONTROL UNIT	Air bag diagnosis sensor unit is malfunctioning	SRC-82, "DTC Logic" .
B1080 B1096	DRIVER AIRBAG MODULE [SHORT]	Driver air bag module circuits are shorted to each other (including spiral cable)	SRC-83, "DTC Logic" .
B1081	PRE-TEN FRONT RH [OPEN]	Seat belt pre-tensioner RH circuit is open	SRC-85, "DTC Logic" .
B1082	PRE-TEN FRONT RH [VB-SHORT]	Seat belt pre-tensioner RH circuit is shorted to power supply circuit	SRC-87, "DTC Logic" .
B1083	PRE-TEN FRONT RH [GND-SHORT]	Seat belt pre-tensioner RH circuit is shorted to ground	SRC-89, "DTC Logic" .
B1084	PRE-TEN FRONT RH [SHORT]	Seat belt pre-tensioner RH circuits are shorted to each other	SRC-91, "DTC Logic" .
B1086	PRE-TEN FRONT LH [OPEN]	Seat belt pre-tensioner LH circuit is open	SRC-93, "DTC Logic" .
B1087	PRE-TEN FRONT LH [VB-SHORT]	Seat belt pre-tensioner LH circuit is shorted to power supply circuit	SRC-95, "DTC Logic" .
B1088	PRE-TEN FRONT LH [GND-SHORT]	Seat belt pre-tensioner LH circuit is shorted to ground	SRC-97, "DTC Logic" .
B1089	PRE-TEN FRONT LH [SHORT]	Seat belt pre-tensioner LH circuits are shorted to each other	SRC-99, "DTC Logic" .
B1090-B1095	CONTROL UNIT	Air bag diagnosis sensor unit is malfunctioning	SRC-101, "DTC Logic" .
B1106-B1111	CONTROL UNIT	Air bag diagnosis sensor unit is malfunctioning	SRC-102, "DTC Logic" .
B1113 B1114	SATELLITE SENS RH [UNIT FAIL]	Front satellite sensor RH is malfunctioning	SRC-103, "DTC Logic" .
B1115	SATELLITE SENS RH [COMM FAIL]	Front satellite sensor RH is malfunctioning	SRC-105, "DTC Logic" .
B1116	SATELLITE SENS RH [UNMATCH]	Front satellite sensor RH is out of the specified specification	SRC-107, "DTC Logic" .
B1118 B1119	SATELLITE SENS LH [UNIT FAIL]	Front satellite sensor LH is malfunctioning	SRC-108, "DTC Logic" .
B1120	SATELLITE SENS LH [COMM FAIL]	Front satellite sensor LH is malfunctioning	SRC-110, "DTC Logic" .
B1121	SATELLITE SENS LH [UNMATCH]	Front satellite sensor LH is out of the specified specification	SRC-112, "DTC Logic" .

A
B
C
D
E
F
G
I
J
K
L
M
N
O
P

SRC

DIAGNOSIS SENSOR UNIT

< ECU DIAGNOSIS INFORMATION >

DTC	Diagnostic item	Explanation	Reference page
B1122-B1127	CONTROL UNIT	Air bag diagnosis sensor unit is malfunctioning	SRC-113, "DTC Logic" .
B1129	SIDE MODULE RH [OPEN]	Side air bag module RH circuit is open	SRC-114, "DTC Logic" .
B1130	SIDE MODULE RH [VB-SHORT]	Side air bag module RH circuit is shorted to power supply circuit	SRC-116, "DTC Logic" .
B1131	SIDE MODULE RH [GND-SHORT]	Side air bag module RH circuit is shorted to ground	SRC-118, "DTC Logic" .
B1132	SIDE MODULE RH [SHORT]	Side air bag module RH circuits are shorted to each other	SRC-120, "DTC Logic" .
B1134	SIDE MODULE LH [OPEN]	Side air bag module LH circuit is open	SRC-122, "DTC Logic" .
B1135	SIDE MODULE LH [VB-SHORT]	Side air bag module LH circuit is shorted to power supply circuit	SRC-124, "DTC Logic" .
B1136	SIDE MODULE LH [GND-SHORT]	Side air bag module LH circuit is shorted to ground	SRC-126, "DTC Logic" .
B1137	SIDE MODULE LH [SHORT]	Side air bag module LH circuits are shorted to each other	SRC-128, "DTC Logic" .
B1138-B1143	CONTROL UNIT	Air bag diagnosis sensor unit is malfunctioning	SRC-130, "DTC Logic" .
B1144	CONTROL UNIT [MISS INSTALLATION]	Air bag diagnosis sensor unit is malfunctioning or out of the specified specification	SRC-131, "DTC Logic" .
B1145	CURTAIN MODULE RH [OPEN]	Rear curtain air bag module RH circuit is open	SRC-132, "DTC Logic" .
B1146	CURTAIN MODULE RH [VB-SHORT]	Rear curtain air bag module RH circuit is shorted to power supply circuit	SRC-134, "DTC Logic" .
B1147	CURTAIN MODULE RH [GND-SHORT]	Rear curtain air bag module RH circuit is shorted to ground	SRC-136, "DTC Logic" .
B1148	CURTAIN MODULE RH [SHORT]	Rear curtain air bag module RH circuits are shorted to each other	SRC-138, "DTC Logic" .
B1150	CURTAIN MODULE LH [OPEN]	Rear curtain air bag module LH circuit is open	SRC-140, "DTC Logic" .
B1151	CURTAIN MODULE LH [VB-SHORT]	Rear curtain air bag module LH circuit is shorted to power supply circuit	SRC-142, "DTC Logic" .
B1152	CURTAIN MODULE LH [GND-SHORT]	Rear curtain air bag module LH circuit is shorted to ground	SRC-144, "DTC Logic" .
B1153	CURTAIN MODULE LH [SHORT]	Rear curtain air bag module LH circuits are shorted to each other	SRC-146, "DTC Logic" .
B1154-B1159	CONTROL UNIT	Air bag diagnosis sensor unit is malfunctioning	SRC-148, "DTC Logic" .
B1170-B1175	CONTROL UNIT	Air bag diagnosis sensor unit is malfunctioning	SRC-149, "DTC Logic" .
B1186-B1191	CONTROL UNIT	Air bag diagnosis sensor unit is malfunctioning	SRC-150, "DTC Logic" .
B1193	CURTAIN MODULE RH [OPEN]	Front curtain air bag module RH circuit is open	SRC-151, "DTC Logic" .
B1194	CURTAIN MODULE RH [VB-SHORT]	Front curtain air bag module RH circuit is shorted to power supply circuit	SRC-153, "DTC Logic" .
B1195	CURTAIN MODULE RH [GND-SHORT]	Front curtain air bag module RH circuit is shorted to ground	SRC-155, "DTC Logic" .
B1196	CURTAIN MODULE RH [SHORT]	Front curtain air bag module RH circuits are shorted to each other	SRC-157, "DTC Logic" .

DIAGNOSIS SENSOR UNIT

< ECU DIAGNOSIS INFORMATION >

DTC	Diagnostic item	Explanation	Reference page
B1198	CURTAIN MODULE LH [OPEN]	Front curtain air bag module LH circuit is open	SRC-159, "DTC Logic"
B1199	CURTAIN MODULE LH [VB-SHORT]	Front curtain air bag module LH circuit is shorted to power supply circuit	SRC-161, "DTC Logic"
B1200	CURTAIN MODULE LH [GND-SHORT]	Front curtain air bag module LH circuit is shorted to ground	SRC-163, "DTC Logic"
B1201	CURTAIN MODULE LH [SHORT]	Front curtain air bag module LH circuits are shorted to each other	SRC-165, "DTC Logic"
B1202-B1207	CONTROL UNIT	Air bag diagnosis sensor unit is malfunctioning	SRC-167, "DTC Logic"
B1209	FRONTAL COLLISION DETECTION	Seat belt pre-tensioner, driver air bag and passenger air bag are deployed	SRC-168, "Description"
B1210	SIDE COLLISION DETECTION	Side air bag, curtain air bag and seat belt pre-tensioner are deployed	SRC-169, "DTC Logic"
B1212-B1214	RH1 SAT-SENS	Front satellite sensor RH is malfunctioning	SRC-170, "DTC Logic"
B1215-B1217	LH1 SAT-SENS	Front satellite sensor LH is malfunctioning	SRC-172, "DTC Logic"
B1218-B1223	CONTROL UNIT	Air bag diagnosis sensor unit is malfunctioning	SRC-174, "DTC Logic"
B1234-B1239	CONTROL UNIT	Air bag diagnosis sensor unit is malfunctioning	SRC-175, "DTC Logic"
B1250-B1255	CONTROL UNIT	Air bag diagnosis sensor unit is malfunctioning	SRC-176, "DTC Logic"
B1266-B1269	CONTROL UNIT	Air bag diagnosis sensor unit is malfunctioning	SRC-177, "DTC Logic"
B1282-B1285	CONTROL UNIT	Air bag diagnosis sensor unit is malfunctioning	SRC-178, "DTC Logic"
B1304	SATELLITE SENS RH [UNIT MALF]	Rear satellite sensor RH is malfunctioning	SRC-179, "DTC Logic"
B1306 B1308 B1309 B1310	SATELLITE SENS RH [COMM MALF]	Rear satellite sensor RH is malfunctioning	SRC-181, "DTC Logic"
B1307	SATELLITE SENS RH [UNMATCH]	Rear satellite sensor RH is out of the specified specification	SRC-183, "DTC Logic"
B1311	SATELLITE SENS LH [UNIT MALF]	Rear satellite sensor LH is malfunctioning	SRC-184, "DTC Logic"
B1313 B1315 B1316 B1317	SATELLITE SENS LH [COMM MALF]	Rear satellite sensor LH is malfunctioning	SRC-186, "DTC Logic"
B1314	SATELLITE SENS LH [UNMATCH]	Rear satellite sensor LH is out of the specified specification	SRC-188, "DTC Logic"
B1336 B1337	FR-RH DOOR SATEL SENS [SENSOR MALFUNCTION]	Front door satellite sensor RH is malfunctioning	SRC-189, "DTC Logic"
B1338 B1340 B1341 B1342	FR-RH DOOR SATEL SENS [COMM MALFUNCTION]	Front door satellite sensor RH is malfunctioning	SRC-191, "DTC Logic"
B1339	FR-RH DOOR SATEL SENS [MIS-INSTALLATION]	Front door satellite sensor RH is out of the specified specification	SRC-193, "DTC Logic"
B1343 B1344	FR-LH DOOR SATEL SENS [SENSOR MALFUNCTION]	Front door satellite sensor LH is malfunctioning	SRC-194, "DTC Logic"

A
B
C
D
E
F
G
I
J
K
L
M
N
O
P

SRC

DIAGNOSIS SENSOR UNIT

< ECU DIAGNOSIS INFORMATION >

DTC	Diagnostic item	Explanation	Reference page
B1345 B1347 B1348 B1349	FR-LH DOOR SATEL SENS [COMM MALFUNCTION]	Front door satellite sensor LH is malfunctioning	SRC-196, "DTC Logic"
B1346	FR-LH DOOR SATEL SENS [MIS-INSTALLATION]	Front door satellite sensor LH is out of the specified specification	SRC-198, "DTC Logic"
B1350 B1351	FR DOOR SATEL SENS	Front door satellite sensor is malfunctioning	SRC-199, "DTC Logic"
B1378-B1381	CONTROL UNIT	Air bag diagnosis sensor unit is malfunctioning	SRC-200, "DTC Logic"

SRS AIR BAG SYSTEM

< WIRING DIAGRAM >

WIRING DIAGRAM

SRS AIR BAG SYSTEM

Wiring Diagram

INFOID:000000009649849

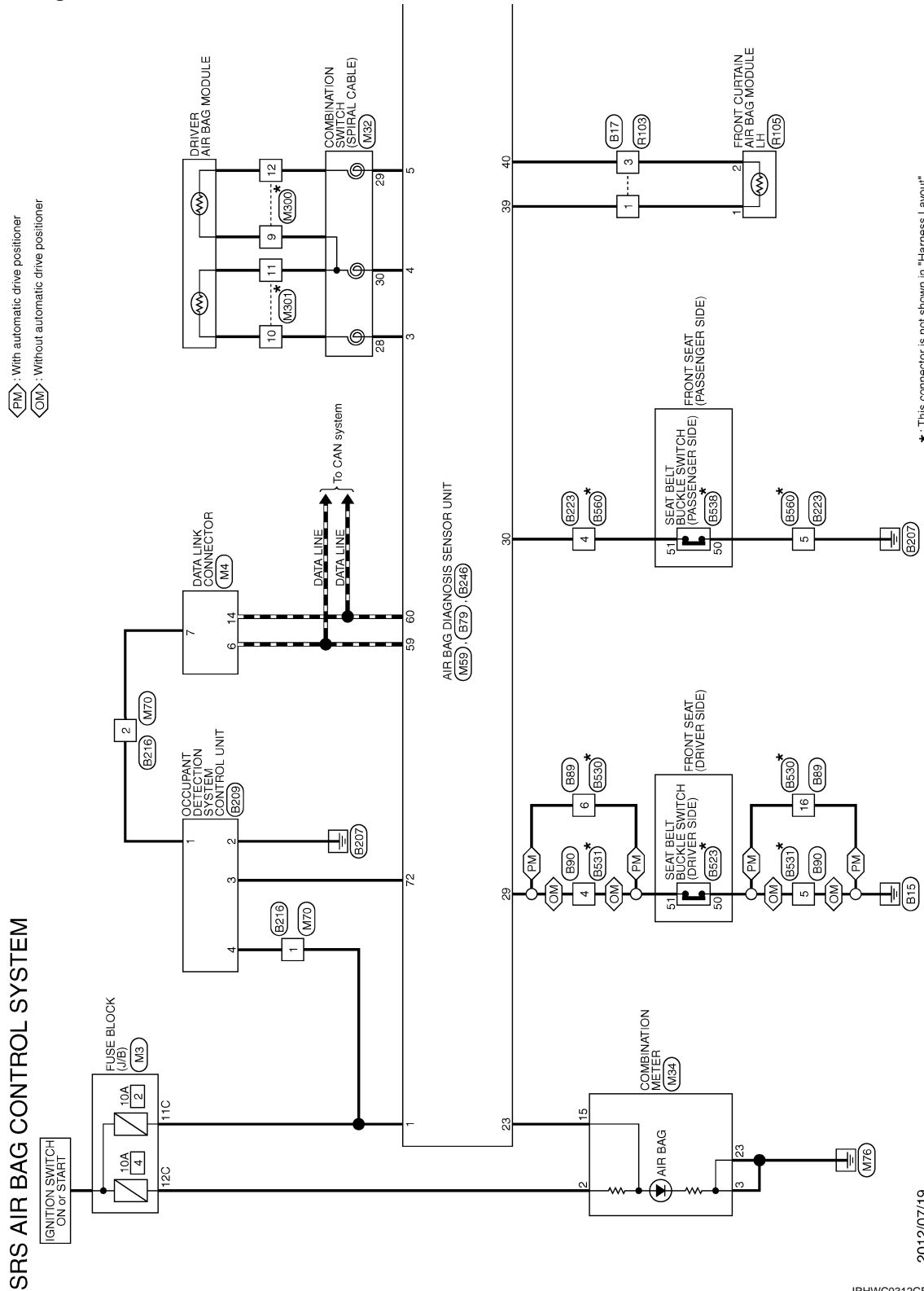

2012/07/19

JRHWC0312GB

A
B
C
D
E
F
G
H
I
J
K
L
M
N
O
P

SRC

SRS AIR BAG SYSTEM

< WIRING DIAGRAM >

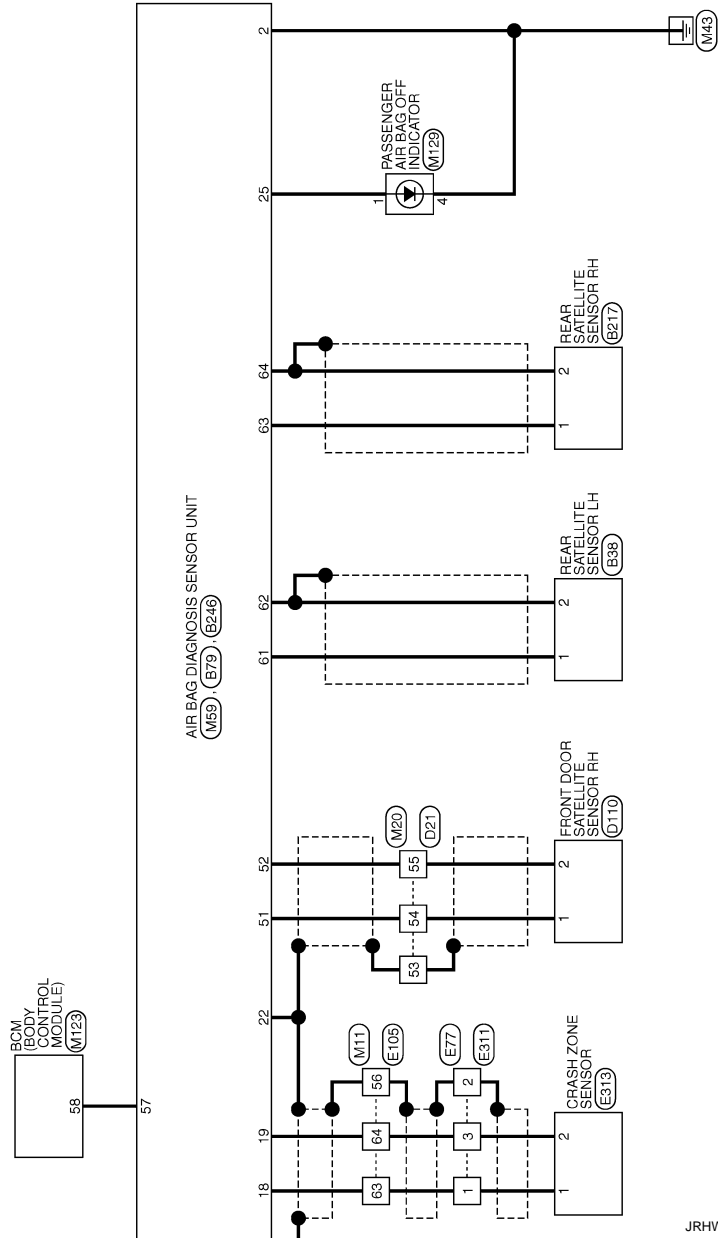

JRHWC0314GB

A
B
C
D
E
F
G
H
I
J
K
L
M
N
O
P

SRC

SRS AIR BAG SYSTEM

< WIRING DIAGRAM >

SRS AIR BAG CONTROL SYSTEM

Connector No.	B14
Connector Name	WIRE TO WIRE
Connector Type	TK04EY



Connector No.	B17
Connector Name	WIRE TO WIRE
Connector Type	TK06MG-Y-BD



Connector No.	B37
Connector Name	FRONT SATELLITE SENSOR LH
Connector Type	HK02FY-IV-EX



Connector No.	B72
Connector Name	REAR CURTAIN AIR BAG MODULE LH
Connector Type	ACB02EOR



Terminal No.	Color Of Wire	Signal Name [Specification]
1	G	--
2	R	--
3	G	--
4	R	--

Connector No.	B16
Connector Name	SIDE AIR BAG MODULE LH
Connector Type	TK02FY-EX-IV



Terminal No.	Color Of Wire	Signal Name [Specification]
1	LG	--
2	G	--
3	V	--
4	V	--
6	G	--

Connector No.	B36
Connector Name	SEAT BELT PRE-TENSIONER LH
Connector Type	ACB00FY



Terminal No.	Color Of Wire	Signal Name [Specification]
1	W/L	--
2	L/G	--

Connector No.	B38
Connector Name	REAR SATELLITE SENSOR LH
Connector Type	HK02FY-IV-EX



Terminal No.	Color Of Wire	Signal Name [Specification]
1	P	--
2	BR	--

Connector No.	B79
Connector Name	AIR BAG DIAGNOSIS SENSOR UNIT
Connector Type	NR2ZF-Y-IV-EX

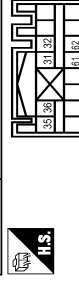

Terminal No.	Color Of Wire	Signal Name [Specification]
1	V	--
2	SB	--

Terminal No.	Color Of Wire	Signal Name [Specification]
1	P	--
2	LG	--

Terminal No.	Color Of Wire	Signal Name [Specification]
1	W	--
2	B	--

Terminal No.	Color Of Wire	Signal Name [Specification]
10	P	PLH(-)
11	LG	PLH(-)
29	GR	LH BUCKLE SW INPUT
31	V	SLH(-)
32	SB	SLH(-)
35	Y	RR CLH(+)
36	BR	RR CLH(-)
39	LG	FR CLH(-)
40	V	FR CLH(-)
47	W/L	SATELLITE LH(+)
48	W/L	SATELLITE LH(-)
55	SHIELD	SATELLITE LH(+)
61	W	RR SATELLITE SENS LH+
62	B	RR SATELLITE SENS LH-

JRHWC0964GB

SRS AIR BAG SYSTEM

< WIRING DIAGRAM >

SRS AIR BAG CONTROL SYSTEM

Connector No.	B215
Connector Name	WIRE TO WIRE
Connector Type	NS506FW-CS



Terminal No.	Color Of Wire	Signal Name [Specification]
1	P	-
2	BR	-
3	SB	-
4	R	-
5	V	-
6	GR	-
7	B	-
9	G	-
11	BR	-
12	P	-
13	L	-
14	LG	-
15	O	-
18	B	-

Connector No.	B216
Connector Name	WIRE TO WIRE
Connector Type	NS18MBR-CS



Terminal No.	Color Of Wire	Signal Name [Specification]
1	LB	-
2	LG	-
3	G	-
4	GR	-
5	B	-
6	O	-

Connector No.	B219
Connector Name	OCCUPANT DETECTION SYSTEM CONTROL UNIT
Connector Type	TH04FW-RH



Terminal No.	Color Of Wire	Signal Name [Specification]
1	O	K-LINE
2	BR	CLUBS
3	BR	COMMUNICATION
4	W	IGN

Connector No.	B211
Connector Name	FRONT SATELLITE SENSOR RH
Connector Type	HK02FY-TV-EX



Terminal No.	Color Of Wire	Signal Name [Specification]
1	W/L	-
2	L/O	-

Connector No.	B212
Connector Name	SIDE AIR BAG MODULE RH
Connector Type	TK02FY-EX-TV



Terminal No.	Color Of Wire	Signal Name [Specification]
1	L	-
2	P	-

Connector No.	B213
Connector Name	SEAT BELT PRE-TENSIONER RH
Connector Type	ACB02FY



Terminal No.	Color Of Wire	Signal Name [Specification]
1	Y	-
2	L	-

Connector No.	B215
Connector Name	WIRE TO WIRE
Connector Type	TK04MY-ED



Terminal No.	Color Of Wire	Signal Name [Specification]
3	V	-
4	LG	-

Connector No.	B216
Connector Name	WIRE TO WIRE
Connector Type	NS18MBR-CS

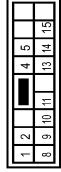

Terminal No.	Color Of Wire	Signal Name [Specification]
1	W	-
2	O	-
4	BR	-
5	Y	-
8	V	-
9	P	-
10	L	-
11	LG	-
13	G	-
14	SB	-
15	Y	-

A
B
C
D
E
F
G
H
I
J
K
L
M
N
O
P

SRC

JRHWC0965GB

SRS AIR BAG SYSTEM

< WIRING DIAGRAM >

SRS AIR BAG CONTROL SYSTEM

Connector No.	BZ17
Connector Name	REAR SATELLITE SENSOR RH
Connector Type	H002FY-1V-EX



Terminal No.	Color Of Wire	Signal Name [Specification]
1	G	-
2	R	-

Connector No.	BZ20
Connector Name	REAR CURTAIN AIR BAG MODULE RH
Connector Type	ACB02FY



Terminal No.	Color Of Wire	Signal Name [Specification]
1	L	-
2	P	-

Connector No.	BZ23
Connector Name	WIRE TO WIRE
Connector Type	NS16BW-GS



Terminal No.	Color Of Wire	Signal Name [Specification]
1	G	-
2	BR	-
3	LG	-
4	LO	-
5	B	-
6	G	-

Connector No.	BZ46
Connector Name	AIR BAG DIAGNOSIS SENSOR UNIT
Connector Type	NH22FY-2V-EX



Terminal No.	Color Of Wire	Signal Name [Specification]
12	Y	PRH(+)
13	L	PRH(-)
30	O	RH BUCKLE SW INPUT
33	L	SRH(+)
34	P	SRH(-)
37	L	RR GRH(+)
38	L	RR GRH(-)
39	L	FR GRH(+)
41	R	FR GRH(-)
42	V	SATELLITE RH(+)
48	W/L	SATELLITE RH(-)
50	L/O	SATELLITE RH(+)
56	SHIELD	GROUND
63	G	RR SATELLITE SENS RH-
64	R	RR SATELLITE SENS RH-

72	BR	ODS INPUT
----	----	-----------



Terminal No.	Color Of Wire	Signal Name [Specification]
50	L/P	-
51	Y	-

Connector No.	B530
Connector Name	WIRE TO WIRE
Connector Type	NS16BW-GS



Terminal No.	Color Of Wire	Signal Name [Specification]
1	R	-
2	R/G	-
3	R/W	-
4	W/R	-
5	W/L	-
6	Y	-
7	LG	-
8	BR	-
11	R	-
12	V	-
13	R/Y	-
14	G	-
15	P	-
16	L/P	-

Connector No.	B531
Connector Name	WIRE TO WIRE
Connector Type	NS16BW-GS



Terminal No.	Color Of Wire	Signal Name [Specification]
1	G	-
2	B	-
3	BR/W	-
4	Y	-
5	L/P	-
6	P	-

Connector No.	B538
Connector Name	SEAT BELT BUCKLE SWITCH (PASSENGER SIDE)
Connector Type	TK03MM



Terminal No.	Color Of Wire	Signal Name [Specification]
50	L/P	-
51	Y	-

JRHWC0966GB

SRS AIR BAG SYSTEM

< WIRING DIAGRAM >

SRS AIR BAG CONTROL SYSTEM

Connector No.	BS90
Connector Name	WIRE TO WIRE
Connector Type	MS96MM-CS



Terminal No.	Color Of Wire	Signal Name [Specification]
1	LG	-
2	BR	-
3	W	-
4	Y	-
5	L/P	-
6	P	-

Connector No.	D10
Connector Name	FRONT DOOR SATELLITE SENSOR LH
Connector Type	HK02FY-IV-EX



Terminal No.	Color Of Wire	Signal Name [Specification]
1	G	-
2	R	-

Connector No.	D21
Connector Name	WIRE TO WIRE
Connector Type	TH40FW-CS15



Terminal No.	Color Of Wire	Signal Name [Specification]
7	W	-
8	V	-
9	BR	-
10	LG	-
11	LG	-
12	R	-
14	B	-
15	W	-
16	P	-
17	Y	-
18	R	-
19	W	-
21	R	-
22	W	-
23	W	-
24	SHIELD	-
25	G	-
26	L	-
36	LG	-
37	Y	-
38	L	-
39	O	-
40	B	-
41	W	-
42	R	-
43	P	-
44	G	-
45	BR	-
46	W	-
51	V	-
52	LG	-
53	SHIELD	-
54	G	-
55	R	-

Connector No.	D41
Connector Name	WIRE TO WIRE
Connector Type	TH40FW-CS15



Terminal No.	Color Of Wire	Signal Name [Specification]
1	B	-
2	SB	-
4	O	-
5	BR	-
6	BR	-
7	GR	-
8	V	-
9	SB	-
10	LG	-
11	V	-
12	G	-
13	O	-
14	B	-
16	P	-
17	R	-
18	L	-
19	LG	-
20	GR	-
21	Y	-
22	BR	-
23	R	-
24	B	-
25	W	-
28	SHIELD	-
29	SB	-
30	G	-
31	W	-
32	W	-
33	V	-
34	BR	-
35	P	-

36	SB	-
37	GR	-
38	L	-
39	V	-
40	BR	-
41	P	-
42	V	-
43	Y	-
44	B	-
45	B	-
46	GR	-
48	W	-
47	P	-
48	B	-
49	G	-
50	SB	-
51	W	-
52	LG	-
53	SHIELD	-
54	G	-
55	R	-

Connector No.	D10
Connector Name	FRONT DOOR SATELLITE SENSOR RH
Connector Type	HK02FY-IV-EX



Terminal No.	Color Of Wire	Signal Name [Specification]
1	G	-
2	R	-

JRHWC0967GB

A
B
C
D
E
F
G
H
I
J
K
L
M
N
O
P

SRC

SRS AIR BAG SYSTEM

< WIRING DIAGRAM >

SRS AIR BAG CONTROL SYSTEM

Connector No.	E77
Connector Name	WIRE TO WIRE
Connector Type	RK03MB



Terminal No.	Color Of Wire	Signal Name [Specification]
1	SHIELD	-
2	SHIELD	-
3	W/R	-

Connector No.	E105
Connector Name	WIRE TO WIRE
Connector Type	TH70MW-CS10-M3



Terminal No.	Color Of Wire	Signal Name [Specification]
1	SHIELD	-
2	W	-
3	B	-
4	R	-
6	LG	-
7	R	-
8	GR	-
9	SB	-
10	BR	-
11	T	-
12	O	-
13	W	-
14	L	-
15	P	-
31	GR	-
32	R	-
33	W	-

37	BR	-
38	V	-
39	V	-
40	P	-
41	L	-
42	LG	-
43	O	-
45	GR	-
46	SB	-
47	V	-
49	L	-
51	BR	-
52	G	-
53	B	-
54	Y	-
55	Y	-
56	SHIELD	-
81	P	-
82	G	-
83	W/L	-
64	W/R	-
66	W	-
67	Y	-
69	SB	-
70	LG	-
71	R	-
72	L	-
73	GR	-
74	SB	-
75	SB	-
76	Y	-
77	G	-
78	O	-
80	R	-
81	L	-
82	LG	-
83	R	-

Connector No.	E311
Connector Name	WIRE TO WIRE
Connector Type	RK03FE-BD



Terminal No.	Color Of Wire	Signal Name [Specification]
1	SHIELD	-
2	SHIELD	-
3	L/O	-

Connector No.	E313
Connector Name	CRASH ZONE SENSOR
Connector Type	HK02FY-1V-EX-LC



Terminal No.	Color Of Wire	Signal Name [Specification]
1	W/L	-
2	L/O	-

Connector No.	M3
Connector Name	FUSE BLOCK (U/B)
Connector Type	MS12FW-CS

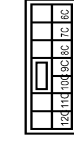

Terminal No.	Color Of Wire	Signal Name [Specification]
12C	G	-
12C	Y	-
12C	Y	-
7C	B/R	-
8C	G	-
9C	Y	-

Connector No.	M4
Connector Name	DATA LINK CONNECTOR
Connector Type	BD1FW

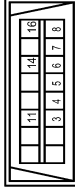

Terminal No.	Color Of Wire	Signal Name [Specification]
3	LG	-
4	B/R	-
5	B/R	-
6	L	-
7	R	-
8	G	-
11	SB	-
14	P	-
16	O	-

SRS AIR BAG SYSTEM

< WIRING DIAGRAM >

SRS AIR BAG CONTROL SYSTEM

Connector No.	M11
Connector Name	WIRE TO WIRE
Connector Type	TH40MW-CS10-M3

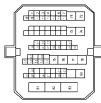

Terminal No.	Color Of Wire	Signal Name [Specification]
1	SHIELD	
2	P	
3	B	
4	R	
6	O	
7	G	
8	G	
9	B	
10	R	
11	W	
12	LG	
13	Y	
14	L	
15	P	
16	Y	
17	Y	
18	Y	
19	Y	
20	Y	
21	Y	
22	Y	
23	Y	
24	Y	
25	Y	
26	Y	
27	Y	
28	Y	
29	Y	
30	Y	
31	Y	
32	Y	
33	Y	
34	R/W	
35	GR	
36	LG	
37	W	
38	P	
39	V	
40	BR	
41	P	
42	V	
43	SB	
44	B	
45	W	
46	GR/V	
47	V	
48	B/W	
49	O	
50	Y	
51	LG	
52	BR	
53	LG	
54	GR	
55	B	
56	L	
61	BR	
62	LG	

63	W/L	--
64	W/R	--
65	SR	--
66	SR	--
67	SR	--
68	Y	--
69	Y	--
70	R	--
71	R	--
72	L	--
73	R	--
74	Y	--
75	G	--
76	V	--
77	P	--
78	W	--
79	W	--
80	W	--
81	L	--
82	L	--
83	R	--

Connector No.	M18
Connector Name	WIRE TO WIRE
Connector Type	TH40MW-CS15

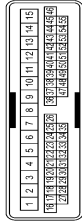

Terminal No.	Color Of Wire	Signal Name [Specification]
1	B/W	
2	R	
3	W	
4	Y	
5	SR	
6	BR	
7	LG	
8	L	
9	GR	
10	V	
11	V	
12	G	
13	O	
14	BR	
15	G	

Connector No.	M20
Connector Name	WIRE TO WIRE
Connector Type	TH40MW-CS15

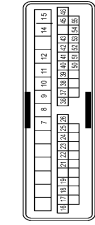

Terminal No.	Color Of Wire	Signal Name [Specification]
7	BR	
8	B	
9	B	
10	LG	
11	SB	
12	V	
14	B	
15	W	
16	BR	
17	P	
18	R	
19	Y	
20	B	
21	W	
22	B	
23	W	
24	SHIELD	
25	W/L	
26	W/R	
36	LG	
37	W	
38	P	
39	G	
40	B	
41	R	
42	L	
43	GR	
44	BR	
45	Y	
51	BR	
51	LG	
52	W	
53	SHIELD	
54	B/Y	

16	V	--
17	SR	--
18	SR	--
19	V	--
20	Y	--
21	W	--
22	G	--
23	R	--
24	B	--
25	W	--
26	SHIELD	--
27	GR	--
28	G	--
29	O	--
30	LG	--
31	W	--
32	L	--
33	Y	--
34	R/W	--
35	GR	--
36	LG	--
37	W	--
38	P	--
39	V	--
40	BR	--
41	P	--
42	V	--
43	SB	--
44	B	--
45	W	--
46	GR/V	--
47	V	--
48	B/P	--
49	O	--
49	R/W	--
50	V	--
51	LG	--
52	W	--
53	SHIELD	--
54	L/R	--
55	L/G	--

A
B
C
D
E
F
G
H
I
J
K
L
M
N
O
P

SRC

JRHWC0969GB

SRS AIR BAG SYSTEM

< WIRING DIAGRAM >

SRS AIR BAG CONTROL SYSTEM

35	LG	
----	----	--

Connector No.	M12
Connector Name	COMBINATION SWITCH (SPIRAL CABLE)
Connector Type	TR06FY-EX-1V



Terminal No.	Color Of Wire	Signal Name [Specification]
23	R	
29	V	
30	Y	

Connector No.	M34
Connector Name	COMBINATION METER
Connector Type	TH06FW-NH



Terminal No.	Color Of Wire	Signal Name [Specification]
1	O	BATTERY POWER SUPPLY
2	Y	IGNITION SIGNAL
3	B	GROUND
4	B	GROUND
8	B/P	ILLUMINATION CONTROL SIGNAL
9	B/P	ILLUMINATION CONTROL SIGNAL (+)
10	B	METER CONTROL SWITCH GROUND
11	G	METER CONTROL SWITCH SIGNAL
12	BR	SELECT SWITCH SIGNAL
13	Y	ILLUMINATION CONTROL SWITCH SIGNAL (+)
14	V	ILLUMINATION CONTROL SWITCH SIGNAL (-)
15	BR	AIR BAG SIGNAL
16	L	ENGINE COOLANT TEMPERATURE SIGNAL

18	LG	AMBIENT SENSOR SIGNAL
19	B	A/C AUTO AMP COMPRESSION REGULATION SIGNAL
20	Y	AMBIENT SENSOR GROUND
21	L	CAN-H
22	P	CAN-L
23	B	GROUND
24	B	FUEL LEVEL SENSOR GROUND
25	BR	ALTERNATOR SIGNAL
26	BR	PARKING BRAKE SWITCH SIGNAL
27	Y	BRAKE FLUID LEVEL SWITCH SIGNAL
28	V	SECURITY SIGNAL
29	G	WASHER LEVEL SWITCH SIGNAL
31	SB	VEHICLE SPEED SIGNAL (8-PULSE)
32	P	OVERDRIVE CONTROL SWITCH SIGNAL
33	B	VEHICLE SPEED SENSOR SIGNAL
34	P	SEAT BELT CATCHER SIGNAL
35	P	SEAT BELT CATCHER GROUND
36	BR	PASSENGER SEAT BELT WARNING SIGNAL

Connector No.	ME9
Connector Name	AIR BAG DIAGNOSIS SENSOR UNIT
Connector Type	NH28FY-EX

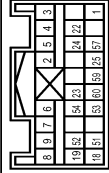

Terminal No.	Color Of Wire	Signal Name [Specification]
1	V	IGN
2	B/R	GROUND
3	G	DR1 (+)
4	Y	DR1 (-) DR2 (-)
5	V	DR2 (+)
6	SB	AST (+)
7	BR	AST (-)
8	G	AS2 (+)
9	R	AS2 (-)
10	W/R	EC2S (+)
18	W/R	EC2S (-)
22	GR	GROUND
23	BR	AIRBAG W/L
24	BR	SEATBELT W/L
25	LG	CUTOFF TELLTALE
51	B/Y	SIDE SENS RH2+
52	LG	SIDE SENS RH2-

53	L/R	SIDE SENS LH2+
54	L/G	SIDE SENS LH2-
57	O	DEPLOYMENT INFORMATION OUTPUT
58	L	CAN-H
60	P	CAN-L

Connector No.	ME3
Connector Name	PASSENGER AIR BAG MODULE
Connector Type	IR04FY-BD



Terminal No.	Color Of Wire	Signal Name [Specification]
1	SB	
2	BR	
3	G	
4	R	

Connector No.	M7D
Connector Name	WIRE TO WIRE
Connector Type	NS16E8R-GS



Terminal No.	Color Of Wire	Signal Name [Specification]
1	V	
2	P	
5	L	
8	G	
9	V	
10	R/L	
11	SB	
13	Y	

14	P	
15	W	

Connector No.	M123
Connector Name	BCM (BODY CONTROL MODULE)
Connector Type	FEA06FY-FAAE-SA



Terminal No.	Color Of Wire	Signal Name [Specification]
56	P	INT ROOM LAMP PWR SPALY
57	GR	BAT
58	O	AIR BAG
59	SB	PASS DOOR/LINK OUTPUT
60	V	TURN SIG LH OUTPUT
61	G	TURN SIG RH OUTPUT
62	W	STEP LAMP CONT
63	R	INT ROOM LAMP CONT
64	LG	CRANK RELO
65	V	ALL DOOR LOCK OUTPUT
66	G	DR DOOR LOCK OUTPUT
67	B	CRANK RELO
68	L	PW PWR SPALY (2SA)
69	P	PW PWR SPALY (BAT1)
70	L	BAT

Connector No.	M12B
Connector Name	PASSENGER AIR BAG OFF INDICATOR
Connector Type	TH06FW-NH



JRHWC0970GB

SRS AIR BAG SYSTEM

< WIRING DIAGRAM >

SRS AIR BAG CONTROL SYSTEM

Terminal No.	Color Of Wire	Signal Name [Specification]
1	LS	--
4	B/W	--

Connector No.	M300
Connector Name	DRIVER AIR BAG MODULE
Connector Type	ACAM2FOR



Terminal No.	Color Of Wire	Signal Name [Specification]
9	--	--
12	--	--

Connector No.	M301
Connector Name	DRIVER AIR BAG MODULE
Connector Type	ACAM2FF-2V



Terminal No.	Color Of Wire	Signal Name [Specification]
10	--	--
11	--	--

Connector No.	RI03
Connector Name	WIRE TO WIRE
Connector Type	TK08FG-Y



Terminal No.	Color Of Wire	Signal Name [Specification]
1	Y	--
2	B	--
3	GR	--
6	LG	--

Connector No.	RI04
Connector Name	FRONT CURTAIN AIR BAG MODULE RH
Connector Type	ACB08FY



Terminal No.	Color Of Wire	Signal Name [Specification]
1	R	--
2	G	--

Connector No.	RI05
Connector Name	FRONT CURTAIN AIR BAG MODULE LH
Connector Type	ACB08FOR



Terminal No.	Color Of Wire	Signal Name [Specification]
1	Y	--
2	BR	--

A
B
C
D
E
F
G
SRC
I
J
K
L
M
N
O
P

JRHWC0971GB

DIAGNOSIS AND REPAIR WORK FLOW

< BASIC INSPECTION >

BASIC INSPECTION

DIAGNOSIS AND REPAIR WORK FLOW

Work Flow

INFOID:000000009649850

OVERALL SEQUENCE

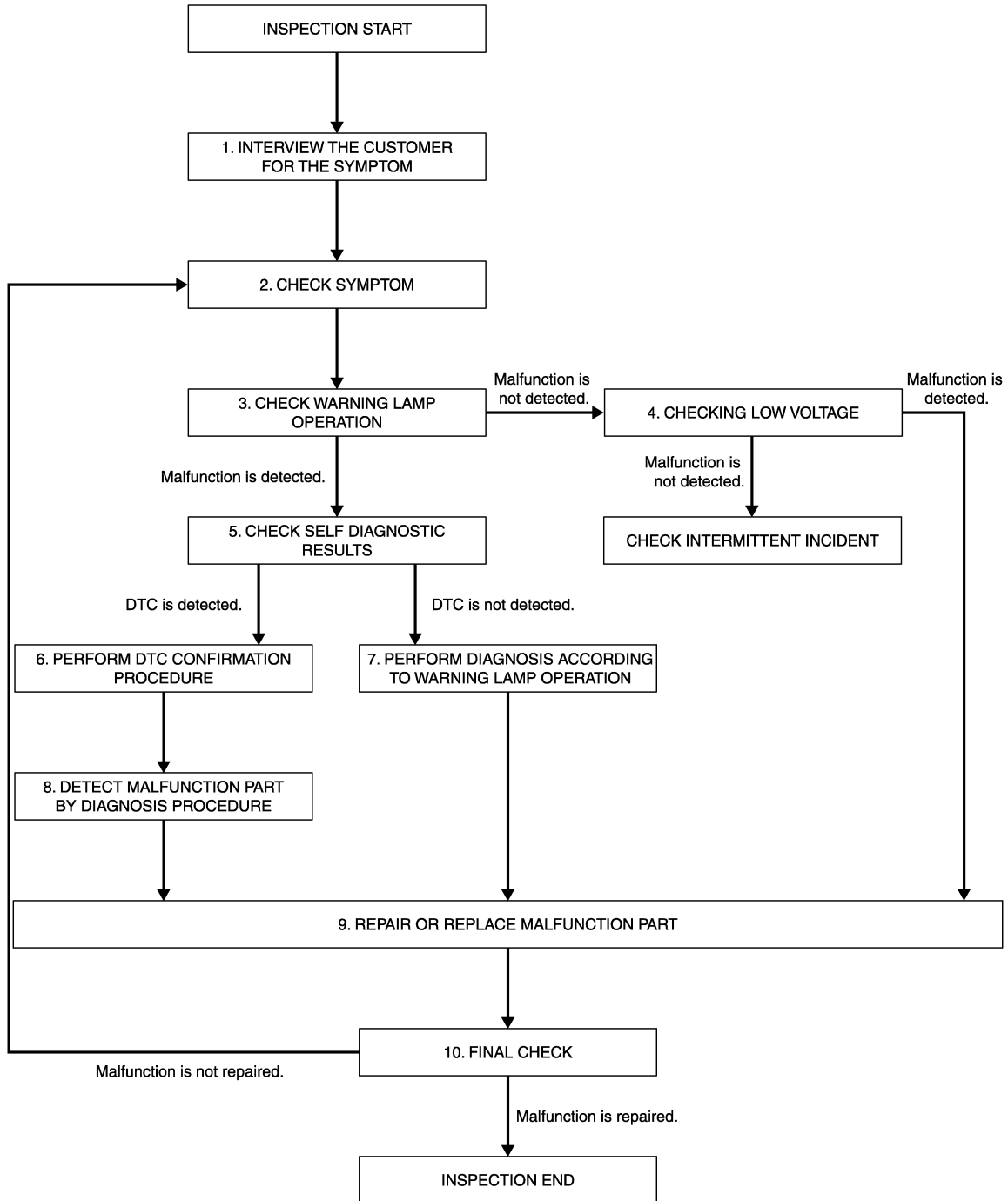

JMHIA1324GB

DETAILED FLOW

DIAGNOSIS AND REPAIR WORK FLOW

< BASIC INSPECTION >

1. INTERVIEW THE CUSTOMER FOR THE SYMPTOM

Interview the customer for the symptom (the condition and the environment when the incident/malfunction occurs).

>> GO TO 2.

2. CHECK SYMPTOM

Check the symptom from the customer information.

>> GO TO 3.

3. CHECK WARNING LAMP OPERATION

Check air bag warning lamp operation in the user mode. Refer to [SRC-15, "On Board Diagnosis Function"](#).

Are any malfunction detected?

YES >> GO TO 5.

NO >> GO TO 4.

4. CHECK LOW VOLTAGE

Check low voltage with CONSULT. Refer to [SRC-19, "CONSULT Function"](#).

Are any malfunction detected?

YES >> GO TO 9.

NO >> Check intermittent incident. Refer to [GI-42, "Intermittent Incident"](#).

5. CHECK SELF DIAGNOSTIC RESULTS

Check self diagnostic result with CONSULT or diagnosis mode.

If it is impossible to switch to diagnosis mode, follow the same procedure that DTC is not detected.

NOTE:

Perform the following procedure if DTC is detected.

- Record DTC (Print them out with CONSULT.)
- Erase self diagnostic result.
- Study the relationship between the malfunction that DTC or air bag warning lamp indicates and the symptom that the customer describes.
- Check related service bulletins for information.

Is DTC detected?

YES >> GO TO 6.

NO >> GO TO 7.

6. PERFORM DTC CONFIRMATION PROCEDURE

Perform DTC CONFIRMATION PROCEDURE for the DTC.

>> GO TO 8.

7. PERFORM DIAGNOSIS ACCORDING TO WARNING LAMP OPERATION

1. Check air bag warning lamp operation in the user mode. Refer to [SRC-15, "On Board Diagnosis Function"](#).
2. Perform Diagnosis Procedure for the air bag warning lamp operation. Refer to [SRC-15, "On Board Diagnosis Function"](#) (USER MODE).

>> GO TO 9.

8. DETECT MALFUNCTIONING PART BY DIAGNOSTIC PROCEDURE

Inspect according to Diagnostic Procedure of the DTC.

>> GO TO 9.

9. REPAIR OR REPLACE THE MALFUNCTION PART

A
B
C
D
E
F
G
I
J
K
L
M
N
O
P

SRC

DIAGNOSIS AND REPAIR WORK FLOW

< BASIC INSPECTION >

Repair or replace the malfunctioning part.

>> GO TO 10.

10.FINAL CHECK

Check self diagnostic result and air bag warning lamp operation in the user mode.

Is the malfunction repaired?

YES >> INSPECTION END

NO >> GO TO 2.

INSPECTION AND ADJUSTMENT

< BASIC INSPECTION >

INSPECTION AND ADJUSTMENT

ADDITIONAL SERVICE WHEN REPLACING CONTROL UNIT

ADDITIONAL SERVICE WHEN REPLACING CONTROL UNIT : Description

INFOID:000000009649851

When replacing or removing and installing passenger seat, always perform zero point reset so that Occupant Detection System is activated normally.

ADDITIONAL SERVICE WHEN REPLACING CONTROL UNIT : Special Repair Requirement

INFOID:000000009649852

WORK PROCEDURE WHEN REPLACING CONTROL UNIT

1.PERFORM ZERO POINT RESET

Perform zero point reset. Refer to [SRC-41, "ZERO POINT RESET : Special Repair Requirement"](#).

>> END

ZERO POINT RESET

ZERO POINT RESET : Description

INFOID:000000009649853

Zero point reset is an initializing procedure for occupant detection sensor that must be performed when replacing or removing and installing passenger seat.

If zero point reset is not performed, the initialization is incomplete and Occupant Detection System does not operate normally.

NOTE:

- When replacing passenger seat with a NISSAN genuine part, air bag warning lamp blinks if zero point reset is incomplete.
- When zero point reset is performed once after removal and installation of passenger seat, CONSULT displays "complete" and air bag warning does not blink.
- When reinstalling passenger seat after removal, the initial value for occupant detection sensor changes, and Occupant Detection System does not operate normally.
- Always perform zero point reset after performing the work as per the following.
 - Reinstallation of passenger seat
 - Replacement of passenger seat with a seat that is zero point reset complete.

ZERO POINT RESET : Special Repair Requirement

INFOID:000000009649854

1.PERFORM ZERO POINT RESET

1. Perform zero point reset.

NOTE:

When performing zero point reset, be careful of the items described as per the following.

- Perform zero point reset after installing passenger seat to the vehicle
 - Do not put any objects on passenger seat
 - Do not apply excessive vibration to the vehicle
 - Do not touch the vehicle
 - Do not tilt the vehicle
2. Select start on "Zero point reset function" screen from, WORK SUPPORT of CONSULT "OCCUPANT DETECTION".
 3. "Zero point reset" starts.

>> GO TO 2.

2.CONFIRMATION OF SETTING

1. Proceed to "Zero point reset function" screen from work support of CONSULT "OCCUPANT DETECTION".
2. Check that "Complete" or "Incomplete" is displayed on "Zero point reset status".

CAUTION:

INSPECTION AND ADJUSTMENT

< BASIC INSPECTION >

- “Complete” is displayed on “zero point reset current status” if the seat is reinstalled by seat removal and installation, or “zero point reset” is already performed.
- “Zero point reset current status” displays “Incomplete” if a new seat is installed. When turning key switch ON without performing zero point reset, air bag warning lamp blinks. When zero point reset is performed, air bag warning lamp turns OFF.
- Air bag warning lamp blinks in user mode only.
- Air bag sensor unit does not record whether or not zero point reset is performed.

Is condition “ALREADY PERFORMED”?

YES >> Print out “ZERO POINT RESET CURRENT STATUS” screen, and inspection end.

NO >> Check condition as per the following, and perform zero point reset again.

- Passenger seat is occupied by an object.
- Excessive vibration is applied while performing zero point reset.
- Occupant detection system is malfunctioning.

NOTE:

If “Incomplete” is displayed on “zero point reset current status”, zero point reset is not completed normally. Check the condition as per the following and perform zero point reset again.

- Passenger seat is occupied by an object.
- Excessive vibration is applied while performing zero point reset.
- Occupant detection system is malfunctioning.

B1001, B1002, B1003, B1004, B1005 DIAGNOSIS SENSOR UNIT

< DTC/CIRCUIT DIAGNOSIS >

DTC/CIRCUIT DIAGNOSIS

B1001, B1002, B1003, B1004, B1005 DIAGNOSIS SENSOR UNIT

DTC Logic

INFOID:000000009649855

DTC DETECTION LOGIC

DTC	Display contents of CONSULT	DTC detecting condition	Possible cause
B1001 B1002 B1003 B1004 B1005	CONTROL UNIT	Air bag diagnosis sensor unit is malfunctioning	Malfunction in air bag diagnosis sensor unit

DTC CONFIRMATION PROCEDURE

1.CHECK SELF-DIAG RESULT

With CONSULT

1. Turn ignition switch ON.
2. Perform "Self Diagnostic Result" mode of "AIR BAG" using CONSULT.

Without CONSULT

1. Turn ignition switch ON.
2. Check the air bag warning lamp status. Refer to [SRC-15, "On Board Diagnosis Function"](#).

NOTE:

SRS does not enter the diagnosis mode if no malfunction is detected in the user mode.

Is malfunctioning part detected?

- YES >> Refer to [SRC-43, "Diagnosis Procedure"](#).
NO >> INSPECTION END

Diagnosis Procedure

INFOID:000000009649856

WARNING:

- Before servicing, turn ignition switch OFF, disconnect battery negative terminal, and wait 3 minutes or more. (To discharge backup capacitor.)
- Never use unspecified tester or other measuring device.

1.CHECK HARNESS CONNECTOR

Check the harness connector.

Is the inspection result normal?

- YES >> GO TO 2.
NO >> Replace harness connectors.

2.CHECK WIRING HARNESS

Check the wiring harness externals.

Is the inspection result normal?

- YES >> GO TO 3.
NO >> Replace wiring harness.

3.REPLACE AIR BAG DIAGNOSIS SENSOR UNIT

1. Replace air bag diagnosis sensor unit. Refer to [SR-29, "Removal and Installation"](#).
2. Perform DTC confirmation procedure. Refer to [SRC-43, "DTC Logic"](#).

Is DTC detected?

- YES >> GO TO 1.
NO >> INSPECTION END

B1006, B1007, B1008, B1009, B1010 DIAGNOSIS SENSOR UNIT

< DTC/CIRCUIT DIAGNOSIS >

B1006, B1007, B1008, B1009, B1010 DIAGNOSIS SENSOR UNIT

DTC Logic

INFOID:000000009649857

DTC DETECTION LOGIC

DTC	Display contents of CONSULT	DTC detecting condition	Possible cause
B1006 B1007 B1008 B1009 B1010	CONTROL UNIT	Air bag diagnosis sensor unit is malfunctioning	Malfunction in air bag diagnosis sensor unit

DTC CONFIRMATION PROCEDURE

1. CHECK SELF-DIAG RESULT

With CONSULT

1. Turn ignition switch ON.
2. Perform "Self Diagnostic Result" mode of "AIR BAG" using CONSULT.

Without CONSULT

1. Turn ignition switch ON.
2. Check the air bag warning lamp status. Refer to [SRC-15, "On Board Diagnosis Function"](#).

NOTE:

SRS does not enter the diagnosis mode if no malfunction is detected in the user mode.

Is malfunctioning part detected?

- YES >> Refer to [SRC-44, "Diagnosis Procedure"](#).
NO >> INSPECTION END

Diagnosis Procedure

INFOID:000000009649858

WARNING:

- Before servicing, turn ignition switch OFF, disconnect battery negative terminal, and wait 3 minutes or more. (To discharge backup capacitor.)
- Never use unspecified tester or other measuring device.

1. CHECK HARNESS CONNECTOR

Check the harness connector.

Is the inspection result normal?

- YES >> GO TO 2.
NO >> Replace harness connectors.

2. CHECK WIRING HARNESS

Check the wiring harness externals.

Is the inspection result normal?

- YES >> GO TO 3.
NO >> Replace wiring harness.

3. REPLACE AIR BAG DIAGNOSIS SENSOR UNIT

1. Replace air bag diagnosis sensor unit. Refer to [SR-29, "Removal and Installation"](#)
2. Perform DTC confirmation procedure. Refer to [SRC-44, "DTC Logic"](#)

Is DTC detected?

- YES >> GO TO 1.
NO >> INSPECTION END

B1011, B1012, B1013, B1014, B1015 DIAGNOSIS SENSOR UNIT

< DTC/CIRCUIT DIAGNOSIS >

B1011, B1012, B1013, B1014, B1015 DIAGNOSIS SENSOR UNIT

DTC Logic

INFOID:000000009649859

DTC DETECTION LOGIC

DTC	Display contents of CONSULT	DTC detecting condition	Possible cause
B1011 B1012 B1013 B1014 B1015	CONTROL UNIT	Air bag diagnosis sensor unit is malfunctioning	Malfunction in air bag diagnosis sensor unit

DTC CONFIRMATION PROCEDURE

1. CHECK SELF-DIAG RESULT

With CONSULT

- Turn ignition switch ON.
- Perform "Self Diagnostic Result" mode of "AIR BAG" using CONSULT.

Without CONSULT

- Turn ignition switch ON.
- Check the air bag warning lamp status. Refer to [SRC-15, "On Board Diagnosis Function"](#).

NOTE:

SRS does not enter the diagnosis mode if no malfunction is detected in the user mode.

Is malfunctioning part detected?

- YES >> Refer to [SRC-45, "Diagnosis Procedure"](#).
NO >> INSPECTION END

Diagnosis Procedure

INFOID:000000009649860

WARNING:

- Before servicing, turn ignition switch OFF, disconnect battery negative terminal, and wait 3 minutes or more. (To discharge backup capacitor.)
- Never use unspecified tester or other measuring device.

1. CHECK HARNESS CONNECTOR

Check the harness connector.

Is the inspection result normal?

- YES >> GO TO 2.
NO >> Replace harness connectors.

2. CHECK WIRING HARNESS

Check the wiring harness externals.

Is the inspection result normal?

- YES >> GO TO 3.
NO >> Replace wiring harness.

3. REPLACE AIR BAG DIAGNOSIS SENSOR UNIT

- Replace air bag diagnosis sensor unit. Refer to [SR-29, "Removal and Installation"](#)
- Perform DTC confirmation procedure. Refer to [SRC-45, "DTC Logic"](#)

Is DTC detected?

- YES >> GO TO 1.
NO >> INSPECTION END

B1017, B1020, B1021 OCCUPANT SENS C/U

< DTC/CIRCUIT DIAGNOSIS >

B1017, B1020, B1021 OCCUPANT SENS C/U

DTC Logic

INFOID:000000009649861

DTC DETECTION LOGIC

DTC	Display contents of CONSULT	DTC detecting condition	Possible cause
B1017 B1020 B1021	OCCUPANT SENS C/U [UNIT FAIL]	Trouble occurs in Occupant Detection System control unit	<ul style="list-style-type: none">• Disconnection of wiring harness• Malfunction in Occupant Detection System control unit• Malfunction in air bag diagnosis sensor unit

DTC CONFIRMATION PROCEDURE

1. CHECK SELF-DIAG RESULT

With CONSULT

1. Turn ignition switch ON.
2. Perform "AIR BAG" Self Diagnostic Result CONSULT.

Without CONSULT

1. Turn ignition switch ON.
2. Check the air bag warning lamp status. Refer to [SRC-15, "On Board Diagnosis Function"](#).

NOTE:

SRS does not enter diagnosis mode if no malfunction is detected in user mode.

Is malfunctioning part detected?

- YES >> Refer to [SRC-46, "Diagnosis Procedure"](#).
NO >> INSPECTION END

Diagnosis Procedure

INFOID:000000009649862

WARNING:

- Before servicing, turn ignition switch OFF, disconnect battery negative terminal and wait at least 3 minutes. (To discharge backup capacitor.)
- Never use unspecified tester or other measuring device.

DIAGNOSTIC PROCEDURE

1. CHECK HARNESS CONNECTOR

Check the connection of harness connector.

Is the inspection result normal?

- YES >> GO TO 2.
NO >> Replace harness connectors.

2. CHECK WIRING HARNESS

Check the wiring harness externals.

Is the inspection result normal?

- YES >> GO TO 3.
NO >> Replace wiring harness.

3. REPLACE OCCUPANT DETECTION SYSTEM CONTROL UNIT

1. Replace occupant detection system control unit. Refer to [SR-32, "Removal and Installation"](#).
2. Perform DTC confirmation procedure. Refer to [SRC-46, "DTC Logic"](#).

Is DTC detected?

- YES >> GO TO 4.
NO >> INSPECTION END

4. REPLACE OCCUPANT DETECTION SYSTEM SEAT SENSOR

B1017, B1020, B1021 OCCUPANT SENS C/U

< DTC/CIRCUIT DIAGNOSIS >

1. Replace passenger seat cushion frame. Refer to [SE-85. "Exploded View"](#) (Manual seat) or [SE-99. "Exploded View"](#) (Power seat).
2. Perform DTC confirmation procedure. Refer to [SRC-46. "DTC Logic"](#).

Is DTC detected?

YES >> GO TO 5.

NO >> INSPECTION END

5. REPLACE AIR BAG DIAGNOSIS SENSOR UNIT

1. Replace air bag diagnosis sensor unit. Refer to [SR-29. "Removal and Installation"](#).
2. Perform DTC confirmation procedure. Refer to [SRC-46. "DTC Logic"](#).

Is DTC detected?

YES >> GO TO 1.

NO >> INSPECTION END

A

B

C

D

E

F

G

SRC

I

J

K

L

M

N

O

P

B1018 OCCUPANT SENS

< DTC/CIRCUIT DIAGNOSIS >

B1018 OCCUPANT SENS

DTC Logic

INFOID:000000009649863

DTC DETECTION LOGIC

DTC	Display contents of CONSULT	DTC detecting condition	Possible cause
B1018	OCCUPANT SENS [UNIT FAIL]	Malfunction occurs in Occupant Detection System sensor	<ul style="list-style-type: none">• Disconnection of wiring harness• Malfunction in Occupant Detection System sensor• Malfunction in Occupant Detection System control unit• Malfunction in air bag diagnosis sensor unit

DTC CONFIRMATION PROCEDURE

1. CHECK SELF-DIAG RESULT

With CONSULT

1. Turn ignition switch ON.
2. Perform "AIR BAG" Self Diagnostic Result CONSULT.

Without CONSULT

1. Turn ignition switch ON.
2. Check the air bag warning lamp status. Refer to [SRC-15, "On Board Diagnosis Function"](#).

NOTE:

SRS does not enter diagnosis mode if no malfunction is detected in user mode.

Is malfunctioning part detected?

- YES >> Refer to [SRC-48, "Diagnosis Procedure"](#).
NO >> INSPECTION END

Diagnosis Procedure

INFOID:000000009649864

WARNING:

- Before servicing, turn ignition switch OFF, disconnect battery negative terminal and wait at least 3 minutes. (To discharge backup capacitor.)
- Never use unspecified tester or other measuring device.

DIAGNOSTIC PROCEDURE

1. CHECK HARNESS CONNECTOR

Check the connection of harness connector.

Is the inspection result normal?

- YES >> GO TO 2.
NO >> Replace harness connectors.

2. CHECK WIRING HARNESS

Check the wiring harness externals.

Is the inspection result normal?

- YES >> GO TO 3.
NO >> Replace wiring harness.

3. REPLACE OCCUPANT DETECTION SYSTEM CONTROL UNIT

1. Replace occupant detection system control unit. Refer to [SR-32, "Removal and Installation"](#).
2. Perform DTC confirmation procedure. Refer to [SRC-48, "DTC Logic"](#).

Is DTC detected?

- YES >> GO TO 4.
NO >> INSPECTION END

B1018 OCCUPANT SENS

< DTC/CIRCUIT DIAGNOSIS >

4. REPLACE OCCUPANT DETECTION SYSTEM SEAT SENSOR

1. Replace passenger seat cushion frame. Refer to [SE-85. "Exploded View"](#) (Manual seat) or [SE-99. "Exploded View"](#) (Power seat).
2. Perform DTC confirmation procedure. Refer to [SRC-48. "DTC Logic"](#).

Is DTC detected?

YES >> GO TO 5.

NO >> INSPECTION END

5. REPLACE AIR BAG DIAGNOSIS SENSOR UNIT

1. Replace air bag diagnosis sensor unit. Refer to [SR-29. "Removal and Installation"](#).
2. Perform DTC confirmation procedure. Refer to [SRC-48. "DTC Logic"](#).

Is DTC detected?

YES >> GO TO 1.

NO >> INSPECTION END

A
B
C
D
E
F
G
I
J
K
L
M
N
O
P

SRC

B1022 OCCUPANT SENS C/U

< DTC/CIRCUIT DIAGNOSIS >

B1022 OCCUPANT SENS C/U

DTC Logic

INFOID:000000009649865

DTC DETECTION LOGIC

DTC	Display contents of CONSULT	DTC detecting condition	Possible cause
B1022	OCCUPANT SENS C/U [COMM FAIL]	Malfunction occurs in Occupant Detection System control unit, circuit of Occupant Detection System control unit-Air bag diagnosis sensor unit or Air bag diagnosis sensor unit	<ul style="list-style-type: none">• Disconnection of wiring harness• Malfunction in Occupant Detection System control unit• Malfunction in air bag diagnosis sensor unit

DTC CONFIRMATION PROCEDURE

1. CHECK SELF-DIAG RESULT

With CONSULT

1. Turn ignition switch ON.
2. Perform "AIR BAG" Self Diagnostic Result CONSULT.

Without CONSULT

1. Turn ignition switch ON.
2. Check the air bag warning lamp status. Refer to [SRC-15, "On Board Diagnosis Function"](#).

NOTE:

SRS does not enter diagnosis mode if no malfunction is detected in user mode.

Is malfunctioning part detected?

- YES >> Refer to [SRC-50, "Diagnosis Procedure"](#).
NO >> INSPECTION END

Diagnosis Procedure

INFOID:000000009649866

WARNING:

- Before servicing, turn ignition switch OFF, disconnect battery negative terminal and wait at least 3 minutes. (To discharge backup capacitor.)
- Never use unspecified tester or other measuring device.

DIAGNOSTIC PROCEDURE

1. CHECK HARNESS CONNECTOR

Check the connection of harness connector.

Is the inspection result normal?

- YES >> GO TO 2.
NO >> Replace harness connectors.

2. CHECK WIRING HARNESS

Check the wiring harness externals.

Is the inspection result normal?

- YES >> GO TO 3.
NO >> Replace wiring harness.

3. REPLACE OCCUPANT DETECTION SYSTEM CONTROL UNIT

1. Replace occupant detection system control unit. Refer to [SR-32, "Removal and Installation"](#).
2. Perform DTC confirmation procedure. Refer to [SRC-50, "DTC Logic"](#).

Is DTC detected?

- YES >> GO TO 4.
NO >> INSPECTION END

4. REPLACE OCCUPANT DETECTION SYSTEM SEAT SENSOR

B1022 OCCUPANT SENS C/U

< DTC/CIRCUIT DIAGNOSIS >

1. Replace passenger seat cushion frame. Refer to [SE-85. "Exploded View"](#) (Manual seat) or [SE-99. "Exploded View"](#) (Power seat).
2. Perform DTC confirmation procedure. Refer to [SRC-50. "DTC Logic"](#).

Is DTC detected?

YES >> GO TO 5.

NO >> INSPECTION END

5.REPLACE AIR BAG DIAGNOSIS SENSOR UNIT

1. Replace air bag diagnosis sensor unit. Refer to [SR-29. "Removal and Installation"](#).
2. Perform DTC confirmation procedure. Refer to [SRC-50. "DTC Logic"](#).

Is DTC detected?

YES >> GO TO 1.

NO >> INSPECTION END

A
B
C
D
E
F
G
I
J
K
L
M
N
O
P

SRC

B1023 PASS A/B INDCTR CKT

< DTC/CIRCUIT DIAGNOSIS >

B1023 PASS A/B INDCTR CKT

DTC Logic

INFOID:000000009649867

DTC DETECTION LOGIC

DTC	Display contents of CONSULT	DTC detecting condition	Possible cause
B1023	PASS A/B INDCTR CKT [UNIT FAIL]	Passenger air bag OFF indicator circuit is open or shorted to ground or the circuits are shorted each other	<ul style="list-style-type: none">• Disconnection of wiring harness• Malfunction in front passenger air bag OFF indicator• Malfunction in air bag diagnosis sensor unit

DTC CONFIRMATION PROCEDURE

1. CHECK SELF-DIAG RESULT

With CONSULT

1. Turn ignition switch ON.
2. Perform "AIR BAG" Self Diagnostic Result CONSULT.

Without CONSULT

1. Turn ignition switch ON.
2. Check the air bag warning lamp status. Refer to [SRC-15, "On Board Diagnosis Function"](#).

NOTE:

SRS does not enter diagnosis mode if no malfunction is detected in user mode.

Is malfunctioning part detected?

YES >> Refer to [SRC-52, "Diagnosis Procedure"](#).

NO >> INSPECTION END

Diagnosis Procedure

INFOID:000000009649868

WARNING:

- Before servicing, turn ignition switch OFF, disconnect battery negative terminal and wait at least 3 minutes. (To discharge backup capacitor.)
- Never use unspecified tester or other measuring device.

DIAGNOSTIC PROCEDURE

1. CHECK HARNESS CONNECTOR

Check the connection of harness connector.

Is the inspection result normal?

YES >> GO TO 2.

NO >> Replace harness connectors.

2. CHECK WIRING HARNESS

Check the wiring harness externals.

Is the inspection result normal?

YES >> GO TO 3.

NO >> Replace wiring harness.

3. CHECK PASSENGER AIR BAG OFF INDICATOR

1. Replace passenger air bag OFF indicator.
2. Perform DTC confirmation procedure. Refer to [SRC-52, "DTC Logic"](#).

Is DTC detected?

YES >> GO TO 4.

NO >> INSPECTION END

4. REPLACE AIR BAG DIAGNOSIS SENSOR UNIT

1. Replace air bag diagnosis sensor unit. Refer to [SR-29, "Removal and Installation"](#).

B1023 PASS A/B INDCTR CKT

< DTC/CIRCUIT DIAGNOSIS >

2. Perform DTC confirmation procedure. Refer to [SRC-52. "DTC Logic"](#).

Is DTC detected?

YES >> GO TO 1.

NO >> INSPECTION END

A

B

C

D

E

F

G

SRC

I

J

K

L

M

N

O

P

B1025, B1032, B1048 OCS SENSOR

< DTC/CIRCUIT DIAGNOSIS >

B1025, B1032, B1048 OCS SENSOR

DTC Logic

INFOID:000000009649869

DTC DETECTION LOGIC

DTC	Display contents of CONSULT	DTC detecting condition	Possible cause
B1025 B1032 B1048	OCS SENSOR	Malfunction occurs in Occupant Detection System control unit, circuit of Occupant Detection System control unit-Air bag diagnosis sensor unit or Air bag diagnosis sensor unit	<ul style="list-style-type: none">• Disconnection of wiring harness• Internal breakdown in Occupant Detection System control unit• Malfunction in air bag diagnosis sensor unit

DTC CONFIRMATION PROCEDURE

1. CHECK SELF-DIAG RESULT

With CONSULT

1. Turn ignition switch ON.
2. Perform "AIR BAG" Self Diagnostic Result CONSULT.

Without CONSULT

1. Turn ignition switch ON.
2. Check the air bag warning lamp status. Refer to [SRC-15, "On Board Diagnosis Function"](#).

NOTE:

SRS does not enter diagnosis mode if no malfunction is detected in user mode.

Is malfunctioning part detected?

- YES >> Refer to [SRC-54, "Diagnosis Procedure"](#).
NO >> INSPECTION END

Diagnosis Procedure

INFOID:000000009649870

WARNING:

- Before servicing, turn ignition switch OFF, disconnect battery negative terminal and wait at least 3 minutes. (To discharge backup capacitor.)
- Never use unspecified tester or other measuring device.

DIAGNOSTIC PROCEDURE

1. CHECK HARNESS CONNECTOR

Check the connection of harness connector.

Is the inspection result normal?

- YES >> GO TO 2.
NO >> Replace harness connectors.

2. CHECK WIRING HARNESS

Check the wiring harness externals.

Is the inspection result normal?

- YES >> GO TO 3.
NO >> Replace wiring harness.

3. REPLACE OCCUPANT DETECTION SYSTEM CONTROL UNIT

1. Replace occupant detection system control unit. Refer to [SR-32, "Removal and Installation"](#).
2. Perform DTC confirmation procedure. Refer to [SRC-54, "DTC Logic"](#).

Is DTC detected?

- YES >> GO TO 4.
NO >> INSPECTION END

4. REPLACE OCCUPANT DETECTION SYSTEM SEAT SENSOR

B1025, B1032, B1048 OCS SENSOR

< DTC/CIRCUIT DIAGNOSIS >

1. Replace passenger seat cushion frame. Refer to [SE-85. "Exploded View"](#) (Manual seat) or [SE-99. "Exploded View"](#) (Power seat).
2. Perform DTC confirmation procedure. Refer to [SRC-54. "DTC Logic"](#).

Is DTC detected?

YES >> GO TO 5.

NO >> INSPECTION END

5. REPLACE AIR BAG DIAGNOSIS SENSOR UNIT

1. Replace air bag diagnosis sensor unit. Refer to [SR-29. "Removal and Installation"](#).
2. Perform DTC confirmation procedure. Refer to [SRC-54. "DTC Logic"](#).

Is DTC detected?

YES >> GO TO 1.

NO >> INSPECTION END

A
B
C
D
E
F
G
I
J
K
L
M
N
O
P

SRC

B1026, B1027, B1028, B1029, B1030, B1031 DIAGNOSIS SENSOR UNIT

< DTC/CIRCUIT DIAGNOSIS >

B1026, B1027, B1028, B1029, B1030, B1031 DIAGNOSIS SENSOR UNIT

DTC Logic

INFOID:000000009649871

DTC DETECTION LOGIC

DTC	Display contents of CONSULT	DTC detecting condition	Possible cause
B1026 B1027 B1028 B1029 B1030 B1031	CONTROL UNIT	Air bag diagnosis sensor unit is malfunctioning	Malfunction in air bag diagnosis sensor unit

DTC CONFIRMATION PROCEDURE

1. CHECK SELF-DIAG RESULT

With CONSULT

1. Turn ignition switch ON.
2. Perform "Self Diagnostic Result" mode of "AIR BAG" using CONSULT.

Without CONSULT

1. Turn ignition switch ON.
2. Check the air bag warning lamp status. Refer to [SRC-15, "On Board Diagnosis Function"](#).

NOTE:

SRS does not enter the diagnosis mode if no malfunction is detected in the user mode.

Is malfunctioning part detected?

- YES >> Refer to [SRC-56, "Diagnosis Procedure"](#).
NO >> INSPECTION END

Diagnosis Procedure

INFOID:000000009649872

WARNING:

- Before servicing, turn ignition switch OFF, disconnect battery negative terminal, and wait 3 minutes or more. (To discharge backup capacitor.)
- Never use unspecified tester or other measuring device.

1. CHECK HARNESS CONNECTOR

Check the harness connector.

Is the inspection result normal?

- YES >> GO TO 2.
NO >> Replace harness connectors.

2. CHECK WIRING HARNESS

Check the wiring harness externals.

Is the inspection result normal?

- YES >> GO TO 3.
NO >> Replace wiring harness.

3. REPLACE AIR BAG DIAGNOSIS SENSOR UNIT

1. Replace air bag diagnosis sensor unit. Refer to [SR-29, "Removal and Installation"](#).
2. Perform DTC confirmation procedure. Refer to [SRC-56, "DTC Logic"](#).

Is DTC detected?

- YES >> GO TO 1.
NO >> INSPECTION END

B1033, B1034 CRASH ZONE SENSOR

< DTC/CIRCUIT DIAGNOSIS >

B1033, B1034 CRASH ZONE SENSOR

DTC Logic

INFOID:000000009649873

DTC DETECTION LOGIC

DTC	Display contents of CONSULT	DTC detecting condition	Possible cause
B1033 B1034	CRASH ZONE SEN [UNIT FAIL]	Crash zone sensor is malfunctioning	<ul style="list-style-type: none">• Disconnection of wiring harness• Malfunction in crash zone sensor• Malfunction in air bag diagnosis sensor unit

DTC CONFIRMATION PROCEDURE

1. CHECK SELF-DIAG RESULT

With CONSULT

1. Turn ignition switch ON.
2. Perform "Self Diagnostic Result" mode of "AIR BAG" using CONSULT.

Without CONSULT

1. Turn ignition switch ON.
2. Check the air bag warning lamp status. Refer to [SRC-15, "On Board Diagnosis Function"](#).

NOTE:

SRS does not enter the diagnosis mode if no malfunction is detected in the user mode.

Is malfunctioning part detected?

- YES >> Refer to [SRC-57, "Diagnosis Procedure"](#).
NO >> INSPECTION END

Diagnosis Procedure

INFOID:000000009649874

WARNING:

- Before servicing, turn ignition switch OFF, disconnect battery negative terminal, and wait 3 minutes or more. (To discharge backup capacitor.)
- Never use unspecified tester or other measuring device.

1. CHECK HARNESS CONNECTOR

Check the harness connector.

Is the inspection result normal?

- YES >> GO TO 2.
NO >> Replace harness connectors.

2. CHECK WIRING HARNESS

Check the wiring harness externals.

Is the inspection result normal?

- YES >> GO TO 3.
NO >> Replace wiring harness.

3. REPLACE CRASH ZONE SENSOR

1. Replace crash zone sensor. Refer to [SR-23, "Removal and Installation"](#).
2. Perform DTC confirmation procedure. Refer to [SRC-57, "DTC Logic"](#).

Is DTC detected?

- YES >> GO TO 4.
NO >> INSPECTION END

4. REPLACE AIR BAG DIAGNOSIS SENSOR UNIT

1. Replace air bag diagnosis sensor unit. Refer to [SR-29, "Removal and Installation"](#).
2. Perform DTC confirmation procedure. Refer to [SRC-57, "DTC Logic"](#).

Is DTC detected?

- YES >> GO TO 1.

B1033, B1034 CRASH ZONE SENSOR

< DTC/CIRCUIT DIAGNOSIS >

NO >> INSPECTION END

B1035 CRASH ZONE SENSOR

< DTC/CIRCUIT DIAGNOSIS >

B1035 CRASH ZONE SENSOR

DTC Logic

INFOID:000000009649875

DTC DETECTION LOGIC

DTC	Display contents of CONSULT	DTC detecting condition	Possible cause
B1035	CRASH ZONE SEN [COMM FAIL]	Crash zone sensor is malfunctioning or out of the specified specification	<ul style="list-style-type: none">• Disconnection of wiring harness• Malfunction in crash zone sensor• Malfunction in air bag diagnosis sensor unit

DTC CONFIRMATION PROCEDURE

1. CHECK SELF-DIAG RESULT

With CONSULT

1. Turn ignition switch ON.
2. Perform "Self Diagnostic Result" mode of "AIR BAG" using CONSULT.

Without CONSULT

1. Turn ignition switch ON.
2. Check the air bag warning lamp status. Refer to [SRC-15, "On Board Diagnosis Function"](#).

NOTE:

SRS does not enter the diagnosis mode if no malfunction is detected in the user mode.

Is malfunctioning part detected?

- YES >> Refer to [SRC-59, "Diagnosis Procedure"](#).
NO >> INSPECTION END

Diagnosis Procedure

INFOID:000000009649876

WARNING:

- Before servicing, turn ignition switch OFF, disconnect battery negative terminal, and wait 3 minutes or more. (To discharge backup capacitor.)
- Never use unspecified tester or other measuring device.

1. CHECK HARNESS CONNECTOR

Check the harness connector.

Is the inspection result normal?

- YES >> GO TO 2.
NO >> Replace harness connectors.

2. CHECK WIRING HARNESS

Check the wiring harness externals.

Is the inspection result normal?

- YES >> GO TO 3.
NO >> Replace wiring harness.

3. REPLACE CRASH ZONE SENSOR

1. Replace crash zone sensor. Refer to [SR-23, "Removal and Installation"](#).
2. Perform DTC confirmation procedure. Refer to [SRC-59, "DTC Logic"](#).

Is DTC detected?

- YES >> GO TO 4.
NO >> INSPECTION END

4. REPLACE AIR BAG DIAGNOSIS SENSOR UNIT

1. Replace air bag diagnosis sensor unit. Refer to [SR-29, "Removal and Installation"](#).
2. Perform DTC confirmation procedure. Refer to [SRC-59, "DTC Logic"](#).

Is DTC detected?

- YES >> GO TO 1.

B1035 CRASH ZONE SENSOR

< DTC/CIRCUIT DIAGNOSIS >

NO >> INSPECTION END

B1036 CRASH ZONE SENSOR

< DTC/CIRCUIT DIAGNOSIS >

B1036 CRASH ZONE SENSOR

DTC Logic

INFOID:000000009649877

DTC DETECTION LOGIC

DTC	Display contents of CONSULT	DTC detecting condition	Possible cause
B1036	CRASH ZONE SEN [UNMATCH]	Crash zone sensor is out of the specified specification	Diagnosis sensor unit or crash zone sensor is different from the part specified

DTC CONFIRMATION PROCEDURE

1. CHECK SELF-DIAG RESULT

With CONSULT

1. Turn ignition switch ON.
2. Perform "Self Diagnostic Result" mode of "AIR BAG" using CONSULT.

Without CONSULT

1. Turn ignition switch ON.
2. Check the air bag warning lamp status. Refer to [SRC-15, "On Board Diagnosis Function"](#).

NOTE:

SRS does not enter the diagnosis mode if no malfunction is detected in the user mode.

Is malfunctioning part detected?

- YES >> Refer to [SRC-61, "Diagnosis Procedure"](#).
NO >> INSPECTION END

Diagnosis Procedure

INFOID:000000009649878

WARNING:

- Before servicing, turn ignition switch OFF, disconnect battery negative terminal, and wait 3 minutes or more. (To discharge backup capacitor.)
- Never use unspecified tester or other measuring device.

1. REPLACE CRASH ZONE SENSOR

1. Replace crash zone sensor. Refer to [SR-23, "Removal and Installation"](#).
2. Perform DTC confirmation procedure. Refer to [SRC-61, "DTC Logic"](#).

Is DTC detected?

- YES >> GO TO 2.
NO >> INSPECTION END

2. REPLACE AIR BAG DIAGNOSIS SENSOR UNIT

1. Replace air bag diagnosis sensor unit. Refer to [SR-29, "Removal and Installation"](#).
2. Perform DTC confirmation procedure. Refer to [SRC-61, "DTC Logic"](#).

Is DTC detected?

- YES >> GO TO 1.
NO >> INSPECTION END

B1037, B1039, B1041 CRASH ZONE SENSOR

< DTC/CIRCUIT DIAGNOSIS >

B1037, B1039, B1041 CRASH ZONE SENSOR

DTC Logic

INFOID:000000009649879

DTC DETECTION LOGIC

DTC	Display contents of CONSULT	DTC detecting condition	Possible cause
B1037 B1039 B1041	CRASH ZONE SENS1	Crash zone sensor is malfunctioning	<ul style="list-style-type: none">• Disconnection of wiring harness• Malfunction in crash zone sensor• Malfunction in air bag diagnosis sensor unit

DTC CONFIRMATION PROCEDURE

1. CHECK SELF-DIAG RESULT

With CONSULT

1. Turn ignition switch ON.
2. Perform "Self Diagnostic Result" mode of "AIR BAG" using CONSULT.

Without CONSULT

1. Turn ignition switch ON.
2. Check the air bag warning lamp status. Refer to [SRC-15, "On Board Diagnosis Function"](#).

NOTE:

SRS does not enter the diagnosis mode if no malfunction is detected in the user mode.

Is malfunctioning part detected?

- YES >> Refer to [SRC-62, "Diagnosis Procedure"](#).
NO >> INSPECTION END

Diagnosis Procedure

INFOID:000000009649880

WARNING:

- Before servicing, turn ignition switch OFF, disconnect battery negative terminal, and wait 3 minutes or more. (To discharge backup capacitor.)
- Never use unspecified tester or other measuring device.

1. CHECK HARNESS CONNECTOR

Check the harness connector.

Is the inspection result normal?

- YES >> GO TO 2.
NO >> Replace harness connectors.

2. CHECK WIRING HARNESS

Check the wiring harness externals.

Is the inspection result normal?

- YES >> GO TO 3.
NO >> Replace wiring harness.

3. REPLACE CRASH ZONE SENSOR

1. Replace crash zone sensor. Refer to [SR-23, "Removal and Installation"](#).
2. Perform DTC confirmation procedure. Refer to [SRC-62, "DTC Logic"](#).

Is DTC detected?

- YES >> GO TO 4.
NO >> INSPECTION END

4. REPLACE AIR BAG DIAGNOSIS SENSOR UNIT

1. Replace air bag diagnosis sensor unit. Refer to [SR-29, "Removal and Installation"](#).
2. Perform DTC confirmation procedure. Refer to [SRC-62, "DTC Logic"](#).

Is DTC detected?

- YES >> GO TO 1.

B1037, B1039, B1041 CRASH ZONE SENSOR

< DTC/CIRCUIT DIAGNOSIS >

NO >> INSPECTION END

A

B

C

D

E

F

G

SRC

I

J

K

L

M

N

O

P

B1042, B1043, B1044, B1045, B1046, B1047 DIAGNOSIS SENSOR UNIT

< DTC/CIRCUIT DIAGNOSIS >

B1042, B1043, B1044, B1045, B1046, B1047 DIAGNOSIS SENSOR UNIT

DTC Logic

INFOID:000000009649881

DTC DETECTION LOGIC

DTC	Display contents of CONSULT	DTC detecting condition	Possible cause
B1042 B1043 B1044 B1045 B1046 B1047	CONTROL UNIT	Air bag diagnosis sensor unit is malfunctioning	Malfunction in air bag diagnosis sensor unit

DTC CONFIRMATION PROCEDURE

1. CHECK SELF-DIAG RESULT

With CONSULT

1. Turn ignition switch ON.
2. Perform "Self Diagnostic Result" mode of "AIR BAG" using CONSULT.

Without CONSULT

1. Turn ignition switch ON.
2. Check the air bag warning lamp status. Refer to [SRC-15, "On Board Diagnosis Function"](#).

NOTE:

SRS does not enter the diagnosis mode if no malfunction is detected in the user mode.

Is malfunctioning part detected?

- YES >> Refer to [SRC-64, "Diagnosis Procedure"](#).
NO >> INSPECTION END

Diagnosis Procedure

INFOID:000000009649882

WARNING:

- Before servicing, turn ignition switch OFF, disconnect battery negative terminal, and wait 3 minutes or more. (To discharge backup capacitor.)
- Never use unspecified tester or other measuring device.

1. CHECK HARNESS CONNECTOR

Check the harness connector.

Is the inspection result normal?

- YES >> GO TO 2.
NO >> Replace harness connectors.

2. CHECK WIRING HARNESS

Check the wiring harness externals.

Is the inspection result normal?

- YES >> GO TO 3.
NO >> Replace wiring harness.

3. REPLACE AIR BAG DIAGNOSIS SENSOR UNIT

1. Replace air bag diagnosis sensor unit. Refer to [SR-29, "Removal and Installation"](#).
2. Perform DTC confirmation procedure. Refer to [SRC-64, "DTC Logic"](#).

Is DTC detected?

- YES >> GO TO 1.
NO >> INSPECTION END

B1049, B1054 DRIVER AIR BAG MODULE

< DTC/CIRCUIT DIAGNOSIS >

B1049, B1054 DRIVER AIR BAG MODULE

DTC Logic

INFOID:000000009649883

DTC DETECTION LOGIC

DTC	Display contents of CONSULT	DTC detecting condition	Possible cause
B1049 B1054	DRIVER AIRBAG MODULE [OPEN]	Driver air bag module circuit is open (including the spiral cable)	<ul style="list-style-type: none">• Harness or connectors (The module circuit is open.)• Malfunction in driver air bag module• Malfunction in spiral cable• Malfunction in air bag diagnosis sensor unit

DTC CONFIRMATION PROCEDURE

1.CHECK SELF-DIAG RESULT

With CONSULT

1. Turn ignition switch ON.
2. Perform "Self Diagnostic Result" mode of "AIR BAG" using CONSULT.

Without CONSULT

1. Turn ignition switch ON.
2. Check the air bag warning lamp status. Refer to [SRC-15, "On Board Diagnosis Function"](#).

NOTE:

SRS does not enter the diagnosis mode if no malfunction is detected in the user mode.

Is malfunctioning part detected?

- YES >> Refer to [SRC-65, "Diagnosis Procedure"](#).
NO >> INSPECTION END

Diagnosis Procedure

INFOID:000000009649884

WARNING:

- Before servicing, turn ignition switch OFF, disconnect battery negative terminal, and wait 3 minutes or more. (To discharge backup capacitor.)
- Never use unspecified tester or other measuring device.

1.CHECK HARNESS CONNECTOR

Check the harness connector.

Is the inspection result normal?

- YES >> GO TO 2.
NO >> Replace harness connector.

2.CHECK WIRING HARNESS

Check the wiring harness externals.

Is the inspection result normal?

- YES >> GO TO 3.
NO >> Replace wiring harness.

3.CHECK SPIRAL CABLE CIRCUIT

1. Turn ignition switch OFF.
2. Disconnect driver air bag module harness connector and combination switch (spiral cable) harness connector.
3. Check continuity between driver air bag module harness connector and combination switch (spiral cable) harness connector.

B1049, B1054 DRIVER AIR BAG MODULE

< DTC/CIRCUIT DIAGNOSIS >

Driver air bag module		Combination switch (spiral cable)		Continuity
Connector	Terminal	Connector	Terminal	
M301	10	M32	28	Existed
	11		30	
M300	12		29	
	9		30	

4. Check continuity between driver air bag module harness connector and ground.

Driver side air bag module		Ground	Continuity
Connector	Terminal		
M301	10	Ground	Not existed
	11		
M300	12		
	9		

Is the inspection result normal?

YES >> GO TO 4.

NO >> Replace combination switch (spiral cable). Refer to [SR-15, "Removal and Installation"](#).

4. REPLACE AIR BAG DIAGNOSIS SENSOR UNIT

1. Replace air bag diagnosis sensor unit. Refer to [SR-29, "Removal and Installation"](#).
2. Perform DTC confirmation procedure. Refer to [SRC-65, "DTC Logic"](#).

Is DTC detected?

YES >> GO TO 5.

NO >> INSPECTION END

5. REPLACE DRIVER AIR BAG MODULE

1. Replace driver air bag module. Refer to [SR-12, "Removal and Installation"](#).
2. Perform DTC confirmation procedure. Refer to [SRC-65, "DTC Logic"](#).

Is DTC detected?

YES >> GO TO 1.

NO >> INSPECTION END

B1050, B1055 DRIVER AIR BAG MODULE

< DTC/CIRCUIT DIAGNOSIS >

B1050, B1055 DRIVER AIR BAG MODULE

DTC Logic

INFOID:000000009649885

DTC DETECTION LOGIC

DTC	Display contents of CONSULT	DTC detecting condition	Possible cause
B1050 B1055	DRIVER AIRBAG MODULE [VB-SHORT]	Driver air bag module circuit is shorted to power supply circuit (including the spiral cable)	<ul style="list-style-type: none">• Harness or connectors (The module circuit is shorted.)• Malfunction in driver air bag module• Malfunction in spiral cable• Malfunction in air bag diagnosis sensor unit

DTC CONFIRMATION PROCEDURE

1. CHECK SELF-DIAG RESULT

With CONSULT

1. Turn ignition switch ON.
2. Perform "Self Diagnostic Result" mode of "AIR BAG" using CONSULT.

Without CONSULT

1. Turn ignition switch ON.
2. Check the air bag warning lamp status. Refer to [SRC-15, "On Board Diagnosis Function"](#).

NOTE:

SRS does not enter the diagnosis mode if no malfunction is detected in the user mode.

Is malfunctioning part detected?

- YES >> Refer to [SRC-67, "Diagnosis Procedure"](#).
NO >> INSPECTION END

Diagnosis Procedure

INFOID:000000009649886

WARNING:

- Before servicing, turn ignition switch OFF, disconnect battery negative terminal, and wait 3 minutes or more. (To discharge backup capacitor.)
- Never use unspecified tester or other measuring device.

1. CHECK HARNESS CONNECTOR

Check the harness connector.

Is the inspection result normal?

- YES >> GO TO 2.
NO >> Replace harness connector.

2. CHECK WIRING HARNESS

Check the wiring harness externals.

Is the inspection result normal?

- YES >> GO TO 3.
NO >> Replace wiring harness.

3. REPLACE SPIRAL CABLE

1. Replace combination switch (spiral cable). Refer to [SR-15, "Removal and Installation"](#).
2. Perform DTC confirmation procedure. Refer to [SRC-67, "DTC Logic"](#).

Is DTC detected?

- YES >> GO TO 4.
NO >> INSPECTION END

4. REPLACE AIR BAG DIAGNOSIS SENSOR UNIT

1. Replace air bag diagnosis sensor unit. Refer to [SR-29, "Removal and Installation"](#).
2. Perform DTC confirmation procedure. Refer to [SRC-67, "DTC Logic"](#).

B1050, B1055 DRIVER AIR BAG MODULE

< DTC/CIRCUIT DIAGNOSIS >

Is DTC detected?

YES >> GO TO 5.

NO >> INSPECTION END

5.REPLACE DRIVER AIR BAG MODULE

1. Replace driver air bag module. Refer to [SR-12, "Removal and Installation"](#).

2. Perform DTC confirmation procedure. Refer to [SRC-67, "DTC Logic"](#).

Is DTC detected?

YES >> GO TO 1.

NO >> INSPECTION END

B1051, B1056 DRIVER AIR BAG MODULE

< DTC/CIRCUIT DIAGNOSIS >

B1051, B1056 DRIVER AIR BAG MODULE

DTC Logic

INFOID:000000009649887

DTC DETECTION LOGIC

DTC	Display contents of CONSULT	DTC detecting condition	Possible cause
B1051 B1056	DRIVER AIRBAG MODULE [GND-SHORT]	Driver air bag module circuit is shorted to ground (including the spiral cable)	<ul style="list-style-type: none">• Harness or connectors (The module circuit is shorted.)• Malfunction in driver air bag module• Malfunction in spiral cable• Malfunction in air bag diagnosis sensor unit

DTC CONFIRMATION PROCEDURE

1.CHECK SELF-DIAG RESULT

With CONSULT

1. Turn ignition switch ON.
2. Perform "Self Diagnostic Result" mode of "AIR BAG" using CONSULT.

Without CONSULT

1. Turn ignition switch ON.
2. Check the air bag warning lamp status. Refer to [SRC-15, "On Board Diagnosis Function"](#).

NOTE:

SRS does not enter the diagnosis mode if no malfunction is detected in the user mode.

Is malfunctioning part detected?

- YES >> Refer to [SRC-69, "Diagnosis Procedure"](#).
NO >> INSPECTION END

Diagnosis Procedure

INFOID:000000009649888

WARNING:

- Before servicing, turn ignition switch OFF, disconnect battery negative terminal, and wait 3 minutes or more. (To discharge backup capacitor.)
- Never use unspecified tester or other measuring device.

1.CHECK HARNESS CONNECTOR

Check the harness connector.

Is the inspection result normal?

- YES >> GO TO 2.
NO >> Replace harness connector.

2.CHECK WIRING HARNESS

Check the wiring harness externals.

Is the inspection result normal?

- YES >> GO TO 3.
NO >> Replace wiring harness.

3.CHECK SPIRAL CABLE CIRCUIT

1. Turn ignition switch OFF.
2. Disconnect driver air bag module harness connector and combination switch (spiral cable) harness connector.
3. Check continuity between driver air bag module harness connector and combination switch (spiral cable) harness connector.

B1051, B1056 DRIVER AIR BAG MODULE

< DTC/CIRCUIT DIAGNOSIS >

Driver air bag module		Combination switch (spiral cable)		Continuity
Connector	Terminal	Connector	Terminal	
M301	10	M32	28	Existed
	11		30	
M300	12		29	
	9		30	

4. Check continuity between driver air bag module harness connector and ground.

Driver side air bag module		Ground	Continuity
Connector	Terminal		
M301	10	Ground	Not existed
	11		
M300	12		
	9		

Is the inspection result normal?

YES >> GO TO 4.

NO >> Replace combination switch (spiral cable). Refer to [SR-15, "Removal and Installation"](#).

4. REPLACE AIR BAG DIAGNOSIS SENSOR UNIT

1. Replace air bag diagnosis sensor unit. Refer to [SR-29, "Removal and Installation"](#).
2. Perform DTC confirmation procedure. Refer to [SRC-69, "DTC Logic"](#).

Is DTC detected?

YES >> GO TO 5.

NO >> INSPECTION END

5. REPLACE DRIVER AIR BAG MODULE

1. Replace driver air bag module. Refer to [SR-12, "Removal and Installation"](#).
2. Perform DTC confirmation procedure. Refer to [SRC-69, "DTC Logic"](#).

Is DTC detected?

YES >> GO TO 1.

NO >> INSPECTION END

B1052, B1057 DRIVER AIR BAG MODULE

< DTC/CIRCUIT DIAGNOSIS >

B1052, B1057 DRIVER AIR BAG MODULE

DTC Logic

INFOID:000000009649889

DTC DETECTION LOGIC

DTC	Display contents of CONSULT	DTC detecting condition	Possible cause
B1052 B1057	DRIVER AIRBAG MODULE [SHORT]	Driver air bag module circuit are shorted to each other (including the spiral cable)	<ul style="list-style-type: none">• Harness or connectors (The module circuit is shorted.)• Malfunction in driver air bag module• Malfunction in spiral cable• Malfunction in air bag diagnosis sensor unit

DTC CONFIRMATION PROCEDURE

1.CHECK SELF-DIAG RESULT

With CONSULT

1. Turn ignition switch ON.
2. Perform "Self Diagnostic Result" mode of "AIR BAG" using CONSULT.

Without CONSULT

1. Turn ignition switch ON.
2. Check the air bag warning lamp status. Refer to [SRC-15, "On Board Diagnosis Function"](#).

NOTE:

SRS does not enter the diagnosis mode if no malfunction is detected in the user mode.

Is malfunctioning part detected?

- YES >> Refer to [SRC-71, "Diagnosis Procedure"](#).
NO >> INSPECTION END

Diagnosis Procedure

INFOID:000000009649890

WARNING:

- Before servicing, turn ignition switch OFF, disconnect battery negative terminal, and wait 3 minutes or more. (To discharge backup capacitor.)
- Never use unspecified tester or other measuring device.

1.CHECK HARNESS CONNECTOR

Check the harness connector.

Is the inspection result normal?

- YES >> GO TO 2.
NO >> Replace harness connector.

2.CHECK WIRING HARNESS

Check the wiring harness externals.

Is the inspection result normal?

- YES >> GO TO 3.
NO >> Replace wiring harness.

3.CHECK SPIRAL CABLE CIRCUIT-I

1. Turn ignition switch OFF.
2. Disconnect driver air bag module harness connector and combination switch (spiral cable) harness connector.
3. Check continuity between combination switch (spiral cable) terminals.

B1052, B1057 DRIVER AIR BAG MODULE

< DTC/CIRCUIT DIAGNOSIS >

Combination switch (spiral cable)				Continuity
Connector	Terminal	Connector	Terminal	
M301	10	M301	11	Not existed
		M300	9	
			12	

Is the inspection result normal?

YES >> GO TO 4.

NO >> Replace combination switch (spiral cable). Refer to [SR-15. "Removal and Installation"](#).

4. CHECK SPIRAL CABLE CIRCUIT-II

Check continuity between combination switch (spiral cable) terminals.

Combination switch (spiral cable)			Continuity
Connector	Terminal	Terminal	
M32	28	29	Not existed
		30	

Is the inspection result normal?

YES >> GO TO 5.

NO >> Replace combination switch (spiral cable). Refer to [SR-15. "Removal and Installation"](#).

5. REPLACE AIR BAG DIAGNOSIS SENSOR UNIT

1. Replace air bag diagnosis sensor unit. Refer to [SR-29. "Removal and Installation"](#).

2. Perform DTC confirmation procedure. Refer to [SRC-71. "DTC Logic"](#).

Is DTC detected?

YES >> GO TO 6.

NO >> INSPECTION END

6. REPLACE DRIVER AIR BAG MODULE

1. Replace driver air bag module. Refer to [SR-12. "Removal and Installation"](#).

2. Perform DTC confirmation procedure. Refer to [SRC-71. "DTC Logic"](#).

Is DTC detected?

YES >> GO TO 1.

NO >> INSPECTION END

B1058, B1059, B1060, B1061, B1062, B1063 DIAGNOSIS SENSOR UNIT

< DTC/CIRCUIT DIAGNOSIS >

B1058, B1059, B1060, B1061, B1062, B1063 DIAGNOSIS SENSOR UNIT

DTC Logic

INFOID:000000009649891

DTC DETECTION LOGIC

DTC	Display contents of CONSULT	DTC detecting condition	Possible cause
B1058 B1059 B1060 B1061 B1062 B1063	CONTROL UNIT	Air bag diagnosis sensor unit is malfunctioning	Malfunction in air bag diagnosis sensor unit

DTC CONFIRMATION PROCEDURE

1. CHECK SELF-DIAG RESULT

With CONSULT

1. Turn ignition switch ON.
2. Perform "Self Diagnostic Result" mode of "AIR BAG" using CONSULT.

Without CONSULT

1. Turn ignition switch ON.
2. Check the air bag warning lamp status. Refer to [SRC-15, "On Board Diagnosis Function"](#).

NOTE:

SRS does not enter the diagnosis mode if no malfunction is detected in the user mode.

Is malfunctioning part detected?

- YES >> Refer to [SRC-73, "Diagnosis Procedure"](#).
NO >> INSPECTION END

Diagnosis Procedure

INFOID:000000009649892

WARNING:

- Before servicing, turn ignition switch OFF, disconnect battery negative terminal, and wait 3 minutes or more. (To discharge backup capacitor.)
- Never use unspecified tester or other measuring device.

1. CHECK HARNESS CONNECTOR

Check the harness connector.

Is the inspection result normal?

- YES >> GO TO 2.
NO >> Replace harness connectors.

2. CHECK WIRING HARNESS

Check the wiring harness externals.

Is the inspection result normal?

- YES >> GO TO 3.
NO >> Replace wiring harness.

3. REPLACE AIR BAG DIAGNOSIS SENSOR UNIT

1. Replace air bag diagnosis sensor unit. Refer to [SR-29, "Removal and Installation"](#).
2. Perform DTC confirmation procedure. Refer to [SRC-73, "DTC Logic"](#).

Is DTC detected?

- YES >> GO TO 1.
NO >> INSPECTION END

B1065, B1070 PASSENGER AIR BAG MODULE

< DTC/CIRCUIT DIAGNOSIS >

B1065, B1070 PASSENGER AIR BAG MODULE

DTC Logic

INFOID:000000009649893

DTC DETECTION LOGIC

DTC	Display contents of CONSULT	DTC detecting condition	Possible cause
B1065 B1070	ASSIST A/B MODULE [OPEN]	Passenger air bag module circuit is open	<ul style="list-style-type: none">• Disconnection of wiring harness and open• Malfunction in passenger air bag module• Malfunction in air bag diagnosis sensor unit

DTC CONFIRMATION PROCEDURE

1. CHECK SELF-DIAG RESULT

With CONSULT

1. Turn ignition switch ON.
2. Perform "Self Diagnostic Result" mode of "AIR BAG" using CONSULT.

Without CONSULT

1. Turn ignition switch ON.
2. Check the air bag warning lamp status. Refer to [SRC-15, "On Board Diagnosis Function"](#).

NOTE:

SRS does not enter the diagnosis mode if no malfunction is detected in the user mode.

Is malfunctioning part detected?

- YES >> Refer to [SRC-74, "Diagnosis Procedure"](#).
NO >> INSPECTION END

Diagnosis Procedure

INFOID:000000009649894

WARNING:

- Before servicing, turn ignition switch OFF, disconnect battery negative terminal, and wait at least 3 minutes or more. (To discharge backup capacitor.)
- Never use unspecified tester or other measuring device.

1. CHECK HARNESS CONNECTOR

Check the harness connector.

Is the inspection result normal?

- YES >> GO TO 2.
NO >> Replace harness connector.

2. CHECK WIRING HARNESS

Check the wiring harness externals.

Is the inspection result normal?

- YES >> GO TO 3.
NO >> Replace wiring harness.

3. REPLACE AIR BAG DIAGNOSIS SENSOR UNIT

1. Replace air bag diagnosis sensor unit. Refer to [SR-29, "Removal and Installation"](#).
2. Perform DTC confirmation procedure. Refer to [SRC-74, "DTC Logic"](#).

Is DTC detected?

- YES >> GO TO 4.
NO >> INSPECTION END

4. REPLACE PASSENGER AIR BAG MODULE

1. Replace passenger air bag module. Refer to [SR-18, "Removal and Installation"](#).
2. Perform DTC confirmation procedure. Refer to [SRC-74, "DTC Logic"](#).

Is DTC detected?

- YES >> GO TO 1.

B1065, B1070 PASSENGER AIR BAG MODULE

< DTC/CIRCUIT DIAGNOSIS >

NO >> INSPECTION END

A

B

C

D

E

F

G

SRC

I

J

K

L

M

N

O

P

B1066, B1071 PASSENGER AIR BAG MODULE

< DTC/CIRCUIT DIAGNOSIS >

B1066, B1071 PASSENGER AIR BAG MODULE

DTC Logic

INFOID:000000009649895

DTC DETECTION LOGIC

DTC	Display contents of CONSULT	DTC detecting condition	Possible cause
B1066 B1071	ASSIST A/B MODULE [VB-SHORT]	Passenger air bag module circuit is shorted to power supply circuit	<ul style="list-style-type: none">• Disconnection of wiring harness and short• Malfunction in passenger air bag module• Malfunction in air bag diagnosis sensor unit

DTC CONFIRMATION PROCEDURE

1. CHECK SELF-DIAG RESULT

With CONSULT

1. Turn ignition switch ON.
2. Perform "Self Diagnostic Result" mode of "AIR BAG" using CONSULT.

Without CONSULT

1. Turn ignition switch ON.
2. Check the air bag warning lamp status. Refer to [SRC-15, "On Board Diagnosis Function"](#).

NOTE:

SRS does not enter the diagnosis mode if no malfunction is detected in the user mode.

Is malfunctioning part detected?

- YES >> Refer to [SRC-76, "Diagnosis Procedure"](#).
NO >> INSPECTION END

Diagnosis Procedure

INFOID:000000009649896

WARNING:

- Before servicing, turn ignition switch OFF, disconnect battery negative terminal, and wait at least 3 minutes or more. (To discharge backup capacitor.)
- Never use unspecified tester or other measuring device.

1. CHECK HARNESS CONNECTOR

Check the harness connector.

Is the inspection result normal?

- YES >> GO TO 2.
NO >> Replace harness connector.

2. CHECK WIRING HARNESS

Check the wiring harness externals.

Is the inspection result normal?

- YES >> GO TO 3.
NO >> Replace wiring harness.

3. REPLACE AIR BAG DIAGNOSIS SENSOR UNIT

1. Replace air bag diagnosis sensor unit. Refer to [SR-29, "Removal and Installation"](#).
2. Perform DTC confirmation procedure. Refer to [SRC-76, "DTC Logic"](#).

Is DTC detected?

- YES >> GO TO 4.
NO >> INSPECTION END

4. REPLACE PASSENGER AIR BAG MODULE

1. Replace passenger air bag module. Refer to [SR-18, "Removal and Installation"](#).
2. Perform DTC confirmation procedure. Refer to [SRC-76, "DTC Logic"](#).

Is DTC detected?

- YES >> GO TO 1.

B1066, B1071 PASSENGER AIR BAG MODULE

< DTC/CIRCUIT DIAGNOSIS >

NO >> INSPECTION END

A

B

C

D

E

F

G

SRC

I

J

K

L

M

N

O

P

B1067, B1072 PASSENGER AIR BAG MODULE

< DTC/CIRCUIT DIAGNOSIS >

B1067, B1072 PASSENGER AIR BAG MODULE

DTC Logic

INFOID:000000009649897

DTC DETECTION LOGIC

DTC	Display contents of CONSULT	DTC detecting condition	Possible cause
B1067 B1072	ASSIST A/B MODULE [GND-SHORT]	Passenger air bag module circuit is shorted to ground	<ul style="list-style-type: none">• Disconnection of wiring harness and short• Malfunction in passenger air bag module• Malfunction in air bag diagnosis sensor unit

DTC CONFIRMATION PROCEDURE

1. CHECK SELF-DIAG RESULT

With CONSULT

1. Turn ignition switch ON.
2. Perform "Self Diagnostic Result" mode of "AIR BAG" using CONSULT.

Without CONSULT

1. Turn ignition switch ON.
2. Check the air bag warning lamp status. Refer to [SRC-15, "On Board Diagnosis Function"](#).

NOTE:

SRS does not enter the diagnosis mode if no malfunction is detected in the user mode.

Is malfunctioning part detected?

- YES >> Refer to [SRC-78, "Diagnosis Procedure"](#).
NO >> INSPECTION END

Diagnosis Procedure

INFOID:000000009649898

WARNING:

- Before servicing, turn ignition switch OFF, disconnect battery negative terminal, and wait at least 3 minutes or more. (To discharge backup capacitor.)
- Never use unspecified tester or other measuring device.

1. CHECK HARNESS CONNECTOR

Check the harness connector.

Is the inspection result normal?

- YES >> GO TO 2.
NO >> Replace harness connector.

2. CHECK WIRING HARNESS

Check the wiring harness externals.

Is the inspection result normal?

- YES >> GO TO 3.
NO >> Replace wiring harness.

3. REPLACE AIR BAG DIAGNOSIS SENSOR UNIT

1. Replace air bag diagnosis sensor unit. Refer to [SR-29, "Removal and Installation"](#).
2. Perform DTC confirmation procedure. Refer to [SRC-78, "DTC Logic"](#).

Is DTC detected?

- YES >> GO TO 4.
NO >> INSPECTION END

4. REPLACE PASSENGER AIR BAG MODULE

1. Replace passenger air bag module. Refer to [SR-18, "Removal and Installation"](#).
2. Perform DTC confirmation procedure. Refer to [SRC-78, "DTC Logic"](#).

Is DTC detected?

- YES >> GO TO 1.

B1067, B1072 PASSENGER AIR BAG MODULE

< DTC/CIRCUIT DIAGNOSIS >

NO >> INSPECTION END

A

B

C

D

E

F

G

SRC

I

J

K

L

M

N

O

P

B1068, B1073 PASSENGER AIR BAG MODULE

< DTC/CIRCUIT DIAGNOSIS >

B1068, B1073 PASSENGER AIR BAG MODULE

DTC Logic

INFOID:000000009649899

DTC DETECTION LOGIC

DTC	Display contents of CONSULT	DTC detecting condition	Possible cause
B1068 B1073	ASSIST A/B MODULE [SHORT]	Passenger air bag module circuits are shorted to each other	<ul style="list-style-type: none">• Disconnection of wiring harness and short• Malfunction in passenger air bag module• Malfunction in air bag diagnosis sensor unit

DTC CONFIRMATION PROCEDURE

1. CHECK SELF-DIAG RESULT

With CONSULT

1. Turn ignition switch ON.
2. Perform "Self Diagnostic Result" mode of "AIR BAG" using CONSULT.

Without CONSULT

1. Turn ignition switch ON.
2. Check the air bag warning lamp status. Refer to [SRC-15, "On Board Diagnosis Function"](#).

NOTE:

SRS does not enter the diagnosis mode if no malfunction is detected in the user mode.

Is malfunctioning part detected?

- YES >> Refer to [SRC-80, "Diagnosis Procedure"](#).
NO >> INSPECTION END

Diagnosis Procedure

INFOID:000000009649900

WARNING:

- Before servicing, turn ignition switch OFF, disconnect battery negative terminal, and wait at least 3 minutes or more. (To discharge backup capacitor.)
- Never use unspecified tester or other measuring device.

1. CHECK HARNESS CONNECTOR

Check the harness connector.

Is the inspection result normal?

- YES >> GO TO 2.
NO >> Replace harness connector.

2. CHECK WIRING HARNESS

Check the wiring harness externals.

Is the inspection result normal?

- YES >> GO TO 3.
NO >> Replace wiring harness.

3. REPLACE AIR BAG DIAGNOSIS SENSOR UNIT

1. Replace air bag diagnosis sensor unit. Refer to [SR-29, "Removal and Installation"](#).
2. Perform DTC confirmation procedure. Refer to [SRC-80, "DTC Logic"](#).

Is DTC detected?

- YES >> GO TO 4.
NO >> INSPECTION END

4. REPLACE PASSENGER AIR BAG MODULE

1. Replace passenger air bag module. Refer to [SR-18, "Removal and Installation"](#).
2. Perform DTC confirmation procedure. Refer to [SRC-80, "DTC Logic"](#).

Is DTC detected?

- YES >> GO TO 1.

B1068, B1073 PASSENGER AIR BAG MODULE

< DTC/CIRCUIT DIAGNOSIS >

NO >> INSPECTION END

A

B

C

D

E

F

G

SRC

I

J

K

L

M

N

O

P

B1074, B1075, B1076, B1077, B1078, B1079 DIAGNOSIS SENSOR UNIT

< DTC/CIRCUIT DIAGNOSIS >

B1074, B1075, B1076, B1077, B1078, B1079 DIAGNOSIS SENSOR UNIT

DTC Logic

INFOID:000000009649901

DTC DETECTION LOGIC

DTC	Display contents of CONSULT	DTC detecting condition	Possible cause
B1074 B1075 B1076 B1077 B1078 B1079	CONTROL UNIT	Air bag diagnosis sensor unit is malfunctioning	Malfunction in air bag diagnosis sensor unit

DTC CONFIRMATION PROCEDURE

1.CHECK SELF-DIAG RESULT

④ With CONSULT

1. Turn ignition switch ON.
2. Perform "Self Diagnostic Result" mode of "AIR BAG" using CONSULT.

④ Without CONSULT

1. Turn ignition switch ON.
2. Check the air bag warning lamp status. Refer to [SRC-15, "On Board Diagnosis Function"](#).

NOTE:

SRS does not enter the diagnosis mode if no malfunction is detected in the user mode.

Is malfunctioning part detected?

- YES >> Refer to [SRC-82, "Diagnosis Procedure"](#).
NO >> INSPECTION END

Diagnosis Procedure

INFOID:000000009649902

WARNING:

- Before servicing, turn ignition switch OFF, disconnect battery negative terminal, and wait at least 3 minutes or more. (To discharge backup capacitor.)
- Never use unspecified tester or other measuring device.

1.CHECK HARNESS CONNECTOR

Check the harness connector.

Is the inspection result normal?

- YES >> GO TO 2.
NO >> Replace harness connectors.

2.CHECK WIRING HARNESS

Check the wiring harness externals.

Is the inspection result normal?

- YES >> GO TO 3.
NO >> Replace wiring harness.

3.REPLACE AIR BAG DIAGNOSIS SENSOR UNIT

1. Replace air bag diagnosis sensor unit. Refer to [SR-29, "Removal and Installation"](#).
2. Perform DTC confirmation procedure. Refer to [SRC-82, "DTC Logic"](#).

Is DTC detected?

- YES >> GO TO 1.
NO >> INSPECTION END

B1080, B1096 DRIVER AIR BAG MODULE

< DTC/CIRCUIT DIAGNOSIS >

B1080, B1096 DRIVER AIR BAG MODULE

DTC Logic

INFOID:000000009649903

DTC DETECTION LOGIC

DTC	Display contents of CONSULT	DTC detecting condition	Possible cause
B1080 B1096	DRIVER AIRBAG MODULE [SHORT]	Driver air bag module circuit are shorted to each other (including the spiral cable)	<ul style="list-style-type: none">• Harness or connectors (The module circuit is shorted.)• Malfunction in driver air bag module• Malfunction in spiral cable• Malfunction in air bag diagnosis sensor unit

DTC CONFIRMATION PROCEDURE

1.CHECK SELF-DIAG RESULT

With CONSULT

1. Turn ignition switch ON.
2. Perform "Self Diagnostic Result" mode of "AIR BAG" using CONSULT.

Without CONSULT

1. Turn ignition switch ON.
2. Check the air bag warning lamp status. Refer to [SRC-15, "On Board Diagnosis Function"](#).

NOTE:

SRS does not enter the diagnosis mode if no malfunction is detected in the user mode.

Is malfunctioning part detected?

- YES >> Refer to [SRC-83, "Diagnosis Procedure"](#).
NO >> INSPECTION END

Diagnosis Procedure

INFOID:000000009649904

WARNING:

- Before servicing, turn ignition switch OFF, disconnect battery negative terminal, and wait at least 3 minutes or more. (To discharge backup capacitor.)
- Never use unspecified tester or other measuring device.

1.CHECK HARNESS CONNECTOR

Check the harness connector.

Is the inspection result normal?

- YES >> GO TO 2.
NO >> Replace harness connector.

2.CHECK WIRING HARNESS

Check the wiring harness externals.

Is the inspection result normal?

- YES >> GO TO 3.
NO >> Replace wiring harness.

3.CHECK SPIRAL CABLE CIRCUIT-I

1. Turn ignition switch OFF.
2. Disconnect driver air bag module harness connector and combination switch (spiral cable) harness connector.
3. Check continuity between combination switch (spiral cable) terminals.

B1080, B1096 DRIVER AIR BAG MODULE

< DTC/CIRCUIT DIAGNOSIS >

Combination switch (spiral cable)				Continuity
Connector	Terminal	Connector	Terminal	
M301	10	M301	11	Not existed
		M300	9	
			12	

Is the inspection result normal?

YES >> GO TO 4.

NO >> Replace combination switch (spiral cable). Refer to [SR-15. "Removal and Installation"](#).

4. CHECK SPIRAL CABLE CIRCUIT-II

Check continuity between combination switch (spiral cable) terminals.

Combination switch (spiral cable)			Continuity
Connector	Terminal	Terminal	
M32	28	29	Not existed
		30	

Is the inspection result normal?

YES >> GO TO 5.

NO >> Replace combination switch (spiral cable). Refer to [SR-15. "Removal and Installation"](#).

5. REPLACE AIR BAG DIAGNOSIS SENSOR UNIT

1. Replace air bag diagnosis sensor unit. Refer to [SR-29. "Removal and Installation"](#).

2. Perform DTC confirmation procedure. Refer to [SRC-83. "DTC Logic"](#).

Is DTC detected?

YES >> GO TO 6.

NO >> INSPECTION END

6. REPLACE DRIVER AIR BAG MODULE

1. Replace driver air bag module. Refer to [SR-12. "Removal and Installation"](#).

2. Perform DTC confirmation procedure. Refer to [SRC-83. "DTC Logic"](#).

Is DTC detected?

YES >> GO TO 1.

NO >> INSPECTION END

B1081 SEAT BELT PRE-TENSIONER RH

< DTC/CIRCUIT DIAGNOSIS >

B1081 SEAT BELT PRE-TENSIONER RH

DTC Logic

INFOID:000000009649905

DTC DETECTION LOGIC

DTC	Display contents of CONSULT	DTC detecting condition	Possible cause
B1081	PRE-TEN FRONT RH [OPEN]	Seat belt pre-tensioner RH circuit is open	<ul style="list-style-type: none">• Disconnection of wiring harness and open• Malfunction in seat belt pre-tensioner RH• Malfunction in air bag diagnosis sensor unit

DTC CONFIRMATION PROCEDURE

1. CHECK SELF-DIAG RESULT

With CONSULT

1. Turn ignition switch ON.
2. Perform "Self Diagnostic Result" mode of "AIR BAG" using CONSULT.

Without CONSULT

1. Turn ignition switch ON.
2. Check the air bag warning lamp status. Refer to [SRC-15, "On Board Diagnosis Function"](#).

NOTE:

SRS does not enter the diagnosis mode if no malfunction is detected in the user mode.

Is malfunctioning part detected?

- YES >> Refer to [SRC-85, "Diagnosis Procedure"](#).
NO >> INSPECTION END

Diagnosis Procedure

INFOID:000000009649906

WARNING:

- Before servicing, turn ignition switch OFF, disconnect battery negative terminal, and wait at least 3 minutes or more. (To discharge backup capacitor.)
- Never use unspecified tester or other measuring device.

1. CHECK HARNESS CONNECTOR

Check the harness connector.

Is the inspection result normal?

- YES >> GO TO 2.
NO >> Replace harness connector.

2. CHECK WIRING HARNESS

Check the wiring harness externals.

Is the inspection result normal?

- YES >> GO TO 3.
NO >> Replace wiring harness.

3. REPLACE SEAT BELT PRE-TENSIONER

1. Replace seat belt pre-tensioner RH. Refer to [SR-31, "Removal and Installation"](#).
2. Perform DTC confirmation procedure. Refer to [SRC-85, "DTC Logic"](#).

Is DTC detected?

- YES >> GO TO 4.
NO >> INSPECTION END

4. REPLACE AIR BAG DIAGNOSIS SENSOR UNIT

1. Replace air bag diagnosis sensor unit. Refer to [SR-29, "Removal and Installation"](#).
2. Perform DTC confirmation procedure. Refer to [SRC-85, "DTC Logic"](#).

Is DTC detected?

- YES >> GO TO 1.

B1081 SEAT BELT PRE-TENSIONER RH

< DTC/CIRCUIT DIAGNOSIS >

NO >> INSPECTION END

B1082 SEAT BELT PRE-TENSIONER RH

< DTC/CIRCUIT DIAGNOSIS >

B1082 SEAT BELT PRE-TENSIONER RH

DTC Logic

INFOID:000000009649907

DTC DETECTION LOGIC

DTC	Display contents of CONSULT	DTC detecting condition	Possible cause
B1082	PRE-TEN FRONT RH [VB-SHORT]	Seat belt pre-tensioner RH circuit is shorted to power supply circuit	<ul style="list-style-type: none">• Disconnection of wiring harness and short• Malfunction in seat belt pre-tensioner RH• Malfunction in air bag diagnosis sensor unit

DTC CONFIRMATION PROCEDURE

1.CHECK SELF-DIAG RESULT

With CONSULT

1. Turn ignition switch ON.
2. Perform "Self Diagnostic Result" mode of "AIR BAG" using CONSULT.

Without CONSULT

1. Turn ignition switch ON.
2. Check the air bag warning lamp status. Refer to [SRC-15, "On Board Diagnosis Function"](#).

NOTE:

SRS does not enter the diagnosis mode if no malfunction is detected in the user mode.

Is malfunctioning part detected?

- YES >> Refer to [SRC-87, "Diagnosis Procedure"](#).
NO >> INSPECTION END

Diagnosis Procedure

INFOID:000000009649908

WARNING:

- Before servicing, turn ignition switch OFF, disconnect battery negative terminal, and wait at least 3 minutes or more. (To discharge backup capacitor.)
- Never use unspecified tester or other measuring device.

1.CHECK HARNESS CONNECTOR

Check the harness connector.

Is the inspection result normal?

- YES >> GO TO 2.
NO >> Replace harness connector.

2.CHECK WIRING HARNESS

Check the wiring harness externals.

Is the inspection result normal?

- YES >> GO TO 3.
NO >> Replace wiring harness.

3.REPLACE SEAT BELT PRE-TENSIONER

1. Replace seat belt pre-tensioner RH. Refer to [SR-31, "Removal and Installation"](#).
2. Perform DTC confirmation procedure. Refer to [SRC-87, "DTC Logic"](#).

Is DTC detected?

- YES >> GO TO 4.
NO >> INSPECTION END

4.REPLACE AIR BAG DIAGNOSIS SENSOR UNIT

1. Replace air bag diagnosis sensor unit. Refer to [SR-29, "Removal and Installation"](#).
2. Perform DTC confirmation procedure. Refer to [SRC-87, "DTC Logic"](#).

Is DTC detected?

- YES >> GO TO 1.

B1082 SEAT BELT PRE-TENSIONER RH

< DTC/CIRCUIT DIAGNOSIS >

NO >> INSPECTION END

B1083 SEAT BELT PRE-TENSIONER RH

< DTC/CIRCUIT DIAGNOSIS >

B1083 SEAT BELT PRE-TENSIONER RH

DTC Logic

INFOID:000000009649909

DTC DETECTION LOGIC

DTC	Display contents of CONSULT	DTC detecting condition	Possible cause
B1083	PRE-TEN FRONT RH [GND-SHORT]	Seat belt pre-tensioner RH circuit is shorted to ground	<ul style="list-style-type: none"> • Disconnection of wiring harness and short • Malfunction in seat belt pre-tensioner RH • Malfunction in air bag diagnosis sensor unit

DTC CONFIRMATION PROCEDURE

1. CHECK SELF-DIAG RESULT

With CONSULT

1. Turn ignition switch ON.
2. Perform "Self Diagnostic Result" mode of "AIR BAG" using CONSULT.

Without CONSULT

1. Turn ignition switch ON.
2. Check the air bag warning lamp status. Refer to [SRC-15, "On Board Diagnosis Function"](#).

NOTE:

SRS does not enter the diagnosis mode if no malfunction is detected in the user mode.

Is malfunctioning part detected?

- YES >> Refer to [SRC-89, "Diagnosis Procedure"](#).
 NO >> INSPECTION END

Diagnosis Procedure

INFOID:000000009649910

WARNING:

- Before servicing, turn ignition switch OFF, disconnect battery negative terminal, and wait at least 3 minutes or more. (To discharge backup capacitor.)
- Never use unspecified tester or other measuring device.

1. CHECK HARNESS CONNECTOR

Check the harness connector.

Is the inspection result normal?

- YES >> GO TO 2.
 NO >> Replace harness connector.

2. CHECK WIRING HARNESS

Check the wiring harness externals.

Is the inspection result normal?

- YES >> GO TO 3.
 NO >> Replace wiring harness.

3. REPLACE SEAT BELT PRE-TENSIONER

1. Replace seat belt pre-tensioner RH. Refer to [SR-31, "Removal and Installation"](#).
2. Perform DTC confirmation procedure. Refer to [SRC-89, "DTC Logic"](#).

Is DTC detected?

- YES >> GO TO 4.
 NO >> INSPECTION END

4. REPLACE AIR BAG DIAGNOSIS SENSOR UNIT

1. Replace air bag diagnosis sensor unit. Refer to [SR-29, "Removal and Installation"](#).
2. Perform DTC confirmation procedure. Refer to [SRC-89, "DTC Logic"](#).

Is DTC detected?

- YES >> GO TO 1.

B1083 SEAT BELT PRE-TENSIONER RH

< DTC/CIRCUIT DIAGNOSIS >

NO >> INSPECTION END

B1084 SEAT BELT PRE-TENSIONER RH

< DTC/CIRCUIT DIAGNOSIS >

B1084 SEAT BELT PRE-TENSIONER RH

DTC Logic

INFOID:000000009649911

DTC DETECTION LOGIC

DTC	Display contents of CONSULT	DTC detecting condition	Possible cause
B1084	PRE-TEN FRONT RH [SHORT]	Seat belt pre-tensioner RH circuits are shorted to each other	<ul style="list-style-type: none">• Disconnection of wiring harness and short• Malfunction in seat belt pre-tensioner RH• Malfunction in air bag diagnosis sensor unit

DTC CONFIRMATION PROCEDURE

1. CHECK SELF-DIAG RESULT

With CONSULT

1. Turn ignition switch ON.
2. Perform "Self Diagnostic Result" mode of "AIR BAG" using CONSULT.

Without CONSULT

1. Turn ignition switch ON.
2. Check the air bag warning lamp status. Refer to [SRC-15, "On Board Diagnosis Function"](#).

NOTE:

SRS does not enter the diagnosis mode if no malfunction is detected in the user mode.

Is malfunctioning part detected?

- YES >> Refer to [SRC-91, "Diagnosis Procedure"](#).
NO >> INSPECTION END

Diagnosis Procedure

INFOID:000000009649912

WARNING:

- Before servicing, turn ignition switch OFF, disconnect battery negative terminal, and wait at least 3 minutes or more. (To discharge backup capacitor.)
- Never use unspecified tester or other measuring device.

1. CHECK HARNESS CONNECTOR

Check the harness connector.

Is the inspection result normal?

- YES >> GO TO 2.
NO >> Replace harness connector.

2. CHECK WIRING HARNESS

Check the wiring harness externals.

Is the inspection result normal?

- YES >> GO TO 3.
NO >> Replace wiring harness.

3. REPLACE SEAT BELT PRE-TENSIONER

1. Replace seat belt pre-tensioner RH. Refer to [SR-31, "Removal and Installation"](#).
2. Perform DTC confirmation procedure. Refer to [SRC-91, "DTC Logic"](#).

Is DTC detected?

- YES >> GO TO 4.
NO >> INSPECTION END

4. REPLACE AIR BAG DIAGNOSIS SENSOR UNIT

1. Replace air bag diagnosis sensor unit. Refer to [SR-29, "Removal and Installation"](#).
2. Perform DTC confirmation procedure. Refer to [SRC-91, "DTC Logic"](#).

Is DTC detected?

- YES >> GO TO 1.

B1084 SEAT BELT PRE-TENSIONER RH

< DTC/CIRCUIT DIAGNOSIS >

NO >> INSPECTION END

B1086 SEAT BELT PRE-TENSIONER LH

< DTC/CIRCUIT DIAGNOSIS >

B1086 SEAT BELT PRE-TENSIONER LH

DTC Logic

INFOID:000000009649913

DTC DETECTION LOGIC

DTC	Display contents of CONSULT	DTC detecting condition	Possible cause
B1086	PRE-TEN FRONT LH [OPEN]	Seat belt pre-tensioner LH circuit is open	<ul style="list-style-type: none">• Disconnection of wiring harness and open• Malfunction in seat belt pre-tensioner LH• Malfunction in air bag diagnosis sensor unit

DTC CONFIRMATION PROCEDURE

1. CHECK SELF-DIAG RESULT

With CONSULT

1. Turn ignition switch ON.
2. Perform "Self Diagnostic Result" mode of "AIR BAG" using CONSULT.

Without CONSULT

1. Turn ignition switch ON.
2. Check the air bag warning lamp status. Refer to [SRC-15, "On Board Diagnosis Function"](#).

NOTE:

SRS does not enter the diagnosis mode if no malfunction is detected in the user mode.

Is malfunctioning part detected?

- YES >> Refer to [SRC-93, "Diagnosis Procedure"](#).
NO >> INSPECTION END

Diagnosis Procedure

INFOID:000000009649914

WARNING:

- Before servicing, turn ignition switch OFF, disconnect battery negative terminal, and wait at least 3 minutes or more. (To discharge backup capacitor.)
- Never use unspecified tester or other measuring device.

1. CHECK HARNESS CONNECTOR

Check the harness connector.

Is the inspection result normal?

- YES >> GO TO 2.
NO >> Replace harness connector.

2. CHECK WIRING HARNESS

Check the wiring harness externals.

Is the inspection result normal?

- YES >> GO TO 3.
NO >> Replace wiring harness.

3. REPLACE SEAT BELT PRE-TENSIONER

1. Replace seat belt pre-tensioner LH. Refer to [SR-31, "Removal and Installation"](#).
2. Perform DTC confirmation procedure. Refer to [SRC-93, "DTC Logic"](#).

Is DTC detected?

- YES >> GO TO 4.
NO >> INSPECTION END

4. REPLACE AIR BAG DIAGNOSIS SENSOR UNIT

1. Replace air bag diagnosis sensor unit. Refer to [SR-29, "Removal and Installation"](#).
2. Perform DTC confirmation procedure. Refer to [SRC-93, "DTC Logic"](#).

Is DTC detected?

- YES >> GO TO 1.

B1086 SEAT BELT PRE-TENSIONER LH

< DTC/CIRCUIT DIAGNOSIS >

NO >> INSPECTION END

B1087 SEAT BELT PRE-TENSIONER LH

< DTC/CIRCUIT DIAGNOSIS >

B1087 SEAT BELT PRE-TENSIONER LH

DTC Logic

INFOID:000000009649915

DTC DETECTION LOGIC

DTC	Display contents of CONSULT	DTC detecting condition	Possible cause
B1087	PRE-TEN FRONT LH [VB-SHORT]	Seat belt pre-tensioner LH circuit is shorted to power supply circuit	<ul style="list-style-type: none">• Disconnection of wiring harness and short• Malfunction in seat belt pre-tensioner LH• Malfunction in air bag diagnosis sensor unit

DTC CONFIRMATION PROCEDURE

1. CHECK SELF-DIAG RESULT

With CONSULT

1. Turn ignition switch ON.
2. Perform "Self Diagnostic Result" mode of "AIR BAG" using CONSULT.

Without CONSULT

1. Turn ignition switch ON.
2. Check the air bag warning lamp status. Refer to [SRC-15, "On Board Diagnosis Function"](#).

NOTE:

SRS does not enter the diagnosis mode if no malfunction is detected in the user mode.

Is malfunctioning part detected?

- YES >> Refer to [SRC-95, "Diagnosis Procedure"](#).
NO >> INSPECTION END

Diagnosis Procedure

INFOID:000000009649916

WARNING:

- Before servicing, turn ignition switch OFF, disconnect battery negative terminal, and wait at least 3 minutes or more. (To discharge backup capacitor.)
- Never use unspecified tester or other measuring device.

1. CHECK HARNESS CONNECTOR

Check the harness connector.

Is the inspection result normal?

- YES >> GO TO 2.
NO >> Replace harness connector.

2. CHECK WIRING HARNESS

Check the wiring harness externals.

Is the inspection result normal?

- YES >> GO TO 3.
NO >> Replace wiring harness.

3. REPLACE SEAT BELT PRE-TENSIONER

1. Replace seat belt pre-tensioner LH. Refer to [SR-31, "Removal and Installation"](#).
2. Perform DTC confirmation procedure. Refer to [SRC-95, "DTC Logic"](#).

Is DTC detected?

- YES >> GO TO 4.
NO >> INSPECTION END

4. REPLACE AIR BAG DIAGNOSIS SENSOR UNIT

1. Replace air bag diagnosis sensor unit. Refer to [SR-29, "Removal and Installation"](#).
2. Perform DTC confirmation procedure. Refer to [SRC-95, "DTC Logic"](#).

Is DTC detected?

- YES >> GO TO 1.

B1087 SEAT BELT PRE-TENSIONER LH

< DTC/CIRCUIT DIAGNOSIS >

NO >> INSPECTION END

B1088 SEAT BELT PRE-TENSIONER LH

< DTC/CIRCUIT DIAGNOSIS >

B1088 SEAT BELT PRE-TENSIONER LH

DTC Logic

INFOID:000000009649917

DTC DETECTION LOGIC

DTC	Display contents of CONSULT	DTC detecting condition	Possible cause
B1088	PRE-TEN FRONT LH [GND-SHORT]	Seat belt pre-tensioner LH circuit is shorted to ground	<ul style="list-style-type: none">• Disconnection of wiring harness and short• Malfunction in seat belt pre-tensioner LH• Malfunction in air bag diagnosis sensor unit

DTC CONFIRMATION PROCEDURE

1. CHECK SELF-DIAG RESULT

With CONSULT

1. Turn ignition switch ON.
2. Perform "Self Diagnostic Result" mode of "AIR BAG" using CONSULT.

Without CONSULT

1. Turn ignition switch ON.
2. Check the air bag warning lamp status. Refer to [SRC-15, "On Board Diagnosis Function"](#).

NOTE:

SRS does not enter the diagnosis mode if no malfunction is detected in the user mode.

Is malfunctioning part detected?

- YES >> Refer to [SRC-97, "Diagnosis Procedure"](#).
NO >> INSPECTION END

Diagnosis Procedure

INFOID:000000009649918

WARNING:

- Before servicing, turn ignition switch OFF, disconnect battery negative terminal, and wait at least 3 minutes or more. (To discharge backup capacitor.)
- Never use unspecified tester or other measuring device.

1. CHECK HARNESS CONNECTOR

Check the harness connector.

Is the inspection result normal?

- YES >> GO TO 2.
NO >> Replace harness connector.

2. CHECK WIRING HARNESS

Check the wiring harness externals.

Is the inspection result normal?

- YES >> GO TO 3.
NO >> Replace wiring harness.

3. REPLACE SEAT BELT PRE-TENSIONER

1. Replace seat belt pre-tensioner LH. Refer to [SR-31, "Removal and Installation"](#).
2. Perform DTC confirmation procedure. Refer to [SRC-97, "DTC Logic"](#).

Is DTC detected?

- YES >> GO TO 4.
NO >> INSPECTION END

4. REPLACE AIR BAG DIAGNOSIS SENSOR UNIT

1. Replace air bag diagnosis sensor unit. Refer to [SR-29, "Removal and Installation"](#).
2. Perform DTC confirmation procedure. Refer to [SRC-97, "DTC Logic"](#).

Is DTC detected?

- YES >> GO TO 1.

B1088 SEAT BELT PRE-TENSIONER LH

< DTC/CIRCUIT DIAGNOSIS >

NO >> INSPECTION END

B1089 SEAT BELT PRE-TENSIONER LH

< DTC/CIRCUIT DIAGNOSIS >

B1089 SEAT BELT PRE-TENSIONER LH

DTC Logic

INFOID:000000009649919

DTC DETECTION LOGIC

DTC	Display contents of CONSULT	DTC detecting condition	Possible cause
B1089	PRE-TEN FRONT LH [SHORT]	Seat belt pre-tensioner LH circuits are shorted to each other	<ul style="list-style-type: none">• Disconnection of wiring harness and short• Malfunction in seat belt pre-tensioner LH• Malfunction in air bag diagnosis sensor unit

DTC CONFIRMATION PROCEDURE

1. CHECK SELF-DIAG RESULT

With CONSULT

1. Turn ignition switch ON.
2. Perform "Self Diagnostic Result" mode of "AIR BAG" using CONSULT.

Without CONSULT

1. Turn ignition switch ON.
2. Check the air bag warning lamp status. Refer to [SRC-15, "On Board Diagnosis Function"](#).

NOTE:

SRS does not enter the diagnosis mode if no malfunction is detected in the user mode.

Is malfunctioning part detected?

- YES >> Refer to [SRC-99, "Diagnosis Procedure"](#).
NO >> INSPECTION END

Diagnosis Procedure

INFOID:000000009649920

WARNING:

- Before servicing, turn ignition switch OFF, disconnect battery negative terminal, and wait at least 3 minutes or more. (To discharge backup capacitor.)
- Never use unspecified tester or other measuring device.

1. CHECK HARNESS CONNECTOR

Check the harness connector.

Is the inspection result normal?

- YES >> GO TO 2.
NO >> Replace harness connector.

2. CHECK WIRING HARNESS

Check the wiring harness externals.

Is the inspection result normal?

- YES >> GO TO 3.
NO >> Replace wiring harness.

3. REPLACE SEAT BELT PRE-TENSIONER

1. Replace seat belt pre-tensioner LH. Refer to [SR-31, "Removal and Installation"](#).
2. Perform DTC confirmation procedure. Refer to [SRC-99, "DTC Logic"](#).

Is DTC detected?

- YES >> GO TO 4.
NO >> INSPECTION END

4. REPLACE AIR BAG DIAGNOSIS SENSOR UNIT

1. Replace air bag diagnosis sensor unit. Refer to [SR-29, "Removal and Installation"](#).
2. Perform DTC confirmation procedure. Refer to [SRC-99, "DTC Logic"](#).

Is DTC detected?

- YES >> GO TO 1.

B1089 SEAT BELT PRE-TENSIONER LH

< DTC/CIRCUIT DIAGNOSIS >

NO >> INSPECTION END

B1090, B1091, B1092, B1093, B1094, B1095 DIAGNOSIS SENSOR UNIT

< DTC/CIRCUIT DIAGNOSIS >

B1090, B1091, B1092, B1093, B1094, B1095 DIAGNOSIS SENSOR UNIT

DTC Logic

INFOID:000000009649921

DTC DETECTION LOGIC

DTC	Display contents of CONSULT	DTC detecting condition	Possible cause
B1090 B1091 B1092 B1093 B0194 B1095	CONTROL UNIT	Air bag diagnosis sensor unit is malfunctioning	Malfunction in air bag diagnosis sensor unit

DTC CONFIRMATION PROCEDURE

1. CHECK SELF-DIAG RESULT

With CONSULT

1. Turn ignition switch ON.
2. Perform "Self Diagnostic Result" mode of "AIR BAG" using CONSULT.

Without CONSULT

1. Turn ignition switch ON.
2. Check the air bag warning lamp status. Refer to [SRC-15, "On Board Diagnosis Function"](#).

NOTE:

SRS does not enter the diagnosis mode if no malfunction is detected in the user mode.

Is malfunctioning part detected?

- YES >> Refer to [SRC-101, "Diagnosis Procedure"](#).
NO >> INSPECTION END

Diagnosis Procedure

INFOID:000000009649922

WARNING:

- Before servicing, turn ignition switch OFF, disconnect battery negative terminal, and wait at least 3 minutes or more. (To discharge backup capacitor.)
- Never use unspecified tester or other measuring device.

1. CHECK HARNESS CONNECTOR

Check the harness connector.

Is the inspection result normal?

- YES >> GO TO 2.
NO >> Replace harness connectors.

2. CHECK WIRING HARNESS

Check the wiring harness externals.

Is the inspection result normal?

- YES >> GO TO 3.
NO >> Replace wiring harness.

3. REPLACE AIR BAG DIAGNOSIS SENSOR UNIT

1. Replace air bag diagnosis sensor unit. Refer to [SR-29, "Removal and Installation"](#).
2. Perform DTC confirmation procedure. Refer to [SRC-101, "DTC Logic"](#).

Is DTC detected?

- YES >> GO TO 1.
NO >> INSPECTION END

B1106, B1107, B1108, B1109, B1110, B1111 DIAGNOSIS SENSOR UNIT

< DTC/CIRCUIT DIAGNOSIS >

B1106, B1107, B1108, B1109, B1110, B1111 DIAGNOSIS SENSOR UNIT

DTC Logic

INFOID:000000009649923

DTC DETECTION LOGIC

DTC	Display contents of CONSULT	DTC detecting condition	Possible cause
B1106 B1107 B1108 B1109 B1110 B1111	CONTROL UNIT	Air bag diagnosis sensor unit is malfunctioning	Malfunction in air bag diagnosis sensor unit

DTC CONFIRMATION PROCEDURE

1. CHECK SELF-DIAG RESULT

With CONSULT

1. Turn ignition switch ON.
2. Perform "Self Diagnostic Result" mode of "AIR BAG" using CONSULT.

Without CONSULT

1. Turn ignition switch ON.
2. Check the air bag warning lamp status. Refer to [SRC-15, "On Board Diagnosis Function"](#).

NOTE:

SRS does not enter the diagnosis mode if no malfunction is detected in the user mode.

Is malfunctioning part detected?

- YES >> Refer to [SRC-102, "Diagnosis Procedure"](#).
NO >> INSPECTION END

Diagnosis Procedure

INFOID:000000009649924

WARNING:

- Before servicing, turn ignition switch OFF, disconnect battery negative terminal, and wait at least 3 minutes or more. (To discharge backup capacitor.)
- Never use unspecified tester or other measuring device.

1. CHECK HARNESS CONNECTOR

Check the harness connector.

Is the inspection result normal?

- YES >> GO TO 2.
NO >> Replace harness connectors.

2. CHECK WIRING HARNESS

Check the wiring harness externals.

Is the inspection result normal?

- YES >> GO TO 3.
NO >> Replace wiring harness.

3. REPLACE AIR BAG DIAGNOSIS SENSOR UNIT

1. Replace air bag diagnosis sensor unit. Refer to [SR-29, "Removal and Installation"](#).
2. Perform DTC confirmation procedure. Refer to [SRC-102, "DTC Logic"](#).

Is DTC detected?

- YES >> GO TO 1.
NO >> INSPECTION END

B1113, B1114 SATELLITE SENSOR RH

< DTC/CIRCUIT DIAGNOSIS >

B1113, B1114 SATELLITE SENSOR RH

DTC Logic

INFOID:000000009649925

DTC DETECTION LOGIC

DTC	Display contents of CONSULT	DTC detecting condition	Possible cause
B1113 B1114	SATELLITE SENS RH [UNIT FAIL]	Front satellite sensor RH is malfunctioning	<ul style="list-style-type: none">• Disconnection of wiring harness• Malfunction in front satellite sensor RH• Malfunction in air bag diagnosis sensor unit

DTC CONFIRMATION PROCEDURE

1. CHECK SELF-DIAG RESULT

With CONSULT

1. Turn ignition switch ON.
2. Perform "Self Diagnostic Result" mode of "AIR BAG" using CONSULT.

Without CONSULT

1. Turn ignition switch ON.
2. Check the air bag warning lamp status. Refer to [SRC-15, "On Board Diagnosis Function"](#).

NOTE:

SRS does not enter the diagnosis mode if no malfunction is detected in the user mode.

Is malfunctioning part detected?

- YES >> Refer to [SRC-103, "Diagnosis Procedure"](#).
NO >> INSPECTION END

Diagnosis Procedure

INFOID:000000009649926

WARNING:

- Before servicing, turn ignition switch OFF, disconnect battery negative terminal, and wait at least 3 minutes or more. (To discharge backup capacitor.)
- Never use unspecified tester or other measuring device.

1. CHECK HARNESS CONNECTOR

Check the harness connector.

Is the inspection result normal?

- YES >> GO TO 2.
NO >> Replace harness connector.

2. CHECK WIRING HARNESS

Check the wiring harness externals.

Is the inspection result normal?

- YES >> GO TO 3.
NO >> Replace wiring harness.

3. REPLACE FRONT SATELLITE SENSOR

1. Replace front satellite sensor RH. Refer to [SR-31, "Removal and Installation"](#).
2. Perform DTC confirmation procedure. Refer to [SRC-103, "DTC Logic"](#).

Is DTC detected?

- YES >> GO TO 4.
NO >> INSPECTION END

4. REPLACE AIR BAG DIAGNOSIS SENSOR UNIT

1. Replace air bag diagnosis sensor unit. Refer to [SR-29, "Removal and Installation"](#).
2. Perform DTC confirmation procedure. Refer to [SRC-103, "DTC Logic"](#).

Is DTC detected?

- YES >> GO TO 1.

B1113, B1114 SATELLITE SENSOR RH

< DTC/CIRCUIT DIAGNOSIS >

NO >> INSPECTION END

B1115 SATELLITE SENSOR RH

< DTC/CIRCUIT DIAGNOSIS >

B1115 SATELLITE SENSOR RH

DTC Logic

INFOID:000000009649927

DTC DETECTION LOGIC

DTC	Display contents of CONSULT	DTC detecting condition	Possible cause
B1115	SATELLITE SENS RH [COMM FAIL]	Front satellite sensor RH is malfunctioning or out of the specified specification	<ul style="list-style-type: none">• Disconnection of wiring harness• Malfunction in front satellite sensor RH• Malfunction in air bag diagnosis sensor unit

DTC CONFIRMATION PROCEDURE

1. CHECK SELF-DIAG RESULT

With CONSULT

1. Turn ignition switch ON.
2. Perform "Self Diagnostic Result" mode of "AIR BAG" using CONSULT.

Without CONSULT

1. Turn ignition switch ON.
2. Check the air bag warning lamp status. Refer to [SRC-15, "On Board Diagnosis Function"](#).

NOTE:

SRS does not enter the diagnosis mode if no malfunction is detected in the user mode.

Is malfunctioning part detected?

- YES >> Refer to [SRC-105, "Diagnosis Procedure"](#).
NO >> INSPECTION END

Diagnosis Procedure

INFOID:000000009649928

WARNING:

- Before servicing, turn ignition switch OFF, disconnect battery negative terminal, and wait at least 3 minutes or more. (To discharge backup capacitor.)
- Never use unspecified tester or other measuring device.

1. CHECK HARNESS CONNECTOR

Check the harness connector.

Is the inspection result normal?

- YES >> GO TO 2.
NO >> Replace harness connector.

2. CHECK WIRING HARNESS

Check the wiring harness externals.

Is the inspection result normal?

- YES >> GO TO 3.
NO >> Replace wiring harness.

3. REPLACE FRONT SATELLITE SENSOR

1. Replace front satellite sensor RH. Refer to [SR-26, "Removal and Installation"](#).
2. Perform DTC confirmation procedure. Refer to [SRC-105, "DTC Logic"](#).

Is DTC detected?

- YES >> GO TO 4.
NO >> INSPECTION END

4. REPLACE AIR BAG DIAGNOSIS SENSOR UNIT

1. Replace air bag diagnosis sensor unit. Refer to [SR-29, "Removal and Installation"](#).
2. Perform DTC confirmation procedure. Refer to [SRC-105, "DTC Logic"](#).

Is DTC detected?

- YES >> GO TO 1.

B1115 SATELLITE SENSOR RH

< DTC/CIRCUIT DIAGNOSIS >

NO >> INSPECTION END

B1116 SATELLITE SENSOR RH

< DTC/CIRCUIT DIAGNOSIS >

B1116 SATELLITE SENSOR RH

DTC Logic

INFOID:000000009649929

DTC DETECTION LOGIC

DTC	Display contents of CONSULT	DTC detecting condition	Possible cause
B1116	SATELLITE SENS RH [UNMATCH]	Front satellite sensor RH is out of the specified specification	Diagnosis sensor unit or front satellite sensor RH is different from the part specified

DTC CONFIRMATION PROCEDURE

1. CHECK SELF-DIAG RESULT

With CONSULT

1. Turn ignition switch ON.
2. Perform "Self Diagnostic Result" mode of "AIR BAG" using CONSULT.

Without CONSULT

1. Turn ignition switch ON.
2. Check the air bag warning lamp status. Refer to [SRC-15, "On Board Diagnosis Function"](#).

NOTE:

SRS does not enter the diagnosis mode if no malfunction is detected in the user mode.

Is malfunctioning part detected?

- YES >> Refer to [SRC-107, "Diagnosis Procedure"](#).
NO >> INSPECTION END

Diagnosis Procedure

INFOID:000000009649930

WARNING:

- Before servicing, turn ignition switch OFF, disconnect battery negative terminal, and wait at least 3 minutes or more. (To discharge backup capacitor.)
- Never use unspecified tester or other measuring device.

1. REPLACE FRONT SATELLITE SENSOR

1. Replace front satellite sensor RH. Refer to [SR-26, "Removal and Installation"](#).
2. Perform DTC confirmation procedure. Refer to [SRC-107, "DTC Logic"](#).

Is DTC detected?

- YES >> GO TO 2.
NO >> INSPECTION END

2. REPLACE AIR BAG DIAGNOSIS SENSOR UNIT

1. Replace air bag diagnosis sensor unit. Refer to [SR-29, "Removal and Installation"](#).
2. Perform DTC confirmation procedure. Refer to [SRC-107, "DTC Logic"](#).

Is DTC detected?

- YES >> GO TO 1.
NO >> INSPECTION END

B1118, B1119 SATELLITE SENSOR LH

< DTC/CIRCUIT DIAGNOSIS >

B1118, B1119 SATELLITE SENSOR LH

DTC Logic

INFOID:000000009649931

DTC DETECTION LOGIC

DTC	Display contents of CONSULT	DTC detecting condition	Possible cause
B1118 B1119	SATELLITE SENS LH [UNIT FAIL]	Front satellite sensor LH is malfunctioning	<ul style="list-style-type: none">• Disconnection of wiring harness• Malfunction in front satellite sensor LH• Malfunction in air bag diagnosis sensor unit

DTC CONFIRMATION PROCEDURE

1. CHECK SELF-DIAG RESULT

With CONSULT

1. Turn ignition switch ON.
2. Perform "Self Diagnostic Result" mode of "AIR BAG" using CONSULT.

Without CONSULT

1. Turn ignition switch ON.
2. Check the air bag warning lamp status. Refer to [SRC-15, "On Board Diagnosis Function"](#).

NOTE:

SRS does not enter the diagnosis mode if no malfunction is detected in the user mode.

Is malfunctioning part detected?

- YES >> Refer to [SRC-108, "Diagnosis Procedure"](#).
NO >> INSPECTION END

Diagnosis Procedure

INFOID:000000009649932

WARNING:

- Before servicing, turn ignition switch OFF, disconnect battery negative terminal, and wait at least 3 minutes or more. (To discharge backup capacitor.)
- Never use unspecified tester or other measuring device.

1. CHECK HARNESS CONNECTOR

Check the harness connector.

Is the inspection result normal?

- YES >> GO TO 2.
NO >> Replace harness connector.

2. CHECK WIRING HARNESS

Check the wiring harness externals.

Is the inspection result normal?

- YES >> GO TO 3.
NO >> Replace wiring harness.

3. REPLACE FRONT SATELLITE SENSOR

1. Replace front satellite sensor LH. Refer to [SR-26, "Removal and Installation"](#).
2. Perform DTC confirmation procedure. Refer to [SRC-108, "DTC Logic"](#)

Is DTC detected?

- YES >> GO TO 4.
NO >> INSPECTION END

4. REPLACE AIR BAG DIAGNOSIS SENSOR UNIT

1. Replace air bag diagnosis sensor unit. Refer to [SR-29, "Removal and Installation"](#).
2. Perform DTC confirmation procedure. Refer to [SRC-108, "DTC Logic"](#).

Is DTC detected?

- YES >> GO TO 1.

B1118, B1119 SATELLITE SENSOR LH

< DTC/CIRCUIT DIAGNOSIS >

NO >> INSPECTION END

A

B

C

D

E

F

G

SRC

I

J

K

L

M

N

O

P

B1120 SATELLITE SENSOR LH

< DTC/CIRCUIT DIAGNOSIS >

B1120 SATELLITE SENSOR LH

DTC Logic

INFOID:000000009649933

DTC DETECTION LOGIC

DTC	Display contents of CONSULT	DTC detecting condition	Possible cause
B1120	SATELLITE SENS LH [COMM FAIL]	Front satellite sensor LH is malfunctioning or out of the specified specification	<ul style="list-style-type: none">• Disconnection of wiring harness• Malfunction in front satellite sensor LH• Malfunction in air bag diagnosis sensor unit

DTC CONFIRMATION PROCEDURE

1. CHECK SELF-DIAG RESULT

Ⓟ With CONSULT

1. Turn ignition switch ON.
2. Perform "Self Diagnostic Result" mode of "AIR BAG" using CONSULT.

ⓧ Without CONSULT

1. Turn ignition switch ON.
2. Check the air bag warning lamp status. Refer to [SRC-15, "On Board Diagnosis Function"](#).

NOTE:

SRS does not enter the diagnosis mode if no malfunction is detected in the user mode.

Is malfunctioning part detected?

- YES >> Refer to [SRC-110, "Diagnosis Procedure"](#).
NO >> INSPECTION END

Diagnosis Procedure

INFOID:000000009649934

WARNING:

- Before servicing, turn ignition switch OFF, disconnect battery negative terminal, and wait at least 3 minutes or more. (To discharge backup capacitor.)
- Never use unspecified tester or other measuring device.

1. CHECK HARNESS CONNECTOR

Check the harness connector.

Is the inspection result normal?

- YES >> GO TO 2.
NO >> Replace harness connector.

2. CHECK WIRING HARNESS

Check the wiring harness externals.

Is the inspection result normal?

- YES >> GO TO 3.
NO >> Replace wiring harness.

3. REPLACE FRONT SATELLITE SENSOR

1. Replace front satellite sensor LH. Refer to [SR-26, "Removal and Installation"](#).
2. Perform DTC confirmation procedure. Refer to [SRC-110, "DTC Logic"](#).

Is DTC detected?

- YES >> GO TO 4.
NO >> INSPECTION END

4. REPLACE AIR BAG DIAGNOSIS SENSOR UNIT

1. Replace air bag diagnosis sensor unit. Refer to [SR-29, "Removal and Installation"](#).
2. Perform DTC confirmation procedure. Refer to [SRC-110, "DTC Logic"](#).

Is DTC detected?

- YES >> GO TO 1.

B1120 SATELLITE SENSOR LH

< DTC/CIRCUIT DIAGNOSIS >

NO >> INSPECTION END

A

B

C

D

E

F

G

SRC

I

J

K

L

M

N

O

P

B1121 SATELLITE SENSOR LH

< DTC/CIRCUIT DIAGNOSIS >

B1121 SATELLITE SENSOR LH

DTC Logic

INFOID:000000009649935

DTC DETECTION LOGIC

DTC	Display contents of CONSULT	DTC detecting condition	Possible cause
B1121	SATELLITE SENS LH [UNMATCH]	Front satellite sensor LH is out of the specified specification	Diagnosis front sensor unit or satellite sensor RH is different from the part specified

DTC CONFIRMATION PROCEDURE

1. CHECK SELF-DIAG RESULT

With CONSULT

1. Turn ignition switch ON.
2. Perform "Self Diagnostic Result" mode of "AIR BAG" using CONSULT.

Without CONSULT

1. Turn ignition switch ON.
2. Check the air bag warning lamp status. Refer to [SRC-15, "On Board Diagnosis Function"](#).

NOTE:

SRS does not enter the diagnosis mode if no malfunction is detected in the user mode.

Is malfunctioning part detected?

- YES >> Refer to [SRC-112, "Diagnosis Procedure"](#).
NO >> INSPECTION END

Diagnosis Procedure

INFOID:000000009649936

WARNING:

- Before servicing, turn ignition switch OFF, disconnect battery negative terminal, and wait at least 3 minutes or more. (To discharge backup capacitor.)
- Never use unspecified tester or other measuring device.

1. REPLACE FRONT SATELLITE SENSOR

1. Replace front satellite sensor LH. Refer to [SR-26, "Removal and Installation"](#).
2. Perform DTC confirmation procedure. Refer to [SRC-112, "DTC Logic"](#).

Is DTC detected?

- YES >> GO TO 2.
NO >> INSPECTION END

2. REPLACE AIR BAG DIAGNOSIS SENSOR UNIT

1. Replace air bag diagnosis sensor unit. Refer to [SR-29, "Removal and Installation"](#).
2. Perform DTC confirmation procedure. Refer to [SRC-112, "DTC Logic"](#).

Is DTC detected?

- YES >> GO TO 1.
NO >> INSPECTION END

B1122, B1123, B1124, B1125, B1126, B1127 DIAGNOSIS SENSOR UNIT

< DTC/CIRCUIT DIAGNOSIS >

B1122, B1123, B1124, B1125, B1126, B1127 DIAGNOSIS SENSOR UNIT

DTC Logic

INFOID:000000009649937

DTC DETECTION LOGIC

DTC	Display contents of CONSULT	DTC detecting condition	Possible cause
B1122 B1123 B1124 B1125 B1126 B1127	CONTROL UNIT	Air bag diagnosis sensor unit is malfunctioning	Malfunction in air bag diagnosis sensor unit

DTC CONFIRMATION PROCEDURE

1. CHECK SELF-DIAG RESULT

With CONSULT

1. Turn ignition switch ON.
2. Perform "Self Diagnostic Result" mode of "AIR BAG" using CONSULT.

Without CONSULT

1. Turn ignition switch ON.
2. Check the air bag warning lamp status. Refer to [SRC-15, "On Board Diagnosis Function"](#).

NOTE:

SRS does not enter the diagnosis mode if no malfunction is detected in the user mode.

Is malfunctioning part detected?

- YES >> Refer to [SRC-113, "Diagnosis Procedure"](#).
NO >> INSPECTION END

Diagnosis Procedure

INFOID:000000009649938

WARNING:

- Before servicing, turn ignition switch OFF, disconnect battery negative terminal, and wait at least 3 minutes or more. (To discharge backup capacitor.)
- Never use unspecified tester or other measuring device.

1. CHECK HARNESS CONNECTOR

Check the harness connector.

Is the inspection result normal?

- YES >> GO TO 2.
NO >> Replace harness connectors.

2. CHECK WIRING HARNESS

Check the wiring harness externals.

Is the inspection result normal?

- YES >> GO TO 3.
NO >> Replace wiring harness.

3. REPLACE AIR BAG DIAGNOSIS SENSOR UNIT

1. Replace air bag diagnosis sensor unit. Refer to [SR-29, "Removal and Installation"](#).
2. Perform DTC confirmation procedure. Refer to [SRC-113, "DTC Logic"](#).

Is DTC detected?

- YES >> GO TO 1.
NO >> INSPECTION END

B1129 SIDE AIR BAG MODULE RH

< DTC/CIRCUIT DIAGNOSIS >

B1129 SIDE AIR BAG MODULE RH

DTC Logic

INFOID:000000009649939

DTC DETECTION LOGIC

DTC	Display contents of CONSULT	DTC detecting condition	Possible cause
B1129	SIDE MODULE RH [OPEN]	Side air bag module RH circuit is open	<ul style="list-style-type: none">• Disconnection of wiring harness and open• Malfunction in side air bag module RH• Malfunction in air bag diagnosis sensor unit

DTC CONFIRMATION PROCEDURE

1.CHECK SELF-DIAG RESULT

Ⓟ With CONSULT

1. Turn ignition switch ON.
2. Perform "Self Diagnostic Result" mode of "AIR BAG" using CONSULT.

ⓧ Without CONSULT

1. Turn ignition switch ON.
2. Check the air bag warning lamp status. [SRC-15, "On Board Diagnosis Function"](#)

NOTE:

SRS does not enter the diagnosis mode if no malfunction is detected in the user mode.

Is malfunctioning part detected?

- YES >> Refer to [SRC-114, "Diagnosis Procedure"](#).
NO >> INSPECTION END

Diagnosis Procedure

INFOID:000000009649940

WARNING:

- Before servicing, turn ignition switch OFF, disconnect battery negative terminal, and wait at least 3 minutes or more. (To discharge backup capacitor.)
- Never use unspecified tester or other measuring device.

1.CHECK HARNESS CONNECTOR

Check the harness connector.

Is the inspection result normal?

- YES >> GO TO 2.
NO >> Replace harness connector.

2.CHECK WIRING HARNESS

Check the wiring harness externals.

Is the inspection result normal?

- YES >> GO TO 3.
NO >> Replace wiring harness.

3.REPLACE AIR BAG DIAGNOSIS SENSOR UNIT

1. Replace air bag diagnosis sensor unit. Refer to [SR-29, "Removal and Installation"](#).
2. Perform DTC confirmation procedure. Refer to [SRC-114, "DTC Logic"](#).

Is DTC detected?

- YES >> GO TO 4.
NO >> INSPECTION END

4.REPLACE SIDE AIR BAG MODULE

1. Replace side air bag module RH. Refer to [SE-90, "SEATBACK : Disassembly and Assembly"](#) (Manual seat), [SE-104, "SEATBACK : Disassembly and Assembly"](#) (Power seat).
2. Perform DTC confirmation procedure. Refer to [SRC-114, "DTC Logic"](#).

Is DTC detected?

B1129 SIDE AIR BAG MODULE RH

< DTC/CIRCUIT DIAGNOSIS >

YES >> GO TO 1.

NO >> INSPECTION END

A

B

C

D

E

F

G

SRC

I

J

K

L

M

N

O

P

B1130 SIDE AIR BAG MODULE RH

< DTC/CIRCUIT DIAGNOSIS >

B1130 SIDE AIR BAG MODULE RH

DTC Logic

INFOID:000000009649941

DTC DETECTION LOGIC

DTC	Display contents of CONSULT	DTC detecting condition	Possible cause
B1130	SIDE MODULE RH [VB-SHORT]	Side air bag module RH circuit is shorted to power supply circuit	<ul style="list-style-type: none">• Disconnection of wiring harness and short• Malfunction in side air bag module RH• Malfunction in air bag diagnosis sensor unit

DTC CONFIRMATION PROCEDURE

1. CHECK SELF-DIAG RESULT

With CONSULT

1. Turn ignition switch ON.
2. Perform "Self Diagnostic Result" mode of "AIR BAG" using CONSULT.

Without CONSULT

1. Turn ignition switch ON.
2. Check the air bag warning lamp status. Refer to [SRC-15, "On Board Diagnosis Function"](#).

NOTE:

SRS does not enter the diagnosis mode if no malfunction is detected in the user mode.

Is malfunctioning part detected?

- YES >> Refer to [SRC-116, "Diagnosis Procedure"](#).
NO >> INSPECTION END

Diagnosis Procedure

INFOID:000000009649942

WARNING:

- Before servicing, turn ignition switch OFF, disconnect battery negative terminal, and wait at least 3 minutes or more. (To discharge backup capacitor.)
- Never use unspecified tester or other measuring device.

1. CHECK HARNESS CONNECTOR

Check the harness connector.

Is the inspection result normal?

- YES >> GO TO 2.
NO >> Replace harness connector.

2. CHECK WIRING HARNESS

Check the wiring harness externals.

Is the inspection result normal?

- YES >> GO TO 3.
NO >> Replace wiring harness.

3. REPLACE AIR BAG DIAGNOSIS SENSOR UNIT

1. Replace air bag diagnosis sensor unit. Refer to [SR-29, "Removal and Installation"](#).
2. Perform DTC confirmation procedure. Refer to [SRC-116, "DTC Logic"](#).

Is DTC detected?

- YES >> GO TO 4.
NO >> INSPECTION END

4. REPLACE SIDE AIR BAG MODULE

1. Replace side air bag module RH. Refer to [SE-90, "SEATBACK : Disassembly and Assembly"](#) (Manual seat), [SE-104, "SEATBACK : Disassembly and Assembly"](#) (Power seat).
2. Perform DTC confirmation procedure. Refer to [SRC-116, "DTC Logic"](#).

Is DTC detected?

B1130 SIDE AIR BAG MODULE RH

< DTC/CIRCUIT DIAGNOSIS >

YES >> GO TO 1.

NO >> INSPECTION END

A

B

C

D

E

F

G

SRC

I

J

K

L

M

N

O

P

B1131 SIDE AIR BAG MODULE RH

< DTC/CIRCUIT DIAGNOSIS >

B1131 SIDE AIR BAG MODULE RH

DTC Logic

INFOID:000000009649943

DTC DETECTION LOGIC

DTC	Display contents of CONSULT	DTC detecting condition	Possible cause
B1131	SIDE MODULE RH [GND-SHORT]	Side air bag module RH circuit is shorted to ground	<ul style="list-style-type: none">• Disconnection of wiring harness and short• Malfunction in side air bag module RH• Malfunction in air bag diagnosis sensor unit

DTC CONFIRMATION PROCEDURE

1. CHECK SELF-DIAG RESULT

With CONSULT

1. Turn ignition switch ON.
2. Perform "Self Diagnostic Result" mode of "AIR BAG" using CONSULT.

Without CONSULT

1. Turn ignition switch ON.
2. Check the air bag warning lamp status. Refer to [SRC-15, "On Board Diagnosis Function"](#).

NOTE:

SRS does not enter the diagnosis mode if no malfunction is detected in the user mode.

Is malfunctioning part detected?

- YES >> Refer to [SRC-118, "Diagnosis Procedure"](#).
NO >> INSPECTION END

Diagnosis Procedure

INFOID:000000009649944

WARNING:

- Before servicing, turn ignition switch OFF, disconnect battery negative terminal, and wait at least 3 minutes or more. (To discharge backup capacitor.)
- Never use unspecified tester or other measuring device.

1. CHECK HARNESS CONNECTOR

Check the harness connector.

Is the inspection result normal?

- YES >> GO TO 2.
NO >> Replace harness connector.

2. CHECK WIRING HARNESS

Check the wiring harness externals.

Is the inspection result normal?

- YES >> GO TO 3.
NO >> Replace wiring harness.

3. REPLACE AIR BAG DIAGNOSIS SENSOR UNIT

1. Replace air bag diagnosis sensor unit. Refer to [SR-29, "Removal and Installation"](#).
2. Perform DTC confirmation procedure. Refer to [SRC-118, "DTC Logic"](#).

Is DTC detected?

- YES >> GO TO 4.
NO >> INSPECTION END

4. REPLACE SIDE AIR BAG MODULE

1. Replace side air bag module RH. Refer to [SE-90, "SEATBACK : Disassembly and Assembly"](#) (Manual seat), [SE-104, "SEATBACK : Disassembly and Assembly"](#) (Power seat).
2. Perform DTC confirmation procedure. Refer to [SRC-118, "DTC Logic"](#).

Is DTC detected?

B1131 SIDE AIR BAG MODULE RH

< DTC/CIRCUIT DIAGNOSIS >

YES >> GO TO 1.

NO >> INSPECTION END

A

B

C

D

E

F

G

SRC

I

J

K

L

M

N

O

P

B1132 SIDE AIR BAG MODULE RH

< DTC/CIRCUIT DIAGNOSIS >

B1132 SIDE AIR BAG MODULE RH

DTC Logic

INFOID:000000009649945

DTC DETECTION LOGIC

DTC	Display contents of CONSULT	DTC detecting condition	Possible cause
B1132	SIDE MODULE RH [SHORT]	Side air bag module RH circuits are shorted to each other	<ul style="list-style-type: none">• Disconnection of wiring harness and short• Malfunction in side air bag module RH• Malfunction in air bag diagnosis sensor unit

DTC CONFIRMATION PROCEDURE

1.CHECK SELF-DIAG RESULT

Ⓟ With CONSULT

1. Turn ignition switch ON.
2. Perform "Self Diagnostic Result" mode of "AIR BAG" using CONSULT.

ⓧ Without CONSULT

1. Turn ignition switch ON.
2. Check the air bag warning lamp status. Refer to [SRC-15, "On Board Diagnosis Function"](#).

NOTE:

SRS does not enter the diagnosis mode if no malfunction is detected in the user mode.

Is malfunctioning part detected?

- YES >> Refer to [SRC-120, "Diagnosis Procedure"](#).
NO >> INSPECTION END

Diagnosis Procedure

INFOID:000000009649946

WARNING:

- Before servicing, turn ignition switch OFF, disconnect battery negative terminal, and wait at least 3 minutes or more. (To discharge backup capacitor.)
- Never use unspecified tester or other measuring device.

1.CHECK HARNESS CONNECTOR

Check the harness connector.

Is the inspection result normal?

- YES >> GO TO 2.
NO >> Replace harness connector.

2.CHECK WIRING HARNESS

Check the wiring harness externals.

Is the inspection result normal?

- YES >> GO TO 3.
NO >> Replace wiring harness.

3.REPLACE AIR BAG DIAGNOSIS SENSOR UNIT

1. Replace air bag diagnosis sensor unit. Refer to [SR-29, "Removal and Installation"](#).
2. Perform DTC confirmation procedure. Refer to [SRC-120, "DTC Logic"](#).

Is DTC detected?

- YES >> GO TO 4.
NO >> INSPECTION END

4.REPLACE SIDE AIR BAG MODULE

1. Replace side air bag module RH. Refer to [SE-90, "SEATBACK : Disassembly and Assembly"](#) (Manual seat), [SE-104, "SEATBACK : Disassembly and Assembly"](#) (Power seat).
2. Perform DTC confirmation procedure. Refer to [SRC-120, "DTC Logic"](#).

Is DTC detected?

B1132 SIDE AIR BAG MODULE RH

< DTC/CIRCUIT DIAGNOSIS >

YES >> GO TO 1.

NO >> INSPECTION END

A

B

C

D

E

F

G

SRC

I

J

K

L

M

N

O

P

B1134 SIDE AIR BAG MODULE LH

< DTC/CIRCUIT DIAGNOSIS >

B1134 SIDE AIR BAG MODULE LH

DTC Logic

INFOID:000000009649947

DTC DETECTION LOGIC

DTC	Display contents of CONSULT	DTC detecting condition	Possible cause
B1134	SIDE MODULE LH [OPEN]	Side air bag module LH circuit is open	<ul style="list-style-type: none">• Disconnection of wiring harness and open• Malfunction in side air bag module LH• Malfunction in air bag diagnosis sensor unit

DTC CONFIRMATION PROCEDURE

1. CHECK SELF-DIAG RESULT

With CONSULT

1. Turn ignition switch ON.
2. Perform "Self Diagnostic Result" mode of "AIR BAG" using CONSULT.

Without CONSULT

1. Turn ignition switch ON.
2. Check the air bag warning lamp status. Refer to [SRC-15, "On Board Diagnosis Function"](#).

NOTE:

SRS does not enter the diagnosis mode if no malfunction is detected in the user mode.

Is malfunctioning part detected?

- YES >> Refer to [SRC-122, "Diagnosis Procedure"](#).
NO >> INSPECTION END

Diagnosis Procedure

INFOID:000000009649948

WARNING:

- Before servicing, turn ignition switch OFF, disconnect battery negative terminal, and wait at least 3 minutes or more. (To discharge backup capacitor.)
- Never use unspecified tester or other measuring device.

1. CHECK HARNESS CONNECTOR

Check the harness connector.

Is the inspection result normal?

- YES >> GO TO 2.
NO >> Replace harness connector.

2. CHECK WIRING HARNESS

Check the wiring harness externals.

Is the inspection result normal?

- YES >> GO TO 3.
NO >> Replace wiring harness.

3. REPLACE AIR BAG DIAGNOSIS SENSOR UNIT

1. Replace air bag diagnosis sensor unit. Refer to [SR-29, "Removal and Installation"](#).
2. Perform DTC confirmation procedure. Refer to [SRC-122, "DTC Logic"](#).

Is DTC detected?

- YES >> GO TO 4.
NO >> INSPECTION END

4. REPLACE SIDE AIR BAG MODULE

1. Replace side air bag module LH. Refer to [SE-90, "SEATBACK : Disassembly and Assembly"](#) (Manual seat), [SE-104, "SEATBACK : Disassembly and Assembly"](#) (Power seat).
2. Perform DTC confirmation procedure. Refer to [SRC-122, "DTC Logic"](#).

Is DTC detected?

B1134 SIDE AIR BAG MODULE LH

< DTC/CIRCUIT DIAGNOSIS >

YES >> GO TO 1.

NO >> INSPECTION END

A

B

C

D

E

F

G

SRC

I

J

K

L

M

N

O

P

B1135 SIDE AIR BAG MODULE LH

< DTC/CIRCUIT DIAGNOSIS >

B1135 SIDE AIR BAG MODULE LH

DTC Logic

INFOID:000000009649949

DTC DETECTION LOGIC

DTC	Display contents of CONSULT	DTC detecting condition	Possible cause
B1135	SIDE MODULE LH [VB-SHORT]	Side air bag module LH circuit is shorted to power supply circuit	<ul style="list-style-type: none">• Disconnection of wiring harness and short• Malfunction in side air bag module LH• Malfunction in air bag diagnosis sensor unit

DTC CONFIRMATION PROCEDURE

1. CHECK SELF-DIAG RESULT

With CONSULT

1. Turn ignition switch ON.
2. Perform "Self Diagnostic Result" mode of "AIR BAG" using CONSULT.

Without CONSULT

1. Turn ignition switch ON.
2. Check the air bag warning lamp status. Refer to [SRC-15, "On Board Diagnosis Function"](#).

NOTE:

SRS does not enter the diagnosis mode if no malfunction is detected in the user mode.

Is malfunctioning part detected?

- YES >> Refer to [SRC-124, "Diagnosis Procedure"](#).
NO >> INSPECTION END

Diagnosis Procedure

INFOID:000000009649950

WARNING:

- Before servicing, turn ignition switch OFF, disconnect battery negative terminal, and wait at least 3 minutes or more. (To discharge backup capacitor.)
- Never use unspecified tester or other measuring device.

1. CHECK HARNESS CONNECTOR

Check the harness connector.

Is the inspection result normal?

- YES >> GO TO 2.
NO >> Replace harness connector.

2. CHECK WIRING HARNESS

Check the wiring harness externals.

Is the inspection result normal?

- YES >> GO TO 3.
NO >> Replace wiring harness.

3. REPLACE AIR BAG DIAGNOSIS SENSOR UNIT

1. Replace air bag diagnosis sensor unit. Refer to [SR-29, "Removal and Installation"](#).
2. Perform DTC confirmation procedure. Refer to [SRC-124, "DTC Logic"](#).

Is DTC detected?

- YES >> GO TO 4.
NO >> INSPECTION END

4. REPLACE SIDE AIR BAG MODULE

1. Replace side air bag module LH. Refer to [SE-90, "SEATBACK : Disassembly and Assembly"](#) (Manual seat), [SE-104, "SEATBACK : Disassembly and Assembly"](#) (Power seat).
2. Perform DTC confirmation procedure. Refer to [SRC-124, "DTC Logic"](#).

Is DTC detected?

B1135 SIDE AIR BAG MODULE LH

< DTC/CIRCUIT DIAGNOSIS >

YES >> GO TO 1.

NO >> INSPECTION END

A

B

C

D

E

F

G

SRC

I

J

K

L

M

N

O

P

B1136 SIDE AIR BAG MODULE LH

< DTC/CIRCUIT DIAGNOSIS >

B1136 SIDE AIR BAG MODULE LH

DTC Logic

INFOID:000000009649951

DTC DETECTION LOGIC

DTC	Display contents of CONSULT	DTC detecting condition	Possible cause
B1136	SIDE MODULE LH [GND-SHORT]	Side air bag module LH circuit is shorted to ground	<ul style="list-style-type: none">• Disconnection of wiring harness and short• Malfunction in side air bag module LH• Malfunction in air bag diagnosis sensor unit

DTC CONFIRMATION PROCEDURE

1. CHECK SELF-DIAG RESULT

With CONSULT

1. Turn ignition switch ON.
2. Perform "Self Diagnostic Result" mode of "AIR BAG" using CONSULT.

Without CONSULT

1. Turn ignition switch ON.
2. Check the air bag warning lamp status. Refer to [SRC-15, "On Board Diagnosis Function"](#).

NOTE:

SRS does not enter the diagnosis mode if no malfunction is detected in the user mode.

Is malfunctioning part detected?

- YES >> Refer to [SRC-126, "Diagnosis Procedure"](#).
NO >> INSPECTION END

Diagnosis Procedure

INFOID:000000009649952

WARNING:

- Before servicing, turn ignition switch OFF, disconnect battery negative terminal, and wait at least 3 minutes or more. (To discharge backup capacitor.)
- Never use unspecified tester or other measuring device.

1. CHECK HARNESS CONNECTOR

Check the harness connector.

Is the inspection result normal?

- YES >> GO TO 2.
NO >> Replace harness connector.

2. CHECK WIRING HARNESS

Check the wiring harness externals.

Is the inspection result normal?

- YES >> GO TO 3.
NO >> Replace wiring harness.

3. REPLACE AIR BAG DIAGNOSIS SENSOR UNIT

1. Replace air bag diagnosis sensor unit. Refer to [SR-29, "Removal and Installation"](#).
2. Perform DTC confirmation procedure. Refer to [SRC-126, "DTC Logic"](#).

Is DTC detected?

- YES >> GO TO 4.
NO >> INSPECTION END

4. REPLACE SIDE AIR BAG MODULE

1. Replace side air bag module LH. Refer to [SE-90, "SEATBACK : Disassembly and Assembly"](#) (Manual seat), [SE-104, "SEATBACK : Disassembly and Assembly"](#) (Power seat).
2. Perform DTC confirmation procedure. Refer to [SRC-126, "DTC Logic"](#).

Is DTC detected?

B1136 SIDE AIR BAG MODULE LH

< DTC/CIRCUIT DIAGNOSIS >

YES >> GO TO 1.

NO >> INSPECTION END

A

B

C

D

E

F

G

SRC

I

J

K

L

M

N

O

P

B1137 SIDE AIR BAG MODULE LH

< DTC/CIRCUIT DIAGNOSIS >

B1137 SIDE AIR BAG MODULE LH

DTC Logic

INFOID:000000009649953

DTC DETECTION LOGIC

DTC	Display contents of CONSULT	DTC detecting condition	Possible cause
B1137	SIDE MODULE LH [SHORT]	Side air bag module LH circuits are shorted to each other	<ul style="list-style-type: none">• Disconnection of wiring harness and short• Malfunction in side air bag module LH• Malfunction in air bag diagnosis sensor unit

DTC CONFIRMATION PROCEDURE

1. CHECK SELF-DIAG RESULT

With CONSULT

1. Turn ignition switch ON.
2. Perform "Self Diagnostic Result" mode of "AIR BAG" using CONSULT.

Without CONSULT

1. Turn ignition switch ON.
2. Check the air bag warning lamp status. Refer to [SRC-15, "On Board Diagnosis Function"](#).

NOTE:

SRS does not enter the diagnosis mode if no malfunction is detected in the user mode.

Is malfunctioning part detected?

- YES >> Refer to [SRC-128, "Diagnosis Procedure"](#).
NO >> INSPECTION END

Diagnosis Procedure

INFOID:000000009649954

WARNING:

- Before servicing, turn ignition switch OFF, disconnect battery negative terminal, and wait at least 3 minutes or more. (To discharge backup capacitor.)
- Never use unspecified tester or other measuring device.

1. CHECK HARNESS CONNECTOR

Check the harness connector.

Is the inspection result normal?

- YES >> GO TO 2.
NO >> Replace harness connector.

2. CHECK WIRING HARNESS

Check the wiring harness externals.

Is the inspection result normal?

- YES >> GO TO 3.
NO >> Replace wiring harness.

3. REPLACE AIR BAG DIAGNOSIS SENSOR UNIT

1. Replace air bag diagnosis sensor unit. Refer to [SR-29, "Removal and Installation"](#).
2. Perform DTC confirmation procedure. Refer to [SRC-128, "DTC Logic"](#).

Is DTC detected?

- YES >> GO TO 4.
NO >> INSPECTION END

4. REPLACE SIDE AIR BAG MODULE

1. Replace side air bag module LH. Refer to [SE-90, "SEATBACK : Disassembly and Assembly"](#) (Manual seat), [SE-104, "SEATBACK : Disassembly and Assembly"](#) (Power seat).
2. Perform DTC confirmation procedure. Refer to [SRC-128, "DTC Logic"](#).

Is DTC detected?

B1137 SIDE AIR BAG MODULE LH

< DTC/CIRCUIT DIAGNOSIS >

YES >> GO TO 1.

NO >> INSPECTION END

A

B

C

D

E

F

G

SRC

I

J

K

L

M

N

O

P

B1138, B1139, B1140, B1141, B1142, B1143 DIAGNOSIS SENSOR UNIT

< DTC/CIRCUIT DIAGNOSIS >

B1138, B1139, B1140, B1141, B1142, B1143 DIAGNOSIS SENSOR UNIT

DTC Logic

INFOID:000000009649955

DTC DETECTION LOGIC

DTC	Display contents of CONSULT	DTC detecting condition	Possible cause
B1138 B1139 B1140 B1141 B1142 B1143	CONTROL UNIT	Air bag diagnosis sensor unit is malfunctioning	Malfunction in air bag diagnosis sensor unit

DTC CONFIRMATION PROCEDURE

1. CHECK SELF-DIAG RESULT

With CONSULT

1. Turn ignition switch ON.
2. Perform "Self Diagnostic Result" mode of "AIR BAG" using CONSULT.

Without CONSULT

1. Turn ignition switch ON.
2. Check the air bag warning lamp status. Refer to [SRC-15, "On Board Diagnosis Function"](#).

NOTE:

SRS does not enter the diagnosis mode if no malfunction is detected in the user mode.

Is malfunctioning part detected?

- YES >> Refer to [SRC-130, "Diagnosis Procedure"](#).
NO >> INSPECTION END

Diagnosis Procedure

INFOID:000000009649956

WARNING:

- Before servicing, turn ignition switch OFF, disconnect battery negative terminal, and wait at least 3 minutes or more. (To discharge backup capacitor.)
- Never use unspecified tester or other measuring device.

1. CHECK HARNESS CONNECTOR

Check the harness connector.

Is the inspection result normal?

- YES >> GO TO 2.
NO >> Replace harness connectors.

2. CHECK WIRING HARNESS

Check the wiring harness externals.

Is the inspection result normal?

- YES >> GO TO 3.
NO >> Replace wiring harness.

3. REPLACE AIR BAG DIAGNOSIS SENSOR UNIT

1. Replace air bag diagnosis sensor unit. Refer to [SR-29, "Removal and Installation"](#).
2. Perform DTC confirmation procedure. Refer to [SRC-130, "DTC Logic"](#).

Is DTC detected?

- YES >> GO TO 1.
NO >> INSPECTION END

B1144 DIAGNOSIS SENSOR UNIT

< DTC/CIRCUIT DIAGNOSIS >

B1144 DIAGNOSIS SENSOR UNIT

DTC Logic

INFOID:000000009649957

DTC DETECTION LOGIC

DTC	Display contents of CONSULT	DTC detecting condition	Possible cause
B1144	CONTROL UNIT [MISS INSTALLATION]	Air bag diagnosis sensor unit is malfunctioning or out of the specification	<ul style="list-style-type: none">Malfunction in air bag diagnosis sensor unitConfiguration in air bag diagnosis sensor unit does not match the vehicles specification

DTC CONFIRMATION PROCEDURE

1. CHECK SELF-DIAG RESULT

With CONSULT

- Turn ignition switch ON.
- Perform "Self Diagnostic Result" mode of "AIR BAG" using CONSULT.

Without CONSULT

- Turn ignition switch ON.
- Check the air bag warning lamp status. Refer to [SRC-15, "On Board Diagnosis Function"](#).

NOTE:

SRS does not enter the diagnosis mode if no malfunction is detected in the user mode.

Is malfunctioning part detected?

- YES >> Refer to [SRC-131, "Diagnosis Procedure"](#).
NO >> INSPECTION END

Diagnosis Procedure

INFOID:000000009649958

WARNING:

- Before servicing, turn ignition switch OFF, disconnect battery negative terminal, and wait at least 3 minutes or more. (To discharge backup capacitor.)
- Never use unspecified tester or other measuring device.

1. CHECK HARNESS CONNECTOR

Check the harness connector.

Is the inspection result normal?

- YES >> GO TO 2.
NO >> Replace harness connectors.

2. CHECK WIRING HARNESS

Check the wiring harness externals.

Is the inspection result normal?

- YES >> GO TO 3.
NO >> Replace wiring harness.

3. REPLACE AIR BAG DIAGNOSIS SENSOR UNIT

- Replace air bag diagnosis sensor unit. Refer to [SR-29, "Removal and Installation"](#).
- Perform DTC confirmation procedure. Refer to [SRC-131, "DTC Logic"](#).

Is DTC detected?

- YES >> GO TO 1.
NO >> INSPECTION END

B1145 CURTAIN AIR BAG MODULE RH

< DTC/CIRCUIT DIAGNOSIS >

B1145 CURTAIN AIR BAG MODULE RH

DTC Logic

INFOID:000000009649959

DTC DETECTION LOGIC

DTC	Display contents of CONSULT	DTC detecting condition	Possible cause
B1145	CURTAIN MODULE RH [OPEN]	Rear curtain air bag module RH circuit is open	<ul style="list-style-type: none">• Disconnection of wiring harness and open• Malfunction in rear curtain air bag module RH• Malfunction in air bag diagnosis sensor unit

DTC CONFIRMATION PROCEDURE

1. CHECK SELF-DIAG RESULT

With CONSULT

1. Turn ignition switch ON.
2. Perform "Self Diagnostic Result" mode of "AIR BAG" using CONSULT.

Without CONSULT

1. Turn ignition switch ON.
2. Check the air bag warning lamp status. Refer to [SRC-15, "On Board Diagnosis Function"](#).

NOTE:

SRS does not enter the diagnosis mode if no malfunction is detected in the user mode.

Is malfunctioning part detected?

- YES >> Refer to [SRC-132, "Diagnosis Procedure"](#).
NO >> INSPECTION END

Diagnosis Procedure

INFOID:000000009649960

WARNING:

- Before servicing, turn ignition switch OFF, disconnect battery negative terminal, and wait at least 3 minutes or more. (To discharge backup capacitor.)
- Never use unspecified tester or other measuring device.

1. CHECK HARNESS CONNECTOR

Check the harness connector.

Is the inspection result normal?

- YES >> GO TO 2.
NO >> Replace harness connector.

2. CHECK WIRING HARNESS

Check the wiring harness externals.

Is the inspection result normal?

- YES >> GO TO 3.
NO >> Replace wiring harness.

3. REPLACE AIR BAG DIAGNOSIS SENSOR UNIT

1. Replace air bag diagnosis sensor unit. Refer to [SR-29, "Removal and Installation"](#).
2. Perform DTC confirmation procedure. Refer to [SRC-132, "DTC Logic"](#).

Is DTC detected?

- YES >> GO TO 4.
NO >> INSPECTION END

4. REPLACE REAR CURTAIN AIR BAG MODULE

1. Replace rear curtain air bag module RH. Refer to [SR-21, "Removal and Installation"](#).
2. Perform DTC confirmation procedure. Refer to [SRC-132, "DTC Logic"](#).

Is DTC detected?

- YES >> GO TO 1.

B1145 CURTAIN AIR BAG MODULE RH

< DTC/CIRCUIT DIAGNOSIS >

NO >> INSPECTION END

A

B

C

D

E

F

G

SRC

I

J

K

L

M

N

O

P

B1146 CURTAIN AIR BAG MODULE RH

< DTC/CIRCUIT DIAGNOSIS >

B1146 CURTAIN AIR BAG MODULE RH

DTC Logic

INFOID:000000009649961

DTC DETECTION LOGIC

DTC	Display contents of CONSULT	DTC detecting condition	Possible cause
B1146	CURTAIN MODULE RH [VB-SHORT]	Rear curtain air bag module RH circuit is shorted to power supply circuit	<ul style="list-style-type: none">• Disconnection of wiring harness and short• Malfunction in rear curtain air bag module RH• Malfunction in air bag diagnosis sensor unit

DTC CONFIRMATION PROCEDURE

1. CHECK SELF-DIAG RESULT

With CONSULT

1. Turn ignition switch ON.
2. Perform "Self Diagnostic Result" mode of "AIR BAG" using CONSULT.

Without CONSULT

1. Turn ignition switch ON.
2. Check the air bag warning lamp status. Refer to [SRC-15, "On Board Diagnosis Function"](#).

NOTE:

SRS does not enter the diagnosis mode if no malfunction is detected in the user mode.

Is malfunctioning part detected?

- YES >> Refer to [SRC-134, "Diagnosis Procedure"](#).
NO >> INSPECTION END

Diagnosis Procedure

INFOID:000000009649962

WARNING:

- Before servicing, turn ignition switch OFF, disconnect battery negative terminal, and wait at least 3 minutes or more. (To discharge backup capacitor.)
- Never use unspecified tester or other measuring device.

1. CHECK HARNESS CONNECTOR

Check the harness connector.

Is the inspection result normal?

- YES >> GO TO 2.
NO >> Replace harness connector.

2. CHECK WIRING HARNESS

Check the wiring harness externals.

Is the inspection result normal?

- YES >> GO TO 3.
NO >> Replace wiring harness.

3. REPLACE AIR BAG DIAGNOSIS SENSOR UNIT

1. Replace air bag diagnosis sensor unit. Refer to [SR-29, "Removal and Installation"](#).
2. Perform DTC confirmation procedure. Refer to [SRC-134, "DTC Logic"](#).

Is DTC detected?

- YES >> GO TO 4.
NO >> INSPECTION END

4. REPLACE REAR CURTAIN AIR BAG MODULE

1. Replace rear curtain air bag module RH. Refer to [SR-21, "Removal and Installation"](#).
2. Perform DTC confirmation procedure. Refer to [SRC-134, "DTC Logic"](#).

Is DTC detected?

- YES >> GO TO 1.

B1146 CURTAIN AIR BAG MODULE RH

< DTC/CIRCUIT DIAGNOSIS >

NO >> INSPECTION END

A

B

C

D

E

F

G

SRC

I

J

K

L

M

N

O

P

B1147 CURTAIN AIR BAG MODULE RH

< DTC/CIRCUIT DIAGNOSIS >

B1147 CURTAIN AIR BAG MODULE RH

DTC Logic

INFOID:000000009649963

DTC DETECTION LOGIC

DTC	Display contents of CONSULT	DTC detecting condition	Possible cause
B1147	CURTAIN MODULE RH [GND-SHORT]	Rear curtain air bag module RH circuit is shorted to ground	<ul style="list-style-type: none">• Disconnection of wiring harness and short• Malfunction in rear curtain air bag module RH• Malfunction in air bag diagnosis sensor unit

DTC CONFIRMATION PROCEDURE

1.CHECK SELF-DIAG RESULT

With CONSULT

1. Turn ignition switch ON.
2. Perform "Self Diagnostic Result" mode of "AIR BAG" using CONSULT.

Without CONSULT

1. Turn ignition switch ON.
2. Check the air bag warning lamp status. Refer to [SRC-15, "On Board Diagnosis Function"](#).

NOTE:

SRS does not enter the diagnosis mode if no malfunction is detected in the user mode.

Is malfunctioning part detected?

- YES >> Refer to [SRC-136, "Diagnosis Procedure"](#).
NO >> INSPECTION END

Diagnosis Procedure

INFOID:000000009649964

WARNING:

- Before servicing, turn ignition switch OFF, disconnect battery negative terminal, and wait at least 3 minutes or more. (To discharge backup capacitor.)
- Never use unspecified tester or other measuring device.

1.CHECK HARNESS CONNECTOR

Check the harness connector.

Is the inspection result normal?

- YES >> GO TO 2.
NO >> Replace harness connector.

2.CHECK WIRING HARNESS

Check the wiring harness externals.

Is the inspection result normal?

- YES >> GO TO 3.
NO >> Replace wiring harness.

3.REPLACE AIR BAG DIAGNOSIS SENSOR UNIT

1. Replace air bag diagnosis sensor unit. Refer to [SR-29, "Removal and Installation"](#).
2. Perform DTC confirmation procedure. Refer to [SRC-136, "DTC Logic"](#).

Is DTC detected?

- YES >> GO TO 4.
NO >> INSPECTION END

4.REPLACE REAR CURTAIN AIR BAG MODULE

1. Replace rear curtain air bag module RH. Refer to [SR-21, "Removal and Installation"](#).
2. Perform DTC confirmation procedure. Refer to [SRC-136, "DTC Logic"](#).

Is DTC detected?

- YES >> GO TO 1.

B1147 CURTAIN AIR BAG MODULE RH

< DTC/CIRCUIT DIAGNOSIS >

NO >> INSPECTION END

A

B

C

D

E

F

G

SRC

I

J

K

L

M

N

O

P

B1148 CURTAIN AIR BAG MODULE RH

< DTC/CIRCUIT DIAGNOSIS >

B1148 CURTAIN AIR BAG MODULE RH

DTC Logic

INFOID:000000009649965

DTC DETECTION LOGIC

DTC	Display contents of CONSULT	DTC detecting condition	Possible cause
B1148	CURTAIN MODULE RH [SHORT]	Rear curtain air bag module RH circuits are shorted to each other	<ul style="list-style-type: none">• Disconnection of wiring harness and short• Malfunction in rear curtain air bag module RH• Malfunction in air bag diagnosis sensor unit

DTC CONFIRMATION PROCEDURE

1.CHECK SELF-DIAG RESULT

Ⓟ With CONSULT

1. Turn ignition switch ON.
2. Perform "Self Diagnostic Result" mode of "AIR BAG" using CONSULT.

ⓧ Without CONSULT

1. Turn ignition switch ON.
2. Check the air bag warning lamp status. Refer to [SRC-15, "On Board Diagnosis Function"](#).

NOTE:

SRS does not enter the diagnosis mode if no malfunction is detected in the user mode.

Is malfunctioning part detected?

- YES >> Refer to [SRC-138, "Diagnosis Procedure"](#).
NO >> INSPECTION END

Diagnosis Procedure

INFOID:000000009649966

WARNING:

- Before servicing, turn ignition switch OFF, disconnect battery negative terminal, and wait at least 3 minutes or more. (To discharge backup capacitor.)
- Never use unspecified tester or other measuring device.

1.CHECK HARNESS CONNECTOR

Check the harness connector.

Is the inspection result normal?

- YES >> GO TO 2.
NO >> Replace harness connector.

2.CHECK WIRING HARNESS

Check the wiring harness externals.

Is the inspection result normal?

- YES >> GO TO 3.
NO >> Replace wiring harness.

3.REPLACE AIR BAG DIAGNOSIS SENSOR UNIT

1. Replace air bag diagnosis sensor unit. Refer to [SR-29, "Removal and Installation"](#).
2. Perform DTC confirmation procedure. Refer to [SRC-138, "DTC Logic"](#).

Is DTC detected?

- YES >> GO TO 4.
NO >> INSPECTION END

4.REPLACE REAR CURTAIN AIR BAG MODULE

1. Replace rear curtain air bag module RH. Refer to [SR-21, "Removal and Installation"](#).
2. Perform DTC confirmation procedure. Refer to [SRC-138, "DTC Logic"](#).

Is DTC detected?

- YES >> GO TO 1.

B1148 CURTAIN AIR BAG MODULE RH

< DTC/CIRCUIT DIAGNOSIS >

NO >> INSPECTION END

A

B

C

D

E

F

G

SRC

I

J

K

L

M

N

O

P

B1150 CURTAIN AIR BAG MODULE LH

< DTC/CIRCUIT DIAGNOSIS >

B1150 CURTAIN AIR BAG MODULE LH

DTC Logic

INFOID:000000009649967

DTC DETECTION LOGIC

DTC	Display contents of CONSULT	DTC detecting condition	Possible cause
B1150	CURTAIN MODULE LH [OPEN]	Rear curtain air bag module LH circuit is open	<ul style="list-style-type: none">• Disconnection of wiring harness and open• Malfunction in rear curtain air bag module LH• Malfunction in air bag diagnosis sensor unit

DTC CONFIRMATION PROCEDURE

1. CHECK SELF-DIAG RESULT

With CONSULT

1. Turn ignition switch ON.
2. Perform "Self Diagnostic Result" mode of "AIR BAG" using CONSULT.

Without CONSULT

1. Turn ignition switch ON.
2. Check the air bag warning lamp status. Refer to [SRC-15, "On Board Diagnosis Function"](#).

NOTE:

SRS does not enter the diagnosis mode if no malfunction is detected in the user mode.

Is malfunctioning part detected?

- YES >> Refer to [SRC-140, "Diagnosis Procedure"](#).
NO >> INSPECTION END

Diagnosis Procedure

INFOID:000000009649968

WARNING:

- Before servicing, turn ignition switch OFF, disconnect battery negative terminal, and wait at least 3 minutes or more. (To discharge backup capacitor.)
- Never use unspecified tester or other measuring device.

1. CHECK HARNESS CONNECTOR

Check the harness connector.

Is the inspection result normal?

- YES >> GO TO 2.
NO >> Replace harness connector.

2. CHECK WIRING HARNESS

Check the wiring harness externals.

Is the inspection result normal?

- YES >> GO TO 3.
NO >> Replace wiring harness.

3. REPLACE AIR BAG DIAGNOSIS SENSOR UNIT

1. Replace air bag diagnosis sensor unit. Refer to [SR-29, "Removal and Installation"](#).
2. Perform DTC confirmation procedure. Refer to [SRC-140, "DTC Logic"](#).

Is DTC detected?

- YES >> GO TO 4.
NO >> INSPECTION END

4. REPLACE REAR CURTAIN AIR BAG MODULE

1. Replace rear curtain air bag module LH. Refer to [SR-21, "Removal and Installation"](#).
2. Perform DTC confirmation procedure. Refer to [SRC-140, "DTC Logic"](#).

Is DTC detected?

- YES >> GO TO 1.

B1150 CURTAIN AIR BAG MODULE LH

< DTC/CIRCUIT DIAGNOSIS >

NO >> INSPECTION END

A

B

C

D

E

F

G

SRC

I

J

K

L

M

N

O

P

B1151 CURTAIN AIR BAG MODULE LH

< DTC/CIRCUIT DIAGNOSIS >

B1151 CURTAIN AIR BAG MODULE LH

DTC Logic

INFOID:000000009649969

DTC DETECTION LOGIC

DTC	Display contents of CONSULT	DTC detecting condition	Possible cause
B1151	CURTAIN MODULE LH [VB-SHORT]	Rear curtain air bag module LH circuit is shorted to power supply circuit	<ul style="list-style-type: none">• Disconnection of wiring harness and short• Malfunction in rear curtain air bag module LH• Malfunction in air bag diagnosis sensor unit

DTC CONFIRMATION PROCEDURE

1.CHECK SELF-DIAG RESULT

Ⓟ With CONSULT

1. Turn ignition switch ON.
2. Perform "Self Diagnostic Result" mode of "AIR BAG" using CONSULT.

ⓧ Without CONSULT

1. Turn ignition switch ON.
2. Check the air bag warning lamp status. Refer to [SRC-15, "On Board Diagnosis Function"](#).

NOTE:

SRS does not enter the diagnosis mode if no malfunction is detected in the user mode.

Is malfunctioning part detected?

- YES >> Refer to [SRC-142, "Diagnosis Procedure"](#).
NO >> INSPECTION END

Diagnosis Procedure

INFOID:000000009649970

WARNING:

- Before servicing, turn ignition switch OFF, disconnect battery negative terminal, and wait at least 3 minutes or more. (To discharge backup capacitor.)
- Never use unspecified tester or other measuring device.

1.CHECK HARNESS CONNECTOR

Check the harness connector.

Is the inspection result normal?

- YES >> GO TO 2.
NO >> Replace harness connector.

2.CHECK WIRING HARNESS

Check the wiring harness externals.

Is the inspection result normal?

- YES >> GO TO 3.
NO >> Replace wiring harness.

3.REPLACE AIR BAG DIAGNOSIS SENSOR UNIT

1. Replace air bag diagnosis sensor unit. Refer to [SR-29, "Removal and Installation"](#).
2. Perform DTC confirmation procedure. Refer to [SRC-142, "DTC Logic"](#).

Is DTC detected?

- YES >> GO TO 4.
NO >> INSPECTION END

4.REPLACE REAR CURTAIN AIR BAG MODULE

1. Replace rear curtain air bag module LH. Refer to [SR-21, "Removal and Installation"](#).
2. Perform DTC confirmation procedure. Refer to [SRC-142, "DTC Logic"](#).

Is DTC detected?

- YES >> GO TO 1.

B1151 CURTAIN AIR BAG MODULE LH

< DTC/CIRCUIT DIAGNOSIS >

NO >> INSPECTION END

A

B

C

D

E

F

G

SRC

I

J

K

L

M

N

O

P

B1152 CURTAIN AIR BAG MODULE LH

< DTC/CIRCUIT DIAGNOSIS >

B1152 CURTAIN AIR BAG MODULE LH

DTC Logic

INFOID:000000009649971

DTC DETECTION LOGIC

DTC	Display contents of CONSULT	DTC detecting condition	Possible cause
B1152	CURTAIN MODULE LH [GND-SHORT]	Rear curtain air bag module LH circuit is shorted to ground	<ul style="list-style-type: none">• Disconnection of wiring harness and short• Malfunction in rear curtain air bag module LH• Malfunction in air bag diagnosis sensor unit

DTC CONFIRMATION PROCEDURE

1. CHECK SELF-DIAG RESULT

With CONSULT

1. Turn ignition switch ON.
2. Perform "Self Diagnostic Result" mode of "AIR BAG" using CONSULT.

Without CONSULT

1. Turn ignition switch ON.
2. Check the air bag warning lamp status. Refer to [SRC-15, "On Board Diagnosis Function"](#).

NOTE:

SRS does not enter the diagnosis mode if no malfunction is detected in the user mode.

Is malfunctioning part detected?

- YES >> Refer to [SRC-144, "Diagnosis Procedure"](#).
NO >> INSPECTION END

Diagnosis Procedure

INFOID:000000009649972

WARNING:

- Before servicing, turn ignition switch OFF, disconnect battery negative terminal, and wait at least 3 minutes or more. (To discharge backup capacitor.)
- Never use unspecified tester or other measuring device.

1. CHECK HARNESS CONNECTOR

Check the harness connector.

Is the inspection result normal?

- YES >> GO TO 2.
NO >> Replace harness connector.

2. CHECK WIRING HARNESS

Check the wiring harness externals.

Is the inspection result normal?

- YES >> GO TO 3.
NO >> Replace wiring harness.

3. REPLACE AIR BAG DIAGNOSIS SENSOR UNIT

1. Replace air bag diagnosis sensor unit. Refer to [SR-29, "Removal and Installation"](#).
2. Perform DTC confirmation procedure. Refer to [SRC-144, "DTC Logic"](#).

Is DTC detected?

- YES >> GO TO 4.
NO >> INSPECTION END

4. REPLACE REAR CURTAIN AIR BAG MODULE

1. Replace rear curtain air bag module LH. Refer to [SR-21, "Removal and Installation"](#).
2. Perform DTC confirmation procedure. Refer to [SRC-144, "DTC Logic"](#).

Is DTC detected?

- YES >> GO TO 1.

B1152 CURTAIN AIR BAG MODULE LH

< DTC/CIRCUIT DIAGNOSIS >

NO >> INSPECTION END

A

B

C

D

E

F

G

SRC

I

J

K

L

M

N

O

P

B1153 CURTAIN AIR BAG MODULE LH

< DTC/CIRCUIT DIAGNOSIS >

B1153 CURTAIN AIR BAG MODULE LH

DTC Logic

INFOID:000000009649973

DTC DETECTION LOGIC

DTC	Display contents of CONSULT	DTC detecting condition	Possible cause
B1153	CURTAIN MODULE LH [SHORT]	Rear curtain air bag module LH circuits are shorted to each other	<ul style="list-style-type: none">• Disconnection of wiring harness and short• Malfunction in rear curtain air bag module LH• Malfunction in air bag diagnosis sensor unit

DTC CONFIRMATION PROCEDURE

1. CHECK SELF-DIAG RESULT

With CONSULT

1. Turn ignition switch ON.
2. Perform "Self Diagnostic Result" mode of "AIR BAG" using CONSULT.

Without CONSULT

1. Turn ignition switch ON.
2. Check the air bag warning lamp status. Refer to [SRC-15, "On Board Diagnosis Function"](#).

NOTE:

SRS does not enter the diagnosis mode if no malfunction is detected in the user mode.

Is malfunctioning part detected?

- YES >> Refer to [SRC-146, "Diagnosis Procedure"](#).
NO >> INSPECTION END

Diagnosis Procedure

INFOID:000000009649974

WARNING:

- Before servicing, turn ignition switch OFF, disconnect battery negative terminal, and wait at least 3 minutes or more. (To discharge backup capacitor.)
- Never use unspecified tester or other measuring device.

1. CHECK HARNESS CONNECTOR

Check the harness connector.

Is the inspection result normal?

- YES >> GO TO 2.
NO >> Replace harness connector.

2. CHECK WIRING HARNESS

Check the wiring harness externals.

Is the inspection result normal?

- YES >> GO TO 3.
NO >> Replace wiring harness.

3. REPLACE AIR BAG DIAGNOSIS SENSOR UNIT

1. Replace air bag diagnosis sensor unit. Refer to [SR-29, "Removal and Installation"](#).
2. Perform DTC confirmation procedure. Refer to [SRC-146, "DTC Logic"](#).

Is DTC detected?

- YES >> GO TO 4.
NO >> INSPECTION END

4. REPLACE REAR CURTAIN AIR BAG MODULE

1. Replace rear curtain air bag module LH. Refer to [SR-21, "Removal and Installation"](#).
2. Perform DTC confirmation procedure. Refer to [SRC-146, "DTC Logic"](#).

Is DTC detected?

- YES >> GO TO 1.

B1153 CURTAIN AIR BAG MODULE LH

< DTC/CIRCUIT DIAGNOSIS >

NO >> INSPECTION END

A

B

C

D

E

F

G

SRC

I

J

K

L

M

N

O

P

B1154, B1155, B1156, B1157, B1158, B1159 DIAGNOSIS SENSOR UNIT

< DTC/CIRCUIT DIAGNOSIS >

B1154, B1155, B1156, B1157, B1158, B1159 DIAGNOSIS SENSOR UNIT

DTC Logic

INFOID:000000009649975

DTC DETECTION LOGIC

DTC	Display contents of CONSULT	DTC detecting condition	Possible cause
B1154 B1155 B1156 B1157 B1158 B1159	CONTROL UNIT	Air bag diagnosis sensor unit is malfunctioning	Malfunction in air bag diagnosis sensor unit

DTC CONFIRMATION PROCEDURE

1. CHECK SELF-DIAG RESULT

With CONSULT

1. Turn ignition switch ON.
2. Perform "Self Diagnostic Result" mode of "AIR BAG" using CONSULT.

Without CONSULT

1. Turn ignition switch ON.
2. Check the air bag warning lamp status. Refer to [SRC-15, "On Board Diagnosis Function"](#).

NOTE:

SRS does not enter the diagnosis mode if no malfunction is detected in the user mode.

Is malfunctioning part detected?

- YES >> Refer to [SRC-148, "Diagnosis Procedure"](#).
NO >> INSPECTION END

Diagnosis Procedure

INFOID:000000009649976

WARNING:

- Before servicing, turn ignition switch OFF, disconnect battery negative terminal, and wait at least 3 minutes or more. (To discharge backup capacitor.)
- Never use unspecified tester or other measuring device.

1. CHECK HARNESS CONNECTOR

Check the harness connector.

Is the inspection result normal?

- YES >> GO TO 2.
NO >> Replace harness connectors.

2. CHECK WIRING HARNESS

Check the wiring harness externals.

Is the inspection result normal?

- YES >> GO TO 3.
NO >> Replace wiring harness.

3. REPLACE AIR BAG DIAGNOSIS SENSOR UNIT

1. Replace air bag diagnosis sensor unit. Refer to [SR-29, "Removal and Installation"](#).
2. Perform DTC confirmation procedure. Refer to [SRC-148, "DTC Logic"](#).

Is DTC detected?

- YES >> GO TO 1.
NO >> INSPECTION END

B1170, B1171, B1172, B1173, B1174, B1175 DIAGNOSIS SENSOR UNIT

< DTC/CIRCUIT DIAGNOSIS >

B1170, B1171, B1172, B1173, B1174, B1175 DIAGNOSIS SENSOR UNIT

DTC Logic

INFOID:000000009649977

DTC DETECTION LOGIC

DTC	Display contents of CONSULT	DTC detecting condition	Possible cause
B1170 B1171 B1172 B1173 B1174 B1175	CONTROL UNIT	Air bag diagnosis sensor unit is malfunctioning	Malfunction in air bag diagnosis sensor unit

DTC CONFIRMATION PROCEDURE

1. CHECK SELF-DIAG RESULT

With CONSULT

1. Turn ignition switch ON.
2. Perform "Self Diagnostic Result" mode of "AIR BAG" using CONSULT.

Without CONSULT

1. Turn ignition switch ON.
2. Check the air bag warning lamp status. Refer to [SRC-15, "On Board Diagnosis Function"](#).

NOTE:

SRS does not enter the diagnosis mode if no malfunction is detected in the user mode.

Is malfunctioning part detected?

- YES >> Refer to [SRC-149, "Diagnosis Procedure"](#).
NO >> INSPECTION END

Diagnosis Procedure

INFOID:000000009649978

WARNING:

- Before servicing, turn ignition switch OFF, disconnect battery negative terminal, and wait at least 3 minutes or more. (To discharge backup capacitor.)
- Never use unspecified tester or other measuring device.

1. CHECK HARNESS CONNECTOR

Check the harness connector.

Is the inspection result normal?

- YES >> GO TO 2.
NO >> Replace harness connectors.

2. CHECK WIRING HARNESS

Check the wiring harness externals.

Is the inspection result normal?

- YES >> GO TO 3.
NO >> Replace wiring harness.

3. REPLACE AIR BAG DIAGNOSIS SENSOR UNIT

1. Replace air bag diagnosis sensor unit. Refer to [SR-29, "Removal and Installation"](#).
2. Perform DTC confirmation procedure. Refer to [SRC-149, "DTC Logic"](#).

Is DTC detected?

- YES >> GO TO 1.
NO >> INSPECTION END

B1186, B1187, B1188, B1189, B1190, B1191 DIAGNOSIS SENSOR UNIT

< DTC/CIRCUIT DIAGNOSIS >

B1186, B1187, B1188, B1189, B1190, B1191 DIAGNOSIS SENSOR UNIT

DTC Logic

INFOID:000000009649979

DTC DETECTION LOGIC

DTC	Display contents of CONSULT	DTC detecting condition	Possible cause
B1186 B1187 B1188 B1189 B1190 B1191	CONTROL UNIT	Air bag diagnosis sensor unit is malfunctioning	Malfunction in air bag diagnosis sensor unit

DTC CONFIRMATION PROCEDURE

1. CHECK SELF-DIAG RESULT

With CONSULT

1. Turn ignition switch ON.
2. Perform "Self Diagnostic Result" mode of "AIR BAG" using CONSULT.

Without CONSULT

1. Turn ignition switch ON.
2. Check the air bag warning lamp status. Refer to [SRC-15, "On Board Diagnosis Function"](#).

NOTE:

SRS does not enter the diagnosis mode if no malfunction is detected in the user mode.

Is malfunctioning part detected?

- YES >> Refer to [SRC-150, "Diagnosis Procedure"](#).
NO >> INSPECTION END

Diagnosis Procedure

INFOID:000000009649980

WARNING:

- Before servicing, turn ignition switch OFF, disconnect battery negative terminal, and wait at least 3 minutes or more. (To discharge backup capacitor.)
- Never use unspecified tester or other measuring device.

1. CHECK HARNESS CONNECTOR

Check the harness connector.

Is the inspection result normal?

- YES >> GO TO 2.
NO >> Replace harness connectors.

2. CHECK WIRING HARNESS

Check the wiring harness externals.

Is the inspection result normal?

- YES >> GO TO 3.
NO >> Replace wiring harness.

3. REPLACE AIR BAG DIAGNOSIS SENSOR UNIT

1. Replace air bag diagnosis sensor unit. Refer to [SR-29, "Removal and Installation"](#).
2. Perform DTC confirmation procedure. Refer to [SRC-150, "DTC Logic"](#).

Is DTC detected?

- YES >> GO TO 1.
NO >> INSPECTION END

B1193 CURTAIN AIR BAG MODULE RH

< DTC/CIRCUIT DIAGNOSIS >

B1193 CURTAIN AIR BAG MODULE RH

DTC Logic

INFOID:000000009649981

DTC DETECTION LOGIC

DTC	Display contents of CONSULT	DTC detecting condition	Possible cause
B1193	CURTAIN MODULE RH [OPEN]	Front curtain air bag module RH circuit is open	<ul style="list-style-type: none">• Disconnection of wiring harness and open• Malfunction in front curtain air bag module RH• Malfunction in air bag diagnosis sensor unit

DTC CONFIRMATION PROCEDURE

1. CHECK SELF-DIAG RESULT

With CONSULT

1. Turn ignition switch ON.
2. Perform "Self Diagnostic Result" mode of "AIR BAG" using CONSULT.

Without CONSULT

1. Turn ignition switch ON.
2. Check the air bag warning lamp status. Refer to [SRC-15. "On Board Diagnosis Function"](#).

NOTE:

SRS does not enter the diagnosis mode if no malfunction is detected in the user mode.

Is malfunctioning part detected?

- YES >> Refer to [SRC-151. "Diagnosis Procedure"](#).
NO >> INSPECTION END

Diagnosis Procedure

INFOID:000000009649982

WARNING:

- Before servicing, turn ignition switch OFF, disconnect battery negative terminal, and wait at least 3 minutes or more. (To discharge backup capacitor.)
- Never use unspecified tester or other measuring device.

1. CHECK HARNESS CONNECTOR

Check the harness connector.

Is the inspection result normal?

- YES >> GO TO 2.
NO >> Replace harness connector.

2. CHECK WIRING HARNESS

Check the wiring harness externals.

Is the inspection result normal?

- YES >> GO TO 3.
NO >> Replace wiring harness.

3. REPLACE AIR BAG DIAGNOSIS SENSOR UNIT

1. Replace air bag diagnosis sensor unit. Refer to [SR-29. "Removal and Installation"](#).
2. Perform DTC confirmation procedure. Refer to [SRC-151. "DTC Logic"](#).

Is DTC detected?

- YES >> GO TO 4.
NO >> INSPECTION END

4. REPLACE FRONT CURTAIN AIR BAG MODULE

1. Replace front curtain air bag module RH. Refer to [SR-21. "Removal and Installation"](#).
2. Perform DTC confirmation procedure. Refer to [SRC-151. "DTC Logic"](#).

Is DTC detected?

- YES >> GO TO 1.

B1193 CURTAIN AIR BAG MODULE RH

< DTC/CIRCUIT DIAGNOSIS >

NO >> INSPECTION END

B1194 CURTAIN AIR BAG MODULE RH

< DTC/CIRCUIT DIAGNOSIS >

B1194 CURTAIN AIR BAG MODULE RH

DTC Logic

INFOID:000000009649983

DTC DETECTION LOGIC

DTC	Display contents of CONSULT	DTC detecting condition	Possible cause
B1194	CURTAIN MODULE RH [VB-SHORT]	Front curtain air bag module RH circuit is shorted to power supply circuit	<ul style="list-style-type: none">• Disconnection of wiring harness and short• Malfunction in front curtain air bag module RH• Malfunction in air bag diagnosis sensor unit

DTC CONFIRMATION PROCEDURE

1. CHECK SELF-DIAG RESULT

With CONSULT

1. Turn ignition switch ON.
2. Perform "Self Diagnostic Result" mode of "AIR BAG" using CONSULT.

Without CONSULT

1. Turn ignition switch ON.
2. Check the air bag warning lamp status. Refer to [SRC-15. "On Board Diagnosis Function"](#).

NOTE:

SRS does not enter the diagnosis mode if no malfunction is detected in the user mode.

Is malfunctioning part detected?

- YES >> Refer to [SRC-153. "Diagnosis Procedure"](#).
NO >> INSPECTION END

Diagnosis Procedure

INFOID:000000009649984

WARNING:

- Before servicing, turn ignition switch OFF, disconnect battery negative terminal, and wait at least 3 minutes or more. (To discharge backup capacitor.)
- Never use unspecified tester or other measuring device.

1. CHECK HARNESS CONNECTOR

Check the harness connector.

Is the inspection result normal?

- YES >> GO TO 2.
NO >> Replace harness connector.

2. CHECK WIRING HARNESS

Check the wiring harness externals.

Is the inspection result normal?

- YES >> GO TO 3.
NO >> Replace wiring harness.

3. REPLACE AIR BAG DIAGNOSIS SENSOR UNIT

1. Replace air bag diagnosis sensor unit. Refer to [SR-29. "Removal and Installation"](#).
2. Perform DTC confirmation procedure. Refer to [SRC-153. "DTC Logic"](#).

Is DTC detected?

- YES >> GO TO 4.
NO >> INSPECTION END

4. REPLACE FRONT CURTAIN AIR BAG MODULE

1. Replace front curtain air bag module RH. Refer to [SR-21. "Removal and Installation"](#).
2. Perform DTC confirmation procedure. Refer to [SRC-153. "DTC Logic"](#).

Is DTC detected?

- YES >> GO TO 1.

B1194 CURTAIN AIR BAG MODULE RH

< DTC/CIRCUIT DIAGNOSIS >

NO >> INSPECTION END

B1195 CURTAIN AIR BAG MODULE RH

< DTC/CIRCUIT DIAGNOSIS >

B1195 CURTAIN AIR BAG MODULE RH

DTC Logic

INFOID:000000009649985

DTC DETECTION LOGIC

DTC	Display contents of CONSULT	DTC detecting condition	Possible cause
B1195	CURTAIN MODULE RH [GND-SHORT]	Front curtain air bag module RH circuit is shorted to ground	<ul style="list-style-type: none">• Disconnection of wiring harness and short• Malfunction in front curtain air bag module RH• Malfunction in air bag diagnosis sensor unit

DTC CONFIRMATION PROCEDURE

1.CHECK SELF-DIAG RESULT

With CONSULT

1. Turn ignition switch ON.
2. Perform "Self Diagnostic Result" mode of "AIR BAG" using CONSULT.

Without CONSULT

1. Turn ignition switch ON.
2. Check the air bag warning lamp status. Refer to [SRC-15, "On Board Diagnosis Function"](#).

NOTE:

SRS does not enter the diagnosis mode if no malfunction is detected in the user mode.

Is malfunctioning part detected?

- YES >> Refer to [SRC-155, "Diagnosis Procedure"](#).
NO >> INSPECTION END

Diagnosis Procedure

INFOID:000000009649986

WARNING:

- Before servicing, turn ignition switch OFF, disconnect battery negative terminal, and wait at least 3 minutes or more. (To discharge backup capacitor.)
- Never use unspecified tester or other measuring device.

1.CHECK HARNESS CONNECTOR

Check the harness connector.

Is the inspection result normal?

- YES >> GO TO 2.
NO >> Replace harness connector.

2.CHECK WIRING HARNESS

Check the wiring harness externals.

Is the inspection result normal?

- YES >> GO TO 3.
NO >> Replace wiring harness.

3.REPLACE AIR BAG DIAGNOSIS SENSOR UNIT

1. Replace air bag diagnosis sensor unit. Refer to [SR-29, "Removal and Installation"](#).
2. Perform DTC confirmation procedure. Refer to [SRC-155, "DTC Logic"](#).

Is DTC detected?

- YES >> GO TO 4.
NO >> INSPECTION END

4.REPLACE FRONT CURTAIN AIR BAG MODULE

1. Replace front curtain air bag module RH. Refer to [SR-21, "Removal and Installation"](#).
2. Perform DTC confirmation procedure. Refer to [SRC-155, "DTC Logic"](#).

Is DTC detected?

- YES >> GO TO 1.

B1195 CURTAIN AIR BAG MODULE RH

< DTC/CIRCUIT DIAGNOSIS >

NO >> INSPECTION END

B1196 CURTAIN AIR BAG MODULE RH

< DTC/CIRCUIT DIAGNOSIS >

B1196 CURTAIN AIR BAG MODULE RH

DTC Logic

INFOID:000000009649987

DTC DETECTION LOGIC

DTC	Display contents of CONSULT	DTC detecting condition	Possible cause
B1196	CURTAIN MODULE RH [SHORT]	Front curtain air bag module RH circuits are shorted to each other	<ul style="list-style-type: none">• Disconnection of wiring harness and short• Malfunction in front curtain air bag module RH• Malfunction in air bag diagnosis sensor unit

DTC CONFIRMATION PROCEDURE

1.CHECK SELF-DIAG RESULT

With CONSULT

1. Turn ignition switch ON.
2. Perform "Self Diagnostic Result" mode of "AIR BAG" using CONSULT.

Without CONSULT

1. Turn ignition switch ON.
2. Check the air bag warning lamp status. Refer to [SRC-15, "On Board Diagnosis Function"](#).

NOTE:

SRS does not enter the diagnosis mode if no malfunction is detected in the user mode.

Is malfunctioning part detected?

- YES >> Refer to [SRC-157, "Diagnosis Procedure"](#).
NO >> INSPECTION END

Diagnosis Procedure

INFOID:000000009649988

WARNING:

- Before servicing, turn ignition switch OFF, disconnect battery negative terminal, and wait at least 3 minutes or more. (To discharge backup capacitor.)
- Never use unspecified tester or other measuring device.

1.CHECK HARNESS CONNECTOR

Check the harness connector.

Is the inspection result normal?

- YES >> GO TO 2.
NO >> Replace harness connector.

2.CHECK WIRING HARNESS

Check the wiring harness externals.

Is the inspection result normal?

- YES >> GO TO 3.
NO >> Replace wiring harness.

3.REPLACE AIR BAG DIAGNOSIS SENSOR UNIT

1. Replace air bag diagnosis sensor unit. Refer to [SR-29, "Removal and Installation"](#).
2. Perform DTC confirmation procedure. Refer to [SRC-157, "DTC Logic"](#).

Is DTC detected?

- YES >> GO TO 4.
NO >> INSPECTION END

4.REPLACE FRONT CURTAIN AIR BAG MODULE

1. Replace front curtain air bag module RH. Refer to [SR-21, "Removal and Installation"](#).
2. Perform DTC confirmation procedure. Refer to [SRC-157, "DTC Logic"](#).

Is DTC detected?

- YES >> GO TO 1.

B1196 CURTAIN AIR BAG MODULE RH

< DTC/CIRCUIT DIAGNOSIS >

NO >> INSPECTION END

B1198 CURTAIN AIR BAG MODULE LH

< DTC/CIRCUIT DIAGNOSIS >

B1198 CURTAIN AIR BAG MODULE LH

DTC Logic

INFOID:000000009649989

DTC DETECTION LOGIC

DTC	Display contents of CONSULT	DTC detecting condition	Possible cause
B1198	CURTAIN MODULE LH [OPEN]	Front curtain air bag module LH circuit is open	<ul style="list-style-type: none">• Disconnection of wiring harness and open• Malfunction in front curtain air bag module LH• Malfunction in air bag diagnosis sensor unit

DTC CONFIRMATION PROCEDURE

1. CHECK SELF-DIAG RESULT

With CONSULT

1. Turn ignition switch ON.
2. Perform "Self Diagnostic Result" mode of "AIR BAG" using CONSULT.

Without CONSULT

1. Turn ignition switch ON.
2. Check the air bag warning lamp status. Refer to [SRC-15. "On Board Diagnosis Function"](#).

NOTE:

SRS does not enter the diagnosis mode if no malfunction is detected in the user mode.

Is malfunctioning part detected?

- YES >> Refer to [SRC-159. "Diagnosis Procedure"](#).
NO >> INSPECTION END

Diagnosis Procedure

INFOID:000000009649990

WARNING:

- Before servicing, turn ignition switch OFF, disconnect battery negative terminal, and wait at least 3 minutes or more. (To discharge backup capacitor.)
- Never use unspecified tester or other measuring device.

1. CHECK HARNESS CONNECTOR

Check the harness connector.

Is the inspection result normal?

- YES >> GO TO 2.
NO >> Replace harness connector.

2. CHECK WIRING HARNESS

Check the wiring harness externals.

Is the inspection result normal?

- YES >> GO TO 3.
NO >> Replace wiring harness.

3. REPLACE AIR BAG DIAGNOSIS SENSOR UNIT

1. Replace air bag diagnosis sensor unit. Refer to [SR-29. "Removal and Installation"](#).
2. Perform DTC confirmation procedure. Refer to [SRC-159. "DTC Logic"](#).

Is DTC detected?

- YES >> GO TO 4.
NO >> INSPECTION END

4. REPLACE FRONT CURTAIN AIR BAG MODULE

1. Replace front curtain air bag module LH. Refer to [SR-21. "Removal and Installation"](#).
2. Perform DTC confirmation procedure. Refer to [SRC-159. "DTC Logic"](#).

Is DTC detected?

- YES >> GO TO 1.

B1198 CURTAIN AIR BAG MODULE LH

< DTC/CIRCUIT DIAGNOSIS >

NO >> INSPECTION END

B1199 CURTAIN AIR BAG MODULE LH

< DTC/CIRCUIT DIAGNOSIS >

B1199 CURTAIN AIR BAG MODULE LH

DTC Logic

INFOID:000000009649991

DTC DETECTION LOGIC

DTC	Display contents of CONSULT	DTC detecting condition	Possible cause
B1199	CURTAIN MODULE LH [VB-SHORT]	Front curtain air bag module LH circuit is shorted to power supply circuit	<ul style="list-style-type: none">• Disconnection of wiring harness and short• Malfunction in front curtain air bag module LH• Malfunction in air bag diagnosis sensor unit

DTC CONFIRMATION PROCEDURE

1.CHECK SELF-DIAG RESULT

With CONSULT

1. Turn ignition switch ON.
2. Perform "Self Diagnostic Result" mode of "AIR BAG" using CONSULT.

Without CONSULT

1. Turn ignition switch ON.
2. Check the air bag warning lamp status. Refer to [SRC-15, "On Board Diagnosis Function"](#).

NOTE:

SRS does not enter the diagnosis mode if no malfunction is detected in the user mode.

Is malfunctioning part detected?

- YES >> Refer to [SRC-161, "Diagnosis Procedure"](#).
NO >> INSPECTION END

Diagnosis Procedure

INFOID:000000009649992

WARNING:

- Before servicing, turn ignition switch OFF, disconnect battery negative terminal, and wait at least 3 minutes or more. (To discharge backup capacitor.)
- Never use unspecified tester or other measuring device.

1.CHECK HARNESS CONNECTOR

Check the harness connector.

Is the inspection result normal?

- YES >> GO TO 2.
NO >> Replace harness connector.

2.CHECK WIRING HARNESS

Check the wiring harness externals.

Is the inspection result normal?

- YES >> GO TO 3.
NO >> Replace wiring harness.

3.REPLACE AIR BAG DIAGNOSIS SENSOR UNIT

1. Replace air bag diagnosis sensor unit. Refer to [SR-21, "Removal and Installation"](#).
2. Perform DTC confirmation procedure. Refer to [SRC-161, "DTC Logic"](#).

Is DTC detected?

- YES >> GO TO 4.
NO >> INSPECTION END

4.REPLACE FRONT CURTAIN AIR BAG MODULE

1. Replace front curtain air bag module LH. Refer to [SR-21, "Removal and Installation"](#).
2. Perform DTC confirmation procedure. Refer to [SRC-161, "DTC Logic"](#).

Is DTC detected?

- YES >> GO TO 1.

B1199 CURTAIN AIR BAG MODULE LH

< DTC/CIRCUIT DIAGNOSIS >

NO >> INSPECTION END

B1200 CURTAIN AIR BAG MODULE LH

< DTC/CIRCUIT DIAGNOSIS >

B1200 CURTAIN AIR BAG MODULE LH

DTC Logic

INFOID:000000009649993

DTC DETECTION LOGIC

DTC	Display contents of CONSULT	DTC detecting condition	Possible cause
B1200	CURTAIN MODULE LH [GND-SHORT]	Front curtain air bag module LH circuit is shorted to ground	<ul style="list-style-type: none">• Disconnection of wiring harness and short• Malfunction in front curtain air bag module LH• Malfunction in air bag diagnosis sensor unit

DTC CONFIRMATION PROCEDURE

1.CHECK SELF-DIAG RESULT

With CONSULT

1. Turn ignition switch ON.
2. Perform "Self Diagnostic Result" mode of "AIR BAG" using CONSULT.

Without CONSULT

1. Turn ignition switch ON.
2. Check the air bag warning lamp status. Refer to [SRC-15, "On Board Diagnosis Function"](#).

NOTE:

SRS does not enter the diagnosis mode if no malfunction is detected in the user mode.

Is malfunctioning part detected?

- YES >> Refer to [SRC-163, "Diagnosis Procedure"](#).
NO >> INSPECTION END

Diagnosis Procedure

INFOID:000000009649994

WARNING:

- Before servicing, turn ignition switch OFF, disconnect battery negative terminal, and wait at least 3 minutes or more. (To discharge backup capacitor.)
- Never use unspecified tester or other measuring device.

1.CHECK HARNESS CONNECTOR

Check the harness connector.

Is the inspection result normal?

- YES >> GO TO 2.
NO >> Replace harness connector.

2.CHECK WIRING HARNESS

Check the wiring harness externals.

Is the inspection result normal?

- YES >> GO TO 3.
NO >> Replace wiring harness.

3.REPLACE AIR BAG DIAGNOSIS SENSOR UNIT

1. Replace air bag diagnosis sensor unit. Refer to [SR-29, "Removal and Installation"](#).
2. Perform DTC confirmation procedure. Refer to [SRC-163, "DTC Logic"](#).

Is DTC detected?

- YES >> GO TO 4.
NO >> INSPECTION END

4.REPLACE FRONT CURTAIN AIR BAG MODULE

1. Replace front curtain air bag module LH. Refer to [SR-21, "Removal and Installation"](#).
2. Perform DTC confirmation procedure. Refer to [SRC-163, "DTC Logic"](#).

Is DTC detected?

- YES >> GO TO 1.

B1200 CURTAIN AIR BAG MODULE LH

< DTC/CIRCUIT DIAGNOSIS >

NO >> INSPECTION END

B1201 CURTAIN AIR BAG MODULE LH

< DTC/CIRCUIT DIAGNOSIS >

B1201 CURTAIN AIR BAG MODULE LH

DTC Logic

INFOID:000000009649995

DTC DETECTION LOGIC

DTC	Display contents of CONSULT	DTC detecting condition	Possible cause
B1201	CURTAIN MODULE LH [SHORT]	Front curtain air bag module LH circuits are shorted to each other	<ul style="list-style-type: none">• Disconnection of wiring harness and short• Malfunction in front curtain air bag module LH• Malfunction in air bag diagnosis sensor unit

DTC CONFIRMATION PROCEDURE

1. CHECK SELF-DIAG RESULT

With CONSULT

1. Turn ignition switch ON.
2. Perform "Self Diagnostic Result" mode of "AIR BAG" using CONSULT.

Without CONSULT

1. Turn ignition switch ON.
2. Check the air bag warning lamp status. Refer to [SRC-15, "On Board Diagnosis Function"](#).

NOTE:

SRS does not enter the diagnosis mode if no malfunction is detected in the user mode.

Is malfunctioning part detected?

- YES >> Refer to [SRC-165, "Diagnosis Procedure"](#).
NO >> INSPECTION END

Diagnosis Procedure

INFOID:000000009649996

WARNING:

- Before servicing, turn ignition switch OFF, disconnect battery negative terminal, and wait at least 3 minutes or more. (To discharge backup capacitor.)
- Never use unspecified tester or other measuring device.

1. CHECK HARNESS CONNECTOR

Check the harness connector.

Is the inspection result normal?

- YES >> GO TO 2.
NO >> Replace harness connector.

2. CHECK WIRING HARNESS

Check the wiring harness externals.

Is the inspection result normal?

- YES >> GO TO 3.
NO >> Replace wiring harness.

3. REPLACE AIR BAG DIAGNOSIS SENSOR UNIT

1. Replace air bag diagnosis sensor unit. Refer to [SR-29, "Removal and Installation"](#).
2. Perform DTC confirmation procedure. Refer to [SRC-165, "DTC Logic"](#).

Is DTC detected?

- YES >> GO TO 4.
NO >> INSPECTION END

4. REPLACE FRONT CURTAIN AIR BAG MODULE

1. Replace front curtain air bag module LH. Refer to [SR-21, "Removal and Installation"](#).
2. Perform DTC confirmation procedure. Refer to [SRC-165, "DTC Logic"](#).

Is DTC detected?

- YES >> GO TO 1.

B1201 CURTAIN AIR BAG MODULE LH

< DTC/CIRCUIT DIAGNOSIS >

NO >> INSPECTION END

B1202, B1203, B1204, B1205, B1206, B1207 DIAGNOSIS SENSOR UNIT

< DTC/CIRCUIT DIAGNOSIS >

B1202, B1203, B1204, B1205, B1206, B1207 DIAGNOSIS SENSOR UNIT

DTC Logic

INFOID:000000009649997

DTC DETECTION LOGIC

DTC	Display contents of CONSULT	DTC detecting condition	Possible cause
B1202 B1203 B1204 B1205 B1206 B1207	CONTROL UNIT	Air bag diagnosis sensor unit is malfunctioning	Malfunction in air bag diagnosis sensor unit

DTC CONFIRMATION PROCEDURE

1. CHECK SELF-DIAG RESULT

With CONSULT

1. Turn ignition switch ON.
2. Perform "Self Diagnostic Result" mode of "AIR BAG" using CONSULT.

Without CONSULT

1. Turn ignition switch ON.
2. Check the air bag warning lamp status. Refer to [SRC-15, "On Board Diagnosis Function"](#).

NOTE:

SRS does not enter the diagnosis mode if no malfunction is detected in the user mode.

Is malfunctioning part detected?

- YES >> Refer to [SRC-167, "Diagnosis Procedure"](#).
NO >> INSPECTION END

Diagnosis Procedure

INFOID:000000009649998

WARNING:

- Before servicing, turn ignition switch OFF, disconnect battery negative terminal, and wait at least 3 minutes or more. (To discharge backup capacitor.)
- Never use unspecified tester or other measuring device.

1. CHECK HARNESS CONNECTOR

Check the harness connector.

Is the inspection result normal?

- YES >> GO TO 2.
NO >> Replace harness connectors.

2. CHECK WIRING HARNESS

Check the wiring harness externals.

Is the inspection result normal?

- YES >> GO TO 3.
NO >> Replace wiring harness.

3. REPLACE AIR BAG DIAGNOSIS SENSOR UNIT

1. Replace air bag diagnosis sensor unit. Refer to [SR-29, "Removal and Installation"](#).
2. Perform DTC confirmation procedure. Refer to [SRC-167, "DTC Logic"](#).

Is DTC detected?

- YES >> GO TO 1.
NO >> INSPECTION END

B1209 FRONTAL COLLISION DETECTION

< DTC/CIRCUIT DIAGNOSIS >

B1209 FRONTAL COLLISION DETECTION

Description

INFOID:000000009649999

The air bags and seat belt pre-tensioners for driver and passenger are activated by the air bag diagnosis sensor unit signal transmitted at the time of the frontal collision.

DTC Logic

INFOID:000000009650000

DTC DETECTION LOGIC

DTC	Display contents of CONSULT	DTC detecting condition	Possible cause
B1209	FRONTAL COLLISION DETECTION	Seat belt pre-tensioner, driver side air bag and passenger air bag are deployed	—

DTC CONFIRMATION PROCEDURE

1. CHECK SELF-DIAG RESULT

With CONSULT

1. Turn ignition switch ON.
2. Perform "Self Diagnostic Result" mode of "AIR BAG" using CONSULT.

Without CONSULT

1. Turn ignition switch ON.
2. Check the air bag warning lamp status. Refer to [SRC-15, "On Board Diagnosis Function"](#).

NOTE:

SRS does not enter the diagnosis mode if no malfunction is detected in the user mode.

Is malfunctioning part detected?

- YES >> Refer to [SRC-168, "Diagnosis Procedure"](#).
NO >> INSPECTION END

Diagnosis Procedure

INFOID:000000009650001

WARNING:

- Before servicing, turn ignition switch OFF, disconnect battery negative terminal, and wait at least 3 minutes or more. (To discharge backup capacitor.)
- Never use unspecified tester or other measuring device.

1. PERFORM COLLISION DIAGNOSIS

Perform collision diagnosis. Refer to [SR-5, "FOR FRONTAL COLLISION : When SRS is activated in a collision"](#) or [SR-6, "FOR FRONTAL COLLISION : When SRS is not activated in a collision"](#).

>> GO TO 2.

2. FINAL INSPECTION

Perform "AIR BAG" Self Diagnostic Result.

Is the inspection result normal?

- YES >> INSPECTION END
NO >> Perform diagnosis of applicable DTC. Refer to [SRC-22, "DTC Index"](#).

B1210 SIDE COLLISION DETECTION

< DTC/CIRCUIT DIAGNOSIS >

B1210 SIDE COLLISION DETECTION

Description

INFOID:000000009650002

The side air bag and curtain air bag are activated by the air bag diagnosis sensor unit signal transmitted at the time of side collision.

DTC Logic

INFOID:000000009650003

DTC DETECTION LOGIC

DTC	Display contents of CONSULT	DTC detecting condition	Possible cause
B1210	SIDE COLLISION DETECTION	Side air bag and curtain air bag are deployed	—

DTC CONFIRMATION PROCEDURE

1. CHECK SELF-DIAG RESULT

With CONSULT

1. Turn ignition switch ON.
2. Perform "Self Diagnostic Result" mode of "AIR BAG" using CONSULT.

Without CONSULT

1. Turn ignition switch ON.
2. Check the air bag warning lamp status. Refer to [SRC-15, "On Board Diagnosis Function"](#).

NOTE:

SRS does not enter the diagnosis mode if no malfunction is detected in the user mode.

Is malfunctioning part detected?

- YES >> Refer to [SRC-169, "Diagnosis Procedure"](#).
NO >> INSPECTION END

Diagnosis Procedure

INFOID:000000009650004

WARNING:

- Before servicing, turn ignition switch OFF, disconnect battery negative terminal, and wait at least 3 minutes or more. (To discharge backup capacitor.)
- Never use unspecified tester or other measuring device.

1. PERFORM COLLISION DIAGNOSIS

Perform collision diagnosis. Refer to [SR-7, "FOR SIDE AND ROLLOVER COLLISION : When SRS is activated in a collision"](#) or [SR-8, "FOR SIDE AND ROLLOVER COLLISION : When SRS is not activated in a collision"](#).

>> GO TO 2.

2. FINAL INSPECTION

Perform "AIR BAG" Self Diagnostic Result.

Is the inspection result normal?

- YES >> INSPECTION END
NO >> Perform diagnosis of applicable DTC. Refer to [SRC-22, "DTC Index"](#).

B1212, B1213, B1214 SATELLITE SENSOR RH

< DTC/CIRCUIT DIAGNOSIS >

B1212, B1213, B1214 SATELLITE SENSOR RH

DTC Logic

INFOID:000000009650005

DTC DETECTION LOGIC

DTC	Display contents of CONSULT	DTC detecting condition	Possible cause
B1212 B1213 B1214	RH1 SAT-SENS	Front satellite sensor RH is malfunctioning	<ul style="list-style-type: none">• Disconnection of wiring harness• Malfunction in front satellite sensor RH• Malfunction in air bag diagnosis sensor unit

DTC CONFIRMATION PROCEDURE

1. CHECK SELF-DIAG RESULT

With CONSULT

1. Turn ignition switch ON.
2. Perform "Self Diagnostic Result" mode of "AIR BAG" using CONSULT.

Without CONSULT

1. Turn ignition switch ON.
2. Check the air bag warning lamp status. Refer to [SRC-15, "On Board Diagnosis Function"](#).

NOTE:

SRS does not enter the diagnosis mode if no malfunction is detected in the user mode.

Is malfunctioning part detected?

- YES >> Refer to [SRC-170, "Diagnosis Procedure"](#).
NO >> INSPECTION END

Diagnosis Procedure

INFOID:000000009650006

WARNING:

- Before servicing, turn ignition switch OFF, disconnect battery negative terminal, and wait at least 3 minutes or more. (To discharge backup capacitor.)
- Never use unspecified tester or other measuring device.

1. CHECK HARNESS CONNECTOR

Check the harness connector.

Is the inspection result normal?

- YES >> GO TO 2.
NO >> Replace harness connector.

2. CHECK WIRING HARNESS

Check the wiring harness externals.

Is the inspection result normal?

- YES >> GO TO 3.
NO >> Replace wiring harness.

3. REPLACE FRONT SATELLITE SENSOR

1. Replace front satellite sensor RH. Refer to [SR-26, "Removal and Installation"](#).
2. Perform DTC confirmation procedure. Refer to [SRC-170, "DTC Logic"](#).

Is DTC detected?

- YES >> GO TO 4.
NO >> INSPECTION END

4. REPLACE AIR BAG DIAGNOSIS SENSOR UNIT

1. Replace air bag diagnosis sensor unit. Refer to [SR-29, "Removal and Installation"](#).
2. Perform DTC confirmation procedure. Refer to [SRC-170, "DTC Logic"](#).

Is DTC detected?

- YES >> GO TO 1.

B1212, B1213, B1214 SATELLITE SENSOR RH

< DTC/CIRCUIT DIAGNOSIS >

NO >> INSPECTION END

A

B

C

D

E

F

G

SRC

I

J

K

L

M

N

O

P

B1215, B1216, B1217 SATELLITE SENSOR LH

< DTC/CIRCUIT DIAGNOSIS >

B1215, B1216, B1217 SATELLITE SENSOR LH

DTC Logic

INFOID:000000009650007

DTC DETECTION LOGIC

DTC	Display contents of CONSULT	DTC detecting condition	Possible cause
B1215 B1216 B1217	LH1 SAT-SENS	Front satellite sensor LH is malfunctioning	<ul style="list-style-type: none">• Disconnection of wiring harness• Malfunction in front satellite sensor LH• Malfunction in air bag diagnosis sensor unit

DTC CONFIRMATION PROCEDURE

1. CHECK SELF-DIAG RESULT

With CONSULT

1. Turn ignition switch ON.
2. Perform "Self Diagnostic Result" mode of "AIR BAG" using CONSULT.

Without CONSULT

1. Turn ignition switch ON.
2. Check the air bag warning lamp status. Refer to [SRC-15, "On Board Diagnosis Function"](#).

NOTE:

SRS does not enter the diagnosis mode if no malfunction is detected in the user mode.

Is malfunctioning part detected?

- YES >> Refer to [SRC-172, "Diagnosis Procedure"](#).
NO >> INSPECTION END

Diagnosis Procedure

INFOID:000000009650008

WARNING:

- Before servicing, turn ignition switch OFF, disconnect battery negative terminal, and wait at least 3 minutes or more. (To discharge backup capacitor.)
- Never use unspecified tester or other measuring device.

1. CHECK HARNESS CONNECTOR

Check the harness connector.

Is the inspection result normal?

- YES >> GO TO 2.
NO >> Replace harness connector.

2. CHECK WIRING HARNESS

Check the wiring harness externals.

Is the inspection result normal?

- YES >> GO TO 3.
NO >> Replace wiring harness.

3. REPLACE FRONT SATELLITE SENSOR

1. Replace front satellite sensor LH. Refer to [SR-26, "Removal and Installation"](#).
2. Perform DTC confirmation procedure. Refer to [SRC-172, "DTC Logic"](#).

Is DTC detected?

- YES >> GO TO 4.
NO >> INSPECTION END

4. REPLACE AIR BAG DIAGNOSIS SENSOR UNIT

1. Replace air bag diagnosis sensor unit. Refer to [SR-29, "Removal and Installation"](#).
2. Perform DTC confirmation procedure. Refer to [SRC-172, "DTC Logic"](#).

Is DTC detected?

- YES >> GO TO 1.

B1215, B1216, B1217 SATELLITE SENSOR LH

< DTC/CIRCUIT DIAGNOSIS >

NO >> INSPECTION END

A

B

C

D

E

F

G

SRC

I

J

K

L

M

N

O

P

B1218, B1219, B1220, B1221, B1222, B1223 DIAGNOSIS SENSOR UNIT

< DTC/CIRCUIT DIAGNOSIS >

B1218, B1219, B1220, B1221, B1222, B1223 DIAGNOSIS SENSOR UNIT

DTC Logic

INFOID:00000000965009

DTC DETECTION LOGIC

DTC	Display contents of CONSULT	DTC detecting condition	Possible cause
B1218 B1219 B1220 B1221 B1222 B1223	CONTROL UNIT	Air bag diagnosis sensor unit is malfunctioning	Malfunction in air bag diagnosis sensor unit

DTC CONFIRMATION PROCEDURE

1.CHECK SELF-DIAG RESULT

With CONSULT

1. Turn ignition switch ON.
2. Perform "Self Diagnostic Result" mode of "AIR BAG" using CONSULT.

Without CONSULT

1. Turn ignition switch ON.
2. Check the air bag warning lamp status. Refer to [SRC-15, "On Board Diagnosis Function"](#).

NOTE:

SRS does not enter the diagnosis mode if no malfunction is detected in the user mode.

Is malfunctioning part detected?

- YES >> Refer to [SRC-174, "Diagnosis Procedure"](#).
NO >> INSPECTION END

Diagnosis Procedure

INFOID:000000009650010

WARNING:

- Before servicing, turn ignition switch OFF, disconnect battery negative terminal, and wait at least 3 minutes or more. (To discharge backup capacitor.)
- Never use unspecified tester or other measuring device.

1.CHECK HARNESS CONNECTOR

Check the harness connector.

Is the inspection result normal?

- YES >> GO TO 2.
NO >> Replace harness connectors.

2.CHECK WIRING HARNESS

Check the wiring harness externals.

Is the inspection result normal?

- YES >> GO TO 3.
NO >> Replace wiring harness.

3.REPLACE AIR BAG DIAGNOSIS SENSOR UNIT

1. Replace air bag diagnosis sensor unit. Refer to [SR-29, "Removal and Installation"](#).
2. Perform DTC confirmation procedure. Refer to [SRC-174, "DTC Logic"](#).

Is DTC detected?

- YES >> GO TO 1.
NO >> INSPECTION END

B1234, B1235, B1236, B1237, B1238, B1239 DIAGNOSIS SENSOR UNIT

< DTC/CIRCUIT DIAGNOSIS >

B1234, B1235, B1236, B1237, B1238, B1239 DIAGNOSIS SENSOR UNIT

DTC Logic

INFOID:000000009650011

DTC DETECTION LOGIC

DTC	Display contents of CONSULT	DTC detecting condition	Possible cause
B1234 B1235 B1236 B1237 B1238 B1239	CONTROL UNIT	Air bag diagnosis sensor unit is malfunctioning	Malfunction in air bag diagnosis sensor unit

DTC CONFIRMATION PROCEDURE

1. CHECK SELF-DIAG RESULT

With CONSULT

1. Turn ignition switch ON.
2. Perform "Self Diagnostic Result" mode of "AIR BAG" using CONSULT.

Without CONSULT

1. Turn ignition switch ON.
2. Check the air bag warning lamp status. Refer to [SRC-15, "On Board Diagnosis Function"](#).

NOTE:

SRS does not enter the diagnosis mode if no malfunction is detected in the user mode.

Is malfunctioning part detected?

- YES >> Refer to [SRC-175, "Diagnosis Procedure"](#).
NO >> INSPECTION END

Diagnosis Procedure

INFOID:000000009650012

WARNING:

- Before servicing, turn ignition switch OFF, disconnect battery negative terminal, and wait at least 3 minutes or more. (To discharge backup capacitor.)
- Never use unspecified tester or other measuring device.

1. CHECK HARNESS CONNECTOR

Check the harness connector.

Is the inspection result normal?

- YES >> GO TO 2.
NO >> Replace harness connectors.

2. CHECK WIRING HARNESS

Check the wiring harness externals.

Is the inspection result normal?

- YES >> GO TO 3.
NO >> Replace wiring harness.

3. REPLACE AIR BAG DIAGNOSIS SENSOR UNIT

1. Replace air bag diagnosis sensor unit. Refer to [SR-29, "Removal and Installation"](#).
2. Perform DTC confirmation procedure. Refer to [SRC-175, "DTC Logic"](#).

Is DTC detected?

- YES >> GO TO 1.
NO >> INSPECTION END

B1250, B1251, B1252, B1253, B1254, B1255 DIAGNOSIS SENSOR UNIT

< DTC/CIRCUIT DIAGNOSIS >

B1250, B1251, B1252, B1253, B1254, B1255 DIAGNOSIS SENSOR UNIT

DTC Logic

INFOID:000000009650013

DTC DETECTION LOGIC

DTC	Display contents of CONSULT	DTC detecting condition	Possible cause
B1250 B1251 B1252 B1253 B1254 B1255	CONTROL UNIT	Air bag diagnosis sensor unit is malfunctioning	Malfunction in air bag diagnosis sensor unit

DTC CONFIRMATION PROCEDURE

1. CHECK SELF-DIAG RESULT

With CONSULT

1. Turn ignition switch ON.
2. Perform "Self Diagnostic Result" mode of "AIR BAG" using CONSULT.

Without CONSULT

1. Turn ignition switch ON.
2. Check the air bag warning lamp status. Refer to [SRC-15, "On Board Diagnosis Function"](#).

NOTE:

SRS does not enter the diagnosis mode if no malfunction is detected in the user mode.

Is malfunctioning part detected?

- YES >> Refer to [SRC-176, "Diagnosis Procedure"](#).
NO >> INSPECTION END

Diagnosis Procedure

INFOID:000000009650014

WARNING:

- Before servicing, turn ignition switch OFF, disconnect battery negative terminal, and wait at least 3 minutes or more. (To discharge backup capacitor.)
- Never use unspecified tester or other measuring device.

1. CHECK HARNESS CONNECTOR

Check the harness connector.

Is the inspection result normal?

- YES >> GO TO 2.
NO >> Replace harness connectors.

2. CHECK WIRING HARNESS

Check the wiring harness externals.

Is the inspection result normal?

- YES >> GO TO 3.
NO >> Replace wiring harness.

3. REPLACE AIR BAG DIAGNOSIS SENSOR UNIT

1. Replace air bag diagnosis sensor unit. Refer to [SR-29, "Removal and Installation"](#).
2. Perform DTC confirmation procedure. Refer to [SRC-176, "DTC Logic"](#).

Is DTC detected?

- YES >> GO TO 1.
NO >> INSPECTION END

B1266, B1267, B1268, B1269 DIAGNOSIS SENSOR UNIT

< DTC/CIRCUIT DIAGNOSIS >

B1266, B1267, B1268, B1269 DIAGNOSIS SENSOR UNIT

DTC Logic

INFOID:000000009650015

DTC DETECTION LOGIC

DTC	Display contents of CONSULT	DTC detecting condition	Possible cause
B1266 B1267 B1268 B1269	CONTROL UNIT	Air bag diagnosis sensor unit is malfunctioning	Malfunction in air bag diagnosis sensor unit

DTC CONFIRMATION PROCEDURE

1. CHECK SELF-DIAG RESULT

With CONSULT

1. Turn ignition switch ON.
2. Perform "Self Diagnostic Result" mode of "AIR BAG" using CONSULT.

Without CONSULT

1. Turn ignition switch ON.
2. Check the air bag warning lamp status. Refer to [SRC-15, "On Board Diagnosis Function"](#).

NOTE:

SRS does not enter the diagnosis mode if no malfunction is detected in the user mode.

Is malfunctioning part detected?

- YES >> Refer to [SRC-200, "Diagnosis Procedure"](#).
NO >> INSPECTION END

Diagnosis Procedure

INFOID:000000009650016

WARNING:

- Before servicing, turn ignition switch OFF, disconnect battery negative terminal, and wait at least 3 minutes or more. (To discharge backup capacitor.)
- Never use unspecified tester or other measuring device.

1. CHECK HARNESS CONNECTOR

Check the harness connector.

Is the inspection result normal?

- YES >> GO TO 2.
NO >> Replace harness connectors.

2. CHECK WIRING HARNESS

Check the wiring harness externals.

Is the inspection result normal?

- YES >> GO TO 3.
NO >> Replace wiring harness.

3. REPLACE AIR BAG DIAGNOSIS SENSOR UNIT

1. Replace air bag diagnosis sensor unit. Refer to [SR-29, "Removal and Installation"](#).
2. Perform DTC confirmation procedure. Refer to [SRC-200, "DTC Logic"](#).

Is DTC detected?

- YES >> GO TO 1.
NO >> INSPECTION END

B1282, B1283, B1284, B1285 DIAGNOSIS SENSOR UNIT

< DTC/CIRCUIT DIAGNOSIS >

B1282, B1283, B1284, B1285 DIAGNOSIS SENSOR UNIT

DTC Logic

INFOID:000000009650017

DTC DETECTION LOGIC

DTC	Display contents of CONSULT	DTC detecting condition	Possible cause
B1282 B1283 B1284 B1285	CONTROL UNIT	Air bag diagnosis sensor unit is malfunctioning	Malfunction in air bag diagnosis sensor unit

DTC CONFIRMATION PROCEDURE

1. CHECK SELF-DIAG RESULT

With CONSULT

1. Turn ignition switch ON.
2. Perform "Self Diagnostic Result" mode of "AIR BAG" using CONSULT.

Without CONSULT

1. Turn ignition switch ON.
2. Check the air bag warning lamp status. Refer to [SRC-15, "On Board Diagnosis Function"](#).

NOTE:

SRS does not enter the diagnosis mode if no malfunction is detected in the user mode.

Is malfunctioning part detected?

- YES >> Refer to [SRC-200, "Diagnosis Procedure"](#).
NO >> INSPECTION END

Diagnosis Procedure

INFOID:000000009650018

WARNING:

- Before servicing, turn ignition switch OFF, disconnect battery negative terminal, and wait at least 3 minutes or more. (To discharge backup capacitor.)
- Never use unspecified tester or other measuring device.

1. CHECK HARNESS CONNECTOR

Check the harness connector.

Is the inspection result normal?

- YES >> GO TO 2.
NO >> Replace harness connectors.

2. CHECK WIRING HARNESS

Check the wiring harness externals.

Is the inspection result normal?

- YES >> GO TO 3.
NO >> Replace wiring harness.

3. REPLACE AIR BAG DIAGNOSIS SENSOR UNIT

1. Replace air bag diagnosis sensor unit. Refer to [SR-29, "Removal and Installation"](#).
2. Perform DTC confirmation procedure. Refer to [SRC-200, "DTC Logic"](#).

Is DTC detected?

- YES >> GO TO 1.
NO >> INSPECTION END

B1304 SATELLITE SEN RH

< DTC/CIRCUIT DIAGNOSIS >

B1304 SATELLITE SEN RH

DTC Logic

INFOID:000000009650019

DTC DETECTION LOGIC

DTC	Display contents of CONSULT	DTC detecting condition	Possible cause
B1304	SATELLITE SENS RH [UNIT FAIL]	Rear satellite sensor RH is malfunctioning	<ul style="list-style-type: none">• Disconnection of wiring harness• Malfunction in rear satellite sensor RH• Malfunction in air bag diagnosis sensor unit

DTC CONFIRMATION PROCEDURE

1.CHECK SELF-DIAG RESULT

With CONSULT

1. Turn ignition switch ON.
2. Perform "Self Diagnostic Result" mode of "AIR BAG" using CONSULT.

Without CONSULT

1. Turn ignition switch ON.
2. Check the air bag warning lamp status. Refer to [SRC-15, "On Board Diagnosis Function"](#).

NOTE:

SRS does not enter the diagnosis mode if no malfunction is detected in the user mode.

Is malfunctioning part detected?

- YES >> Refer to [SRC-179, "Diagnosis Procedure"](#).
NO >> INSPECTION END

Diagnosis Procedure

INFOID:000000009650020

WARNING:

- Before servicing, turn ignition switch OFF, disconnect battery negative terminal, and wait at least 3 minutes or more. (To discharge backup capacitor.)
- Never use unspecified tester or other measuring device.

1.CHECK HARNESS CONNECTOR

Check the harness connector.

Is the inspection result normal?

- YES >> GO TO 2.
NO >> Replace harness connector.

2.CHECK WIRING HARNESS

Check the wiring harness externals.

Is the inspection result normal?

- YES >> GO TO 3.
NO >> Replace wiring harness.

3.REPLACE REAR SATELLITE SENSOR

1. Replace rear satellite sensor RH. Refer to [SR-26, "Removal and Installation"](#).
2. Perform DTC confirmation procedure. Refer to [SRC-179, "DTC Logic"](#).

Is DTC detected?

- YES >> GO TO 4.
NO >> INSPECTION END

4.REPLACE AIR BAG DIAGNOSIS SENSOR UNIT

1. Replace air bag diagnosis sensor unit. Refer to [SR-29, "Removal and Installation"](#).
2. Perform DTC confirmation procedure. Refer to [SRC-179, "DTC Logic"](#).

Is DTC detected?

- YES >> GO TO 1.

B1304 SATELLITE SEN RH

< DTC/CIRCUIT DIAGNOSIS >

NO >> INSPECTION END

B1306, B1308, B1309, B1310 SATELLITE SEN RH

< DTC/CIRCUIT DIAGNOSIS >

B1306, B1308, B1309, B1310 SATELLITE SEN RH

DTC Logic

INFOID:000000009650021

DTC DETECTION LOGIC

DTC	Display contents of CONSULT	DTC detecting condition	Possible cause
B1306 B1308 B1309 B1310	SATELLITE SENS RH [COMM FAIL]	Rear satellite sensor RH is malfunctioning or out of the specified specification	<ul style="list-style-type: none">Disconnection of wiring harnessMalfunction in rear satellite sensor RHMalfunction in air bag diagnosis sensor unit

DTC CONFIRMATION PROCEDURE

1. CHECK SELF-DIAG RESULT

With CONSULT

- Turn ignition switch ON.
- Perform "Self Diagnostic Result" mode of "AIR BAG" using CONSULT.

Without CONSULT

- Turn ignition switch ON.
- Check the air bag warning lamp status. Refer to [SRC-15, "On Board Diagnosis Function"](#).

NOTE:

SRS does not enter the diagnosis mode if no malfunction is detected in the user mode.

Is malfunctioning part detected?

- YES >> Refer to [SRC-181, "Diagnosis Procedure"](#).
NO >> INSPECTION END

Diagnosis Procedure

INFOID:000000009650022

WARNING:

- Before servicing, turn ignition switch OFF, disconnect battery negative terminal, and wait at least 3 minutes or more. (To discharge backup capacitor.)
- Never use unspecified tester or other measuring device.

1. CHECK HARNESS CONNECTOR

Check the harness connector.

Is the inspection result normal?

- YES >> GO TO 2.
NO >> Replace harness connector.

2. CHECK WIRING HARNESS

Check the wiring harness externals.

Is the inspection result normal?

- YES >> GO TO 3.
NO >> Replace wiring harness.

3. REPLACE REAR SATELLITE SENSOR

- Replace rear satellite sensor RH. Refer to [SR-26, "Removal and Installation"](#).
- Perform DTC confirmation procedure. Refer to [SRC-181, "DTC Logic"](#).

Is DTC detected?

- YES >> GO TO 4.
NO >> INSPECTION END

4. REPLACE AIR BAG DIAGNOSIS SENSOR UNIT

- Replace air bag diagnosis sensor unit. Refer to [SR-29, "Removal and Installation"](#).
- Perform DTC confirmation procedure. Refer to [SRC-181, "DTC Logic"](#).

Is DTC detected?

B1306, B1308, B1309, B1310 SATELLITE SEN RH

< DTC/CIRCUIT DIAGNOSIS >

YES >> GO TO 1.

NO >> INSPECTION END

B1307 SATELLITE SEN RH

< DTC/CIRCUIT DIAGNOSIS >

B1307 SATELLITE SEN RH

DTC Logic

INFOID:000000009650023

DTC DETECTION LOGIC

DTC	Display contents of CONSULT	DTC detecting condition	Possible cause
B1307	SATELLITE SENS RH [UNMATCH]	Rear satellite sensor RH is out of the specified specification	Diagnosis sensor unit or rear satellite sensor RH is different from the part specified

DTC CONFIRMATION PROCEDURE

1. CHECK SELF-DIAG RESULT

With CONSULT

1. Turn ignition switch ON.
2. Perform "Self Diagnostic Result" mode of "AIR BAG" using CONSULT.

Without CONSULT

1. Turn ignition switch ON.
2. Check the air bag warning lamp status. Refer to [SRC-15, "On Board Diagnosis Function"](#).

NOTE:

SRS does not enter the diagnosis mode if no malfunction is detected in the user mode.

Is malfunctioning part detected?

- YES >> Refer to [SRC-183, "Diagnosis Procedure"](#).
NO >> INSPECTION END

Diagnosis Procedure

INFOID:000000009650024

WARNING:

- Before servicing, turn ignition switch OFF, disconnect battery negative terminal, and wait at least 3 minutes or more. (To discharge backup capacitor.)
- Never use unspecified tester or other measuring device.

1. REPLACE REAR SATELLITE SENSOR

1. Replace rear satellite sensor RH. Refer to [SR-26, "Removal and Installation"](#).
2. Perform DTC confirmation procedure. Refer to [SRC-183, "DTC Logic"](#).

Is DTC detected?

- YES >> GO TO 2.
NO >> INSPECTION END

2. REPLACE AIR BAG DIAGNOSIS SENSOR UNIT

1. Replace air bag diagnosis sensor unit. Refer to [SR-29, "Removal and Installation"](#).
2. Perform DTC confirmation procedure. Refer to [SRC-183, "DTC Logic"](#).

Is DTC detected?

- YES >> GO TO 1.
NO >> INSPECTION END

B1311 SATELLITE SEN LH

< DTC/CIRCUIT DIAGNOSIS >

B1311 SATELLITE SEN LH

DTC Logic

INFOID:000000009650025

DTC DETECTION LOGIC

DTC	Display contents of CONSULT	DTC detecting condition	Possible cause
B1311	SATELLITE SENS LH [UNIT FAIL]	Rear satellite sensor LH is malfunctioning	<ul style="list-style-type: none">• Disconnection of wiring harness• Malfunction in rear satellite sensor LH• Malfunction in air bag diagnosis sensor unit

DTC CONFIRMATION PROCEDURE

1. CHECK SELF-DIAG RESULT

With CONSULT

1. Turn ignition switch ON.
2. Perform "Self Diagnostic Result" mode of "AIR BAG" using CONSULT.

Without CONSULT

1. Turn ignition switch ON.
2. Check the air bag warning lamp status. Refer to [SRC-15, "On Board Diagnosis Function"](#).

NOTE:

SRS does not enter the diagnosis mode if no malfunction is detected in the user mode.

Is malfunctioning part detected?

- YES >> Refer to [SRC-184, "Diagnosis Procedure"](#).
NO >> INSPECTION END

Diagnosis Procedure

INFOID:000000009650026

WARNING:

- Before servicing, turn ignition switch OFF, disconnect battery negative terminal, and wait at least 3 minutes or more. (To discharge backup capacitor.)
- Never use unspecified tester or other measuring device.

1. CHECK HARNESS CONNECTOR

Check the harness connector.

Is the inspection result normal?

- YES >> GO TO 2.
NO >> Replace harness connector.

2. CHECK WIRING HARNESS

Check the wiring harness externals.

Is the inspection result normal?

- YES >> GO TO 3.
NO >> Replace wiring harness.

3. REPLACE REAR SATELLITE SENSOR

1. Replace rear satellite sensor LH. Refer to [SR-26, "Removal and Installation"](#).
2. Perform DTC confirmation procedure. Refer to [SRC-184, "DTC Logic"](#).

Is DTC detected?

- YES >> GO TO 4.
NO >> INSPECTION END

4. REPLACE AIR BAG DIAGNOSIS SENSOR UNIT

1. Replace air bag diagnosis sensor unit. Refer to [SR-29, "Removal and Installation"](#).
2. Perform DTC confirmation procedure. Refer to [SRC-184, "DTC Logic"](#).

Is DTC detected?

- YES >> GO TO 1.

B1311 SATELLITE SEN LH

< DTC/CIRCUIT DIAGNOSIS >

NO >> INSPECTION END

A

B

C

D

E

F

G

SRC

I

J

K

L

M

N

O

P

B1313, B1315, B1316, B1317 SATELLITE SEN LH

< DTC/CIRCUIT DIAGNOSIS >

B1313, B1315, B1316, B1317 SATELLITE SEN LH

DTC Logic

INFOID:000000009650027

DTC DETECTION LOGIC

DTC	Display contents of CONSULT	DTC detecting condition	Possible cause
B1313 B1315 B1316 B1317	SATELLITE SENS LH [COMM FAIL]	Rear satellite sensor LH is malfunctioning or out of the specified specification	<ul style="list-style-type: none">• Disconnection of wiring harness• Malfunction in rear satellite sensor LH• Malfunction in air bag diagnosis sensor unit

DTC CONFIRMATION PROCEDURE

1.CHECK SELF-DIAG RESULT

With CONSULT

1. Turn ignition switch ON.
2. Perform "Self Diagnostic Result" mode of "AIR BAG" using CONSULT.

Without CONSULT

1. Turn ignition switch ON.
2. Check the air bag warning lamp status. Refer to [SRC-15, "On Board Diagnosis Function"](#).

NOTE:

SRS does not enter the diagnosis mode if no malfunction is detected in the user mode.

Is malfunctioning part detected?

YES >> Refer to [SRC-186, "Diagnosis Procedure"](#).

NO >> INSPECTION END

Diagnosis Procedure

INFOID:000000009650028

WARNING:

- Before servicing, turn ignition switch OFF, disconnect battery negative terminal, and wait at least 3 minutes or more. (To discharge backup capacitor.)
- Never use unspecified tester or other measuring device.

1.CHECK HARNESS CONNECTOR

Check the harness connector.

Is the inspection result normal?

YES >> GO TO 2.

NO >> Replace harness connector.

2.CHECK WIRING HARNESS

Check the wiring harness externals.

Is the inspection result normal?

YES >> GO TO 3.

NO >> Replace wiring harness.

3.REPLACE REAR SATELLITE SENSOR

1. Replace rear satellite sensor LH. Refer to [SR-26, "Removal and Installation"](#).

2. Perform DTC confirmation procedure. Refer to [SRC-186, "DTC Logic"](#).

Is DTC detected?

YES >> GO TO 4.

NO >> INSPECTION END

4.REPLACE AIR BAG DIAGNOSIS SENSOR UNIT

1. Replace air bag diagnosis sensor unit. Refer to [SR-29, "Removal and Installation"](#).

2. Perform DTC confirmation procedure. Refer to [SRC-186, "DTC Logic"](#).

Is DTC detected?

B1313, B1315, B1316, B1317 SATELLITE SEN LH

< DTC/CIRCUIT DIAGNOSIS >

YES >> GO TO 1.

NO >> INSPECTION END

A

B

C

D

E

F

G

SRC

I

J

K

L

M

N

O

P

B1314 SATELLITE SEN LH

< DTC/CIRCUIT DIAGNOSIS >

B1314 SATELLITE SEN LH

DTC Logic

INFOID:000000009650029

DTC DETECTION LOGIC

DTC	Display contents of CONSULT	DTC detecting condition	Possible cause
B1314	SATELLITE SENS LH [UNMATCH]	Rear satellite sensor LH is out of the specified specification	Diagnosis sensor unit or rear satellite sensor LH is different from the part specified

DTC CONFIRMATION PROCEDURE

1. CHECK SELF-DIAG RESULT

With CONSULT

1. Turn ignition switch ON.
2. Perform "Self Diagnostic Result" mode of "AIR BAG" using CONSULT.

Without CONSULT

1. Turn ignition switch ON.
2. Check the air bag warning lamp status. Refer to [SRC-15. "On Board Diagnosis Function"](#).

NOTE:

SRS does not enter the diagnosis mode if no malfunction is detected in the user mode.

Is malfunctioning part detected?

- YES >> Refer to [SRC-188. "Diagnosis Procedure"](#).
NO >> INSPECTION END

Diagnosis Procedure

INFOID:000000009650030

WARNING:

- Before servicing, turn ignition switch OFF, disconnect battery negative terminal, and wait at least 3 minutes or more. (To discharge backup capacitor.)
- Never use unspecified tester or other measuring device.

1. REPLACE REAR SATELLITE SENSOR

1. Replace rear satellite sensor LH. Refer to [SR-26. "Removal and Installation"](#).
2. Perform DTC confirmation procedure. Refer to [SRC-188. "DTC Logic"](#).

Is DTC detected?

- YES >> GO TO 2.
NO >> INSPECTION END

2. REPLACE AIR BAG DIAGNOSIS SENSOR UNIT

1. Replace air bag diagnosis sensor unit. Refer to [SR-29. "Removal and Installation"](#).
2. Perform DTC confirmation procedure. Refer to [SRC-188. "DTC Logic"](#).

Is DTC detected?

- YES >> GO TO 1.
NO >> INSPECTION END

B1336, B1337 SATELLITE SENSOR RH

< DTC/CIRCUIT DIAGNOSIS >

B1336, B1337 SATELLITE SENSOR RH

DTC Logic

INFOID:000000009650031

DTC DETECTION LOGIC

DTC	Display contents of CONSULT	DTC detecting condition	Possible cause
B1336 B1337	FR-RH DOOR SATEL SENS [SENSOR MALFUNCTION]	Front door satellite sensor RH is malfunctioning	<ul style="list-style-type: none">• Harness or connectors• Malfunction in front door satellite sensor RH• Malfunction in air bag diagnosis sensor unit

DTC CONFIRMATION PROCEDURE

1. CHECK SELF-DIAG RESULT

With CONSULT

1. Turn ignition switch ON.
2. Perform "Self Diagnostic Result" mode of "AIR BAG" using CONSULT.

Without CONSULT

1. Turn ignition switch ON.
2. Check the air bag warning lamp status. Refer to [SRC-15, "On Board Diagnosis Function"](#).

NOTE:

SRS does not enter the diagnosis mode if no malfunction is detected in the user mode.

Is malfunctioning part detected?

- YES >> Refer to [SRC-189, "Diagnosis Procedure"](#).
NO >> INSPECTION END

Diagnosis Procedure

INFOID:000000009650032

WARNING:

- Before servicing, turn ignition switch OFF, disconnect battery negative terminal, and wait at least 3 minutes or more. (To discharge backup capacitor.)
- Never use unspecified tester or other measuring device.

1. CHECK HARNESS CONNECTOR

Check the harness connector.

Is the inspection result normal?

- YES >> GO TO 2.
NO >> Replace harness connector.

2. CHECK WIRING HARNESS

Check the wiring harness externals.

Is the inspection result normal?

- YES >> GO TO 3.
NO >> Replace wiring harness.

3. REPLACE FRONT DOOR SATELLITE SENSOR

1. Replace front door satellite sensor RH. Refer to [SR-26, "Removal and Installation"](#).
2. Perform DTC confirmation procedure. Refer to [SRC-189, "DTC Logic"](#).

Is DTC detected?

- YES >> GO TO 4.
NO >> INSPECTION END

4. REPLACE AIR BAG DIAGNOSIS SENSOR UNIT

1. Replace air bag diagnosis sensor unit. Refer to [SR-29, "Removal and Installation"](#).
2. Perform DTC confirmation procedure. Refer to [SRC-189, "DTC Logic"](#).

Is DTC detected?

B1336, B1337 SATELLITE SENSOR RH

< DTC/CIRCUIT DIAGNOSIS >

YES >> GO TO 1.

NO >> INSPECTION END

B1338, B1340, B1341, B1342 SATELLITE SENSOR RH

< DTC/CIRCUIT DIAGNOSIS >

B1338, B1340, B1341, B1342 SATELLITE SENSOR RH

DTC Logic

INFOID:000000009650033

DTC DETECTION LOGIC

DTC	Display contents of CONSULT	DTC detecting condition	Possible cause
B1338 B1340 B1341 B1342	FR-RH DOOR SATEL SENS [COMM MALFUNC- TION]	Front door satellite sensor RH is malfunctioning	<ul style="list-style-type: none">• Harness or connectors• Malfunction in front door satellite sensor RH• Malfunction in air bag diagnosis sensor unit

DTC CONFIRMATION PROCEDURE

1. CHECK SELF-DIAG RESULT

With CONSULT

1. Turn ignition switch ON.
2. Perform "Self Diagnostic Result" mode of "AIR BAG" using CONSULT.

Without CONSULT

1. Turn ignition switch ON.
2. Check the air bag warning lamp status. Refer to [SRC-15, "On Board Diagnosis Function"](#).

NOTE:

SRS does not enter the diagnosis mode if no malfunction is detected in the user mode.

Is malfunctioning part detected?

- YES >> Refer to [SRC-191, "Diagnosis Procedure"](#).
NO >> INSPECTION END

Diagnosis Procedure

INFOID:000000009650034

WARNING:

- Before servicing, turn ignition switch OFF, disconnect battery negative terminal, and wait at least 3 minutes or more. (To discharge backup capacitor.)
- Never use unspecified tester or other measuring device.

1. CHECK HARNESS CONNECTOR

Check the harness connector.

Is the inspection result normal?

- YES >> GO TO 2.
NO >> Replace harness connector.

2. CHECK WIRING HARNESS

Check the wiring harness externals.

Is the inspection result normal?

- YES >> GO TO 3.
NO >> Replace wiring harness.

3. REPLACE FRONT DOOR SATELLITE SENSOR

1. Replace front door satellite sensor RH. Refer to [SR-26, "Removal and Installation"](#).
2. Perform DTC confirmation procedure. Refer to [SRC-191, "DTC Logic"](#).

Is DTC detected?

- YES >> GO TO 4.
NO >> INSPECTION END

4. REPLACE AIR BAG DIAGNOSIS SENSOR UNIT

1. Replace air bag diagnosis sensor unit. Refer to [SR-29, "Removal and Installation"](#).
2. Perform DTC confirmation procedure. Refer to [SRC-191, "DTC Logic"](#).

Is DTC detected?

B1338, B1340, B1341, B1342 SATELLITE SENSOR RH

< DTC/CIRCUIT DIAGNOSIS >

YES >> GO TO 1.

NO >> INSPECTION END

B1339 SATELLITE SENSOR RH

< DTC/CIRCUIT DIAGNOSIS >

B1339 SATELLITE SENSOR RH

DTC Logic

INFOID:000000009650035

DTC DETECTION LOGIC

DTC	Display contents of CONSULT	DTC detecting condition	Possible cause
B1339	FR-RH DOOR SATEL SENS [MIS-INSTALLATION]	Front door satellite sensor RH is out of the specified specification	Diagnosis sensor unit or front door satellite sensor RH is different from the part specified

DTC CONFIRMATION PROCEDURE

1. CHECK SELF-DIAG RESULT

With CONSULT

1. Turn ignition switch ON.
2. Perform "Self Diagnostic Result" mode of "AIR BAG" using CONSULT.

Without CONSULT

1. Turn ignition switch ON.
2. Check the air bag warning lamp status. Refer to [SRC-15, "On Board Diagnosis Function"](#).

NOTE:

SRS does not enter the diagnosis mode if no malfunction is detected in the user mode.

Is malfunctioning part detected?

- YES >> Refer to [SRC-193, "Diagnosis Procedure"](#).
NO >> INSPECTION END

Diagnosis Procedure

INFOID:000000009650036

WARNING:

- Before servicing, turn ignition switch OFF, disconnect battery negative terminal, and wait at least 3 minutes or more. (To discharge backup capacitor.)
- Never use unspecified tester or other measuring device.

1. REPLACE FRONT DOOR SATELLITE SENSOR

1. Replace front door satellite sensor RH. Refer to [SR-26, "Removal and Installation"](#).
2. Perform DTC confirmation procedure. Refer to [SRC-193, "DTC Logic"](#).

Is DTC detected?

- YES >> GO TO 2.
NO >> INSPECTION END

2. REPLACE AIR BAG DIAGNOSIS SENSOR UNIT

1. Replace air bag diagnosis sensor unit. Refer to [SR-29, "Removal and Installation"](#).
2. Perform DTC confirmation procedure. Refer to [SRC-193, "DTC Logic"](#).

Is DTC detected?

- YES >> GO TO 1.
NO >> INSPECTION END

B1343, B1344 SATELLITE SENSOR LH

< DTC/CIRCUIT DIAGNOSIS >

B1343, B1344 SATELLITE SENSOR LH

DTC Logic

INFOID:000000009650037

DTC DETECTION LOGIC

DTC	Display contents of CONSULT	DTC detecting condition	Possible cause
B1343 B1344	FR-LH DOOR SATEL SENS [SENSOR MALFUNCTION]	Front door satellite sensor LH is malfunctioning	<ul style="list-style-type: none">• Harness or connectors• Malfunction in front door satellite sensor LH• Malfunction in air bag diagnosis sensor unit

DTC CONFIRMATION PROCEDURE

1. CHECK SELF-DIAG RESULT

With CONSULT

1. Turn ignition switch ON.
2. Perform "Self Diagnostic Result" mode of "AIR BAG" using CONSULT.

Without CONSULT

1. Turn ignition switch ON.
2. Check the air bag warning lamp status. Refer to [SRC-15, "On Board Diagnosis Function"](#).

NOTE:

SRS does not enter the diagnosis mode if no malfunction is detected in the user mode.

Is malfunctioning part detected?

- YES >> Refer to [SRC-194, "Diagnosis Procedure"](#).
NO >> INSPECTION END

Diagnosis Procedure

INFOID:000000009650038

WARNING:

- Before servicing, turn ignition switch OFF, disconnect battery negative terminal, and wait at least 3 minutes or more. (To discharge backup capacitor.)
- Never use unspecified tester or other measuring device.

1. CHECK HARNESS CONNECTOR

Check the harness connector.

Is the inspection result normal?

- YES >> GO TO 2.
NO >> Replace harness connector.

2. CHECK WIRING HARNESS

Check the wiring harness externals.

Is the inspection result normal?

- YES >> GO TO 3.
NO >> Replace wiring harness.

3. REPLACE FRONT DOOR SATELLITE SENSOR

1. Replace front door satellite sensor LH. Refer to [SR-26, "Removal and Installation"](#).
2. Perform DTC confirmation procedure. Refer to [SRC-194, "DTC Logic"](#).

Is DTC detected?

- YES >> GO TO 4.
NO >> INSPECTION END

4. REPLACE AIR BAG DIAGNOSIS SENSOR UNIT

1. Replace air bag diagnosis sensor unit. Refer to [SR-29, "Removal and Installation"](#).
2. Perform DTC confirmation procedure. Refer to [SRC-194, "DTC Logic"](#).

Is DTC detected?

B1343, B1344 SATELLITE SENSOR LH

< DTC/CIRCUIT DIAGNOSIS >

YES >> GO TO 1.

NO >> INSPECTION END

A

B

C

D

E

F

G

SRC

I

J

K

L

M

N

O

P

B1345, B1347, B1348, B1349 SATELLITE SENSOR LH

< DTC/CIRCUIT DIAGNOSIS >

B1345, B1347, B1348, B1349 SATELLITE SENSOR LH

DTC Logic

INFOID:000000009650039

DTC DETECTION LOGIC

DTC	Display contents of CONSULT	DTC detecting condition	Possible cause
B1345 B1347 B1348 B1349	FR-LH DOOR SATEL SENS [COMM MALFUNCTION]	Front door satellite sensor LH is malfunctioning	<ul style="list-style-type: none">• Harness or connectors• Malfunction in front door satellite sensor LH• Malfunction in air bag diagnosis sensor unit

DTC CONFIRMATION PROCEDURE

1. CHECK SELF-DIAG RESULT

With CONSULT

1. Turn ignition switch ON.
2. Perform "Self Diagnostic Result" mode of "AIR BAG" using CONSULT.

Without CONSULT

1. Turn ignition switch ON.
2. Check the air bag warning lamp status. Refer to [SRC-15, "On Board Diagnosis Function"](#).

NOTE:

SRS does not enter the diagnosis mode if no malfunction is detected in the user mode.

Is malfunctioning part detected?

YES >> Refer to [SRC-199, "Diagnosis Procedure"](#).

NO >> INSPECTION END

Diagnosis Procedure

INFOID:000000009650040

WARNING:

- Before servicing, turn ignition switch OFF, disconnect battery negative terminal, and wait at least 3 minutes or more. (To discharge backup capacitor.)
- Never use unspecified tester or other measuring device.

1. CHECK HARNESS CONNECTOR

Check the harness connector.

Is the inspection result normal?

YES >> GO TO 2.

NO >> Replace harness connector.

2. CHECK WIRING HARNESS

Check the wiring harness externals.

Is the inspection result normal?

YES >> GO TO 3.

NO >> Replace wiring harness.

3. REPLACE SATELLITE SENSOR

1. Replace front door satellite sensor LH. Refer to [SR-26, "Removal and Installation"](#).

2. Perform DTC confirmation procedure. Refer to [SRC-199, "DTC Logic"](#).

Is DTC detected?

YES >> GO TO 4.

NO >> INSPECTION END

4. REPLACE AIR BAG DIAGNOSIS SENSOR UNIT

1. Replace air bag diagnosis sensor unit. Refer to [SR-29, "Removal and Installation"](#).

2. Perform DTC confirmation procedure. Refer to [SRC-199, "DTC Logic"](#).

Is DTC detected?

B1345, B1347, B1348, B1349 SATELLITE SENSOR LH

< DTC/CIRCUIT DIAGNOSIS >

YES >> GO TO 1.

NO >> INSPECTION END

A

B

C

D

E

F

G

SRC

I

J

K

L

M

N

O

P

B1346 SATELLITE SENSOR LH

< DTC/CIRCUIT DIAGNOSIS >

B1346 SATELLITE SENSOR LH

DTC Logic

INFOID:000000009650041

DTC DETECTION LOGIC

DTC	Display contents of CONSULT	DTC detecting condition	Possible cause
B1346	FR-LH DOOR SATEL SENS [MIS-INSTALLATION]	Front door satellite sensor LH is out of the specified specification	Diagnosis sensor unit or front door satellite sensor LH is different from the part specified

DTC CONFIRMATION PROCEDURE

1. CHECK SELF-DIAG RESULT

Ⓟ With CONSULT

1. Turn ignition switch ON.
2. Perform "Self Diagnostic Result" mode of "AIR BAG" using CONSULT.

ⓧ Without CONSULT

1. Turn ignition switch ON.
2. Check the air bag warning lamp status. Refer to [SRC-15, "On Board Diagnosis Function"](#).

NOTE:

SRS does not enter the diagnosis mode if no malfunction is detected in the user mode.

Is malfunctioning part detected?

- YES >> Refer to [SRC-198, "Diagnosis Procedure"](#).
NO >> INSPECTION END

Diagnosis Procedure

INFOID:000000009650042

WARNING:

- Before servicing, turn ignition switch OFF, disconnect battery negative terminal, and wait at least 3 minutes or more. (To discharge backup capacitor.)
- Never use unspecified tester or other measuring device.

1. REPLACE FRONT DOOR SATELLITE SENSOR

1. Replace front door satellite sensor LH. Refer to [SR-26, "Removal and Installation"](#).
2. Perform DTC confirmation procedure. Refer to [SRC-198, "DTC Logic"](#).

Is DTC detected?

- YES >> GO TO 2.
NO >> INSPECTION END

2. REPLACE AIR BAG DIAGNOSIS SENSOR UNIT

1. Replace air bag diagnosis sensor unit. Refer to [SR-29, "Removal and Installation"](#).
2. Perform DTC confirmation procedure. Refer to [SRC-198, "DTC Logic"](#).

Is DTC detected?

- YES >> GO TO 1.
NO >> INSPECTION END

B1350, B1351 SATELLITE SENSOR

< DTC/CIRCUIT DIAGNOSIS >

B1350, B1351 SATELLITE SENSOR

DTC Logic

INFOID:000000009650043

DTC DETECTION LOGIC

DTC	Display contents of CONSULT	DTC detecting condition	Possible cause
B1350 B1351	FR DOOR SATEL SENS	Front door satellite sensor is malfunctioning or out of the specified specification	<ul style="list-style-type: none">Malfunction in front door satellite sensor LH/RHMalfunction in air bag diagnosis sensor unit

DTC CONFIRMATION PROCEDURE

1. CHECK SELF-DIAG RESULT

With CONSULT

- Turn ignition switch ON.
- Perform "Self Diagnostic Result" mode of "AIR BAG" using CONSULT.

Without CONSULT

- Turn ignition switch ON.
- Check the air bag warning lamp status. Refer to [SRC-15, "On Board Diagnosis Function"](#).

NOTE:

SRS does not enter the diagnosis mode if no malfunction is detected in the user mode.

Is malfunctioning part detected?

- YES >> Refer to [SRC-199, "Diagnosis Procedure"](#).
NO >> INSPECTION END

Diagnosis Procedure

INFOID:000000009650044

WARNING:

- Before servicing, turn ignition switch OFF, disconnect battery negative terminal, and wait at least 3 minutes or more. (To discharge backup capacitor.)
- Never use unspecified tester or other measuring device.

1. REPLACE BOTH OF FRONT DOOR SATELLITE SENSORS

- Replace both of front door satellite sensors. Refer to [SR-26, "Removal and Installation"](#).
- Perform DTC confirmation procedure. Refer to [SRC-199, "DTC Logic"](#).

Is DTC detected?

- YES >> GO TO 2.
NO >> INSPECTION END

2. REPLACE AIR BAG DIAGNOSIS SENSOR UNIT

- Replace air bag diagnosis sensor unit. Refer to [SR-29, "Removal and Installation"](#).
- Perform DTC confirmation procedure. Refer to [SRC-199, "DTC Logic"](#).

Is DTC detected?

- YES >> GO TO 1.
NO >> INSPECTION END

B1378, B1379, B1380, B1381 DIAGNOSIS SENSOR UNIT

< DTC/CIRCUIT DIAGNOSIS >

B1378, B1379, B1380, B1381 DIAGNOSIS SENSOR UNIT

DTC Logic

INFOID:000000009650045

DTC DETECTION LOGIC

DTC	Display contents of CONSULT	DTC detecting condition	Possible cause
B1378 B1379 B1380 B1381	CONTROL UNIT	Air bag diagnosis sensor unit is malfunctioning	Malfunction in air bag diagnosis sensor unit

DTC CONFIRMATION PROCEDURE

1. CHECK SELF-DIAG RESULT

With CONSULT

1. Turn ignition switch ON.
2. Perform "Self Diagnostic Result" mode of "AIR BAG" using CONSULT.

Without CONSULT

1. Turn ignition switch ON.
2. Check the air bag warning lamp status. Refer to [SRC-15, "On Board Diagnosis Function"](#).

NOTE:

SRS does not enter the diagnosis mode if no malfunction is detected in the user mode.

Is malfunctioning part detected?

- YES >> Refer to [SRC-200, "Diagnosis Procedure"](#).
NO >> INSPECTION END

Diagnosis Procedure

INFOID:000000009650046

WARNING:

- Before servicing, turn ignition switch OFF, disconnect battery negative terminal, and wait at least 3 minutes or more. (To discharge backup capacitor.)
- Never use unspecified tester or other measuring device.

1. CHECK HARNESS CONNECTOR

Check the harness connector.

Is the inspection result normal?

- YES >> GO TO 2.
NO >> Replace harness connectors.

2. CHECK WIRING HARNESS

Check the wiring harness externals.

Is the inspection result normal?

- YES >> GO TO 3.
NO >> Replace wiring harness.

3. REPLACE AIR BAG DIAGNOSIS SENSOR UNIT

1. Replace air bag diagnosis sensor unit. Refer to [SR-29, "Removal and Installation"](#).
2. Perform DTC confirmation procedure. Refer to [SRC-200, "DTC Logic"](#).

Is DTC detected?

- YES >> GO TO 1.
NO >> INSPECTION END

SRS AIR BAG WARNING LAMP DOES NOT TURN OFF

< SYMPTOM DIAGNOSIS >

SYMPTOM DIAGNOSIS

SRS AIR BAG WARNING LAMP DOES NOT TURN OFF

Diagnosis Procedure

INFOID:000000009650047

1. CHECK AIR BAG MODULE AND SEAT BELT PRE-TENSIONER

Check the deployment of air bag module and seat belt pre-tensioner.

Is air bag module deployed?

YES >> Replace the malfunctioning parts.

NO >> GO TO 2.

2. CHECK AIR BAG FUSE

Check 10 A fuse [No.2, located in fuse block (J/B)].

Is the inspection result normal?

YES >> GO TO 3.

NO >> Replace the fuse.

3. CHECK HARNESS CONNECTOR

Check the harness connector.

Is the inspection result normal?

YES >> GO TO 4.

NO >> Replace harness connectors.

4. CHECK WIRING HARNESS

Check the wiring harness externals.

Is the inspection result normal?

YES >> GO TO 5.

NO >> Replace wiring harness.

5. REPLACE AIR BAG DIAGNOSIS SENSOR UNIT

1. Replace air bag diagnosis sensor unit. Refer to [SR-29, "Removal and Installation"](#).

2. Check air bag warning lamp operation.

Is the inspection result normal?

YES >> INSPECTION END

NO >> GO TO 6.

6. REPLACE COMBINATION METER

1. Replace combination meter. Refer to [MWI-93, "Removal and Installation"](#).

2. Check air bag warning lamp operation.

Is the inspection result normal?

YES >> INSPECTION END

NO >> GO TO 1.

A
B
C
D
E
F
G
H
I
J
K
L
M
N
O
P

SRC

SRS AIR BAG WARNING LAMP DOES NOT TURN ON

< SYMPTOM DIAGNOSIS >

SRS AIR BAG WARNING LAMP DOES NOT TURN ON

Diagnosis Procedure

INFOID:000000009650048

1.CHECK COMBINATION METER POWER SUPPLY AND GROUND CIRCUIT

Check combination meter unit power supply and ground circuit. Refer to [MWI-72, "COMBINATION METER : Diagnosis Procedure"](#) .

Is the inspection result normal?

YES >> GO TO 2.

NO >> Repair or replace the malfunctioning parts.

2.CHECK HARNESS CONNECTOR

Check the harness connector.

Is the inspection result normal?

YES >> GO TO 3.

NO >> Replace harness connectors.

3.CHECK WIRING HARNESS

Check the wiring harness externals.

Is the inspection result normal?

YES >> GO TO 4.

NO >> Replace wiring harness.

4.CHECK AIR BAG DIAGNOSIS SENSOR UNIT

Disconnect air bag diagnosis sensor unit connector and turn ignition switch ON.

Does air bag warning lamp turn ON?

YES >> Replace air bag diagnosis sensor unit. Refer to [SR-29, "Removal and Installation"](#).

NO >> Replace combination meter. Refer to [MWI-93, "Removal and Installation"](#).

SRS AIR BAG WARNING LAMP BLINKS

< SYMPTOM DIAGNOSIS >

SRS AIR BAG WARNING LAMP BLINKS

Diagnosis Procedure

INFOID:000000009650049

1. PERFORM ZERO POINT RESET

Perform zero point reset. Refer to [SRC-41, "ZERO POINT RESET : Special Repair Requirement"](#).

Is the inspection result normal?

YES >> GO TO 2.

NO >> Repair or replace malfunctioning parts.

2. CHECK BATTERY

Check battery. Refer to [PG-97, "How to Handle Battery"](#).

Is the inspection result normal?

YES >> GO TO 3.

NO >> Repair or replace malfunctioning parts.

3. REPLACE OCCUPANT DETECTION SYSTEM CONTROL UNIT AND SENSOR

1. Replace seat cushion frame.

Refer to [SE-85, "Exploded View"](#) (Manual seat), [SE-99, "Exploded View"](#) (Power seat).

2. Check air bag warning lamp operation.

Is the inspection result normal?

YES >> INSPECTION END

NO >> GO TO 4.

4. REPLACE AIR BAG DIAGNOSIS SENSOR UNIT

1. Replace air bag diagnosis sensor unit. Refer to [SR-29, "Removal and Installation"](#).

2. Check air bag warning lamp operation.

Is the inspection result normal?

YES >> INSPECTION END

NO >> GO TO 1.

A
B
C
D
E
F
G
I
J
K
L
M
N
O
P

SRC