

# SECTION **BCS**

## BODY CONTROL SYSTEM

A  
B  
C

### CONTENTS

|  |    |   |    |   |
|--|----|---|----|---|
| <b>PRECAUTION</b> .....  | 3  | DOOR LOCK : CONSULT Function (BCM - DOOR LOCK) .....                          | 18 | F |
| <b>PRECAUTIONS</b> .....   | 3  | <b>REAR WINDOW DEFOGGER</b> .....   | 19 | G |
| Precaution for Supplemental Restraint System (SRS) "AIR BAG" and "SEAT BELT PRE-TENSIONER" ..... | 3  | REAR WINDOW DEFOGGER : CONSULT Function (BCM - REAR DEFOGGER) .....           | 19 |   |
| Precautions for Removing Battery Terminal .....  | 3  | <b>BUZZER</b> .....   | 19 | H |
| <b>SYSTEM DESCRIPTION</b> .....  | 4  | BUZZER : CONSULT Function (BCM - BUZZER)....                                  | 19 |   |
| <b>COMPONENT PARTS</b> .....   | 4  | <b>INT LAMP</b> .....   | 20 | I |
| <b>BODY CONTROL SYSTEM</b> .....   | 4  | INT LAMP : CONSULT Function (BCM - INT LAMP) .....                            | 20 |   |
| BODY CONTROL SYSTEM : Component Parts Location .....   | 4  | <b>HEADLAMP</b> .....   | 22 | J |
| <b>POWER CONSUMPTION CONTROL SYSTEM</b> .....  | 4  | HEADLAMP : CONSULT Function (BCM - HEADLAMP) (Xenon Type Headlamp) .....      | 22 |   |
| POWER CONSUMPTION CONTROL SYSTEM : Component Parts Location .....                                | 4  | HEADLAMP : CONSULT Function (BCM - HEADLAMP) (Halogen Type Headlamp) .....    | 24 | K |
| <b>SYSTEM</b> .....  | 6  | <b>WIPER</b> .....  | 26 | L |
| <b>BODY CONTROL SYSTEM</b> .....   | 6  | WIPER : CONSULT Function (BCM - WIPER) .....                                  | 26 |   |
| BODY CONTROL SYSTEM : System Description....   | 6  | <b>FLASHER</b> .....  | 27 |   |
| BODY CONTROL SYSTEM : Fail-safe .....  | 7  | FLASHER : CONSULT Function (BCM - FLASHER) (Xenon Type Headlamp) .....        | 27 |   |
| <b>COMBINATION SWITCH READING SYSTEM</b> .....   | 8  | FLASHER : CONSULT Function (BCM - FLASHER) (Halagen Type Headlamp) .....      | 28 |   |
| COMBINATION SWITCH READING SYSTEM : System Description .....                                     | 8  | <b>AIR CONDITIONER</b> .....  | 29 | N |
| <b>SIGNAL BUFFER SYSTEM</b> .....  | 11 | AIR CONDITIONER : CONSULT Function (BCM - AIR CONDITIONER) (Auto A/C) .....   | 29 |   |
| SIGNAL BUFFER SYSTEM : System Description... ..  | 12 | AIR CONDITIONER : CONSULT Function (BCM - AIR CONDITIONER) (Manual A/C) ..... | 29 | O |
| <b>POWER CONSUMPTION CONTROL SYSTEM</b> .....  | 13 | <b>INTELLIGENT KEY</b> .....  | 29 | P |
| POWER CONSUMPTION CONTROL SYSTEM : System Description .....                                      | 13 | INTELLIGENT KEY : CONSULT Function (BCM - INTELLIGENT KEY) .....              | 29 |   |
| <b>DIAGNOSIS SYSTEM (BCM)</b> .....  | 16 | <b>COMB SW</b> .....  | 33 |   |
| <b>COMMON ITEM</b> .....   | 16 | COMB SW : CONSULT Function (BCM - COMB SW) .....                              | 33 |   |
| COMMON ITEM : CONSULT Function (BCM - COMMON ITEM) .....   | 16 | <b>BCM</b> .....  | 34 |   |
| <b>DOOR LOCK</b> .....   | 17 |   |    |   |

**BCS**

|  |           |   |           |
|--|-----------|---|-----------|
| BCM : CONSULT Function (BCM - BCM) .....   | 34        | CONFIGURATION (BCM) : Description .....               | 84        |
| <b>IMMU</b> .....  | <b>34</b> | CONFIGURATION (BCM) : Work Procedure .....            | 84        |
| IMMU : CONSULT Function (BCM - IMMU) .....   | 34        | CONFIGURATION (BCM) : Configuration list .....        | 85        |
| <b>BATTERY SAVER</b> .....   | <b>35</b> | <b>SHIPPING MODE CANCEL OPERATION</b> .....           | <b>86</b> |
| BATTERY SAVER : CONSULT Function (BCM -<br>BATTERY SAVER) .....                              | 35        | Description .....                                     | 86        |
| <b>TRUNK</b> .....   | <b>36</b> | Work Procedure .....                                  | 86        |
| TRUNK : CONSULT Function (BCM - TRUNK) ....  | 36        | <b>DTC/CIRCUIT DIAGNOSIS</b> .....                    | <b>87</b> |
| <b>THEFT ALM</b> .....   | <b>36</b> | <b>U1000 CAN COMM</b> .....                           | <b>87</b> |
| THEFT ALM : CONSULT Function (BCM -<br>THEFT) .....  | 36        | Description .....                                     | 87        |
| <b>RETAIND PWR</b> .....   | <b>37</b> | DTC Logic .....                                       | 87        |
| RETAIND PWR : CONSULT Function (BCM - RE-<br>TAINED PWR) (Front Window Anti-pinch) .....     | 37        | Diagnosis Procedure .....                             | 87        |
| RETAIND PWR : CONSULT Function (BCM - RE-<br>TAINED PWR) (Driver Side Window Anti-pinch) ... | 38        | <b>U1010 CONTROL UNIT (CAN)</b> .....                 | <b>88</b> |
| <b>SIGNAL BUFFER</b> .....   | <b>38</b> | DTC Logic .....                                       | 88        |
| SIGNAL BUFFER : CONSULT Function (BCM -<br>SIGNAL BUFFER) .....                              | 38        | Diagnosis Procedure .....                             | 88        |
| <b>AIR PRESSURE MONITOR</b> .....  | <b>38</b> | <b>U0415 VEHICLE SPEED</b> .....                      | <b>89</b> |
| AIR PRESSURE MONITOR : CONSULT Function<br>(BCM - AIR PRESSURE MONITOR) .....                | 38        | Description .....                                     | 89        |
| <b>ECU DIAGNOSIS INFORMATION</b> .....   | <b>40</b> | DTC Logic .....                                       | 89        |
| <b>BCM</b> .....   | <b>40</b> | Diagnosis Procedure .....                             | 89        |
| Reference Value .....  | 40        | <b>B2562 LOW VOLTAGE</b> .....                        | <b>90</b> |
| Fail-safe .....  | 62        | DTC Logic .....                                       | 90        |
| DTC Inspection Priority Chart .....  | 62        | Diagnosis Procedure .....                             | 90        |
| DTC Index .....  | 63        | <b>POWER SUPPLY AND GROUND CIRCUIT</b> ....           | <b>91</b> |
| <b>WIRING DIAGRAM</b> .....  | <b>66</b> | Diagnosis Procedure .....                             | 91        |
| <b>BCM</b> .....   | <b>66</b> | <b>COMBINATION SWITCH OUTPUT CIRCUIT</b> ...          | <b>92</b> |
| Wiring Diagram .....   | 66        | Diagnosis Procedure .....                             | 92        |
| <b>BASIC INSPECTION</b> .....  | <b>83</b> | <b>COMBINATION SWITCH INPUT CIRCUIT</b> .....         | <b>94</b> |
| <b>INSPECTION AND ADJUSTMENT</b> .....   | <b>83</b> | Diagnosis Procedure .....                             | 94        |
| <b>ADDITIONAL SERVICE WHEN REPLACING<br/>CONTROL UNIT (BCM)</b> .....                        | <b>83</b> | <b>SYMPTOM DIAGNOSIS</b> .....                        | <b>96</b> |
| ADDITIONAL SERVICE WHEN REPLACING<br>CONTROL UNIT (BCM) : Description .....                  | 83        | <b>COMBINATION SWITCH SYSTEM SYMP-<br/>TOMS</b> ..... | <b>96</b> |
| ADDITIONAL SERVICE WHEN REPLACING<br>CONTROL UNIT (BCM) : Work Procedure .....               | 83        | Symptom Table .....                                   | 96        |
| <b>CONFIGURATION (BCM)</b> .....   | <b>83</b> | <b>NORMAL OPERATING CONDITION</b> .....               | <b>97</b> |
|  |           | Description .....                                     | 97        |
|  |           | <b>REMOVAL AND INSTALLATION</b> .....                 | <b>98</b> |
|  |           | <b>BCM</b> .....                                      | <b>98</b> |
|  |           | Removal and Installation .....                        | 98        |
|  |           | <b>COMBINATION SWITCH</b> .....                       | <b>99</b> |
|  |           | Exploded View .....                                   | 99        |
|  |           | Removal and Installation .....                        | 99        |

# PRECAUTIONS

< PRECAUTION >

## PRECAUTION

### PRECAUTIONS

#### Precaution for Supplemental Restraint System (SRS) "AIR BAG" and "SEAT BELT PRE-TENSIONER"

INFOID:000000011324299

The Supplemental Restraint System such as "AIR BAG" and "SEAT BELT PRE-TENSIONER", used along with a front seat belt, helps to reduce the risk or severity of injury to the driver and front passenger for certain types of collision. This system includes seat belt switch inputs and dual stage front air bag modules. The SRS system uses the seat belt switches to determine the front air bag deployment, and may only deploy one front air bag, depending on the severity of a collision and whether the front occupants are belted or unbelted. Information necessary to service the system safely is included in the "SRS AIR BAG" and "SEAT BELT" of this Service Manual.

#### **WARNING:**

Always observe the following items for preventing accidental activation.

- To avoid rendering the SRS inoperative, which could increase the risk of personal injury or death in the event of a collision that would result in air bag inflation, all maintenance must be performed by an authorized NISSAN/INFINITI dealer.
- Improper maintenance, including incorrect removal and installation of the SRS, can lead to personal injury caused by unintentional activation of the system. For removal of Spiral Cable and Air Bag Module, see "SRS AIR BAG".
- Never use electrical test equipment on any circuit related to the SRS unless instructed to in this Service Manual. SRS wiring harnesses can be identified by yellow and/or orange harnesses or harness connectors.

#### PRECAUTIONS WHEN USING POWER TOOLS (AIR OR ELECTRIC) AND HAMMERS

#### **WARNING:**

Always observe the following items for preventing accidental activation.

- When working near the Air Bag Diagnosis Sensor Unit or other Air Bag System sensors with the ignition ON or engine running, never use air or electric power tools or strike near the sensor(s) with a hammer. Heavy vibration could activate the sensor(s) and deploy the air bag(s), possibly causing serious injury.
- When using air or electric power tools or hammers, always switch the ignition OFF, disconnect the battery, and wait at least 3 minutes before performing any service.

#### Precautions for Removing Battery Terminal

INFOID:000000011324300

- When removing the 12V battery terminal, turn OFF the ignition switch and wait at least 30 seconds.

#### **NOTE:**

ECU may be active for several tens of seconds after the ignition switch is turned OFF. If the battery terminal is removed before ECU stops, then a DTC detection error or ECU data corruption may occur.

- For vehicles with the 2-batteries, be sure to connect the main battery and the sub battery before turning ON the ignition switch.

#### **NOTE:**

If the ignition switch is turned ON with any one of the terminals of main battery and sub battery disconnected, then DTC may be detected.

- After installing the 12V battery, always check "Self Diagnosis Result" of all ECUs and erase DTC.

#### **NOTE:**

The removal of 12V battery may cause a DTC detection error.

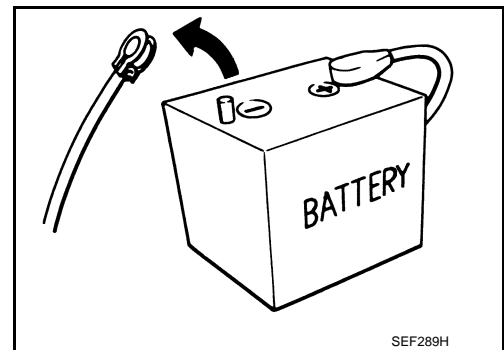

A  
B  
C  
D  
E  
F  
G  
H  
I  
J  
K  
L  
N  
O  
P

BCS

## COMPONENT PARTS

< SYSTEM DESCRIPTION >

### SYSTEM DESCRIPTION

#### COMPONENT PARTS

#### BODY CONTROL SYSTEM

#### BODY CONTROL SYSTEM : Component Parts Location

INFOID:000000011324301

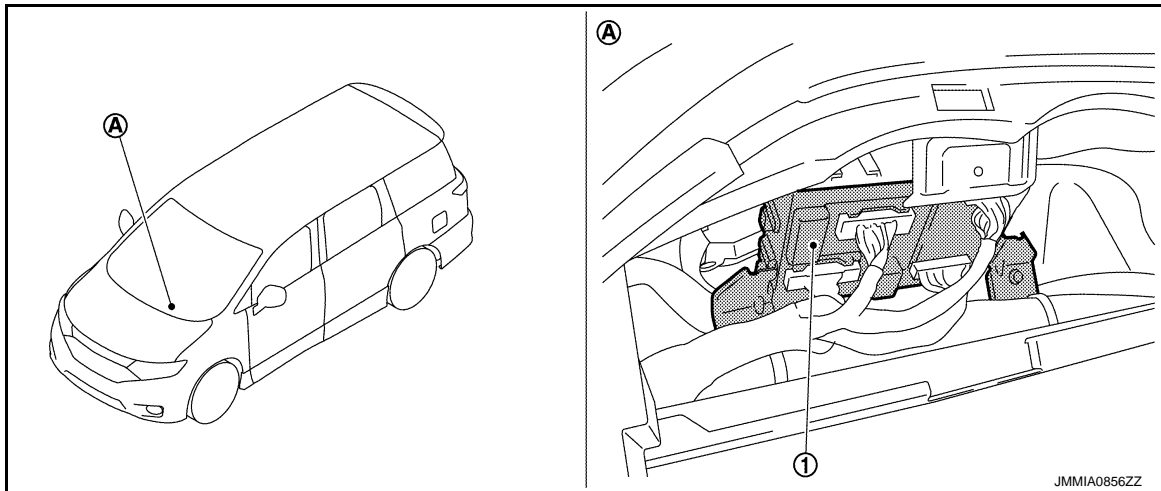

1. BCM
- A. Behind of combination meter

#### POWER CONSUMPTION CONTROL SYSTEM

#### POWER CONSUMPTION CONTROL SYSTEM : Component Parts Location

INFOID:000000011324302

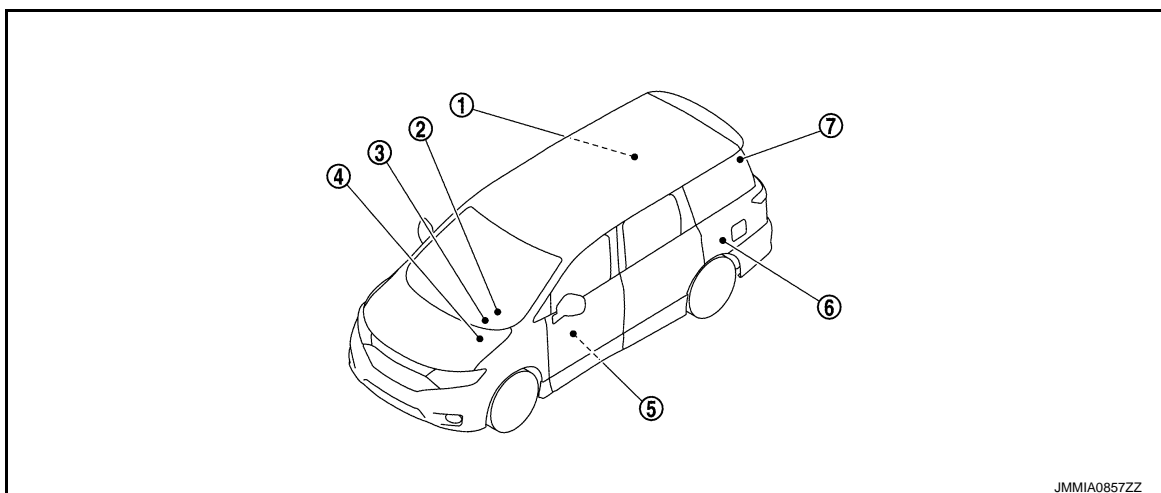

1. Sliding door control unit RH  
Refer to [DLK-23. "AUTOMATIC SLIDING DOOR SYSTEM : Component Parts Location"](#).
2. Combination meter  
Refer to [MWI-6. "METER SYSTEM : Component Parts Location"](#).
3. BCM  
Refer to [BCS-4. "BODY CONTROL SYSTEM : Component Parts Location"](#).

# COMPONENT PARTS

## < SYSTEM DESCRIPTION >

- 
- |   |   |  |     |
|---|---|--|-----|
| 4. IPDM E/R<br>Refer to <a href="#">PCS-4, "IPDM E/R : Component Parts Location"</a> .  | 5. Driver seat control unit<br>Refer to <a href="#">ADP-5, "Component Parts Location"</a> . | 6. Sliding door control unit LH<br>Refer to <a href="#">DLK-23, "AUTOMATIC SLIDING DOOR SYSTEM : Component Parts Location"</a> . | A   |
| 7. Automatic back door control module<br>Refer to <a href="#">DLK-22, "AUTOMATIC BACK DOOR SYSTEM : Component Parts Location"</a> . |   |  | B   |
|   |   |  | C   |
|   |   |  | D   |
|   |   |  | E   |
|   |   |  | F   |
|   |   |  | G   |
|   |   |  | H   |
|   |   |  | I   |
|   |   |  | J   |
|   |   |  | K   |
|   |   |  | L   |
|   |   |  | BCS |
|   |   |  | N   |
|   |   |  | O   |
|   |   |  | P   |

# SYSTEM

< SYSTEM DESCRIPTION >

## SYSTEM

### BODY CONTROL SYSTEM

#### BODY CONTROL SYSTEM : System Description

INFOID:000000011324303

#### OUTLINE

- BCM (Body Control Module) controls the various electrical components. It inputs the information required to the control from CAN communication and the signal received from each switch and sensor.
- BCM has combination switch reading function for reading the operation status of combination switches (light, turn signal, wiper and washer) in addition to a function for controlling the operation of various electrical components. It also has the signal transmission function as the passed point of signal and the power saving control function that reduces the power consumption with the ignition switch OFF.
- BCM is equipped with the diagnosis function that performs the diagnosis with CONSULT and various settings.

#### BCM CONTROL FUNCTION LIST

| System  | Reference   |
|---|---|
| Combination switch reading system                         | <a href="#">BCS-8, "COMBINATION SWITCH READING SYSTEM : System Description"</a>   |
| Signal buffer system                                      | <a href="#">BCS-12, "SIGNAL BUFFER SYSTEM : System Description"</a>   |
| Power consumption control system                          | <a href="#">BCS-13, "POWER CONSUMPTION CONTROL SYSTEM : System Description"</a>   |
| Headlamp system   | <ul style="list-style-type: none"> <li>• <a href="#">EXL-12, "HEADLAMP SYSTEM : System Description"</a> (Xenon type headlamp)</li> <li>• <a href="#">EXL-124, "HEADLAMP SYSTEM : System Description"</a> (Halogen type headlamp)</li> </ul>   |
| Auto light system   | <ul style="list-style-type: none"> <li>• Xenon type headlamp models               <ul style="list-style-type: none"> <li>- <a href="#">EXL-14, "AUTO LIGHT SYSTEM (EXCEPT FOR CANADA) : System Description"</a> (Except for Canada)</li> <li>- <a href="#">EXL-17, "AUTO LIGHT SYSTEM (FOR CANADA) : System Description"</a> (For Canada)</li> </ul> </li> <li>• Halogen type headlamp models               <ul style="list-style-type: none"> <li>- <a href="#">EXL-14, "AUTO LIGHT SYSTEM (EXCEPT FOR CANADA) : System Description"</a> (Except for Canada)</li> <li>- <a href="#">EXL-129, "AUTO LIGHT SYSTEM (FOR CANADA) : System Description"</a> (For Canada)</li> </ul> </li> </ul> |
| Daytime running light system                              | <ul style="list-style-type: none"> <li>• <a href="#">EXL-20, "DAYTIME RUNNING LIGHT SYSTEM : System Description"</a> (Xenon type headlamp)</li> <li>• <a href="#">EXL-132, "DAYTIME RUNNING LIGHT SYSTEM : System Description"</a> (Halogen type headlamp)</li> </ul>   |
| Turn signal and hazard warning lamp system                | <ul style="list-style-type: none"> <li>• <a href="#">EXL-22, "TURN SIGNAL AND HAZARD WARNING LAMP SYSTEM : System Description"</a> (Xenon type headlamp)</li> <li>• <a href="#">EXL-134, "TURN SIGNAL AND HAZARD WARNING LAMP SYSTEM : System Description"</a> (Halogen type headlamp)</li> </ul>   |
| Parking, license plate, side marker and tail lamps system | <ul style="list-style-type: none"> <li>• <a href="#">EXL-23, "PARKING, LICENSE PLATE, SIDE MARKER AND TAIL LAMP SYSTEM : System Description"</a> (Xenon type headlamp)</li> <li>• <a href="#">EXL-135, "PARKING, LICENSE PLATE, SIDE MARKER AND TAIL LAMP SYSTEM : System Description"</a> (Halogen type headlamp)</li> </ul>   |
| Front fog lamp system                                     | <ul style="list-style-type: none"> <li>• <a href="#">EXL-26, "FRONT FOG LAMP SYSTEM : System Description"</a> (Xenon type headlamp)</li> <li>• <a href="#">EXL-138, "FRONT FOG LAMP SYSTEM : System Description"</a> (Halogen type headlamp)</li> </ul>   |
| Exterior lamp battery saver system                        | <ul style="list-style-type: none"> <li>• <a href="#">EXL-28, "EXTERIOR LAMP BATTERY SAVER SYSTEM : System Description"</a> (Xenon type headlamp)</li> <li>• <a href="#">EXL-140, "EXTERIOR LAMP BATTERY SAVER SYSTEM : System Description"</a> (Halogen type headlamp)</li> </ul>   |

# SYSTEM

## < SYSTEM DESCRIPTION >

| System  | Reference   |
|---|---|
| Interior room lamp control system               | <a href="#">INL-6, "INTERIOR ROOM LAMP CONTROL SYSTEM : System Description"</a>   |
| Interior room lamp battery saver system         | <a href="#">INL-11, "INTERIOR ROOM LAMP BATTERY SAVER SYSTEM : System Description"</a>  |
| Front wiper and washer system                   | <a href="#">WW-8, "FRONT WIPER AND WASHER SYSTEM : System Description"</a>  |
| Rear wiper and washer system                    | <a href="#">WW-12, "REAR WIPER AND WASHER SYSTEM : System Description"</a>  |
| Rear window defogger system                     | <a href="#">DEF-7, "System Description"</a>   |
| Warning chime system                            | <a href="#">WCS-5, "WARNING CHIME SYSTEM : System Description"</a>  |
| Air conditioning control system                 | <ul style="list-style-type: none"> <li><a href="#">HAC-16, "FRONT AUTOMATIC AIR CONDITIONING SYSTEM : System Description"</a> (Automatic air conditioning)</li> <li><a href="#">HAC-162, "FRONT MANUAL AIR CONDITIONING SYSTEM : System Description"</a> (Manual air conditioning)</li> </ul> |
| Power door lock system                          | <a href="#">DLK-33, "System Description"</a>  |
| Intelligent Key system/engine start system      | <a href="#">DLK-36, "INTELLIGENT KEY SYSTEM : System Description"</a>   |
| Nissan Vehicle Immobilizer System (NVIS) - NATS | <a href="#">SEC-14, "NISSAN VEHICLE IMMOBILIZER SYSTEM-NATS : System Description"</a>   |
| Vehicle security system                         | Theft warning alarm   |
|   | Panic alarm   |
| Power window system                             | <a href="#">PWC-9, "System Description"</a>   |
| Retained accessory power (RAP) system           | <a href="#">PWC-9, "System Description"</a>   |
| TPMS (Tire Pressure Monitoring System)          | <a href="#">WT-8, "System Description"</a>  |

## BODY CONTROL SYSTEM : Fail-safe

INFOID:000000011324304

### FAIL-SAFE CONTROL BY DTC

BCM performs fail-safe control when any DTC are detected.

| Display contents of CONSULT | Fail-safe               | Cancellation  |
|-----------------------------|-------------------------|---|
| B2192: ID DISCORD BCM-ECM   | Inhibit engine cranking | Erase DTC   |
| B2193: CHAIN OF BCM-ECM     | Inhibit engine cranking | Erase DTC   |
| B2195: ANTI-SCANNING        | Inhibit engine cranking | Ignition switch ON → OFF  |
| B2196: DONGLE NG            | Inhibit engine cranking | Erase DTC   |
| B2198: NATS ANTENNA AMP     | Inhibit engine cranking | Erase DTC   |
| B2608: STARTER RELAY        | Inhibit engine cranking | 500 ms after the following signal communication status becomes consistent <ul style="list-style-type: none"> <li>Starter motor relay control signal</li> <li>Starter relay status signal (CAN)</li> </ul>                               |
| B260F: ENG STATE SIG LOST   | Inhibit engine cranking | When any of the following conditions are fulfilled <ul style="list-style-type: none"> <li>Ignition switch changes to ACC</li> <li>Receives engine status signal (CAN)</li> </ul>  |
| B26F1: IGN RELAY OFF        | Inhibit engine cranking | When the following conditions are fulfilled <ul style="list-style-type: none"> <li>Ignition switch ON signal (CAN: Transmitted from BCM): ON</li> <li>Ignition switch ON signal (CAN: Transmitted from IPDM E/R): ON</li> </ul>         |
| B26F2: IGN RELAY ON         | Inhibit engine cranking | When the following conditions are fulfilled <ul style="list-style-type: none"> <li>Ignition switch ON signal (CAN: Transmitted from BCM): OFF</li> <li>Ignition switch ON signal (CAN: Transmitted from IPDM E/R): OFF</li> </ul>       |
| B26F3: START CONT RLY ON    | Inhibit engine cranking | When the following conditions are fulfilled <ul style="list-style-type: none"> <li>Starter control relay signal (CAN: Transmitted from BCM): OFF</li> <li>Starter control relay signal (CAN: Transmitted from IPDM E/R): OFF</li> </ul> |

# SYSTEM

## < SYSTEM DESCRIPTION >

| Display contents of CONSULT | Fail-safe   | Cancellation  |
|-----------------------------|---|---|
| B26F4: START CONT RLY OFF   | Inhibit engine cranking                           | When the following conditions are fulfilled <ul style="list-style-type: none"> <li>• Starter control relay signal (CAN: Transmitted from BCM): ON</li> <li>• Starter control relay signal (CAN: Transmitted from IPDM E/R): ON</li> </ul> |
| B26F7: BCM                  | Inhibit engine cranking by Intelligent Key system | When room antenna and luggage room antenna functions normally   |

### REAR WIPER MOTOR PROTECTION

BCM detects the rear wiper stopping position according to the rear wiper stop position signal. When the rear wiper stop position signal does not change for more than 5 seconds while driving the rear wiper, BCM stops power supply to protect the rear wiper motor.

Condition of cancellation

1. More than 1 minute is passed after the rear wiper stop.
2. Turn rear wiper switch OFF.
3. Operate the rear wiper switch or rear washer switch.

### FAIL-SAFE CONTROL OF COMBINATION SWITCH READING FUNCTION CAUSED BY LOW POWER SUPPLY VOLTAGE

If voltage of battery power supply lower, BCM maintains combination switch reading to the status when input voltage is less than approximately 9 V.

#### NOTE:

When voltage of battery power supply is approximately 9 V or more, combination switch reading function returns to normal operation.

## COMBINATION SWITCH READING SYSTEM

### COMBINATION SWITCH READING SYSTEM : System Description

INFOID:000000011324305

#### SYSTEM DIAGRAM

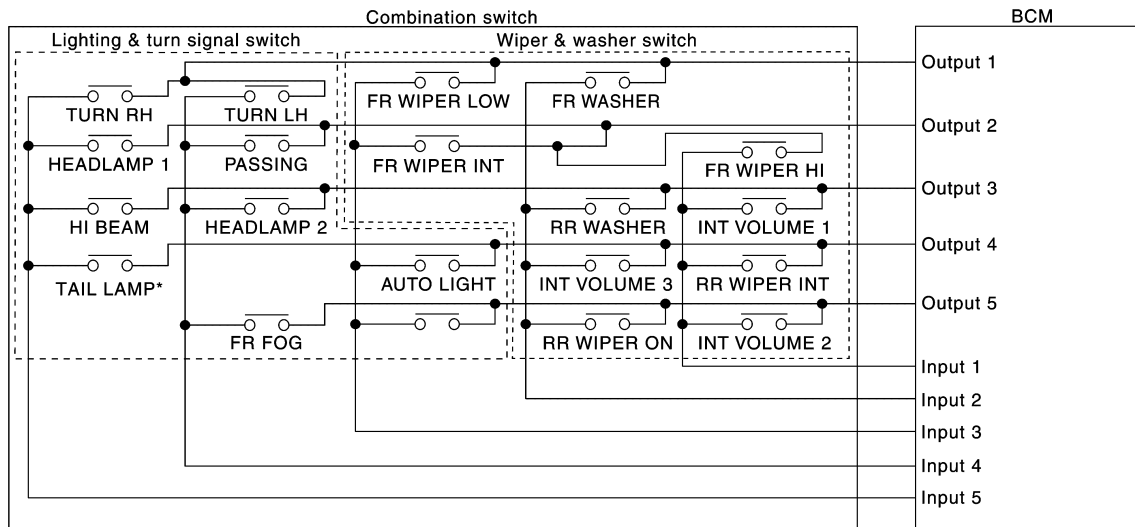

JMMIA0636GB

#### NOTE:

\*: TAIL LAMP switch links lighting switch 1ST and 2ND positions.

#### OUTLINE

- BCM reads the status of the combination switch (light, turn signal, wiper and washer) and recognizes the status of each switch.
- BCM has a combination of 5 output terminals (OUTPUT 1 - 5) and 5 input terminals (INPUT 1 - 5). It reads a maximum of 20 switch status.

#### COMBINATION SWITCH MATRIX



# SYSTEM

## < SYSTEM DESCRIPTION >

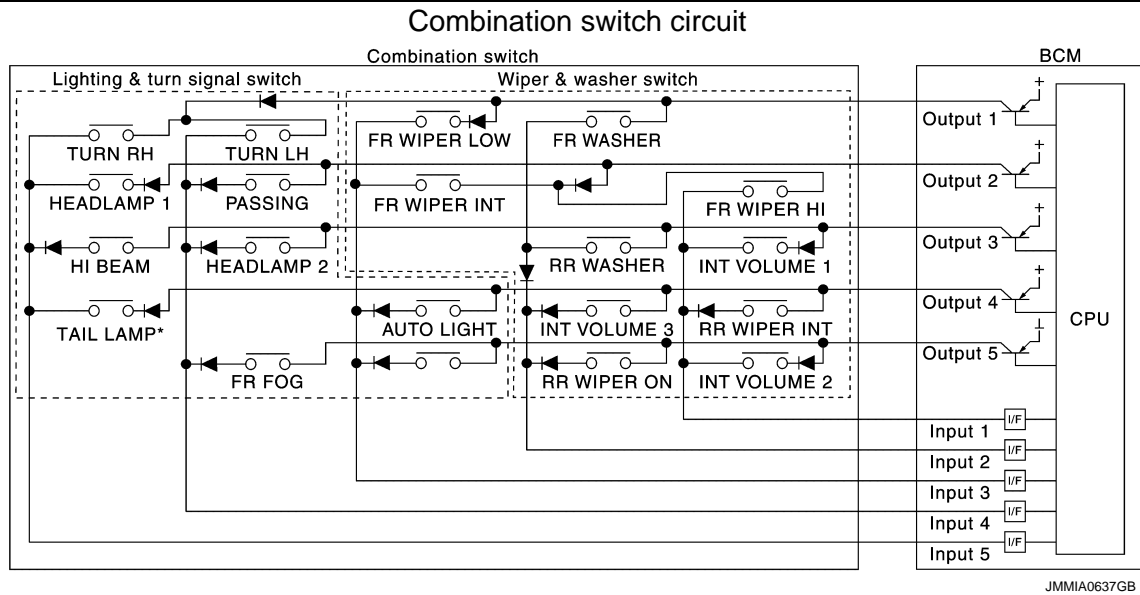

**NOTE:**

\*: TAIL LAMP switch links lighting switch 1ST and 2ND positions.

Combination switch INPUT-OUTPUT system list

| System   | INPUT 1      | INPUT 2      | INPUT 3      | INPUT 4    | INPUT 5    |
|----------|--------------|--------------|--------------|------------|------------|
| OUTPUT 1 | —            | FR WASHER    | FR WIPER LOW | TURN LH    | TURN RH    |
| OUTPUT 2 | FR WIPER HI  | —            | FR WIPER INT | PASSING    | HEADLAMP 1 |
| OUTPUT 3 | INT VOLUME 1 | RR WASHER    | —            | HEADLAMP 2 | HI BEAM    |
| OUTPUT 4 | RR WIPER INT | INT VOLUME 3 | AUTO LIGHT   | —          | TAIL LAMP  |
| OUTPUT 5 | INT VOLUME 2 | RR WIPER ON  | —            | FR FOG     | —          |

**NOTE:**

Headlamp has a dual system switch.

### COMBINATION SWITCH READING FUNCTION

**Description**

- BCM reads the status of the combination switch at 10 ms interval normally.

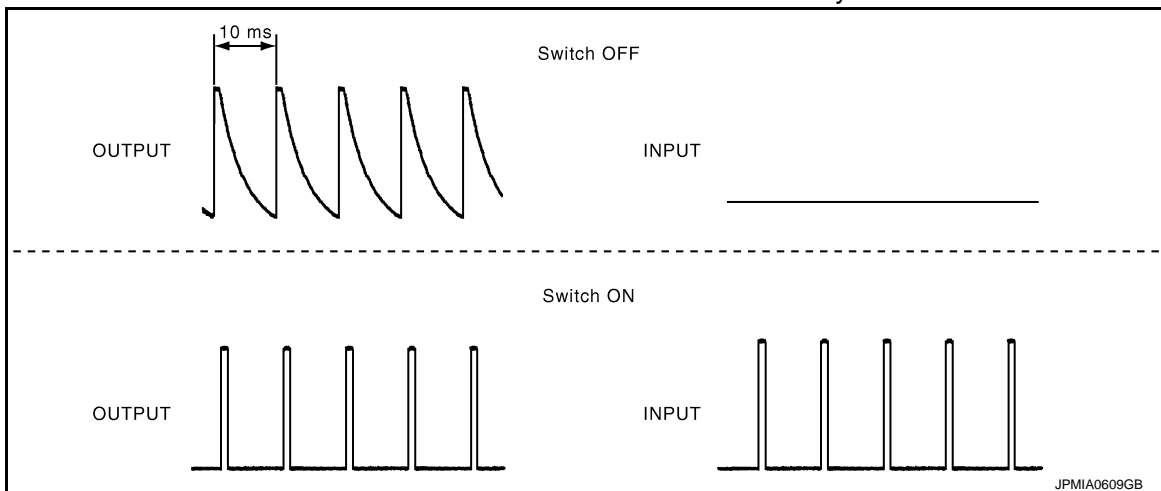

**NOTE:**

BCM reads the status of the combination switch at 60 ms interval when BCM is controlled at low power consumption control mode.

- BCM operates as follows and judges the status of the combination switch.
  - It operates the transistor on OUTPUT side in the following order: OUTPUT 1 → 2 → 3 → 4 → 5, and outputs voltage waveform.

# SYSTEM

## < SYSTEM DESCRIPTION >

- The voltage waveform of OUTPUT corresponding to the formed circuit is input into the interface on INPUT side if any (1 or more) switches are ON.
- It reads this change of the voltage as the status signal of the combination switch.

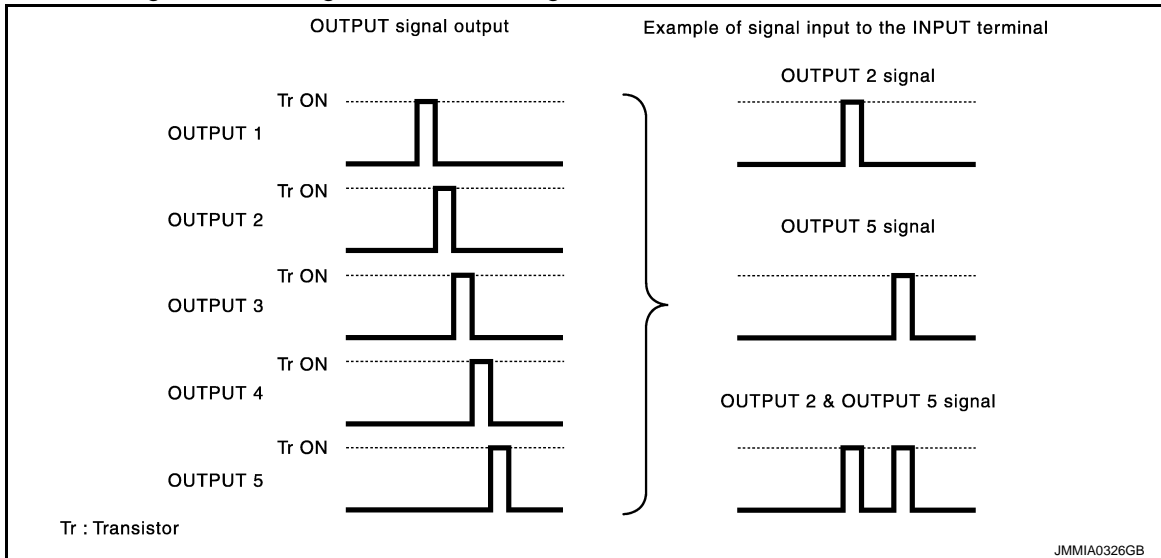

### Operation Example

In the following operation example, the combination of the status signals of the combination switch is replaced as follows: INPUT 1 - 5 to "1 - 5" and OUTPUT 1 - 5 to "A - E".

Example 1: When a switch (TAIL LAMP switch) is turned ON

- The circuit between OUTPUT 4 and INPUT 5 is formed when the TAIL LAMP switch is turned ON.

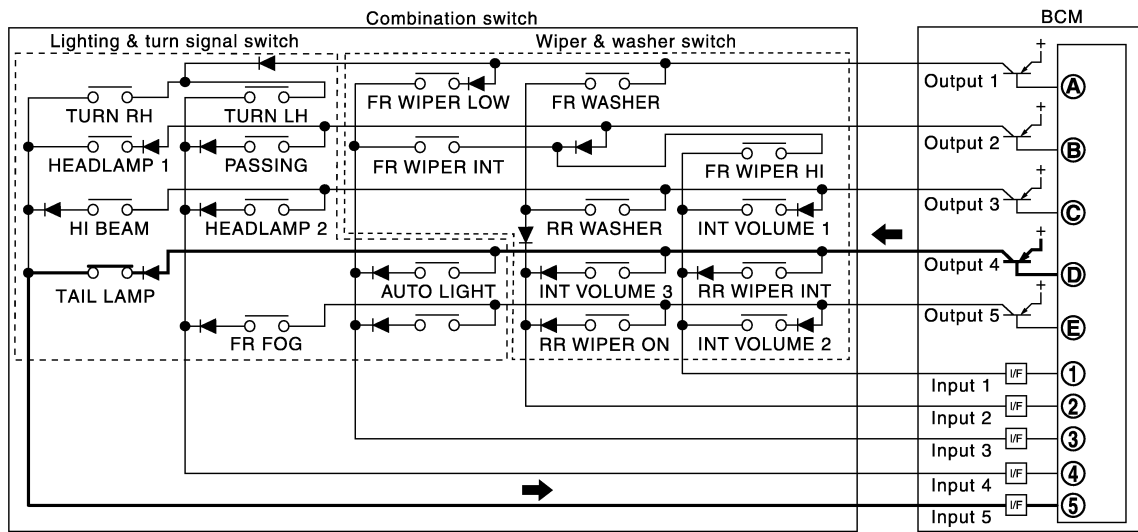

- BCM detects the combination switch status signal "5D" when the signal of OUTPUT 4 is input to INPUT 5.
- BCM judges that the TAIL LAMP switch is ON when the signal "5D" is detected.

Example 2: When some switches (TURN RH switch, TAIL LAMP switch) are turned ON

# SYSTEM

## < SYSTEM DESCRIPTION >

- The circuits between OUTPUT 1 and INPUT 5 and between OUTPUT 4 and INPUT 5 are formed when the TURN RH switch and TAIL LAMP switch are turned ON.

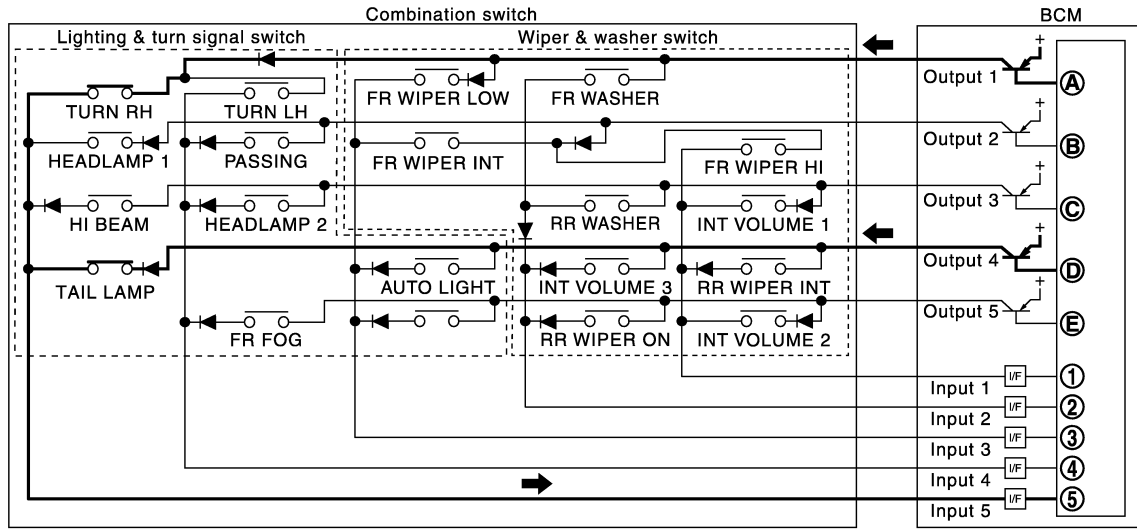

JPMIA1546GB

- BCM detects the combination switch status signal "5AD" when the signals of OUTPUT 1 and OUTPUT 4 are input to INPUT 5.
- BCM judges that the TURN RH switch and TAIL LAMP switch are ON when the signal "5AD" is detected.

### WIPER INTERMITTENT DIAL POSITION

BCM judges the wiper intermittent dial 1 - 7 by the status of INT VOLUME 1, 2 and 3 switches.

| Wiper intermittent dial position | Switch status |              |              |
|----------------------------------|---------------|--------------|--------------|
|                                  | INT VOLUME 1  | INT VOLUME 2 | INT VOLUME 3 |
| 1                                | ON            | ON           | ON           |
| 2                                | ON            | ON           | OFF          |
| 3                                | ON            | OFF          | OFF          |
| 4                                | OFF           | OFF          | OFF          |
| 5                                | OFF           | OFF          | ON           |
| 6                                | OFF           | ON           | ON           |
| 7                                | OFF           | ON           | OFF          |

#### NOTE:

For details of wiper intermittent dial position, refer to [WW-8, "FRONT WIPER AND WASHER SYSTEM : System Description"](#).

### SIGNAL BUFFER SYSTEM

A  
B  
C  
D  
E  
F  
G  
H  
I  
J  
K  
L  
N  
O  
P

BCS

# SYSTEM

< SYSTEM DESCRIPTION >

## SIGNAL BUFFER SYSTEM : System Description

INFOID:000000011324306

### SYSTEM DIAGRAM

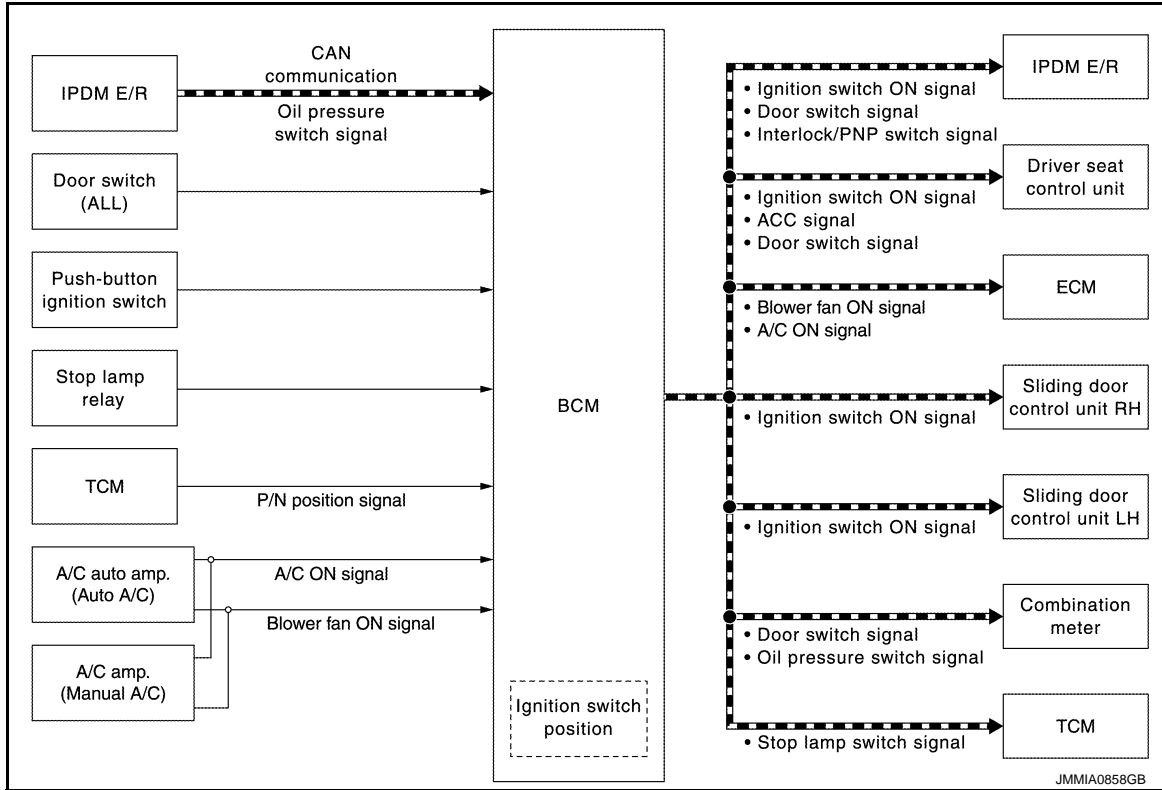

### OUTLINE

BCM has the signal transmission function that outputs/transmits each input/received signal to each unit.

### Signal transmission function list

| Signal name   | Input   | Output   | Description   |
|---|---|--|---|
| <ul style="list-style-type: none"> <li>Ignition switch ON signal</li> <li>ACC signal</li> </ul> | Push-button ignition switch (Push switch)   | <ul style="list-style-type: none"> <li>IPDM E/R (CAN)</li> <li>Driver seat control unit (CAN)</li> <li>Sliding door control unit LH (CAN)</li> <li>Sliding door control unit RH (CAN)</li> </ul> | Inputs the push-button ignition switch (push switch) signal and transmits the ignition switch status judged with BCM via CAN communication. |
| Door switch signal  | Any door switch   | <ul style="list-style-type: none"> <li>Combination meter (CAN)</li> <li>IPDM E/R (CAN)</li> <li>Driver seat control unit (CAN)</li> </ul>  | Inputs the door switch signal and transmits it via CAN communication.   |
| Oil pressure switch signal  | IPDM E/R (CAN)  | Combination meter (CAN)  | Transmits the received oil pressure switch signal via CAN communication.  |
| Blower fan ON signal  | <ul style="list-style-type: none"> <li>A/C auto amp. (Auto A/C)</li> <li>A/C amp. (Manual A/C)</li> </ul> | ECM (CAN)  | Input blower fan ON signal, and transmits it via CAN communication.   |
| A/C ON signal   | <ul style="list-style-type: none"> <li>A/C auto amp. (Auto A/C)</li> <li>A/C amp. (Manual A/C)</li> </ul> | ECM (CAN)  | Input A/C ON signal, and transmits it via CAN communication.  |

# SYSTEM

## < SYSTEM DESCRIPTION >

| Signal name                 | Input           | Output         | Description   |
|-----------------------------|-----------------|----------------|---|
| Stop lamp switch signal     | Stop lamp relay | TCM (CAN)      | Inputs the stop lamp switch 1 signal and stop lamp switch 2 signal, and transmits it via CAN communication. |
| Interlock/PNP switch signal | TCM             | IPDM E/R (CAN) | Inputs the P/N position signal and transmits Interlock/PNP switch signal via CAN communication.             |

## POWER CONSUMPTION CONTROL SYSTEM

### POWER CONSUMPTION CONTROL SYSTEM : System Description

INFOID:0000000011324307

### SYSTEM DIAGRAM

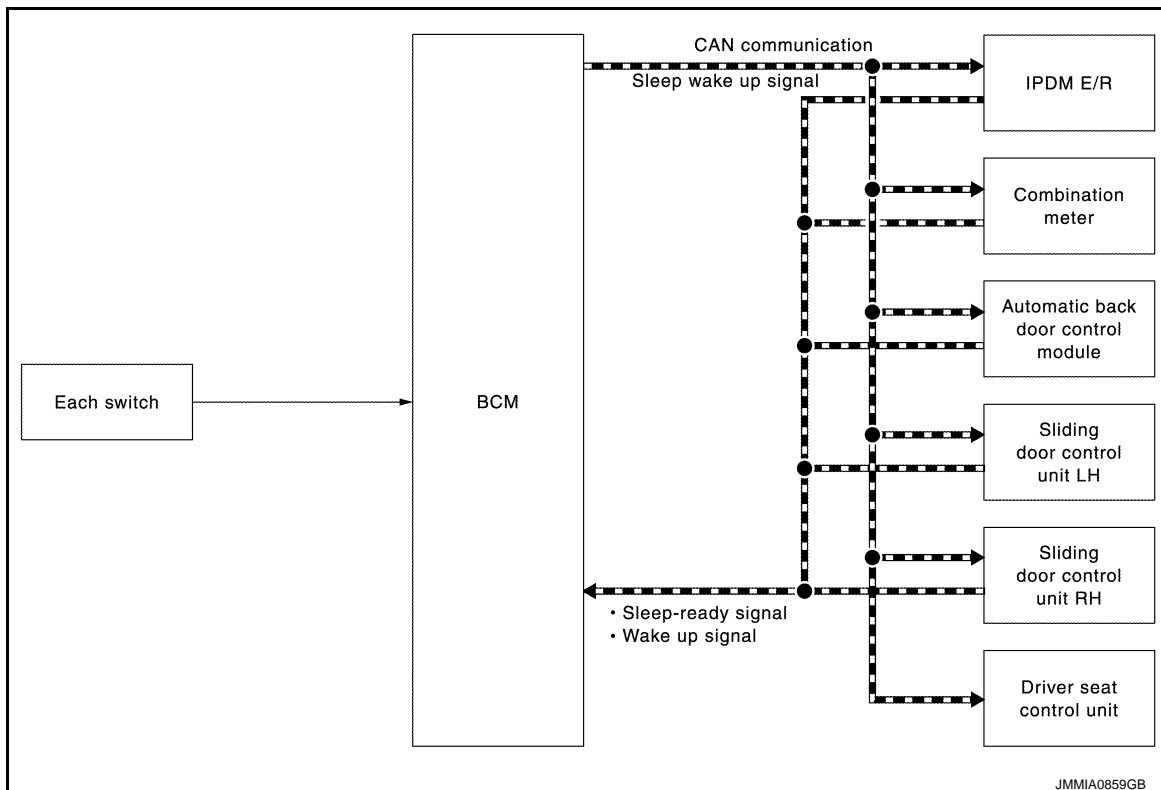

### OUTLINE

- BCM incorporates a power saving control function that reduces the power consumption according to the vehicle status.
- BCM switches the status (control mode) by itself with the power saving control function. It performs the sleep request to each unit (IPDM E/R, combination meter, driver seat control unit, automatic back door control module, sliding door control unit LH and sliding door control unit RH) that operates with the ignition switch OFF.

#### Normal mode (wake-up)

- CAN communication is normally performed with other units
- Each control with BCM is operating properly

#### CAN communication sleep mode (CAN sleep)

- CAN transmission is stopped
- Control with BCM only is operating

#### Low power consumption mode (BCM sleep)

- Low power consumption control is active
- CAN transmission is stopped

### LOW POWER CONSUMPTION CONTROL WITH BCM

A  
B  
C  
D  
E  
F  
G  
H  
I  
J  
K  
L

BCS

N

O

P

# SYSTEM

## < SYSTEM DESCRIPTION >

BCM reduces the power consumption with the following operation in the low power consumption mode.

- The reading interval of the each switches changes from 10 ms interval to 60 ms interval.

### Sleep mode activation

- BCM receives the sleep-ready signal (ready) from IPDM E/R, combination meter, automatic back door control module, sliding door control unit LH and sliding door control unit RH via CAN communication.
- BCM transmits the sleep wake up signal (sleep) to each unit when all of the CAN sleep conditions are fulfilled.
- Each unit stops the transmission of CAN communication with the sleep wake up signal. BCM is in CAN communication sleep mode.
- BCM is in the low power consumption mode and perform the low power consumption control when all of the BCM sleep conditions are fulfilled with CAN sleep condition.

### Sleep condition

| CAN sleep condition   | BCM sleep condition  |
|---|--|
| <ul style="list-style-type: none"><li>• Receiving the sleep-ready signal (ready) from all units</li><li>• Ignition switch: OFF</li><li>• Vehicle security system: Not operation</li><li>• Warning chime: Not operation</li><li>• Intelligent Key system buzzer: Not operation</li><li>• Stop lamp switch: OFF</li><li>• Turn signal indicator lamp: Not operation</li><li>• Exterior lamp: OFF</li><li>• Door lock status: No change</li><li>• CONSULT communication status: Not communication</li><li>• Meter display signal: Non-transmission</li><li>• Door switch status: No change</li><li>• Rear window defogger: OFF</li></ul> | <ul style="list-style-type: none"><li>• Interior room lamp battery saver: Time out*</li><li>• RAP system: OFF</li><li>• NVIS: Not operation</li><li>• Remote keyless entry receiver communication status: No communication</li><li>• LOCK indicator lamp: Not operation</li><li>• ACC indicator lamp: Not operation</li><li>• ON indicator lamp: Not operation</li></ul> |

### NOTE:

\*: Refer to [INL-11, "INTERIOR ROOM LAMP BATTERY SAVER SYSTEM : System Description"](#) for details of the interior room lamp battery saver time.

### Wake-up operation

- BCM transmits sleep wake up signal (wake up) to each unit when any condition listed below is established, and then goes into normal mode from low power consumption mode.
- Each unit starts transmissions with CAN communication by receiving sleep wake up signals. Each unit transmit wake up signals to BCM with CAN communication to convey the start of CAN communication.

# SYSTEM

## < SYSTEM DESCRIPTION >

| Wake-up condition                 |  | A |
|-----------------------------------|--|---|
| BCM wake-up condition             | CAN wake-up condition  |   |
|                                   | <ul style="list-style-type: none"> <li>• Receiving the sleep-ready signal (Not-ready) from any units</li> <li>• Push-button ignition switch (push switch): OFF → ON</li> <li>• Hazard switch: ON</li> </ul>  | B |
|                                   | <ul style="list-style-type: none"> <li>• HI BEAM switch: OFF → ON, ON → OFF</li> <li>• PASSING switch: OFF → ON, ON → OFF</li> <li>• HEADLAMP 1 switch: OFF → ON, ON → OFF</li> <li>• HEADLAMP 2 switch: OFF → ON, ON → OFF</li> <li>• TAIL LAMP switch: OFF → ON</li> <li>• FR FOG switch: OFF → ON, ON → OFF</li> <li>• TURN RH: OFF → ON</li> <li>• TURN LH: OFF → ON</li> </ul>  | C |
|                                   | <ul style="list-style-type: none"> <li>• Driver door switch: OFF → ON, ON → OFF</li> <li>• Passenger door switch: OFF → ON, ON → OFF</li> <li>• Rear RH door switch: OFF → ON, ON → OFF</li> <li>• Rear LH door switch: OFF → ON, ON → OFF</li> <li>• Back door switch: OFF → ON, ON → OFF</li> <li>• Driver door request switch: OFF → ON</li> <li>• Passenger door request switch: OFF → ON</li> <li>• Back door request switch: OFF → ON</li> <li>• Stop lamp switch: ON</li> <li>• Door lock and unlock switch: NEUTRAL → LOCK, NEUTRAL → UNLOCK</li> <li>• Front door lock assembly (driver side) (door key cylinder switch): NEUTRAL → LOCK, NEUTRAL → UNLOCK</li> <li>• Remote keyless entry receiver communication: Receiving</li> <li>• Front door lock assembly (driver side) (unlock sensor): OFF → ON, ON → OFF</li> </ul> | D |
| Back door opener switch: OFF → ON |  | E |
|                                   |  | F |
|                                   |  | G |
|                                   |  | H |
|                                   |  | I |
|                                   |  | J |
|                                   |  | K |
|                                   |  | L |
|                                   |  | M |
|                                   |  | N |
|                                   |  | O |
|                                   |  | P |

BCS

## DIAGNOSIS SYSTEM (BCM)

< SYSTEM DESCRIPTION >

### DIAGNOSIS SYSTEM (BCM)

#### COMMON ITEM

#### COMMON ITEM : CONSULT Function (BCM - COMMON ITEM)

INFOID:000000011324308

#### APPLICATION ITEM

CONSULT performs the following functions via CAN communication with BCM.

| Diagnosis mode           | Function Description  |
|--------------------------|---|
| Work Support             | Changes the setting for each system function.   |
| Self Diagnostic Result   | Displays the diagnosis results judged by BCM.   |
| CAN Diag Support Monitor | Monitors the reception status of CAN communication viewed from BCM.   |
| Data Monitor             | The BCM input/output signals are displayed.   |
| Active Test              | The signals used to activate each device are forcibly supplied from BCM.  |
| Ecu Identification       | The BCM part number is displayed.   |
| Configuration            | <ul style="list-style-type: none"> <li>• Read and save the vehicle specification.</li> <li>• Write the vehicle specification when replacing BCM.</li> </ul> |

#### SYSTEM APPLICATION

BCM can perform the following functions for each system.

#### NOTE:

It can perform the diagnosis modes except the following for all sub system selection items.

×: Applicable item

| System  | Sub system selection item | Diagnosis mode |              |             |
|---|---------------------------|----------------|--------------|-------------|
|   |                           | Work Support   | Data Monitor | Active Test |
| Door lock   | DOOR LOCK                 | ×              | ×            | ×           |
| Rear window defogger  | REAR DEFOGGER             |                | ×            | ×           |
| Warning chime   | BUZZER                    |                | ×            | ×           |
| Interior room lamp control system   | INT LAMP                  | ×              | ×            | ×           |
| Exterior lamp   | HEAD LAMP                 | ×              | ×            | ×           |
| Wiper and washer  | WIPER                     | ×              | ×            | ×           |
| Turn signal and hazard warning lamps  | FLASHER                   | ×              | ×            | ×           |
| Air conditioning control system   | AIR CONDITONER            |                | ×            | ×*          |
| <ul style="list-style-type: none"> <li>• Intelligent Key system</li> <li>• Engine start system</li> </ul> | INTELLIGENT KEY           | ×              | ×            | ×           |
| Combination switch  | COMB SW                   |                | ×            |             |
| Body control system   | BCM                       | ×              |              |             |
| NVIS  | IMMU                      | ×              | ×            | ×           |
| Interior room lamp battery saver  | BATTERY SAVER             | ×              | ×            | ×           |
| Back door open  | TRUNK                     |                | ×            |             |
| Vehicle security system   | THEFT ALM                 | ×              | ×            | ×           |
| RAP system  | RETAINED PWR              |                | ×            |             |
| Signal buffer system  | SIGNAL BUFFER             |                | ×            | ×           |
| TPMS  | AIR PRESSURE MONITOR      | ×              | ×            | ×           |

#### NOTE:

\*: For models with automatic air conditioning control system, this diagnosis mode is not used.

#### FREEZE FRAME DATA (FFD)

The BCM records the following vehicle condition at the time a particular DTC is detected, and displays on CONSULT.



# DIAGNOSIS SYSTEM (BCM)

## < SYSTEM DESCRIPTION >

| CONSULT screen item | Indication/Unit                | Description  |   |   |
|---------------------|--------------------------------|--|---|---|
| Vehicle Speed       | km/h                           | Vehicle speed of the moment a particular DTC is detected   |   | A |
| Odo/Trip Meter      | km                             | Total mileage (Odometer value) of the moment a particular DTC is detected  |   |   |
| Vehicle Condition   | SLEEP>LOCK                     | Power position status of the moment a particular DTC is detected*  | While turning BCM status from low power consumption mode to normal mode [Power supply position is OFF (LOCK)] | B |
|                     | SLEEP>OFF                      |  | While turning BCM status from low power consumption mode to normal mode [Power supply position is OFF (OFF)]  | C |
|                     | LOCK>ACC                       |  | While turning power supply position from OFF (LOCK) to ACC  |   |
|                     | ACC>ON                         |  | While turning power supply position from ACC to ON  | D |
|                     | RUN>ACC                        |  | While turning power supply position from RUN to ACC (Except emergency stop operation)                         |   |
|                     | CRANK>RUN                      |  | While turning power supply position from CRANK to RUN   | E |
|                     | RUN>URGENT                     |  | While turning power supply position from RUN to ACC (Emergency stop operation)                                |   |
|                     | ACC>OFF                        |  | While turning power supply position from ACC to OFF (OFF)   | F |
|                     | OFF>LOCK                       |  | While turning power supply position from OFF (OFF) to OFF (LOCK)  |   |
|                     | OFF>ACC                        |  | While turning power supply position from OFF (OFF) to ACC   | G |
|                     | ON>CRANK                       |  | While turning power supply position from ON to CRANK  |   |
|                     | OFF>SLEEP                      |  | While turning BCM status from normal mode [Power supply position is OFF (OFF)] to low power consumption mode  | H |
|                     | LOCK>SLEEP                     |  | While turning BCM status from normal mode [Power supply position is OFF (LOCK)] to low power consumption mode |   |
|                     | LOCK                           |  | Power supply position is OFF (LOCK)   | I |
|                     | OFF                            |  | Power supply position is OFF (OFF)  |   |
|                     | ACC                            |  | Power supply position is ACC  | J |
|                     | ON                             |  | Power supply position is ON   |   |
| ENGINE RUN          | Power supply position is RUN   | K  |   |   |
| CRANKING            | Power supply position is CRANK |  |   |   |
| IGN Counter         | 0 - 39                         | The number of times that ignition switch is turned ON after DTC is detected <ul style="list-style-type: none"> <li>• The number is 0 when a malfunction is detected now.</li> <li>• The number increases like 1 → 2 → 3...38 → 39 after returning to the normal condition whenever ignition switch OFF → ON.</li> <li>• The number is fixed to 39 until the self-diagnosis results are erased if it is over 39.</li> </ul> |   | L |

### NOTE:

\*: Refer to the following for details of the power supply position.

- OFF (OFF, LOCK): Ignition switch OFF
- ACC: Ignition switch ACC
- IGN: Ignition switch ON with engine stopped
- RUN: Ignition switch ON with engine running
- CRANK: At engine cranking

Power supply position shifts to "OFF (LOCK)" from "OFF (OFF)", when ignition switch is in the OFF position, shift position is in the P position, and any of the following conditions are met.

- Closing door
- Opening door
- Door is locked using door request switch
- Door is locked using Intelligent Key

The power supply position shifts to "ACC" when the push-button ignition switch (push switch) is pushed at "OFF (LOCK)".

## DOOR LOCK

BCS

N

O

P

# DIAGNOSIS SYSTEM (BCM)

< SYSTEM DESCRIPTION >

## DOOR LOCK : CONSULT Function (BCM - DOOR LOCK)

INFOID:000000011561484

### BCM CONSULT FUNCTION

CONSULT performs the following functions via CAN communication with BCM.

### WORK SUPPORT

| Monitor item                 | Description  |
|------------------------------|--|
| DOOR LOCK-UNLOCK SET         | Selective unlock function mode can be changed to operation with this mode <ul style="list-style-type: none"> <li>• On: Operate</li> <li>• Off: Non-operation</li> </ul>  |
| AUTOMATIC DOOR LOCK SELECT   | Automatic door lock function mode can be selected from the following in this mode <ul style="list-style-type: none"> <li>• VH SPD: All doors are locked when vehicle speed more than 24 km/h (15 MPH)</li> <li>• P RANGE: All doors are locked when shifting the selector lever from P position to other than the P position</li> </ul>  |
| AUTOMATIC DOOR UNLOCK SELECT | Automatic door unlock function mode can be selected from the following in this mode <ul style="list-style-type: none"> <li>• MODE 1: All doors are unlocked when the power supply position is changed from ON to OFF</li> <li>• MODE 2: All doors are unlocked when shifting the selector lever from any position other than the P to P position</li> <li>• MODE 3: Driver side door is unlocked when the power supply position is changed from ON to OFF</li> <li>• MODE 4: Driver side door is unlocked when shifting the selector lever from any position other than the P to P position</li> <li>• MODE 5: This item is displayed, but cannot be used</li> <li>• MODE 6: This item is displayed, but cannot be used</li> </ul> |
| AUTOMATIC LOCK/UNLOCK SET    | Automatic door lock/unlock function mode can be selected from the following in this mode <ul style="list-style-type: none"> <li>• Off: Non-operation</li> <li>• Unlock Only: Door unlock operation only</li> <li>• Lock Only: Door lock operation only</li> <li>• Lock/Unlock: Lock and unlock operation</li> </ul>  |

### DATA MONITOR

#### NOTE:

The following table includes information (items) inapplicable to this vehicle. For information (items) applicable to this vehicle, refer to CONSULT display items.

| Monitor Item  | Contents  |
|---------------|---|
| REQ SW-DR     | Indicated [On/Off] condition of door request switch (driver side)           |
| REQ SW-AS     | Indicated [On/Off] condition of door request switch (passenger side)        |
| REQ SW-BD/TR  | Indicated [On/Off] condition of back door request switch                    |
| DOOR SW-DR    | Indicated [On/Off] condition of front door switch (driver side)             |
| DOOR SW-AS    | Indicated [On/Off] condition of front door switch (passenger side)          |
| DOOR SW-RR    | Indicated [On/Off] condition of sliding door switch RH                      |
| DOOR SW-RL    | Indicated [On/Off] condition of sliding door switch LH                      |
| DOOR SW-BK    | Indicated [On/Off] condition of back door switch                            |
| CDL LOCK SW   | Indicated [On/Off] condition of lock signal from door lock unlock switch    |
| CDL UNLOCK SW | Indicated [On/Off] condition of unlock signal from door lock unlock switch  |
| KEY CYL LK-SW | Indicated [On/Off] condition of lock signal from door key cylinder switch   |
| KEY CYL UN-SW | Indicated [On/Off] condition of unlock signal from door key cylinder switch |

### ACTIVE TEST

# DIAGNOSIS SYSTEM (BCM)

## < SYSTEM DESCRIPTION >

| Test item | Description  |
|-----------|--|
| DOOR LOCK | <p>This test is able to check door lock/unlock operation</p> <ul style="list-style-type: none"> <li>• The all door lock actuators are locked when "ALL LOCK" on CONSULT screen is touched</li> <li>• The all door lock actuators are unlocked when "ALL UNLK" on CONSULT screen is touched</li> <li>• The front door lock actuator (driver side) is unlocked when "DR UNLK" on CONSULT screen is touched</li> <li>• The front door lock actuator (passenger side) is unlocked when "AS UNLK" on CONSULT screen is touched</li> <li>• The door lock actuator (other) is unlocked when "OTR ULK" on CONSULT screen is touched</li> </ul> |

## REAR WINDOW DEFOGGER

### REAR WINDOW DEFOGGER : CONSULT Function (BCM - REAR DEFOGGER)

INFOID:000000011561499

#### DATA MONITOR

##### NOTE:

The following table includes information (items) inapplicable to this vehicle. For information (items) applicable to this vehicle, refer to CONSULT display items.

| Monitor Item | Description   |
|--------------|---|
| REAR DEF SW  | Displays "Press (ON)/other (OFF)" status determined with the rear window defogger switch. |
| PUSH SW      | Indicates [ON/OFF] condition of push switch.  |

#### ACTIVE TEST

| Test Item     | Description   |
|---------------|---|
| REAR DEFOGGER | Rear window defogger operates when ON on CONSULT screen is touched. |

## BUZZER

### BUZZER : CONSULT Function (BCM - BUZZER)

INFOID:000000011561500

#### CONSULT APPLICATION ITEMS

| Test item | Diagnosis mode | Description   |
|-----------|----------------|---|
| BUZZER    | Data Monitor   | Displays BCM input data in real time.   |
|           | Active Test    | Operation of electrical loads can be checked by sending driving signal to them. |

#### DATA MONITOR

##### NOTE:

The following table includes information (items) inapplicable to this vehicle. For information (items) applicable to this vehicle, refer to CONSULT display items.

| Display item<br>[Unit]   | Description  |
|--------------------------|--|
| PUSH SW<br>[On/Off]      | Status of push-button ignition switch judged by BCM.   |
| UNLK SEN-DR<br>[On/Off]  | Status of unlock sensor judged by BCM.   |
| VEH SPEED 1<br>[km/h]    | Value of vehicle speed signal received from combination meter with CAN communication line.   |
| TAIL LAMP SW<br>[On/Off] | Status of lighting switch judged by BCM using the combination switch readout function.       |
| FR FOG SW<br>[On/Off]    | Status of front fog lamp switch judged by BCM using the combination switch readout function. |

A

B

C

D

E

F

G

H

I

J

K

L

BCS

N

O

P

# DIAGNOSIS SYSTEM (BCM)

## < SYSTEM DESCRIPTION >

| Display item<br>[Unit]  | Description                                      |
|-------------------------|--|
| DOOR SW-DR<br>[On/Off]  | Status of driver side door switch judged by BCM. |
| CDL LOCK SW<br>[On/Off] | Status of door lock unlock switch judged by BCM. |

## ACTIVE TEST

| Display item<br>[Unit] | Description   |
|------------------------|---|
| SEAT BELT WARN TEST    | The seat belt warning chime operation can be checked by operating the relevant function (On/Off). |
| ID REGIST WARNING      | The ID regist warning chime operation can be checked by operating the relevant function (On/Off). |
| LIGHT WARN ALM         | The light warning chime operation can be checked by operating the relevant function (On/Off).     |

## INT LAMP

### INT LAMP : CONSULT Function (BCM - INT LAMP)

INFOID:000000011561496

## WORK SUPPORT

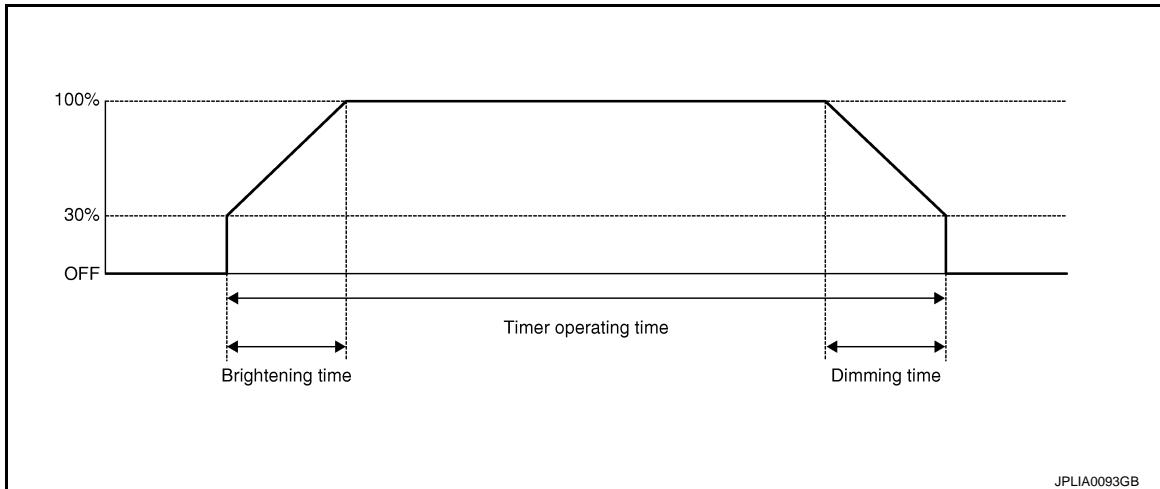

| Service item           | Setting item | Setting                                       | Setting   |
|------------------------|--------------|---|---|
| ROOM LAMP TIMER SET    | MODE 2       | 7.5 sec.                                      | Sets the interior room lamp ON time. (Timer operating time) |
|                        | MODE 3*      | 15 sec.                                       |   |
|                        | MODE 4       | 30 sec.                                       |   |
| SET I/L D-UNLCK INTCON | On*          | With the interior room lamp timer function    |   |
|                        | Off          | Without the interior room lamp timer function |   |
| ROOM LAMP ON TIME SET  | MODE 1       | 0.5 sec.                                      | Sets the interior room lamp gradual brightening time.       |
|                        | MODE 2*      | 1 sec.  |   |
|                        | MODE 3       | 2 sec.  |   |
|                        | MODE 4       | 3 sec.  |   |
|                        | MODE 5       | 0 sec.  |   |
| ROOM LAMP OFF TIME SET | MODE 1       | 0.5 sec.                                      | Sets the interior room lamp gradual dimming time.           |
|                        | MODE 2*      | 1 sec.  |   |
|                        | MODE 3       | 2 sec.  |   |
|                        | MODE 4       | 3 sec.  |   |
|                        | MODE 5       | 0 sec.  |   |

# DIAGNOSIS SYSTEM (BCM)

## < SYSTEM DESCRIPTION >

| Service item           | Setting item | Setting   |
|------------------------|--------------|---|
| R LAMP TIMER LOGIC SET | MODE 1*      | Interior room lamp timer activates with synchronizing all doors.            |
|                        | MODE 2       | Interior room lamp timer activates with synchronizing the driver door only. |

\*: Factory setting

## DATA MONITOR

### NOTE:

The following table includes information (items) inapplicable to this vehicle. For information (items) applicable to this vehicle, refer to CONSULT display items.

| Monitor item<br>[Unit]    | Description   |
|---------------------------|---|
| REQ SW-DR<br>[On/Off]     | The switch status input from door request switch (driver side)    |
| REQ SW-AS<br>[On/Off]     | The switch status input from door request switch (passenger side) |
| REQ SW-RR<br>[On/Off]     | <b>NOTE:</b><br>The item is indicated, but not monitored.         |
| REQ SW-RL<br>[On/Off]     |   |
| PUSH SW<br>[On/Off]       | The switch status input from push-button ignition switch          |
| UNLK SEN -DR<br>[On/Off]  | Driver door unlock status input from unlock sensor                |
| DOOR SW-DR<br>[On/Off]    | The switch status input from front door switch (driver side)      |
| DOOR SW-AS<br>[On/Off]    | The switch status input from front door switch (passenger side)   |
| DOOR SW-RR<br>[On/Off]    | The switch status input from sliding door switch RH               |
| DOOR SW- RL<br>[On/Off]   | The switch status input from sliding door switch LH               |
| DOOR SW- BK<br>[On/Off]   | The switch status input from back door switch                     |
| CDL LOCK SW<br>[On/Off]   | Lock switch status input from door lock and unlock switch         |
| CDL UNLOCK SW<br>[On/Off] | Unlock switch status input from door lock and unlock switch       |
| TRNK/HAT MNTR<br>[On/Off] | <b>NOTE:</b><br>The item is indicated, but not monitored          |
| KEY CYL LK-SW<br>[On/Off] | Lock switch status received from door key cylinder switch         |
| KEY CYL UN-SW<br>[On/Off] | Unlock switch status received from door key cylinder switch       |
| RKE-LOCK<br>[On/Off]      | Lock signal status received from remote keyless entry receiver    |
| RKE-UNLOCK<br>[On/Off]    | Unlock signal status received from remote keyless entry receiver  |

## ACTIVE TEST

# DIAGNOSIS SYSTEM (BCM)

## < SYSTEM DESCRIPTION >

| Test item      | Operation | Description   |
|----------------|-----------|---|
| INT LAMP       | On        | Outputs the interior room lamp control signal to turn the interior room lamps ON. [Map lamp, personal lamp (when applicable lamps switch is in DOOR position.)] |
|                | Off       | Stops the interior room lamp control signal to turn the interior room lamps.  |
| STEP LAMP TEST | On        | Outputs the step lamp control signal to turn the step lamps ON.   |
|                | Off       | Stops the step lamp control signal to turn the step lamps ON.   |

## HEADLAMP

### HEADLAMP : CONSULT Function (BCM - HEADLAMP) (Xenon Type Headlamp)

INFOID:000000011561492

## WORK SUPPORT

| Service item             | Setting item | Setting   |
|--------------------------|--------------|---|
| CUSTOM A/LIGHT SETTING*1 | MODE 1*3     | Normal  |
|                          | MODE 2       | More sensitive setting than normal setting (Turns ON earlier than normal operation) |
|                          | MODE 3       | More sensitive setting than MODE 2 (Turns ON earlier than MODE 2)                   |
|                          | MODE 4       | Less sensitive setting than normal setting (Turns ON later than normal operation.)  |
| BATTERY SAVER SET        | On*3         | With the exterior lamp battery saver function                                       |
|                          | Off          | Without the exterior lamp battery saver function                                    |
| ILL DELAY SET*1          | MODE 1*3     | 45 sec.   |
|                          | MODE 2       | Without the function  |
|                          | MODE 3       | 30 sec.   |
|                          | MODE 4       | 60 sec.   |
|                          | MODE 5       | 90 sec.   |
|                          | MODE 6       | 120 sec.  |
|                          | MODE 7       | 150 sec.  |
|                          | MODE 8       | 180 sec.  |
|                          |              | Sets delay timer function timer operation time. (All doors closed)                  |
| AUTO LIGHT LOGIC SET*2   | MODE 1*3     | With twilight ON custom & with wiper INT, LO and HI                                 |
|                          | MODE 2       | With twilight ON custom & with wiper LO and HI                                      |
|                          | MODE 3       | With twilight ON custom & without   |
|                          | MODE 4       | Without twilight ON custom & with wiper INT, LO and HI                              |
|                          | MODE 5       | Without twilight ON custom & with wiper LO and HI                                   |
|                          | MODE 6       | Without twilight ON custom & without  |

\*1: For models without auto light system, this item is displayed but is not operated.

\*2: For models without auto light system and all models for Canada, this item is displayed but is not operated.

\*3: Factory setting

## DATA MONITOR

### NOTE:

The following table includes information (items) inapplicable to this vehicle. For information (items) applicable to this vehicle, refer to CONSULT display items.

# DIAGNOSIS SYSTEM (BCM)

## < SYSTEM DESCRIPTION >

| Monitor item<br>[Unit]                 | Description  | A  |
|--|--|--|
| PUSH SW<br>[On/Off]                    | The switch status input from push-button ignition switch                             | B  |
| ENGINE STATE<br>[Stop/Stall/Crank/Run] | The engine status received from ECM with CAN communication                           | C  |
| VEH SPEED 1<br>[km/h]                  | The value of the vehicle speed received from combination meter via CAN communication | D  |
| TURN SIGNAL R<br>[On/Off]              | Each switch status that BCM judges from the combination switch reading function      | E  |
| TURN SIGNAL L<br>[On/Off]              |  | F  |
| TAIL LAMP SW<br>[On/Off]               |  | G  |
| HI BEAM SW<br>[On/Off]                 |  | H  |
| HEAD LAMP SW1<br>[On/Off]              |  | I  |
| HEAD LAMP SW2<br>[On/Off]              |  | J  |
| PASSING SW<br>[On/Off]                 |  | K  |
| AUTO LIGHT SW*1<br>[On/Off]            |  | L  |
| FR FOG SW*2<br>[On/Off]                |  | M  |
| DOOR SW-DR<br>[On/Off]                 |  | The switch status input from front door switch (driver side) |
| DOOR SW-AS<br>[On/Off]                 | The switch status input from front door switch (passenger side)                      | O  |
| DOOR SW-RR<br>[On/Off]                 | The switch status input from sliding door switch RH                                  | P  |
| DOOR SW- RL<br>[On/Off]                | The switch status input from sliding door switch LH                                  | Q  |
| DOOR SW-BK<br>[On/Off]                 | The switch status input from back door switch  | R  |
| OPTICAL SENSOR<br>[On/Off/NG]          | <b>NOTE:</b><br>This item is indicated, but can not monitored                        | S  |
| OPTI SEN (DTCT)*1<br>[V]               | The value of outside brightness voltage input from the optical sensor                | T  |
| OPTI SEN (FILT)*1<br>[V]               | The value of outside brightness voltage filtered by BCM                              | U  |

\*1: For models without auto light system, this item is not displayed.

\*2: For models without front fog lamp, this item is displayed but is not monitored.

## ACTIVE TEST

| Test item | Operation | Description  |
|-----------|-----------|--|
| TAIL LAMP | On        | Transmits the position light request signal to IPDM E/R via CAN communication to turn the tail lamp ON |
|           | Off       | Stops the tail lamp request signal transmission  |

# DIAGNOSIS SYSTEM (BCM)

## < SYSTEM DESCRIPTION >

| Test item               | Operation | Description  |
|-------------------------|-----------|--|
| HEAD LAMP               | Hi        | Transmits the high beam request signal via CAN communication to turn the headlamp (HI)   |
|                         | Lo        | Transmits the low beam request signal via CAN communication to turn the headlamp (LO)  |
|                         | Off       | Stops the high & low beam request signal transmission  |
| FR FOG LAMP*1           | On        | Transmits the front fog light request signal to IPDM E/R via CAN communication to turn the front fog lamp ON   |
|                         | Off       | Stops the front light request signal transmission  |
| DAYTIME RUNNING LIGHT*2 | On        | Transmits the daytime running light request signal via CAN communication to IPDM E/R   |
|                         | Off       | Stop the daytime running light request signal transmission   |
| ILL DIM SIGNAL          | On        | <ul style="list-style-type: none"> <li>Transmits the dimmer signal to combination meter via CAN communication and dims combination meter*3</li> <li>Transmits the dimmer signal to AV control unit and dims display</li> </ul> |
|                         | Off       | Stops the dimmer signal transmission   |

\*1: For models without front fog lamp, this item is displayed but is not tested.

\*2: For models without daytime running light system, this item is not displayed.

\*3: Except for CANADA

## HEADLAMP : CONSULT Function (BCM - HEADLAMP) (Halogen Type Headlamp)

INFOID:000000011561493

## WORK SUPPORT

| Service item             | Setting item | Setting   |
|--------------------------|--------------|---|
| CUSTOM A/LIGHT SETTING*1 | MODE 1*3     | Normal  |
|                          | MODE 2       | More sensitive setting than normal setting (Turns ON earlier than normal operation) |
|                          | MODE 3       | More sensitive setting than MODE 2 (Turns ON earlier than MODE 2)                   |
|                          | MODE 4       | Less sensitive setting than normal setting (Turns ON later than normal operation.)  |
| BATTERY SAVER SET        | On*3         | With the exterior lamp battery saver function                                       |
|                          | Off          | Without the exterior lamp battery saver function                                    |
| ILL DELAY SET*1          | MODE 1*3     | 45 sec.   |
|                          | MODE 2       | Without the function  |
|                          | MODE 3       | 30 sec.   |
|                          | MODE 4       | 60 sec.   |
|                          | MODE 5       | 90 sec.   |
|                          | MODE 6       | 120 sec.  |
|                          | MODE 7       | 150 sec.  |
|                          | MODE 8       | 180 sec.  |
|                          |              | Sets delay timer function timer operation time. (All doors closed)                  |
| AUTO LIGHT LOGIC SET*2   | MODE 1*3     | With twilight ON custom & with wiper INT, LO and HI                                 |
|                          | MODE 2       | With twilight ON custom & with wiper LO and HI                                      |
|                          | MODE 3       | With twilight ON custom & without   |
|                          | MODE 4       | Without twilight ON custom & with wiper INT, LO and HI                              |
|                          | MODE 5       | Without twilight ON custom & with wiper LO and HI                                   |
|                          | MODE 6       | Without twilight ON custom & without  |

\*1: For models without auto light system, this item is displayed but is not operated.



# DIAGNOSIS SYSTEM (BCM)

## < SYSTEM DESCRIPTION >

\*2: For models without auto light system and all models for Canada, this item is displayed but is not operated.

\*3: Factory setting

### DATA MONITOR

#### NOTE:

The following table includes information (items) inapplicable to this vehicle. For information (items) applicable to this vehicle, refer to CONSULT display items.

| Monitor item<br>[Unit]                 | Description  |
|--|--|
| PUSH SW<br>[On/Off]                    | The switch status input from push-button ignition switch                             |
| ENGINE STATE<br>[Stop/Stall/Crank/Run] | The engine status received from ECM with CAN communication                           |
| VEH SPEED 1<br>[km/h]                  | The value of the vehicle speed received from combination meter via CAN communication |
| TURN SIGNAL R<br>[On/Off]              | Each switch status that BCM judges from the combination switch reading function      |
| TURN SIGNAL L<br>[On/Off]              |  |
| TAIL LAMP SW<br>[On/Off]               |  |
| HI BEAM SW<br>[On/Off]                 |  |
| HEAD LAMP SW1<br>[On/Off]              |  |
| HEAD LAMP SW2<br>[On/Off]              |  |
| PASSING SW<br>[On/Off]                 |  |
| AUTO LIGHT SW*1<br>[On/Off]            |  |
| FR FOG SW*2<br>[On/Off]                |  |
| DOOR SW-DR<br>[On/Off]                 |  |
| DOOR SW-AS<br>[On/Off]                 | The switch status input from front door switch (passenger side)                      |
| DOOR SW-RR<br>[On/Off]                 | The switch status input from sliding door switch RH                                  |
| DOOR SW- RL<br>[On/Off]                | The switch status input from sliding door switch LH                                  |
| DOOR SW-BK<br>[On/Off]                 | The switch status input from back door switch  |
| OPTICAL SENSOR<br>[On/Off/NG]          | <b>NOTE:</b><br>This item is indicated, but can not monitored                        |
| OPTI SEN (DTCT)*1<br>[V]               | The value of outside brightness voltage input from the optical sensor                |
| OPTI SEN (FILT)*1<br>[V]               | The value of outside brightness voltage filtered by BCM                              |

\*1: For models without auto light system, this item is not displayed.

\*2: For models without front fog lamp, this item is displayed but is not monitored.

### ACTIVE TEST

A  
B  
C  
D  
E  
F  
G  
H  
I  
J  
K  
L  
N  
O  
P

BCS

# DIAGNOSIS SYSTEM (BCM)

## < SYSTEM DESCRIPTION >

| Test item               | Operation | Description  |
|-------------------------|-----------|--|
| TAIL LAMP               | On        | Transmits the position light request signal to IPDM E/R via CAN communication to turn the tail lamp ON   |
|                         | Off       | Stops the tail lamp request signal transmission  |
| HEAD LAMP               | Hi        | Transmits the high beam request signal via CAN communication to turn the headlamp (HI)   |
|                         | Lo        | Transmits the low beam request signal via CAN communication to turn the headlamp (LO)  |
|                         | Off       | Stops the high & low beam request signal transmission  |
| FR FOG LAMP*1           | On        | Transmits the front fog light request signal to IPDM E/R via CAN communication to turn the front fog lamp ON   |
|                         | Off       | Stops the front light request signal transmission  |
| DAYTIME RUNNING LIGHT*2 | On        | Transmits the daytime running light request signal via CAN communication to IPDM E/R   |
|                         | Off       | Stop the daytime running light request signal transmission   |
| ILL DIM SIGNAL          | On        | <ul style="list-style-type: none"> <li>Transmits the dimmer signal to combination meter via CAN communication and dims combination meter*3</li> <li>Transmits the dimmer signal to AV control unit and dims display</li> </ul> |
|                         | Off       | Stops the dimmer signal transmission   |

\*1: For models without front fog lamp, this item is displayed but is not tested.

\*2: For models without daytime running light system, this item is not displayed.

\*3: Except for CANADA

## WIPER

### WIPER : CONSULT Function (BCM - WIPER)

INFOID:000000011561498

## WORK SUPPORT

| Service item        | Setting item | Description  |
|---------------------|--------------|--|
| WIPER SPEED SETTING | On           | With vehicle speed<br>(Front wiper intermittent time linked with the vehicle speed and wiper intermittent dial position) |
|                     | Off*         | Without vehicle speed<br>(Front wiper intermittent time linked with the wiper intermittent dial position)                |

\*: Factory setting

## DATA MONITOR

### NOTE:

The following table includes information (items) inapplicable to this vehicle. For information (items) applicable to this vehicle, refer to CONSULT display items.

| Monitor Item<br>[Unit] | Description   |
|------------------------|---|
| PUSH SW<br>[Off/On]    | The switch status input from push-button ignition switch.   |
| VEH SPEED 1<br>[km/h]  | Displays the value of the vehicle speed signal received from combination meter via CAN communication. |

# DIAGNOSIS SYSTEM (BCM)

## < SYSTEM DESCRIPTION >

| Monitor Item<br>[Unit]    | Description   |
|---------------------------|---|
| FR WIPER HI<br>[Off/On]   | Status of each switch judged by BCM using the combination switch reading function                         |
| FR WIPER LOW<br>[Off/On]  |   |
| FR WASHER SW<br>[Off/On]  |   |
| FR WIPER INT<br>[Off/On]  |   |
| FR WIPER STOP<br>[Off/On] | Displays the status of the front wiper stop position signal received from IPDM E/R via CAN communication. |
| INT VOLUME<br>[1 - 7]     | Status of each switch judged by BCM using the combination switch reading function                         |
| RR WIPER ON<br>[Off/On]   | Status of each switch judged by BCM using the combination switch reading function                         |
| RR WIPER INT<br>[Off/On]  |   |
| RR WASHER SW<br>[Off/On]  |   |
| RR WIPER STOP<br>[Off/On] |   |
|                           | Rear wiper motor (stop position) status input from the rear wiper motor                                   |

## ACTIVE TEST

| Test item | Operation | Description  |
|-----------|-----------|--|
| FR WIPER  | Hi        | Transmits the front wiper request signal (HI) to IPDM E/R via CAN communication to operate the front wiper HI operation.   |
|           | Lo        | Transmits the front wiper request signal (LO) to IPDM E/R via CAN communication to operate the front wiper LO operation.   |
|           | INT       | Transmits the front wiper request signal (INT) to IPDM E/R via CAN communication to operate the front wiper INT operation. |
|           | Off       | Stops transmitting the front wiper request signal to stop the front wiper operation.                                       |
| RR WIPER  | On        | Output the voltage to operate the rear wiper motor.  |
|           | Off       | Stops the voltage to stop the rear wiper motor.  |

## FLASHER

### FLASHER : CONSULT Function (BCM - FLASHER) (Xenon Type Headlamp)

INFOID:000000011561494

BCS

## WORK SUPPORT

| Service item          | Setting item | Setting                |  |
|-----------------------|--------------|------------------------|--|
| HAZARD ANSWER<br>BACK | Lock Only    | With locking only      | Sets the hazard warning lamp answer back function when the door is lock/unlock with the request switch or the key fob. |
|                       | Unlk Only    | With unlocking only    |  |
|                       | Lock&Unlk*   | With locking/unlocking |  |
|                       | Off          | Without the function   |  |

\*: Factory setting

## DATA MONITOR

### NOTE:

The following table includes information (items) inapplicable to this vehicle. For information (items) applicable to this vehicle, refer to CONSULT display items.

# DIAGNOSIS SYSTEM (BCM)

## < SYSTEM DESCRIPTION >

| Monitor item<br>[Unit]    | Description  |
|---------------------------|--|
| REQ SW-DR<br>[On/Off]     | The switch status input from the request switch (driver side)                    |
| REQ SW-AS<br>[On/Off]     | The switch status input from the request switch (passenger side)                 |
| PUSH SW<br>[On/Off]       | The switch status input from the push-button ignition switch                     |
| TURN SIGNAL R<br>[On/Off] | Each switch status that BCM detects from the combination switch reading function |
| TURN SIGNAL L<br>[On/Off] |  |
| HAZARD SW<br>[On/Off]     | The switch status input from the hazard switch                                   |
| RKE-LOCK<br>[On/Off]      | Lock signal status received from the remote keyless entry receiver               |
| RKE-UNLOCK<br>[On/Off]    | Unlock signal status received from the remote keyless entry receiver             |
| RKE-PANIC<br>[On/Off]     | Panic alarm signal status received from the remote keyless entry receiver        |

## ACTIVE TEST

| Test item | Operation | Description  |
|-----------|-----------|--|
| FLASHER   | RH        | Outputs the voltage to turn on the right side turn signal lamps. |
|           | LH        | Outputs the voltage to turn on the left side turn signal lamps.  |
|           | Off       | Stops the voltage to turn the turn signal lamps OFF.             |

## FLASHER : CONSULT Function (BCM - FLASHER) (Halagen Type Headlamp)

INFOID:000000011561495

## WORK SUPPORT

| Service item          | Setting item | Setting  |
|-----------------------|--------------|--|
| HAZARD ANSWER<br>BACK | Lock Only    | With locking only  |
|                       | Unlk Only    | With unlocking only  |
|                       | Lock&Unlk*   | With locking/unlocking   |
|                       | Off          | Without the function   |
|                       |              | Sets the hazard warning lamp answer back function when the door is lock/unlock with the request switch or the key fob. |

\*: Factory setting

## DATA MONITOR

### NOTE:

The following table includes information (items) inapplicable to this vehicle. For information (items) applicable to this vehicle, refer to CONSULT display items.

| Monitor item<br>[Unit] | Description  |
|------------------------|--|
| REQ SW-DR<br>[On/Off]  | The switch status input from the request switch (driver side)    |
| REQ SW-AS<br>[On/Off]  | The switch status input from the request switch (passenger side) |
| PUSH SW<br>[On/Off]    | The switch status input from the push-button ignition switch     |

# DIAGNOSIS SYSTEM (BCM)

## < SYSTEM DESCRIPTION >

| Monitor item<br>[Unit]    | Description  |
|---------------------------|--|
| TURN SIGNAL R<br>[On/Off] | Each switch status that BCM detects from the combination switch reading function |
| TURN SIGNAL L<br>[On/Off] |  |
| HAZARD SW<br>[On/Off]     | The switch status input from the hazard switch                                   |
| RKE-LOCK<br>[On/Off]      | Lock signal status received from the remote keyless entry receiver               |
| RKE-UNLOCK<br>[On/Off]    | Unlock signal status received from the remote keyless entry receiver             |
| RKE-PANIC<br>[On/Off]     | Panic alarm signal status received from the remote keyless entry receiver        |

## ACTIVE TEST

| Test item | Operation | Description   |
|-----------|-----------|---|
| FLASHER   | RH        | Outputs the voltage to turn on the right side turn signal lamps.  |
|           | LH        | Outputs the voltage to blink turn on left side turn signal lamps. |
|           | Off       | Stops the voltage to turn the turn signal lamps OFF.              |

## AIR CONDITIONER

### AIR CONDITIONER : CONSULT Function (BCM - AIR CONDITIONER) (Auto A/C)

INFOID:000000011561481

#### DATA MONITOR

##### NOTE:

The following table includes information (items) inapplicable to this vehicle. For information (items) applicable to this vehicle, refer to CONSULT display items.

##### Display Item List

| Monitor Item [Unit]  | Contents  |
|----------------------|---|
| FAN ON SIG [On/Off]  | Displays the status of blower fan ON signal received from A/C auto amp. |
| AIR COND SW [On/Off] | Displays the status of A/C ON signal received from A/C auto amp.        |

### AIR CONDITIONER : CONSULT Function (BCM - AIR CONDITIONER) (Manual A/C)

INFOID:000000011561483

#### DATA MONITOR

##### NOTE:

The following table includes information (items) inapplicable to this vehicle. For information (items) applicable to this vehicle, refer to CONSULT display items.

##### Display Item List

| Monitor Item [Unit]  | Contents   |
|----------------------|--|
| FAN ON SIG [On/Off]  | Displays the status of blower fan ON signal received from A/C amp. |
| AIR COND SW [On/Off] | Displays the status of A/C ON signal received from A/C amp.        |

## INTELLIGENT KEY

### INTELLIGENT KEY : CONSULT Function (BCM - INTELLIGENT KEY)

INFOID:000000011561485

## WORK SUPPORT

A  
B  
C  
D  
E  
F  
G  
H  
I  
J  
K  
L

BCS

N  
O  
P

## DIAGNOSIS SYSTEM (BCM)

### < SYSTEM DESCRIPTION >

| Monitor item             | Description  |
|--------------------------|--|
| INSIDE ANT DIAGNOSIS     | This function allows inside key antenna self-diagnosis   |
| LOCK/UNLOCK BY I-KEY     | Door lock/unlock function by door request switch mode can be changed to operation in this mode <ul style="list-style-type: none"> <li>• On: Operate</li> <li>• Off: Non-operation</li> </ul>   |
| ENGINE START BY I-KEY    | Engine start function mode can be changed to operation with this mode <ul style="list-style-type: none"> <li>• On: Operate</li> <li>• Off: Non-operation</li> </ul>  |
| TRUNK/GLASS HATCH OPEN   | <b>NOTE:</b><br>This item is displayed, but cannot be used   |
| PANIC ALARM SET          | Panic alarm button pressing time on Intelligent Key button can be selected from the following with this mode <ul style="list-style-type: none"> <li>• MODE 1: 0.5 sec</li> <li>• MODE 2: Non-operation</li> <li>• MODE 3: 1.5 sec</li> </ul>   |
| TRUNK OPEN DELAY         | <b>NOTE:</b><br>This item is displayed, but cannot be used   |
| LO- BATT OF KEY FOB WARN | Intelligent Key low battery warning mode can be changed to operation with this mode <ul style="list-style-type: none"> <li>• On: Operate</li> <li>• Off: Non-operation</li> </ul>  |
| ANTI KEY LOCK IN FUNCTI  | Key reminder function mode can be changed to operation with this mode <ul style="list-style-type: none"> <li>• On: Operate</li> <li>• Off: Non-operation</li> </ul>  |
| HAZARD ANSWER BACK       | Hazard reminder function mode by door request switch and Intelligent Key button can be selected from the following with this mode <ul style="list-style-type: none"> <li>• Lock Only: Door lock operation only</li> <li>• Unlock Only: Door unlock operation only</li> <li>• Lock/Unlock: Lock and unlock operation</li> <li>• Off: Non-operation</li> </ul> |
| ANS BACK I-KEY LOCK      | Buzzer reminder function (lock operation) mode by door request switch can be selected from the following with this mode <ul style="list-style-type: none"> <li>• Horn Chirp: Sound horn</li> <li>• Buzzer: Sound Intelligent Key warning buzzer</li> <li>• Off: Non-operation</li> </ul>   |
| ANS BACK I-KEY UNLOCK    | Buzzer reminder function (unlock operation) mode by door request switch can be changed to operation with this mode <ul style="list-style-type: none"> <li>• On: Operate</li> <li>• Off: Non-operation</li> </ul>   |
| SHORT CRANKING OUTPUT    | Starter motor can operate during the times below <ul style="list-style-type: none"> <li>• 70 msec</li> <li>• 100 msec</li> <li>• 200 msec</li> </ul>   |
| CONFIRM KEY FOB ID       | It can be checked whether Intelligent Key ID code is registered or not in this mode  |
| AUTO LOCK SET            | Auto door lock operation time can be changed in this mode <ul style="list-style-type: none"> <li>• MODE 1: OFF</li> <li>• MODE 2: 30 sec</li> <li>• MODE 3: 1 minute</li> <li>• MODE 4: 2 minutes</li> <li>• MODE 5: 3 minutes</li> <li>• MODE 6: 4 minutes</li> <li>• MODE 7: 5 minutes</li> </ul>  |

# DIAGNOSIS SYSTEM (BCM)

## < SYSTEM DESCRIPTION >

| Monitor item           | Description   |
|------------------------|---|
| HORN WITH KEYLESS LOCK | Horn reminder function mode by Intelligent Key button can be selected from the following with this mode <ul style="list-style-type: none"> <li>• On: Operate</li> <li>• Off: Non-operation</li> </ul>                               |
| PW DOWN SET            | Unlock button pressing time on Intelligent Key button can be selected from the following with this mode <ul style="list-style-type: none"> <li>• MODE 1: 3 sec</li> <li>• MODE 2: Non-operation</li> <li>• MODE 3: 5 sec</li> </ul> |

## SELF-DIAG RESULT

Refer to [BCS-63. "DTC Index"](#).

## DATA MONITOR

### NOTE:

The following table includes information (items) inapplicable to this vehicle. For information (items) applicable to this vehicle, refer to CONSULT display items.

| Monitor Item   | Condition  |
|----------------|--|
| REQ SW -DR     | Indicates [On/Off] condition of door request switch (driver side)                          |
| REQ SW -AS     | Indicates [On/Off] condition of door request switch (passenger side)                       |
| REQ SW -BD/TR  | Indicates [On/Off] condition of back door request switch                                   |
| PUSH SW        | Indicates [On/Off] condition of push-button ignition switch                                |
| CLUTCH SW      | <b>NOTE:</b><br>This item is displayed, but cannot be monitored                            |
| BRAKE SW 1     | Indicates [On/Off]* condition of stop lamp switch power supply                             |
| BRAKE SW 2     | Indicates [On/Off] condition of stop lamp switch   |
| DETE/CANCL SW  | Indicates [On/Off] condition of P position   |
| SFT PN/N SW    | Indicates [On/Off] condition of P or N position  |
| S/L -LOCK      | <b>NOTE:</b><br>This item is displayed, but cannot be monitored                            |
| S/L -UNLOCK    | <b>NOTE:</b><br>This item is displayed, but cannot be monitored                            |
| S/L RELAY -F/B | <b>NOTE:</b><br>This item is displayed, but cannot be monitored                            |
| UNLK SEN -DR   | Indicates [On/Off] condition of driver door UNLOCK status                                  |
| PUSH SW -IPDM  | Indicates [On/Off] condition of push-button ignition switch                                |
| IGN RLY1 -F/B  | Indicates [On/Off] condition of ignition relay 1   |
| DETE SW -IPDM  | Indicates [On/Off] condition of P position   |
| SFT PN -IPDM   | Indicates [On/Off] condition of P or N position  |
| SFT P -MET     | Indicates [On/Off] condition of P position   |
| SFT N -MET     | Indicates [On/Off] condition of N position   |
| ENGINE STATE   | Indicates [Stop/Stall/Crank/Run] condition of engine states                                |
| S/L LOCK-IPDM  | <b>NOTE:</b><br>This item is displayed, but cannot be monitored                            |
| S/L UNLK-IPDM  | <b>NOTE:</b><br>This item is displayed, but cannot be monitored                            |
| S/L RELAY-REQ  | <b>NOTE:</b><br>This item is displayed, but cannot be monitored                            |
| VEH SPEED 1    | Display the vehicle speed signal received from combination meter by numerical value [km/h] |
| VEH SPEED 2    | Display the vehicle speed signal received from ABS or VDC or TCM by numerical value [km/h] |
| DOOR STAT-DR   | Indicates [LOCK/READY/UNLK] condition of unlock sensor                                     |

## DIAGNOSIS SYSTEM (BCM)

### < SYSTEM DESCRIPTION >

| Monitor Item  | Condition   |
|---------------|---|
| DOOR STAT-AS  | Indicates [LOCK/READY/UNLK] condition of passenger side door status   |
| ID OK FLAG    | Indicates [Set/Reset] condition of key ID   |
| PRMT ENG STRT | Indicates [Set/Reset] condition of engine start possibility   |
| PRMT RKE STRT | <b>NOTE:</b><br>This item is displayed, but cannot be monitored   |
| TRNK/HAT MNTR | <b>NOTE:</b><br>This item is displayed, but cannot be monitored   |
| RKE-LOCK      | Indicates [On/Off] condition of LOCK signal from Intelligent Key  |
| RKE-UNLOCK    | Indicates [On/Off] condition of UNLOCK signal from Intelligent Key  |
| RKE-TR/BD     | <b>NOTE:</b><br>This item is displayed, but cannot be monitored   |
| RKE-PANIC     | Indicates [On/Off] condition of PANIC button of Intelligent Key   |
| RKE-MODE CHG  | Indicates [On/Off] condition of MODE CHANGE signal from Intelligent Key   |
| RKE OPE COUN1 | When remote keyless entry receiver receives the signal transmitted while operating on Intelligent Key, the numerical value start changing |
| RKE OPE COUN2 | <b>NOTE:</b><br>This item is displayed, but cannot be monitored   |

\*: OFF is displayed when brake pedal is depressed while brake switch power supply is OFF.

### ACTIVE TEST

| Test item      | Description   |
|----------------|---|
| BATTERY SAVER  | This test is able to check interior room lamp operation <ul style="list-style-type: none"> <li>• On: Operate</li> <li>• Off: Non-operation</li> </ul>   |
| OUTSIDE BUZZER | This test is able to check Intelligent Key warning buzzer operation <ul style="list-style-type: none"> <li>• On: Operate</li> <li>• Off: Non-operation</li> </ul>   |
| INSIDE BUZZER  | This test is able to check warning chime in combination meter operation <ul style="list-style-type: none"> <li>• Take Out: Take away warning chime sounds when CONSULT screen is touched</li> <li>• Key: Key warning chime sounds when CONSULT screen is touched</li> <li>• Knob: OFF position warning chime sounds when CONSULT screen is touched</li> <li>• Off: Non-operation</li> </ul>   |
| INDICATOR      | This test is able to check warning lamp operation <ul style="list-style-type: none"> <li>• KEY ON: "KEY" Warning lamp illuminates when CONSULT screen is touched</li> <li>• KEY IND: "KEY" Warning lamp blinks when CONSULT screen is touched</li> <li>• Off: Non-operation</li> </ul>  |
| INT LAMP       | This test is able to check interior room lamp operation <ul style="list-style-type: none"> <li>• On: Operate</li> <li>• Off: Non-operation</li> </ul>   |
| LCD            | This test is able to check meter display information <ul style="list-style-type: none"> <li>• Engine start information displays when "BP N" on CONSULT screen is touched</li> <li>• Engine start information displays when "BP I" on CONSULT screen is touched</li> <li>• Key ID warning displays when "ID NG" on CONSULT screen is touched</li> <li>• ROTAT: This item is displayed, but cannot be used.</li> <li>• P position warning displays when "SFT P" on CONSULT screen is touched</li> <li>• INSRT: This item is displayed, but cannot be monitored</li> <li>• BATT: This item is displayed, but cannot be monitored</li> <li>• Take away through window warning displays when "NO KY" on CONSULT screen is touched</li> <li>• Take away warning display when "OUTKEY" on CONSULT screen is touched</li> <li>• OFF position warning display when "LK WN" on CONSULT screen is touched</li> </ul> |
| FLASHER        | This test is able to check hazard warning lamp operation <ul style="list-style-type: none"> <li>• LH: LH side hazard warning lamps operate</li> <li>• RH: RH side hazard warning lamps operate</li> <li>• Off: Non-operation</li> </ul>   |



# DIAGNOSIS SYSTEM (BCM)

## < SYSTEM DESCRIPTION >

| Test item        | Description   |
|------------------|---|
| P RANGE          | This test is able to check CVT shift selector power supply<br><ul style="list-style-type: none"> <li>• On: Operate</li> <li>• Off: Non-operation</li> </ul>   |
| ENGINE SW ILLUMI | This test is able to check push-button ignition switch illumination operation<br><ul style="list-style-type: none"> <li>• On: Operate</li> <li>• Off: Non-operation</li> </ul>                      |
| LOCK INDICATOR   | This test is able to check LOCK indicator (push-button ignition switch) operation<br><ul style="list-style-type: none"> <li>• On: Operate</li> <li>• Off: Non-operation</li> </ul>                  |
| ACC INDICATOR    | This test is able to check ACC indicator (push-button ignition switch) operation<br><ul style="list-style-type: none"> <li>• On: Operate</li> <li>• Off: Non-operation</li> </ul>                   |
| IGNITION ON IND  | This test is able to check ON indicator (push-button ignition switch) operation<br><ul style="list-style-type: none"> <li>• On: Operate</li> <li>• Off: Non-operation</li> </ul>                    |
| HORN             | This test is able to check horn operation<br><ul style="list-style-type: none"> <li>• On: Operate</li> <li>• Off: Non-operation</li> </ul>  |
| TRUNK/BACK DOOR  | <b>NOTE:</b><br>This item is displayed, but cannot be used  |
| POWER SLIDE DOOR | This test is able to check automatic sliding door operation<br><ul style="list-style-type: none"> <li>• RR PSD ON: Auto open/close operate</li> <li>• RL PSD ON: Auto open/close operate</li> </ul> |

## COMB SW

### COMB SW : CONSULT Function (BCM - COMB SW)

INFOID:000000011324321

#### DATA MONITOR

**NOTE:**

The following table includes information (items) inapplicable to this vehicle. For information (items) applicable to this vehicle, refer to CONSULT display items.

| Monitor item [UNIT]       | Description  |
|---------------------------|--|
| FR WIPER HI<br>[Off/On]   | Displays the status of the FR WIPER HI switch in combination switch judged by BCM with the combination switch reading function.  |
| FR WIPER LOW<br>[Off/On]  | Displays the status of the FR WIPER LOW switch in combination switch judged by BCM with the combination switch reading function. |
| FR WASHER SW<br>[Off/On]  | Displays the status of the FR WASHER switch in combination switch judged by BCM with the combination switch reading function.    |
| FR WIPER INT<br>[Off/On]  | Displays the status of the FR WIPER INT switch in combination switch judged by BCM with the combination switch reading function. |
| INT VOLUME<br>[1 - 7]     | Displays the status of wiper intermittent dial position judged by BCM with the combination switch reading function.              |
| RR WIPER ON<br>[Off/On]   | Displays the status of the RR WIPER ON switch in combination switch judged by BCM with the combination switch reading function.  |
| RR WIPER INT<br>[Off/On]  | Displays the status of the RR WIPER INT switch in combination switch judged by BCM with the combination switch reading function. |
| RR WASHER SW<br>[Off/On]  | Displays the status of the RR WASHER switch in combination switch judged by BCM with the combination switch reading function.    |
| TURN SIGNAL R<br>[Off/On] | Displays the status of the TURN RH switch in combination switch judged by BCM with the combination switch reading function.      |
| TURN SIGNAL L<br>[Off/On] | Displays the status of the TURN LH switch in combination switch judged by BCM with the combination switch reading function.      |

A  
B  
C  
D  
E  
F  
G  
H

J

K

L

BCS

N

O

P

# DIAGNOSIS SYSTEM (BCM)

## < SYSTEM DESCRIPTION >

| Monitor item [UNIT]        | Description  |
|----------------------------|--|
| TAIL LAMP SW<br>[Off/On]   | Displays the status of the TAIL LAMP switch in combination switch judged by BCM with the combination switch reading function.  |
| HI BEAM SW<br>[Off/On]     | Displays the status of the HI BEAM switch in combination switch judged by BCM with the combination switch reading function.    |
| HEAD LAMP SW 1<br>[Off/On] | Displays the status of the HEADLAMP 1 switch in combination switch judged by BCM with the combination switch reading function. |
| HEAD LAMP SW 2<br>[Off/On] | Displays the status of the HEADLAMP 2 switch in combination switch judged by BCM with the combination switch reading function. |
| PASSING SW<br>[Off/On]     | Displays the status of the PASSING switch in combination switch judged by BCM with the combination switch reading function.    |
| AUTO LIGHT SW<br>[Off/On]  | Displays the status of the AUTO LIGHT switch in combination switch judged by BCM with the combination switch reading function. |
| FR FOG SW<br>[Off/On]      | Displays the status of the FR FOG switch in combination switch judged by BCM with the combination switch reading function.     |

## BCM

### BCM : CONSULT Function (BCM - BCM)

INFOID:0000000011324322

#### WORK SUPPORT

| Item                | Description   |
|---------------------|---|
| RESET SETTING VALUE | Return a value set with Work Support of each system to a default value in factory shipment. |

## IMMU

### IMMU : CONSULT Function (BCM - IMMU)

INFOID:0000000011561488

#### WORK SUPPORT

| Service item      | Description   |
|-------------------|---|
| CONFIRM DONGLE ID | It is possible to check that dongle unit is applied to the vehicle. |

## DATA MONITOR

### NOTE:

The following table includes information (items) inapplicable to this vehicle. For information (items) applicable to this vehicle, refer to CONSULT display items.

| Monitor item   | Content   |
|----------------|---|
| CONFIRM ID ALL | Indicates [YET] at all time.<br>Switches to [DONE] when a registered Intelligent Key backside is contacted to push-button ignition switch.                |
| CONFIRM ID4    |   |
| CONFIRM ID3    |   |
| CONFIRM ID2    |   |
| CONFIRM ID1    |   |
| NOT REGISTERED | Indicates [ID OK] when key ID that is registered is received or is not yet received.<br>Indicates [ID NG] when key ID that is not registered is received. |
| TP 4           | Indicates the number of IDs that are registered.  |
| TP 3           |   |
| TP 2           |   |
| TP 1           |   |
| PUSH SW        | Indicates [ON/OFF] condition of push-button ignition switch.  |

## ACTIVE TEST

# DIAGNOSIS SYSTEM (BCM)

## < SYSTEM DESCRIPTION >

| Test item | Description   |
|-----------|---|
| THEFT IND | This test is able to check security indicator lamp operation.<br>Security indicator lamp is turned on when "ON" on CONSULT screen is touched. |

## BATTERY SAVER

### BATTERY SAVER : CONSULT Function (BCM - BATTERY SAVER)

INFOID:000000011561497

## WORK SUPPORT

| Service item   | Setting item | Setting  |
|--|--------------|--|
| ROOM LAMP TIMER SET  | MODE 1       | 30 min.  |
|  | MODE 2       | 60 min.  |
|  | MODE 3       | 15 min.  |
| <p>Sets the interior room lamp battery saver timer operating time.<br/><b>NOTE:</b><br/>The factor setting is 10 minutes. The setting cannot be returned to the factory setting, when the setting is changed once.</p> |              |  |
| BATTERY SAVER SET  | On*          | With the exterior lamp battery saver function    |
|  | Off          | Without the exterior lamp battery saver function |

\*:Factory setting

## DATA MONITOR

### NOTE:

The following table includes information (items) inapplicable to this vehicle. For information (items) applicable to this vehicle, refer to CONSULT display items.

| Monitor item<br>[Unit]    | Description   |
|---------------------------|---|
| REQ SW-DR<br>[On/Off]     | The switch status input from door request switch (driver side)    |
| REQ SW-AS<br>[On/Off]     | The switch status input from door request switch (passenger side) |
| REQ SW-RR<br>[On/Off]     | <p><b>NOTE:</b><br/>The item is indicated, but not monitored.</p> |
| REQ SW-RL<br>[On/Off]     |   |
| PUSH SW<br>[On/Off]       | The switch status input from push-button ignition switch          |
| UNLK SEN -DR<br>[On/Off]  | Driver door unlock status input from unlock sensor                |
| DOOR SW-DR<br>[On/Off]    | The switch status input from front door switch (driver side)      |
| DOOR SW-AS<br>[On/Off]    | The switch status input from front door switch (passenger side)   |
| DOOR SW-RR<br>[On/Off]    | The switch status input from sliding door switch RH               |
| DOOR SW- RL<br>[On/Off]   | The switch status input from sliding door switch LH               |
| DOOR SW- BK<br>[On/Off]   | The switch status input from back door switch                     |
| CDL LOCK SW<br>[On/Off]   | Lock switch status input from door lock and unlock switch         |
| CDL UNLOCK SW<br>[On/Off] | Unlock switch status input from door lock and unlock switch       |

# DIAGNOSIS SYSTEM (BCM)

## < SYSTEM DESCRIPTION >

| Monitor item<br>[Unit]    | Description  |
|---------------------------|--|
| TRNK/HAT MNTR<br>[On/Off] | <b>NOTE:</b><br>The item is indicated, but not monitored         |
| KEY CYL LK-SW<br>[On/Off] | Lock switch status received from door key cylinder switch        |
| KEY CYL UN-SW<br>[On/Off] | Unlock switch status received from door key cylinder switch      |
| RKE-LOCK<br>[On/Off]      | Lock signal status received from remote keyless entry receiver   |
| RKE-UNLOCK<br>[On/Off]    | Unlock signal status received from remote keyless entry receiver |

## ACTIVE TEST

| Test item     | Operation | Description  |
|---------------|-----------|--|
| BATTERY SAVER | Off       | Cuts the interior room lamp power supply to turn interior room lamps OFF.    |
|               | On        | Outputs the interior room lamp power supply to turn interior room lamps ON.* |

\*: Each lamp switch is in ON position.

## TRUNK

### TRUNK : CONSULT Function (BCM - TRUNK)

INFOID:0000000011561486

## DATA MONITOR

### NOTE:

The following table includes information (items) inapplicable to this vehicle. For information (items) applicable to this vehicle, refer to CONSULT display items.

| Monitor Item  | Contents  |
|---------------|---|
| PUSH SW       | Indicates [On/Off] condition of push switch                               |
| UNLK SEN -DR  | Indicates [On/Off] condition of unlock sensor                             |
| VEH SPEED 1   | Indicates [km/h] condition of vehicle speed signal from combination meter |
| TR/BD OPEN SW | Indicates [On/Off] condition of back door opener switch                   |
| TRNK/HAT MNTR | <b>NOTE:</b><br>This item is displayed, but cannot be monitored           |
| RKE-TR/BD     | <b>NOTE:</b><br>This item is displayed, but cannot be monitored           |

## THEFT ALM

### THEFT ALM : CONSULT Function (BCM - THEFT)

INFOID:0000000011561487

## WORK SUPPORT

| Service Item       | Description   |
|--------------------|---|
| SECURITY ALARM SET | This mode is able to confirm and change security alarm ON-OFF setting.  |
| THEFT ALM TRG      | The switch which triggered vehicle security alarm is recorded.<br>This mode is able to confirm and erase the record of vehicle security alarm.<br>The trigger data can be erased by touching "CLEAR" on CONSULT screen. |

## DATA MONITOR

### NOTE:

The following table includes information (items) inapplicable to this vehicle. For information (items) applicable to this vehicle, refer to CONSULT display items.

# DIAGNOSIS SYSTEM (BCM)

## < SYSTEM DESCRIPTION >

| Monitored Item | Description   |
|----------------|---|
| REQ SW -DR     | Indicates [ON/OFF] condition of door request switch (driver side).          |
| REQ SW -AS     | Indicates [ON/OFF] condition of door request switch (passenger side).       |
| REQ SW -RR     | <b>NOTE:</b><br>This is displayed even when it is not equipped.             |
| REQ SW -RL     | <b>NOTE:</b><br>This is displayed even when it is not equipped.             |
| REQ SW -BD/TR  | Indicates [ON/OFF] condition of back door request switch.                   |
| PUSH SW        | Indicates [ON/OFF] condition of push-button ignition switch                 |
| UNLK SEN -DR   | Indicates [ON/OFF] condition of driver door UNLOCK status.                  |
| DOOR SW-DR     | Indicates [ON/OFF] condition of front door switch (driver side).            |
| DOOR SW-AS     | Indicates [ON/OFF] condition of front door switch (passenger side).         |
| DOOR SW-RR     | Indicates [ON/OFF] condition of rear door switch RH.                        |
| DOOR SW-RL     | Indicates [ON/OFF] condition of rear door switch LH.                        |
| DOOR SW-BK     | Indicates [ON/OFF] condition of back door switch.                           |
| CDL LOCK SW    | Indicates [ON/OFF] condition of lock signal from door lock/unlock switch.   |
| CDL UNLOCK SW  | Indicates [ON/OFF] condition of unlock signal from door lock/unlock switch. |
| KEY CYL LK-SW  | Indicates [ON/OFF] condition of lock signal from door key cylinder.         |
| KEY CYL UN-SW  | Indicates [ON/OFF] condition of unlock signal from door key cylinder.       |
| TR/BD OPEN SW  | Indicates [ON/OFF] condition of back door opener switch.                    |
| TRNK/HAT MNTR  | <b>NOTE:</b><br>This is displayed even when it is not equipped.             |
| RKE-LOCK       | Indicates [ON/OFF] condition of LOCK signal from Intelligent Key.           |
| RKE-UNLOCK     | Indicates [ON/OFF] condition of UNLOCK signal from Intelligent Key.         |
| RKE-TR/BD      | <b>NOTE:</b><br>This is displayed even when it is not equipped.             |

## ACTIVE TEST

| Test Item             | Description   |
|-----------------------|---|
| THEFT IND             | This test is able to check security indicator lamp operation.<br>Security indicator lamp is turned on when "ON" on CONSULT screen is touched. |
| VEHICLE SECURITY HORN | This test is able to check horns operation.<br>Horns are activated for 0.5 seconds after "ON" on CONSULT screen is touched.                   |
| HEADLAMP(HI)          | This test is able to check headlamp operation.<br>Headlamps are activated for 0.5 seconds after "ON" on CONSULT screen is touched.            |
| FLASHER               | This test is able to check hazard warning lamp operation.<br>Hazard warning lamps are activated after "ON" on CONSULT screen is touched.      |

## RETAINED PWR

RETAINED PWR : CONSULT Function (BCM - RETAINED PWR) (Front Window Anti-pinch)

INFOID:000000011561489

## DATA MONITOR

### NOTE:

The following table includes information (items) inapplicable to this vehicle. For information (items) applicable to this vehicle, refer to CONSULT display items.

## DIAGNOSIS SYSTEM (BCM)

### < SYSTEM DESCRIPTION >

| Monitor Item | Description   |
|--------------|---|
| DOOR SW-DR   | Indicates [ON/OFF] condition of driver side door switch.    |
| DOOR SW-AS   | Indicates [ON/OFF] condition of passenger side door switch. |

### RETAINED PWR : CONSULT Function (BCM - RETAINED PWR) (Driver Side Window Anti-pinch)

INFOID:000000011561490

#### DATA MONITOR

**NOTE:**

The following table includes information (items) inapplicable to this vehicle. For information (items) applicable to this vehicle, refer to CONSULT display items.

| Monitor Item | Description   |
|--------------|---|
| DOOR SW-DR   | Indicates [ON/OFF] condition of driver side door switch.    |
| DOOR SW-AS   | Indicates [ON/OFF] condition of passenger side door switch. |

### SIGNAL BUFFER

### SIGNAL BUFFER : CONSULT Function (BCM - SIGNAL BUFFER)

INFOID:000000011324329

#### DATA MONITOR

**NOTE:**

The following table includes information (items) inapplicable to this vehicle. For information (items) applicable to this vehicle, refer to CONSULT display items.

| Monitor item [UNIT] | Description   |
|---------------------|---|
| PUSH SW<br>[Off/On] | Displays the status of the push-button ignition switch (push switch) judged by BCM. |

### ACTIVE TEST

| Test item       | Operation | Description  |
|-----------------|-----------|--|
| OIL PRESSURE SW | Off       | OFF  |
|                 | On        | BCM transmits the oil pressure switch signal to the combination meter via CAN communication, which illuminates the oil pressure warning lamp in the combination meter. |

### AIR PRESSURE MONITOR

### AIR PRESSURE MONITOR : CONSULT Function (BCM - AIR PRESSURE MONITOR)

INFOID:000000011561480

#### APPLICATION ITEM

CONSULT performs the following functions via CAN communication with BCM.

| Diagnosis mode         | Function Description  |
|------------------------|---|
| Self Diagnostic Result | Retrieve DTC from ECU and display diagnostic items.                                       |
| Data Monitor           | Monitor the input/output signal of the control unit in real time.                         |
| Active Test            | Send the drive signal from CONSULT to the actuator. The operation check can be performed. |
| Work Support           | This mode enables a technician to adjust some devices faster and more accurately.         |

#### SELF DIAGNOSTIC RESULT

Refer to [BCS-63, "DTC Index"](#).

#### DATA MONITOR MODE

**NOTE:**

# DIAGNOSIS SYSTEM (BCM)

## < SYSTEM DESCRIPTION >

The following table includes information(items)inapplicable to this vehicle. For information(items)applicable to this vehicle, refer to CONSULT display items.

| Monitor item (Unit)                  | Remarks  |
|--------------------------------------|--|
| AIR PRESS FL<br>(kPa kg/cm2 or Psi)  | Tire pressure  |
| AIR PRESS FR<br>(kPa, kg/cm2 or Psi) |  |
| AIR PRESS RR<br>(kPa, kg/cm2 or Psi) |  |
| AIR PRESS RL<br>(kPa, kg/cm2 or Psi) |  |
| ID REGST FL1<br>(Yet, Done)          | Registration ID  |
| ID REGST FR1<br>(Yet, Done)          |  |
| ID REGST RR1<br>(Yet, Done)          |  |
| ID REGST RL1<br>(Yet, Done)          |  |
| WARNING LAMP<br>(On/Off)             | Low tire pressure warning lamp                                       |
| BUZZER<br>(On/Off)                   | <b>NOTE:</b><br>This item is displayed, but cannot be use this item. |

## ACTIVE TEST MODE

### NOTE:

After completing the work below, perform an active test.

1. Check ID registration state and perform self-diagnosis.
2. Erase the self-diagnosis result history.

| Item                   | Description  |
|------------------------|--|
| WARNING LAMP           | Low tire pressure warning lamp can be turned ON arbitrarily. |
| ID REGIST WARNING      | <b>NOTE:</b><br>Displayed but not used in TPMS.              |
| RUN FLAT TIRE W/L      | <b>NOTE:</b><br>Displayed but not used in TPMS.              |
| RUN FLAT/T WARN BUZZER | <b>NOTE:</b><br>Displayed but not used in TPMS.              |
| FLASHER                | Turn signal lamps can be turned ON arbitrarily.              |
| HORN                   | This test is able to check to check that the horn sounds.    |

## WORK SUPPORT

| Item      | Description  |
|-----------|--|
| ID READ   | Registered tire pressure sensor ID can be displayed. |
| ID REGIST | Tire pressure sensor ID can be registered.           |

# BCM

< ECU DIAGNOSIS INFORMATION >

## ECU DIAGNOSIS INFORMATION

### BCM

#### Reference Value

INFOID:0000000011324331

#### VALUES ON THE DIAGNOSIS TOOL

**NOTE:**

The following table includes information (items) inapplicable to this vehicle. For information (items) applicable to this vehicle, refer to CONSULT display items.

CONSULT MONITOR ITEM

| Monitor Item   | Condition   | Value/Status                     |
|----------------|---|----------------------------------|
| FR WIPER HI    | Other than front wiper switch HI                    | Off                              |
|                | Front wiper switch HI                               | On                               |
| FR WIPER LOW   | Other than front wiper switch LO                    | Off                              |
|                | Front wiper switch LO                               | On                               |
| FR WASHER SW   | Front washer switch OFF                             | Off                              |
|                | Front washer switch ON                              | On                               |
| FR WIPER INT   | Other than front wiper switch INT                   | Off                              |
|                | Front wiper switch INT                              | On                               |
| FR WIPER STOP  | Front wiper is not in STOP position                 | Off                              |
|                | Front wiper is in STOP position                     | On                               |
| INT VOLUME     | Wiper intermittent dial is in a dial position 1 - 7 | Wiper intermittent dial position |
| RR WIPER ON    | Other than rear wiper switch ON                     | Off                              |
|                | Rear wiper switch ON                                | On                               |
| RR WIPER INT   | Other than rear wiper switch INT                    | Off                              |
|                | Rear wiper switch INT                               | On                               |
| RR WASHER SW   | Rear washer switch OFF                              | Off                              |
|                | Rear washer switch ON                               | On                               |
| RR WIPER STOP  | Rear wiper is in STOP position                      | Off                              |
|                | Rear wiper is not in STOP position                  | On                               |
| TURN SIGNAL R  | Other than turn signal switch RH                    | Off                              |
|                | Turn signal switch RH                               | On                               |
| TURN SIGNAL L  | Other than turn signal switch LH                    | Off                              |
|                | Turn signal switch LH                               | On                               |
| TAIL LAMP SW   | Other than lighting switch 1ST and 2ND              | Off                              |
|                | Lighting switch 1ST or 2ND                          | On                               |
| HI BEAM SW     | Other than lighting switch HI                       | Off                              |
|                | Lighting switch HI                                  | On                               |
| HEAD LAMP SW 1 | Other than lighting switch 2ND                      | Off                              |
|                | Lighting switch 2ND                                 | On                               |
| HEAD LAMP SW 2 | Other than lighting switch 2ND                      | Off                              |
|                | Lighting switch 2ND                                 | On                               |
| PASSING SW     | Other than lighting switch PASS                     | Off                              |
|                | Lighting switch PASS                                | On                               |
| AUTO LIGHT SW  | Other than lighting switch AUTO                     | Off                              |
|                | Lighting switch AUTO                                | On                               |



# BCM

## < ECU DIAGNOSIS INFORMATION >

| Monitor Item  | Condition   | Value/Status |     |
|---------------|---|--------------|-----|
| FR FOG SW     | Front fog lamp switch OFF   | Off          | A   |
|               | Front fog lamp switch ON  | On           |     |
| DOOR SW-DR    | Driver door closed  | Off          | B   |
|               | Driver door opened  | On           |     |
| DOOR SW-AS    | Passenger door closed   | Off          | C   |
|               | Passenger door opened   | On           |     |
| DOOR SW-RR    | Sliding door RH closed  | Off          | D   |
|               | Sliding door RH opened  | On           |     |
| DOOR SW-RL    | Sliding door LH closed  | Off          | E   |
|               | Sliding door LH opened  | On           |     |
| DOOR SW-BK    | Back door closed  | Off          | F   |
|               | Back door opened  | On           |     |
| CDL LOCK SW   | Other than power door lock switch LOCK  | Off          | G   |
|               | Power door lock switch LOCK   | On           |     |
| CDL UNLOCK SW | Other than power door lock switch UNLOCK  | Off          | H   |
|               | Power door lock switch UNLOCK   | On           |     |
| KEY CYL LK-SW | Other than driver door key cylinder LOCK position   | Off          | I   |
|               | Driver door key cylinder LOCK position  | On           |     |
| KEY CYL UN-SW | Other than driver door key cylinder UNLOCK position   | Off          | J   |
|               | Driver door key cylinder UNLOCK position  | On           |     |
| HAZARD SW     | Hazard switch is OFF  | Off          | K   |
|               | Hazard switch is ON   | On           |     |
| REAR DEF SW   | Rear window defogger switch OFF   | Off          | L   |
|               | Rear window defogger switch ON  | On           |     |
| TR/BD OPEN SW | Back door opener switch OFF   | Off          |     |
|               | While the back door opener switch is turned ON  | On           |     |
| TRNK/HAT MNTR | <b>NOTE:</b><br>The item is indicated, but not monitored.   | Off          |     |
| FAN ON SIG    | Blower fan OFF  | Off          |     |
|               | Blower fan ON   | On           |     |
| AIR COND SW   | <ul style="list-style-type: none"> <li>• Air conditioner OFF (A/C switch indicator OFF) (Automatic A/C)</li> <li>• A/C switch OFF (Manual A/C)</li> </ul> | Off          | BCS |
|               | <ul style="list-style-type: none"> <li>• Air conditioner ON (A/C switch indicator ON) (Automatic A/C)</li> <li>• A/C switch ON (Manual A/C)</li> </ul>    | On           |     |
| RKE-LOCK      | LOCK button of the key is not pressed   | Off          | N   |
|               | LOCK button of the key is pressed   | On           |     |
| RKE-UNLOCK    | UNLOCK button of the key is not pressed   | Off          | O   |
|               | UNLOCK button of the key is pressed   | On           |     |
| RKE-TR/BD     | <b>NOTE:</b><br>The item is indicated, but not monitored.   | Off          | P   |
| RKE-PANIC     | PANIC button of the key is not pressed  | Off          |     |
|               | PANIC button of the key is pressed  | On           |     |
| RKE-MODE CHG  | LOCK/UNLOCK button of the key is not pressed and held simultaneously  | Off          |     |
|               | LOCK/UNLOCK button of the key is pressed and held simultaneously  | On           |     |

# BCM

## < ECU DIAGNOSIS INFORMATION >

| Monitor Item    | Condition  | Value/Status    |
|-----------------|--|-----------------|
| SHOCK SENSOR    | Air bag signal (NORMAL) is detected.   | NOMAL           |
|                 | Air bag signal (AIR BAG OPEN) is detected.   | On              |
|                 | Air bag signal is not detected.  | Off             |
| OPTI SEN (DTCT) | Bright outside of the vehicle  | Close to 5 V    |
|                 | Dark outside of the vehicle  | Close to 0 V    |
| OPTI SEN (FILT) | Bright outside of the vehicle (Lighting switch AUTO)                               | Close to 5 V    |
|                 | Dark outside of the vehicle (Lighting switch AUTO)                                 | Close to 1.50 V |
| OPTICAL SENSOR  | <b>NOTE:</b><br>The item is indicated, but not monitored.                          | Off             |
| RAIN SENSOR     | <b>NOTE:</b><br>The item is indicated, but not monitored.                          | Off             |
| REQ SW -DR      | Driver door request switch is not pressed  | Off             |
|                 | Driver door request switch is pressed  | On              |
| REQ SW -AS      | Passenger door request switch is not pressed                                       | Off             |
|                 | Passenger door request switch is pressed   | On              |
| REQ SW -RR      | <b>NOTE:</b><br>The item is indicated, but not monitored.                          | Off             |
| REQ SW -RL      | <b>NOTE:</b><br>The item is indicated, but not monitored.                          | Off             |
| REQ SW -BD/TR   | Back door request switch is not pressed  | Off             |
|                 | Back door request switch is pressed  | On              |
| PUSH SW         | Push-button ignition switch (push switch) is not pressed                           | Off             |
|                 | Push-button ignition switch (push switch) is pressed                               | On              |
| CLUCH SW        | <b>NOTE:</b><br>The item is indicated, but not monitored.                          | Off             |
| BRAKE SW 1      | The brake pedal is not depressed   | Off             |
|                 | The brake pedal is depressed   | On              |
| BRAKE SW 2      | The brake pedal is depressed when No. 7 fuse is blown                              | Off             |
|                 | The brake pedal is not depressed when No. 7 fuse is blown, or No. 7 fuse is normal | On              |
| DETE/CANCL SW   | Selector lever in P position   | Off             |
|                 | Selector lever in any position other than P  | On              |
| SFT PN/N SW     | Selector lever in any position other than P and N                                  | Off             |
|                 | Selector lever in P or N position  | On              |
| S/L -LOCK       | <b>NOTE:</b><br>The item is indicated, but not monitored.                          | Off             |
| S/L -UNLOCK     | <b>NOTE:</b><br>The item is indicated, but not monitored.                          | Off             |
| S/L RELAY-F/B   | <b>NOTE:</b><br>The item is indicated, but not monitored.                          | Off             |
| UNLK SEN -DR    | Driver door is locked  | Off             |
|                 | Driver door is unlocked  | On              |
| PUSH SW -IPDM   | Push-button ignition switch (push-switch) is not pressed                           | Off             |
|                 | Push-button ignition switch (push-switch) is pressed                               | On              |
| IGN RLY1 -F/B   | Ignition switch in OFF or ACC position   | Off             |
|                 | Ignition switch in ON position   | On              |

# BCM

## < ECU DIAGNOSIS INFORMATION >

| Monitor Item   | Condition  | Value/Status                      |   |
|----------------|--|-----------------------------------|---|
| DETE SW -IPDM  | Selector lever in any position other than P  | Off                               | A |
|                | Selector lever in P position   | On                                |   |
| SFT PN -IPDM   | Selector lever in any position other than P and N  | Off                               | B |
|                | Selector lever in P or N position  | On                                |   |
| SFT P -MET     | Selector lever in any position other than P  | Off                               | C |
|                | Selector lever in P position   | On                                |   |
| SFT N -MET     | Selector lever in any position other than N  | Off                               | D |
|                | Selector lever in N position   | On                                |   |
| ENGINE STATE   | Engine stopped   | Stop                              | E |
|                | While the engine stalls  | Stall                             |   |
|                | At engine cranking   | Crank                             |   |
|                | Engine running   | Run                               |   |
| S/L LOCK-IPDM  | <b>NOTE:</b><br>The item is indicated, but not monitored.  | Off                               | F |
| S/L UNLK-IPDM  | <b>NOTE:</b><br>The item is indicated, but not monitored.  | Off                               | G |
| S/L RELAY-REQ  | <b>NOTE:</b><br>The item is indicated, but not monitored.  | Off                               | H |
| VEH SPEED 1    | While driving  | Equivalent to speedometer reading | I |
| VEH SPEED 2    | While driving  | Equivalent to speedometer reading | J |
| DOOR STAT-DR   | Driver door is locked  | LOCK                              |   |
|                | Wait with selective UNLOCK operation (60 seconds)  | READY                             |   |
|                | Driver door is unlocked  | UNLOCK                            |   |
| DOOR STAT-AS   | Passenger door is locked   | LOCK                              |   |
|                | Wait with selective UNLOCK operation (60 seconds)  | READY                             |   |
|                | Passenger door is unlocked   | UNLOCK                            |   |
| ID OK FLAG     | Driver side door is open after ignition switch is turned OFF (Shift position is in the P position) | Reset                             |   |
|                | Ignition switch ON   | Set                               |   |
| PRMT ENG STRT  | The engine start is prohibited   | Reset                             |   |
|                | The engine start is permitted  | Set                               |   |
| PRMT RKE STRT  | <b>NOTE:</b><br>The item is indicated, but not monitored.  | Reset                             |   |
| RKE OPE COUN1  | During the operation of the key  | Operation frequency of the key    |   |
| RKE OPE COUN2  | <b>NOTE:</b><br>The item is indicated, but not monitored.  | —                                 |   |
| CONFIRM ID ALL | The key ID that the key slot receives is not recognized by any key ID registered to BCM.           | Yet                               |   |
|                | The key ID that the key slot receives is recognized by any key ID registered to BCM.               | Done                              |   |
| CONFIRM ID4    | The key ID that the key slot receives is not recognized by the fourth key ID registered to BCM.    | Yet                               |   |
|                | The key ID that the key slot receives is recognized by the fourth key ID registered to BCM.        | Done                              |   |

BCS

# BCM

## < ECU DIAGNOSIS INFORMATION >

| Monitor Item   | Condition   | Value/Status                  |
|----------------|---|-------------------------------|
| CONFIRM ID3    | The key ID that the key slot receives is not recognized by the third key ID registered to BCM.  | Yet                           |
|                | The key ID that the key slot receives is recognized by the third key ID registered to BCM.      | Done                          |
| CONFIRM ID2    | The key ID that the key slot receives is not recognized by the second key ID registered to BCM. | Yet                           |
|                | The key ID that the key slot receives is recognized by the second key ID registered to BCM.     | Done                          |
| CONFIRM ID1    | The key ID that the key slot receives is not recognized by the first key ID registered to BCM.  | Yet                           |
|                | The key ID that the key slot receives is recognized by the first key ID registered to BCM.      | Done                          |
| NOT REGISTERED | BCM detects registered key ID, or BCM does not detect key ID.                                   | ID OK                         |
|                | BCM detects non-registration key ID.  | ID NG                         |
| TP 4           | The ID of fourth key is not registered to BCM   | Yet                           |
|                | The ID of fourth key is registered to BCM   | Done                          |
| TP 3           | The ID of third key is not registered to BCM  | Yet                           |
|                | The ID of third key is registered to BCM  | Done                          |
| TP 2           | The ID of second key is not registered to BCM   | Yet                           |
|                | The ID of second key is registered to BCM   | Done                          |
| TP 1           | The ID of first key is not registered to BCM  | Yet                           |
|                | The ID of first key is registered to BCM  | Done                          |
| AIR PRESS FL   | Ignition switch ON (Only when the signal from the transmitter is received)                      | Air pressure of front LH tire |
| AIR PRESS FR   | Ignition switch ON (Only when the signal from the transmitter is received)                      | Air pressure of front RH tire |
| AIR PRESS RR   | Ignition switch ON (Only when the signal from the transmitter is received)                      | Air pressure of rear RH tire  |
| AIR PRESS RL   | Ignition switch ON (Only when the signal from the transmitter is received)                      | Air pressure of rear LH tire  |
| ID REGST FL1   | ID of front LH tire transmitter is registered   | Done                          |
|                | ID of front LH tire transmitter is not registered   | Yet                           |
| ID REGST FR1   | ID of front RH tire transmitter is registered   | Done                          |
|                | ID of front RH tire transmitter is not registered   | Yet                           |
| ID REGST RR1   | ID of rear RH tire transmitter is registered  | Done                          |
|                | ID of rear RH tire transmitter is not registered  | Yet                           |
| ID REGST RL1   | ID of rear LH tire transmitter is registered  | Done                          |
|                | ID of rear LH tire transmitter is not registered  | Yet                           |
| WARNING LAMP   | Tire pressure indicator OFF   | Off                           |
|                | Tire pressure indicator ON  | On                            |
| BUZZER         | Tire pressure warning alarm is not sounding   | Off                           |
|                | Tire pressure warning alarm is sounding   | On                            |

# BCM

< ECU DIAGNOSIS INFORMATION >

## TERMINAL LAYOUT

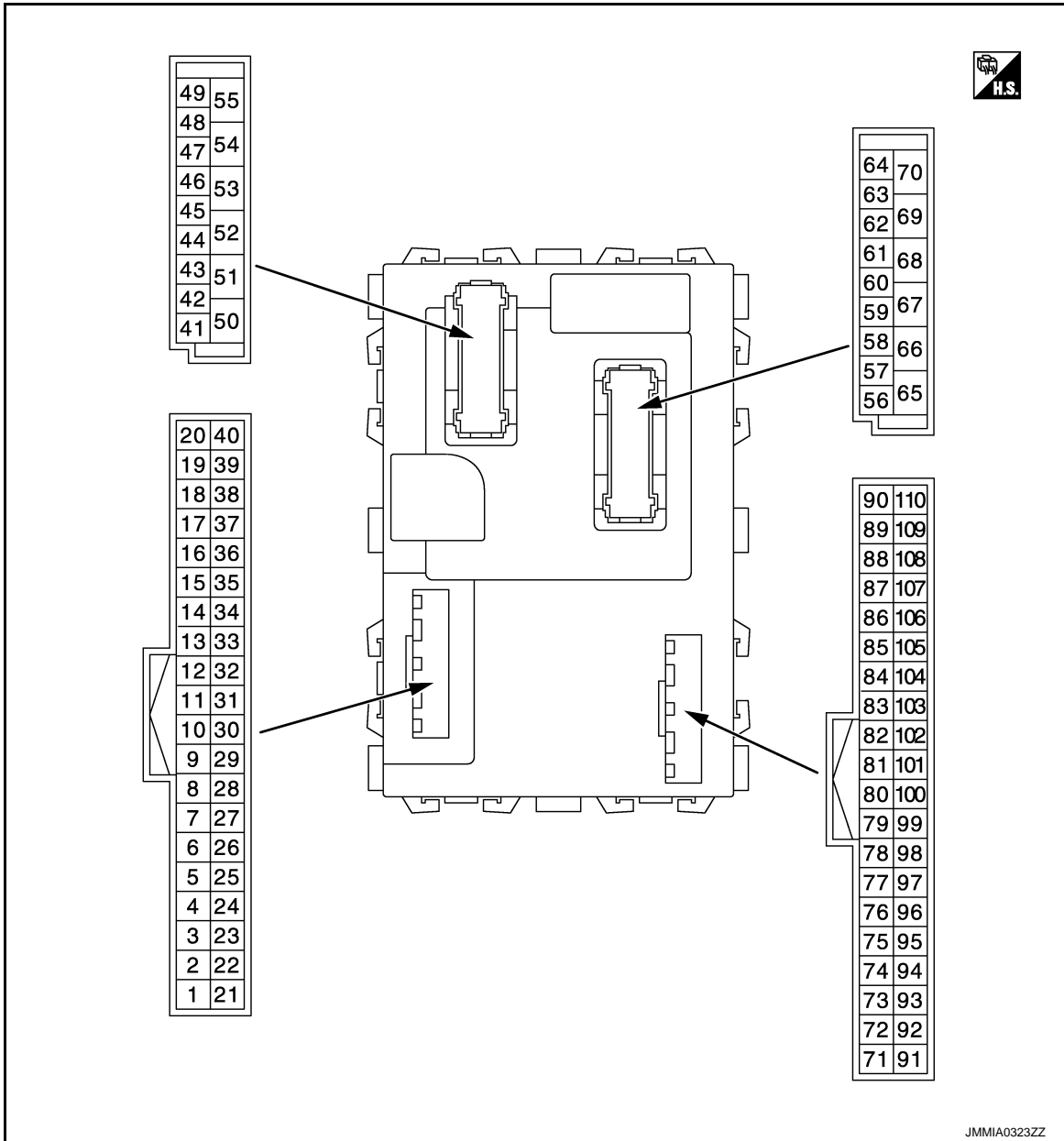

## PHYSICAL VALUES

| Terminal No.<br>(Wire color) |        | Description                        |                  | Condition            | Value<br>(Approx.)           |
|------------------------------|--------|------------------------------------|------------------|----------------------|------------------------------|
| +                            | -      | Signal name                        | Input/<br>Output |                      |                              |
| 1<br>(W)                     | Ground | Rear window defogger relay control | Input            | Rear window defogger | OFF 9 - 16 V<br>ON 0 - 0.6 V |

A  
B  
C  
D  
E  
F  
G  
H  
I  
J  
K  
L

BCS

N  
O  
P

# BCM

## < ECU DIAGNOSIS INFORMATION >

| Terminal No.<br>(Wire color) |        | Description                   |                  | Condition   | Value<br>(Approx.)       |   |
|------------------------------|--------|-------------------------------|------------------|---|--------------------------|---|
| +                            | -      | Signal name                   | Input/<br>Output |   |                          |   |
| 2<br>(R)                     | Ground | Combination switch<br>INPUT 5 | Input            | Combination<br>switch<br>(Wiper volume<br>dial 4) | All switches OFF         | 0 V   |
|                              |        |                               |                  |   | Turn signal switch RH    | <p style="text-align: right; font-size: small;">PKIB4958J</p> |
|                              |        |                               |                  |   | Lighting switch HI       |   |
|                              |        |                               |                  |   | Lighting switch 1ST      |   |
|                              |        |                               |                  |   | Lighting switch 2ND      |   |
| 3<br>(G)                     | Ground | Combination switch<br>INPUT 4 | Input            | Combination<br>switch<br>(Wiper volume<br>dial 4) | All switches OFF         | 0 V   |
|                              |        |                               |                  |   | Turn signal switch LH    | <p style="text-align: right; font-size: small;">PKIB4958J</p> |
|                              |        |                               |                  |   | Lighting switch PASS     |   |
|                              |        |                               |                  |   | Lighting switch 2ND      |   |
|                              |        |                               |                  |   | Front fog lamp switch ON |   |
| 4<br>(BE)                    | Ground | Combination switch<br>INPUT 3 | Input            | Combination<br>switch<br>(Wiper volume<br>dial 4) | All switches OFF         | 0 V   |
|                              |        |                               |                  |   | Front wiper switch LO    | <p style="text-align: right; font-size: small;">PKIB4958J</p> |
|                              |        |                               |                  |   | Front wiper switch MIST  |   |
|                              |        |                               |                  |   | Front wiper switch INT   |   |
|                              |        |                               |                  |   | Lighting switch AUTO     |   |

# BCM

## < ECU DIAGNOSIS INFORMATION >

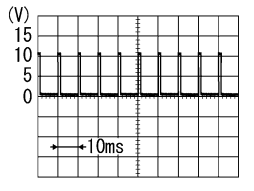
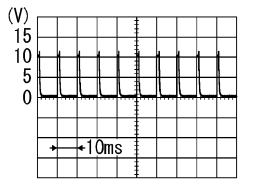
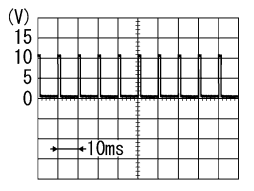
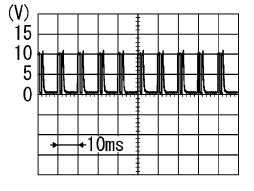
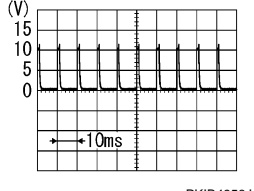
| Terminal No.<br>(Wire color) |        | Description                   |                  | Condition             | Value<br>(Approx.)  |  |  |  |  |   |
|------------------------------|--------|-------------------------------|------------------|-----------------------|---|--|--|--|--|---|
| +                            | -      | Signal name                   | Input/<br>Output |                       |   |  |  |  |  |   |
| 5<br>(G)                     | Ground | Combination switch<br>INPUT 2 | Input            | Combination<br>switch | All switches OFF<br>(Wiper volume dial 4)   | 0 V  |  |  |  |   |
|                              |        |                               |                  |                       | Front washer switch ON<br>(Wiper volume dial 4)   |   |  |  |  |   |
|                              |        |                               |                  |                       | Rear washer switch ON<br>(Wiper volume dial 4)  |  |  |  |  |   |
|                              |        |                               |                  |                       | Any of the condition below<br>with all switches OFF <ul style="list-style-type: none"> <li>• Wiper volume dial 1</li> <li>• Wiper volume dial 5</li> <li>• Wiper volume dial 6</li> </ul> |  |  |  |  |   |
|                              |        |                               |                  |                       | Rear wiper switch ON<br>(Wiper volume dial 4)   |   |  |  |  |   |
| 6<br>(W)                     | Ground | Combination switch<br>INPUT 1 | Input            | Combination<br>switch | All switches OFF<br>(Wiper volume dial 4)   | 0 V  |  |  |  |   |
|                              |        |                               |                  |                       | Front wiper switch HI<br>(Wiper volume dial 4)  |  |  |  |  |   |
|                              |        |                               |                  |                       | Rear wiper switch INT<br>(Wiper volume dial 4)  |  |  |  |  |   |
|                              |        |                               |                  |                       | Wiper volume dial 3<br>(All switches OFF)   |  |  |  |  |   |
|                              |        |                               |                  |                       |   |  |  |  | Any of the condition below<br>with all switches OFF <ul style="list-style-type: none"> <li>• Wiper volume dial 1</li> <li>• Wiper volume dial 2</li> </ul> |  |
|                              |        |                               |                  |                       |   |  |  |  | Any of the condition below<br>with all switches OFF <ul style="list-style-type: none"> <li>• Wiper volume dial 6</li> <li>• Wiper volume dial 7</li> </ul> |  |

A  
B  
C  
D  
E  
F  
G  
H  
I  
J  
K  
L  
N  
O  
P

BCS

# BCM

## < ECU DIAGNOSIS INFORMATION >

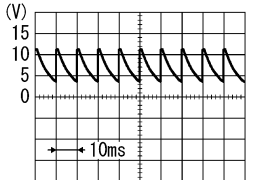
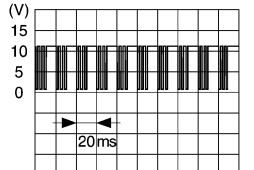
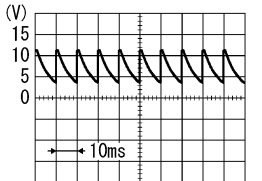
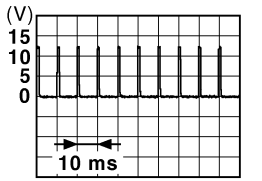
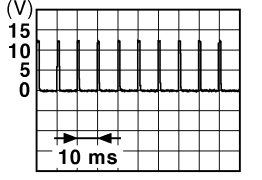
| Terminal No.<br>(Wire color) |        | Description   |                  | Condition                          | Value<br>(Approx.)   |
|------------------------------|--------|---|------------------|------------------------------------|--|
| +                            | -      | Signal name   | Input/<br>Output |                                    |  |
| 7*1<br>(W)                   | Ground | Door key cylinder<br>switch UNLOCK  | Input            | Door key cylinder switch           | NEUTRAL position<br><br>7.0 - 8.0 V   |
|                              |        |   |                  | UNLOCK position                    | 0 V  |
| 8<br>(GR)*1<br>(Y)*2         | Ground | Power window<br>switch communica-<br>tion (with automatic<br>sliding door system) | Input/<br>Output | Ignition switch ON                 | <br>9.0 - 10 V                        |
|                              |        | Door key cylinder<br>switch LOCK (with-<br>out automatic sliding<br>door system)  | Input            | Door key cylinder<br>switch        | NEUTRAL position<br><br>7.0 - 8.0 V  |
| 9<br>(GR)                    | Ground | Stop lamp switch 1  | Input            | Stop lamp<br>switch                | OFF (Brake pedal is not<br>depressed)<br>0 V   |
|                              |        |   |                  | ON (Brake pedal is de-<br>pressed) | 9 - 16 V   |
| 12*1<br>(GR)                 | Ground | Door lock and unlock<br>switch LOCK   | Input            | Door lock and<br>unlock switch     | NEUTRAL position<br><br>1.0 - 1.5 V |
|                              |        |   |                  | LOCK position                      | 0 V  |
| 13*1<br>(BR)                 | Ground | Door lock and unlock<br>switch UNLOCK   | Input            | Door lock and<br>unlock switch     | NEUTRAL position<br><br>1.0 - 1.5 V |
|                              |        |   |                  | UNLOCK position                    | 0 V  |



# BCM

## < ECU DIAGNOSIS INFORMATION >

| Terminal No.<br>(Wire color) |        | Description                     |                  | Condition   | Value<br>(Approx.)  |
|------------------------------|--------|---------------------------------|------------------|---|---|
| +                            | -      | Signal name                     | Input/<br>Output |   |   |
| 14<br>(L)                    | Ground | Optical sensor                  | Input            | Ignition switch ON  | When bright outside of the vehicle<br>Close to 5 V  |
|                              |        |                                 |                  | When dark outside of the vehicle<br>Close to 0 V  |   |
| 15<br>(W)                    | Ground | Rear window defogger switch     | Input            | Rear window defogger switch   | Not pressed<br><br>1.0 - 1.5 V  |
|                              |        |                                 |                  | Pressed<br>0 V  |   |
| 16*3<br>(Y)                  | Ground | Dimmer signal                   | Output           | Ignition switch ON  | Either of the following conditions<br>• Lighting switch OFF<br>• The area around the vehicle is bright (Shine a light on the optical sensor)<br>0 V |
|                              |        |                                 |                  | The area around the vehicle is dark (Block the light from the optical sensor)<br>7.5 - 16 V |   |
| 17<br>(O)                    | Ground | Sensor power supply             | Output           | Ignition switch OFF, ACC<br>0 V   |   |
|                              |        |                                 |                  | ON<br>4.65 - 5.5 V  |   |
| 18<br>(R)                    | Ground | Receiver and sensor ground      | Input            | Ignition switch ON<br>0 V   |   |
| 21<br>(GR)                   | Ground | NATS antenna amp.               | Input/<br>Output | Intelligent Key: Intelligent Key battery is removed   | Brake pedal: Depressed<br><b>NOTE:</b> Waveform varies each time when brake pedal is depressed<br><br>9 - 16 V                                      |
|                              |        |                                 |                  | Brake pedal: Not depressed<br>9 - 16 V  |   |
| 23<br>(W)                    | Ground | Security indicator lamp control | Output           | Security indicator lamp ON  | 0 - 0.5 V   |
|                              |        |                                 |                  | Security indicator lamp OFF   | Blinking (Ignition switch OFF)<br><br>12.0 V  |
| 24*4<br>(B)                  | Ground | Dongle link                     | Input/<br>Output | Ignition switch OFF<br>5 V  |   |

A  
B  
C  
D  
E  
F  
G  
H  
I  
J  
K  
L  
N  
O  
P

BCS

# BCM

## < ECU DIAGNOSIS INFORMATION >

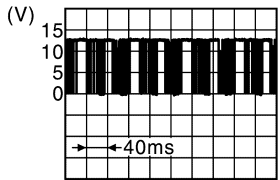
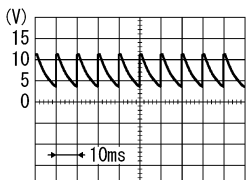
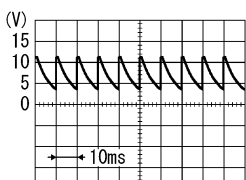
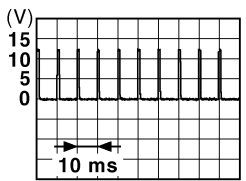
| Terminal No.<br>(Wire color) |        | Description                               |                  | Condition   | Value<br>(Approx.)   |   |
|------------------------------|--------|---|------------------|---|--|---|
| +                            | -      | Signal name                               | Input/<br>Output |   |  |   |
| 25<br>(P)                    | Ground | NATS antenna amp.                         | Input/<br>Output | During waiting  | Brake pedal: Depressed<br><b>NOTE:</b><br>Waveform varies each time when brake pedal is depressed<br><br><small>JMKIA6233JP</small> |   |
|                              |        |   |                  | Brake pedal: Not depressed                              | 9 - 16 V   |   |
| 27<br>(O)                    | Ground | A/C ON (Automatic air conditioner)        | Input            | A/C   | OFF (A/C switch indicator: OFF)<br><br><small>PKIB4960J</small>   |   |
|                              |        |   |                  | ON (A/C switch indicator: ON)                           | 0 V  |   |
|                              |        | A/C ON (Manual c air conditioner)         | Input            | Ignition switch ON and blower fan switch other than OFF | A/C switch OFF   | 12 V  |
|                              |        |   |                  | A/C switch ON   | 0 V  |   |
| 28<br>(BR)                   | Ground | Blower fan ON (Automatic air conditioner) | Input            | Fan switch  | OFF  | 12 V  |
|                              |        |   |                  | ON  | 0 V  |   |
|                              |        | Blower fan ON (Manual air conditioner)    | Input            | Fan switch  | OFF  | <br><small>PKIB4960J</small> |
|                              |        |   |                  |   | Other than OFF   | 0 V   |
| 29<br>(P)                    | Ground | Hazard switch                             | Input            | Hazard switch   | OFF  | 9 - 16 V  |
|                              |        |   |                  | ON  | 0 - 1.5 V  |   |
| 30<br>(L)                    | Ground | Back door opener switch                   | Input            | Back door opener switch                                 | Pressed  | 0 V   |
|                              |        |   |                  | Not pressed   | <br><small>JPMIA0012GB</small>  |   |

# BCM

## < ECU DIAGNOSIS INFORMATION >

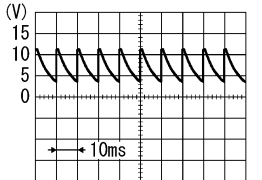
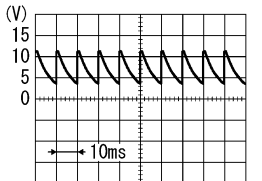
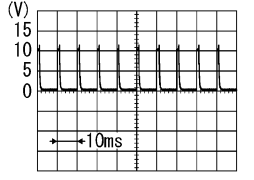
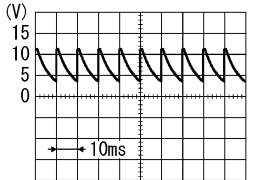
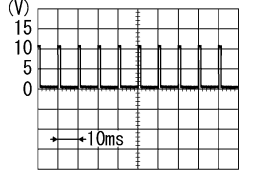
| Terminal No.<br>(Wire color) |   | Description  |                  | Condition             | Value<br>(Approx.)   |  |
|------------------------------|---|--|------------------|-----------------------|--|--|
|                              |   | Signal name  | Input/<br>Output |                       |  |  |
| +                            | -   |  |                  |                       |  |  |
| 31<br>(G)                    | Ground  | Front door lock as-<br>sembly driver side<br>(Unlock sensor) | Input            | Driver door           |  <p style="text-align: right; font-size: small;">PKIB4960J</p> <p style="text-align: center;">7.0 - 8.0 V</p>                         |  |
|                              |   |  |                  |                       | UNLOCK status (Unlock<br>sensor switch ON)   | 0 V  |
| 32<br>(R)                    | Ground  | Combination switch<br>OUTPUT 5                               | Output           | Combination<br>switch |  <p style="text-align: right; font-size: small;">PKIB4960J</p> <p style="text-align: center;">7.0 - 8.0 V</p>                         |  |
|                              |   |  |                  |                       | Front fog lamp switch ON<br>(Wiper volume dial 4)  |  <p style="text-align: right; font-size: small;">PKIB4956J</p> <p style="text-align: center;">1.0 V</p>  |
|                              |   |  |                  |                       | Rear wiper switch ON<br>(Wiper volume dial 4)  |  |
|                              |   |  |                  |                       | Any of the condition below<br>with all switches OFF <ul style="list-style-type: none"> <li>• Wiper volume dial 1</li> <li>• Wiper volume dial 2</li> <li>• Wiper volume dial 6</li> <li>• Wiper volume dial 7</li> </ul> |  |
| 33<br>(W)                    | Ground  | Combination switch<br>OUTPUT 4                               | Output           | Combination<br>switch |  <p style="text-align: right; font-size: small;">PKIB4960J</p> <p style="text-align: center;">7.0 - 8.0 V</p>                       |  |
|                              |   |  |                  |                       | Lighting switch 1ST<br>(Wiper volume dial 4)   |  <p style="text-align: right; font-size: small;">PKIB4958J</p> <p style="text-align: center;">1.2 V</p> |
|                              |   |  |                  |                       | Lighting switch AUTO<br>(Wiper volume dial 4)  |  |
|                              |   |  |                  |                       | Rear wiper switch INT<br>(Wiper volume dial 4)   |  |
|                              | Any of the condition below<br>with all switches OFF <ul style="list-style-type: none"> <li>• Wiper volume dial 1</li> <li>• Wiper volume dial 5</li> <li>• Wiper volume dial 6</li> </ul> |  |                  |                       |  |  |

A  
B  
C  
D  
E  
F  
G  
H  
I  
J  
K  
L  
N  
O  
P



# BCM

## < ECU DIAGNOSIS INFORMATION >

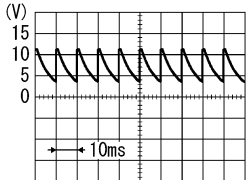
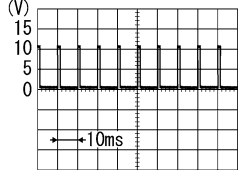
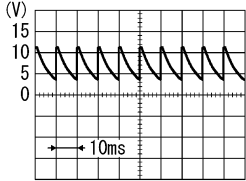
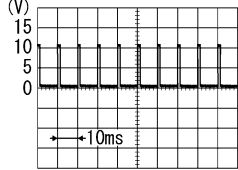
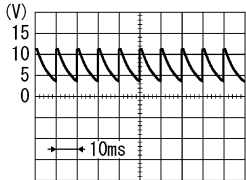
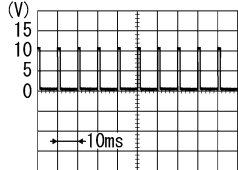
| Terminal No.<br>(Wire color)  |        | Description                    |                  | Condition   | Value<br>(Approx.)                             |  |
|---|--------|--------------------------------|------------------|---|--|--|
| +   | -      | Signal name                    | Input/<br>Output |   |  |  |
| 34<br>(P)   | Ground | Combination switch<br>OUTPUT 3 | Output           | Combination<br>switch                             | All switches OFF<br>(Wiper volume dial 4)      |  <p style="text-align: right;">PKIB4960J</p> <p style="text-align: center;">7.0 - 8.0 V</p>   |
|   |        |                                |                  |   | Lighting switch 2ND<br>(Wiper volume dial 4)   |  <p style="text-align: right;">PKIB4958J</p> <p style="text-align: center;">1.2 V</p>         |
|   |        |                                |                  |   | Lighting switch HI<br>(Wiper volume dial 4)    |  |
|   |        |                                |                  |   | Rear washer switch ON<br>(Wiper volume dial 4) |  |
| Any of the condition below<br>with all switches OFF   |        |                                |                  |   |  |  |
| <ul style="list-style-type: none"> <li>• Wiper volume dial 1</li> <li>• Wiper volume dial 2</li> <li>• Wiper volume dial 3</li> </ul> |        |                                |                  |   |  |  |
| 35<br>(GR)  | Ground | Combination switch<br>OUTPUT 2 | Output           | Combination<br>switch<br>(Wiper volume<br>dial 4) | All switches OFF                               |  <p style="text-align: right;">PKIB4960J</p> <p style="text-align: center;">7.0 - 8.0 V</p>  |
|   |        |                                |                  |   | Lighting switch 2ND                            |  <p style="text-align: right;">PKIB4958J</p> <p style="text-align: center;">1.2 V</p>       |
|   |        |                                |                  |   | Lighting switch PASS                           |  |
|   |        |                                |                  |   | Front wiper switch INT                         |  |
| Front wiper switch HI   |        |                                |                  |   |  |  |
| 36<br>(R)   | Ground | Combination switch<br>OUTPUT 1 | Output           | Combination<br>switch<br>(Wiper volume<br>dial 4) | All switches OFF                               |  <p style="text-align: right;">PKIB4960J</p> <p style="text-align: center;">7.0 - 8.0 V</p> |
|   |        |                                |                  |   | Turn signal switch RH                          |  <p style="text-align: right;">PKIB4958J</p> <p style="text-align: center;">1.2 V</p>       |
|   |        |                                |                  |   | Turn signal switch LH                          |  |
|   |        |                                |                  |   | Front wiper switch LO                          |  |
| Front wiper switch MIST   |        |                                |                  |   |  |  |
| Front washer switch ON  |        |                                |                  |   |  |  |

# BCM

## < ECU DIAGNOSIS INFORMATION >

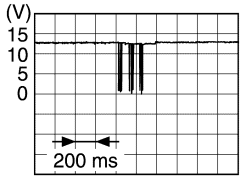
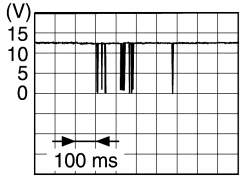
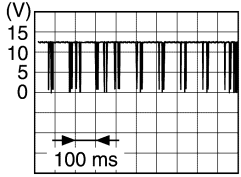
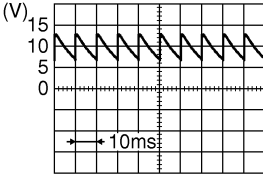
| Terminal No.<br>(Wire color) |        | Description              |                  | Condition   | Value<br>(Approx.)                                  |   |                  |   |   |
|------------------------------|--------|--------------------------|------------------|---|---|---|------------------|---|---|
| +                            | -      | Signal name              | Input/<br>Output |   |   |   |                  |   |   |
| 37<br>(G)                    | Ground | Detention switch         | Input            | Selector lever  | P position (Release selector button)                | 0 – 1.5 V   |                  |   |   |
|                              |        |                          |                  |   | P position (Push selector button)                   | 6 – 16 V  |                  |   |   |
|                              |        |                          |                  |   | Any position other than P                           |   |                  |   |   |
| 38<br>(BE)                   | Ground | Receiver communication   | Input/<br>Output | Ignition switch<br>OFF (Remote<br>keyless entry<br>communication) | Waiting   | 12 V  |                  |   |   |
|                              |        |                          |                  |   | When operating either<br>button on Intelligent Key  |    | JMMIA0572GB      |   |   |
|                              |        |                          |                  | Ignition switch<br>ON (TPMS<br>communication)                     | Waiting   |    | JMMIA0573GB      |   |   |
|                              |        |                          |                  |   | When receiving signal<br>from tire pressure sensor  |  | JMMIA0574GB      |   |   |
|                              |        |                          |                  | 39<br>(L)   | Ground  | CAN-H   | Input/<br>Output | — | — |
|                              |        |                          |                  | 40<br>(P)   | Ground  | CAN-L   | Input/<br>Output | — | — |
| 43<br>(P)                    | Ground | Back door switch         | Input            | Back door<br>switch   | OFF<br>(When back door closed)                      |  | JPMIA0593GB      |   |   |
|                              |        |                          |                  |   | ON<br>(When back door opened)                       | 9.0 - 10.0 V  | 0 V              |   |   |
| 44<br>(GR)                   | Ground | Rear wiper stop position | Input            | Ignition switch<br>ON   | Rear wiper stop position                            | 12 V  |                  |   |   |
|                              |        |                          |                  |   | Any position other than<br>rear wiper stop position | 0 V   |                  |   |   |

A  
B  
C  
D  
E  
F  
G  
H  
I  
J  
K  
L  
N  
O  
P

BCS

# BCM

## < ECU DIAGNOSIS INFORMATION >

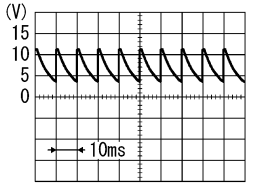
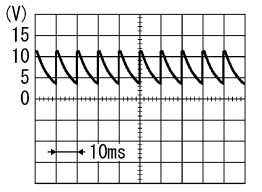
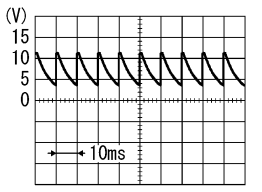
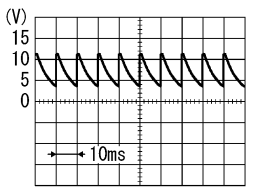
| Terminal No.<br>(Wire color) |        | Description   |                  | Condition                |   | Value<br>(Approx.)   |
|------------------------------|--------|---|------------------|--------------------------|---|--|
| +                            | -      | Signal name   | Input/<br>Output |                          |   |  |
| 45<br>(W)                    | Ground | Passenger door switch   | Input            | Passenger door switch    | OFF (When passenger door closed)              | <br>7.0 - 8.0 V   |
|                              |        |   |                  |                          | ON (When passenger door opened)               | 0 V  |
| 46<br>(R)                    | Ground | Sliding door RH switch  | Input            | Sliding door RH switch   | OFF (When sliding door RH closed)             | <br>7.0 - 8.0 V   |
|                              |        |   |                  |                          | ON (When sliding door RH opened)              | 0 V  |
| 47<br>(G)                    | Ground | Driver door switch  | Input            | Driver door switch       | OFF (When driver door closed)                 | <br>7.0 - 8.0 V  |
|                              |        |   |                  |                          | ON (When driver door opened)                  | 0 V  |
| 48<br>(BE)                   | Ground | Sliding door LH switch  | Input            | Sliding door LH switch   | OFF (When sliding door LH closed)             | <br>7.0 - 8.0 V |
|                              |        |   |                  |                          | ON (When sliding door LH opened)              | 0 V  |
| 49<br>(B)                    | Ground | Luggage room lamp control                                       | Output           | Luggage room lamp        | OFF   | 9 - 16 V   |
|                              |        |   |                  |                          | ON  | 0 - 1.0 V  |
| 50*2<br>(V)                  | Ground | Selective unlock relay control (Sliding door LH UNLOCK control) | Input            | Sliding door LH          | UNLOCK (Actuator is activated)                | 0 - 0.6 V  |
|                              |        |   |                  |                          | Other than UNLOCK (Actuator is not activated) | 9 - 16 V   |
| 51<br>(G)                    | Ground | Back door request switch  | Input            | Back door request switch | ON (Pressed)                                  | 0 - 1.5 V  |
|                              |        |   |                  |                          | OFF (Not pressed)                             | 9 - 16 V   |

# BCM

## < ECU DIAGNOSIS INFORMATION >

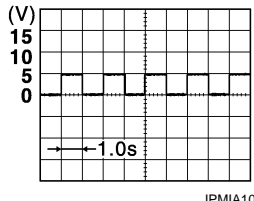
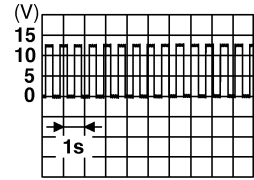
| Terminal No.<br>(Wire color) |        | Description   |                  | Condition   |   | Value<br>(Approx.)   |
|------------------------------|--------|---|------------------|---|---|--|
| +                            | -      | Signal name   | Input/<br>Output |   |   |  |
| 53*5<br>(BR)                 | Ground | Back door open request                                      | Output           | Back door opener switch   | OFF (Actuator is not activated)               | 9 - 16 V   |
|                              |        |   |                  |   | ON (Actuator is activated)                    | 0 - 1.5 V<br>(Approx. 500m seconds)  |
| 54<br>(R)                    | Ground | Rear wiper  | Output           | Rear wiper  | OFF (Stopped)                                 | 0 V  |
|                              |        |   |                  |   | ON (Activated)                                | 9 - 16 V   |
| 55<br>(G)                    | Ground | Sliding door RH UNLOCK (with automatic sliding door system) | Output           | Sliding door RH   | UNLOCK (Actuator is activated)                | 9 - 16 V   |
|                              |        |   |                  |   | Other than UNLOCK (Actuator is not activated) | 0 V  |
|                              |        | Sliding door UNLOCK (without automatic sliding door system) |                  | Sliding door  | UNLOCK (Actuator is activated)                | 9 - 16 V   |
|                              |        |   |                  |   | Other than UNLOCK (Actuator is not activated) | 0 V  |
| 56<br>(P)                    | Ground | Interior room lamp power supply                             | Output           | Interior room lamp battery saver is activated.<br>(Cuts the interior room lamp power supply)        | 0 V   |  |
|                              |        |   |                  | Interior room lamp battery saver is not activated.<br>(Outputs the interior room lamp power supply) | 9 - 16 V                                      |  |
| 57<br>(Y)                    | Ground | Battery power supply  | Input            | Ignition switch OFF   |   | 9 - 16 V   |
| 58<br>(O)                    | Ground | Air bag signal  | Input            | Ignition switch   | OFF   | 5 V  |
|                              |        |   |                  |   | ON  | <br>2.5 V   |
| 59<br>(SB)                   | Ground | Passenger door UNLOCK                                       | Output           | Passenger door  | UNLOCK (Actuator is activated)                | 9 - 16 V   |
|                              |        |   |                  |   | Other than UNLOCK (Actuator is not activated) | 0 V  |
| 60<br>(V)                    | Ground | Turn signal LH  | Output           | Ignition switch ON  | Turn signal switch OFF                        | 0 V  |
|                              |        |   |                  |   | Turn signal switch LH                         | <br>6.5 V<br>(Turn signal lamp turn on: 9 - 16 V) |

A  
B  
C  
D  
E  
F  
G  
H  
I  
J  
K  
L  
N  
O  
P

B C S

# BCM

## < ECU DIAGNOSIS INFORMATION >

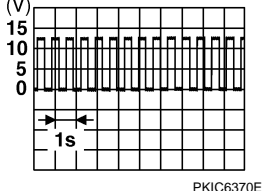
| Terminal No.<br>(Wire color) |        | Description                               |                  | Condition  | Value<br>(Approx.)   |
|------------------------------|--------|---|------------------|--|--|
| +                            | -      | Signal name                               | Input/<br>Output |  |  |
| 61<br>(G)                    | Ground | Turn signal RH                            | Output           | Ignition switch<br>ON  | Turn signal switch OFF<br>0 V  |
|                              |        |   |                  | Turn signal switch RH  | <br>6.5 V<br>(Turn signal lamp turn on: 9 - 16 V) |
| 62<br>(W)                    | Ground | Step lamp                                 | Output           | Step lamp  | ON<br>0 - 1.0 V  |
|                              |        |   |                  | OFF<br>9 - 16 V  |  |
| 63<br>(R)                    | Ground | Interior room lamp control                | Output           | Interior room lamp   | OFF<br>9 - 16 V  |
|                              |        |   |                  | ON<br>0 - 1.0 V  |  |
| 64<br>(W)                    | Ground | Cranking request                          | input            | Ignition switch<br>ON  | Engine stopped (Selector lever is in P position)<br>0 - 1.0 V  |
|                              |        |   |                  | Engine stopped (Selector lever is not in P position)<br>9 - 16 V |  |
|                              |        |   |                  | Engine running<br>9 - 16 V                                       |  |
| 65<br>(V)                    | Ground | All doors LOCK                            | Output           | All doors  | LOCK (Actuator is activated)<br>9 - 16 V   |
|                              |        |   |                  | Other than LOCK (Actuator is not activated)<br>0 V               |  |
| 66<br>(G)                    | Ground | Driver door UN-LOCK                       | Output           | Driver door, fuel lid  | UNLOCK (Actuator is activated)<br>9 - 16 V   |
|                              |        |   |                  | Other than UNLOCK (Actuator is not activated)<br>0 V             |  |
| 67<br>(B)                    | Ground | Ground                                    | Output           | Ignition switch ON   | 0 V  |
| 68<br>(L)                    | Ground | P/W power supply (IGN)                    | Output           | Ignition switch OFF  | 0 V  |
|                              |        |   |                  | Ignition switch ON   | 9 - 16 V   |
| 69<br>(P)                    | Ground | P/W power supply (BAT)                    | Output           | Ignition switch OFF  | 9 - 16 V   |
| 70<br>(L)                    | Ground | Battery power supply                      | Input            | Ignition switch OFF  | 9 - 16 V   |
| 73<br>(G)                    | Ground | ON indicator lamp                         | Output           | Ignition switch  | OFF (LOCK indicator is not illuminated)<br>9 - 16 V  |
|                              |        |   |                  | ON<br>0 - 1.5 V  |  |
| 75<br>(G)                    | Ground | Driver door request switch                | Input            | Driver door request switch                                       | ON (Pressed)<br>0 - 1.5 V  |
|                              |        |   |                  | OFF (Not pressed)<br>9 - 16 V                                    |  |
| 76<br>(V)                    | Ground | Push-button ignition switch (push switch) | Input            | Push-button ignition switch (push switch)                        | Pressed<br>0 - 1.5 V   |
|                              |        |   |                  | Not pressed<br>9 - 16 V  |  |



# BCM

## < ECU DIAGNOSIS INFORMATION >

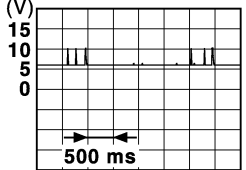
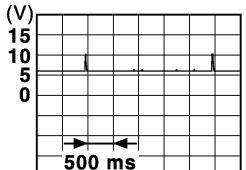
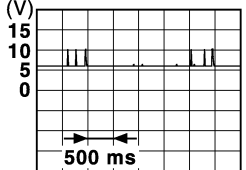
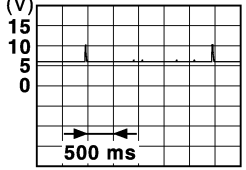
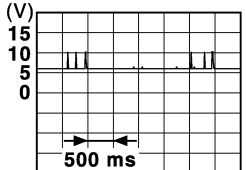
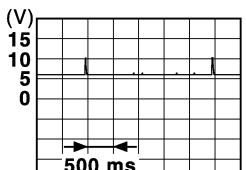
| Terminal No.<br>(Wire color) |        | Description                   |                  | Condition  | Value<br>(Approx.)   |
|------------------------------|--------|-------------------------------|------------------|--|--|
|                              |        | Signal name                   | Input/<br>Output |  |  |
| +                            | -      |                               |                  |  |  |
| 78<br>(B)                    | Ground | Driver door antenna<br>(+)    | Output           | When the driver door request switch is operated with ignition switch ON    | <p>When Intelligent Key is not in the antenna detection area<br/>(The distance between Intelligent Key and antenna: Approx. 2 m)</p>  <p style="text-align: right; font-size: small;">JMKIA5954GB</p>   |
|                              |        |                               |                  | When the driver door request switch is operated with ignition switch ON    | <p>When Intelligent Key is in the antenna detection area<br/>(The distance between Intelligent Key and antenna: 80 cm or less)</p>  <p style="text-align: right; font-size: small;">JMKIA5955GB</p>     |
| 79<br>(W)                    | Ground | Driver door antenna<br>(-)    | Output           | When the driver door request switch is operated with ignition switch ON    | <p>When Intelligent Key is not in the antenna detection area<br/>(The distance between Intelligent Key and antenna: Approx. 2 m)</p>  <p style="text-align: right; font-size: small;">JMKIA5954GB</p>  |
|                              |        |                               |                  | When the driver door request switch is operated with ignition switch ON    | <p>When Intelligent Key is in the antenna detection area<br/>(The distance between Intelligent Key and antenna: 80 cm or less)</p>  <p style="text-align: right; font-size: small;">JMKIA5955GB</p>   |
| 80<br>(GR)                   | Ground | Passenger door antenna<br>(+) | Output           | When the passenger door request switch is operated with ignition switch ON | <p>When Intelligent Key is not in the antenna detection area<br/>(The distance between Intelligent Key and antenna: Approx. 2 m)</p>  <p style="text-align: right; font-size: small;">JMKIA5954GB</p> |
|                              |        |                               |                  | When the passenger door request switch is operated with ignition switch ON | <p>When Intelligent Key is in the antenna detection area<br/>(The distance between Intelligent Key and antenna: 80 cm or less)</p>  <p style="text-align: right; font-size: small;">JMKIA5955GB</p>   |

A  
B  
C  
D  
E  
F  
G  
H  
I  
J  
K  
L

BCS

N  
O  
P

# BCM

## < ECU DIAGNOSIS INFORMATION >

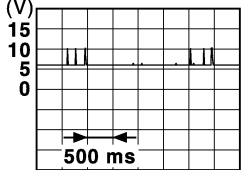
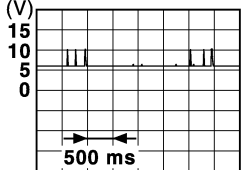
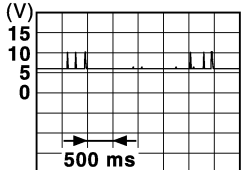
| Terminal No.<br>(Wire color) |        | Description                |                  | Condition  | Value<br>(Approx.)  |
|------------------------------|--------|----------------------------|------------------|--|---|
| +                            | -      | Signal name                | Input/<br>Output |  |   |
| 81<br>(BE)                   | Ground | Passenger door antenna (-) | Output           | When Intelligent Key is not in the antenna detection area<br>(The distance between Intelligent Key and antenna: Approx. 2 m) |  <p style="text-align: right; font-size: small;">JMkia5954GB</p>   |
|                              |        |                            |                  | When the passenger door request switch is operated with ignition switch ON   | When Intelligent Key is in the antenna detection area<br>(The distance between Intelligent Key and antenna: 80 cm or less)                            |
| 82<br>(G)                    | Ground | Rear bumper antenna (+)    | Output           | When Intelligent Key is not in the antenna detection area<br>(The distance between Intelligent Key and antenna: Approx. 2 m) |  <p style="text-align: right; font-size: small;">JMkia5954GB</p>  |
|                              |        |                            |                  | When the back door request switch is operated with ignition switch ON  | When Intelligent Key is in the antenna detection area<br>(The distance between Intelligent Key and antenna: 80 cm or less)                            |
| 83<br>(R)                    | Ground | Rear bumper antenna (-)    | Output           | When Intelligent Key is not in the antenna detection area<br>(The distance between Intelligent Key and antenna: Approx. 2 m) |  <p style="text-align: right; font-size: small;">JMkia5954GB</p> |
|                              |        |                            |                  | When the back door request switch is operated with ignition switch ON  | When Intelligent Key is in the antenna detection area<br>(The distance between Intelligent Key and antenna: 80 cm or less)                            |

# BCM

## < ECU DIAGNOSIS INFORMATION >

| Terminal No.<br>(Wire color) |        | Description                               |                  | Condition          | Value<br>(Approx.)  |
|------------------------------|--------|---|------------------|--------------------|---|
| +                            | -      | Signal name                               | Input/<br>Output |                    |   |
| 84<br>(GR)                   | Ground | Room antenna 1 (+)<br>(Instrument center) | Output           | Ignition switch ON | <p style="text-align: right; font-size: small;">JMKIA5951GB</p> |
|                              |        |   |                  | Ignition switch ON | <p style="text-align: right; font-size: small;">JMKIA3839GB</p> |
| 85<br>(B)                    | Ground | Room antenna 1 (-)<br>(Instrument center) | Output           | Ignition switch ON | <p style="text-align: right; font-size: small;">JMKIA5951GB</p> |
|                              |        |   |                  | Ignition switch ON | <p style="text-align: right; font-size: small;">JMKIA3839GB</p> |
| 86<br>(W)                    | Ground | Room antenna 2 (+)<br>(Console)           | Output           | Ignition switch ON | <p style="text-align: right; font-size: small;">JMKIA5951GB</p> |
|                              |        |   |                  | Ignition switch ON | <p style="text-align: right; font-size: small;">JMKIA3839GB</p> |

A  
B  
C  
D  
E  
F  
G  
H  
I  
J  
K  
L

BCS

N  
O  
P

# BCM

## < ECU DIAGNOSIS INFORMATION >

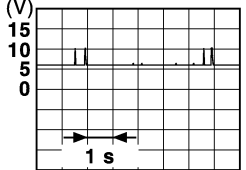
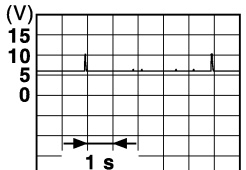
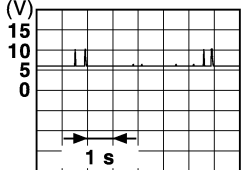
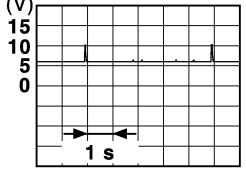
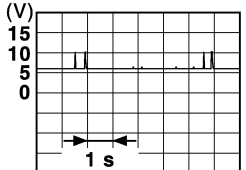
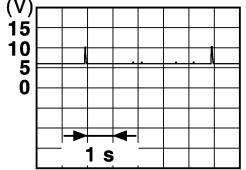
| Terminal No.<br>(Wire color) |        | Description                     |                  | Condition          | Value<br>(Approx.)   |
|------------------------------|--------|---------------------------------|------------------|--------------------|--|
| +                            | -      | Signal name                     | Input/<br>Output |                    |  |
| 87<br>(BE)                   | Ground | Room antenna 2 (-)<br>(Console) | Output           | Ignition switch ON | <p>When Intelligent Key is not in the antenna detection area</p>  <p style="text-align: right; font-size: small;">JMKIA5951GB</p>   |
|                              |        |                                 |                  | Ignition switch ON | <p>When Intelligent Key is in the antenna detection area</p>  <p style="text-align: right; font-size: small;">JMKIA3839GB</p>       |
| 88<br>(GR)                   | Ground | Luggage room antenna (+)        | Output           | Ignition switch ON | <p>When Intelligent Key is not in the antenna detection area</p>  <p style="text-align: right; font-size: small;">JMKIA5951GB</p>  |
|                              |        |                                 |                  | Ignition switch ON | <p>When Intelligent Key is in the antenna detection area</p>  <p style="text-align: right; font-size: small;">JMKIA3839GB</p>     |
| 89<br>(B)                    | Ground | Luggage room antenna (-)        | Output           | Ignition switch ON | <p>When Intelligent Key is not in the antenna detection area</p>  <p style="text-align: right; font-size: small;">JMKIA5951GB</p> |
|                              |        |                                 |                  | Ignition switch ON | <p>When Intelligent Key is in the antenna detection area</p>  <p style="text-align: right; font-size: small;">JMKIA3839GB</p>     |

# BCM

## < ECU DIAGNOSIS INFORMATION >

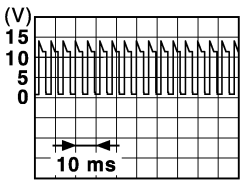
| Terminal No.<br>(Wire color) |        | Description  |                  | Condition                                |   | Value<br>(Approx.)   |
|------------------------------|--------|--|------------------|--|---|--|
| +                            | -      | Signal name  | Input/<br>Output |  |   |  |
| 90<br>(P)                    | Ground | Push-button ignition switch illumination           | Output           | Push-button ignition switch illumination | ON                                      | 9 – 16 V   |
|                              |        |  |                  |  | OFF                                     | 0 – 1.5 V  |
| 91<br>(W)                    | Ground | LOCK indicator lamp                                | Output           | LOCK indicator lamp                      | OFF (Ignition switch OFF)               | 9 – 16 V   |
|                              |        |  |                  |  | ON                                      | 0 – 1.5 V  |
| 92<br>(B)                    | Ground | Push-button ignition switch illumination ground    | Output           | Tail lamp                                | OFF                                     | 0 V  |
|                              |        |  |                  |  | ON                                      | <p><b>NOTE:</b><br/>When the illumination brightening/dimming level is in the neutral position</p>  <p style="text-align: right; font-size: small;">JPMIA1554GB</p> |
| 93<br>(R)                    | Ground | Intelligent Key warning buzzer                     | Output           | Intelligent Key warning buzzer           | Sounding                                | 0 – 1.5 V  |
| 96<br>(BE)                   | Ground | ACC relay control                                  | Output           | Ignition switch                          | OFF                                     | 0 – 0.5 V  |
|                              |        |  |                  |  | ACC or ON                               | 9 – 16 V   |
| 97<br>(W)                    | Ground | Starter relay control                              | Output           | Ignition switch ON                       | Other than engine cranking              | 9 – 16 V   |
|                              |        |  |                  |  | Engine cranking                         | 0 – 0.5 V  |
| 98<br>(P)                    | Ground | Ignition relay (IPDM E/R) control                  | Output           | Ignition switch                          | OFF or ACC                              | 9 – 16 V   |
|                              |        |  |                  |  | ON                                      | 0 – 0.5 V  |
| 99<br>(G)                    | Ground | Ignition relay control                             | Output           | Ignition switch                          | OFF or ACC                              | 0 – 0.5 V  |
|                              |        |  |                  |  | ON                                      | 9 – 16 V   |
| 100<br>(R)                   | Ground | Passenger door request switch                      | Input            | Passenger door request switch            | ON (Pressed)                            | 0 – 1.5 V  |
|                              |        |  |                  |  | OFF (Not pressed)                       | 9 – 16 V   |
| 101<br>(BR)                  | Ground | Ignition power supply No. 2                        | Output           | Ignition switch                          | OFF or ACC                              | 0 V  |
|                              |        |  |                  |  | ON                                      | 9 – 16 V   |
| 102<br>(P)                   | Ground | P/N position                                       | Input            | Selector lever                           | P or N position                         | 9 – 16 V   |
|                              |        |  |                  |  | Except P and N positions                | 0 – 1.5 V  |
| 104<br>(L)                   | Ground | CVT shift selector (detention switch) power supply | Output           | Ignition switch ON                       |   | 9 – 16 V   |
| 105<br>(R)                   | Ground | Stop lamp switch 2                                 | Input            | Ignition switch OFF                      |   | 9 – 16 V   |
| 106<br>(O)                   | Ground | Blower fan motor relay control                     | Output           | Ignition switch                          | OFF or ACC                              | 0 – 0.5 V  |
|                              |        |  |                  |  | ON                                      | 9 – 16 V   |
| 109<br>(R)                   | Ground | ACC indicator lamp                                 | Output           | Ignition switch                          | OFF (LOCK indicator is not illuminated) | 9 – 16 V   |
|                              |        |  |                  |  | ACC                                     | 0 – 1.5 V  |

- \*1: Without automatic sliding door system
- \*2: With automatic sliding door system
- \*3: With rear entertainment
- \*4: For Canada

## < ECU DIAGNOSIS INFORMATION >

- \*5: Without automatic back door system

### Fail-safe

INFOID:000000011324332

#### FAIL-SAFE CONTROL BY DTC

BCM performs fail-safe control when any DTC are detected.

| Display contents of CONSULT | Fail-safe   | Cancellation  |
|-----------------------------|---|---|
| B2192: ID DISCORD BCM-ECM   | Inhibit engine cranking                           | Erase DTC   |
| B2193: CHAIN OF BCM-ECM     | Inhibit engine cranking                           | Erase DTC   |
| B2195: ANTI-SCANNING        | Inhibit engine cranking                           | Ignition switch ON → OFF  |
| B2196: DONGLE NG            | Inhibit engine cranking                           | Erase DTC   |
| B2198: NATS ANTENNA AMP     | Inhibit engine cranking                           | Erase DTC   |
| B2608: STARTER RELAY        | Inhibit engine cranking                           | 500 ms after the following signal communication status becomes consistent <ul style="list-style-type: none"> <li>Starter motor relay control signal</li> <li>Starter relay status signal (CAN)</li> </ul>                               |
| B260F: ENG STATE SIG LOST   | Inhibit engine cranking                           | When any of the following conditions are fulfilled <ul style="list-style-type: none"> <li>Ignition switch changes to ACC</li> <li>Receives engine status signal (CAN)</li> </ul>  |
| B26F1: IGN RELAY OFF        | Inhibit engine cranking                           | When the following conditions are fulfilled <ul style="list-style-type: none"> <li>Ignition switch ON signal (CAN: Transmitted from BCM): ON</li> <li>Ignition switch ON signal (CAN: Transmitted from IPDM E/R): ON</li> </ul>         |
| B26F2: IGN RELAY ON         | Inhibit engine cranking                           | When the following conditions are fulfilled <ul style="list-style-type: none"> <li>Ignition switch ON signal (CAN: Transmitted from BCM): OFF</li> <li>Ignition switch ON signal (CAN: Transmitted from IPDM E/R): OFF</li> </ul>       |
| B26F3: START CONT RLY ON    | Inhibit engine cranking                           | When the following conditions are fulfilled <ul style="list-style-type: none"> <li>Starter control relay signal (CAN: Transmitted from BCM): OFF</li> <li>Starter control relay signal (CAN: Transmitted from IPDM E/R): OFF</li> </ul> |
| B26F4: START CONT RLY OFF   | Inhibit engine cranking                           | When the following conditions are fulfilled <ul style="list-style-type: none"> <li>Starter control relay signal (CAN: Transmitted from BCM): ON</li> <li>Starter control relay signal (CAN: Transmitted from IPDM E/R): ON</li> </ul>   |
| B26F7: BCM                  | Inhibit engine cranking by Intelligent Key system | When room antenna and luggage room antenna functions normally   |

#### REAR WIPER MOTOR PROTECTION

BCM detects the rear wiper stopping position according to the rear wiper stop position signal.

When the rear wiper stop position signal does not change for more than 5 seconds while driving the rear wiper, BCM stops power supply to protect the rear wiper motor.

Condition of cancellation

- More than 1 minute is passed after the rear wiper stop.
- Turn rear wiper switch OFF.
- Operate the rear wiper switch or rear washer switch.

#### FAIL-SAFE CONTROL OF COMBINATION SWITCH READING FUNCTION CAUSED BY LOW POWER SUPPLY VOLTAGE

If voltage of battery power supply lower, BCM maintains combination switch reading to the status when input voltage is less than approximately 9 V.

**NOTE:**

When voltage of battery power supply is approximately 9 V or more, combination switch reading function returns to normal operation.

#### DTC Inspection Priority Chart

INFOID:000000011324333

If some DTCs are displayed at the same time, perform inspections one by one based on the following priority chart.

# BCM

## < ECU DIAGNOSIS INFORMATION >

| Priority | DTC  | A                               |
|----------|--|---------------------------------|
| 1        | B2562: LOW VOLTAGE   | A                               |
| 2        | <ul style="list-style-type: none"> <li>• U1000: CAN COMM</li> <li>• U1010: CONTROL UNIT (CAN)</li> </ul>   | B                               |
| 3        | <ul style="list-style-type: none"> <li>• B2192: ID DISCORD BCM-ECM</li> <li>• B2193: CHAIN OF BCM-ECM</li> <li>• B2195: ANTI-SCANNING</li> <li>• B2196: DONGLE NG</li> <li>• B2198: NATS ANTENNA AMP</li> </ul>  | C                               |
| 4        | <ul style="list-style-type: none"> <li>• B2555: STOP LAMP</li> <li>• B2556: PUSH-BTN IGN SW</li> <li>• B2557: VEHICLE SPEED</li> <li>• B2601: SHIFT POSITION</li> <li>• B2602: SHIFT POSITION</li> <li>• B2603: SHIFT POSI STATUS</li> <li>• B2604: PNP/CLUTCH SW</li> <li>• B2605: PNP/CLUTCH SW</li> <li>• B2608: STARTER RELAY</li> <li>• B260F: ENG STATE SIG LOST</li> <li>• B2614: BCM</li> <li>• B2615: BCM</li> <li>• B2616: BCM</li> <li>• B2618: BCM</li> <li>• B261A: PUSH-BTN IGN SW</li> <li>• B26F1: IGN RELAY OFF</li> <li>• B26F2: IGN RELAY ON</li> <li>• B26F3: START CONT RLY ON</li> <li>• B26F4: START CONT RLY OFF</li> <li>• B26F6: BCM</li> <li>• B26F7: BCM</li> <li>• B26F8: BCM</li> <li>• B26F9: CRANK REQ CIR SHORT</li> <li>• B26FA: CRANK REQ CIR OPEN</li> <li>• B26FC: KEY REGISTRATION</li> <li>• C1729: VHCL SPEED SIG ERR</li> <li>• U0415: VEHICLE SPEED</li> </ul> | D<br>E<br>F<br>G<br>H<br>I<br>J |
| 5        | <ul style="list-style-type: none"> <li>• C1704: LOW PRESSURE FL</li> <li>• C1705: LOW PRESSURE FR</li> <li>• C1706: LOW PRESSURE RR</li> <li>• C1707: LOW PRESSURE RL</li> <li>• C1708: [NO DATA] FL</li> <li>• C1709: [NO DATA] FR</li> <li>• C1710: [NO DATA] RR</li> <li>• C1711: [NO DATA] RL</li> <li>• C1716: [PRESSDATA ERR] FL</li> <li>• C1717: [PRESSDATA ERR] FR</li> <li>• C1718: [PRESSDATA ERR] RR</li> <li>• C1719: [PRESSDATA ERR] RL</li> </ul>   | K<br>L                          |
| 5        | <ul style="list-style-type: none"> <li>• B2621: INSIDE ANTENNA</li> <li>• B2622: INSIDE ANTENNA</li> <li>• B2623: INSIDE ANTENNA</li> </ul>  | N<br>O                          |
| 6        | <ul style="list-style-type: none"> <li>• B2626: OUTSIDE ANTENNA</li> <li>• B2627: OUTSIDE ANTENNA</li> <li>• B2628: OUTSIDE ANTENNA</li> </ul>   | P                               |

BCS

### DTC Index

INFOID:0000000011324334

**NOTE:**

The details of time display are as follows.

- CRNT: A malfunction is detected now.
- PAST: A malfunction was detected in the past.

# BCM

## < ECU DIAGNOSIS INFORMATION >

IGN counter is displayed on Freeze Frame Data. For details of Freeze Frame Data, refer to [BCS-16, "COMMON ITEM : CONSULT Function \(BCM - COMMON ITEM\)"](#).

| CONSULT display                                      | Fail-safe | Freeze Frame Data<br>•Vehicle Speed<br>•Odo/Trip Meter<br>•Vehicle Condition | Intelligent Key warning lamp ON | Tire pressure monitor warning lamp ON | Reference page          |
|--|-----------|--|---------------------------------|---------------------------------------|-------------------------|
| No DTC is detected. further testing may be required. | —         | —  | —                               | —                                     | —                       |
| U1000: CAN COMM                                      | —         | —  | —                               | —                                     | <a href="#">BCS-87</a>  |
| U1010: CONTROL UNIT (CAN)                            | —         | —  | —                               | —                                     | <a href="#">BCS-88</a>  |
| U0415: VEHICLE SPEED                                 | —         | —  | ×                               | —                                     | <a href="#">BCS-89</a>  |
| B2192: ID DISCORD BCM-ECM                            | ×         | —  | —                               | —                                     | <a href="#">SEC-61</a>  |
| B2193: CHAIN OF BCM-ECM                              | ×         | —  | —                               | —                                     | <a href="#">SEC-62</a>  |
| B2195: ANTI-SCANNING                                 | ×         | —  | —                               | —                                     | <a href="#">SEC-63</a>  |
| B2196: DONGLE NG                                     | ×         | —  | —                               | —                                     | <a href="#">SEC-64</a>  |
| B2198: NATS ANTENNA AMP                              | ×         | —  | —                               | —                                     | <a href="#">SEC-66</a>  |
| B2555: STOP LAMP                                     | —         | ×  | ×                               | —                                     | <a href="#">SEC-69</a>  |
| B2556: PUSH-BTN IGN SW                               | —         | ×  | ×                               | —                                     | <a href="#">SEC-72</a>  |
| B2557: VEHICLE SPEED                                 | —         | ×  | ×                               | —                                     | <a href="#">SEC-74</a>  |
| B2562: LOW VOLTAGE                                   | —         | ×  | —                               | —                                     | <a href="#">BCS-90</a>  |
| B2601: SHIFT POSITION                                | —         | ×  | ×                               | —                                     | <a href="#">SEC-75</a>  |
| B2602: SHIFT POSITION                                | —         | ×  | ×                               | —                                     | <a href="#">SEC-77</a>  |
| B2603: SHIFT POSI STATUS                             | —         | ×  | ×                               | —                                     | <a href="#">SEC-80</a>  |
| B2604: PNP/CLUTCH SW                                 | —         | ×  | ×                               | —                                     | <a href="#">SEC-85</a>  |
| B2605: PNP/CLUTCH SW                                 | —         | ×  | ×                               | —                                     | <a href="#">SEC-88</a>  |
| B2608: STARTER RELAY                                 | ×         | ×  | ×                               | —                                     | <a href="#">SEC-91</a>  |
| B260F: ENG STATE SIG LOST                            | ×         | ×  | ×                               | —                                     | <a href="#">SEC-93</a>  |
| B2614: BCM   | —         | ×  | ×                               | —                                     | <a href="#">PCS-57</a>  |
| B2615: BCM   | —         | ×  | ×                               | —                                     | <a href="#">PCS-59</a>  |
| B2616: BCM   | —         | ×  | ×                               | —                                     | <a href="#">PCS-61</a>  |
| B2618: BCM   | —         | ×  | ×                               | —                                     | <a href="#">PCS-63</a>  |
| B261A: PUSH-BTN IGN SW                               | —         | ×  | ×                               | —                                     | <a href="#">PCS-65</a>  |
| B2621: INSIDE ANTENNA                                | —         | ×  | —                               | —                                     | <a href="#">DLK-226</a> |
| B2622: INSIDE ANTENNA                                | —         | ×  | —                               | —                                     | <a href="#">DLK-228</a> |
| B2623: INSIDE ANTENNA                                | —         | ×  | —                               | —                                     | <a href="#">DLK-230</a> |
| B2626: OUTSIDE ANTENNA                               | —         | ×  | —                               | —                                     | <a href="#">DLK-234</a> |
| B2627: OUTSIDE ANTENNA                               | —         | ×  | —                               | —                                     | <a href="#">DLK-232</a> |
| B2628: OUTSIDE ANTENNA                               | —         | ×  | —                               | —                                     | <a href="#">DLK-236</a> |
| B26F1: IGN RELAY OFF                                 | ×         | ×  | ×                               | —                                     | <a href="#">PCS-67</a>  |
| B26F2: IGN RELAY ON                                  | ×         | ×  | ×                               | —                                     | <a href="#">PCS-68</a>  |
| B26F3: START CONT RLY ON                             | ×         | ×  | ×                               | —                                     | <a href="#">SEC-96</a>  |
| B26F4: START CONT RLY OFF                            | ×         | ×  | ×                               | —                                     | <a href="#">SEC-97</a>  |
| B26F6: BCM   | —         | ×  | ×                               | —                                     | <a href="#">PCS-70</a>  |
| B26F7: BCM   | ×         | ×  | ×                               | —                                     | <a href="#">SEC-98</a>  |



# BCM

## < ECU DIAGNOSIS INFORMATION >

| CONSULT display            | Fail-safe | Freeze Frame Data<br>•Vehicle Speed<br>•Odo/Trip Meter<br>•Vehicle Condition | Intelligent Key warning lamp ON | Tire pressure monitor warning lamp ON | Reference page          |   |
|----------------------------|-----------|--|---------------------------------|---------------------------------------|-------------------------|---|
| B26F8: BCM                 | —         | ×  | ×                               | —                                     | <a href="#">SEC-99</a>  | A |
| B26F9: CRANK REQ CIR SHORT | —         | ×  | ×                               | —                                     | <a href="#">SEC-100</a> | B |
| B26FA: CRANK REQ CIR OPEN  | —         | ×  | ×                               | —                                     | <a href="#">SEC-102</a> | C |
| B26FC: KEY REGISTRATION    | —         | ×  | ×                               | —                                     | <a href="#">SEC-104</a> |   |
| C1704: LOW PRESSURE FL     | —         | —  | —                               | ×                                     | <a href="#">WT-25</a>   | D |
| C1705: LOW PRESSURE FR     | —         | —  | —                               | ×                                     |                         |   |
| C1706: LOW PRESSURE RR     | —         | —  | —                               | ×                                     |                         |   |
| C1707: LOW PRESSURE RL     | —         | —  | —                               | ×                                     |                         | E |
| C1708: [NO DATA] FL        | —         | —  | —                               | ×                                     | <a href="#">WT-27</a>   |   |
| C1709: [NO DATA] FR        | —         | —  | —                               | ×                                     |                         | F |
| C1710: [NO DATA] RR        | —         | —  | —                               | ×                                     |                         |   |
| C1711: [NO DATA] RL        | —         | —  | —                               | ×                                     |                         |   |
| C1716: [PRESSDATA ERR] FL  | —         | —  | —                               | ×                                     | <a href="#">WT-29</a>   | G |
| C1717: [PRESSDATA ERR] FR  | —         | —  | —                               | ×                                     |                         |   |
| C1718: [PRESSDATA ERR] RR  | —         | —  | —                               | ×                                     |                         | H |
| C1719: [PRESSDATA ERR] RL  | —         | —  | —                               | ×                                     |                         |   |
| C1729: VHCL SPEED SIG ERR  | —         | —  | —                               | ×                                     | <a href="#">WT-31</a>   | I |

BCS

N

O

P

# WIRING DIAGRAM

## BCM

### Wiring Diagram

INFOID:000000011324335

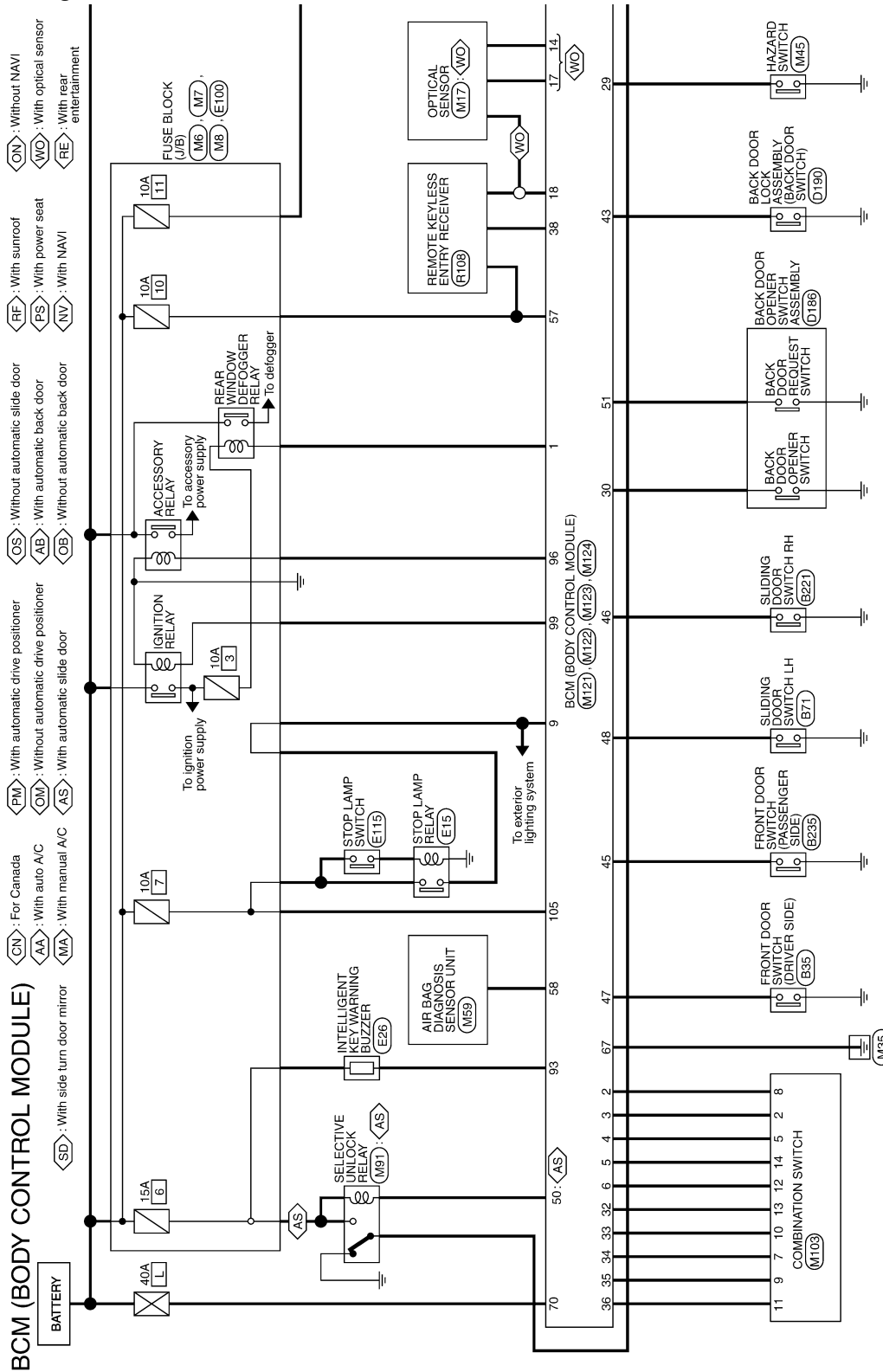

\*: This connector is not shown in "Harness Layout".

2014/07/25

JRMWG3281GB

# BCM

< WIRING DIAGRAM >

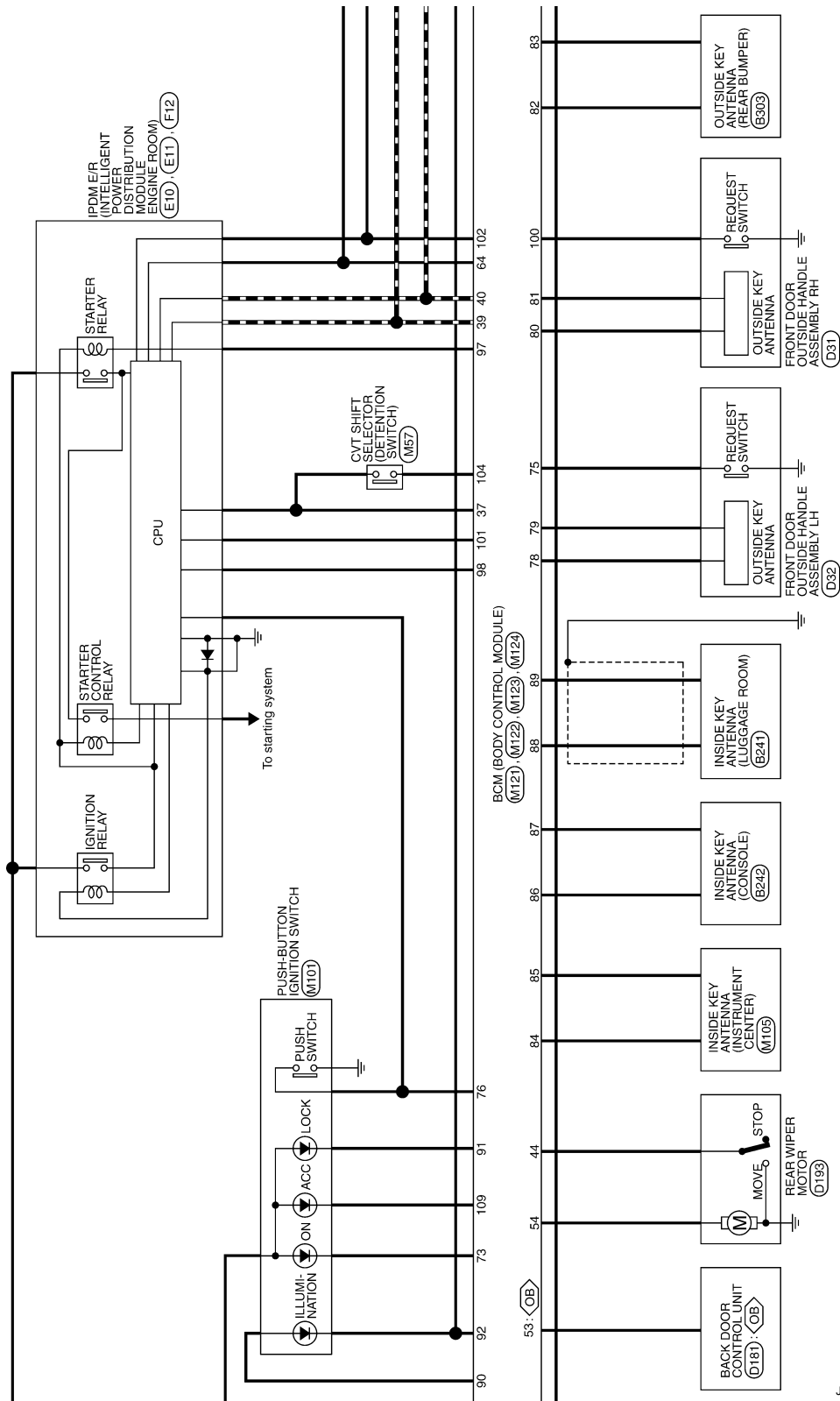

JRMWG3282GB

A  
B  
C  
D  
E  
F  
G  
H  
I  
J  
K  
L  
M  
N  
O  
P

BCS

# BCM

< WIRING DIAGRAM >

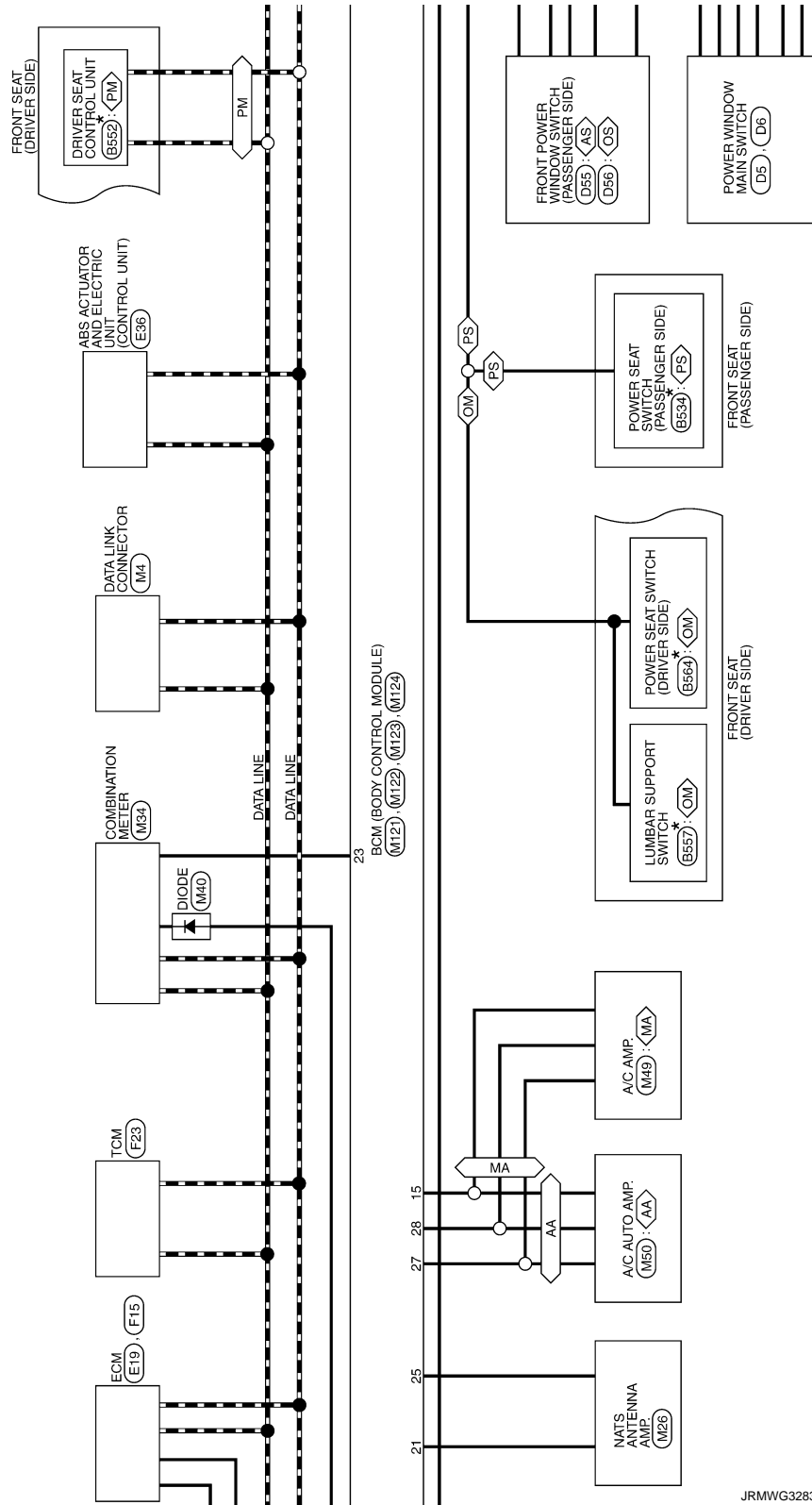

JRMWG3283GB

# BCM

< WIRING DIAGRAM >

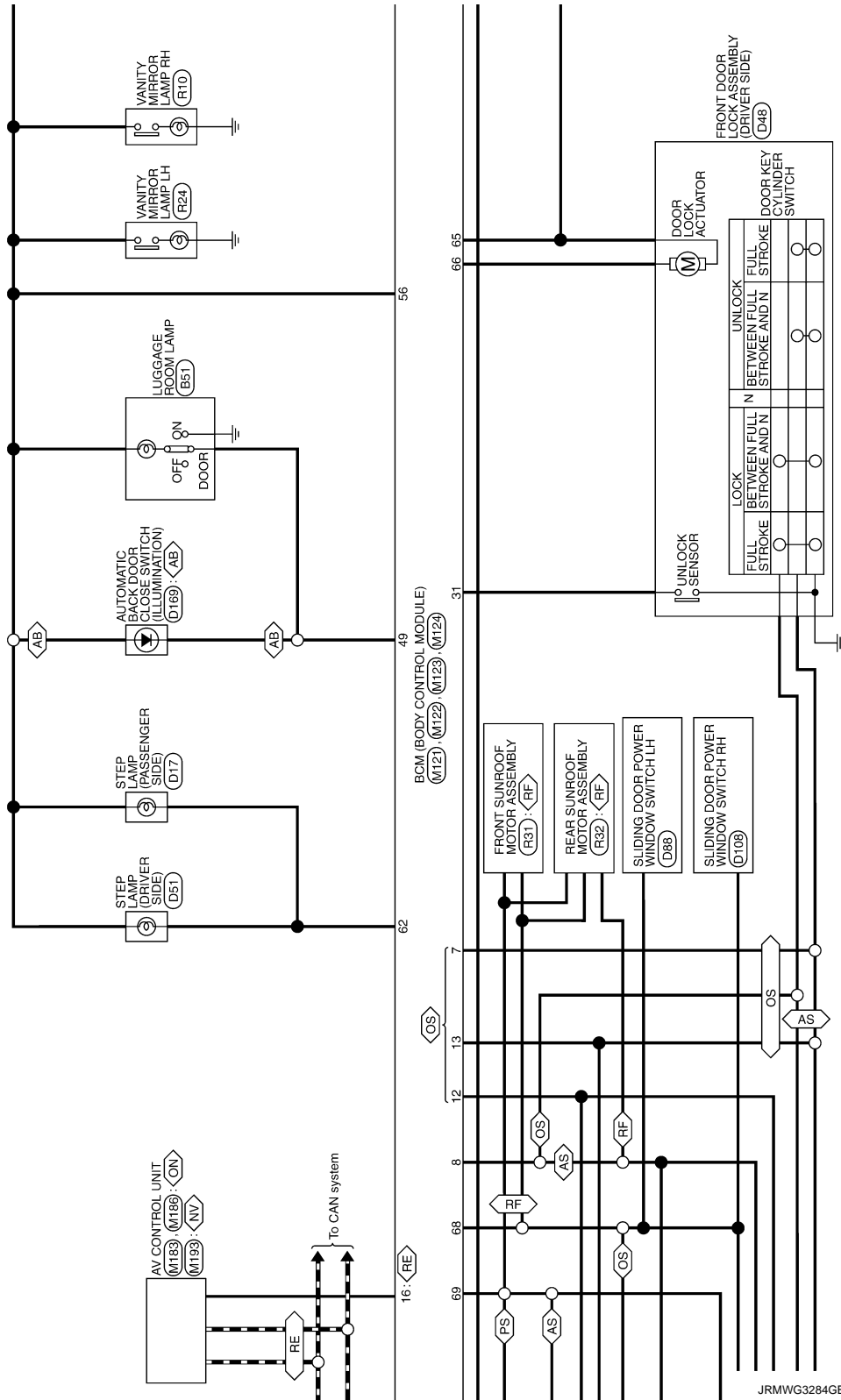

JRMWG3284GB

A  
B  
C  
D  
E  
F  
G  
H  
I  
J  
K  
L  
M  
N  
O  
P

BCS

# BCM

< WIRING DIAGRAM >

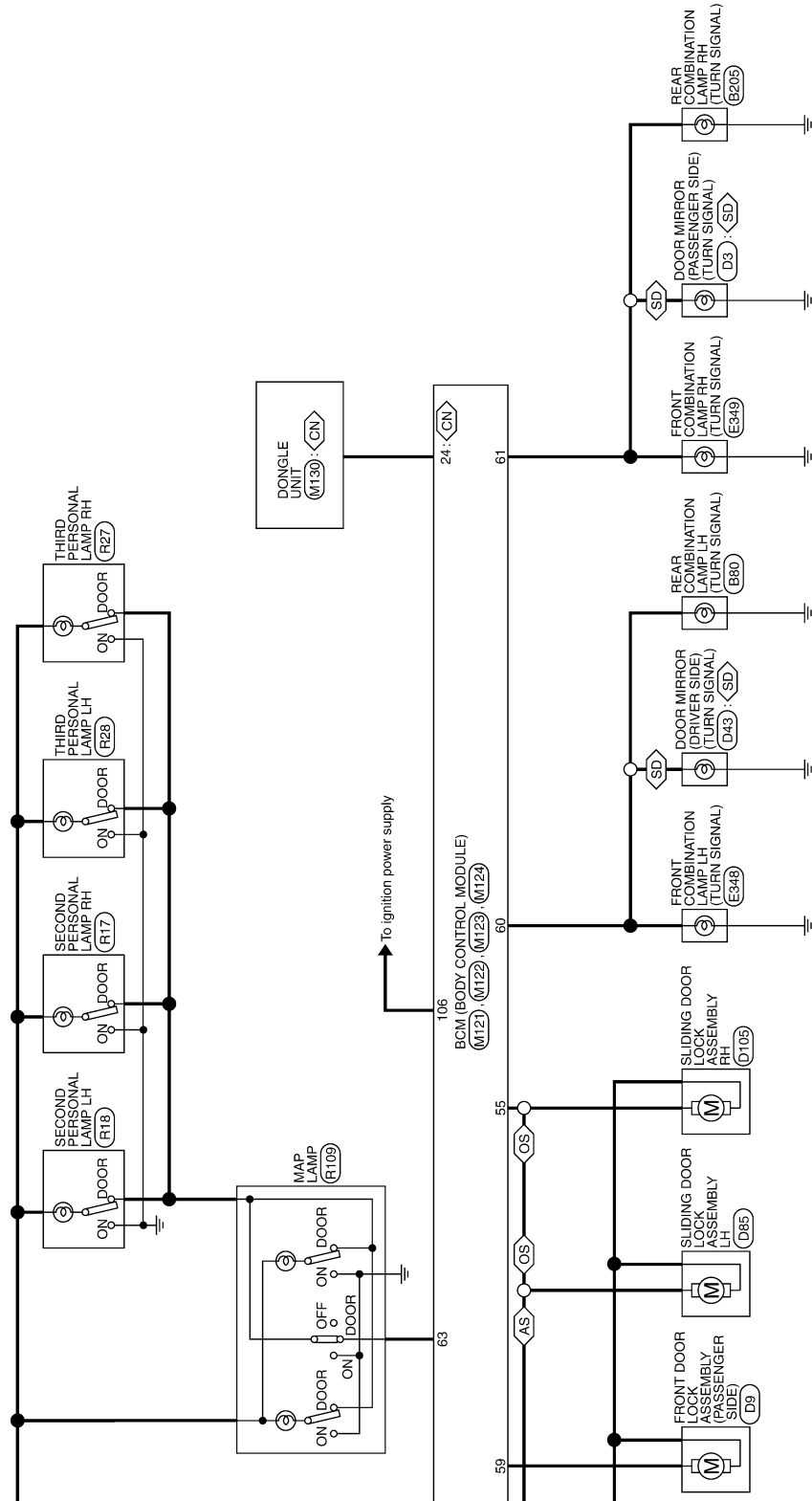

JRMWG3285GB

BCM (BODY CONTROL MODULE)

|                |                                 |
|----------------|---------------------------------|
| Connector No.  | B23                             |
| Connector Name | FRONT DOOR SWITCH (DRIVER SIDE) |
| Connector Type | TH04FW-NH                       |



| Terminal No. | Color Of Wire | Signal Name [Specification] |
|--------------|---------------|-----------------------------|
| 3            | Y             | -                           |

|                |                   |
|----------------|-------------------|
| Connector No.  | B51               |
| Connector Name | LUGGAGE ROOM LAMP |
| Connector Type | TR03FW            |



| Terminal No. | Color Of Wire | Signal Name [Specification] |
|--------------|---------------|-----------------------------|
| 2            | B             | -                           |
| 3            | G             | -                           |
| 4            | B             | -                           |

|                |                        |
|----------------|------------------------|
| Connector No.  | B71                    |
| Connector Name | SLIDING DOOR SWITCH LH |
| Connector Type | TH04FW-NH              |



| Terminal No. | Color Of Wire | Signal Name [Specification] |
|--------------|---------------|-----------------------------|
| 3            | GR            | -                           |

|                |                          |
|----------------|--------------------------|
| Connector No.  | B80                      |
| Connector Name | REAR COMBINATION LAMP LH |
| Connector Type | RSM4FGY-PR               |



| Terminal No. | Color Of Wire | Signal Name [Specification] |
|--------------|---------------|-----------------------------|
| 1            | P             | -                           |
| 2            | W             | -                           |
| 3            | B             | -                           |
| 4            | G             | -                           |

|                |                          |
|----------------|--------------------------|
| Connector No.  | B25                      |
| Connector Name | REAR COMBINATION LAMP RH |
| Connector Type | RSM4FGY-PR               |



| Terminal No. | Color Of Wire | Signal Name [Specification] |
|--------------|---------------|-----------------------------|
| 1            | R             | -                           |
| 2            | B             | -                           |
| 3            | B             | -                           |
| 4            | V             | -                           |

|                |                        |
|----------------|------------------------|
| Connector No.  | B221                   |
| Connector Name | SLIDING DOOR SWITCH RH |
| Connector Type | TH04FW-NH              |

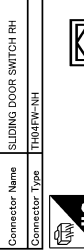

| Terminal No. | Color Of Wire | Signal Name [Specification] |
|--------------|---------------|-----------------------------|
| 3            | GR            | -                           |

|                |                                    |
|----------------|------------------------------------|
| Connector No.  | B235                               |
| Connector Name | FRONT DOOR SWITCH (PASSENGER SIDE) |
| Connector Type | TH04FW-NH                          |



| Terminal No. | Color Of Wire | Signal Name [Specification] |
|--------------|---------------|-----------------------------|
| 3            | SB            | -                           |

|                |                                   |
|----------------|-----------------------------------|
| Connector No.  | B241                              |
| Connector Name | INSIDE KEY ANTENNA (LUGGAGE ROOM) |
| Connector Type | FR02FL                            |



| Terminal No. | Color Of Wire | Signal Name [Specification] |
|--------------|---------------|-----------------------------|
| 1            | W             | -                           |
| 2            | B             | -                           |

A  
B  
C  
D  
E  
F  
G  
H  
I  
J  
K  
L  
N  
O  
P

BCS

JRMWG3286GB

**BCM (BODY CONTROL MODULE)**

|                |                              |
|----------------|------------------------------|
| Connector No.  | B242                         |
| Connector Name | INSIDE KEY ANTENNA (CONSOLE) |
| Connector Type | RK02FL                       |



| Terminal No. | Color Of Wire | Signal Name [Specification] |
|--------------|---------------|-----------------------------|
| 1            | W             | --                          |
| 2            | R             | --                          |

|                |                                   |
|----------------|-----------------------------------|
| Connector No.  | B303                              |
| Connector Name | OUTSIDE KEY ANTENNA (REAR BUMPER) |
| Connector Type | RK02FL                            |



| Terminal No. | Color Of Wire | Signal Name [Specification] |
|--------------|---------------|-----------------------------|
| 1            | R             | --                          |
| 2            | W             | --                          |

|                |                                    |
|----------------|------------------------------------|
| Connector No.  | B534                               |
| Connector Name | POWER SEAT SWITCH (PASSENGER SIDE) |
| Connector Type | NS10FW-CS                          |



| Terminal No. | Color Of Wire | Signal Name [Specification] |
|--------------|---------------|-----------------------------|
| 33           | R             | --                          |
| 34           | B             | --                          |
| 35           | G             | --                          |
| 38           | GR            | --                          |
| 39           | Y             | --                          |
| 43           | LG            | --                          |

|                |                          |
|----------------|--------------------------|
| Connector No.  | B532                     |
| Connector Name | DRIVER SEAT CONTROL UNIT |
| Connector Type | TH32FW-NH                |



| Terminal No. | Color Of Wire | Signal Name [Specification] |
|--------------|---------------|-----------------------------|
| 1            | R/Y           | CAN-H                       |
| 2            | R             | UART (TY/RX)                |
| 4            | R/L           | PULSE (RECLINER)            |
| 6            | R/W           | ADDRESS 2                   |
| 7            | R/G           | IND-2                       |
| 8            | SB            | SLIDE SW (BACKWARD)         |
| 9            | LB            | SLIDE SW (FORWARD)          |
| 10           | L/B           | FRONT LIFTER SW (DOWNWARD)  |
| 11           | L/W           | REAR LIFTER SW (DOWNWARD)   |
| 12           | L/R           | SENSOR POWER SUPPLY         |
| 17           | V             | CAN-L                       |
| 18           | B/W           | PULSE (SLIDE)               |
| 19           | B/R           | PULSE (FRONT LIFTER)        |
| 20           | B/L           | PULSE (REAR LIFTER)         |

|    |     |                          |
|----|-----|--------------------------|
| 23 | W/L | ADDRESS 1                |
| 24 | W/B | IND-1                    |
| 24 | V/W | SLIDE SW (FORWARD)       |
| 25 | Y/B | RECLINER SW (FORWARD)    |
| 26 | Y/R | FRONT LIFTER SW (UPWARD) |
| 27 | Y/L | REAR LIFTER SW (UPWARD)  |
| 28 | G   | SET SW                   |

|                |                       |
|----------------|-----------------------|
| Connector No.  | B517                  |
| Connector Name | LUMBAR SUPPORT SWITCH |
| Connector Type | NS10FW-CS             |

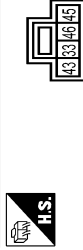

| Terminal No. | Color Of Wire | Signal Name [Specification] |
|--------------|---------------|-----------------------------|
| 33           | R             | --                          |
| 43           | LG            | --                          |
| 45           | P             | --                          |
| 46           | BR            | --                          |

|                |                                 |
|----------------|---------------------------------|
| Connector No.  | B534                            |
| Connector Name | POWER SEAT SWITCH (DRIVER SIDE) |
| Connector Type | NS10FW-CS                       |



| Terminal No. | Color Of Wire | Signal Name [Specification] |
|--------------|---------------|-----------------------------|
| 33           | R             | --                          |
| 34           | B             | --                          |
| 35           | G             | --                          |
| 36           | L             | --                          |
| 38           | GR            | --                          |
| 39           | Y             | --                          |
| 40           | W             | --                          |

|    |     |    |
|----|-----|----|
| 41 | V   | -- |
| 42 | P/B | -- |
| 43 | LG  | -- |

|                |                              |
|----------------|------------------------------|
| Connector No.  | B3                           |
| Connector Name | DOOR MIRROR (PASSENGER SIDE) |
| Connector Type | TH24MM-NH                    |



| Terminal No. | Color Of Wire | Signal Name [Specification] |
|--------------|---------------|-----------------------------|
| 1            | L             | --                          |
| 5            | W             | --                          |
| 6            | R             | --                          |
| 7            | P             | --                          |
| 10           | W             | --                          |
| 11           | G             | --                          |
| 12           | R             | --                          |
| 13           | Y             | --                          |
| 17           | SHIELD        | --                          |
| 19           | B             | --                          |
| 20           | LG            | --                          |
| 21           | R             | --                          |
| 22           | P             | --                          |
| 23           | W             | --                          |
| 24           | GR            | --                          |



BCM (BODY CONTROL MODULE)

|                |                          |
|----------------|--------------------------|
| Connector No.  | D5                       |
| Connector Name | POWER WINDOW MAIN SWITCH |
| Connector Type | NSD3FW-CS                |



|                |   |
|----------------|---|
| Connector No.  | D9  |
| Connector Name | FRONT DOOR LOCK ASSEMBLY (PASSENGER SIDE) |
| Connector Type | ED8FGY-RS                                 |



|                |   |
|----------------|---|
| Connector No.  | D31                                     |
| Connector Name | FRONT DOOR OUTSIDE HANDLE ASSEMBLY (RH) |
| Connector Type | RHD4MB                                  |



|                |                           |
|----------------|---------------------------|
| Connector No.  | D43                       |
| Connector Name | DOOR MIRROR (DRIVER SIDE) |
| Connector Type | TH24MW-NH                 |



| Terminal No. | Color Of Wire | Signal Name [Specification] |
|--------------|---------------|-----------------------------|
| 1            | GR            | -                           |
| 2            | BR            | -                           |
| 3            | LG            | -                           |
| 4            | GR            | -                           |
| 5            | SB            | -                           |
| 6            | GR            | -                           |
| 7            | V             | -                           |
| 8            | L             | -                           |
| 9            | W             | -                           |
| 10           | GR            | -                           |
| 11           | Y             | -                           |
| 12           | LG            | -                           |
| 13           | GR            | -                           |
| 14           | R             | -                           |
| 15           | G             | -                           |
| 16           | L             | -                           |

|              |      |                             |
|--------------|------|-----------------------------|
| Terminal No. | Wire | Signal Name [Specification] |
| 1            | GR   | -                           |
| 2            | BR   | -                           |
| 3            | LG   | -                           |

|                |                            |
|----------------|----------------------------|
| Connector No.  | D17                        |
| Connector Name | STEP LAMP (PASSENGER SIDE) |
| Connector Type | TR02FW                     |



|              |               |                             |
|--------------|---------------|-----------------------------|
| Terminal No. | Color Of Wire | Signal Name [Specification] |
| 1            | GR            | -                           |
| 2            | BR            | -                           |
| 3            | LG            | -                           |
| 4            | B             | -                           |

|                |  |
|----------------|--|
| Connector No.  | D32                                    |
| Connector Name | FRONT DOOR OUTSIDE HANDLE ASSEMBLY (L) |
| Connector Type | RHD4MB                                 |



| Terminal No. | Color Of Wire | Signal Name [Specification] |
|--------------|---------------|-----------------------------|
| 1            | L             | -                           |
| 2            | W             | -                           |
| 3            | W             | -                           |
| 4            | P             | -                           |
| 5            | P             | -                           |
| 6            | G             | -                           |
| 7            | GR            | -                           |
| 8            | Y             | -                           |
| 9            | SHIELD        | -                           |
| 10           | B             | -                           |
| 11           | B             | -                           |
| 12           | LG            | -                           |
| 13           | P             | -                           |
| 14           | R             | -                           |
| 15           | W             | -                           |
| 16           | G             | -                           |

|                |                          |
|----------------|--------------------------|
| Connector No.  | D6                       |
| Connector Name | POWER WINDOW MAIN SWITCH |
| Connector Type | NSD3FW-CS                |



|              |               |                             |
|--------------|---------------|-----------------------------|
| Terminal No. | Color Of Wire | Signal Name [Specification] |
| 1            | W             | -                           |
| 2            | G             | -                           |

|              |               |                             |
|--------------|---------------|-----------------------------|
| Terminal No. | Color Of Wire | Signal Name [Specification] |
| 1            | GR            | -                           |
| 2            | G             | -                           |
| 3            | R             | -                           |
| 4            | B             | -                           |

|                |  |
|----------------|--|
| Connector No.  | D48                                    |
| Connector Name | FRONT DOOR LOCK ASSEMBLY (DRIVER SIDE) |
| Connector Type | ED8FGY-RS                              |



| Terminal No. | Color Of Wire | Signal Name [Specification] |
|--------------|---------------|-----------------------------|
| 17           | B             | -                           |
| 18           | G             | -                           |
| 19           | Y             | -                           |

| Terminal No. | Color Of Wire | Signal Name [Specification] |
|--------------|---------------|-----------------------------|
| 1            | BR            | -                           |
| 2            | LG            | -                           |
| 3            | W             | -                           |
| 4            | B             | -                           |

| Terminal No. | Color Of Wire | Signal Name [Specification] |
|--------------|---------------|-----------------------------|
| 1            | BR            | -                           |
| 2            | LG            | -                           |
| 3            | W             | -                           |
| 4            | B             | -                           |

A  
B  
C  
D  
E  
F  
G  
H  
I  
J  
K  
L  
N  
O  
P

BCS

JRMWG3288GB

BCM (BODY CONTROL MODULE)

|   |    |   |
|---|----|---|
| 2 | GR | - |
| 3 | G  | - |

|                |                         |
|----------------|-------------------------|
| Connector No.  | D51                     |
| Connector Name | STEP LAMP (DRIVER SIDE) |
| Connector Type | TK02FW                  |



| Terminal No. | Color Of Wire | Signal Name [Specification] |
|--------------|---------------|-----------------------------|
| 1            | W             | -                           |
| 2            | G             | -                           |

|                |  |
|----------------|--|
| Connector No.  | D55  |
| Connector Name | FRONT POWER WINDOW SWITCH (PASSENGER SIDE) |
| Connector Type | NS12FW-CS                                  |

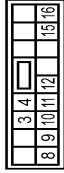

| Terminal No. | Color Of Wire | Signal Name [Specification] |
|--------------|---------------|-----------------------------|
| 3            | GR            | -                           |
| 4            | G             | -                           |
| 8            | L             | -                           |
| 9            | LG            | -                           |
| 10           | V             | -                           |
| 11           | B             | -                           |
| 15           | R             | -                           |
| 16           | W             | -                           |

|                |  |
|----------------|--|
| Connector No.  | D56  |
| Connector Name | FRONT POWER WINDOW SWITCH (PASSENGER SIDE) |
| Connector Type | NS12FW-CS                                  |

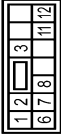

| Terminal No. | Color Of Wire | Signal Name [Specification] |
|--------------|---------------|-----------------------------|
| 1            | GR            | -                           |
| 2            | G             | -                           |
| 3            | B             | -                           |
| 6            | LG            | -                           |
| 7            | L             | -                           |
| 8            | V             | -                           |
| 11           | LG            | -                           |
| 12           | BR            | -                           |

|                |                               |
|----------------|-------------------------------|
| Connector No.  | D65                           |
| Connector Name | SLIDING DOOR LOCK ASSEMBLY LH |
| Connector Type | SC102FGY                      |



| Terminal No. | Color Of Wire | Signal Name [Specification] |
|--------------|---------------|-----------------------------|
| 1            | Y             | -                           |
| 2            | L             | -                           |

|                |                                     |
|----------------|-------------------------------------|
| Connector No.  | D68                                 |
| Connector Name | SLIDING DOOR POWER WINDOW SWITCH LH |
| Connector Type | NS08FW-CS                           |

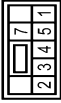

| Terminal No. | Color Of Wire | Signal Name [Specification] |
|--------------|---------------|-----------------------------|
| 2            | SB            | -                           |
| 3            | P             | -                           |
| 4            | LG            | -                           |
| 5            | L             | -                           |
| 7            | B             | -                           |

|                |                               |
|----------------|-------------------------------|
| Connector No.  | D105                          |
| Connector Name | SLIDING DOOR LOCK ASSEMBLY RH |
| Connector Type | SC102FGY                      |



| Terminal No. | Color Of Wire | Signal Name [Specification] |
|--------------|---------------|-----------------------------|
| 1            | Y             | -                           |
| 2            | L             | -                           |

|                |                                     |
|----------------|-------------------------------------|
| Connector No.  | D108                                |
| Connector Name | SLIDING DOOR POWER WINDOW SWITCH RH |
| Connector Type | NS08FW-CS                           |

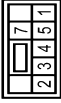

| Terminal No. | Color Of Wire | Signal Name [Specification] |
|--------------|---------------|-----------------------------|
| 2            | SB            | -                           |
| 3            | P             | -                           |
| 4            | LG            | -                           |
| 5            | L             | -                           |
| 7            | GR            | -                           |

|                |                                  |
|----------------|----------------------------------|
| Connector No.  | D109                             |
| Connector Name | AUTOMATIC BACK DOOR CLOSE SWITCH |
| Connector Type | TK06FGY                          |



| Terminal No. | Color Of Wire | Signal Name [Specification] |
|--------------|---------------|-----------------------------|
| 1            | G             | -                           |
| 2            | B             | -                           |
| 3            | W             | -                           |
| 4            | LG            | -                           |

BCM (BODY CONTROL MODULE)

|                |                        |
|----------------|------------------------|
| Connector No.  | D181                   |
| Connector Name | BACK DOOR CONTROL UNIT |
| Connector Type | NS30FW-CS              |



| Terminal No. | Color Of Wire | Signal Name [Specification] |
|--------------|---------------|-----------------------------|
| 1            | W             | CLOSE                       |
| 2            | G             | PROP                        |
| 3            | L             | CLOSE                       |
| 4            | V             | OPEN                        |
| 5            | R             | DR LOCK STATUS              |
| 6            | P             | OPEN SW                     |
| 7            | B             | DR LOCK STATUS              |
| 8            | GR            | EARTH                       |
| 10           | BR            | OPEN                        |

|                |                                   |
|----------------|-----------------------------------|
| Connector No.  | D186                              |
| Connector Name | BACK DOOR OPERIER SWITCH ASSEMBLY |
| Connector Type | TH40MP-NH                         |



| Terminal No. | Color Of Wire | Signal Name [Specification] |
|--------------|---------------|-----------------------------|
| 1            | R             | -                           |
| 2            | B             | -                           |
| 3            | B             | -                           |
| 4            | W             | -                           |

|                |                         |
|----------------|-------------------------|
| Connector No.  | D193                    |
| Connector Name | BACK DOOR LOCK ASSEMBLY |
| Connector Type | NS30FW-CS               |

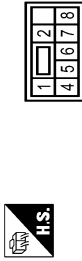

| Terminal No. | Color Of Wire | Signal Name [Specification] |
|--------------|---------------|-----------------------------|
| 1            | BR            | -                           |
| 2            | P             | -                           |
| 3            | R             | -                           |
| 4            | W             | -                           |
| 5            | W             | -                           |
| 6            | G             | -                           |
| 7            | P             | -                           |
| 8            | B             | -                           |

|                |                  |
|----------------|------------------|
| Connector No.  | D193             |
| Connector Name | REAR WIPER MOTOR |
| Connector Type | CJ04FW-1V        |



| Terminal No. | Color Of Wire | Signal Name [Specification] |
|--------------|---------------|-----------------------------|
| 1            | SB            | -                           |
| 3            | B             | -                           |
| 4            | GR            | -                           |

|                |   |
|----------------|---|
| Connector No.  | E10   |
| Connector Name | INTELLIGENT POWER DISTRIBUTION MODULE ENGINE ROOM |
| Connector Type | TH20FW-CS2-M4-1V                                  |



| Terminal No. | Color Of Wire | Signal Name [Specification] |
|--------------|---------------|-----------------------------|
| 4            | LG            | -                           |
| 5            | G             | -                           |
| 6            | B             | -                           |
| 7            | BR            | -                           |
| 10           | P             | -                           |
| 12           | B             | -                           |
| 13           | G             | -                           |
| 15           | L             | -                           |
| 16           | R             | -                           |
| 18           | P             | -                           |
| 19           | V             | -                           |
| 20           | W             | -                           |
| 21           | O             | -                           |
| 22           | SB            | -                           |
| 23           | GR            | -                           |
| 24           | GR            | -                           |
| 25           | GR            | -                           |
| 27           | BR            | -                           |
| 28           | G             | -                           |
| 30           | LG            | -                           |
| 34           | O             | -                           |
| 35           | P             | -                           |
| 36           | G             | -                           |
| 38           | GR            | -                           |

|                |                 |
|----------------|-----------------|
| Connector No.  | E15             |
| Connector Name | STOP LAMP RELAY |
| Connector Type | MS2FL-M2-LC     |



| Terminal No. | Color Of Wire | Signal Name [Specification] |
|--------------|---------------|-----------------------------|
| 1            | B/W           | -                           |
| 2            | LG            | -                           |
| 3            | R             | -                           |
| 5            | P             | -                           |

|                |   |
|----------------|---|
| Connector No.  | E11   |
| Connector Name | INTELLIGENT POWER DISTRIBUTION MODULE ENGINE ROOM |
| Connector Type | TH40FW-NH   |



| Terminal No. | Color Of Wire | Signal Name [Specification] |
|--------------|---------------|-----------------------------|
| 39           | P             | -                           |
| 40           | B             | -                           |
| 42           | SB            | -                           |
| 43           | LG            | -                           |
| 44           | W             | -                           |
| 45           | Y             | -                           |
| 46           | O             | -                           |

|                |                 |
|----------------|-----------------|
| Connector No.  | E15             |
| Connector Name | STOP LAMP RELAY |
| Connector Type | MS2FL-M2-LC     |



| Terminal No. | Color Of Wire | Signal Name [Specification] |
|--------------|---------------|-----------------------------|
| 1            | B/W           | -                           |
| 2            | LG            | -                           |
| 3            | R             | -                           |
| 5            | P             | -                           |

A  
B  
C  
D  
E  
F  
G  
H  
I  
J  
K  
L  
N  
O  
P



JRMWG3290GB

BCM (BODY CONTROL MODULE)

|                |                 |
|----------------|-----------------|
| Connector No.  | E19             |
| Connector Name | ECM             |
| Connector Type | RH24EB-R28-L-LH |

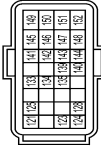

| Terminal No. | Color Of Wire | Signal Name [Specification]         |
|--------------|---------------|-------------------------------------|
| 121          | LG            | EVAP CONTROL SYSTEM PRESSURE SENSOR |
| 122          | P             | CAN COMMUNICATION LINE (CAN-L)      |
| 124          | L             | CAN COMMUNICATION LINE (CAN-H)      |
| 125          | W             | SENSOR POWER SUPPLY                 |
| 128          | Y             | FUEL TANK TEMPERATURE SENSOR        |
| 133          | BR            | IGNITION SWITCH                     |
| 134          | Y             | ASC/D STEERING SWITCH               |
| 135          | BR            | SENSOR GROUND                       |
| 139          | SB            | STOP LAMP SWITCH                    |
| 140          | BR            | BRAKE PEDAL POSITION SWITCH         |
| 141          | Y             | EVAP CANISTER VENT CONTROL VALVE    |
| 142          | GR            | SENSOR POWER SUPPLY                 |
| 143          | O             | ACCELERATOR PEDAL POSITION SENSOR 2 |
| 144          | G             | SENSOR GROUND                       |
| 145          | L             | POWER WINDOW                        |
| 146          | B             | SENSOR POWER SUPPLY                 |
| 147          | B             | ECM GROUND                          |
| 148          | V             | SENSOR GROUND                       |
| 149          | B             | ECM GROUND                          |
| 150          | W             | ACCELERATOR PEDAL POSITION SENSOR 1 |
| 151          | B             | SENSOR GROUND                       |
| 152          | B             | ECM GROUND                          |

|                |                                |
|----------------|--------------------------------|
| Connector No.  | E28                            |
| Connector Name | INTELLIGENT KEY WARNING BUZZER |
| Connector Type | RK03FBR                        |



| Terminal No. | Color Of Wire | Signal Name [Specification] |
|--------------|---------------|-----------------------------|
| 1            | GR            |                             |
| 2            | GR            |                             |
| 3            | GR            |                             |

|                |   |
|----------------|---|
| Connector No.  | E36   |
| Connector Name | ABS ACTUATOR AND ELECTRIC UNIT (CONTROL UNIT) |
| Connector Type | AZZZFE-AJZ-LH                                 |

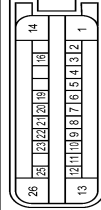

| Terminal No. | Color Of Wire | Signal Name [Specification]     |
|--------------|---------------|---------------------------------|
| 1            | R             | VALVE BATTERY                   |
| 2            | Y             | RR LH WHEEL SENSOR SIGNAL       |
| 3            | L             | RR LH WHEEL SENSOR POWER SUPPLY |
| 4            | G             | G SENSOR POWER SUPPLY           |
| 5            | B             | FR RH WHEEL SENSOR POWER SUPPLY |
| 6            | W             | FR RH WHEEL SENSOR SIGNAL       |
| 7            | V             | BRAKE FLUID LEVEL SWITCH SIGNAL |
| 8            | LG            | FR LH WHEEL SENSOR SIGNAL       |
| 9            | L             | FR LH WHEEL SENSOR POWER SUPPLY |
| 10           | B             | G SENSOR GND                    |
| 11           | P             | RR RH WHEEL SENSOR POWER SUPPLY |
| 12           | P             | RR RH WHEEL SENSOR SIGNAL       |
| 13           | B             | GROUND                          |
| 14           | G             | MOTOR BATTERY                   |
| 16           | SB            | STOP LAMP SWITCH SIGNAL         |
| 19           | Y             | G SENSOR SIGNAL (+)             |
| 20           | GR            | IGN                             |
| 21           | P             | CAN-L                           |

|    |    |                       |
|----|----|-----------------------|
| 22 | BR | VDC OFF SWITCH SIGNAL |
| 23 | O  | CAN-L                 |
| 25 | O  | G SENSOR SIGNAL (-)   |
| 26 | B  | GROUND                |

|                |                  |
|----------------|------------------|
| Connector No.  | E100             |
| Connector Name | FUSE BLOCK (J/B) |
| Connector Type | NS16FW-CS        |

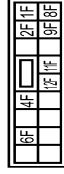

| Terminal No. | Color Of Wire | Signal Name [Specification] |
|--------------|---------------|-----------------------------|
| 11F          | G             |                             |
| 12F          | V             |                             |
| 1F           | SB            |                             |
| 2F           | R             |                             |
| 4F           | L             |                             |
| 8F           | LG            |                             |
| 9F           | P             |                             |
| 9F           | BR            |                             |

|                |                  |
|----------------|------------------|
| Connector No.  | E15              |
| Connector Name | STOP LAMP SWITCH |
| Connector Type | MG4FW-LC         |



| Terminal No. | Color Of Wire | Signal Name [Specification] |
|--------------|---------------|-----------------------------|
| 1            | P             |                             |
| 2            | LG            |                             |
| 3            | O             |                             |
| 4            | W             |                             |

|                |                           |
|----------------|---------------------------|
| Connector No.  | E34B                      |
| Connector Name | FRONT COMBINATION LAMP LH |
| Connector Type | Z03FBR                    |



| Terminal No. | Color Of Wire | Signal Name [Specification] |
|--------------|---------------|-----------------------------|
| 1            | P             |                             |
| 2            | B             |                             |
| 3            | G             |                             |

|                |                           |
|----------------|---------------------------|
| Connector No.  | E349                      |
| Connector Name | FRONT COMBINATION LAMP RH |
| Connector Type | Z03FBR                    |



| Terminal No. | Color Of Wire | Signal Name [Specification] |
|--------------|---------------|-----------------------------|
| 1            | W             |                             |
| 2            | GR            |                             |
| 3            | W             |                             |

A  
B  
C  
D  
E  
F  
G  
H  
I  
J  
K  
L  
N  
O  
P

BCM (BODY CONTROL MODULE)

|                |   |
|----------------|---|
| Connector No.  | F12   |
| Connector Name | INTELLIGENT POWER DISTRIBUTION MODULE ENGINE ROOM |
| Connector Type | TH20FW-CS12-M4                                    |

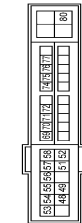

| Terminal No. | Color Of Wire | Signal Name [Specification] |
|--------------|---------------|-----------------------------|
| 48           | W             | -                           |
| 49           | R             | -                           |
| 51           | LG            | -                           |
| 52           | Y/G           | -                           |
| 53           | R/W           | -                           |
| 54           | G/W           | -                           |
| 55           | W/L           | -                           |
| 56           | R/Y           | -                           |
| 57           | O             | -                           |
| 58           | Y             | -                           |
| 69           | W/B           | -                           |
| 70           | O             | -                           |
| 71           | P             | -                           |
| 72           | R/B           | -                           |
| 74           | LG            | -                           |
| 76           | GR            | -                           |
| 77           | B             | -                           |
| 80           | B             | -                           |

|                |                  |
|----------------|------------------|
| Connector No.  | F15              |
| Connector Name | ECM              |
| Connector Type | IMB55FB-MEB10-LH |

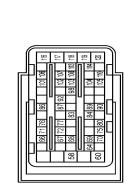

| Terminal No. | Color Of Wire | Signal Name [Specification]                         |
|--------------|---------------|---|
| 52           | R/B           | E-CVT#1   |
| 53           | W             | E-CVT#2   |
| 64           | G/B           | SENSOR GROUND                                       |
| 66           | L             | A/F SENSOR 1 (BANK 1)                               |
| 67           | P             | A/F SENSOR 1 (BANK 1)                               |
| 68           | W             | BATTERY TEMPERATURE SENSOR                          |
| 69           | BR            | BATTERY CURRENT SENSOR                              |
| 70           | GR            | SHIELD  |
| 71           | W             | THROTTLE POSITION SENSOR 1                          |
| 72           | R             | THROTTLE POSITION SENSOR 2                          |
| 75           | B             | SENSOR GROUND                                       |
| 76           | LG            | A/F SENSOR 1 (BANK 2)                               |
| 77           | GR            | A/F SENSOR 2 (BANK 2)                               |
| 78           | R             | CRP SIGNAL  |
| 84           | W/R           | CAMSHAFT POSITION SENSOR (BANK 1)                   |
| 85           | R             | CRP SIGNAL  |
| 86           | W/B           | ECM RELAY (SELF-SHUT-OFF)                           |
| 87           | R/Y           | SENSOR POWER SUPPLY                                 |
| 89           | BR/W          | CAMSHAFT POSITION SENSOR (BANK 2)                   |
| 90           | B/R           | SENSOR GROUND                                       |
| 92           | G/W           | SENSOR POWER SUPPLY                                 |
| 101          | P             | STARTER MOTOR RELAY OUT OFF SIGNAL                  |
| 102          | GR/B          | WAS CONTROL SOLENOID VALVE 2                        |
| 103          | L/B           | IGNITION SIGNAL No. 3                               |
| 104          | GR/R          | IGNITION SIGNAL No. 6                               |
| 105          | B             | ECM GROUND  |
| 106          | R             | IGNITION SIGNAL No. 2                               |
| 107          | P             | IGNITION SIGNAL No. 5                               |
| 108          | V             | WAS CONTROL SOLENOID VALVE 1                        |
| 110          | B             | ECM GROUND  |
| 113          | Y/R           | IGNITION SIGNAL No. 1                               |
| 114          | W             | IGNITION SIGNAL No. 4                               |
| 116          | W/L           | POWER SUPPLY FOR ECM (BACK-UP)                      |
| 117          | R             | INTAKE VALVE TIMING CONTROL SOLENOID VALVE (BANK 1) |
| 118          | V             | INTAKE VALVE TIMING CONTROL SOLENOID VALVE (BANK 2) |
| 119          | Y             | INTAKE VALVE TIMING CONTROL SOLENOID VALVE (BANK 2) |
| 120          | BR            | IGNITION POWER SUPPLY                               |

|                |                 |
|----------------|-----------------|
| Connector No.  | F23             |
| Connector Name | TCM             |
| Connector Type | RH40FB-R2E-L-RH |



| Terminal No. | Color Of Wire | Signal Name [Specification]            |
|--------------|---------------|--|
| 2            | GR            | L RANGE SW                             |
| 3            | GR            | RANGE SW                               |
| 4            | O             | RANGE SW                               |
| 5            | P/L           | R RANGE SW                             |
| 6            | P/B           | P RANGE SW                             |
| 7            | BR/W          | SENSOR GROUND                          |
| 11           | W/R           | CVT FLUID TEMPERATURE SENSOR           |
| 12           | V             | G SENSOR                               |
| 14           | W             | PRIMARY PRESSURE SENSOR                |
| 16           | V/W           | CAN-L                                  |
| 17           | LG            | SENSOR POWER                           |
| 23           | P             | INPUT SPEED SENSOR                     |
| 24           | BR            | SENSOR POWER                           |
| 28           | L/O           | LINE PRESSURE SOLENOID VALVE           |
| 30           | R/Y           | CAN-H                                  |
| 33           | L/R           | OUTPUT SPEED SENSOR                    |
| 34           | LG            | SELECT SOLENOID VALVE                  |
| 37           | L/W           | TORQUE CONVERTER CLUTCH SOLENOID VALVE |
| 38           | V/R           | SECONDARY PRESSURE SOLENOID VALVE      |
| 39           | W/B           | GROUND                                 |
| 40           | B/R           | GROUND                                 |
| 42           | B             | GROUND                                 |
| 45           | LG            | BATTERY POWER SUPPLY                   |
| 46           | LG            | BATTERY POWER SUPPLY                   |
| 47           | Y             | IGNITION POWER SUPPLY                  |
| 48           | Y             | IGNITION POWER SUPPLY                  |

|                |                     |
|----------------|---------------------|
| Connector No.  | M4                  |
| Connector Name | DATA LINK CONNECTOR |
| Connector Type | BD16FW              |

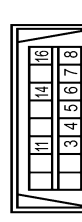

| Terminal No. | Color Of Wire | Signal Name [Specification] |
|--------------|---------------|-----------------------------|
| 3            | LG            | -                           |
| 4            | GR            | -                           |
| 5            | GR            | -                           |
| 6            | GR            | -                           |
| 7            | R             | -                           |
| 8            | G             | -                           |
| 11           | SB            | -                           |
| 14           | P             | -                           |
| 16           | P             | -                           |

|                |                  |
|----------------|------------------|
| Connector No.  | M6               |
| Connector Name | FUSE BLOCK (J/B) |
| Connector Type | CS06FW-M2        |

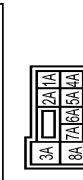

| Terminal No. | Color Of Wire | Signal Name [Specification] |
|--------------|---------------|-----------------------------|
| 1A           | Y             | -                           |
| 2A           | G             | -                           |
| 3A           | L             | -                           |
| 4A           | GR            | -                           |
| 5A           | R             | -                           |
| 6A           | B             | -                           |
| 7A           | GR            | -                           |
| 8A           | L             | -                           |



JRMWG3292GB

BCM (BODY CONTROL MODULE)

|                |                  |
|----------------|------------------|
| Connector No.  | M7               |
| Connector Name | FUSE BLOCK (J/B) |
| Connector Type | MSDFW-CS         |

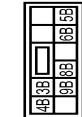

| Terminal No. | Color Of Wire | Signal Name [Specification] |
|--------------|---------------|-----------------------------|
| 4B           | W             | --                          |
| 5B           | W             | --                          |
| 6B           | BR            | --                          |
| 7B           | O             | --                          |
| 8B           | R/L           | --                          |
| 9B           | GR            | --                          |

|                |                  |
|----------------|------------------|
| Connector No.  | M8               |
| Connector Name | FUSE BLOCK (J/B) |
| Connector Type | MSDFW-CS         |

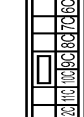

| Terminal No. | Color Of Wire | Signal Name [Specification] |
|--------------|---------------|-----------------------------|
| 10C          | LG            | --                          |
| 11C          | Y             | --                          |
| 12C          | Y             | --                          |
| 13C          | GR            | --                          |
| 14C          | GR            | --                          |
| 15C          | G             | --                          |
| 16C          | Y             | --                          |

|                |                |
|----------------|----------------|
| Connector No.  | M17            |
| Connector Name | OPTICAL SENSOR |
| Connector Type | TK03FW         |



| Terminal No. | Color Of Wire | Signal Name [Specification] |
|--------------|---------------|-----------------------------|
| 1            | P             | POWER                       |
| 2            | G             | CIRCUIT                     |
| 3            | R             | GROUND                      |

|                |                   |
|----------------|-------------------|
| Connector No.  | M26               |
| Connector Name | MATS ANTENNA AMP. |
| Connector Type | TK04FW-NH         |



| Terminal No. | Color Of Wire | Signal Name [Specification] |
|--------------|---------------|-----------------------------|
| 1            | Y             | BAT                         |
| 2            | GR            | CLK                         |
| 3            | P             | DATA                        |
| 4            | B             | GROUND                      |

|                |                   |
|----------------|-------------------|
| Connector No.  | M24               |
| Connector Name | COMBINATION METER |
| Connector Type | TK04FW-NH         |

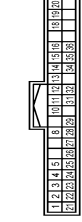

| Terminal No. | Color Of Wire | Signal Name [Specification]  |
|--------------|---------------|--|
| 1            | P             | BATTERY POWER SUPPLY (With automatic drive position)               |
| 2            | G             | IGNITION SIGNAL (Without automatic drive position)                 |
| 3            | Y             | IGNITION SIGNAL (With automatic drive position)                    |
| 4            | B             | GROUND   |
| 5            | B             | ILLUMINATION CONTROL SIGNAL (Without automatic drive position)     |
| 6            | B/P           | ILLUMINATION CONTROL SIGNAL (With automatic drive position)        |
| 8            | G             | TRIP RESET SWITCH SIGNAL (Without automatic drive position)        |
| 8            | SB            | TRIP RESET SWITCH SIGNAL (With automatic drive position)           |
| 10           | P             | METER CONTROL SWITCH GROUND  |
| 11           | G             | ENTER SWITCH SIGNAL  |
| 12           | BR            | SELECT SWITCH SIGNAL (With automatic drive position)               |
| 12           | R             | SELECT SWITCH SIGNAL (Without automatic drive position)            |
| 13           | Y             | ILLUMINATION CONTROL SIGNAL (Without automatic drive position)     |
| 13           | Y             | ILLUMINATION CONTROL SIGNAL (With automatic drive position)        |
| 14           | G             | ILLUMINATION CONTROL SIGNAL (Without automatic drive position)     |
| 14           | V             | ILLUMINATION CONTROL SIGNAL (With automatic drive position)        |
| 15           | BR            | AIR BAG SIGNAL   |
| 16           | L             | ENGINE COOLANT TEMPERATURE SIGNAL                                  |
| 18           | L             | AMBIENT SENSOR SIGNAL (Without automatic drive position)           |
| 18           | LG            | AMBIENT SENSOR SIGNAL (With automatic drive position)              |
| 19           | R             | A/C AUTO AMP. CONNECTION RECOGNITION SIGNAL                        |
| 20           | G             | AMBIENT SENSOR GROUND (Without automatic drive position)           |
| 20           | Y             | AMBIENT SENSOR GROUND (With automatic drive position)              |
| 21           | L             | CAN-H  |
| 22           | P             | CAN-L  |
| 23           | B             | GROUND   |
| 24           | B             | FUEL LEVEL SENSOR GROUND   |
| 25           | BR            | WASHER SIGNAL (Without automatic drive position)                   |
| 25           | W             | WASHER SIGNAL (With automatic drive position)                      |
| 26           | BR            | PARKING BRAKE SWITCH SIGNAL  |
| 27           | BE            | BRAKE FLUID LEVEL SWITCH SIGNAL (Without automatic drive position) |
| 27           | Y             | BRAKE FLUID LEVEL SWITCH SIGNAL (With automatic drive position)    |
| 28           | V             | SECURITY SIGNAL  |
| 29           | G             | WASHER LEVEL SWITCH SIGNAL   |

|    |    |  |
|----|----|--|
| 31 | SB | VEHICLE SPEED SIGNAL (R-PULSE)                   |
| 32 | BR | OVERRIDE CONTROL SWITCH SIGNAL                   |
| 34 | O  | FUEL LEVEL SENSOR SIGNAL                         |
| 35 | BR | WASHER SIGNAL (Without automatic drive position) |
| 35 | P  | WASHER SIGNAL (With automatic drive position)    |
| 36 | BR | PASSENGER SEAT BELT WARNING SIGNAL               |

|                |             |
|----------------|-------------|
| Connector No.  | M40         |
| Connector Name | DIODE       |
| Connector Type | 24335 09802 |



| Terminal No. | Color Of Wire | Signal Name [Specification] |
|--------------|---------------|-----------------------------|
| 1            | B             | --                          |
| 2            | B             | --                          |

|                |               |
|----------------|---------------|
| Connector No.  | M45           |
| Connector Name | HAZARD SWITCH |
| Connector Type | TK04FW        |



| Terminal No. | Color Of Wire | Signal Name [Specification] |
|--------------|---------------|-----------------------------|
| 1            | B             | --                          |
| 2            | R             | --                          |
| 3            | R             | --                          |
| 4            | B             | --                          |

A  
B  
C  
D  
E  
F  
G  
H  
I  
J  
K  
L  
N  
O  
P

BCM (BODY CONTROL MODULE)

|                |           |
|----------------|-----------|
| Connector No.  | M89       |
| Connector Name | A/C AMP.  |
| Connector Type | TH40FW-NH |

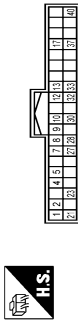

|                |           |
|----------------|-----------|
| Connector No.  | M89       |
| Connector Name | A/C AMP.  |
| Connector Type | TH40FW-NH |



| Terminal No. | Color Of Wire | Signal Name [Specification]                  |
|--------------|---------------|--|
| 1            | P             | BATTERY POWER SUPPLY                         |
| 2            | G             | IGNITION LOCK POWER SUPPLY                   |
| 3            | SB            | DOOR MOTOR POWER SUPPLY                      |
| 4            | SB            | DOOR MOTOR POWER SUPPLY                      |
| 5            | BR            | LAN SIGNAL                                   |
| 6            | R             | REAR WINDOW DEFOGGER F/B SIGNAL              |
| 7            | R             | REAR WINDOW DEFOGGER F/B SIGNAL              |
| 8            | P             | ILLUMINATION POWER SUPPLY                    |
| 9            | GR            | ACC POWER SUPPLY                             |
| 10           | W             | FRONT BLOWER MOTOR CONTROL SIGNAL            |
| 12           | BE            | BLOWER FAN ON SIGNAL                         |
| 13           | G             | A/C ON SIGNAL                                |
| 17           | G             | ENGINE COOLANT TEMPERATURE SIGNAL            |
| 21           | B             | GROUND                                       |
| 23           | B             | GROUND                                       |
| 27           | BE            | REAR WINDOW DEFOGGER ON SIGNAL               |
| 28           | GR            | ILLUMINATION GROUND                          |
| 32           | G             | COMM (A/C AUTO AMP->RR A/C CONT)             |
| 33           | W             | COMM (RR A/C CONT->A/C AUTO AMP)             |
| 36           | R             | EPH GAS/OUTSIDE DOOR DETECTING SENSOR SIGNAL |
| 37           | BE            | INTAKE SENSOR SIGNAL                         |
| 38           | GR            | REAR IN-VEHICLE SENSOR SIGNAL                |
| 39           | L             | AMBIENT SENSOR SIGNAL                        |
| 40           | G             | SENSOR GROUND                                |

| Terminal No. | Color Of Wire | Signal Name [Specification]                  |
|--------------|---------------|--|
| 1            | P             | BATTERY POWER SUPPLY                         |
| 2            | G             | IGNITION LOCK POWER SUPPLY                   |
| 3            | SB            | DOOR MOTOR POWER SUPPLY                      |
| 4            | SB            | DOOR MOTOR POWER SUPPLY                      |
| 5            | BR            | LAN SIGNAL                                   |
| 6            | R             | REAR WINDOW DEFOGGER F/B SIGNAL              |
| 7            | R             | REAR WINDOW DEFOGGER F/B SIGNAL              |
| 8            | P             | ILLUMINATION POWER SUPPLY                    |
| 9            | GR            | ACC POWER SUPPLY                             |
| 10           | W             | FRONT BLOWER MOTOR CONTROL SIGNAL            |
| 12           | BE            | BLOWER FAN ON SIGNAL                         |
| 13           | G             | A/C ON SIGNAL                                |
| 15           | GR            | IONIZER ON/OFF CONTROL SIGNAL                |
| 17           | G             | ENGINE COOLANT TEMPERATURE SIGNAL            |
| 18           | W             | SINUSOID SENSOR SIGNAL                       |
| 19           | P             | FRONT IN-VEHICLE SENSOR SIGNAL               |
| 20           | R             | A/C AUTO AMP CONNECTION RECOGNITION SIGNAL   |
| 21           | B             | GROUND                                       |
| 23           | B             | GROUND                                       |
| 24           | BE            | VEHICLE SPEED SIGNAL                         |
| 27           | BE            | REAR WINDOW DEFOGGER ON SIGNAL               |
| 28           | GR            | ILLUMINATION GROUND                          |
| 30           | R             | REAR BLOWER MOTOR CONTROL SIGNAL             |
| 32           | G             | COMM (A/C AUTO AMP->RR A/C CONT)             |
| 33           | W             | COMM (RR A/C CONT->A/C AUTO AMP)             |
| 36           | R             | EPH GAS/OUTSIDE DOOR DETECTING SENSOR SIGNAL |
| 37           | BE            | INTAKE SENSOR SIGNAL                         |
| 38           | GR            | REAR IN-VEHICLE SENSOR SIGNAL                |
| 39           | L             | AMBIENT SENSOR SIGNAL                        |
| 40           | G             | SENSOR GROUND                                |

|                |                    |
|----------------|--------------------|
| Connector No.  | M87                |
| Connector Name | CVT SHIFT SELECTOR |
| Connector Type | TH12PW-NH          |

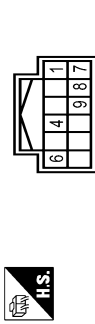

| Terminal No. | Color Of Wire | Signal Name [Specification] |
|--------------|---------------|-----------------------------|
| 1            | P             | -                           |
| 2            | P             | -                           |
| 3            | W             | -                           |
| 4            | W             | -                           |
| 5            | W             | -                           |
| 6            | W             | -                           |
| 7            | B             | -                           |
| 8            | BE            | -                           |
| 9            | G             | -                           |

|                |                               |
|----------------|-------------------------------|
| Connector No.  | M89                           |
| Connector Name | AIR BAG DIAGNOSIS SENSOR UNIT |
| Connector Type | NH28FY-EX                     |

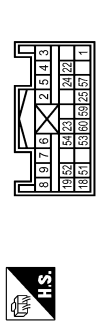

| Terminal No. | Color Of Wire | Signal Name [Specification] |
|--------------|---------------|-----------------------------|
| 1            | BE            | IGN                         |
| 2            | GR            | GROUND                      |
| 3            | LG            | DR1 (+)                     |
| 4            | Y             | DR1 (-) DR2 (-)             |
| 5            | V             | DR 2 (+)                    |
| 6            | V             | ASI (+)                     |
| 7            | LG            | ASI (-)                     |
| 8            | YL            | AS 2 (-)                    |
| 9            | YL            | AS 2 (-)                    |
| 18           | B             | EGZS (-)                    |
| 19           | W             | EGZS (-)                    |
| 22           | GR            | GROUND                      |
| 23           | R             | AIRBAG W/L                  |
| 24           | LG            | SEATBELT W/L                |

|    |    |                               |
|----|----|-------------------------------|
| 25 | LG | OUTSIDE REAR TAIL             |
| 51 | W  | TRIP RESET                    |
| 52 | W  | SIDE SENS LH2                 |
| 53 | W  | SIDE SENS LH2                 |
| 54 | B  | SIDE SENS LH2                 |
| 57 | W  | SIDE SENS LH2                 |
| 59 | L  | DEPLOYMENT INFORMATION OUTPUT |
| 60 | P  | CAN-H                         |
|    |    | CAN-L                         |

|                |                        |
|----------------|------------------------|
| Connector No.  | M81                    |
| Connector Name | SELECTIVE UNLOCK RELAY |
| Connector Type | MS08FF-M2-LC           |

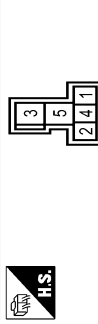

| Terminal No. | Color Of Wire | Signal Name [Specification] |
|--------------|---------------|-----------------------------|
| 1            | P             | -                           |
| 2            | P             | -                           |
| 3            | W             | -                           |
| 4            | B             | -                           |
| 5            | P             | -                           |

|                |                             |
|----------------|-----------------------------|
| Connector No.  | M101                        |
| Connector Name | PUSH-BUTTON IGNITION SWITCH |
| Connector Type | TK08FR                      |

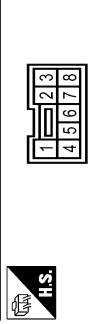

| Terminal No. | Color Of Wire | Signal Name [Specification] |
|--------------|---------------|-----------------------------|
| 1            | B             | -                           |
| 2            | B             | -                           |
| 3            | P             | -                           |
| 4            | V             | -                           |
| 5            | W             | -                           |

JRMWG3294GB



BCM (BODY CONTROL MODULE)

| Terminal No. | Color Of Wire | Signal Name [Specification] |
|--------------|---------------|-----------------------------|
| 9            | R             | -                           |
| 10           | G             | -                           |
| 11           | W             | -                           |

|                |                    |
|----------------|--------------------|
| Connector No.  | M103               |
| Connector Name | COMBINATION SWITCH |
| Connector Type | TH18FW-NH          |

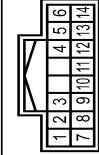

| Terminal No. | Color Of Wire | Signal Name [Specification] |
|--------------|---------------|-----------------------------|
| 1            | GR            | -                           |
| 2            | B             | -                           |

|                |                           |
|----------------|---------------------------|
| Connector No.  | M121                      |
| Connector Name | BCM (BODY CONTROL MODULE) |
| Connector Type | TH40FB-NH                 |

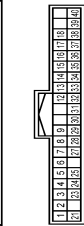

| Terminal No. | Color Of Wire | Signal Name [Specification]      |
|--------------|---------------|----------------------------------|
| 1            | R             | RR                               |
| 2            | G             | OUTPUT 4                         |
| 3            | P             | FR                               |
| 4            | W             | IGN                              |
| 5            | BE            | OUTPUT 3                         |
| 6            | B/Y           | GROUND                           |
| 7            | P             | INPUT 3                          |
| 8            | R             | OUTPUT 5                         |
| 9            | GR            | INPUT 2                          |
| 10           | W             | REAR WIPER (WITH ANTENNA A/G)    |
| 11           | W             | REAR WIPER (WITHOUT ANTENNA A/G) |
| 12           | W             | OUTPUT 4                         |
| 13           | R             | INPUT 5                          |
| 14           | G             | OUTPUT 2                         |

|                |  |
|----------------|--|
| Connector No.  | M105                                   |
| Connector Name | INSIDE KEY ANTENNA (INSTRUMENT CENTER) |
| Connector Type | IR03FL                                 |



| Terminal No. | Color Of Wire | Signal Name [Specification] |
|--------------|---------------|-----------------------------|
| 36           | R             | COMBI SW OUTPUT 1           |
| 37           | G             | DR DET SW                   |
| 38           | BE            | RECEIVER COMM               |
| 39           | L             | CAN-H                       |
| 40           | P             | CAN-L                       |

|                |                           |
|----------------|---------------------------|
| Connector No.  | M122                      |
| Connector Name | BCM (BODY CONTROL MODULE) |
| Connector Type | FEA09FB-FHA6-SA           |

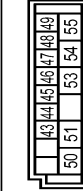

| Terminal No. | Color Of Wire | Signal Name [Specification] |
|--------------|---------------|-----------------------------|
| 43           | P             | REAR WIPER STOP POSITION    |
| 44           | GR            | BK DOOR SW                  |
| 45           | W             | PASS DOOR SW                |
| 46           | R             | SL DOOR RH SW               |
| 47           | G             | DR DOOR SW                  |
| 48           | BE            | SL DOOR LH SW               |
| 49           | B             | Luggage Lamp CONT           |
| 50           | G             | SEATBELT LOCK CONT          |
| 51           | G             | BK DOOR REG SW              |
| 53           | BR            | BK DOOR OPEN                |
| 54           | R             | REAR WIPER OUTPUT           |
| 55           | G             | SL DOOR LH UNLK CONT        |

|                |                           |
|----------------|---------------------------|
| Connector No.  | M123                      |
| Connector Name | BCM (BODY CONTROL MODULE) |
| Connector Type | FEA09FW-FHA6-SA           |

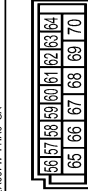

| Terminal No. | Color Of Wire | Signal Name [Specification] |
|--------------|---------------|-----------------------------|
| 56           | P             | INT ROOM LAMP PWR SPLY      |
| 57           | Y             | BAT                         |
| 58           | O             | AIR BAG                     |
| 59           | SB            | PASS DOOR UNLK OUTPUT       |
| 60           | V             | TURN SIG LH OUTPUT          |
| 61           | G             | TURN SIG RH OUTPUT          |
| 62           | W             | STEP LAMP CONT              |
| 63           | R             | INT ROOM LAMP CONT          |
| 64           | W             | CRANK REQ                   |
| 65           | V             | ALL DOOR LOCK OUTPUT        |
| 66           | G             | DR DOOR UNLK OUTPUT         |
| 67           | B             | GROUND                      |
| 68           | W             | PWR PWR SW (IGN)            |
| 69           | P             | PWR PWR SW (BAT)            |
| 70           | L             | BAT                         |

|                |                           |
|----------------|---------------------------|
| Connector No.  | M124                      |
| Connector Name | BCM (BODY CONTROL MODULE) |
| Connector Type | TH40FW-NH                 |



| Terminal No. | Color Of Wire | Signal Name [Specification]  |
|--------------|---------------|------------------------------|
| 73           | G             | ON IND                       |
| 75           | G             | DR DOOR REG SW               |
| 76           | V             | PUSH SW                      |
| 78           | B             | DR DOOR ANT+                 |
| 79           | W             | DR DOOR ANT-                 |
| 80           | GR            | PASS DOOR ANT+               |
| 81           | BE            | PASS DOOR ANT-               |
| 82           | G             | REAR EMER ANT+               |
| 83           | R             | REAR EMER ANT-               |
| 84           | GR            | ROOM ANT+                    |
| 85           | W             | ROOM ANT-                    |
| 86           | BE            | ROOM ANT2-                   |
| 88           | GR            | Luggage Room ANT+            |
| 89           | B             | Luggage Room ANT-            |
| 90           | P             | PUSH-BTN IGN SW ILL PWR SPLY |
| 91           | W             | LOCK IND                     |



BCM (BODY CONTROL MODULE)

|     |    |                             |
|-----|----|-----------------------------|
| 82  | B  | PUSH-BTN IGN SW L/GND       |
| 83  | BE | IGN SW L/GND                |
| 84  | BE | ACC RELAY CONTROL           |
| 87  | W  | STARTER RELAY COM1          |
| 88  | P  | IGN RELAY (BDM E/R) CONT    |
| 89  | G  | IGN RELAY (F/B) CONT OUTPUT |
| 100 | R  | PASS DOOR REQ SW            |
| 101 | R  | IGN PWR SPLY 2              |
| 102 | P  | P/N POSITION                |
| 104 | L  | CVT SHIFT SELECT PWR SPLY   |
| 105 | R  | STOP LAMP SW 2              |
| 106 | O  | BLWR RELAY CONT OUTPUT      |
| 109 | R  | ACC IND                     |

|                |             |
|----------------|-------------|
| Connector No.  | M130        |
| Connector Name | DONGLE UNIT |
| Connector Type | NS2BBER-GS  |

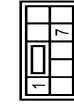

|              |               |                             |
|--------------|---------------|-----------------------------|
| Terminal No. | Color Of Wire | Signal Name [Specification] |
| 7            | B             | GROUND                      |
| 7            | B             | INTERFAGE                   |

|                |                 |
|----------------|-----------------|
| Connector No.  | M183            |
| Connector Name | AV CONTROL UNIT |
| Connector Type | NH18FW-CSZ      |

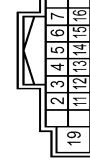

|              |               |  |
|--------------|---------------|--|
| Terminal No. | Color Of Wire | Signal Name [Specification]            |
| 2            | LG            | SOUND SIGNAL FRONT SPEAKER LH (+)      |
| 3            | Y             | SOUND SIGNAL FRONT SPEAKER LH (-)      |
| 4            | V             | SOUND SIGNAL SLIDE DOOR SPEAKER LH (+) |

|    |    |  |
|----|----|--|
| 5  | L  | SOUND SIGNAL SLIDE DOOR SPEAKER LH (-) |
| 6  | BE | STRG SW A                              |
| 7  | G  | STRG SW B                              |
| 8  | BE | MR OUTPUT                              |
| 11 | L  | SOUND SIGNAL FRONT SPEAKER RH (+)      |
| 12 | B  | SOUND SIGNAL FRONT SPEAKER RH (-)      |
| 13 | BR | SOUND SIGNAL SLIDE DOOR SPEAKER RH (+) |
| 14 | SB | SOUND SIGNAL SLIDE DOOR SPEAKER RH (-) |
| 15 | W  | STRG SW GND                            |
| 16 | P  | STRG SW B                              |
| 19 | SB | BATTERY                                |
| 20 | B  | GROUND                                 |

|                |                 |
|----------------|-----------------|
| Connector No.  | M186            |
| Connector Name | AV CONTROL UNIT |
| Connector Type | TH32FW-NH       |

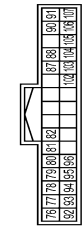

|              |               |                                |
|--------------|---------------|--------------------------------|
| Terminal No. | Color Of Wire | Signal Name [Specification]    |
| 75           | LG            | AV COMM (L)                    |
| 76           | LG            | AV COMM (L)                    |
| 78           | SB            | AV COMM (R)                    |
| 80           | P             | CAN-L                          |
| 81           | L             | CAN-H                          |
| 82           | R             | SW GND                         |
| 87           | R             | SOUND SIGNAL (-)               |
| 88           | W             | SOUND SIGNAL (+)               |
| 90           | BR            | HEADPHONE SOUND SIGNAL RH (+)  |
| 91           | Y             | HEADPHONE SOUND SIGNAL RH (-)  |
| 92           | P             | VEHICLE SPEED SIGNAL (8-PULSE) |
| 93           | R             | PARKING BRAKE                  |
| 94           | W             | REVERSE                        |
| 95           | G             | IGNITION                       |
| 96           | W             | DISK ESTOP SIGNAL              |
| 102          | W             | AUX SOUND SIGNAL LH (+)        |
| 103          | B             | AUX SOUND SIGNAL LH (-)        |
| 104          | R             | AUX SOUND SIGNAL RH (+)        |
| 105          | GR            | SHIELD                         |
| 106          | P             | HEADPHONE SOUND SIGNAL LH (+)  |
| 107          | L             | HEADPHONE SOUND SIGNAL LH (-)  |

|                |                 |
|----------------|-----------------|
| Connector No.  | M189            |
| Connector Name | AV CONTROL UNIT |
| Connector Type | TH32FW-NH       |

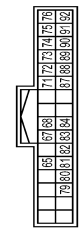

|              |               |                                |
|--------------|---------------|--------------------------------|
| Terminal No. | Color Of Wire | Signal Name [Specification]    |
| 85           | R             | PARKING BRAKE                  |
| 86           | R             | COMPOSITE IMAGE GND            |
| 88           | R             | COMPOSITE IMAGE SIGNAL         |
| 71           | SHIELD        | SHIELD                         |
| 72           | W             | MICROPHONE VCC                 |
| 73           | B             | COMM (CONT->DISP)              |
| 74           | P             | CAN-L                          |
| 75           | LG            | AV COMM (L)                    |
| 76           | LG            | AV COMM (L)                    |
| 79           | BE            | MR OUTPUT                      |
| 80           | G             | IGNITION                       |
| 81           | W             | REVERSE                        |
| 82           | P             | VEHICLE SPEED SIGNAL (8-PULSE) |
| 83           | SHIELD        | SHIELD                         |
| 84           | B             | COMPOSITE IMAGE SYNC           |
| 87           | B             | MICROPHONE SIGNAL              |
| 88           | SHIELD        | SHIELD                         |
| 89           | W             | COMM (DISP->CONT)              |
| 90           | L             | CAN-H                          |
| 91           | SB            | AV COMM (H)                    |
| 92           | V             | AV COMM (H)                    |

|                |                       |
|----------------|-----------------------|
| Connector No.  | R10                   |
| Connector Name | VANITY MIRROR LAMP RH |
| Connector Type | MC402FW               |



|              |               |                             |
|--------------|---------------|-----------------------------|
| Terminal No. | Color Of Wire | Signal Name [Specification] |
| 1            | P             | -                           |
| 2            | B             | -                           |

|                |                         |
|----------------|-------------------------|
| Connector No.  | R17                     |
| Connector Name | SECOND PERSONAL LAMP RH |
| Connector Type | TR03FW                  |



|              |               |                             |
|--------------|---------------|-----------------------------|
| Terminal No. | Color Of Wire | Signal Name [Specification] |
| 1            | P             | -                           |
| 2            | O             | -                           |
| 3            | B             | -                           |

A  
B  
C  
D  
E  
F  
G  
H  
I  
J  
K  
L  
N  
O  
P



BCM (BODY CONTROL MODULE)

|                |                         |
|----------------|-------------------------|
| Connector No.  | R18                     |
| Connector Name | SECOND PERSONAL LAMP LH |
| Connector Type | TK03FW                  |



| Terminal No. | Color Of Wire | Signal Name [Specification] |
|--------------|---------------|-----------------------------|
| 1            | P             | --                          |
| 2            | O             | --                          |
| 3            | B             | --                          |

|                |                       |
|----------------|-----------------------|
| Connector No.  | R24                   |
| Connector Name | VANITY MIRROR LAMP LH |
| Connector Type | MCAM02FW              |



| Terminal No. | Color Of Wire | Signal Name [Specification] |
|--------------|---------------|-----------------------------|
| 1            | P             | --                          |
| 2            | B             | --                          |

|                |                        |
|----------------|------------------------|
| Connector No.  | R27                    |
| Connector Name | THIRD PERSONAL LAMP RH |
| Connector Type | TK03FW                 |



| Terminal No. | Color Of Wire | Signal Name [Specification] |
|--------------|---------------|-----------------------------|
| 1            | O             | --                          |
| 2            | O             | --                          |
| 3            | B             | --                          |

|                |                        |
|----------------|------------------------|
| Connector No.  | R28                    |
| Connector Name | THIRD PERSONAL LAMP LH |
| Connector Type | TK03FW                 |



| Terminal No. | Color Of Wire | Signal Name [Specification] |
|--------------|---------------|-----------------------------|
| 1            | P             | --                          |
| 2            | O             | --                          |
| 3            | B             | --                          |

|                |                              |
|----------------|------------------------------|
| Connector No.  | R31                          |
| Connector Name | FRONT SUNROOF MOTOR ASSEMBLY |
| Connector Type | YEA10FGY                     |



| Terminal No. | Color Of Wire | Signal Name [Specification] |
|--------------|---------------|-----------------------------|
| 1            | V             | GROUND                      |
| 3            | V             | IGN/TIMER                   |
| 5            | LS            | OPENSWMT-O                  |
| 6            | L             | BAT                         |
| 8            | Y             | VEHICLE SPEED (8-PULSE)     |
| 10           | V             | CLOSESWMT-1                 |

|                |                             |
|----------------|-----------------------------|
| Connector No.  | R32                         |
| Connector Name | REAR SUNROOF MOTOR ASSEMBLY |
| Connector Type | YEA10FGY                    |



| Terminal No. | Color Of Wire | Signal Name [Specification] |
|--------------|---------------|-----------------------------|
| 1            | B             | GROUND                      |
| 3            | V             | IGN/TIMER                   |
| 5            | BR            | OPEN SWMAP                  |
| 6            | L             | BAT                         |
| 7            | SB            | COM                         |
| 8            | SB            | VEHICLE SPEED (8-PULSE)     |
| 10           | SB            | CLOSE SWMAP                 |

|                |                               |
|----------------|-------------------------------|
| Connector No.  | R108                          |
| Connector Name | REMOTE KEYLESS ENTRY RECEIVER |
| Connector Type | TH04FW-NH                     |



| Terminal No. | Color Of Wire | Signal Name [Specification] |
|--------------|---------------|-----------------------------|
| 1            | BR            | BAT                         |
| 2            | BR            | SIGNAL                      |
| 4            | LG            | GROUND                      |

|                |          |
|----------------|----------|
| Connector No.  | R109     |
| Connector Name | MAP LAMP |
| Connector Type | TK08FGY  |



| Terminal No. | Color Of Wire | Signal Name [Specification] |
|--------------|---------------|-----------------------------|
| 1            | Y             | --                          |
| 2            | V             | --                          |
| 3            | L             | --                          |
| 4            | B             | --                          |
| 5            | BR            | --                          |
| 6            | SB            | --                          |

JRMWG3297GB

# INSPECTION AND ADJUSTMENT

< BASIC INSPECTION >

## BASIC INSPECTION

### INSPECTION AND ADJUSTMENT

#### ADDITIONAL SERVICE WHEN REPLACING CONTROL UNIT (BCM)

#### ADDITIONAL SERVICE WHEN REPLACING CONTROL UNIT (BCM) : Description

INFOID:000000011324336

##### BEFORE REPLACEMENT

When replacing BCM, save or print current vehicle specification with CONSULT configuration before replacement.

##### NOTE:

If "READ CONFIGURATION" can not be used, use the "WRITE CONFIGURATION - Manual selection" after replacing BCM.

##### AFTER REPLACEMENT

##### CAUTION:

When replacing BCM, always perform "WRITE CONFIGURATION" with CONSULT. Or not doing so, BCM control function does not operate normally.

- Complete the procedure of "WRITE CONFIGURATION" in order.
- Configuration is different for each vehicle model. Confirm configuration of each vehicle model.
- If you set incorrect "WRITE CONFIGURATION", incidents might occur.

##### NOTE:

When replacing BCM, perform the system initialization (NATS) (if equipped).

#### ADDITIONAL SERVICE WHEN REPLACING CONTROL UNIT (BCM) : Work Procedure

INFOID:000000011324337

#### 1. SAVING VEHICLE SPECIFICATION

##### CONSULT Configuration

Perform "READ CONFIGURATION" to save or print current vehicle specification. Refer to [BCS-84, "CONFIGURATION \(BCM\) : Description"](#).

##### NOTE:

If "READ CONFIGURATION" can not be used, use the "WRITE CONFIGURATION - Manual selection" after replacing BCM.

>> GO TO 2.

#### 2. REPLACE BCM

Replace BCM. Refer to [BCS-98, "Removal and Installation"](#).

>> GO TO 3.

#### 3. WRITING VEHICLE SPECIFICATION

##### CONSULT Configuration

Perform "WRITE CONFIGURATION - Config file" or "WRITE CONFIGURATION - Manual selection" to write vehicle specification. Refer to [BCS-84, "CONFIGURATION \(BCM\) : Work Procedure"](#).

>> GO TO 4.

#### 4. INITIALIZE BCM (NATS) (IF EQUIPPED)

Perform BCM initialization. (NATS)

>> WORK END

#### CONFIGURATION (BCM)

A  
B  
C  
D  
E  
F  
G  
H  
I  
J  
K  
L

BCS

N  
O  
P

# INSPECTION AND ADJUSTMENT

< BASIC INSPECTION >

## CONFIGURATION (BCM) : Description

INFOID:000000011324338

Vehicle specification needs to be written with CONSULT because it is not written after replacing BCM. Configuration has three functions as follows.

| Function                               | Description   |
|--|---|
| READ CONFIGURATION                     | <ul style="list-style-type: none"><li>• Reads the vehicle configuration of current BCM.</li><li>• Saves the read vehicle configuration.</li></ul> |
| WRITE CONFIGURATION - Manual selection | Writes the vehicle configuration with manual selection.   |
| WRITE CONFIGURATION - Config file      | Writes the vehicle configuration with saved data.   |

### NOTE:

Manual setting item: Items which need selection by vehicle specifications

Automatic setting item: Items which are written in automatically (Setting can not be changed)

For some models and specifications, the automatic setting item may not be displayed.

### CAUTION:

**When replacing BCM, always perform "WRITE CONFIGURATION" with CONSULT. Or not doing so, BCM control function does not operate normally.**

- Complete the procedure of "WRITE CONFIGURATION" in order.
- Configuration is different for each vehicle model. Confirm configuration of each vehicle model.
- Never perform "WRITE CONFIGURATION" except for new BCM.
- If you set incorrect "WRITE CONFIGURATION", incidents might occur.

## CONFIGURATION (BCM) : Work Procedure

INFOID:000000011324339

### 1. WRITING MODE SELECTION

 CONSULT Configuration  
Select "CONFIGURATION" of BCM.

When writing saved data >> GO TO 2.

When writing manually >> GO TO 3.

### 2. PERFORM "WRITE CONFIGURATION - CONFIG FILE"

 CONSULT Configuration  
Perform "WRITE CONFIGURATION - Config file".

>> WORK END

### 3. PERFORM "WRITE CONFIGURATION - MANUAL SELECTION"

-  CONSULT Configuration
1. Select "WRITE CONFIGURATION - Manual selection".
  2. Identify the correct model and configuration list. Refer to [BCS-85. "CONFIGURATION \(BCM\) : Configuration list"](#).
  3. Confirm and/or change setting value for each item.  
**CAUTION:**  
**Thoroughly read and understand the vehicle specification. ECU control may not operate normally if the setting is not correct.**  
**NOTE:**  
If items are not displayed, touch "SETTING". Refer to [BCS-85. "CONFIGURATION \(BCM\) : Configuration list"](#) for written items and setting value.
  4. Select "SETTING".  
**CAUTION:**  
**Make sure to select "SETTING" even if the indicated configuration of brand new BCM is same as the desirable configuration. If not, configuration which is set automatically by selecting vehicle model can not be memorized.**
  5. When "COMMAND FINISHED", select "END".

>> GO TO 4.

# INSPECTION AND ADJUSTMENT

< BASIC INSPECTION >

## 4. OPERATION CHECK

Confirm that each function controlled by BCM operates normally.

>> WORK END

### CONFIGURATION (BCM) : Configuration list

INFOID:000000011324340

#### **CAUTION:**

**Thoroughly read and understand the vehicle specification. ECU control may not operate normally if the setting is not correct.**

| SETTING ITEM        |                           | NOTE   |
|---------------------|---------------------------|--|
| Items               | Setting value             |  |
| CAN CONNECTION UNIT | WITHOUT ⇔ MODE13 ⇔ MODE15 | <ul style="list-style-type: none"><li>• WITHOUT: Without automatic sliding door system and automatic back door system</li><li>• MODE13: With automatic sliding door system and automatic back door system</li><li>• MODE15: With automatic sliding door system, and without automatic back door system</li></ul> |
| AUTO LIGHT          | WITH ⇔ WITHOUT            | —  |
| DTRL                | WITH ⇔ WITHOUT            | <ul style="list-style-type: none"><li>• WITH: With daytime running light system</li><li>• WITHOUT: Without daytime running light system</li></ul>  |

⇔: Items which confirm vehicle specifications

A  
B  
C  
D  
E  
F  
G  
H  
I  
J  
K  
L

BCS

N  
O  
P

# SHIPPING MODE CANCEL OPERATION

< BASIC INSPECTION >

## SHIPPING MODE CANCEL OPERATION

### Description

INFOID:000000011324341

### SYSTEM DIAGRAM

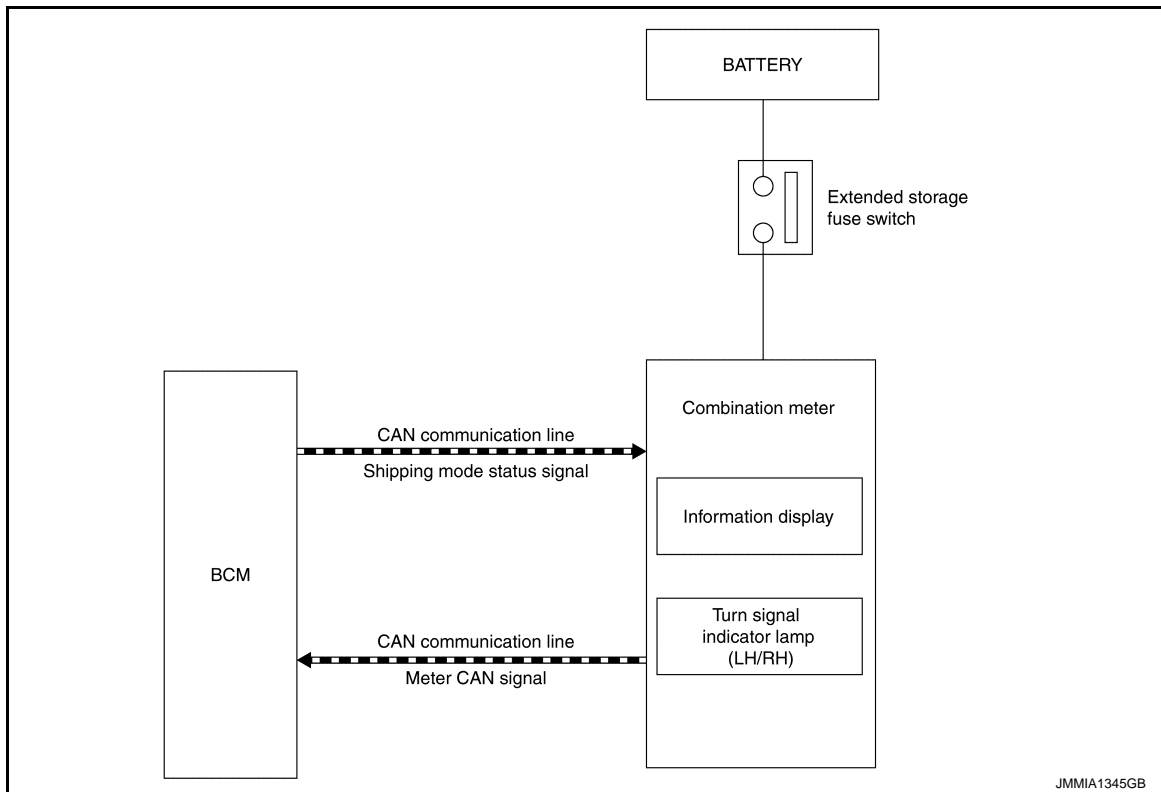

### DESCRIPTION

- The combination meter transmits meter CAN signal\*<sup>1</sup> to BCM via CAN communication, when the extended storage fuse switch is ON.
- BCM switches the status (shipping mode or normal mode) by itself according to the meter CAN signal\*<sup>1</sup> from combination meter, and transmits shipping mode status signal to combination meter via CAN communication.
- The combination meter displays extended storage fuse warning message\*<sup>2</sup> on the information display, and turns the turn signal indicator lamp (LH/RH) ON, when BCM is in shipping mode.
- BCM control functions are limited in shipping mode. Refer to [BCS-97. "Description"](#).

\*1: Odometer signal, wake up signal and each signal.

\*2: When shipping mode function operates, "SHIPPING MODE ON PUSH STORAGE FUSE" is displayed.

### Work Procedure

INFOID:000000011324342

#### 1. SHIPPING MODE CANCEL OPERATION

1. Turn ignition switch OFF.
2. Push in (switch on) the extended storage fuse switch. Refer to [PG-113. "How To Check"](#).
3. Turn ignition switch ON.
4. Turn ignition switch OFF and wait at least 2 seconds.

>> GO TO 2.

#### 2. SHIPPING MODE CANCEL CHECK

1. Turn ignition switch ON.
2. Check that extended storage fuse warning message is not displayed on odometer display.

>> WORK END

# U1000 CAN COMM

< DTC/CIRCUIT DIAGNOSIS >

## DTC/CIRCUIT DIAGNOSIS

### U1000 CAN COMM

#### Description

INFOID:0000000011324343

CAN (Controller Area Network) is a serial communication line for real time applications. It is an on-vehicle multiplex communication line with high data communication speed and excellent error detection ability. Modern vehicle is equipped with many electronic control unit, and each control unit shares information and links with other control units during operation (not independent). In CAN communication, control units are connected with 2 communication lines (CAN H-line, CAN L-line) allowing a high rate of information transmission with less wiring. Each control unit transmits/receives data but selectively reads required data only.

CAN Communication Signal Chart. Refer to [LAN-32, "CAN COMMUNICATION SYSTEM : CAN Communication Signal Chart"](#).

#### DTC Logic

INFOID:0000000011324344

#### DTC DETECTION LOGIC

| DTC   | CONSULT display description | DTC Detection Condition  | Possible cause           |
|-------|-----------------------------|--|--------------------------|
| U1000 | CAN COMM                    | When BCM cannot communicate CAN communication signal continuously for 2 seconds or more. | CAN communication system |

#### Diagnosis Procedure

INFOID:0000000011324345

#### 1. PERFORM SELF DIAGNOSTIC

1. Turn ignition switch ON and wait for 2 seconds or more.
2. Check "Self Diagnostic Result" of BCM.

#### Is DTC "U1000" displayed?

- YES >> Refer to [LAN-17, "Trouble Diagnosis Flow Chart"](#).  
NO >> Refer to [GI-42, "Intermittent Incident"](#).

A  
B  
C  
D  
E  
F  
G  
H  
I  
J  
K  
L

BCS

N  
O  
P

## U1010 CONTROL UNIT (CAN)

< DTC/CIRCUIT DIAGNOSIS >

### U1010 CONTROL UNIT (CAN)

#### DTC Logic

INFOID:000000011324346

#### DTC DETECTION LOGIC

| DTC   | CONSULT display de-<br>scription | DTC Detection Condition                                      | Possible cause |
|-------|----------------------------------|--|----------------|
| U1010 | CONTROL UNIT (CAN)               | BCM detected internal CAN communication circuit malfunction. | BCM            |

#### Diagnosis Procedure

INFOID:000000011324347

#### 1. REPLACE BCM

When DTC "U1010" is detected, replace BCM.

>> Replace BCM. Refer to [BCS-98. "Removal and Installation"](#).



# U0415 VEHICLE SPEED

< DTC/CIRCUIT DIAGNOSIS >

## U0415 VEHICLE SPEED

### Description

INFOID:0000000011324348

U0415 is displayed if any unusual condition is present in the reception status of the vehicle speed signal from the ABS actuator and electric unit (control unit).

### DTC Logic

INFOID:0000000011324349

### DTC DETECTION LOGIC

| DTC   | CONSULT display description | DTC Detection Condition   | Probable cause  |
|-------|-----------------------------|---|---|
| U0415 | VEHICLE SPEED               | When the vehicle speed signal received from the ABS actuator and electric unit (control unit) remains abnormal for 2 seconds or more. | <ul style="list-style-type: none"><li>• ABS actuator and electric unit (control unit)</li><li>• BCM</li></ul> |

### DTC CONFIRMATION PROCEDURE

#### 1. DTC CONFIRMATION

1. Erase the DTC.
2. Turn ignition switch OFF.
3. Perform the "Self Diagnostic Result" of BCM with CONSULT, when passed 2 seconds or more after the ignition switch is turned ON.

#### Is any DTC detected?

- YES >> Refer to [BCS-89, "Diagnosis Procedure"](#).  
NO >> INSPECTION END

### Diagnosis Procedure

INFOID:0000000011324350

#### 1. ABS ACTUATOR AND ELECTRIC UNIT (CONTROL UNIT) SELF-DIAG RESULTS

Perform "Self-Diagnostic Result" of ABS actuator and electric unit (control unit) with CONSULT. Refer to [BRC-38, "DTC Index"](#).

#### Is any DTC detected?

- YES >> Repair or replace the malfunctioning part.  
NO >> Replace BCM. Refer to [BCS-98, "Removal and Installation"](#).

A  
B  
C  
D  
E  
F  
G  
H  
I  
J  
K  
L

BCS

# B2562 LOW VOLTAGE

< DTC/CIRCUIT DIAGNOSIS >

## B2562 LOW VOLTAGE

### DTC Logic

INFOID:000000011324351

### DTC DETECTION LOGIC

| DTC   | CONSULT display description | DTC Detection Condition  | Possible cause                              |
|-------|-----------------------------|--|---|
| B2562 | LOW VOLTAGE                 | When the power supply voltage to BCM remains less than 8.8 V for 120 seconds or more | Harness or connector (power supply circuit) |

### DTC CONFIRMATION PROCEDURE

#### 1. DTC CONFIRMATION

1. Erase DTC.
2. Turn ignition switch OFF.
3. Perform the "Self Diagnostic Result" of BCM with CONSULT, when passed 120 seconds or more after the ignition switch is turned ON.

#### Is any DTC detected?

- YES >> Refer to [BCS-90, "Diagnosis Procedure"](#).  
NO >> INSPECTION END

### Diagnosis Procedure

INFOID:000000011324352

#### 1. CHECK POWER SUPPLY CIRCUIT

Check BCM power supply circuit. Refer to [BCS-91, "Diagnosis Procedure"](#).

#### Is the circuit normal?

- YES >> Replace BCM. Refer to [BCS-98, "Removal and Installation"](#).  
NO >> Repair the malfunctioning part.

# POWER SUPPLY AND GROUND CIRCUIT

< DTC/CIRCUIT DIAGNOSIS >

## POWER SUPPLY AND GROUND CIRCUIT

### Diagnosis Procedure

INFOID:000000011324353

#### 1.CHECK FUSE AND FUSIBLE LINK

Check that the following fuse and fusible link are not blown.

| Signal name          | Fuse and fusible link No. |
|----------------------|---------------------------|
| Battery power supply | L                         |
|                      | 10                        |

#### Is the fuse fusing?

- YES >> Replace the blown fuse or fusible link after repairing the affected circuit if a fuse or fusible link is blown.  
NO >> GO TO 2.

#### 2.CHECK POWER SUPPLY CIRCUIT

1. Turn ignition switch OFF.
2. Disconnect BCM connectors.
3. Check voltage between BCM harness connector and ground.

| Terminals |          | Voltage<br>(Approx.) |
|-----------|----------|----------------------|
| (+)       | (-)      |                      |
| BCM       |          | Ground               |
| Connector | Terminal |                      |
| M123      | 70       |                      |
|           | 57       |                      |
|           |          | Battery voltage      |

#### Is the measurement value normal?

- YES >> GO TO 3.  
NO >> Repair harness or connector.

#### 3.CHECK GROUND CIRCUIT

Check continuity between BCM harness connector and ground.

| BCM       |          | Ground | Continuity |
|-----------|----------|--------|------------|
| Connector | Terminal |        |            |
| M123      | 67       |        | Existed    |

#### Does continuity exist?

- YES >> INSPECTION END  
NO >> Repair harness or connector.

A  
B  
C  
D  
E  
F  
G  
H  
I  
J  
K  
L  
N  
O  
P

BCS

# COMBINATION SWITCH OUTPUT CIRCUIT

< DTC/CIRCUIT DIAGNOSIS >

## COMBINATION SWITCH OUTPUT CIRCUIT

### Diagnosis Procedure

INFOID:000000011324354

#### 1. CHECK OUTPUT 1 - 5 CIRCUIT FOR OPEN

1. Turn ignition switch OFF.
2. Disconnect BCM and combination switch connectors.
3. Check continuity between BCM harness connector and combination switch harness connector.

| System   | BCM       |          | Combination switch |          | Continuity |
|----------|-----------|----------|--------------------|----------|------------|
|          | Connector | Terminal | Connector          | Terminal |            |
| OUTPUT 1 | M121      | 36       | M103               | 11       | Existed    |
| OUTPUT 2 |           | 35       |                    | 9        |            |
| OUTPUT 3 |           | 34       |                    | 7        |            |
| OUTPUT 4 |           | 33       |                    | 10       |            |
| OUTPUT 5 |           | 32       |                    | 13       |            |

Does continuity exist?

YES >> GO TO 2.

NO >> Repair harnesses or connectors.

#### 2. CHECK OUTPUT 1 - 5 CIRCUIT FOR SHORT

Check for continuity between BCM harness connector and ground.

| System   | BCM       |          | Ground | Continuity  |
|----------|-----------|----------|--------|-------------|
|          | Connector | Terminal |        |             |
| OUTPUT 1 | M121      | 36       | Ground | Not existed |
| OUTPUT 2 |           | 35       |        |             |
| OUTPUT 3 |           | 34       |        |             |
| OUTPUT 4 |           | 33       |        |             |
| OUTPUT 5 |           | 32       |        |             |

Does continuity exist?

YES >> Repair harnesses or connectors.

NO >> GO TO 3.

#### 3. CHECK BCM OUTPUT VOLTAGE

1. Connect BCM connector.
2. Check voltage between BCM harness connector and ground.

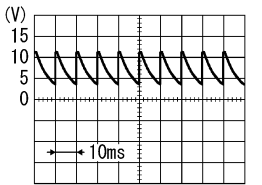
| System   | Terminals |          | Ground | Voltage (Approx.)  |
|----------|-----------|----------|--------|--|
|          | BCM       |          |        |  |
|          | Connector | Terminal |        |  |
| OUTPUT 1 | M121      | 36       | Ground |  |
| OUTPUT 2 |           | 35       |        |  |
| OUTPUT 3 |           | 34       |        |  |
| OUTPUT 4 |           | 33       |        |  |
| OUTPUT 5 |           | 32       |        |  |

Is the measurement value normal?

# COMBINATION SWITCH OUTPUT CIRCUIT

## < DTC/CIRCUIT DIAGNOSIS >

---

YES >> Replace combination switch.

NO >> Replace BCM. Refer to [BCS-98, "Removal and Installation"](#).

A

B

C

D

E

F

G

H

I

J

K

L

**BCS**

N

O

P

# COMBINATION SWITCH INPUT CIRCUIT

< DTC/CIRCUIT DIAGNOSIS >

## COMBINATION SWITCH INPUT CIRCUIT

### Diagnosis Procedure

INFOID:000000011324355

#### 1. CHECK INPUT 1 - 5 CIRCUIT FOR OPEN

1. Turn ignition switch OFF.
2. Disconnect BCM and combination switch connectors.
3. Check continuity between BCM harness connector and combination switch harness connector.

| System  | BCM       |          | Combination switch |          | Continuity |
|---------|-----------|----------|--------------------|----------|------------|
|         | Connector | Terminal | Connector          | Terminal |            |
| INPUT 1 | M121      | 6        | M103               | 12       | Existed    |
| INPUT 2 |           | 5        |                    | 14       |            |
| INPUT 3 |           | 4        |                    | 5        |            |
| INPUT 4 |           | 3        |                    | 2        |            |
| INPUT 5 |           | 2        |                    | 8        |            |

Does continuity exist?

YES >> GO TO 2.

NO >> Repair harnesses or connectors.

#### 2. CHECK INPUT 1 - 5 CIRCUIT FOR SHORT

Check for continuity between BCM harness connector and ground.

| System  | BCM       |          | Ground | Continuity  |
|---------|-----------|----------|--------|-------------|
|         | Connector | Terminal |        |             |
| INPUT 1 | M121      | 6        | Ground | Not existed |
| INPUT 2 |           | 5        |        |             |
| INPUT 3 |           | 4        |        |             |
| INPUT 4 |           | 3        |        |             |
| INPUT 5 |           | 2        |        |             |

Does continuity exist?

YES >> Repair harnesses or connectors.

NO >> GO TO 3.

#### 3. CHECK BCM INPUT SIGNAL

1. Connect BCM and combination switch connectors.
2. Turn ON any switch in the system that is malfunction.
3. Check voltage between BCM harness connector and ground.

| System  | Terminals |          | Voltage (Approx.) |
|---------|-----------|----------|-------------------|
|         | (+)       | (-)      |                   |
|         | BCM       |          |                   |
|         | Connector | Terminal |                   |
| INPUT 1 | M121      | 6        | Ground            |
| INPUT 2 |           | 5        |                   |
| INPUT 3 |           | 4        |                   |
| INPUT 4 |           | 3        |                   |
| INPUT 5 |           | 2        |                   |

Is the measurement value normal?

Yes >> Replace BCM. Refer to [BCS-98. "Removal and Installation"](#).

# COMBINATION SWITCH INPUT CIRCUIT

< DTC/CIRCUIT DIAGNOSIS >

---

No >> Replace combination switch.

A

B

C

D

E

F

G

H

I

J

K

L

**BCS**

N

O

P

# COMBINATION SWITCH SYSTEM SYMPTOMS

< SYMPTOM DIAGNOSIS >

## SYMPTOM DIAGNOSIS

### COMBINATION SWITCH SYSTEM SYMPTOMS

#### Symptom Table

INFOID:0000000011324356

1. Perform "Data Monitor" of CONSULT to check for any malfunctioning item.
2. Check the malfunction combinations.

Malfunction item: ×

| Data monitor item   |              |              |              |             |              |              |            |               |               |              |            |                |                |            |               | Malfunction combination |           |
|---|--------------|--------------|--------------|-------------|--------------|--------------|------------|---------------|---------------|--------------|------------|----------------|----------------|------------|---------------|-------------------------|-----------|
| FR WIPER HI   | FR WIPER LOW | FR WASHER SW | FR WIPER INT | RR WIPER ON | RR WIPER INT | RR WASHER SW | INT VOLUME | TURN SIGNAL R | TURN SIGNAL L | TAIL LAMP SW | HI BEAM SW | HEAD LAMP SW 1 | HEAD LAMP SW 2 | PASSING SW | AUTO LIGHT SW |                         | FR FOG SW |
|   | ×            | ×            |              |             |              |              |            | ×             | ×             |              |            |                |                |            |               |                         | A         |
| ×   |              |              | ×            |             |              |              |            |               |               |              |            | ×              |                | ×          |               |                         | B         |
|   |              |              |              |             |              | ×            | ×          |               |               |              | ×          |                | ×              |            |               |                         | C         |
|   |              |              |              |             | ×            |              | ×          |               |               | ×            |            |                |                |            | ×             |                         | D         |
|   |              |              |              | ×           |              |              | ×          |               |               |              |            |                |                |            |               | ×                       | E         |
| ×   |              |              |              |             | ×            |              | ×          |               |               |              |            |                |                |            |               |                         | F         |
|   |              | ×            |              | ×           |              | ×            | ×          |               |               |              |            |                |                |            |               |                         | G         |
|   | ×            |              | ×            |             |              |              |            |               |               |              |            |                |                |            | ×             |                         | H         |
|   |              |              |              |             |              |              |            |               | ×             |              |            |                | ×              | ×          |               | ×                       | I         |
|   |              |              |              |             |              |              |            | ×             |               | ×            | ×          | ×              |                |            |               |                         | J         |
| All Items   |              |              |              |             |              |              |            |               |               |              |            |                |                |            |               | K                       |           |
| If only one item is detected or the item is not applicable to the combinations A to K |              |              |              |             |              |              |            |               |               |              |            |                |                |            |               | L                       |           |

3. Identify the malfunctioning part from the agreed combination and repair or replace the part.

| Malfunction combination | Malfunctioning part                 | Repair or replace   |
|-------------------------|-------------------------------------|---|
| A                       | Combination switch OUTPUT 1 circuit | Inspect the combination switch output circuit applicable to the malfunctioning part. Refer to <a href="#">BCS-92, "Diagnosis Procedure"</a> . |
| B                       | Combination switch OUTPUT 2 circuit |   |
| C                       | Combination switch OUTPUT 3 circuit |   |
| D                       | Combination switch OUTPUT 4 circuit |   |
| E                       | Combination switch OUTPUT 5 circuit |   |
| F                       | Combination switch INPUT 1 circuit  | Inspect the combination switch input circuit applicable to the malfunctioning part. Refer to <a href="#">BCS-94, "Diagnosis Procedure"</a> .  |
| G                       | Combination switch INPUT 2 circuit  |   |
| H                       | Combination switch INPUT 3 circuit  |   |
| I                       | Combination switch INPUT 4 circuit  |   |
| J                       | Combination switch INPUT 5 circuit  |   |
| K                       | BCM                                 | Replace BCM. Refer to <a href="#">BCS-98, "Removal and Installation"</a> .  |
| L                       | Combination switch                  | Replace combination switch.   |



# NORMAL OPERATING CONDITION

< SYMPTOM DIAGNOSIS >

## NORMAL OPERATING CONDITION

### Description

INFOID:000000011324357

#### SHIPPING MODE

- Shipping mode inhibits battery power consumption during transportation or storage of the vehicle. Vehicle is set to shipping mode before being shipped from the factory.
- When ignition switch is OFF, BCM operates shipping mode.
- BCM control functions are limited in shipping mode. The limited items that are not operated during the shipping mode are as follows.
  - Door lock and unlock switch function
  - Remote keyless entry function
  - Theft warning alarm function
  - Lighting & turn signal switch function
  - Interior room lamp timer control function
- For shipping mode cancel operation, refer to [BCS-86, "Description"](#).

#### NOTE:

Do not cancel shipping mode during storage of the vehicle. Always cancel shipping mode before delivery of the vehicle to customer.

A  
B  
C  
D  
E  
F  
G  
H  
I  
J  
K  
L  
N  
O  
P

BCS

# BCM

< REMOVAL AND INSTALLATION >

---

## REMOVAL AND INSTALLATION

### BCM

#### Removal and Installation

INFOID:000000011324358

**NOTE:**

Before replacing BCM, perform "READ CONFIGURATION" to save or print current vehicle specification. Refer to [BCS-83. "ADDITIONAL SERVICE WHEN REPLACING CONTROL UNIT \(BCM\) : Description"](#).

#### REMOVAL

1. Remove combination meter. Refer to [MWI-90. "Removal and Installation"](#).
2. Remove bolts.
3. Remove BCM and disconnect the connectors.

#### INSTALLATION

Install in the reverse order of removal.

**CAUTION:**

**Be sure to perform "WRITE CONFIGURATION" when replacing BCM. Or not doing so, BCM control function does not operate normally.**

**NOTE:**

Be sure to perform the system initialization (NATS) when replacing BCM. Refer to [BCS-83. "ADDITIONAL SERVICE WHEN REPLACING CONTROL UNIT \(BCM\) : Work Procedure"](#).

# COMBINATION SWITCH

< REMOVAL AND INSTALLATION >

## COMBINATION SWITCH

Exploded View

INFOID:000000011324359

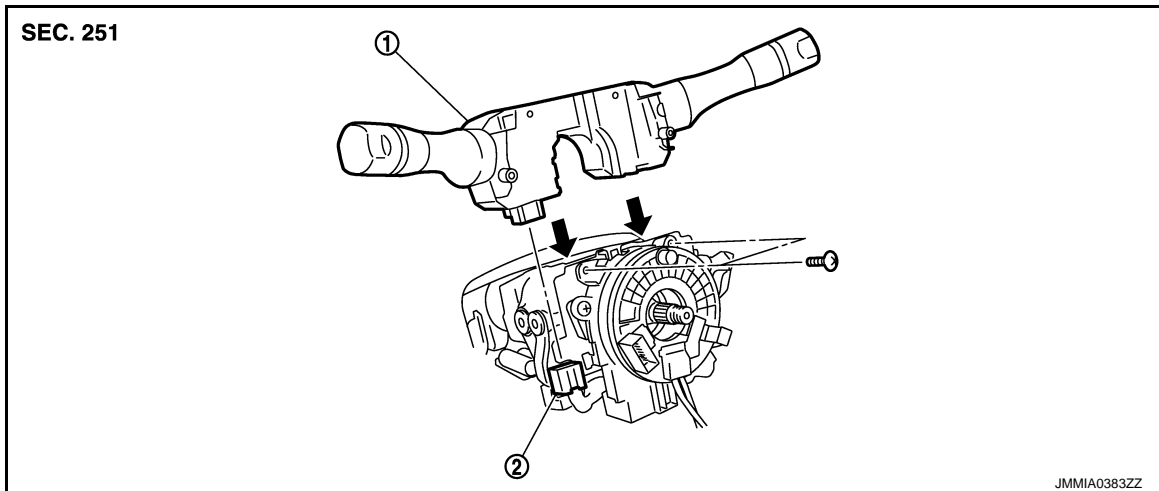

1. Combination switch

2. Combination switch connector

## Removal and Installation

INFOID:000000011324360

### REMOVAL

1. Remove steering column cover. Refer to [IP-14. "Removal and Installation"](#).
2. Remove screws.
3. Disconnect the connector.
4. Pull up the combination switch to remove it.

### INSTALLATION

Install in the reverse order of removal.

A  
B  
C  
D  
E  
F  
G  
H  
I  
J  
K  
L

BCS

N  
O  
P