

SECTION BR
BRAKE SYSTEM

A
B
C
D
E

CONTENTS

PRECAUTION	3	BRAKE MASTER CYLINDER	14	BR
PRECAUTIONS	3	Inspection	14	
Precaution for Supplemental Restraint System (SRS) "AIR BAG" and "SEAT BELT PRE-TEN- SIONER"	3	BRAKE BOOSTER	15	G
Precaution for Procedure without Cowl Top Cover.....	3	Inspection	15	
Precaution for Brake System	3	FRONT DISC BRAKE	16	H
Precautions for Removing Battery Terminal	4	BRAKE PAD	16	
PREPARATION	5	BRAKE PAD : Inspection and Adjustment	16	
PREPARATION	5	DISC ROTOR	16	I
Commercial Service Tool	5	DISC ROTOR : Inspection and Adjustment	16	
BASIC INSPECTION	6	REAR DISC BRAKE	18	J
FRONT DISC BRAKE	6	BRAKE PAD	18	
DISC ROTOR	6	BRAKE PAD : Inspection and Adjustment	18	K
DISC ROTOR : Inspection	6	DISC ROTOR	18	
REAR DISC BRAKE	7	DISC ROTOR : Inspection and Adjustment	18	L
DISC ROTOR	7	REMOVAL AND INSTALLATION	20	
DISC ROTOR : Inspection	7	BRAKE PEDAL	20	M
SYMPTOM DIAGNOSIS	8	Exploded View	20	
NOISE, VIBRATION AND HARSHNESS (NVH) TROUBLESHOOTING	8	Removal and Installation	20	
NVH Troubleshooting Chart	8	Inspection and Adjustment	21	
PERIODIC MAINTENANCE	9	BRAKE PIPING	22	N
BRAKE PEDAL	9	FRONT	22	
Inspection and Adjustment	9	FRONT : Exploded View	22	O
BRAKE FLUID	12	FRONT : Hydraulic Piping	23	
Inspection	12	FRONT : Removal and Installation	23	
Draining	12	FRONT : Inspection	24	P
Refilling	12	REAR	25	
Bleeding Brake System	13	REAR : Exploded View	25	
		REAR : Hydraulic Piping	26	
		REAR : Removal and Installation	26	
		REAR : Inspection	27	
		BRAKE MASTER CYLINDER	29	

Exploded View	29	BRAKE CALIPER ASSEMBLY : Inspection	44
Removal and Installation	29	REAR DISC BRAKE	45
Disassembly and Assembly	31	BRAKE PAD	45
Inspection	32	BRAKE PAD : Exploded View	45
BRAKE BOOSTER	33	BRAKE PAD : Removal and Installation	45
Exploded View	33	BRAKE PAD : Inspection	47
Removal and installation	33	BRAKE CALIPER ASSEMBLY	47
Inspection and Adjustment	34	BRAKE CALIPER ASSEMBLY : Exploded View ...	47
VACUUM LINES	35	BRAKE CALIPER ASSEMBLY : Removal and In-	49
Exploded View	35	stallation	49
Removal and Installation	35	BRAKE CALIPER ASSEMBLY : Disassembly and	50
Inspection	35	Assembly	50
FRONT DISC BRAKE	37	BRAKE CALIPER ASSEMBLY : Inspection	52
BRAKE PAD	37	SERVICE DATA AND SPECIFICATIONS	
BRAKE PAD : Exploded View	37	(SDS)	53
BRAKE PAD : Removal and Installation	37	SERVICE DATA AND SPECIFICATIONS	
BRAKE PAD : Inspection	39	(SDS)	53
BRAKE CALIPER ASSEMBLY	39	General Specifications	53
BRAKE CALIPER ASSEMBLY : Exploded View ...	39	Brake Pedal	53
BRAKE CALIPER ASSEMBLY : Removal and In-	41	Brake Booster	53
stallation	41	Front Disc Brake	53
BRAKE CALIPER ASSEMBLY : Disassembly and	42	Rear Disc Brake	53
Assembly	42		

PRECAUTIONS

< PRECAUTION >

PRECAUTION

PRECAUTIONS

Precaution for Supplemental Restraint System (SRS) "AIR BAG" and "SEAT BELT PRE-TENSIONER"

INFOID:000000011326098

The Supplemental Restraint System such as "AIR BAG" and "SEAT BELT PRE-TENSIONER", used along with a front seat belt, helps to reduce the risk or severity of injury to the driver and front passenger for certain types of collision. This system includes seat belt switch inputs and dual stage front air bag modules. The SRS system uses the seat belt switches to determine the front air bag deployment, and may only deploy one front air bag, depending on the severity of a collision and whether the front occupants are belted or unbelted. Information necessary to service the system safely is included in the "SRS AIR BAG" and "SEAT BELT" of this Service Manual.

WARNING:

Always observe the following items for preventing accidental activation.

- To avoid rendering the SRS inoperative, which could increase the risk of personal injury or death in the event of a collision that would result in air bag inflation, all maintenance must be performed by an authorized NISSAN/INFINITI dealer.
- Improper maintenance, including incorrect removal and installation of the SRS, can lead to personal injury caused by unintentional activation of the system. For removal of Spiral Cable and Air Bag Module, see "SRS AIR BAG".
- Never use electrical test equipment on any circuit related to the SRS unless instructed to in this Service Manual. SRS wiring harnesses can be identified by yellow and/or orange harnesses or harness connectors.

PRECAUTIONS WHEN USING POWER TOOLS (AIR OR ELECTRIC) AND HAMMERS

WARNING:

Always observe the following items for preventing accidental activation.

- When working near the Air Bag Diagnosis Sensor Unit or other Air Bag System sensors with the ignition ON or engine running, never use air or electric power tools or strike near the sensor(s) with a hammer. Heavy vibration could activate the sensor(s) and deploy the air bag(s), possibly causing serious injury.
- When using air or electric power tools or hammers, always switch the ignition OFF, disconnect the battery, and wait at least 3 minutes before performing any service.

Precaution for Procedure without Cowl Top Cover

INFOID:000000011326099

When performing the procedure after removing cowl top cover, cover the lower end of windshield with urethane, etc to prevent damage to windshield.

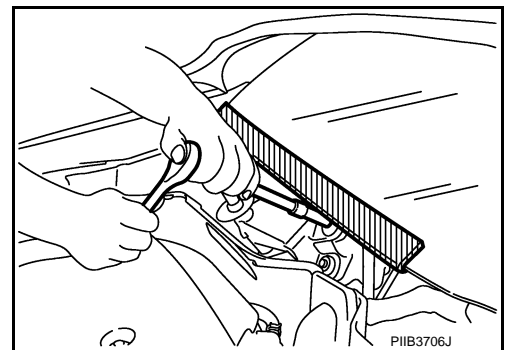

Precaution for Brake System

INFOID:000000011326100

WARNING:

Since dust covering the front and rear brakes has an affect on human body, the dust must be removed with a dust collector. Never splatter the dust with an air blow gun.

- Brake fluid use refer to [MA-10, "Fluids and Lubricants"](#).
- Never reuse drained brake fluid.
- Never spill or splash brake fluid on painted surfaces. Brake fluid may seriously damage paint. Wipe it off immediately and wash with water if it gets on a painted surface. For brake component parts, never wash them with water.

PRECAUTIONS

< PRECAUTION >

- Always confirm the specified tightening torque when installing the brake pipes.
- After pressing the brake pedal more deeply or harder than normal driving, such as air bleeding, check each item of brake pedal. Adjust brake pedal if it is outside the standard value.
- Always clean with new brake fluid when cleaning the master cylinder, brake caliper and other components.
- Never use mineral oils such as gasoline or light oil to clean. They may damage rubber parts and cause improper operation.
- Always loosen the brake tube flare nut with a flare nut wrench.
- Tighten the brake tube flare nut to the specified torque with a crow-foot (A) and torque wrench (B).
- Turn the ignition switch OFF and disconnect the ABS actuator and electric unit (control unit) harness connector or the battery negative terminal before performing the work.
- Check that no brake fluid leakage is present after replacing the parts.
- Burnish the brake contact surfaces after refinishing or replacing rotors, after replacing pads, or if a soft pedal occurs at very low mileage.
- Front brake pad: Refer to [BR-16, "BRAKE PAD : Inspection and Adjustment"](#).
- Front disc rotor: Refer to [BR-16, "DISC ROTOR : Inspection and Adjustment"](#).
- Rear brake pad: Refer to [BR-18, "BRAKE PAD : Inspection and Adjustment"](#).
- Rear disc rotor: Refer to [BR-18, "DISC ROTOR : Inspection and Adjustment"](#).

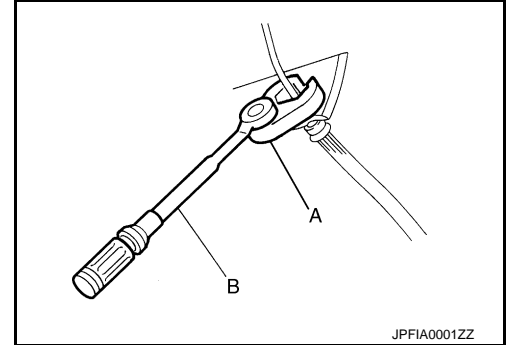

Precautions for Removing Battery Terminal

INFOID:000000011326101

- When removing the 12V battery terminal, turn OFF the ignition switch and wait at least 30 seconds.

NOTE:

ECU may be active for several tens of seconds after the ignition switch is turned OFF. If the battery terminal is removed before ECU stops, then a DTC detection error or ECU data corruption may occur.

- For vehicles with the 2-batteries, be sure to connect the main battery and the sub battery before turning ON the ignition switch.

NOTE:

If the ignition switch is turned ON with any one of the terminals of main battery and sub battery disconnected, then DTC may be detected.

- After installing the 12V battery, always check "Self Diagnosis Result" of all ECUs and erase DTC.

NOTE:

The removal of 12V battery may cause a DTC detection error.

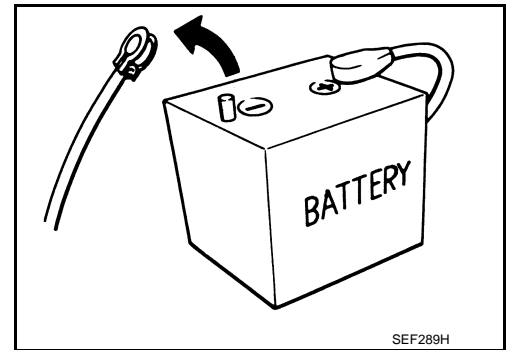

PREPARATION



< PREPARATION >

PREPARATION

PREPARATION

Commercial Service Tool

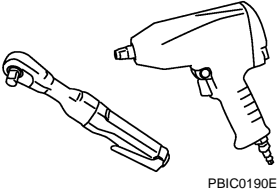
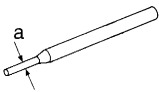
INFOID:000000011326102

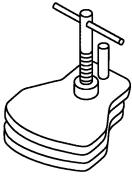
Tool name	Description
<p>Power tool</p>  <p>PBIC0190E</p>	<p>Loosening bolts and nuts</p>
<p>Pin punch a: 4 mm (0.16 in)</p>  <p>NT410</p>	<p>Removing and installing reservoir tank</p>
<p>Handy vacuum pump</p>  <p>ZZC1313D</p>	<ul style="list-style-type: none"> • Air tight • Inspection of check valve
<p>Brake caliper wrench</p>  <p>NNFIA0040ZZ</p>	<p>Return the piston</p>

A

B

C

D

E

BR

G

H

I

J

K

L

M

N

O

P

FRONT DISC BRAKE

< BASIC INSPECTION >

BASIC INSPECTION

FRONT DISC BRAKE

DISC ROTOR

DISC ROTOR : Inspection

INFOID:000000011508668

INSPECTION

Uneven wear

Check the uneven wear of the disc rotor using a micrometer.
Replace the disc rotor if the thickness is below the wear limit. Refer to [FAX-9, "Removal and Installation"](#).

Thickness variation (measured at 8 positions) : Refer to [BR-53, "Front Disc Brake"](#).

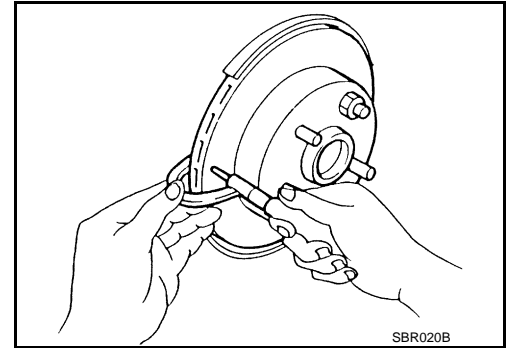

REAR DISC BRAKE

< BASIC INSPECTION >

REAR DISC BRAKE

DISC ROTOR

DISC ROTOR : Inspection

INFOID:000000011508669

INSPECTION

Uneven wear

Check the uneven wear of the disc rotor using a micrometer. Replace the disc rotor if the thickness is below the wear limit. Refer to [RAX-7, "Removal and Installation"](#).

Thickness variation : Refer to [BR-53, "Rear Disc Brake"](#).
(measured at 8 positions)

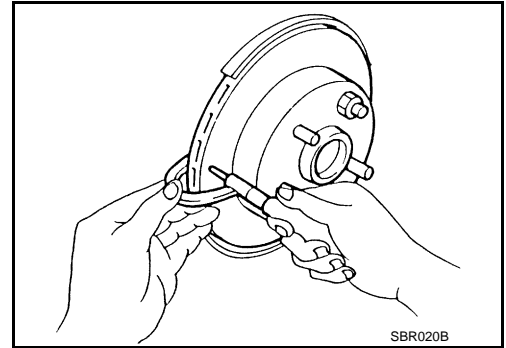

A

B

C

D

E

BR

G

H

I

J

K

L

M

N

O

P

NOISE, VIBRATION AND HARSHNESS (NVH) TROUBLESHOOTING

< SYMPTOM DIAGNOSIS >

SYMPTOM DIAGNOSIS

NOISE, VIBRATION AND HARSHNESS (NVH) TROUBLESHOOTING

NVH Troubleshooting Chart

INFOID:000000011326103

Use the chart below to find the cause of the symptom. If necessary, repair or replace these parts.

Symptom	BRAKE	Possible cause and SUSPECTED PARTS	Reference page															
			BR-16, BR-18	BR-16, BR-18	BR-39, BR-47	BR-16, BR-18, BR-6, BR-7	BR-16, BR-18, BR-6, BR-7	BR-16, BR-18	BR-16, BR-18	BR-16, BR-18	BR-16, BR-18	BR-16, BR-18, BR-6, BR-7	NVH in PB section	NVH in FAX, RAX and FSU, RSU section	NVH in WT section	NVH in WT section	NVH in FAX section	NVH in ST section
		Pads damaged	×	×	×						×			×	×	×	×	×
		Pads uneven wear		×										×	×	×	×	×
		Shims damaged																
		Rotor imbalance				×								×	×	×	×	×
		Rotor damage				×	×	×	×	×				×	×	×	×	×
		Rotor runout																
		Rotor deformation																
		Rotor deflection																
		Rotor rust									×							
		Rotor thickness variation									×							
		Drum out of round																
		AXLE AND SUSPENSION												×	×	×	×	×
		TIRE													×	×	×	×
		ROAD WHEEL													×	×	×	×
		DRIVE SHAFT														×	×	×
		STEERING															×	×

×: Applicable

BRAKE PEDAL

< PERIODIC MAINTENANCE >

PERIODIC MAINTENANCE

BRAKE PEDAL

Inspection and Adjustment

INFOID:000000011326104

INSPECTION

Brake Pedal Height

Check the height (H_1) between the dash lower panel (1) and the brake pedal upper surface.

H_1 : Refer to [BR-53, "Brake Pedal"](#).

CAUTION:

Remove the floor trim.

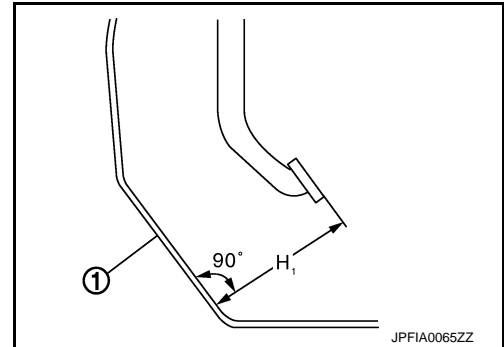

Stop Lamp Switch and Brake Switch

Check the clearance (C) among the stopper rubber (1) and the stop lamp switch and brake switch (2) threaded end.

C : Refer to [BR-53, "Brake Pedal"](#).

CAUTION:

The stop lamp must turn off when the brake pedal is released.

NOTE:

Pull the brake pedal pad to make the clearance between the stop lamp switch and brake switch threaded end and the stopper rubber.

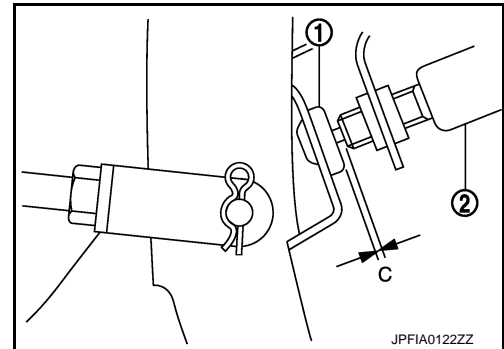

Brake Pedal Play

Press the brake pedal. Check the brake pedal play (A) (stroke until fluid pressure occurs).

A : Refer to [BR-53, "Brake Pedal"](#).

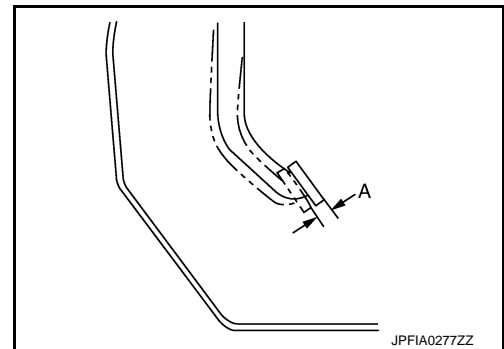

Depressed Brake Pedal Height

Check the height between the dash lower panel (1) and the brake pedal upper surface (H_2) when depressing the brake pedal at 490 N (50 kg, 110 lb) while turning engine ON.

H_2 : Refer to [BR-53, "Brake Pedal"](#).

CAUTION:

Remove the floor trim.

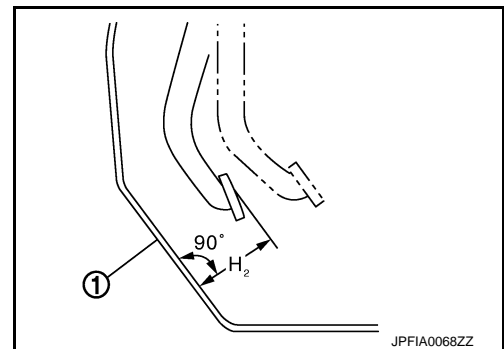

ADJUSTMENT

A
B
C
D
E
BR
G
H
I
J
K
L
M
N
O
P

BRAKE PEDAL

< PERIODIC MAINTENANCE >

Brake Pedal Height

1. Remove instrument lower panel LH. Refer to [IP-14, "Removal and Installation"](#).
2. Disconnect the stop lamp switch and brake switch harness connector.
3. Loosen the stop lamp switch and brake switch 45° counterclockwise.
4. Loosen the lock nut of input rod (1).
5. Rotate the input rod (2), adjust the brake pedal to the specified height (H₁).

CAUTION:

The threaded end of the input rod must project to the inner side of the clevis (3).

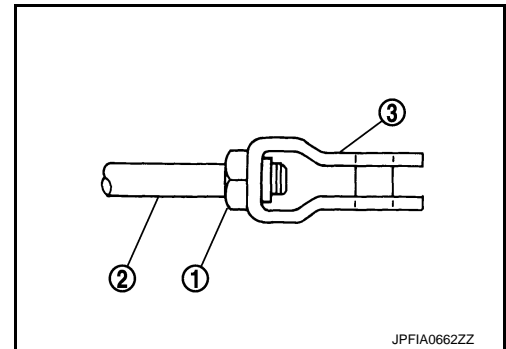

H₁ : Refer to [BR-53, "Brake Pedal"](#).

6. Tighten the lock nut. Refer to [BR-33, "Exploded View"](#).

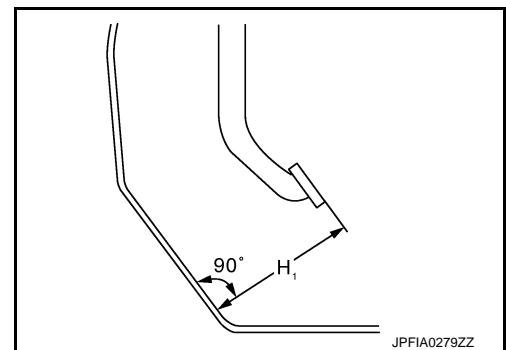

Stop Lamp Switch and Brake Switch

1. Remove instrument lower panel LH. Refer to [IP-14, "Removal and Installation"](#).
2. Disconnect the stop lamp switch and brake switch harness connector.
3. Loosen the stop lamp switch and brake switch 45° counterclockwise.
4. Press-fit the stop lamp switch and brake switch (2) until the stop lamp switch and brake switch hits the stopper rubber (1) 45° clockwise while pulling the brake pedal pad slightly.

CAUTION:

- The clearance (C) between the stopper rubber and stop lamp switch and brake switch threaded end must be the specified value.

C : Refer to [BR-53, "Brake Pedal"](#).

- The stop lamp must be turned off when the brake pedal is released.

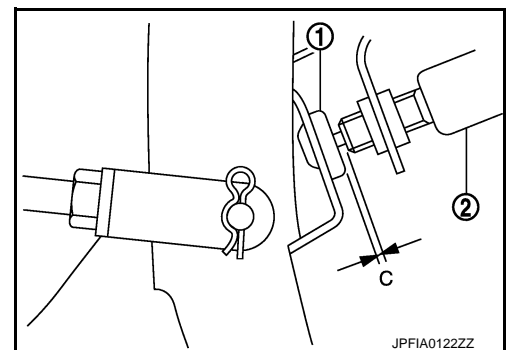

Brake Pedal Play

1. Remove instrument lower panel LH. Refer to [IP-14, "Removal and Installation"](#).
2. Disconnect the stop lamp switch and brake switch harness connector.
3. Loosen the stop lamp switch and brake switch 45° counterclockwise.

BRAKE PEDAL

< PERIODIC MAINTENANCE >

4. Press-fit the stop lamp switch and brake switch (2) until the stop lamp switch and brake switch hits the stopper rubber (1) 45° clockwise while pulling the brake pedal pad slightly.

CAUTION:

- The clearance (C) between the stopper rubber and stop lamp switch and brake switch threaded end must be the specified value.

C : Refer to [BR-53, "Brake Pedal"](#).

- The stop lamp must be turned off when the brake pedal is released.

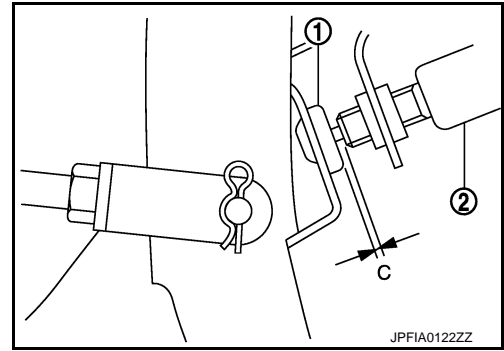

Depressed Brake Pedal Height

1. Perform the air bleeding. Refer to [BR-13, "Bleeding Brake System"](#).
2. Check the height between the dash lower panel (1) and the brake pedal upper surface (H₂) when depressing the brake pedal at 490 N (50 kg, 110 lb) while turning engine ON.

H₂ : Refer to [BR-53, "Brake Pedal"](#).

CAUTION:

Remove the floor trim.

3. Adjust brake pedal height and brake pedal play.

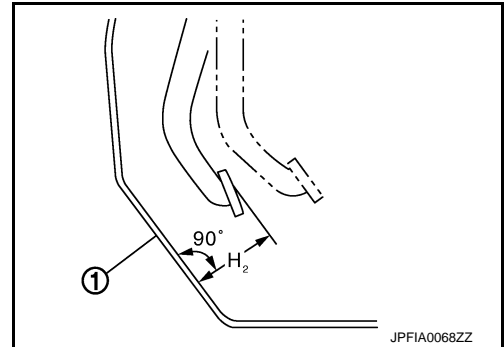

A
B
C
D
E
BR
G
H
I
J
K
L
M
N
O
P

BRAKE FLUID

< PERIODIC MAINTENANCE >

BRAKE FLUID

Inspection

INFOID:000000011326105

BRAKE FLUID LEVEL

- Check that the fluid level in the reservoir tank is within the specified range (MAX – MIN lines).
- Visually check for any brake fluid leakage around the reservoir tank and sub tank.
- Check the brake system for any leakage if the fluid level is extremely low (lower than MIN).
- Check the brake system for fluid leakage if the warning lamp remains illuminated even after the parking brake is released.
- Check the reservoir tank and sub tank for the mixing of foreign matter (e.g. dust) and oils other than brake fluid.

BRAKE LINE

1. Check brake line (tubes and hoses) for cracks, deterioration or other damage. Replace any damaged parts.
2. Depress the brake pedal with a force of 785 N (80 kg, 176 lb) and hold down the pedal for approximately 5 seconds with the engine running. Check for any fluid leakage.

CAUTION:

Retighten the applicable connection to the specified torque and repair any abnormal (damaged, worn or deformed) part if any brake fluid leakage is present.

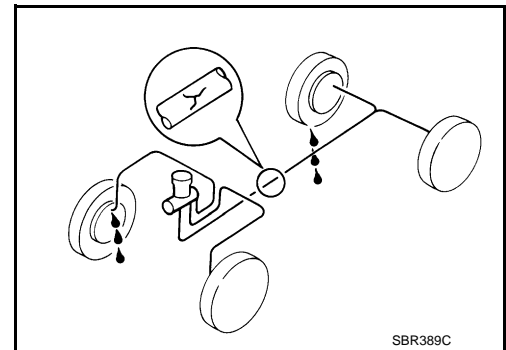

Draining

INFOID:000000011326106

CAUTION:

- Never spill or splash brake fluid on painted surfaces. Brake fluid may seriously damage paint. Wipe it off immediately and wash with water if it gets on a painted surface. For brake component parts, never wash them with water.
- Turn the ignition switch OFF and disconnect the ABS actuator and electric unit (control unit) harness connector or the battery negative terminal before performing work.
- If the brake fluid adheres to the brake caliper assembly and disc rotor, quickly wipe it off.

1. Connect a vinyl tube to the bleed valve.
2. Depress the brake pedal and loosen the bleeder valve to gradually discharge brake fluid.

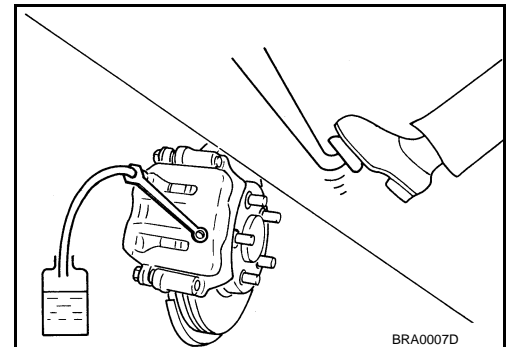

Refilling

INFOID:000000011326107

CAUTION:

- Turn the ignition switch OFF and disconnect the ABS actuator and electric unit (control unit) harness connector or the battery negative terminal before performing work.
- Never spill or splash brake fluid on painted surfaces. Brake fluid may seriously damage paint. Wipe it off immediately and wash with water if it gets on a painted surface. For brake component parts, never wash them with water.

1. Check that there is no foreign material in the reservoir tank and sub tank, and refill with new brake fluid.

CAUTION:

- Never reuse drained brake fluid.

BRAKE FLUID

< PERIODIC MAINTENANCE >

- **Never allow oils other than brake fluid to enter the reservoir tank.**
2. Loosen the bleeder valve, slowly depress the brake pedal to the full stroke, and then release the pedal. Repeat this operation at intervals of 2 or 3 seconds until new brake fluid is discharged. Then close the bleeder valve with the brake pedal depressed. Repeat the same work on each wheel. A
 3. Perform the air bleeding. Refer to [BR-13. "Bleeding Brake System"](#). B

Bleeding Brake System

INFOID:000000011326108

CAUTION:

- Turn the ignition switch OFF and disconnect the ABS actuator and electric unit (control unit) harness connector or the battery negative terminal before performing the work. C
- Monitor the fluid level in the reservoir tank while performing the air bleeding D
- Never spill or splash brake fluid on painted surfaces. Brake fluid may seriously damage paint. Wipe it off immediately and wash with water if it gets on a painted surface. For brake component parts, never wash them with water. E
- If the brake fluid adheres to the brake caliper assembly and disc rotor, quickly wipe it off.

1. Check that there is no foreign material in the reservoir tank and sub tank, and refill with new brake fluid.

CAUTION:

- **Never reuse drained brake fluid.**
 - **Never allow oils other than brake fluid to enter the reservoir tank.**
2. Connect a vinyl tube to the bleeder valve of the rear right brake. BR
 3. Fully depress the brake pedal 4 to 5 times. G
 4. Loosen the bleeder valve and bleed air with the brake pedal depressed, and then quickly tighten the bleeder valve. H
 5. Repeat steps 3 and 4 until all of the air is out of the brake line. I
 6. Tighten the bleeder valve to the specified torque.
 - Front disc brake: Refer to [BR-39. "BRAKE CALIPER ASSEMBLY : Exploded View"](#).
 - Rear disc brake: Refer to [BR-47. "BRAKE CALIPER ASSEMBLY : Exploded View"](#). J
 7. Perform steps 2 to 6. Occasionally fill with the brake fluid in order to keep it in the reservoir tank at least half of MAX line. Bleed air in the following order: rear right brake → front left brake → rear left brake → and front right brake in order. K
 8. Check that the fluid level in the reservoir tank is within the specified range after air bleeding. Refer to [BR-12. "Inspection"](#). L
 9. Check each item of brake pedal. Adjust it if the measurement value is not the standard. Refer to [BR-9. "Inspection and Adjustment"](#). M

BRAKE MASTER CYLINDER

< PERIODIC MAINTENANCE >

BRAKE MASTER CYLINDER

Inspection

INFOID:000000011326109

FLUID LEAK

Check for brake fluid leakage from the master cylinder mounting face, reservoir tank mounting face, sub tank mounting face and brake tube connections.

BRAKE BOOSTER

< PERIODIC MAINTENANCE >

BRAKE BOOSTER

Inspection

INFOID:000000011326110

OPERATION

Depress the brake pedal several times at 5-second intervals with the engine stopped. Start the engine with the brake pedal fully depressed. Check that the clearance between brake pedal and dash lower panel decreases.

AIR TIGHT

1. Run the engine at idle for 1 minute to apply vacuum to the brake booster, and stop the engine.
2. Depress the brake pedal several times at 5-second intervals until the accumulated vacuum is released to atmospheric pressure. Check that the clearance between brake pedal and dash lower panel gradually increases each time the brake pedal is depressed when performing this operation.
3. Depress the brake pedal with the engine running. Then stop the engine while holding down the brake pedal. Check that the brake pedal stroke does not change after holding down the brake pedal for 30 seconds or more.

A
B
C
D
E
G
H
I
J
K
L
M
N
O
P

BR

FRONT DISC BRAKE

< PERIODIC MAINTENANCE >

FRONT DISC BRAKE

BRAKE PAD

BRAKE PAD : Inspection and Adjustment

INFOID:000000011326111

INSPECTION

Check brake pad wear thickness from an inspection hole on cylinder body. Check using a scale if necessary.

Wear thickness : Refer to [BR-53, "Front Disc Brake"](#).

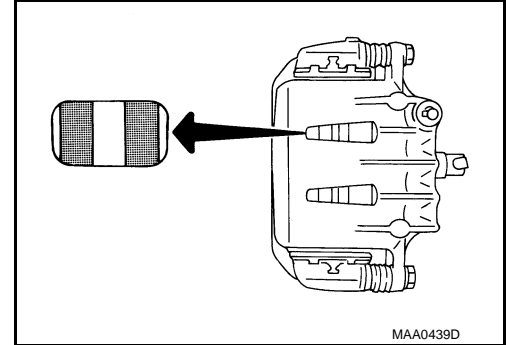

ADJUSTMENT

Burnish contact surfaces between disc rotor and brake pads according to the following procedure after refinishing or replacing brake pads, or if a soft pedal occurs at very low mileage.

CAUTION:

- **Be careful of vehicle speed because the brake does not operate firmly/securely until pads and disc rotor are securely fitted.**
- **Only perform this procedure under safe road and traffic conditions. Use extreme caution.**

1. Drive vehicle on straight, flat road.
2. Depress brake pedal with the power to stop vehicle within 3 to 5 seconds until the vehicle stops.
3. Drive without depressing brake for a few minutes to cool the brake.
4. Repeat steps 1 to 3 until pad and disc rotor are securely fitted.

DISC ROTOR

DISC ROTOR : Inspection and Adjustment

INFOID:000000011326112

INSPECTION

Appearance

Check surface of disc rotor for uneven wear, cracks, and serious damage. Replace it if necessary. Refer to [FAX-9, "Removal and Installation"](#).

Runout

1. Fix the disc rotor to the wheel hub and bearing assembly with wheel nuts (2 points at least).
2. Check the wheel bearing axial end play before the inspection. Refer to [FAX-7, "Inspection"](#).
3. Inspect the runout with a dial indicator to measure at 10 mm (0.39 in) inside the disc edge.

Runout (with it attached to the vehicle) : Refer to [BR-53, "Front Disc Brake"](#).

4. Find the installation position that has a minimum runout by shifting the disc rotor-to-wheel hub and bearing assembly installation position by one hole at a time if the runout exceeds the limit value.
- Refinish the disc rotor if the runout is outside the limit even after performing the above operation. [When refinishing, use the Pro-Cut PEM On-Car brake Lathe (Tool No. 38-PFM90.5) or equivalent.]

CAUTION:

- **Check in advance that the thickness of the disc rotor is wear thickness + 0.3 mm (0.012 in) or more.**

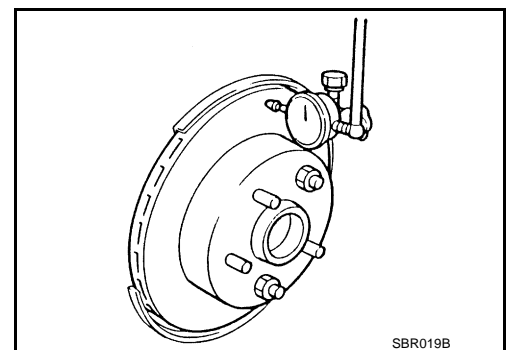

FRONT DISC BRAKE

< PERIODIC MAINTENANCE >

- If the thickness is less than wear thickness + 0.3 mm (0.012 in), replace the disc rotor. Refer to [FAX-9, "Removal and Installation"](#).

Wear thickness : Refer to [BR-53, "Front Disc Brake"](#).

Thickness

Check the thickness of the disc rotor using a micrometer. Replace the disc rotor if the thickness is below the wear limit. Refer to [FAX-9, "Removal and Installation"](#).

Wear thickness : Refer to [BR-53, "Front Disc Brake"](#).

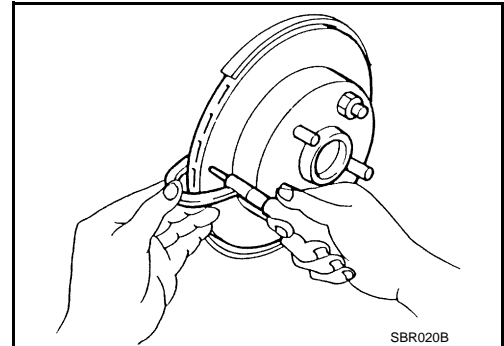

ADJUSTMENT

Burnish contact surfaces between disc rotors and brake pads according to the following procedure after refinishing or replacing disc rotor, or if a soft pedal occurs at very low mileage.

CAUTION:

- Be careful of vehicle speed because the brake does not operate firmly/securely until pad and disc rotor are securely fitted.
 - Only perform this procedure under safe road and traffic conditions. Use extreme caution.
1. Drive vehicle on straight, flat road.
 2. Depress brake pedal with the power to stop vehicle within 3 to 5 seconds until the vehicle stops.
 3. Drive without depressing brake for a few minutes to cool the brake.
 4. Repeat steps 1 to 3 until pad and disc rotor are securely fitted.

REAR DISC BRAKE

< PERIODIC MAINTENANCE >

REAR DISC BRAKE

BRAKE PAD

BRAKE PAD : Inspection and Adjustment

INFOID:000000011326113

INSPECTION

Check brake pad wear thickness from an inspection hole on cylinder body. Check using a scale if necessary.

Wear thickness : Refer to [BR-53, "Rear Disc Brake"](#).

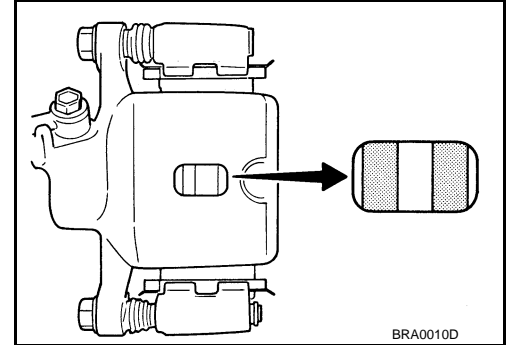

ADJUSTMENT

Burnish contact surfaces between disc rotor and brake pads according to the following procedure after refinishing or replacing brake pads, or if a soft pedal occurs at very low mileage.

CAUTION:

- **Be careful of vehicle speed because the brake does not operate firmly/securely until pads and disc rotor are securely fitted.**
 - **Only perform this procedure under safe road and traffic conditions. Use extreme caution.**
1. Drive vehicle on straight, flat road.
 2. Depress brake pedal with the power to stop vehicle within 3 to 5 seconds until the vehicle stops.
 3. Drive without depressing brake for a few minutes to cool the brake.
 4. Repeat steps 1 to 3 until pad and disc rotor are securely fitted.

DISC ROTOR

DISC ROTOR : Inspection and Adjustment

INFOID:000000011326114

INSPECTION

Appearance

Check surface of disc rotor for uneven wear, cracks, and serious damage. Replace it if necessary. Refer to [RAX-7, "Removal and Installation"](#).

Runout

1. Fix the disc rotor to the wheel hub and bearing assembly with wheel nuts (2 points at least).
2. Check the wheel bearing axial end play before the inspection. Refer to [RAX-5, "Inspection"](#).
3. Inspect the runout with a dial indicator to measure at 10 mm (0.39 in) inside the disc edge.

Runout (with it attached to the vehicle) : Refer to [BR-53, "Rear Disc Brake"](#).

4. Find the installation position that has a minimum runout by shifting the disc rotor-to-wheel hub and bearing assembly installation position by one hole at a time if the runout exceeds the limit value.

• Refinish the disc rotor if the runout is outside the limit even after performing the above operation. [When refinishing, use the Pro-Cut PEM On-Car brake Lathe (Tool No. 38-PFM90.5) or equivalent.]

CAUTION:

- **Check in advance that the thickness of the disc rotor is wear thickness + 0.3 mm (0.012 in) or more.**

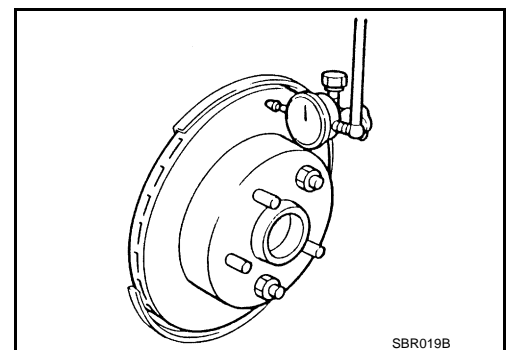

REAR DISC BRAKE

< PERIODIC MAINTENANCE >

- If the thickness is less than wear thickness + 0.3 mm (0.012 in), replace the disc rotor. Refer to [RAX-7, "Removal and Installation"](#).

Wear thickness : Refer to [BR-53, "Rear Disc Brake"](#).

Thickness

Check the thickness of the disc rotor using a micrometer. Replace the disc rotor if the thickness is below the wear limit. Refer to [RAX-7, "Removal and Installation"](#).

Wear thickness : Refer to [BR-53, "Rear Disc Brake"](#).

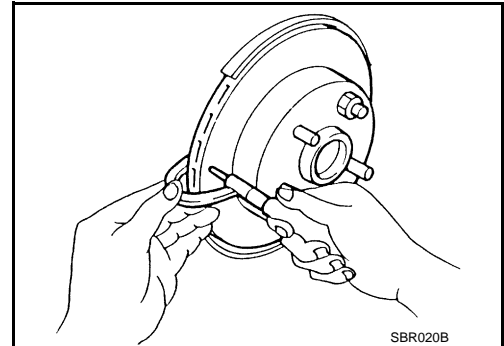

ADJUSTMENT

Burnish contact surfaces between disc rotors and brake pads according to the following procedure after refinishing or replacing disc rotor, or if a soft pedal occurs at very low mileage.

CAUTION:

- Be careful of vehicle speed because the brake does not operate firmly/securely until pad and disc rotor are securely fitted.
 - Only perform this procedure under safe road and traffic conditions. Use extreme caution.
1. Drive vehicle on straight, flat road.
 2. Depress brake pedal with the power to stop vehicle within 3 to 5 seconds until the vehicle stops.
 3. Drive without depressing brake for a few minutes to cool the brake.
 4. Repeat steps 1 to 3 until pad and disc rotor are securely fitted.

BRAKE PEDAL

< REMOVAL AND INSTALLATION >

REMOVAL AND INSTALLATION

BRAKE PEDAL

Exploded View

INFOID:000000011326115

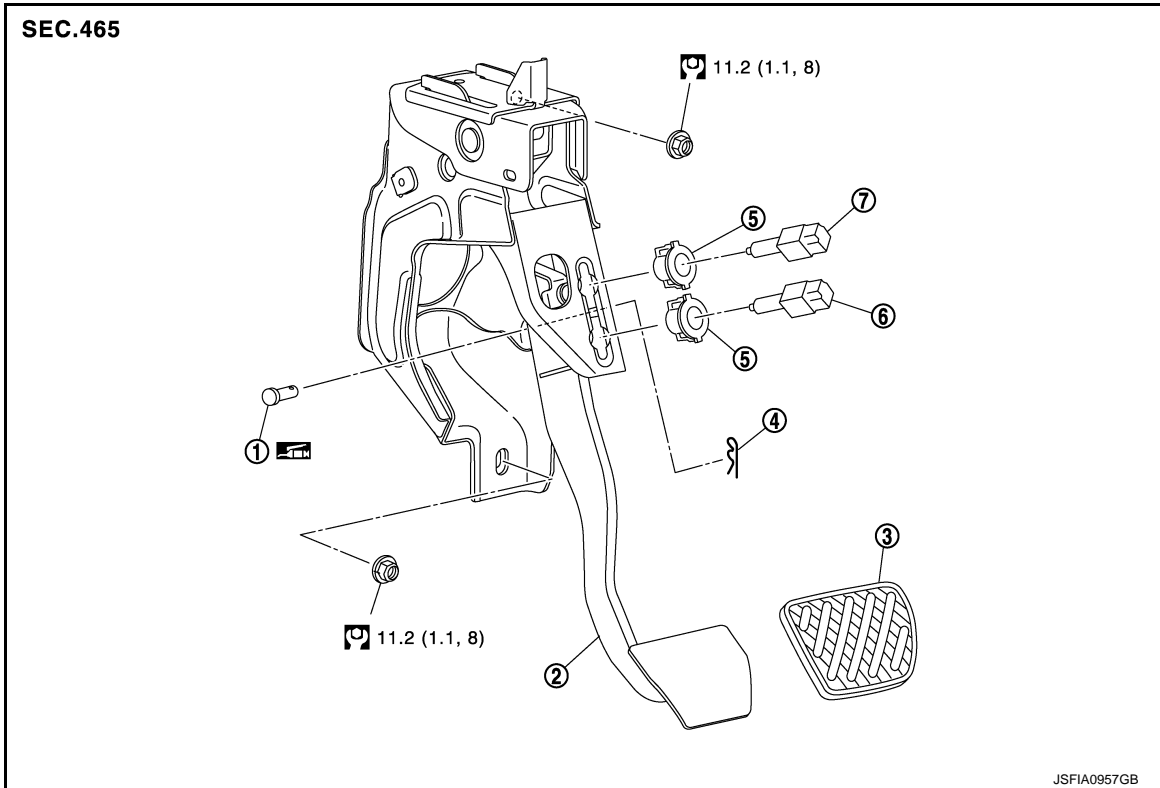

- | | | |
|---------------------|-------------------------|--------------------|
| 1. Clevis pin | 2. Brake pedal assembly | 3. Brake pedal pad |
| 4. Snap pin | 5. Clip | 6. Brake switch |
| 7. Stop lamp switch | | |

: Apply multi-purpose grease.

: N·m (kg·m, ft·lb)

Removal and Installation

INFOID:000000011326116

REMOVAL

1. Remove instrument lower panel LH. Refer to [IP-14, "Removal and Installation"](#).
2. Disconnect the stop lamp switch and the brake switch harness connectors.
3. Rotate the stop lamp switch and the brake switch (1) counter clockwise to remove.

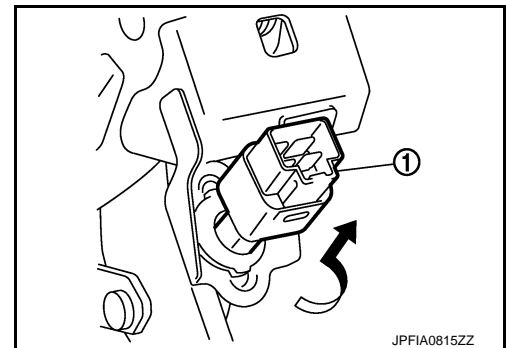

BRAKE PEDAL

< REMOVAL AND INSTALLATION >

4. Remove snap pin (1) and clevis pin (2) from clevis (3) of brake booster.
5. Remove the brake pedal assembly.
CAUTION:
Hold the brake booster and master cylinder assembly so as not to drop out or contact them other parts.
6. Perform inspection after removal. Refer to [BR-21, "Inspection and Adjustment"](#).

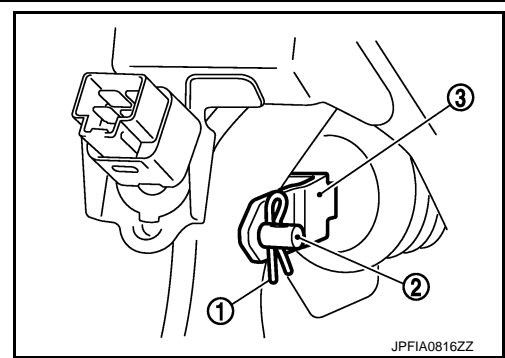

INSTALLATION

Note the following, and install in the reverse order of removal.

- Apply the multi-purpose grease to the clevis pin and the mating faces. (Not necessary if grease has been already applied)

NOTE:

- The clevis pin may be inserted in either direction.
- Perform adjustment after installation. Refer to [BR-21, "Inspection and Adjustment"](#).

Inspection and Adjustment

INFOID:000000011326117

INSPECTION AFTER REMOVAL

- Check for the following items and replace the brake pedal assembly if necessary.
 - Check the brake pedal upper rivet (made by aluminum) (A) for deformation.
 - Check the brake pedal for bend, damage, and cracks on the welded parts.
 - Check the lapping length (D) of sub-bracket (B) and slide plate (C).

D : 6.0 mm (0.236 in) or more

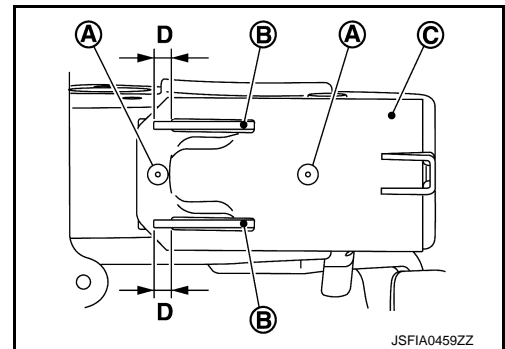

- Check clevis pin and plastic stopper (A) for damage and deformation. If any is found, replace clevis pin.

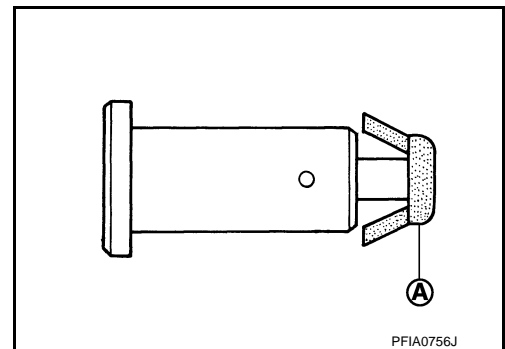

ADJUSTMENT AFTER INSTALLATION

Adjust each item of brake pedal after installing the brake pedal assembly to the vehicle. Refer to [BR-9, "Inspection and Adjustment"](#).

BRAKE PIPING

< REMOVAL AND INSTALLATION >

BRAKE PIPING

FRONT

FRONT : Exploded View

INFOID:000000011326118

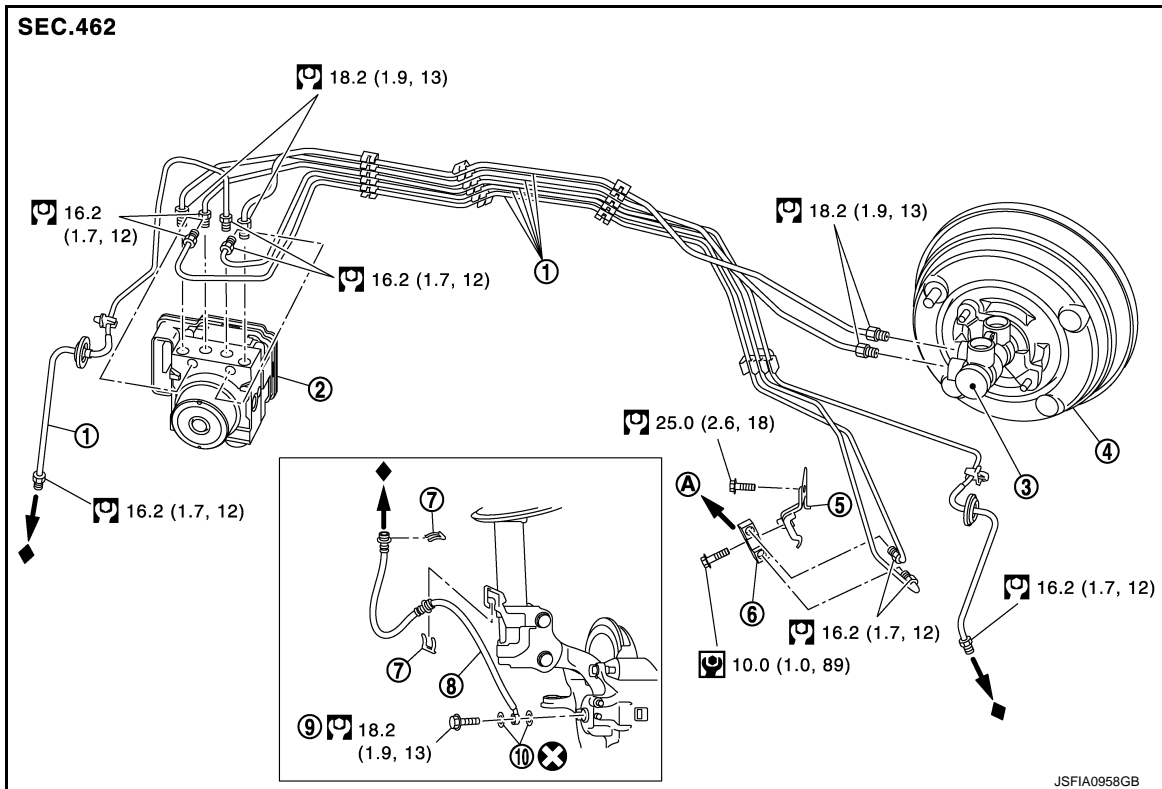

- | | | |
|-------------------|--|-----------------------------|
| 1. Brake tube | 2. ABS actuator and electric unit (control unit) | 3. Master cylinder assembly |
| 4. Brake booster | 5. Connector bracket | 6. Connector |
| 7. Lock plate | 8. Brake hose | 9. Union bolt |
| 10. Copper washer | | |

A. To rear brake tube

: N-m (kg-m, ft-lb)

: N-m (kg-m, in-lb)

: Always replace after every disassembly.

: Indicates that the part is connected at points with same symbol in actual vehicle.

BRAKE PIPING

< REMOVAL AND INSTALLATION >

FRONT : Hydraulic Piping

INFOID:000000011326119

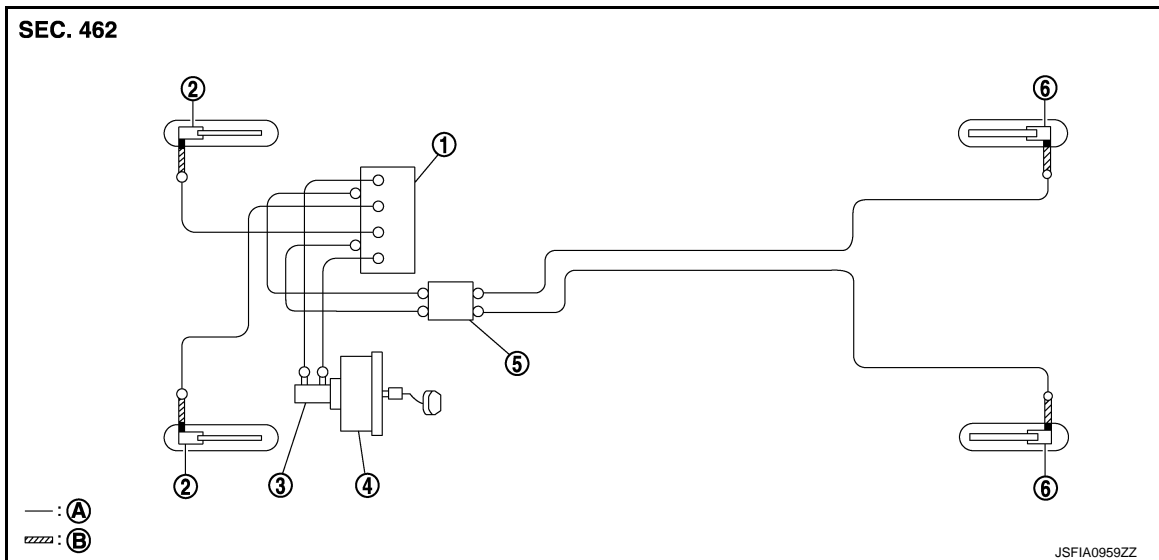

- | | | |
|--|---------------------|-----------------------------|
| 1. ABS actuator and electric unit (control unit) | 2. Front disc brake | 3. Master cylinder assembly |
| 4. Brake booster | 5. Connector | 6. Rear disc brake |
| A. Brake tube | B. Brake hose | |

- : Flare nut
 ■: Union bolt

FRONT : Removal and Installation

INFOID:000000011326120

REMOVAL

CAUTION:

- Never spill or splash brake fluid on painted surfaces. Brake fluid may seriously damage paint. Wipe it off immediately and wash with water if it gets on a painted surface. For brake component parts, never wash them with water.
- Never depress the brake pedal while removing the brake hose or brake tube. If this is not complied with, brake fluid may splash.
- If the brake fluid adheres to the brake caliper assembly and disc rotor, quickly wipe it off.

1. Remove tires with power tool.
2. Drain brake fluid. Refer to [BR-12. "Draining"](#).
3. Loosen the flare nut (1) with a flare nut wrench (A) and separate the brake tube (2) from the brake hose (3).

CAUTION:

- Never scratch the flare nut and the brake tube.
- Never bend sharply, twist or strongly pull out the brake hoses and tubes.
- Cover open end of brake tubes and hoses when disconnecting to prevent entrance of dirt.

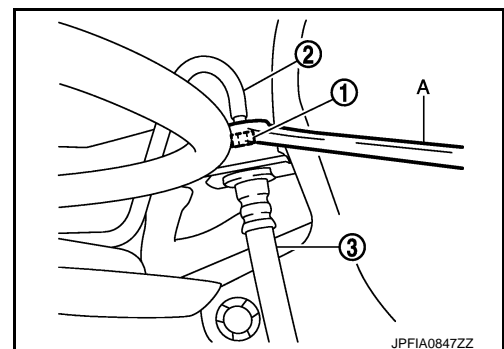

BRAKE PIPING

< REMOVAL AND INSTALLATION >

4. Remove the union bolt (1) and copper washers (2), and remove the brake hose (3) from the brake caliper assembly.
5. Remove the lock plate (4) and remove the brake hose.

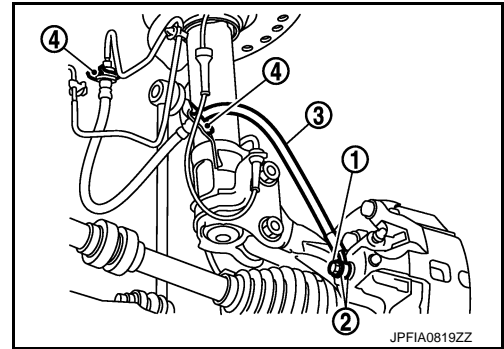

INSTALLATION

CAUTION:

- Never spill or splash brake fluid on painted surfaces. Brake fluid may seriously damage paint. Wipe it off immediately and wash with water if it gets on a painted surface. For brake component parts, never wash them with water.
- Never depress the brake pedal while removing the brake hose or brake tube. If this is not complied with, brake fluid may splash.
- If the brake fluid adheres to the brake caliper assembly and disc rotor, quickly wipe it off.

1. Assemble the union bolt (1) and the copper washer (2) to the brake hose.

CAUTION:

Never reuse the copper washer.

2. Align the brake hose L-pin (A) with the brake caliper assembly hole (B), and tighten the union bolt (1) to the specified torque.

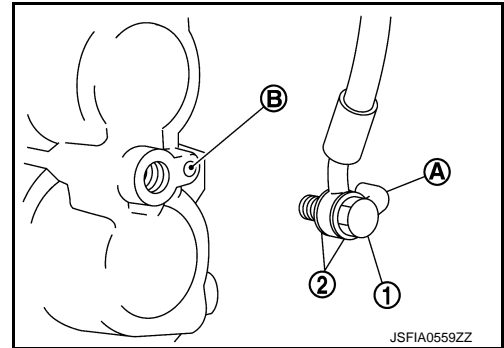

3. Install the brake tube (2) to the brake hose (1), temporarily tighten the flare nut (3) by hand until it does not rotate further, and fix the brake hose to the bracket (5) with the lock plate (4).

CAUTION:

Check that all brake hoses and brake tubes are not twisted and bent.

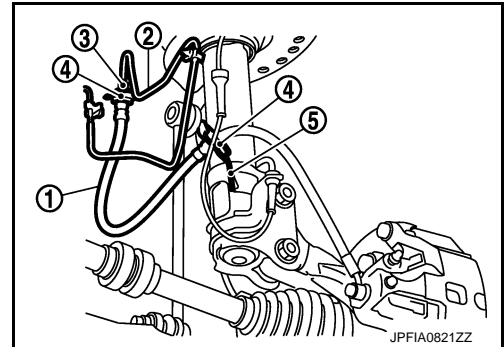

4. Tighten the flare nut to the specified torque with a crowfoot (A) and torque wrench (B).

CAUTION:

Never scratch the flare nut and the brake tube.

5. Perform the air bleeding. Refer to [BR-13, "Bleeding Brake System"](#).
6. Install tires with power tool. Refer to [WT-45, "Removal and Installation"](#).
7. Perform inspection after installation. Refer to [BR-24, "FRONT : Inspection"](#).

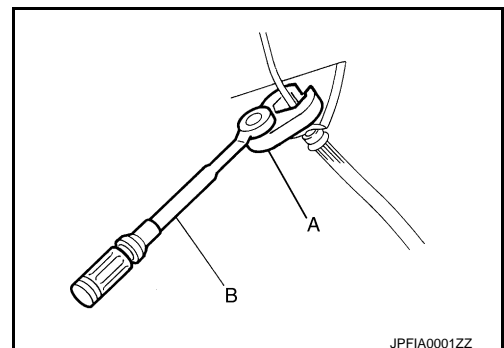

FRONT : Inspection

INSPECTION AFTER INSTALLATION

BRAKE PIPING

< REMOVAL AND INSTALLATION >

1. Check the brake hoses and tubes for the following: no scratches; no twist and deformation; no interference with other components when steering the steering wheel; no looseness at connections.
2. Depress the brake pedal with a force of 785 N (80 kg, 176 lb) and hold down the pedal for approximately 5 seconds with the engine running. Check for any fluid leakage.

CAUTION:

Retighten the applicable connection to the specified torque and repair any abnormal (damaged, worn or deformed) part if any brake fluid leakage is present.

REAR

REAR : Exploded View

INFOID:000000011326122

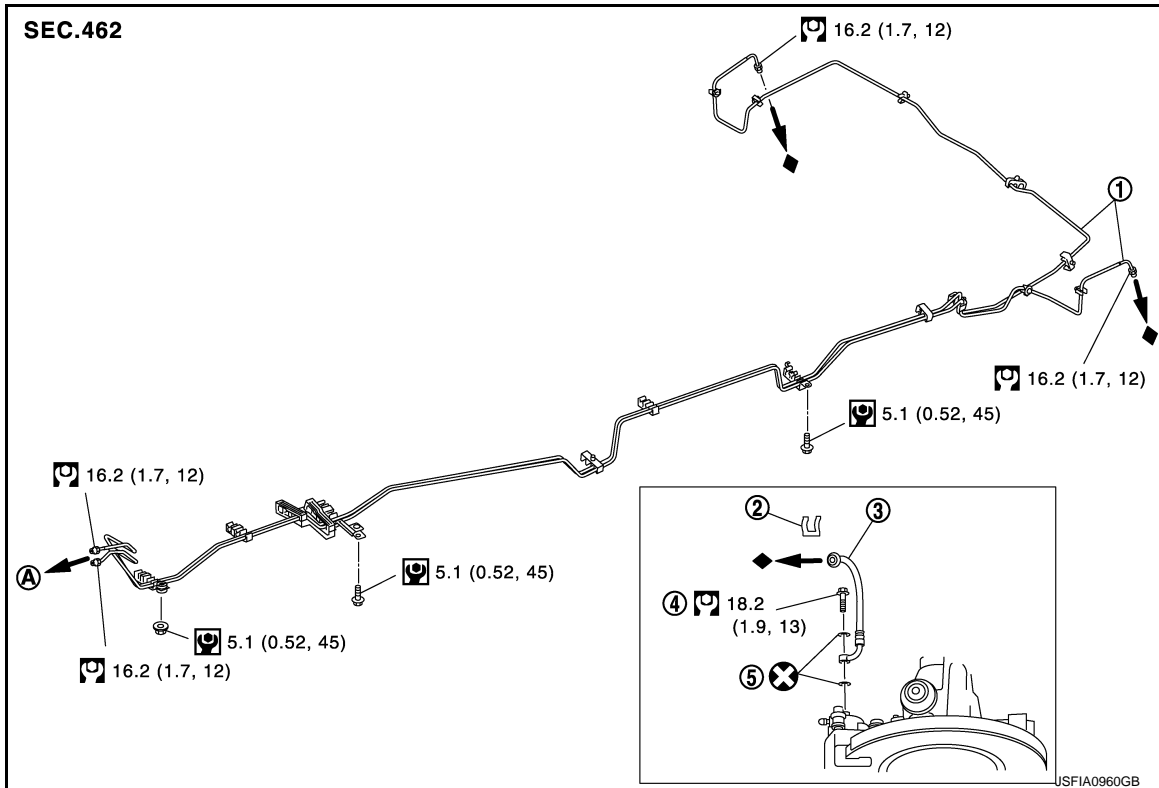

- | | | |
|-----------------|------------------|---------------|
| 1. Brake tube | 2. Lock plate | 3. Brake hose |
| 4. Union bolt | 5. Copper washer | |
| A. To connector | | |

: N·m (kg-m, ft-lb)

: N·m (kg-m, in-lb)

: Always replace after every disassembly.

: Indicates that the part is connected at points with same symbol in actual vehicle.

BRAKE PIPING

< REMOVAL AND INSTALLATION >

REAR : Hydraulic Piping

INFOID:000000011326123

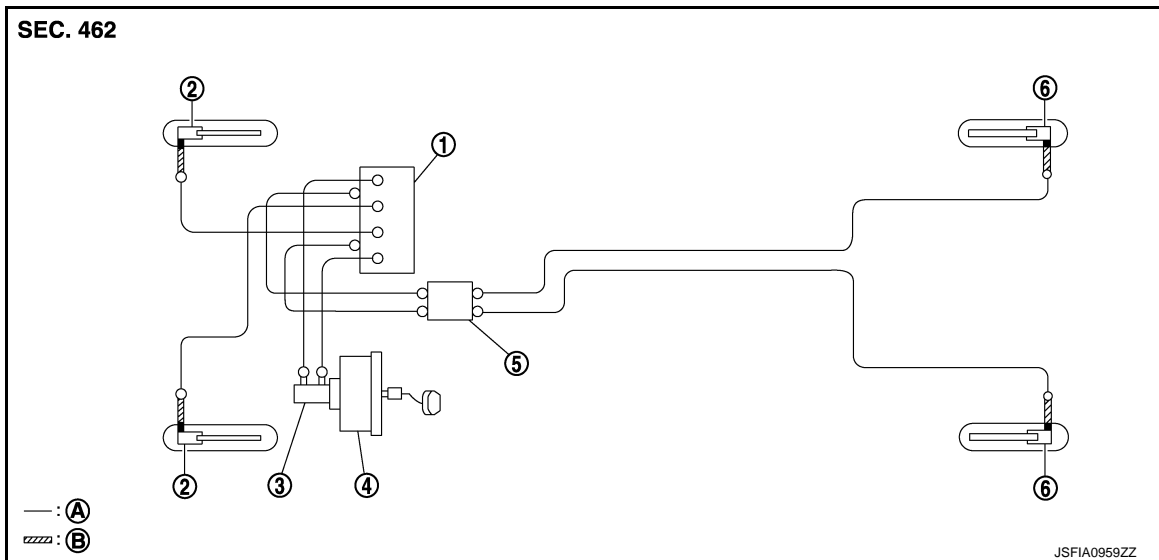

- | | | |
|--|---------------------|-----------------------------|
| 1. ABS actuator and electric unit (control unit) | 2. Front disc brake | 3. Master cylinder assembly |
| 4. Brake booster | 5. Connector | 6. Rear disc brake |
| A. Brake tube | B. Brake hose | |

○: Flare nut

■: Union bolt

REAR : Removal and Installation

INFOID:000000011326124

REMOVAL

CAUTION:

- Never spill or splash brake fluid on painted surfaces. Brake fluid may seriously damage paint. Wipe it off immediately and wash with water if it gets on a painted surface. For brake component parts, never wash them with water.
- Never depress the brake pedal while removing the brake hose or brake tube. If this is not complied with, brake fluid may splash.
- If the brake fluid adheres to the brake caliper assembly and disc rotor, quickly wipe it off.

1. Remove tires with power tool.
2. Drain brake fluid. Refer to [BR-12, "Draining"](#).
3. Loosen the flare nut (1) with a flare nut wrench (A) and separate the brake tube (2) from the brake hose (3).

CAUTION:

- Never scratch the flare nut and the brake tube.
- Never bend sharply, twist or strongly pull out the brake hoses and tubes.
- Cover open end of brake tubes and hoses when disconnecting to prevent entrance of dirt.

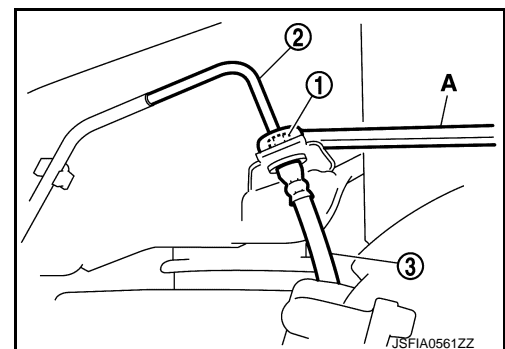

BRAKE PIPING

< REMOVAL AND INSTALLATION >

4. Remove the union bolt (1) and copper washers (2), and remove the brake hose (3) from the brake caliper assembly.
5. Remove the lock plate (4), and remove brake hose.

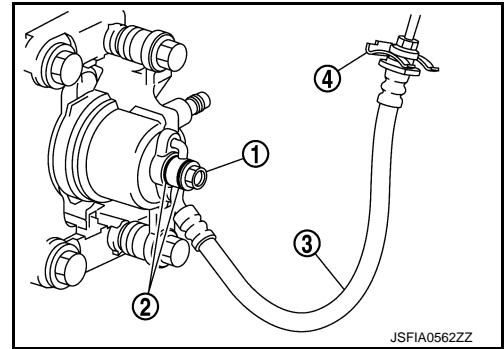

INSTALLATION

CAUTION:

- Never spill or splash brake fluid on painted surfaces. Brake fluid may seriously damage paint. Wipe it off immediately and wash with water if it gets on a painted surface. For brake component parts, never wash them with water.
- Never depress the brake pedal while removing the brake hose or brake tube. If this is not complied with, brake fluid may splash.
- If the brake fluid adheres to the brake caliper assembly and disc rotor, quickly wipe it off.

1. Assemble the union bolt (1) and the copper washer (2) to the brake hose.

CAUTION:

Never reuse the copper washer.

2. Align the brake hose L-pin (A) with the brake caliper assembly hole (B), and tighten the union bolt to the specified torque.

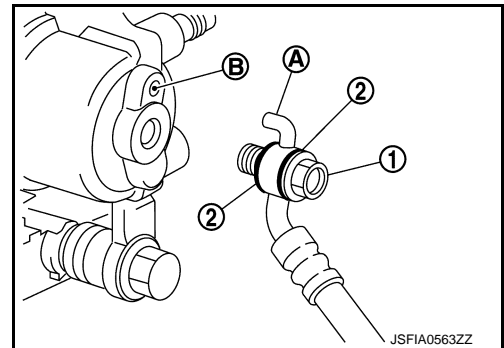

3. Install the brake tube (2) to the brake hose (1), temporarily tighten the flare nut (3) by hand until it does not rotate further, and fix the brake hose with the lock plate (4).

CAUTION:

Check that all brake hose and brake tube are not twisted and bent.

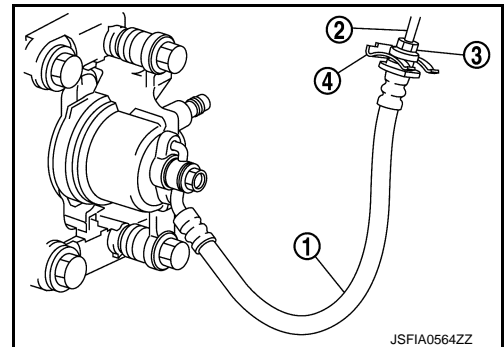

4. Tighten the flare nut to the specified torque with a crowfoot (A) and torque wrench (B).

CAUTION:

Never scratch the flare nut and the brake tube.

5. Perform the air bleeding. Refer to [BR-13, "Bleeding Brake System"](#).
6. Install tires with power tool. Refer to [WT-45, "Removal and Installation"](#).
7. Perform inspection after installation. Refer to [BR-27, "REAR : Inspection"](#).

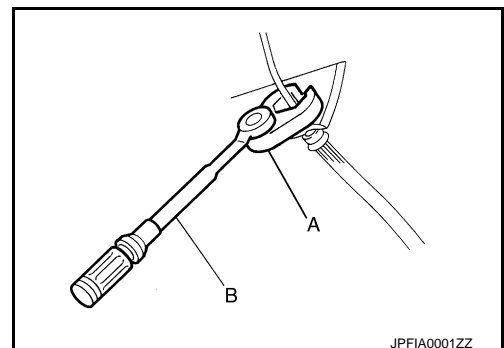

REAR : Inspection

INFOID:000000011326125

INSPECTION AFTER INSTALLATION

BRAKE PIPING

< REMOVAL AND INSTALLATION >

1. Check the brake hoses and tubes for the following: no scratches; no twist and deformation; no looseness at connections.
2. Depress the brake pedal with a force of 785 N (80 kg, 176 lb) and hold down the pedal for approximately 5 seconds with the engine running. Check for any fluid leakage.

CAUTION:

Retighten the applicable connection to the specified torque and repair any abnormal (damaged, worn or deformed) part if any brake fluid leakage is present.

BRAKE MASTER CYLINDER

< REMOVAL AND INSTALLATION >

BRAKE MASTER CYLINDER

Exploded View

INFOID:000000011326126

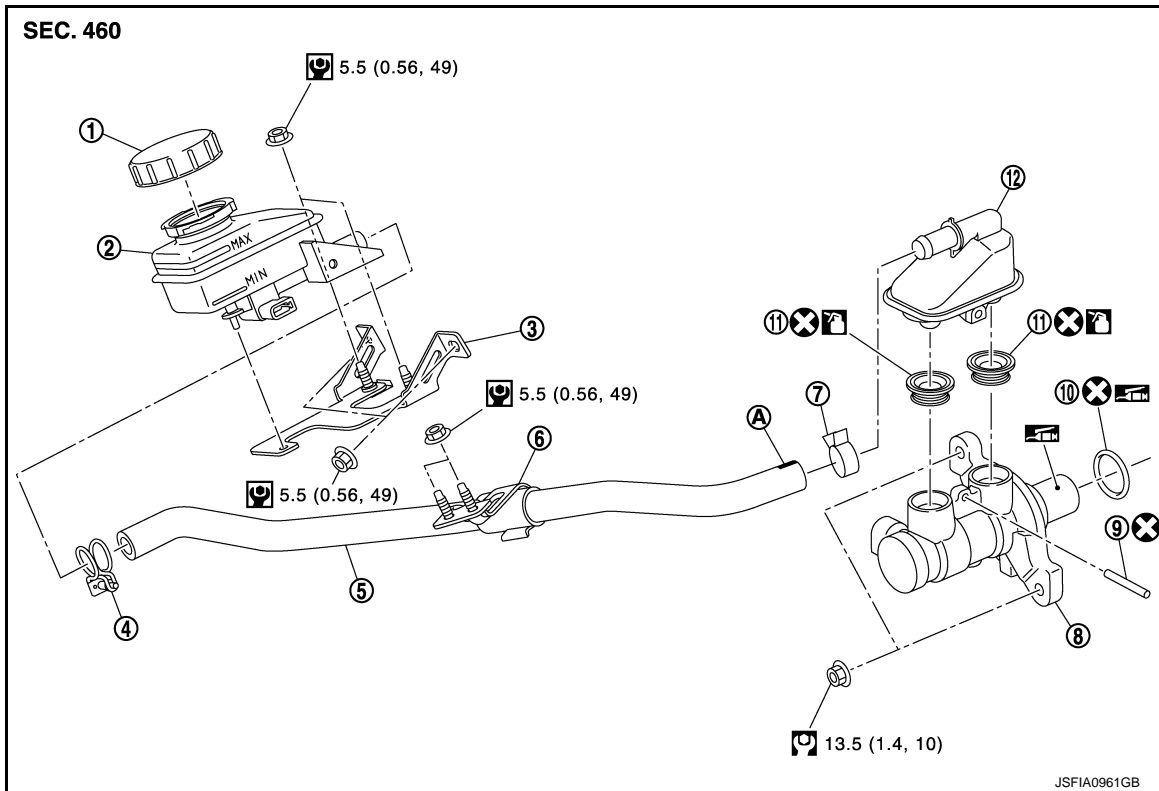

- | | | |
|------------------|-------------------|---------------------------|
| 1. Reservoir cap | 2. Reservoir tank | 3. Reservoir tank bracket |
| 4. Clamp | 5. Hose | 6. Bracket |
| 7. Clamp | 8. Cylinder body | 9. Pin |
| 10. O-ring | 11. Grommet | 12. Sub tank |
| A. Paint mark | | |

: Apply polyglycol ether based lubricant.

: Apply brake fluid.

: N·m (kg-m, ft-lb)

: N·m (kg-m, in-lb)

: Always replace after every disassembly.

Removal and Installation

INFOID:000000011326127

REMOVAL

CAUTION:

- Never spill or splash brake fluid on painted surfaces. Brake fluid may seriously damage paint. Wipe it off immediately and wash with water if it gets on a painted surface. For brake component parts, never wash them with water.
- Never depress the brake pedal while removing the brake tube. If this is not complied with, brake fluid may splash.

1. Perform inspection before removal. Refer to [BR-32, "Inspection"](#).
2. Depress the brake pedal several times to release the vacuum pressure from the brake booster.
3. Drain brake fluid. Refer to [BR-12, "Draining"](#).
4. Disconnect the brake fluid level switch harness connector.

BRAKE MASTER CYLINDER

< REMOVAL AND INSTALLATION >

5. Remove reservoir tank, bracket and hose.
6. Remove air duct and air cleaner case. Refer to [EM-27, "Removal and Installation"](#).
7. Separate the brake tube from master cylinder assembly with a flare nut wrench (A).

CAUTION:

Never scratch the flare nut and the brake tube.

8. Remove the master cylinder assembly.

CAUTION:

- Never deform or bend the brake tubes.
- Never depress the brake pedal after the master cylinder assembly is removed.

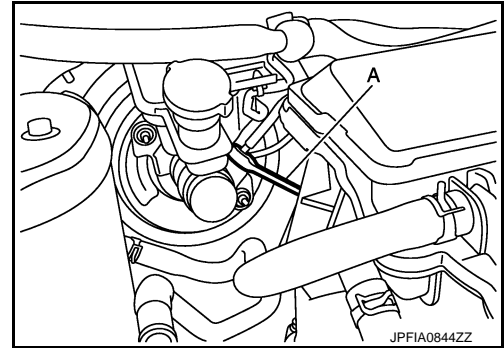

- The piston (A) of the master cylinder assembly is exposed. Never damage it when removing the master cylinder.
- The piston may drop off when pulled out strongly. Never hold the piston. Hold the cylinder body when handling the master cylinder assembly.

9. Remove the O-ring.

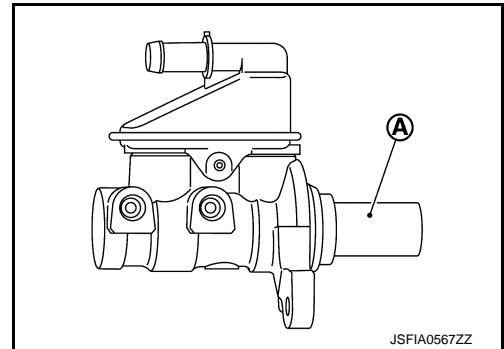

INSTALLATION

Note the following, and install in the reverse order of removal.

- Never spill or splash brake fluid on painted surfaces. Brake fluid may seriously damage paint. Wipe it off immediately and wash with water if it gets on a painted surface. For brake component parts, never wash them with water.
- Never depress the brake pedal while removing the brake tube. If this is not complied with, brake fluid may splash.
- Never depress the brake pedal after the master cylinder assembly is removed.
- Apply polyglycol ether based lubricant to the brake booster [see (A) in the figure] when installing the master cylinder assembly to the brake booster.

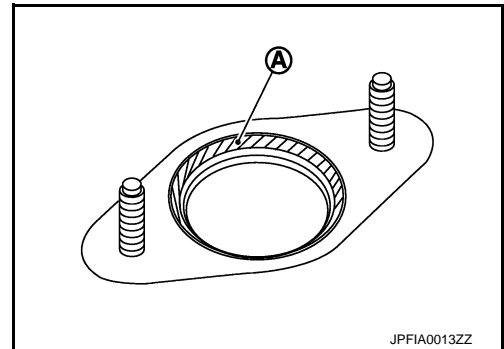

- The piston (A) of the master cylinder assembly is exposed. Never damage it when handling the master cylinder.
- Check that no dirt and dust are present on the piston before installation. Clean it with new brake fluid if necessary.
- The piston may drop off when pulled strongly. Never hold the piston. Hold the cylinder body when handling the master cylinder assembly.
- Never reuse the O-ring.
- Never deform or bend the brake tubes.

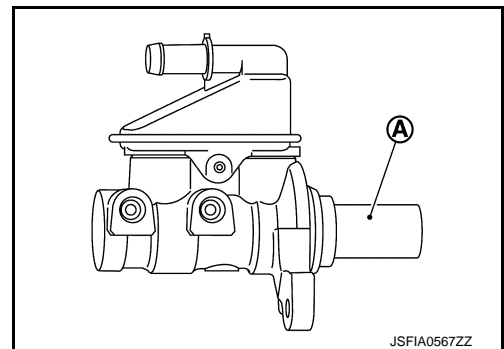

BRAKE MASTER CYLINDER

< REMOVAL AND INSTALLATION >

- Temporarily tighten the brake tube flare nut to the master cylinder assembly by hand. Then tighten it to the specified torque with a crowfoot and torque wrench (A). Refer to [BR-22, "FRONT : Exploded View"](#).

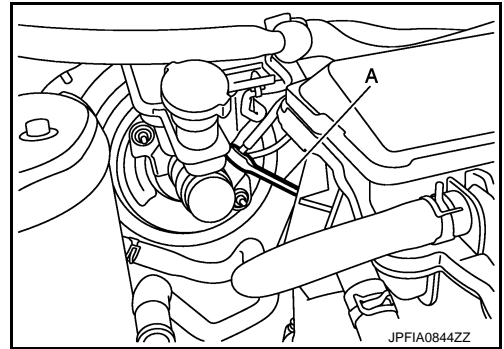

- Align paint mark of hose with sub tank projection (A), and install hose to sub tank.

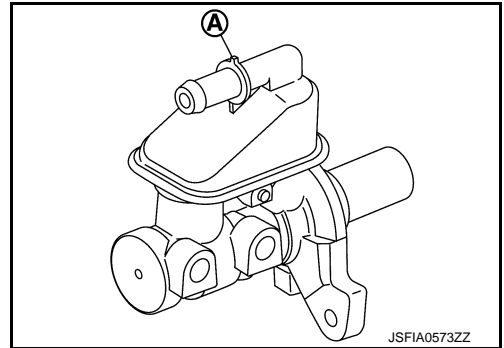

- When installing hose, insert it until its tip reaches the back-end of length (A) or further as show in the figure.

A : 25 mm (0.98 in) or more

- Perform the air bleeding. Refer to [BR-13, "Bleeding Brake System"](#)
- Perform inspection after installation. Refer to [BR-32, "Inspection"](#).

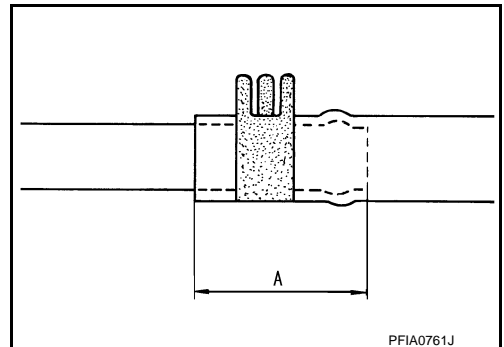

INFOID:000000011326128

Disassembly and Assembly

DISASSEMBLY

CAUTION:

- Never disassemble the cylinder body.
- Remove the sub tank only when necessary.
- Never drop the when installing. The parts must not be reused if they are dropped.

- Fix the master cylinder assembly to a vise.

CAUTION:

- Always set copper plates or cloth between vise grips when fixing the cylinder body to a vise.
- Never overtighten the vise.

- Remove the sub tank mounting pin with a pin punch (A) [4 mm (0.16 in)].
- Remove the sub tank and grommet from the cylinder body.

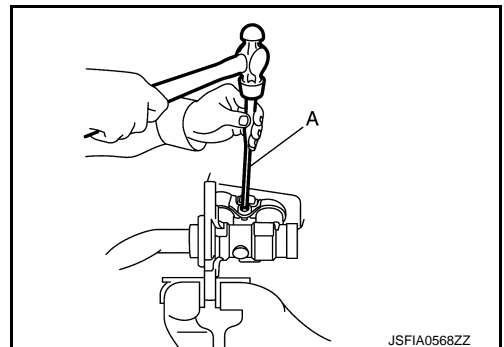

BRAKE MASTER CYLINDER

< REMOVAL AND INSTALLATION >

ASSEMBLY

CAUTION:

- Never use mineral oils such as kerosene or gasoline and rubber grease during the cleaning and assembly process.
- Never allow foreign matter (e.g. dust) and oils other than brake fluid to enter the sub tank.
- Never drop the when installing. The parts must not be reused if they are dropped.

1. Apply new brake fluid to the grommet and install it to the cylinder body.

CAUTION:

Never reuse the grommets.

2. Install the sub tank to the cylinder body.
3. Fix the cylinder body to a vise.

CAUTION:

- Place the sub tank with the chamfered pin hole (←) facing up.
- Always set copper plates or cloth between vise grips when fixing the cylinder body to a vise.
- Never overtighten the vise.

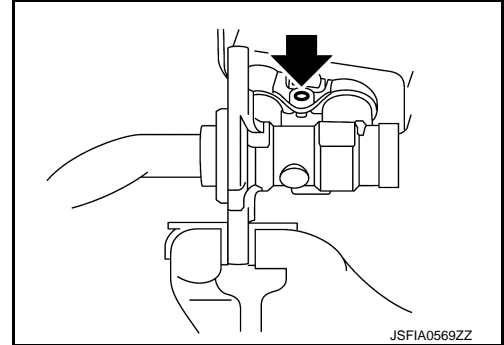

4. Tilt the sub tank so that a mounting pin can be inserted. Insert a mounting pin with a pin punch (A) [4 mm (0.16 in)]. Return the sub tank to the horizontal position. Insert another mounting pin into the pin hole on the opposite side in the same manner after the mounting pin passes through the cylinder body pin hole.

CAUTION:

Never reuse the pin.

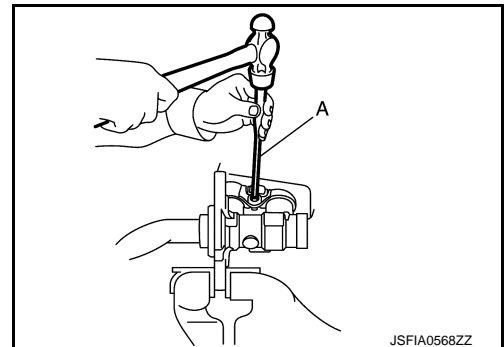

Inspection

INFOID:000000011326129

INSPECTION BEFORE REMOVAL

Check the brake fluid level switch. Refer to [BRC-91, "Component Inspection"](#).

INSPECTION AFTER INSTALLATION

Check the following items and replace if necessary.

- Check the master cylinder for deformation, twist, contact with other parts or looseness of connection.
- Check for fluid leakage from connection. Refer to [BR-24, "FRONT : Inspection"](#).

CAUTION:

If the fluid leakage is present, retighten to the specified torque. Replace if necessary.

BRAKE BOOSTER

< REMOVAL AND INSTALLATION >

BRAKE BOOSTER

Exploded View

INFOID:000000011326130

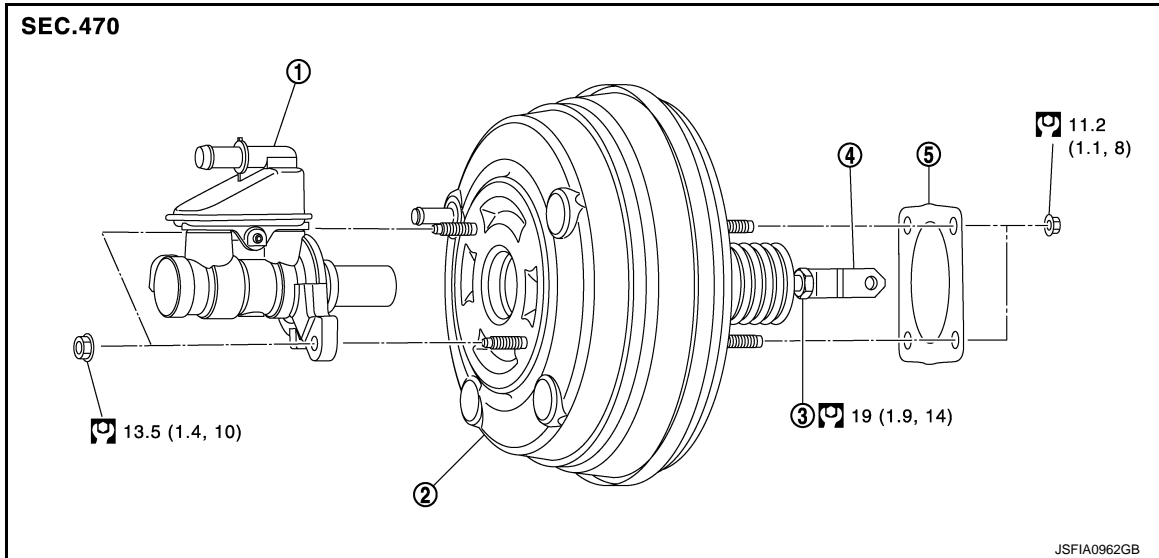

1. Master cylinder assembly
2. Brake booster
3. Lock nut
4. Clevis
5. Gasket

: N·m (kg-m, ft-lb)

Removal and installation

INFOID:000000011326131

REMOVAL

1. Perform inspection before removal. Refer to [BR-34, "Inspection and Adjustment"](#).
2. Remove brake master cylinder assembly. Refer to [BR-29, "Removal and Installation"](#).
3. Remove intelligent key warning buzzer. Refer to [DLK-484, "Removal and Installation"](#).
4. Remove vacuum hose from brake booster. Refer to [BR-35, "Removal and Installation"](#).
5. Remove snap pin (1) and clevis pin (2). Refer to [BR-20, "Exploded View"](#).
6. Remove nuts on brake booster and brake pedal assembly.
CAUTION:
Hold the brake booster so as to avoid dropping out.
7. Remove brake booster.
CAUTION:
Never deform or bend the brake tubes.
NOTE:
If removing brake booster is difficult, remove clevis from brake booster.
8. Perform inspection after removal. Refer to [BR-34, "Inspection and Adjustment"](#).

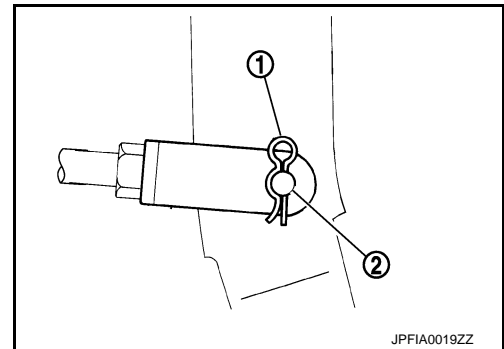

INSTALLATION

CAUTION:

Never spill or splash brake fluid on painted surfaces. Brake fluid may seriously damage paint. Wipe it off immediately and wash with water if it gets on a painted surface.

Note the following, and install in the reverse order of removal.

- Be careful not to damage brake booster stud bolt threads. If brake booster is tilted during installation, the dash panel may damage the threads.
- Never deform or bend the brake tubes when installing the brake booster.
- Always use a gasket between the brake booster and the dash panel.

BRAKE BOOSTER

< REMOVAL AND INSTALLATION >

- Replace the clevis pin if it is damaged. Refer to [BR-21, "Inspection and Adjustment"](#).
- Perform the air bleeding. Refer to [BR-13, "Bleeding Brake System"](#).
- Check each item of brake pedal. Adjust it if the measurement value is not the standard. Refer to [BR-9, "Inspection and Adjustment"](#).

Inspection and Adjustment

INFOID:000000011326132

INSPECTION BEFORE REMOVAL

Air Tight

CAUTION:

Check the air tight condition when the master cylinder and the brake booster is installed.

1. Check the air tight use a handy vacuum pump.

At vacuum of -66.7 kPa (-500 mmHg, -19.69 inHg) : Vacuum should decrease within 3.3 kPa (24.8 mmHg, 0.98 inHg) for 15 seconds.

2. If the air tight condition cannot be maintained, perform the following operation.
 - a. Check the no dirt and dust are present on the brake booster and brake master cylinder mating faces. Clean it if necessary.
 - b. Check the O-ring on the master cylinder. If anything is found, replace the O-ring. Refer to [BR-29, "Removal and Installation"](#).
 - c. Check the air tight condition again. If the condition still cannot be maintained, replace the brake booster.

INSPECTION AFTER REMOVAL

Input Rod Length Inspection

1. Loosen the lock nut (1) and adjust the input rod (2) to the specified length (A).

A : Refer to [BR-53, "Brake Booster"](#).

2. Tighten the lock nut to the specified torque.

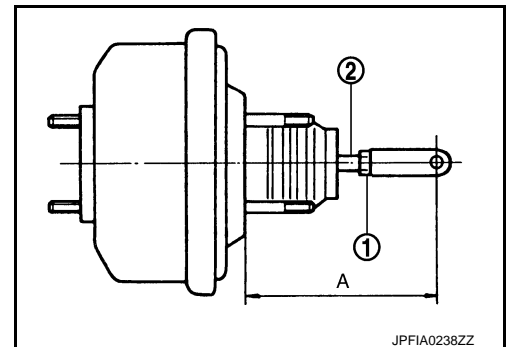

INSPECTION AFTER INSTALLATION

Operation

Depress the brake pedal several times at 5-second intervals with the engine stopped. Start the engine with the brake pedal fully depressed. Check that the clearance between brake pedal and dash lower panel decreases.

NOTE:

A slight impact with a small click may be felt on the pedal when the brake pedal is fully depressed. This is a normal phenomenon due to the brake system operation.

Air Tight

1. Run the engine at idle for 1 minute to apply vacuum to the brake booster, and stop the engine.
2. Depress the brake pedal several times at 5-second intervals until the accumulated vacuum is released to atmospheric pressure. Check that the clearance between brake pedal and dash lower panel gradually increases each time the brake pedal is depressed when performing this operation.
3. Depress the brake pedal with the engine running. Then stop the engine while holding down the brake pedal. Check that the brake pedal stroke does not change after holding down the brake pedal for 30 seconds or more.

ADJUSTMENT AFTER INSTALLATION

Perform the brake pedal adjustment after installing the brake pedal assembly. Refer to [BR-9, "Inspection and Adjustment"](#).

VACUUM LINES

< REMOVAL AND INSTALLATION >

VACUUM LINES

Exploded View

INFOID:000000011326133

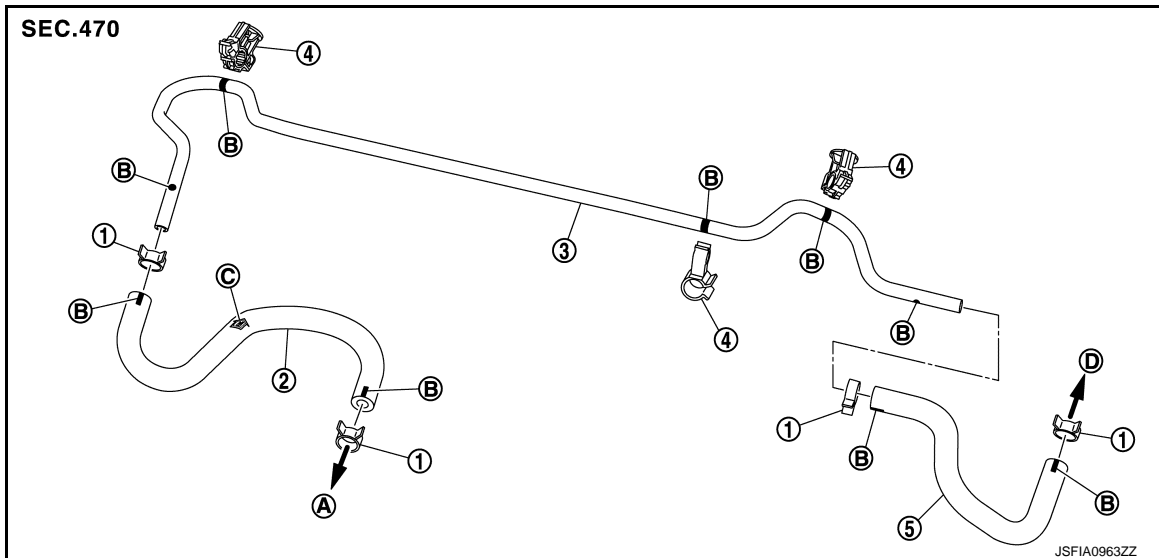

- | | | |
|-----------------------|---------------------------------------|--------------------------------------|
| 1. Clamp | 2. Vacuum hose (check valve built-in) | 3. Vacuum piping |
| 4. Clip | 5. Vacuum hose | |
| A. To intake manifold | B. Paint mark | C. Stamp indicating engine direction |
| D. To brake booster | | |

Removal and Installation

INFOID:000000011326134

REMOVAL

1. Remove air duct and air cleaner case. Refer to [EM-27, "Removal and Installation"](#).
2. Remove the vacuum hose and vacuum piping.
3. Perform inspection after removal. Refer to [BR-35, "Inspection"](#).

INSTALLATION

Note the following, install to the vacuum hose.

- The check valve built-in the vacuum hose must face the right direction, referring to [BR-35, "Exploded View"](#). If the vacuum hose is installed in the wrong direction, the brake booster may not operate normally.
- When installing vacuum hose, insert it until its tip reaches the back-end of length (A) or further as shown in the figure.

CAUTION:

Never use lubricating oil during assembly.

A : 24 mm (0.95 in) or more

- Face the paint mark of vacuum piping (brake booster side) and vacuum hose (intake manifold side) to vehicle front to assemble.
- Face the other paint marks upward to assemble.
- For clamp mounting direction (the orientation of pawl), refer to [BR-35, "Exploded View"](#).
- Install clip to the correct position, refer to [BR-35, "Exploded View"](#).

CAUTION:

Both cooler pipe and vacuum piping must be clipped.

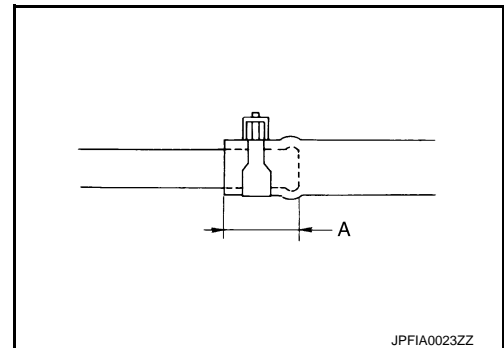

Inspection

INFOID:000000011326135

INSPECTION AFTER REMOVAL

VACUUM LINES

< REMOVAL AND INSTALLATION >

Appearance

Check for correct assembly, damage and deterioration.

Check Valve Airtightness

- Use a handy vacuum pump (A) to check.

When connected to the booster side (B):

Vacuum should decrease within 1.3 kPa (9.8 mmHg, 0.38 inHg) for 15 seconds under a vacuum of -66.7 kPa (-500 mmHg, -19.70 inHg).

When connected to the engine side (C):

Vacuum should not exist.

- Replace vacuum hose if vacuum hose and check valve are malfunctioning.

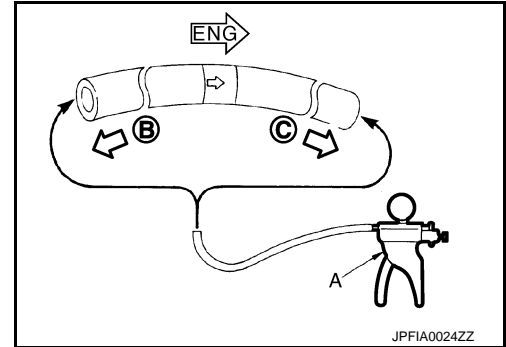

FRONT DISC BRAKE

< REMOVAL AND INSTALLATION >

FRONT DISC BRAKE

BRAKE PAD

BRAKE PAD : Exploded View

INFOID:000000011326136

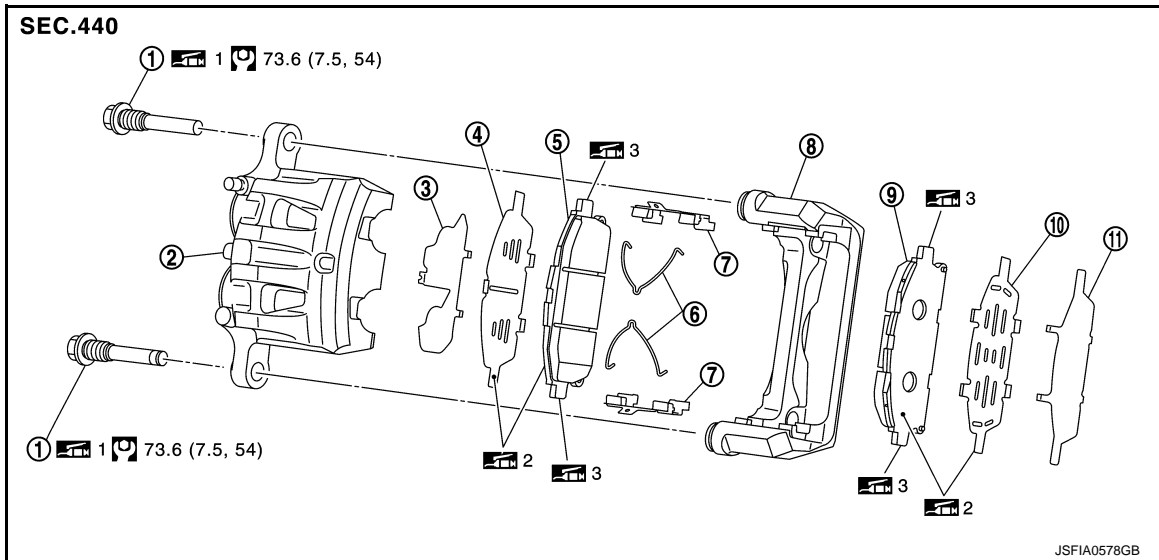

- | | | |
|---------------------|-------------------------------------|----------------------|
| 1. Sliding pin bolt | 2. Cylinder body | 3. Inner shim cover |
| 4. Inner shim | 5. Inner pad (with pad wear sensor) | 6. Pad return spring |
| 7. Pad retainer | 8. Torque member | 9. Outer pad |
| 10. Outer shim | 11. Outer shim cover | |

1: Apply rubber grease.

2: Apply MOLYKOTE® AS880N or silicone-based grease.

3: Apply MOLYKOTE® 7439 or equivalent.

: N-m (kg-m, ft-lb)

Molykote is a registered trademark of Dow Corning Corporation.

BRAKE PAD : Removal and Installation

INFOID:000000011326137

REMOVAL

WARNING:

Since dust covering the front brake has an affect on human body, the dust must be removed with a dust collector. Never splatter the dust with an air blow gun.

CAUTION:

- Never depress the brake pedal while removing the brake pads because the piston may pop out.
- If the brake fluid or grease adheres to the disc rotor or the cylinder body, quickly wipe it off.

1. Remove tires with power tool.
2. Remove sliding pin bolt (lower side) from cylinder body.

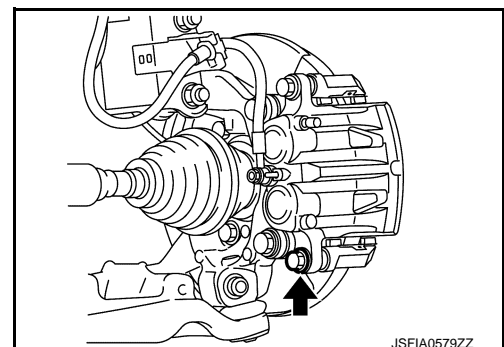

FRONT DISC BRAKE

< REMOVAL AND INSTALLATION >

- Suspend the cylinder body with suitable wire so that the brake hose will not stretch.
- Remove pad return spring.
CAUTION:
Never deform the pad return spring.
- Remove the brake pads from the torque member.

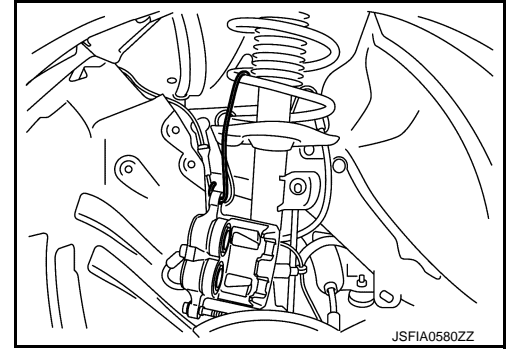

CAUTION:

- Never deform the pad retainer (2) when removing the pad retainer from the torque member (1).
 - Never damage the piston boot.
 - Never drop the brake pads, shims, and the shim covers.
 - Remember each position of the removed brake pads.
- Perform inspection after removal. Refer to [BR-39, "BRAKE PAD : Inspection"](#).

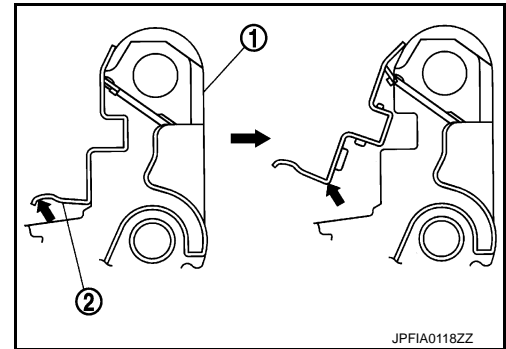

INSTALLATION

WARNING:

Since dust covering the front brake has an affect on human body, the dust must be removed with a dust collector. Never splatter the dust with an air blow gun.

CAUTION:

- Never depress the brake pedal while removing the brake pads or the cylinder body because the piston may pop out.
- If the brake fluid or grease adheres to the disc rotor or the cylinder body, quickly wipe it off.

- Install the pad retainers (1) to the torque member (2) if the pad retainers has been removed.

CAUTION:

- Securely assemble the pad retainers so that it will not be lifted up from the torque member.
- Never deform the pad retainers.

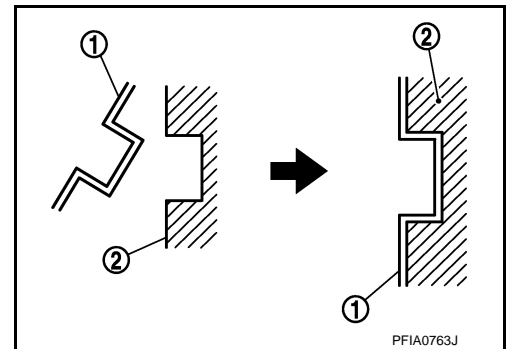

- Apply MOLYKOTE® AS880N or silicone-based grease to the mating faces (A) between the brake pads and the shims, and install the shims and shim covers to the brake pads.

CAUTION:

Always replace the shim and shim cover together when replacing the brake pad.

Molykote is a registered trademark of Dow Corning Corporation.

- Apply MOLYKOTE® 7439 or equivalent to the mating faces (B) between the brake pads and the pad retainers.
- Install the brake pads to the torque member.

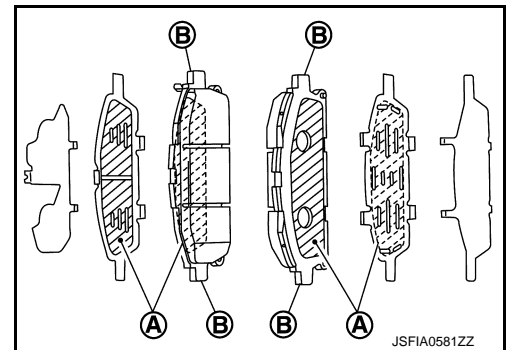

FRONT DISC BRAKE

< REMOVAL AND INSTALLATION >

5. Install the pad return spring (1) to the brake pad (2).

CAUTION:

- Never deform the pad return spring.
- Correctly insert the pad return spring in to the pad return spring hole on the brake pad.

6. Install cylinder body to torque member.

CAUTION:

- Never damage the piston boot.
- When replacing brake pad with new one, check a brake fluid level in the reservoir tank because brake fluid returns to master cylinder reservoir tank when pressing piston in.

NOTE:

Use a disc brake piston tool to easily press piston.

7. Apply rubber grease to sliding pin bolt (lower side), and install the sliding pin bolt (lower side) and tighten it to the specified torque.
8. Depress the brake pedal several times to check that no drag feel is present for the front disc brake. Refer to [BR-39, "BRAKE PAD : Inspection"](#).
9. Install tires with power tool. Refer to [WT-45, "Removal and Installation"](#).

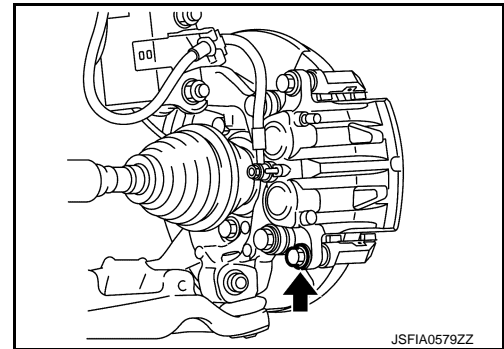
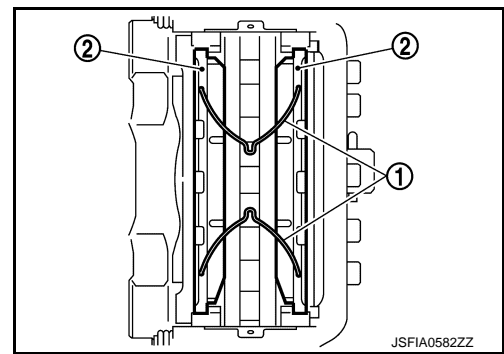

BRAKE PAD : Inspection

INFOID:000000011326138

INSPECTION AFTER REMOVAL

- Replace the shims and the shim covers if rust is excessively attached.
- Eliminate rust on the pad retainers and the torque member. Replace them if rust is excessively attached.

INSPECTION AFTER INSTALLATION

- Check a drag of front disc brake. If any drag is found, follow the procedure described below.
 1. Remove brake pads. Refer to [BR-37, "BRAKE PAD : Removal and Installation"](#).
 2. Press the pistons. Refer to [BR-37, "BRAKE PAD : Removal and Installation"](#).
 3. Install brake pads. Refer to [BR-37, "BRAKE PAD : Removal and Installation"](#).
 4. Securely depress the brake pedal several times.
 5. Check a drag of front disc brake again. If any drag is found, disassemble the cylinder body and replace if necessary. Refer to [BR-42, "BRAKE CALIPER ASSEMBLY : Disassembly and Assembly"](#)
- Burnish contact surfaces brake pads and disc rotor after refinishing or replacing brake pads, or if a soft pedal occurs at very low mileage. Refer to [BR-16, "BRAKE PAD : Inspection and Adjustment"](#).

BRAKE CALIPER ASSEMBLY

BRAKE CALIPER ASSEMBLY : Exploded View

INFOID:000000011326139

REMOVAL

FRONT DISC BRAKE

< REMOVAL AND INSTALLATION >

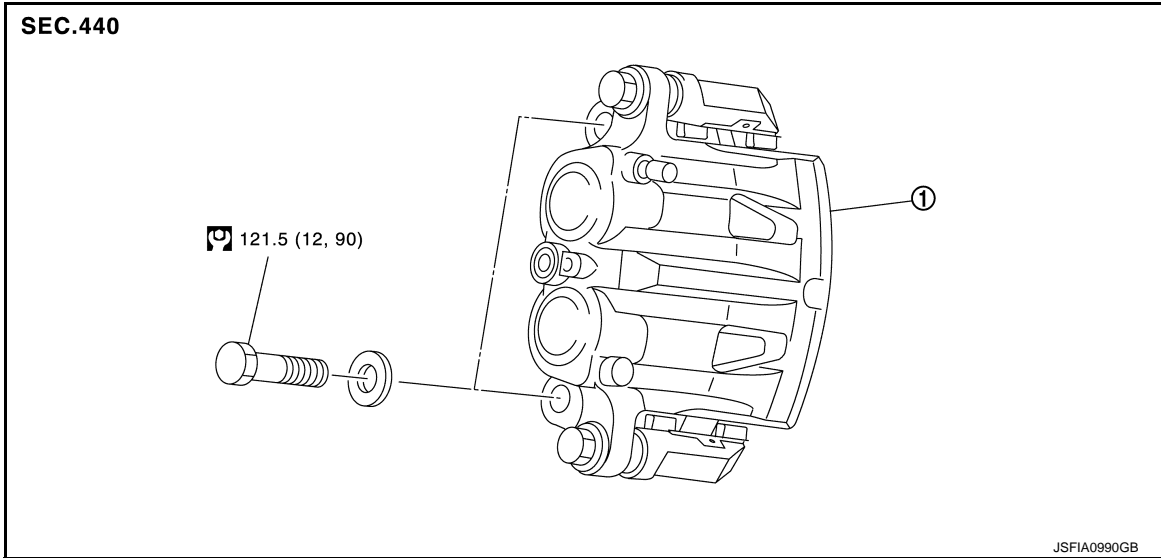

1. Brake caliper assembly

: N-m (kg-m, ft-lb)

DISASSEMBLY

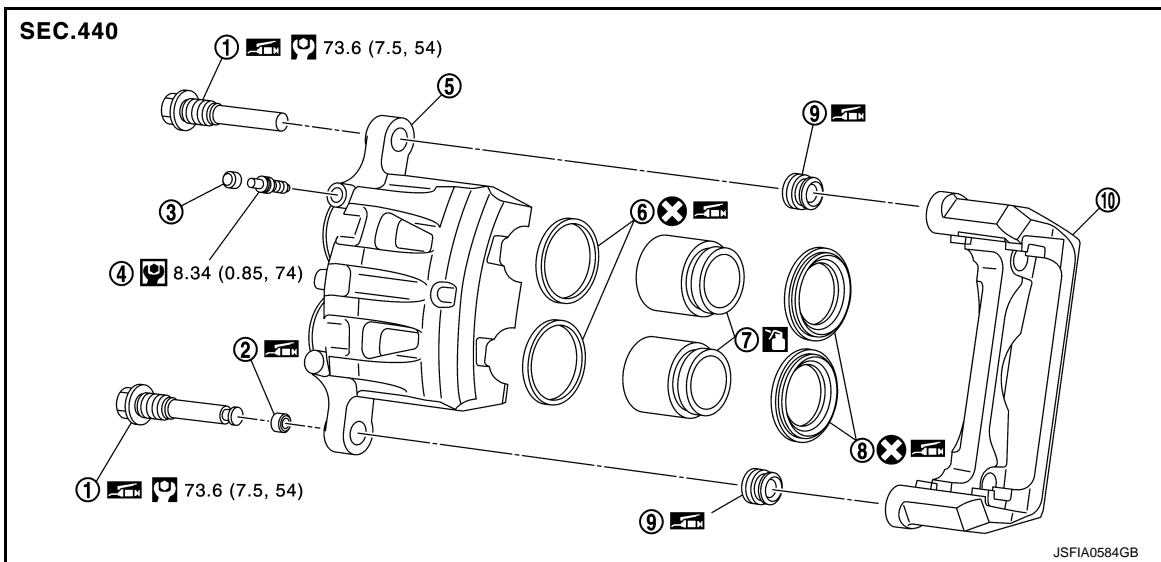

- | | | |
|---------------------|------------------|---------------------|
| 1. Sliding pin bolt | 2. Bushing | 3. Cap |
| 4. Bleeder valve | 5. Cylinder body | 6. Piston seal |
| 7. Piston | 8. Piston boot | 9. Sliding pin boot |
| 10. Torque member | | |

: Apply rubber grease.

: Apply brake fluid.

: N-m (kg-m, ft-lb)

: N-m (kg-m, in-lb)

: Always replace after every disassembly.

FRONT DISC BRAKE

< REMOVAL AND INSTALLATION >

BRAKE CALIPER ASSEMBLY : Removal and Installation

INFOID:000000011326140

REMOVAL

WARNING:

Since dust covering the front brake has an affect on human body, the dust must be removed with a dust collector. Never splatter the dust with an air blow gun.

CAUTION:

- Never spill or splash brake fluid on painted surfaces. Brake fluid may seriously damage paint. Wipe it out immediately and wash with water if it gets on a protect surface. For brake component parts, never wash them with water.
- Never depress the brake pedal while removing the brake hose. If this is not complied with, brake fluid may splash.
- Never drop removed parts.
- If the brake fluid or grease adheres to the disc rotor, quickly wipe it off.

1. Remove tires with power tool.
2. Fix the disc rotor using wheel nuts.
3. Drain brake fluid. Refer to [BR-12, "Draining"](#).
4. Separate brake hose from caliper assembly. Refer to [BR-23, "FRONT : Removal and Installation"](#).
5. Remove torque member mounting bolts, and remove brake caliper assembly.

CAUTION:

Never drop brake pad and caliper assembly.

6. When removing disc rotor. Refer to [FAX-9, "Removal and Installation"](#).

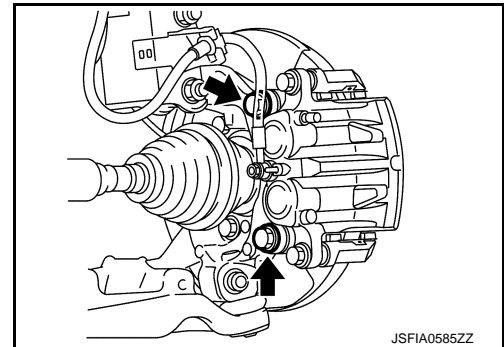

INSTALLATION

WARNING:

Since dust covering the front brake has an affect on human body, the dust must be removed with a dust collector. Never splatter the dust with an air blow gun.

CAUTION:

- Never spill or splash brake fluid on painted surfaces. Brake fluid may seriously damage paint. Wipe it out immediately and wash with water if it gets on a protect surface. For brake component parts, never wash them with water.
- Never depress the brake pedal while removing the brake hose. If this is not complied with, brake fluid may splash.
- Never drop removed parts.
- If the brake fluid or grease adheres to the disc rotor, quickly wipe it off.

1. Install disc rotor. Refer to [FAX-9, "Removal and Installation"](#).
2. Install the brake caliper assembly to the steering knuckle and tighten the torque member mounting bolts to the specified torque.

CAUTION:

Never spill or splash any grease and moisture on the brake caliper assembly mounting face, threads, mounting bolts and washers. Wipe out any grease and moisture.

3. Install brake hose. Refer to [BR-23, "FRONT : Removal and Installation"](#).
4. Perform the air bleeding. Refer to [BR-13, "Bleeding Brake System"](#).
5. Check a drag of front disc brake. If any drag is found, refer to [BR-44, "BRAKE CALIPER ASSEMBLY : Inspection"](#).
6. Install tires with power tool. Refer to [WT-45, "Removal and Installation"](#).

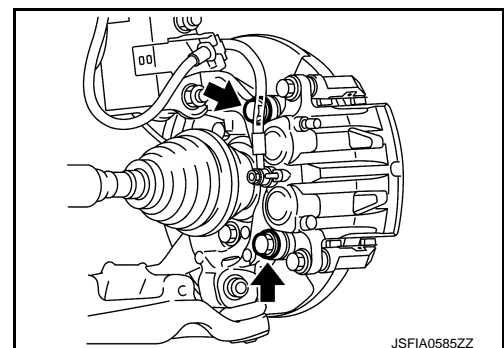

FRONT DISC BRAKE

< REMOVAL AND INSTALLATION >

7. Perform inspection after installation. Refer to [BR-44, "BRAKE CALIPER ASSEMBLY : Inspection"](#).

BRAKE CALIPER ASSEMBLY : Disassembly and Assembly

INFOID:000000011326141

DISASSEMBLY

CAUTION:

Never drop the parts.

NOTE:

Never remove the torque member, brake pad, pad return spring and pad retainers when disassembling and assembling the cylinder body.

1. Remove the sliding pin bolt, and remove the cylinder body from the torque member. Refer to [BR-37, "BRAKE PAD : Removal and Installation"](#).

CAUTION:

Fix the brake pad at suitable tape so that the brake pad will not drop.

2. Remove sliding pin boots from torque member.
3. Remove bushing (1) from sliding pin bolt (2).

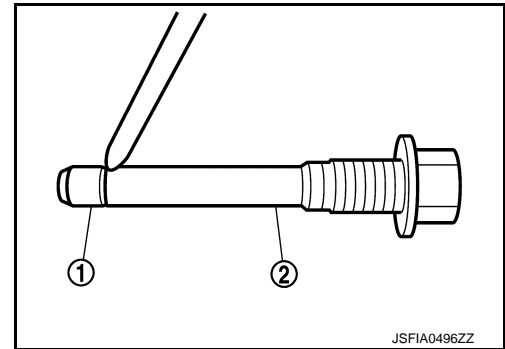

4. Place a wooden block as shown in the figure, and blow air from union bolt mounting hole to remove pistons and piston boots.

CAUTION:

Never get fingers caught in the pistons.

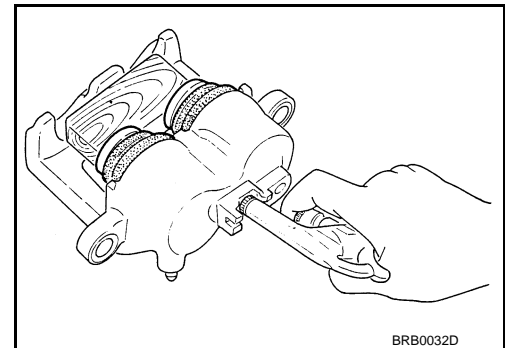

5. Remove piston seal from cylinder body using seal pick tool.

CAUTION:

Be careful not to damage a cylinder inner wall.

6. Remove bleeder valve and cap.
7. Perform inspection after disassembly. Refer to [BR-44, "BRAKE CALIPER ASSEMBLY : Inspection"](#).

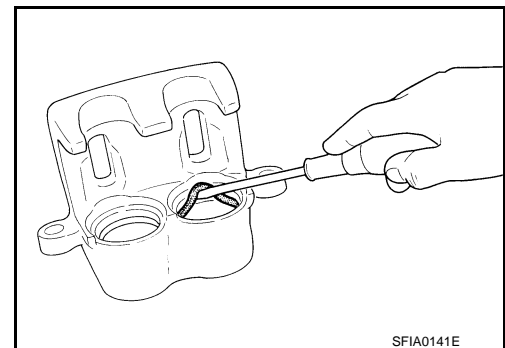

ASSEMBLY

CAUTION:

Never drop the parts.

1. Install bleeder valve and cap.

FRONT DISC BRAKE

< REMOVAL AND INSTALLATION >

2. Apply rubber grease to piston seals (1), and install them to cylinder body.

CAUTION:

Never reuse piston seals.

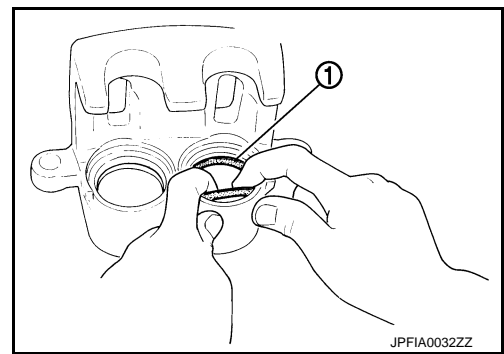

3. Apply rubber grease to piston boots (1). Cover the piston (2) end with piston boot, and then install cylinder side lip on piston boot securely into a groove on cylinder body.

CAUTION:

Never reuse piston boots.

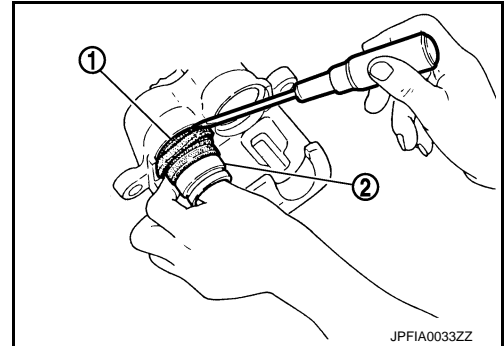

4. Apply new brake fluid to pistons (1). Push piston into cylinder body by hand and push piston boot (2) piston-side lip into the piston groove.

CAUTION:

Press the pistons evenly and vary the pressing point to prevent cylinder inner wall from being rubbed.

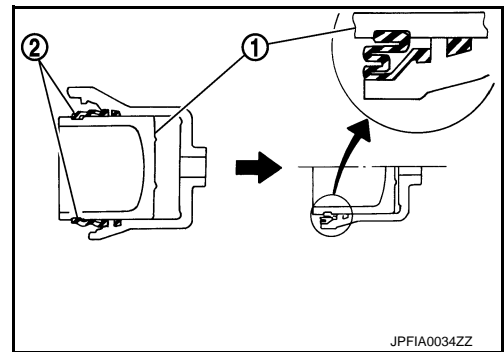

5. Apply rubber grease to mating faces (A) between sliding pin bolt (1) and bushing (2), and install bushing to sliding pin bolt.

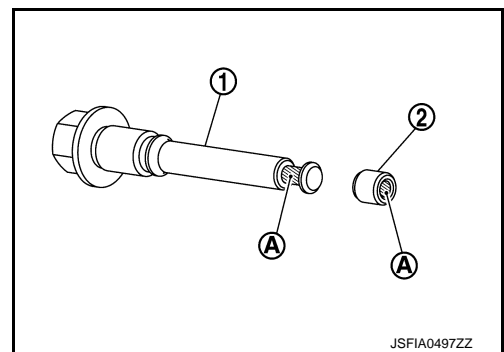

A
B
C
D
E
BR
G
H
I
J
K
L
M
N
O
P

FRONT DISC BRAKE

< REMOVAL AND INSTALLATION >

6. Apply rubber grease to mating faces (A) between sliding pin bolt (1) and sliding pin boot (2), and install sliding pin boot to torque member.
7. Install the cylinder body to torque member, and tighten sliding pin bolts to the specified torque.

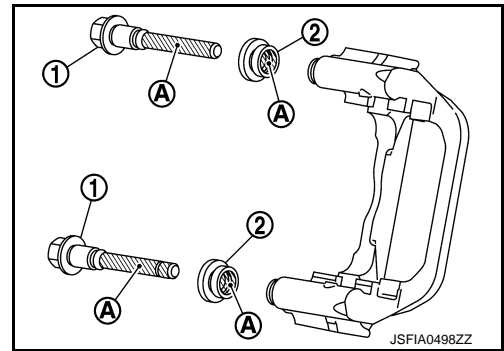

BRAKE CALIPER ASSEMBLY : Inspection

INFOID:000000011326142

INSPECTION AFTER DISASSEMBLY

Check the following items and replace if necessary.

Cylinder Body

Check the inner wall of the cylinder for rust, wear, cracks or damage.

CAUTION:

Always clean with new brake fluid. Never clean with mineral oil such as gasoline and light oil.

Torque Member

Check the torque member for rust, wear, cracks or damage.

Pistons

Check the surface of the piston for rust, wear, cracks or damage.

CAUTION:

A piston sliding surface is plated. Never polish with sandpaper.

Sliding Pin Bolt, Sliding Pin Boot and Bushing

Check the sliding pin bolts, sliding boots and bushing for rust, wear, cracks or damage.

INSPECTION AFTER INSTALLATION

- Check a drag of front disc brake. If any drag is found, follow the procedure described below.
 1. Remove brake pads. Refer to [BR-37, "BRAKE PAD : Removal and Installation"](#).
 2. Press the pistons. Refer to [BR-37, "BRAKE PAD : Removal and Installation"](#).
 3. Install brake pads. Refer to [BR-37, "BRAKE PAD : Removal and Installation"](#).
 4. Securely depress the brake pedal several times.
 5. Check a drag of front disc brake again. If any drag is found, disassemble the cylinder body and replace if necessary. Refer to [BR-42, "BRAKE CALIPER ASSEMBLY : Disassembly and Assembly"](#).
- Burnish contact surface between disc rotor and brake pads after refinishing or replacing disc rotor or brake pad, or if a soft pedal occurs at very low mileage. Refer to [BR-16, "DISC ROTOR : Inspection and Adjustment"](#).

REAR DISC BRAKE

< REMOVAL AND INSTALLATION >

REAR DISC BRAKE

BRAKE PAD

BRAKE PAD : Exploded View

INFOID:000000011326143

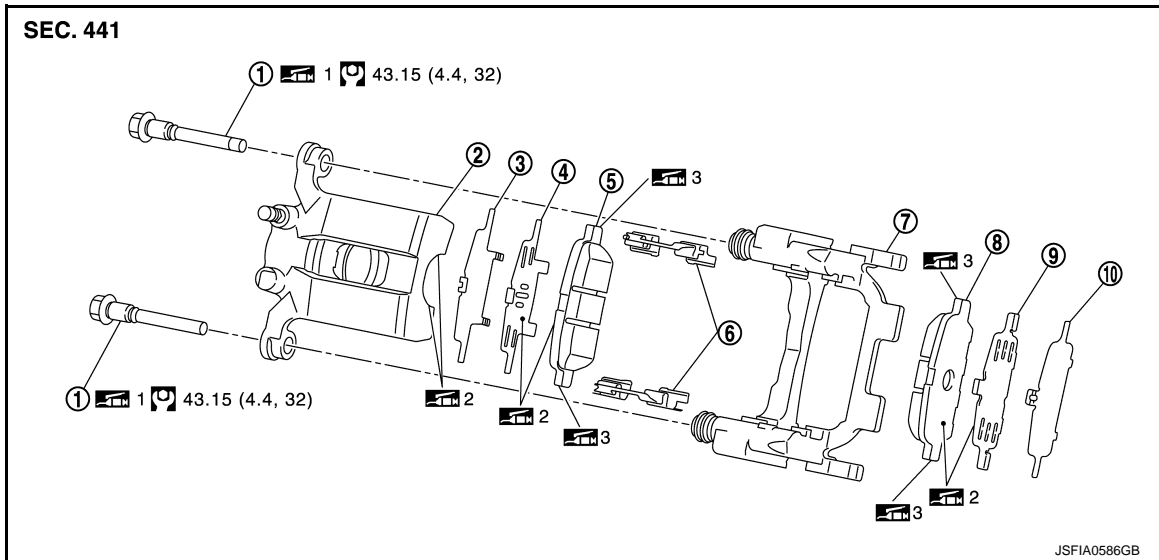

- | | | |
|----------------------|-------------------------------------|---------------------|
| 1. Sliding pin bolt | 2. Cylinder body | 3. Inner shim cover |
| 4. Inner shim | 5. Inner pad (with pad wear sensor) | 6. Pad retainer |
| 7. Torque member | 8. Outer pad | 9. Outer shim |
| 10. Outer shim cover | | |

1 Apply rubber grease.

2: Apply MOLYKOTE® AS880N or silicone-based grease.

3: Apply MOLYKOTE® 7439 or equivalent.

: N-m (kg-m, ft-lb)

Molykote is a registered trademark of Dow Corning Corporation.

BRAKE PAD : Removal and Installation

INFOID:000000011326144

REMOVAL

WARNING:

Since dust covering the rear brake has an affect on human body, the dust must be removed with a dust collector. Never splatter the dust with an air blow gun.

CAUTION:

- Never depress the brake pedal while removing the brake pads because the piston may pop out.
- If the brake fluid or grease adheres to the disc rotor or the cylinder body, quickly wipe it off.

1. Remove tires with power tool.
2. Remove sliding pin bolt (upper side).

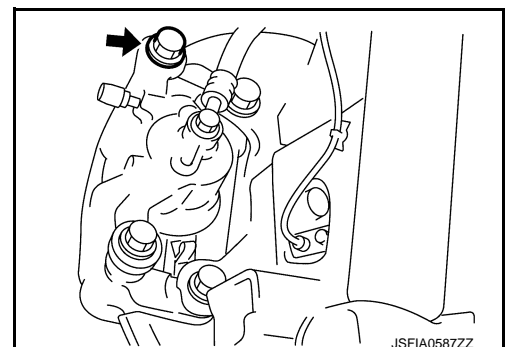

REAR DISC BRAKE

< REMOVAL AND INSTALLATION >

- Suspend the cylinder body with suitable wire so that the brake hose will not stretch.
- Remove the brake pads from the torque member.

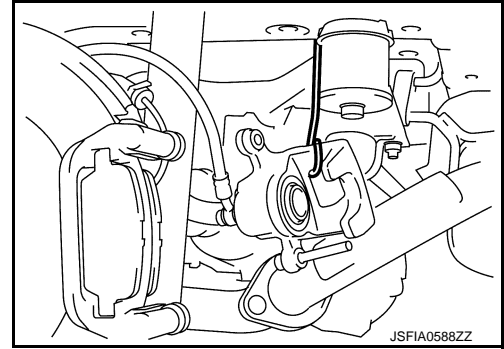

CAUTION:

- Never deform the pad retainer (2) when removing the pad retainer from the torque member (1).
 - Never damage the piston boot.
 - Never drop the brake pads, shims, and the shim covers.
 - Remember each position of the removed brake pads.
- Perform inspection after removal. Refer to [BR-47, "BRAKE PAD : Inspection"](#).

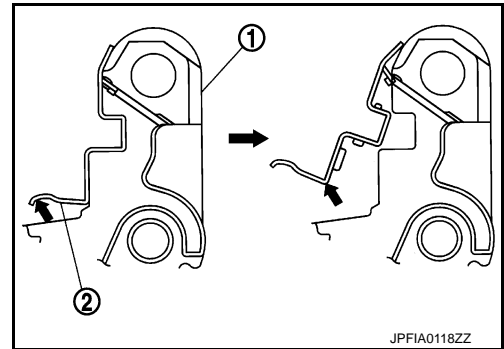

INSTALLATION

WARNING:

Since dust covering the rear brake has an affect on human body, the dust must be removed with a dust collector. Never splatter the dust with an air blow gun.

CAUTION:

- Never depress the brake pedal while removing the brake pads or the cylinder body because the piston may pop out.
- If the brake fluid or grease adheres to the disc rotor or the cylinder body, quickly wipe it off.

- Install the pad retainers (1) to the torque member (2) if the pad retainers has been removed.

CAUTION:

- Securely assemble the pad retainers so that it will not be lifted up from the torque member.
- Never deform the pad retainers.

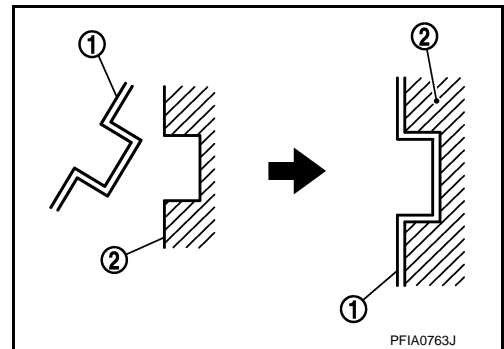

- Apply MOLYKOTE® AS880N or silicone-based grease to the mating faces (A) between the brake pads and the shims, and install the shims and shim covers to the brake pads.

CAUTION:

Always replace the shim together with the shim cover when replacing the brake pad.

Molykote is a registered trademark of Dow Corning Corporation.

- Apply MOLYKOTE® 7439 or equivalent to the mating faces (B) between the brake pads and the pad retainers.

Molykote is a registered trademark of Dow Corning Corporation.

- Install the brake pads to the torque member.

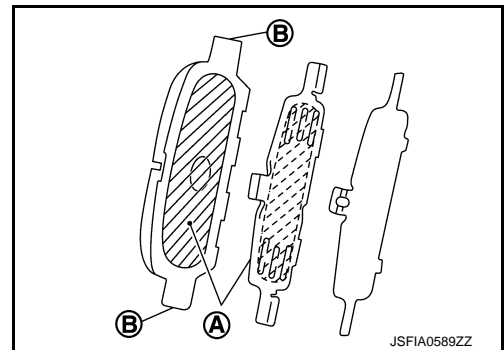

REAR DISC BRAKE

< REMOVAL AND INSTALLATION >

5. Apply MOLYKOTE® AS880N or silicone-based grease to the pawls part (A) of cylinder body, and install cylinder body to the torque member.

CAUTION:

- Never damage the piston boot.
- When replacing brake pad with new one, check a brake fluid level in the reservoir tank because brake fluid returns to master cylinder reservoir tank when pressing piston in.

NOTE:

Use a disc brake piston tool to easily press piston.
Molykote is a registered trademark of Dow Corning Corporation.

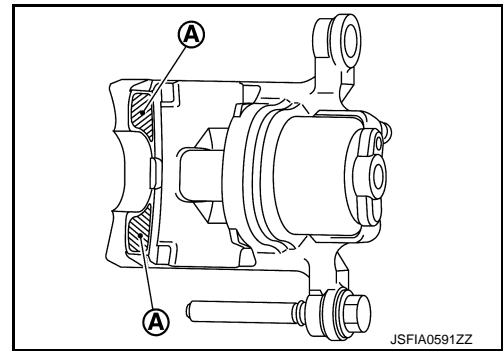

6. Apply rubber grease to sliding pin bolt (upper side), and install the sliding pin bolt (upper side) and tighten it to the specified torque.
7. Depress the brake pedal several times to check that no drag feel is present for the rear disc brake. Refer to [BR-47. "BRAKE PAD : Inspection"](#).
8. Install tires with power tool. Refer to [WT-45. "Removal and Installation"](#).

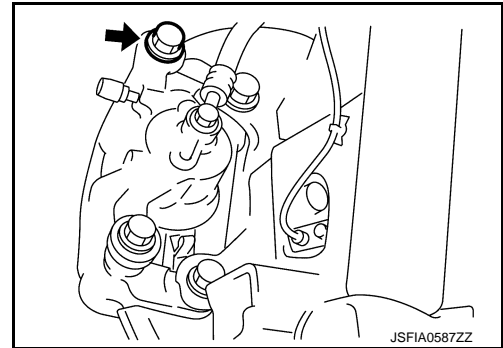

BRAKE PAD : Inspection

INFOID:000000011326145

INSPECTION AFTER REMOVAL

- Replace the shims and the shim covers if rust is excessively attached.
- Eliminate rust on the pad retainers and the torque member. Replace them if rust is excessively attached.

INSPECTION AFTER INSTALLATION

- Check a drag of rear disc brake. If any drag is found, follow the procedure described below.
 1. Remove brake pads. Refer to [BR-45. "BRAKE PAD : Removal and Installation"](#).
 2. Press the pistons. Refer to [BR-45. "BRAKE PAD : Removal and Installation"](#).
 3. Install brake pads. Refer to [BR-45. "BRAKE PAD : Removal and Installation"](#).
 4. Securely depress the brake pedal several times.
 5. Check a drag of rear disc brake again. If any drag is found, disassemble the cylinder body and replace if necessary. Refer to [BR-50. "BRAKE CALIPER ASSEMBLY : Disassembly and Assembly"](#)
- Burnish contact surfaces brake pads and disc rotor after refinishing or replacing brake pads, or if a soft pedal occurs at very low mileage. Refer to [BR-18. "BRAKE PAD : Inspection and Adjustment"](#).

BRAKE CALIPER ASSEMBLY

BRAKE CALIPER ASSEMBLY : Exploded View

INFOID:000000011326146

REMOVAL

REAR DISC BRAKE

< REMOVAL AND INSTALLATION >

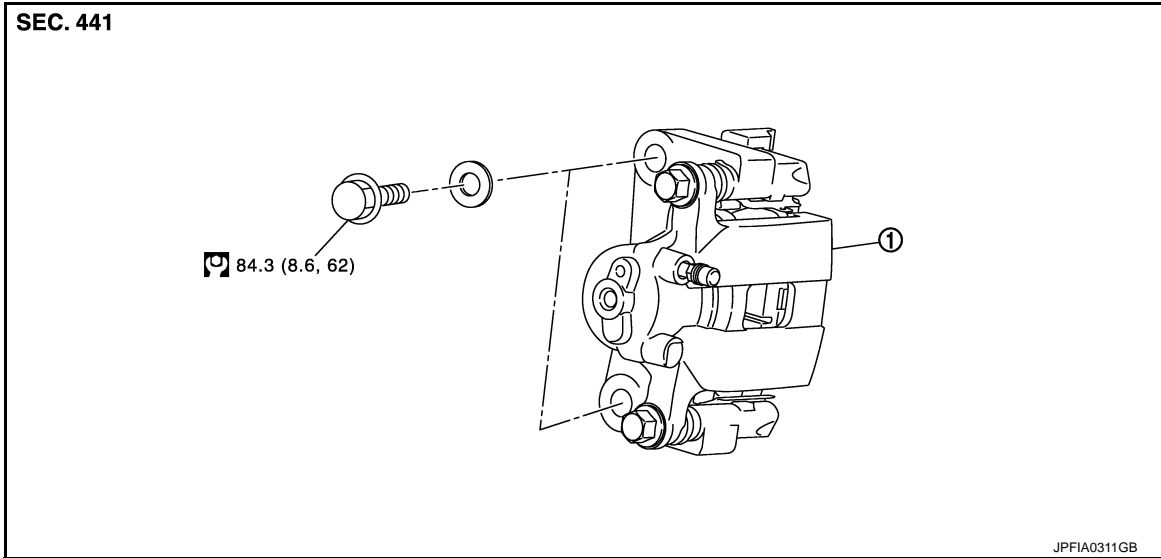

1. Brake caliper assembly

: N-m (kg-m, ft-lb)

DISASSEMBLY

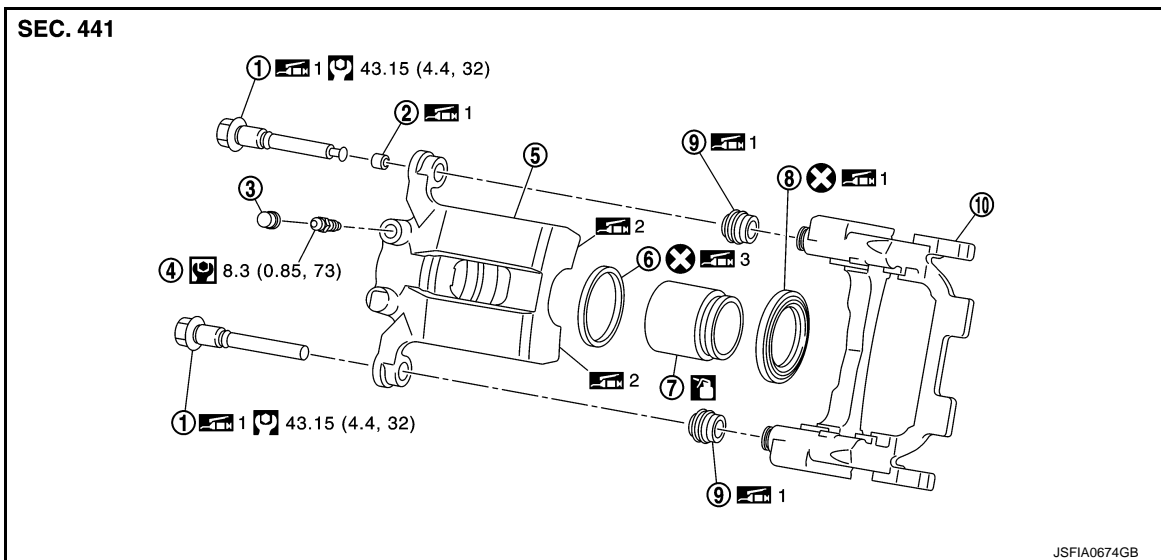

- | | | |
|---------------------|------------------|---------------------|
| 1. Sliding pin bolt | 2. Bushing | 3. Cap |
| 4. Bleeder valve | 5. Cylinder body | 6. Piston seal |
| 7. Piston | 8. Piston boot | 9. Sliding pin boot |
| 10. Torque member | | |

1: Apply rubber grease.

2: Apply MOLYKOTE® AS880N or silicone-based grease.

3: Apply polyglycol ether based lubricant.

: Apply brake fluid.

: N-m (kg-m, ft-lb)

: N-m (kg-m, in-lb)

: Always replace after every disassembly.

REAR DISC BRAKE

< REMOVAL AND INSTALLATION >

Molykote is a registered trademark of Dow Corning Corporation.

BRAKE CALIPER ASSEMBLY : Removal and Installation

INFOID:000000011326147

REMOVAL

WARNING:

Since dust covering the rear brake has an affect on human body, the dust must be removed with a dust collector. Never splatter the dust with an air blow gun.

CAUTION:

- Never spill or splash brake fluid on painted surfaces. Brake fluid may seriously damage paint. Wipe it out immediately and wash with water if it gets on a protect surface. For brake component parts, never wash them with water.
- Never depress the brake pedal while removing the brake hose. If this is not complied with, brake fluid may splash.
- Never drop removed parts.
- If the brake fluid or grease adheres to the disc rotor, quickly wipe it off.

1. Remove tires with power tool.
2. Fix the disc rotor using wheel nuts.
3. Drain brake fluid. Refer to [BR-12. "Draining"](#).
4. Separate brake hose from caliper assembly. Refer to [BR-26. "REAR : Removal and Installation"](#).
5. Remove torque member mounting bolts, and remove brake caliper assembly.

CAUTION:

Never drop brake pad and caliper assembly.

6. When removing disc rotor. Refer to [RAX-7. "Removal and Installation"](#).

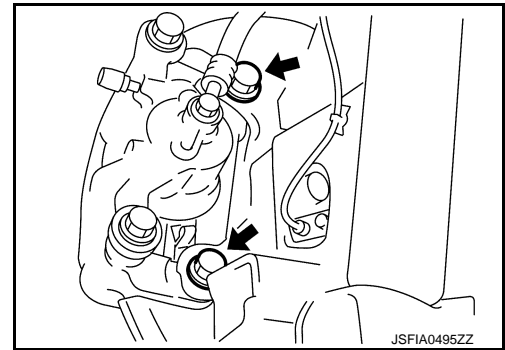

INSTALLATION

WARNING:

Since dust covering the rear brake has an affect on human body, the dust must be removed with a dust collector. Never splatter the dust with an air blow gun.

CAUTION:

- Never spill or splash brake fluid on painted surfaces. Brake fluid may seriously damage paint. Wipe it out immediately and wash with water if it gets on a protect surface. For brake component parts, never wash them with water.
- Never depress the brake pedal while removing the brake hose. If this is not complied with, brake fluid may splash.
- Never drop removed parts.
- If the brake fluid or grease adheres to the disc rotor, quickly wipe it off.

1. Install disc rotor. Refer to [RAX-7. "Removal and Installation"](#).
2. Install the brake caliper assembly to the axle housing and tighten the torque member mounting bolts to the specified torque.

CAUTION:

Never spill or splash any grease and moisture on the brake caliper assembly mounting face, threads, mounting bolts and washers. Wipe out any grease and moisture.

3. Install brake hose. Refer to [BR-26. "REAR : Removal and Installation"](#).
4. Perform the air bleeding. Refer to [BR-13. "Bleeding Brake System"](#).
5. Check a drag of rear disc brake. If any drag is found, refer to [BR-52. "BRAKE CALIPER ASSEMBLY : Inspection"](#).

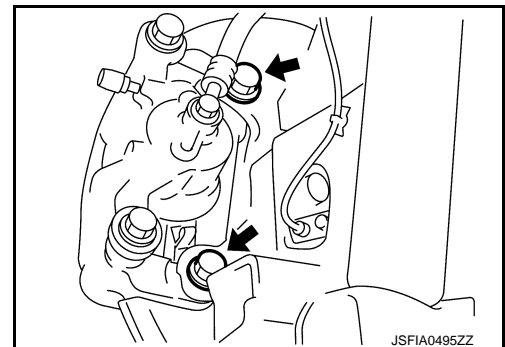

REAR DISC BRAKE

< REMOVAL AND INSTALLATION >

6. Install tires with power tool. Refer to [WT-45, "Removal and Installation"](#).
7. Perform inspection after installation. Refer to [BR-52, "BRAKE CALIPER ASSEMBLY : Inspection"](#).

BRAKE CALIPER ASSEMBLY : Disassembly and Assembly

INFOID:000000011326148

DISASSEMBLY

CAUTION:

Never drop the parts.

NOTE:

Never remove the torque member, brake pad and pad retainers when disassembling and assembling the cylinder body.

1. Remove the sliding pin bolt, and remove the cylinder body from the torque member. Refer to [BR-45, "BRAKE PAD : Removal and Installation"](#).

CAUTION:

Fix the brake pad at suitable tape so that the brake pad will not drop.

2. Remove sliding pin boots from torque member.
3. Remove bushing (1) from sliding pin bolt (2).

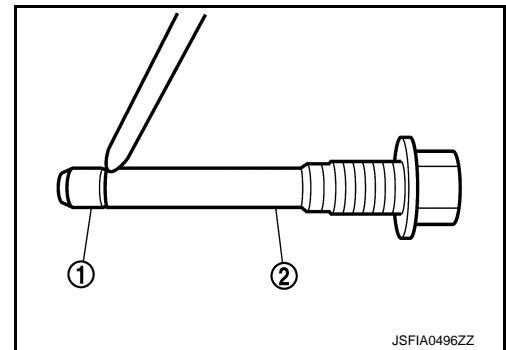

4. Place a wooden block as shown in the figure, and blow air from union bolt mounting hole to remove pistons and piston boots.

CAUTION:

Never get fingers caught in the pistons.

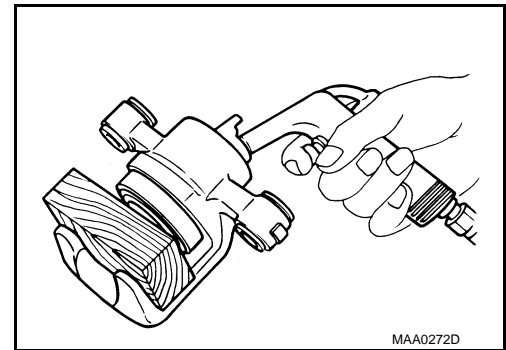

5. Remove piston seal from cylinder body using seal pick tool.

CAUTION:

Be careful not to damage a cylinder inner wall.

6. Remove bleeder valve and cap.
7. Perform inspection after disassembly. Refer to [BR-52, "BRAKE CALIPER ASSEMBLY : Inspection"](#).

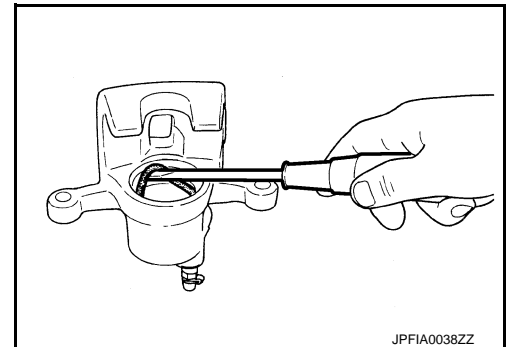

ASSEMBLY

CAUTION:

Never drop the parts.

1. Install bleeder valve and cap.

REAR DISC BRAKE

< REMOVAL AND INSTALLATION >

2. Apply polyglycol ether based lubricant to piston seals (1), and install them to cylinder body.

CAUTION:

Never reuse piston seals.

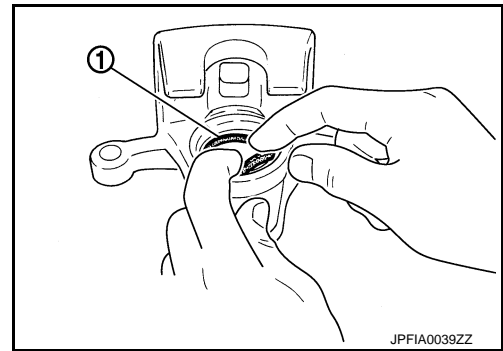

3. Apply rubber grease to piston boots (1). Cover the piston (2) end with piston boot, and then install cylinder side lip on piston boot securely into a groove on cylinder body.

CAUTION:

Never reuse piston boots.

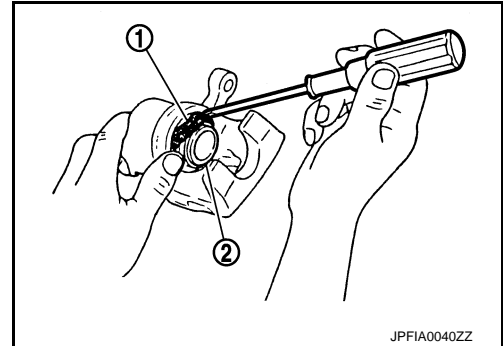

4. Apply new brake fluid to pistons (1). Push piston into cylinder body by hand and push piston boot (2) piston-side lip into the piston groove.

CAUTION:

Press the pistons evenly and vary the pressing point to prevent cylinder inner wall from being rubbed.

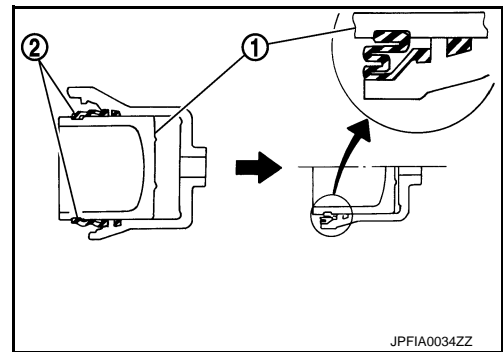

5. Apply rubber grease to mating faces (A) between sliding pin bolt (1) and bushing (2), and install bushing to sliding pin.

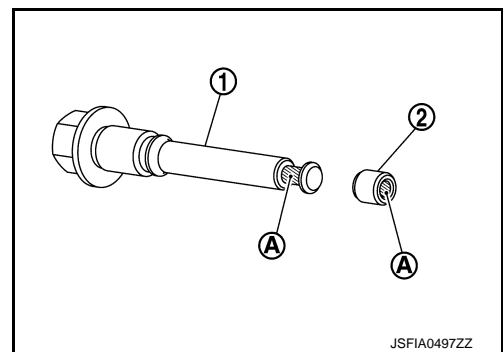

A
B
C
D
E
BR
G
H
I
J
K
L
M
N
O
P

REAR DISC BRAKE

< REMOVAL AND INSTALLATION >

6. Apply rubber grease to mating faces (A) between sliding pin bolt (1) and sliding pin boot (2), and install sliding pin and sliding pin boot to sliding torque member.

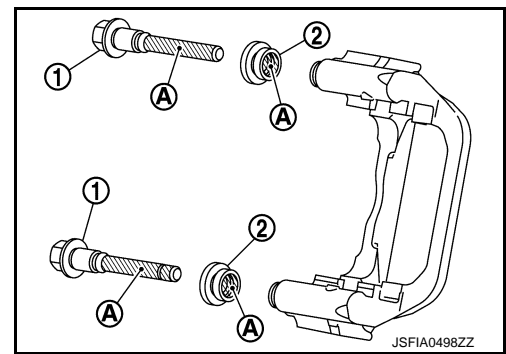

7. Apply MOLYKOTE® AS880N or silicone-based grease to the pawls part (A) of cylinder body. Molykote is a registered trademark of Dow Corning Corporation.
8. Install the cylinder body to tighten sliding pin bolts to the specified torque. Refer to [BR-45. "BRAKE PAD : Exploded View"](#).

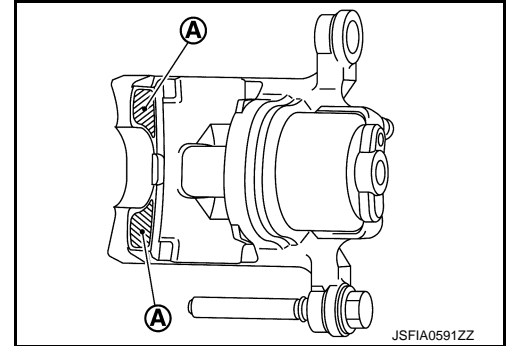

BRAKE CALIPER ASSEMBLY : Inspection

INFOID:000000011326149

INSPECTION AFTER DISASSEMBLY

Check the following items and replace if necessary.

Cylinder Body

Check the inner wall of the cylinder for rust, wear, cracks or damage.

CAUTION:

Always clean with new brake fluid. Never clean with mineral oil such as gasoline and light oil.

Torque Member

Check the torque member for rust, wear, cracks or damage.

Pistons

Check the surface of the piston for rust, wear, cracks or damage.

CAUTION:

A piston sliding surface is plated. Never polish with sandpaper.

Sliding Pin Bolt, Sliding Pin Boot and Bushing

Check the sliding pin bolts, sliding boots and bushing for rust, wear, cracks or damage.

INSPECTION AFTER INSTALLATION

- Check a drag of rear disc brake. If any drag is found, follow the procedure described below.
 1. Remove brake pads. Refer to [BR-45. "BRAKE PAD : Removal and Installation"](#).
 2. Press the pistons. Refer to [BR-45. "BRAKE PAD : Removal and Installation"](#).
 3. Install brake pads. Refer to [BR-45. "BRAKE PAD : Removal and Installation"](#).
 4. Securely depress the brake pedal several times.
 5. Check a drag of rear disc brake again. If any drag is found, disassemble the cylinder body and replace if necessary. Refer to [BR-50. "BRAKE CALIPER ASSEMBLY : Disassembly and Assembly"](#).
- Burnish contact surface between disc rotor and brake pads after refinishing or replacing disc rotor or brake pad, or if a soft pedal occurs at very low mileage. Refer to [BR-18. "DISC ROTOR : Inspection and Adjustment"](#).

SERVICE DATA AND SPECIFICATIONS (SDS)

< SERVICE DATA AND SPECIFICATIONS (SDS)

SERVICE DATA AND SPECIFICATIONS (SDS)

SERVICE DATA AND SPECIFICATIONS (SDS)

General Specifications

INFOID:0000000011326150

Unit: mm (in)

Front brake	Cylinder bore diameter	47.62 (1.8748) × 2
	Pad length × width × thickness	132.0 × 44.5 × 10.0 (5.20 × 1.752 × 0.394)
	Rotor outer diameter × thickness	290 × 28.0 (11.42 × 1.102)
Rear brake	Cylinder bore diameter	42.86 (1.6874)
	Pad length × width × thickness	83.0 × 33.0 × 8.5 (3.268 × 1.299 × 0.335)
	Rotor outer diameter × thickness	308 × 16.0 (12.13 × 0.630)
Master cylinder	Cylinder bore diameter	25.4 (1.0)
Control valve	Valve type	Electric brake force distribution
Brake booster	Diaphragm diameter	Primary: 228.5 (9.00)
		Secondary: 203 (7.99)
Recommended brake fluid		Refer to MA-10, "Fluids and Lubricants" .

Brake Pedal

INFOID:0000000011326151

Unit: mm (in)

Item	Standard
Brake pedal height	195.6 – 205.6 (7.70 – 8.09)
Depressed brake pedal height [Depressing 490 N (50 kg, 110 lb) while turning the engine ON]	105.0 (4.13) or more
Clearance between stop lamp switch and brake switch threaded end and the stopper rubber	0.2 – 1.96 (0.008 – 0.0772)
Brake pedal play	3 – 11 (0.12 – 0.43)

Brake Booster

INFOID:0000000011326152

Unit: mm (in)

Item	Standard
Input rod length	127.0 – 128.0 (5.00 – 5.04)

Front Disc Brake

INFOID:0000000011326153

Unit: mm (in)

Item	Limit	
Brake pad	Wear thickness	2.0 (0.079)
	Wear thickness	26.0 (1.024)
Disc rotor	Thickness variation (measured at 8 positions)*	0.015 (0.0006)
	Runout (with it attached to the vehicle)	0.040 (0.0016)

*To check if rotor imbalance, rotor runout or rotor deformation is occurred.

Rear Disc Brake

INFOID:0000000011326154

Unit: mm (in)

Item	Limit	
Brake pad	Wear thickness	2.0 (0.079)

SERVICE DATA AND SPECIFICATIONS (SDS)

< SERVICE DATA AND SPECIFICATIONS (SDS)

Item		Limit
Disc rotor	Wear thickness	14.0 (0.551)
	Thickness variation (measured at 8 positions)*	0.015 (0.0006)
	Runout (with it attached to the vehicle)	0.050 (0.0020)

*To check if rotor imbalance, rotor runout or rotor deformation is occurred.